



Scanned from the collections of
The Library of Congress



Packard Campus
for Audio Visual Conservation
www.loc.gov/avconservation

Motion Picture and Television Reading Room
www.loc.gov/rr/mopic

Recorded Sound Reference Center
www.loc.gov/rr/record



The TALKING MACHINE WORLD

AND
NOVELTY
NEWS

Published Each Month by Edward Lyman Bill at 373 Fourth Avenue, New York, January 15, 1914



The best-known trade mark in the world

"The Victor talking machine's design, 'His Master's Voice,' has become a household word, and the quaint little fox terrier at attention before the horn is familiar to more Americans than any of the world's great masterpieces"—*Collier's Weekly*.

Leading Jobbers of Talking Machines in America

Landay
BROS. INC.

VICTOR JOBBERS Exclusively
What you want always in stock
400 Fifth Avenue
27 W. 34th Street
563 Fifth Avenue
153 W. 42d Street } **New York**

1856 **WURLITZER** 1914

VICTOR
DISTRIBUTERS

VICTORS EXCLUSIVELY

We make a specialty of getting the order out on time—every time.

The Rudolph Wurlitzer Co.
CINCINNATI and CHICAGO

Two points of supply; order from the nearer.

CHASE & WEST DES MOINES IOWA

Machines **Victor** Everything
Records in stock all
Cabinets the time.

WHOLESALE TO IOWA TRADE

Send us your name and address and we will mail you postpaid complete illustrated catalogues, giving detailed information concerning all Victor products. Showing the various styles of Victor Machines, list of all Victor Records, the entire line of Victor Cabinets, Repair Parts and all Accessories. Dealers, let us help you build a Victor business.

PERRY B. WHITSIT L. M. WELLER

PERRY B. WHITSIT CO.,

213 South High Street, Columbus, Ohio.

Edison Phonographs and Records **JOBBERS** Victor Talking Machines and Records

OLIVER DITSON COMPANY
BOSTON

Largest VICTOR Talking Machine Distributors East of Chicago.

Creators of "The Fastest Victor Service." Let us tell you more about our service.

W. J. DYER & BRO.

Saint Paul, Minn.

VICTOR & EDISON
Distributors

Quick Service for all points in the Northwest. Machines, Records, Supplies.

VICTOR DEALERS
TRY US FIRST

We carry the Largest Stock of VICTROLAS, RECORDS and CABINETS of any Distributor in the South.

THE CORLEY COMPANY, Richmond, Va.



Where Dealers May Secure

COLUMBIA

Product

Ready, Full Stocks, and Prompt Deliveries from Convenient Shipping Centers all over the United States.

Distributors

- Atlanta, Ga., Columbia Graphophone Co., 182 Peachtree St.
- Baltimore, Md., Columbia Graphophone Co., 805-807 North Howard St.
- Birmingham, Ala., Columbia Graphophone Co., 1818 Third Ave.
- Boston, Mass., Columbia Graphophone Co., 174 Tremont St.
- Buffalo, N. Y., Columbia Graphophone Co., 622 Main St.
- Chicago, Ill., Columbia Graphophone Co., 14 N. Michigan Ave.
- Cincinnati, O., Columbia Graphophone Co., 117-119 W. Fourth Ave.
- Cleveland, O., Columbia Graphophone Co., 918 Euclid Ave.
- Dallas, Tex., Southwestern Talking Machine Co., 1403 Main St.
- Denver, Colo., Columbia Stores Co., 505-507 Sixteenth St.
- Detroit, Mich., Columbia Graphophone Co., 114 Broadway.
- El Paso, Tex., Southwestern Talking Machine Co., Stanton and Texas Sts.
- Hartford, Conn., Columbia Graphophone Co., 719 Main St.
- Indianapolis, Ind., Columbia Graphophone Co., 27 N. Pennsylvania St.
- Kansas City, Mo., Columbia Graphophone Co., 1112 Grand Ave.
- Lincoln, Nebr., The Grafonola Company, 1036 O St.
- Livingston, Mont., Scheuber Drug Co.
- Los Angeles, Cal., Columbia Graphophone Co., 420-422 S. Broadway.
- Louisville, Ky., Columbia Graphophone Co., 425 South Fourth St.
- Milwaukee, Wis., Albert G. Kunde, 516 Grand Ave.
- Minneapolis, Minn., Columbia Graphophone Co., 424 Nicollet Ave.
- New Haven, Conn., Columbia Graphophone Co., 25 Church St.
- New Orleans, La., Columbia Graphophone Co., 933 Canal St.
- New York City, Columbia Graphophone Co., 89 Chambers St.; Columbia Graphophone Co., 35-37 W. 23d St.; Columbia Graphophone Co., 39 W. 125th St.
- Philadelphia, Pa., Pennsylvania Talking Mach. Co., 1109 Chestnut St.
- Pittsburgh, Pa., Columbia Graphophone Co., 101 Federal St.
- Portland, Me., Columbia Graphophone Co., 550 Congress St.
- Portland, Ore., Columbia Graphophone Co., 371 Washington St.; Eilers Music House.
- Providence, R. I., Columbia Graphophone Co., 119 Westminster St.
- Rochester, N. Y., The Grafonola Company, 38 South Ave.
- Sacramento, Cal., Kirk, Geary & Co.
- Salt Lake City, Utah, Daynes-Beebe Music Co., 45 Main St.
- San Francisco, Cal., Columbia Graphophone Co., 334 Sutter St.
- Seattle, Wash., Columbia Graphophone Co., 1311 First Ave.; Eilers Music House, 3d and University Sts.
- Spokane, Wash., Columbia Graphophone Co., 818 Sprague Ave.
- Springfield, Mass., Columbia Graphophone Co., 174 Worthington St.
- St. Louis, Mo., Columbia Graphophone Co., 1008 Olive St.
- St. Paul, Minn., Columbia Graphophone Co., 20 E. Seventh St.
- Tampa, Fla., Tampa Hardware Co.
- Terre Haute, Ind., 640 Wabash Ave.
- Toledo, O., Columbia Graphophone Co., 229 Superior St.
- Washington, D. C., Columbia Graphophone Co., 1210 G St., N. W.

DEALERS WANTED--Exclusive selling rights given where we are not actively represented.

Write for particulars to the Columbia Graphophone Co., Wholesale Department, Woolworth Building, New York.

Headquarters for Canada:

Columbia Graphophone Co., 363-5-7 Sorauren Ave. Toronto, Ont.

Every Jobber in this country should be represented in this department. The cost is slight and the advantage is great. Be sure and have your card in the February List.

SANGER BROTHERS
Dallas, Texas

VICTOR
Distributors

"We ship the same day."

W. D. ANDREWS

Syracuse - - Buffalo

All orders are acknowledged the same day received by shipping the goods. Make us prove it. All foreign records in our stock.

Victor - - Edison

Southern Victor Dealers

Largest Stock VICTROLAS and RECORDS

Prompt shipment and low freight rates

Walter D. Moses & Co.

Oldest Music House in Virginia or North Carolina
RICHMOND, VA.

Edison Phonograph Distributors
for the SOUTHWEST

All Foreign Records in Stock

Houston Phonograph Co., HOUSTON, TEXAS

NEW ENGLAND
JOBBER HEADQUARTERS
EDISON AND VICTOR

Machines, Records and Supplies

THE EASTERN TALKING MACHINE CO.
177 Tremont Street BOSTON, MASS.

PACIFIC COAST DISTRIBUTORS OF

Victor Talking Machines and RECORDS

STEINWAY PIANOS--LYON & HEALY
"OWN MAKE" BAND INSTRUMENTS

Sherman, Clay & Co. San Francisco Oakland Portland Los Angeles

Talking Machine Dealers

Who are desirous of adding new features to their line should consult

The Music Trade Review

This is the oldest music trade publication in this country, having appeared without interruption since July, 1879.

It is published every Saturday, and contains a thorough and exhaustive résumé of all departments of the music trade industry.

Its editions vary from 60 to 150 pages. It is conceded to be the most influential paper representing the music trade, and if you are interested in the topics with which it deals, do not fail to receive this paper regularly.

Ask for a sample copy.

Regular subscription price is \$2 per year.

EDWARD LYMAN BILL, Editor and Proprietor

373 FOURTH AVENUE, NEW YORK

The Talking Machine World

Vol. 10. No. 1.

New York, January 15, 1914.

Price Ten Cents

FATTENING THE MAILING LIST.

How Dealers Can Double and Treble Record Sales of Their Purchasers' Lists.

The dealer was going over his mailing list preparatory to sending out a monthly supplement—256, 257, 258—that was all. There was always the same number, every time, 258 homes with graphophones—the possibility for 258 sales—no more. And all of them would not buy!

The dealer's eye stopped at a name, Joseph Smith. The dealer looked at it long and longingly. Joseph was a rich man with a large family. Each month he had received his Columbia supplement and immediately purchased four or five records. The dealer suddenly remembered that Joseph Smith had a son. Joseph Smith, Jr., was a strapping boy of thirteen, a very active member of the Boy Scout Patrol in the town. Mr. Smith, Sr., was sixty-five years old, and therefore beyond the Boy Scout limit, but (and this was the dealers thought), if Smith, Jr., ever heard that Ernest Thompson Seton record, Smith, Sr., would have to dig down in his pockets for the "where-with-all."

The dealer took one of his cards, wrote on the back, "Your son will want Record A-1331, Scout Patrol Calls; send him around to hear it," and slipped the card in the supplement for J. S.

One thing often begets another, and no sooner had that dealer glanced at the next name on his list than he remembered that Mrs. Blake had a G. A. R. grandfather sitting at home. Out came another card and the notation, "Captain Blake would enjoy our record A-360. Let us send you our collection of old-time melodies and war songs."

The dealer's thinking, having a good start, soon swelled the mailing list up to three times its previous sales possibilities.

He canvassed the family situation with every name on his list. A house with a graphophone was not only a house with a graphophone—it was a house with a baby, or a house with a boy and two babies, or a house containing a grandmother, or a school-girl. Some special suggestions went out with all sales. Lullabies were suggested for the baby, slam-bang band records for the school-boy, piano records for sister's musical studies, war-time selections for grandfather, old-time melodies for grandmother, and always the choice of the "favorite selection" for all.

"Did the sales of this dealer increase?" asks the Columbia Record. Try it yourself.

DID A LARGE HOLIDAY BUSINESS.

The talking machine department recently opened by the F. G. Smith Piano Co. at 1217 F street, Washington, D. C., is proving a successful venture. It is located on the first floor of the warerooms, and the Victor and Columbia machines and records are represented. W. P. Van Wickle, vice-president of the company, reports having transacted a very large business during the holiday season.

R. L. HOLLINSHEAD TAKES CHARGE.

(Special to The Talking Machine World.)

BUFFALO, N. Y., January 9.—Rubert L. Hollinshead has been appointed manager of the Victrola department of J. N. Adam & Co., the prominent department store in this city. Mr. Hollinshead succeeds H. V. Kautzmann, who has accepted a position with Mason & Risch, Toronto.

ENTHUSIASTIC OVER TRADE OUTLOOK

H. B. McNulty, general sales manager of the Union Specialty & Plating Co., Cleveland, O., manufacturer of the Union phonograph specialties, was a visitor last week to the offices of The Talking Machine World. Mr. McNulty spoke optimistically of the business outlook, being enthusiastic over the rapid strides in popularity that the company's products are making in the East.

LOCAL COMMERCE BUREAU IS LIKED.

Business Men Find It Very Valuable in Getting Information on Foreign Markets.

Much appreciation has been expressed in New York by prominent business men of the action of the Department of Commerce in establishing a branch of the Bureau of Foreign and Domestic Commerce at the local Custom House. This bureau has for some time rendered a great deal of valuable assistance to manufacturers and exporters who have needed information on various foreign markets, and the establishment of the local branch has made this service more rapid, and therefore more valuable.

A great deal of interest has been shown in the manuscript Consular reports shown at the local office, according to George W. Doonan, who is in charge.

"Many manufacturers and merchants have availed themselves of the opportunity to inspect the tenders for bids, plans and specifications which have been sent to this office," he said to a newspaper man this week. "Previous to the opening of the local office these documents were loaned in the order of application, and sometimes a list of forty or fifty firms would be interested in the same thing. As time is the essence of value of much of this material, it can be readily seen that by the time a document had gone the rounds it might be useless to those who received it last.

"Hundreds of applications are being made for the 'reserved information' connected with the foreign trade opportunities service, and almost numberless inquiries have been made for statistics of exports and imports of various foreign markets. Again, foreign tariff rates are often asked for.

"Other branches will be opened in large cities soon, and these offices, it is thought, can be made of the utmost value by making them the local headquarters for American Consular officers visiting the United States and for the bureau's commercial agents returning to this country on the completion of special investigations, for the purpose of conferring with manufacturers and merchants interested in trade conditions in the Consul's district or in the trade made the subject of the commercial agent's special investigation. Recent visits of these men here have proved the value of the scheme, as both the Government officials and the business men have been benefited by the interchanging of ideas and information."

FIRE CAUSES HEAVY LOSS.

Large Stock of Talking Machines and Records Destroyed in Fire Which Guttled Big Department Store of C. T. Sherer, Worcester, Mass.

(Special to The Talking Machine World.)

WORCESTER, MASS., January 3.—The large department store of C. T. Sherer was almost totally destroyed by fire, causing a loss of \$250,000, on the morning of December 21. On the sixth floor of the establishment was a large stock of talking machines and records, and these were made useless. In the lot of goods were 1,000 disc records, which were either burned or smashed to bits. As the store was having a large holiday trade, the fire came at a most inopportune time, especially as the sale of machines and discs had been particularly heavy and much of the stock destroyed was for immediate delivery.

COMPLETE IMPROVEMENTS.

The New York Talking Machine Co., 81 Chambers street, New York, has just completed a number of additional improvements in its sales offices, conducing to the maximum convenience and comfort of its clients. All of these new changes permit of the handling of the company's dealers' requirements at top-notch efficiency.

MR. EDISON SEES MISS KELLER.

Inventor Thinks He Can Give Her Actual Sound Perceptions—Hats Prove Medium.

A meeting, which had been much desired for many years, was arranged between Helen Keller and Thomas A. Edison at the Edison home in Llewellyn Park recently, just before Miss Keller and her teacher, Mrs. Macy, started west to continue a lecture trip. Miss Keller was much interested in all that Mr. Edison told her of recent experiments and inventions.

"Tell me more about your wonderful inventions," she said over and over again.

Mr. Edison showed deep interest in Miss Keller's keenness and delicacy of touch perception. After testing it in various ways he declared his confidence that he could translate sound waves into electrical vibrations, which would give Helen Keller actual sound perceptions.

One method of conveying the vibrations of the disc to Miss Keller on this occasion was by inserting an ordinary derby hat into the horn of the phonograph with the crown of the hat outward. Putting her fingers on the crown of the hat, the vibrations of the music were conveyed to Miss Keller. A silk hat was tried in place of the derby, and still better results were accomplished. The ragtime pieces seemed to afford Miss Keller the most enjoyment, probably because the vibrations were clearer and stronger; band music, also, was very successfully conveyed to her through her fingers on the crown of the hat. At no time, however, can it be said that Miss Keller "heard" the music. What she did get was the vibrations, and the lively pieces were most enjoyed.

Miss Keller and Mrs. Macy will spend a day with Mr. Edison in his laboratories on their return from the West for the purpose of assisting in experiments to this end.

CASE SETTLED OUT OF COURT.

Action Brought by Burton H. Corbett Against President of Boston Talking Machine Co. Settled Out of Court When Near Hearing.

(Special to The Talking Machine World.)

BOSTON, MASS., January 9.—Burton H. Corbett, of Brookline, formerly of Denver, who was mentioned in The World last month as having left here following the financial difficulties of the Boston Talking Machine Co., of which he was manager, brought suit for \$100,000 against Henry M. Whitney, president of the company. Corbett alleged that he entered into a written contract with Whitney on July 31, 1913, to enter the employ of the talking machine company, of which Whitney was president and a large financial owner. He claimed that he was to act as manager, to have control of the factory in Cambridge, and was to receive \$26,000 a year and a percentage. He broke up his business to come here, he claimed, and worked for a few months for the talking machine company. He says he asked Whitney for money and was refused. He alleged Whitney did not pay him in full for the work he did; that he performed his part of the contract, but Whitney did not perform his, and that he was entitled to damages. Twenty-four hours after the announcement of the suit came a statement that an agreement had been reached between the attorneys representing Messrs. Whitney and Corbett. The case, it appears, had been settled out of court.

HANDSOME WALL HANGER.

In order that its dealers might call the attention of the public to the new record catalog it recently issued, the Victor Talking Machine Co. sent out to its trade last week a handsome wall hanger or window display portraying a page from the new catalog.

EDISON PATENTS NEW RECORDS.

New Invention Provides for Hardened Surface for Ordinary Form of Wax Cylinder Records—Some Details of the Process.

Thomas A. Edison has secured and assigned to the New Jersey Patent Co., of West Orange, N. J., a patent for a new method of making phonograph records so that the surface will be harder and present greater resistance to the wear of the reproducing stylus. This invention is especially designed to make it possible to record on the cylinder at the rate of 200 grooves per inch and still have a record that will resist the increased wear satisfactorily.

As is the case with the ordinary cylinder records, Mr. Edison's new invention provides for a record made of wax or other easily molded material, but with the surface especially hardened. In describing the invention in his patent claims Mr. Edison says in part:

"In the practice of my invention I preferably take a duplicate or original phonograph record, which has been made in any of the usual ways from the usual wax-like composition, and immerse it in a solution of nitrated cotton in any of the ordinary solvents used for this purpose, as, for example, acetate of amyl, which is commonly made use of for providing a liquid solution from which films are made for photographic use. I may, if desired, add a small percentage of camphor to the nitrated cotton, thus making a celluloid collodion solution, but this may be dispensed with.

"I place the record upon a dipping mandrel having adjustable extension ends at each end of the record. It is then immersed in the solution while held vertically; it is then withdrawn and subjected to a gentle breeze from a fan—to slightly affect or harden the surface; it is then immersed a second time and subjected to the air. If the solution is rather thick, two such dips will give a sufficient thickness of film over the record when the latter is dried. Sometimes it is best to make the solution thinner, when three or more dips will be necessary. After the dips, the mandrel is transferred to a machine which rotates it in a horizontal position until nearly free from solvent, when it may be taken off the mandrel and set aside until the whole of the solvent has evaporated, leaving a very hard, tough film on the surface of the record.

"It is a remarkable fact, and entirely unexpected, that although the average depth of the indentations on a record is only half of one thousandth of an inch and the greatest depth one thousandth of an inch, yet, if the thickness of the film of the nitro-cellulose when dry is three thousandths of an inch, a perfect replica of the record underneath is produced on the surface of the cellulose above, even

to the finest detail, and what is more strange is that the depth of the wave is so little affected that the loss in the volume of sound is scarcely noticeable.

"Very deep records can be made and the reproducing balls can be pressed with sufficient force against the cellulose as to cause it to follow the record without injury to it, which would be im-

possible if the ball was forced against the record surface below. Thus, the volume and quality of the sound can be increased, and the sound record can be used indefinitely without noticeable deterioration.

"Other film-producing liquids may be used in place of the nitro-cellulose and its solvents, such as acetyl-cellulose in acetic acid."

PROGRESSIVE NEWBURGH DEALERS

Are John Schoonmaker & Son, Who Have Built Up a Splendid Business with the Columbia Line—Excellent Work Accomplished by Manager F. A. Munger—A Model Department.

(Special to The Talking Machine World.)

NEWBURGH, N. Y., January 9.—The accompanying illustration pictures the talking machine department of John Schoonmaker & Son, of this city. It emphasizes the success a department can achieve when high-grade methods are used to exploit the products handled therein. This company,

grade publicity when coupled with products of merit. Mr. Munger has also staged a number of interesting recitals at frequent intervals, which present the Columbia machines and records to the very best possible advantage.

The department itself is a model of quiet and dignified refinement. The color scheme throughout is white enamel, and booths being finished in an attractive style with furnishings and decorations conducive to the comfort and convenience of the store's patrons. Although the Columbia department closed a remarkably good business during the few months it has been open, the sales staff is

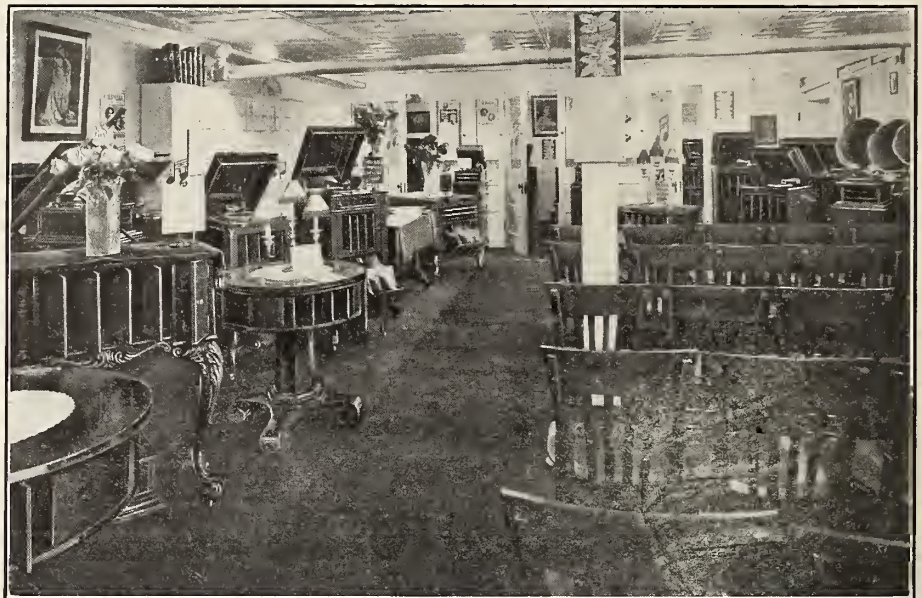

John Schoonmaker's Handsome Warerooms and Recital Hall.

which handles the products of the Columbia Graphophone Co. exclusively, has been in the talking machine business only a few months, but in this short space of time has acquired an extensive high-grade clientele for Columbia machines and records that is growing steadily.

The Columbia department of John Schoonmaker & Son, which is one of the largest department stores in this section of the State, is under the able management of F. A. Munger, who is a firm believer in the drawing powers of consistent high-

preparing energetic plans for a proportionately better year in 1914.

George E. Lang, of Barton, Vt., is remodelling his phonograph parlor and has restocked with the new Edison Amberolas.

Frank J. Butler, a live-wire and progressive Victor dealer at Pontiac, Ill., is giving a series of recitals at his store that are attracting music lovers from many near-by towns.

A Happy and Prosperous New Year to All

1913 is of the past, and 1914 is opening up before us. May the New Year bring to all, Happiness, Good Health and Prosperity

To our dealers, through whose patronage our business in 1913 was by far the largest in the history of our company, we extend our heartiest thanks, and we shall, by the constant and never failing effort to improve our service, endeavor to warrant a continuance of this patronage and attract new trade, that we may familiarize them with EASTERN SERVICE and in turn number them among our regular dealers to whom we extend preferred consideration in the times of shortages of goods, which seem unavoidable at certain seasons of the year.

To the Dealers Not Using Our Service We Say: Get Acquainted

EASTERN TALKING MACHINE COMPANY

177 TREMONT STREET, BOSTON, MASS.

EDISON

FOR NINETEEN YEARS TALKING MACHINES EXCLUSIVELY

VICTOR



Victor-Victrola VI, \$25
Oak

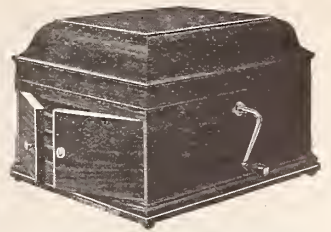

Victor-Victrola IX, \$50
Mahogany or oak

Victor-Victrola

The big opportunity in the music trade.

The Victor-Victrola occupies the most commanding position in the entire musical world. From a purely musical standpoint, the Victor-Victrola is the most wonderful musical achievement of modern times.

And on the business side, the Victor-Victrola has a record of accomplishments which establishes it as the most influential force that ever entered into the music trade.

Around the Victor-Victrola centers the prevailing prosperity of the musical industry—a prosperity reflected in the handsome and luxurious showrooms of to-day; a prosperity that extends right down to the very foundation of the music trade, which it has placed upon a more dignified and more substantial basis.

The Victor-Victrola keeps right on bringing greater opportunities to every dealer, accompanied by profit and prestige greater than ever before.



Victor-Victrola XI, \$100
Mahogany or oak



Victor-Victrola XVI, \$200
Mahogany or oak

Victor Talking Machine Co.,
Camden, N. J., U. S. A.

Berliner Gramophone Co., Montreal, Canadian Distributors
Always use Victor Machines with Victor Records and Victor Needles—
the combination. There is no other way to get the unequalled Victor tone.

Victor Distributors

- | | | |
|---|---|---|
| <p>Albany, N. Y...... Finch & Hahn.
Altoona, Pa...... W. F. Frederick Piano Co.
Atlanta, Ga...... Elyea-Austell Co.
Phillips & Crew Co.
Austin, Tex...... The Talking Machine Co., of
Texas.
Baltimore, Md...... Cohen & Hughes, Inc.
E. F. Droop & Sons Co.
H. K. Eisenbrandt Sons.
Bangor, Me...... Andrews Music House Co.
Birmingham, Ala... Talking Machine Co.
Boston, Mass...... Oliver Ditson Co.
The Eastern Talking Machine
Co.
M. Steinert & Sons Co.
Brooklyn, N. Y..... American Talking Machine Co.
Buffalo, N. Y...... W. D. Andrews.
Neal, Clark & Neal Co.
Burlington, Vt..... American Phonograph Co.
Butte, Mont...... Orton Brothers.
Chicago, Ill...... Lyon & Healy.
The Talking Machine Co.
The Rudolph Wurlitzer Co.
Cincinnati, O...... The Rudolph Wurlitzer Co.
Cleveland, O...... The W. H. Buescher & Sons Co.
The Collister & Sayle Co.
The Eclipse Musical Co.
Columbus, O...... Perry B. Whitsit Co.
Dallas, Tex...... Sanger Bros.
Denver, Colo...... The Hext Music Co.
The Knight-Campbell Music Co.
Des Moines, Ia..... Chase & West Talking Mach. Co.
Mickel Bros. Co.
Detroit, Mich..... Grinnell Bros.</p> | <p>Elmira, N. Y...... Elmira Arms Co.
El Paso, Tex...... W. G. Walz Co.
Galveston, Tex..... Thos. Goggan & Bros.
Honolulu, T. H..... Bergstrom Music Co., Ltd.
Indianapolis, Ind... Stewart Talking Machine Co.
Jacksonville, Fla... Florida Talking Machine Co.
Kansas City, Mo..... J. W. Jenkins Sons Music Co.
Schmelzer Arms Co.
Lincoln, Neb...... Ross P. Curtice Co.
Little Rock, Ark.... O. K. Houck Piano Co.
Los Angeles, Cal.... Sherman, Clay & Co.
Louisville, Ky..... Montenegro-Riehm Music Co.
Memphis, Tenn..... O. K. Houck Piano Co.
Milwaukee, Wis..... Wisconsin Talking Machine Co.
Mobile, Ala...... Wm. H. Reynolds.
Montreal, Can..... Berliner Gramophone Co., Ltd.
Nashville, Tenn..... O. K. Houck Piano Co.
Newark, N. J...... Price Talking Machine Co.
New Haven, Conn... Henry Horton.
New Orleans, La..... Philip Werlein, Ltd.
New York, N. Y..... Blackman Talking Machine Co.
Sol. Bloom, Inc.
Emanuel Blout.
C. Bruno & Son, Inc.
I. Davego, Jr., Inc.
S. B. Davego Co.
Chas. H. Ditson & Co.
Landy Brothers, Inc.
New York Talking Machine Co.
Sitas E. Pearsall Co.
Benj. Switky.</p> | <p>Omaha, Neb...... A. Hospe Co.
Nebraska Cycle Co.
Peoria, Ill...... Putnam-Page Co., Inc.
Philadelphia, Pa... Louis Buehn.
C. J. Heppe & Son.
Penn Phonograph Co., Inc.
The Talking Machine Co.
H. A. Weymann & Son, Inc.
Pittsburgh, Pa..... C. C. Mellor Co., Ltd.
Standard Talking Machine Co.
Portland, Me...... Cressey & Allen.
Portland, Ore..... Sherman, Clay & Co.
Richmond, Va..... The Corley Co., Inc.
W. D. Moses & Co.
Rochester, N. Y..... E. J. Chapman.
The Talking Machine Co.
Salt Lake City, Utah.. Consolidated Music Co.
San Antonio, Tex... Thos. Goggan & Broa.
San Francisco, Cal... Sherman, Clay & Co.
Savannah, Ga..... Phillips & Crew Co.
Seattle, Wash..... Sherman, Clay & Co.
Sloux Falls, S. D... Talking Machine Exchange.
Spokane, Wash..... Sherman, Clay & Co.
St. Louis, Mo...... The Aeolian Company of Mo.
Koerber-Brenner Music Co.
St. Paul, Minn..... W. J. Dyer & Bro.
Koehler & Hinrichs.
Syracuse, N. Y..... W. D. Andrews Co.
Toledo, O...... The Whitney & Currier Co.
Washington, D. C... Robert C. Rogers Co.
E. F. Droop & Sons.</p> |
|---|---|---|

UNIQUE RECORD ALBUMS

CONTAINING SIX PAGES OF INDEX

For Durability, Artistic Design and Finish, our Albums have no equal. They are made in the most substantial manner by skilled workman, and are first-class in every particular. We sell them at very low prices to meet competition.

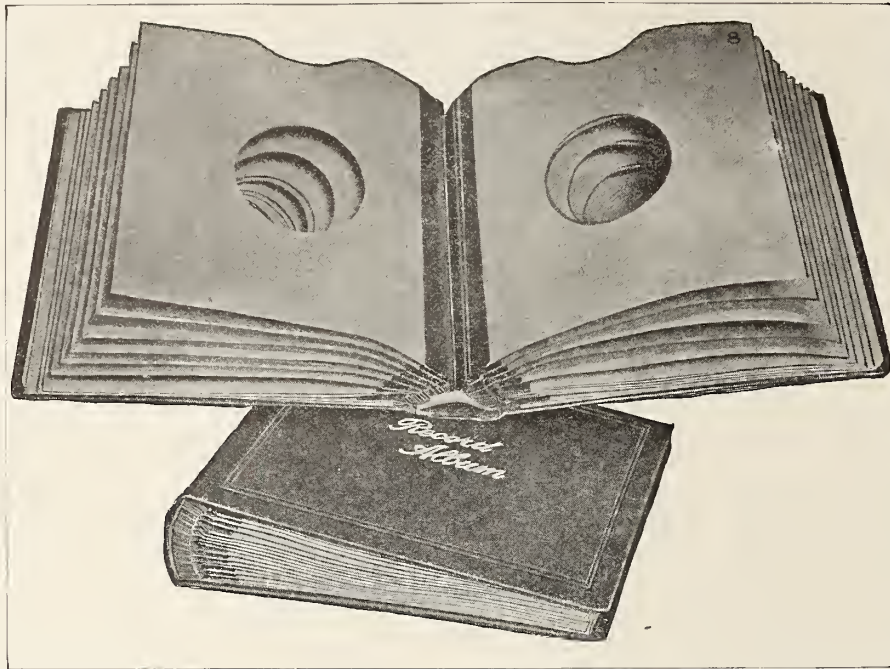

DISC RECORD ALBUMS
ARE WHAT EVERY
Talking Machine Owner
MUST NOW HAVE

With the index they make a complete system for filing away all disc Records, and can be added to, Album by Album, as Records accumulate, like books in a library.

OUR SUPERB ALBUMS ARE BEST FOR VICTOR, COLUMBIA AND ALL OTHER TALKING MACHINES

MADE IN TWO SIZES TO FIT ALL 10 AND 12-INCH DISC RECORDS

These Albums contain 17 pockets made of strong fibre paper, each pocket having a hole in the center, as shown in the picture. These pockets are so made that they show very plainly both the single and double face titles on the Records. The Albums are bound in the finest quality of Brown Silk Finish Cloth, with gilt title on front cover. They are also bound in imitation leather. Write for sample and prices of our Albums, which are superior to all others.

Address NATIONAL PUBLISHING CO., 235 South American St., Philadelphia, Pa

LARGE HOLIDAY BUSINESS DONE IN CINCINNATI.

Leading Talking Machine Houses Say That Business for December Was Not Only Large in Volume But That the Demand Was for the Expensive Styles—Some Talk of the Phonograph Co. Engaging in the Retail Business.

(Special to The Talking Machine World.)

CINCINNATI, O., January 9.—The local branch of the Phonograph Co., of Cleveland, which entered the jobbing field here some time since, closed an immense holiday business under the management of F. O. Peterson. The outlook for a large Edison business in this territory is excellent. There is some talk here of the Phonograph Co. conducting a retail department as well as jobbing business, but Mr. Peterson would not discuss the matter.

John Arnold, the well-known dealer, has been handling Edison goods in this territory for years, being the only representative in the business district. Arnold disposed of his entire stock during the holiday rush and had numerous demands for the higher priced Edison instruments. There is no question but what the Edison instrument has made quite an impression in Cincinnati.

Manager Dittrich, of the Victor talking machine department of the Rudolph Wurlitzer Co., summed up the situation of the past month as follows:

"The month of December exceeded our expectations. The amount of business done was limited only by the amount of machines available with which to fill orders. We are very well satisfied, even though we could have increased the volume of sales very materially had we been able to secure sufficient stock to fill orders. The immense sale of Victrolas and other Victor styles has stimulated record business enormously, and provisions will immediately be made to take care of this increase."

Throughout the month of December and up into January business at the local Columbia store was characterized by strenuous hustle and bustle throughout the day and far into the night.

"Business during the holidays," said Manager Whelen, "was unusual, and we closed a larger December business than any previous holiday season in the history of the Cincinnati store, both in records and machines. The stock was practically cleaned out and, had we been able to secure all the stock necessary to supply the tremendous demand, and room to accommodate all the customers, results would have been far in advance of what they were. The new types of Columbia models stimulated this wonderful demand, and the new Grafo-nola 'Leader' lived up to its name. This little \$75 model is certainly a winner, and if we had been able to get in sufficient of this type we could have tripled our sales even in this one type."

"Business was good throughout the wholesale territory, and during the month we enjoyed the visits of many of our large dealers, who came in personally to select their holiday stock. The year as a whole has been a very gratifying one, and we are now ready to pitch in with renewed vigor to make last year's figures loom up small in the distance when the next New Year rolls around."

"F. A. Norris, who has for years been associated with the Adder Machine Co., has just joined the Dictaphone local forces, and in the short time that he has been associated with the Dictaphone has placed some very nice installations."

Advertising Manager Page, of the Aeolian Co., attributes much of the after-Christmas rush, which has been a feature of the holiday week, to money presents given many people who desire to invest it in a substantial manner, which happens to be a talking machine. In speaking of the business at Aeolian Hall he said:

"December business at Aeolian Hall surpassed

all expectations, although much was expected, the installation of new Victrola booths more than doubling Aeolian facilities, being evidence that a large increase was looked for.

"Business was simply enormous, all styles of Victrolas showing the demand. A very large number of Style XVI were disposed of, including many in special finishes."

"The record business was very much in the nature of a landslide. It proved a very difficult matter to get enough dance records to meet the demand."

"The Aeolian Victor force is in splendid shape and includes a number of new faces. The organization has simply had to be increased half a dozen times in the past few months to meet the requirements of the trade."

The Otto Grau Piano Co. is much elated over the success of its Victrola department, which was instituted during the past year. Its stock was cleaned out by the holiday rush.

The Lyric Piano Co., with its larger and better facilities for handling Victor business, did very well during the Christmas season, as did the Milner Musical Co.

KNOWLEDGE OF RECORDS PAYS.

(Special to The Talking Machine World.)

DAVENPORT, IA., January 8.—The John Hoyt Piano Co., of this city, which maintains an attractive Victor department, recently had placed before it an excellent example of the value to be derived from their Victor salesmen carefully studying the Victor catalog.

One of their salesmen, Mr. Pickens, recently closed a sale of a Victrola XVI to a prominent music lover of this city, who requested him to select a list of records, which were to be sent out on approval. Mr. Pickens selected the records carefully, the total list amounting to \$117. It is a tribute to his judgment and knowledge of the Victor record library that not one of these records was returned by the purchaser.

DETROIT TRADE BEAT 1912 RECORD DURING PAST YEAR.

The Gain in Business Reported by the Leading Jobbers and Dealers Runs from 30 Per Cent. to 80 Per Cent. Increase—Greatest Year with the Columbia Co. in Both Machines and Records—Grinnell Bros.' Victor Business Shows Immense Growth—Other News.

(Special to The Talking Machine World.)

DETROIT, MICH., January 8.—The holiday talking machine trade in Detroit lived up to every hope of the most optimistic dealer, and to every indication outlined in this correspondence a month ago. In fact, it went beyond most hopes, for it is still going top speed.

In the regular period, that is, from December 1 the day before Christmas, every dealer communicated with beat his 1912 record, the margins ranging from fifty to more than a hundred per cent. It then, to leave no doubt as to whether business was good, everybody who received a new "talker" for Christmas showed it to a "talkerless friend," who frequently put on his coat and went downtown to gather in one himself. And subsequent to Christmas the demand for records overwhelmed the statistics.

Manager Harry Rupp, of the talking machine department of Grinnell Bros., said: "We beat last year by about 80 per cent." This means much when it is considered that Grinnell Bros. are Victor jobbers, besides having twenty-five Michigan stores of their own, and last December did a holiday business that seemed to be beyond ordinary condition. "The demand was very well distributed all year," continued Mr. Rupp. "The high-priced machines still maintained their good lead, though." Tax Strasburg was as busy as Mr. Rupp. Though, like Mr. Rupp, he has a big force of salesmen, he was out in the floor in person, selling machines. Mr. Strasburg had the advantage of double the space and double the stock he had last year, therefore he did more than double the business. His stock consists almost entirely of high-priced machines.

It was our greatest December and our greatest year," said Manager K. N. Johns, of the Detroit branch of the Columbia Co. "While we were not able to get all the machines we needed, we were

in far better shape than last year, or in 1911. Last year we lost a great deal of business through being unable to fill orders. This year we had to turn down but little. The Saturday preceding Christmas our store was fairly mobbed all day, but we kept pulling the machines out of the stock room, and sent everybody away satisfied. We got them all delivered in time, too.

"A lucky feature of the business was that the demand was more diversified than in the past. That helped in handling the trade. Last year the calls were largely for one style of machine, the \$50 one. This year they wanted everything on the list, from the \$25 machines to the \$200 ones. So we were in fairly good condition all along.

"We sold 50 per cent. more records than in the last holiday season, and the rush is still on. The people of this city have gone dance crazy. The tango, one-step and hesitation are not confined to the public dance hall patrons, as so many people suppose. The best people in Detroit are buying those records in thousands, to dance by in their homes."

The J. L. Hudson store, which four months ago filled all its spare space with Victrolas and Columbias, and hired a wareroom for more of the stock besides, in order to be certain of plenty to meet all demands this winter, achieved its object, but didn't have much remaining on January 1. Even the low-priced ones were cleaned out, though not to Detroiters.

As in the case of the other downtown dealers, trade is still brisk, especially in dance records. Dance records are not the only ones called for, however. Red Seals are in big demand. Apparently few records were sent out with the gift machines of the holidays, and now the recipients are flocking to the stores to spend as much for records as the machines themselves cost. Which, of course, is very pleasing to the merchants.

TALKING MACHINE SUPPLIES MUSIC

At the Annual Christmas Dinner Given the Poor and Homeless of New York by the Bowery Mission—The Victor Was Used.

At the annual Christmas dinner tendered by the Bowery Mission to the poor and homeless of New York City a Victrola XVI played a prominent part, furnishing all the music at this charitable event. The machine and records were furnished by a local Victor dealer, and the music was just as enthusiastically received by the homeless and poor as if it were being played on the operatic or concert stage.

The records furnished by the dealer were comprehensive in their scope, including grand opera, religious, popular and semi-classic. Many of the evening's guests were greatly affected by the music, which was the subject of the heartiest praise.

TALKING MACHINE DEALER FAILS.

John J. Rooney, a dealer in talking machines and photo supplies at 1983 Broadway, New York, filed a petition in bankruptcy, with liabilities of \$5,863 and assets \$4,065, consisting of stock, \$36; cash in bank, \$620, and return on insurance, \$9. Among the creditors are the New York Talking Machine Co., the Blackman Talking Machine Co. and the New York Sporting Goods Co. At a subsequent court hearing J. Newcomb Blackman was appointed receiver, and will continue the business.

VICTOR CO. DISTRIBUTED TURKEYS.

(Special to The Talking Machine World.)

LAMDEN, N. J., January 9.—As has been its practice for some years past the Victor Talking Machine Co. on Christmas Eve presented each of its employes of the company with a turkey and a part of cranberries, 5,700 turkeys being distributed.

HOW TO APPROACH PROSPECTS.

Differentiating Between Cheap Sentimental Types, the Nervous, Sanguine and the Phlegmatic Types of Business Men.

How the salesman should differentiate in his approach between the three temperamental types of men, the nervous, sanguine and phlegmatic, was the subject of a talk given recently to a class in business efficiency and salesmanship in Boston. "The nervous type," said the speaker, "would become impatient if handled in a dilatory or long-winded manner. His brain is active, and every idea you give him will breed a dozen more instantly. It is necessary to make your approach brisk, businesslike and forceful. The sanguine type must be carried along by short, easy stages. Being fond of companionship and comfort, it is necessary for the salesman to interest him along these lines. The phlegmatic type is more difficult to approach, for he lets you talk and listens himself. As he is logical and practical, the salesman must know his goods and all that pertains thereto. "This type of man," says a writer in the New York Times, "will remember the arguments used, and should there be a difference in statements he will remember it and hold it against you, thus making the sale more difficult."

OPERATES PLAYER AND PHONOGRAPH

(Special to The Talking Machine World.)

WASHINGTON, D. C., January 8.—The Aeolian Co., of New York, N. Y., is the owner through assignment by Edwin S. Votey, Summit, N. J., of patent No. 1,082,218 for a Means for Operating Musical Instruments, and which consists of a means for operating two or more musical instruments together, and is particularly designed for the operation of said instruments together in the same musical time and harmony of pitch.

The embodiment of this invention is applied particularly to two musical instruments such for instance as a player-piano and a phonograph or graphophone, driven by means supplied with power from a common source, and comprises means associated with each motor for controlling the speed of the motor, and hence the musical time of the corresponding musical instruments as well as the pitch of one of the instruments. Broadly speaking, this means constitutes or effects in each case a tempo-control for each instrument, but obviously this means may be related or unrelated to the regular tempo-control already provided in connection with each instrument. Preferably the means of control provided are operable independently and separately.

NEW LOCATION FOR CABINET CO.

The C. B. French Cabinet Co., 401 Flushing avenue, has secured a plot of ground at Metropolitan avenue and the Long Island Railroad tracks near Bushwick Junction, Brooklyn, to erect a building for the manufacture of patent telephone booths and cabinets for phonograph concerns.

3 EASY SELLING SPECIALTIES For Edison Machines

EXTRA PROFITS are waiting for you, because every Edison owner can be interested in these attachments. Union No. 1 enables him to play Columbia and Victor records—the Union Modifier enables him to regulate the tone without changing needles—the Union Sound Box is designed to eliminate scratching.

UNION PHONOGRAPH SPECIALTIES

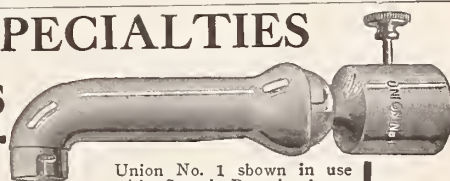

Union No. 1 shown in use with Sound Box in lower corner. Gold plated, \$5; nickel or oxidized, \$4.

Pat. No. 776-672, others pending

Union Modifier (quick attachable). Gold plated \$1.50; nickel or oxidized, \$1.

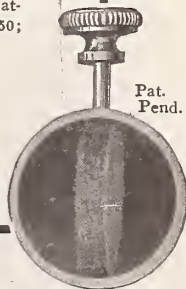

Pat. Pend.

Union No. 1 and Sound Box in use. Union Sound Box, gold plated, \$5; nickel or oxidized, \$4.

Pat. No. 776-672, others pending.

WRITE for our new completely illustrated catalog describing seven big sellers.

"Two Phonographs in One" AND DEALERS' PRICES. SENT FREE ON REQUEST.

The Union Specialty & Plating Co.

409 Prospect Ave., N. W.

Cleveland, Ohio

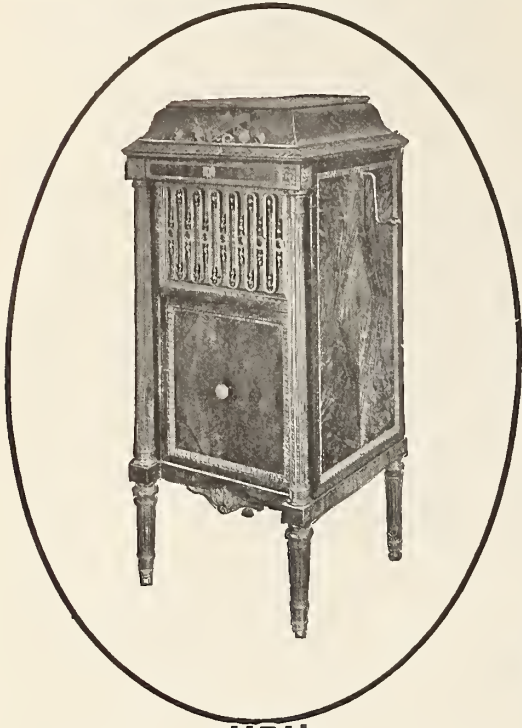

LOUIS XVI
 Model A450, Circassian Walnut, \$450.00
 Model A400, Mahogany, \$400.00



SHERATON
 Model A275, Mahogany, Inlaid Plain, \$275.00

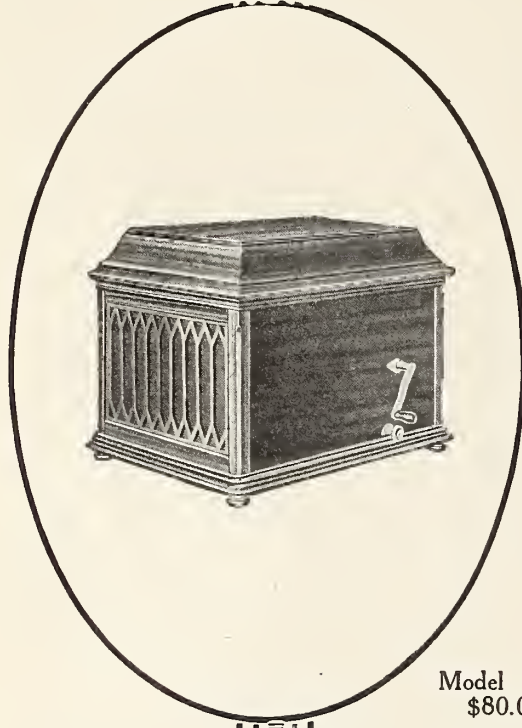

Model A80, Mahogany, \$80.00

The satisfaction of handling the complete Edison line

lies in being able to meet capably every situation that arises in the phonograph business. It means an equipment of various types that are adaptable to the man who can spend a good deal or the man who must spend but little. It means having the goods, in every sense of the word.

If a customer has a leaning toward the cylinder type, you can show him new models of

Edison Cylinder Phonographs

that express the most recent ideas in sound reproduction. This important side of the phonograph business has always been kept up-to-the minute in the Edison Laboratories. If he wants a disc instrument, you have the new

Thomas A. Edison, Inc.

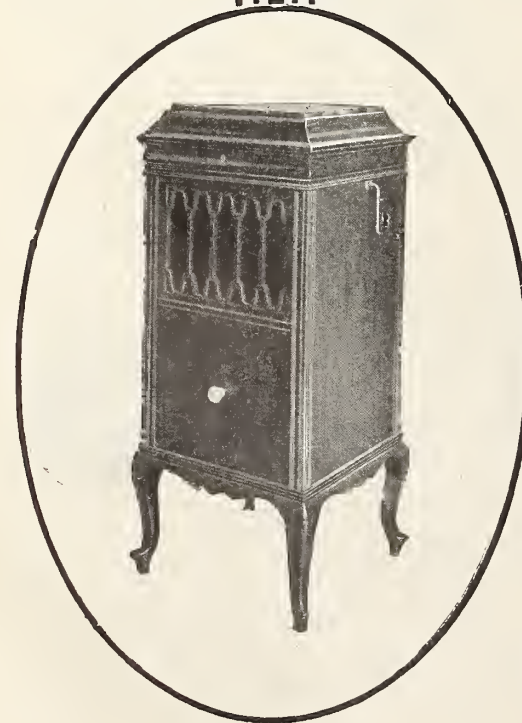

Model A200, Mahogany and Oak, \$200.00



Model A300, Circassian Walnut, \$300.00



SHERATON

Model A290, Mahogany, Inlaid Marquetry, \$290.00

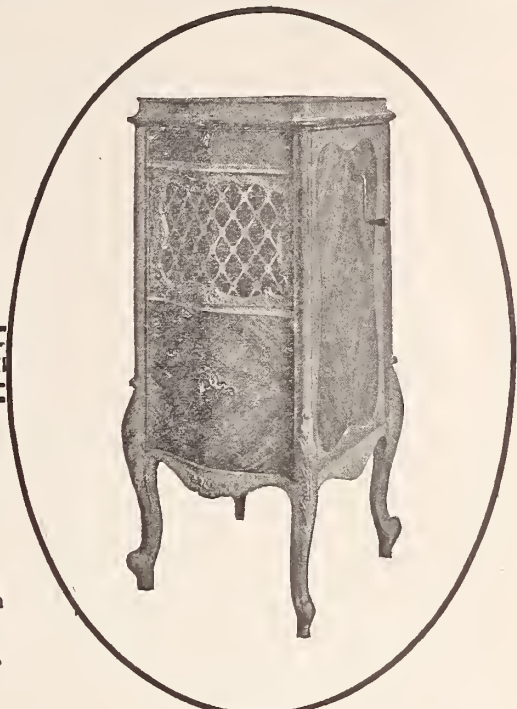

LOUIS XV

Model A425, Circassian Walnut, \$425.00
Model A375, Mahogany, \$375.00

Edison Diamond Disc Phonographs

upon which Mr. Edison has been at work for the past three years and in which are expressed the final perfections of the phonograph as a musical instrument.

The motors, with the uniform speed maintenance up to the last revolution, offer mechanical excellence that has never been approached. The cabinets, in a wider variety of beautiful woods than ever, are appropriate for the surroundings of any home or club or church.

Whoever your prospective buyer may be, in the Edison line there is a phonograph that will best suit his taste and his purse.

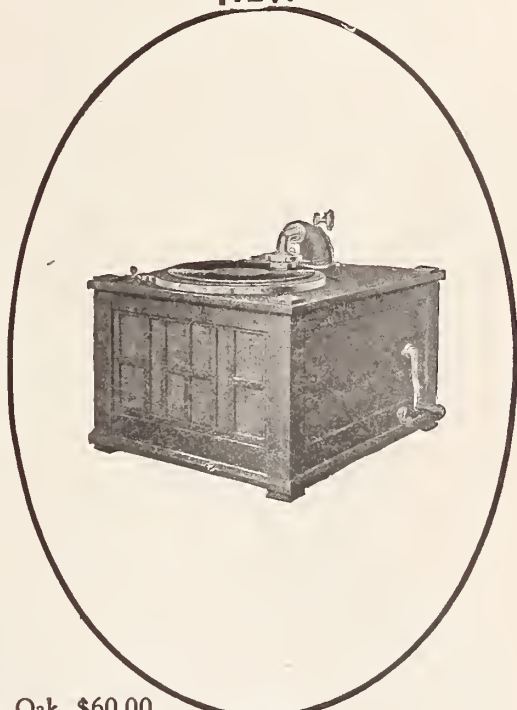

Model B60, Oak, \$60.00

59 Lakeside Ave., Orange, N. J.



Model A250, Mahogany and Oak, \$250.00



Model A150, Mahogany and Oak, \$150.00

TALKING MACHINE SALESMAN'S BOOK OF KNOWLEDGE.

Purchase Scrap Book and Jar of Paste, Mr. Talker Man, and Start an Encyclopedia of Phonograph Information for the Edification and Enlightenment of Your Customers—Some Valuable Hints Worthy of Consideration for the New Year.

There is a salesman attached to the establishment where I buy my records who bears a unique reputation. He is universally conceded to have the greatest store of talker news stored away along with the gray matter in his active brain of any man in town. In addition to the notoriety he enjoys from this source, it aids him tremendously in selling goods.

A great many times have I witnessed customers refusing to be waited upon by any salesman but Frank (his name is Frank), and in the event of his being engaged elsewhere, they would sit themselves patiently down in the showroom and await his return.

There is not a subject of interest in the talking machine world, be it old or new, that Frank cannot talk upon fluently and well. Ask him a question regarding the salary of an artist, the latest march by Sousa, or the color of Ada Jones' eyes, and he will not only answer you correctly, but throw in some entertaining attendant anecdote for good measure.

Such a salesman is most valuable to his employers, and, therefore, capable of commanding a remunerative return for his services.

Why not follow Frank's example, Mr. Dealer, and familiarize yourself with all things phonographic, which at some future time may prove of interest to your patrons? There is not a day goes by that does not bring to you, through the medium of the newspaper or magazine, some bit of information well worthy of a place in your salesman's book of knowledge. For instance, it is most satisfying when a physician calls to inspect a machine, for amusement purposes only, to find yourself in a position to converse technically regarding the effects of different kinds of music upon the sick, and to convince him that not only will the talker

be a source of entertainment and delight to himself and family, but of vast value to him in his practice as well.

Tell him of the views of Dr. Leonard Keene Hirshberg, A.B., M.A., M.D. (Johns Hopkins), upon this subject. "There is no doubt," says Dr.



Why Frank's Services Are Sought.

Hirshberg in the Philadelphia Evening Telegraph, "that music, like other emotion stirring stimulants, plays, at times at least, a fair share in the medical aids that go toward the restoration of health. If the musician's touch is tender, full of emotion and vibrating with sincerity, Beethoven seems to

act as an ideal tonic upon the sick. On the other hand, the current ragtime melodies popular with these same patients when they are well pall upon them and irritate them when sick."

He then speaks of Miss Alice E. Gether, an accomplished pianist, and describes her experience with music as a curative agent in the hospital as follows: "The day she left the institution a request came from a patient, whose recovery a few days before had been very doubtful, to please have her piano moved near her room and to play Schumann's 'Träumerei' for her. This was done, and the patient took a turn for the better and recovered."

When you have told him these things which he did not know, he is not only amazed, but does some hard thinking as well. In the end, instead of selling a single outfit to the man of medicine, you sell several to his hospitals also. You have, through the agency of your book of knowledge, opened up a new field, and that, of course, means more business and greater financial returns.

Now that the medical fraternity in its relation to the talking machine industry has been sufficiently touched upon, we will turn another page of our scrap-book.

* * * *

A cylinder record was playing softly, the melody floating through the grill of the Amberola with dreamy sweetness. "When It's Apple Blossom Time in Normandy," sang the artist, his golden tenor soaring high above the querulous voices of two angry customers. I like that song immensely, so I paused to listen.

"That's Irving Gillette singing, I tell you!" declared one of the irate patrons, positively.

"You're wrong!" snapped the other fiercely. "Don't you suppose I know a voice when I hear it? I want you to understand, sir, that I have been an authority on singing for twenty-five years, and, furthermore, I have a dozen disc records in my cabinet at home this very minute with that voice on them."

Then, glaring belligerently at his opponent, he snarled, "If that isn't Henry Burr's tenor on that record, By Gad! I'll eat it."

"If my eyes do not deceive me, brother, you have a tough meal before you. The name of Irving Gillette is stamped upon the box lid."

"I don't give a —!"

"What is the difficulty, gentlemen?" interrupted the salesman (our friend Frank) arriving with a tray of best sellers.

"Difficulty enough!" roared the debaters in unison. "This man"—each glaring at the other—"don't know a voice when he hears it!"

"Irving Gillette for the Edison, Henry Burr for the Columbia and Victor, and Harry H. McClaskey in private life," explained Frank succinctly. Both were right—war was averted.

From interesting a professional man, by a chat with him in his own language, to settling an argument as to the identity of a singer, is a far cry, but your scrap-book of talker facts will enable you to do either equally well.

Oh, there is no doubt, Mr. Dealer, about this book of knowledge idea being a trade bringer.

Just a bit of advice in conclusion: When your next customer calls to hear a certain record, surprise and delight him by indulging in a brief resumé of the artist's life; or, if you prefer, speak of a memorable incident in connection with the composer of the selection.

Your patron will be most appreciative and delighted because, through your courteous explanations, he is able to add very materially to the enjoyment he has previously derived from his instrument.

He will speak of you to his friends as an authority upon everything in talkerdom. He will tell them also of the pamphlet of artists' biographies, meaty kernels of news, and valuable hints, he is compiling with your able assistance, and suggest that they come and do likewise. Why, if every talking machine man in the country would cultivate the fine art of entertainingly instructing his customers regarding the many subsidiaries of the talker, the industry would enjoy a greatly enhanced prosperity. Do you not agree with me?

HOWARD TAYLOR MIDDLETON.



Won't You Have a Lesson in Spanish?

It's so easy to learn by the I. C. S. system—and a knowledge of Spanish is so useful nowadays.

The I. C. S. system of language instruction by means of the phonograph makes easy the mastering of a foreign language, and appeals with compelling power to thousands. The dealer in phonographs who does not carry I. C. S. Language Outfits is neglecting a quick and sure way to increase his business. The new \$35 Language Outfit of the I. C. S. is a marvel. It represents the highest art in the teaching of languages, and embodies a method that has won the warmest praise of thousands qualified to speak authoritatively. The Spanish, French, and German Embassies at Washington, as well as the leading colleges, have cordially indorsed the I. C. S. method of teaching languages.

The I. C. S. Language Outfit consists of an Edison Gem Phonograph made especially for language work; small horn; headband hearing tube; oil can; and 25 Conversational Records teaching pronunciation guaranteed to be absolutely correct, with native intonation and inflection. In addition to these Conversational Records there are pamphlet Instruction Papers teaching the theory of the languages. The new Outfit is at one and the same time the best and cheapest ever offered—the price being only \$35.

If you want to increase your business, write to-day for full particulars.

International Correspondence Schools

Box 918, Scranton, Pa.



1913 was a great year for Columbia Double-Disc Records—the greatest we ever had. 1914 will be twice as great. That much we can already see coming. Watch it. But watch it from the inside looking out, not from the outside looking in.



(Write for "Music Money," a book "full of meat" for those dealers interested in quick and frequent turnover of capital.)

Columbia Graphophone Company
Woolworth Building, New York

SOME NEWSPAPER MISSTATEMENTS SET RIGHT.

Recent Report of Suit of American Graphophone Co. Against the Parlograph Co. Led to Some Statements Being Made That Are Misleading—Statement from the Counsel of the American Graphophone Co. Is Important and Informative in This Connection.

The talking machine industry was greatly interested in the published account of a dictating machine lawsuit which appeared in the New York Sun recently, wherein the American Graphophone Co., manufacturer of the Dictaphone, asked for an injunction against the American Parlograph Co., manufacturer of the "Parlograph," another dictating machine of foreign manufacture. This injunction was denied, as the American Graphophone Co. had expected, but in publishing the account of the trial the Sun apparently made some deductions which were not based on the facts at issue.

The headings of the story, prominently displayed in usual newspaper style, in bold-face capital letters, read: "Bars to foreign phonographs down—Dictaphone makers lose suit to keep out German 'Parlograph'—Edison patents expired—Open field for devices and records is expected to cut prices."

The remainder of the article under the above startling headings read:

Through the denial by District Court Justice Holt, an application by the American Graphophone Co., manufacturers of the dictaphone, for an injunction to restrain the importation and sale of a German machine known as the parlograph on the ground of patent infringements, it became known that the American field is now open to foreign talking machines.

The decision is said to form the opening wedge for the importation of all foreign talking machines and records, and means an eventual cut in the price of both business and musical phonographs.

The decision is said to be the first in which the American manufacturers have failed to keep foreign machines out.

The defendant was the American Parlograph Co., of 2 Rector street, American agents for the Carl Lindstrom Co. of Berlin, who were warned before the suit that the parlograph was an infringement. The defendant referred the matter to its attorneys, Cabell & Gilpin, of 11 Wall street, and made contract to sell 1,000 machines. Then the suit was brought.

The American Graphophone Co., through its attorneys, Mauro, Careron, Lewis & Massie, alleged that the defendant's machine infringed on a patent of Thomas H. Macdonald, of Bridgeport, Conn., and upon patents of John H. J. Haines and Elam Gilbert. In the argument the plaintiff relied solely upon the Macdonald patent.

Shelton F. Cameron, a patent lawyer, of counsel for the plaintiff, said in an affidavit that he has made a specialty of the art of producing sounds, and that he found in the parlograph every feature claimed by the Macdonald patent.

Edward D. Easton, president of the American Graphophone Co., and the Columbia Graphophone Co., said that for years prior to 1896 his company was in litigation with the Edison companies. In 1896 this was settled and contracts entered into which are still in force, under which each agreed to keep to its type of machine.

The answer of the defendant said that the alleged invention was used by Edison and many others before it was patented by Macdonald, and that the letters patent didn't describe an invention but a "mechanical expedient."

The defendant also alleges that the contract between the American Graphophone Co. and the Edison Phonograph Co. is in violation of the Sherman anti-trust law.

Philip Mason Cabell, president of the defendant company, said that it is a matter of common knowledge that the graphophone was invented by Edison in 1880, and that his patents have long since expired. He said that other machines merely differ from the Edison machine in mechanical structure, and that so far as the principle is concerned America is an open market.

Judge Holt denied the application for the injunction without writing an opinion.

When seen by a representative of The Talking Machine World, C. A. L. Massie, of the firm of Mauro, Cameron, Lewis & Massie, counsel to the American Graphophone Co., stated that the newspaper account was somewhat overdrawn, and dictated the following statement in order that the

trade might be properly informed regarding the true status of the points of law at issue:

"BARS TO FOREIGN PHONOGRAPHS NOT DOWN."

"The American field has not yet been opened for invasion by foreign talking machines. The American Graphophone Co. has recently brought suit against a German dictation machine known as the 'Parlograph,' as an infringement of no less than five different United States patents. This suit has nothing to do with disc machines, or with 'records' of any kind, or with musical machines.

"The suit will be prosecuted vigorously, in the usual manner; and is expected to result in a permanent injunction, and the defendant will have to account to the Graphophone Co. and pay over to the latter its own profits and also the damages resulting from the infringement. Under the law the Graphophone Co. can also proceed against every user of the infringing machines.

"With one exception, these five patents have many years to run. The Macdonald 'overhanging mandrel' patent, however, will expire in the coming spring. For that reason, and also because of the long public acquiescence in the validity of that patent, the Graphophone Co. ventured to seek a 'preliminary injunction' in advance of the trial—even though there has been no 'prior adjudication' in favor of that patent. All five of these patents have hitherto been respected, so that the Graphophone Co. has not heretofore been called on to bring suit to enforce them; and consequently there has been no 'prior adjudication' concerning any of these particular patents.

"Ordinarily, the Federal Courts refuse preliminary injunction upon a patent that has not already been sustained by some prior adjudication. Of course, there was no ground for asking preliminary injunction upon any of the other four patents sued on; yet the Graphophone Co. had hoped that the court might decide to grant preliminary injunction under the Macdonald patent, which expires so shortly.

"However, this case proved no exception to the general rule, United States Judge Holt handing down a memorandum decision which reads: 'I think that the case made on these papers is not so clear and decisive as to justify a preliminary injunction under the practice in patent cases. Motion denied.'

"Judge Holt's decision is in line with the usual reluctance of the Federal Courts to grant preliminary injunction before trial, and does not in any wise effect the merits of the controversy or foreshadow the outcome of the suit."

"The twentieth century was born without a memory—it's so busy with to-day's achievements and to-morrow's projects that no one has time to remember yesterday's exploits."

HISLOP CO. SECURES EDISON LINE.

(Special to The Talking Machine World.)

NEW LONDON, CONN., January 8.—The agency for the Edison disc phonograph has been placed by J. W. Scott, representative of Thomas A. Scott, Inc., with the James Hislop Co., for this city and vicinity. A large initial order was placed. Much interest has been manifested in the Edison disc, owing to the recital given by Mr. Scott in the lobby of the Mohican Hotel last Sunday afternoon. This is the first time that the Hislop company has handled musical instruments, and it is making the public acquainted with its plans in imposing announcements in the local newspapers.

SECURE EDISON DISC AGENCY.

(Special to The Talking Machine World.)

NORWICH, CONN., January 8.—The Porteous & Mitchell Co. has secured the exclusive agency for the Edison disc phonograph in this city and vicinity, and a full line of these instruments are now being displayed in the company's handsome new musical department. In connection with the opening some striking advertisements were carried.



builT likE a watcH
artistiC, cleveR, compacT
togglE joinT, powerfuL
iT does noT sheeR
iT cuts
retainS chips

noW iN thE hands
oF youR jobbeR

**Standard Gramophone
Appliance Co.**

173 Lafayette St., New York

The **TALKING**
MACHINE
WORLD

For the makers & sellers of talking machines

EDWARD LYMAN BILL, - - - Editor and Proprietor.

J. B. SPILLANE, Managing Editor.

Trade Representatives: GLAD. HENDERSON, C. CHACE, L. E. BOWERS, B. BRITAIN WILSON, A. J. NICKLIN, AUGUST J. TIMPE, L. M. ROBINSON.

Boston: JOHN H. WILSON, 324 Washington Street.
 Chicago Office: E. P. VAN HARLINGEN, 27 So. Wabash Ave.
 HENRY S. KINGWILL, Associate.

Philadelphia: R. W. KAUFFMAN. Minneapolis and St. Paul: ADOLF EDSTEN.
 San Francisco: S. H. GRAY, 88 First St. Cleveland: G. F. PRESCOTT.
 St. Louis: CLYDE JENNINGS. Cincinnati: JACOB W. WALTER.
 London, Eng., Office: 2 Gresham Buildings, Basinghall St. W. LIONEL STURDY, Manager.
 Representatives for Germany and Austria: VERLAG NEC SINIT, Berlin C. 19, Ross-Strasse 6, Germany. Geo. Rothgeiber, Director.

Published the 15th of every month at 373 Fourth Ave., New York.

SUBSCRIPTION (including postage), United States, Mexico, \$1.00 per Year; Canada, \$1.25; all other countries, \$1.75.

ADVERTISEMENTS: \$3.00 per inch, single column, per insertion. On quarterly or yearly contracts a special discount is allowed. Advertising pages, \$100.00.

REMITTANCES: should be made payable to Edward Lyman Bill by check or Post Office Money Order.

NOTICE TO ADVERTISERS.—Advertising copy should reach this office by the first of each month. By following this rule clients will greatly facilitate work at the publication headquarters.

Long Distance Telephones—Numbers 5982-5983 Madison Sq.
 Cable Address: "Elbill," New York.

NEW YORK, JANUARY 15, 1914.

AT the beginning of the year most of us are apt to indulge in a little retrospective and prospective thought, and it is the aim of every business man to remedy certain policies which have been pursued in the past which have not proven their usefulness in a business sense.

What policy can be best adopted to make the talking machine business better for 1914?

Have our practices and methods been thoroughly up-to-date?

Are there any weaknesses which are discoverable when we analyze our various policies and systems?

These and other queries along similar lines will be considered by talking machine men everywhere.

The industry has great possibilities and are we all making the most of them? That is the question!

That the present position of the talking machine has advanced commercially, artistically and nationally, cannot be too strongly emphasized, for this broadening out in every department of life means greater expansion of business for those whose financial interests are interlocked with the industry.

The growing importance of the talking machine everywhere makes necessarily for the business advance of the men who are interested in disposing of these popular creations.

Sometimes we feel that some of the talking machine dealers throughout the country do not realize the importance of the product which they sell as an educational and instructive factor.

For quite a period a large proportion of our population viewed the talking machine as a product the existence of which would be ephemeral. They did not take it seriously, but all that is changed. Artists internationally famous, in both the vocal and instrumental field, are now being heard through the aid of the talking machine in the homes of people who never without its mediumship would have become acquainted with good music.

IT means the best in music has been carried from the concert stage to the parlor, and that our great singers and instrumentalists and our great orchestral organizations are now heard in every home, thus aiding the musical education of the people; helping to a keener appreciation of good music, and teaching them how to enjoy music in the home in a manner never before possible.

Then, if we consider the manufacturing department, it must be admitted that the output has been vastly increased, for year by year the manufacturing facilities have been greatly augmented. In fact, the increase in the manufacturing department has been as rapid as we could reasonably expect.

It is impossible to create a great factory over night, and when

we view the great plants, limited in number, but vast in space, it must be admitted that the manufacturers of talking machines have made every reasonable provision to take care of their trade with promptness and despatch. But notwithstanding these great plants involving the outlay of vast capital, they have been unable to keep up with the demand because by the aid of advertising running into colossal figures, the public has been more and more educated to the possibilities of the talking machine, its entertaining powers and its value as a home entertainer. Hence, the demand has been increased in a phenomenal manner.

THEN another point which is of vital importance is the stability which has surrounded the trade through price maintenance.

Every man in the talking machine trade has had the advantage of nationally advertised products and has had a price protection which has been of infinite value. A condition of price cutting and business disturbances have thus been happily and wisely avoided. And yet notwithstanding these unusual conditions of strength and stability there are retailers who, by their public exploitation, are doing things which would seem to us are not warranted by the conditions which surround the talking machine industry.

Take, for instance, a public exploitation in which talking machines are offered on terms which are not in accordance with sound business methods, and which seem to us to be superfluous and un-called for.

According to the advertising announcements of a department store, one dollar will place a \$15 machine and \$9 worth of records in the homes of purchasers. Future payments can be made at the rate of fifty cents.

A \$5 payment will place a \$100 machine and \$10 worth of records in the home of the user, and a \$10 note puts a \$200 machine and \$10 worth of records in the same place.

Do not merchants who sell on such a basis strike a blow at the stability of the business everywhere? Why pay cash, even if you have it, when such terms are thrust at you?

The men who put out pianos at nothing down and a dollar a week have long ago become convinced of the ruinous pace they were traveling, and the talking machine business which has to-day but three producing houses and no such competition as exists in the piano industry, yet some of the merchants deliberately violate all rules of business soundness in their evident anxiety to do business.

We should bear in mind, too, the fact that such offerings affect the entire trade. They establish a standard of selling terms which is liable to be put up to talking machine men in every city and every hamlet throughout the land.

What in the name of common sense, when there are not enough goods to go around, is the use of offering a man a machine worth \$200 and \$10 worth of records for a ten dollar note?

The buyer can use the machine a month with the records and then return it. The returned machines are sold again as new. Is this right?

What is the machine but a used product, and how much are the records depreciated?

Furthermore, does anyone believe for a moment that there are not many people who would take advantage of such terms who do not, at the time they order the machine, expect to keep it beyond a very limited time?

Again the advertisers deliberately turn a cash business from their own establishments by such offerings.

Why should a man pay cash for a talking machine when he can get one for a few dollars per month? Why not run over a period of a couple of years in his payments when it costs him no more?

Such advertising hurts in more ways than one, for it creates a long time small payment credit business out of what otherwise might prove a near cash transaction, and it tells the man who has the cash that he need not pay it save in homeopathic doses over a long period. Is that good business?

What is the advantage of offering a hundred dollar machine for \$5 a month and a bunch of records included?

Under those conditions the purchaser who desired to have a talking machine in his home during the holidays, could secure a good machine and a few records before Christmas, and after a month's use decide that he does not desire the machine, return it with the records, and gets his money back. Can you beat it? Not very well—machine, records, music for a month at no cost.

Now, does anyone for a moment doubt that there are not plenty of people who will abuse such generosity.

The bait is too good—too alluring—and many will snap at it because it has been put forth by department stores of reputation and standing.

Is there any reason why talking machines should be offered on such terms?

THEN, again, what becomes of the used machines under such conditions? Surely reverts are put out again and are they not sold as new machines? And the records, too, may be badly damaged.

This kind of appetite whetting advertising is a greater disturbing factor than many think at the first blush.

The great metropolitan papers containing notices of such allurements reach the smaller towns, and possible customers go into the talking machine merchants and show them the advertisements put forth by the department stores and ask the local men why they cannot do as well as they in terms. Then they follow up with the threat that they will do their buying outside of town if the small merchants cannot meet competition regarding terms as well as prices.

What is the result?

The dealers in the small town have to use some convincing line of arguments, or they have to make concessions which they would not be compelled to do in order to close sales.

Now, this unsatisfactory and unwholesome condition is needed, because there is no industry in the world that is as well protected, as well fortified in every way, affording ample protection to the jobber and retailer as the talking machine business. Yet, here are some houses that deliberately jump in, and while they do not flaunt low prices, they annihilate sound business principles by offering allurements which are not justified under the existing conditions.

THEY help to create a condition which makes it harder for the small merchants to do business than before, and up to the present time one of the splendid advantages of the talking machine business is the fact that it afforded the small man—the man with limited capital—an opportunity to do business on equal grounds with the big house controlling millions.

That has only been possible by fixed prices, and now some of the houses which are handling talking machines are endeavoring to increase their business by offering inducements of a nature which are merely must be unprofitable for themselves, and which will have a reflex effect upon the entire trade.

Is there any profit in giving a man a \$100 talking machine with 100 worth of records for a month for a five dollar note? There is no profit in the salesman's time, the cartage both ways, the pro rata selling costs and simply a gamble on the man's keeping it, and even if he does, why is it necessary to emphasize too long a period in which the talking machine instalments may run?

Why harp upon the long selling time when there are not enough talking machines to go around to-day?

THERE are some business moves which we fail to understand even though they may be put forth by great and successful houses.

We see no reason why the selling time should be extended under conditions which are contrary to sound business principles.

Such methods are not in harmony with the principles which have protected the trade through the enforcement of rules holding the price maintenance to a point of unyielding rigidity.

Talking machines are profitable to handle and the retail purchaser secures excellent value. In other words, it is a perfectly fair arrangement all around, and it is absurd to offer a kind of bait to purchasers which creates the impression that talking machines may be purchased at any kind of prices and terms.

It injures the business in that it creates the impression in the minds of readers of the advertisements that talking machines can be purchased on almost any terms and conditions. Therefore, the impression would then be formed that the prices at which the machines are sold afford unusually large profits to the retailer, else such allurements would not be made. This is creating a false impression.

TALKING machines should not be handled as a baiting piece of merchandise, and the impression should not be created that one house can violate legitimate merchandising conditions in order to attract customers to its establishment, with perhaps the hope that the customer will be impressed with the ability of the house to supply cut rates on some other lines of merchandise than those advertised.

It may be urged that such advertisements injure no one, but in our opinion they injure the entire trade and they impose a heavier burden upon dealers everywhere to meet such unbusinesslike offerings. The talking machine business is a wonderful industry, and the men whose interests lie therein should not, through alluring price offerings, aid to introduce a baiting element which may work out disastrously to the entire trade. There can be no annihilation of selling terms without the entire trade feeling the effects of such a move.

A PARTICULARLY interesting endorsement of the position, as an amusement and education factor, now reached by the talking machine is that contained in the recent announcement of an extra allowance of \$82,500 granted for army post exchanges by Congress at the instance of Secretary of War Garrison. The amount as divided will provide a fund of \$1,245 for each army chaplain with which he is expected to obtain a talking machine and a suitable supply of records, a motion picture machine with slides and films and a tent with adequate seating facilities in which to give entertainments for the amusements and benefit of the enlisted men.

The fact that the appropriation will result in the purchase of sixty or more machines with several hundred records, is not so important to the trade at large as the fact that Congress, through the influence of the Secretary of War, displayed its appreciation of the value of the talking and motion-picture machines as a means of making the lot of the enlisted soldier more pleasant, to the extent of making a generous appropriation for the purchase and maintenance of such equipment.

Recognition by the Federal government of the value of the talking machine as a means of entertainment for soldiers is a tribute that should prove a sales-producing argument at the hands of the wide-awake dealer, for Uncle Sam, in buying supplies, doesn't bother with experiments, but demands goods of accepted worth and quality, whether it is a matter of blankets or amusement devices. The adoption of talking machines by the army is just another indication of the rise of the talking machine from the point where it was a novelty of the freak order and the butt of humorists to its present forward position in the field of music.

Through the medium of the talking machines the enlisted men can listen to their favorite selections, whether grand opera or rag-time, and when the men at one post after months of use become tired of their stock of records they can be exchanged for those of another post until the records are worn out. With talking machines in public institutions of all kinds, schools, colleges, army posts, etc., and in hundreds of homes throughout the country the energetic advertising and sales campaigns have surely brought results.

IT is better to prevent credit evil than to attempt the remedy after the evil is done, so declares Edward S. Mills, who at one time managed the adjustment bureau of the Philadelphia Association of Credit Men, who says further that the chief reason for tardiness by merchants in the payment of their bills may be found in a "lack of business ability and management," and therefore it is of the highest importance for the credit man to keep in close touch with his tardy accounts and make it his business to educate them and warn them against their mistakes.

"In this way," Mr. Mills adds, "slow accounts can often be developed into very profitable ones, and the credit man who considers his duty done when he simply passes upon an account and then tries to get his money out of it has no proper conception of the credit man's sphere, for he should make it his interest to find the flaw in his customer's business." He cites one house that looked upon this as a matter of such importance that it had a force of trained men whose duty it was to call upon its customers in order to show them how to take and keep track of stock and accounts and how to supervise their business generally, and this concern had been instrumental in saving and making profitable businesses out of what otherwise would have been failures.

Better Value than Other Albums by Reason of Superior Quality

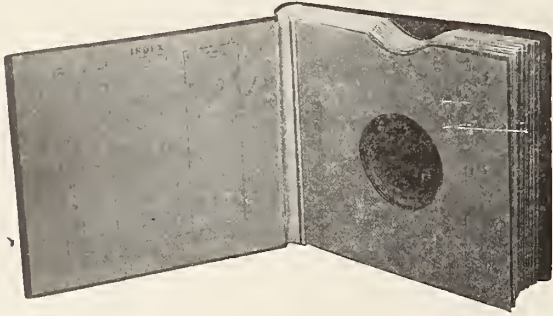

Our Albums are bound **correctly** by expert hands. **Envelope pockets** are constructed of very tough **Dark Green Fibre** paper. Albums are bound in best **Mahogany Imitation** leather, gilt stamping on face and leather or gold-plated ring pulls as desired. Made for 10 and 12 inch discs. Write for sample and prices, which will convince you, as they have all our other customers, of the superior quality and value of our albums.



These albums are constructed with a view to **Strength**, so that they will really hold the **full** complement of discs, and give excellent service.

NEW YORK POST CARD ALBUM MFG. CO., 23-25 Lispenard Street, New York

OPTIMISM IN THE TWIN CITIES.

A Great Holiday Business Transacted by the Talking Machine Houses and the Percentages of Increase Given Out Would Seem Extravagant Were They Not Supported by Irrefutable Testimony.

(Special to The Talking Machine World.)

MINNEAPOLIS AND ST. PAUL, January 6.—If ever the talking machine and phonograph dealers of the Twin Cities lived in clover it was in the holidays and the contiguous days fore and aft. Some of the statements handed out to your correspondent in his merry round read extravagant like, but there is no question but that they were in clover, head high and luxuriant. The extent of the business was limited only by the ability to obtain goods.

"We lost many retail sales and many local orders because we could not supply the goods," remarked W. J. Dyer, head of the big house which bears his name and an extensive jobber in Victor products. "Of course, it is much better to clean out your stock and make ready for new goods than to carry a big line over the season, but it is aggravating to be compelled to refuse actual money. Some day, probably, we will have stock enough to meet the demands, but I imagine that just for the present the talking machine trade is growing so rapidly that the manufacturers are unable to keep the production up to the pace of the demand. We will continue our Victrola and Pianola recitals every Friday night, as these have become a regular musical institution in St. Paul and draw large numbers each week."

"Nearly 300 per cent. increase" is the comparison made by the Minnesota Phonograph Co. between December, 1913, and the previous December. "Had we taken in \$1,000 more," explained Laurence H. Lucker, manager, "we would just have trebled the business. We received six carloads of Edison instruments just before Christmas and one carload after, and nearly everything has gone and we are about a hundred machines behind in our orders. Much of the business was high grade. We sold

one \$400 and one \$450 Edison way out in North Dakota, which serves to illustrate how the fame of the Edison instruments is spreading."

At the Columbia headquarters in Minneapolis Jay H. Wheeler, manager, still was so busy that he did not have time to stop and talk about the business, but in this case no news doubtless means good news.

Archie Matheis, of the Talking Machine Co., has not recovered from the holiday rush, and still is hustling, but halted long enough to announce that his December trade was greater by 150 per cent. than during the previous December and, of course, he is pleased. Mr. Matheis handles both Victors and Edisons.

Foster & Waldo, who have been pushing their Victor department with much energy of late, have reaped a rich harvest therefrom, and are highly pleased that they have done so, as the sales in recent weeks have been tremendous.

One of the handsomest display windows in either city during the holidays was that of the Columbia store in St. Paul, which was arranged by C. P. Herdman, manager. It contained types of seven machines, from \$25 to \$275, with a decorative arrangement of holly, smilax and palms. After a big rush of trade there was not a \$75 or a \$100 machine in the house, only one \$150 machine, not a single mahogany type except two at \$250, and that is being cleaned out right.

VICTOR PUBLICITY FOR JANUARY.

The Victor Talking Machine Co. sent out to its dealers late last month its usual batch of valuable literature to assist them in developing January business. Proofs of the advertisements to be used by the company in the newspapers throughout the country, record hangers, and the customary proofs of magazine advertisements for January were included in the batch. The proof of the company double page spread in the Saturday Evening Post of January 17, shows an advertisement of exceptional merit and beauty.

The maintenance in popularity of the tango and

the ability of the Victrola to adequately cater to the demand for this type of record, is referred to particularly in the letters accompanying the new Victor publicity, together with the suggestion that the vast amount of new machines sold during the Christmas season opens a new market for the sale of additional Victor records.

MOVING PICTURE SLIDES.

In Connection with New Advertising Record Issued by Columbia Co. an Aid to Dealers.

In order that Columbia dealers may reap the full benefit of the value of the new advertising record recently issued by the Columbia Grapho-

phone Co., a number of publicity stunts have been introduced by the company's advertising department during the past few weeks. Live-wire pamphlets, car cards and moving picture slides have all been among the recent publicity presented by the company for the attention of Columbia dealers. One of the important helps offered is the motion picture slide shown in the accompanying illustration. This slide is meeting with success wherever it is introduced, and dealers throughout the country are ordering it.

READY REFERENCE OF GENERAL SUPPLIES

DEALERS

Send for our "Trial Proposition" on the Regina Hexaphone—the latest and best paying popular priced coin-operated instrument for use in public places.



211 Marbridge Bldg., 34th St. and Broadway, New York City
Manufacturers of Regina Music Boxes; Reginaphones; Coin-operated Mandolin Orchestrions; Vacuum Cleaners and other specialties.

Mermod & Co.

505 Fifth Avenue New York

Manufacturers of

Talking Machine Supplies

Motors—Sapphire Points

A Specialty

Keep Your Record Stock with



Costs about \$2.00 for 250 records for 50 years
Send for 20-page catalog

THE SYRACUSE WIRE WORKS,
SYRACUSE NEW YORK



The new Columbia dance records are absolutely in strict dance tempo, and why shouldn't they be? They have been recorded under the direction of the highest authority on modern dancing—Mr. G. Hepburn Wilson. Ask for the new Columbia dance circular.



(Write for "Music Money," a book "full of meat" for those dealers interested in quick and frequent turnover of capital.)

Columbia Graphophone Company
Woolworth Building, New York

AT THOS. A. EDISON'S OLD HOME.

Mrs. Ilsen Takes New Disc Phonograph to Old Edison Homestead in Milan, O., and Gives Concert for Benefit of Mr. Edison's Cousin "Twinsy," Who Tells of "Alvie's" Boyhood.

(Special to The Talking Machine World.)

CLEVELAND, O., January 8.—From the depths of a massive Edison disc phonograph, looming out of all proportion in a tiny "6 by 7" bedroom, floated the beautiful old "heart song," carrying with it the rare, gripping sentiment of a lifetime.

For the little bedroom, in the unpretentious old-fashioned cottage at Milan, O., was the room where the greatest mechanical and electrical genius of all time, Thomas A. Edison, first saw the light of day 66 years ago.

And just outside in the front parlor—the huge mahogany cabinet filled the bedroom—the "old folks" listened, with heads almost reverently bowed, to the most perfect reproduction of the human voice obtainable—the result of 35 years' unceasing study by the "big-headed boy" they all knew so well.

Memories Bring Tears.

The last strains died away. The old home "where the old folks stay" was silent. Then the lovable, white-haired cousin of the wizard inventor, Mrs. Nancy Elizabeth Wadsworth, named by Edison's mother and nicknamed by Edison himself "Cousin Twinsy," broke the awed hush.

"It's too wonderful, isn't it?" she asked appealingly. "He's just the same little Alvie to me; I can't think of him as the mighty, wonderful man the world sees."

And throughout the long, wonderful day, Thursday, when "Alvie" came back to the "old home" through the medium of his talking machine, the eighty-year-old boyhood confidante of the twentieth century's superman just marveled and voiced her pride in her wonderful boy.

Mrs. Isa Maud Ilsen, the first woman ever to represent Edison, who has been giving recitals in Cleveland to demonstrate the new Edison diamond-disc phonograph—probably the inventor's greatest achievement—conceived the idea of taking the beautiful product of his brain into his boyhood home in Milan.

So Milan and the home folk enjoyed a red letter day in history—and, most of all, "Cousin Twinsy," whose pretty ringlets of gray hair fell occasionally over the eyes that never lost their prideful glow.

"Oh, you've forgotten the horn," Mrs. Wadsworth exclaimed when the phonograph had been unpacked. The explanation that the horn was ingeniously concealed left the aged woman mystified at the wonders wrought from her Alvie's abnormally large head.

Tries to Hatch Goose Egg.

"Of course, I never dreamed Alvie would be such a great man, but I always knew he'd succeed," related Mrs. Wadsworth joyously.

"The day his father went out on that green hill over there and pulled him off a stump where he'd turned purple with cold while he was sitting on a goose egg to hatch it, I said it showed he was thinking of things.

"But I was young and Alvie got a whipping just the same.

"However, when Alvie took a boy, who lived in that house across the road, and filled him all full up with seidlitz powders to make him fly, I almost believed what his teacher said about him being addled.

"Oh, how I wish Samuel—that's his father—could have lived long enough to see how high Alvie's gone in the world—doing things for humanity. Alvie's pa always said 'his head's too big.' Alvie did have a large head, the largest I ever saw on a boy of his age."

Several of the old songs restored her youthful pertness. First, she examined the great instrument standing in Alvie's room.

Makes Good Early Promise.

"Alvie once said to me: 'I'll make iron and wood talk some day, Twinsy,'" Mrs. Wadsworth remarked suddenly, arousing from a reverie of retrospection.

"He's done more than keep his word, hasn't he? It seems as though he must have been living for centuries to do all he has—but I keep seeing the little boy I put to bed."

The cottage proved far too small to house the old friends and neighbors, so sentiment had to be waived a little, and the library secured for an evening recital.

Two hundred of the 700 population appeared on two hours' notice. Twinsy and her daughter Metta were both there.

"To think I used to pull his hair and stick my tongue out at him," gasped a "girl" of seventy-five, Mrs. A. J. Barney. Memories and anecdotes of Edison were murmured admiringly.

BUILDS UP LARGE VICTOR TRADE.

Wm. K. Kaplan & Co., Jamaica, N. Y., One of the Most Successful Talking Machine Houses in Vicinity of New York.

One of the most successful of the talking machine houses in Queens County, N. Y., which constitutes one of the boroughs of Greater New York, is that of William K. Kaplan & Co., 316 Fulton street, Jamaica, who in summing up the business of the company for the months of November and December, just past, state that it shows an increase of nearly 100 per cent. over that of the same period of 1912, and the quality of the business is also a most pleasing factor, the higher priced machines and records being in greatest demand.

In order to take care of its growing business the company has just completed the remodeling of the rear section of its store for the purpose of making room for extra demonstration booths for the Victrolas. An entire new lighting system has also been installed. In addition to Victrolas, W. K. Kaplan & Co. also handle pianos and player-pianos with much success.

ANALYZING INITIATIVE.

Initiative consists of doing on the spot without being told and without complaining what the other fellow never thought of doing—and didn't do when he was told.

HEAVY TRADE IN INDIANAPOLIS.

Christmas Business Surpasses All Previous Records—Stores Handle Profitable Saturday Night Trade—Columbia Co. Stock Cleaned Out Temporarily—News of the Month.

(Special to The Talking Machine World.)

INDIANAPOLIS, IND., January 7.—Christmas trade in the talking machine business here exceeded all expectations of the dealers, who assert that the holiday trade of 1913 was nearly twice as heavy as the Christmas trade of 1912. Talking machines and records were scarce articles around the stores when the doors closed on Christmas Eve.

The Columbia Graphophone Co.'s local branch thought for a while that a number of customers were to be disappointed, but at the last moment the express company came along with twenty-eight extra machines and thus saved the day.

The Stewart Talking Machine Co., Victor distributors in Indiana, had the best Christmas trade in the history of the house. W. S. Barringer, manager of the company, worked day and night in handling the large volume of business. The company's warerooms were emptied by the onslaught of Victor buyers.

The talking machine department of the Aeolian Co.'s branch also had a huge Christmas trade. Victor machines by the carload were shipped in for the Aeolian Co.

The Kipp-Link Co., the energetic distributors for the Edison machines, also experienced gratifying sales, especially of the new Edison disc machines and records.

Most of the stores are still closing at 6 o'clock on Saturday evenings, but the Columbia Graphophone Co. and the Kipp-Link Co. say the public just won't let them close up before 9 p. m. Saturday. Apparently, there is a large class of talking machine owners who like to come downtown Saturday night and buy records for the next week. The volume of business done by the talking machine stores which keep open is surprising. The managers of the stores would prefer to close up, arguing that the stores would get the business anyway, but the machine owners demand service on Saturday night.

Records are scarce in the Columbia Graphophone Co.'s store, and the getting of more records is the problem which is bothering the management. While the writer stood in the store Saturday afternoon the salesman had to say again and again, "We're sorry, but we are out of that number." The popular records simply can't be kept in stock at all times. The patrons of the store, however, appeared to realize that the store was not to blame, and would promise to return in a few days when a new shipment would arrive. "My Skylark Love," by Denni; "Marriage Market," by Jacob; "Mad Scene from Lucia, and Caprice Viennois, by Ysaye, are among the records which are hard to keep in stock.

Advertising is nearly fool-proof. No persistent advertising of an article of merit has ever failed in the United States.

YOUR CHRISTMAS SALES

were, to a large extent, made up of the smaller machines.

FOLLOW THESE SALES UP and get *all* of the profit that a machine sale should earn by selling not only a good supply of records, *but also*

A Good Cabinet To Keep Them In!

Here is a cabinet-table that just hits the mark.

The top is of solid mahogany or quarter-sawn white oak. Sides of select veneer and corner columns of one solid piece. Fifty-two compartments lined with green felt accommodate either 10 or 12-inch records, and the spacious shelf below can be used for record albums or player rolls. There is also a 4-pocket needle holder and a simple and accurate index.

We have several different styles of cabinets matching in design the Victor IX and the Columbia "Favorite," and also cabinets to go with No. 60 and No. 80 Edison disc machines.

Send for our catalog. It tells everything about our entire line.

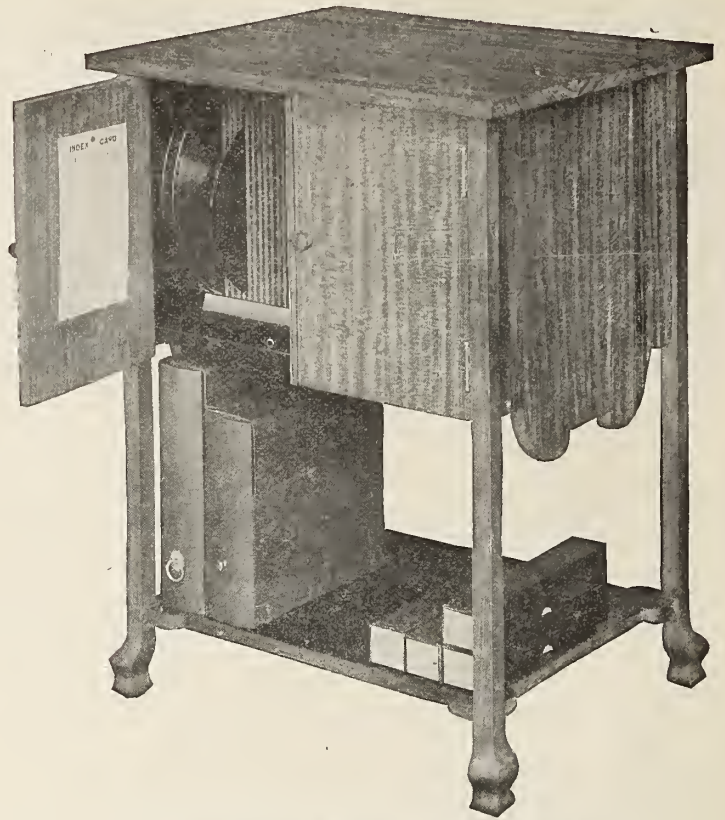

NO. 103—SIZE 33" HIGH. TOP 24 1/4 x 20 1/4"
Will hold any make of Columbia, Victor or Edison Disc Machine

SALTER MFG. CO.

Makers of Salter's Patent
Felt-lined Shelf Cabinets

337-43 N. OAKLEY BOULEVARD
CHICAGO

BEST MONTH IN TWENTY-TWO YEARS

Says Manager Dennison of Baltimore Branch of Columbia Graphophone Co. When Talking About Business for December—His Statement Coincides with the Views of the Leading Talking Machine Men in That City.

(Special to The Talking Machine World.)

BALTIMORE, Md., January 10.—"December is the best month we have had for twenty-two years." In those words which appear on a little blackboard beside the desk of Manager F. A. Dennison, of the local branch of the Columbia Graphophone Co., tell very plainly just what happened in a business way at this store during the days preceding the holidays. Manager Dennison keeps posted the business results right along on this board, and when these words appeared, the sales force felt very jubilant. This statement means a great deal for statistics show that the month of December of every year has been the banner month, while it so happened during several months of the year just closed that the figures even surpassed those for December, 1912. Mr. Dennison is not letting a matter of this kind bother him, however, for he is keeping right after the buyers, and declares that he is going to make 1914 go ahead of everything else.

With regard to the Victor line, Manager W. C. Roberts, of E. F. Droop & Sons Co., makes very elaborate reports. These instruments proved great sellers during the holidays, while the run on the latest records was extremely heavy. Figures at this store show the December business to have passed the sales for any previous month and this is going some, for the reports right along have been of the most encouraging character. This firm has put in two handsome soundproof rooms which have added to the attraction of the store and enabled the firm to better handle the customers.

The Peabody Piano Co. is also making rapid strides with the Columbia line. The firm has been in the talking machine business a comparatively short while, but they are going forward with a rush. They had a big December showing.

The Sanders & Stayman Co., Inc., also had a fine showing with the Victor and Columbia lines which they handle.

Hammann & Levin have put in two new soundproof booths for the benefit of customers for Victor talking machines which they handle.

THE FIBRE NEEDLE MASTERPHONE.

Latest Improvement Introduced by the Masterphone Corporation Is a Device for the Use of the Fibre Needle Which Is Highly Spoken of by Those Who Have Had the Privilege of Hearing It—Now Ready for the Market.

"We sold over 5,000 Masterphones within two months after it was introduced to the trade," states Matthew B. Claussen, president of the Masterphone Corporation, 187 Broadway, New York, manufacturers of the Masterphone, the popular clarifier for talking machines. "I am pleased to say that our device was a pronounced success from the very first announcement we made to the talking machine dealers throughout the country, as evidenced by the fact that we have on our books at the present time, the names of 500 aggressive dealers handling the Masterphone, with our clientele increasing every day.

"From the standpoint of the consumer, the Masterphone has evidently filled a long-felt want, as we have in our files nearly a thousand unsolicited testimonials from talking machine owners relative to the perfect satisfaction that our device is giving them, and the enjoyment they are deriving from its use.

"The emphatic success of our original Masterphone has prompted us to perfect another device which will be designated as the fibre-needle Masterphone, utilizing, as its name implies, a fibre needle, instead of a steel one. This latest Masterphone is now perfected, and we are preparing to fill the orders of a long list of dealers who have been awaiting the introduction of a fibre-needle clarifier.

"Our fibre-needle Masterphone represents a perfected clarifier that in our opinion and in the

opinions of a number of operatic artists who have heard it demonstrated, is the greatest aid to the proper enjoyment of a talking machine record that has ever been announced. We have demonstrated our fibre-needle device before several operatic artists now appearing in New York, who were enthusiastic over the clear and natural sound of their own selections.

"The basic principle of the fibre-needle Masterphone is the same as the original device with certain necessary changes. It consists of a triangular ball-socket arrangement in the Masterphone disc which corresponds of course with the shape of the needle employed, the point of the needle going through, and extending about a quarter of an inch. The volume of the fibre-needle is doubled by the use of the Masterphone, the sound is accurate, clear and distinct, and through the use of the Masterphone disc, each word is reproduced clear and true without the slightest sound of after-tone, and with the volume equal to that of a medium steel needle. The fibre needle, of course, practically has no wear on the record.

"The retail selling price of the fibre-needle Masterphone, which costs considerably more to make than the original one, will be \$1.50, with a liberal discount to the trade."

TAFT'S MESSAGE TO INDIANS.

Dr. Joseph K. Dixon, leader of the Rodman Wanamaker Expedition to the North American Indians, returned recently to New York in his private car over the Pennsylvania Railroad after a 25,000-mile tour of the United States, during which he visited every Indian reservation in the country.

Dr. Dixon took on the trip the flag which President Taft raised over the Indian Memorial at Fort Wadsworth last May, and a phonographic record of the President's speech on the American Indian. At each of the reservations, 185 in all, Dr. Dixon raised the flag and produced President Taft's speech.

Dr. Dixon completed the circle by going to Fort Wadsworth and replacing the flag over the Indian Memorial.

MEDIUM PRICED MACHINES IN DEMAND IN NEW YORK.

But Despite the Lessening Demand for Higher Priced Models the Sales Average for 1913 Was the Best in the History of the Trade—Dance Craze Boosts Record Sales Materially—What Prominent Jobbers and Dealers Report—News of the Month.

With manufacturers, distributors and dealers unanimous in declaring that 1913 was the very best year the talking machine industry has ever enjoyed, and the recent Christmas trade equally as good, if not better, than that of 1912, there is every reason for the members of the New York trade to feel well satisfied with the results of this year's work, and optimistic in their predictions for the future.

Although the year as a whole closed in a most satisfactory manner, there is no doubt but that Christmas trade with some of the dealers was not quite up to expectations. The leading members of the local trade ascribe this slight setback to unsettled political and financial conditions, which were country wide.

Probably one of the most noteworthy features of the past year's trade was the tendency of the local buying public to confine their purchases to the machines retailing at \$150 and less, rather than the \$200 machines which were so popular during the Christmas trade of former years. The machines of all makes selling at \$75 and \$100 were easily the most popular in the entire catalog with the local trade during the past year, although many members of the trade are emphatic in stating that this class of trade is equally as satisfactory as the \$200 class, the larger number of popular-priced machine sales producing an increased number of record purchasers for the future.

Few members of the local trade have attempted to ascribe any specific reason for the comparative neglect of the \$200 machine the past season, attributing it chiefly to the tightness of the money market, which is particularly noticeable in the East, where the stock markets are located. Other dealers have asserted, on the other hand, that the manufacturers have presented such excellent value in their \$75 and \$100 machines that the prospective purchasers refuse to be convinced of the superiority of the higher priced types. At any rate, this condition is not the cause of any complaint, but rather of conjecture on the part of the dealers as to the exact reasons for the public's choice.

Dance Craze Helps Record Sales.

January and February are the acknowledged "record" months of the year, as more records are usually sold during this period than during any other three months. The first half of this month has started off with a rush, the demand in many instances swamping the dealers, who were not prepared for such an insistent call for certain types of records.

The present dance craze is undoubtedly acting as an impetus to one of the greatest sales of records that the trade has ever experienced. This demand for dance records is stretching out to all parts of the country, although it is more pronounced in the East at the present time than in any other section. The popularity of the dance record has been responsible for the sale of many machines, as numerous dance enthusiasts who have learned that they can enjoy the one-step, tango, hesitation and similar records in the comfort and convenience of their own homes have become impressed with the desirability of owning a talking machine in order that they might hear the records. In one prominent talking machine store on Fifth avenue the call for dance records has reached a stage where it is out of the question to keep them in the regular racks, as the salespeople would be obliged to waste considerable time in frequently going over to the racks and taking out the desired dance records for the waiting customers. Instead of the racks, boxes of twenty-five of each of the popular dance records are placed on the floor, where they can be instantly accessible and easily handled.

High-Class Records Also Favored.

Although the dance record demand is the most predominant feature in the local trade, it is not to be supposed that grand opera and instrumental records are not in demand by talking machine owners.

On the contrary, this type of record is at present experiencing its best season. The success of the opera season, which is more impressive this year than ever before, and the large number of recitals and concerts by famous artists that have been presented during the past few weeks, have all aided the sale of the more expensive records, and this class of record is certain to secure its share of the record business during the next few months.

Gain of 48 Per Cent. Over 1912.

"We have just closed the very best year in our history," stated R. F. Bolton, manager of the Columbia Graphophone Co.'s store, 89 Chambers street. "Our exact gain over 1912 is 48 per cent., which we naturally consider very good in view of the shortage of certain popular types of machines and the generally unsettled financial conditions. Our dealers generally report a very good business during 1913, particularly in the popular-priced machines and Columbia records. Our cash collections this year were better than last year, making an even higher percentage than heretofore, notwithstanding the increased volume of business. Our plans for the coming year include the extending of the heartiest co-operation to our many dealers, all of whom, we are certain, will find 1914 their banner year."

Increase of 100 Per Cent., Says V. W. Moody.

"Victor record business last month was exactly 100 per cent. better than that of December, 1912, which was a record breaker," was the surprising statement of V. W. Moody, sales manager of the New York Talking Machine Co., 81 Chambers street, the prominent Victor distributor. "This gain would have been even larger if we had not been handicapped by the factory's shortage on certain popular records. Our business as a whole last year exceeded by far all our expectations, and, although we have not yet completed our official figures for the year, we know that 1913 was the best year in our history, and the gain we registered over 1912 a splendid one. We ascribe our splendid year to the high quality of Victor products, the consistent advertising used by the Victor Talking Machine Co. and the co-operation we are extending to our dealers. We are offering our dealers real service, not merely half-hearted service, and the letters of appreciation and tribute that we received from our trade the week after Christmas were concrete evidence of the value of our methods and selling plans."

Extent of Edison Disc Business Surprises.

Edison disc business the past month has been one of the surprising events in the trade, thanks to the national magazine and newspaper advertising of Thomas A. Edison, Inc., on behalf of the Edison disc product. The following statement by Ashley B. Cohn, of Hardman, Peck & Co., the prominent Fifth avenue piano house which recently closed arrangements to handle the Edison disc line, is indicative of the general Edison business on the new product: "Although our Edison disc department has been open but a few weeks, and our furnishings, booths, etc., completed for only a fortnight, we have closed an Edison disc business that is really amazing. At the present time we have eight demonstration rooms, and it is a tribute to the numerous qualities of the Edison disc product that these rooms are crowded day after day, with patrons waiting to enter them." On the Saturday before Christmas several officials of the company, two wholesale piano travelers, two retail piano men and the regular Edison disc sales staff were in attendance at the Hardman, Peck Edison disc warerooms.

Blackman Says Best Year in History.

"1913 was generally satisfactory," stated J. Newcomb Blackman, president of the Blackman Talking Machine Co., 97 Chambers street, New York, Victor and Edison distributor. "We closed the best year in our history, and although there was a

shortage in the more popular-priced machines, our dealers who had placed their orders earlier in the season and who had co-operated with us in our efforts during the year secured practically everything they ordered. We make it a point to co-operate with our dealers throughout the year, and the satisfactory business reported by our dealers is very encouraging."

Manager Cleveland Enthusiastic.

The Columbia Graphophone Co.'s store on Twenty-third street is experiencing a very heavy trade in Columbia records that gives evidence of the fast growing popularity of this important division of the Columbia business. The dance craze is booming the sale of Columbia dance records, and Manager Cleveland is enthusiastic in predicting for 1914 the biggest Columbia record year his store has ever enjoyed. The Christmas trade at this Columbia stronghold was ahead of expectations, the many new types of Columbia machines being in heavy demand.

Tower Co. Reports Edison Popularity.

"Our Edison disc business is very satisfactory," states Manager Parkhurst, of the Edison disc and cylinder department of the Tower Manufacturing and Novelty Co., 326 Broadway, one of the first Edison disc agencies in the country. "Our phonographs and records are selling fast, and with the steady advertising that Thomas A. Edison, Inc., is doing, there is no doubt but that the Edison disc products will secure during 1914 a still firmer grip on the public than they now have."

"Best Year We Ever Closed" Says Landay.

"The best year we ever closed," states Max Landay, of Landay Bros., the prominent Victor distributors, with four retail stores. "You can say for us that Landay Bros. go on record as predicting for 1914 a still better year than 1913, with each succeeding year in the future better than the preceding one. Victor quality of product and Victor advertising form a combination that cannot be equalled."

Optimistic Reports from Others.

Optimistic reports of 1913 business and encouraging statements for 1914 were received by THE TALKING MACHINE WORLD's representative from the following: Bremner Talking Machine Co. (Victor); F. G. Smith, Brooklyn, Newark and New York (Columbia); Cort Sales Co. (Edison disc, Victor and Columbia); Silas E. Pearsall Co. (Victor); Pease Piano Co. (Victor and Columbia); Benjamin Switky (Victor); Paul Helfer (Edison disc); Michaels Bros. (Columbia).

TAKE ON COLUMBIA LINE.

Among the recent additions to the Columbia Graphophone Co.'s list of representatives in near-by territory are the Empire Phonograph Co., 246 Bowery, New York, and L. Ebenchick, Albany, N. Y. Both of these new accounts placed substantial initial orders.

Send for Samples

If you will write us, giving name of your jobber, we will send samples on approval.

"DUSTOFF" Record Cleaners

add life to records.
Keep the Tone
Pure and Clear.

They will get into the minute sound grooves of the record and thoroughly remove accumulated dust and dirt. For all makes of records.

REGULAR MODEL

A popular seller. Each dozen in counter display carton; retails for 15c.

DE LUXE MODEL

Beautifully made. Put up in handsome display cartons; retails for 50c.

DUSTOFFS BRING YOU GOOD PROFITS

Jobbers everywhere and Columbia distributors can supply you in Canada through Berliner Gram-o-Phone Co.

DO YOU WANT A
LIVE
MAILING LIST?
Write to-day for details of our new plan.
(Please mention jobber's name).

Minute Shine Co.

174 Minute Shine Bldg.
PROVIDENCE, R. I.,
U. S. A.



THE TRADE IN BOSTON AND NEW ENGLAND

JOHN H. WILSON, MANAGER, 324 WASHINGTON STREET, BOSTON, MASS.

(Special to The Talking Machine World.)

BOSTON, MASS., January 9.—December was a record breaker in point of business, and not a concern in the city dealing in talking machines, Victor, Edison or Columbia, that was not taxed to the limit as the eve of the Christmas season drew near. As one dealer put it, the growth of the talking machine proposition as seen in this single month's business is phenomenal when one compares the present-day situation with the time when some dealers, and not so many years ago, thought that the talking machine was only a hobby and its life was limited. Certainly times have changed, as this is to-day one of the most important industries. Everyone your correspondent has met is most enthusiastic over the prospects for the new year.

Death of Edwin R. Read.

The local talking machine men have lost a good friend in Edwin R. Read, who died on December 29 in Waltham. Mr. Read was a veteran in the business, a pioneer in the game, and, it is said, brought the first talking machine into this city. He was eighty-four years of age and was of the firm of Read & Read, whose last location has been in Boylston street. Mr. Read was uncle of Mark Read, of the Eastern Talking Machine Co., and had friends everywhere. The body was taken to Lewiston, Me., where the funeral was held a few days later. Among the floral offerings was a large wreath sent by the employes of the Eastern Co.

Current Plays Help Record Sales.

Business at the Eastern Talking Machine Co. has been right up to the capacity of the house, and from Manager Taft down everyone was kept on the jump. The last week was a record breaker. The past fortnight the windows of the Tremont street concern have been most artistically arranged. As Lina Abarbanell was playing next door at the Tremont Theater in "The Red Canary," one of the windows was filled with advertisements of her records and the choice numbers of the musical comedy. Now that Donald Brian is here at the Hollis Street Theater in "The Marriage Market," a window has featured that musical piece, which means that all the attractive numbers of "The Marriage Market" are to be had within. It's a forgetful moment when the enterprising staff of the Eastern overlooks a prominent musical comedy.

Nagel Didn't Get the Bearskin Rug.

Frederick Hager, of the Keenephone Co., was in town the other day calling on the trade, and he played a joke on Adolf Nagel, of the Boston Symphony Orchestra, which the boys of the Eastern Talking Machine Co. are enjoying. Meeting Nagel outside, Hager gave him an order for a bearskin rug which was at the Eastern Co.'s establishment, and which Hager said he wished to make him a present of. Nagel accordingly went to the Eastern, where he knows all the boys, and asked for the skin, which is used as a rug on the floor of the main office. It was some time before Nagel became convinced that the rug was the property of the Eastern Co. and that he had been made the victim of a joke.

Heavy Columbia Business Increase.

Manager Erisman, of the Columbia Graphophone Co., reports that December was the largest month he ever has known and was 100 per cent. better than December of the year before, which is going some. As an explanation of why the Boston office was able to do such a large business, it is stated that there is such co-operation among the staff and the organization is so perfect that it makes for business at the outset.

Selling Columbia Grands.

Manager Erisman disposed of a Columbia grand to James J. Phelan, of the banking house of Hornblower & Weeks, a few days before Christmas. Another to whom Mr. Erisman made a sale of one of the handsome grands was George W. Brown, vice-president of the United Shoe Machinery Co., who makes his home at the Hotel Touraine.

Extra Quarters Proved Useful.

George Lincoln Parker, of the Colonial Building, did a large business during the holidays, and he found the new apartment which he leased for those few weeks on the floor below of great use during the rush days. The room was handsomely furnished, and the finest of the Edison disc and Victor machines were constantly demonstrated. Mr. Parker hopes soon to be able to add to his suite, so that his enlarged quarters may be of a more permanent character, as his business is growing rapidly. The year just closed was the best twelve months Mr. Parker ever experienced.

Popular with the Business Men.

Harry Rosen, of School street, had a remarkably large holiday trade, and the fact that he

always keeps his establishment open late on Saturdays, when he has to hire extra help, makes his place very popular with downtown men. Mr. Rosen lately has taken on three additional clerks, William Thatcher, Arnold Zoobley and George Rosenblatt, all of them expert and competent men.

Resumed Street Car Traffic Helps Trade.

No sooner had the surface cars been put back on Boylston street on December 15, following the long period of subway construction, than the Victor business of the Henry F. Miller Co. immediately picked up, and from that time until Christmas Manager White and his staff were kept busy day and night. The business done during the last fortnight was such as to bring the sum total of the year's business up to a high figure.

Opera Stars Among the Visitors.

Madame D'Alvarez, the new mezzo soprano of the Boston Opera Company, is a frequent caller at the Columbia Graphophone Co.'s Tremont street quarters, and when not singing she has a merry time with a Columbia grand, which is one of the furnishings of her suite. Another visitor is Mardones, one of the basses of the company, who is an enthusiastic Columbia admirer. Whenever Alice Nielsen is in the city she never fails to pay a visit to the Columbia parlors.

Large Increase in Edison Business.

Manager Silliman, of the Pardee-Ellenberger Co., was more than satisfied over the year's results, and the distribution of Edison disc machines during the month of December was phenomenal. With two good catalogs, one devoted to machines and the other to disc records, the trade is pretty well supplied with informing matter, and those owning Edison outfits now have no difficulty in getting all the records they desire, thanks to this rapidly growing catalog. R. C. Peck, one of the traveling force of the Pardee-Ellenberger Co., is hustling through Vermont; Guy R. Coner is finding much business in territory not far removed from Boston, and L. H. Ripley is devoting his time to the cultivation of a local territory, and the harvest he is reaping is a rich one.

Victors for Ansonia, Conn., Schools.

Richard Tobin, the superintendent of schools of Ansonia, Conn., has been in correspondence with Manager Taft, of the Eastern Talking Machine Co., relative to the installation of Victor machines in the schools of his city; and the result has been that ten were recently expressed to that

**Are You Going
to Let Big Profits
Slip Away from You
During 1914?**

**Real Music
At Last**

The Pardee-Ellenberger Co., Inc.
BOSTON, MASS. NEW HAVEN, CONN.

Answer "No!" to that question, and ask us just how to make 1914 the most profitable year. You don't have to "sell" anything for this line of goods sells itself. All you have to do is to show us that your ability as a distributor can be created so that the new machines and records from the factories of Thos. A. Edison will be properly represented in your city.

Edison Disc Phonographs

are recognized as the greatest development of sound reproduction ever achieved in the world's history; so great is the demand for Edison machines and records that the factories are rushed to meet the orders, and Edison goods are recognized to-day as the FASTEST SELLING phonographs. No matter what line you are handling, ask to hear the New Edison. After you once hear it, you'll go after these big profits.

THE TRADE IN BOSTON AND NEW ENGLAND

JOHN H. WILSON, MANAGER, 324 WASHINGTON STREET, BOSTON, MASS.

city and are now playing an important part in the musical development of the public school children.

Manager Erisman's Clever Ad Stunt.

The R. H. White Co., of Boston, one of the largest of the department stores, did a big Columbia business during the holidays, and the publicity given the Grafonolas was due in no small measure to the clever advertising "stunt" which originated in the fertile brain of Manager Erisman, of the Columbia. Four good-looking young women were stationed about the store, each wearing a broad red sash with the word "Columbia" in large white letters. These sashes were draped across one shoulder so that the word Columbia was conspicuous across the breast. Where the two pieces of the sash met under the arm was the seal of the Columbia—two eighth notes—in blue and white. These girls distributed cards advertising the Columbia outfits and directing the possessors to the Grafonola parlors on the third floor of the establishment, "and secure full information relative to our special holiday terms." The scheme worked admirably and drew renewed attention to the Columbia proposition.

H. R. Skelton Visits Edison Factory.

H. R. Skelton, who has been spending several months in Chicago in the interest of the Thomas A. Edison, Inc., is back in Boston, and reports an active season, which resulted in wide publicity for the Edison disc proposition. Mr. Skelton got back in time to spend Christmas with his family in Roslindale, and then went over to the Edison laboratories at Orange, N. J., where he spent several days of the new year.

The Holiday Rush at Ditson's.

Henry A. Winkelman, with that perpetual smile that betokens complete accord with the whole world, found things pretty lively in his Victor department at the Oliver Ditson Co. during December. The year right through has been an eminently satisfactory one, and his large staff of clerks feel a bit relieved that the holiday rush is over. Manager Winkelman's right hand man, Otto Piesndel, has found a quiet corner for himself where he can attend to his official duties when not waiting on customers. That is to say, he is enjoying a "near-private" office close to Manager Winkelman's corner.

Greetings from Constantino.

Constantino, the former leading tenor of the Boston Opera Co., sent his friends in Boston Christmas greetings in the shape of postals with a photograph of himself and his signature. Several were received by those in the local talking machine business.

Elsie Janis to Make New Records.

Elsie Janis, one of the stars of "The Lady of the Slipper," playing at the Colonial, paid a visit with her manager to the Eastern Talking Machine Co. a few days ago and informed the house that she is about to make some new records for the Victor.

Edison Business Outfits in Demand.

The Office Specialty Co., of 220 Devonshire street, found things lively during the end of the year and they were able to make many sales of Edison disc outfits to a select class of patrons. The company's quarters are conveniently situated in the downtown section of the city.

Newspapermen Enjoy Victor Concert.

Manager Herbert L. Royer, of the Arch street Victor department of the M. Steinert & Sons Co., loaned a Victor outfit to the Newspaper Club on the occasion of its annual dinner at the Boston Yacht Club quarters in Atlantic avenue on the night of January 2. The Victor was a complete surprise, and no one knew of its presence until one of the members, called upon to sing "I Love a Lassie," asked to be excused. "Well, we'll have the song anyhow," called out the "manager" of

the show that followed the dinner and, giving the signal, the strains of the song were heard from the adjoining room. Thereafter a most enjoyable concert was given, Herbert Evans, of Manager Royer's staff, operating the machine to good purpose.

Does Some Important Work.

About the busiest man these days is "Captain" Ned Wilkinson, who is the man responsible for the safe departure of the Victor and Columbia machines from several of the large talking machine establishments. The Captain is on the job early and late and just at this time he and his many teamsters have about all they can do.

PLANS TO GO AFTER RECORD TRADE.

Special Demonstration Booth Installed in Store of Peck-Leach Furniture Co. to Take Care of Business—Furnishing Service.

(Special to The Talking Machine World.)

TAUNTON, MASS., January 8.—The Peck-Leach Furniture Co., of this city, has just installed a new and up-to-date soundproof demonstration booth in its Victor department for the convenience of its many patrons, who are constantly dropping in to get records. The manager of the talking machine department of this large establishment is William Howes, who, through keeping in close touch with such large centers as New York and Boston, is able to inject into his business all the latest innovations and customs of which the purchasing public gets the benefit.

In establishing this demonstration room Manager Howes, who will be pleasantly recalled as formerly in the talking machine business in Boston, states that it will obviate the necessity of sending out so many records on approval, which is unsatisfactory and is gradually being eliminated wherever possible. Mr. Howes now keeps constantly in stock a representative line of the best records to be found in the entire Victor catalog. An invitation extended to the public to inspect the improved Victor quarters has been taken advantage of by many people—many, in fact, who hitherto had placed their orders for records in either Boston or Providence.

MANY NEW DEALERS SIGNED

By J. W. Scott on His Recent Trip Through New England in Behalf of the Edison Disc—New Agents in Norwich and New London.

(Special to The Talking Machine World.)

BOSTON, MASS., January 9.—J. W. Scott, who has been traveling for the National Phonograph Co., and its successor, Thomas A. Edison, Inc., for the past thirteen years, most of the time in New England, is now demonstrating the new Edison disc phonograph in all the large cities in that section, and he has met with most flattering success wherever the new machines and records have been demonstrated.

Mr. Scott began his work on November 5 with a recital and demonstration at the Hotel Worthly in Springfield, Mass., during both afternoon and evening. The impression made with the latest Edison product was evident from the flattering notices appearing in the daily papers. At frequent intervals recitals and demonstrations were also given by Mr. Scott in other cities in New England, including Norwich and New London, Conn., in which cities Mr. Scott was successful in signing up as dealers the Porteous-Mitchell Co. in Norwich and the James Hislop Co. in New London, both of which concerns had never before handled musical goods of any kind. The recitals were always held in the leading hotels in the various cities and every effort was made to impress the visitors with the artistic rather than the commercial importance of the Edison disc phonograph and the new records. Every recital was duly announced by large advertisements in the daily papers, and in cases where an Edison disc dealer was already located in the city, as was the case with Otto Baab in Springfield, he also took the opportunity to advertise the new machines on his own account.

At the present time Mr. Scott is spending a few days at the Elton, Waterbury, Conn., and during the coming months plans to continue in an even more energetic manner the demonstration campaign that has proven so successful in the short space of two months.

W. H. BAGSHAW
ESTABLISHED 1870
Lowell, Mass., U.S.A.
WORLD'S LARGEST
MANUFACTURER OF
**TALKING MACHINE
NEEDLES**
OF ALL STYLES, SHAPES AND SIZES

DESIGNER AND
MAKER OF
**DUPLEXTONE
NEEDLES**
THE NEEDLE WITH TWO TONES
LOUD AND SOFT
WRITE FOR ILLUSTRATED BOOKLET

STANDARDIZING A SYSTEM OF TONE PRODUCTION.

The Efforts of Prof. Bertrand de Bernyz, President of the American Opera Society, in This Connection Are Interesting—His Visit to the Edison Laboratory and His Experiments with Records Are Most Valuable—Wins Edison's Support and Personal Approval.

That great and rapid strides have been and are being accomplished toward the establishing of a standard of tone production to be adopted throughout the entire world is evidenced by the fact that the man who is the strongest champion of this cause, Prof. Bertrand de Bernyz, president of the American Opera Society, has won the support and personal approval of Thomas A. Edison in his effort to standardize a system of tone production, after proving it to be the system for producing pure tones.

Mr. Edison grew so enthusiastic over this subject lying close to the heart of its great champion that he devoted all the choice portion of the day to this interview, keeping scores of waiting ones on the outside of his laboratories, while Prof. de Bernyz explained in minutiae the science of tone production and its applicability to the natural laws. He also made demonstrations on his own voice and the voice of a pupil, a tenor.

The contention of Prof. de Bernyz that a standard of tone production is not, as contended by other teachers, beyond the pale of possibility, is upheld by Mr. Edison.

Through the courtesy of Mr. Edison Prof. de Bernyz was permitted to hear artist after artist of world renown from the two huge phonographs in Mr. Edison's laboratories. The season's salary of these artists represents a fortune, and not one voice was perfectly pure or free from defects. These phonographs reproduce with unmistakable clearness the human voice, and in all there was easily discernible to those listening the interference with the tone production.

But Mr. Edison hears these voices through an instrument which acts upon the ear as does the microscope upon the eye, exaggerating the minutest detail, so that it is not possible to overlook same.

The fact that in listening with the natural ear to the reproduction of these illustrious artists various defects are detected without difficulty proves beyond all doubt that if artists were heard without scenery, orchestra, atmosphere, and the hypnotism of the crowd, and were entirely dependent upon their vocal effort for success, with no personal magnetism or gestures to aid them, many enjoying the applause of five continents to-day might be relegated to the catalog of failures.

Mr. Edison made exhibition of the imperfections of our leading vocalists and most celebrated singers, then heard with much gratification and deep satisfaction the succession of tones produced by Prof. de Bernyz, all of the same superior quality, regardless of where in the scale they were located, proving unquestionably the possibility of mastering a technique of tone production that enables the singer to produce one or hundreds of tones in precisely the same manner.

The fact that the registration of the voice on the phonograph record varies, or the same tone repeated makes a different line on the sensitized disc, demonstrates that the tones are produced in different manner. It is but logical that tones produced in like manner will record on the disc in the same manner.

It is also obvious that if, when Mr. Edison reads the record with his powerful microscope, he finds a high C, for instance, has been registered five times in as many different ways or lines on the disc, that the high C was produced in just so many different ways.

The use of the phonograph in teachers' studios has long been advocated by Prof. de Bernyz as an aid to the pupil. Mr. Edison agrees with Prof. de Bernyz that it is by this means that the pupil or artist may most readily determine his faults and overcome them, if he is properly instructed.

By invitation of Mr. Edison, Prof. de Bernyz will avail himself of an opportunity to demonstrate on the voices of numerous pupils that the production of pure tone is not accidental, but the result of mastering technique of a proper tone production.

In connection with the phonographs which Prof.

de Bernyz will install in his private laboratory, he will use an invention of his own, an apparatus used in acquiring breath control, and an aid to both teacher and pupil. Mr. Edison's invention has to do with the finished product; while that of Prof. de Bernyz has to do with the first principles and has to do with the producing—a complement to the inventor's much-loved instrument.

It is a source of much gratification to those who hope for a standard of tone production to learn that Mr. Edison, who has hitherto been interested solely in the results obtained and not in how to acquire the desired results, is now intensely interested in the tone production—interested to the extent that he gives hours of his invaluable time to learn of this new system discovered by Prof. de Bernyz, and of which he is the author and instructor says the Opera News.

The additional fact that Mr. Edison affixes the seal of his approval to the contentions of Prof. de Bernyz, declaring that pursuing his present policies the establishment of a standard of tone production is easily within sight causes the hope that "springs eternal" to leap to great heights in the hearts of those vitally interested in the American Opera Society. For the interest lying nearest their hearts is that of precluding the possibility of so much fraudulent practice among the unscrupulous, and thus preventing disappointment and misery, the inevitable consequence of pursuing wrong methods.

NO "CUT PRICE" FOR STAMPS.

And Yet Men May Be "Cut-Priced" for Commodities—Another Argument for the Fixed Re-sale Price—Uncle Sam as a Merchant.

Under the heading of "The Living Wage for the Dealer," the editor of American Paint and Oil Dealer advances a timely and interesting argument in support of the right of the manufacturer to maintain a fixed re-sale price on his trade-marked products. The editorial, in part, follows:

The Government recognizes and practically enforces the principle of the living wage among the great aggregations of capital that are being subjected to the processes of "regulation." It jealously watches over and intervenes or "mediates" between the railroad companies and their employees for the maintenance of the living wage, and while now becoming more alert and efficient in its

supervision of their financing, and its control of their rates, the principle of the living wage, extended to give capital its own fair return, over and above the cost of doing business, interest on bonds, betterments, depreciation, etc., is also recognized and established; and upon that basis the retail selling prices, the rates for service, are fixed by the Interstate Commerce Commission. But woe be, and is, unto the road that "cuts the price," by secret rebates or by open "ruinous competition." The Government even prohibits the sale of its postage stamps at "cut prices"—and they're not "returnable for, or without, any reason." An independent merchant is Uncle Sam.

But the small dealer, independent and practically unorganized, is not entitled to the living wage—at least that appears to be the belief of the newspapers and magazines, and the Government, and the public itself; a public that is generally fair-minded, and quick to resent any injustice, but a public that for years has been mis-educated on merchandising, the principles and ethics of buying and selling; though the merchandising community and its allies have undergone a process of education in recent years that has quickened all classes engaged in regular or so-called legitimate distribution with a broader intelligence and a keener conscience in their relations with each other and with the public.

The dealers, the jobbers and the manufacturers, in the reputable trade, believe in the living wage, for themselves and for each other, as well as for labor and capital in other fields. Their earnest study of cost accounting, their more general realization of the cost of doing business, and their application of this knowledge, have practically eliminated the ignorant or careless price cutter—the man who unwittingly undermined the living wage of his fellows and himself.

THOMAS A. EDISON'S DOUBLE.

The extraordinary resemblance of E. F. Manchester, Randolph, Vt., to Mr. Edison led the Edison representative to wonder if he has not interrupted a peculiar vacation. The illusion was heightened by the fact that Mr. Manchester is exceptionally deaf. However, he states that he finds this no handicap in his business.

COLUMBIA GRAND FOR CHOIR USE.

R. R. Souders, manager of the Columbia Graphophone Co., sent a new Columbia grand to the First Baptist Church Choir, Dallas, Texas, of which Will. A. Watkin is organist and director, for an evening recital. A nice letter was received from the secretary of the choir by Mr. Souders thanking him for this courtesy.

Record Service

IS WHAT YOU NOW NEED

Dealing with BUEHN assures you the best in service that can be had. Stocks of EDISON CYLINDER and VICTOR DISC RECORDS, both Domestic and Foreign, as complete as large orders and factory deliveries can make them.

Send your order for RECORDS to

LOUIS BUEHN - Philadelphia

and be convinced.



The profit on Columbia Grafonolas and Columbia Double-Disc Records is music enough for any dealer.



(Write for "Music Money," a book "full of meat" for those dealers interested in quick and frequent turnover of capital.)

Columbia Graphophone Company
Woolworth Building, New York

VICTORS FOR DALLAS SCHOOLS.

Board of Education of Dallas, Texas, Purchase Twenty-six Victor Talking Machines and Records to Be Divided Among the Different Schools of That City—Now Considered Indispensable for Educational Purposes.

The missionary work done by the Victor Talking Machine Co. in introducing the Victor into the public schools of the country began some time ago to produce that kind of automatic momentum which comes to all commercial enterprises when they are based on sound principles and systematically developed.

The Times-Herald, of Dallas, Tex., in its issue of December 9 published the following:

"Another item of the expenditure made by the board was the order for the purchase of twenty-six Victor talking machines, with records enough for use in the different schools where they will be used. The total price for these instruments will be between \$1,900 and \$2,000. These instruments and supplies will be used in the musical and athletic departments of the school system. The purchase of this equipment will be equally divided between the two agencies in Dallas, Sanger Bros. and Field-Lippman Piano Co. A. Harris & Co., another agent, is not qualified to compete for the business, as A. L. Kramer, president of the company, is a member of the board, one of the laws of which says that no member of the board shall figure in any financial transaction of the board."

There was a time when Victors were established in the schools by contributed funds. The condition is changing, and they are now being officially acquired along with other school supplies.

On November 28 the same paper published the illustration and comment which follow:



Taking Physical Exercise to Music by Victor Talking Machine.

"The above picture shows a class of small children from the Rusk School, who are taking the physical exercises which are now being given in the public schools of Dallas. Standing behind the children is Miss Bessie Keller, assistant super-

visor of the physical education department of the city schools. A demonstration of the work in this department is being shown this afternoon before visiting teachers. The program began at 1 o'clock in the auditorium of the Dallas High School, and is being witnessed by a large number of interested teachers and school officials from over the State. The program which has been arranged is being participated in by various schools and is as follows:

"Minuet, first grade, San Jacinto School, Miss Keller; Tantoli, second grade, Colonial Hill School, Miss Goslin; Swedish Gymnastics, third grade, Rusk School, Miss Wilson; Highland Schottische, second grade, Sam Houston Normal, Miss Hölder; Hopp Mos Annika, third grade, San Jacinto School, Miss Cochran; Thanksgiving, second grade, Stephen F. Austin School, Miss Tate."

The instruments secured by the school authorities, were in addition to others previously installed, and in the future there are to be two Victors in each of the schools of Dallas.

A REAL "RECORD" PROPOSAL.

Phonograph Worker's Note Brings It from Widower with 11 Children, but Too Late.

(Special to The Talking Machine World.)

WEST ORANGE, N. J., January 8.—A proposal of marriage from a widower with eleven children has been received by Miss Jessie Cosgrove, who was formerly employed by the Edison Phonograph Record Works here. A few years ago, for a joke, Miss Cosgrove wrote a note on a piece of paper which she inserted in a record of "Where the River Shannon Flows." There was a large demand for these records in Ireland, and yesterday Miss Cosgrove, who is soon to be married, received the proposal from one Dennis O'Finn, of Westmeath, Ireland.

In part the letter says: "In a talking machine record I found a note in which you say you are looking for a man. Being as I am a widower, I would like to say I wouldn't mind if you would come to this country so I could marry you. Although I am fifty-three years old now, my health is just as good as when I was twenty. I have a wooden leg, because I lost the real one in a steam road accident, but the artificial one

doesn't interfere with my walking or work.

"My good wife died from a fever more than twelve months ago, and, having pity on my eleven little ones, I thought to ask if you would become my wife so I may entrust their bringing up you."

TWO NEW EDISON ARTISTS

To Be Introduced in Edison New Amberol List for March Are Edmund A. Jahn, Bass Soloist, and Gustav F. Heim, Internationally Famous as a Trumpeter.

Two new artists will be introduced in the Edison new Amberol record list for March. The first is Edmund A. Jahn, who is recognized as one of New York's foremost church singers, being at present bass soloist at the St. Nicholas Collegiate Church. He also has an excellent reputation in the concert field, having appeared in various prominent festivals and concerts. Mr. Jahn will be



E. A. Jahn, Baritone. G. F. Heim, Trumpeter.

represented in the March list by PUNCHINELLO, one of Max Heinrich's famous songs, and he renders it in a masterly manner.

The second new artist represented in the Edison list for March is Gustav F. Heim, who ranks as one of the world's greatest trumpeters, having served with some of the leading military bands on the Continent. He came to St. Louis during the World's Fair, where he was engaged specially because of his skill as a trumpeter. He has been associated with the World's Fair Orchestra, which was conducted by some of the world's most eminent conductors. Mr. Heim later became connected with the Philadelphia Symphony Orchestra, and later was engaged as first trumpeter of the Boston Symphony Orchestra under Dr. Muck. Mr. Heim's superb playing is well displayed in the record which he has made for the March Blue Amberol list—"Inflammatus," from Rossini's "Stabat Mater," a wonderful record in many respects.

MOTORS FOR TALKING MACHINES.

Gebrüder Steidinger, St. Georgen, Black Forest, Germany, have made a hit with their new types of motors for talking machines. The device by means of which the spring casing of the Steidinger mechanism can be easily taken out is so efficient and yet so simple that even the most uninitiated can take out the casing from the mechanism, and put in a new spring without the slightest trouble. The high efficiency of Steidinger mechanism, which has been already recognized and appreciated in every country in the world, is further enhanced by this most excellent device.

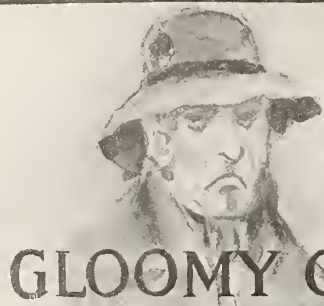

**OTHER
BUSINESS
1913**
GLOOMY GUS

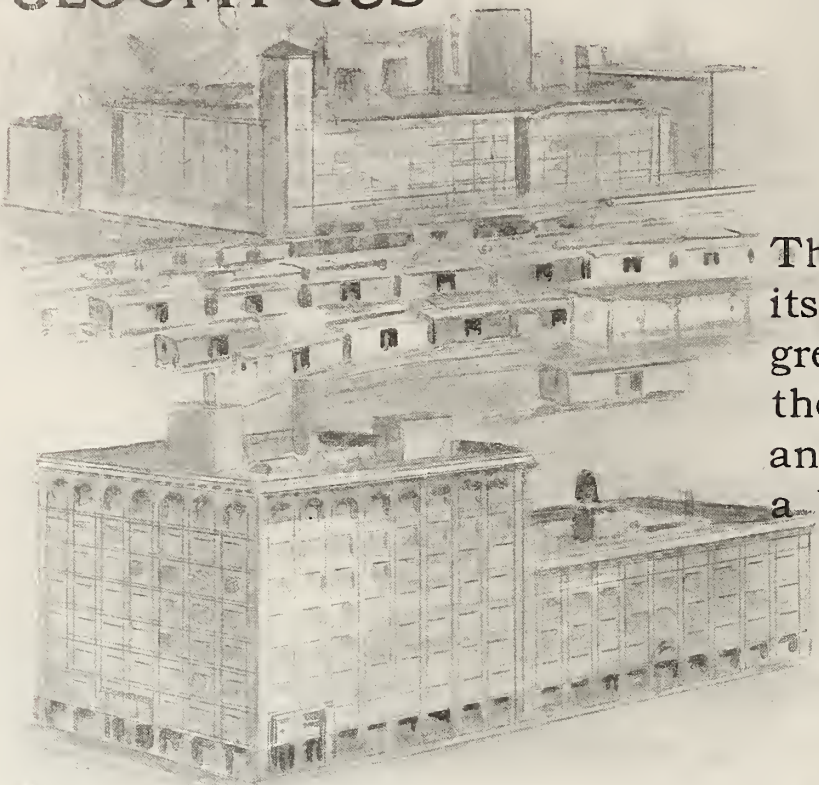

1913
Our Most Wonderful Year

Sunny Jim perched on our Banners in spite of Dull Gloom hovering over other lines of merchandise.

The Victor very nearly doubled its business last year—with this great impetus beyond you, with the financial horizon clearing and conditions pointing toward a boom year.

**What Can You
Expect of
1914?**

There was a shortage during the holidays caused by the enormous demand but *our service was excellent and was appreciated.*



New York Talking Machine Company
81 Chambers Street : : : : New York

TALKING MACHINE INTERESTS OPPOSE THE KAHN LAW.

Horace Pettit, of the Victor Talking Machine Co., Chief Spokesman at Washington for Talking Machine Interests in Opposition to Kahn Act Which Will Cause Great Confusion, Especially in Regard to Patents—The Present Status of the Oldfield Bill Set Forth.

(Special to The Talking Machine World.)

WASHINGTON, D. C., January 10.—Talking machine interests are very active in opposition to what is known as the Kahn Act. Indeed, the protest against this legislation which is now being registered at Washington by the talking machine trade, is second only to the fight which is being made against the Oldfield bill which aims to prevent the fixing of a resale price on talking machines, records and accessories.

Already the talking machine manufacturers are up and doing in their agitation against the Kahn Act, and the dealers are following suit as they come to realize that what menaces the interests of the manufacturers also menaces, indirectly, the retail end of the business. Horace Pettit, of the Victor Talking Machine Co., has thus far been the chief spokesman at Washington for the talking machine interests in their protest against the Kahn Act and he has made a strong case.

Talking machine interests might not be so adversely interested by the Kahn Act as by the Oldfield bill, but there is danger enough of damage. Furthermore the status of these two measures is very different. The Oldfield bill has been merely introduced in Congress. It has not as yet passed either house of Congress nor been signed by the President, so that it is far from being a law. The Kahn Act, on the other hand, is a law. It slipped through Congress last autumn and was signed by the President before the manufacturers of the country awoke to the injury it might do.

The Purpose of the Kahn Law.

The purpose of the Kahn law, as most of our readers are aware, is to protect foreign manufacturers who desire to exhibit their products at the San Francisco exposition. Some of these foreign exhibitors complained that when they exhibited at the St. Louis world's fair, their exclusive designs were pirated by unscrupulous American competitors. Hence they gave notice in advance that they would not exhibit at the Panama-Pacific Exposition unless assured that their models would be protected from reproduction.

To mollify the foreigners, Representative Kahn of California, introduced the bill which bears his name. In effect it enables any foreign exhibitor who has a foreign patent on a talking machine or other product, to secure, merely for the asking, American patent protection for his device, following the date on which it arrives for exhibition at San Francisco. There is a wide difference of opinion as to just what construction the courts would place on this law—in other words, how much the protection accorded foreigners is worth—but there is a widespread feeling among American manufacturers that at any rate it is liable to result in confusion and litigation. Worst of all is the fear that even if the law does not actually justify interference with American patented goods, it might be used by unscrupulous persons to annoy, by a system savoring of blackmail, manufacturers and dealers who were not fully informed as to their rights.

Basic patents on some of the elementary features of sound-reproducing instruments having expired, there is no fear on the part of talking machine men that this new law will cause controversy regarding the talking machine in its fundamental form, so to speak. But there is grave fear that it will precipitate disputes as to the right to use some of the patented improvements which make the talking machine of to-day so distinctive.

That talking machine men have an opportunity to register protest now, even though the Kahn measure has become a law, is due to the fact that a bill to amend the Kahn Act by striking out the objectionable portions, has been introduced in the House of Representatives by Representative Bulkley—who will be remembered by talking machine interests for his opposition to the Oldfield bill last year. Hearings on this Bulkley bill are now in progress before the Patents Committee of the House of Representatives—that self-same body be-

fore which representatives of the Columbia, Edison and Victor companies appeared last winter to oppose the Oldfield bill.

Arguments of Horace Pettit.

The Victor representative, Mr. Pettit, when he appeared before the Patent Committee a few days ago to protest against the Kahn Act, said in part: "It seems to me that there is no question that there has been a mistake in passing the Kahn bill. The intention probably was good, but unfortunately the wording of the bill is such that great confusion is going to occur doubtless in its administration, especially in regard to patents for utilities.

"This bill is going to work, in my mind, a great hardship on many manufacturers. I represent talking machine manufacturers whose industries I think would be considerably affected. Talking machines may be imported. There are some of them patented abroad, under foreign patents, which could not, perhaps, be patented in this country. Those machines would come in here under the guise of a foreign patent and would be exhibited in the Panama Exposition and a certificate issued of three years' proprietorship. The result would be that we would perhaps be infringing, technically, some of those rights, which could never have been protected under the patent of the United States."

Then followed the following conversation between Mr. Pettit and Chairman Oldfield of the Patent Committee.

Representative Oldfield: "May I ask a question? I understand your position to be this: Take the talking machine companies, some of whom you represent here. They have their patents that have been granted abroad, and probably those patents have run for five or ten years."

Mr. Pettit: "Yes, sir."

Mr. Oldfield: "Now, then, if a foreign talking machine concern would send talking machines to the exposition grounds and they have a patent in their own country, do you think that your selling your patented machine in conflict with theirs after the exposition ended would put you in the position of infringing on their patent?"

Mr. Pettit: "I think that it would during a period of three years provided our machine contained some construction which they had patented abroad under right which they could not have gotten here."

Mr. Oldfield: "And you have a patent now?"

Mr. Pettit: "Yes, sir."

Mr. Oldfield: "These machines can not possibly come in for some months yet?"

Mr. Pettit: "No, sir."

Mr. Oldfield: "Do you think that your patent that is valid now could be an infringement on those patented machines that may come in for three and a half years?"

Mr. Pettit: "I am speaking of improvements and new constructions which we are constantly adding to the machines. The machine might embody some improvement that might come in as having been patented under a German patent which would never have been granted here."

Mr. Oldfield: "I can see where we might get into trouble writing patents on your machines that were taken out after their machines were shipped here."

Mr. Pettit: "It is quite possible, on the other hand, reading the Kahn Act as it stands, that, supposing we had had it before it came into this country, the proprietorship abroad in their foreign patent would warrant them in getting a certificate here, which, according to the Kahn Act, would preclude us, even though we might have manufactured it here before."

Representative Oglesby asked leave to put a question to the representative of the talking machine interests. Said he: "Suppose you were manufacturing a machine in which you were using an appliance which was not patentable here at all. It may have been patented heretofore, or the patent may have run out, or else it was nothing new. They might come in here with an appliance of that char-

acter and file a certificate and stop you from making a machine which you had previously been manufacturing?"

"Under the Kahn Act they could do so," was Mr. Pettit's rejoinder.

In concluding his remarks, the representative of the talking machine interests said: "It seems to me that this law is going to occasion great confusion and is going to be greatly to the detriment and prejudice of the American manufacturer."

Kahn Law Hurting Panama-Pacific Exposition.

It has lately developed that the situation precipitated by the passage of the Kahn Act is likely to have considerable influence upon talking machine exhibits at the Panama-Pacific Exposition. Many manufacturers in all lines are threatening to boycott the exposition unless the exposition officials consent to have the Kahn law amended. Some of the manufacturers simply wish to show their resentment. Others say that they are afraid to exhibit their goods at San Francisco lest the mere circumstance of their exhibition there serve to call to the attention of foreign exhibitors patented features, the right of possession of which might be made a subject of controversy.

Of course, the talking machine manufacturers have not given any intimation as to what policy they will pursue with regard to sending exhibits if the objectionable act is not amended, but the situation presented is certainly an interesting one, particularly in view of the announcement that a number of leading American piano manufacturers will (from entirely different motives) refrain from exhibiting at the San Francisco show.

It is significant that the present United States Commissioner of Patents is opposed to the Kahn Act as it stands. He spoke on the subject at the same session of the committee at which Mr. Pettit appeared, but he made it clear that he was opposing the Kahn Act because it would subject the Patent Office to unpopularity and injury, and not because he wanted to serve the manufacturers. On this score he remarked: "If I am right it is a matter that affects the business interests of the country at large and the business interests of the country can take care of themselves."

The Oldfield Bill Is Coming Up Again.

Of course this has nothing to do with the effort to amend the Kahn Act, but it is an interesting piece of news for talking machine dealers and manufacturers who had supposed, many of them, that the Oldfield bill was dead, due to opposition in the talking machine field and other lines.

Congressman Oldfield tells The Talking Machine World that he hopes to have his bill "reported out" by the Patent Committee by February 1, and inasmuch as Mr. Oldfield is chairman of the Patent Committee he presumably knows whereof he speaks. If the bill is reported favorably by the Patent Committee, as its author predicts, it will be, the measure will presumably come to a vote in the House of Representatives during the spring. An effort will also be made to have this measure voted in the Senate before Congress adjourns.

The Oldfield bill in so far as it affects the talking machine trade is just the same as it was a year or so ago when the talking machine companies began their great fight against it and enlisted all jobbers and local dealers in talking machines throughout the country to the extent of having them make protests to their respective Congressmen.

Speaking for the benefit of readers of The Talking Machine World, Mr. Oldfield said that he considered it likely that the bill would be changed or rewritten in some minor respects in committee during the next few weeks when the measure will be under consideration by the Patent Committee (which must send a report and recommendation with the completed bill to Congress), but he predicted very decisively that the bill as it comes to the House for a vote by that body will have no changes in that section which hits hardest the talking machine industry,—namely the section which provides that it shall not be possible to proceed for infringement of patent against a person who sells patented products, such as phonographs, talking machines, records or accessories at "cut prices" or at prices lower than have been fixed by the manufacturers.



The first sale of a Columbia Record is the beginning of a steady business—business you should get—and can get.



(Write for "Music Money," a book "full of meat" for those dealers interested in quick and frequent turnover of capital.)

Columbia Graphophone Company
Woolworth Building, New York

HIGHER PRICED MACHINES IN DEMAND IN ST. LOUIS.

Talking Machine Dealers Feature Machines Selling for \$50 and Up During the Holidays and Report Heavy Business—Some of the Concerns That Made Noteworthy Records During the Holidays and the Lines They Featured—New Dealers Enter Field.

(Special to The Talking Machine World.)

St. Louis, Mo., January 8.—Now for 1914. After closing books on the best year's business, the talking machine dealers are talking of doing more this year. The Christmas trade surprised everybody by the way it held up to a fast pace all through the season. When some unexpected but hoped for deliveries of machines arrived late in December it was thought that every dealer would be able to take care of all of his trade, but Victor X's were short of the demand and country dealers were clamoring for more VIII's and VI's. XVI's also were short.

The Edison stock of machines got very low and some quick shipments were made from the factory to fill late orders. The Edison trade was harder hit by record scarcity than by that of machines.

The city dealers report stocks low after the flurry and reports that are reaching the jobbers indicate a fine volume of business may be expected this month and next, because of low stocks in the country.

The St. Louis trade was chiefly for high priced machines and no downtown dealer made any particular showing of small instruments. Only machines for \$50 and up were in demand, according to sales managers. Jobbers report a heavy shipment of smaller machines for out-of-town use. The department stores and some of the residence district dealers moved a fair number of the very cheap machines, the purchasers usually explaining that they were for the nursery.

Koerber-Brenner Music Co., Victor jobbers, has erected a sound-proof booth at its warerooms as a part of its display of stock for sale. That is, the booths are for sale, rather than demonstration purposes.

The Thiebes Piano Co. occupies the unique position (in St. Louis) of selling both the Edison and Victor machines. In the holiday advertising Manager Robinson placed these machines on par, and rather urged all customers to hear both and then decide. He says there was about an even break and that the double presentation kept attention centered on the higher-value machines.

W. H. Twheatt, recently of the Scruggs, Vandervoort & Barney department, has joined the Thiebes talking machine sales staff.

Harry Levy, talking machine manager at Aeolian Hall, says the new year finds stock in excellent shape for the onward movement of business. "I believe there is a disposition," he said, "to prepare for a let-up in certain quarters, but that does not appear to have reached the talking machine trade. The only dissatisfied dealers I have found assign absolutely local reasons. Collections are in good shape. The Christmas trade moved off nicely with our retail department and with our dealers. In our jobbing department we did some eleventh-hour shifting and I think all of our customers were taken care of. There was a shortage of some ma-

chines, the \$75 model, but we and the dealers realized that in time to turn enough of this trade to the \$100 styles to cover on that. I think generally the last Christmas goes onto the record as a capacity sale and the outlook is optimistic."

W. S. Fulton, who has been assigned to Missouri by the Victor factory, was in St. Louis the first of the year getting acquainted with jobbers and local dealers.

The department stores report excellent business for December. Any person who looks in at the Famous & Barr department occasionally realizes the truth of Manager Ligon's statement that his holiday business was limited only by his capacity for handling it. Despite the fact that his space was doubled before the holidays, and that he invaded a part of the piano department floor space, he was unable to handle all of the customers and had to be content with what he got hold of. This department has not indulged in the practice of other department stores, of placing machines on thirty days' free trial, and a sale is closed when the machine is sent out.

The Vandervoort Salon Victrola department is credited with doing an exceedingly heavy December business, and they talk figures there that are astonishing and minimize the effect of returns on the free trial offer. Manager Seegar's department is the handsomest in the city, and the moonlight rooms and easy chairs are a very decided attraction to luxury loving people, who also buy records.

Manager Robinson's best proof of prosperity at the Stix, Baer & Fuller department store is the added space that is given him with regularity and his increased facilities for serving his public.

C. W. Smith, manager of the F. G. Smith Piano Co.'s Columbia department, is planning to resume his concert program. He is well pleased with his first holiday outing in St. Louis.

At the Columbia warerooms there is a general spirit of good feeling over the holiday trade and everybody is boosting the works of the sales forces, both retail and jobbing.

Retail Sales Manager Duffy says, "Our low-price sales this year were about equal to the high-price sales of three years ago. There has been a consistent improved demand for the better models, and this year we have been getting excellent results from the table models. They were a little slow in catching on here, but they are going all right now and the buyers are invariably pleased."

General Manager Reid reported the country trade in excellent shape, collections good and prospects bright.

The Columbia has attracted considerable attention by some window displays that are out of the ordinary in St. Louis. One of them was piles of records, with a general placard, "An evening's entertainment." The various piles were labeled opera, tango dance, popular, vaudeville, etc. The prices ranged from \$5 up, and for Christmas week the

window was artistically trimmed with dolls. Mr. Duffy said that this window had been a producer to the extent of selling a good many of the lists just as presented, and bringing many inquiries from persons who filed lists of what they already possessed.

Some trade interest centers in the Columbia now because the lease on the present warerooms expires this spring and it is generally understood that the new terms offered by the agents are not to the liking of tenants. At least all the other tenants of stores in this block have moved when time came to sign new leases. Mr. Reid said that he had not yet found a new home, but added, "it is getting about time." It is known that Mr. Reid has been looking about.

The Silverstone Music Co.'s warerooms are to become known as "The Edison Shop," and all late advertising is bringing this phrase into the signature. The show window sign is being changed and the lettering appears on the demonstration booths. "The Edison disc has demonstrated to me," says President Silverstone, of the company, "that it is a splendid article of commerce to tie to, and I am going to impress upon the public that my large store is distinctly an Edison institution. I have no idea of putting in other talking machines, and am going to make what prestige of this I can.

"The jobbing business is developing in a way that indicates that its demands in the future will be heavy. New firms are being added daily almost and their business is growing to such an extent that we must expand constantly to handle it. The La Mothe Piano Co., in the residence district of North St. Louis, sold fifteen Edison machines at \$200 each and up during December. One of these machines was the \$375 type. This is an indication of what our retailers are doing to force us to expand the talking machine department."

Mr. Silverstone, as soon as the Christmas rush was past, called in carpenters and others to arrange for necessary changes. The dictating machine department was sent from the first to the second floor, and two new booths ordered for the first floor. The five main floor rooms are primarily record demonstration rooms, and he also uses a concert machine stationed in the corridor. The machines sales booth are on the second floor, and to meet the demand for space, machines have been paired with player-pianos in all of what were built for player demonstration rooms.

Some of the new dealers on the Edison list are: Henry Meyer, of Carlinville, Ill.; R. D. Wall, Mexico, Mo.; Humphrey Drug Co., Vandalia, Ill.

The Columbia Graphophone Co. closed arrangements recently with the prominent piano house of Otto Wissner, whereby this concern will install a Columbia department in its Jersey City store. Otto Wissner has already established the Columbia line in its Thirty-fourth street store in New York, and is achieving marked success with the Columbia products.

Another new Columbia account opened in nearby territory is Jacob Sheiman, 390 Grand street, Brooklyn, who closed negotiations recently for a complete line of Columbia products. He is enthusiastic over the prospects for business.

Mid-Winter Meeting of Talking Machine Jobbers' Association

The annual mid-winter meeting of the executive committee of the National Association of Talking Machine Jobbers, will be held at the Bellevue-Stratford Hotel, Philadelphia, Pa., on February 15, at which time the various officers and the members of the committee will consider a number of matters of general importance to the trade that have come up since the last meeting of the committee in

Following the meeting, it is the intention of the committee members to spend a day at the factory of the Victor Talking Machine Co., in Camden, where they will consult with the officers of the Victor Co., on various topics of more or less importance and will make a tour of inspection of the plant to gain an idea of the increased facilities for turning out machines and records.

serve to attract all those distributors who have the future progress of the trade at heart, and their efforts are meeting with success.

The accompanying excellent photograph shows the executive committee in a most interesting and effective grouping, and was taken at the recent meeting in Chicago, when every member of the committee was in attendance. In the lower row



Officers National Association of Talking Machine Jobbers.

First Row, Left to Right—W. H. Reynolds, Treasurer; Geo. E. Mickel, Vice-President; J. C. Roush, President; Perry B. Whitsit, Secretary; James F. Bowers, Executive Committee. Second Row, Left to Right—R. H. Morris, O. K. Houck, T. H. Towell, E. C. Rauth, also Members of the Executive Committee.

Chicago. All jobbers who are members of the association, whether officers or not, are invited to attend the meeting.

An important feature of the meeting will be the making of preliminary plans for the annual convention, which will probably be held in Atlantic City in July, and which, it is promised, will be one of the liveliest conventions ever held by the association, both from business and social viewpoints.

The present executive committee of the National Association of Talking Machine Jobbers is made up of men prominent throughout the trade and, who have taken an active interest in association work since it was first organized. They have, under the administration of President J. C. Roush, planned to increase the importance of the association as a factor in the trade, and to develop the association work in such a manner that it will

seated, are, from left to right: W. H. Reynolds, Mobile, Ala., treasurer; George E. Mickel, Omaha, Neb., vice-president; J. C. Roush, Pittsburgh, president; Perry B. Whitsit, Columbus, O.; secretary, and James F. Bowers, Chicago, committee member. From left to right, standing, are: R. H. Morris, Brooklyn, N. Y.; O. K. Houck, Memphis, Tenn.; T. H. Towell, Cleveland, O., and E. C. Rauth, St. Louis, executive committee members.

A NEW TALKING COMBINATION.

Dictagraph, of Detective Fame, Hitched to Talking Machine for Purpose of Recording Sermon at a Distance—Other Experiments.

Thus far the dictagraph has been employed mainly by detectives in showing up graft and political conspiracies, but a much wider use for it was demonstrated recently in a series of experiments by the inventor, K. M. Turner, at the Broadway Tabernacle, Broadway and Fifty-sixth street, New York, that the little instruments can be made valuable in recording and transmitting sounds from church services and public meetings. Hooking up one of his dictagraphs to acousticons, talking machines and telephones, Mr. Turner recorded and multiplied every sound at the services so that they were heard in a number of places at once.

The dictagraph was fastened in the pulpit of the church before the morning service began. Wires were rigged up to connect it with several acousticons in other parts of the assembly room, so that worshippers, however distant from the pulpit or defective of hearing, could follow the services. Other connections were made with the offices in the rear of the church. In one of the offices dictaphone transmitters were connected with three talking machines, and on their cylinders were recorded the sermon of the Rev. C. E. Jefferson the pastor. Mr. Jefferson speaks extempore in his pulpit, and wished to thus preserve his sermons for his own use and to duplicate them

on phonograph cylinders for distribution to "stay-at-homes," who, according to the last census, comprise two out of every three persons in the country.

In one of the guild rooms the sounds transmitted by the dictagraph were increased in volume by means of a large horn, so that a woman prominent in Mr. Jefferson's congregation, who could not sit through a service in church, was able to follow the worship and sermon at her home.

For all of these connections with the dictagraph Mr. Turner used a multiplier, which is also one of his inventions. Fastening this multiplier to a telephone instrument and fitting a dictaphone transmitter into it, Mr. Turner transmitted the sounds in the church to the homes of his family and several friends, and by long distance telephone to a newspaper office in Philadelphia. The organ music and congregational singing were heard distinctly in the telephones in this city and in Philadelphia. Mr. Jefferson's voice, during his sermon, it was said, sounded too loud, that all his words were not always audible on the telephones here. In Philadelphia Dr. Jefferson's voice was heard, but his words could not be understood. It was not possible to readjust the dictagraph in the pulpit during the service, but Mr. Turner believes that the softening of the voice under such circumstances will aid in having the words distinctly heard.

In speaking of the success of the experiment, Mr. Turner said, in part:

"I firmly believe it is only a short time ahead when the congregation sitting in the church or in-

dividuals sitting in their homes in San Francisco will be able, with the aid of the dictagraph and the telephone, to hear a sermon in New York, Philadelphia or Boston, with relatively the same ease and satisfaction as those who are actually present where the sermon is being delivered.

"It is now possible to throw the sermon from a dictagraph wire into a phonograph for permanent preservation. Many clergymen never prepare their sermons, and the best that they say under the inspiration of the moment is forever lost. The success attending our efforts in this direction on Sunday proves that we can now make a perfect record of these sermons while they are being delivered, at the same time that they are being sent over the telephone wire to distant points.

"From this record any number of copies desired can be made, and these copies sent broadcast for reproduction on family phonographs in the home, thus enabling many more thousands to hear the sermons than are able to crowd into the churches to hear them. A family living in the most remote part of the country can have at its hearthstone the best that has been spoken in this line. It can have a new sermon every Sunday by a different minister if it likes.

"Church organizations can arrange for the distribution of these records in the same manner as the books of a circulating library. Country churches and meeting houses without regular ministers, instead of waiting upon the itinerant circuit preacher, can provide their members with a sermon by the most distinguished pulpit orators of the great cities, via the new combination.

PAYEE CANNOT HOLD BANK.

Appellate Division Rules Against Brill Brothers in Unusual Case Which Is of Wide Interest to All Business Men—Negligence in Giving Prompt Notice of Dishonor Charged.

The payee of a protested note which is held by a bank cannot hold the bank liable for the default and release of an indorser if he himself has failed to forward to the indorser a notice of protest sent him by the bank which is in ignorance of the indorser's address. Enunciating this principle, which has hitherto not been defined, the Appellate Division has reversed a verdict of \$1,248.08 in favor of Brill Brothers against the Jefferson Bank. The court in a unanimous opinion, written by Justice Clarke, said:

"Brill Brothers were depositors in the Jefferson Bank and deposited therein two promissory notes for \$600 each, payable in four months, drawn by Henry C. Squires's son, G. Harry Squires, and indorsed Grace H. Squires, Brill Brothers. Mrs. Squires was the wife of G. Harry Squires. The notes were not paid when due and were protested. This action against the bank is based upon allegations of the complaint setting forth that the bank did not give due notice to Grace H. Squires.

"The bank's notary did not know the address of Mrs. Squires. He sent one notice to her, care of Henry Squire's Son, 30 Church street, the maker. It is conceded that this would not constitute due notice to her or reasonable diligence to satisfy the obligation of the bank. He also sent a notice addressed to Mrs. Squires, with the address blank, and a two-cent stamp attached thereto, inclosed in the envelope addressed to Brill Brothers, 47 Corlandt street, which contained the notice of protest addressed to them.

"Brill Brothers had the same time within which to give notice to the antecedent indorser that the holder had after the dishonor. They failed to forward the notice to their indorser. It is conceded that Mrs. Squires did not reside or have a place of business in the city of New York. The notary does not appear to have been negligent. He did what the law required; that is, he sent a copy of the notice addressed to Mrs. Squires to Brill Brothers. It seems to us that if they have been unable to collect from her by reason of negligence in notifying her of the dishonor it was their negligence and not that of the bank."

Honesty is still the best policy—yet there seems to be a lot of people who are opposed to playing "policy."

LOUIS BUEHN IS OPTIMISTIC

Regarding the General Outlook for 1914 and This Well-Known Philadelphia Talking Machine Jobber Tells Why—Closed an Excellent Year's Business in All Departments.

(Special to The Talking Machine World.)

PHILADELPHIA, PA., January 13.—Louis Buehn is enthusiastic over the year's work, and looks in the most encouraging way to the future, believing that the new currency bill is going to make money easy and he is of the opinion that the trade will this year enjoy even a greater era of prosperity than they did in 1913. "The past month," Mr. Buehn says, "has been the biggest we ever had. I have closed not only the biggest month I ever had, but the biggest year, and for the first time in several years I feel that I have given my customers perfect satisfaction." Mr. Buehn has only the highest praise for the manufacturers for the way in which they were able to supply the wholesalers and retailers, and he says that only in a very few of the most popular records did he find a shortage. He could have sold a few more records had he been able to secure them, but even this loss of trade was so small that it would be folly to complain. Their dictating machine business also took quite a satisfactory jump in December.

Mr. Buehn is most optimistic regarding every feature of his business, and he says that the only thing he can see wherein the dealers could be benefitted, would be the establishing of the rule for the charging of interest on deferred payments, and even that he believes will regulate itself. He says the factories cannot be asked or expected to remedy the condition, but he believes that there should be a difference between cash and instalment prices.

ANNOUNCE THEIR ENGAGEMENT.

The engagement was announced this week of John Child Ray, familiarly known as "Jack" Ray, assistant to Assistant General Manager H. L. Willson, of the Columbia Graphophone Co., to Miss Marguerite Latham, of 1820 Cortelyou road, Brooklyn, N. Y. No date has been set for the wedding.

John C. Ray, who is a son of Herbert B. Ray, assistant advertising manager of the Columbia Graphophone Co., has been connected with the Columbia Co. for a number of years, having held several positions at the company's factories at Bridgeport, Conn., prior to joining the New York executive offices. Miss Latham is one of

the most popular belles in the Flatbush section of Brooklyn, and the engagement was announced at a luncheon given at the Crescent Club, of which Miss Latham's father, Ellis C. Latham, is a prominent member.

URGES LEAGUE TO AID BUSINESS.

Col. Leland Would Restore Confidence in Financial World by Organizing Owners of Business Enterprises Into a National League for Mutual Protection.

A proposal to organize owners of business enterprises into a national business league for the purpose of resisting further attacks by radical politicians and for co-operating with the Government in measures which will restore confidence and help to bring about a return of general prosperity, has met the hearty approval of Col. Francis L. Leland, president of the New York County National Bank, who furthermore stands ready to give financial support towards the legitimate expenses to be incurred in forming such an organization.

"Several years ago," said Col. Leland in discussing the matter, "I made a suggestion of this kind, and I am glad to see it revived in a proposal now before the Chamber of Commerce executive committee looking towards an association of stockholders in railway and industrial corporations. I approve of this heartily, but I would go further and include in a national business league owners of all kinds of business concerns, including small factories, retail stores and shops.

"It should not be necessary to have politics enter into such an organization in any way. Its one and only aim should be to aid responsible Government officials in legislation for the public good and to compel radical politicians of all parties to stop their continual attacks on American enterprise.

"Long ago it became apparent that some such organization would have to be formed, and the time is now ripe for it. I confidently expect to see it undertaken in the near future, and when professional politicians feel the weight of its influence business will be permitted to go ahead honestly and fearlessly and this country will enter upon a period of prosperity such as it has never seen before.

"Trade is the most important thing in the United States. It is through employment in agriculture, manufacturing, mining and mercantile enterprises that our people earn their living. When reckless politicians looking for votes hammer away at large business concerns without reason they destroy confidence in those concerns. The disastrous effects are felt all down the line, for in this country at least we are all interdependent."

A MUCH APPRECIATED GIFT.

With its customary thoughtfulness for its clientele, the Blackman Talking Machine Co., 97 Chamber street, New York, the prominent Victor and Edison distributor, sent out this week a key chainette, which is designed for practical use. It has a number of distinctive features, including a double-swivel lock and a flexible chain. The key portion of the device can also be used as an emergency screw-driver or Presto gas tank key, thereby greatly enhancing its value. The most important feature of the Blackman gift is the fact that each key is numbered, and the corresponding number kept on file at the offices of the company, so that if any Blackman dealer loses his keys, they will be returned to the company, who will, in turn, notify the owner of the keys. Detailed pains were taken by the Blackman Talking Machine Co. to make this plan as practical as possible, and thus the key chainette represents a gift of practical and useful import.

"I knew a man," said a live-wire young minister, "who attributed much of his worldly success to a rule he'd made for himself. He saw how much time and how many opportunities went wrong, and how much money was wasted by indecisionists, as he called them. So he adopted for one of his mottoes: 'Guess quick and stick to it.'"

LONG CABINETS

Occupy a strong position.
They have many friends.

The Geo. A. Long Cabinet Co.

Write for Circulars of
RECORD CABINETS
and
PLAYER ROLL CABINETS

Address

Clement Beecroft, Sales Manager

309 W. Susquehanna Avenue
PHILADELPHIA, PA.

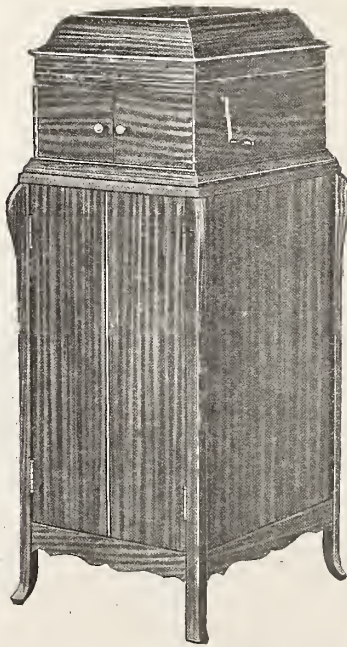

D 67

Mahogany, Golden Oak and W. O. Finished all around. Sliding Record Shelf. For IX Victrolas. Capacity, 19 1/2 in. Records.

PRESIDENT HUERTA PLEASSED

With the Record Made of One of His Recent Speeches—His Interesting and Appreciative Letter to the Columbia Graphophone Co.

In connection with the present political disturbances in Mexico, the Columbia Graphophone Co. is experiencing a heavy demand for the record made last summer by Gen. V. Huerta, the President of Mexico, around whom the disturbances are centering. This record in the Columbia library presents the speech made by Gen. Huerta, delivered before the National Representation.

It is somewhat unusual for a man of President Huerta's prominence to make records of his speeches, but the following letter, received some time since by the Columbia Graphophone Co., indicates the pleasure of President Huerta regarding his record:

"I take pleasure in sending you my most expressive thanks for your kind present of the record in which the speech which I delivered in the recent occasion before the National Representation is recorded. I congratulate you very cordially for the perfection and accuracy with which the said production is reproduced, and I take advantage of this opportunity to subscribe myself, yours very truly,

"(Signed) V. HUERTA."

EXPERIENCING A BIG DEMAND.

"Our new fibre-needle cutter, which we introduced to the trade a few weeks since, is proving considerably more popular than we had anticipated," states Thomas W. Kirkman, manager of the Standard Gramophone Appliance Co., 173 Lafayette street, New York. "Although we expected that our Standard cutter would be a success, we had not hoped for the very cordial reception the trade accorded it the first week it was introduced. There is undoubtedly a steadily growing field for fibre-needle cutters, as talking machine owners are beginning to appreciate more and more the musical value of the fibre needle. Our customers have informed us that they sold a vast amount of fibre needles the past year, considerably more than in 1912, and as every fibre needle purchaser is a cutter prospect, it is comparatively easy to figure out the possibilities in the fibre-needle cutter field."

DISCRIMINATING IN THEIR PURCHASES

Buyers of Talking Machine Record Albums Looking for Quality in Preference to Price, Says George Bates in an Interesting Chat.

"With dealers throughout the country reporting the best year in their history, which naturally signifies a vast number of new accounts, there should be a large increase in the demand this year for talking machine record albums," states George Bates, of the New York Post Card Album Co., 23 Lispenard street, New York. "Although the year just closed was the best we ever experienced, we are making preparations for a record-breaking year in 1914, in view of the new business that is on the books of the dealers.

"To my mind, the most important feature in the album business of the year just closed was the evident change on the part of the public in its attitude towards record albums of quality. Whereas a short while since, talking machine owners looked upon the record album as a slight incidental purchase, and bought any album offered them, they are now discriminating in their album purchases, and looking for quality in preference to price.

"A record album of inferior quality not only gives dissatisfaction to the customer regarding this single purchase, but causes him to lose confidence in the establishment where he bought it, which loss is, of course, a very serious matter to the dealer. It therefore rests with the trade to order albums that are constructed along the lines of quality and value for the money, and which will give service to their users for a reasonable length of time."

GREETINGS for 1914

The year 1913 is now but history, and at least in the talking machine business it has been a prosperous one.

We greet with **OPTIMISM** the New Year and forecast even greater prosperity for those who are alive to their opportunities. Our **DEEP APPRECIATION** is extended to those who have made our closing year prosperous.

Once again we say with **PRIDE** that the bulk of our business has come from hundreds of Dealers, and we have used every effort to safeguard their interests, avoiding neglect of the "old" while receiving and serving the "new."

We believe there is every reason to expect even **GREATER PROGRESS** to be made not only in ours, but **GENERAL BUSINESS**, during this year, for the business of the country is on a **FIRM FOUNDATION**, and there is evident a quite general feeling that "co-operation" brings better and more lasting results than "competition."

Don't overlook this, Mr. Dealer, or allow pessimists to make you lose faith in yourself or your business.

OUR POLICY for 1914 will be that of **FURTHER PROGRESS**, using the past only as a guide to avoid repeating mistakes, and considering the best results obtained, but a starting point for **FURTHER IMPROVEMENT**.

We will ask and encourage **CLOSER CO-OPERATION**, not only in our own organization but with everyone with whom we come in business contact. This is bound to produce **GOOD RESULTS**.

To **ENCOURAGE** the greatest confidence on the part of our trade, we will endeavor to be **BROAD** in our **POLICY**, giving every possible **SUPPORT** to those who deserve it consistent with good business judgment, whether it be in the extension of credit, shipment of goods or adjustment of claims.

Those Dealers who are merchants and doing their best to run their business **HONESTLY** will have our **FULL SUPPORT**, and we will in every way possible refrain from supporting, by extension of credit or otherwise, the class of Dealer who is a menace to the business and a **Bad Debt** for all concerned.

No **EFFORT** or expense will be spared to make **OUR SERVICE IDEAL** in every respect. With this object in view, give us **YOUR HELP** by pointing out **DEFECTS** in our organization that we may thus introduce **REMEDIES** where necessary.

Yours for a Happy, Healthy and Prosperous New Year.

Very sincerely

BLACKMAN TALKING MACHINE CO.

J. NEWCOMB BLACKMAN, Pres.

97 CHAMBERS ST., NEW YORK



\$250.⁰⁰ for an idea

To All Talking Machine Dealers:

1913 was a great year for the sale of Columbia Double-Disc Records—greatest we ever had.

1914 will be at least twice as great. That much is certain.

Just how much will be depends, in the last analysis, on what happens over your counter; depends on the man who comes into *your* store, puts his money down on that counter of yours and gets his records from *your* stock.

Our business—and yours—depends on that man; depends on your being able to give him what he wants. *You* know that man; you know his likes and dislikes, you know what he wants and how and when he wants it.

Now then, knowing him as you do, *you* can tell us better than anyone else what we can best do to make him buy more Columbia Double-Disc Records; more even than he has in the past; to arouse still further his interest in the Columbia Double-Disc Records.

We will give as a prize a \$250 outfit—

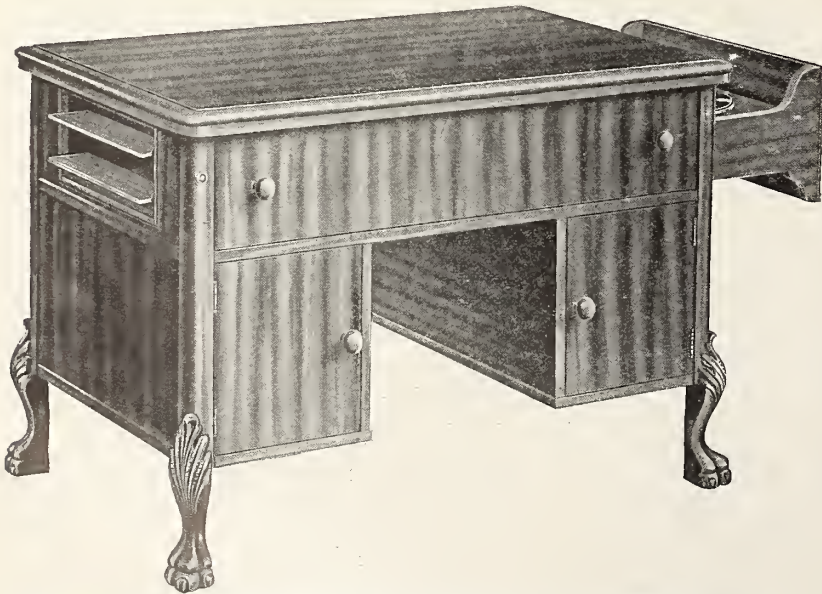

The Columbia Grafonola "Regent" at \$200.

Nothing else on the market even *looks* like the "Regent." It is a complete library or living-room table for everyday use in exactly the same degree that it is a complete musical instrument of unexampled versatility and matchless tonal qualities.

a Grafonola "Regent" and \$50 worth of records—to the talking machine dealer who suggests the best method by which we can help you to secure closer and more profitable relations with your customers.

Don't think of the reward as a mere \$250. That machine is a mere detail. The big thing for you is the opportunity it opens for the adoption and operation of your own ideas.

You may suggest some one single feature which you believe would help; or you can lay out a whole campaign—production, advertising, distribution, selling.

No need to restrict suggestions to the selling end either. If you have any suggestions to make relative to this product, send them along. Write on any point you choose, so long as it has a direct bearing on Columbia Double-Disc Records.

This offer applies to every talking machine dealer in the United States and Canada—without regard to which line of product he carries.

It is the one best chance you ever had to get some of your own ideas in this matter adopted and put into operation.

Edward Lyman Bill, Editor and Publisher of The Talking Machine World, will be the judge to decide which is the best suggestion received. This offer is open until February 15, 1914. All replies should be mailed to Mr. George W. Lyle, General Manager, Columbia Graphophone Company, Woolworth Building, New York.

COLUMBIA

Graphophone Co., Woolworth Building, New York

What we are doing

FIRST—We are *doubling* our tremendous nation-wide advertising of Columbia Double-Disc Records.

SECOND—We have given Columbia dealers a new Advertising Record at 25 cents that is getting for them the name and address of every disc talking machine owner in their territory—and *you* know full well the enormous value of such a list to you.

THIRD—Record buyers are to discover that new records are no longer a mere once-a-month event. We are going to offer new records *three times a month*—on regular stated dates. That means that your customers will find something new pretty nearly every time they're anywhere near your store—they won't have to wait a whole month between visits.

Already you have had the first of the new dance records. That was one of January's happenings. Those dance records have made more actual business than any series of records ever announced in the trade. They are made *right*—the rightest dance records ever put out.

You know how we did this, how we engaged the services of G. Hepburn Wilson, the greatest living authority on modern dancing, to rehearse those records until they were right. The result is a series of tangos, waltzes and one-steps that have no equal—the finest dance records that ever moved across your counter.

Above all, don't lose sight of the fact that this is only the bare beginning of the year—1914 is only 15 days old. The start that we have made is certainly big as beginnings go, but it is just the start of things—nothing more than that. And the rest is on the way.



COLUMBIA

Graphophone Co., Woolworth Building, New York

THE VALUE OF CO-OPERATION IN THE CREDIT FIELD.

Difficulties of Credit Grantors Twenty-five Years Ago Compared with To-day—Wisdom of Unlimited Confidence and Unqualified Co-operation Prior to Shipment of Goods Properly Estimated—Means Fewer Bad Debts and Business Progress for All Concerned.

Twenty-five years ago credit grantors were not organized and either could not or would not co-operate, and I can go back further than twenty-five years and recall how the first local representative of a mercantile agency in Nashville left hastily one night, having issued an unfavorable report, which meant in those days not a lawsuit, but powder and lead.

The next step in the progress for the improvement of mercantile agency service consisted in the substitution of a damage suit for the shotgun. So you see those who have been in credit work for a good many years can appreciate how the exchange of credit information has developed.

We passed through a time in reaching present conditions when credit grantors would not give information that would weaken confidence in a party who was in debt to them; instead, many following the policy of speaking overfavorably of a customer whose obligation they were particularly anxious to be relieved of, believing that if the customer were able to secure goods elsewhere, their chances of collecting a doubtful debt would be increased; contrarywise, we find that such offense on the part of a member of our association to-day would be almost certain grounds for expelling the offender and bringing upon him loss of the respect of his friends whom he most prizes and needs, writes J. T. Jenkins, in *The Hardware Dealers' Magazine*.

The 600 credit men organized in 1896 have increased to 16,500 in 1913, giving us, in other words, a trained army of over 16,000 keen-minded men co-operating unqualifiedly and freely for a single purpose—that of getting and, in consequence, giving information.

Is there any exaggeration in my estimate of the degree of co-operation? Let us take an example.

A few days ago I called up a member of the association about a merchant, the acceptance of whose order I was considering. I had some doubt, yet not a great deal, regarding this prospective customer. Instead of making some misleading statement, as credit grantors were apt to do a few years ago regarding a customer from whom they were trying to get relief, this member told me that he had been forced to place his account in the hands of an attorney. He realized that he could not violate confidence in the exchange of credit information. He had learned that the protection 16,000 credit men afforded him against future losses was worth many times the amount of this particular debt.

But the wonder is, if our co-operation is so genuine in the exchange of credit information, why it ceases when two or more members are interested in the same embarrassed or insolvent debtor. Why is it that an army of 16,000 keen-minded men who can work together so satisfactorily in one point become demoralized and break up into small detachments on the appearance of a good-sized bad debt?

It has taken sixteen years of earnest teaching and effort to show the credit grantors of the country the wisdom of unlimited confidence and unqualified co-operation prior to the shipment of goods. Must we wait another sixteen years before applying this concentrated intelligence, this conscientious, unqualified co-operation to the conservation of embarrassed customers of the adjustment of insolvent claims; if the experience of sixteen long years has explained the meaning of unity of action, has convinced of the value of confidence and co-operation in helping us know our customers, should such united action, confidence and co-operation decrease or become less valuable when considered in connection with or invoked in behalf of a customer who has gone wrong?

Through the national bankruptcy law brought about and kept on the statute books by the influence of our association, the adjustment bureau for the handling of insolvent accounts has not only become desirable, but essential and inevitable. The spirit of the time is appealing to the intelligence

of 16,000 credit grantors, pleading with them to accept the benefits guaranteed under this law to every honest debtor and creditor.

The value of the work of the adjustment bureau in the reduction of losses from bad debts and the importance of the relation it bears to the whole question of credit granting cannot be over-estimated, and it is to be hoped that the earnest attention of all will be directed to this branch of work and that there may be in consequence a keener appreciation of the worth of this service. That it is of worth can no longer be doubted.

SCHOOLS OF SALESMANSHIP.

How a Great Corporation Trains Young Men to Become Good Salesmen—Some Interesting Statements as to Methods Employed.

In the columns of *The Talking Machine World* there has been a steady advocacy of the establishment of schools of salesmanship in the talking machine stores throughout the country.

Along these lines it is interesting to note that the officers of the National Cash Register Co. have made perhaps the greatest study of the subject of teaching their selling force than any other corporation in the country.

They have established a factory school where they teach the members of the selling staff everything in relation to the selling of their products.

In a recent address delivered before the Convention of Corporation Schools held in Dayton, O., R. H. Grant, assistant to the sales manager, made a very interesting address in which he described at length the method adopted by the National Cash Register Co.

The course of instruction covered five weeks, and the students' expenses are borne by the company. There is a regular outlined course of study. Written examinations are given to make the men work, and diplomas are awarded to show how they have completed the course. This corporation believes that to have a good selling organization you must get good men. Then when you get them, you must train them. In other words, train everybody to make good at the selling end of the business.

Mr. Grant said in the course of his remarks:

"We carry on post-graduate schools. There are times when we take men into the factory and have a school of sixty to seventy men that we pick from our selling force, men who four or five years ago went through the elementary school; men that we believe need to come back here, and while they may be excellent men and be making good records, we feel that if they come back here and see what we have, see the new things that are proposed, the opportunities that exist, come here and work under a competent instructor, that they will be bigger and better and more self-reliant when they go back into the field.

"Then we have the Owl Classes, which give our people here in the offices the rudimentary ideas of selling with a view of making them better men, because we broaden the scope of their vision, and also prepare them for outside positions later on.

"Those make up the different teaching features of our selling department. I trust in this explanation I have made clear the idea that education must begin in an elementary way and go on through post-graduate courses *until you have a lot of men who will take care of their own education, and until you do that you cannot have an ideal selling force that can be called successful.*

"In our training school we take up the following subjects: Preparation, Advertising, Weaknesses of systems in use, The approach, The re-approach, Installations, Collections.

"In taking up these subjects in the school the instructor uses plain business language. We can only use to advantage scientific and psychological data after it has been reduced to simple English.

"We believe in small words and in big ideas. The president of our company has always taught us that way. We believe in all the psychological

research possible, we believe in all the tabulation of scientific data that is possible in order that when the facts are understandable to the ordinary man, we may make use of them. We believe in practical salesmanship; we believe in having men who understand what they are talking about and having them put it up to the man in front of them so that they will know what is being talked about, and we don't believe you can do it in high-flown terms. If we picked a group of highly-educated men they might understand what was being discussed if you used big words, but you cannot do that with salesmen as a rule. To be successful, salesmen must have a desire to sell; they must have courage, ability to work; they must be loyal to the company and so forth, but they do not necessarily have to be more highly educated than the trade they call upon, consequently the teaching should be in the most simple language.

"I want to say a word on the subject of advertising and selling as a combined subject. In our schools you notice the second subject is advertising. It is an important subject to a salesman, and the trouble is that most salesmen and managers do not know it and many times sales and advertising managers are not co-operating as they should. Advertising matter is not being used by salesmen as it should. Much money is being spent and there is a waste unless you get close connection between the two departments.

A HEARTY NEW YEAR'S GREETING

Sent the Trade by the National Publishing Co. of Philadelphia—Closed a Great Year in the Sale of Record Albums and Expects a Bigger Business During 1914.

The National Publishing Co., 235 South Market street, Philadelphia, Pa., who have built up a large business in talking machine record albums have just sent out a New Year's greeting to the trade, in which they say:

"The old year has passed through the gate that swings but one way, and the air is full of good resolutions; if one-half of them are kept, two-thirds of our sorrows will fade away. There is not much to be had in this life unless you go after it, so wish yourself some and in doing so put your heart in it, but do not put your foot in it. 'Wisdom consists largely in knowing when to quit.' Our wish for you is a happy and prosperous new year."

The record albums made by the National Publishing Co., have won a large degree of favor throughout the trade by reason of their durability, artistic design and finish. With the index they form a very complete system for filing disc records, and while invaluable to those who have no cabinets on hand, they also form a very important adjunct to those having cabinets and a surplus number of records, for through the aid of record albums they can be filed away most conveniently.

The record album trade is proving quite a trade factor with dealers who are pushing it intelligently, and bringing the value of the record to the attention of record customers. The fact that it makes record stock sightly in the home is a point worthy of emphasis.

INTEREST ON UNPAID PAYMENTS

Being Discussed in Indianapolis and a Special Committee Appointed to Take Up This Matter—Victor Dealers to Be Interviewed.

Robert O. Foster, of Foster & Waldo, has been named as a committee of one to interview the Victor dealers in Minneapolis, about ten in number, and to urge an agreement to exact interest on unpaid amounts due on talking machines sold on the instalment plan. Most of the persons interested are piano dealers, and they see no distinction between piano purchasers and Victor purchasers in the matter of granting concessions on instalment payments. However, Mr. Foster has encountered some opposition to the plan, but expects to convince the objectors that the plan is for their interest.

At the present session of Congress efforts will be made to advance, by gradual steps, the rate limit on packages sent by parcel post, until the hundred pound limit is reached.

REMARKABLY LARGE SALES REPORTED IN MILWAUKEE.

Not Only for December but for the Year—This Applies Pretty Much to All Concerns in That City—Our Correspondent Presents Some Interesting Data in This Connection Which Make an Impressive Showing Regarding Holiday Business—News of Month.

(Special to The Talking Machine World.)

MILWAUKEE, Wis., January 10.—Despite the dullness experienced in some lines of industry during December, Milwaukee talking machine dealers met with an exceptionally fine holiday business. In fact, there is hardly a Milwaukee house which did not establish a new high record in the sale of both machines and records. Sales of lower-priced machines may not have been quite as heavy as usual, but this was more than offset by the remarkable business secured in machines ranging in price from \$50 to \$200. One Victor retail house disposed of \$4,000 worth of machines and records during December, while two well-known piano houses carrying the Victor line, sold approximately \$5,000 worth of goods during the past month.

Jobbers say that dealers about the State sent in rush orders for stock almost up to Christmas day, and that the total volume of business in the wholesale field was more than satisfactory. Dealers seem to be unusually low on stocks after the holiday rush, and most of them are placing some good orders, that they may get their stocks up in normal shape once more.

The outlook for the coming year seems to be bright at this time, and jobbers and dealers are confident that a good business will be experienced.

The Milwaukee Phonograph Co., jobber for the Edison line, met with a big business in disc machines and records during the month of December, according to William A. Schmidt, general manager. Dealers seem to be more than pleased with the new Edison machines. Joseph A. Bitts, of Kenosha, Wis., who recently installed the Edison line, and W. J. Augustine, Fond du Lac, Wis., and John R. Bolz, Kiel, Wis., were recent visitors. A large number of new Edison dealers were secured before Christmas.

Business has been so good with the Smith-Gensch Co., 730 Grand avenue, enterprising retail Victor concern, that it has put out two new outside salesmen, covering Milwaukee and Milwaukee County. Sales of Victor machines and records during the holiday period attained a new high mark with this house.

J. H. Ellis, the inventor of the "Real Tone" diaphragm, has been made the manager of A. G. Kunde's branch, at 3410 North avenue, opened a few months ago. Mr. Ellis is enthusiastic over the Columbia line, and ought to meet with success in his new field. Mr. Kunde says that the holiday trade at both his downtown and branch stores was exceptionally good.

The W. H. Aton Piano Co., which handles the Victor and Edison lines in Madison, Wis., is meeting with particularly good success. Several new Victor dealers have been secured about Wisconsin by the Wisconsin Talking Machine Co.

The Edmund Gram Music House met with unusual success during the holiday period and Victor sales climbed to a new high mark, says Paul A. Seeger, manager of the Victor department.

The Victor department at Gimbel Brothers, under the management of L. C. Parker, experienced a gain of 41 per cent. during December, as compared with the corresponding month in 1912. There are six demonstration parlors in the Victor hall at the Gimbel store, but Manager Parker says he could have used ten more during the holiday rush

and that he could have increased his total sales as a result.

The Victor talking machine departments at the two stores of Edward Schuster & Co., met with a fine holiday business and good sales are reported by Miss Frances Elman, manager of the department at the Twelfth and Vliet street store, and Miss Elizabeth Hughes, manager of the Third and Garfield street establishment.

C. W. Abbott, enterprising young manager of the Victor department at the Boston store, and Miss Jule Steiner, in direct charge of the Victor department at the J. B. Bradford Piano Co.'s store, are enthusiastic over the big business secured by their departments during the month of December. The Bradford house has been following the scheme of allowing the piano salesmen to round up talking machine sales when out on piano prospects, and the results have been more than satisfactory.

There are rumors afloat in Milwaukee that another new retail talking machine store will be opened in the downtown district within the near future by the jobber of a well-known line. The more the merrier.

The Heller Piano Co., which was forced into involuntary bankruptcy some months ago, a concern which carried the Victor talking machine line, filed its schedule some time ago, disclosing liabilities of \$248,310.03, and assets of \$421,760.81.

ENTHUSIASTIC OVER THE PROSPECTS.

A. W. Toennies Reports Big Gain in Business of the Eclipse Phonograph Co., Edison Disc and Cylinder Jobbers, for Year Just Closed—Many Dealers Signed Up.

"After closing the best year in our history, we are naturally enthusiastic over the immediate prospects for spring trade," stated A. W. Toennies, of the Eclipse Phonograph Co., 203 Washington street, Hoboken, N. J., jobbers of Edison disc and cylinder products exclusively. "Our gain over 1912, our former banner year, was surprisingly large, and the most gratifying feature of the Edison business is the fact that our business this month up to date shows a substantial increase over January, 1913, and steadily growing.

"The Edison disc line is certainly increasing in popularity at a remarkable pace. Since the first official announcement by Thomas A. Edison, Inc., a few months since, we have been signing up new dealers day by day, and those members of the trade who joined the Edison disc band-wagon in the fall have all advised us of the closing of an excellent holiday business. The musical qualities of the Edison disc product, coupled with the advertising that is now appearing in all parts of the country, have certainly contributed in a large measure to this impressive success.

"The hornless types of Edison cylinder phonographs are maintaining a steady popularity with our dealers, and it is pleasing to note that the demand seems to be strongest for the higher-priced hornless machines in preference to the cheaper models. As a matter of fact, the outlook for both Edison disc and cylinder products is very encouraging, and we expect 1914 to be even better than last year."

"ONE PRICE" A DISTINCT BENEFIT.

The Supreme Court of the State of Washington So Holds in a Very Important Decision Handed Down Last Week, and Which Is of Interest to Those in the Talking Machine Trade, as Well as Those in Other Industries, Who Believe in the Maintenance of Prices.

A decision of exceeding importance to the talking machine trade, and to all who believe in price maintenance, was handed down by the Supreme Court of the State of Washington last week in an action brought by the Fisher Flouring Mills Co. against a retailer who had cut the price of his products contrary to agreement.

The suit brought by the milling company was defeated in the lower court. The decision of the Supreme Court of Washington was handed down by an eight to one vote, and the Fisher Co. granted injunction and damages; the findings of the lower court reversed, and thus an important step taken toward the recognition of the one-price-to-all has a distinct benefit to the consumer. In its opinion the court says in part:

"In the absence of a monopoly, either actual or potential, a contract fixing retail prices to the consumer cannot have an effect appreciably inimical to the public interest, because it cannot fix prices at an unreasonably high figure without defeating its own purpose by either signally failing to maintain the fixed price or putting the individual manufacturer out of business. In either case it fails to restrict competition.

"The true competition is between rival articles, a competition in excellence, which can never be maintained if, through the perfidy of the retailer who cuts prices for his own ulterior purposes, the manufacturer is forced to compete in prices with goods of his own production, while the retailer recoups his losses on the cut price by the sale of other articles at or above reasonable price.

"It is a fallacy to assume that the price-cutter pockets the loss. The public makes it up on other purchases. The manufacturer alone is injured, except as the public is also injured through the manufacturer's inability, in the face of cut prices, to maintain the excellence of his product.

"Fixing the price on all brands of high-grade flour is a very different thing from fixing the price on one brand of high-grade flour. The one means destruction of all competition and of all incentive to increased excellence. The other means heightened competition and intensified incentive to increased excellence. It will not do to say that the manufacturer has no interests to protect by contract in the goods after he has sold them. They are personally identified and morally guaranteed by his mark and his advertisement."

Recent United States Supreme Court decisions, while forbidding the manufacturers of patented and copyrighted goods to set the retail price, have been based upon the assumption that the producers involved in the particular actions were actual or virtual monopolists, and these decisions have stopped short of the point as to whether it is legal under any circumstances for a maker to set the price at which the consumer may buy the goods.

A new home disc recorder has just been designed by Senor Alvaro Malibrán, a Spanish inventor, which is described as a strongly constructed mechanism with all the exterior parts nickled. It is claimed for this device that it is adaptable to any disc talking machine, and will reproduce a big volume of sound with remarkable tone fidelity.



The Columbia automatic stop. The most accurate automatic stop made and the easiest to operate.

Gun Metal, \$2.00 list. Nickel Plated, \$2.50 list. Gold Plated, \$3.00 list.

May be adjusted to both Columbia and Victor disc machines. Order from any Columbia Distributor.

A HANDSOME ORDER BOOK.

Has Just Been Sent Out to Its Friends by the
New York Talking Machine Co., New York—
Convenient and Very Handy for the Dealer.

The New York Talking Machine Co., 81 Chambers street, New York, the well-known Victor distributor, is now sending out to its trade a handsomely bound order book, which in addition to being attractive and artistic, is primarily a book which can be used by the dealers to excellent advantage. The company has in former years sent out order pads to its trade, but this year it was decided to design a book which could be used the year round, and afford the dealer an opportunity to place his orders with a maximum of convenience.

The order book which is now being mailed to the New York Talking Machine Co.'s trade, is intended for those dealers on the company's books who have purchased their machines and records during the year with any degree of regularity, and the dealers who have already received their books, are enthusiastic in their praise of its many merits.

The book which is designed along the lines of a loose-leaf folder, permits the dealer to insert another order pad as soon as one is finished, as the leather covers make a permanent folder. Each order pad has carbons attached to the original orders, so that the dealer has a reference file of all the orders he has placed. The order pad is furnished with perforated lines, making the ordering of goods convenient to a degree.

This new order book is bound in an artistic dark green limp leather binding, with the name of the New York Talking Machine Co. suitably printed on the cover. The famous dog trademark of the Victor Co. is shown on the center of the front cover, and the entire arrangement is one of dignity and refinement. The individual dealer's name is printed in gold on each book, giving an atmosphere of personal ownership, which naturally adds to the attractiveness of the book.

The New York Talking Machine Co. is to be congratulated on its latest co-operative plan, as this

book represents a valuable time-saver for the Victor dealer.

NEW EDISON DEALERS

In New York City and Adjacent Territory
Given Out by Thomas A. Edison, Inc.—List
Is Steadily Growing as Sales Increase.

Thomas A. Edison, Inc., Orange, N. J., has been featuring in the daily newspapers the past few weeks, an interesting list of some of the Edison disc representatives in local territory, who have taken on the line during the past few months. This list, which is constantly growing, gives a fair indication of the popularity that the Edison disc phonographs and records are achieving in this territory.

The public was invited to attend demonstrations at the stores mentioned in the advertisements, and this invitation was responsible for the drawing of interested visitors to the establishments of the dealers, which resulted in the closing of many sales.

Among the names presented in these Edison disc advertisements, were the following: Hardman, Peck & Co., Tower Manufacturing and Novelty Co., Fred Kraft, Inc., Krakauer Bros., M. Goldsmith, George Bergmaier, Paul Helfer, Cort Sales Co., and Sol. Lazarus, all of New York; Hardman, Peck & Co., B. Guy Warner, Alphonzo Smith, Charles G. Rosewell, Louis Chevalier, George S. Uniss, Guarantee Phonograph Co., T. H. Clancy and A. Eckel, all of Brooklyn, N. Y.; Frank Stedman, 41 Warburton avenue, Yonkers, N. Y.; Yonkers Talking Machine Co., 37 Palisade avenue, Yonkers, N. Y.; Albert Galuchie, 492 Communipaw avenue, Lillie Heidenfelder, 370 Central avenue, Henry Rau, 110 Monticello avenue and William Ricker, 658 Newark avenue, all of Newark, N. J.; the Quackenbush Department Stores and James Rigby, Paterson, N. J.; James L. Abbott & Son, Fort Lee, N. J.; Henry F. Schmidt, 200 Main street, Orange, N. J.; Fred G. Loeffler, 260 Bergenline avenue, Union Hill, N. J., and Henry A. Maas, 417 Spring street, West Hoboken, N. J.



NYOIL

For polishing
varnished woodwork, it is
extremely satisfactory. No oil is so clean.

*Ask your watch repairer whose
oil he uses on your watch.*

SPANISH RECORD CATALOG.

The export department of the Columbia Graphophone Co. issued this week its annual Spanish record catalogue, which, in addition to being considerably thicker than the 1913 edition, embodies a number of distinctive features which constitute a decided improvement as compared with former editions. Valuable indexes and appropriate photographs add to the artistic appearance of the new catalogue.

H. L. Willson, assistant general manager of the Columbia Graphophone Co., is expected back early next week from a short trip through the important trade centers of the Middle West, where he has been receiving good reports regarding business.

Mr. Dealer:

\$witky \$ervice \$pells \$uccess for YOU

IT MEANS The Machines and Records You Want, When You Want Them.

Expert Assistance in Making Sales of Machines and Records Whenever Required.

Expert Instruction in the Proper Care and Repair of All Styles of Machines.

Expert Assistance in Writing Advertisements and Preparing Publicity Matter of All Kinds.

An Exchange Bureau for Surplus Victor Stocks Among the Dealers.

A System of Credit That Is as Liberal as Possible Under All Conditions.

You Pay for the Goods—the Service, Tested and Successful, Is Free.

BENJ. SWITKY, Victor Distributor
No. 9 West Twenty-third Street, New York City

NOTED ARTISTS SIGN WITH COLUMBIA

Margarete Matzenauer, the Famous Operatic Contralto, and Eduardo Ferrari-Fontana, Tenore Robusto, to Make Records for the Columbia Co.—Both Artists Have Achieved Great Success in Opera.

The Columbia Graphophone Co. closed a number of important new deals with prominent artists during the past few weeks, whereby the Columbia record library will add to its lists many new records within the next few months. These additions form valuable helps for Columbia dealers with patrons who appreciate operatic music.



Margarete Matzenauer.

The most important of these new Columbia acquisitions are Mme. Margarete Matzenauer, the internationally famous contralto of the Metropolitan Opera Co., New York, and Eduardo Ferrari-Fontana, a member of the Boston Opera Co., whose splendid performance last week at the Metropolitan Opera House in the leading tenor role of the new opera, "L'Amore di Tre Re," was one of the events of the operatic season.

Mme. Matzenauer, although she has been a member of the Metropolitan Opera Co. but a few years, has achieved a noteworthy success in this short time, and has won the admiration and praise of the leading musical critics of the country. Her voice, which is a rich contralto, has been generally commended by all operagoers for its many musical qualities, and her success in the Metropolitan Opera Co. has earned for her a prominent position among the leading contralto singers of the world. Her records will be valuable additions to the Columbia Co.'s operatic library, which is growing steadily.

Eduardo Ferrari-Fontana, in addition to achieving a country-wide reputation through his Boston Opera Co. appearances, scored an instantaneous success in his initial New York performance in the new opera at the Metropolitan Opera House. Referring to this opera, the musical critic of a leading New York morning newspaper said:

"The performance of the new opera was notably fine. Its most conspicuous feature was the first appearance in the Metropolitan Opera House of Eduardo Ferrari-Fontana, who took the part of 'Avito.' Mr. Fontana, it is understood, had sung the part in some of the earliest performances of it in Milan. He made an immediate success, not only by his fine and impassioned acting—acting of genuine tragic temperament and of finished skill—but

WANTED.—Wholesale man to sell Victor goods exclusively; must have a knowledge of the trade in New York City and surroundings; employment on a salary and commission basis. All communications held strictly confidential. Address Max Landay, 563 Fifth Avenue, New York.

WANTED.—Intelligent saleslady to sell Victor Talking Machines. Good position to the right party. Write, stating full particulars in first letter, "No. 600," care The Talking Machine World, 373 Fourth Avenue, New York.

NEW IDEA IN CABINET TALKING MACHINE.—I have an entirely new idea in a Cabinet Talking Machine, and would like to hear from any party in reference to financing the same. Address "K. R., 12," care The Talking Machine World, 37 So. Wabash Ave., Chicago, Ill.

WANTED.—Capable young man, experienced in selling Victor Talking Machines; to such a salesman is opened a permanent position with chance of advancement; must be steady and a hard worker. Write giving full particulars. Address "No. 602," care The Talking Machine World, 373 Fourth Ave., New York.

still more on account of his remarkably beautiful tenor quality. He is a true 'tenore robusto,' with not only power but also fullness, richness and warmth of tone, splendid resonance and penetration, especially in his upper ranges. Mr. Fontana sings with admirable art, with style, in a manner that makes his voice count for its utmost. He would seem to be a valuable acquisition for the Metropolitan Opera House. If Mr. Fontana's future appearances bear out the promise he offered in his first one, his work in New York will be watched with interest and pleasure."

OUR FOREIGN CUSTOMERS.

Amount and Value of Talking Machines Shipped Abroad from the Port of New York for the Past Four Weeks.

(Special to The Talking Machine World.)

WASHINGTON, D. C., January 9.—Manufacturers and dealers in talking machines will doubtless be interested in the figures showing the exports of talking machines for the past four weeks from the port of New York.

DECEMBER 13, 1913.

Birkenhead, 11 pkgs., \$283; Cambay, 6 pkgs., \$148; Guayaquil, 25 pkgs., \$1,071; Kingston, 10 pkgs., \$339; Liverpool, 6 pkgs., \$225; London, 2 pkgs., \$102; 265 pkgs., \$13,382; Manila, 41 pkgs., \$2,743; Mexico, 24 pkgs., \$462; Skandhai, 44 pkgs., \$1,013; Singapore, 6 pkgs., \$202; 6 pkgs., \$129; Valparaiso, 17 pkgs., \$982.

DECEMBER 20.

Berlin, 1 pkg., \$148; Buenos Aires, 85 pkgs., \$8,061; Dominicia, 14 pkgs., \$229; Guayaquil, 9 pkgs., \$272; Havana, 7 pkgs., \$970; Milan, 5 pkgs., \$485; Montevideo, 49 pkgs., \$4,380; Port au Prince, 19 pkgs., \$364; Porto Plato, 12 pkgs., \$499; Rotterdam, 23 pkgs., \$549; St. Johns, 6 pkgs., \$169.

DECEMBER 27.

Callao, 17 pkgs., \$1,083; Cardiff, 1 pkg., \$179; Guayaquil, 14 pkgs., \$1,933; Havre, 4 pkgs., \$557; Liverpool, 14 pkgs., \$479; London, 327 pkgs., \$8,128; 526 pkgs., \$9,008; Manaos, 17 pkgs., \$1,139; Manila, 89 pkgs., \$2,709; Maracaibo, 3 pkgs., \$113; Rio de Janeiro, 8 pkgs., \$537; San Chiz, 4 pkgs., \$111; Vera Cruz, 31 pkgs., \$1,450.

JANUARY 3, 1914.

Arica, 3 pkgs., \$463; Bahia Blanca, 9 pkgs., \$467; Belfast, 8 pkgs., \$217; Bradford, 7 pkgs., \$191; Brussels, 3 pkgs., \$142; Callao, 27 pkgs., \$1,505; Copenhagen, 22 pkgs., \$1,218; Havana, 28 pkgs., \$711; Havre, 6 pkgs., \$205; Liverpool, 27 pkgs., \$1,833; Manchester, 7 pkgs., \$465; Montevideo, 7 pkgs., \$618; Naples, 2 pkgs., \$207; Newcastle, 8 pkgs., \$287; Rio de Janeiro, 4 pkgs., \$318; Sheffield, 4 pkgs., \$219; Soerabaja, 9 pkgs., \$349; Valparaiso, 15 pkgs., \$411.

TELEGRAPH ERROR RULING.

Company Not Responsible Unless Gross Negligence Is Proved.

(Special to The Talking Machine World.)

ALBANY, N. Y., January 8.—It is important to members of the piano trade and business men generally to know that a telegraph company is not responsible for errors made in a message unless they are the result of gross negligence. This is the opinion handed down by the Court of Appeals held recently.

This opinion was handed down in the case of Stephen M. Weld & Co., cotton brokers, against the Postal Telegraph Co. Weld gave an operator in the New York office a message to sell 20,000 bales of cotton at not less than 12.70 a pound, and, owing to an error in the message, it was sold at 12.07, thus inflicting on Weld a loss of \$27,565.

On the first trial of the case Weld obtained a verdict for \$10,000 damages. The Court of Appeals sent the case back for a new trial because of error in the charge to the jury. A second jury gave Weld a verdict of \$36,684. In reversing this verdict to-day because of error and granting a new trial, the Court of Appeals explained that proof of gross negligence would be necessary to warrant giving Weld a verdict. The opinion was unanimous.

There are many who cannot enjoy the sunshine of to-day for fear it will rain to-morrow.



A Big Money Making Opportunity for Talking Machine Men

Do you know how best to improve your business?

Try pianos and player-pianos.

We have the best player-piano proposition in America, barring none.

We can offer it to you right.

We can put you absolutely on the inside so far as pianos and player-pianos go.

Our facilities and our knowledge of the trade situation enable us to do this.

We can build your business so that it will show a substantial growth in profits long before the close of the year.

That sounds interesting, does it not?

Take the matter up with us, not soon, but now—just now, when the year is young and the opportunities for good business lie before you.

Remember, every day—every week—every month that you delay investigating this piano proposition you are standing in your own light. You are making the business corners of your establishment dark, when they should be illumined by good, bright piano sunshine!

We have built one of the largest piano enterprises in the world through the delivery of values.

H. P. NELSON COMPANY

Makers of Grands, Uprights and Player-Pianos

North Kedzie, North Sawyer, West Chicago Aves and C. M. and St. Paul R. R., CHICAGO

SUBSTANTIAL REASONS FOR OPTIMISM IN 1914.

Prospects of the Year Interestingly Analyzed by J. Newcomb Blackman, the Prominent New York Jobber, Who Says That the Man Who Has Been Running His Business on a Conservative Basis Need Have No Fear as to Business Progress in 1914.

In response to a request for his opinion as to the business outlook for 1914, J. Newcomb Blackman, president of the Blackman Talking Machine Co., the prominent Victor and Edison distributor, said: "Analyzing the prospects for the year, in my opinion, those who are in a position to do business under normal conditions, have every reason to be optimistic regarding the future, as the prospects are decidedly bright. By this I mean the man who is not on the ragged edge, but who has been running his business on a conservative basis, need not have any fear as to business for 1914.

"The whole question of the year's prosperity naturally hinges on the condition of the country itself. We have for sometime been living in a state of unrest. This includes the entire American people—the wage-earner, the business man and the Government officials. The wage-earner naturally did not know to what extent he would be affected by such action as politics might bring about in business. The business man was uncertain and fearful as to what might happen on account of the changes in politics and the agitation of the wage-earner.

"All factors in the business world, however, have sobered up somewhat during the past few months and have begun to realize that we have reached the point where we must co-operate. The wage-earner is beginning to understand that there is a limit to what he is entitled and can earn from an economic standpoint. The business man feels that the simplest and best way to meet conditions is to co-operate both with the Government and with his employes. The Government is beginning to view the situation as calling for safe and sane legislation based on results for the people.

"In other words, during the past year or two, we have attempted to undo and straighten out a

condition which it has taken many years to develop, and extreme measures are now being recognized as inadvisable. The so-called trust seems ready to admit the irregularities of its methods and shows a disposition to peacefully adjust



J. Newcomb Blackman.

its affairs. The Government apparently invites such adjusting with the President as spokesman. The bankers, who have been so much agitated over the currency bill, evidently hoped for more than they ever expected to receive and have settled down to the conclusion that the present bill is

something better than they had originally hoped for.

"Pessimists can find no real basis for their contentions, for the country is prosperous at its source of production, which is the crop production, and business has benefited by the enforced conservatism following the panic of 1907. The wage earners are getting better wages to-day than they have ever received, and if the new tariff law does not reduce the cost of living, there is at least the prospect of it halting the constant increase. The income tax will, no doubt, fill in the gap, placing the burden on those who can best stand it and removing it from those who have stood it in the past and felt it most. This situation, I believe, is simply an adjustment of conditions in response to a general demand, and so long as this demand is general there can not be serious opposition and therefore no ground for pessimistic and discouraging views.

"The talking-machine business stands practically where it has been, not only because the goods have merit and the prices and discounts are reasonable, but because of the frank and open manner in which the business has been conducted. Whatever restrictions there have been placed around the talking-machine business have been well known and participated and shared in alike, and the public has always been protected by quality and price without discrimination.

"The sane level, on the part of the Government, between the abuse of over restriction as against open competition will, I believe, soon be reached, and the aggressive methods of the manufacturers, through their manufacturing, advertising and marketing of goods, coupled with a never waning desire on the part of the public for music and the unlimited variety of the talent offered, will, to my mind, cause the talking-machine business to show a healthy increase. In view of this I do not think any manufacturer, jobber or dealer who has reasonable capital and ability, need have any fear about the future, for if there have been any "hard times," I think they have passed as a reality or as threatening clouds."

Mr. Dealer: Could you spend but five minutes in going over the letters we have received from dealers and consumers in all parts of the country you would be just as enthusiastic as we are about the Masterphone. Now that the Masterphone for Fibre Needles is ready for delivery, you have an exceptional opportunity to sell your customers an attachment that will give them the best there is in the records with the assurance that there is absolutely no wear on the records.

The Fibre Needle Masterphone retails at \$1.50. Regular trade discounts apply, assuring you of a good profit.

Inquiries from localities in which we have dealers are referred to them.

The Fibre Needle
MASTERPHONE
Retails for
\$1.50

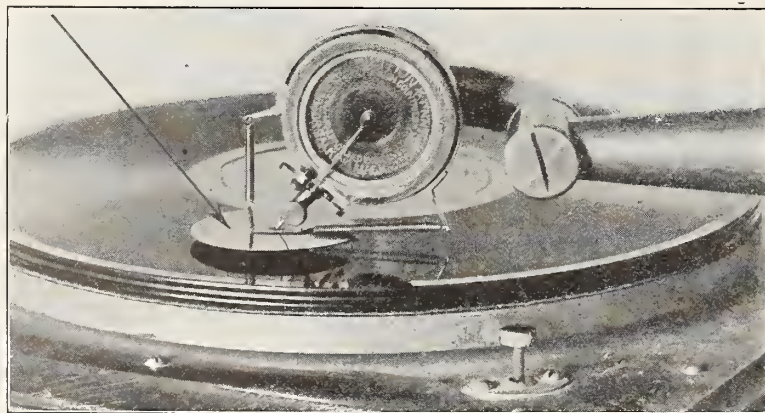

Write to-day for
Trade Discount
and
Full Particulars

THE MASTERPHONE CORPORATION, 187 Broadway, New York City

Telephone: Cortlandt 1872

CLOSER RELATIONS BETWEEN JOBBER AND DEALER.

F. H. Silliman, of the Pardee-Ellenberger Co., Is Firmly Convinced That One of the Best Ways Whereby the Jobber Can Promote Closer Relations with His Dealer Is to Have the Right Kind of Men on His Traveling Force, Who Will Act as Business Advisers.

Many men prominent in the phonograph trade have discussed this subject at various times. It is of great importance to both jobber and dealer, and one open to much difference of opinion.

From my own observation, covering a number of years as a traveling salesman, and later as manager of traveling men, I am firmly convinced that one of the best ways the jobber can promote closer relations with his dealers is to have the right kind of men on his traveling force, calling at regular intervals on the dealer.

The kind of traveling man I have in mind, studies his territory in a thoroughly scientific manner, and knows the particular requirements of each individual dealer that he calls upon. He is of great help to his dealers; they look to him for suggestions; he often arranges their advertising and shows them how to display their line to the best possible advantage. He is the dealer's right hand man, often standing between him and the jobber on the matter of credits; for the credit man must rely to a considerable extent on the traveling man's thorough knowledge of his dealers.

The right kind of a traveling man will fight for his house to the last ditch when on the road, and when he gets to the office will fight for his dealer's interests in the same manner. In a large territory, very few dealers get to know anyone connected with the jobbing house but the traveling man, and the impression he gets of the traveling man is his impression of the whole concern. Often a dealer will have a prospective customer for a high-price phonograph which he cannot close. Here is where the traveling man should shine to

PREVENTING FREIGHT LOSSES.

Caution on the Part of Consignee in Checking Weights and Rates and in Watching for Loss or Damage Will Save Much Trouble.

A large part of the delay and trouble experienced by shippers, in the matter of claims for freight overcharges and in the securing of prompt adjustment of claims for loss or damages, is attributable to negligence on the part of the receivers (consignees) of freight, who frequently are not interested in the overcharge or loss or damage, charging the same back to the shipper.

With the purpose of securing co-operation and improved methods on the part of receivers of freight, they should weigh their freight and check the rates applied, so as to insure the proper charge and thereby avoid an overcharge. The receiver of freight should likewise require the proper notation to be made on the freight bill by the delivering agent in the case of loss or damage apparent at time of delivery, and in the case of concealed loss or damage he should make an immediate report to the delivering agent.

With the view of securing co-operation of the receivers of freight, we recommend the preparation of a small blank, six by three inches, to be used as an "insert" with the transmission of bills of lading or shipping tickets of the following form:

"Important—Weigh your freight and check your rates. Examine goods before accepting. Do not give clear receipt if damaged or short. We hold a clear receipt for the transportation company that the goods have been delivered to them in first-class condition."

To prevent overcharge carefully check the weights of the items received against the weight on the freight bills. Have rates verified when you have reason to believe they are incorrect. Insist upon agent correcting charges to basis of actual weight and tariff rate.

Require agent to endorse upon original freight bill shortages disclosed at time of delivery, and in case of damage to make notation on freight bill of the exact nature and extent of damage.

Concealed loss or damage disclosed after delivery upon opening a package should be immedi-

ately reported to the delivery agent, and an exception requested with statement of the facts disclosed.

advantage, both for the dealer and the firm he represents. He should devote enough of his time, and the time of the jobber who employs him, to make this sale that the dealer is unable to close. This should be comparatively easy for the traveling man, as the prospect is bound to be impressed by one who represents the jobber. The traveling man has a mind full of similar cases, and his sales talk is bound to be more impressive than any talk the dealer could give. If the sale is made, the jobber has certainly helped the dealer and promoted a closer relation between them both.

What the new dealer needs is education; and speaking for ourselves, we teach him. Our salesmen are not only salesmen in every sense of the word, but are business advisers. As an institution, we are trained to act as the new dealer's counsel; to advise him about the technical features of the machines; to instruct him on the scope of the records and their value as a permanent monthly income; to assist him in writing advertisements and in the promotion of business; to help him secure a firm footing on the rocky ledge of credits; to show him about window displays, advertising and other publicity; and, in fact, aid him in a hundred and one ways for the successful growth of his business.

What all jobbers and jobbers' assistants should remember is that there is a great deal more than the bare sale of goods to the dealer; and when they do bear this clearly in mind they will find retail distribution on a more efficient basis; and after all, it is the retail sales that count with the jobber.

ately reported to the delivery agent, and an exception requested with statement of the facts disclosed.

A TRADE VETERAN HONORED.

Banquet Tendered Edwin E. Forest by His Friends Upon His Seventieth Birthday—Long Connected with Talking Machine Trade

An affair of much interest was held this week at the Carlos Restaurant, New York, when a number of friends of Edwin E. Forest in the talking machine trade tendered him a banquet in honor of his seventieth birthday. Mr. Forest, who has had a long and interesting career in a number of fields, starting in the lumber business and progressing through the provision, restaurant, confectionery and printing trades, was one of the first to enter the talking machine field in its early days and was ranked as a recording expert with the old New York Phonograph Co., Leeds & Alcock, and finally the Leeds & Catlin Co., until the latter concern was forced out of business some years ago. Mr. Forest is at present actively connected with the talking machine department of Gimbel Bros.

Those present at the dinner, which was later followed by a dance, included, besides Mr. and Mrs. Forest, George W. Morgan, manager of the piano and talking machine departments, and J. H. Dodin, head of the talking machine department of Gimbel Bros.; Benj. Switky, who acted as toastmaster, and I. Davega, Victor distributors; Lippman Kaiser, and others to the number of twenty.

TO FEATURE ADVERTISING RECORD.

The popular Columbia advertising record will be featured in the two Columbia advertisements to appear this month in the Saturday Evening Post, one on January 17 and the other on January 24. Special combination lists of records which can be obtained at certain prices will also be presented, as this listing of records is generally commended by the trade as productive of numerous record sales that may otherwise have been lost temporarily.

SUCCESS ISN'T MATTER OF RULES.

"Something Inside a Man," Says English Leader—Know Men Who Win.

Writing in Pitman's Magazine, a new English publication devoted to business, A. E. Bull outlines the kind of people it is necessary for the man to know who would find success in the commercial world. Says Mr. Bull:

"A remarkably successful man, who had commenced in poverty and who had built up a world-famous business, was once asked to explain the secret of his success.

"My dear man," he said to the interviewer, "it can't be done. I can no more tell you how I succeeded than a bird could explain how it learned to fly."

"But," protested the interviewer, "you surely have some rules of conduct and business methods that you have adhered to through life, and which would account for your success?"

"Yes, I have rules," replied the successful man, "but rules are nothing. Success isn't a matter of rules. It's something inside a man, something that belongs to his nature and character. If a man has it, he will succeed; if he hasn't, all the copybook headings in the world won't give it to him."

"That was the opinion of a man who had succeeded and knew his own nature, and, up to a point, it has a great deal of truth in it.

"Here is a second reply to the question which was put to the millionaire. The man who made it was by no means so prosperous, but he had succeeded beyond reasonable expectations. He was certainly more successful than those who knew him best thought he would be, for he was not a particularly able man in any way.

"I made one rule in life," he said. "I regard it as a duty to succeed, so I persistently sought the company of those who had succeeded. If a man was a failure I avoided him, not out of any snobbishness, but because I could not afford to run the risk of catching the infection of failure from him."

"His was a most curious idea, that success and failure are infectious, and that one can catch them just as he can catch fever and colds. Here is the point of the remark and the truth of it. It is just the same opinion as that of the millionaire, though presented in a different way:

"The things that bring success are the things that belong to character. To succeed one must mold the character aright. Nothing influences character so much as companionship. In his mind it worked out this way: Make companions of weak people and one becomes weak; make companions of strong people and one becomes strong."

Welcome trials, for remember it is usually difficulties and responsibilities that bring a man to the fore.

PHONOGRAPHISCHE ZEITSCHRIFT

BERLIN W. 30, GERMANY

The oldest and most up-to-date trade paper covering the talking machine line published in the German Language.

PUBLISHED WEEKLY. FOUNDED 1900

Circulates all over the world.

SPECIAL EXPORT NUMBERS appear in four different languages at regular intervals.

Subscriptions for this talking machine publication 10 Marks yearly. Sample copies sent free.

REGARDING THE PROPER HANDLING OF EMPLOYEES.

The Questions of the Training of Talking Machine Salesmen, Their Wages and the Methods of Interesting Them in Their Work Discussed in Interesting and Thoroughly Practical Fashion by Benj. Switky, the Prominent Victor Distributer of New York.

Ninety-five per cent. of the dealers of my acquaintance have more or less trouble with their "help." It is an everpresent source of annoyance and trouble to them, and I have often listened to their really serious complainings that they were either handicapped or caused to suffer financial loss by reason of unsatisfactory help. Therefore it might be well for us to dwell on some of these problems in the hope that a little light may be cast upon them so as to help brighten the dealer's path and make easier the journey to the goal of profit and success.

But first of all, I think it will do more good than harm if we point out to our good friend, Mr. Dealer, that usually he is himself to blame for most of his troubles. If he will accept the responsibility and take upon himself the duty of properly training his help, see to it that they are not underpaid, nor made to work from twelve to fifteen hours a day—if he will treat his help liberally, democratically, and secure their good will and loyalty, he will find himself free from many of the so-called troubles that we hear so much of.

The Result of Low Wages.

To pay poor wages is the greatest extravagance that a man can be guilty of. The dishonesty of an employe is very often the direct result of his being underpaid. I have had men confide in me that they could not do justice to their families and remain loyal to their employers on a weekly salary of \$12 to \$15. This applies particularly to salesmen in the bigger cities, where the cost of decent living is comparatively high.

The slow, sluggish worker can be electrified with energy and fired with ambition by the increase of a dollar or two a week and the promise of another raise just as soon as he shows himself worthy of it. Even the errand boy will give you better service if he is properly paid. He will be less likely to loaf. He will cut out scheming how to use transfers in order to knock down a few nickels a week. He will use the elevated and subway trains instead of wasting precious time travelling long distances on slow-moving trolleys.

It would surprise some of my friends if they knew that their clerks are just as dissatisfied with their jobs as their bosses are dissatisfied with their clerks.

Even as the employer finishes asking my advice whether to retain such and such a clerk, his man confides in me, on the side, that he would like to make a change—that his self-respect revolts at being constantly scolded for trifles; that while the pay is pretty good, still the hours are long, etc.

The Importance of Training.

Training implies directing thought and work and energy along such channels as will lead quickest to the result desired. If you want to cover your front porch with a honeysuckle vine it is not enough to merely stick the seed or the plant into the ground and then wait for it to creep. The proper way is to *train it*. You either tie strings to the different shoots and fasten them to the top of the porch with tacks or you provide a wire net from top to bottom so that your vines will have something to cling to, to wind around and spread upon.

I have heard men say that salesmen, like poets, are born, not made. But for the benefit of the many who cannot show a birth certificate testifying to their salesmanship, I want to say that I do not believe seriously in the foregoing statement. Every man of average intellect, pleasant personality, with an earnest desire to succeed and a willingness to learn, has within him the material necessary for the making of a salesman.

You can train your clerks to be real salesmen if you will but take the time and trouble to do so. You should bring to their attention every available bit of printed matter that bears on the subject of selling. They should read carefully their own trade paper. There are to-day schools of sales-

manship, correspondence schools with class or club representation in most big cities. It will surprise you how mathematically exact is the science of salesmanship as taught by the Sheldon School of Chicago, for instance.

You should teach your salesmen how to approach a prospective customer, how to size him up so as to interest him in the goods. In order that he may talk intelligently about his goods, he should know something about the composition, material, method of manufacture, construction, etc. He should have a fair knowledge of the mechanism of talking machines. I would earnestly advise as many dealers and salesmen as can possibly do so to avail themselves of the courtesy of the several manufacturers and carefully inspect any one of the factories. I am sure that you will return from such a tour of inspection feeling that you have learned a great deal about your own business. You will take greater pride in the industry of which you are a part. You will feel like the Roman who



Benjamin Switky.

proudly boasted: "I am a citizen of no mean country!" How often have I heard customers ask, "What are these records made of?" and the salesman replied, "Hard rubber."

You should urge your clerks to learn to take a motor apart and reassemble it—not necessarily in order to become proficient repairmen, but because a good mechanical knowledge of the motor enables them to talk intelligently when trying to make a sale. If they can impress their hearers with a good selling talk and win their confidence by demonstrating a thorough knowledge of their goods, more sales must result.

Don't wait for your help to pick up knowledge. **TEACH THEM!** You can teach them, in the course of a half-hour's talk, certain bits of knowledge which they might not acquire or stumble across within six months. Point out to them that certain records appeal only to a certain class of music-lovers, that other selections invariably please middle-aged or elderly folks, that another group of records sells very rapidly to foreigners, etc.

You must be constantly alert to train your help. The boy or driver who distributes your packages must be taught to handle the goods carefully or you will incur losses by breakage. The boy who puts away records or who packs the shipments must be trained to do the work carefully and conscientiously. The order clerk must be taught the need of watchfulness to avoid overstocking on the one hand or the loss of sales by being "out of it" by reason of oversight in ordering. Your clever salesman must be taught how to handle three or four customers at one time and to do it thoroughly, without apparent effort, confusion or the loss of any sales.

Interesting Your Employes.

In addition to teaching your employes how to do their work correctly, it is your duty to stimulate interest in their work. I shall relate to you briefly a method which I have used successfully for some

time past, one that has yielded good returns out of all proportion to the expense involved. I make no claim for originality, but will freely confess the idea is merely an adaptation of similar practices made use of in other businesses, usually of larger calibre.

About once a month I invite the entire force, from the manager to the youngest of the boys, to a dinner at some restaurant out in the neighborhood. After an hour or more devoted to chatting, mixing, etc., we all adjourn to the store, where we settle down to the serious business of the evening. I had been careful beforehand to ask each employe to try to bring to the meeting at least one new idea or suggestion of improvement to be discussed in open meeting.

The work of the evening is classified and taken up in the following order: First, the roll is called, and as each responds he is asked whether he has any complaint or grievance to present. If he replies in the affirmative, the matter is threshed out in open meeting and always adjusted to the satisfaction of the complainant. Second, each is invited to present criticisms as to management, whether in his own department or in another department. Third, they are asked to contribute for discussion and possible adoption suggestions looking to improve the service, lighten the work, eliminate unnecessary waste motion in the handling of the work, economizing time and labor, minimizing expenses, etc.

Just try it once and you will be as greatly and as agreeably surprised as I was. You will get valuable tips from the errand boy. The shipping clerk will point out to you how to perfect his department. Your stock boy will suggest how to cut down the time ordinarily required to put away stock or to pick out an order. It may cost some money at first to adopt many of their suggestions, but in the long run you profit by them.

But more important than all is the fact that you have induced your help to think seriously about their work; they find pleasure in trying to bring their efficiency nearer to the 100 per cent. mark; they actually give you more than you are paying them for and do it cheerfully because they feel flattered that they should be taken into the chief's counsels.

Then top off the evening's program with an instructive talk on salesmanship, inviting free discussion of the comparative merits and demerits of competitive lines. Let them relate how certain difficult sales were clinched, etc. They will learn from you; they will learn from one another.

If you are interested in the efficiency of your force—which you certainly must be if you are to receive full measure of success—you must be on the job all the time training and teaching.

NOVEL WANAMAKER RECITALS.

Victrola Furnishes the Voices of Living Characters Who Appear Costumed as in Actual Life—Attract Large and Appreciative Crowds—John Wanamaker a Victrola Enthusiast.

The Victrola section of John Wanamaker's New York store presented during Christmas week, at two performances daily in the store's handsome auditorium, four acts of living tableaux with characters in costume who pantomime the acting and singing of the principle arias from the opera, "Aida," assisted by the Victrola. These daily performances attracted crowded houses, and thereby increased popularity of the Victrola.

The principal characters of the opera all appeared before the audience in actual life, but instead of rendering their respective selections as they would on the operatic stage, a Victrola furnished the actual voices of Caruso, Gadschi, Destinn and the other famous stars. Accompanied by the pipe-organ and piano.

It is interesting to note, by the way, that John Wanamaker is personally a Victrola enthusiast, and owns in his handsome home, a Victrola X, finished in Japanese lacquer, a product of the Wanamaker Victrola department. The Victrola is one of the most artistic instruments ever introduced for use in a private home.



The New Columbia Advertising Record is proving itself the ablest collector of new names and new business that the dealer ever found. *It breaks the ice.*



(Write for "Music Money," a book "full of meat" for those dealers interested in quick and frequent turnover of capital.)

Columbia Graphophone Company
Woolworth Building, New York

RETAIL STOCKS ARE LOW IN SAN FRANCISCO.

Immense Holiday Business in the City and Surrounding Territory Made Placing of Large Orders a Necessity the Opening of Year—Record and Machine Business Heaviest Coast Trade Has Ever Enjoyed—Sherman Clay & Co. Expand—News of the Month.

(Special to The Talking Machine World.)

SAN FRANCISCO, CAL., January 9.—Talking machine interests here, whether Victor, Columbia or Edison, either wholesale or retail, were well satisfied with holiday business. The distributors of each line supplied more goods than ever before and the retail trade showed a decided gain over previous seasons, notwithstanding the very stormy weather which prevailed the last few shopping days before Christmas, and other adverse conditions which are held responsible for disappointments in some other lines of business catering to holiday trade. In San Francisco retail stocks are well cleaned up and all reports from the country districts indicate that dealers did not overstock by any means. That stocks were much depleted in many instances is shown by the orders received by the distributors here immediately after Christmas. A satisfactory feature of this holiday business was the tendency toward the higher priced machines, and the enormous demand for records. Record business for December was the heaviest the Coast trade has ever enjoyed, and it is keeping up exceedingly well since the holidays. Prospects for 1914 are considered very encouraging by the local trade.

W. S. Gray, coast manager for the Columbia Graphophone Co., says December was the biggest month this office has ever had, and he is now formulating plans for a very active campaign in this section for the ensuing year. He says he is going in especially hard after record business. F. Anglemier, manager of the wholesale department at the local Columbia warerooms, says they managed to fill orders in pretty good shape with the exception of some late rush ones, but a few days before Christmas they were left without a half-dozen machines on the floor. Favorite and Leader machines were big factors in the fall trade, but they did not interfere with the sale of the higher priced types as they were in good demand also. A number of the grand Grafanolas were sent out in December.

At these Columbia headquarters a steady increase is noted in the demand for dictating machines. A large shipment was sent out on the steamer "Persia" which sailed a few days after Christmas for Manila, where Mr. Anglemier says there is a considerable demand developing. The installation of machines for the exposition occupied particular attention here the past month.

Manager J. S. Bayley, of the local branch of Babson Bros., says December business was beyond expectations. Considering that this was the first year for the Edison disc machine, he says the results with it were very gratifying indeed. He entirely sold out types of machines which were in greater demand than he had anticipated. Among them were the \$80 machines, \$250 mahogany disc types and \$150 disc models. Notwithstanding the absorbing interest shown in the new disc product, cylinder business, according to Mr. Bayley, was

the best in a long time. He regards the outlook very favorable for a big 1914.

L. S. Sherman, of Sherman, Clay & Co., whose Victor business runs into a million dollars a year, says that each year they have been distributing Victor products they have been able to get more goods, but that the demand has shown a corresponding increase so they still have some difficulty in supplying the needs of their customers. Holiday business was especially gratifying here in San Francisco. The tenth floor of the building was hardly ready for permanent occupancy before the holidays, so it was used as a store room for Victor Victrolas calling for holiday delivery, and before they began to move out, a large section of the floor space was covered. Mr. Sherman says the popularity of the new tango dances here has undoubtedly stimulated a particular demand for Victor Victrolas. A great many people are taking lessons and find the Victor a great aid in their home practise. The demand for the tango records bears out the statement of the influence of the new dances on the sale of machines.

P. H. Beck, of the Kohler & Chase talking machine department, is very well satisfied with holiday business, the week just preceding Christmas being especially heavy, and bringing the record for December up to a large figure.

A. R. Pommer, proprietor of the Pacific Phonograph Co., whose enthusiasm for Edison products has been largely influential in the rapid progress made in the favorable introduction of the new disc line in this section, is more than ever optimistic over the future outlook for the line since the big holiday rush, which his company enjoyed. While he was able to supply his customers in fairly good shape, owing to the large reserve stock which he had accumulated in anticipation of a shortage at holiday time, his warerooms were practically cleaned out on Christmas Eve, especially of the high-priced machines. He says the tendency of this holiday demand was toward the better products. He was heavily stocked with the high-priced machines, but was entirely sold out of \$250 styles, for instance, while he could still make deliveries of the \$60 types. J. E. McCracken, traveler for the Pacific company, was at headquarters here for a few days at holiday time, but has since returned to Seattle, and from there will proceed to other points in the Northwest.

The coast trade received a visit recently from F. K. Dolbeer, sales manager for Thos. A. Edison, Inc. While in San Francisco he made his headquarters with the Pacific Phonograph Co., and from here went North to Portland and Seattle.

Holiday business in the Columbia department at the Emporium was very gratifying to the management, as evidenced by the fact that they were obliged to provide extra accommodations for demonstration purposes in December. To this end the rooms formerly used for player-piano demonstra-

tions were placed temporarily at the disposal of the talking machine section, and besides the removal of the sheet music department to other floor space, leaves more space for talking machines. Mr. Morgan says the demand for machines here covered a wide range. The Favorite and Leader had splendid call, but the more expensive styles moved well also. Record business as well as machine sales for December was by far the best month this department has had.

Since the duck season opened Peter Bacigalupi, Jr., manager of the talking machine department of Peter Bacagalupi & Sons, has been spending considerable time up at his hunting preserve near San Rafael.

A CHRISTMAS TRAGEDY.

Are we to hold ragtime revues and other hustling forms of entertainment responsible for the following tragedy?

A music hall artist who used to tour the provinces with a flock of performing ducks, found manager no longer willing to book his sedate show. After he had been resting for some time he received a telegram asking him to open on the following Monday at a variety theater in northern New England. In reply he wired:

"Regret cannot come. Have eaten the Act."

**Simplex
Automatic
Start and Stop
Device**
LISTED BY 95%
OF VICTOR JOBBERS
WHY?

STANDARD GRAMOPHONE APPLIANCE CO.
173 Lafayette Street, New York, N. Y.

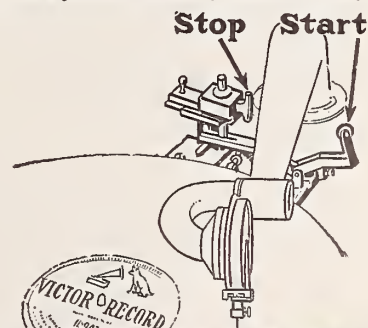

¶ Pioneers in selling
VICTROLAS
today our system is far
better than the ordinary
methods.

There is real help all along the line for live dealers in getting in touch with us. Especially do we aim to assist those dealers who are desirous of achieving supremacy in their local territory.

Three things you find here:

The largest stocks.

The quickest service.

The most courteous attention.

A request from a dealer will result in placing his name at once on our rapid-fire mailing list

World's Largest
MUSIC HOUSE

Lyon & Healy

Chicago

FROM OUR CHICAGO HEADQUARTERS

ROOM 806, NO. 37 SOUTH WABASH AVENUE, E. P. VAN HARLINGEN, MANAGER.

(Special to The Talking Machine World.)

CHICAGO, ILL., January 10.—The year closed in a blaze of glory so far as the Chicago talking machine trade was concerned. December was away ahead of the corresponding month of 1912 according to both the local jobbers and leading retailers. It must have been a cracking good month too, with the country trade, as not only were orders placed before the holidays been left to stand with practically no cancelations and mighty little revision, but new orders for machines have been coming in since the first of the year, speaking eloquently of depleted stocks and a lively current trade.

Another feature of the trade which tells of the wonderful progress of the business is that there has been a shortage of records, notwithstanding the big preparations made in this regard by the leading companies. Shipments are coming on in better shape and they are certainly needed, as January and February are always big record months, as this is the period when the recipients of talking machines for holiday gifts come into the market in the first flush of their enthusiasm.

Everybody is looking forward to a good year in 1914, and certainly with such a remarkable record for a year, during which general business conditions have not been of the brightest, still greater things may legitimately be expected when the financial and industrial clouds which have hung over us for so long give indication of dispersing.

Entertains Sales Force.

L. C. Wiswell, manager of the talking machine department of Lyon & Healy gave a dinner to the wholesale selling forces of the department at the Union restaurant on Tuesday evening. It was very informal, everybody participating in the talk-fest. Good stories were told, some pertinent to the business and some impertinent, and there was also a discussion of the trade situation and optimistic planning for the year's campaign. After dinner the balance of the enjoyable evening was spent in witnessing the performance of "The Honeymoon Express," at the Garrick. Those present, besides Mr. Wiswell, were: J. E. Meagher, Wisconsin traveler; J. B. Ryde, Illinois; E. P. Bliss, Indiana and Michigan; Paul Rocah, city wholesale; A. Scannell, inside wholesale salesman; A. Agnew, wholesale correspondent.

A. D. Geissler Reviews Trade.

Arthur D. Geissler, general manager of the Talking Machine Co., of Chicago and of the New York Talking Machine Co., arrived this week for a stay of a fortnight or more. He was very enthusiastic over the volume of business which has been done

in both cities and the outlook for the coming year.

"At a rough estimate, I should say that the Victor business has increased, at the most conservative figures, 75 per cent. the past year," said Mr. Geissler. It is a fact that the New York Talking Machine Co., finding a shortage on certain types wired practically every distributor in the East offering to buy any of those machines that they could spare at dealers' prices.

As a result, we got in \$10,000 worth of goods the day before Christmas, on which we made no profit, but which helped us to make good on our efforts to give our dealers the very best service in our power. The same thing occurred with the Talking Machine Co. here in Chicago, with the result of materially relieving the situation. Fortunately we have had ample stocks of the \$200 machines, and in many instance dealers have met a shortage on the \$150 machines by raising their customers to the \$200 machines, and the \$75 machines by raising them to the \$100 machines. Not only has the machine business been great, but sales of records have been most remarkable. Dealers, who in past years, have been ordering one, two and three of a selection, have ordered ten, fifteen and twenty-five, and have sold them judging from the orders that have been flooding in on us since the first of the year. Every indication certainly points to a big year in 1914.

Splendid Edison Sales.

C. E. Goodwin, general manager for the Phonograph Co., the Edison distributors, waxed enthusiastic over the December trade. "I don't ask you to believe my mere unsupported statement for it, but I just want you to go over these order books of our retail department. They show fully 80 per cent. of the sales to have been of the \$250 machines. Strange as it may seem," Mr. Goodwin remarked, "our wholesale business has shown a very similar record. The Edison disc is far eclipsing the anticipation entertained for it by the manufacturers and the distributors, and goodness knows they are optimistic enough."

"Low and Grim."

The youngest purchaser of the season at "The Shop" was a little lady of some ten years, who purchased a Style XI Victrola for her "papa," and paid for it in cash. She said she had been saving up for a long time, had decided what records she wanted, and handed Miss Tischler a list of them. The list included: "Low and Grim," "Med and Tation from This; "Heilige Nacht, Stille Genacht" and "Breakfast in Bed," by Harry Louder. Also

a band record by "Susie." Miss Tischler called for help and eventually managed to figure out "Lohengrin," and "Meditation," from Thais. All of which reminded C. L. Davidson of the woman who bought "Home to Our Mountains" from "Il Trovatore" and turned to her husband who entered the shop a few minutes later, saying: "Oh, Harry! I have just bought the grandest record! It's from 'Trovatore'—'Back to the Woods.'"

Columbia Reports.

W. C. Fuhri, district manager for the Columbia Graphophone Co., says that all the branch houses in the extensive Western and Southern territory under his jurisdiction have made a marked improvement in business the past year, and that December was in the record-breaking class—this notwithstanding the supply of goods was not equal to the demand.

C. F. Baer, manager of the Chicago office, reports that the dealers in this territory did a really phenomenal business. While the December business greatly surpassed that of 1912, and in fact of any year, a number of orders were carried over and they are sticking. "We recently got in the new \$200 DeLuxe and the new \$175 Nonpareil," continued he, "and dealers are going simply wild over them and are reordering at a high rate of speed. Locally our retail was immense, and this in spite of the removal to new quarters right in the midst of the rush season."

The Dictaphone business of the Chicago office is said to have practically doubled during the year.

At Lyon & Healy's.

L. C. Wiswell, manager of the talking machine department, said: "December and the year were record-breakers. The big business was in machines from \$100 up. Just as many \$200 machines were sold, in fact more, than ever, while more than four times of the \$100 machines were sold than any machine we have ever had to sell at that price."

"The retail business of Lyon & Healy was something immense as usual. There were several days when the retail machine sales mounted upwards of \$10,000, and on one memorable day just before Christmas 175 Victrolas of various types were sold at retail."

At Wurlitzer's.

F. A. Siemon, assistant manager of the Chicago house of the Rudolph Wurlitzer Co.: "It was a mighty good year. December was a wonder. Why, in our retail we kept our big special Victrola truck going all day Christmas delivering \$200 machines, (Continued on page 40.)"

The Practical Fibre Needle Cutter—THE WADE

The WADE embodies the right principle, worked out through long experience. It is simple, durable and accurate. It trims the needle at an angle resulting in the best tone.

The WADE cutters are made of the best steel and are absolutely guaranteed.

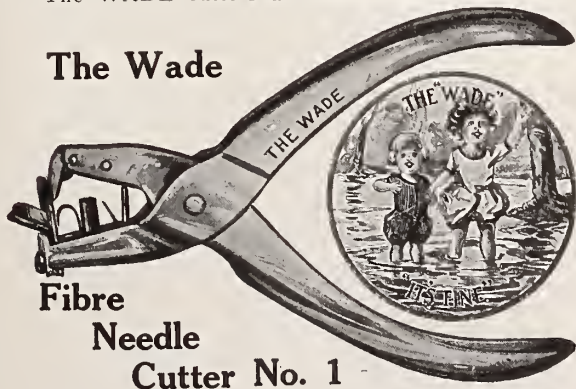

The Wade
Fibre
Needle
Cutter No. 1

The WADE is the most economical cutter. It has a self-acting stop, which prevents waste and enables one to get from 12 to 15 perfect playing points.

No. 1 is a very popular cutter which has given excellent service. No. 2 has a double action, making it especially easy to operate and affording the most powerful cut of any tool made.

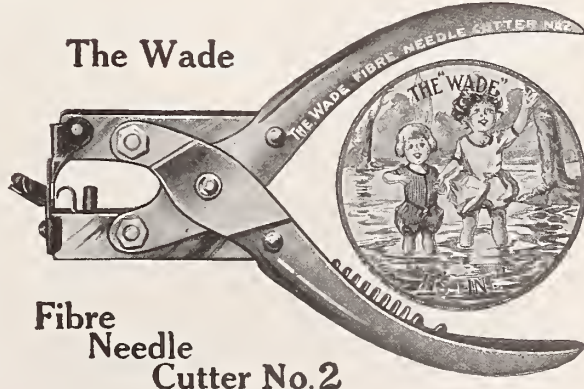

The Wade
Fibre
Needle
Cutter No. 2

RETAIL PRICES—No. 1, \$1.50; No. 2, \$2.00

Order from your regular Distributor—we sell to Jobbers only

WADE & WADE,

3807 Lake Ave.
PHONE, DOUGLAS 8108
CHICAGO, ILL.

FROM OUR CHICAGO HEADQUARTERS—(Continued from page 39).

and we have reports of similar overtime activity on the part of many of our out-of-town dealers. The best thing about it is that the year is starting out with a vim and with good orders for both machines and records. You simply cannot stop this marvelous talking machine business."

Have Good Exhibit.

Schram Bros., manufacturers of talking machine record, music and music roll cabinets, this city, have a most interesting exhibit of their extensive line at the furniture manufacturers exhibition building at 1317-1319 Michigan avenue.

Cameron Takes Furlough.

L. K. Cameron, manager of the retail talking machine department at the Chicago house of the Rudolph Wurlitzer Co., has been compelled to take an indefinite leave of absence on account of a nervous breakdown. He left this week for Tucson, Arizona, where he has relatives, and will indulge in wild Western activities, shooting, fishing and riding. His friends are eagerly awaiting photos, showing him in sombrero, gauntlets and a few other articles of apparel and with a bunch of Indian scalps. Mr. Cameron is one of the best posted and most popular members of the local talker trade, and his many friends sincerely trust that he will be speedily restored to his normal health. In the meantime, F. A. Siemon, assistant manager of the house, will give the retail department his direct supervision in addition to his other duties.

Klingsor Progress.

In a chat with *The World*, Louis Schram, treasurer and general manager of the Klingsor Talking Machine Co. of America, said: "Everything indicates that we will be in a position to commence taking orders for our machines by February 1. Theodore Isaacs, our president, returned from Europe recently, where he made arrangements with the Klingsor Talking Machine Co., of Germany, whose works are at Hannau, for the construction of sound boards exactly fitting our American styles. The sound board is the key to the wonderful tone production of the Klingsor machines, and this move assures our getting the remarkable reproduction in the machines we make here that has made the European Klingsor product famous."

"Lightning Tom" Dead.

Thomas W. Gray, well-known among Lyon & Healy customers as "Lightning Tom" because of his remarkable proficiency as an order filler, died suddenly on Tuesday of this week of organic heart trouble. He had been with the talking machine department of Lyon & Healy for eight years, first as order filler and later in charge of stock. He was a great favorite in the house and his death is keenly regretted. He was forty-three years of age and leaves a wife and a little daughter of thirteen. L. C. Wiswell took entire charge of the arrangements for the funeral, which was held at the house. Manager B. B. Blackman and Miss Lessing, of the record department, sang. The pallbearers were Messrs. Fitzgerald, Mautz, Nuppenau, Burns and Gotch, Mr. Gray's associates in the order and stock departments, and John Otto, of the retail sales department. The burial was at Oak Ridge.

Remembered Their Dealers.

The Talking Machine Co. sent to each of the dealers with whom they do business a handsome gray leather order book as a Christmas present, with the name of the dealer embossed on the cover. The company has received many expressions of appreciation from the recipients.

He Was Charmed.

C. F. Baer, manager of the Chicago office of the Columbia Graphophone Co., received many Christmas presents no doubt, but none that he values more than a beautiful gold and diamond bestudded watch charm, emblematical of the Knights Templar of which he is a member. It was accompanied by a letter expressing some views not altogether derogatory to Mr. Baer. "Presented by employes of the Columbia Graphophone Co., Christmas, 1913," was the legend engraved on the beautiful memento.

Will Visit Iowa Trade.

O. H. Radix, who has had charge of the order

department of the Chicago office of the Columbia Graphophone Co., will travel for them in the State of Iowa hereafter, succeeding E. W. Graham. J. Tucker, who has been in charge of the return goods department, succeeds Mr. Radix in the order department. Both men have been given well-deserved promotions.

New Permanent Needle.

The Soler Graphophone Needle Co., of this city, who has been making a special steel needle for some time, is now putting on the market a diamond point needle for disc records, which is said to be indestructible, will last a lifetime and will not injure the records. It retails for \$3. The diamond point needle, Mr. Soler says, is covered by the patents covering his old diamond process needle.

Big Salter December.

Last year was not only a notable one with the Salter Mfg. Co., but December was the biggest month in the history of the business, according to President John F. Mortenson. The year has opened up with an encouraging volume of business from dealers whose stocks were cleaned out by the holiday rush and who are preparing for a good demand from those who received gifts of "cabinetless" machines, and who will therefore soon be on the market for means for storing their records.

Business Good, Prospects Fine.

S. O. Wade, of Wade & Wade, and the inventor of the excellent fibre needle cutter bearing his name, is highly satisfied with what 1913 brought him in the way of business. It witnessed a great increase in the number of jobbers of the Wade cutter and practically a doubling in the volume of sales. He has received some unusually large stock orders since 1914 became a fact.

Visitors and Personals.

Among the visitors the past week or so were the following: Mr. Schmidt, of the Schmidt Music House, Muscatine, Ia.; W. H. Aton, Baraboo and Madison, Wis.; E. H. Jackson, proprietor of the Talking Machine Shop, Rockford, Ill.; Mr. Kissler, La Porte, Ind.; both members of the firm of Manor Bros., Hebron, Ill.; Charles Heiman, Sturgis, Mich.; C. S. Sinclair, Dundee, Ill.; M. M. Marin, Grand Rapids, Mich.

Edward Selbman, proprietor of the Northwestern Talking Machine Exchange, 2033 Milwaukee avenue, has bought out the Victrola department of the Boller Piano Co., 2168 Milwaukee avenue.

F. K. Dolbeer, general sales manager for Thomas A. Edison, Inc., spent Sunday recently with C. E. Goodwin, the manager of the Phonograph Co., local Edison distributors. He was on his way to Minneapolis, Minn.

Theodore Winfield succeeds the late Thomas Gray in charge of the talking machine stock at Lyon & Healy's. He has been in the department for some years.

Miss Marion Cockrell is the latest addition to the sales forces of the Talking Machine Shops.

W. H. Sajewski, dealer at 1011 Milwaukee avenue, has bought considerable property at Lakeview, Mich., and early this spring will build a dancing pavilion and store as well as a commodious summer house. Mr. Sajewski has built up a very profitable trade in foreign records, as well as in English, and does a large mail order business.

Samuel Glick, son of A. Glick, dealer at 2100 W. Division street, has decided not to follow in the footsteps of his father but will take up a course of study soon at the Michigan Agricultural College, with the ultimate intention of entering the Government's employ as an expert agriculturist.

A. C. Burik, floor salesman for the Talking Machine Co., has returned from a vacation spent with his parents at Madison, Wis.

A. G. Kunde, the well-known Columbia dealer of Milwaukee, was in town a few days ago placing stock replenishing orders. During the holidays he cleaned out practically every machine on the floor, and his stock was no small one at that.

W. W. Parsons, district manager for the Dictaphone department of the Columbia Graphophone Co., has been made a member of the bowling com-

mittee of the Illinois Athletic Association. He is an expert. The club's official organ printed the photograph of Dictation Parsons, the soubriquet he is given by his fellow members, and gave him a nice little "send off."

Don C. Preston, George Cheattle and Elmer Ditmer, all travelers for the Talking Machine Co., spent part of December at headquarters, leaving for their respective homes for the holidays.

Roy Keith, sales manager for the Talking Machine Co., is again at his desk after a week's confinement to his home with a severe attack of tonsillitis.

Edwin C. Barnes, of E. C. Barnes & Bros., Chicago representatives for the Edison dictation machines, has been made a member of the music trades committee of the Chicago Association of Commerce.

George P. Metzger, advertising counsel for the Columbia Graphophone Co., spent a day or two at the Chicago office recently and expressed himself as most highly pleased with the beautiful new home on Michigan avenue. He was on a trip which will take him to the Coast. He will visit the various Columbia stores on the way.

J. W. Roose, manager of the Indianapolis branch of the Columbia Co., was a visitor to the Chicago office this week.

H. L. Willson, assistant to General Manager Lyle, is expected here in a day or two in the course of a trip among some of the Western branch offices.

J. D. Westervelt, supervisor of agencies of the Columbia Dictaphone department, spent a couple of days in Chicago recently.

L. C. Wiswell, who is chairman of the committee on arrangements for the next annual convention of the Talking Machine Jobbers' Association, leaves next week for Pittsburgh to consult with President J. C. Roush.

W. C. Fuhri, district manager for the Columbia Graphophone Co., will leave next week on a visit to headquarters in New York.

LYON & HEALY SIGN LEASE

On Tuesday for New Ten-Story Building to Be Erected at the Northeast Corner of Jackson Boulevard and Wabash Avenue, Chicago.

(Special to *The Talking Machine World*.)

CHICAGO, ILL., January 9.—Lyon & Healy celebrated the passing of the year and the firm's fiftieth anniversary by making final arrangements whereby it secures for a term of twenty-six years a lease on a ten-story building to be erected at the northeast corner of Jackson Boulevard and Wabash avenue, where there now stands the Wellington Hotel, one of the landmarks of the city and for many years a leading hostelry.

Negotiations have been pending for some time, but it was not until yesterday that the deal was closed. The lease was made to Lyon & Healy by Mrs. Carrie L. Munn, of Washington, D. C. The term is twenty-six years at an annual ground rent of \$60,000 for the first five years, \$70,000 for the next five and \$80,000 for the rest of the term.

Mrs. Munn is to construct a ten-story building after plans by Marshall & Fox, for which the firm is to pay as rent 10 per cent. on the cost of the building up to \$500,000. The additional cost of construction is to be paid by the firm. The removal of the present hotel building will be begun on May 1, 1915, following which the new building will be pushed to rapid completion.

The area of the site is ninety-six feet on Wabash avenue and 171 on Jackson Boulevard.

The average annual ground rent is \$74,000, which, capitalized on a 4 per cent. basis, gives a leasing value of \$1,850,000, which is at the rate of \$19,720 a front foot for the Wabash avenue frontage and \$112 a square foot. The average annual rent which Lyon & Healy will pay net to the lessor for both ground and building is \$124,000. They also will have a large capital investment in the building. The board of review valued the property at \$1,451,883, of which \$1,411,883 is in the land and \$40,000 in the building.

THE GROUND HASN'T BEEN SCRATCHED



**Nearly 100,000,000 People in This Country
Please Figure What a Small Proportion of Them Own Victors**

Then Figure the Possibilities of the Victor as
the One Musical Gift the **WHOLE** Family
Can Enjoy. Get at the Friends of These
People You Sold Machines to—Prove the
Opportunity for Increased Record Sales.

1913 Doubled the Victor Business
1914 Has a Better Chance Than Last Year

Every Machine Sold is a Salesman—an Outlet
for More Records. Our Dealers said we Made
Good during the Christmas Rush in spite of the
Shortage. This Year Give Us Your Business.

THE TALKING MACHINE COMPANY
12 No. Michigan Ave., Chicago.



ECLIPSE PHONOGRAPH COMPANY

A. W. TOENNIES & SON

203 Washington Street, Hoboken, N. J.

JOBBER OF

Edison Disc and Cylinder Phonographs Exclusively

Dealers of New York and New Jersey
Write for terms and discounts.



EDISON HUSTLER IN FALL RIVER.

Wilmot's Establishment a Center of Activity for Purchasers of Edison Phonographs and Records During the Holiday Season.

(Special to The Talking Machine World.)

FALL RIVER, MASS., January 9.—The name of Wilmot in this city stands for a good deal among the music lovers, as many heads of households and members of their families recall with pleasure their visits to this well-known establishment. Wil-

BIG RESULTS IN LOS ANGELES

Of Campaign for Holiday Business—Talking Machine Dealers, Without Exception, Report Big Advance in Trade for the Year, Covering All Leading Makes of Machines and Records.

(Special to The Talking Machine World.)

LOS ANGELES, Cal., January 3.—The most surprising results in the talking machine trade for the past month marks the close of the year, which stands as the banner year in the history of the trade. And not only a few, but all dealers have set a new record for the coming year.

Barker Bros. have very recently added the new Edison disc line to the talking machine department. Geo. S. Barnes, department manager, states that a great amount of the sales has been of the Edison disc, which would have been trade lost if the line was not handled.

H. B. Hinman, manager of the talking machine department of the Gray, Maw, Thompson Co., San Diego, Cal., was in Los Angeles for a few days, and reports that the department more than doubled its amount of sales over the previous year.

The Wiley B. Allen Co., of this city, closed the year with the most satisfactory results in their talking machine department. Manager R. E. Wolfinger says that never before had they experienced such a strenuous time supplying the needs of the purchasers. The gratifying feature of their holiday trade was the large amount of cash sales, which comprised fully three-fourths of the gross sales of the department.

The Geo. J. Birkel Co. also experienced an unusually good season's business in its large Victor department, of which A. Graham Cook is manager.

The Southern California Music Co., Edison jobbers, has reaped an abundant harvest in the Edison disc phonographs. Their dealers have been enthused with the Edison disc line. They did a wonderful retail trade also in the Victor and Columbia lines.

E. Holland, proprietor of the Vernon Music Co., reports a good business for the season in both Columbia and Edison lines.

Schireson Bros.' talking machine trade has been most satisfactory. They did a big business in Italian, French and Chinese records.

Chas. S. Ruggles, manager of the Sherman Clay & Co. store, in this city, says the year just closed was the biggest and best in the history of this

branch. The sales have been principally in the higher priced Victrolas.

The J. B. Brown Music Co. has been making wonderful strides toward success in selling the Edison disc. V. B. Chatten, who is in charge of the talking machine department, states that each salesman has been taxed to his utmost capacity within the past few weeks. R. E. Daynes, a salesman, has put through a number of very fine sales recently. He sold the first Edison disc Louis XVI. model A 400 in this city.

I. H. Andrews is enthusiastic over sales conditions, stating that Victrolas XIV. and XVI. were ready sellers.

Miss Jordan, who has recently been sent to the coast by the educational department of the Victor Talking Machine Co., is in Los Angeles for a short time speaking and lecturing before the faculty of schools, colleges and institutes in behalf of the musical education in these institutions through the medium of the Victor. Miss Jordan's Pacific Coast headquarters are now in Berkeley, Cal.

COMMERCIAL FAILURES FOR 1913.

Considerable Expansion in the Country's Business Mortality as Compared with 1912.

Preliminary statistics of commercial failures in the United States during 1913, as reported by R. G. Dun & Co., indicate a considerable expansion in the country's business mortality as compared with the preceding year. Total insolvencies numbered 15,847 and involved \$262,639,008 of defaulted indebtedness, against 15,452 suspensions in 1912, when the liabilities were \$203,117,391. As is customary, the heaviest losses of the year occurred in the opening quarter, while the second three months made much the best exhibit, both in respect to the number of failures and the sum of money owed.

In the following table failure returns for the last two years are compared by quarters, figures for the last few days of December being estimated:

	1913		1912	
	No.	Liabilities.	No.	Liabilities.
First quarter	4,458	\$76,832,277	4,828	\$63,012,323
Second quarter	3,405	56,076,784	3,489	44,999,900
Third quarter	3,549	63,837,315	3,499	45,532,137
Fourth quarter	4,435	65,892,632	3,446	45,150,731
Total, year	15,847	\$262,639,008	15,262	\$198,695,091

LIGHT AND THE WINDOW DISPLAY.

Dark blue reflects 0½ per cent. of the light falling upon it.

Dark green, about 10 per cent.

Pale red, more than 16 per cent.

Dark yellow, 20 per cent.

Pale blue, 20 per cent.

Pale yellow, 40 per cent.

Pale green, 46½ per cent.

Pale orange, nearly 55 per cent.

And pale white, 70 per cent.

A window finished in light oak can be lighted with much less wattage than a window finished in dark mahogany; likewise, a window in which white goods are displayed.—American Architect.



Shipping Edison Disc Phonographs to Customers in Fall River.

mot's is the recognized headquarters for the Edison goods, and the accompanying picture shows twelve of the large and expensive Edison disc machines about to be shipped from the store to customers. Mr. Wilmot, the head of the house, has had a business experience covering seventeen years, so that he is pretty well acquainted with the talking machine proposition, and therefore knows how to handle his growing trade. He is president of the Fall River Men's Business Association and is one of the best "boosters" that Fall River has. When it comes to exploiting the advantages of his city, Mr. Wilmot is frequently called upon as a speaker at public gatherings.

PRAISE FOR NEW RECORD CATALOG.

The recently issued record catalog sent out to the trade by the Columbia Graphophone Co. has been the subject of much praise and commendation. The many distinctive innovations embodied in the new book, and the maximum of convenience and ease with which the dealer can consult the new catalog, have all been commented on in letters received at the executive offices during the past few weeks. The compilation of this new catalog was a work of many months and was under the direction of G. C. Jell, head of the Columbia record department, whose ideas as to record catalog production are exemplified in the new book. It is indeed a tribute to the unceasing efforts of Mr. Jell that his book is so keenly appreciated.



If you have missed the Columbia profits during the last season, you must have done it unknowingly. If you miss them this coming season, the amount of them will make a long column on your debit page.



(Write for "Music Money," a book "full of meat" for those dealers interested in quick and frequent turnover of capital.)

Columbia Graphophone Company
Woolworth Building, New York

THE TRADE SITUATION IN PHILADELPHIA.

Trade for December Surpassed All Expectations, Being Almost a Third Larger Than It Was Last Year—Dealers Most Optimistic Regarding the General Outlook for 1914—Dealers, Without Exception, Exceedingly Well Pleased with the General Situation.

(Special to The Talking Machine World.)

PHILADELPHIA, PA., January 8.—The trade in talking machines in Philadelphia continued very heavy up to the very end of the year. It surpassed all expectations for the month of December, and was almost a third larger than it was last year, and one feature about it was the great number of high-priced machines that were sold. Every year this seems to be more the rule. Purchasers are no longer satisfied with the cheap machine, for they do not look upon it as a toy or as an amusement, but take the more serious view of it as an educator, and, to get the very best results and find the most thorough enjoyment, nothing under a fifty-dollar machine will suffice. The machines that were sold this Christmas season were those that range in price from \$50 to \$150, and while the popular tango records have had an immense sale for holiday buying the majority of the records were classics—at least those which were given away for presents.

Optimistic View of 1914 Prospects.

As to the future, all the dealers are taking an optimistic view and believe that 1914 is going to far surpass the year just closed, and they are laying plans accordingly. Most of the stores have found their stock about reduced to nothing; they are just finishing up the taking of the account of stock, and then they will order heavily to stock themselves for what they believe is going to be a very excellent spring and summer trade.

New Association Making Some Progress.

There is nothing new in the dealers' organization that was launched early in the fall, other than that the projectors think that now that the busy season is over they will be able to get the men interested and hope to have all of them sign the agreement the feature of which is the charging of interest on all credit sales. There are only two or three holding out. One of the amusing incidents is that two of the large department stores are holding out in their signing one before the other, and some device is being planned to overcome this. If the paper is taken to one store they say they will sign as soon as the other, and vice versa. Now the plan is to have them both sign at the same time, and it has been suggested that the two signees shall be placed at a desk at a certain hour of the day, with their secretaries in telephonic communication, and at a given signal both firms sign. It is hoped that the matter will be brought out in some way, for the organizers of the association are very anxious that something shall be done.

Who Are the Representative Dealers?

There is considerable haggling as to what is meant by "representative dealers," for they are the only ones who are expected to sign, and it is a question that will be hard to decide as to how many machines a man must sell before he is placed in that class. There is going to be considerable caste

in this association when it is organized, and yet it would be impossible to get every one to sign.

Victor Co. Comes to Assistance of Dealers.

The Victor Co. is coming in for great praise at the way it helped out the Philadelphia dealers this year. They did everything in their power both in the way of getting out machines as well as records, and the Camden factory was kept employed both day and night. At times they were swamped almost beyond extrication, but they managed to get out, and no one will begrudge them a rest, no matter how much they may desire.

Good Report from Weymann & Sons.

Harry Weymann, who is the manager of the talking machine department as well as the wholesale department for the small goods made by H. A. Weymann & Sons, says that he never saw or expected to see anything like the holiday business in talking machines and records. He says at their their house the last week in December was equal to the entire month of the previous year.

Close Important Deals.

The Keen-o-Phone Co. reports that it had an excellent Christmas business. It entered into a couple of deals just before the end of the month which are going to give them an output of at least 3,500 machines, which will no doubt put the company on a dividend-paying basis. They expect to shortly place a new style machine on the market.

Talking Machine Co. to Move.

The Talking Machine Co., whose leading store is on Broad street below Sansom, and who have three stores at present, is looking for several new locations, and before spring it expects to have two more stores established, and maybe a third, if the proper place can be found.

No Talker Store in Cunningham Building.

There was a report that a talking machine firm would move to the Cunningham Piano Co.'s building, opposite Wanamaker's, but this statement is false, at least at the present writing. It would be an excellent location for such a business, but the rent demanded in that location would eat well into profits.

Heavy Columbia Business Reported.

W. L. Eckhardt, of the Pennsylvania Talking Machine Co., is most jubilant over his year's work, especially the December business. No comparison could be made with their holiday trade this year and last. Beginning December 1 Mr. Eckhardt set out figures for his December business, that he thought were almost prohibitive to expect, but along about the middle of the month he began to see that he would have to discount them by at least 5 per cent., and by the end of the month his sales had run away beyond his fondest expectations. The very fine automobile truck which they recently secured has helped them out very nicely in their rush deliveries.

During 1913 the Pennsylvania Talking Machine

Co. opened about 200 new accounts, which is going some, and they have prospects of very shortly announcing the Columbia in one of the most desirable places in the city, for which they are about closing a deal. They have also closed a number of important deals in the Dictaphone, and every indication is that this year will be even greater than the last.

Lit Bros. Department Makes Record.

Manager Sternberger, of the piano and talking machine departments of Lit Bros., says they have just gone through the biggest holiday business they have ever had. They will make some big changes in the department early in the new year as to sound rooms, fixtures, etc.

OUTLOOK VERY ENCOURAGING.

Says C. R. Ely, Road Ambassador for the Columbia Co., Who Just Reached New York After Extensive Trip—Manufacturers' Co-operative Work Pleases Dealers.

Clifford R. Ely, the live-wire road ambassador for the Columbia Graphophone Co., arrived in



C. R. Ely.

New York this week after an extended trip through the country, and will spend some time in the East before leaving on his annual country-wide tour. Incidentally, Mr. Ely spent but five weeks at his home in Philadelphia throughout the entire year of 1913.

"Business conditions throughout the country are somewhat unsettled, but the outlook is very encouraging," stated Mr. Ely in a chat with The World. "The dealers are optimistic in their predictions for the coming year, and the talking machine business as a whole is very satisfactory. Although the tightness of the money market has had a marked effect on many lines of business, the talking machine industry did not seem to suffer to any noticeable extent, the majority of our dealers reporting the best year since they were in business.

"Wherever I visited I was assured of the appreciation by our trade of the many co-operative measures that we have introduced the past year. The aggressive dealer invariably utilizes any sound and logical plans or ideas that the manufacturer offers him, and this was particularly true during 1913, when the Columbia dealers were extended real and up-to-date co-operation, which they accepted at its face value and used to produce increased profits."

E. N. BURNS TO EUROPE.

Edward N. Burns, vice-president of the Columbia Graphophone Co. and manager of its export department, sailed last week for an extended trip to Europe. While abroad, Mr. Burns will visit all the important European countries.

The days for talking are over—act.

FROM OUR EUROPEAN HEADQUARTERS

2 GRESHAM BUILDING, BASINGHALL STREET E. C., LONDON, W. LIONEL STURDY, MANAGER.

REVIEW OF TRADE CONDITIONS IN ENGLAND IN 1913.

A Most Interesting and Detailed Analysis of Developments in Various Departments of the Talking Machine Industry Presented by Our London Representative—Every Aspect of the Situation Covered in a Most Informing Way—The News of the Month.

(Special to The Talking Machine World.)

LONDON, E. C., January 6.—The year that has just made its exit may well be described as a memorable one in the history of the talking machine trade. But before I proceed to a review of the more important events, it will be interesting to quickly survey the situation immediately preceding the festive-time. In the early part of Xmas week I took the opportunity of making a few calls upon the leading houses with the object of personally ascertaining just how things stood in relation to business. Everywhere I found an extraordinary state of activity prevalent, and so preoccupied with work were most of the officials that I had to rely in the main upon my own observation. So great was the demand for records and machines that in the last few weeks of the old year most of the manufacturers and factors were forced to install night shifts. By this means only it became possible to satisfy all wants, within the limit of stocks, of which daily replenishment was necessary in all cases.

Inquiries confirmed the opinion that the cheaper class of record has enjoyed a wonderful vogue, and is selling freely in all districts. During the few months of their existence millions have been sold, the only difficulty being to press them fast enough. There has been, too, an increased call for cheap machines, but it is satisfactory to note the better makes are well in the running. I am informed though that in records half-crown sales are down owing to the many cheap discs, and the fact that several records equal to them in quality are obtainable for eightpence.

December altogether has been a boom month for trade, which in bulk is far ahead of last year, even time considered. It is said that profits do not compare so favorably, and one can well understand it, having regard to the wholesale price reductions and consequent keener competitive conditions. Notwithstanding all that, it is evident the last month of the old year will remain one of pleasant memory for all.

A Review of Trade Conditions in 1913.

In retrospect 1913 deserves more than a superficial survey, for it is brimful of important happenings, which are likely to exert an influence upon the course of trade in the new year. Almost every year the industry undergoes evolutionary changes, in themselves progressive and helpful, along lines which make for expansion of trade, prestige and influence, achieving in one long series of steady improvements a position as closely allied to musical art as it may expect to reach under the present method of harnessing and reproducing sound mechanically.

Those who have watched the trend of events during the last decade will, I imagine, accept the foregoing expression of opinion as reflecting the actual artistic and scientific aspect of the situation existing to-day. To this happy position, 1913 has contributed its quota of development, in what degree and to what extent it is the purpose of this article to expound.

The object, it seems to me, may best be attained by a brief chronicle of the most important events, an examination covering the whole field of commercial, scientific and artistic endeavor in talking machine trade circles.

Influence and Power of the Gramophone.

The growing influence and power of the gramophone was never more apparent than in the past year, of which we have abundant evidence quite outside the ordinary trade channels. For political purposes some of the most eminent men of the day,

including Cabinet ministers, have availed themselves of its service; even the suffragettes find it a good medium—not its best in comparison, I must admit—through which to propagate their views. In education the gramophone is becoming more and more indispensable, especially for the teaching of foreign languages, and students in many other directions find it an invaluable aid. Drilling and dancing is carried on, and even learned, with the assistance of this wonderful instrument, which, too, has often been utilized as an effective substitute in churches for choir or organ. You will find it in workhouses, schools, at recitals, a treasured companion of Arctic and other explorers; find it, in fact, everywhere. All of which clearly demonstrates the remarkable position the gramophone now occupies in all walks of life. To those interested in its development a very pleasing sign of the times is the broader attitude of the general press. The one-time prejudice and dislike of all mechanical music has given place to more favorable consideration, as witness the statement of a leading daily that "the gramophone as we know it to-day stands for something a good deal more than the triumph of necessity over prejudice." And this is but a reflection of the general opinion of the press to-day.

I have briefly referred to these aspects of the situation because it is a significant indication of the progressive development of the record and instrument trade during 1913.

The Year's Progress on the Scientific Side.

The root principle of sound recording and reproduction was comparatively unaffected by the several improvements brought to light during the past year, yet credit is due the different efforts made by inventors in the direction of perfecting existing methods and apparatus. Although the Poulsen patent is one of very old standing, I think a reference to it is justified in view of the interest aroused during the year by a court application for its extension. The Poulsen method of recording sound is quite unique, but great difficulty in its commercial application has been experienced, and I believe I am correct in saying it has never been put to practical use although doubtless the inven-

tion is a valuable one. The patent is described as consisting of an apparatus for the storage of speech by means of a magnet and magnetically influencing wire. By means of electrical currents set up in speaking on to this wire or band of metal actuating a magnet both locally and crosswise, it is stated that a record of the human voice could be obtained and afterwards reproduced with perfect fidelity. The importance of this magnetic phonograph idea, which was considerably improved upon during last year, will doubtless receive general recognition in the near future. It certainly predisposes one to look forward with hope to the abolition of all imperfections in reproduction of sound with a new system of recording.

The Edison disc, which was expected last year, is *fait accompli* in America. One day we may see it on this market. I have been privileged to inspect a sample record, but few have heard one. From all accounts emanating from the States it may be concluded that the Edison phonograph-cut disc marks a step forward in sound reproduction, and if this be so, it is assured of a good welcome in England.

Many intelligent men aver the real future of sound recording will be revealed with the perfection of the method of photographing sound. It may not be generally known that it is quite feasible, and experiments during the past year tend to confirm this. The inventor is T. H. Williams an electrical engineer, who has made a close study of the subject. He discards altogether the present principles of mechanical music, and claims to have succeeded in reproducing photographed sound where Faraday, Poulsen, Duddell and others have failed. The inventor, Mr. Ruhmer, was an exception, but his methods are said to have never reached a practical stage. Mr. Williams has devoted himself to this problem, and says complete success is not far distant. He claims that his "Photo-gramophone" entirely does away with needles and the ordinary solid record. Under his system speech and music are entirely reproduced through the media of light, electricity and compressed air. A practical demonstration of the invention is promised in the near future. There is good promise in Mr. Williams' system and the trade will await the results with keen interest.

Another important feature of the year is in relation to the improvements effected in sound recording. It must be admitted, however, that the present system does not lend itself to any very radical departure, yet, confined as they are to the one channel, manufacturers' experts have managed to secure some small improvements, which, in the aggregate, represents progress. If not of a very substantial nature it merits the utmost encouragement, for anything which goes to suborn the mechanical aspect in relation to gramophone music is very welcome.

Machine and Record Developments.

Under the above caption a brief resumé of the changing styles and constructional departures in gramophones, coupled with a reference to the development of disc records, is of necessity a matter of extreme interest generally. During the past year it was clearly manifest that determined attempts were being made to relieve the somewhat monotonous regularity which previously marked the issue of what may be termed the orthodox pattern. In the Hornless instrument field several radical departures were in evidence. Different methods of fitting the amplifying chamber do not warrant much reference. The chief consideration to remember is that sound rises, and although doubtless it is of little material disadvantage that with most so-called hornless machines the sound is carried downwards, any tendency in the reverse and proper direction is worthy of being recorded. In this connection several machines embodying the correct principles made their appearance and I

STROH VIOLS

VIOLIN, VIOLA, ETC.

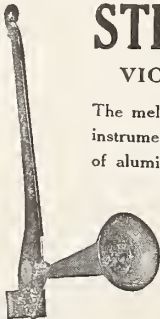

String Fiddle

The mellow and matured tone of these instruments, which are constructed largely of aluminum, yet possess *none* of the characteristics of the gramophone or wind instrument, is only one of its many points which are fully set out in an illustrated booklet which will be mailed free on request to the *sole makers*.

GEO. EVANS & CO.

94 Albany St. London, Eng.

OR

in U. S. A. to their sole representatives

OLIVER DITSON CO.

150 Tremont Street BOSTON
NEW YORK and PHILADELPHIA



Violin

FROM OUR LONDON HEADQUARTERS—(Continued from page 44).

learn that others are in course of preparation. One of the Marathon portable instruments is of entirely new design, it being absolutely hornless in the full sense of the word except that a sort of sound chamber of small dimensions is provided by means of a telescopic side which shuts in or out as required. The volume and quality of the reproduction is excellent, and the instrument itself must be regarded as a progressive step in machine construction.

A still more important departure perhaps from the ordinary method of construction came under notice in July. This was the introduction by the Columbia Co. of a unique motor plant built upon entirely new principles, being in fact, a combination of the whole of the motive power as a unit independent of and perfectly insulated from the cabinet. It consists of a metal motor board, (carrying the motor), breech-locking tone-arm and Regal reproducer all in one. Without expatiating upon the many claims attached to this equipment, it may honestly be said to represent a distinct improvement in its results over the usual mechanism, and certainly deserves to rank as one of the most important and eventful issues of 1913.

Still another introduction, the utility of which has yet to be determined, is represented by the combination of exterior-horn and interior-horn (portable) instruments. This feature is as yet in its infancy, and my own personal opinion is that it should so remain, for the consideration which actuates the purchase of one or the other type neutralizes the necessity for combining the two. In any case it is more or less an expensive luxury.

Coming to records we find that much the same conditions exist on the mechanical side as in 1912. The "Marathon" fine cut disc made enormous strides during the year, and both from the mechanical and artistic viewpoint, has created quite considerable notice in talking machine circles.

The Artistic Side of the Record Business.

Consideration of this aspect should rightly cover a multitude of points, but the exigencies of space confine one to a rather brief mention of the

more important features of record development.

A welcome move in the gradual elimination of suggestive records, which at one time formed a not inconsiderable amount of the total issues. Outside an isolated case or two, this objectionable feature is practically a thing of the past. In this respect then 1913 was a clean year; long may the voluntary censorship continue.

In the class of titles issued it is pleasing to note that greater attention is being paid by manufacturers generally to the listing of better-class music. For example, on most half-crown lists we find an increasing amount of operatic issues, and even so with lower-priced disc records. In itself this furnishes a remarkable index of the educational influence of the gramophone. Popular hits are still the commercial mainstay of the majority of manufacturers, but the demand for operatic, good ballads and other better-class records received an amazing stimulus during last year. And it is an ever-expanding trade to which I am pleased to observe record makers give every encouragement.

A direct result of the ragtime craze, which predominated during the year, and is still more or less in favor, was considerably increased business all round. It was undeniably responsible for the sale of thousands of extra records and many machines. Beyond that—of course a great consideration—few will regret the gradual decline of ragtime. The latter part of the year witnessed the birth from a popular viewpoint of tango, a not displeasing form of music on records. It can be regarded only as a vogue of the moment, so to speak, for in view of the intricacy and difficulty of the various movements, it is not likely to hold the field much longer.

A very important feature in relation to records is the exclusive artistic proposition which became more than ever the practice last year. Apparently it is a profitable plan to secure the exclusive service of a special public idol. In certain quarters, maybe, it represents a valuable selling asset, but generally I am inclined to believe it of not very material consequence. Many record makers have not

troubled to tie-up any artist, yet their trade is, and will be, unaffected. The most important asset is the prompt issue of the "hits" of the moment, and of a surety this consideration will ever determine the demand. Recognizing this salient fact not a few artists of my acquaintance have rejected offers for their exclusive service.

Points About the Copyright Act.

It is not denied that this bill removed a slight injustice under which composers suffered in the recording and publication of their works without monetary recognition from the gramophone industry, but it is safe to say that the amount of royalties paid during 1913 has far exceeded all preconceived estimates. As from July 1 last a large number of compositions automatically came under the benefits of the act, and the tax on record makers has, therefore, been phenomenal. Record sales have run into millions, and huge amounts are allocated each month for royalty stamps.

The act bristles with difficulty in the interpretation thereof, and some interesting law actions were heard during the last year, the result of which the trade as a whole is materially affected. One significant declaration to which the record companies have submitted is that an author is entitled to stipulate or control the form in which the score or libretto, as the case may be, shall be recorded. Even though his work or parts thereof have been recorded he can restrain the recording of any other version or mutilation which may not be in agreement. In other directions the tenets of the copyright act provisions have been sustained in law, and have made possible the avoidance of much difficulty, broadly speaking, in the smooth working of an act otherwise suggestive of future pitfalls for the record manufacturer.

One other source of considerable trouble and expense to manufacturers in connection with this act is the tracing of the rightful ownership of certain compositions and whether they are entitled to copyright benefit. Many works are invested in obscurity as regards copyright ownership, and

(Continued on page 46.)



To T.M. the King and Queen of Spain



To H.M. the King of Sweden



To H.H. the Khedive of Egypt



To H.M. the King of Italy



To H.M. the Shah of Persia



By Appointment To H.M. Queen Alexandra

"His Master's Voice"

—the trade-mark that is recognised throughout the world as the

Hall-mark of Quality

- AUSTRIA: Oesterr. Grammophon-Gesellschaft, m. b. H., 8, Krugerstrasse, Vienna.
- BELGIUM: Cie. Française du Gramophone, 51, Avenue de la Porte de Hal, Brussels.
- DENMARK: Skandinavisk Grammophon-Aktieselskab, Frihavnen, Copenhagen.
- FRANCE: Cie. Française du Gramophone, 115 Boulevard Richard Lenoir, Place de la République, Paris.
- GERMANY: Deutsche Grammophon-Aktiengesellschaft, 35, Ritterstrasse, Berlin, 542.
- HOLLAND: American Import Co., 22a, Amsterd. Veerkade, The Hague.
- HUNGARY: The Gramophone Co., Ltd., IV, Kossuth Lajos-Utca 8, Budapest.
- SPAIN: Cia. Francesa del Gramophone, 56, Balmes, Barcelona.
- SWEDEN: Skandinaviska Grammophon-Akti-holaget, 52, Appelbergsgatan, Stockholm.

- RUSSIA: The Gramophone Co., Ltd., 45, Nevsky Prospect St. Petersburg; 9, Golovinsky Prospect, Tiflis; 30, Nowia Svit, Warsaw.
- EGYPT: The Gramophone Co., Ltd., 13, Rue Stamboul, Alexandria; Rue Mousky, Cairo.
- EAST AFRICA: Bayley & Co., 8 Beira, Lourenzo Marques.
- SOUTH AFRICA: Darter & Sons, Adderley St., Cape Town; Mackay Bros., Rissik Street, Johannesburg; Mackay Bros & McMahon, 443, West Street, Durban.
- INDIA: The Gramophone Co., Ltd., 139 Balliaghatta Road, Calcutta; 7, Bell Lane, Fort, Bombay.
- AUSTRALIA: The Gramophone Co., Ltd., Hoffnungs Chambers, Pitt Street, Sydney.
- GREAT BRITAIN: The Gramophone Co., Ltd., 21, City Road, London, E.C.



Great Britain:

The Gramophone Company Ltd
21 City Road London EC

FROM OUR LONDON HEADQUARTERS—(Continued from page 45).

to a great extent the onus of discovery is placed on the firm desirous of recording the composition. This, of course, tends to considerable inconvenience, trouble and expense, and when the time comes manufacturers will have gathered a large experience upon which to base their claims for remedying the certain and many hardships inflicted by the copyright act.

It is worthy of mention that during the year, Newfoundland, Australia and other British Possessions passed legislation adopting the act.

The Year's Legal Troubles.

Aside from the important actions concerning copyright laws referred to elsewhere, the trade was unusually free from actions-at-law. Of course, quite a number of disputes arose during the year, but for the most part these were amicably settled outside the courts. There are one or two pending, I believe, although it is quite possible they will reach settlement without much legal aid. There were two trade-mark actions in 1913, and one or two other "name" disputes of comparatively unimportant interest. Of the former, the "H. M. V." trade mark was the subject of infringement by a suburban trader, the court ordering the destruction of the infringing apparatus, and an enquiry as to damages. The second case concerned the word "Invicta." W. A. Barrand & Co., Ltd., (in liquidation) made public claim to the word and threatened legal proceedings in any case of infringement brought to their notice. Objection was lodged by the Berliner Co. (Messrs. John Abraham & Sons, London agent), and it was proved to the satisfaction of the court that the name had never been registered. Application to register the word had been made by a third party who had allocated his interest in it to Messrs. Barrand, on whose behalf it was claimed they were under the impression the word had been duly registered. The Judge held that it had not and therefore the publicity was misleading. A nominal fine of forty shillings was imposed.

In the early part of the year the word "Lyric" was the subject of contention. The Columbia Co. had registered it some years ago, and they succeeded in restraining the now defunct Lyric Record Co. from using it.

Kalliope v. Blum, and Blum v. Kalliope, promised exceptional interest, but after a preliminary bout in the courts a compromise was reached to the satisfaction of all parties and beyond recording the fact, there is no occasion to enter upon a detailed account of the issue. Outside a few other minor legal disputes, the foregoing represents about the sum total of last year's appeals to the law of the land.

Advent of Cheap Records.

Under this heading I place the action of the trade in introducing the shilling record, for of all the year's happenings this must be ascribed the most important. Four months experience of the cheap record policy makes manifest that it cannot continue. Every new industry, by the law of competition, must sooner or later find a level. As things go ours is but a young industry, a matter of two decades, yet already it has been directed almost into the gutter. One's interpretation of a commercial "level" is the descent from the inflated-profit stage to a condition commensurate with reasonable trading returns for every section of the industry. Beyond that stage lies destruction, unless it were justified by economy in manufacturing costs and a cheaper channel distribution. In connection with the record trade an examination of the question reveals a most unsatisfactory state. Unprofitable alike for manufacturer, factor, or dealer, the persistence of the cheap record policy is calculated to undermine the stability of the whole industry, unless an immediate abandonment is possible. With such grave issues at stake, the rumor that the thirteen-penny and shilling records will be withdrawn, must—if it materialize—earn the gratitude of all who have the best interests of the trade at heart.

It may be argued by some that 1913 did not witness the birth of cheap records. That is partly true, but one must allow that those few in existence prior to last January were comparatively in-

significant and, moreover, it cannot be said they interfered to any appreciable extent with the sale of half-crown discs. On the other hand the marketing of the thirteen-penny record, immediately followed as it was by a host of shilling ones, disastrously affected the half-crown record sales. A large percentage of the public care nothing for artists and will not pay eighteenpence more for a particular title because it will be sung or played, as the case may be, by a performer of greater renown than the one responsible for the cheaper disc. It has been proved over and over again that given the record is good, the price determines the sale. Even so late in the day the immediate withdrawal of thirteenpenny and shilling discs would quickly operate in favor of the better priced records. There is much lost ground to recover, and the matter, to be successful, brooks no delay.

Cylinder Trade Depression.

Without descending into the realms of pessimism, an impartial view of the phonograph trade situation reveals a most unsatisfactory state of things. It is, of course, not entirely surprising in the face of recent events. For several years the phonograph business has been a declining one. But the curious part is that the very people who made and built up the one-time splendid trade in this country should themselves be largely responsible for its almost total extinction. The closing down of the Edison factory and now the Clerkenwell road premises and consequent disbandment of the staff, amounts nearly to a retreat from this market. The only remaining vestige of the business will be the recording department. Orders have now to be sent all the way to America, from where business arrangements are ratified. The difficulties of conducting trade over such a distance were soon unhappily apparent, for the policy which dictated centralization of the European business at Orange has done more to ease the phonograph trade over the precipice of destruction than the hundred-and-one new devices which were introduced too frequently on this unstable market. In short, the cylinder trade is practically dead. The largest British house, Edison Bell, has announced its intention of destroying all matrices; in itself the most significant confirmation of an all too obvious situation. It is an all-disc trade here and factors tell me the cylinder business is one long series of discouragement. With that I will pass on to a brief reference to one of two other items of interest.

The Dealers' Protection Association.

Little is there to say in reference to this matter, and it may therefore well include a mention of price-maintenance conditions during the year. In this regard 1913 stands for the most flagrant breach of the foundation of sound commerce; the worst year of all in the trade's history. Price-cutters have been having a ripping time, and they naturally protest that if manufacturers and factors indulge in the practice, what has the poor dealer to do? Anyway he does it—he "cuts" to the last halfpenny. An unusual number of failures among retailers during the year is the natural result. One had expected some activity on the part of the Dealers' Association, but if the truth be known, it is without sufficient membership strength to accomplish much. And not until a more wholeheartedly energetic policy obtains can it expect to wield a strong voice and make itself felt as a power in the land. Meanwhile, its influence is more or less nil, especially so in regard to its avowed object, the suppression of price-cutting. This, is I have said, is more or less a general practice. The unfortunate fact to remember is that outside "H. M. V.," Columbia, Marathon, Winner and Edison Bell, no patents cover the sale of disc records, and no infringement, therefore, obtains by selling below established prices. One or two other records are pretty effectually protected by price-agreements, but on the majority dealers fix their own price and for the most part protests are ignored. From the price-maintenance aspect the year has, therefore, been a most unprogressive one.

Miscellaneous.

The reduction of your general tariff will be to the advantage of almost any other industry but

ours. British record makers might build up a pretty good trade with the States were it not for your patent monopolies, which neutralize any good the tariff reductions might have conferred upon foreign manufacturers.

During 1913 the idea of issuing signed or autographed records became more in favor. It will doubtless be a stronger feature of the new year trade.

The Talking Machine Society movement is growing apace and received further stimulus last year. This feature is generally recognized as of some importance, and is encouraged by all manufacturers. The movement is spreading among users in the principal towns, and there now exists over a dozen different societies throughout the country.

Nineteen-thirteen credit conditions were exceedingly loose. Dealers take as much as three, six, or twelve months credit, or longer, if they can pass bills for these periods. The acceptance of bills is a growing practice, notwithstanding its unsound policy.

Business failures during the past year were unusually heavy among the retail fraternity and fairly normal in other directions.

Nineteen-thirteen witnessed the incorporation of about 15 new companies, most of which are now carrying on operations.

Several firms were forced to take larger or additional premises and among the more important removals may be mentioned Columbia, Lockwood, O. Ruhl, Ltd., Craies & Stavridi, and Hands' record factory.

Raw materials went up in price during the year and in almost every department an increased first cost is registered. An important financial issue was made public the early part of 1913. This was the Gramophone Company's £300,000 worth of debenture stock. At the time money was none too free, and it was accepted as a tribute to the financial standing and reputation of the "H. M. V." company that the whole amount and more was immediately forthcoming.

A noticeable tendency of the year was the prolongation of the so-called season, well into the spring months. That is a point well worth recording. One day, perhaps, we shall not talk of "seasons."

Nineteen-thirteen in one sense should be described as a year of amalgamations. Most of the big Continental firms now operate under one flag, and groups have been formed in other directions. All of which have been duly reported in these columns from time to time during the year.

The house-to-house canvassing trade is making great strides, one firm alone having a weekly turnover of £1,500. The policy of trading is the presentation of a machine upon a contract to purchase 60 half-crown records in 12 months; one a week at least. Contrary to the one-time opinion, this business opening up as it does a new field, confers a general benefit on the trade. Records additional to the contract are purchased from local dealers, and many users are encouraged to possess better machines than those supplied.

To sum up, 1913 might have been described as a good year had it not been for the introduction of unprofitable business in the shape of shilling records. Despite a greatly increased turnover, the financial aspect is not good, net profits being down as compared with the preceding season. Keener competition, higher cost of materials and reduced profits, mean that it costs considerably more, proportionately, to do the same amount of business. Which is altogether unsatisfactory. Fortunately the new year promises better prospect, for whatever may be said, the shilling and thirteen-penny records must go! To all my readers—"A prosperous and healthful New Year."

Records for January.

The new year opens up splendidly for "H. M. V." agents in the sense that a particularly attractive list of likely good selling titles is provided for the initial month. Each month since last September the Gramophone Co. has made a feature of issuing a combined record by two celebrated artists, that for this month being described as "perhaps the finest of the series." It is "Elegiac-

FROM OUR LONDON HEADQUARTERS—(Continued from page 46).

Mélodie," one of Massenet's masterpieces, sung by the great Caruso, in concert with the violin, in the hands of no less than Mischa Elman himself. That it is a wonderful record goes without saying.

In another class, a second "special" is "Another Good Thing You've Missed!" from the Drury Lane pantomime, "The Sleeping Beauty." The two original artists—George Graves and Will Evans—are responsible for the record, which is throughout full of laughter-raising fun.

The "H. M. V." Co. has achieved a triumph in the fine records they have secured of the much-talked-of Berlin Philharmonic Orchestra, under the baton of the equally famous Arthur Nikisch. The initial issues comprise Andante in two parts (two records) from the "Fifth Symphony" (Beethoven), which is beautifully interpreted by the great conductor's organization.

The complete issues for January are as hereunder:

Twelve-inch double sided.—Suite, "Bohemian," "The Appeal" and "The Caravan" and "The Tarentella" (Ord. Hume) Band of H. M. Coldstream Guards; Suite, "A Dream of Egypt," (2) "Within the Sphinx Solemn Shade"—"Pomegranate In Your Mouth," and (4) "I Wakened When the Moon" (Woodforde Finden, arr. by Percy E. Fletcher) Band of H. M. Coldstream Guards; "Destiny—Valse Lente" (Baynes), and "Dance of the Disappointed Fairies" (Air di Ballet) (La Touche) Mayfair Orchestra; "Je sais que vous êtes jolie" Two-Step (Christini), and "Maxixe Bresilienne" (Salabert) Mayfair Orchestra.

Ten-inch, double-sided.—"The Linnet" (Piccolo Polka) (Piccolo solo by Sergt. W. Valentine) (Brockett), and dance intermezzo "Sunbcams" (Gerald Lane) band of H. M. Coldstream Guards; "Little Grey Home In the West" (Cornet solo by Corpl. G. Moran) (Löhr), and "Süsse Küsse" (Vollstedt) band of H. M. Coldstream Guards; "Swedish Wedding March" (Söderman), and "Prayer From Moses" (Rossini) (arr. by F. Godfrey) band of H. M. Coldstream Guards; "June" (Baldwin Sloane), and "Some Boy" (Dave Stamper) Mayfair Orchestra.

Twelve-inch, single-sided.—"Ireland" (Stanford) Edmund Burke; "The Kerry Dance" (Molloy) Charles Tree; "The Island of Roses and Love" (Morét) Miss Lucy Marsh; "Mother's Maxims" (Pellissier) Miss Margaret Cooper; "In a Garden of Roses" (Sanderson) Miss Perceval Allen and Robert Radford; "Rhapsodié" (in English) (De Koven) and "Serenata Inutile" (Op. 84) No. 4 (in Italian) (Brahms) Mme. Tetrzini; "Che Gelida Manina" "La Bohème" (Puccini) Guido Ciccolini; "Minuetto-Vecchio," (Op. 18) No. 2 (Sgambati) Mark Hambourg (piano solo); "Air" (Bach, arr. by Squire) W. H. Squire ('cello solo); "Hunting Calls," The Rt. Hon. Viscount Galway, M. F. H.; "My Boy" (Kennedy Russell) Miss Florence Smithson; "Susie 'Oo" (Elton) G. H. Elliott and chorus; gems from "The Belle of New York" (Kirker) Light Opera Company.

Ten-inch, single-sided.—"The Foggy Dew" (Clay) John McCormack; "From the Land of the Sky-Blue Water" (Cadman) Miss Alma Gluck; "Down in the Forest" (Landon Ronald) Hubert Eisdell; "Cumley Down—Sons of the Devon Moor" (Oliver) Stewart Gardner; "Faust" trio from Prison Scene, Act. V. (Gounod) Grand Opera Trio; "Souvenir" (Morceau) (Drda) Miss Maud Powell (violin); "Just a Plain Girl" (Tennent) Tom Clare.

To Increase Society of Authors.

According to a contemporary a movement is on foot to increase the Society of Authors and to extend its benefits to British composers. Under the Copyright Act, 1911, the composers opportunities and responsibilities have been enlarged. For the past two years the composers' sub-committee has been sitting at the Society of Authors. This committee deals with all matters affecting the status of the composer. The society collects his fees at the lowest possible rate. It advises him in his dealings with publishers, exposes unfair and

sanctions fair contracts, supports him financially by maintaining actions-at-law in his interests and offers him an intelligence bureau and a trade protection society under expert management.

Gramophone as Professor of Tango.

A distinguished company gathered on Wednesday, December 10, in the White Room of the Savoy Hotel to see—and hear—demonstrations of the tango by famous dancers. Four pairs of dancers, including Destrées & Layunta and Roland and Marion Mitford, of the Palace Theater, showed both the Brazilian tango with its thrilling *elan* and the highly graceful English version: the feature of the afternoon was the perfection of the "orchestra" impersonated by "His Master's Voice" cabinet grand gramophone and tango records.

Dancers complain bitterly of the inaccuracy of many orchestras where tango is attempted; first-class organizations often fail to get the tempo correct. These records are endorsed by the dancers themselves, who declare them perfect to dance to.

Some very tasteful brochures have been issued by the "His Master's Voice" people to announce these new records. Learners of the tango everywhere are using this instrument to attain proficiency.

Thomas Edens Osborne a Live Wire.

In concert programs, newspapers and many other publicity sources, the advertisements of that well-known Belfast talking machine factor, Thomas Edens Osborne, appear with unflinching regularity representing an example of enterprise which other dealers might well copy. At entertainments, charity and otherwise, Mr. Osborne with his Auxetophone is usually a welcome contributor to the evening's enjoyment, and almost every day there is a newspaper reference to his kindness. Such tributes have made quite a public man of him, and I do not doubt but that so prominent a personality is justly regarded as one of Belfast's institutions. The distinction is well merited, for Mr. Osborne never seems happy unless he is contributing to the entertainment of the community at some function or other.

New German Trade Mark Bill Held Up.

It may be of interest to traders generally to learn that the proposed new German trade-mark bill cannot be introduced into the Reichstag for some considerable time. As a matter of fact it is in an incomplete state, its exact provisions not having as yet been determined.

New Companies Incorporated.

Warroner's, Ltd., musical instrument manufacturers. Capital, £1,000. Office, 15 New Oxford street, London, W. C.

Roll Music Co., Ltd. Capital, £1,000. Office, 93 Worship street, London, E. C.

Independent Music Club, Ltd. Capital, £10,000. Office, 13 Pembroke Gardens, Kensington, London.

Columbia Issue "Aida" Complete.

The announcement of a complete edition of records of the famous opera "Aida" is conveyed to us in a handsome leaflet just issued by the Columbia Co. We learn that the opera is complete in 34 selections, making 17 double-sided 10-inch records. These records, says the announcement, have been specially sung by some of Italy's greatest artists, among whom we notice, Signors Armanini, Martino and Bettoni, and Signoras Anita, Chelotti, De Perez, Remondini, and others, the whole of the series, to ensure absolute correctness, being recorded in the Milan laboratory.

It is typical of Columbia policy that the issue is thoroughly carried out, this being specially noticeable in the presentation, with each set of records, of a copy of the published libretto giving the words in both Italian and English. The pages of the libretto are specially marked to show where the records occur.

But the thoroughness of the Columbia issue does not end here. For in addition to an art folder giving the cast as represented by the records, the whole series of records are enclosed in a fine art album, gold-lettered, and bearing on the front an inset panel photograph of the composer, Verdi. The libretto and art folder are accommodated in a special pocket at the end of the album.

It is quite evident that the Columbia Co. intends to capture the popular taste with this "Aida" album, for they have priced it at £3 complete.

Paul H. Cromelin's Achievements.

In view of the recent transference of all Edison business to the American headquarters, the London staff has been disbanded, and Paul H. Cromelin's resignation has been accepted. As managing director of the London office Mr. Cromelin concentrated every effort to stem the tide of adversity surrounding the cylinder trade in this country, but no power on earth could effect this in the face of circumstances, and of the trade exigencies. In every other department of the Edison business substantial progress has been registered under Mr. Cromelin's able guidance, essentially one of keen foresight and extreme commercial acumen.

In the comparatively brief period of his stay among us, Mr. Cromelin took a prominent part in all matters affecting the welfare of the industry, and in particular the valuable work he rendered in connection with the difficulties of the copyright bill, will alone ensure for him a warm place in the memory of the British trade. His arrival in this country happened at a most opportune moment, for at that time difficult negotiations were on foot; we were in the thick of the copyright skirmish, and the outlook altogether was not over bright. Mr. Cromelin's wide experience of legal matters combining the art of translating vaguely worded acts into understandable language, which he freely placed at the trade's disposal, proved of immense assistance in defining the exact position of the mechanical instrument industry. The subsequent joint representation made in official quarters, resulted in securing for the trade some beneficial modifications of the act. Mr. Cromelin's whole-hearted efforts in this direction have won for him general recognition from the leading men of the industry, and he has been the subject of many eulogistic references in the trade press. Largely the outcome of his initiative a company was formed under the title of Universal Copyrights, Ltd., for the protection of trade interests. It mainly disposes of all matters relating to royalty stamps, copyright-ownership investigation, and places much valuable advice in the hands of its members, which comprise practically all manufacturers or records. In addition the company holds contracts with upwards of 100 publishers and composers, and its sphere of influence is expanding rapidly.

In the course of conversation with your correspondent Mr. Cromelin referred to his return to Washington at an early date where he intends to retrace at the Bar, from which he has been sidetracked for so many years looking after the Columbia and Edison interests. Our best wishes go with him for a prosperous new year.

Another recent departure from the Edison Co. is their sales-manager, W. Denville Simons, who, I learn, we shall shortly welcome back to the fold with an entirely new proposition. A man of such genial personality and wide experience of the trade is predestined to enjoy a full measure of success, for which we tender our heartiest wishes.

Christmas-Week Advertisement.

Special praise is due the efforts of those manufacturers in the direction of taking newspaper space wherein to emphasize the claims of the most suitable gift for young and old—the gramophone. During Xmas week many attractive advertisements appeared, all telling the same story, making trade for the dealer, and incidentally bringing happiness and increased joy to many a family gathering, as the result of "somebody's" judicious outlay. Several effective announcements by the Columbia Co., Pathe Freres, Marathon, Edison, Bell, and others in lesser degree, carried the message, but special mention should be made of the "H. M. V." advertisements. These have been appearing in the best journals throughout the season, the last splash—half-pages in the Mail, Telegraph, Mirror, News and Leader—a few days before the 25th, creating unusual interest. They told how the Xmas gift problem had been solved and illustrated a series of instruments at various prices to indicate that there was "a present for all."



**Marvelous Maggie Teyte—another
Columbia exclusive—a popular favorite
—a singer of records that sell—a magnet
for your store.**



*(Write for "Music Money," a book "full of meat" for those
dealers interested in quick and frequent turnover of capital.)*

**Columbia Graphophone Company
Woolworth Building, New York**

NEW YEAR OPENS WITH GREAT POSSIBILITIES

**In the Cleveland Trade, Judging from Demand the Early Weeks of 1914—High-Priced
Instruments and Records Formed Large Share of Holiday Business—Local Jobbers
Took Good Care of Their Dealers—Few Complaints Heard Throughout the Trade.**

(Special to The Talking Machine World.)

CLEVELAND, O., January 8.—The close of 1913, throughout the holiday season, found the talking machine dealers busier than they had ever been in any previous season. One thing that especially pleased was that practically without exception they had an ample stock of instruments and records to meet the unusually large demand. A noticeable feature of the sales was that while a very large number of the high-grade instruments and records were sold, about an equal number of the lower priced ones were disposed of, demonstrating that all classes are seeking this means of enjoyment.

The new year opened with large possibilities, as trade has continued in pleasing volume to date. Locally, as in other sections, during the fall months there was some depression in trade generally, which was reflected in the talking machine business, but the signs of the times are now hopeful, with the reopening of steel and iron mills of this section giving employment to thousands who were recently idle.

The Phonograph Co., distributors of the disc and cylinder Edison phonographs, garnered encomiums and ducats during the holidays. L. N. Bloom, secretary, said: "Our business was, and continues, very fine. We were kept busy day and night all last month in both the wholesale and retail departments. Everybody expresses the highest admiration of the Edison instruments. We are fully satisfied with results and prospects since opening our new store.

The Caldwell Piano Co. did a large holiday business and reports trade is excellent.

The popularity of the Union phonograph specialties is manifest in the general favor with which they have been received by dealers everywhere. The Union Specialty & Plating Co., the manufacturer, was rushed and throughout December was compelled to work a full force day and night and Sundays on orders from all sections of the country of which it is in constant receipt. The management states the business is phenomenal and that the company has orders in hand to keep it busy for several weeks. H. B. McNulty, general sales manager, is away on a trip East.

Manager Madson, of the local Columbia store, is around with an unusual satisfied smile. He states that business continued exceptionally fine through December clear up to New Year's, and that it still continues, bulking large in machines and records of all kinds. The year, he stated, was one of genuine prosperity, while the past month's sales were nearly double those of a year ago.

Business with the Eclipse Musical Co. has been booming ever since Thanksgiving. Especially has this been true in the wholesale department, under the management of P. J. Towell, who is one of the busiest men in the city.

Miss Young reports the biggest holiday and mid-winter talking machine business the McMillin's ever had. Profiting by the experience of former years, the company trebled its usual order for machines last June, so it was able to take care of all customers nicely and to accommodate a few fellow dealers who ran short.

The Victrola department of the B. Dreher's Sons Co. has been a busy place for a month past. The manager said sales were of the best grades of both instruments and records, and that the Victrolas were practically sold out.

The William Taylor, Son & Co. is making much of its talking machine department. The manager, T. A. Davis, Jr., says he was swamped with holiday business, which was surprisingly good. Sales, he said, were principally of the higher-grade instruments and up-to-date records, and that double the business of a year ago was booked.

The Taylor Arcade branch of the Phonograph Co. is doing fine. W. C. Troth, in charge, says he had a splendid holiday trade and prospects are daily increasing.

Among some of the distinguishing features of the holiday trade Mr. Friedlander, of the Bailey Co., mentioned the fact that trade in December was not only a large per cent. of gain over last year, but that there were many more spot cash sales and that collections were much easier. Edison sales are measuring up large, and together with the Victor and Columbia and the small musical instrument trade the company is doing an extensive business.

Phil Dorn, of the Collisler & Sayre Co., is always happy when fingering a pair of skates, baseball or other sporting paraphernalia, but when he is in the talking machine department he becomes at once a Victor enthusiast, and his persuasive manner reaches the heart of the Victor purchaser, who departs in the happy possession of a Victrola. Many a machine has been sold through his gentlemanly endeavor. Phil says he got a goodly share of the holiday trade.

A large increase in business, covering the holidays, over that of a year ago was scheduled by the W. H. Buescher & Sons Co.

Miss Vokes, manager of the talking machine department of the May Co., stated trade in both instruments and records was splendid. "We closed out nearly our entire stock of the best grades of both Victor and Edison instruments," she said.

The Euclid Music Co., Victor Victrola and Edison phonograph dealers, located on upper Euclid avenue, has been doing a splendid business since opening last November. The management reports good sales of instruments and records and is highly pleased with the prospects.

Charles I. Davis reports the most satisfactory conditions. He states he did the biggest holiday

business of any previous season, and that his present trade is of the best.

Norman H. Cook, manager of the talking machine department of the W. F. Frederick Piano Co., took a run down to Warren Pa., and ate Christmas turkey with his mother. He says the company had the Victor goods this year and that the sales were large, the volume of last month's business being twice what he expected.

The graphophone department of the Marks Co. has been doing a very satisfactory business ever since the opening of the new store. Mr. Robinson, manager, stated that business was very good and that the holiday trade was fine. It being a "woman's store," it is becoming a fashionable resort for both ladies and gentlemen, and the musical feature is attractive.

SPECIAL DANCE RECORD BOOK

Issued by the Columbia Graphophone Co. and
Compiled Under the Direction of G. Hepburn
Wilson, M.B.—Will Be Found Convenient.

In recognition of the country-wide demand for dance music the Columbia Graphophone Co. has just issued an attractive four-page booklet devoted exclusively to this class of records. It is designed in several colors, the illustrations being appropriate to the type of dance music which they represent. The front and back covers show the four latest dances as they are actually danced, and the color scheme is effective.

The lists of Columbia dance records featured in the new booklet are compiled under the direction of G. Hepburn Wilson, M.B., one of the authorities on modern dancing, and his detailed knowledge of the music appropriate for the new dances was most invaluable in listing the various Columbia numbers. One-steps, Boston hesitation waltzes, turkey-trots and tangoes are all presented in this new booklet, which should prove a timely addition to the Columbia dealer in promoting the sale of dance records among his clientele.

CATALOG OF REPAIR PARTS.

Under date of December 19, the Victor Talking Machine Co. sent out to its dealers a new catalog of repair parts for the Victor automatic brake, repair tools and improved Victor fiber needle cutter. This catalog, which is up-to-date in every detail, takes the place of the repair part catalog issued September 1, which has been used to good advantage by the trade. The latest catalog features the usual illustrations showing the various parts mentioned in the pamphlet.

TAKES ON COLUMBIA LINE.

Among the recent additions to the list of Columbia representatives in near-by territory, are Samuel Weinstein, 54 Morrell street, Brooklyn, N. Y., and Seaver Bros., Fifty-second street and Third avenue, Brooklyn, N. Y. The latter concern has placed an unusually substantial order for Columbia machines and records, and has already laid the foundation for an excellent Columbia business.

THE VALUE OF THE "FOLLOW UP" CAMPAIGN TO DEALERS.

At No Time in History of Talking Machine Trade Was It So Necessary for Dealers to Be Up and Doing in Order That There Should Be No Backward Movement in Their Business—Territory Must Be Worked Energetically to Insure the Best Results.

One often hears it said that the talking machine business is a profitable one, and so it is, but not to the retailer who puts a sample instrument in his window and then expects to be immediately swamped with orders. What is required is well-directed and persistent effort, which can be counted on to bring results. The retailer must work his territory and see to it that the people in his district individually know that he sells certain instruments and records and what their merits are. A lady said recently, "I would not give one of those things house room." The "thing" referred to was a splendid talking machine, and one with which she would be satisfied, but her conception of it was based upon a cheap instrument she had heard several years ago, before the numerous improvements of the last few years had been made. In this particular instance the local retailer was mostly to blame. The woman had often been in his store. He knew she was fond of certain compositions, and yet he never once told her that a particular record had come in the last shipment and had it played for her. An ordinarily aggressive dealer would have sold that woman a talking machine months before she had made the remark mentioned above. In commenting upon this subject a successful retailer said, "When you get out and endeavor to dig up business it often happens that you can make a sale where you least expect to."

The show window has its place—an important place. Other factors all help in selling talking machines, but nothing can take the place of "follow up." Impressing this phase of the business some time ago, Geo. P. Metzger, the well-known advertising expert, handed out some excellent points. Among other things he said: "The follow-up is one of the biggest business getters in the talking machine trade, as well as others, and rivals in importance advertising and the quality of the goods itself. In laying out a follow-up campaign the entire public may be divided into classes as follows: First, the man who is interested and comes into the store for the purpose of making further investigations; second, the man who wanders into the store, but is not interested; third, the man who telephones or writes for information; fourth, the man who, while interested, has not called, telephoned or written; fifth, the man who is not interested in any way, and hasn't made any effort to find out the possibilities of the instrument, and so on down the line. No prospect who has shown the slightest interest in talking machines

either by calling at the store or writing should be allowed to get away without at least giving his name and address, and should receive the constant attention of the dealer until the sale is completed. The talking machine dealer should have a leaf from the book of the shoe salesman who never starts to make a sale until he has removed the shoe of the customer, for by that means the customer is prevented from leaving suddenly if dissatisfied, except in his stocking feet, and the salesman can present many arguments and show additional styles while the shoe is being replaced. Such a system could be readily instituted in the talking machine store.

TRAVELING MEN WHO ADVANCE.

One of the Requisites Is an Examination of Conscience to Show Whether Progress Is Being Made—Timely Topic Opening of Year.

How does the average traveling salesman of today account for the great success some of his fellow members of the craft have made, while he has not moved forward so rapidly? Some say it is luck, and others say greater advantages, while still others attribute it to opportunity, but the true reason why you have not advanced lies with yourself.

We live in an age where all men have equal chance at least to show their worth, and if you fail, it is because you have not trained yourself to think out the problems which stand in your way.

Pause and ask yourself: "How much real thinking have I done in the last year? Have I allowed some one else to think for me, while I have remained a cog in the wheel instead of contributing to the motive power that turns it? Have I grown with my position, or have I allowed my position to grow away from me?" Not until you can answer "yes" to each and every one of these questions can you hope to advance.

You often meet on the road men who have grown gray in the service and who know every telegraph pole from Maine to California, yet who are just where they were twenty years ago, while other salesmen stay on the road a year or so, are advanced to manager and so along the line to the general offices, and perhaps in the firm. The answer is, the man who advanced trained himself to think of nothing but advancement and permitted no other thoughts to enter his mind. By sheer force of will backed by ability he reached the goal of his desires.

"The great majority of those who are not inter-

ested in talking machines remain in that condition simply because they have never been approached. I know of a whole street in a Connecticut city where everyone owns his own home, and where a talking machine salesman has never made his appearance for the purpose of introducing the talking machine directly into the home. I would wager that I could go into the territory of practically any dealer and call upon ten families at random and find that only two owned machines, and of the balance six had never been approached by a salesman for that dealer. It is to remedy such a condition that the dealer should adopt a careful and systematic follow-up. A good rule is for the dealer himself to make it a point to call upon at least one new family per day, and introduce his line with the accompanying offer to give a demonstration, either in the home or in the store, as convenient."

CO-OPERATIVE INVESTING PLAN.

New Scheme of Encouraging Thrift Among Employes Put Into Operation by an Ohio Department Store—Has Many Points of Merit That May Interest "Talker" Trade.

A new plan for encouraging thrift among its employes has been put into operation in a prominent Ohio department store which may interest talking machine men. It is a co-operative investment scheme, the object of which is to promote saving and to assist employes desirous of making investments on small capital. The movement is being carried on under the head of a savings bureau, and it began work with a pledged deposit of \$4,100. This amount consisted entirely of pledges made by the buyers of the store. This money, together with other deposits received from the employes, will be deposited with a trust company at 4 per cent. interest until it has grown large enough to be invested. In addition to the interest paid, it is planned to pay dividends semi-annually on deposits of three months or more from the future earnings of the fund. A regular weekly or monthly deduction from the salaries of the employes making use of the bureau may be arranged by them if desired. The store paymaster will apply the deducted amounts direct to the employes' account in the bureau.

The Mead Stationery Co., which is one of the dealers on the books of the New York Talking Machine Co., ascribes its success to several reasons, chief among which are the quality of Victor products, the national advertising of the Victor Co., and the newspaper advertising of the company itself. The Mead Stationery Co. is to be congratulated on its latest advertising campaign, which is deserving of excellent results.

IN the clinches you can rely upon the **Ditson Victor Service.** Profits are contingent upon *our fast work*—and we know it.

STOP saying to your customers: "We haven't got it," because you can get it from **DITSON.**

FAST Victor service is our aim, and that we hit the mark is proved in our rapidly growing clientele of dealers.

ALL Victor Styles, records and parts, with a complete line of albums, cabinets and needles.

WE specialize upon Victor goods exclusively, and correspondence with dealers desiring the best in Victor service is invited.

Oliver Ditson Company,

Boston, Mass.



Whether looked at from the viewpoint of art, reproduction, volume or tone, the Columbia Grafonola "Colonial," \$150, table design, is a winner for any line.



(Write for "Music Money," a book "full of meat" for those dealers interested in quick and frequent turnover of capital.)

Columbia Graphophone Company
Woolworth Building, New York

QUICK RESULTS WITH EDISON DISC.

Hardman, Peck & Co. Report Excellent Volume of Sales in New Line During the First Fortnight It Was Handled by This House.

"We have closed a remarkably good business with the Edison disc line in the few weeks that it has been established in our institution," stated Ashley B. Cohn, of the wholesale traveling staff of Hardman, Peck & Co., 433 Fifth avenue, New York, the prominent piano house. "We had expected that the Edison line would be accorded a favorable reception by our clientele, but the instantaneous response to our advertising and that of Thomas A. Edison, Inc., has pleased us greatly.

"Although our Edison disc department has been established but a short time, and our department has only been completed recently, we have already closed a number of sales of the more expensive models to music lovers, who were greatly impressed with the tonal beauty of the new Edison disc phonograph and the fine quality of the Edison disc record.

"On the Saturday preceding Christmas our Edison disc department resembled a bargain counter in a department store, as, in addition to the regular clerks of the department, it was necessary to request several of the officials of the company, two members of the wholesale piano staff and several members of the retail piano warehouses to assist in taking care of our Edison patrons.

"The selling arguments on behalf of the Edison disc line are so varied and so numerous that the salesman is permitted to avail himself of a wide field in the presentation of his talk on the merits of the machines and records, but as a matter of fact a demonstration of one or two records of various types is sufficient to close the sale without any extended salesmanship. We are enthusiastic over the future of the Edison disc line in our house, and feel sure that 1914 will be an Edison disc year, as the consistent advertising of the disc product cannot fail to extract inquiries which become ready sales as soon as the machine is demonstrated."

SCHOOL CONCERT INTERESTS.

Pupils of North Union High School Enjoy Victrola Recital by Courtesy of P. W. Simon.

(Special to The Talking Machine World.)

UNIONTOWN PA., January 6.—One of the live-wire merchants in this city is P. W. Simon, the well-known Victor dealer, who is always on the lookout for opportunities to present the Victrola through mediums that are off the beaten track. In line with this policy Mr. Simon recently directed the giving of a concert in the auditorium of the North Union High School, at which the Victrola was featured. Last year each one of the Uniontown schools enjoyed a recital, but this was the first Victrola concert given in a township school. The 145 pupils assembled in the auditorium, and a program in two parts—the first half devoted to musical appreciation, and the second to popular concert—was produced. The concert was a marked success, due to Mr. Simon's careful supervision of all details.

DEALERS COMPLIMENT SERVICE.

Express Appreciation of Manner in Which the New York Talking Machine Co. Took Care of Their Requirements During Holidays.

"December 26 was truly a day of compliments from our many dealers," stated V. W. Moody, sales manager of the New York Talking Machine Co., 81 Chambers street, New York, the prominent Victor distributor. "Telephone calls, letters and personal interviews have been the mediums used by our clients to express their appreciation of the excellent care we have taken of them throughout this time of marked machine shortage.

"Our ability to satisfy all our dealers this season was due to our method of handling all requests and orders on a sound, reasonable basis. We made it a point this year to give everybody what they wanted and to give no dealer what he really did not want. We made this well-nigh ideal condition possible by means of telephone calls and personal conversations with our trade, emphasizing all the time that we would gladly co-operate with them in every possible way to best solve their selling problems. Although some of our dealers were not taken care of until the eleventh hour, the later machine arrivals were as promptly disposed of and as much appreciated as if they had been received in the first part of the season.

"This has been a record-breaking December for everybody. We are receiving many letters from our dealers telling of the excellent results they achieved this month, one letter on the top of this morning's mail reading as follows being a fair example: 'This was the greatest December I ever had. I am over \$3,000 ahead of last December, with another week to go. Best wishes to all.' This is from a small but aggressive dealer up-State.

"We have a very keen sense of appreciation of the patronage that our dealers have given us during the past year, not only during the holiday season but throughout the whole year. Every man in our organization has contributed to the work of co-operation we carried on in 1913, and our plans for 1914 include a still more detailed method of working in complete harmony and keeping in close touch with all our dealers."

NEW BOOTHS FOR BLACKMAN.

The Blackman Talking Machine Co., 97 Chambers street, New York, the well-known Victor and Edison distributor, has just added to its wareroom space two new booths, making ten in all. These new booths were completed two days before Christmas, and rendered valuable assistance in taking care of the holiday trade. The company is now utilizing all of the extra floor space which it acquired recently.

WOULD CURB ADVERTISEMENTS.

Minnesota Congressman Urges More Stringent Mail Laws to Prevent False Ads.

(Special to The Talking Machine World.)

WASHINGTON, D. C., January 9.—Laws preventing distribution through the mails of newspapers and periodicals that publish advertisements falsely representing articles proposed for sale were to-day advocated by Representative Steenerson, of Minnesota, before the House Inter-State Commerce Committee. Steenerson urged the enactment of Federal statutes prohibiting the sale or transportation of misbranded and misrepresented articles of commerce. He instanced numerous articles made in Germany, England and Japan which bore American names and were sold in this country as products of American labor.

The fundamental purpose of such a law, he explained, would be to instill honesty in business.

IMPORTANCE OF THE MOTOR

The Subject of Some Valuable and Informative Pointers in Circular Sent Out by the Victor Co.—Necessity of Regulation.

Under a recent date the Victor Talking Machine Co. sent out to its dealers an interesting letter on the proper adjustment of governor springs and barrel caps in order to permit of the regular running of motors. This letter treats in detail of the various causes of the irregular running of the motors, and mentions the different means that should be adopted to make the motor run true to form.

Among other things the company calls attention to the fact that the talking machine must be regulated more closely than a watch or clock, and should therefore be very carefully adjusted. It is suggested that it is unreasonable to expect an instrument which is supposed to reproduce the human voice or the most delicate tones of the violin in perfect time and tone to operate properly after being thrown about roughly by freight "hustlers" time and time again.

ENLARGE VICTROLA DEPARTMENT.

The Foster Piano Co., Troy, N. Y., which recently put in a large Victrola department under the management of Leslie C. Hathaway, has remodeled the ground floor of its building to permit of the installation of several sound-proof talking machine demonstrating booths. In the piano line the company handles the Knabe, Haines Bros., Foster and other lines of pianos and player-pianos.

OPEN "TALKER" DEPARTMENT.

The Gus Blass Co., Little Rock, Ark., has opened a talking machine department, with S. M. Field as manager. The Columbia line is handled.

CHEMISCHE
FABRIK

E. SAUERLANDT

FLURSTEDT
bei Apolda i. Th., Germany

The largest manufacturing plant in the world devoted exclusively to the manufacture of Master-Waxes and Master-Blanks for

Gramophone and Phonograph Recording

Sole Manufacturer of Wax "P." the best recording material for Berliner-cut.

A MAN SHOULD HAVE A CLEAR VISION OF HIS VOCATION

Says John Wanamaker, the Prominent Merchant, in a Recent Address Before the Leaders' Club of Philadelphia—Business Not a Matter of Mere Machinery—A Man Must Love His Business to Succeed in It—Must Be Something More Than Merely Making a Living.

The opinions of men who have scored a success in the business world are always valuable—that is, the views of practical men who have worked their way from the bottom to the top. Hence the recent address of John Wanamaker before the Leaders' Club of Philadelphia makes good reading because it gives a mental picture of the speaker and the elements that have gone to make him a leader in the commercial sphere. He said:

"Business is not a matter of machinery; it is not a great granite building; it is not iron and steel and rock; it is the human force that is in it. It is the man. What you are after, I am sure, is to see that every man becomes a better man and has a greater sense of responsibility and a larger vision of things that ought to be done.

"I would like to say to you that no business can be conducted from the outside. You cannot get it out of the newspaper or from some theory. It is the thing that is on the inside of it. It has got to be within us. You cannot learn it all in this convention. You cannot learn it all next year. It is something that must be in the human mind and in the human soul if it is going to come to anything.

"The brain and the heart of the organization are first of all the brain and heart of each individual. The best music box that was ever contrived is easily gotten out of order. You let in stand and it rusts. If you fail to wind it up in the right way it plays discord. The human heart and mind are like that. They have got to be wound up. They have got to be kept from rusting. You cannot think that you know it all.

The First Thing Is to Be a Man.

"Progress is the result of self-development. It implies self-direction. God never made a man just because he wanted one more man. He wanted you. He started you with a different shaped head, different face, different thoughts.

"When Garfield graduated from college the boys stood together talking. They said to him, 'Jim, what are you going to do?' He replied, 'The first thing I am going to do is try to be a man.' They then asked, 'Well, what about the rest of it? What are you going to do?' He said, 'I don't know. In the first place I intend to try to find out God's plan for my life and then to run along with it and not across it.'

"Did you ever hear that? That is worth your remembering—not to run across God's plan, because after all we are God's children, whether we are Jews or Gentiles, white or black. God is our Father; He is our helper and He wants us to succeed.

"I want to say to you again, progress is the result of self-development, self-direction of the talents and energies which were given to you. Someone else cannot manage your energies. I wish someone else could manage some of mine, but one cannot. We go zigzag and crooked before we know it. Something down inside of you, when you think of a wasted day, haunts you and makes you wish you could go back and do the day over.

Efficiency Is All-around Application.

"Efficiency, it seems to me, is an all-around application to the work in hand and untiring energy and patience. These to me are the foundations of success. Each man must understand the game as a whole. He cannot just pick up a little corner of it. He may do something, but I think it is an absolute necessity for a man to put the whole of himself into anything if he is going to get the success that his Heavenly Father wants him to have; that his mother wants him to have; that his company wants him to have.

"It is not a game to be played, a game to be enjoyed; not just enough to satisfy, but to do the very highest thing that you can. It is a wonderful inspiration to greater success for you. It is an influence on another man.

"There are some men that have genius, that can read a page of a book to look at it. Some men

get a great thought or vision and they believe they do not have to work. These visions will come, and they are capable of doing something very wonderful; but in a long life I have never seen great success like that. Here and there one may stand out prominently.

"I should say the first essential for any man to succeed in any business is to love it. If he does not love it he is likely to get tired. A man very easily drifts off to something else. The other side of the road looks better to him. When he gets there it is the same thing. You have got to love a business more than simply making a living or the opportunity to lay up some money.

"A man should have a clear vision of his vocation and manfully and planfully—not playfully—work it out."

REGULATING SIGN ADVERTISING.

An ordinance designed to do away with the cloth signs used to exploit special sales of doubtful merits has been put into effect in Portland, Oregon. The ordinance was backed by the local advertising club, and was originated at the suggestion of and under the direction of A. G. Clark, a member of the national vigilance committee of the Associated Advertising Clubs of America. It is called the cloth sign ordinance, and reads as follows:

"That it shall be unlawful for any person, firm or corporation to construct, maintain or tack any sign, banner or card constructed or made up in whole or in part of any combustible material, upon the outside walls, front, rear, sides or roof of any building or other surface, or over or upon any of the sidewalks within the city of Portland, excepting as provided in Section 2 hereof.

"Signs, banners and cards not exceeding twenty square feet in area are not prohibited by this ordinance; provided, however, that not more than one of such signs, banners or cards shall be constructed, maintained or tacked within every twenty lineal feet.

"Signs, banners and cards provided for in Section 2 of this ordinance shall be securely fastened and attached to the building or surface upon which they are placed. No sign, banner or card, as provided for in this ordinance, attached to the outside walls of any building, shall project higher than its blocking course or fire wall.

"Any person, firm or corporation violating any of the provisions of this ordinance shall, upon conviction thereof in the municipal court, be punished by a fine of not less than \$10 or more than \$250, or by imprisonment in the city jail not to exceed sixty days, or by both such fine and imprisonment.

"The police department is hereby authorized to remove any and all signs, banners or cards which are now in existence or which may be hereafter constructed, maintained or tacked in violation of the provisions of this ordinance."

TALKERS BY PARCEL POST.

So far as we know the first talking machine concern to advertise the shipping of talking machines by parcel post was the Crafts Piano Co., of Richmond, Va. No doubt others have fallen in line, and the business of shipping machines by parcel post will grow. The following facts concerning the growth of the parcel post business will be interesting:

It was announced recently from Washington that the profits to the Government from the operation of the new parcel post system during the calendar year 1913 would be about \$30,000,000. The new system became effective on January 1 last. It was estimated that the profits for the first year would be about \$15,000,000, but the actual figures now in possession of postal officials convince them that the profit, instead of being \$15,000,000, will be \$30,000,000 for the first year.

This will be interesting news to railway officials, who have been contending that their roads were entitled to extra remuneration for carrying the mails on account of the operation of the parcel post. It is said that, even assuming that the contention of the railroads was correct, there still would have been a good margin of profit at the end of the calendar year 1913 after the payment of extra remuneration to the roads. If a parcel post adjustment were made along the lines suggested by some of the railroads, probably not more than \$10,000,000 of this \$30,000,000 would be due to the railroads as extra pay. The total income from the parcel post for 1913 will be around \$80,000,000.

The whole question of railway mail pay, that is, compensation to the railroads for carrying the mails, is likely to be readjusted next year. Immediately after the meeting of Congress in regular session in December, a bill will be introduced providing for this readjustment. The measure is now being drafted. It will seek to establish an entirely new method of paying the railroads for carrying the mails and do away with the present archaic method of computing the payment to roads.

The name describes the needle and the needle fulfills its tone— The PURITONE Needle.

FURNISHED in Puritone or your own envelopes packed in different sizes. Quality guaranteed. Price popular. Dealers can secure a sample package free. Send jobber's name with letter. Remember, a quality needle will help you; it means a profit and a following.

THE following is a new selling idea for needles, packed exclusively by us:

Instead of selling 100 or 200 needles at once, sell a thousand. We pack 1,000 assorted needles in a box, each box containing 200 of Extra Loud, Loud Opera, Medium and Soft. This is the "Special" Dean Packing. You can sell 1,000 instead of 100 and thus get 10 times the business.

Want the Puritone Needle samples?

JOHN M. DEAN
PUTNAM, CONN.

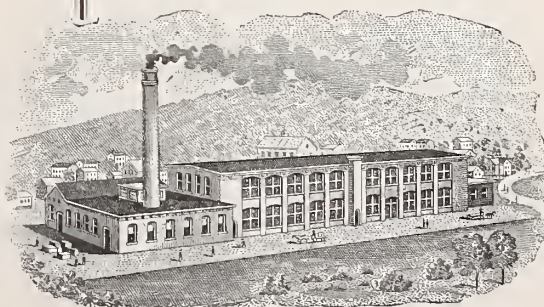

LATEST PATENTS RELATING TO TALKING MACHINES AND RECORDS

(Special to The Talking Machine World.)

WASHINGTON, D. C., January 10.—PHONOGRAPH. Frank L. Dyer, Montclair, N. J., assignor to the New Jersey Patent Co., West Orange, N. J. Patent No. 1,081,374.

This invention relates to phonographs, and the chief object thereof is to provide a phonograph reproducer whereby cylindrical sound records of different diameters may readily be brought into adjusted position to be engaged by a reproducer stylus.

When it is desired to bring a cylindrical sound record of an external diameter different from that of a record for the reproduction of which the phonograph is adjusted into engagement with the reproducing stylus, the desired end may be encompassed either by movement of the phonograph mandrel or record-carrying support into proper position for the co-action of the record carried thereby with the reproducer stylus, or, the phonograph mandrel being stationary, the position of the reproducer may be adjusted so that the stylus carried thereby is brought into operative relation to the new record. In a companion application (Serial No. 509,040) filed on even date herewith, there are disclosed means operating by

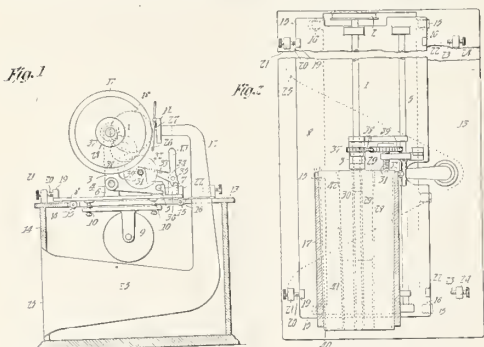

the last-named principle, the mandrel having no movement toward and away from the reproducer, while the latter is carried by a sound conveying tube pivoted at such a point that the reproducer stylus may be brought into operative relation with records of different diameters by pivotal movement of this tube. In the present application, the reproducer is held in fixed position, while the adjustment for different sizes of records is obtained by movement of the phonograph mandrel toward and away from the reproducer.

Having this object in mind, this invention consists in the construction of parts and combinations of elements necessary or desirable for the carrying out of the desired objects.

Figure 1 represents an end elevation of a phonograph embodying this invention, the inclosing cabinet being shown in section; and Fig. 2 represents a top plan view of the same, a record of large diameter being shown in cross section.

PHONOGRAPH. Peter Weber, Orange, N. J., assignor to the New Jersey Patent Co., West Orange, N. J. Patent No. 1,081,352.

This invention relates to phonographs, and the object thereof is, broadly speaking, the production of a compact and efficient device for the conveying and dissemination of sound in the reproduction thereof.

More specifically, there is provided a structure wherein the cover for the phonograph is pivoted, and when in open position may be supported in such position that a sound conveying tube connected with the neck of the reproducer may deliver the sound waves set up by the vibration of the reproducer diaphragm into the interior of the said cover. The cover is provided in its interior with sound deflecting means, and means for conveying the sound so deflected smoothly to the open or bottom end of the cover, this sound conveying means within the body of the cover being of such a character as to amplify the sound.

Preferably, the open end of the cover, when the latter is in its open position, is forwardly directed, the cover being supported in a position at right angles to that in which it is placed when the cover is closed. The sound conveying tube connected to the reproducer is preferably supported within the cover and directs the sound waves against the inner side of the top of the cover, whence they are deflected forwardly with amplification to the open end of the cover and thence to the audience. By this construction, sound conveying and amplifying means of sufficient amplification are provided in a less space than would be

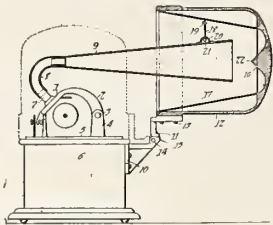

necessary if the sound amplifying horn were all in one structure, as is common, and a compact structure is thereby attained.

TONE-CLARIFYING ATTACHMENT FOR SOUND REPRODUCING OR TRANSMITTING INSTRUMENTS. Cora Stetson Butler, Cleveland, O. Patent No. 1,081,719.

This invention relates generally to tone-clarifying devices for use with sound producing instruments or machines, and has particular reference to a device of this character which is adapted to be employed within sound reproducers of prevailing types of gramophones, telephones and other such machines or instruments, and is capable of being applied thereto as an attachment without the necessity of making any change or modification in the sound reproducer.

The objects of this invention are to provide as an attachment for the sound reproducers of gramophones, telephones and other sound reproducing machines or instruments a tone-clarifying device which may be quickly and conveniently applied to existing types of sound reproducers; which controls the vibrations of the diaphragm, preventing its acting too violently and continuously and thereby eliminating the fluctuation or echoing effect of the tone which is usually present in the operation of the aforesaid machines or instruments; which is very durable; and which is simple and economical of production.

It is commonly known that, accompanying tones reproduced by machines or instruments of the

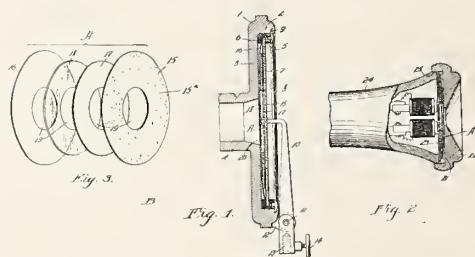

above class, there is an unpleasant grating or rasping sound which detracts materially from musical reproductions, and, in the case of the reproduction of speech results in a confusion of inarticulate sounds, and this very displeasing quality is most noticeable in tones of high pitch. In fact, it appears to increase in direct proportion to the rise in pitch, which would seem to prove that, as the vibrations of the diaphragm become more rapid and the sound waves produced thereby shorter, following each other in more rapid succession, there becomes an agitated condition of air and sound waves within the sound reproducer. In other words, the principal sound waves seem to be surmounted by smaller sound waves or false vibrations or fluctuations, the resulting effect of which is nothing more than a noise. It would seem to follow from this that if certain means were introduced in the sound reproducer which would obviate this confusion by keeping under

control the diaphragm and consequently the sound waves resulting directly from the vibrations thereof and which, at the same time, would interfere in no way with the delicate operation of the diaphragm, some, if not all, of the disagreeable qualities which are incidental to such instruments would be eliminated.

Whether the above theory is correct or not, it has been found by experiments that, by placing within the sound reproducers between the diaphragm and the parallel wall of the casing a device comprising a plurality of properly arranged discs of various sizes and materials, the reproduction of the tones are cleared of all impurities resulting from the false vibrations or fluctuations of the diaphragm, and the effect is practically the same in richness and clearness as the original production.

Figure 1 is a central vertical section through a sound box of a gramophone having a device of the invention applied thereto; Fig. 2 is a sectional detail of a telephone receiver, illustrating the manner in which the device is used with such instruments; and Fig. 3 is a perspective of the various elements which constitute the device, separated in order to show their relative sizes and positions.

DOUBLE-POINTED REPRODUCING STYLUS FOR TALKING MACHINES AND HOLDER THEREFOR. Edward T. Condon, Jr., New York, N. Y. Patent No. 1,080,328.

The invention has for its object to provide a one-piece reversible stylus having oppositely pointed ends, one of which may be of different character from the other if desired; and it has for a further object to suitably protect the inactive ends of such stylus.

Figure 1 is a front elevation of a sound box, stylus holder, partly in section, and the stylus

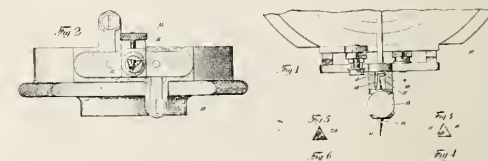

held thereby. Fig. 2 is a view of the under side thereof. Figs. 3 and 4 are respectively a plan and elevation of a guard for the stylus. Figs. 5 and 6 are respectively a plan and elevation of another form of guard.

Similar characters of reference designate corresponding parts throughout the several views.

The invention relates to a novel reproducing stylus or phonographic needle as employed in connection with rotating cylinders or discs in talking machines, and to a novel holder therefor.

DIAPHRAGM FOR SOUND BOXES. Pliny Catucci, Newark, N. J., assignor to Meisselbach & Bro., same place. Patent No. 1,080,953.

This invention relates to diaphragms for sound boxes used for recording and reproduction of sound upon the well-known phonograph, and more particularly relates to the form and structure of the diaphragm itself. Ordinarily, such diaphragms are made of glass, mica, celluloid, a thin sheet metal, as copper, bronze, etc., or any thin elastic membrane. It has been proposed to construct these diaphragms with concentric annular corrugations, or with radial corrugations, with the idea that such corrugations will more readily gather up and respond to certain sound vibra-

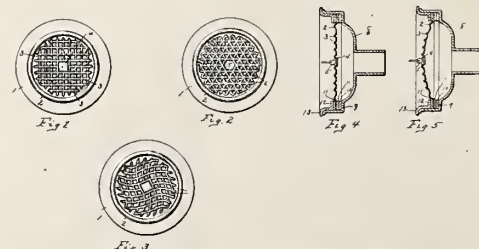

tions which a plain disc is incapable of responding to. From a series of experiments it has been discovered that by producing in the face of a metallic disc or diaphragm what is termed a grid formation of corrugation more delicate sound

vibrations can be recorded and reproduced than has heretofore been possible by the use of any of the special forms of diaphragms. In some cases it has been found that one shape or form of grid corrugation will respond more readily to certain delicate sound vibrations than a grid of another character, while such other grid will respond to sound vibrations which are apparently too gross for other forms of grid. Again, in some cases it is advisable to distort the disc from a true plain into a concavo-convex contour.

Fig. 1 illustrates the face of a diaphragm made in accordance with this invention with the rectangular form of grid. Fig. 2 is a similar view showing a triangular form of grid. Fig. 3 is a similar view wherein the grid is made up of curved corrugations so as to form the complete figure into rhombuses. Fig. 4 illustrates in cross section a sound box with a flat disc made in accordance with this invention. Fig. 5 is a view similar to Fig. 4, but having the diaphragm concaved outwardly.

TALKING MACHINE. Walter Hansen Rawles, London, Eng. Patent No. 1,080,231.

This invention relates to diaphragm carriers for talking machines and the like and is especially intended for use in that class of machine adapted to the immediate reproduction of matter recorded. In particular it is well adapted for use in the machine described in United States Patent No. 1,027,350.

The invention has for its objects to improve the working of such machine and to facilitate the general process of recording and reproduction.

It is known to provide a diaphragm carrier upon which reproducing and recording diaphragms are mounted upon a pivot at right angles to the plane of the diaphragms in order that either may

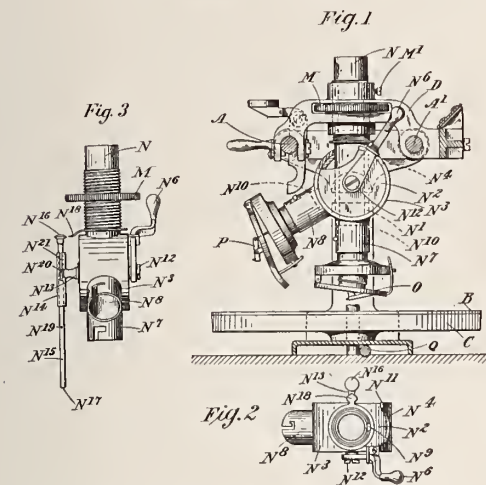

be swung around into position directly in front of the end of the speaking tube.

The present invention provides in a talking machine a diaphragm carrier comprising a holder for reproducing and recording diaphragms so supported as not only to be capable of being turned about an axis parallel with the planes of the said diaphragms to bring either into operative position upon the record tablet, but also to provide a straight, unbroken closed-in passage from the speaking tube to whichever diaphragm is in operative position.

The invention also provides for the employment of a fine adjustment for the diaphragm carrier whereby the recording and the reproducing stylus may be adjusted in relation to the recording tablet, and for the amount of adjustment necessary to be automatically indicated.

In the accompanying drawings, Fig. 1 is a side elevation of a disc machine upon which a diaphragm carrier according to the present invention is mounted. Fig. 2 is a plan of the diaphragm carrier dismantled from the machine, and Fig. 3 is a corresponding end elevation.

SOUND BOX. Pliny Catucci, Newark, N. J., assignor to A. F. Meisselbach & Bro., same place. Patent No. 1,080,954.

This invention relates to that class of sound boxes for the use in phonographs and talking machines wherein the disc record is commonly used,

although it may be used in connection with machines using the cylinder record; it relates more particularly to the improved form of stylus lever and its method of attachment to the body of the sound box, and is directed more particularly to the simplification of such parts with a view to the improvement of the results to be obtained, as well as the reduction of the cost of manufacture and quickness and facility of adjustment.

In the accompanying drawings forming a part of this specification, Fig. 1 is a front elevation of the complete sound box. Fig. 2 is a similar view with clamping ring and diaphragm removed. Fig. 3 is a side elevation of the complete box. Fig. 4 is a similar view of the box body. Fig. 5 is an enlarged sectional view on line 5-5 of Fig. 1. Fig.

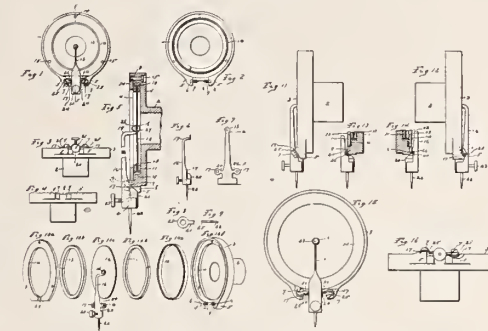

6 is a side view of the stylus lever detached. Fig. 7 is a plan view of the stylus lever blank. Fig. 8 is a plan and Fig. 9 is a side elevation of the clamping washer. Figs. 10a, 10b, 10c, 10d, 10e and 10f are respectively perspective views of the several parts of the sound box arranged in the order in which they are assembled to form the complete box. Figs. 11 and 12 are respectively right and left side elevations of a modified form of sound box. Figs. 13 and 14 are sections through the right and left supporting lugs. Fig. 15 is a front elevation and Fig. 16 is an under plan view of said modified form.

STYLUS FOR SOUND-REPRODUCING MACHINES. James W. Owen, Lansdowne, Pa., assignor to the Victor Talking Machine Co., Camden, N. J. Patent No. 1,080,924.

This invention relates to styli for sound reproducing machines, and particularly to those styli or needles which are adapted to be used in talking machines to reproduce sound from commercial sound record tablets.

It is customary, in reproducing sound in a sound-reproducing machine from sound record tablets with the use of an ordinary steel stylus or needle, to use the steel stylus but once, and when a steel stylus has once been employed in reproducing sound from a given tablet it is usual to throw it away and to replace it with a new steel stylus to reproduce sound from the same or another tablet.

After a steel stylus has been used to reproduce sound from a sound record tablet, the tip or point of the stylus is always worn to an appreciable extent and a sharp edge is generally formed thereon which tends to cut or unduly wear away the walls of the groove of another tablet, especially when that groove of the second tablet is not exactly of the same shape and size in cross-section as that of the first tablet, and particularly if that worn stylus would be placed at any other angle or in any other position than that which it occupied during the reproduction of sound in the first sound record tablet.

The object of this invention is to obviate the necessity of changing the stylus for each reproduction of sound from a sound record tablet, and to provide a stylus which may be used to reproduce sound from a large number of different tablets without substantial injury to the tablets. It has been discovered that when a sound-reproducing stylus is composed of tungsten, that stylus may be used repeatedly in reproducing sound from different sound record tablets without the necessity of re-forming the point of the stylus and without substantial injury to the walls of the sound groove.

Tungsten is considerably softer than steel, and

generally speaking, would be expected to exhibit a much greater wear during the reproduction of sound from a sound record tablet, due to the abrasive action of the material of the sound record tablet upon that portion of the stylus in engagement with the tablet than would steel. It is found, however, that when a stylus is made of tungsten and is used in reproducing sound from a commercial sound record tablet, it exhibits peculiar and unexpected properties. Thus, during the first few revolutions of a sound record tablet, the groove of which is in engagement with a stylus made of tungsten, a new tungsten stylus wears more rapidly than does a steel needle of the same size and shape, but after that the tungsten stylus wears much more slowly than such a steel stylus does. As a matter of fact, after the first few revolutions of the sound record tablet, and the first wear has appeared on the surface of the stylus, the stylus wears so slowly as to be substantially negligible. The amount of wear which a tungsten stylus exhibits during the reproduction of sound from commercial sound records may be more readily understood when it is stated that when a steel needle is run only two or three times across a record the point of the steel stylus generally wears down sufficiently to form a shoulder and will injure the surface of the sound record groove to such an extent as will often render the reproduction of sound from the record very indistinct. A tungsten stylus, however, may be run over the same record 300 or 400 times before the reproduction begins to get indistinct.

After the tip of a tungsten stylus under the abrasive action of the material forming the sound record tablet has worn sufficiently to substantially fit the groove, the wear on the tip of a tungsten stylus is very slight. It would appear that after a certain amount of bearing surface between the end of the stylus and the walls of the sound record groove has once been obtained, the wear of the tungsten stylus is exceedingly slow.

Fig. 1 represents the sound box of a sound-reproducing machine provided with a stylus of

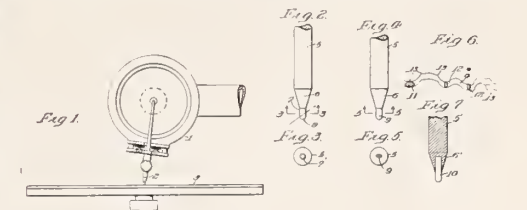

tungsten in engagement with a sound record tablet, the stylus being shown on an enlarged scale for the sake of clearness; Fig. 2 is a greatly enlarged view of one form of the improved tungsten stylus; Fig. 3 is a cross-sectional view through the tip of the stylus shown in Fig. 2; Figs. 4 and 5 show a modified form of tungsten stylus in which the tip is elliptical in cross-section; Fig. 6 is a diagrammatic view indicating a sound record groove on a greatly enlarged scale, and a cross-sectional view of the tips of the two forms of styli shown in Figs. 2 and 4 in the plans of the surface of the sound record tablet, and Fig. 7 is a further modified form of stylus.

No honest purpose is ever wasted and no honest desire ever remains unanswered.

60 YEARS' EXPERIENCE

PATENTS

TRADE MARKS
DESIGNS
COPYRIGHTS & C.

Anyone sending a sketch and description may quickly ascertain our opinion free whether an invention is probably patentable. Communication strictly confidential. HANDBOOK of Patents sent free. Oldest agency for securing patents. Patents taken through Munn & Co. receive special notice, without charge, in the

Scientific American.

A handsomely illustrated weekly. Largest circulation of any scientific journal. Terms, \$3 a year; four months, \$1. Sold by all newsdealers.

MUNN & Co. 361 Broadway, New York
Branch Office, 235 F St., Washington, D. C.

RECORD BULLETINS FOR FEBRUARY, 1914

VICTOR TALKING MACHINE CO.

No.	POPULAR SONGS.	Size.
17501	You Need a Rag (Esrom-Morse)..... American Quartet	10
	Down in Monkeyville (Clarke-Leslie-Morse).... Arthur Collins-Byron G. Harlan	10
17503	I'm on My Way to Mandalay (Bryan-Fischer).... Oakland-Campbell-Burr	10
	Dream Days (Chas. L. Johnson).... Will Oakland	10
17504	By the Old Wishing Well (Walsh-Sherman).... Albert Campbell-Henry Burr	10
	Just You and I and the Moon, from "Follies of 1913" (Buck-Stamper).... Lillian Davis	10
17507	Take Me Back (Irving Berlin).... Henry Burr	10
	You Did (You Know You Did) (Gilbert-Muir).... Albert Campbell-Henry Burr	10
17514	At that Bully Woolly Wild West Show (Leslie-Clarke-Abrahams).... Peerless Quartet	10
	The Pussy Cat Rag (Kitty, Kitty, Kitty) (Allen-Daly-Allen).... Peerless Quartet	10
17516	Sit Down (You're Rocking the Boat) (Jerome-Clarke-Schwartz).... Billy Murray	10
	Your Mother's Gone Away to Join the Army (Gray-Walker).... Billy Murray	10
17517	Flow Along, River Tennessee (To the Home of the Girl I Love) (Bryan-Gumble-Wells).... Albert Campbell-Henry Burr	10
	I'm Afraid I'm Beginning to Love You (Goodwin-Brown).... Helen Clark-Billy Murray	10
EDUCATIONAL RECORDS.		
17510	1—Ma's Little Pigs, from "Folk Dances and Singing Games;" 2—Our Little Girls, from "Dances of the People" (Elizabeth Burchenal) Victor Military Band	10
	Fryksdalspolska (Old Swedish), from "Folk-Dance Music" (Burchenal-Crampton).... Victor Military Band	10
17511	Trekarispolska—Three Men's Polka, from "Dances of the People" (Elizabeth Burchenal) Victor Military Band	10
	Rigs O'Marolow—Stick Dace, from "Morris Dance Tunes" (Sharp-Macilwaine).... Victor Military Band	10
17512	The Drum (Eugene Field) (Recitation).... Cora Mel Patten	10
	The Duel, from "Love Songs of Childhood" (Eugene Field) (Recitation).... Cora Mel Patten	10
17513	1—The Cuck-Coo Clock; 2—Slumber Song, from "Seven Little Songs" (Pfirshing-Schaefer).... Elizabeth Wheeler	10
	1—The Secret; 2—Old Chanticleer; 3—The Hungry Windmill, from "Dutch Ditties" (Anice Terhune).... Elizabeth Wheeler	10
35350	Jest 'Fore Christmas, from "Love Songs of Childhood" (Eugene Field).... Cora Mel Patten	12
	1—The Doll's Wooing; 2—The Sugar Plum Tree (Eugene Field).... Cora Mel Patten	12
NEW DANCE RECORDS.		
17489	On the Honeymoon Express—Medley Two-step or Turkey Trot.... Victor Military Band	10
	The Junk Man Rag—One-step or Two-step (Roberts).... Victor Military Band	10
35346	Isle d'amour—Waltz Hesitation (Leo Edwards).... Victor Military Band	12
	The Flower Garden Ball—Turkey Trot.... Victor Military Band	12
35347	Hydropaten Waltz (Gung'l) (with bells).... Conwaw's Band	12
	Espana—Waltz Hesitation (Waldteufel).... Victor Military Band	12
35348	He'd Have to Get Under—Get Out and Get Under—One-step or Turkey Trot.... Victor Military Band	12
	There's a Girl in the Heart of Maryland—Medley Two-step or Turkey Trot.... Victor Military Band	12
17508	Stomp Dance—Turkey Trot (C. I. Stewart).... Victor Military Band	10
	San-Fran-Pan-American—Two-step (Joel P. Corin).... Victor Military Band	10
STANDARD VOCAL NUMBERS.		
	Lambert Murphy-Reinald Werrrenath, Purple Label.	
60108	La Boheme—Ah, Mimi, tu n'ira (Ah, Mimi, False One) (Act IV).... In Italian.... Puccini	10
	Double-Faced.	
17498	Alice, Where Art Thou (Ascher).... C. W. Harrison	10
	Come Into the Garden, Maud (Tennyson-Balfe) Charles W. Harrison	10
17499	Happy Day (Rimbault) (Gospel Hymn).... Trinity Choir	10
	The Precious Name (Baxter-Doane) (Gospel Hymn).... Trinity Choir	10
17500	Benny Havens, Oh! (West Point Song).... American Quartet	10
	Army Blue (West Point Song) American Quartet	10
17488	On an Afternoon in June (J. W. Fulton) (with Bird Warbling).... Helen Clark-Joe Belmont	10
	The Nightingale (J. W. Fulton) (with Bird Warbling).... Byron G. Harlan-Joe Belmont	10
NEW INSTRUMENTAL RECORDS.		
	Blue Label	
55044	Dance of the Hours, from "La Gioconda" (Ponchielli).... Victor Herbert's Orchestra	12
	Kamennoi-Ostrow (Rève Angélique) (Rubinstein) Victor Herbert's Orchestra	12
	Black Label Records.	
17493	Uncle Tom's Cabin (Lampe) (A Dream Picture of the Old South).... Conway's Band	10
	Folks Up Willow Creek—March (Carlton) (Medley March of Old-Time Tunes).... Conway's Band	10
17515	La Golondrina (Serradell) (The Swallow).... Victory Military Band	10
	Perjura Danza—Mexican Dance (Fickle Maiden) (Miguel Lerdo do Tejada).... Victory Military Band	10
17506	International Rag (Irving Berlin).... Pietro Deiro	10
	Sailing Down Chesapeake Bay—Medley.... Pietro Deiro	10
35345	Bridal Rose Overture (Lavallée).... Pietro Deiro	12
	Stradella Overture (Flotow).... Pietro Deiro	12
MUSICAL COMEDY AND OPERETTA HITS.		
35349	Gems from "The Little Café" (McLellan-Caryll) Victor Light Opera Company	12
	Gems from "The Purple Road" (De Gresac-Duncan-Reinhardt-Peters).... Victor Light Opera Co.	12
35336	Gems from "When Dreams Come True" (Bartholomae-Hein).... Victor Light Opera Company	12
	Gems from The Madcap Duchess (Stevens-Herbert).... Victor Light Opera Company	12
17490	Just Because It's You (McLellan-Caryll) from "The Little Café".... Elsie Baker	10
	You and Only You (Herbe-Briquet-Phillips) from "Adele".... Elsie Baker-Fred'k Wheeler	10
17509	Isle d'amour (Carrol-Edwards) (Introduced in "Follies of 1913").... Olive Kline	10

	A Little Love, a Little Kiss (Un peu d'amour) (Leo Silésu).... Charles W. Harrison	10
NEW DOUBLES OF FAVORITE SINGLE RECORDS.		
35343	Gems from "Cavalleria Rusticana" (Mascagni).... Victor Opera Company	12
	Gems from "Pagliacci" (Leoncavallo).... Victor Opera Company	12
35344	Hearts and Flowers—Intermezzo (Tobani).... Victor Concert Orchestra	12
	Glow Worm Idyl (Paul Lincke).... A. Pryor's Band	12
THE RED SEAL LIST.		
	Enrico Caruso, Tenor. In Italian.	
88458	Cavalleria Rusticana—Addio alla madre (Turid-du's Farewell to His Mother).... Mascagni	12
	Nellie Melba, Soprano and Jan Kubelik, Violinist. In French. Pianoforte by G. Lapiere.	
89074	Il Re Pastore—L'amerò sarò costante (Aminta's Air from "The Shepherd King").... Mozart	12
	Nellie Melba, Soprano. In French. Pianoforte by Gabriel Lapiere.	
88455	John Anderson, My Jo.... Robert Burns	12
88456	1—Romance.... Bouquet	12
	1—Mandoline.... Debussy	12
	Johanna Gadski, Soprano. In German.	
87167	Die Walküre—Du bist der Lenz (Thou Art the Spring) (Act 1).... Wagner	10
	Ernestine Schumann-Heink, Contralto. In German.	
87170	Im Kahne (In the Boat) Op. 60, No. 2 (Poem by Vilhelm Krag, 1871).... Edvard Grieg	10
	Maud Powell, Violinist. Pianoforte by George Falkenstein.	
74354	Minuet.... Boccherini	12
74355	Kol Nidrei, Op. 47.... Bruch	12
	Jan Kubelik, Violinist. Pianoforte by George Falkenstein.	
74367	Romanza Andaluza (Spanish Dance No. 3) Op. 22.... Sarasate	12
74370	Finale from Second Concerto, Op. 22. Pianoforte by Gabriel Lapiere.... Wienawski	12
	Emilio de Gogorza, Baritone. Orch. accomp. and pianoforte by Henri Gilles.	
88447	1—Don Giovanni—Serenata, Deh vieni alla finestra. (Open Thy Window) (Act II). In Italian.... Mozart	12
	2—Damnation of Faust—Serenade Mephistopheles (n' French).... Berlioz	12
	George Hamlin, Tenor. In English.	
74378	Loves Sorrow.... Shelley	12
	Daniel Beddoe, Tenor. In English.	
64391	A Moonlight Song.... Mills-Cadman	10
	Evan Williams, Tenor. In English.	
64389	Just a Wearyin' for You.... Stanton-Jacobs-Bond	10
	Clarence Whitehill, Baritone. In English.	
64388	Uncle Rome (The Old Boatman). Weeden-Homer	10

COLUMBIA GRAPHOPHONE CO.

SYMPHONY DISC RECORDS.		
Olive Fremstad Sings Wagnerian Numbers.		
Double.	12-in. Records.	Single.
A5521	Tristan and Isolde (Wagner). "Isolde's Lie-bestod" (Isolde's Love Song). In German, with orch.	30707
	Don Carlos (Verdi). "O Don Fatale" (O Fatal Gift). In Italian, with orch.	36807
A1451	Die Walkure (Wagner). "Ho-Jo-To-Ho... (Brunnhilde's Battle Cry). In German, with orch.	
	Die Walkure (Wagner). "Du bist der Lenz" (Spring Now Is Here). In German, with orch.	
12-IN. SYMPHONY DOUBLE-DISC RECORD.		
A5519	O Divine Redeemer (Foote). Chas. W. Clark, Baritone, orch. accomp.	
	Elijah (Mendelssohn). "It Is Enough." Chas. W. Clark, Baritone, orch. accomp.	
10-IN. SYMPHONY DOUBLE-DISC RECORD.		
	Two American Songs by Bernice De Pasquah.	
A1446	The Last Dance (Ware). In English, with orch.	
	Call Me No More (Cadman). In English, with orch.	
10-IN. BLUE-LABEL DOUBLE-DISC RECORDS.		
A1445	Marche Mignonne (Poldini). Leo Ornstein, pianist. Papillon (Butterfly) (Grieg). Leo Ornstein, pianist.	
A1449	Orpheus (Gluck). Dance of the Blessed Spirits. George Barrere, flautist, orch. accomp.	
	l'Arlesienne Suite, No. 2 (Bizet) Minuet. Geo. Barrere, flutist, orch. accomp.	
A1450	Sing, Smile, Slumber (Serenade) (Gounod). William Place, Jr., Mandolin Solo.	
	Souvenir of Venice (Place). William Place, Jr., Mandolin Solo.	
12-IN. BLUE-LABEL DOUBLE-DISC RECORDS.		
A5516	The Huckleberry Bough (Bishop). Mildred Potter, Contralto, orch. accomp.	
	Rocked in the Cradle of the Deep (Knight). Frank Croxton, Bass, orch. accomp.	
A5518	In the Sweet Bye-and-Bye. Columbia Mixed Quartet with organ accomp.	
	A Thousand Years. Columbia Mixed Quartet, with organ accomp.	
A5520	The Serenade (Herbert). Vocal Gems. Columbia Light Opera Company, orch. accomp.	
	The Serenade (Herbert). Selections. Prince's Orchestra.	
10-IN. DOUBLE-DISC RECORDS.		
A1447	Barney O'Hea (Lover). William Thomas, Tenor, orch. accomp.	
	When You and I were Young, Maggie. Archie Anderson, Baritone, orch. accomp.	
A1448	Rendezvous—Intermezzo (Aletter). Prince's Orchestra.	
	Un peu d'Amour (A Little Love, A Little Kiss) (Silésu). Prince's Orchestra.	
A1389	Marietta Two-step and Polka (Sterny-Courquin). Ellery Band.	
	La Feria Suite (Lacome). "La Zarzuela." Ellery Band.	
12-IN. DOUBLE-DISC RECORDS.		
A5515	'Tis Not True (Non e ver) (Matti). Mrs. A. Stewart Holt, Contralto. Violin and harp accomp: Will You Love Me When I'm Old? (Ford). Mrs. A. Stewart Holt, Contralto. Violin and harp accomp.	
A5517	All Souls' Day (Lassen). Cornet solo by Charles Leggett. Band accomp.	
	Song Without Words (Goltermann). 'Cello Solo by Jean Schwiller.	
DOUBLE-DISC RECORDS.		
The Latest Popular Dances.		
A1458	Tres Chic (Caslar). Prince's Band. 10-in.	
A1457	He'd Have to Get Under, Get Out and Get Under (Abrahams). Prince's Band. 10-in.	
A5524	L'Amour—One-step (Christine). Prince' Band. 12-in.	
	Hesitation Waltz (Shaw). Prince's Orchestra. 12-in.	

A5525	Dreaming—Waltz (Joyce). Prince's Orchestra. 12-in. Isle d'Amour—Waltz (Edwards). Prince's Band. 12-in.
A5526	La Rumba—Tango (Brymn). Prince's Band. 12-in. Maurice Irresistible—Tango (Logatti). Prince's Band. 12-in.
FEBRUARY SONG HITS.	
A1452	On a Good Old-Time Sleigh-Ride (Gumble). Peerless Quartet, orch. accomp. 10-in. Flow Along, River Tennessee (Gumble and Wells). Albert Campbell, 1st Tenor and Henry Burr, 2d Tenor, orch. accomp. 10-in.
A1453	Down in Chattanooga (Berlin). Arthur Collins, Baritone, and Byron G. Harlan, Tenor, orch. accomp. 10-in. Tra, La, La, La (Berlin). Arthur Collins, Baritone, and Byron G. Harlan, Tenor, orch. accomp. 10-in.
A1454	I Miss You Most of All (Monaco). Manuel Romain, Counter-Tenor, orch. accomp. 10-in. Would You Take Me Back Again? (Morris). Manuel Romain, Counter-Tenor, orch. accomp. 10-in.
A1455	Little Church Around the Corner (Carroll). Nora Watson, Contralto, and Henry Burr, Tenor, orch. accomp. 10-in. I'm Afraid I'm Beginning to Love You (Goodwin and Browne). William Halley, Tenor, orch. accomp. 10-in.
A1456	I'm Just Crying for You (McCarthy and Monaco). Ed. Morton, Baritone, orch. accomp. 10-in. Daddy Did a Wonderful Thing (Meyer). Billy Watkins, Tenor, orch. accomp. 10-in.
A1457	He'd Have to Get Under, Get Out and Get Under (Abrahams). William Halley, Tenor, orch. accomp. 10-in. Pussy Cat Rag (Gill). Ada Jones, Soprano, and Peerless Quartet, orch. accomp. 10-in.
A5522	Little Café (Caryll). "Just Because It's You." Grace Kerns, Soprano, and chorus, orch. accomp. 12-in. Little Café (Caryll). Waltzes. Prince's Orchestra. 12-in.
A1459	Madcap Duchess (Herbert). "Love Is a Story That's Old." Agnes Kimball, Soprano, and Chorus, orch. accomp. 10-in. Madcap Duchess (Herbert). Selections. Prince's Orchestra. 10-in.

THOMAS A. EDISON, INC.

REGULAR LIST.	
2145	Aida March (G. Verdi).... Edison Concert Band
2146	The Kerry Dance (James L. Mollov) Soprano with orch. accomp. Elizabeth Spencer
2147	On the Banks of the Wabash, Far Away (Paul Dresser) Baritone and chorus, orch. accomp. Vernon Archibald and Chorus
2148	Kiss Me Good-night (Goodwin and Brown). Comic song, orch. accomp. Billy Murray
2149	The Nightingale (Ed. Mollenhauer) Piccolo orch. accomp. Henry Heidelberg
2150	When the Twilight Comes to Kiss the Rose Good-night (Henry W. Petrie) Tenor, orch. accomp. George Wilton Ballard
2151	Sweet Anna Marie (Theodore Morse) Tenor duet, orch. accomp. A. H. Campbell and I. Gillette
2152	(a) A Little Christmas Basket; (b) Howdy, Honey! Howdy! (Paul Lawrence Dunbar). Reading. Edward Sterling Wright
2153	(a) When de Co'n Pon's Hot; (b) 'Possum. (Paul Lawrence Dunbar). Reading. Edward Sterling Wright
2154	Our Volunteers Waltz (Wm. H. Santelmann).... United States Marine Band
2155	Would You Take Me Back Again? (Alfred Solomon) Tenor, orch. accomp. Manuel Romain
2156	There's Lots of Stations on My Railroad Track (Leo Edwards) Conversational duet. Ada Jones and Billy Murray
2157	Ruy Blas Overture (Mendelssohn).... Victor Herbert and His Orchestra
2158	Samson and Dalila—My Heart at Thy Sweet Voice (Saint-Saens). Contralto, orch. accomp. Mary Jordan
2159	Underneath the Tango Moon (Harry Carroll). Orch. accomp. A. Collins and Byron G. Harlan
2160	Flee as a Bird (Mrs. S. M. B. Dana). Contralto, sacred, orch. accomp. Helen Clark
2161	Tango—La Bella Cubanera (M. L. Lake). For dancing. National Promenade Band
2162	How Long Have You Been Married? (Rennie Cormack). Comic song, orch. accomp. Billy Murray
2163	Ever of Thee (Foley Hall). Violin, violoncello, flute and harp. Venetian Instrumental Quartet
2164	Just Because It's You—The Little Café (Ivan Carvill) Soprano, orch. accomp. Elizabeth Spencer
2165	Tres Chic One-step (Dan H. Casler) For dancing. National Promenade Band
2166	The "Honest" Hold-up Man and "Billy Beans" Vaudeville specialty. Murray K. Hill
2167	Dinah (Henry I. Marshall) Male voices, orch. accomp. Peerless Quartet
2168	When It's Springtime in Virginia (Ernie Erdman) Baritone, orch. accomp. O. J. McCormack
2169	Under the Double Eagle March (J. F. Wagner) New York Military Band
2170	Saw Ye My Saviour—Communion Hymn (Mary Baker G. Eddy). Christian Science Hymn, organ accomp. Edison Mixed Quartet
2171	Dance of the Hours—La Gioconda (Ponchielli) New York Military Band
2172	'Tis But a Little Faded Flower (J. R. Thomas) Tenor and Baritone, orch. accomp. John Young and Frederick J. Wheeler
2173	Lead Me to That Beautiful Band (Goetz and Berlin) Coon song, orch. accomp. Stella Mayhew
2174	King Karl March (C. L. Unrath) New York Military Band
FOUR POLK MILLER RECORDS.	
2175	The Bonnie Blue Flag. Banjo accomp.
2176	Laughing Song. Guitar accomp.
2177	What a Time. Guitar accomp.
2178	The Watermelon Party. Guitar accomp.

NEW EDISON DEALERS DOWN EAST.

Edison disc dealers have recently been installed in Keene, N. H., and Brattleboro, Vt., and other points in these States.

The well-known firm of A. W. Dickerman, Church street, has the line in Keene.

Many a man's best friends are those who know him least.

\$ \$ \$ \$ \$ \$ \$ \$ \$

\$ \$ \$

\$ \$ \$

\$ \$ \$

\$ \$ \$

\$ \$ \$

READE your trade paper! Get The Talking Machine World regularly—It is worth many times to you its annual cost.

There is but one talking machine paper covering this entire industry, and it is admitted by all that it is of great aid to the dealers in every part of this country.

New economic conditions make certain knowledge necessary on the part of merchants, and in every issue of The World there is contained educational matter, instructive service, business news and technical articles which are worth many times the cost of the paper.

Thousands have been benefited by the business articles which appear in The World, and every talking machine dealer should receive it regularly.

The only way to do that is to pay for it, and the cost is trifling—a little over eight cents a month, and for that small sum The World, with all its mine of information, is at your service.

If you do not receive the paper regularly, just put your dollar in an envelope and address it to the office of the publication, and you will say that it is the best investment that you have ever made.

Do not delay but send on your dollar now.

Recollect that your competitor is getting The World—getting it regularly, and in it he is securing some valuable pointers—information which places you at a disadvantage if you do not read the paper.

Do not overlook such a valuable contributing factor to your business success.

EDWARD LYMAN BILL
PUBLISHER

373 Fourth Avenue, New York City



Wherever there is a person who likes music, there is a market for Edison Phonographs.

This line is so complete that it best meets the requirements of all tastes and all incomes, of those who are themselves musicians and of those who can neither play nor sing but who love good music.

Just as the field of good music on the Edison is unlimited, so the audience to which it appeals is anything that you want to make it.

Thomas A Edison

INCORPORATED

59 Lakeside Ave., ORANGE, N. J.

The TALKING MACHINE WORLD

AND
NOVELTY
NEWS

Published Each Month by Edward Lyman Bill at 373 Fourth Avenue, New York, February 15, 1914



A Corner of the Music Room
in the White House



Photo copyright by Waldon Fawcett, Washington, D. C.
Permission for reproduction granted to Victor Talking Machine Co., Camden, N. J.

Leading Jobbers of Talking Machines in America

Landay
BROS INC.

VICTOR JOBBERS Exclusively
What you want always in stock
400 Fifth Avenue
27 W. 34th Street
563 Fifth Avenue
153 W. 42d Street } **New York**

1856 **WURLITZER** 1914

VICTOR
DISTRIBUTERS
VICTORS EXCLUSIVELY

We make a specialty of getting the order out on time—every time.

The Rudolph Wurlitzer Co.
CINCINNATI and CHICAGO

Two points of supply; order from the nearer.

CHASE & WEST DES MOINES IOWA

Machines **Victor** Everything
Records in stock all
Cabinets the time.

WHOLESALE TO IOWA TRADE

Send us your name and address and we will mail you postpaid complete illustrated catalogues, giving detailed information concerning all Victor products. Showing the various styles of Victor Machines, list of all Victor Records, the entire line of Victor Cabinets, Repair Parts and all Accessories. Dealers, let us help you build a Victor business.

PERRY B. WHITSIT L. M. WELLER

PERRY B. WHITSIT CO.,

213 South High Street, Columbus, Ohio.

Edison Phonographs and Records **JOBBERS** Victor Talking Machines and Records

**OLIVER
DITSON
COMPANY**

BOSTON

Largest VICTOR Talking Machine Distributors East of Chicago.

Creators of "The Fastest Victor Service." Let us tell you more about our service.

W. J. DYER & BRO.

Saint Paul, Minn.

VICTOR & EDISON
Distributors

Quick Service for all points in the Northwest. Machines, Records, Supplies.

**VICTOR DEALERS
TRY US FIRST**

We carry the Largest Stock of VICTROLAS, RECORDS and CABINETS of any Distributor in the South.

THE CORLEY COMPANY, Richmond, Va.



Where Dealers May Secure

COLUMBIA

Product

Ready, Full Stocks, and Prompt Deliveries from Convenient Shipping Centers all over the United States.

Distributors

- Atlanta, Ga., Columbia Graphophone Co., 132 Peachtree St.
- Baltimore, Md., Columbia Graphophone Co., 305-307 North Howard St.
- Birmingham, Ala., Columbia Graphophone Co., 1818 Third Ave.
- Boston, Mass., Columbia Graphophone Co., 174 Tremont St.
- Buffalo, N. Y., Columbia Graphophone Co., 622 Main St.
- Chicago, Ill., Columbia Graphophone Co., 14 N. Michigan Ave.
- Cincinnati, O., Columbia Graphophone Co., 117-119 W. Fourth Ave.
- Cleveland, O., Columbia Graphophone Co., 913 Euclid Ave.
- Dallas, Tex., Southwestern Talking Machine Co., 1403 Main St.
- Denver, Colo., Columbia Stores Co., 505-507 Sixteenth St.
- Detroit, Mich., Columbia Graphophone Co., 114 Broadway.
- El Paso, Tex., Southwestern Talking Machine Co., Stanton and Texas Sts.
- Hartford, Conn., Columbia Graphophone Co., 719 Main St.
- Indianapolis, Ind., Columbia Graphophone Co., 27 N. Pennsylvania St.
- Kansas City, Mo., Columbia Graphophone Co., 1112 Grand Ave.
- Lincoln, Nebr., The Grafonola Company, 1038 O St.
- Livingston, Mont., Scheuber Drug Co.
- Los Angeles, Cal., Columbia Graphophone Co., 420-422 S. Broadway.
- Louisville, Ky., Columbia Graphophone Co., 423 South Fourth St.
- Milwaukee, Wis., Albert G. Kunde, 518 Grand Ave.
- Minneapolis, Minn., Columbia Graphophone Co., 424 Nicollet Ave.
- New Haven, Conn., Columbia Graphophone Co., 25 Church St.
- New Orleans, La., Columbia Graphophone Co., 933 Canal St.
- New York City, Columbia Graphophone Co., 89 Chambers St.; Columbia Graphophone Co., 35-37 W. 23d St.; Columbia Graphophone Co., 39 W. 125th St.
- Philadelphia, Pa., Pennsylvania Talking Mach. Co., 1109 Chestnut St.
- Pittsburgh, Pa., Columbia Graphophone Co., 101 Federal St.
- Portland, Me., Columbia Graphophone Co., 550 Congress St.
- Portland, Ore., Columbia Graphophone Co., 371 Washington St.; Ellers Music House.
- Providence, R. I., Columbia Graphophone Co., 119 Westminster St.
- Rochester, N. Y., The Grafonola Company, 38 South Ave.
- Sacramento, Cal., Kirk, Geary & Co.
- Salt Lake City, Utah, Daynes-Beebe Music Co., 45 Main St.
- San Francisco, Cal., Columbia Graphophone Co., 334 Sutter St.
- Seattle, Wash., Columbia Graphophone Co., 1311 First Ave.; Ellers Music House, 3d and University Sts.
- Spokane, Wash., Columbia Graphophone Co., 818 Sprague Ave.
- Springfield, Mass., Columbia Graphophone Co., 174 Worthington St.
- St. Louis, Mo., Columbia Graphophone Co., 1008 Olive St.
- St. Paul, Minn., Columbia Graphophone Co., 17 East Sixth St.
- Tampa, Fla., Tampa Hardware Co.
- Terre Haute, Ind., 640 Wabash Ave.
- Toledo, O., Columbia Graphophone Co., 229 Superior St.
- Washington, D. C., Columbia Graphophone Co., 1210 G St., N. W.

DEALERS WANTED—Exclusive selling rights given where we are not actively represented.

Write for particulars to the Columbia Graphophone Co., Wholesale Department, Woolworth Building, New York.

Headquarters for Canada:

Columbia Graphophone Co., 363-5-7 Sorauren Ave. Toronto, Ont.

Every Jobber in this country should be represented in this department. The cost is slight and the advantage is great. Be sure and have your card in the March List.

SANGER BROTHERS
Dallas, Texas

VICTOR
Distributors

"We ship the same day."

W. D. ANDREWS

Syracuse - - Buffalo

All orders are acknowledged the same day received by shipping the goods. Make us prove it. All foreign records in our stock.

Victor - - Edison

Southern Victor Dealers

Largest Stock VICTROLAS and RECORDS. Prompt Shipment and Low Freight Rates.

WALTER D. MOSES & CO.
Oldest Music House in Virginia or North Carolina.
RICHMOND, VA.

Edison Phonograph Distributors
for the SOUTHWEST

All Foreign Records in Stock

Houston Phonograph Co., HOUSTON, TEXAS

NEW ENGLAND
JOBING HEADQUARTERS
EDISON AND VICTOR

Machines, Records and Supplies.

THE EASTERN TALKING MACHINE CO.
177 Tremont Street BOSTON, MASS.

PACIFIC COAST DISTRIBUTORS OF

Victor Talking Machines and RECORDS

STEINWAY PIANOS—LYON & HEALY

"OWN MAKE" BAND INSTRUMENTS

Sherman, Clay & Co. San Francisco Portland Oakland Los Angeles

Talking Machine Dealers

Who are desirous of adding new features to their line should consult

The Music Trade Review

This is the oldest music trade publication in this country, having appeared without interruption since July, 1879.

It is published every Saturday, and contains a thorough and exhaustive resume of all departments of the music trade industry.

Its editions vary from 60 to 150 pages.

It is conceded to be the most influential paper representing the music trade, and if you are interested in the topics with which it deals, do not fail to receive this paper regularly.

Ask for a sample copy.

Regular subscription price is \$2 per year.

EDWARD LYMAN BILL

EDITOR AND PROPRIETOR

373 Fourth Ave., New York

The Talking Machine World

Vol. 10. No. 2.

New York, February 15, 1914.

Price Ten Cents

DANCE RECORDS SCARCE IN ST. LOUIS.

Heavy Demand for Such Records, with Dealers Unable to Get Sufficient Stock—Jobbers Between Two Fires—Remarks of Mr. Rauth.

(Special to The Talking Machine World.)

ST. LOUIS, Mo., February 7.—The dance is the thing in the talking machine business in this section at present. Dance record sales are exceeding the factory speed limit, or at least they are trying to, but unfortunately for the dealers, they cannot sell more records than the factories will turn out. With this rush for dance records comes an accompanying demand for machines to play them. Perhaps this is the explanation of the excellent business that is being reported for January, but the movement of machines is too heavy to ascribe it to the dance demand alone; part of the demand must be ascribed to the general gain in business.

But seriously, there probably is not a dealer in this section that has had all of the dance records he wants. Some of them have revived some old records that will meet the demand, and have cleared out these when the ones that are called for are not at hand. This shortage is peculiar in that it affects all makes as far as this territory is concerned. A saving grace of the situation is that the new dances are so much alike that if the dance called for cannot be had, some other will do.

The wonderful jump of the talking machine business in December, and its maintained pace through January, has set a good many dealers in this musical thinking, who had not given really serious attention to this line before.

A letter received by the Koerber-Brenner Music Co., the well-known Victor distributors, a few days ago, illustrates the situation. E. C. Rauth, vice-president of the company, was on a trip through Kentucky and to other Southern points and varied his route to a town not heretofore visited. He got a very nice record order and a few days after his return home received a letter from the dealer thanking him for the prompt shipment, and concluding: "I gave you the records I could not buy of the two jobbing houses I have formerly patronized, and you filled it 50 per cent. Please accept my thanks." The fact that a dealer is willing to thank a jobber for a 50 per cent. filled order shows what the situation is in this section.

Concerning this trip Mr. Rauth says that the business accumulated for immediate shipment was surprising. "It all goes to show that the dealers are not overstocked after the holidays, and that they are appreciating the possibilities of this constantly growing business."

MAYERS BUYS ROONEY STORE.

Ninth Avenue Dealer Will Conduct This Establishment as a Branch Store.

The stock, assets and good-will of the talking machine store of John J. Rooney, 1983 Broadway, New York, recently adjudged bankrupt, was sold at a private sale February 2 by J. N. Blackman, receiver. The purchaser, who was the highest bidder at the sale, sold the store in turn to A. H. Mayers, the well-known Victor and Edison dealer at 790 Ninth avenue, New York, who will conduct the store at 1983 Broadway as a branch establishment.

LOWER DUTY ON RECORDING WAX.

The Board of General Appraisers this week upheld the claim of A. H. Ringk & Co., importers and customs house brokers, relative to their request for lower duty on importations of wax specially prepared for use in making records.

Collector Malone classified the article as a manufacture of wax not specially provided for, under Paragraph 462 of the old act, and exacted duty at 25 per cent. ad valorem. The importers said the wax was an unenumerated manufactured article, dutiable at 20 per cent. under paragraph 489.

GREAT BUSINESS INCREASE

In Talking Machine Department of J. W. Jenkins' Sons Co., Kansas City, Necessitates Erection of New Demonstrating Rooms.

(Special to The Talking Machine World.)

KANSAS CITY, Mo., February 6.—To such proportions has grown the business of the talking machine department of the J. W. Jenkins' Sons Music Co., of this city, under the management of Burton J. Pierce, that it has been found necessary to remodel the company's store for the purpose of making room for four additional demonstration rooms. The new rooms, built of mahogany and plate glass and perfectly sound-proof, will be located on the ground floor, where there are already ten rooms, and when the new equipment is installed the company will have in all twenty-one rooms devoted exclusively to the demonstration of talking machines.

Michael Bard, who has been connected with the Jenkins house for the past five years as salesman, making some records in that line, has resigned for the purpose of entering another line of business.

NEW EDISON JOBBER IN SEATTLE.

Pacific Phonograph Co. Incorporated in That City with A. R. Pommer at Its Head.

(Special to The Talking Machine World.)

SAN FRANCISCO, CAL., February 6.—The Pacific Phonograph Co., N. W., has been organized to engage in the jobbing business of Edison products, with headquarters in Seattle, Wash. A. R. Pommer, proprietor of the Pacific Phonograph Co. in this city, is head of the concern, and C. O. Baker is secretary and manager. Mr. Baker is new in the talking machine business and also new in Seattle, coming from Colorado, but he is taking hold of the enterprise in a creditable manner and is getting things started in very good shape, with the assistance of J. E. McCracken, the well-known traveler for the local company, who is up there at present for the purpose of directing matters where experience is needed. Mr. Schwab will act as traveling representative of the Northern house. In the future the entire Northwest will be covered from Seattle, instead of from this office, which will enable the Pacific interests to give better service in that section. The Seattle warerooms are at 310 Maritime building, where spacious quarters have been secured in a desirable wholesale section.

TALKER MUSIC FOR WAR DANCES.

Indians at Annual Meeting in Lincoln, Neb., Hear Their Native Music Reproduced.

(Special to The Talking Machine World.)

LINCOLN, NEB., February 5.—The monotonous, rhythmic thump of the Indian tom-tom with the quavering falsetto of the squaws as they danced the "Omaha" and "Sun" dances in circles of whirling war-bedecked savages were made realistic recently for 200 gray haired men and women who met at the Temple Theater in the annual meeting of the Territorial Pioneers' Association. The music was played on a talking machine. These wax impressions were secured by Prof. M. R. Gilmore, of the university faculty, who is arranging for their preservation in the university archives.

BARKER BROS. NEW QUARTERS.

(Special to The Talking Machine World.)

LOS ANGELES, CAL., February 5.—Arrangements have been completed by Barker Bros. for new quarters for the talking machine department, which will give this department a much more prominent place in the business. A number of new demonstration rooms are being installed on the main center floor, where attractive and splendidly equipped quarters are being fitted up. J. H. Booth, manager of the department, expects to leave for the East shortly.

NEW STORE IN MILWAUKEE.

The Milwaukee Phonograph Co. to Open a Large Retail Store at 213-215 Second Street About March 1—Will Feature the Edison Line—Place to Be Attractively Fitted Up.

(Special to The Talking Machine World.)

MILWAUKEE, WIS., February 9.—The Milwaukee Phonograph Co., jobbers in Wisconsin for the Edison line, has completed all arrangements for opening a large retail Edison store at 213-215 Second street about March 1, or soon after that date. William A. Schmidt, manager of the company, has had the plan in mind for several months, but has been waiting until he could secure the proper location. There are undoubtedly wonderful possibilities for a large downtown retail Edison store in Milwaukee, and Mr. Schmidt believes that the exclusive location which he has secured will insure a big business from the high-class trade. Two floors of the Second street building will be occupied and there will be more than 15,000 square feet of floor space available. Most of the first floor will be occupied by the new retail department, while the remainder of the space will be taken up by the wholesale department of the company, which will be moved from its present quarters at 347-349 Broadway. Offices of the wholesale department will occupy the first floor, while the second floor will be given up to stock rooms and demonstration parlors for dealers. Handsome parlors for the retail trade will be opened on the first floor. Several thousand dollars will be spent, according to Mr. Schmidt, in fitting up a complete and attractive Edison store which will surprise the people of Milwaukee. Mr. Schmidt has not selected, as yet, a manager for the new retail store, although he says that he has several men in mind for the place.

DRAFTING HYPOTHECATION BILL.

National Association of Credit Men Perfecting Bill Which Will Protect Manufacturers from Customers Who Secretly Hypothecate Their Accounts Receivable—Interesting Details.

The Legislative Committee of the National Association of Credit Men is still busy on the bill it is drafting to protect manufacturers and jobbers from customers who secretly hypothecate their accounts receivable. According to W. W. Orr, assistant secretary of the association, the committee is trying to draft a bill which will be protective to the creditors without being oppressive to the mercantile bankers and financial companies. It has been suggested to the committee, Mr. Orr said this week, that it make provision for amending the State law applying to chattel mortgages so that it will provide for compulsory filing with the County Clerk of records of accounts that are sold to financial companies. The main idea of the bill is publicity, and this is what many of the newer companies do not want. The amendment to the chattel mortgage law is being worked successfully in the Province of Saskatchewan, Canada, it is said this week, that it make provision for amending such provision is now in effect.

BUYS FULL SET OF OPERA RECORDS.

Unusual Sale of Victor Records Made Recently by Krausgill Piano Co., Louisville, Ky.

A record sale of particularly interesting character was made recently in Louisville, Ky., when the Krausgill Piano Co., of that city, sold to one man, R. T. Durrett, a complete set of Victor opera records for a present to a friend. The Krausgill Co. believes that the sale sets a new record, for although it is a frequent occurrence to sell all the records of one or even several operas, it is believed to be the first case where a single purchaser has taken a complete set of records of all the operas in the Victor catalog at one time.

SPECIAL CENSUS OF TALKING MACHINE INDUSTRY.

W. M. Steuart, Chief of Division of Manufacturers of the U. S. Census, Seeks Co-operation of and Suggestions from Manufacturers and Others Connected with the Talking Machine Trade to Insure Accuracy in Compiling Statistics Regarding the Industry.

(Special to The Talking Machine World.)

WASHINGTON, D. C., February 7.—Talking machine manufacturers as well as jobbers and dealers are invited to volunteer suggestions as to how the coming special census of the manufacture of musical instruments, which will include talking machines, may be made more complete and of greater value in the trade. The World is asked to carry this message to all the interests in the industry by W. M. Steuart, Chief of the Division of Manufactures of the United States Census.

The purpose of the special census of 1914 in the musical instrument field will be, like its predecessors, to show the absolute and relative magnitude of the different branches of the industry; the growth and decline of manufacture in the various lines; the size and character of the establishments, etc. Obviously, such information is of value chiefly to the persons who are engaged one way or another in the musical instrument business, and it is with the object of giving the trade just the class of information that would be of use to the Census Bureau officials who have asked The World to circulate a broadcast invitation.

There are a number of topics on which the officials want specific information, such as the matter of costs of material and other changes that have occurred during recent years in the talking machine as well as other lines of business in the music trade field.

The officials are in a quandary as to whether or not they should not henceforth in gathering statistics as to the manufacture of sound-producing instruments make separate tabulations of the horn machines and the hornless or cabinet machines that have latterly attained such vogue. They are waiting to hear from the trade on this score.

Again they would appreciate hints as to whether the trade would prefer to have separate statistics upon the manufacture of single-sided and double-sided records instead of having all disc records lumped as heretofore. In the last census, too, there was no attempt to separate, in tabulation, the cylinder records and blanks produced for entertainment purposes from those designed for office dictation work. The officials would like to have somebody "on the inside" tell them whether it would be well to specialize further in this direction.

Anxious to Meet Manufacturers' Wishes.

In all instances the Government officials are

anxious to as nearly meet the wishes of manufacturers as is possible. For instance, in speaking of possible changes in the scope of talking machine statistics, the expert in charge of this part of the work, said to The World: "Whereas we are anxious to compile all the statistics that would be of value, we realize that there are so comparatively few manufacturing firms engaged in this industry that we must exercise the greatest caution not to make public information that, if closely scrutinized, might disclose some of the business secrets of firms in this field."

Members of the trade may in some instances be a trifle mystified as to the early activity in preparation for the coming special census in view of the fact that this census is to cover the calendar year 1914, and consequently the actual compilation of the figures cannot commence until early in 1915. The explanation of the quest for advice a year in advance is found in the fact that the officials are now preparing the schedules—the lists of questions which will be sent to every manufacturer of musical instruments in the United States.

Revising List of Manufacturers.

If any change is to be made in the character of the information gathered—that is, if any new questions are to be put to manufacturers as to the volume of their business—it will be necessary to outline it on the printed blanks which will be mailed to manufacturers during the close of the present year. Meanwhile, as another preparatory activity the Census Bureau is revising its confidential list of the musical instrument and talking machine manufacturers of the United States.

One plan that has been formulated tentatively by the officials of the Bureau of Manufactures contemplates that the musical instrument census of 1914 shall embody a discussion and analytical study of the industry with reference to its trend and development and not a mere array of figures, as is the case with the census the returns of which have just been printed in permanent form. Ten years ago special reports of this kind were made in the case of a number of industries—although I believe that music trade production was not then included—but if men in the trade will urge such special study by an expert there is little doubt that the musical instrument business can have such representation in the project now taking shape.

The Chief of the Division of Manufactures expects to have complete figures regarding the industry on hand at the end of the present year, so that the full results of the census of all branches

of the music trades will be published during the summer or autumn of 1915—an unprecedented record in view of the fact that always heretofore it has required at least three or four years to complete the canvass and publish the data. It is expected that the coming census will show that the manufacture of musical instruments (including talking machines and phonographs) is one of the eight most important industries in the United States, and as such it will merit prompt analysis of the statistics and announcement of the results.

EUREKA PHONOGRAPH CO. CHARGE.

(Special to The Talking Machine World.)

CALUMET, MICH., February 6.—Among the shipments of freight recently received here was 480 pounds of talking machine needles, which were shipped to McLogan & Pierce, dealers in talking machines and other musical goods on Fifth street, Red Jacket.

Manager Logan, of this firm, stated that this is one of the largest shipments of needles ever made to one firm in the State of Michigan, or perhaps in any town in the entire Northwest. The shipment of talking machine needles covers all varieties, including soft tone, loud tone, wooden, fiber, nickel, steel, large and small, in fact every sort of a needle that is made for a talking machine.

The McLogan & Pierce concern covers a large territory, including the iron district, and its increasing business necessitated having a large stock on hand to meet supplies. They have just moved into large and spacious quarters in the old Keckonen Building on Fifth street, where they will have much larger quarters to meet the demands of their business, which is steadily growing despite the strike in the copper country, which territory this firm covers very largely.

KING CANS HIS SPEECHES.

Christian X, of Denmark Talks Into Phonograph for Posterity—Cablegram from Edison.

King Christian X., of Denmark, is the first monarch who has talked into a phonograph for the purpose of preserving his voice for the historic phonographic archives in the Danish Royal Library.

He repeated into the instrument his proclamations and his speech from the balcony of the Analienborg Palace to a great gathering of cheering people when he received the crown after King Frederick's sad death in a Hamburg street.

The following congratulatory cablegram was received from Thomas A. Edison: "I am pleased to learn that the Danish nation should be a pioneer in preserving for posterity the methods and life of their ancestors."

It Requires No Great Stretch of the Imagination to Realize That Eastern Service Must Be Good

CONSIDER: The fact that we have been handling talking machines, records and supplies *exclusively* for nineteen years.

- : That our entire time, energy and attention is devoted to one line.
- : That constant application is given to the betterment of our service.
- : That our stock is large, complete and up-to-date, and our shipping facilities unusual.

THEN YOU HAVE some of the reasons why EASTERN SERVICE is different from the ordinary.

The absolute proof is in the trying. Try it.

EASTERN TALKING MACHINE COMPANY

177 TREMONT STREET, BOSTON, MASS.

EDISON

FOR NINETEEN YEARS TALKING MACHINES EXCLUSIVELY

VICTOR

UNIQUE RECORD ALBUMS

CONTAINING SIX PAGES OF INDEX

For Durability, Artistic Design and Finish, our Albums have no equal. They are made in the most substantial manner by skilled workman, and are first-class in every particular. We sell them at very low prices to meet competition.



DISC RECORD ALBUMS
ARE WHAT EVERY
Talking Machine Owner
MUST NOW HAVE

With the index they make a complete system for filing away all disc Records, and can be added to, Album by Album, as Records accumulate, like books in a library.

OUR SUPERB ALBUMS ARE BEST FOR VICTOR, COLUMBIA AND ALL OTHER TALKING MACHINES

MADE IN TWO SIZES TO FIT ALL 10 AND 12-INCH DISC RECORDS

These Albums contain 17 pockets made of strong fibre paper, each pocket having a hole in the center, as shown in the picture. These pockets are so made that they show very plainly both the single and double face titles on the Records. The Albums are bound in the finest quality of Brown Silk Finish Cloth, with gilt title on front cover. They are also bound in imitation leather. Write for sample and prices of our Albums, which are superior to all others.

Address NATIONAL PUBLISHING CO., 235 South American St., Philadelphia, Pa

A LIVE TALKER DEPARTMENT.

Section of Main Floor of Store of F. G. Smith Piano Co., Washington, D. C., Given Over to Sale of Victor and Columbia Machines.

(Special to The Talking Machine World.)

WASHINGTON, D. C., February 7.—So rapid has been the development of the business of the talking machine department of the F. G. Smith Piano Co., at 1217 F street, this city, that it was recently found advisable to move the department to the main floor of the company's building, where sound-proof and other special equipment was installed to facilitate the proper handling of the trade. The accompanying illustration affords an excellent idea of the general attractiveness of the department.

The F. G. Smith Co. handles both the Victor and Columbia lines of talking machines and records, and features both in an aggressive manner. Complete stocks of both makes of records are always kept on hand. The business in both machines and records during the holidays was in excess of any previous record made by the company, while trade for January was in excess of same month last year.

In addition to the talking machine lines the F. G. Smith Co. also handles the Chickering, Bradbury and other makes of pianos and player-pianos with great success.

A RECIPE FOR "MAKING GOOD."

As a man's knowledge broadens to understand the relations between his own special work and the work of other departments, he tends to become inventive. He will probably see means of improving a method or process, some economy that could be effected, some difficulty in inter-departmental relations that could be smoothed away. Every time he succeeds in securing any such advantage, his interest in his work and his self-confidence

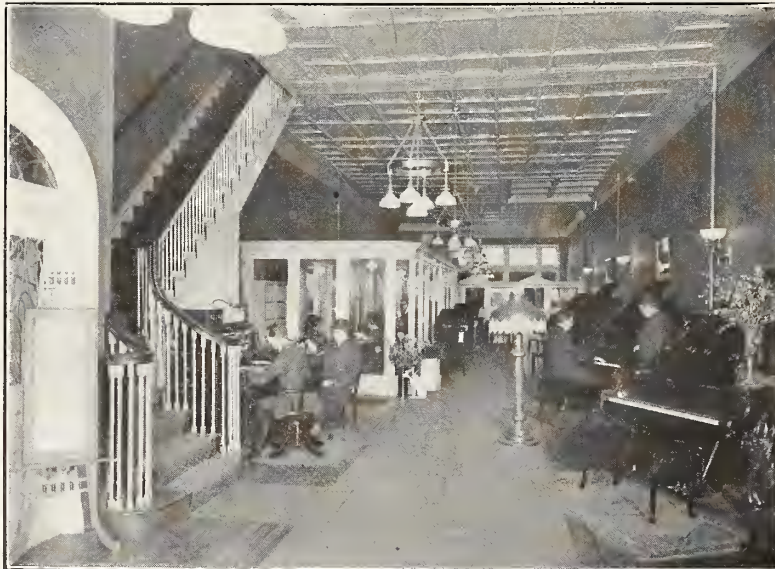

F. G. Smith Piano Co.'s Talking Machine Display Rooms, Washington.

are increased. He grows. As soon as he begins to accept or to gather information beyond the special task entrusted to him, such growth begins in him. And when such growth begins, a man always wants more and more knowledge. He becomes absorbed in a satisfying pursuit. His part in the business will never be monotonous. Both that part and the entire business will be alive with interest.

FEATURING DANCE RECORDS.

Columbia Graphophone Co.'s Store in Boston Makes Capital Out of the Run of "The Sunshine Girl" and Sells Many Records of Argentine Tango from That Play—Miss Sanderson Uses the Grafonola—An Interesting Letter.

(Special to The Talking Machine World.)

BOSTON, MASS., February 7.—The Columbia Graphophone Co., 174 Tremont street, is closing a splendid dance record business, which has been aided considerably by the testimonial given in store by Julia Sanderson, the prominent actress, appearing in the successful play, "The Sunshine Girl." One of the most successful records in the Columbia catalog is the one featuring the Argentine Tango from Miss Sanderson's play, and this dance was rehearsed by Miss Sanderson with the assistance of a Columbia Grafonola.

Miss Sanderson's letter to the Boston store reads as follows: "It may please you to know that the Columbia Grafonola I am using at my hotel and theater is a wonderful help to me and Mr. Mudie in rehearsing before each performance the Argentine Tango. The music as rendered on your instrument is of better tempo than that furnished by the average orchestra. You are to be commended on the splendid tango selections made by the Municipal Band of the Argentine Republic. I should like to see more Bostonians learning this new dance, as it is especially beneficial to their health and figure. Anyone seeing my dance in 'The Sunshine Girl' at the Hollis Theater would know I liked 'The Tango,' but the beautiful grand opera selections and instrumental records made by your company give me an equal amount of pleasure."

As a rule, the man who is always hinting that a raise in salary would be appreciated is not to be looked upon as favorably by his employer as is the man who takes an interest in the business, does his best and depends on merit for a raise.

DANCE MUSIC HAS THE CALL ON THE PACIFIC COAST.

Present National Dancing Craze Has Good Effect on Volume of Record Sales—Wiley B. Allen Co. Business Shows Big Gain—Sherman, Clay & Co. Officials Visiting Branches—Bacigalupi Business Divided—Byron Mauzy Store Remodeled—Other Trade News.

(Special to The Talking Machine World.)

SAN FRANCISCO, CAL., February 6.—Talking machine distributors and dealers here are very well satisfied with the way in which business has kept up since the holidays. In spite of stormy weather, retail sales have been fully up to normal, and the shipping movement has been gratifying. A strong feature of the business the past month has been the steadily increasing demand for dance music; San Francisco seems to have gone dance mad, and no one is profiting more by the craze than the talking machine interests. Everywhere a big demand is reported for dance records, and the trade anticipates an unusually large spring business on account of this particular demand, as it does not seem to interfere with the sale of other records. Naturally an increased demand for machines is expected also.

Heavy Gain in Talker Department.

George R. Hughes, assistant manager of the Wiley B. Allen Co., says the closing of books for the year while revealing that the volume of business in the piano department barely held its own, the talking machine department showed a decided gain, the holiday season being a banner one in that part of the business, both here and in San Francisco and at the branch stores. Jas. J. Black, manager of the talking machine department here, reports a strong demand for the Style XI Victor Victrola, and he says the popularity of the new dances has stimulated the demand for medium priced records to a noticeable extent.

To Visit Sherman, Clay & Co.

Andrew G. McCarthy, treasurer of Sherman, Clay & Co., and manager of their wholesale and retail Victor business, planned to visit the company's interests in the Northwest this month in company with Phil T. Clay and Geo. W. Bates, auditor of the company, when they made their annual trip of inspection, but did not get away with them, so will now make his trip a little later.

Big Demand for Columbia Dance Records.

At the local warerooms of the Columbia Graphophone Co. the year is reported starting off in a very encouraging manner, with a rapidly increasing demand for dance records. F. Anglemier, manager of the wholesale department, says he has already booked a good many orders for numbers appearing on the March list. A new man has been added to the local traveling force in the person of Clifford P. Le Roy, who has been in the office for some time. In future C. J. Moore will devote his attention to the city, and Mr. Le Roy will look after the country. Mr. Moore returned a short time ago from a visit of several weeks to his home in Kansas City, where he spent the holidays. While away he visited the Columbia interests there, in Denver and other cities where he stopped.

George P. Metzger a Visitor.

George P. Metzger, advertising counsel of the Columbia Graphophone Co., spent a few days in San Francisco the past month while on a tour of the country, making an inspection particularly of the retail situation. This was his first visit to California.

Bacigalupi Business Divided.

The talking machine department of Peter Bacigalupi & Son has been separated from the electric piano part of the business, the former having been taken over by Peter Bacigalupi, Jr., who has been in charge for a long time, and Mr. Bacigalupi, Sr., acquiring all interest in the other part of the business. In the talking machine department a jobbing and retail business is conducted in Edison and Victor products.

Byron Mauzy Store Remodeled.

Extensive improvements have been inaugurated at the store of Byron Mauzy on Stockton street, including the enlargement of the ground floor space and the installation of an additional show window, which will afford opportunities for specialized win-

dow displays. Mr. Mauzy maintains a large talking machine department, and has just recently added the Edison disc phonograph, which he will feature in addition to Victor and Columbia lines. Chas. S. Mauzy, son of the proprietor of the store, has been made manager of the talking machine department. He has started to learn the music business from the bottom up, having spent considerable time since he left college at factories in the East, and for several months having been

THREE NEW EDISON ARTISTS

To Make Their Debut in the Edison Blue Amberol Record List for April—The Three Have Long Been Prominent in Church, Oratorio and Concert Work in the United States.

Month after month Thomas A. Edison, Inc. is increasing the roster of artists who are making Blue Amberol records. The April list will contain three newcomers in Beulah Gaylord Young, Grace Couch Embler and Frederick Gordon MacLean. The first named of the three singers has been a mem-



Beulah Gaylord Young. Grace C. Embler.

ber of the Victoria Ladies' Quartet, popular in club, concert and church work, and is also soloist at the Thirty-third Street Collegiate Baptist Church, New York. Her voice is of beautiful quality, perfectly placed and her first number for the Blue Amberol list is "My Chain of Memories," by Mrs. Herbert Ingraham, a pleasing selection.

The second artist, Grace Couch Embler, has

connected with the selling force of his father's store here.

Manager Beck Wants More Space.

P. H. Beck, who operates the talking machine department in the Kohler & Chase store here, is now negotiating for more space. He says the business has gone ahead very gratifyingly in the six months he has been there and that it has already become necessary to provide additional accommodations. He is now located on the mezzanine floor, but hopes to move to one of the upper floors of the building this spring.

A. A. Schell, general manager of the music departments of the Emporium, says business has kept particularly well in the talking machine department since the holidays. Here Columbia products are handled exclusively.

long been popular as a singer in prominent churches in New York and Brooklyn, and has also done oratorio and festival work with Nordica, Bläuvelt and other noted singers. She has also been head



of the large glee club in Brooklyn called "The Emblem Glee." She makes her debut in the Edison Blue Amberol list in Wm. R. Chapman's "Lullaby." The third artist, Frederick Gordon MacLean, is a New Yorker whose musical career started when a boy, having been associated with some of the leading boy choirs up to the time he commenced to study singing. In recent years he has been con-

TO TRAVEL FOR COLUMBIA CO.

(Special to The Talking Machine World.)

KANSAS CITY, Mo., February 6.—One of the recent additions to the local staff of the Columbia Graphophone Co. is H. C. Clowdsley, who will travel through Oklahoma and Kansas as the successor to John Ditzell, who has taken charge of the Columbia department of the Blass department store in Little Rock, Ark.



UNION SOUND BOX

3 THAT SELL ON FIRST SIGHT

At the left is the new UNION Sound Box just 'out, taking Fibre or any make of needle. It is the latest improvement in sound reproduction, and fits all Disc Machines.

UNION TALKING MACHINE SPECIALTIES

The upper right-hand illustration shows the UNION Modifier, a quick selling device, giving Edison, Victor and Columbia owners absolute control over the volume of sound. The lower illustration shows UNION No. 1 for playing Columbia and Victor records on Edison Machines. UNION No. 1 contains the UNION Modifier feature.

Write to-day for descriptive folders and prices on these three easy selling specialties.

All persons selling goods infringing our patents are liable to suit for such infringement.

THE UNION SPECIALTY & PLATING CO.

409 Prospect Ave., Cleveland, Ohio



Gold, Nickel or Oxidized \$5 per dozen net

Gold plated, Nickel or Oxidized \$20 per dozen net

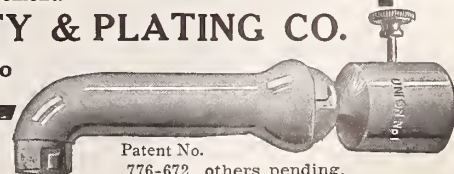

UNION No. 1 Gold Plated, Nickel or Oxidized, \$10 per dozen net

Patent No. 776-672, others pending.

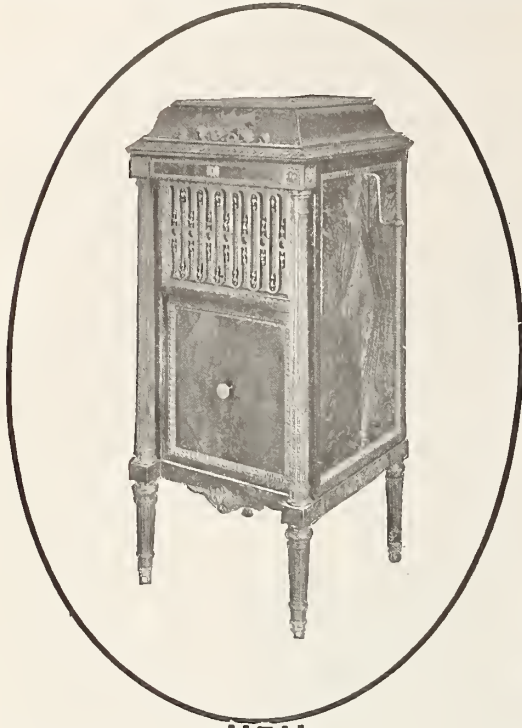
**LOUIS XVI**

Model A450, Circassian
Walnut, \$450.00
Model A400, Mahogany,
\$400.00

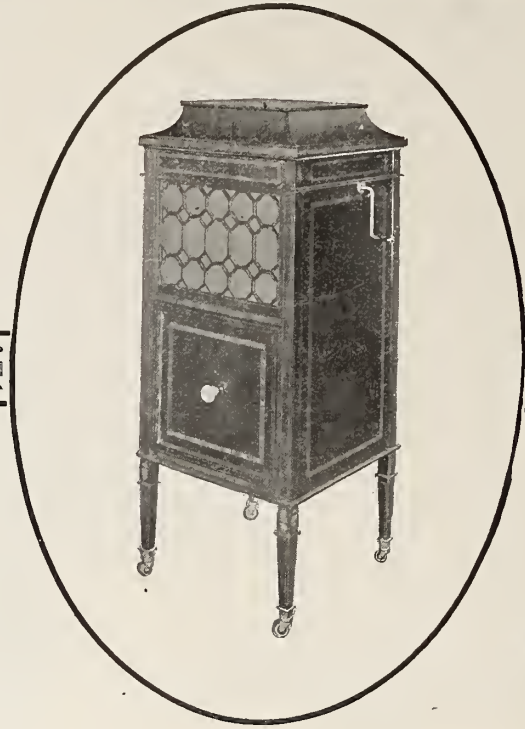
**SHERATON**

Model A275, Ma-
hogany, Inlaid
Plain, \$275.00

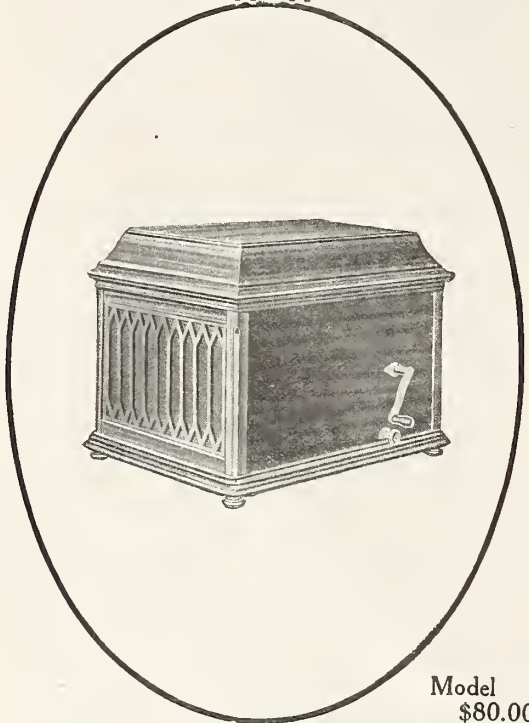

Model A80, Mahogany,
\$80.00

Why the Edison line meets every requirement

Every phonograph purchaser is influenced by two questions: How much can I afford to pay? Do I like the tone?

Every merchant who sells the Edison line has the right answer for both questions. He has a range of models that recognizes the man of modest income as well as the man who can afford to spend more. A purchaser can pay whatever he can afford. That's the answer to the first question.

But it's more important that every phonograph in the line is a true musical instrument—with a voice of mellow, rich quality that makes the Edison line unique on the basis of tone. That's the answer to the second question.

Some people have a preference for cylinder phonographs. Very well, sell them the

Edison Cylinder Phonographs

which have reached a degree of excellence that embodies every noteworthy recent advance in phonographs. In the Edison Laboratories the cylinder types are constantly kept up to the minute.

Thomas A. Edison, Inc.



Model A200, Mahogany
and Oak, \$200.00



Model A300, Cir-
cassian Walnut,
\$300.00



HERATON
Model A290, Mahogany, Inlaid Marquetry, \$290.00

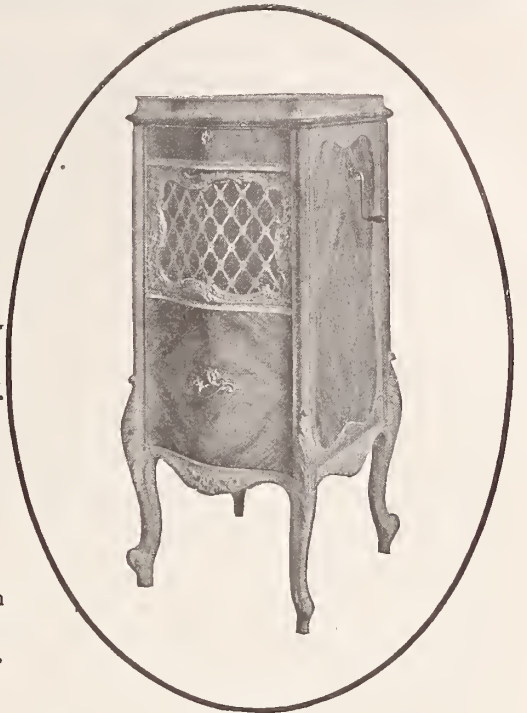

LOUIS XV
Model A425, Circassian Walnut, \$425.00
Model A375, Mahogany, \$375.00

There is the added attraction of novelty about the

Edison Diamond Disc Phonographs

which are now being so extensively advertised. People everywhere are asking to hear them. They want to know about the new diamond reproducer, about the new records—so hard that they are impervious to wear, yet so sensitive that no sound, however minute, fails to be registered.

In a word, the merchant who sells the Edison line has every mechanical and musical argument on his side. He also is able to offer this mechanical and musical excellence at any price that his patrons prefer.

There is a jobber convenient to you. Write us for his name.

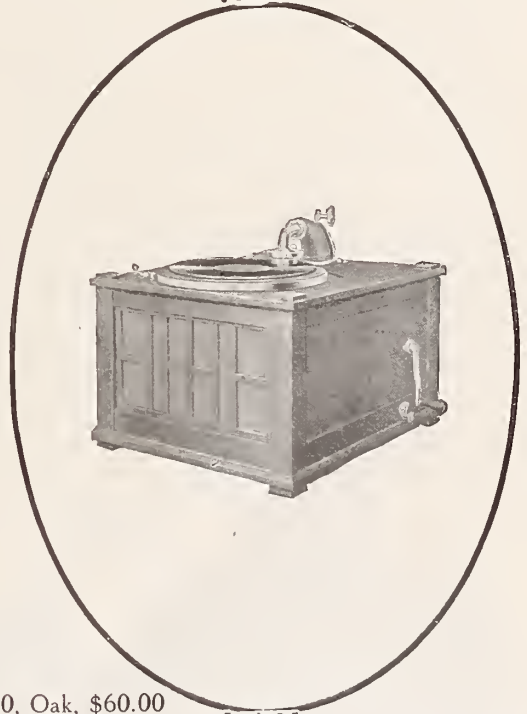

Model B60, Oak, \$60.00

9 Lakeside Ave., Orange, N. J.



Model A250, Mahogany and Oak, \$250.00



Model A150, Mahogany and Oak, \$150.00

HEAVY RECORD TRADE A FEATURE IN CINCINNATI.

Serves to Create an Excellent Post-Holiday Volume of Business—Branch of the Phonograph Co. May Be Made Permanent—What Various Houses Report Regarding Conditions and the Outlook—Big Run on Ysaye Records with Columbia Co.—Other News.

(Special to The Talking Machine World.)

CINCINNATI, O., February 7.—A tremendous volume of talking machine business is now falling to the lot of the Cincinnati dealers. During the past month the demand has been for records, which is only natural, following the sales of machines in December for the holiday season. The feature of the situation to-day is the amount of talking machine gossip that can be heard among the consumers. This, in itself, is a big item and will undoubtedly result in these buyers of the past inducing others to become purchasers.

Some of the friends of John Arnold, while still a young man, but is credited with being the oldest Edison dealer in this market, are much concerned over his physical condition. Arnold has been compelled to seek an absolute rest. He is now at Colorado Springs and is not expected back until shortly before March 1. Mr. Arnold suffered a breakdown during the Christmas rush, but managed to hold on until the latter part of January.

The Cincinnati branch of the Phonograph Co. continues to retail to cash customers and the trade here would not be surprised if the temporary house here was made a permanent one from both a jobbing and retail standpoint. Manager A. O. Peterson Saturday intimated that a vigorous advertising campaign would soon be started in this market. Peterson is preparing to make a personal visit to the factory at Orange, N. J., to see about shipments for his branch. During the past month M. W. Ehrhardt, Franklin; M. N. Billings, Chillicothe, and the Hutchinson Music Co., Portsmouth, O., became dealers for the Phonograph Co.

The Milner Musical Co. Sunday advertised some of the old style machines of all makes, with a collection of records, for \$5.

The talking machine shop at the Lyric Piano Co.

is now on a permanent basis and is attracting much attention. The booths have a snappy appearance and are spacious enough to accommodate a bunch of buyers.

Manager Dittrich, of the talking machine department of the Rudolph Wurlitzer Co., is in a most optimistic frame of mind about 1914. He believes the outlook is even greater than last year. His views follow:

"We have just passed a very busy month. The large number of Victrolas sold in December created a very vast amount of record business, which, when added to the unusually large demand among all Victrola owners, created a condition which is very hard to meet. Our facilities were taxed to the utmost, but we handled the situation with little trouble, and our record stock for a time at least was equal to the occasion. We look forward to the active record months of February and March with great hopes, and with every assurance of being able to cope with the situation.

"The machine situation has been, and is a great problem; every Victrola sold in December is an active salesman, and the machine business this month has been limited only by the amount of stock received from the manufacturer. There is no doubt that 1914 will be far in advance of the previous year, by virtue of the very fact that 1913 was the 'banner' year of the talking machine business."

The Columbia Graphophone Co. took advantage of the visit of violinist Ysaye to feature its product as follows: "Eugene Ysaye, world's supreme master of the violin, makes records exclusively for the Columbia. But if you happen to own a Victor talking machine you can still enjoy these wonderful records, because all Columbia records can be played on Victor talking machines. Likewise, all

Columbia instruments will play Victor records."

There was no hesitancy on the part of Mr. Whelen, Cincinnati manager of the Columbia Graphophone Co., when he said that business has been on the increase instead of on the decrease since the holidays. He said: "Unlike previous years, the opening of 1914 was marked by a wonderful demand for instruments of all prices, from the 'Eclipse' to the Columbia grand, whereas in previous years there has been a great demand for records, but not for machines right after the holiday season. We always expect record sales to double in January, but this year both sales in machines and records have shown a decided increase over the same period of 1913. Nineteen hundred and thirteen has been a phenomenal year, and it only goes to show that the public is realizing more and more the superiority of Columbia goods. Last year the Columbia Co. carried on a tremendous advertising campaign, but this year the advertising department is redoubling its efforts and results are already beginning to show. This 'boom' is not only local, but from reports throughout the territory and from what our traveling man tells us, all the dealers are very sanguine about the prospects for 1914."

Geo. W. Lyle, general manager of the Columbia Graphophone Co., was in Cincinnati for a day and was very enthusiastic about business in general throughout the United States.

January business at Aeolian Hall was most satisfactory, registering a large increase over a year ago. The record and machine departments show large gains, the \$100, \$150 and \$200 models being big sellers.

Manager G. R. Bethel, of the Victor department, has things moving in great shape and has surrounded himself with a most efficient organization. The location of three of the first floor record booths have been changed during the past week so as to give more floor space outside for machine display. The entire rear section of the first floor, formerly used for the general offices of the company, is now being used for Victor record stock.

The Aeolian Co. is a great believer in the efficacy of window display of Victrolas and Victor records. With the splendid location of Aeolian Hall and the large daily crowds of passers-by, the window becomes a very important consideration. Liberal window space is given the Victor line every week. Unquestionably many "drop-ins" result from the Aeolian policy of constant and forcible window display.

DISCUSS 1 AND 2 CENT POSTAGE.

H. T. Griffith, One of the Speakers Before the Publicity Division of the Indianapolis Chamber of Commerce on the Question of Postage for Advertising Letters.

The Publicity Division of the Indianapolis Chamber of Commerce, which was formerly known as the Adscript Club, recently discussed the proper use of one and two-cent postage for advertising letters. A number of prominent advertising men contributed to the discussion, relating their present experiences. Among others were Howard T. Griffith, of the Udell Works, talking machine cabinet manufacturers, who told of his successful use of the red one-cent parcel post stamp for circulars. It will be recalled that the red parcel post stamp is similar in size, color and general appearance to the Panama Exposition stamp. He mailed some circulars in a pink, open-end envelope with a red border, harmonizing in color with the red penny stamp, and found he did better than when he used another penny of postage, the cost considered, for there was practically no difference in the returns.

"TALKER" MANAGER IN ELOPMENT.

(Special to The Talking Machine World.)

SAN FRANCISCO, CAL., February 5.—M. J. Corcoran, of the Oakland Wiley B. Allen talking machine department, was a principal in an elopement on January 27, at which time he and Miss Ruth A. Winter, daughter of a prominent Los Angeles contractor, were married. The romance is said to have had its inception in this New Year's eve festivities, which makes the wooing and wedding all come within a month.



Won't You Have a Lesson in Spanish?

It's so easy to learn by the I. C. S. system—and a knowledge of Spanish is so useful nowadays.

The I. C. S. system of language instruction by means of the phonograph makes easy the mastering of a foreign language, and appeals with compelling power to thousands. The dealer in phonographs who does not carry I. C. S. Language Outfits is neglecting a quick and sure way to increase his business. The new \$35 Language Outfit of the I. C. S. is a marvel. It represents the highest art in the teaching of languages, and embodies a method that has won the warmest praise of thousands qualified to speak authoritatively. The Spanish, French, and German Embassies at Washington, as well as the leading colleges, have cordially indorsed the I. C. S. method of teaching languages.

The I. C. S. Language Outfit consists of an Edison Gem Phonograph made especially for language work; small horn; headband hearing tube; oil can; and 25 Conversational Records teaching pronunciation guaranteed to be absolutely correct, with native intonation and inflection. In addition to these Conversational Records there are pamphlet Instruction Papers teaching the theory of the languages. The new Outfit is at one and the same time the best and cheapest ever offered—the price being only \$35.

If you want to increase your business, write to-day for full particulars.

International Correspondence Schools
Box 918, Scranton, Pa

The advertising Record is still adding names to Columbia Dealers' mailing lists. Its value is measured by the thousands of inquiries it is pulling. Are you getting your share?



(Write for "Music Money," a book "full of meat" for those dealers interested in quick and frequent turnover of capital.)

Columbia Graphophone Company
Woolworth Building, New York

OPPOSE OLDFIELD PATENT MEASURE.

The Merchants' Association Acts Upon the Recommendation of Mr. von Briesen's Committee—Reasons for the Opposition.

Upon the recommendation of the committee on the protection of industrial property the board of directors of the Merchants' Association at its last meeting unanimously voted to oppose the enactment of the Oldfield bill revising the patent laws—H. R. 10153.

The committee, of which Arthur von Briesen is chairman, reached its decision in opposition to the bill after having given the measure extended consideration.

Its reasons, as presented to the board of directors, included the following:

"The proposed law would usurp the functions of the court.

"It deprives the defendant in a patent suit of all rights to prove the invalidity of the patent sued on in any motion by the plaintiff such as is referred to in the bill.

"The amount of five per cent. is arbitrary and

will in many cases be entirely inadequate, and in many cases entirely too high.

"The bill contains no provision for the repayment of the five per cent. in case at final hearing a decree against the plaintiff should be entered.

"The bill appears to deprive the plaintiff of all rights to a preliminary injunction. In many suits a preliminary injunction is the only fair and adequate relief.

"The bill makes possible a multiplicity of suits against one machine embodying different inventions owned by different interests, each of which would then be entitled to a separate five per cent. The bill is generally vague and uncertain."

The association will oppose the passage of the measure in Washington.

BUSINESS GAIN IN INDIANAPOLIS.

Trade During January Shows Big Advance of That for Same Month in 1913—Several Changes Among the Managers—Heavy Demand for Records of Dance Music—Activities of the Various "Talker" Concerns.

(Special to The Talking Machine World.)

INDIANAPOLIS, IND., February 9.—Business is so good in the talking machine lines in Indianapolis that it couldn't be much better. Notwithstanding certain conditions which tended to hamper business in December, a greater amount of business was done in that month than in the same month of the preceding year, and all dealers report that the January business almost equaled the December business.

Several changes have been made at the local branch of the Aeolian Co. at 237 North Pennsylvania street. W. P. Kreisler, formerly manager of the Aeolian Co.'s branch at Dayton, O., has taken charge of the branch here, succeeding J. T. McDermott, who had been manager for some time. Miss Lazarus, who was in charge of the talking machine department of the Aeolian Co. here for over a year, has left the employ of the company. Arthur C. Ruark has taken charge of this department.

Records of dance music are going like hot cakes in Indianapolis. The dealers cannot get enough of them. And with many new customers coming in for dance music the sale of other records has been increased to a noticeable extent. There is considerable opposition to the new dances in Indianapolis, but most everybody is letting the opposition "go hang." And the dance goes on. One newspaper here has employed a dancing expert to teach the tango, hesitation and other dances free of charge. Thus the sale of dance records will increase, talking machine men hope it out.

The talking machine department of the Aeolian Co. had the best January business in years, according to Mr. Ruark. The Columbia Graphophone Co.'s local store at 27 North Pennsylvania street, also reports an excellent January business.

The Stewart Talking Machine Co. is "snowed under" with orders from every nook and corner of the State. The rush started before the holidays and it has not stopped. W. S. Barringer, manager of the Stewart Talking Machine Co., and George E.

Stewart, son of Alexander M. Stewart, owner of the business, have returned from a visit to the Victor factory. Miss M. A. Parsons has been employed by the Stewart Talking Machine Co. as secretary for Mr. Barringer.

The Kipp-Link Phonograph Co. is making strides with the new Edison disc phonograph. This machine is proving to be a favorite among all classes of customers, and the sales records show that it is going into the homes. The Kipp-Link Co. has expended much effort and money to make its headquarters at 345 Massachusetts avenue attractive and comfortable for its patrons. The Kipp-Link Co. has one of the largest talking machine stores in Indianapolis.

OPEN OFFICES IN NEW YORK.

The Triton Phonograph Co. has opened offices at 41 Union Square, New York, where it will handle a line of imported phonographs and talking machine accessories. J. A. Kraus is the manager and A. L. Marks is his associate.

CHAS. BOBZIN DOING DOUBLE DUTY.

Chas. Bobzin, general manager of the Silas E. Pearsall Co., 16 West Forty-sixth street, New York, is working on a double schedule as we go to press, for not only is he fulfilling various duties at the warerooms, but the additional services of juror.

It is natural, therefore, for visitors to find him unusually busy, for all his executive work has to be done in the evenings, but as Mr. Bobzin says, the double work will soon be over and then concentrated effort will be given to seeing that Pearsall dealers get the right service.

The Waltham Watch Co. has appealed to the Supreme Court from decision of the New York Federal Court that its contract fixing resale prices of watches violates the Sherman law.

"Standard" Fiber Needle Cutter

Built Like a Watch
Artistic, Clever, Compact
Toggle Joint, Powerful
It Does Not Sheer
It Cuts
Retains Chips

NOW IN THE HANDS
OF YOUR JOBBER

Standard Gramophone
Appliance Co.
173 Lafayette St., New York

SEND FOR SAMPLES

De Luxe Model
Each in a box and every dozen in a display carton.
Retail for 50c each

"DUSTOFF" RECORD CLEANERS
Add life to records. Keep the tone pure and clear. Get into the minute sound grooves of the record and thoroughly remove all accumulated dust and dirt.
CLEAN ALL MAKES OF RECORDS
Jobbers everywhere and Columbia distributors can supply you. In Canada through Berliner Gram-o-phon Co.
SAMPLES Sent postpaid, on approval, if you write on your business stationery giving jobber's name.
Regular Model
Every dozen in a counter display carton.
Retail for 15c. each.

MINUTE SHINE CO.
179 Canal Street Providence, R. I.

The **TALKING**
For the makers & sellers of talking machines
MACHINE
WORLD

EDWARD LYMAN BILL, - - - Editor and Proprietor.

J. B. SPILLANE, Managing Editor.

Trade Representatives: GLAD. HENDERSON, C. CHACE, L. E. BOWERS, B. BRITAIN WILSON, A. J. NICKLIN, AUGUST J. TIMPE, L. M. ROBINSON.

Boston: JOHN H. WILSON, 324 Washington Street.
Chicago Office: E. P. VAN HARLINGEN, Consumers' Building, 220 South State Street.
 HENRY S. KINGWILL, Associate.

Philadelphia: R. W. KAUFFMAN.
San Francisco: S. H. GRAY, 88 First St.
St. Louis: CLYDE JENNINGS.
London, Eng., Office: 2 Gresham Buildings, Basinghall St. W. LIONEL STURDY, Manager.
Representatives for Germany and Austria: VERLAG NEC SINI, Berlin C. 19, Ross-Strasse 6, Germany. GEO. ROTHGIESSER, Director.

Published the 15th of every month at 373 Fourth Ave., New York.

SUBSCRIPTION (including postage), United States, Mexico, \$1.00 per Year; Canada, \$1.25; all other countries, \$1.75.

ADVERTISEMENTS: \$3.00 per inch, single column, per insertion. On quarterly or yearly contracts a special discount is allowed. Advertising pages, \$100.00.

REMITTANCES: should be made payable to Edward Lyman Bill by check or Post Office Money Order.

NOTICE TO ADVERTISERS.—Advertising copy should reach this office by the first of each month. By following this rule clients will greatly facilitate work at the publication headquarters.

Long Distance Telephones—Numbers 5982-5983 Madison Sq.
Cable Address: "Elbill," New York.

NEW YORK, FEBRUARY 15, 1914

TO read some of the extraordinary advertising announcements put forth by some of the great mercantile emporiums, one would naturally think that the public would not be interested in advertised goods save they were offered at cut prices.

Perhaps we have been fed on this sort of pabulum so long that the buying system demands it! And why in the world the talking machine business should be conducted along the lines of a tiny little cash down and deferred payments extending over a long period we can hardly understand, more particularly when there are not enough machines to go around to-day.

We have very recently received communications from some leading jobbers in which they have expressed great regret that they are unable to secure stock. Now, with such conditions, should not talking machines be exploited on the cleanest kind of a basis without going to the extreme limit of time payments?

The editorial on bargain baiting advertising in last month's World, if we may be permitted to judge by criticisms which reach this office, has set the trade tongues wagging and the sympathy of our readers is entirely with the sentiments expressed in the editorial.

WHEN great mercantile emporiums in the larger cities offer talking machines and records for a month for \$10, and money back if you are not satisfied, they are putting up a kind of competition which is bound to be felt by every small talking machine man throughout the country, because the papers containing notices of such announcements reach the lesser towns and customers naturally ask the local talking machine man why he cannot do as well as the men in the larger cities, particularly as the product is price-safeguarded in every way.

If one has plenty of capital, leases of talking machines and pianos are a very nice investment indeed, but if capital is limited one is apt to tie up all available funds in a very short time, and if the small dealer sells on such ridiculous terms, the results are that his capital is entirely tied up in a very short period, and he will have no cash with which to meet his current obligations.

It takes a long time on the deferred payment plan to get enough machines out so that the intake produces cash sufficient to take care of running expenses.

Piano merchants have found this out—many of them to their sorrow, and in the collapse of the Henry Siegel stores it was shown that there was more than a half million of the assets of the Simpson-Crawford Co. in piano and furniture leases. Inasmuch as they run over three years' time it will be quite a while before this works out advantageously to the creditors.

IT seems to us that it is the poorest kind of advertising to emphasize time business in the talking machine trade, particularly when it is comparatively easy to get the cash. Cultivate the cash plan.

Cash payments count. Time payments are good if the machines are disposed of to reliable parties, but there is always an expense, and a certain percentage of delinquents which total quite a figure at the end of the year.

The talking machine trade should be the cleanest in the world and the most up-to-date, because it is price-regulated and is controlled by progressive, active forces, and yet notwithstanding that some of the concerns in their mad haste to do business will rush in and offer all kinds of allurements to dispose of goods simply to get them out—bulk business—when it would be just as easy, and perhaps a mighty sight easier, to get in a solid volume of cash, and cash is what counts in the talking machine trade, as well as in any other.

A good many of these houses are deliberately turning away cash business from their doors by their unbusinesslike methods.

What is the object of a man paying cash for a talking machine when he can get one for a trifle per month and no interest charge? What is the advantage—why cash, when time works much easier?

THERE are so many things to talk about in the exploitation of such a product that it seems as if terms should be the last thing, particularly when the hungry ones are clamoring for stock to-day.

Then people who have money—plenty of it—oftentimes decide that they will buy machines on the deferred payment plan when the facts are held out to them that there is no object in paying cash.

In the piano line it is a fact that the houses in New York, who have been offering ridiculous terms, have found that some well-known and wealthy people have taken advantage of these offerings—people who would undoubtedly pay cash, but when they have trifling payments, scattered over a term of years they figure why pay cash when cash is worth nothing!

Too easy payments, too little cash, are not good business points to emphasize.

THE training of salesmen is very essential, and Benjamin Switky, the well-known Victor distributor in New York, has made some very valuable suggestions along these lines which he has related to The World for the benefit of readers. Mr. Switky says: "I have heard men say that sales, like poets, are born, not made. But for the benefit of the many who cannot show a birth certificate testifying to their salesmanship, I want to say that I do not believe seriously in the foregoing statement. Every man of average intellect, pleasant personality, with an earnest desire to succeed and a willingness to learn, has within him the material necessary for the making of a salesman."

Now, that is a good, clean-cut expression from a practical business man.

There is no question, but that the training of salesmen is of vital importance to every employer in this country, and if, as The World as suggested at various times, it were a fixed policy with the houses employing a number of men, to get the members of the selling staff together and form schools of salesmanship, they would find the results obtained extremely valuable.

It is absurd to drift along in an indifferent manner, expecting the men to absorb knowledge from various sources when there is proper training talent right within easy reach who could be utilized in moulding so that they would become better money-makers for the house and increase their own salaries in a like proportion, because the average business man is fair, at least, we believe so. We are inclined to think that men are perfectly willing to pay salesmen what they are worth—to raise their salaries according to their increased earning capacity, and there is no other logical way in which salaries may be adjusted equitably, because it is impossible to fix a salary status, where the drone is on the same plane as the ambitiously active man. Surely there must be some incentive for the active, energetic, alert young salesman. His efficiency must count in his salary check even though the drone may be dreaming away his time at the warerooms wondering why he is not better appreciated.

Such men cannot draw the same salary and it is not right

that they should. One is earning profits for the company with which he is employed and the other is not. Now, they cannot be placed on an equal basis, and everything which will stimulate interest in work and which will teach salesmen so that they get out of the drone class and can present their arguments more intelligently should be encouraged.

Every salesman should know something about the technical or practical side of talking machines. At least he should have a fair knowledge of its mechanism. Then it is easy to absorb a knowledge of some of the operas. The development is along easy and pleasing lines—lines which are broadly educational because they will impart a great deal of interesting knowledge to the men who desire information which will be of real value to them.

Get out of the drifting habit—but if you must drift—drift with a purpose.

ALL America is dancing these days. The terpsichorean bug, or germ is in the air inoculating everyone with a desire to tango, to one-step, to maxixe, or indulge in some other of those wonderful contortional efforts which are to be witnessed in hotels, tea rooms, cabarets, theatres—in fact, wherever one turns in New York or other large cities throughout the country.

It goes without saying that one cannot dance without music, and here is where the talking machine is playing an important part. The demand for records for dancing purposes has far exceeded the supply during the past month, and this demand is certain to grow, judging from the growth in popularity of the modern dances.

Some remarkable figures are given by talking machine jobbers as to the output of records for dancing purposes—figures that seem staggering when the enormous numbers of records sold within a recent date is considered.

This demand for records, of course, has increased the call for talking machines, for one is useless without the other. As a result the past month has shown a good increase of business with the majority of talking machine houses throughout the country.

Nowadays the talking machine is indispensable not only for the dances, but for those who desire to hear their operatic favorites in the home, and there can be no question but that the growing attendance at the opera houses in New York, Boston, Philadelphia, Chicago, and other cities, is due to the increased appreciation of operatic music through the use of the talking machine in the home.

As we have said in these columns, time and time again, no one factor is contributing more to the uplift of music in America and its proper appreciation than the talking machine. The critics who sneer at this are evidently not in touch with the conditions or facts.

Like the player-piano the talking machine is fulfilling a great mission. Purchasers may start with rag time, or popular pieces, but they gravitate in time toward a better type of music—to appreciate the better class of songs from the leading operas sung by notable singers, and in due course they want to hear the operas and the singers in person.

This is an evolutionary process that takes place in the majority of homes, and it only needs an investigation by anybody concerned to find hundreds of thousands of instances such as this.

It is entirely in the hands of the talking machine dealers to augment the work of the manufacturers in placing the talking machine in a right light before purchasers everywhere—to treat of it from the elevating—educational—artistic viewpoints, so that its constituency of admirers may be broadened, and those who are still “outside the breastworks” in the matter of knowledge of talking machine progress, may be enlightened and interested.

THE National Association of Credit Men has been bringing to the attention of members the growing practice of secretly selling or pledging accounts. It has been pointed out that new companies are constantly springing up and older ones increasing their capital and constantly bringing pressure to bear on business men for the privilege of advancing cash on their open accounts.

It has been found that the system is proving productive of fraud, not only upon creditors who hypothecate their accounts, but upon the finance companies, for in some recent failures it was disclosed that all accounts receivable had been disposed of through hypothecation. Fraud was even practiced on the finance companies by the duplication of leases under the instalment plan by bogus shipments and other methods.

The question put to the association was, whether the pledge or sale of accounts receivable should not be a matter of public record just as is a chattel mortgage.

It is pointed out that legislation must not narrow the channels of money supply, but some method should be found of protecting creditors against the frauds which are being practiced through the hypothecation or sale of accounts receivable.

Members have been writing the association letters which encourage the exertion of special efforts along this line, and the secretary of the Canadian Credit Men's Association at Winnipeg writes that there has just been put upon the statute books of Saskatchewan a law compelling the registration of the assignment of receivables in the same manner as chattel mortgages, and mercantile agencies are publishing this information just as they do information relating to chattel mortgages. The idea is said to be working out so satisfactorily that the Canadian association intends to approach the legislatures of other provinces for like legislation.

Commenting on this, the editor of The Bulletin, published by the National Association of Credit Men, says that he has no doubt that an attempt to secure corrective legislation in the various States would be met with vigorous opposition, but believes the movement is so important to the protection of commercial credits, that legislatures could be made to see that public interest demands action at an early date.

THE fact that the human race is always dissatisfied has been its salvation, and the same thing applies to that part of the race engaged in the up-to-date business. Everlasting improvement is what we are after, and no sooner has one goal been reached than a longer vision and a wiser head spies out another to be won.

Thus the wide-awake inventor, manufacturer, jobber or retailer is never satisfied with things as they are—improvement is the cry all the time.



“DOLLAR” MOTORS

LATEST SENSATION—DETACHABLE SPRING CAGE

ARE UNQUESTIONABLY
THE BEST AND CHEAPEST

Without any dismantling of the motor, a NEW SPRING may be inserted within a few seconds.

Many patents both at home and in every civilized country applied for.

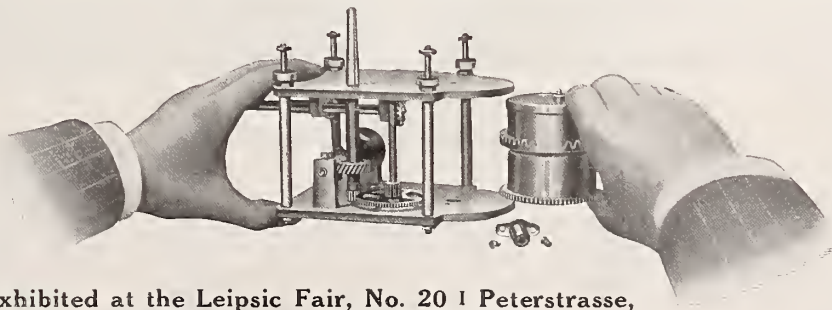

Exhibited at the Leipsic Fair, No. 20 1 Peterstrasse,
Hotel de Russie, Zimmer No. 6.

Our Export Catalogue in four languages, covering 30 styles of motors adapted for Talking Machines, sent free of charge, postage prepaid, for the asking.

Advantages of our Motors:
Noiseless movement
Supreme accuracy
Highest grade of materials
Greatest money value

GEBRÜDER STEIDINGER, Fabrik für St. Georgen (Schwarzwald), Deutschland
Feinmechanik

Cable Address: Gebrüder Steidinger Sanctgeorgenschwarzwald.

Better Value than Other Albums by Reason of Superior Quality

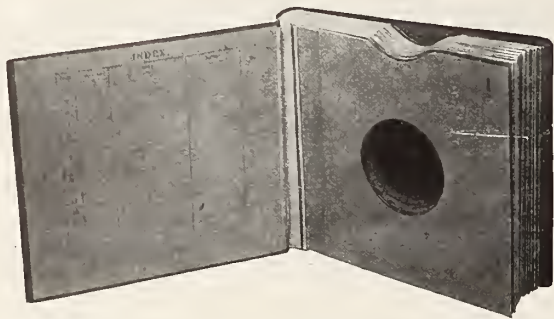

Our Albums are bound **correctly** by expert hands. **Envelope pockets** are constructed of very tough **Dark Green Fibre** paper. Albums are bound in best **Mahogany Imitation** leather, gilt stamping on face and leather or gold-plated ring pulls as desired. Made for 10 and 12 inch discs. Write for sample and prices, which will convince you, as they have all our other customers, of the superior quality and value of our albums.



These albums are constructed with a view to **Strength**, so that they will really hold the **full** complement of discs, and give excellent service.

NEW YORK POST CARD ALBUM MFG. CO., 23-25 Lispenard Street, New York

LOSSES THROUGH SENDING GOODS OUT ON APPROVAL

A Big Factor in the Business of the House Adopting That Policy, Says Manager Ligon, of the Famous & Barr Department, St. Louis—Has Taken a Firm Stand Against the Practice from Straight Business Reasons—Handling the Edison Disc Line.

(Special to The Talking Machine World.)

St. Louis, Mo., February 7.—Manager Ligon, of the Famous-Barr talking machine department, was greatly pleased with the January business, announcing that his sales for the month would be the largest total in the department's existence except that for December. Another pleasing feature was the recent addition of the Edison disc machines to his line. Until his three new sound-proof booths are completed he will show only a sample line of the Edison machines, preferring to let his primary order that is coming from the factory be held back until he is ready to make a real display. He has sold some of the Edisons from the samples and is pleased to note how his customers accept them. Heretofore the department has handled only the Victor line.

Mr. Ligon has some very definite ideas about his department and is being allowed full sway in carrying them out. This department was his first experience in talking machines in this city. He says:

"In my talking machine experience in the South I saw plainly that repossess and returns of goods let out of the store on approval cut into the profits heavily and I resolved then that when I became the head of a department this would be reduced to a minimum. I have seen a department doing less business than we are here have at the end of a year a great stack of damaged records to be charged off the profit account and a dozen of more or less badly used machines on hand because they were permitted to go out on approval.

"I have firmly refused to permit any merchandise to go out of this store until it is sold. The only exchange I offer is where the merchandise does not come up to the standard we set for it. Then the purchaser can have either exchange or the money back. Also I have investigated my credit

accounts before the merchandise left the store, not after. The result is that I have had no repossess, my accounts are in good shape and I have a minimum of returned records. I had two brought back the other morning. One woman brought back a record that she had bought the day before. She said that 'it looked funny on her machine and did not play well.' I put it on a machine and found that it was warped. Of course, we exchanged. The other woman brought in a record that she had taken home four days before. One of the children had dropped a receiver with a needle in the record.

"I said: 'Madame, I cannot exchange that. Your request is the most preposterous thing I ever heard of.' She became indignant and said that the store exchanged damaged merchandise in all other departments. 'Why I can get gloves, wear them a week and return them if they have a rip in them,' she told me. I stood firm and she finally accepted my view.

"I can easily see where our record profits would go if we accepted such pleas. I am planning that as soon as we get our shelving extended back over the new booths to seal all records, play only the master record for demonstration and then deliver sealed records to the customer. When that seal is broken exchange will be impossible except for factory faults. Of course, if the customer buys a record and wants it proven perfect we will play it without being subject to approval as to the music."

The Famous & Barr in declining to send out machines on approval has taken a step that neither of the other department stores selling Victrolas has yet attempted. It is understood that this method of doing business has brought to this department the exclusive department store sale of the Edison disc machines.

In order to extend his department to meet with

business requirements Manager Ligon has been compelled to make a showing that would change the general plans of the store. First, he ousted Manager Vernon, of the piano department, and his office force from their office quarters. Mr. Vernon is Mr. Ligon's immediate superior, too. Now he is ousting the photographer from quarters next to the elevator. Just where he will spread to next is hard to see. The piano and talking machine departments now have a new office built, where their accounts will be handled and all collections will be made within the department, which makes them practically a special store in the big department establishment and gives to them control of every angle of their business.

RECORDS THREE TIMES A MONTH.

Columbia Graphophone Co. to Issue Lists Three Times a Month, Starting with March 1.

As announced in last month's Talking Machine World, the Columbia Graphophone Co. has perfected plans whereby new records will be offered to the trade three times a month instead of once. Starting March 1, this plan will go into effect, some special record or group of selections being issued on the 1st, 10th and 20th of each month. On the latter date the regular monthly supplement of new records will be issued, while the special popular records of various types will be issued on the 1st and 10th.

In accordance with this idea the company will issue the first of next month "Camp Meeting Band," one of the popular hits of the day. Appropriate literature and window posters will accompany each record, and the company feels certain that the new plan will be found a marked success.

A meeting of the creditors of John J. Rooney, talking machine dealer of New York City, who recently failed, and whose business, as reported elsewhere, was disposed of, was held in the offices of Seaman Miller, the referee in bankruptcy, 2 Rector street, on February 13.

READY REFERENCE OF GENERAL SUPPLIES

DEALERS

Send for our "Trial Proposition" on the Regina Hexaphone—the latest and best paying popular priced coin-operated instrument for use in public places.



211 Marbridge Bldg., 34th St. and Broadway, New York City
Manufacturers of Regina Music Boxes; Reginaphones; Coin-operated Mandolin Orchestrions; Vacuum Cleaners and other specialties.

Mermod & Co.

505 Fifth Avenue New York

Manufacturers of

Talking Machine Supplies

Motors—Sapphire Points

Diamond Points a Specialty

Keep Your Record Stock with



Costs about \$2.00 for 250 records for 50 years
Send for 20-page catalog

THE SYRACUSE WIRE WORKS,
SYRACUSE NEW YORK



The announcement of the Columbia Grafonola "Jewel" at \$35 is the most significant trade move since the announcement of the Columbia Grafonola "Favorite."



(Write for "Music Money," a book "full of meat" for those dealers interested in quick and frequent turnover of capital.)

Columbia Graphophone Company
Woolworth Building, New York

DANCE RECORDS PROVE GREAT BUSINESS BUILDERS.

Enormous Sales of Dance Records and Machines by Columbia Graphophone Co. in St. Louis—Dealers Complain of Scarcity of Records—Victor Business at Aeolian Hall—Many New Edison Dealers Appointed by Silverstone Music Co. During Month.

(Special to The Talking Machine World.)

St. Louis, Mo., February 9.—There was by no means the usual break in the machine or record business following the holidays, according to Sales Manager Duffy at the Columbia. The Columbia store has been making a special advertising campaign on the dance music records, and they have proven a great business builder, as St. Louis has been, in common with the rest of the country, "dippy" over the new dances, and the sale of a dozen records of this kind to a single customer or to a stranger has not been unusual. Most of the advertising has been of the reading notice variety, and so placed in the newspapers that it was best calculated to catch the eye of the very reader sought.

"Our machine sales have been more than we expected, and the dance music records have given the record sales a big boost," said Mr. Duffy. "We have been busy all month and will make our usual showing by comparison with previous months."

The country trade is in good shape too, according to Manager I. W. Reid. "Collections have been very good," he reports, "and are improving. For a short time collections of mercantile accounts looked bad, but that soon blew over. Our salesmen have been booking good orders, from which it can be seen that they have not found the dealers overstocked after the holiday trade. Constant inquiries that reach us indicate the general growth of the business. They come from all parts of the trade territory and from all sorts of establishments. One of the recent ones was from a butcher and grocer in a small town, who declared that he had some business to deliver if he could get a merchandise stock. We absolutely have no fault to find with business under present conditions."

E. C. Rauth, of the Koerber-Brenner Music Co., is planning to start for New York February 10 and will remain in the East until after the meeting of the executive committee of the National Association of Talking Machine Jobbers.

Harry Levy, manager of the talking machine department at Aeolian Hall, says: "The talking machine business for January in all departments was simply phenomenal, and I doubt if any person anticipated that the trade would hold on as it has. In our jobbing and retail departments we have been doing all the Victor business the stocks would allow. The record business has been immense."

Manager Robinson, of the Thiebes piano department, is reaping a rich reward from some consistent and well displayed advertising he has been doing for his talking machine department. The advertisements have been in excellent taste and have been of a sort to put people to thinking. One of them was based on "Music as a means of development." It was illustrated with pen pictures of a boy and a girl listening to the music of a machine.

The opportunity to select the Victor or Edison disc in the Thiebes parlors has continued to be a drawing card. Service letters, properly timed, also have been a splendid means of drawing in names of prospects.

"There is only one fly in our ointment at present," said Mr. Robinson, "and that is the scarcity of records that are in demand. The situation has become somewhat embarrassing, and I am hoping that the situation will be cleared up in time to put the trade in a good humor for the summer. We retailers are certainly between two fires at present, because with this popular vogue, people are insistent on getting what they want when they want it."

The reports from the other dealers are in line with these quoted. Everybody appears certain that the gains already made in business are only a beginning of what is to come.

"The Edison disc business went forward in January just as it did in December. Each month sets a mark a little bit higher than the month before," said Marks Silverstone, president of the Silverstone Music Co., Edison jobbers for this territory. "We have this month been pushing our campaign for new dealers and we have met with remarkable success. Our object at present is to prepare for the extensive advertising campaign in conjunction with the advertising that will be put out from the main office. We are being flooded with applications for retail stocks and we are, in many cases, making a selection of the various stores offered in towns and accepting those which we are assured are energetic and willing to undertake a reasonable amount of publicity.

"Best of all, our new dealers are entering into the trade with enthusiasm and they have implicit faith in their merchandise. Also our machine sales, especially here in the city, have reached a volume where the record trade is beginning to be an item and because we have catered chiefly to persons who have been able to buy high-priced machines on short time payments, they are mostly in the market for the new records as they come out, and the neighborhood dealers appreciate this."

Some of the new dealers Mr. Silverstone mentioned were: Famous & Barr department store, St. Louis; Lehman Music House, East St. Louis; F. W. Rabbe, 1800 Cass avenue, St. Louis; Mauer Music House, 1926 Gravois avenue, St. Louis; F. C. Woolsey, Fort Scott, Kan.; Eastman Jewelry Co., Petersburg, Ill.; C. H. Hawke, Greenville, Ill.; M. Y. Rusk, Brookfield, Mo.; F. C. Haley, Louisiana, Mo.; Peoria Phonograph Co., Peoria, Ill., and Jenkins Music Co., St. Joseph, Mo.

O. A. Reynolds, traveler for the Silverstone Co., reports that on his recent trip through Missouri, a part of Kansas and a little of Illinois, he found dealers' stocks very low and everybody ready to place orders for immediate delivery. He reports the efforts to push the higher priced machines

meeting with great success everywhere and the appreciation of the instrument is largely that of a musical instrument.

Mr. Silverstone, who is preparing for a trip to the Edison factory to be a guest on Mr. Edison's birthday, is taking a good deal of satisfaction over the recent placing on the market by the company of a device for playing lateral cut records on the diamond disc machine.

Raymond J. Fischel has been installed as manager of the dictating machine department of the Silverstone Co.; vice-president J. K. Savage, who retired, will take up other property interests.

A new demonstration room has been completed at the Silverstone warerooms, and the office arrangement has been changed to accommodate the growth of that part of the business.

LETTER FROM VERNON CASTLE.

Epistle Written by the Internationally Famous Dancer to the Columbia Co. Is a Tribute to the Dance Records Made by This Company.

The Columbia Graphophone Co. is appropriately featuring the following letter sent to it under date of January 1 by Vernon Castle, the internationally prominent exponent of the modern dances:

"I want to congratulate you on the excellent dance records you have recently issued; they are the best I have heard. I am using a Columbia Grand Grafonola and Columbia records at Castle House, where they are attracting extraordinary attention. The records are played in perfect dance time and are frequently encored by our patrons.

(Signed) "VERNON CASTLE."

Mr. and Mrs. Vernon Castle have been appearing for the past few months in the leading vaudeville houses on Broadway, where they have been invariably featured as headliners, commanding salaries in excess of the sums paid world-famous vaudeville stars of many years prominence. Their act consists solely of a rendition of the modern dances, which have taken the country by storm, and their interpretation of the spirit and meaning of these dances is considered authoritative in all parts of the country. Mr. and Mrs. Castle have but recently determined to confine their art solely to private exhibitions, and they are in demand by the best-known members of society.

CHANGE IN EUREKA, CAL.

(Special to The Talking Machine World.)

EUREKA, CAL., February 6.—The Eureka Co., Eureka, Cal., has changed hands, W. B. Bailey and W. H. Heaseman assuming full control. They handle the Edison and Victor lines, and are doing a fine business. These gentlemen have the reputation of being first-class salesmen, and they are right when it comes to hustling business. Their trade is steadily increasing.

"Training may make the artist, but nature gives the voice," says Mme. Melba. When the prima donna was a child at school the other children used to say to her: "Nellie, do make that funny noise in your throat." The "funny noise" was the future prima donna's natural trill.

THE RECORD SITUATION

THE MAIN ISSUE OF YOUR BUSINESS TO-DAY

We have had a problem to meet in being **SHORT OF RECORDS.**

A customer came in yesterday. His first remark was: "ISN'T THE RECORD SITUATION AWFUL?"

Our reply was: "Has your business been larger up to date this year than last year's corresponding period?"

"Why—yes," said the customer.

"Then tell us just how is the shortage of records affecting you."

He answered: "Why, we cannot fill our orders."

"Then where does the increase in your record business come from?"

He replied immediately: "We are pushing the good **STOCK** records—the records **WE HAVE.**"

MR. DEALER—that same situation can be handled every month in the year.

SHORT OF RECORDS AND A CUSTOMER LOST—but, **SHORT A FEW RECORDS AND YOU MAKE A FEW GOOD SUBSTITUTIONS**—THEN A **SATISFIED CUSTOMER.**

Our stock is the biggest in the country. In spite of the shortage, we are probably averaging the largest percentage in order filling.

No matter **WHERE** you are situated. **FORGET THE FREIGHT** and **GET THE GOODS.**

We won't claim to fill your order complete—but if we give you just a few of the ones you want—**isn't it worth while?**

New York Talking Machine Company

81 CHAMBERS STREET

NEW YORK CITY

OPERA HELPS TWIN CITY TALKING MACHINE TRADE.

The Prominent Dealers in Minneapolis and St. Paul Take Advantage of the Visits of the Chicago and Canadian Opera Companies to Give "Opera Concerts"—Activity Most Pronounced with All the Leading Concerns, Covering All Makes—News of the Month.

(Special to The Talking Machine World.)

MINNEAPOLIS and ST. PAUL, MINN., February 8.—Musical artists, of whom there have been a shoal in the Twin Cities during the present season, have done much to exploit and advance the sale of talking machines, and by a nice system of reciproca-tion the talking machines have done much for the artists to enhance their repute and mayhap line their pockets. The artists get their favors through the Victor, recitals arranged by the various houses, notably the Talking Machine Co., W. J. Dyer & Bro. and the Metropolitan Music Co. Archie Mathies, of the first-named company, issued a season's program of recitals in which he heralds the advent of every prominent musical star, whether in concert or opera. This week he gave a recital with numbers by Alma Gluck, William Bachaus and Kathleen Parlow, pianiste. Next week there will be a Marie Rappold concert, then "I Pagliacci," "La Traviata," John McCormick, Clara Butt and Mischa Elman and the programs of the Canadian Opera Company and the Chi-cago Grand Opera Company. If the artists and performances make a big hit there is a big run on their records. Hence the wise dealers push hard for the concerts and operas, for the returns are immediate.

W. J. Dyer & Bro., as a curtain raiser to the Chicago Opera Company season in April, will give "Rigoletto," "Manon," "La Tosca" and "La Boheme," programs with descriptive readings by Mrs. Berna Lapham Wells. A more instructive arrangement hardly could be made, and it is cer-tain that these recitals will be well attended by music lovers and that they fully will appreciate the opportunity. The Dyers still have considerable difficulty in keeping their Victor lines filled and complain that they have been hampered a great deal during the past four months by inability to obtain goods.

Foster & Waldo had excellent trade in Victor machines and have more than doubled their sales. With a score of outside salesmen of the piano department also instructed to pick up the talking machine prospects, the Victor department has a mighty pulling power that brings in business in and out of season.

Laurence H. Lucker, of the Minnesota Phono-graph Co., the Edison boomer, boasts of a 100 per cent. increase in the January trade as compared with that of January, 1912.

"We are selling the Edison disc machines to the best musicians and schools in the Northwest," he remarked. "Recently we have sold to the North Dakota Normal at Minot, the South Dakota Nor-mal at Brookings, the State school at Faribault, Minn., St. John's University at St. Cloud and other institutions demanding the best music. We have sold Edison machines to Richard Czerwonky, con-

certmeister of the Minneapolis Symphony Or-chestra, and Franz Dick, a member of the same orchestra. We sold a \$400 machine this week in North Dakota and one in St. Peter for \$425.

ARTISTIC VICTOR WINDOW

Featured by the J. W. Carter Music Co., of Houston, Tex., During Carnival Week—Re-ports Very Large Volume of Business.

(Special to The Talking Machine World.)

HOUSTON, TEX., February 8.—The accompanying photograph presents a portion of the show window



Carter Window During Carnival Week.

featured by the J. W. Carter Music Co., of this city, showing its artistic appearance during car-nival week. This enterprising house, which han-dles the Victor line exclusively, makes a hobby of

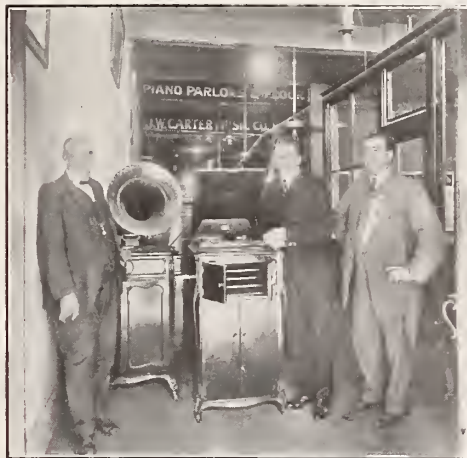

Interesting Photograph Taken at Carter's.

its show windows, and its carnival window was certainly calculated to attract favorable comment and attention.

"One of our ladies, Miss Bessie Meyers, went up to Fargo, N. D., last week to give a concert and brought back orders for eight machines, all high priced ones. These incidents, taken in connection with the ordinary run of business, make us feel just a little proud."

The Columbia house, managed by Jay H. Wheeler, is having a nice line of trade. "We are putting out machines all the time, the record busi-ness rapidly is increasing and above all collections are fine. What more does a manager want?"

In the second picture shown herewith Clarence Whitehill, the well-known baritone and one of the most popular members of the Victor recording staff, is shown listening to one of his own records, entitled "In the Gloaming." Mr. Whitehill is an occasional visitor to Houston, Tex., and whenever he arrives here invariably calls at the Victrola showrooms of the J. W. Carter Music Co. On the right of Mr. Whitehill, who is standing be-side a Victrola XVI, are shown J. W. Carter, president of the company, and C. D. Grubbe, man-ager of the Carter Co.'s Victrola department.

During the year just closed the Carter Music Co. closed the best Victor business in its history, and this is especially significant in view of the fact that the company's Victor trade has been in-creasing year after year. On a recent trip East, J. W. Carter, president of the company, spoke in the highest terms of the value of the Victor repre-sentation to the aggressive piano house, stating that the Victor agency offered an opportunity for increased business that no up-to-date piano mer-chant should permit to pass him.

In addition to catering to an extensive list of Victor patrons, the Carter Music Co. handles a splendid line of pianos, headed by the Knabe.

WHEN TO CUT OFF CREDIT.

The small merchant, particularly in country towns, faces a serious question. If he has been extend-ing credit to a customer liberally, it is only at the risk of losing all his future trade that he dare cut off that credit, and yet to continue extending credit after a man's account becomes dangerous often is fatal to business.

The best way is to have a fixed and certain rule at the opening of an account as to exactly how far you are willing to extend credit. Then, when the stipulated amount is reached, the customer has no right to feel aggrieved.

The Twenty-third street retail store of the Columbia Graphophone Co. is closing a phenom-enal business in Columbia dance records which is due in a considerable measure to the original ideas of Hayward Cleveland, the veteran man-ager of this store. Mr. Cleveland recently sent out to his extensive mailing list a neat and at-tractive four-page booklet entitled "Modern Danc-ing and the Grafonola," which discussed in a brief, though informal way, the value of a Graf-onola in the rendition of modern dance music.

Time is money, provided you don't spend a dollar's worth of time trying to save a penny.

HERMANN THORENS, Ste. Croix (Switzerland) TALKING MACHINE WORKS

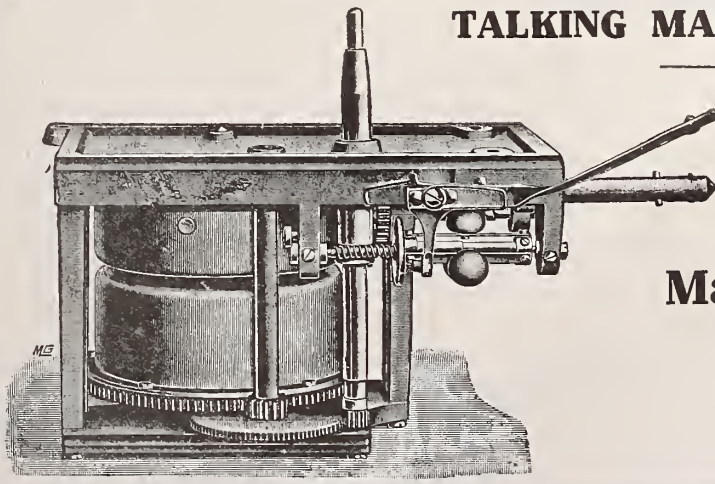

Motors and Sound Boxes a Specialty

CONCEDED TO BE THE BEST MANUFACTURED

OVER THIRTY DIFFERENT STYLES

Machines with or without Horns

FIRST QUALITY ONLY

Noiseless Motors

HIGHEST RECOMMENDATIONS

WRITE FOR DESCRIPTIVE CATALOGUE

THE TRADE IN BOSTON AND NEW ENGLAND

JOHN H. WILSON, MANAGER, 324 WASHINGTON STREET, BOSTON, MASS.

(Special to The Talking Machine World.)

BOSTON, MASS., February 9.—The talking machine business for January has been good, but of course does not compare with December, which always is the banner month of the year. Naturally all the prospects that could be developed during the holidays were taken care of, and with the expenditures of the Christmas month there is not much money left for January purchases. One of the interesting features of the talking machine business is the number of large houses that are making overtures to take on Edison, Victor or Columbia outfits. This is particularly true of prominent furniture concerns throughout New England, which heretofore had to be approached by the jobbers, and who in some cases took hold of the proposition reluctantly. Now the conditions have materially changed and all of them are viewing the proposition eagerly and expectantly, for they see in it something of permanent value, and that the talking machine proposition is something that is bound to grow rapidly.

A Time for Everything.

The World correspondent went into a Boston store on two Fridays lately—it was one of the largest concerns in the city—and found the janitor engaged in the process of cleaning up. Now it is most commendable to keep an establishment looking clean and neat, but there are proper times to do it, and that time is scarcely the middle of the afternoon. At the store in question all the Oriental rugs were off the floor and the sweeping that was going on was attended with more or less dust, which certainly was not pleasant for two women customers, not to mention several men, who were in the place at the time. What if Friday is the traditional sweeping and dusting day. Isn't the proper time to clean up a store before it is opened in the morning or after it is closed for the day?

Folk Dance Demonstrations.

Mrs. Soule, of the Carr School, Somerville, gave another of her folk dance demonstrations with a group of pupils from the ninth grade at the Grafonola parlors of the Columbia Company on Saturday morning, Jan. 24. Many of the numbers, some of them being Norwegian, Spanish, Swedish and American, were danced to the strains of familiar orchestral records. There was a large audience present and the value of the Grafonola as an inspirational and energy-saving aid was fully demonstrated.

Call from Dealers Very Large.

Manager Silliman, of the Pardee-Ellenberger Co., says the Edison disc proposition has just caught on in great shape. The call from dealers has been surprisingly large, and with the traveling staff out through New England the Boston office has about all it can do to handle the orders.

New Edison Representative.

Manager Silliman has made some strong connections lately throughout New England. Henry W. Berry & Co., of 436 Massachusetts avenue, Cambridge, a large furniture house, has just added the Edison disc line, and the manager of the department is pushing it for all it is worth. W. W. Ballard, of Salem, is another who has added Edison disc outfits to his department. Others who have made arrangements through Manager Silliman to handle this line are B. J. Kelly & Co., of Morrisville, Vt.; J. W. Johnson & Son, of Newport, N. H.; W. A. Allan, of Andover; the Atherton Furniture Co., of Pittsfield, and C. F. Wing & Co., of New Bedford, one of the largest concerns in Southern New England handling the talking machine proposition.

Good Advertising Stunt.

One of the advertising "stunts" of Manager Erisman, of the Columbia Co., was the issuance of cards advising its patrons to attend the concert at the Boston Opera House on Sunday night, February 1, when the contributing talent included Constantino, the celebrated tenor, and Jose Mardones, the great bass, both of whom sing for the Columbia. The airs that were mentioned on the card were those which could be procured on Columbia records.

Street Cars Help Sales.

Manager White, of the Victor department of the Henry F. Miller Co., has found a steadily growing demand ever since the surface cars were put back on Boylston street following the work of excavating for the subway. Lately he sent a good-sized consignment to a customer in Peru, South America, consisting of an expensive Victrola and a carefully selected assortment of records.

Keeping Things Hustling.

Herbert L. Royer manages to keep things hustling at the Arch street Victor quarters of the M. Steinert & Sons Co. Between the Boylston street store and the Arch street place the Victor business of the Steinert house is a large one. Manager Royer has now around him a carefully

selected staff of men, and with the frequent chats he gives them on business efficiency they are developing into clever and far-seeing salesmen.

Takes on the Edison Disc Line.

Walter J. Bates, of 170 Summer street, is one of the latest to become a distributor of Edison disc phonographs and outfits. He is near the South station in Dewey square, and if one prefers to consider the Columbia or the Victor proposition he can supply one with what he wants.

Reports Lively Demand.

George Lincoln Parker is finding a lively call for all the various kinds of talking machine outfits, and the fact that his quarters in the Colonial building are so easily reached by elevator makes them a very convenient place.

F. H. Thomas Co.'s Store Well Patronized.

Well equipped demonstration rooms on the Exeter street side of the F. H. Thomas Co. store at 691 Boylston street are the rendezvous of many Back Bay people who have become interested in the Edison disc machine. The fact that this place is near the Hotel Lenox is something in its favor, as many of the grand opera stars make that hotel their home while singing here.

Victor Outfits in the Schools.

Billy Fitzgerald, of the Eastern Talking Machine Co., says it is most surprising the way that outfits have been taken by the schools, and he adds that there is not a single private school in the city that is not equipped with a Victor outfit and the accompanying course on "What We Hear in Music," which is proving so valuable to music lovers and those bent on a finer appreciation of the art. And Billy is working hard with the public schools, too.

Demonstration of Sound Waves.

A most interesting demonstration of sound waves was made lately in one of the Lowell Institute courses of lectures at the Massachusetts Institute of Technology. The course was given by Professor Dayton C. Miller, and during his third lecture on "Sound Analysis" he used a flute, cornet, voice and Victrola, the latter being generously furnished the professor by the Eastern Talking Machine Co. The discs used included the "Rigoletto" quartet, a Caruso selection and a piccolo number. All the numbers were played through a horn into another horn, the sounds becoming graphically and clearly visible to the eye when thrown on a screen, showing conclusively how science has come to the aid of recording and

P-E
SERVICE

**Real Music
At Last**

P-E
SERVICE

The main thing that you sell when you are an Edison disc merchant is music—real music—the kind of music that makes a man long to spend his evenings at home. This is the reason why so little salesmanship is required of Edison disc merchants, and low selling cost means big profits.

It isn't even necessary that you should have any experience as a phonograph man, for part of our service to you is along educational lines in order that you and your salesmen may do the greatest amount of business. This is real service and co-operation that means results.

Boston, Mass.

**THE
PARDEE-ELLENBERGER
CO.**

New Haven, Conn.

THE TRADE IN BOSTON AND NEW ENGLAND

JOHN H. WILSON, MANAGER, 324 WASHINGTON STREET, BOSTON, MASS.

photographing sound waves. It is of interest that experimental work has been going on for some time at the Institute of Technology with a Victor which has been furnished by the Eastern Company, and the results arrived at through the use of different needles has been one of the many interesting developments of the experiments.

Takes a Star Part.

The dictagraph such as is used in "Under Cover," that intense play of adventure and detective ability that is crowding the Plymouth Theater at every performance, is on exhibition at the Eastern Talking Machine Co.'s Fremont street quarters, and is attracting much attention. Just what this remarkable instrument is able to do gets about the best demonstration in "Under Cover" that it possibly could have, and a study of the device whets one's desire to see the play.

Some Effective Publicity.

Joseph Santley and his musical show, "When Dreams Come True," are getting good advertisement through the postal cards which are being distributed through the Columbia Graphophone Co.'s offices. On these postals is a small disc record of one of the selections from "When Dreams Come True," which really plays fairly well. On the card is the stamp of the Columbia Co.

Larger Chickering & Son's Victor Rooms.

Since Manager Currier has taken hold of the retail quarters of Chickering & Sons the Victor department, so ably managed by Brother Batchelder, has been moved from the basement of the establishment to the second floor. The new quarters are approached by a flight of easy stairs, and at the rear of the store is the elevator if one wishes its use. The rooms are most attractive and much larger than the old quarters, and with

STANDARDIZING CATALOGS.

Effort to Make Them of Sizes Suitable for Filing Winning Approval in Business Institutions Throughout the Country.

The inconvenience of filing for purposes of reference catalogs of all sizes and shapes has prompted the Technical Publicity Association, whose membership comprises the advertising managers of many of the largest business houses in the country, to start a campaign for uniform sizes of catalogs. Definite proposals have been prepared by the association, and will be sent out this week to all of the leading manufacturers, wholesalers and retailers.

The chief recommendation is that two sizes be adopted as the standards for all catalogs, 6 by 9 inches, and 8½ by 11 inches. It is argued that if every house that issues a catalog will have it made up in one of these sizes, it can then be filed for reference with hundreds of other catalogs by any one receiving it. At present, the Technical association's circular points out, because of their varying sizes, catalogs unnecessarily take up valuable space, and cannot be filed and indexed in any way that will make reference to them easy.

The plan to standardize the catalogs has met with the approval of many advertising and catalog men associated with large manufacturing firms. The chief of the catalog department in one firm said recently that there was every reason for the adoption of the idea and none against it.

"Many catalogs," he said, "contain matter of permanent value, such as standard tables, decimal equivalents, engineering statistics and the like, and should be kept in a ready reference cabinet or closet by department managers. At present, however, it is practically impossible to keep them so that they can be of any use. I recently measured the catalogs of 700 houses and found 147 different sizes among them. They varied from pocket editions to immense books that would almost cover the top of a desk. How can such a collection of books be filed in any sort of systematic manner!"

"The only possible objection to standardization

the assistance of two able clerks Manager Batchelder is equipped to largely increase his business.

Victor on the Stage.

In "Years of Discretion," playing at the Tremont Theatre, next door to the Eastern Talking Machine Co.'s establishment, there is a Victor used, and this instrument has been furnished by Manager Taft, of the Eastern Co. The outfit plays an important part in the progress of the play.

Non-Partisan Meeting Place.

During the recent mayoralty campaign the Eastern Talking Machine Co.'s offices assumed the aspect of political headquarters, as several of the men prominent in the campaign, who happened to be Victor enthusiasts, dropped in on Billy Fitzgerald and the other boys quite often. Mayor James M. Curley (he then was only a candidate for the office) was a frequent caller, and a large picture of him and his family now adorns the desk of Fitzgerald. Collector Joseph A. Maynard was another of the political callers. Both the Mayor and the Collector possess Victor outfits.

Featuring the Columbia Grand.

Miss Mabelle Jones, who has been unusually successful in interesting patrons in the \$500 Columbia grand, has been spending a part of this month at the Atherton Furniture Co.'s place in Worcester, where she has been giving some successful demonstrations.

Visit Columbia Headquarters.

When Manager Arthur Erisman, of the Columbia, went over to New York a short time ago to confer with the home office officials, and he took with him C. A. Hewett, in charge of the graphophone department of C. A. McArthur & Co., of Boston. Mr. Hewett was thus able to come in personal touch with many of the Columbia officers.

of catalog sizes," he continued, "is that each manufacturer or wholesaler wants individuality in his catalog. But individuality can be obtained in color and thickness just as well as in size. With all catalogs printed in two sizes, each manufacturer can adopt a certain color and thickness that will distinguish his catalog from all others."

The difference between an optimist and a pessimist is that one believes in mascots and the other in hoodoos.

NEW VICTOR AGENTS IN BOSTON.

Wholesale Department of the Eastern Talking Machine Co. Make Many Successful Business Connections in Boston and Fall River.

(Special to The Talking Machine World.)

BOSTON, MASS., February 5.—Manager Chamberlain, of the wholesale department of the Eastern Talking Machine Co., has been most successful of late in being able to interest large concerns in the Victor proposition. Among the houses to recently take on these machines are the A. McArthur Co., of Washington street, this city, which already has developed a large talking machine business; Kraft, Bates & Spencer, Inc., of Boylston street, a piano house, which has had a talking machine department for some time, and George H. Munroe, of Fall River, one of the leading piano houses of that progressive city.

OPEN EDUCATIONAL DEPARTMENT.

The Outlet Co., of Providence, R. I., Perfecting Plans for Its School Campaign.

(Special to The Talking Machine World.)

PROVIDENCE, R. I., February 9.—An educational department recently has been opened at the Outlet Co.'s large establishment in this city, and its special work is exploiting the sale of Victor machines and special records in the schools. H. C. Johnson, the new manager in charge of this work, has met with marked success, due in large measure to his entirely original methods of procedure, and he has been able to convince any number of school principals and teachers of the wonderful results that can be attained by the Victor equipment in the education of children along music lines.

HOLD ANNUAL CONCERT AND DANCE.

(Special to The Talking Machine World.)

BRIDGEPORT, CONN., January 31.—The fire department of the American Graphophone Co. held its third annual concert and dance Wednesday evening at the Colonial Hall in this city. A number of prominent Columbia artists were in attendance, including Fred Van Epps, Ada Jones, Byron G. Harlan and Henry Burr.

There are many qualities of steel but only
the best steel is used in making

BAGSHAW NEEDLES

It took a lot of experimenting to secure the formula for the steel used in Bagshaw needles, for we know that the talking machine needle, while small, is one of the most important parts in sound reproduction. The temper must be exactly right, so that in manufacturing the point of the needle will be perfect. Examination of a Bagshaw-made needle under a strong glass proves this.

The steel must be firm enough to play on the record, and to do so without injuring the record. This needle quality is known to many jobbers and dealers, which is responsible for the fact that Bagshaw-made needles have the largest sale in the world.

W. H. BAGSHAW

Lowell, Mass.

Established 1870—pioneer needle manufacturers

THE TALKING MACHINE AS CIVILIZER IN THE PHILIPPINES.

A story of unusual interest is represented in the accompanying photograph showing a group of natives in the far-away Philippine Islands listening to some of their own records, which had been made for the Columbia Graphophone Co. by an

recording purposes. Dean Worcester also found the dictaphone of considerable assistance in the daily routine of his research work. Dean Worcester is shown at the extreme right of the photograph.



Members of One of the Philippines Tribes Listening to Their Own Records.

expedition under the guidance of Dean Worcester, who is famous for the constructive and uplift work that he has been doing in the Philippines. It may seem somewhat unusual to use a dictaphone for recording purposes, but in the absence of any regular Columbia dealer in this territory the dictaphone was found invaluable for

The natives in this section of the Philippine Islands are called Igorots, and their records consist of vocal selections and native songs which they rendered on the nose flute, an instrument decidedly original and distinctive. The tonal merits of these records will be a matter of considerable interest to people the world over.

BALTIMORE'S BUSY MONTH.

Talking Machine Dealers All Enthusiastic Over the Fine Business Transacted in January—Almost Impossible to Supply the Demand for Records—The Outlook for the Spring Months Is Excellent and Is One of Optimism with Every Dealer in the Monumental City.

(Special to The Talking Machine World.)

BALTIMORE, Md., February 7.—Remarkable as it may seem, the dealers here announce that figures for January show a very unusual result for this month of the year. They not only pass those for January, 1913, but all hands declare that they show a substantial increase over those for any other month during 1913 than December. There are probably no more enthusiastic individuals than the talking machine men these days, and they are emphatic in their statement that they are going to bend every effort to make 1914 go 1913 one better. Judging from the results of the last month it would seem that they are on the right road to success.

Manager W. C. Roberts, of E. F. Droop & Sons Co., announces that both the wholesale and retail trade have taken a wonderful spurt and that January was a fine month. Of course, it did not equal December, and Manager Roberts declares that had it beaten December he does not know what he would have done to accommodate the customers and properly care for the stock necessary. The capacity of his store was taxed to the climax during December, and if this condition continues he will have to make substantial extensions.

Manager S. A. Denison's business barometer is still in its accustomed place, and this indicates that business with the Columbia line has not dwindled. Mr. Denison, of course, is manager of the local branch of the Columbia Phonograph Co., and the barometer in question is his little slate which hangs back of his desk, and which tells concisely and in

a few words just what results were obtained each month. The announcement this time is simple and to the point, and runs thus: January beat any month in 1912 and 1913, except December, 1913. Mr. Denison declared he is going to do his part to make 1914 the real year in talking machine annals.

Reports from the Sanders & Stayman Co., Inc.

state that both the Columbia and Victor lines were in big demand during the past month.

Joseph Fink, of the Fink Talking Machine Co., said that January was his biggest month, and he is most enthusiastic. He had a good run on the high-priced Victors and also had many calls for the latest records.

Another firm that was in the limelight during January was the Peabody Piano Co., who have been making steady strides toward the top in the talking machine business.

INTRODUCE NEW LABEL

For Victor Records Which Was Designed and Perfected After Extended Thought and Consideration—Space for Private Number.

Beginning with the Victor records presented in last month's supplement, the Victor Talking Machine Co. announced to the trade a new label on Victor records that was designed after extended thought and consideration. A change from the former label had been contemplated by the Victor Co. for some time, as there were several minor objections connected with this label that the company felt sure could be easily remedied. The new label is the result of this thought.

As announced by the company, the new label embodies the following improvements over the former one: "The word 'Victor' appears so boldly that there is no chance for uncertainty as to the source of the record, even at considerably more than arm's length. Again, the type used is what is now recognized more or less consciously as Victor type—the face that has been most consistently used in Victor advertising. There is a broadening of the gold circle on either side of the label at the top, which can be written on with black ink.

"Formerly there was no space provided in which the user might put his own catalog number on the record, and by providing such a space we have simplified the process of returning each record to its proper place in the private collection. These will be of especial benefit in all the black label series. There was formerly no way of marking such records except by attaching an unsightly sticker."

The red seal records issued by the Victor Co. had their labels changed some time since, and the new labels have won the unqualified approval and admiration of the trade. The simplicity and dignity of the new label, coupled with the improvements noted above, combine to make it most artistic.

Record Service

IS WHAT YOU NOW NEED

Dealing with BUEHN assures you the best in service that can be had. Stocks of EDISON CYLINDER and VICTOR DISC RECORDS, both Domestic and Foreign, as complete as large orders and factory deliveries can make them.

Send your order for RECORDS to

LOUIS BUEHN - Philadelphia

and be convinced.



The Columbia Grafonola is more and more being recognized as the supreme instrument of music. The greatest music lovers are buying the most perfect instrument. The Columbia Grafonola, "Favorite," for instance.



(Write for "Music Money," a book "full of meat" for those dealers interested in quick and frequent turnover of capital.)

**Columbia Graphophone Company
Woolworth Building, New York**

MANY FEATURES OF INTEREST IN PHILADELPHIA TRADE.

Elaborate Demonstration of Edison Disc Phonographs and Records Gets Prompt Results—
Pennsylvania Talking Machine Co. Very Active—Progress of the New Dealers' Association—Record Supply Rather Low—Louis Buehn Reports Substantial Increase.

(Special to The Talking Machine World.)

PHILADELPHIA, Pa., February 9.—The beginning of the second month of the year finds the talking machine men of Philadelphia in the best of spirits, for they had an unusually good January. It was better than last year, every one reports, and the only unfortunate thing the dealers had to contend with was a difficulty in getting machines and certain classes of records.

Edison Disc Phonograph Demonstrated.

Several things of more than usual interest have transpired in Philadelphia recently. Last week Thomas A. Edison, Inc., gave a demonstration of its latest disc machine in this city at the Ritz-Carlton Hotel, for which they had issued 3,500 invitations. The exhibition lasted from 1 to 6 o'clock and more than a third of the invitations were accepted. Every one is most enthusiastic over the instrument and there are prospects that within the next ten days there will be a number of dealers in Edison disc phonographs in this city. After the hotel exhibition Mr. Stanton, of the Edison Co. remained in this city and gave exhibitions at several well-known piano houses. It is not unlikely that a number of prominent firms will take the Edison disc for sale here.

F. K. Dolbeer, William Maxwell and Mr. Stanton, representing the Edison Co., were here for the exhibition. They had upwards of forty of the latest and best Edison records with them. The Edison disc is at present handled here by two concerns, the most recent to take it being the Music Shop, No. 218 South Twelfth street.

Great Activity with Pennsylvania T. M. Co.

The Pennsylvania Talking Machine Co. has had the front of its building handsomely repainted with green enamel of a peculiar tint, which has been attracting a great deal of attention. They are contemplating numerous interior improvements and are now getting estimates on the building of a balcony over two-thirds of the store, with a large stairway leading up to it, and which will seat a great many people. Manager Eckhart reports that the business of his firm on the Columbia machines in January was nearly equal to that of December, and that they beat January of a year ago by more than 100 per cent. Mr. Eckhart was up the State several days this week and closed a very important deal at a very important point and secured a substantial order. He had Harold Lyle with him. He believes the firm will do a tremendous business. Among the visitors at the Pennsylvania store the past week were George Lyle, general manager of the Columbia Co., as well as Marion Dorian, the treasurer.

The Dictaphone business has also been most excellent, and they closed a number of important sales the past month and have some big things for February, one instalment being for close to 100 machines. "February," says Mr. Eckhart, "bids fair to be the biggest month in the history of the

Dictaphone in this territory." They have just had their delivery automobile painted in yellow enamel with gold letters, presenting a most striking appearance.

Hard to Get Enough Records.

G. F. Wurtele, of the Gimbel talking machine department, reports that its business in January has been most excellent and shows a big gain over last year. Plans are being formulated at present for a considerable enlargement of the department. Mr. Wurtele says that it has been unable to obtain many of the most popular of the records, otherwise it would have been able to do very much more business in January.

Weymann & Sons After High Class Trade.

Harry Weymann, of H. A. Weymann & Sons, reports that the demand for Victor Victrolas and records is almost phenomenal and their business during the year past was double that of 1912, and so far this year their sales will double those of last year. In the retail department, he says, they get most excellent results from their newspaper advertising, which is striking, and in which they illustrate the latest dancing fads and show how they can be satisfied in the home with the Victrola. They refrain from stating prices and they believe it has been the means of selling a much better class of goods, but instead they say: "Any of the Victor's new and improved styles may be purchased on convenient terms. Every instrument is guaranteed and is backed by our reputation of a half century as manufacturers and wholesale distributors of musical instruments of superior construction."

Mr. Weymann believes that this sort of advertising brings better results and a better class of people than that followed by so many houses who are continually advocating the old "small weekly payments."

New Association Making Some Progress.

It took a good while to get the thing started, but I am assured by some substantial men in the trade that the Retail Talking Machine Dealers' Association is going to go through. They are working it out on a little different basis than at first arranged. They were not able to get the signatures of all the representative dealers to become members of the association, but they have the promise of all of them, I am informed, that they are willing to sign a paper to adhere to the rule of charging interest on deferred payments. There will be another meeting within the next week or two, when those active in the organization have hopes that all the representative houses in the trade will be in attendance.

Increase in Business for Louis Buehn.

Louis Buehn reports that the business of his house in January was very good, being slightly in advance of last January in spite of the shortage of records and medium priced machines. "The shortage of records," he says, "makes it problematical as to how big our business would have been had

we been able to supply all demands. Conditions are a little better now, and the factory is supplying us in better proportion."

Machine Situation Improved.

The machine situation seems to be better all around, although I have noticed at some of the stores that there is still a shortage of the \$50, \$75 and \$100 types. Mr. Buehn believes that the indications are that business is going to be maintained for some time to come.

In the Edison dictating machine Mr. Buehn has done a splendid business and it is showing a marked improvement right along, the attitude of the big firms being much more friendly to the spending of money on devices of this kind for the facilitating of their business than they were during the last four months of 1913. They have closed some very nice business with the Linoleum Co., of Trenton; the Keystone Plaster Co. and the Tunis & Cookey Lumber Co., of this city, as well as other big concerns.

Take on New Salesman.

Strawbridge & Clothier have added to their selling force Otto Luedeke, who was formerly with a well-known talking machine house in this city. Their business has been very much better than it was last year.

LIVELY TRADE IN DENVER.

Chief Difficulty Lies in Securing Sufficient Quantities of the Popular Records to Meet Demands—Three Happy Managers and the Reasons—Other News of Month.

(Special to The Talking Machine World.)

DENVER, COL., February 6.—The talking machine trade in this city has kept up in a remarkable manner and the sales for the month of January were far in excess of the total sales volume for the same month last year, according to the reports of the various local talking machine houses. Record sales are particularly heavy and the main question with both the jobbers and dealers is that of securing a sufficient stock of records to meet the demands. The call for dance records to provide suitable music for the tango, maxixe and hesitation waltz is especially strong and the stocks of that class of records are at low ebb.

At the present time there are three local talking machine managers who are particularly happy, regardless of trade conditions. The happy ones are O. F. Kelso, manager of the talking machine department of the Denver Music Co., who is the father of a bouncing baby boy, who has already developed a pronounced taste for talking machine music; C. B. Arbenz, manager of the talking machine department of the Knight-Campbell Music Co., and W. C. Wyatt, manager of the talking machine department of the Denver Dry Goods Co., both of whom have had dainty feminine additions to their households recently.

The Denver Dry Goods Co. reports a big increase in the popularity of the Edison disc phonographs and records, for which the house has the jobbing rights. The company will be represented at the annual gathering of the Edison disc jobbers to be held in New York on the 9th and 10th,

Increase Your Record Sales

BY PLACING THIS HANDSOME FLEXIBLE COVER IN THE HANDS OF YOUR PATRONS



This attractive flexible cover is designed to hold the Victor or Columbia semi-annual record catalog, and is bound in mahogany colored imitation leather, and lined with black silk cloth.

The price of this flexible cover is so low that it permits you to give same free to your customers with the record catalog inclosed, thereby making a useful souvenir and a permanent advertisement; or you may charge a nominal sum for it if you desire.

In lots of 100 or more, your name will be stamped on face of cover in gilt lettering free of charge.

Send 20c. in stamps for a sample cover, with special trade prices.

NEW YORK POST CARD ALBUM MFG. CO., 23-25 Lispenard Street, NEW YORK
Makers of Talking-Machine Record Albums

F. K. DOLBEER HOME FROM TRIP.

Covers Principal Cities in Far West to Pacific Coast in Interests of Thomas A. Edison, Inc.—Business Conditions Generally Satisfactory Throughout the Western States.

(Special to The Talking Machine World.)

ORANGE, N. J., February 9.—F. K. Dolbeer, general sales manager of Thomas A. Edison, Inc., phonograph division, has returned from a two months Pacific Coast trip, during which he spent some time in Portland, Seattle, Vancouver, Spokane, San Francisco, San Diego, Los Angeles and other points. Leaving New York on the sixth day of December, he arrived in San Francisco inside of four days, which is a remarkably short time, particularly in winter, as stormy weather frequently retards railroad efficiency.

"I spent New Year's," continued Mr. Dolbeer, "at San Francisco and had a very enjoyable time. The city seems to go as wild over this holiday as New York, and although the rain interfered with the street processions, still the life at the hotels made up for it. This city is growing at a rapid rate and I am greatly impressed with its throbbing pulse of activity. The exposition buildings are being rapidly completed and it would not surprise me, if circumstances demanded, that the exposition could open as early as September of this year.

"As to business conditions on the Coast, it is difficult to think of a single word to cover the entire situation, for in some localities business was brisk and in others the visitor was told that general trade was not up to the usual standard. As a whole, however, the average is good and I should imagine that in some spots a slight depression were felt, the setback commercially is only temporary.

"I was very glad to witness the tremendous widespread interest on the Coast towards the Edison disc phonographs and records. Everywhere I went I heard only words of praise for the musical perfection that has been obtained in this latest product of Mr. Edison's genius. Naturally, the sales are growing very fast and there is every indication that 1914 will see a wonderful year for the distribution of these machines throughout the Coast States."

Mr. Dolbeer told about his visit to the home of Frank Hart, of the Southern California Music Co., Los Angeles, which is located eighteen miles from the city, and where he not only enjoyed eating fresh blackberries on January 11, but where he saw the most wonderful scenery. "Mr. Hart's home, comprising many acres of ground, is situated on a plateau, from which may be seen mountains, valleys, the cities of Pasadena and Los Angeles, the ocean, embracing a view that extends over many miles in all directions," added Mr. Dolbeer.

Mr. Dolbeer remained in Orange but a few days before leaving on a short trip that will take him to a number of Eastern cities.

RECEIVER FOR POOLEY CO.

Prominent Furniture and Record Cabinet Manufacturer of Philadelphia Sends Letter to Creditors Announcing Culmination of Financial Difficulties—To Continue Business.

The Pooley Furniture Co., manufacturers of fine furniture and talking machine record cabinets in Philadelphia, Pa., has sent out the following letter to the creditors of the company, under date of February 9, 1914:

"There were several merchandise suits pending against us which we have been unsuccessful in trying to get out of the way. As the suits would go to judgment on Tuesday of this week, the committee representing creditors decided, in the interest of all creditors, to apply for a receiver in equity. This was done of the 7th inst., and M. Weinmann was appointed by the court. He will continue the business, conserving all the assets in the interest of creditors.

"We regret very much that four or five creditors out of a total of 140 made this action necessary."

TAKES ON THE VICTOR LINE.

Hanford & Horton Co., Middletown, N. Y., Planning to Give the Victor Line a Live Representation in Orange County—Manager Visits New York to Complete Deal.

The Hanford & Horton Co., of Middletown, N. Y., closed arrangements last week with Thomas G. Green, representative of the Victor Talking Machine Co. in that territory whereby a complete line of Victor products will be handled. This company has been established in business for the past fifty years, during which time it has conducted a high-class leather goods, book and stationery business, catering to an extensive clientele in their part of the State.

The new Victor department will be under the general supervision of S. G. Shimer, with Mr. Kenney in personal charge. Both of these gentlemen were visitors to New York this week, calling at the offices of the New York Talking Machine Co., 81 Chambers street, New York, the prominent Victor distributor. They thoroughly investigated the stock methods and other interesting items of the business as conducted by this company and were so pleased with the ideas they obtained from this investigation that they placed a substantially larger initial order than they had originally planned.

"OFFICE MAXIXES" THE LATEST.

According to the New York World, "office maxixes" are the latest form of the dancing mania. Business men's wives have discovered that the hardwood floor of "hubby's" big office is excellent for dancing. There's no rent to pay and a talking machine furnishes the music. The office dances are generally held from 5 to 6.30 and are of frequent occurrence, especially in the automobile district.

THE SOUTHERN CALIFORNIA TRADE.

F. K. Dolbeer, of Thomas A. Edison, Inc., a Welcome Visitor—J. C. Berryman Appointed Manager of Eilers Department—Excellent Business Reports from the Smaller Towns—J. C. Clem Invents Tone Arm Amplifier.

(Special to The Talking Machine World.)

LOS ANGELES, CAL., February 5.—F. K. Dolbeer, sales manager of the Thomas A. Edison, Inc., was a welcome visitor to this section recently. While in Los Angeles Mr. Dolbeer, with O. A. Lovejoy, manager of the Southern California Music Co., visited many of the city and suburban Edison dealers, and was very much pleased with the results obtained by them.

J. C. Berryman, who has been with the Eilers Music Co., of this city, for a number of years, has been lately appointed manager of the talking machine department. This position was formerly filled by S. C. Purier, who is now retiring from the talking machine line, and has taken interest in one of the large piano houses of this city.

The Baxter-Northrop Co. is much pleased with the volume of business done in its talking machine department within the past thirty days, of which B. H. Burke is manager.

W. W. Nash, Covina, Cal., has been doing splendidly with the Victor line in his progressive little town. The popular sellers has been the Victrola XIV. and XVI.

A. P. Neilson, of Taft, Cal., was in the city for a few days, and very much enthused over the outlook of the Edison line in that great oil center.

One of the best known authorities on tone reproduction is Amct, of Redondo, Cal., who has very recently perfected a new talking motion picture, and is now in Washington, D. C., with this device. Prof. Amct has more than one hundred patents relating to talking machines.

Bowman Merritt, Fillmore, Cal., has taken on a complete line of Victor goods, also Oscar Glanville, Mojave, Cal., who increased his Victor stock.

Harry H. Clubb, an old-time talking machine man of Los Angeles, is again back in the harness selling talkers for the Wiley B. Allen Co.

C. W. Betty, Maracopa, Cal., and C. C. McGregor, of McGregor Bros., Ventura, Cal., were in the city recently. Both are live wires with the Edison line.

J. C. Clem, has produced a tone arm amplifier, 12 x 4 inches at the mouth, and giving a tone equal to that of a large wooden horn. This arrangement can be placed on any style or make of machine, the object being to increase the volume of the tone in a small space.

A. J. Morse, manager of the branch store at San Diego, Cal., of the Southern California Music Co., spent a few days in this city, much elated with the growth of business within the past few weeks.

Worthy of all acceptance and constant reiteration is this. "The ideal of modern advertising is to exalt the standard of your product in the mind of the public so that you can get your price."

EDISON DISC JOBBERS' ASSOCIATION ORGANIZED

At Meeting Held at Hotel Knickerbocker, New York, on February 9—H. H. Blish Elected First President—Objects of the New Association—Jobbers Visit Edison Factory and Are Entertained by Officials of Company—Most Enthusiastic Over Conditions.

An association of Edison disc jobbers, regarding which there has been much speculation throughout the trade, and especially since the informal meeting of a number of the jobbers in New York last August, became an accomplished fact this week when on Monday a score of the leading jobbers of Edison disc phonographs from various sections of the country gathered at the Hotel Knickerbocker, New York, and formally organized the Edison Disc Jobbers' Association, for the purpose of developing and maintaining harmonious relations between the jobbers and between the jobbers and the factory and for encouraging and aiding in all such matters as may prove of benefit to any or all branches of the trade at large.

The first officers of the new association are H. H. Blish, Harger & Blish, Des Moines, Iowa; vice-president, C. B. Haynes, C. B. Haynes & Co., Richmond, Va.; treasurer, F. H. Silliman, Pardee-Ellenberger Co., Boston, Mass., and secretary, H. G. Stanton, R. S. Williams & Sons Co., Toronto, Ont. The usual committees will be appointed by President Blish at a later date.

The jobbers as they reached New York were a most optimistic lot, full of enthusiasm regarding the manner in which, in every instance, their business had developed and of the volume of trade already handled, especially during the recent holiday season, the first season they have been really equipped in the matter of stock to go after the business energetically and to take care of it properly. Each jobber expressed supreme faith in the future of the Edison disc phonograph and cited the recent additions to his list of dealers and his plans for the future to back up his beliefs in a convincing manner.

The informal meeting called by Mr. Blish last August proved such a success and so beneficial to every one who attended that in answering this latest call the jobbers all came fully prepared to enter into a permanent organization and to give the association their strongest support. The entire day was practically given over to the perfecting of the organization and to a discussion of the constitution and by-laws and there was little time for general discussion of trade subjects, though such matters as came before the meeting were considered carefully and decided harmoniously.

When the new association gets into full running order it is the purpose of the officers to keep in close touch with every branch of the trade—factory, jobber and retailer—in order that it may exert its influence in the right direction and at the time when it will prove most helpful to the trade as a whole, and the body will take up such matters as the securing of the most favorable freight rates on phonographs, records and accessories and the general discussion and endorsement of methods that will tend to further the Edison disc interests in all sections of the country.

It is confidently expected that the few jobbers who were, for one reason or another, unable to attend the meeting will be quick to join the ranks of the association and lend their support to that body as well as benefit by the work of a representative trade organization. For some time at least no regular annual convention of the new association will be held, but the members will be called together at such times as are most convenient and when the most good can be done.

Following the adjournment of the meeting the jobbers were the guests of the officials of Thomas A. Edison, Inc., at an informal dinner at the Knickerbocker and later at the New Amsterdam Theater, where they witnessed the performance of "The Little Cafe," the representatives from the Edison factory including General Manager Charles H. Wilson, Second Vice-President William Maxwell, Sales Manager G. K. Phillips, Manager of Phonograph Sales Frank K. Dolbeer and his assistant, A. C. Ireton, Charles Edison, son of Thomas A. Edison, and others.

On Tuesday morning the jobbers made an early start and were escorted to the Edison factories in Orange, N. J., where they held a long conference with the officials of the company, with results most satisfactory to all concerned. They were then escorted through the various departments of the factory, where they witnessed the improved processes for increasing the output, especially of records, without in any way detracting from the high quality of the product. The jobbers were much gratified to learn that arrangements had been made to take care of all possible demands from them for stock in the future with little or no delay through the development of new and more rapid manufacturing systems.

One of the imposing features of the visit to the factory by the jobbers was their meeting with Mr. Edison on the eve of his sixty-seventh birthday anniversary, which occurred on Wednesday, February 11. The jobbers presented to Mr. Edison a specially prepared resolution congratulating him on his anniversary and which was accompanied by a handsome bouquet of roses. Mr. Edison was quite overcome by the tribute and could not apparently do enough to express his appreciation to his guests.

After a luncheon at the Essex County Country Club the jobbers returned to the factory, where they spent some time with Mr. Edison in his laboratory and then left for New York, either to spend a few days in the metropolis or to rush home and again take up their business reins with increased enthusiasm.

Those present at the meeting and who enrolled as charter members of the Edison Disc Jobbers' Association were: Laurence H. Lucker, Minnesota Phonograph Co., Minneapolis, Minn.; H. H. Blish and H. H. Blish, Jr., Harger & Blish, Des Moines, Iowa; Marks Silverstone, Silverstone Music Co., St. Louis, Mo.; L. N. Bloom, The Phonograph Co., Cleveland, O.; B. W. Smith, The Phonograph Co., Cincinnati, O.; H. G. Stanton, R. S. Williams & Sons Co., Toronto, Ont.; F. H. Silliman, W. C. Pardee and E. L. Ellenberger, Pardee-Ellenberger Co., Boston, Mass., and New Haven, Conn.; N. D. Griffin, American Phonograph Co., Gloversville and Albany, N. Y.; J. N. Swanson, Houston Phonograph Co., Houston, Tex.; C. B. Haynes, C. B. Haynes & Co., Richmond, Va.; Walter Kipp, Kipp-Link Phonograph Co., Indianapolis, Ind.; D. W. Shultz, Shultz Bros., Inc., Omaha, Neb.; F. B. Bolway and F. B. Bolway, Jr., Syracuse and Oswego, N. Y.; Percy Ashton, American Phonograph Co., Detroit, Mich.; W. A. Myers, W. A. Myers Sporting Goods House, Williamsport, Pa.; A. W. Toennies, Eclipse Phonograph Co., Hoboken, N. J.; Albert Buehn, Buehn Phonograph Co., Pittsburgh, Pa., and C. B. Harris, Southern Talking Machine Co., Dallas, Tex.

YOUR OPPORTUNITY

HERE IT IS

If you are one of those VICTOR DEALERS who has not tried "BLACKMAN SERVICE," can you AFFORD to not try it NOW?

Will You Ignore It?

Will you simply GO WITHOUT records you need, or will you TRY BLACKMAN? We can't give you everything wanted, BUT our service will AT LEAST be a BIG LIFT.

Send a Trial Order

Make it two or three for A TEST, and we will take a chance on OUR SERVICE, when compared with others, making you a REGULAR BLACKMAN DEALER.

DON'T DOUBT UNTIL YOU TRY

Very sincerely

BLACKMAN TALKING MACHINE CO.

J. NEWCOMB BLACKMAN, Pres.

97 CHAMBERS ST., NEW YORK





The pleasure derived from music and Columbia Grafonolas is identical—unending and increasing.



(Write for "Music Money," a book "full of meat" for those dealers interested in quick and frequent turnover of capital.)

Columbia Graphophone Company
Woolworth Building, New York

TO WORK KEEN-O-PHONE PATENTS.

Rex Talking Machine Corporation Leases Plant Equipment and Patents of Philadelphia Concern and Will Manufacture in a Big Way.

(Special to The Talking Machine World.)

PHILADELPHIA, PA., February 9.—The Rex Talking Machine Corporation was recently incorporated in this city for the purpose of manufacturing talking machines. Capitalization is \$1,200,000, divided equally between preferred and common stock. Philip Wohlstetter is president and H. W. Stoll is treasurer. It will be several weeks yet before the entire permanent organization can be announced definitely.

The Rex Talking Machine Corporation has leased the entire plant, equipment of the Keen-O-Phone Co. for a term of years, where it will manufacture a medium-priced line of talking machines and records, the complete line of which will be shown in the new machine and record catalogs that are now in preparation.

Thomas Kramer is superintendent of the factory, while the recording end of the business is under the charge of Frederick W. Hager and Charles L. Hibbard.

Philip Wohlstetter, president, in chatting with the representative of The Talking Machine World, said: "At the present time matters are in such a preliminary shape that it is almost impossible to tell the trade just what we are planning to do, although our policy is practically outlined. We hope to be able to make an announcement in March and in the meantime it can be said that we will manufacture and distribute a line of machines and records of medium price, catering more particularly to people in moderate circumstances."

SIGN UP MANY DEALERS.

Eclipse Phonograph Co., of Hoboken, N. J., Doing a Large Edison Disc and Cylinder Business—High-Class Trade Emphasized.

"Business has been keeping up remarkably well for this time of the year," stated A. W. Toennies, of the Eclipse Phonograph Co., 203 Washington street, Hoboken, N. J., the well-known Edison disc and cylinder jobbers. "Although there is a shortage in certain types of machines and in the more popular records, shipments are coming from the factory in a very gratifying manner.

"One of the pleasing features of the Edison disc business is the fact that the great percentage of this business is based on the machines selling at \$150 or over. This high-class trade is naturally very satisfactory to the Edison disc dealers in our territory, all of whom predict an excellent spring trade with the Edison disc phonographs and records. We have signed up quite a large number of new dealers during the past month, and, contrary to the pessimistic predictions of some members of the trade, the cylinder business is also going along very nicely."

If you can learn to meet to-day's trouble with a placid soul, to-morrow's problems will come to you with their answers in their hands.

FLORIDA FOR THE VACATIONISTS.

Max Landay Now a Strong Booster for the Land of Flowers After Recent Visit to St. Augustine and Other Popular Southern Resorts.

From the oldest city in America, St. Augustine, Fla., The World recently received on a post-card, portraying Max Landay, the popular Victor distributor, in the role of a vacationist rather than a Victor hustler, as will be noticed. Mr. and Mrs. Landay are pictured in one of the beautiful orange groves of Florida, and judging from all indications, are having the time of their lives picking the luscious fruit.

Mr. and Mrs. Landay returned to New York a few days since from this very enjoyable Southern



Mr. and Mrs. Landay in Florida.

vacation, but the memory of those Florida oranges still lingers, notwithstanding the fact that Mr. Landay has been working day and night to prepare for the opening of Landay Bros. newest store at 427 Fifth avenue, New York. Garnett Grove, St. Augustine, Fla., was the scene of the illustration herewith, and Max Landay recommends this spot to all tired Victor enthusiasts who are desirous of securing a store of renewed energy for their busy seasons.

"I hed a dickshonary oncet," said Uncle Zeke, "but after I found it didn't spell words th' way I did, I give it to th' depot agent. It holds his door open durin' the hot weather fine!"

OUR FOREIGN CUSTOMERS.

Amount and Value of Talking Machines Shipped Abroad from the Port of New York for the Past Five Weeks.

(Special to The Talking Machine World.)

WASHINGTON, D. C., February 9.—Manufacturers and dealers in talking machines will doubtless be interested in the figures showing the exports of talking machines for the past five weeks from the port of New York.

JANUARY 10.

Algoa Bay, 17 pkgs., \$357; Ceara, 8 pkgs., \$490; Colon, 10 pkgs., \$362; Demerara, 4 pkgs., \$108; Glasgow, 4 pkgs., \$135; Guayaquil, 4 pkgs., \$179; Havana, 13 pkgs., \$1,324; 34 pkgs., \$1,436; La Guaira, 6 pkgs., \$250; Manila, 10 pkgs., \$438; Sydney, 469 pkgs., \$29,758; Valparaiso, 3 pkgs., \$175; Vera Cruz, 710 pkgs., \$1,984; Vienna, 1 pkg., \$100.

JANUARY 17.

Antigua, 11 pkgs., \$127; Bergen, 8 pkgs., \$179; Berlin, 20 pkgs., \$617; Buenos Aires, 96 pkgs., \$1,550; Cienfuegos, 38 pkgs., \$1,864; Colon, 3 pkgs., \$292; 5 pkgs., \$137; Dublin, 2 pkgs., \$118; Guayaquil, 51 pkgs., \$2,762; 10 pkgs., \$447; 14 pkgs., \$1,639; Havana, 24 pkgs., \$2,660; Kingston, 5 pkgs., \$362; La Guaira, 12 pkgs., \$478; Limon, 9 pkgs., \$130; Liverpool, 19 pkgs., \$1,075; 9 pkgs., \$256; London, 108 pkgs., \$4,340; 1 pkg., \$300; 1 pkg., \$125; Manzanilla, 2 pkgs., \$985; Puerto Barrios, 4 pkgs., \$112; Port of Spain, 15 pkgs., \$521; Rio de Janeiro, 4 pkgs., \$788.

JANUARY 24.

Antofagasta, 10 pkgs., \$700; 2 pkgs., \$170; Barranquilla, 21 pkgs., \$2,201; Callao, 5 pkgs., \$1,146; 8 pkgs., \$339; Caracas, 7 pkgs., \$548; Christiania, 2 pkgs., \$200; Copenhagen, 2 pkgs., \$60; Havana, 2 pkgs., \$172; Havre, 8 pkgs., \$708; Kingston, 13 pkgs., \$355; La Paz, 6 pkgs., \$214; Liverpool, 9 pkgs., \$193; London, 113 pkgs., \$3,640; 14 pkgs., \$1,090; Manaos, 4 pkgs., \$128; Maracaibo, 1 pkg., \$127; Rotterdam, 14 pkgs., \$1,720; Singapore, 37 pkgs., \$1,761; Vera Cruz, 108 pkgs., \$4,055.

JANUARY 31.

Antofagasta, 35 pkgs., \$731; 12 pkgs., \$185; Buenos Aires, 80 pkgs., \$3,522; Cartagena, 13 pkgs., \$394; Colon, 25 pkgs., \$379; Delagoa Bay, 2 pkgs., \$100; Gibara, 4 pkgs., \$124; Hamilton, 3 pkgs., \$108; Havana, 15 pkgs., \$588; 8 pkgs., \$458; Liverpool, 18 pkgs., \$345; London, 177 pkgs., \$5,388; 13 pkgs., \$256; Manchester, 3 pkgs., \$169; Manila, 54 pkgs., \$2,905; Macoria, 4 pkgs., \$315; Piraeus, 2 pkgs., \$350; Rio de Janeiro, 12 pkgs., \$811; Vera Cruz, 26 pkgs., \$1,048.

FEBRUARY 7.

Bahia Blanca, 2 pkgs., \$256; Belize, 12 pkgs., \$352; Buenos Aires, 119 pkgs., \$15,492; Callao, 5 pkgs., \$162; Cardiff, 4 pkgs., \$163; Colon, 2 pkgs., \$162; Ciudad Bolivia, 6 pkgs., \$250; Genoa, 2 pkgs., \$150; Hamburg, 3 pkgs., \$195; Havana, 7 pkgs., \$239; Limon, 8 pkgs., \$437; London, 36 pkgs., \$1,389; St. Petersburg, 10 pkgs., \$220; 3 pkgs., \$705; Trieste, 3 pkgs., \$455; Valparaiso, 3 pkgs., \$141; Vera Cruz, 20 pkgs., \$759.

Welcome trials, for remember it is usually difficulties that bring a man to the fore.

ATLANTIC CITY WINS FOR 1914.

Annual Convention of the National Association of Talking Machine Jobbers to Be Held at Popular Seaside Resort This Summer—Elaborate Program Being Arranged for the Meeting—Planning for Big Attendance from All Sections of the United States.

Under date of January 16, Secretary Whitsit, of the National Association of Talking Machine Jobbers, sent out to all members a communication informing them that the executive committee at its meeting last September endorsed Atlantic City as the place for holding the 1914 convention. A return postal was enclosed with instructions to check Atlantic City if the member favored it and if not to express his choice of other cities. To date about 75 per cent. of the membership have responded and the choice is all but unanimous for Atlantic City, there being just two dissenting votes.

Now that the meeting place has been decided on work will begin at once arranging for the convention. If the 1914 gathering does not eclipse any previous one it will not be the fault of the officers in charge. Already President Roush and Chairman Wiswell of the arrangement committee have had their heads together and they have passed the word along that not only will there be more doing from an entertaining standpoint, but there will also be several innovations in the association business meetings. In other words, these gentlemen have adopted as their slogan, "something doing extraordinary in '14," and the members knowing their caliber seem to be perfectly satisfied to leave it to them.

A special effort is going to be made this year to get to the convention the heads of all houses jobbing the talking machine line, as well as their department managers.

Prior to this time a great many jobbers have considered their talking machine department as merely a side line, but association officials have reason to believe this condition no longer exists; in fact, when comparisons with other departments are made of the 1913 business it is thought that the talking machine line will have forced its way ahead of most of their other departments. This being true, there is no good reason for the heads of these concerns ignoring longer the National Association of Talking Machine Jobbers, and much pressure is going to be brought to bear to convince them of this fact. It sounds reasonable.

President Roush and Secretary Whitsit spent a day together in January talking over the important things to take up February 16, when the executive committee will confer with the Victor directors.

Once when Mischa Elman arrived at a certain city to give a recital he hailed a conveyance at the station and requested to be driven to the concert hall. "Not a bit of good—the house has been sold out this last fortnight," retorted the driver. "That is rather awkward," replied the young violinist. "But never mind, drive me there all the same. I'll take my chance of getting in."

NEW QUARTERS FOR C. W. LINDSAY.

Will Erect New Building for Quebec Branch and Give Added Prominence to Victrolas in Quebec Province—Work to Begin in May.

(Special to The Talking Machine World.)

QUEBEC, QUE., February 9.—Greater prominence will be given the Victrola line in this city as a result of the decision of the firm of C. W. Lindsay, Ltd., to erect new premises for its local branch in the city of Quebec. The results of its negotiations was the purchasing of property on St. John street, opposite its present store. This property gives it 4,252 square feet of ground on which it proposes to build a five-story steel building, containing an attractive front and all conveniences. Work will be begun on the new building in May.

FIBRE NEEDLE MASTERPHONE.

Wins Much Praise from Trade and General Public—Promises to Have a Big Demand.

"The reception accorded our new fibre needle Masterphone has been very gratifying," said M. B. Claussen, president of the Masterphone Corporation, 187 Broadway, New York. "Since announcing our new Masterphone late last month we have received orders for it from all parts of the country, as the trade having derived entire satisfaction from our steel needle device, felt confident in the success of our fibre needle Masterphone.

"Notwithstanding the fact that the new Masterphone has only been on the market for a week or two, we are already in receipt of a number of communications from music lovers who are enthusiastic over the tonal results obtained by the use of the fibre needle Masterphone. The true, natural tone of the record is not only brought out, but augmented by the use of the Masterphone, and with the endorsement of a number of famous artists who have listened to their own records as played with our new device, we naturally feel certain that music lovers throughout the country will appreciate its true musical value."

TO HANDLE THE EDISON LINE.

Two Companies Incorporated, One with Headquarters in Chicago and the Other in Kansas City—Latter to Act as Phonograph Distributors—Will Also Open Retail Store.

(Special to The Talking Machine World.)

CHICAGO, ILL., February 9.—The San Francisco Phonograph Co., which has conducted a store in this city for some time past, has been incorporated with a capital stock of \$15,000 for the purpose of handling Edison phonographs. The incorporators are: Morris Cohen, Fred Barth and Clyde E. Shorey. The same people have also incorporated the Western Phonograph Co., which will act as distributor for Edison phonographs and records, with headquarters in Kansas City. The Western Co. will open a retail store on Grand avenue, Kansas City, under the management of W. P. Hope.

CELEBRATES 65TH ANNIVERSARY.

R. S. Williams & Sons Co., Ltd., Jobber of Edison Phonographs, Holds Interesting and Successful Reception to Mark Business Anniversary—Its Sixty-fifth, by the Way.

(Special to The Talking Machine World.)

TORONTO, ONT., February 9.—A most successful anniversary reception was held on Tuesday, January 20, by the R. S. Williams & Sons Co., Ltd., of Toronto, who is the Canadian distributor of Edison phonographs and records. The occasion was the firm's sixty-fifth anniversary, and the crowds that inspected its ten-story "Home of Music," showed their appreciation of the programs rendered in the recital hall. Both the afternoon and evening concerts presented a variety of music furnished by Miss Estelle J. Carey, soprano soloist, Esther Smith's concert orchestra, the Edison disc phonograph and others. The building was most suitably decorated throughout and each floor was inspected by throngs of interested visitors. The event was announced by invitation cards and well-written daily paper announcements. This completes the first year of the R. S. Williams & Sons Co. occupancy of its splendid new building.

WIN SUCCESS WITH COLUMBIA LINE.

Music Supply Co., of Toronto, Ont., Forced to Move to Larger Quarters to Handle Growing Business at 36 Wellington Street, East.

(Special to The Talking Machine World.)

TORONTO, ONT., February 9.—The rapid increase of the sale of Columbia products in the province of Ontario has meant such expansion in the business of the Music Supply Co., Columbia jobbers for this province, that it has been forced to take larger premises, and accordingly has moved from 88 Wellington street, West, Toronto, to 36 Wellington street, East. A new feature of the Music Supply Co.'s trade is the introduction of the foreign language disc records. These give dealers a field for selling courses in French, German, Spanish and Italian, for which both the proprietors of the firm, John A. Sabine and Charles R. Leake are convinced is a very large one in Canada, and one that should yield good results to live retailers.

SUCCESS WITH DAILY CONCERTS.

(Special to The Talking Machine World.)

PLYMOUTH, N. H., February 8.—Fred W. Brown reports that his Edison cylinder business is making rapid strides. A very attractive window display of the new Amberolas has done much to draw trade, and daily concerts are the rule. During the visit of the Edison representative a number of prospects were closed, including one Amberola III to a prominent merchant of the town who is most enthusiastic over its musical and constructive merits. Business generally is excellent.

A little push will often be more effective than a lasting spell.

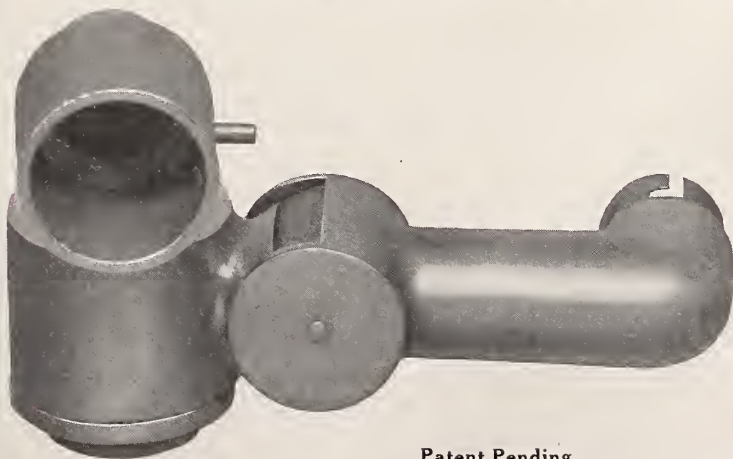
IMPORTANT NOTICE TO EDISON DISC DEALERS

Patent Pending.

The New Thomas Attachment

Plays lateral cut records on the new Edison Disc Machine. It has a patented ball bearing joint, which makes it work flexible and free. You should not fail to have a quantity of these attachments in stock, as it will greatly add to your machine sales.

Write to your jobber for a sample, if he hasn't it write to us.

F. H. Thomas Co., 689 Boylston St., Boston, Mass.

This Cabinet is built to match the machine case, and gives the impression that the two are a unit. It is a masterpiece of cabinet making, and is furnished in the various woods and finished to match. The compartments are lined with felt in the Salter style, giving perfect protection to records.

Similar cabinets for the "Columbia" line and some beautiful new cabinets for the Edison line.

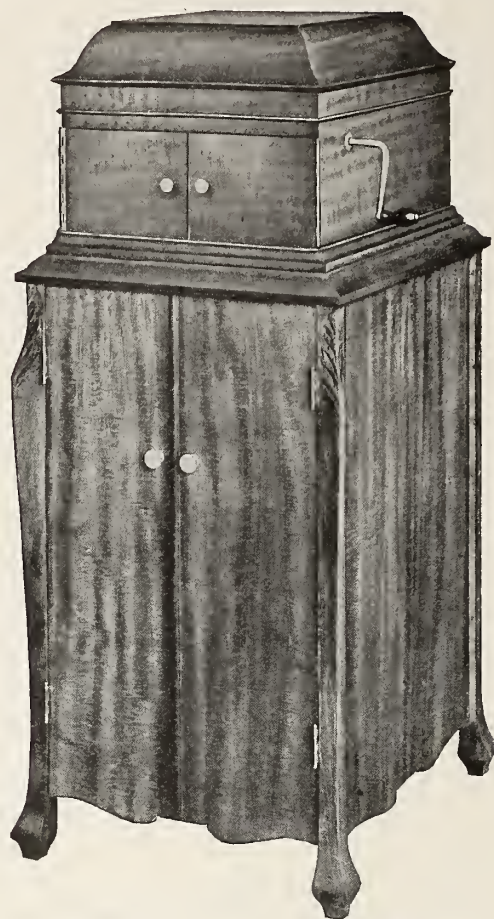

Salter Cabinet for No. IX Victor Machine.

**What would you say of
a dealer in Talking Machines
who did not handle Records?**

**You would say that he
was like his stock—"Not all
there."**

How About Cabinets?

No Talking Machine business is realizing nearly what it should unless profits from cabinet sales play a big part in the dividends.

We have looked at things from the dealer's standpoint as well as our own and have designed our cabinets with you in mind. With the Salter line profits are sure.

Have Our Catalog Handy.

SALTER MFG. CO.
337-43 N. Oakley Blvd. CHICAGO

H. J. THOMAS APPOINTED MANAGER

Of Talking Machine Department of Hobart M. Cable Co. Store in Clinton, Ia.

(Special to The Talking Machine World.)

CLINTON, IOWA, February 11.—H. J. Thomas has been made manager of the talking machine department of the branch store in this city of the Hobart M. Cable Co., of La Porte, Ind. The talking machine department is a new feature of the store and a large space will be fitted up for its accommodation, with several handsome demonstrating booths. Mr. Thomas is a talking machine man of experience, having been for four years with the Chicago branch of the United States Phonograph Co., of Cleveland, starting as a local salesman and promoted as traveling salesman and was later in immediate charge of the sales of the Chicago branch. The opportunity offered Mr. Thomas to locate in Clinton was an exceptionally fortunate one for him, as it is his old home town, and he was but recently married to Miss Jennie Lee Fairchild, an accomplished young woman of this city.

ADVERTISEMENTS NOT COPYRIGHTED

Artistic and Literary Devices May Be Protected, Not Advertising Articles, Rules Judge Foster in Decision Just Handed Down.

(Special to The Talking Machine World.)

NEW ORLEANS, LA., February 7.—That advertisements are not subject to copyright unless possessed of sufficient artistic and literary merit, is the substance of an opinion handed down by Judge Rufus E. Foster, of the United States District Court, last week, in the case of Stone & McCarrick, Inc., vs. the Dugan Piano Co., Ltd., in which the motion to dismiss was sustained. In the original bill complainant alleged that it had published and copyrighted a book entitled "Manual of Instruction, in Use of Stone & McCarrick System of Salesmanship"; that the book was specially intended for use by its subscribers for reprinting parts thereof in a series of articles intended for advertising purposes and was printed in such forms as to be specially adapted for use as "copy" for advertisements in newspapers, magazines, periodicals and other literature, and that the Dugan Co. and its officers had infringed the copyright of the said book by publishing substantial parts of the copyrighted work as advertisements of the wares offered for sale by the said company.

Defendants moved to dismiss the bill on the grounds that advertisements are not copyrightable, and hence advertising copy is not copyrightable, and that the copyright of a textbook or manual of instruction of a useful art, science or system does not confer upon the proprietor of the copyright the exclusive right to make use of the art, science or system explained in it.

The decision of the court, which will no doubt have a far-reaching effect on the right of merchants to insert advertisements designed and originated by others, is as follows:

"As to whether advertisements may be copyrighted there are cases both ways, but conceding, for the sake of argument, that advertisements in the forms copyrighted by the complainant would possess sufficient artistic and literary merit to be the subject of copyright, it seems to me that the second ground of objection is destructive of complainant's case.

WANTED

Job lots of any make talking machines and records.

Will buy for cash second-hand machines, shop-worn records and supplies. Correspondence strictly confidential. Address "Cash Buyer," Talking Machine World, 220 So. State Street, Chicago.

WILL BUY Edison two or four-minute records, also Victor or Columbia regular or cut-out stock records; will also buy machine stocks. Give full particulars and lowest prices. L. Paradis, P. O. Box 356, Chicago, Ill.

"Complainant has copyrighted a book and not an advertisement. Defendants have published an advertisement and not a book. The book is in the nature of a manual of instruction and is designed to teach piano dealers how to attractively advertise their wares, and contains forms, or models, or diagrams of advertisements, just as we may choose to term them.

"If complainant had published or copyrighted a manual of instructions designed to teach a piano maker how to build the instruments any person would be entitled to follow the instructions and diagrams to construct a piano. I can see no distinction between a system of instruction as to how to make a piano and a system of instruction as to how to draw an advertisement. The copyright of the book did not prevent the general public from making use of the book for the purpose for which it was designed, notwithstanding such use results in the publication of a part of the book in the form of an advertisement. In my opinion the case is on all-fours with the decision in Baker vs. Seldon, 101 U. S. 99. The motion to dismiss will be sustained."

PROSPERITY IS COMING FAST

Says Secretary Redfield of the Department of Commerce—Tariff Found Not Harmful as Foes Feared—Business Conscience Awakened and Readjustment Welcomed.

Before the Chamber of Commerce at New Haven, Conn., last Saturday night, Secretary Redfield, of the Department of Commerce, made an address in which he stated that business conditions are rapidly working toward prosperity in this country. Reminding his hearers that trade depression has been world-wide and less acute here than abroad, and that the rising tide is first felt in America, he turned to the political reforms recently made effective by legislation and their promise of abundant benefits.

"It was perfectly proper," he said, "that business men whose output was affected more or less by the new tariff should give thoughtful heed how to readjust themselves to it. Now they are saying that the readjustments are over and the new tariff at its worst is nothing like so bad as they feared, and at its best is helpful.

"Big business has often failed to see that its methods have aroused a justly popular resentment, and that many of its past purposes were impossible and intolerable in a democracy. Business conscience has now awakened, and men of might in finance are becoming men of light in the necessary readjustments that are pending.

"The sense of what is fit, the knowledge of what is due to their own honor are now so keenly alive in the business community that when the achievements of our recent discussions shall have been finally wrought into law business men will be found ready for such further work as may remain to be done."

IT CAN BE DONE.

Somebody said that it couldn't be done,

But he, with a chuckle, replied

That "maybe it couldn't," but he would be one

Who wouldn't say so till he tried.

So he buckled right in, with the trace of a grin

On his face. If he worried, he hid it.

He started to sing as he tackled the thing

That couldn't be done—and he did it.

There are thousands to tell you it cannot be done;

There are thousands to prophesy failure;

There are thousands to point out to you, one by one.

The dangers that wait to assail you;

But just buckle in with a bit of a grin,

Then take off your coat and go to it;

Just start in to sing as you tackle the thing

That "cannot be done" and you'll do it.

Cleverness may, after all, be merely an ability not to attempt the things we know we can't do.

FOR SALE OR EXCHANGE.

4,000 10-inch double face Zonophone records (brand new) in Spanish. What have you in disc talking machines and supplies for spot cash? Correspondence invited.

ROSEN'S TALKING MACHINE EXCHANGE

3 School Street

Boston, Mass.

EDISON PRAISES MACHINES.

They Aid the Working Man and Shorten Hours, Says the Great Inventor in the Course of Some Recent Interesting Remarks—Will Enable American Manufacturers to Compete Most Successfully with Europeans.

Thomas A. Edison expressed the opinion at West Orange recently that the Ford profit-sharing plan was the beginning of a new period in industrialism and was due to high efficiency with machinery. If generally adopted, he said, it would do away with labor unions.

"This great scheme of Mr. Ford's will do a world of good," he said. "When we use machines instead of humans and have a single apparatus to do the work of 250 men, then employes will enjoy real benefits. This is already true in the Ford factory in Detroit. It is a case where scientific management has rolled up enormous profits, because an article can be very cheaply manufactured on that plan.

"Mr. Ford struck the right note when he found he could sell his car for \$50 cheaper some time ago. Then, when efficiency in manufacture made it possible to complete the car for another \$50 less, he decided that his employes should reap the benefit. It is a good scheme, while the Ford people are prosperous, but I suppose if their business decreases it is only natural that the wage of the employe will decrease.

"The time is passing when human beings will be used as motors. We are to-day putting brains into machinery, and are replacing by machinery the energies of thousands of humans with only a few men to see to it that the apparatus keeps working. If other concerns were to set about to study the question of efficiency and reduce operation to the minimum cost, then employes would profit."

Improved machinery, went on Mr. Edison, would necessitate men working fewer hours, and at the same time would enable them to accomplish much more. He said that he had perfected a machine, used in the manufacture of his storage battery, which could be operated by a girl and which did the work of forty men.

Continuing, Mr. Edison said that in a few years, with the new machinery, American manufacturers would be able to undersell the Germans and other manufacturers.

"Machinery is the salvation of the American manufacturer," he said, "and will result in the United States leading the world commercially in a few years."

Mr. Edison also had a few remarks to make about the present system of education, saying that it was a remnant of the old Latin institutions and was too involved.

"What we should have," he said, "is education by demonstration."



Write today for our new catalogue giving you rock bottom prices of our specialty.

Springs for any kind of Talking Machines

No doubt you will find it interesting.



EMIL RIEDEL

Sächsische Sägen- u. Federstahlwaren-Fabrik.

Chemnitz-Gablenz, Postfach 10, Germany

The present dancing a thing to be

No other Company has gone to the expense or given the time to make their dance records so authentic as the Columbia Company.

So, we have the goods—got them right, too. Tangos, One-Steps, Hesitation Waltzes, Bostons, Turkey-Trots—every one of them in approved dance tempo, made under the personal direction of the greatest authority in this country on modern dancing—G. Hepburn Wilson, M. B., who dances while the band makes the records.

Which, being the case, we are taking two full pages in the Saturday Evening Post this week, in addition to the Columbia publicity in numerous other publications, to feature Columbia dance records.

This advertisement is all dance—and modern dance at that. These records have the real spirit that no dancing enthusiast can resist. For home dancing they are in a class by themselves—beyond the reach of serious competition.

THE SATURDAY EVENING POST February 14, 1914

Columbia

Fit Your Machine!
Pay your dealer 25 cents for our "sample" record or send the coupon to us.
Yes, no matter if it is not a Columbia. (Get our "sample" record from your dealer or send the coupon.)
If it plays regular standard disc records you can play Columbia records on it. (Get our "sample" record from your dealer or send the coupon.)

DANCE!

If you think you have danced to the best dance music that your talking machine can produce, have your dealer play any one of these—may be your dealer be able to supply them, and every Columbia dealer certainly has them ready now.

TANGOS

- A. 1463 (10-cms) **GOOD FELLOW** (Six Men Band) Played by the Municipal Band of Boston.
- 65c. **TANGOLETTE** (Six Men Band) Played by the Municipal Band of Boston.
- A. 1464 (10-cms) **EL CHICHON** Played by the Municipal Band of Boston.
- 65c. **AUXILIO** Played by the Municipal Band of Boston.

The "sample" record is the property of the Columbia Graphophone Co. and is loaned to you for the purpose of this advertisement. It is not to be resold or otherwise disposed of.

ONE-STEPS and TURKEY TROTS

- A. 1307 (10-cms) **TOO MUCH MUSTARD** (Five Men Band) Played by the Municipal Band of Boston.
- 65c. **ON THE MISSISSIPPI** Played by Prince's Band.
- A. 1465 (10-cms) **SOME SMOKE** (Six Men Band) Played by Prince's Band.
- 65c. **LEG OF MUTTON** (Six Men Band) Played by Prince's Band.

BOSTON and HESITATION WALTZES

- A. 1466 (10-cms) **THE POLKA** (Six Men Band) Played by Prince's Band.
- 65c. **THE POLKA** (Six Men Band) Played by Prince's Band.
- A. 1467 (10-cms) **ORCHARD WALTZ** Played by Prince's Band.
- 65c. **THE POLKA** (Six Men Band) Played by Prince's Band.
- A. 1468 (10-cms) **RESPONSE TO AMOURUSE** (Five Men Band) Played by Prince's Band.
- 65c. **LOVE'S TEARS** (Five Men Band) Played by Prince's Band.

Columbia Graphophone Co.
428 West 42nd St., N.Y.

25 Cents enclosed

Send me your special sample record with "Good-Night, Little Girl, Good Night" on one side and the musical experiment on the other. And give me the name of the nearest Columbia dealer.

I own a machine.

NAME

ADDRESS

Fit your
even if it is not a



Columbia Graphophone

Woolworth Building

g craze is too good e passed by

And the demand for records of this kind is actually shouting.

If you are not yet sharing in the Columbia dance record dividends, step around to the handiest Columbia dealer. Ask him to play Columbia Record A-1458. When you have heard it, just ponder over the fact that that's the kind of dance music he is selling to his customers—and *yours*, too, don't forget that—for *65 cents*.

THE SATURDAY EVENING POST

Records

65 Cents

each is the price of a full thousand ten-inch Columbia Double-Disc Records—quality, tone, reproduction and durability unexcelled and so guaranteed to you. Other Columbia records all the way up to \$7.50.

Now get that new "sample" record for 25 cents from your dealer—or send us that coupon with 25 cents in coin or stamps, and we will send it to you ourselves. It proves what at best we can only print here.



Columbia Graphophone Co.
New York
Box 428, Woolworth Bldg., 365-367 Nassau Ave.
Manufacturers of the Gramophone



The Columbia Gramophone "Favorite" \$50
The standard of the talking-machine market, equipped like all Columbia Gramophones, with the exclusive Columbia concentrated "horns" which have taken the place of the old double-horn type. Other Columbia Gramophones from \$10 to \$200. Good of course they will all play records of any standard make.

alking machine
Columbia Gramophone

VERNON CASTLE
originator of "Castle Walk" and many other modern dances, endorses Columbia records.

Columbia Graphophone Co.
Woolworth Building, New York City

Gentlemen:—

I want to congratulate you on the excellent dance records you have recently issued; they are the best I have heard. I am using a Columbia Grand Gramophone and Columbia Records at Castle House where they are attracting extraordinary attention. The records are played in perfect dance time and are frequently encored by our patrons.

Vernon Castle

phone Company

g, New York



NEW EXPRESS RATES OF MUCH INTEREST TO TRADE

Will Prove of Benefit to Talking Machine Jobbers and Dealers Throughout the Country—
Schedule of New Rates as They Apply Between the Principal Cities of the Country.

The new express rates, ordered by the Interstate Commerce Commission, and which went into effect throughout the country on February 1, and particularly interesting to the talking machine jobbers and dealers as affording a means for facilitating rapid shipments and deliveries and much reduced expense. The express companies take machines and other packages much heavier than the

parcel post limit, and in addition provides a receipt that takes the form of free insurance. The sweeping reduction in the express rates is indicated by the accompanying tables prepared by the express companies, and showing charges of specified weights between two prominent cities of the country, the rates being based on fixed distances instead of the mileage plan.

Between New York and	5 lbs.		10 lbs.		20 lbs.	
	Insurance up to Fifty Dollars					
	New Rates	Old Rates	New Rates	Old Rates	New Rates	Old Rates
Chicago	.31	.60	.42	.75	.64	1.00
St. Louis	.32	.65	.44	.80	.68	1.10
New Orleans	.41	.75	.63	1.10	1.06	1.40
Dallas	.45	.75	.70	1.15	1.20	1.65
Denver	.47	.80	.75	1.25	1.30	2.00
San Francisco	.71	.80	1.22	1.50	2.24	2.85

Between Philadelphia and	5 lbs.		10 lbs.		20 lbs.	
	Insurance up to Fifty Dollars					
	New Rates	Old Rates	New Rates	Old Rates	New Rates	Old Rates
Portland, Me.	.27	.50	.34	.60	.48	.75
Buffalo	.27	.40	.34	.50	.48	.60
Cincinnati	.29	.50	.38	.60	.56	.75
Milwaukee	.31	.60	.43	.75	.66	1.00
Mobile	.38	.75	.55	1.00	.91	1.30
Seattle	.67	.80	1.14	1.50	2.09	2.85

Between Atlanta and	5 lbs.		10 lbs.		20 lbs.	
	Insurance up to Fifty Dollars					
	New Rates	Old Rates	New Rates	Old Rates	New Rates	Old Rates
Jacksonville	.28	.60	.35	.75	.51	1.00
Memphis	.30	.60	.40	.75	.60	1.00
Cincinnati	.31	.60	.41	.75	.63	1.00
Richmond	.31	.60	.43	.75	.66	1.00
Baltimore	.33	.70	.46	.90	.72	1.20
New York	.34	.70	.48	1.00	.77	1.25

Between St. Louis and	5 lbs.		10 lbs.		20 lbs.	
	Insurance up to Fifty Dollars					
	New Rates	Old Rates	New Rates	Old Rates	New Rates	Old Rates
Detroit	.28	.55	.36	.70	.52	.85
Birmingham	.30	.65	.39	.80	.59	1.10
St. Paul	.30	.65	.41	.80	.62	1.10
Philadelphia	.32	.65	.43	.80	.67	1.10
San Antonio	.40	.75	.59	1.00	.99	1.30
Los Angeles	.62	.80	1.05	1.40	1.90	2.50

Between Chicago and	5 lbs.		10 lbs.		20 lbs.	
	Insurance up to Fifty Dollars					
	New Rates	Old Rates	New Rates	Old Rates	New Rates	Old Rates
Boston	.31	.60	.43	.75	.65	1.00
Oklahoma City	.36	.70	.52	1.00	.85	1.25
Jacksonville	.36	.75	.52	1.10	.85	1.40
Galveston	.39	.75	.59	1.15	.98	1.65
Salt Lake	.52	.80	.84	1.25	1.48	2.00
Portland, Ore.	.63	.80	1.06	1.40	1.93	2.75

Between San Francisco and	5 lbs.		10 lbs.		20 lbs.	
	Insurance up to Fifty Dollars					
	New Rates	Old Rates	New Rates	Old Rates	New Rates	Old Rates
Houston	.63	.80	1.06	1.40	1.93	2.30
Minneapolis	.63	.80	1.07	1.40	1.94	2.75
Chicago	.65	.80	1.11	1.40	2.02	2.75
Cleveland	.67	.80	1.14	1.40	2.09	2.75
Washington	.70	.80	1.21	1.50	2.22	2.85
Boston	.71	.80	1.23	1.50	2.26	2.85

TALKING MACHINE EXPORTS.

The Figures for December Presented—Reports Show Falling Off for the Month.

(Special to The Talking Machine World.)

WASHINGTON, D. C., February 9.—In the summary of the exports and imports of the commerce of the United States for the month of December (the latest period for which it has been compiled), which has just been issued by the Bureau of Statistics of the Department of Commerce and Labor, the following interesting figures relating to talking machines and supplies are set forth:

The total exports of talking machines, records and supplies for December, 1912, amounted to \$232,900, as compared with \$236,426 for the same month of the previous year. The twelve months'

exportation of talking machines, records and supplies amounted to \$2,792,667.

LEIPZIG FAIR OPENS MARCH 2.

(Special to The Talking Machine World.)

LONDON, ENG., February 3.—On March 2 the Leipzig Fair commences and, as usual, will continue for one week; that is, the commercial side of it. The Leipzig City Council has been advertising the business attractions of the Fair pretty thoroughly in the leading London newspapers, and all indications point to a record number of visitors. Gramophone men usually attend the spring gathering in large numbers, but at the time of writing, while most of them speak of the probability of going over, few will commit themselves to a definite decision so many weeks in advance.

AN ODDITY IN ENVELOPES.

The Columbia Graphophone Co. received recently an envelope addressed in a truly distinctive

and unique fashion. Every possible detail, including patent numbers, was shown on this envelope, which is presented herewith, and any danger of miscarriage was apparently eliminated.

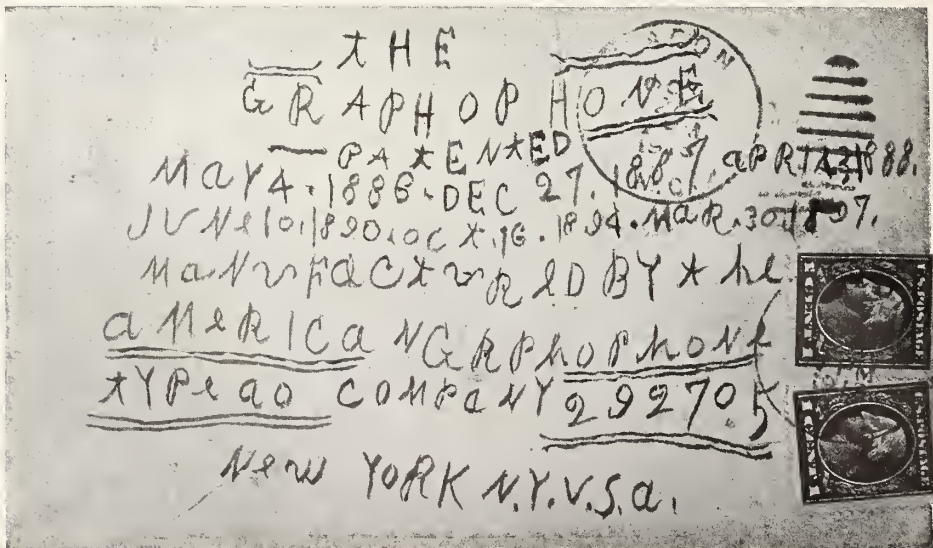

"HEARING" TYPE BY MACHINE.

New Invention for Benefit of the Blind, That Causes Different Printed Letters to Indicate Their Character by Sound.

A blind man may some time be able to read the daily newspapers, books or all printed matter with no aid except that of a machine. Such a machine has now been devised, but it is still far from perfect. Posters furnish about the only reading that can be done with it now.

What the apparatus does is to sound musical notes or chords in the blind man's ear for each printed letter. With experience the blind man will be able to tell the letter each combination of notes is intended to represent.

The inventor of this machine is a London scientist. Over a year ago he perfected an instrument that would enable a blind man to detect the source of any light near him—to find the window of a room, for instance. A box that looked something like a camera was held in the hands of the blind man and wires connected the box with a telephone receiver at the blind man's ear.

A selenium unit in the box detected any light and sent a current to the telephone receiver, thus making a sound in his ear. The blind man could point his box or camera in any direction. When it was pointed at light the telephone receiver vibrated, the loudness of the noise being dependent on the strength of the light.

The new device is a development of this box—or optophone, as it is called. Words in large type—on a poster, for instance—are passed in front of the new instrument. A strong light is thrown on the type, part of this light being reflected back from the white paper and part of it not being reflected—where the rays strike the black ink. The returning rays are detected by a checkerboard group of selenium cells. Each of these checkerboard cells will cause a musical note to sound in the telephone receiver at the blind man's ear, and each cell has its own individual musical note.

When the letter M is passed in front of the instrument, for instance, there is first a crash of a whole scale of tones, as the upright line at the left comes along; then, as the slanting middle lines pass before the instrument, the notes first run down the scale and then up the scale; and then the right-hand upright line causes another crash of many notes. The blind man quickly learns that this combination of sounds means M.

The inventor hopes it will be possible to perfect his apparatus eventually so that it can be used on ordinary type. On the face of it, the apparatus needs only refinement to enable blind men to read newspapers; but it is extremely difficult to obtain that refinement.

The Kelley Music Co., Jersey City, N. J., is a recent addition to Columbia agencies.

STROH VIOLS

VIOLIN, VIOLA, ETC.

The mellow and matured tone of these instruments, which are constructed largely of aluminum, yet possess none of the characteristics of the gramophone or wind instrument, is only one of its many points which are fully set out in an illustrated booklet which will be mailed free on request to the sole makers.



String Fiddle

GEO. EVANS & CO. 94 Albany St. London, Eng.

OR

in U. S. A. to their sole representatives

OLIVER DITSON CO.

150 Tremont Street BOSTON
NEW YORK and PHILADELPHIA

GRAND OPERA AND THE TALKING MACHINE.

The Importance of Their Relations and the Influence Exercised in the Matter of Public Taste Set Forth in Article Written for The Voice of the Victor by Albert Grau, Brother of the Famous Impresario—Interesting Reminiscences of Early Opera.

It does not seem so very long ago that grand opera was regarded as the most precarious line of endeavor with which men of nerve and capital could tempt fate, and even so intrepid an impresario as Colonel Mapleson predicted that the ultimate destination of his kind was either the county jail or the poorhouse.

But Colonel Mapleson and his colleagues, such as the Strakesches, Maretzek and the indefatigable Henry E. Abbey, all of whom died penniless, were unfortunate in that their period of activity antedated the advent of a scientific era in which, as a result of the amazing evolution of the talking machine, the scores of masters, and the world's greatest singers have been brought into our homes, and this has gradually created a nation of opera-goers, so that the spectacle of three majestic opera houses opening simultaneously in New York City, which as recently as ten years ago would have meant sure disaster, may now be viewed with complacency by impresarios, artists and public.

Even during the régime of Maurice Grau, ending in 1904, the Metropolitan Opera House had established the first operatic dividends known to American musical history, and this impresario was quick to observe that a new musical public was being created. Crowded balconies and galleries were solving grand opera's difficult problems, and the day when the works of Wagner, Verdi, Gounod, Puccini and their colleagues could attract only the social set was already passing.

But the talking machine, up to the time of Mr. Grau's retirement from the operatic field, was yet regarded as a mere toy. From 1904 to the year of 1913 were nine years of persistent musical uplift, in which the Victor Co.'s extraordinary enterprise had caused the musical map to change from coast to coast. It mattered not whether it was Caruso,

Tamagno or any of the famous singers who are paid thousands a night, they all capitulated to the inducements held out to them. But let no man doubt that this was greatly due to the astonishing development of the Victor, and not solely to the financial benefits. Moreover, there is no record of any protest in recent years on the part of the impresarios of grand opera, all of whom were brought to realize that the influence of the Victor was being felt in the box offices. This is so true that although the world's greatest singers were now adding to their annual income prodigious sums of money, while their artistry was being perpetuated scientifically, their compensation has been constantly growing larger, in the opera houses, while a third source of income, also greatly due to the Victor, has resulted from the tremendous demand for their services for concert tours, song recitals and festivals galore all over the country.

I can remember when there were not over thirty cities where a famous diva could attract a paying audience, and even ten years ago not more than five or six musical celebrities could procure sufficient bookings to justify a tour. To-day there are as many as sixty well-known vocal and instrumental soloists who can attract an audience representing anywhere between \$1,500 and \$6,000 at each appearance.

It is a fact that the demand to hear and see the famous musical stars by a new and increasing public is so great that while the distinctly dramatic or theatrical business all over the country has had an awful slump, the prosperity in the musical field is everywhere conceded. Mme. Schumann-Heink has attracted audiences in cities of about 20,000 population representing from \$2,500 to \$4,000, while in the larger cities the larger sum is an ordinary achievement. Yet this same Schumann-

Heink came hither from Berlin under my brother's direction at a weekly honorarium of \$250. If you would ask the great German contralto her opinion, she will tell you that the Victor has accomplished more to make the nation musical than all other influences combined.

When it was announced that opera in the language of the nation was to become a permanent attraction in the theater endowed by New York's multimillionaires, this writer ventured to predict that the outcome would be successful from the outset, and now when the pessimists are confronted with the spectacle of capacity audiences night after night and week after week, the fear is expressed that with the advent of the regular opera season at the Metropolitan Opera House and the inauguration of a third régime—that of Oscar Hammerstein—the gold-laden box office of the Century Opera House must show the effects instantaneously; but it will be found that New York with its 6,000,000 souls can, and will, provide a public for all three, provided that the artistic offerings are wholly worthy, and surely there is nothing to indicate a reaction in the near future in the neighborhood of Central Park West, where the advance subscriptions are already assuring prosperity for months to come.

The Messrs. Aborn know from experience that popular-priced opera is a necessity in our larger cities, and they have publicly acknowledged that this is principally due to the thousands of new music lovers who, having heard in their own homes the voices of celebrated singers and the melodies over which they have raved, now flock to the opera house or theater where they are held fast, and this is a condition which explains why in the heat of summer, when the playhouses usually are closed, the Messrs. Aborn have prospered in a half dozen cities simultaneously.

But even now the influence of the Victor is in the infant stage. The Victor Co. is not resting on its laurels; one may see evidences at every turn of expansion and productivity and an effort to embrace newer fields in which its conquest a few years ago would have been difficult to accomplish.



To T.M. the King and Queen of Spain



To H.M. the King of Sweden



To H.H. the Khedive of Egypt



To H.M. the King of Italy



To H.M. the Shah of Persia



By Appointment To H.M. Queen Alexandra

"His Master's Voice"
—the trade-mark that is recognised throughout the world as the
Hall-mark of Quality

AUSTRIA: Oesterr. Gramophon-Gesellschaft, m. b. H., 8, Krugerstrasse, Vienna.
BELGIUM: Cie. Française du Gramophone, 51, Avenue de la Porte de Hal, Brussels.
DENMARK: Skandinavisk Gramophon-Aktieselskab, Frihavnens, Copenhagen.
FRANCE: Cie. Française du Gramophone, 115 Boulevard Richard Lenoir, Place de la République, Paris.
GERMANY: Deutsche Gramophon-Aktiengesellschaft, 35, Ritterstrasse, Berlin, S42.
HOLLAND: American Import Co., 22a, Amsterdam, Veerkade, The Hague.
HUNGARY: The Gramophone Co., Ltd., IV, Kossuth Lajos-Utca 8, Budapest.
SPAIN: Cia. Francesa del Gramophone, 56, Balmes, Barcelona.
SWEDEN: Skandinaviska Gramophon-Aktiebolaget, 52, Appelbergsgatan, Stockholm.

RUSSIA: The Gramophone Co., Ltd., 45, Nevsky Prospect, St. Petersburg; 9, Golovinsky Prospect, Tiflis; 30, Novis Svit, Warsaw.
EGYPT: The Gramophone Co., Ltd., 13, Rue Stamboul, Alexandria; Rue Mousky, Cairo.
EAST AFRICA: Bayley & Co., 8 Beira, Lourenço Marques.
SOUTH AFRICA: Darter & Sons, Adderley St., Cape Town; Mackay Bros., Rissik Street, Johannesburg; Mackay Bros & McMahon, 443, West Street, Durban; Ivan H. Haarburger, Maitland St., Bloemfontein.
INDIA: The Gramophone Co., Ltd., 139, Balliaghatta Road, Calcutta; 7, Bell Lane, Fort, Bombay.
AUSTRALIA: The Gramophone Co., Ltd., Hoffnungs Chambers, Pitt Street, Sydney.
GREAT BRITAIN: The Gramophone Co., Ltd., 21, City Road, London, E.C.

Great Britain:
The Gramophone Company Ltd
21 City Road London EC



UP-TO-THE-MINUTE "PURE ADVERTISING" LABORATORY.

The Interesting Story of the Edward C. Plume Co., a House Which Creates Strong, Ethical, Convincing Advertising Matter for Talker Merchants and Those in Other Lines of Trade—Some Excellent Views of the Model Establishment in Chicago and Its Trained Staff.

(Special to The Talking Machine World.)

CHICAGO, ILL., February 10.—The World takes genuine pleasure in presenting views of the general office, copy and art rooms of the Edward C. Plume Co., of this city. The reason for the "pleasure" is that the company is doing a work thoroughly in

slides for the use of the merchant in exploiting his product in moving picture theaters. Reproductions of some of the advertisements put out by the Edward C. Plume Co. have already appeared in The Music Trade Review. The series is a remarkable one in that the announcements while forceful,

pany's excellent and result productive advertising service.

The offices, however, are splendidly equipped for the great educational campaign which Mr. Plume has under way, and which means so much for the uplift of advertising.

Those members of the trade who have already made use of the Plume Co.'s advertising service are enthusiastic regarding the originality of the ideas embodied therein and the character of the copy, as well as of the results produced thereby, in the line of prospects and sales. It is the sort of advertising that stands the test.



General Offices of the Edward C. Plume Co., Chicago.

accord with the private convictions and public propaganda of The World along the lines of "pure advertising."

The Edward C. Plume Co., as the readers of The World well know, was founded several years ago by E. C. Plume, who was for a number of years the Western wholesale manager for the Columbia Graphophone Co., and in that capacity came in contact with many talking machine and

convincing and calculated to get results, are absolutely ethical and are such as to exalt the standard of the individual merchant and the trade in the mind of the public.

The first of the three views here presented shows the company's general offices, which occupy a large part of the third floor of 417-421 South Dearborn street and the entire street frontage. Mr. Plume's office is in the front on the right hand side. Mr.

NEW VICTOR DANCE RECORDS.

Interesting List Issued to the Trade Recently by the New York Talking Machine Co.

The New York Talking Machine Co., 81 Chambers street, New York, the prominent Victor distributor, sent out to its clientele a fortnight since a special list of new Victor dance records which was compiled after due consideration. These rec-



The Laboratory.

piano dealers and naturally is conversant with conditions in this trade. In the period between his resignation from the Columbia Co. and the founding of his present business Mr. Plume had associated with him B. L. Kelley in an advertising concern, and his experience in that line opened his eyes to the wide field for the right kind of advertising matter in the talking machine and other lines of trade. The Edward C. Plume Co. was established with ample financial backing, with Mr. Plume as president and Mr. Kelley as assistant treasurer and secretary.

While the activities of the company along advertising lines run in various channels, it features high grade newspaper advertising copy handsomely illustrated, artistic mailing folders and advertising

Kelley can be seen in his office at the right in the rear, and to the left is shown the office of J. L. Fraser, sales manager. The copy and art room is next to Mr. Plume's office, but is not shown in the general view. In the second view Mr. Plume is seen in his private office in consultation with W. F. Schramm, the advertising manager. We cannot just recall whether this picture was taken at the time when they were discussing the securing of the services of "Penny" Ross, in devising a series of Mamma's Angel Child folders, or whether it was when the Plume Co. bought out a large Cincinnati advertising service concern. After careful reflection, however, we are inclined to think that it shows the presidential and copy-creating brains working on an important extension of the com-



The President's Private Office.

ords were listed on a specially printed sheet, and labeled "The New York Talking Machine Co.'s Extra Special."

The company had expected that the list would be favorably received by its dealers but were unprepared for the remarkably large number of orders that were received within two days after the list was mailed. Many dealers ordered 100 apiece of all the records listed, and some of the company's patrons used the telephone and telegraph to place their orders at the earliest possible moment. The success of the list was a significant indication of the popularity of Victor dance records, and an impressive endorsement of the live-wire methods of the New York Talking Machine Co.

A REMARKABLE EDISON ADVERTISEMENT IN CHICAGO.

TALKER MEN MEET IN LOS ANGELES.

Grand Opera Continued in Chicago

Chicago's official operatic season has closed—but you may still hear Grand Opera!

Special arrangements have been made by which Chicago opera lovers may continue to hear their favorites.

Selected programs of popular operatic numbers—sung by the most renowned opera stars, will be presented every afternoon at the Edison Shop, between 3:00 and 4:00 P. M. This is in addition to the regular concerts which continue as before—daily from 11:30 A. M. to 5:00 P. M.

Call today and hear the gems of opera sung by the world's greatest artists—reproduced with all the purity of sound and unblemished art of the original. No charge for admission.

Call any afternoon and hear the superb New Edison—in which the inventor has finally overcome all defects and difficulties and has attained the great goal toward which he has striven for years—Perfect Reproduction of Sound.

In Mr. Edison's own words, "Real Music at Last."

Hear It!

Call and hear this superb new instrument—the supreme triumph of Thomas A. Edison. No charge for seats in concert room.

Hear the wonderful new Edison records—scores of new records just received. Or bring along some of your favorite disc records (foreign or domestic records of any make) and hear them played on the Edison as you have never heard them played before.

Concerts Daily From 11:30 A. M. to 5:00 P. M.

In the Beautiful Concert Hall at the Edison Shop. There is no charge for these concerts and no obligations or requests to buy. We are eager for everyone in Chicago to hear the New Edison if merely to tell others of the wonderful music.

On write for description booklet of prices and outfit.

The New Edison

Is Indeed Thomas A. Edison's Supreme Triumph.

The new Diamond Stylus Reproducer—the New Edison Disc Records—the New Edison Motor and the concealed sound conveyor have all been worked out to absolute perfection.

The New Edison Records, with music on both sides, are so wonderfully superior to anything that has ever been heard before as the new instrument is superior to all others.

These new records are made of an entirely new material and do not wear or scratch. They are not needed to scratch and wear them out. The Diamond Stylus Reproducer with the highly polished diamond point will reproduce the Edison records thousands of times and the last reproduction will be as perfect as the first one.

With Mr. Edison's new method it is possible to mold into these records every fine shading and subtle distinction of an artist's voice. Call today and hear.

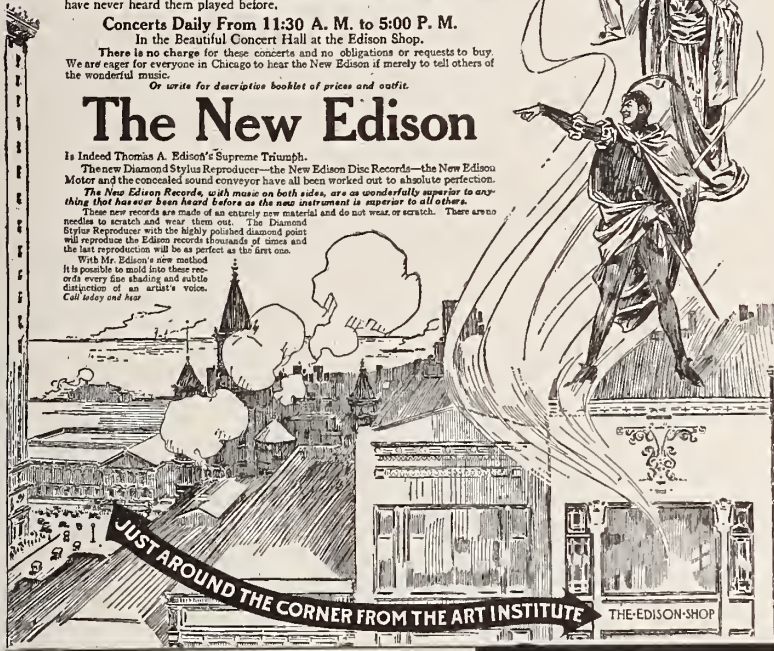

Edison Concerts now being given in the following cities:

- Albany, Ill.—Columbia Press Co.
Alton, Ill.—Columbia Press Co.
Baltimore, Md.—Columbia Press Co.
Birmingham, Ala.—Columbia Press Co.
Boston, Mass.—Columbia Press Co.
Buffalo, N. Y.—Columbia Press Co.
Chicago, Ill.—Columbia Press Co.
Cincinnati, Ohio.—Columbia Press Co.
Cleveland, Ohio.—Columbia Press Co.
Columbus, Ohio.—Columbia Press Co.
Dallas, Tex.—Columbia Press Co.
Dayton, Ohio.—Columbia Press Co.
Denver, Colo.—Columbia Press Co.
Detroit, Mich.—Columbia Press Co.
Houston, Tex.—Columbia Press Co.
Indianapolis, Ind.—Columbia Press Co.
Jacksonville, Fla.—Columbia Press Co.
Kansas City, Mo.—Columbia Press Co.
Los Angeles, Cal.—Columbia Press Co.
Louisville, Ky.—Columbia Press Co.
Memphis, Tenn.—Columbia Press Co.
Milwaukee, Wis.—Columbia Press Co.
Minneapolis, Minn.—Columbia Press Co.
New York, N. Y.—Columbia Press Co.
Philadelphia, Pa.—Columbia Press Co.
Pittsburgh, Pa.—Columbia Press Co.
Portland, Ore.—Columbia Press Co.
Rochester, N. Y.—Columbia Press Co.
St. Louis, Mo.—Columbia Press Co.
St. Paul, Minn.—Columbia Press Co.
San Francisco, Cal.—Columbia Press Co.
Seattle, Wash.—Columbia Press Co.
Syracuse, N. Y.—Columbia Press Co.
Tampa, Fla.—Columbia Press Co.
Washington, D. C.—Columbia Press Co.
Wichita, Kan.—Columbia Press Co.

The Edison Shop

(The Phonograph Co., Proprietors) 229 Wabash Avenue, Chicago, Ill.

One of the most striking and undoubtedly one of the best advertisements from the viewpoint of direct results appeared in the Chicago Tribune Sunday of last week. It was inserted by the Phonograph Co., the prominent Edison distributors in Chicago, and while more directly exploitive of the Edison shop, the Phonograph Co.'s retail department is of intense interest to Edison dealers everywhere to whom it will no doubt appeal as a model advertisement of Edison goods. It is one of a series of remarkable announcements which Manager C. E. Goodwin has been running. It occupied a space equal to five full columns, or five-sevenths of a page. A reproduction of the advertisement in miniature is printed herewith.

One of the most noteworthy features in connection with the country-wide campaign being conducted in the interests of the Edison disc phonographs has been the striking originality and forcefulness of the advertising.

Southern California Talking Machine Men's Association Holds Bi-Monthly Meeting and Banquet in That City—Interesting Papers Read on Live Subjects.

(Special to The Talking Machine World.) LOS ANGELES, CAL., February 7.—The bi-monthly banquet and meeting of the Southern California Talking Machine Men's Association, was held at the usual place, the Hollenbeck Hotel, January 29. After the dinner a most interesting talk was given upon the "Use and Results of the Victor in the Public Schools," by Miss K. Stone, musical supervisor of the Los Angeles Public School. Also a paper was prepared by Mrs. Sibley G. Pease upon the "Local Musicians and Composers." A brief speech was given by the president of the association Sibley G. Pease, then followed the regular routine of business and a general discussion of matters relating to the talking machine trade.

IT HITS THE MARK.

That's What Merchants Are Saying About the "CL" H. P. Nelson Player-Piano.

(Special to The Talking Machine World.) CHICAGO, ILL., February 9.—"In all my experience I never saw anything that seems to be designed so completely to satisfy the present demand as the Style "CL" H. P. Nelson player-piano." This is the burden of a letter received to-day from a dealer by the H. P. Nelson Co. "It gives me something to go after big popular trade, and after a careful examination I know that it is going to be a winner, because it is built right and is going to be a continual prospect producer. The sample is already spoken for." Then followed an order that demonstrated that the dealer was building on the faith that was in him.

Similar letters are being received from all parts of the country. H. P. Nelson is evidently on the eve of another of his remarkable successes in piano and player production.

The new wholesale salesrooms of the H. P. Nelson Co. are the scene of considerable activity these days, and a half a dozen automobiles are kept busy bringing dealers out to the factory from the downtown district. A hundred and fifty pianos are shown on the floor, presenting the H. P. Nelson styles in all of the various woods.

One that is attracting a big share of the attention of the visitors, is the new Style 106 Nelson piano, an exceptionally attractive instrument that is drawn along simple lines, and which is equally good to look upon in either mahogany, oak or walnut. A number of other styles are also being brought through the factory.

Orville Harrold, the celebrated tenor, whose records in the Columbia library have scored a pronounced success, has joined the Century Opera Co., where he will be presented in important parts. Mr. Harrold will be the third well-known male singer in the Century Opera Co. whose records are in the Columbia library; Morgan Kingston and Walter Wheatley also being well represented.

CONSISTENT PUBLICITY PAYS.

Southern progressiveness is well exemplified in the excellent newspaper advertising used the year round by the Tampa Hardware Co., Tampa, Fla., the prominent Columbia distributor. This enter-

prising house is conducting a campaign in Tampa newspapers which is resulting in the closing of a splendid business both in machines and records. Large space is used, and appropriate illustrations together with convincing selling talks make this advertising distinctive and sales productive.

Schafford Album Co. now at 27-29 Walker Street New York

ORDER COUPON

If you have never seen a Schafford Record Album, send this coupon with \$1 and you will receive a 12" Album, together with wholesale prices on both 10" and 12" Albums.

Name
Address

Your Album orders made us secure larger quarters, where, with more space and additional modern equipment, we are in even a better position to make talking machine record Albums. More quality at the same price will be the keynote ever living to our slogan of "Greatest Album value in America."

Schafford Album Co.

27-29 Walker St.

NEW YORK

A DEALER WHO GETS RESULTS.

George J. Lenth, Although Located in a Town of Only 1,300 in Iowa Orders Full Carload of Edison Disc Machines and Records and Gets Right After the Business—Shipment Well Advertised En Route to His Town.

When a phonograph dealer in a town of 1,300 population orders a solid car-load of machines, in the parlance of the street, he is certainly "going some." This was the splendid record achieved by Geo. J. Lenth, a hustling and progressive Edison disc dealer in Elkader, Clayton County, Ia. It is a safe bet that many talking machine dealers in the East have never heard of Elkader, Ia., but there is no doubt that Elkader will be well acquainted with the Edison phonograph before Mr. Lenth gets through.

The solid carload of Edison disc phonographs and records intended for Mr. Lenth left the Edison factories on January 21, and in order that cities and towns along the route of shipment could be fully acquainted with Mr. Lenth's enterprise and energy, the following large-sized sign was placed on the side of the car: "Solid carload of the wonderful new Edison diamond disc phonographs, bought by George J. Lenth, Elkader, Ia., population 1,300." The mere fact of the carload shipment leaving the Edison plant was nothing unusual, but the 1,300 population was the impressive part of the sign.

It is understood that Mr. Lenth, who is a firm believer in the value of personal solicitation, has also arranged for the giving of several concerts in the Elkader churches and places of amusement to feature the Edison disc phonograph. It is safe to say that if these concerts meet with the same degree of success that Mr. Lenth's personal efforts evidently have, there will be another carload of Edison phonographs and records very shortly.

ORIGINAL PUBLICITY PAYS.

How Brodie & Bro., of Waverly, Ia., Are Bringing the Victrola to the Attention of the People of That City with Excellent Results.

(Special to The Talking Machine World.)

WAVERLY, IA., February 9.—Taking advantage of all opportunities offered from a publicity standpoint is well illustrated in the postcards and circulars being sent out to their clientele by A. A. Brodie & Bro., of this city, the hustling representatives of the Victor Talking Machine Co. in this territory. These postcards and circulars are the subject of general comment and attention, as they are decidedly original in their design.

The purpose of this literature was to illustrate the extent of the company's business, as the scene presented was that of a wagon-load of Victrolas

being taken through the streets of Waverly, en route to the store of A. A. Brodie & Bro. The wagon was snapped in front of the store, and underneath the picture was printed: "Your Victrola is in this load. Come on in." It is pleasing to note that this up-to-the-minute publicity produced excellent results commensurate with the distinctiveness of the idea.

AID TO INCREASED RECORD SALES.

Special Cover to Hold Standard Record Catalogs Just Issued by the New York Post Card Co. and Meets with Immediate Demand.

"We are now ready to announce to the talking machine dealers throughout the country, something new that we are certain will prove a boom to their record sales," stated George Bates, of the New York Postcard Album Manufacturing Co., 23 Lispenard street, New York, manufacturers of talking machine record albums.

"Our latest product consists of a handsome flexible cover arranged to hold the Victor or Columbia six-months' record catalog, and one monthly supplement if desired. This cover is artistic in its appearance, being bound in mahogany colored imitation leather and lined with black silk cloth. The catalogs are placed in the cover by means of an adjustable cord which permits of easy and quick insertion. The cover being flexible, is convenient to a degree, forming a permanent reminder of the record catalog inclosed, and the dealer's name thereon will naturally mean increased record sales.

"In my travels around the country, many dealers have often expressed the thought that the handsome record catalogs issued regularly by the companies are not properly handled by their clients. As the catalogs are only made of paper, it is but natural that they should soon tear or curl up, and not presenting the artistic appearance so desirable in a music room, are soon hidden out of sight. These dealers felt certain that something should be designed that would permit of the inclosing of the record catalog in an attractive flexible cover, which the talking machine owner would always keep near at hand, instead of placing it in some drawer or out of the way place, as is the case with the present paper-covered catalog after it has been in use a short while.

"Working along these lines we experimented for some time until we arrived at the decision that a catalog cover that would be really successful must not be bulky or ugly, but contain only two strings, one for the regular catalog and the other for one monthly supplement if desired. Our new cover is the result of our experimenting.

"We have arranged to print the dealer's name on the face of the cover in gilt in lots of 100 and more, thereby making the cover a permanent ad-

vertisement when placed in the hands of his clients. The price of the cover has been placed so low that dealers will find it profitable to give one away with the first record catalog given to a client, or if they desire they may charge a nominal sum for the cover either on the first distribution or when the customer desires more than one cover. These are all details which the dealer can arrange in the way which will give him the most profit and advantageous publicity. Advance orders indicate the success of our new cover, as it forms a useful souvenir and a permanent advertisement."

WHEN "NEXT" IS A PLEASANT WORD.

Barbers and Bootblacks Appreciating Value of the Talking Machine in Keeping Their Overflow of Customers in Good Humor.

The Italian has long been a strong devotee to the talking machine as a means for his own entertainment and as affording him an opportunity to listen to his favorite operas in his home, no matter how humble, and at his own convenience. He has also discovered that the talking machine is an excellent business partner under certain conditions, and recently in many sections of the country "talkers" with a plentiful supply of records have been found in barber shops and bootblack parlors. The man who is being shaved or having his boots blacked or is waiting his turn to receive the attention of the "artist" in charge is not likely to lose patience over the delay if he is able to enjoy music during the wait.

SELECTED AS OFFICIAL MACHINE.

Dictaphone Installed in Offices of Panama-Pacific International Exposition for Use of Officials in Various Departments—Many Machines Required.

(Special to The Talking Machine World.)

SAN FRANCISCO, CAL., February 9.—As announced in The World two months ago, the Dictaphone has been installed as the official dictating machine of the Panama-Pacific International Exposition, and many of these machines are now in use in the various departments, we understand.

It is planned to secure for permanent record speeches delivered by Commissioners and distinguished visitors to the Exposition. This will be done by having them dictate their speeches or messages on a cylinder, which will be kept, and later made a part of the Columbia Graphophone Co.'s exhibit at the Exposition.

W. S. Gray, Pacific Coast manager of the Columbia Graphophone Co., declares that the exhibit of graphophone and dictaphones in the Palace of Liberal Arts, will be a remarkable one.

JOBBERs intending to IMPORT
Talking Machines, Motors,
Disc-Records should visit

OUR SHOW ROOMS AT THE **LEIPZIG FAIR** AND INSPECT OUR NEW MODELS

POLYPHON - MUSIKWERKE, A.-G.

Representative: A. B. NEWCOMBE, New York, 71 West 23rd St.

Works: LEIPZIG-WAHREN 41

Show Rooms: LEIPZIG, PETERS STR. 281



Columbia dealers' record business during the first forty-five days of 1914 has been twice any previous sales record. Did you share in this?



(Write for "Music Money," a book "full of meat" for those dealers interested in quick and frequent turnover of capital.)

Columbia Graphophone Company
Woolworth Building, New York

DEMAND FOR DANCING RECORDS ALSO HITS DETROIT.

Incident in Store of Columbia Co. Indicates That the Craze Hits All Classes—Machine Sales Keep Up Well—Salesmen Enrolled in Efficiency Course of Board of Commerce—Piano Houses Find Profit in Talking Machines—Other Interesting News of Past Month.

(Special to The Talking Machine World.)

DETROIT, MICH., February 9.—The correspondent of the Talking Machine World stopped and took a second look as he entered the Columbia branch store the other day for his usual confab with Manager K. M. Johns. Skipping about the floor with all the abandon of a primary grade school girl, was a fashionably attired man, apparently having the time of his life, but nevertheless, as sober-faced as a magistrate in a murder case. The cause of his skipping was a hesitation waltz record, being played by City Sales Manager S. E. Lind, who also was impersonating, facially, an owl. Following the music painstakingly, missing not a step, and apparently fearful of being interfered with, the dancer persisted until the record was finished. Then he spoke up briskly: "I'll take that one. And I think that'll make enough, for this time."

After he went out Mr. Lind explained: "He's the head of a dancing academy, William J. Garand, selecting a new orchestra for this month. In the past few months we have sold a good many grafonolas to parties who wanted them for dancing in their homes, but not until a few weeks ago did we sell one to take the place of the orchestra in a dancing academy.

"He wasn't dancing in here just to be gay, but to ascertain if the tempo of the record was right throughout. He tries every record he buys in that way. They must be a pretty good lot of records, for he never has turned one down."

The sale of records is the feature of the talking machine business in Detroit just now. It is so tremendous that it makes the sale of the machines a matter of secondary consideration. The dealers are generally agreed that the wonderful stimulus is the craze for dancing. It was a craze two or three months ago, as mentioned in this correspondence at the time, but it has become more pronounced every week. Perhaps three-fourths of the records sold are dance records, mostly hesitation, one-step and tango. As the business in the other classes of records has not diminished, some idea of the general increase can be had.

The sales of machines have not slumped, however. "As a matter of fact," said Harry Rupp, manager of the talking machine department of Grinnell Bros, "the late highly prized holiday trade turns out to have been but an incident. If it were not for the calendars we might think that January and February were the holiday months. A year ago January and February were almost as good as December, and this year we have double the space and all the rooms are occupied most of the time. For Christmas we sold a lot of machines, which created a tremendous demand for records, and the records, heard by friends of the owners, creates a demand for more machines. The consequence is that we are short of records, and I

guess everybody else is in the same position."

Out in the State conditions are largely similar. Piano houses who took on talking machines a few years ago just as a little side line, are now handling them on equal terms with the pianos, if not actually as the leaders. They are attractive because sales are easier made at the lower prices, and the money is turned over more quickly.

The J. L. Hudson Co. will soon make alterations in its talking machine department, which will almost double the space devoted to it. Another row of demonstrating rooms will be built and the number of record cases will be about tripled. A complete catalogue of Victor and Columbia records will be carried hereafter.

Manager E. K. Andrew, of the talking machine department of the Hudson Co., recently duplicated S. E. Lind's feat of selling a Columbia to a dancing academy owner. Another notable sale by him was a \$200 Victrola to William B. Thompson, twice mayor of the city, and one of the best known among Detroit's business men. A. J. Fedewa, one of the company's talking machine salesmen, who has been ill since last May, returned to his work February 1.

The talking machine salesmen are all participating in the "Efficiency Course" of the Detroit Board of Commerce. This is a series of lectures by prominent business and professional men, on the various features of commercial life, salesmanship being a strong leader. Most of the companies pay the attendance fees for their salesmen, considering it a good investment.

All sections of the city are now well covered with talking machine stores. Detroit's suburban business is spread out over a wide area, and the talking machine jobbers have looked up every cluster of business houses worth while, and have established an agency in the neighborhood. All these stores begin with the talkers as a side line, but most of them, in the course of a year, find that it is more profitable to make the talking machine business the mainstay, and carry the other things as side lines.

"The situation resembles the automobile situation a good deal," said one of the jobbers. "People are just finding out that they are able to have something which they want very much. Perhaps there are a couple of million families in the country that have talking machines. They represent ten million of our hundred million population. Of the other ninety million, count out about twenty million as unable to buy a machine, and that leaves us about seventy million prospects, all getting ripe fast. That is why we do not consider what seems to be a phenomenal trade now, as phenomenal at all, but only what we ought to expect, and which we have every reason to expect will be doubled in a year from now."

The talking machine business is attracting some

of the best piano houses which hitherto have not designed to consider this line of the musical trade. J. Henry Ling, head of the oldest piano house in the city, stated recently that he was seriously considering closing out one of his piano departments and substituting talking machines in its stead.

"I have practically determined on this course," he said. "I want to make one little inquiry to satisfy myself on a certain point, and I am going East soon to do it. Talking machines are becoming one of the biggest forces in the music trades, and affairs have reached a stage that makes it bad policy for a piano dealer to ignore them longer."

EMPLOYEES' ASSOCIATION A SUCCESS.

The Victor Co-operative Beneficial Association Makes Excellent Record During First Few Months—An Example of Victor Co. Generosity—Big Increase in Membership.

The manner in which the Victor Talking Machine Co., of Camden, N. J., has the interests of its thousands of employes at heart is indicated by the first report of the Victor Co-operative Beneficial Association, covering the period from its organization, on April 15 of last year, to December 31, and the best proof of the success of the new venture and its appreciation by the employes of the company is found in the fact that the membership in the association, commencing at 1,647, during the first weeks following the organization, rapidly increased until at the end of December there were 4,210 employes enrolled.

Since the launching of the association, the Victor Co., as per its agreement with its employes, has contributed to the treasury, dollar for dollar in proportion, the amount paid by the employes up to December 31 being \$8,359.50, and by the company an equal amount. With accrued interest the amount raised last year for the association was nearly \$17,000, all of which was devoted exclusively to requirements of the association, the Victor Co. paying all the operating expenses of the association, which amounted to nearly \$2,000.

In less than nine months the association paid to 208 sick members, benefits totaling \$5,861.75, and paid death benefits aggregating \$900 for six members, leaving nearly \$10,000 in available funds in the treasury. All cases of sickness are carefully investigated by the proper officer of the association and when any doubt exists as to the right of the member to receive benefits, the matter is placed before the trustees. Where possible the member is given the benefit of any doubt that may exist.

All concerned acknowledge the Victor Co-operative Beneficial Association as a powerful factor in cementing the cordial relations existing between the Victor Co. and its employes.

The officers of the association appointed for 1914 are: Trustees—A. W. Atkinson, I. F. Burton, C. S. Wickes, E. T. Kieffer, E. K. Smith, W. B. Fulghum; president, R. L. Freeman; vice-president, E. F. Haines; treasurer, G. W. Jagers; secretary, E. K. MacEwan; visiting secretary, M. W. H. Holden.

STOCK SHORTAGE CHIEF TROUBLE IN NEW YORK CITY

Local Dealers and Jobbers, However, Losing Few Actual Sales for Machines and Records—Dance Craze Leaves Mark in Heavy Record Demand—Some Lively Advertising Campaigns Help Business—What Some of the Prominent Local Houses Have to Report.

A shortage of both machines and records of the most popular types has been the most important feature of the local talking machine trade the past month. Shortage of product around the holiday season is expected, but the prosperity of the talking machine industry as a whole is well evidenced by the continued demand that has existed for machines of the more popular prices, and records of practically every type. Although the shortage has not been so marked that the dealers have been forced to lose many sales as a result, at the same time the jobbers and dealers are unanimous in stating that they could easily handle considerably more machines and records than are now being turned out by the factories.

General business conditions the past month have been very satisfactory from every standpoint. Trade has kept up remarkably well and, what is more important, collections have been excellent. There is no doubt in the minds of the members of the local trade but that 1914 will be the banner year in the history of the talking machine industry, and this optimistic prediction is verified by the reports of the factories, which proclaim the month just ended as the best January they ever experienced. The jobbers and dealers throughout the country were responsible, of course, for this record-breaking business, and New York and vicinity have certainly shared in this general prosperity.

Dancing Craze in Full Blast.

The dance craze continuing at full blast, it was to be expected that the demand for dance records would be correspondingly heavy, and in view of this expectation the majority of the dealers naturally ordered what they considered exceptionally large quantities of this class of records. To their great surprise, however, their stocks in most instances fell far below the demand and they are finding themselves in the position of reordering records which they expected would be in stock for at least the next two or three months. The country-wide popularity of the modern dances is beyond adequate explanation, but the talking machine dealers are not trying to solve it, as they are finding it sufficiently difficult to take care of the trade that this dance craze has created.

The Victor and Columbia factories are working to full capacity to turn out enough of the popular priced machines to take care of the needs of the trade, while the Edison disc factory cannot supply its dealers with sufficient stock in the machines retailing at \$150 and over. All three companies are behind in their record shipments, but are doing their utmost to catch up with their trade.

Steady Advertising Campaign.

A steady advertising campaign in the local newspapers has been carried on by the trade during the past month, and the talking machine advertisers, taken collectively, have probably used as much space within the past few weeks as many of the merchandise fields that far outranked them in earlier years. The advertising is well conceived and impressively worded, many of the separate advertisements utilizing educational selling arguments as well as straight-from-the-shoulder "reason-why copy."

A Talking Machine Block.

With the opening of the new store of Landay Bros., at 427 Fifth avenue, there will be presented the spectacle of two Victrola stores and one Edison disc establishment on the same street, and within two doors of each other. This condition is common in several other large cities, but this will be the first instance in New York of three talking machine stores and departments being situated on one of New York's business streets. The new Lord & Taylor store, which will open next week, is located on Fifth avenue, between Thirty-eighth and Thirty-ninth streets, directly opposite the new Landay store, and will have a handsome Victrola department, equipped with about ten sound-proof demonstration rooms. At 433 Fifth avenue, New

York, a few doors north, is the beautiful home of Hardman, Peck & Co., the prominent piano house, which recently opened an Edison disc department on the fifth floor of its building. There is doubtless plenty of business for all three stores on this one street, as with the opening of the Lord & Taylor store this particular location will be traversed by thousands of shoppers who concentrate their purchases on the highest class of goods and pay cash almost invariably.

High-Priced Machines in Demand.

"We are more than satisfied with the success of our Edison disc warerooms," stated Ashley B. Cohn, vice-president of Hardman, Peck & Co., 433 Fifth avenue. "Our clientele has always been an essentially high-class one and in establishing our Edison disc department we placed before them a line of phonographs and records which appealed to their love for the beautiful and the best. Practically all of our sales of Edison phonographs have been confined to the types selling at \$150 and over, and we find that our patrons are sufficiently impressed by the musical and artistic qualities of the Edison disc product to order the more expensive machines in preference to the cheaper ones. We have heard nothing but praise for the Edison disc record, which, many of our visitors have stated, is the acme of musical perfection in a disc record."

Record Demand Is General.

"No, the dance record is not the only class of record that is selling particularly well," answered V. M. Moody, sales manager of the New York Talking Machine Co., 81 Chambers street, Victor distributor, in response to a recent inquiry. "The present record demand is far from being confined to any one type of record, but, on the contrary, embraces practically every class of record in the Victor catalog. Take, for instance, this red seal, light classic record sung by John McCormack. During the past ten days we have sold more of this one number than we did in the entire month of October last year. Bear in mind also that October is the time of the year when dealers are popularly supposed to be stocking up for the holiday trade, while January and February constitute a straight sales business. On another light classic record we sold twice as many in January as we did in November last year at the height of the holiday trade. We are very short of machines of certain types, and with our shortage in records, I need hardly state that we are busy—in fact enjoying the best February in our history."

Columbia Trade Very Active.

"We cannot get enough of many of our new machines," states R. F. Bolton, manager of the Columbia Graphophone Co.'s wholesale and retail store at 89 Chambers street. "Our stock is practically exhausted on the following machines: 'Leader,' at \$75; 'New Mignonette,' at \$100; 'Nonpareil,' at \$150, and 'De Luxe,' at \$200. All our dealers report a demand for these machines that is simply remarkable, and it is certainly a tribute to Columbia quality to note the complete satisfaction that our machines and records are giving. We opened a number of new accounts during the past few weeks that give promise of closing an excellent all-the-year-round business, and everything in general points to 1914 as the banner year for our institution."

January Beyond Expectations.

"January business was beyond all our expectations," states Dana F. Parkhurst, manager of the Edison department of the Tower Manufacturing and Novelty Co., 326 Broadway. "We are adding new names to our list of clients day after day, and with our location in the heart of the business district we are in a position, of course, to make an impressive appeal to the downtown business man. This has helped our business considerably, as, in addition, this class of trade has no use for a low-priced machine and very seldom think of purchasing a machine for less than \$100. The Edison disc

machine retailing at \$150 is our big seller and is gaining in popularity rapidly."

Landay Bros. New Store.

"When our new store is completed we will have one of the finest Victor shops in the country," recently remarked Max Landay, of Landay Bros., the prominent Victor distributors, with four stores in the best shopping districts in the city and a new one at 427 Fifth avenue now in course of construction. "We expect to be open for business about the 1st of next month and are leaving no stone unturned to make this new store distinctive and artistic to a degree. We are using a new process for sound-proofing our eleven demonstration rooms that is guaranteed to shut out the slightest outside noise, and this all-important problem was only solved after lengthy experiment and considerable expense. The front of our new store will be absolutely original, consisting of an illuminated glass front that has never been shown in this city, and, as far as I can learn, will be the first one of its kind constructed in this country. All our decorations and furnishings will be dignified and refined to a degree."

Difficult to Get Enough Records.

"We simply cannot get enough records to handle the demands of our patrons," stated Hayward Cleveland, manager of the Twenty-third street store of the Columbia Graphophone Co. "From our operative selections down to our dance records, we are behind in filling our orders, and the true musical value of Columbia records is becoming more and more appreciated by music lovers in all parts of the city."

Blackman's Satisfactory Business.

The Blackman Talking Machine Co., 97 Chambers street, Victor and Edison cylinder jobber, is closing a steady, satisfactory business in both its lines, as indicated by President Blackman's cheery report: "The month of January showed a substantial increase over the corresponding month of last year and February business to date is equally as good. Victor records and certain types of Victrolas cannot be supplied to our trade in sufficient quantities, which fact certainly seems to indicate a general prosperity in the Victor business that is very gratifying."

What Others Say.

"We are gaining new customers for our piano warerooms every month through the medium of our Columbia department," is the pleasing report of F. G. Smith, the prominent piano house, 142 Fifth avenue. "We are convinced that the Columbia division of our business has not only proven successful on its own account, but has also helped our piano and player business."

"All our twelve booths are filled during the greater part of the day," states Miss Ruby Spaulding, manager of the Victrola department of the Aeolian Co., 29 West Forty-second street. "Last month was the best January in our history and the outlook is very encouraging."

Other optimistic reports were received by The World's representative from the following: Benj. Switky (Victor), Krakauer Piano Co. (Edison disc); Fuller, Bagley & Beers (Columbia), Bremer Co. (Victor), Guy Warner (Edison disc), F. G. Smith, Brooklyn (Columbia).

F. K. DOLBEER IN SEATTLE.

Sales Manager for Thomas A. Edison, Inc., Attends Opening of Pacific Phonograph Co., Northwest, Edison Distributors in That City.

(Special to The Talking Machine World.)

SEATTLE, WASH., February 6.—F. K. Dolbeer, sales manager of Thomas A. Edison, Inc., was recently in the city in connection with the establishment of the Pacific Phonograph Co., Northwest, which will be distributors of the new Edison disc line of the machines and records. A. R. Pommer, of Los Angeles, is interested in the company. C. O. Baker will be the resident manager.

INCREASES CAPITAL STOCK.

The North Chicago Talking Machine Co., Chicago, increased its capital stock recently from \$1,000 to \$6,000.

EDISON'S Supreme Triumph



A Sensational Success

After four years of constant labor, Thomas A. Edison has reached his great goal—**PERFECT REPRODUCTION OF SOUND.**

Everywhere the new instrument is shown public interest is aroused to such a high pitch that the stores of the Edison dealers are **crowded with people** who want to hear this new marvel of Edison's ingenuity and patience.

They Come—They Listen—They Wonder—They Buy

The tremendous sales made in Chicago during the past few months is absolute proof of a genuine interest in the New Edison.

The wonderfully perfect tone of this superb new instrument is just what the public has been waiting for.

No Needles—no scratching—no destruction of sound waves. The smooth, highly polished diamond key is exactly fitted to the groove and slides lightly without the slightest wear on the record.

Record stock does not become second hand by demonstrating.

Send the coupon to-day and get our special dealers' proposition.

The New ^{Diamond} Disc Edison

The new diamond reproducer—the new Edison double disc records—the perfect Edison motor—the automatic stop—the scientifically designed sound conveyer that has no leaks—the automatic oiling system—the new designs of cabinets—and what is more important—the perfect reproduction of sound, are brilliant selling points that make big sales.

AND REMEMBER: the new Edison can be made to play all makes of records (foreign or domestic), and play them as you have never heard them played before on any other instrument.

Service

Service is a much abused word. But our service is real service—prompt, efficient, intelligent. You get what you want when you want it.

Advertising Aids

You get the full benefit of our strong advertising service plan. It will help you to make quick sales and big profits. Learn about it.

Send this Coupon To-day

It brings you full information about the special proposition to new Edison dealers. Edison wants the liveliest man in every locality. He is not going to be satisfied with anyone else. Get the details of the special advertising plan that will assist every Edison Dealer to make money.

Send the coupon to-day—right now.

THE PHONOGRAPH CO.

229 Wabash Avenue

CHICAGO, ILL.

Dealers' Coupon

THE PHONOGRAPH CO.,

229 Wabash Ave., Chicago, Ill.

GENTLEMEN: Please send me full information about the new Edison and the special dealers' proposition. Also about your service and the advertising plan.

Name

Address

.....

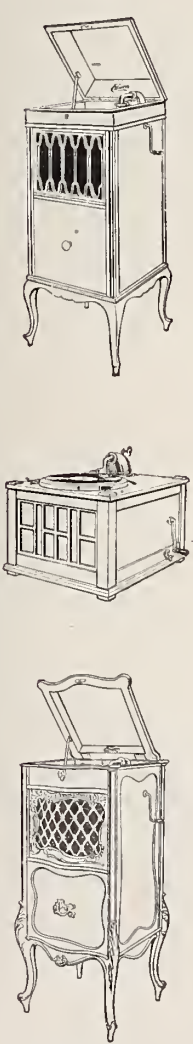

Over 50,000 Satisfied Users

Lyon & Healy

FIBRE NEEDLE CUTTER



EXACT
SIZE

The wonderful success of the Lyon & Healy Fibre Needle Cutter in the last two and a half years is due to the following facts about the cutter:

The Blades of the Lyon & Healy Fibre Needle Cutter are made of the finest grade of properly tempered tool steel. The upper blade is pivoted above and back of the cutting edge of the lower blade. It is held in place by a very high tensioned spring to insure correct leverage and a perfect point at every cutting.

The cutter is fitted with a guide that prevents the cutting away of too much of the needle, and also has a receptacle that receives all the waste. It is very simple and easy to operate, and with ordinary usage should last indefinitely without sharpening.

This cutter is invaluable to all users of the Fibre needle, as a needle may be used twelve to fifteen times where one of the cutters is in use.

Now is the time to get your order in and share in the profits.

Retail Price \$1.50

GET
YOUR
ORDERS
IN NOW

Lyon & Healy

CHICAGO

Largest Victor Distributors

LIBERAL
DISCOUNT
TO THE
TRADE

FROM OUR CHICAGO HEADQUARTERS

CONSUMERS' BUILDING, 220 South State Street, E. P. VAN HARLINGEN, MANAGER.

(Special to The Talking Machine World.)

CHICAGO, ILL., February 9.—The local talking machine trade was a bit startled recently when the Talking Machine Shops came out in liberal space in certain of the dailies and announced with characteristic enterprise that two of the best professional dancers in Chicago had been secured for the benefit of the patrons and friends of the Shops and that a series of afternoon tangos would be given.

The announcement continued as follows: "The dancers are Claude Wickham Kucker, former pupil of Maurice and of Cassell, who is said to be outdancing his teachers, and Miss Buckley, formerly a solo danseuse of the Chicago Grand Opera Ballet.

Between the dances the salespeople would canvass each of the audience, inquiring, "Are you enjoying the dancing? Are you interested in dancing yourself? Have you a Victrola? Have you any of the latest dance records? Would you like to be put upon our mailing list?" and so on, depending upon the answers given by the visitor.

The dancing of Miss Buckley and Mr. Kucker was most excellent and they received hearty applause from the spectators, who were entertained between the dances with some of the Red Seal records and others of the more "popular" class.

The result of the efforts of the salespeople and the favorable impression made by the dancers was made evident when the program had come to an

makes his home in Chicago, has made arrangements with talking machine dealers in other cities

The Chicago Office of The Talking Machine World has removed to new and larger quarters at 1024 Consumers' Building, 220 So. State Street.

whereby he and his partner will be taken away from their home city for some time.

How Mr. Easton Impressed Us.

Edward D. Easton, president of the Columbia Graphophone Co., was a recent visitor to Chicago and inspected the fine new Michigan avenue quarters of the Chicago branch, which he pronounced very good. Mr. Easton directs the destinies of a big corporation, but he is a man whom it is a distinct pleasure to meet. Courteous and kindly he is, and one feels a warmth in the region of his heart long after having come in contact with him. Somehow one loses any daily newspaper inculcated prejudice against big business when its representatives are men like the Columbia's president.

As the above paragraph lay on the desk of The World, a clipping containing a report of an address made by the manager of one of the big State street department stores at a meeting of its buyers, general salesmen and assistants. It seems to work in nicely with a reference to a man of Mr. Easton's ability and personality, vide this:

"Devotion to duty leads inevitably to a mastery of all of the intricate demands of any position. The man who is sufficiently engrossed in his duties, to become master of his position, cannot help but compel his employer's consideration for his success, providing the latter is of the right type. The big, broad-minded virile man of the hour, and only such men can succeed to-day."

Boss the "Talker" Business, Too?

Oh, yes, we escorted our wives and our sweethearts to the registration polls last week, and dreamed dreams of the coming age when the feminine contingent will run politics and Government literature, science and art, boss the trade papers, chase news items and hustle for the festive advertisement. Vive la femme!

(Continued on page 40.)



Tango Dancing at the Talking Machine Shops.

They will dance the tango, the maxixe and the hesitation to Victrola accompaniment. The object of these afternoon dances, of course, is to assist the thousands of people who own a Victrola in making use of it as an orchestra for these new steps. And undoubtedly many delightful home parties will be the result of this innovation."

Did the scheme work? It certainly did. People came by the scores and the average daily attendance for the week was in the neighborhood of 250 persons, with dozens turned away for lack of space to hold them.

Our illustration shows only one corner of the big room. From every side the crowd looked on and also carried chairs into the record rooms, where they could stand on them and look over the heads of those in front.

end, for the crowd lingered for some time and, breaking up into little groups, entered the demonstration booths, there to buy records or perhaps a machine.

"While the direct results and sales of machines are alone sufficient to warrant the expense," said G. W. Davidson, "the most pleasing part is the large number of record customers we are making. In a city of this size the general advertising effect is very beneficial and we are making regular patrons of people who before were hardly aware of our location and our facilities for serving them. I am very much pleased with the way things are going and we are re-engaging the dancers for the coming week."

The success of the novelty has evidently made itself known in other cities, for Mr. Kucker, who

The Practical Fibre Needle Cutter—THE WADE

The WADE embodies the right principle, worked out through long experience. It is simple, durable and accurate. It trims the needle at an angle resulting in the best tone.

The WADE cutters are made of the best steel and are absolutely guaranteed.

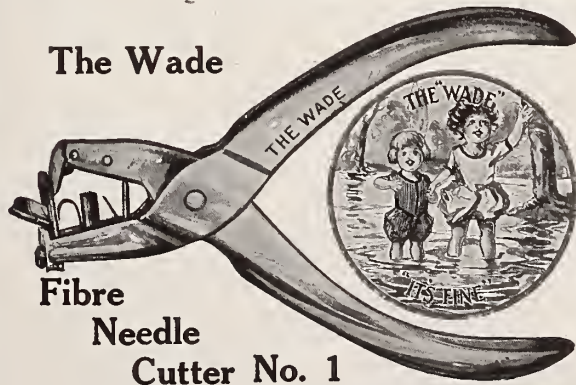

The Wade

Fibre Needle Cutter No. 1

The WADE is the most economical cutter. It has a self-acting stop, which prevents waste and enables one to get from 12 to 15 perfect playing points.

No. 1 is a very popular cutter which has given excellent service. No. 2 has a double action, making it especially easy to operate and affording the most powerful cut of any tool made.

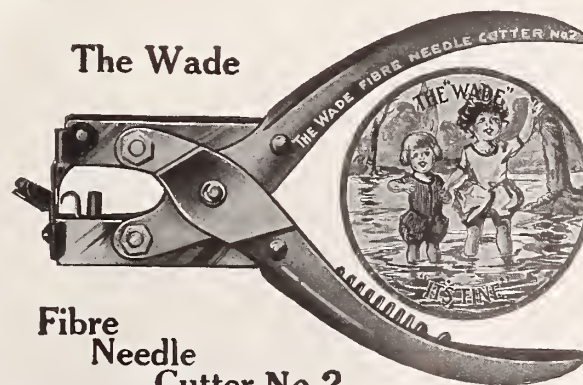

The Wade

Fibre Needle Cutter No. 2

RETAIL PRICES—No. 1, \$1.50; No. 2, \$2.00

Order from your regular Distributor—we sell to Jobbers only

WADE & WADE,

3807 Lake Ave.
PHONE, DOUGLAS 8108
CHICAGO, ILL.

FROM OUR CHICAGO HEADQUARTERS—(Continued from page 39).

Rename Station Healy.

Officials of the Chicago, Milwaukee & St. Paul Railway have decided to rename the station called Pennock, to Healy, in view of the fact that the new factories of Lyon & Healy are within a stone's throw of the station, and the most important feature of the neighborhood. Already there is a vast change in the little suburban neighborhood, and it is quite evident that the big new buildings of the famous music house have started a boom very profitable to real estate owners in the vicinity.

A remarkably good business has favored the Lyon & Healy retail store the past month and all records for January sales have been broken. Steinway pianos and Victrolas have been especially well favored. The Clark Irish harps have also been much favored in the wholesale as well as the retail departments.

Good for Record Shipments.

The Interstate Commerce Commission rates on express shipments within the State became effective February 1 by an order issued by the new Illinois Public Utilities Commission. By this order the old mileage system of computing rates is substituted for the direct distance system. It means a cut in rates, especially on long distance shipments in Illinois.

Uhl Gets Committee Appointment.

E. H. Uhl, manager of the Chicago house of the Rudolph Wurlitzer Co., has been elected to serve on the subdivisional committee representing musical instruments and musical interests of the Association of Commerce. E. C. Barnes, whose place on the committee Mr. Uhl takes, has been transferred to the office appliance committee on his own request. Mr. Barnes, who is the Chicago representative of the Edison dictation machine, thought that he should be classified as a piece of office equipment rather than a musical instrument.

Turns Back to Go Forward.

B. C. Wilt, formerly a Wisconsin traveler for the Talking Machine Co., who a year ago resigned to go into another line of business, has returned to the company's service, and will represent the company in Iowa and Illinois. Mr. Wilt's former work with the Talking Machine Co. was of the most successful nature, and the trade will be glad to know that he is back in his old environment.

Columbia Expansion in Elgin.

The Kimball-Dietrich Hardware Co., Elgin, Ill., which has been handling Columbia goods for some little time, is preparing to enlarge its operations, and this week has placed a \$2,000 order with E. O. Zerkle, the Wisconsin traveler for the Chicago office of the Columbia Graphophone Co., and who ran down to Chicago and then shot out via the Aurora and Elgin Electric to fix up the order.

The Kimball-Dietrich Co. has taken the entire second floor of its building for what will be known as the Columbia Music Store, which will occupy a space of 41 x 50 feet. A large part of the space will be taken up by handsome booths for the graphophone business and the rest of it will be used by Herman Bohnenstengle, well-known musician of Elgin, who has also had a sheet music and small goods department in the store of the Bower Jewelry Co.

Mr. Bohnenstengle will put in a line of the well-known Bush & Lane pianos, handle sheet music and musical merchandise on his own account, and will also manage the graphophone department for the Kimball-Dietrich Co.

Mr. Dietrich, who placed the order, is a progressive young man, who is thoroughly alive to the possibilities in the talking machine business.

T. M. Pointers for Dealers.

One of our largest customers keeps track of just where each sale comes from. When a sale is made, he asks the customer: "Would you mind telling me just why you came to buy your machine here?"—explaining to him that he would like to know how his advertising and circular work are pulling.

"He found 84 per cent. of his sales originated by old customers—satisfied customers—sending in their friends. Every time he found this to be so, he wrote the old customer and thanked him cordially, endeavoring to show his appreciation of

their interest in him. In many incidents you would be able to telephone the old customer and thank him. You know it is a fact the biggest asset in this business is satisfied customers and their good will."

The above is just a sample of the ammunition which the Talking Machine Co., of this city, is continually supplying its customers for their selling campaigns. It is from its circular letter of advice of February 21. Here is another cartridge from its bulletin of January 22:

"Capitalize the Dancing Craze.—An offer to loan a Victrola and a selection of dance records for a tango tea or turkey trot dance, has been productive of many a good sale. We have some excellent sample letters for mailing to just such prospects."

The company recently sent to its dealers a copy of one of the ideas developed by a Chicago advertising concern, and on which the dealers can get estimates through the Talking Machine Co. if he desires to adopt it to his own use. It consists of a cover for the monthly bulletins, to be sent to the retail customer. The cover is full of good Victor advertising matter, exploiting the individual dealer and also contains an approval record order, which can be torn off, stamped and sent to the dealer by the recipient. The write-up will be changed each month, appropriate to the new list and the color scheme will match the Victor supplement.

We Are.

Are we musical out here in the wild and woolly? Are we? The board of directors of the Chicago Grand Opera Co. desires to announce at this time the continuance of the opera for the coming year, and the permanence of the organization in its annual performances in Chicago * * * The board of directors is pleased to state that for the season just closing, the sale of season tickets for seats was considerably higher than during any previous year, indicating that the interest in grand opera in Chicago is not only surely and rapidly increasing, but is permanent. And the Mason & Hamlin was used and probably ever will be.

Moreover we have got one of the largest, if not the largest musical colleges in the world, all sorts of civic music plans are cooking and the new Chicago office of The Talking Machine World has fine mahogany-fixture quarters.

Baer on Biz.

C. F. Baer, manager of the Chicago office of the Columbia Graphophone Co., is very optimistic about business, past, present and prospective. The wholesale business of the Chicago office was way ahead of the corresponding month of last year. The record business, in fact, nearly doubled. The orders for the new 25 cent. demonstrating records are something phenomenal, and as a result the lists of users of Columbia records is being increased by hundreds.

When the Columbia moved over to Michigan avenue, many people predicted that the retail business would fall off. In fact, some of the Columbia contingent themselves had a few doubts on the subject, but Mr. Baer says that the unexpected has happened, and notwithstanding the disorganized condition of things incident to moving, the deterrent advertising of the erection of a new building near-by, the retail business is way ahead. If there has been any loss on the sale of the cheaper class of goods, it has been compensated for by the increase in the high-grade business. In the new location they are selling very few machines under \$75. Probably after the location becomes better known and people get rid of their timidity regarding Michigan Boulevard, more lower price business will come, but as it is, sales in dollars and cents, both in machines and records, is far ahead of the Wabash avenue store.

How Hath the Mighty Fallen.

The store formerly occupied by the Columbia Graphophone Co., corner of Wabash avenue and Washington street, now exhibits a giant fish, 30,000 pounds in weight, forty-five feet long, twenty-three feet in circumference, eight feet in diameter. Its mouth is thirty-eight inches wide and forty-three inches deep, and its tongue forty inches long. The

liver weighed 1,700 pounds. It is not a whale, but a fish, because it has gills. Earnest research has failed to find any relics of Jonah in the giant's inside, but archaeologists and ichthyological experts have their suspicions nevertheless. Some people say that this exhibition is almost a desecration of the quarters so long and honorably occupied by the Columbia Graphophone Co., but it must be remembered that the fish is dead, while the Columbia Co. in its new quarters on the automobile-crowded Michigan avenue is very much in the swim.

National Association Plans.

L. C. Wiswell, manager of the talking machine department of Lyon & Healy, returned a few days ago from the East. He visited the Victor factory at Camden, and reports that the record plant is working night and day with greatly increased capacity.

Mr. Wiswell stopped at Pittsburgh and had a conference with J. C. Roush, of the National Talking Machine Jobbers' Association regarding the arrangements for the coming convention at Atlantic City. It was decided that everything possible shall be done to avoid a bad taste in the members' mouths after the convention. In other words they will not sit around and wonder what it was all about. Plans are working for a program that will be constructive in its character so that the members will feel that they have learned something of benefit to them in their business.

A very strong effort will be made to have not only the department managers, but the owners and chief officers of the various jobbing concerns present at the convention.

This will have the effect, Mr. Wiswell and Mr. Roush believe, of making the heads of houses take the business more seriously and cultivate profound respect for the association and its accomplishment.

Along this line it may be stated that there is a probability of a surprise or two for the members in the way of the presence at the convention of dominant figures in the industry. It is very likely that there will be a meeting of the arrangements committee called for some time this month in Chicago.

Visitors and Personals.

H. C. Baish, recently of the talking machine department of Lyon & Healy, has returned to the Victor Talking Machine Co., from whence he came, and is covering Nebraska for them.

E. F. (Doc) O'Neill, of the wholesale department of the Victor Talking Machine Co., paid one of his angel visits within our pearly gates recently.

Thomas Butler, Wabash, Ind., was in buying machines and records.

Columbia Polyglot Department.

The Chicago office of the Columbia Graphophone Co. has installed a department for the marketing, both in wholesale and retail, of the Rosenthal language system for which the Columbia Co. makes the disc records. The German, French and Spanish courses are offered. The linguistic onslaught from the disc records is large in volume and clear in announcement, and evidently if the prospective tourists cannot parlez-vous, sprechen sie, or usted habla—as a result of his Rosenthal-Columbia disc lessons, he is hopeless.

R. G. Winter, who has for some time successfully conducted the campaign waged from the Chicago offices for the installation of Columbia graphophones in the public schools, is also in charge of the new language course department. He is working the two lines practically in unison and is getting mighty good results.

Absolutely!

A Chicago daily made the remark that the exports of canned goods from the United States reached an enormous figure last year, and that it didn't include canned music either. "We" might add that canned music decidedly *does* "count," nevertheless.

Visits Lakewood.

W. H. Sajewski made a trip to Lakewood, Mich., a short time ago to superintendent the work upon a large dancing pavilion that he is erecting there.

(Continued on page 42.)

The Biggest, Healthiest Growth in the Talking Machine Business

¶ Eight years ago a business small, and weakened by attempting a retail mail order business and half-hearted wholesale business.

¶ Then a re-organization—retail thrown out entirely. ALL EFFORTS CONCENTRATED ON A DISTRIBUTING BUSINESS.

¶ Since then a steady growth made possible by a definite effort to build up our business by building up that of our customers.

¶ Ours is a concern in which exists the strongest loyalty between employer and employee. The concern's employees have never worked FOR the Talking Machine Company—but WITH that concern.

¶ These facts—no doubt—have brought us to that point which makes us to-day the LARGEST EXCLUSIVE VICTOR WHOLE-SALER in the country.

¶ But—MR. DEALER—while these are days of wonderful successes in the Victor line—still through shortages we have had great disappointments.

¶ We are all MAKING MORE MONEY than we ever did before—but we see shortages which make us think how much more money we could have made—forgetting OUR WONDERFUL GAIN in spite of certain shortages.

¶ The Talking Machine Company is probably filling its orders more completely and with greater dispatch than others.

¶ TRY US.

¶ If we can't fill all of that order—the portion we do fill will make you forget your transportation charges wherever you are.

THE TALKING MACHINE COMPANY
12 N. Michigan Avenue Chicago, Ills.

FROM OUR CHICAGO HEADQUARTERS—(Continued from page 40).

Builds Demonstration Booths.

A. H. Dannemark, of Wilmette, has just completed three new demonstration booths, which add greatly to the attractiveness of his store. Mr. Dannemark is an enthusiastic Victor representative, and he also recently installed the new Edison disc.

New Dance Records Expected.

Dealers are anxiously awaiting the extra special dance records that are being issued by the Victor Co. Calls for the Tango, the Maxixe and the Hesitation continue unabated, and buyers of this class of records will find a good deal of pleasure in "Some Smoke" and "Leg o' Mutton" which are played by Europe's society orchestra, composed entirely of colored talent.

Secures Dean Agency.

James Lyons, 25 West Lake street, has secured the Western distributing agency for the John M. Dean "Puritone" needles.

Music for the Children.

Beginning last Saturday morning Lyon & Healy instituted a series of recitals for children in their recital hall, using the "Educational Series" of the Victor Co. Miss Elsa Stein was in charge of the selection of the records and talked to the children and visitors to the series were very much pleased with her efforts to instruct as well as to entertain the children, who ranged from six to fourteen years of age. Many beautiful standard works of musical art are thus presented to the children in such a way as will aid greatly the development of their young minds.

Orders Stock.

George Eichholz, one of the big dealers of Milwaukee, Wis., visited Lyon & Healy's recently to see about the replenishment of his stock.

New Lyon & Healy Traveler.

L. A. Cummings, formerly one of the star travelers of the Victor Co., is now traveling for Lyon & Healy, succeeding J. B. Ryde, who will come into the house to take charge of detail work in the wholesale sales department. Mr. Cummings will have Illinois for his territory as well as river towns in Iowa. He is well known to the trade generally, and will be welcomed by a number of friends.

Personals and Visitors.

Arnold Lockerby, who was formerly connected with a prominent talking machine company in Grand Rapids, Mich., and later in charge of the talking machine department at Hillman's, has returned to his home in Grand Rapids and has entered the furniture business.

Expert Decorator at Wurlitzers.

Ellis P. Hansen, formerly window dresser expert of the Victor Talking Machine Co., is now associated with the Rudolph Wurlitzer Co., and has in preparation many novel window displays, which attract the passer-by to the already busy talking machine department of that company.

Assistant Manager Fred Siemon reports that this January is far ahead of previous Januarys and that the record business is "really great." "The higher priced machines are certainly selling far more rapidly," said Mr. Siemon, and the \$100 and \$150 machines seem to be holding the center of the stage at the present time. This is as we would like to have it, and the buyers of the bigger machines are, of course, more liberal in their record purchases."

The New Manager.

Ella Lentz is the new manager of the talking machine department at Hillman's. Miss Lentz is an old employe at Hillman's and received her knowledge of the business while in the employ of that company.

Selling Large Edison Machines.

C. E. Goodwin, manager of The Phonograph Co., is wearing a broad grin these days, which is due to a great extent to the large volume of business which has followed the liberal advertising campaign which this company has recently launched. "The Edison has proved that high-priced machines are the ones that carry the profits with them. We are selling more of the \$250 machines than all of the other instruments put together.

This is profitable in more than one way and the customer who is in a position to buy such a machine is naturally better able to own a comprehensive library, and then again, there is no more effort nor no more time and fuss required to sell a \$250 instrument than a \$50 machine.

"There is still a shortage in the supply of records, although the completion of the new record factory at Orange has alleviated the unfavorable conditions. Although the supply is still inadequate, we have fared very well, and hope to be filling all orders before very long."

Installs Foreign Record Stock.

F. J. Bukowitz, manager of the talking machine department of the F. G. Smith Piano Co., has installed a comprehensive stock of foreign records. He has also arranged for the services of a linguist who can speak five of the foreign languages, including Polish and Croatian. Mr. Bukowitz has also arranged for agents in certain of the thickly populated foreign districts, and is already reaping a rich harvest of orders from these sources. January was exceptionally good at the F. G. Smith store, the total of Columbia records and machines reaching seven-eighths of the December business.

Double January Business.

Wade & Wade, manufacturers of the Wade fibre needle cutter, nearly doubled their business last month, as compared with the corresponding month

of 1913. The Wade cutter was handled by the majority of the jobbers of the country, and in the last few weeks quite a few of the remaining ones came into line. The further additions to the equipment of the firm's up-to-date factory are being made.

Talking Machine Co. Sales.

January was one of the best first months in the history of the Talking Machine Co., both in the sale of machines and records. The business on the latter was something enormous. Sales Manager R. J. Keith called attention to the very large number of responsible merchants who had recently made application for the Victor line, but who had not been signed up on account of the shortage in Victor goods, or because the line was already well represented in their locality. A large stack of letters of inquiry that were temporarily held up for the reasons above stated was shown the caller.

Mercer With Columbia Co.

J. P. Mercer has joined the Chicago branch of the Columbia Graphophone Co. as assistant to Manager Ryers of the retail department. Mr. Mercer is an old piano man, and many years ago was the Steinway agent at Dayton, O. He also handled talking machines in those days, and tells interesting stories of his experiences with the first Edison phonograph of the old barrel tin foil type.

A BEAUTIFUL PRESENT.

Something About That Leather-Bound Order Book Given by the Talking Machine Co. to Its Dealers and What the Latter Think About It—Should Act as Spur to Recipients.

(Special to The Talking Machine World.)

CHICAGO, ILL., February 9.—Brief reference was made in the January World to the handsome order books which were sent by the Talking Machine Co., Victor jobbers of this city, to their dealers. A photographic reproduction of the cover of the book is presented in this connection.

It is extremely artistic, bound in gray flexible

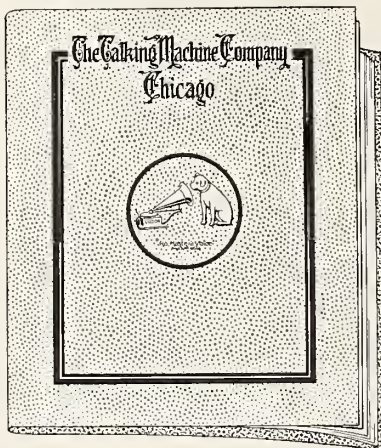

Cover of Talking Machine Co. Order Book.

leather cover and lined on the inside with moire silk. The order pad, which is removable, contains twenty-five order blanks in triplicate, with a place for the carbon in the back of the book. The additional order pads can be obtained from the company upon application as required. As will be seen, the Victor trade-mark and the name of the Talking Machine Co. form integral parts of the embossed design. The World was given the privilege of running over some of the acknowledgements written to the Talking Machine Co. by pleased recipients. They are of interest not simply because of the kind words said about the order book, but owing to the evidence of its hearty spirit of co-operation between enterprising dealers and vigorous, up-to-date wholesale houses with a particularly high reputation for the excellence of its service. Here are extracts from some of the letters:

"We want to thank you for the beautiful leather-bound order book which you sent us for Christmas. It will be an inspiration to keep our orders in better shape than ever before, and we must say

that you remembered your customers in fine shape."

"Your 'order blank cover' and greetings received, for which please accept our thanks and good wishes for your success in the future, especially during the new year, that of 1914."

"Please accept my cordial thanks for the very beautiful order book cover. Hope to be able to send you many orders from it during the coming year."

"Please accept my thanks for the lovely leather cover sent with the season's greetings."

"Enclosed please find acknowledgement of receipt of your Christmas gift. It you will give the acknowledgement as quick attention as I have the gift, the service will be O. K."

"We wish to thank you for the fine leather-covered order book, which we expect to use quite extensively."

"The cover is artistic and 'classy,' to say the least."

"It is a beautiful piece of work, and we shall make it useful as well as ornamental."

"Very 'swell' book, thank you."

"We are in receipt of your order book of recent date, for which accept our thanks. We trust our business for the coming year will be of such volume that we will have use for it many times."

"It is very neat and artistic in design. Wishing you a happy and prosperous new year—"

"Accept our sincere thanks for the fine order book you sent us. Hope we can fill out all the order sheets for records and machines."

"We beg to acknowledge receipt of your exceptionally attractive and practical order sheet booklet, and with reciprocation of your good wishes, we remain—"

"Thanks very much for the leather cover—its a fancy."

"We are having a great Christmas business and wish to thank you for your promptness in filling our orders. Your Christmas present of an order book cover was received yesterday. Thank you for remembering us."

"We desire to thank you for the order book sent us. Wishing you a prosperous new year, we remain—"

"Both the Victor and Edison Companies are giving recognition at last to Boston song composers," declared a member of one of the Boston companies. "Compositions of several of these are now to be had on cylinder and disc, among them the pieces of Leo Feist, Tommy Allen, through their manager, Billy Lang, and these are now on the market. 'Chick' Story is another who will get good representation next month."



Have you investigated the margin of your profit on Columbia 65c. double disc records? You should.



(Write for "Music Money," a book "full of meat" for those dealers interested in quick and frequent turnover of capital.)

**Columbia Graphophone Company
Woolworth Building, New York**

REPORT SHORTAGE OF STOCK IN MILWAUKEE TRADE.

Jobbers for Leading Lines Say They Are Meeting with Brisk Demand for Machines and Records, but Find It Difficult to Fill Orders Owing to Shortage—Many Changes and Enlargements in the Leading Stores to Meet Expanding Business—The News in Brief.

(Special to The Talking Machine World.)

MILWAUKEE, WIS., February 10.—The only question that is troubling talking machine jobbers and dealers all over Wisconsin is the shortage of machines at the present time. Jobbers for all the leading lines say that they are meeting with a brisk demand from retailers for machines and records, but that they are finding it difficult to fill orders because of the inability of the factories to turn out the goods fast enough. Dealers in Milwaukee and about the State met with a big holiday business and stocks were reduced to a low stage in most lines. Jobbers are looking for a good business for the next few months, as they realize that it is going to take some time for dealers to get their stocks back in normal condition.

Business Shows Improvement.

Prospects for the coming year are much brighter at this time than they were a month ago. General business in Milwaukee and about the State has shown decided improvement, and this has reacted favorably upon the talking machine trade. Most of the large, heavy machinery manufacturing concerns in Milwaukee are increasing their working forces and are again operating on almost full time. Money is somewhat easier and confidence is more widespread. Collections have been improving since the first of the year.

The demand for the higher priced machines is still strong, but the sale of cheaper machines is increasing, now that industrial conditions are resuming a normal stage and people have work once more.

Finds It Hard to Get Stock.

"Dealers all over the State have been ordering freely since the middle of January," said Harry T. Fitzpatrick, general manager of the Wisconsin Talking Machine Co., jobbers for the Victor line. "The only trouble is that we are finding it hard to get enough stock from the factory to meet the demands of the trade. The Victor Co. seems to be rushed and is finding it impossible to turn out the goods fast enough. We have secured a large number of new Victor dealers about the State since the opening of the new year. The prospects for 1914 are unusually bright and we are con-

fidant that business will attain a new high mark." **McGreal for Congress.**

Lawrence McGreal, sheriff of Milwaukee County, for many years a prominent talking machine jobber of Milwaukee and a former president of the National Association of Talking Machine Jobbers, will be a candidate for Congress from the fifth Congressional district on the Democratic ticket. Mr. McGreal will make the formal announcement of his candidacy within the near future.

Gain of More Than 23 Per Cent.

L. C. Parker, enterprising manager of the Victor department at Gimbel Bros.'s Milwaukee store, experienced a gain of more than 23 per cent. in the business received during 1913. Business during January made a new high gain of 47 per cent. Victor machines have been sold to several more of the public schools by Mr. Parker and his sales force.

To Double "Talker" Department.

Before the coming fall season there will be a big change made in the Victor talking machine department at the Boston store, steps having already been taken for doubling the size of the department. Manager C. W. Abbott has felt for some time that even greater possibilities in the way of increased trade might be attained if larger space and better facilities were to be provided. Manager Abbott has added a new outside salesman, F. W. Holtz, who is spending most of his time in calling upon the city trade in Milwaukee. The Victor business at the Boston store during January showed a gain of 50 per cent. over the corresponding month a year ago.

May Sue the Creditors.

The First Savings & Trust Co., of Milwaukee, trustee in the case of the bankrupt Heller Piano Co., is considering the advisability of bringing a preference suit against certain creditors of the concern, on the grounds that unfair tactics were followed in securing an early settlement on certain claims. The Heller concern carried the Victor line of machines.

High-Priced Goods in Demand.

Paul A. Seeger, manager of the Victor depart-

ment at the Edmund Gram Music House, has been meeting with an unusually fine demand for high priced Victrolas of late. The Victor business with the Gram house is more than double what it was a year ago.

Making Attractive Window Display.

The J. B. Bradford Piano Co., Milwaukee's oldest piano house, which now maintains a highly successful Victor department, has been featuring the Victor goods in window displays and in its daily newspaper advertising with exceptionally good results. The salesmen in the piano department all lend their aid to the Victor end of the business, and these men bring in many good sales in connection with their visits to piano prospects.

Big January Gain.

The Columbia business at the downtown store of A. K. Kunde, 516 Grand avenue, Columbia jobber and retailer, is said to be the best in the history of the establishment. Business during January showed a gain of 60 to 70 per cent. over the same month in 1913. J. H. Ellis, the inventor of the "Real Tone" diaphragm, who is now the manager of Mr. Kunde's new branch store at 3410 North avenue, is confined in the hospital at this writing suffering from a severe attack of pneumonia.

Business Is Steadily Expanding.

The Gensch-Smith Co., operating an exclusive Victor retail store at 730 Grand avenue, met with a business during January which was more than double that received during the same period a year ago. Two new outside salesmen to cover Milwaukee and Milwaukee County were secured last month, but Mr. Gensch says that he is seriously considering the advisability of making other additions to his sales force.

How the Automobile Helps.

Henry Saak, proprietor of an exclusive Columbia store at 1602 Vliet street, has been meeting with an exceptionally fine business in Columbia machines and records. Mr. Saak uses an automobile to a good advantage in "rounding up" his sales.

EDISON PREPARES TO GO SOUTH.

Thomas A. Edison shipped on Monday chemicals and other paraphernalia to his winter home at Fort Meyer, Fla., where he is having his laboratory renovated and made larger. He celebrated his sixty-seventh birthday on February 11, and on February 21 will leave with his family for his Southern home.



The Columbia automatic stop. The most accurate automatic stop made and the easiest to operate.

Gun Metal, \$2.00 list. Nickel Plated, \$2.50 list. Gold Plated, \$3.00 list.

May be adjusted to both Columbia and Victor disc machines.

Order from any Columbia Distributor.

THE CREDIT PROBLEM

Between Talking Machine Jobber and Dealer
Discussed by Louis Buehn, of Philadelphia,
in the Edison Phonograph Monthly.

The credit feature of every business is one that is most important, as many careers have been wrecked by the granting of credits too liberally, particularly to small merchants who did not have the right conception of business, and who brought about losses to the grantor of credit.

It has always been my aim to safeguard the credit situation, in so far as I was personally concerned, by never failing to ask for remittances when an account became due, and to politely but firmly insist upon settlement when the account was past due.

This condition, of course, was largely brought about in the beginning by necessity, but the rule has been so satisfactory that I have continued the practise up to the present day, although liberality also is part of my creed when the condition or situation warrants it.

Many dealers are prone to think that the principal item of consideration in the granting of credit is the amount involved, but in this they are mistaken, for the reason that any jobber will grant any amount of credit to any dealer provided he discounts his bills or pays them promptly on the terms agreed, but should a man owe an amount of money, even though very small, and exceeds the terms agreed upon, the jobber will rightfully refuse to extend an additional amount of credit.

It should be the aim of every dealer to discount his bills, for until he is in position to do this, he is not taking full advantage of the possibilities of the business, and not getting everything out of it to which he is entitled. It should be the jobber's aim to help the dealer realize this condition and the writer has always tried to lend the necessary assistance through advice and the proper extension of credit accommodations to bring this condition about.

It has been my good fortune to see a number of dealers brought from a slow paying basis to dis-

counters and there has always been a feeling of satisfaction on my part of having been partially instrumental in bringing this condition about.

The dealer should not abuse his credit by asking unreasonable things, for by so doing he not only brings down upon himself the condemnation of the jobber, but will usually bring upon himself in time a condition which will mean the giving up his right of dealership. In like manner the jobber should be careful in the extension of credit not to make the terms burdensome or irksome. He should grant credit intelligently and give every dealer all the help possible and should act generally as a constructive force for the good of the entire business.

BUSINESS OUTLOOK PLEASES.

H. L. Willson, assistant general manager of the Columbia Graphophone Co., returned recently from a short trip to the most important trade centers of the Middle West, and is pleased with the general business outlook. Mr. Willson discussed business conditions with a number of prominent financial and industrial men, and the consensus of opinion was decidedly encouraging. While in the West Mr. Willson closed arrangements for the leasing of a larger store at Toledo, to be located a few doors above the present one, and also renewed the other leases.

HOW CO-OPERATION HELPS.

A recent example of the co-operation offered by the educational department of the Columbia Co. was evidenced in an advertisement that was staged last week in Public School 23, Jersey City, N. J., under the auspices of the Columbia educational division. This school had for some time been desirous of purchasing a Columbia outfit, but no funds being available, the purchase was necessarily deferred. The Columbia Co., however, lent assistance by preparing an excellent record concert which, by the charging of a small admission price, produced sufficient funds to buy a Columbia machine and a goodly supply of records.



NYOIL

For polishing
varnished woodwork it is
extremely satisfactory. No oil is so clean.

*Ask your watch repairer whose
oil he uses on your watch.*

NEW COLUMBIA DEALERS.

A. Lasus, of New Rochelle, N. Y., is a recent addition to the lists of Columbia representatives in near-by territory. He has placed a substantial initial order and has perfected plans for the development of an extensive clientele.

Other recent additions to the lists of Columbia dealers in near-by territory, include: William Damrau, Jr., 96 Flatbush avenue, Brooklyn, N. Y., and A. Hammel & Son, Suffern, N. Y.

A special letter sent out to Columbia dealers this week called particular attention to a recent popular Columbia record featuring the latest song hit "I'm on My Way to Mandalay." The surprising demand for this record warranted the sending out of this special letter to dealers.

Another Example of \$witky \$ervice

Victrolas XI Growing Scarce

But Our Dealers Need Not Worry

☐ Last summer we foresaw the condition that is coming. We took in all the Elevenths that the Victor factory could ship us, besides buying up a lot from other sources during the dull season.

☐ Although warehouse charges, interest and insurance have cut into the margin of profit, it was **your benefit only** that we thought of.

Order Now—Order Liberally.

Telephone! Telegraph! Write! Get Busy!

**BENJ. SWITKY, VICTOR DISTRIBUTOR
NEW YORK CITY**

EDISON SIXTY-SEVEN YEARS OLD.

Time Has Dealt Gently with the Great Inventor After Forty-Five Years Spent in Laboratory Work—His Latest Portrait—Planning to Spend Vacation in His Home in Florida.

Sixty-seven years old and working steadily for 120 to 140 hours a week on occasions, an exhibition of energy that would break the health and spirit of a far younger man, is the record that still maintains Thomas A. Edison on a pedestal as one of the foremost figures, if not the foremost figure, in the field of electrical and mechanical invention and development to-day. Mr. Edison's work is indicated by his time card, which he punches just the same as would the ordinary employe, and the results are shown in numerous

his work in the past has entitled him to an occasional vacation without necessitating apologies, and consequently late this month he will leave home for a seven weeks' vacation in Florida in company with Henry Ford, the well-known automobile manufacturer, and John Burroughs, two close friends.

The anniversary of Mr. Edison's sixty-seventh birthday fell on February 11, and the accompanying portrait, his latest, shows that the years have dealt lightly with "The Wizard" and that he still appears to be fit to develop fresh surprises for the scientific and mechanical world.

SUCCESSFUL IN CONCERT WORK.

(Special to The Talking Machine World.)
KEOKUK, IA., February 6.—C. H. Wolfe, an enterprising Viotor dealer in this city, is closing an excellent business through the medium of original ideas in both his publicity and his sales methods.

Mr. Wolfe is a great believer in offering the public something different from the average advertising and he also presents the Viotor products by means of concerts held in various parts of the city.

On a recent occasion Mr. Wolfe prepared an elaborate program for a Viotor record concert at St. Paul's German Evangelical Church, at which sacred music was featured exclusively. The extent of the Viotor record library was well evidenced by the splendid list of sacred records which was offered by Mr. Wolfe. This concert is but one of a series that Mr. Wolfe is planning to offer during the next few months, for the experiment has proven a decided success in increasing sales.

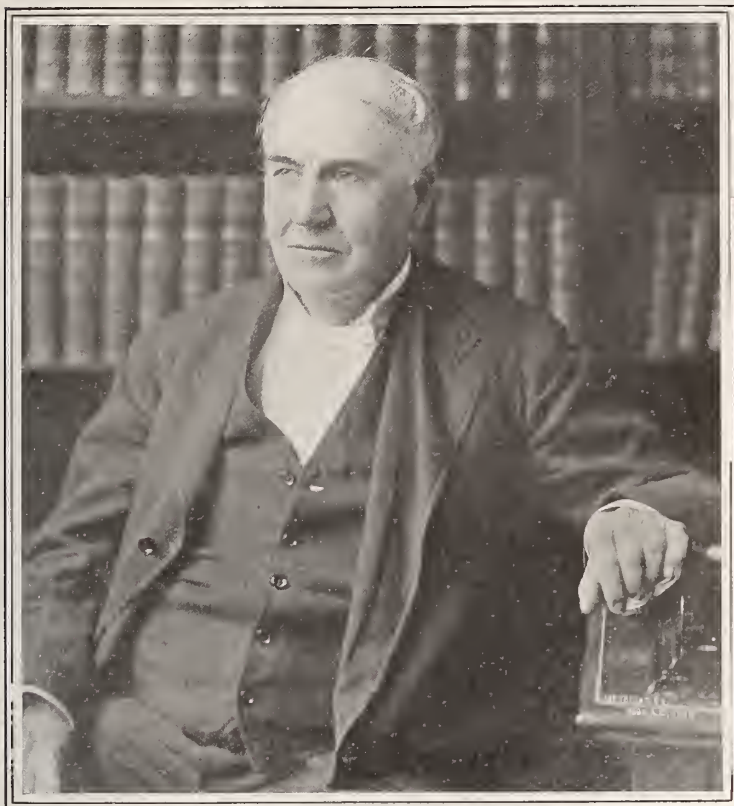

Latest Photograph of Thomas A. Edison.

ways, most recently by the perfection of the disc phonograph. No better proof of the energy of the man is to be desired than his remark upon his return from a recent vacation, enforced by a slight illness, to the effect that forty-five years in the laboratory had so tuned him to hard work that he was sick if away from it.

Mr. Edison is beginning to feel, however, that

PHONOGRAPHISCHE ZEITSCHRIFT

BERLIN W. 30, GERMANY

The oldest and most up-to-date trade paper covering the talking machine line published in the German Language.

PUBLISHED WEEKLY. FOUNDED 1900

Circulates all over the world.

SPECIAL EXPORT NUMBERS appear in four different languages at regular intervals.

Subscriptions for this talking machine publication 10 Marks yearly. Sample copies sent free.

LATEST RECORD BY MAGGIE TEYTE

Announced by Columbia Co. in Special Letter Sent to Dealers—Sings Her Big Hit.

The Columbia Graphophone Co. sent out to its dealers this week a special letter announcing another record sung by Maggie Teyte, the famous English soprano, in addition to those featured in the regular March list of records. The company had originally planned to issue this third record in April, but as Maggie Teyte is scoring a most impressive success in her present tour of the country it was deemed to be the best interests of Columbia dealers to release the third record by Miss Teyte at the earliest possible date.

This record contains Miss Teyte's famous hit, "Mifanwy," which is considered the most popular song in her repertoire. The issuance of this song in record form should prove very popular with Columbia dealers.

"TALKING MACHINE SPECIALISTS."

Burley & Biesinger, "the talking machine specialists," who opened a new store last October, at 278 West Ferry street, Buffalo, N. Y., are handling a full line of Viotoras and Edison Amberolas, records and supplies, and report a very excellent business. Both of these gentlemen were connected with the Neal, Clark & Neal Co.

George W. Lyle, general manager of the Columbia Graphophone Co., left Monday for a ten days' trip through the West. H. A. Yerkes, manager of the company's wholesale department, left Tuesday for a short trip through New England territory.

Make Every Business Day Count

That is the only way to succeed, and if you realized how you could improve your business with the right player-pianos you would lose no time in communicating with us.

We can offer you a player proposition which is brimful of business-building possibilities for you. That means money-making possibilities.

If there is a sub-cellar under the basement we can put you right there, so the foundation is firm; not merely on the ground floor of the player business, but better than that. We can aid you in your business enterprise so that it will show a substantial increase in profits before the year is very old.

We have a player-piano proposition that you should not overlook.

One of the largest piano enterprises in the world could not have been built up within a few years unless the profits had been there—unless we had meant exactly what we said when it came to the question of values.

The question is, are you interested in values?

Are you interested in something unusual in the player line?

Then take it up with us!

H. P. NELSON COMPANY

Makers of Grands, Uprights and
Player-Pianos

North Kedzie, North Sawyer, West Chicago Aves.
and C., M. and St. Paul R. R., CHICAGO.

STABILITY OF THE TALKING MACHINE INDUSTRY.

History of Trade Shows That the Industry Has Grown in a Broader Way Than Anticipated by Those Associated with Its Early Development—Industry Will Live as Long as Music Is Loved, Which Is Forever, Says Benj. Switky, in an Interesting Article.

"How long will the talking machine business last?" This question was frequently asked by dealers and jobbers themselves, as well as by laymen, only a few years ago. Why? Because the phonograph and primitive talking machine were hailed by the entire world as almost supernatural wonders—and wonders, you know, are supposed to last only nine days. As novelties, their only purpose was amusement. Hence it seemed but natural that they should eventually decline in popularity, the amusement lessening with the wearing off of the novelty.

Even those who succeeded in making modest fortunes seven or eight years ago believed that their prosperity would be short lived. They looked upon it as a sort of orange from which they were to squeeze out the juice, then throw the pulp away. The Victor distributor to whose jobbership I succeeded about eight years ago, accepted \$250 bonus as a consideration for the transfer—a mere mess of pottage for a birthright.

Few of the phonograph pioneers would have dared to assert, while looking at the Berliner Gramophone or the little cylinder machines, that these had within them the possibilities of a great industry. How many could have believed that these toys were but the foreword, their sale but the foundation upon which was to be reared a mighty, magnificent structure that within a decade would tower like a serene Alpine peak, loftily above industries whose lineage dated back centuries!

Although our greatest interest lies in the present, and our fondest hopes are concentrated upon the future, it will do us all a great deal of good to contemplate the past, and, while indulging in reminiscence, draw from past performance our inspiration for future accomplishment.

The ancient minstrels sang of the valorous deeds

of still more ancient knights and warriors; and their songs enkindled the fires of courage and loyalty in the breasts of the new generations.

The old men of the talking machine business are still very young; yet the autobiographies of these men would make very interesting reading.

They would be an inspiration and encouragement to the newer members of the fraternity.

Only ten years ago one of our foremost New York distributors, whose present Fifth avenue shops are the acme of elegance and prosperity, began his talking machine career by doing house-to-house selling.

On every hand we see prosperous manufacturers, dealers, jobbers—men recruited from many different walks of life, who within a very few years have built up establishments that are remarkable for their progressiveness and self-evident appearance of success.

Our manufacturers, the captains of the industry, have on every occasion proven their personal courage, their prophetic foresight, and their ability to perpetuate the business. They have lifted their machines out of the toy and novelty class and planted them in the front rank of musical instruments. They have taken their machines, which formerly were stowed away in closets when not in use, and demanded that they be given a place of honor in the parlor, where they eloquently plead our cause. This was done by clothing the instrument in beautiful red and gold, with artistic figure. They are even now spending vast sums of money and immeasurable energy to impress upon the school principal and teacher, and the board of education, that the talking machine belongs in every classroom; that a graded course in music through the medium of the records, should logically be made part of the school curriculum. After that

we will have no difficulty in making the talking machine as necessary in the household as is the sewing machine.

The manufacturers are maintaining expensive laboratories and experimentors so as to improve their product. Following each improvement they point out to us new uses to us for which the machines are adaptable; opening up for us new fertile fields, and spending millions to create the demand.

While there are certain flaws in our business methods that are sadly in need of correction, policies that pinch and hurt, these are but "growing pains." The manufacturers' ideas for the preservation of the dealer and his profits are still a little crude and incomplete, but even these will be righted in time.

The talking machine business will outlive its creators. It will last just as long as music claims its corner in the human breast—which means forever. The present types and styles and mechanical construction may undergo radical changes, but the industry will continue. It can truthfully be compared to the little brook of which the poet Tennyson wrote:

"Men may come and men may go, but I go on forever."

PREPARING NEW WINDOW POSTER.

The Victor Talking Machine Co. is now preparing a window poster and four-page folder to advertise a special list of Victor records for Easter which are detailed on an order blank sent to Victor dealers under date of February 2. This list, which was chosen with particular reference to the adaptability of the records listed to the musical requirements of the Easter season and contains a number of excellent selections that should prove very popular during that season.

Accompanying this list the Victor company sent out a short letter calling the attention of its dealers to the advantage of properly featuring special season records, as this publicity never fails to result in increased sales for the dealer's record department.

The Masterphone

GIVES

Perfect Detail

Rich Tone

Full Volume

Records remain perfect forever, as Victor Fibre Needles are used.

Your customers will like the Masterphone, for it adds immeasurably to the value of their instruments.

YOU EARN ADDITIONAL PROFITS.

Write for Sample and Discounts.

Steel
Needles
Masterphone
\$1.00

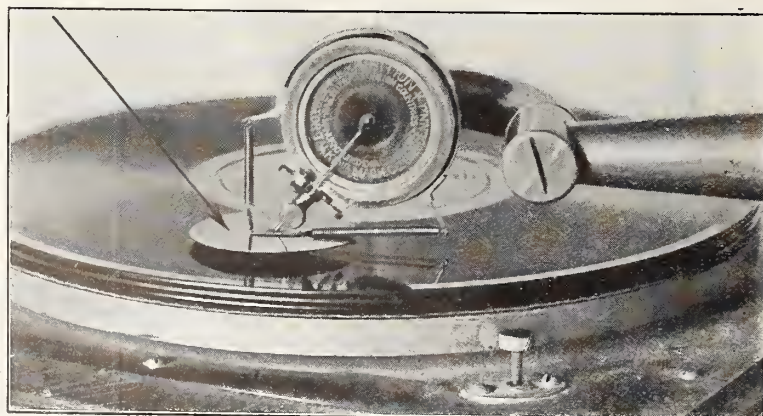

Fibre
Needles
Masterphone
\$1.50

THE MASTERPHONE CORPORATION, 187 Broadway, New York City
Telephone: Cortlandt 1872

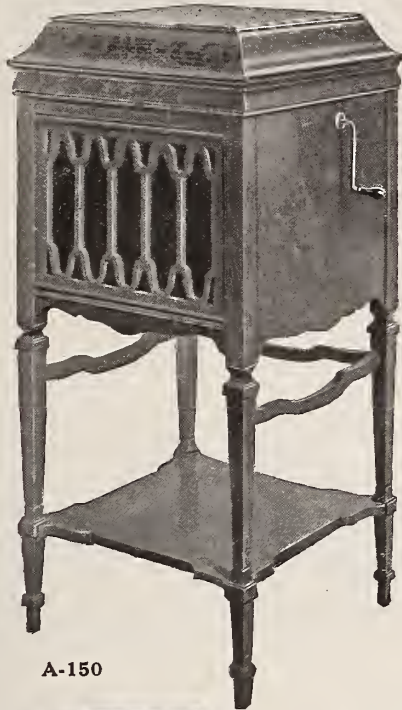

A-150



A-80

Eclipse Phonograph Company

A. W. TOENNIES & SON

203 WASHINGTON STREET HOBOKEN, N. J.

JOBBERS OF

Edison Disc and Cylinder Phonographs Exclusively

Dealers of New York
and New Jersey

Write for terms and discounts.



A-200



A-250

VALUE OF WINDOW DISPLAYS

Emphasized by the Success of M. Sonnenberg Piano Co., Yonkers, N. Y., in Featuring the Columbia Line So Artistically.

The enterprising methods of the M. Sonnenberg Piano Co., Yonkers, N. Y., are well illustrated by the accompanying picture of a recent window display presented by the company on behalf of its



Attractive Sonnenberg Window.

Columbia graphophone department. This photograph, which was taken at night, hardly does justice to the beauty of the display, which was used as a follow-up of the Columbia Co.'s advertising

in the Saturday Evening Post. The Favorite is the machine featured in this display, and the dolls attached to the machine by ribbons made a most attractive setting for the machine.

J. Bareuther, who is manager of the Yonkers store of the M. Sonnenberg Piano Co., is a firm believer in the value of artistic window displays, and the fact that the Columbia business in this store is steadily increasing can be attributed in a considerable measure to Mr. Bareuther's energetic and live-wire publicity and sales policies. The Columbia line is handled exclusively in this store.

CHARGE INTEREST ON VICTROLAS.

Minneapolis Dealers in Victor Talking Machines Sign Agreement to Charge Six Per Cent. Interest on All Instalment Sales.

(Special to The Talking Machine World.)

MINNEAPOLIS, MINN., February 7.—All Victor dealers in Minneapolis, some fourteen in number, have signed a pact to charge interest on deferred payments as is done with pianos sold on the instalment plan. The pact includes two department stores, who were expected to balk on the proposition, but apparently there was little difficulty in signing them. The matter of obtaining the signatures to the agreement was turned over some weeks ago by several dealers at an informal gathering to Robert O. Foster, of Foster & Waldo, former president of the National Association of Piano Merchants.

It is agreed that the interest rate will be 6 per cent., that being the current rate on loans of various kinds in Minneapolis.

MOVE TO NEW FACTORY.

The Schafford Album Co. Has a Modern Equipment in New Plant at 27-29 Walker Street, New York—Manager Skinner's Report.

The Schafford Album Co., formerly on Lispenard street, New York, is moving to a larger factory at 27-29 Walker street, where, with new machinery

and modern equipment, it is planning to increase its output to a considerable extent.

This concern makes a specialty of talking machine record albums and carrying cases, and its business now reaches all over the country, due to the high quality of its goods, consistent with reasonable prices.

General Manager Skinner, in speaking to The World representative, said: "Of course it took a week to move, and during that time we were a little delayed in shipping orders, but we are now settled and, with the additional output, we are in an excellent position to care for the orders of the trade. It is these orders that are making our rapid growth, and we aim to give the best satisfaction both as regards quality, price and deliveries, so that the business may continue to grow."

COLUMBIA CO. TRADE IN BUFFALO.

Business in Both Wholesale and Retail Departments Practically Doubled—Better Grade Machines in Demand at All Stores.

(Special to The Talking Machine World.)

BUFFALO, N. Y., February 7.—According to W. L. Sprague, manager of the Columbia Graphophone Co., in this city, the business of the local store has increased considerably during the past month.

The retail business of the store in this city has increased about 55 per cent. and the wholesale business has been doubled.

One of the unusual features of the marked increase is the fact that Buffalo people are purchasing more \$75 and \$100 graphophones than \$50 machines.

A window, artistically trimmed, adorns the front of the store which is located in Upper Main street in the heart of the music trade center of the city.

Sometimes when duty calls we can't hear it because pleasure keeps up such a racket just around the corner.



**New records—three times a month.
This is the latest Columbia innovation
meeting the demands of record buyers.**



(Write for "Music Money," a book "full of meat" for those dealers interested in quick and frequent turnover of capital.)

**Columbia Graphophone Company
Woolworth Building, New York**

A REAL LIVE WIRE IN COLORADO.

E. Frank Winfield, Proprietor of the Outing Shop, Grand Junction, Col., a Firm Believer in Persistent Advertising and Aggressive Salesmanship—A Window Display of Particular Interest That Tells Its Own Story.

(Special to The Talking Machine World.)

GRAND JUNCTION, COL., February 5.—One of the most progressive and up-to-date talking machine dealers in this section of the country is E. Frank Winfield, proprietor of the Outing Shop, who is also a great believer in aggressive and consistent

herewith was prepared by Mr. Winfield to properly present to the people of Grand Junction the new advertising record recently introduced by the Columbia Graphophone Co. In this connection the Outing Shop certainly met with gratifying success, as the window attracted general attention and was the direct cause of several substantial record and machine sales.

It is interesting to note that the Outing Shop has achieved exceptional success with this new advertising record, considering the limited scope of its working possibilities. When this record was first introduced, Mr. Winfield had a mailing list of seventy names, to whom he mailed regularly Co-

NEW VICTROLA DEPT. IN BUFFALO

Opened in Store of Neal, Clark & Neal—Special Sound-Proof Demonstration Booths Provided.

(Special to The Talking Machine World.)

BUFFALO, N. Y., February 6.—The Victrola department of the store of Neal, Clark & Neal, at 645-649 Main street, has just opened. All the modern improvements and artistic designs are embodied in the new addition to the store, which has been located on Main street for many years. One of the features of the new department is the installation of soundproof demonstration booths, which enable the purchasers of Victrolas to hear, without interference, the machine they wish to purchase. W. J. Bruehl is manager of the new department.

MUST ABIDE BY THE CONTRACT

When the Contract Provides That the Employee Shall Satisfy the Customers of His Employer.

When a contract for employment provides that the employe shall satisfy the customers of his employer, it is sufficient to show on a trial of his suit for breach of contract that the customers were dissatisfied. The question whether they had good grounds for their dissatisfaction is not material, and any verdict predicated upon such a theory may be set aside, the Appellate Division ruled recently, sustaining the appeal of the Henry W. Boettger Silk Manufacturing Co. against a Supreme Court judgment in favor of William Messmer, a silk finisher, discharged by them. Messmer's contract provided that he should be employed while his work gave satisfaction to the company's customers. The court observed that the jury had probably been actuated by sympathy, since they gave Messmer a verdict for half of what he would have been entitled to, if entitled to anything.

PLEASING NEW YEAR'S SOUVENIR.

The International Phonograph Co., a successful Victor and Columbia dealer, with stores at 101 Essex street, and 196 East Houston street, New York, is sending out to its many patrons a very attractive 1914 calendar that should serve as a year-round reminder of the company's establishments. The calendar shows the trade-marks of both the manufacturers the company represents, together with an appropriate center illustration in several colors.

INCORPORATED.

The LaGrange Talking Machine Co., LaGrange, Ill., has been incorporated with a capital stock of \$25,000, to manufacture and deal in talking machines.

THE MAN WHO STICKS.

Look around among the men you know and observation will teach you that, in the majority of cases, the man who wins in any vocation in life is the man who sticks to it. He may be a plodder, but if he is endowed with perseverance, he may surpass the versatile or brilliant man.

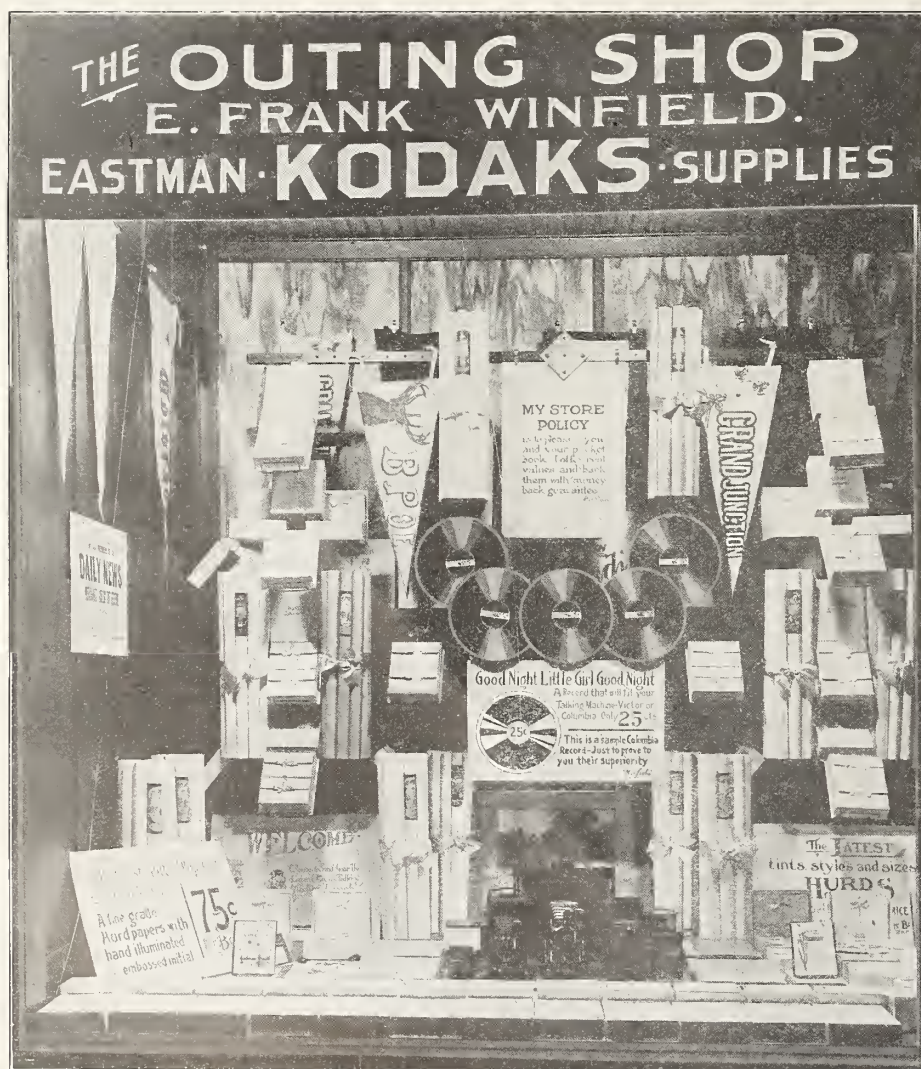

Attractive Window of the Outing Shop, Grand Junction, Col.

publicity and solicitation, regardless of the size of the city wherein his establishment may be located. Mr. Winfield handles the complete line of the Columbia Graphophone Co., in addition to doing an excellent business with Eastman cameras and photographic supplies.

The accompanying illustration of a recent window display at the Outing Shop gives a fair idea of Mr. Winfield's ideas relative to this important phase of retail merchandising. The show window

lumbia bulletins and various forms of literature. With the introduction of the advertising record, however, Mr. Winfield was enabled to increase his mailing list nearly 100 per cent., adding fifty live-wire names to his prospect file as a result of the value represented in the Columbia advertising record.

The mailing list of the store is now 120, which is an admirable one for a city of Grand Junction's size and population.

A RESULT GETTING ADVERTISEMENT.

Attractive Manner in Which Harger & Blish Exploited the Advantages of the Edison Phonographs to the Music Lovers of Des Moines—Artistic Newspaper Advertisements.

(Special to The Talking Machine World.)

DES MOINES, IOWA, February 7.—One of the most successful and result producing advertisements for the Edison phonograph ever published

cylinder and disc, offer the opportunity of having the best of the world's music brought directly to the fireside with a minimum of expense and trouble was strongly impressed upon both those who attended the Melba-Kubelik concert and those who stayed home.

PHONOGRAPH TALKED BACK.

J. B. Benton, a veteran engineer and mechanic, who was associated with Thomas A. Edison a generation ago, at the time the phonograph was just beginning to evolve as a commercial proposition, recalls, with a chuckle, the following historic incident to the memory of the "Wizard."

One of the first machines that went out of the laboratory was delivered to Charley Cheever, son of the well-known belting manufacturer. Charley couldn't make it work, and finally sent for Edison.

The great inventor himself worked over the phonograph, reciting "Mary had a little lamb" into it distinctly for nearly an hour without audible result. At last he lost patience, and slammed the thing down with a jilt, exclaiming: "Talk, d—n you! Why in blazes don't you talk?"

Then, suddenly, the phonograph broke its long silence, and squeaked out to Mr. Edison's horror:

"D—n you! Why in blazes don't you talk?"

SELL 16 VICTORS IN ONE HOUR.

This Was the Achievement of Benesch & Son, of Annapolis, Md., During a Recent Day.

(Special to The Talking Machine World.)

ANNAPOLIS, Md., January 31.—The enterprising Victor representatives in this city, Isaac Benesch & Sons, closed the best year in their history. The company maintained a consistent advertising campaign from one end of the year to the other, and this publicity, coupled with the unceasing efforts of the capable sales staff resulted in the closing of this banner year's business.

Some idea of the splendid business closed by this aggressive dealer may be gleaned from the fact that in one hour on a Saturday recently, Wm. McCurdy, manager of the store, sold sixteen Victrolas, a record to be proud of, considering the size of the city, and its population, which totals about 9,000. The company's clientele is going a pace, and judging from the record business closed so far this month, the machines sold during the past fall season are giving perfect satisfaction.

OPENS STORE IN UNION HILL, N. J.

Andrew Brunton, the prominent piano dealer with stores in Jersey City and Perth Amboy, opened recently a new store in Union Hill, N. J. Mr. Brunton is featuring in this new establishment his leaders—the Kranich & Bach and Hardman lines—in addition to several other well-known pianos and Columbia talking machines and records. Large and attractive signs are prominently displayed on the new building, calling the attention of the public to the high-grade character of the instruments handled by Mr. Brunton.

LOOK OUT FOR THIS MAN.

A man who has given various names when seeking employment, and who recently worked for the Chase & West Talking Machine Co., of Des Moines, and for another concern in Iowa, has disappeared. Wherever he has been employed, it is stated, he borrowed money, or got it under false pretenses. The last case was with Herman Marks, of Emmetsburg, Ia., where he sold a \$300 piano for \$100 cash, pocketed the money and skipped.

This man is about five feet high, weighs 110 pounds, dark brown hair, has a scar on the left side of his face from the corner of his mouth to the lower end of his cheek bone. He also has a wen about the size of a thumb nail on the side of his right ear. The Chase & West Talking Machine Co. has sent us these facts for the purpose of warning the trade. This man is supposed to have left for Chicago or Seattle.

Many a man has been undone through undue influence.



An Evening After The Concert—Thought Suggested By Harger and Blish

A Clever Edison Phonograph Advertisement.

by Harger & Blish, the prominent Edison jobbers with headquarters in this city and branch stores in Dubuque and Sioux City, is that reproduced herewith, and which occupied a full page in the Des Moines Evening Tribune on the day that Mme. Melba and Jan Kubelik gave a joint concert here.

The fact that the Edison phonographs, both

VICTOR DOG HAS A RIVAL.

Alfred W. Meldon, a lawyer of Jamaica, is reported by one of the local papers to be considering the effort of a talking machine concern to make records of songs of his dog, Caruso, which sings to the accompaniment of the piano, and is said to have a cultured voice.

IN the clinches you can rely upon the **Ditson Victor Service.** Profits are contingent upon *our fast work*—and we know it.

STOP saying to your customers: "We haven't got it," because you can get it from **DITSON.**

FAST Victor service is our aim, and that we hit the mark is proved in our rapidly growing clientele of dealers.

ALL Victor Styles, records and parts, with a complete line of albums, cabinets and needles.

WE specialize upon Victor goods exclusively, and correspondence with dealers desiring the best in Victor service is invited.

Oliver Ditson Company,

Boston, Mass.



The Tango and Columbia Records are linked in the public's mind. Swing this public into your store by advertising Columbia Dance Records.



(Write for "Music Money," a book "full of meat" for those dealers interested in quick and frequent turnover of capital.)

Columbia Graphophone Company
Woolworth Building, New York

INTRODUCING THE ARTIST TO THE CUSTOMER.

A Series of Receptions Held at Your Store, Mr. Dealer, Where the Talent Meets Your Patrons Socially, Will Prove the Greatest Tonic Ever Prescribed for a Languid Business—It Will Make Weak Trade Strong and Strong Trade Stronger.

Have you ever noticed, Mr. Talker Man, when a prominent phonograph artist, who is also popular upon the stage, plays an engagement at a theater near your store, how it facilitates the sale of that particular artist's records? To illustrate: While Harry Lauder was playing in Philadelphia a short time ago the talker shops in that city were besieged with orders for his selections, the greatest demand centering naturally upon the songs he sang at his concerts. Even now, a full week after Mr. Lauder's Philadelphia engagement, I find, on glancing through my daily paper, that Louis Buehn is still interested in the event as a trade stimulant. In a conspicuous advertisement bearing the title, "You Missed Hearing Harry Lauder? But you may still hear him any time you like; the Victor makes it possible," he publishes a list of thirty-seven records made by this great entertainer.

Now then: If the mere proximity of the artist to your establishment will boost sales several hundred per cent., why not go further and arrange for a series of receptions where the talent will come in personal contact with the customer upon a social basis.

It appears to the writer that the manufacturer might be induced to meet the dealer half way in this matter, it being mutually advantageous. It could be arranged between the manufacturer and the artist, at the signing of their contract that a series of receptions be held at the stores of various dealers, and provisions for the same incorporated in that document. These affairs could be given, in a great many instances, very easily and inexpensively for this reason: A large proportion of the talent are en route during a part of the year upon concert, operatic or vaudeville tours, and their itinerary could be furnished in advance to the talking machine men along their line of march, so that the artists' professional and social engagements in a certain town might take place simultaneously.

When we pause to consider the vast sums—in some cases reaching six figures—spent annually by the makers of talking machines in advertising their wares, the matter of artists' receptions seems small in a financial sense, even though the entire burden be borne by the manufacturer. Inasmuch as the artist is already well paid for his record making, he should see that getting in personal touch with his phonographic audience cannot but have the effect of increasing the demand for his services, thereby adding to his already substantial remuneration. This being the case, he should carry out the reception idea with enthusiasm and be willing to accept a modest return in dollars and cents for his services in this field.

It would be as well at first, perhaps, to introduce the talent whose voices have been familiar to the users of phonographs for a great many years. Whom among all your customers would not be among those present were Messrs. Collins, Harlan,

Hooley or Stewart announced to meet them at your salesrooms? The "standing room only" sign would be conspicuously displayed, I am sure. Of course, it would add very materially to the success of the occasion to have a piano and accompanist in attendance in order that those who had heard Messrs. Collins, Harlan, Hooley and Stewart perform phonographically for fifteen years could have the pleasure of hearing them at least once in the flesh; but even though a pleasant word and a hearty hand clasp were the only numbers upon the program, the event would still be a huge success from a trade-stimulating standpoint, and the demand for coon duets, basso solos and Yankee stories would aviate.

Our old friend Cal would, I think, be the gentleman to introduce the reception idea, for who is there, from the snow-clad hills of Maine to the sun-kissed groves of Florida, or even to the shores of the balmy Pacific, that has not heard the quaint Yankee drollery of Uncle Josh Weathersby? A long time ago—fourteen years, perhaps—Uncle Josh appeared in the guise of host and entertainer at a Philadelphia talker shop, and he was welcomed by several hundred phonographists with open arms and gusts of merriment. I know, for I was there.

As I write, there is one incident in connection with that Stewart reception that remains fresh in my memory through the years.

Cal had just finished telling a story, which at that time had not been recorded, in reference to an aching molar.

"I went into one of them there tooth distractin' parlors," he explained, with the laugh that is his and his alone, an' the feller asked me if I'd take gas. I told him that up at Punkin Center where I come from we didn't know much about gas, an' if 'twas all the same to him, I'd take kerosene."

The laughter was still surging through the room as a result of this bit of rare humor when an elderly Quaker lady, in a sugar-scoop bonnet, asked meekly but curiously, "Calvin, does thee sing?"

"Gosh all hemlock, madam!" replied Mr. Stewart, mournfully, "I couldn't carry a tune if I had it in a satchel."

Just why the artist reception idea did not bear fruit at that time, I am not prepared to say, but this much is certain: A proposition attended by abundant success fourteen years ago and lying dormant from that time to the present day, if handled with the snap and vim that characterizes modern business methods, cannot but succeed mag-

nificently. In conclusion, Mr. Dealer, we will indulge in a brief resumé of just what this artist reception idea means to you.

Let us suppose that the theory has been put in practice, and you have received word from your manufacturer that Cal Stewart will hold a reception at your store for the benefit of your patrons on the twenty-fifth of February. You immediately send out announcement cards bearing a half-tone cut of Mr. Stewart and worded thus:

"You are cordially invited to be present at a reception given by Mr. Cal Stewart to his phonographic friends at the salesrooms of the Elite Talker Shop on Wednesday, February twenty-fifth, at three."

Upon the occasion of the reception you have your store attractively decorated with potted plants, an adequate number of easy chairs placed invitingly, a great deal of literature pertaining to all your goods in general, and the Josh Weathersby records in particular, displayed within easy reach of your guests—and I think that is all.

Necessarily, your show window should cry aloud to the housetops for at least one week previous to the reception that the premier delineator of the way down East type of rural citizen is to hold forth within, the decorations consisting of a large portrait surrounded by a tastefully arranged assortment of agricultural accessories, etc.

The setting thus ably prepared, the reception follows. Mr. Stewart is introduced, chats with your patrons, tells a few yarns no one has heard before and suggests certain of his records as being particularly attractive. Then refreshments are served while orders for Uncle Josh records are taken, and the show is over.

Very little trouble, small financial outlay, and big returns. In fact, everything may seem diminutive, but Cal, the crowd and the profits, which is as it should be.

HOWARD TAYLOR MIDDLETON.

VISITING SWITZERLAND FACTORY.

Marc K. Mermod, of Mermod & Co., 505 Fifth avenue, New York, manufacturers of supplies for talking machine makers, is now at the Switzerland factory for a few weeks' visit, getting his line of goods ready to take with him on the trip that he is planning to make through China.

E. L. Cuendet, a man well experienced in the importing line, and also the talking machine business, is now in charge of the New York offices, where visiting manufacturers may see him.

Many people confuse the term "efficiency with the word "effectiveness," and while there is a current usage in which the two terms overlap, yet the difference is easily capable of detection, and it is important too.

CHEMISCHE FABRIK **E. SAUERLANDT** bei FLURSTEDT
The largest manufacturing plant in the world devoted exclusively to the
manufacture of Master-Waxes and Master-Blanks for
Gramophone and Phonograph Recording
Sole Manufacturer of Wax "P." the best recording material for Berliner-cut.

HANDSOME TALKING MACHINE QUARTERS IN EL PASO

Conducted by the Southwestern Talking Machine Co. in That Go-ahead City—Now Controlled by Rafael Cabanas, President of the Mexican Phonograph Co.

(Special to The Talking Machine World.)

EL PASO, TEXAS, February 8.—The accompanying illustration, showing the main floor of the Southwestern Talking Machine Co.'s headquarters in this city, gives a fair indication of the up-to-date ideas of this hustling Columbia representative. Sound-proof demonstration booths furnished

Columbia Graphophone Co. Raphael Cabanas, president of the Mexican Phonograph Co., and an ardent Columbia admirer, is at the head of the new company, while Robert R. Souders is general manager with headquarters in Dallas. J. M. Spain, who is well-versed in Columbia selling details, is in charge of the local store.



in a dignified and refined manner are included in the artistic appearance of the company's warehouses, which are tasteful and refined to a degree.

The Southwestern Talking Machine Co. is the new name of the company, which recently purchased the Dallas and El Paso stores of the Co-

The El Paso store of the Southwestern Talking Machine Co. is located at the corner of Stanton and Texas streets, one of the best spots in the business section of the city. During 1913 the store closed an excellent business, which bids fair to be exceeded month by month during the ensuing year.

VICTOR LINE FOR HALLET & DAVIS.

This Line to Be Presented in Pleasing Environment in New Forty-second Street Store of the Hallet & Davis Co. in New York.

Arthur D. Geissler, vice-president of the New York Talking Machine Co., 81 Chambers street, New York, the prominent Victor distributor, in a chat with The World recently stated that Hallet & Davis Piano Co., one of the best-known piano houses in the country, will carry a complete line of Victor products in its attractive building at 18 East Forty-second street, New York. Hallet & Davis already handle the Victor line in their Harlem store, and the excellent results they achieved in this uptown branch prompted their decision to handle the Victor products in their new building.

When the Victor line is installed in the Forty-second street building there will be constructed several attractively furnished demonstration booths on the main floor, which will display the Victrolas to excellent advantage. There will also be constructed in the basement of the building a number of record-demonstration rooms which will be furnished and decorated to completely harmonize with the prestige of the store and the Victor line.

FIRE CAUSES \$4,200 DAMAGE

To the Stock of Pianos and Talking Machines of the Bates Music Co. in Greeley, Colo.

(Special to The Talking Machine World.)

GREELEY, COLO., February 4.—In a fire which swept through the Unity building, at Ninth street and Ninth avenue, this city, recently, the stock of the Bates Music Co., in a store on the ground floor of the building, was damaged by smoke, heat and water to the extent of about \$4,200. Over a half dozen pianos were badly wrecked and a new consignment of Victrolas and Grafonolas were damaged beyond repair. Several hundred talking machine records were damaged.

The Imperial Phonograph Co. has been organized at Portland, Me., with a capital of \$50,000. The officers of the new corporation are as follows: Hiram Knowlton, president; W. J. Knowlton, treasurer; Hiram Knowlton, W. J. Knowlton and Bertha B. Huston, directors.

DANCE RECORDS IN GREAT DEMAND.

The Present Craze for Dances Throughout the Country Exemplified in the Demand for Records, Which is Really Exceeding the Supply—Interesting Chat with V. W. Moody.

Referring to the present demand for dance records, V. W. Moody, sales manager of the New York Talking Machine Co., 81 Chambers street, New York, the prominent Victor distributor remarked as follows: "Many people have expressed their doubts as to the real status of the dance craze and have asserted that the demand for this type of music is not nearly as pronounced as the newspaper, talking machine record manufacturers and sheet music publishers would have us believe.

"As a matter of fact, however, the actual call for dance music is greatly in excess of the apparent demand for this class of record. In all sections of the country, the dance craze is gaining rapidly in popularity, and judging from the reports of Victor distributors throughout the West and South, Victor dealers are reaping a harvest in the sales of these records.

"In actual figures, the dance record sales in our own establishment are almost unbelievable. Taking as a basis of comparison the sales of one of the most popular records in 1908, our total sales this month of one dance record in the Victor library would equal a little more than 100 times the sales of the 1908 popular favorite. This figure furnishes the best possible evidence of the extent of the dance record business, and in my opinion will probably be distanced very materially in the very near future."

The New York Talking Machine Co. is devoting a considerable portion of its window space to a number of attractive dance record cut-out displays, which call attention to the most popular records of this type in the Victor library. These displays are also being used to excellent advantage by the company's dealers, who report a number of sales as a direct result of these suggestions to passers-by.

BIG TALKING PICTURE CO. FORMED.

(Special to The Talking Machine World.)

DOVER, DEL., February 5.—The Talking Machine Film Co. of America, with capital of \$2,500,000, has been chartered here. The incorporators are E. J. Forhan, F. B. Knowlton and D. A. Cassin, all of New York. The incorporation papers say the concern will manufacture, buy, sell and deal in films, photographs and other reproductions of scenes and dramas.

NEW LIST OF EDISON DISC RECORDS

Contain Many Numbers That Promise to Win a Large Degree of Favor.

Thomas A. Edison, Inc., Orange, N. J., has just issued a January supplement of Edison disc records that makes a valuable addition to the disc library. Over forty double-disc records are presented in this supplemental list, many of which are among the popular hits of the day.

Edison disc dealers in all parts of the country write to state that the new list is being received with popular favor wherever it is introduced; owners of Edison disc phonographs are availing themselves of this opportunity to considerably enlarge their record library.

Special

Send for a package of our Improved Half-Tone and Loud Tone Needles in New Style Envelopes.

If you want to advertise yourself, we will put your own name or trade-mark on the envelopes, or will pack in Puritone envelopes.

Quality Guaranteed

The Best Needles mean profit and satisfaction.

If you want to sell 1,000 Needles at a time instead of 100, use the "Dean-packed" Needles. Five boxes of 200 each, Extra Loud, Loud, Opera, Medium and Soft packed in a carton. The best package and fastest seller on the market. Write for samples.

JOHN M. DEAN, CORP.

Talking Machine Needle Manufacturers

PUTNAM, CONN.

LATEST PATENTS RELATING TO TALKING MACHINES AND RECORDS

(Special to The Talking Machine World.)

WASHINGTON, D. C., February 8.—PHONOGRAPH REPRODUCER.—Achille Luciano, Bloomfield, N. J., assignor to the Nightingale Reproducer Co., Newark, N. J. Patent No. 1,080,839.

This invention relates to an improved gramophone reproducer and is of the type that is arranged with the sound box vertical to the record and is adapted for use with its stylus projecting in substantially the same plane as the diaphragm and having its stylus adapted to be moved transversely by the groove so as to transmit its vibrations directly to the diaphragm.

The reproducer comprises a sound box in which the diaphragm is mounted in any usual manner, the stylus rod being pivoted by means of a pivotal connection that permits a limited transverse movement at the pivotal point, the stylus rod thus rocking normally at its pivotal point, but yielding to an extent under undue strain in a transverse direction.

The invention also resides in the stylus, which is mounted on the end of the rod, and which submits successive portions of its periphery to the groove whereby the groove is not subjected to undue wear and the friction is minimized, while the sound reproduction is not impaired.

Fig. 1 is a front view of the improved stylus, and Fig. 2 is a vertical section of the same through the center, the pivotal post being shown in elevation.

DISC TALKING MACHINE.—Rezso Prcsster, Budapest, Austria-Hungary. Patent No. 1,076,643. The object of this invention is to obviate the necessity of employing a trumpet with disc talking machines.

It is well known that sound trumpets generally used affect the purity of the sound and make the machine more difficult to handle and to transport. It was already proposed to cover the trumpet of talking machines or to conduct it through the casing of the machine. Thereby the trumpet was only disguised, but substantially maintained so that the sound effect was not improved by this way. As on the other hand the dimensions of the casing should not be increased too far, the dimensions of the trumpet were reduced, whereby the sound

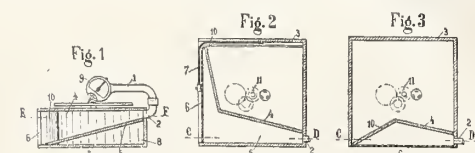

strength was decreased. But as the dimensions of the trumpet could not be decreased too far, the dimensions of the casing resulted larger than the usual casings of talking machines.

This invention does away completely with the usual trumpets without increasing the usual dimensions of the casing. According to the disclosed embodiments of this invention the free space of the casing containing the gear is subdivided by means of resonance boards in a way to form laterally from the gear a sound chamber of substantially the shape of pyramid and to form adjacent resonance boxes.

The annexed drawing shows as examples two embodiments of the invention. Fig. 1 is a diagrammatic vertical section of the machine according to line C—C of Fig. 2. Fig. 2 is a horizontal section according to line E—F of Fig. 1 and Fig. 3 is a similar section of a modified form.

SOUNDBOX FOR TALKING MACHINES.—Wilburn N. Dennison, Merchantville, N. J., assignor to the Victor Talking Machine Co., Camden, N. J. Patent No. 1,084,319.

This invention relates more particularly to

pneumatic soundboxes for talking machines and includes improvements in which a valve is provided, the movable member of which is positioned within and very close to the soundbox casing so that the air passing through the valve is caught or trapped between the movable member and the casing to cushion or balance the movable member.

The main objects of this invention are: to provide in a pneumatic soundbox a valve having a movable member of delicate construction which will respond readily to the vibrations of the stylus bar and which will be cushioned or balanced by the air passing through the valve; to provide an improved mounting for the stylus bar and the movable member of the valve, whereby the valve may be adjusted with great accuracy and whereby the balancing effect of the air after it has passed through the valve will not be impaired; to provide adjustable means for holding and tensioning the movable member upon its mounting; to provide a improved form of opening through the valve to permit the air to pass freely therethrough.

In the accompanying drawings, Figure 1 is a fragmentary front end view of a soundbox constructed in accordance with this invention; Fig.

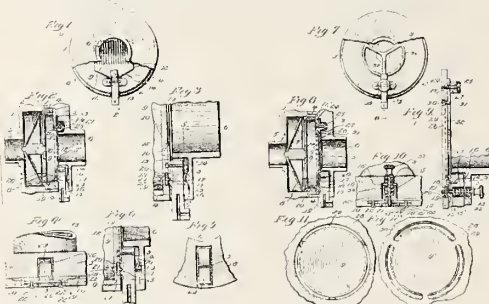

2 a longitudinal section on line 2—2 of Fig. 1; Fig. 3 an enlargement of a portion of Fig. 2; Fig. 4 an enlarged fragmentary sectional view on line 4—4 of Fig. 1; Fig. 5 a fragmentary sectional view on line 5—5 of Fig. 3; Fig. 6 a fragmentary sectional view corresponding to Fig. 3 showing a modification of the invention; Fig. 7 a view corresponding to Fig. 1 of a modified form of this invention; Fig. 8 a longitudinal section view taken on line 8—8 of Fig. 7, parts thereof being omitted; Fig. 9 an enlarged fragmentary longitudinal central sectional view of the soundbox shown in Figs. 7 and 8; Fig. 10 a transverse sectional view of the soundbox shown in Fig. 9; and Figs. 11 and 12 are enlarged fragmentary front and rear elevations respectively of the valve seat shown in Figs. 7 to 9.

SOUNDBOX AND REPRODUCTION THEREOF.—Victor H. Emerson, New York, assignor to the American Graphophone Co., Bridgeport, Conn., Patent No. 1,084,415.

This invention relates to sound record having laterally undulating record groove of substantially uniform depth, commonly known as "zigzag" records. The object of the invention is to produce a record of this type which will have improved acoustical qualities. Such "zigzag" records are commonly manufactured as discs with the record groove arranged spirally around the cylinder; yet, for convenience of consideration, such record groove may be regarded as continuing in a straight line, with the lateral undulations on either side.

The underlying thought of this invention is to provide a (zigzag) record groove of such character as to produce a duplication or immediate repetition of each impulse imparted to the reproducing stylus, so that theoretically there should be expected a sort of "echo" as it were; yet in actual practice no echo will be observed by the listener, but merely increased fulness or roundness of tone. This duplication or repetition is accomplished by making the original record by means of a recording stylus having its two oppositely extending recording edges disposed diagonally with respect to the direction of

travel of the record groove (instead of transversely thereof as heretofore). As the result of this arrangement of one recording edge is slightly advanced in front of the other, and each concavity produced in one side wall of the record groove will have its complementary (and simultaneously produced) convexity located diagonally therefrom in the opposite wall of the groove (instead of directly across therefrom).

This invention, then, consists broadly in providing a diagonally disposed pair of oppositely facing recording edges for making the original sound groove; further, in the simultaneous production of diagonally disposed and complementary concavities and convexities corresponding to sound waves;

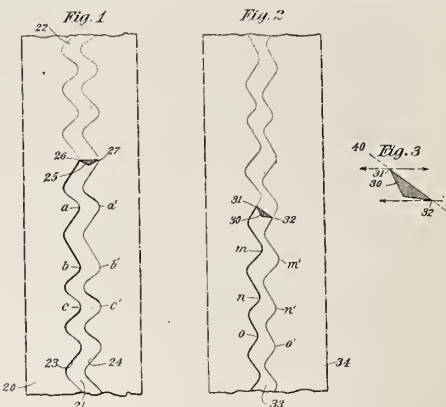

and also in a sound record having such diagonal arrangement of its complementary concavities and convexities.

This invention will be best understood by reference to the annexed drawings, which are on a greatly exaggerated scale, to illustrate the same diagrammatically.

In these drawings: Fig. 1 represents conventionally a plan of a portion of a flat record tablet having an ordinary zigzag record groove, and indicating in cross section an ordinary recording stylus. Fig. 2 is a similar view, indicating the new record groove, and indicating in cross-section the new recording stylus; and Fig. 3 is a horizontal section, on a still larger scale, of the stylus.

CLARIFYING ATTACHMENT FOR TALKING MACHINES.—Walter J. Burchett, East Orange, N. J., assignor by mesne assignment to the Masterphone Corporation, New York. Patent No. 1,084,570.

This invention relates to clarifying attachments for talking machines, and constitutes an improvement on the general type of apparatus illustrated in the pending application of Matthew B. Claussen, Serial No. 779,004, renewed July 14, 1913.

This object is the provision of a simple, inexpensive and durable attachment which can be quickly and easily applied to or removed from the reproducer of a talking machine, particularly one of the disc type, which will increase the volume of sound, clarify the tone, and enable a needle of small diameter to be used in sound reproduction, thereby increasing the life of the record, and these objects are accomplished by substituting a less rigid connection between the needle of the standard

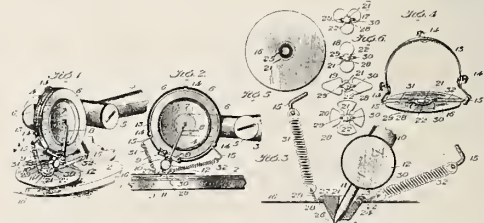

talking machine reproducer, and the thin, freely vibrating sound amplifying body or disc of the said Claussen application than is employed in the specific form of construction illustrated in said Claussen application, and supplementing the engagement between the needle and disc by a second, elastic connection between other parts of the reproducer and the disc, whereby the disc is held against the needle with sufficient firmness to absorb the vibrations thereof when the reproducer is in operation, but may yet be easily removed from contact with the needle (when the latter is to be removed from the reproducer), without entirely disconnecting the disc from the reproducer as a whole

In the accompanying drawings and following description, is shown a form of the invention illustrating its mode of operation and which carries out the foregoing objects, but such disclosure is to be considered as illustrative, rather than restrictive, of the scope of the invention and the invention is susceptible of modification without departing from the spirit and scope thereof.

In the accompanying drawings: Fig. 1 is a perspective view showing the invention applied to an ordinary talking machine reproducer and disc record; Fig. 2, a side elevation thereof; Fig. 3, an enlarged detail, partly in section, showing the co-operation of the device with the needle; Fig. 4, a detail perspective of the attachment alone; Fig. 5, a view looking toward the lower face of the thin, freely vibrating sheet or disc; and Fig. 6, detail plan views of other shapes of thin, freely vibrating sheet or disc that may be used.

TALKING MACHINE.—Matthew B. Claussen, New York, assignor by mesne assignments to the Masterphone Corporation, New York. Patent No. 1,084,571.

This invention relates to the reproducing apparatus of talking machines and comprises a modification of the invention illustrated and described in my pending application Serial No. 670,146, filed January 9, 1912.

The present apparatus is designed especially to co-operate with records having grooves of uneven depth, the sound waves being recorded in the bottom of said grooves instead of in the sides of said grooves.

The best form of apparatus embodying the present invention, together with certain modifications thereof, are shown in the accompanying sheet of drawings in which, Fig. 1 is a vertical central section of a soundbox adapted for use on cylindrical

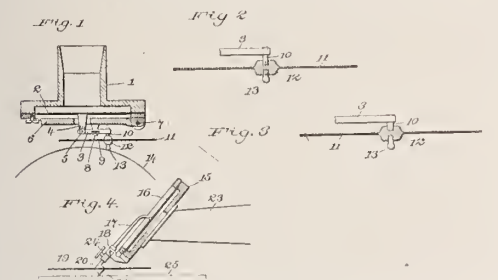

al sound records. Fig. 2 is an enlarged detail cross section of the disc which forms the novel feature of the invention. Fig. 3 is a similar view of a modification, and Fig. 4 shows the modification adapted for use on disc records having grooves of uneven depth.

TALKING MACHINE.—Matthew B. Claussen, New York, assignor by mesne assignments to the Masterphone Corporation, New York. Patent No. 1,084,572.

This invention relates to improvements on the particular form of attachment to talking machines illustrated and described in application Serial No. 670,146, filed January 9, 1912, in which is shown a thin sound amplifying disc rigidly mounted on the stylus of the reproducer of a talking machine. In the one particular form of the invention selected for illustration in said prior application the reproducing needle is clamped into the socket on the end of the stylus arm in the usual way, and the disc is held on the needle by being bored to form an opening of an internal diameter equal to or slightly less than the external diameter of the needle. This requires the needle to be forced through the disc before using, and, as it is not safe to use a needle on more than one record, it is necessary to pull the needle out of the disc every time a new record is put on, and stick a new needle through the disc before fastening the needle to the stylus arm for the next operation of the machine. While this can easily be done with a small pair of tweezers, the entire operation can be avoided by the use of the present invention, which comprises means for permanently attaching the disc to the stylus arm, and means for mounting the needle in this attaching means by any simple device such as a set screw. Consequently when a needle is worn it can be loosened from the disc, removed and a new one fastened to the disc without unfastening the disc from the reproducer.

The drawing shows a vertical central section of the preferred form of apparatus embodying the invention.

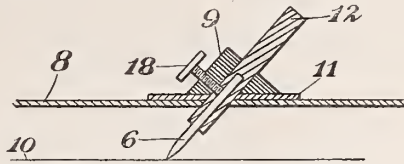

TALKING MACHINE.—Matthew B. Claussen, New York, assignor by mesne assignments to the Masterphone Corporation, New York. Patent No. 1,084,573.

This invention relates to talking or sound reproducing machines in which a stylus travels in a groove in a tablet or cylinder having variations of surface corresponding to sound waves. It is well known that in apparatus of this kind heretofore in use the loudness of reproduction may be increased by increasing the stiffness of the reproducing stylus, as by making said stylus of greater cross-section, but this results in a disadvantage in that the reproduction is then less clear and faithful. On the other hand it is recognized that the clearness, delicacy and faithfulness of the repro-

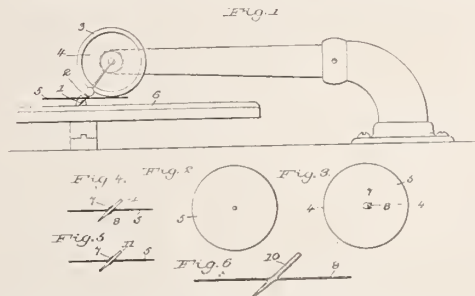

duction may be enhanced by making the reproducing stylus light, as by reducing its cross-section, but this reduces the volume of sound.

The inventor has discovered an improvement which may be applied to any of the standard forms of talking machine by which both the volume and clearness, or faithfulness, of the sound reproduction, are markedly increased and improved.

Briefly stated, this invention in its simplest form comprises the rigid attachment of a disc of convenient form to the standard form of reproducing stylus or needle.

Fig. 1 is a side elevation of a portion of a talking machine showing the reproducer with invention attached. Fig. 2 is a plan view of the simplest form of disc attachment constituting the novel element of the invention. Fig. 3 is a similar view of a modification. Fig. 4 is a vertical central section on line 4-4 of Fig. 3 showing also the reproducer stylus or needle in position. Fig. 5 is a similar view with a different kind of stylus, and Fig. 6 is a similar view of a modification.

SOUNDBOX ARM FOR TALKING MACHINES.—William W. Zackey, Philadelphia, Pa., assignor of forty-nine one-hundredths to Chas. B. Hewitt, Burlington, N. J. Patent No. 1,083,045.

This invention relates to the sound amplifying devices and has for an object to provide an amplifying arm and horn which are capable of transmitting and reproducing the sound with a minimum of variation from the original.

It has for a further object to provide a novel means of eliminating the scratching and scraping noises which are produced by movements of the sound record or irregularities in its surface. To this end a construction has been devised wherein the amplifying arm is maintained substantially in equilib-

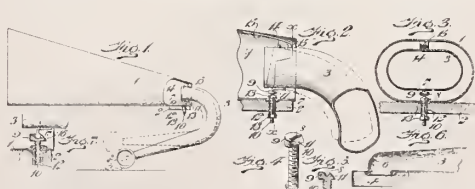

rium, or floating condition, above the record but is so adjusted and arranged as to permit an extremely sensitive action of the needle with respect to the record.

Fig. 1 represents a side elevation of a sound

reproducing device, embodying the invention, the same being shown partly in section. Fig. 2 represents an enlarged section of a portion of the device. Fig. 3 represents a section of line x-x, of Fig. 2. Fig. 4 represents a perspective of the supporting device for the sound arm. Fig. 5 represents a section of a portion of the same. Fig. 6 represents a section of a portion of the sound arm showing its connection to the soundbox. Fig. 7 represents a section of a modified form of the device.

SOUNDBOX.—Peter J. Mukautz, Chicago, Ill. Patent No. 1,085,354.

This invention relates to improvements in soundboxes for use in connection with sound recording or reproducing machines.

The principal object of the invention is to provide a soundbox, which will so actuate the needle or stylus as it travels over the surface of the record, that clean-cut, smooth grooves will be traced therein; and in reproducing said record, the tones obtained will be intensified, clear and free from harsh or grating sounds. This is accomplished

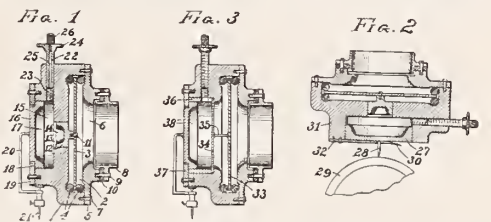

by confining air or a liquid between a pair of oppositely arranged cupped pistons of different diameters.

Another object of this invention is to provide means for regulating the air or liquid pressure between the pistons, in order to get the best results from the soundbox either in making a record or reproducing the same.

In the drawings, Fig. 1 is a sectional elevation of a soundbox constructed in accordance with the invention, for use in connection with a laterally undulating record groove machine. Fig. 2 is a similar view showing a soundbox for an up-and-down record groove machine, and Fig. 3 illustrates a modification of Fig. 1.

BUYING AND SELLING POINTERS.

Buy with one end in view, to sell.

But remember, to sell means more than one sale. Therefore keep an eye open for quality, as well as price.

Buy as near home as possible. You will gain in time of delivery and in price as well.

If you are to sell, it will be necessary to buy. But remember that the selling depends largely on the buying.

Buy with both eyes wide open. Then when you sell you won't fear to meet the steady gaze of your customer.

The man who buys goods without taking selling into consideration reminds one of Br'er Rabbit and his experience with Tar Baby.

Don't treat your jobber as if you distrusted him. Remember he is probably as anxious to hold your trade as you are to keep one of your customers.

If you have a call for something you haven't got, and it's in your line, get it. But don't buy a gross unless you have more than one call for the article.

The merchant who buys, without first studying his local market, is like a traveler without a map; he is likely to end his journey at the wrong destination.

Buy early so that you can display the goods just before the season opens, thus securing the first orders, and also the reputation of being the leader in your lines.

Buy with due regard for the taste of your patrons. Cater to the trade of the "upper ten," but don't forget that the "lower" ten thousand are the people who spend the greater volume of money annually.

No honest purpose is ever wasted and no honest desire ever remains unanswered.

Many a man's best friends are those who know him least.

RECORD BULLETINS FOR MARCH, 1914

COLUMBIA GRAPHOPHONE CO.

SYMPHONY DOUBLE-DISC RECORDS.
First Records by Maggie Teyte, the English Soprano.

No. Title. Size
A1471 A Resolve (Obstination) (de Fontenailles). In English, with orch. 10
An Open Secret (Woodman). In English, with orch. 10
A1472 Little Gray Home in the West (Lohr). In English, with orch. 10
When Love is Kind (Old Melody). In English, with orch. 10
Two Records by Bernice de Pasquali.
A5523 Lakme (Delibes) "Dove l'Indiana bruna" (Indian Bell Song—Where goes the Young Hindoo?) In Italian, with orch. Single record is No. 30951 12
Il Guarany (Gomes) "Clara una volta un principe" (A Prince There Was). In Italian, with orch. Single record No. 36810 12
Concert Numbers by Charles W. Clark.
A1470 Thy Beaming Eyes (MacDowell). Orch. accomp. 12
An Irish Folk-Song (Foot). Orch. accomp. 12
Morgan Kingston Sings Two Songs.
A5527 The Rosary (Nevin). Orch. accomp. 12
For You Alone (Goohl). Orch. accomp. 12

BLUE-LABEL DOUBLE-DISC RECORDS.
First Recordings by Edgar Donovan, Boy-Soprano Soloist of Grace Church, New York.

A1478 Florian's Song (Godard). Orch. accomp. 10
The Swallow's (Cowen). Orch. accomp. 10
A1468 You're Just as Sweet at Sixty as You were at Sweet Sixteen (Helf). Will Oakland, Counter-Tenor, orch. accomp. 10
Emmet's Lullaby (Emmet). Will Oakland, counter-Tenor, orch. accomp. 10
A1473 Impromptu-Opus 29 (Chopin). Leo Ornstein, Pianist. 10
Etude in G Flat, Opus 10, No. 5 ("Black Key" Etude) (Chopin). Leo Ornstein, Pianist. 10
A1475 Rockin' in the Wind (Neidlinger). Columbia Ladies' Quartet 10
Little Alabama Coon (Starr). Columbia Ladies' Quartet 10
A1476 Alice, Where Art Thou? (Ascher). Reed Miller, Tenor and Frank Croxton, Baritone, orch. accomp. 10
Love's Golden Dream (Lennox). Clara Moister, Contralto, orch. accomp. 10
A5529 Fra Diavolo (Auber). Vocal gems. Columbia Light Opera Co., orch. accomp. 12
Fra Diavolo (Auber). Selections. Prince's Orch. 12
A5530 Tannhauser (Wagner). Pilgrim's Chorus. Columbia Opera Chorus. 12
Die Meistersinger (Wagner)—Selection. Prince's Orchestra. 12

DOUBLE-DISC RECORDS.
A1469 The Sweetest Flower that Blows (Hawley) Cornet Solo. Charles Leggett 10
In this Hour of Softened Splendor (Pinsuti). St. Hilda Colliery Band 10
A1474 Miss McLeod's Reel. Prince's Orchestra 10
The Irish Washerwoman. Prince's Orchestra 10
A1477 Danube Waves (Iavonici). Accordion Solo. Pietro Deiro 10
The Return (Diero). Accordion Solo. Pietro Deiro 10
A5528 Nocturne (D'Ambrosio). Cristeta Goni, Violinist Andante (Hollman). Hans Kronold, "Cellist 12

THE LATEST DANCE RECORDS.
Supervised and Approved by G. Hepburn Wilson.

A5532 International Rag (Berlin)—One-step. Prince's Band 12
Waltz—Hesitation, from "High Jinks" (Friml). Prince's Band 12
A5531 Puppchen (Gilbert)—One-step. Prince's Band 12
Y Come la Va (Valverde)—Tango. Prince's Band 12
A1460 Answer to "Amoureuse" (Berger)—Boston Hesitation Waltz. Municipal Band 10
Love's Tears (Miguel)—Boston Hesitation Waltz. Municipal Band 10
A1461 Rose River (Alvarado)—Boston Hesitation Waltz. Municipal Band 10
Path of Roses (de Paz)—Boston Hesitation Waltz. Municipal Band 10
A1462 Mena, Take My Arm "Prendete del Brazo Mena" (Villoldo)—Tango. Municipal Band 10
Flash of Fire "El Fognazo" (Villoldo)—Tango. Municipal Band 10
A1463 A Good Fellow "Un Mozo Bien"—Tango Matchiche (Villoldo).—Tango. Municipal Band 10
Tangolette (La Tangochinette) Tango Matchiche (Villoldo).—Tango. Municipal Band 10
A1464 The Aeroplane (En Aeroplano) (Prince).Tango. Municipal Band 10
Beautiful Portenitas (Lindas Portenitas) (Prince)—Tango. Municipal Band 10
A1465 El Ladio (Gobbi)—Tango. Municipal Band 10
Pasate el Paine (Gobbi)—Tango. Municipal Band 10
A1466 Auxilio (Bassi)—Tango. Municipal Band 10
El Chichon (Villoldo)—Tango. Municipal Band 10
A1467 El Sanducero (Gobbi)—Tango. Municipal Band 10
To My Manis "A Mi Manis" (Gobbi)—Tango. Municipal Band 10

SONG HITS FOR MARCH.

A1484 I'm on My Way to Mandalay (Fisher). Henry Burr, 1st Tenor; Albert Campbell, 2d Tenor; orch. accomp. 10
While They Were Dancing Around (Monaco). Ed. Morton, Baritone, orch. accomp. 10
A1483 Rebecca of Sunnybrook Farm (Gumble). Helen Clark, Mezzo-Soprano and Irving Gillette, Tenor, orch. accomp. 10
In the Candle Light (Brown). Nora Watson, Contralto, and James F. Harrison, Baritone, orch. accomp. 10
A1481 All Aboard for Dixie, from "High-Jinks" (Friml). Ada Jones, Soprano, and Peerless Quartet, orch. accomp. 10
High-Jinks, from "High-Jinks" (Friml). Charles W. Harrison, Tenor, and Mixed Quartet. 10
A1480 Across the Great Divide (Meyer). Henry Burr, Tenor, and Andrea Sarto, Baritone, orch. accomp. 10
By the Old Wishing Well (Sherman). Henry Burr, Tenor, and Albert Campbell, Tenor, orch. accomp. 10
A1482 Let's All Go Around to Mary Ann's (Carroll). Arthur Collins, Baritone, and Byron G. Harlan, Tenor, orch. accomp. 10
Don't Stop (H. Von Tilzer). Peerless Quartet, orch. accomp. 10
A1479 Sit Down, You're Rocking the Boat (Schwartz). William Halley, Baritone, orch. accomp. 10

Stop Thief (A. Von Tilzer). William Halley, Baritone, orch. accomp. 10

VICTOR TALKING MACHINE CO.

POPULAR SONGS.

No. Title. Size
17494 Dinah—(Murphy-Marshall). Peerless Quartet Let Me Change Your Name, Miss Mandy (Dawson-Engel). Collins-Harlan 10
17496 Somebody Else is Crazy 'Bout Me (Carroll). Helen Clark-Billy Murray 10
When You Haven't a Beautiful Girl (Clarke-Morse). Albert Campbell-Henry Burr 10
17497 Honey, You Were Made for Me, from "All Aboard" (Glogau). Campbell-Burr 10
Come, My Honey, Come (Sinnott-Wilkins). Peerless Quartet 10
17518 Sing, Rock-a-Bye Baby to Me (Kirkpatrick-Long). Will Oakland 10
Ealyne (Paul Dresser). W. Oakland-B. Murray 10
17519 My Orchard is Short of a Peach Like You (Nye-A. Von Tilzer). Ada Jones-Billy Murray 10
Daddy, Come Home (Irving Berlin). Billy Murray 10
17527 Down in Chattanooga (Irving Berlin). Collins and Harlan 10
When You're All Dressed Up and No Place to Go from the "Beauty Shop" (Hein). Billy Murray 10
17529 In the Candle Light (Fleta Jan Brown). Edna Brown-James F. Harrison 10
Sweet Anna Marie (Estrom-Morse). Albert Campbell-Henry Burr 10
17535 All Aboard for Dixieland, from "High-Jinks" (Cobb). American Quartet 10
Ragtime Dream (Goodwin-Brown). Am. Quartet 10

NEW DANCE RECORDS.

35362 Peg o' My Heart—One-step or Turkey Trot (Fred Fischer). Victor Military Band 12
The Horse Trot—One-step or Turkey Trot (Uriel Davis). Victor Military Band 12
17530 Pepper Pot—One-step or Turkey Trot (Harold Ivers). Victor Military Band 10
Antipolo—One-step or Turkey Trot (T. Araullo). Victor Military Band 10
17533 All Aboard for Dixieland—One-step or Turkey Trot (Cobb). Victor Military Band 10
Ninette—One-step or Two-step (Christine). Victor Military Band 10
35364 La Brulante—One-step or Turkey Trot (Winne). Victor Military Band 12
Sari Waltzes (Kalman). Victor Military Band 12

17524 Toreador—One-step or Turkey Trot (Rafael Gascon) (Machaquito). Victor Military Band 12
Admiration—Waltz Hesitation (Carza). Cuanto te quero! Victor Military Band 10
VICTOR DOUBLE-ACED RECORDS.
35354 Faust "All Hail, Thou Dwelling Lowly" (Gounod) (Salve, dimora) (Act III). Chas. W. Harrison 12
Elixir of Love—A Furtive Tear (Donizetti) (Una furtiva lagrima). Charles W. Harrison 12
17522 Little Gray Home in the West (Eardley-Wilmoth-Hermann Lohr) (Cello Obligato by Bourdon) Charles W. Harrison 10
There are Birds in the Valley, from "Vicar of Wakefield" (Housman-Lehmann). Reed Miller 10
17523 Evening Chimes (Abendglöckchen) (Carl Heins, Op. 201) (Violin-Flute-Harp with Bells). Neapolitan Trio 10
Woodland Echoes (A. P. Wyman, Op. 34). Neapolitan Trio 10
35357 I Live and Love Thee (Campana). Elsie Baker-Frederick Wheeler 12
The Day is Done (Longfellow-Lohr). Elsie Baker-Frederick Wheeler 12
17531 Luna Waltz (Paul Lincke). Pietro Diero 10
Pietro's Return—March (Pietro). Pietro Diero 10
17476 The Wedding of the Rose—Intermezzo (Leon Jessel). Conway's Band 10
Rendez-vous—Intermezzo (The Trusting Place) (Aletter-Komzak). Victor Concert Orchestra 10
17521 Dance of the Song Birds (Benjamin Richmond) (with bird effects by Joseph Belmont). Victor Orchestra 10
The Cricket's Serenade (Theo. Bendix) (with bird effects by Joseph Belmont). Victor Orchestra 10

35351 Sea Songs. Victor Mixed Chorus 12
War Songs. Victor Male Chorus 12
17525 Song Without Words (Romance sans paroles) (D. Van Goens, Op. 12, No. 1) (Violin, Cello, Pianoforte). Tollefsen Trio 10
The Dream (Le Reve) (Thomé, Op. 55). Tollefsen Trio 10
35363 Gems from "The Girl on the Film" (Ross-Sir-may). Victor Light Opera Co. 12
Gems from "Oh, I Say" (Smith-Kern). Victor Light Opera Co. 12

FOUR NEW VESSELLA RECORDS.

35352 Hungarian Rhapsody No. 2 (Part I) (F. Liszt). Vessella's Italian Band 12
Hungarian Rhapsody, No. 2 (Part II) (F. Liszt). Vessella's Italian Band 12
35356 Lucia Sextette (Donizetti). Vessella's Italian Band 12
Jewels of the Madonna—Intermezzo (Wolf-Ferrari) (Intro. to Act. 3). Vessella's Italian Band 12
17532 1—Spring Song (Chopin); 2—Spring's Messenger (Schumann); 3—Greeting (Mendelssohn). Olive Kline 10
1—Morning Song (Grieg); 2—The Rose (Franz); 3—Brooklet (Schubert). Olive Kline 10

NEW RECORDS BY FLORENCE HINKLE, SOPRANO, Purple Label.

6011 Dreaming of You (Vocal Waltz)... Spaeth-Lehar 10
70105 Good-Bye. Tosti 12
TWO MEDLEYS FROM HERBERT SUCCESSES. BLUE LABEL RECORDS.
55039 Sweethearts—Selection (Herbert). Victor Herbert's Orchestra 12
Lady of the Slipper—Selection (Herbert). Victor Herbert's Orchestra 12

THE MARCH RED SEAL LIST.

89075 Otello-Si pel ciel (We Swear by Heaven and Earth) (Act II, Scene V.) (Verdi) In Italian. Tenor and Baritone Solo. Caruso and Ruffo 12
64393 Tosca-E lucevan le stelle (The Stars were Shining) (Act III) (Puccini) Tenor Solo in Italian. Giovanni Martinelli 10
74381 La Bohème—Racconto di Rodolfo (Rodolph's Narrative) (Act I) (Puccini) In Italian. Giovanni Martinelli 12
64392 The Swallows (Bingham-Cowen) Soprano Solo in English. Alma Gluck 10

74369 Berceuse (Lullaby from Jocelyn) (Godard) Soprano Solo in French. Alma Gluck 12
87137 Thais—Aime Fanciullo ancora ("Whilst Yet a Simple Youth") (Act I) Baritone Solo in Italian. (Massenet). Titta Ruffo 10
88366 Dinorah—Sei vendicata assai (Thou Art Avenged, Dear Love!) (Meyerbeer) Baritone Solo in Italian. Titta Ruffo 12
64345 Nearer My God to Thee (Adams-Mason) Tenor Solo in English. John McCormack 10
74379 La Paloma (The Dove) (Yradier) Baritone Solo in Spanish. Emilio de Gogorza 12
74313 Nocturne in G Major (Twelfth Nocturne, Op. 37, No. 2) (Chopin) Piano Solo. Vladimir de Pachmann 12

THOMAS A. EDISON, INC.

CONCERT LIST.

28184 Maritana—In Happy Moments (W. V. Wallace) Baritone Solo, orch. accomp. Thomas Chalmers
28189 (a) Volksliedchen (Kamzak Op. 135, No. 1); (b) Bohemian Dance (Kaessmayer Op. 14, No. 8) String Quartet. The Hofmann Quartet
28190 Dearest Name (Caro Nome) Rigoletto (Verdi) Soprano Solo, in English. Anna Case
28191 The Secret (Jno. Prindle Scott) Tenor Solo, orch. accomp. Orville Harrold

REGULAR LIST.

2179 Favorite Airs from "Mikado" (Gilbert and Sullivan) orch. accomp. Edison Light Opera Co.
2180 PUNCHINELLO (J. L. Molloy). Baritone Solo, orch. accomp. Edmund A. Jahn
2181 Love is a Story That's Old—The Madcap Duchess (Victor Herbert). Soprano and chorus, orch. accomp. Mary Carson and Chorus
2182 You've Got Your Mother's Big Blue Eyes (Irving Berlin). Tenor Solo, orch. accomp. Walter Van Brunt
2183 Stabat Mater—Inflammatu (Rossini) Cornet Solo, orch. accomp. Gustav F. Heim
2184 La Bohème—Rudolph's Narrative (Your Tiny Hand is Frozen) (Puccini) Tenor Solo, orch. accomp. Charles W. Harrison
2185 Beautiful Bird, Sing On (Bird imitation by Joe Belmont) (T. H. Howe) Soprano Solo, orch. accomp. Marie Kaiser
2186 The Old Clarinet—Oh, I Say (Jean Gilbert). Empire Vaudeville Co.
2187 Dream Days (Charles L. Johnson) Tenor Solo, orch. accomp. Manuel Romain
2188 You Need a Rag (Theodore Morse). Male voices, orch. accomp. Premier Quartet
2189 Jesus, I Come (Geo. C. Stebbins). Sacred; orch. accomp. John Young and Fred'k J. Wheeler
2190 That's How I Lost Him (Raymond A. Browne) Comic song, orch. accomp. Ada Jones
2191 Fein und chic Gavotte (Franz von Blon). United States Marine Band
2192 Aunt Mandy. Vaudeville specialty. Billy Golden and Joe Hughes
2193 The Battle Eve (Theo. Bonheur) Baritone and Tenor, orch. accomp. V. Archibald and R. Fish
2194 He'd Have to Get Under—Get Out and Get Under—The Pleasure Seekers (M. Abrahams) Billy Murray
2195 Bonnie Scotland Medley—Variations (Fred Lax) Xylophone, orch. accomp. Charles Daab
2196 There's a Girl in Arizona (Irving Berlin) Tenor Solo, orch. accomp. George Wilton Ballard.
2197 The Pussy Cat (Daly and Allen) Comic Song, orch. accomp. Peerless Quartet and Ada Jones
2198 Love Has Done Wonders for Me (Alfred Solomon) Contralto and Tenor Solo, orch. accomp. Helen Clark and Emory B. Randolph
2199 G. A. R. Patrol (Raphael Fasset). New York Military Band
2200 Who Will be with You When I Go Away (Wm. II. Farrell). Coon duet, orch. accomp. Arthur Collins and Byron G. Harlan
2201 Dixie Days (Bert Fitzgibbon) Baritone and chorus; orch. accomp. Owen J. McCormack and Chorus
2202 By the Old Wishing Well (Terry Sherman) Tenor duet, orch. accomp. A. H. Campbell and Irving Gillette
2203 Columbian Exposition March (F. W. White). New York Military Band
2204 Dreams of Galilee (C. P. Morrison) Sacred, organ accomp. Edison Mixed Quartet

VALUE OF PRICE STANDARDIZATION.

Every article that is really cheapest for man or woman to-day is really standardized. A thoughtless buyer may think she buys most carefully where she buys most cheaply. She studies the bargain columns.

In a standard article quality, cost and production go through the most minute scrutiny. It is first brought up to a standard and then sold at the very lowest price consistent with good materials, with good wages to the worker and a fair profit to the maker.

A good suit, for instance, made of honest materials that will last, made by a skilled workman who is paid decent wages so that he can do good work, can be made for just so much money, can be sold for just so much, and not a penny less.—Semi-Ready Special.

Initiative consists of doing on the spot without being told and without complaining what the other fellow never thought of doing—and didn't do when he was told.



READE your trade paper! Get The Talking Machine World regularly—It is worth many times to you its annual cost.

There is but one talking machine paper covering this entire industry, and it is admitted by all that it is of great aid to the dealers in every part of this country.

New economic conditions make certain knowledge necessary on the part of merchants, and in every issue of The World there is contained educational matter, instructive service, business news and technical articles which are worth many times the cost of the paper.

Thousands have been benefited by the business articles which appear in The World, and every talking machine dealer should receive it regularly.

The only way to do that is to pay for it, and the cost is trifling—a little over eight cents a month, and for that small sum The World, with all its mine of information, is at your service.

If you do not receive the paper regularly, just put your dollar in an envelope and address it to the office of the publication, and you will say that it is the best investment that you have ever made.

Do not delay but send on your dollar now.

Recollect that your competitor is getting The World—getting it regularly, and in it he is securing some valuable pointers—information which places you at a disadvantage if you do not read the paper.

Do not overlook such a valuable contributing factor to your business success.

EDWARD LYMAN BILL
PUBLISHER

373 Fourth Avenue,

New York City



In the Edison line there are a great many models and a great many prices, but there is just one standard of musical excellence—the standard that the master of sound reproduction has set for himself.

To the merchant that means a real musical instrument for every customer, irrespective of the price paid. And that means satisfaction.

Thomas A Edison
INCORPORATED

59 Lakeside Ave., ORANGE, N. J.

The TALKING MACHINE WORLD

AND
NOVELTY
NEWS

Published Each Month by Edward Lyman Bill at 373 Fourth Avenue, New York, March 15, 1914



Victor-Victrola XVI, \$200
Mahogany or quartered oak

The instrument by which the value of
all musical instruments is measured



Leading Jobbers of Talking Machines in America

Landay
BROS INC.

VICTOR JOBBERS Exclusively
What you want always in stock
400 Fifth Avenue
27 W. 34th Street
563 Fifth Avenue
153 W. 42d Street } **New York**

1856 **WURLITZER** 1914

VICTOR
DISTRIBUTERS
VICTORS EXCLUSIVELY

We make a specialty of getting the order out on time—every time.

The Rudolph Wurlitzer Co.
CINCINNATI and CHICAGO

Two points of supply; order from the nearer.

CHASE & WEST DES MOINES IOWA

Machines **Victor** Everything
Records in stock all
Cabinets the time.

WHOLESALE TO IOWA TRADE

Send us your name and address and we will mail you postpaid complete illustrated catalogues, giving detailed information concerning all Victor products. Showing the various styles of Victor Machines, list of all Victor Records, the entire line of Victor Cabinets, Repair Parts and all Accessories. Dealers, let us help you build a Victor business.

PERRY B. WHITSIT L. M. WELLER

PERRY B. WHITSIT CO.,

213 South High Street, Columbus, Ohio.

Edison Phonographs and Records **JOBBERS** Victor Talking Machines and Records

OLIVER DITSON COMPANY

BOSTON

Largest **VICTOR** Talking Machine Distributors East of Chicago.

Creators of "The Fastest Victor Service." Let us tell you more about our service.

W. J. DYER & BRO.
Saint Paul, Minn.

VICTOR & EDISON
Distributors

Quick Service for all points in the Northwest. Machines, Records, Supplies.

VICTOR DEALERS
TRY US FIRST

We carry the Largest Stock of VICTROLAS, RECORDS and CABINETS of any Distributor in the South.

THE CORLEY COMPANY, Richmond, Va.



Where Dealers May Secure

COLUMBIA

Product

Ready, Full Stocks, and Prompt Deliveries from Convenient Shipping Centers all over the United States.

Distributors

- Atlanta, Ga., Columbia Graphophone Co., 132 Peachtree St.
- Baltimore, Md., Columbia Graphophone Co., 306-307 North Howard St.
- Birmingham, Ala., Columbia Graphophone Co., 1818 Third Ave.
- Boston, Mass., Columbia Graphophone Co., 174 Tremont St.
- Buffalo, N. Y., Columbia Graphophone Co., 622 Main St.
- Chicago, Ill., Columbia Graphophone Co., 14 N. Michigan Ave.
- Cincinnati, O., Columbia Graphophone Co., 117-119 W. Fourth Ave.
- Cleveland, O., Columbia Graphophone Co., 913 Euclid Ave.
- Dallas, Tex., Southwestern Talking Machine Co., 1403 Main St.
- Denver, Colo., Columbia Stores Co., 505-507 Sixteenth St.
- Detroit, Mich., Columbia Graphophone Co., 114 Broadway.
- El Paso, Tex., Southwestern Talking Machine Co., Stanton and Texas Sts.
- Hartford, Conn., Columbia Graphophone Co., 719 Main St.
- Indianapolis, Ind., Columbia Graphophone Co., 27 N. Pennsylvania St.
- Kansas City, Mo., Columbia Graphophone Co., 1112 Grand Ave.
- Lincoln, Nebr., The Grafonola Company, 1036 O St.
- Livingston, Mont., Scheuber Drug Co.
- Los Angeles, Cal., Columbia Graphophone Co., 420-422 S. Broadway.
- Louisville, Ky., Columbia Graphophone Co., 425 South Fourth St.
- Milwaukee, Wis., Albert G. Kunde, 516 Grand Ave.
- Minneapolis, Minn., Columbia Graphophone Co., 424 Nicollet Ave.
- New Haven, Conn., Columbia Graphophone Co., 25 Church St.
- New Orleans, La., Columbia Graphophone Co., 333 Canal St.
- New York City, Columbia Graphophone Co., 89 Chambers St.; Columbia Graphophone Co., 35-37 W. 23d St.; Columbia Graphophone Co., 39 W. 125th St.
- Philadelphia, Pa., Pennsylvania Talking Mach. Co., 1109 Chestnut St.
- Pittsburgh, Pa., Columbia Graphophone Co., 101 Federal St.
- Portland, Me., Columbia Graphophone Co., 550 Congress St.
- Portland, Ore., Columbia Graphophone Co., 371 Washington St.; Eilers Music House.
- Providence, R. I., Columbia Graphophone Co., 119 Westminster St.
- Rochester, N. Y., The Grafonola Company, 33 South Ave.
- Sacramento, Cal., Kirk, Geary & Co.
- Salt Lake City, Utah, Daynes-Beebe Music Co., 45 Main St.
- San Francisco, Cal., Columbia Graphophone Co., 834 Sutter St.
- Seattle, Wash., Columbia Graphophone Co., 1811 First Ave.; Eilers Music House, 3d and University Sts.
- Spokane, Wash., Columbia Graphophone Co., 818 Sprague Ave.
- Springfield, Mass., Columbia Graphophone Co., 174 Worthington St.
- St. Louis, Mo., Columbia Graphophone Co., 1008 Olive St.
- St. Paul, Minn., Columbia Graphophone Co., 17 East Sixth St.
- Tampa, Fla., Tampa Hardware Co.
- Terre Haute, Ind., 640 Wabash Ave.
- Toledo, O., Columbia Graphophone Co., 229 Superior St.
- Washington, D. C., Columbia Graphophone Co., 1210 G St., N. W.

DEALERS WANTED—Exclusive selling rights given where we are not actively represented.

Write for particulars to the Columbia Graphophone Co., Wholesale Department, Woolworth Building, New York.

Headquarters for Canada:

Columbia Graphophone Co., 363-5-7 Sorauen Ave. Toronto, Ont.

SANGER BROTHERS
Dallas, Texas

VICTOR
Distributors

"We ship the same day."

Southern Victor Dealers

Largest Stock VICTROLAS and RECORDS. Prompt Shipment and Low Freight Rates.

WALTER D. MOSES & CO.
Oldest Music House in Virginia or North Carolina.
RICHMOND, VA.

Edison Phonograph Distributors
for the SOUTHWEST

All Foreign Records in Stock

Houston Phonograph Co., HOUSTON, TEXAS

NEW ENGLAND
JOBBER HEADQUARTERS
EDISON AND VICTOR

Machines, Records and Supplies.

THE EASTERN TALKING MACHINE CO.
177 Tremont Street BOSTON, MASS.

PACIFIC COAST DISTRIBUTORS OF

Victor Talking Machines and RECORDS

STEINWAY PIANOS—LYON & HEALY
"OWN MAKE" BAND INSTRUMENTS

Sherman, Clay & Co. San Francisco Portland
Oakland Los Angeles

Talking Machine Dealers

Who are desirous of adding new features to their line should consult

The Music Trade Review

This is the oldest music trade publication in this country, having appeared without interruption since July, 1879.

It is published every Saturday, and contains a thorough and exhaustive resume of all departments of the music trade industry.

Its editions vary from 60 to 150 pages.

It is conceded to be the most influential paper representing the music trade, and if you are interested in the topics with which it deals, do not fail to receive this paper regularly.

Ask for a sample copy.

Regular subscription price is \$2 per year.

EDWARD LYMAN BILL
EDITOR AND PROPRIETOR

373 Fourth Ave., New York

Every Jobber in this country should be represented in this department. The cost is slight and the advantage is great. Be sure and have your card in the April List.

The Talking Machine World

Vol. 10. No. 3.

New York, March 15, 1914.

Price Ten Cents

TO OPEN NEW RETAIL STORE SOON.

Milwaukee Phonograph Co. Expects to Get Into New Quarters Late This Month—Manager for Retail Department Not Yet Selected.

(Special to The Talking Machine World.)

MILWAUKEE, Wis., March 9.—The Milwaukee Phonograph Co., jobber in Wisconsin for the Edison line, has met with some little delay in opening its big new retail Edison store, but Manager William A. Schmidt expects that the new establishment will be formally opened before the latter part of March. Workmen are now busy remodeling the quarters at 213-215 Second street, where two floors will be occupied by the new retail store and by the wholesale department, which will be removed from its present location at 347-349 Broadway. No money will be spared in making the store one of the finest retail talking machine establishments in Milwaukee, and the local trade will await with interest the opening of the new place. Mr. Schmidt says that he has not fully decided as yet upon a manager for the new retail department. The Milwaukee Phonograph Co. has started several new Edison dealers about Wisconsin, and business at the present time is three times what it was a few months ago.

BIG FIRE IN PITTSBURGH.

Store and Stock of Columbia Graphophone Co. Completely Destroyed—Loss Estimated at \$90,000—Temporary Quarters Secured.

(Special to The Talking Machine World.)

PITTSBURGH, Pa., March 5.—The store and stock of the Columbia Graphophone Co., located in the Fulton building, 101 Sixth street, was totally destroyed by fire which broke out Sunday and got beyond the control of the firemen, owing to the high wind and zero weather. The firemen estimated the loss at \$90,000 but the company officials, who are at present taking an inventory, believe that the estimate is rather high, despite the fact that the local branch was an active distributing center and a large stock was carried. The loss is fully covered by insurance.

On Monday morning Manager S. H. Nichols secured temporary quarters in the Bessmer building, directly opposite the burned building. All the important papers connected with the business were locked in the safe and were saved from destruction.

THE GRAFONOLA ON THE STAGE.

Plays Important Part in First Two Acts of "The Spendthrift" and Pleases Audience.

(Special to The Talking Machine World.)

ATLANTA, Ga., March 5.—The Columbia Grafonola was used to excellent advantage in performances of "The Spendthrift" which were recently given at the Princess Theater in this city. The appearance of the machine attracted general interest and its musical qualities were commended by many of the newspaper critics.

The play called for the use of the Grafonola in the first two acts, and in the second act the curtain rises while the machine is playing "Idilio." The machine plays for nearly five minutes, and the success of this demonstration was well evidenced by the fact that the machine held the attention of every person in the audience and was even encored.

McGREAL TO RUN FOR CONGRESS.

(Special to The Talking Machine World.)

MILWAUKEE, Wis., March 5.—Lawrence McGreal, formerly Edison jobber in Milwaukee, and a former president of the National Association of Talking Machine Jobbers, is being urged by his friends to make the formal announcement of his candidacy for Congress from the Fifth Congressional District on the Democratic ticket. Mr. McGreal, who is now sheriff of Milwaukee County, has just returned from California.

KILL PROPOSED INSTALMENT BILL.

Delegation of Talking Machine, Piano and Furniture Men Visit Albany to Outline Danger of Proposed 80 Per Cent. Clause—Maker of Bill Only One to Appear in Its Favor—E. K. Camp Appears in Opposition.

Talking machine dealers throughout New York State were greatly interested in a hearing which was held February 25 before the Committee of General Laws of the Assembly, at Albany, N. Y., relative to a proposed amendment to the Personal Property Law. This bill, which was known as Assembly Bill 287, and introduced by Assemblyman Sufirin, had for its purpose the adding of another section to the Personal Property Law which would force the vendor in a conditional sale to pay back to the vendee 80 per cent. of the money paid on the contract before starting to recover the goods in case of default of payment. This is the same bill that was introduced last year, and which made no progress before the Assembly session came to a close.

In view of the rapid growth of instalment sales in the talking machine business, the proposed bill loomed up as a most important matter, as it practically made the sale of talking machines on an instalment basis an impossibility. E. K. Camp, the able counsel for the Columbia Graphophone Co., attended the hearing before the committee, as did representatives of the piano and other interested trades.

The hearing as a whole was decidedly one-sided, no one appearing in favor of the bill except Assemblyman Sufirin, who drafted it. The utter absurdity of the 80 per cent. clause was brought out early in the hearing, and after listening to several of the spokesmen for the furniture industry and Mr. Sufirin's plea for the bill, Chairman Smith, of the General Laws Committee, publicly asked the members of the committee if any one of them was in favor of the bill, and receiving no response in the affirmative indicated that he thoroughly understood the details of the situation, and required no further arguments in opposition to the bill.

Assemblyman Sufirin, at the start of his argument, stated his desire to offer several compromises, including the elimination of musical instruments from the provision of the bill, limiting the bill to necessities only, but was not quite certain as to what came under the head of "necessities." The apparent unanimous opposition of the General Laws Committee to the bill practically eliminates any chance of its becoming a law, and there is every indication that the present provisions of the Personal Property Law will not be changed during the session.

VICTROLA MAKING YOUNG MOZARTS.

Crandall Hendershot Becomes a Vocalist at the Age of Three, Thanks to the Victrola.

(Special to The Talking Machine World.)

CLEVELAND, O., March 7.—It is history that Mozart at the age of three played well on the clavichord. If this can be taken as a criterion of youthful precociousness in the musical realm, then a brilliant future awaits Crandall, the son of Fred K. Hendershot, of the suburban town of Chardon, who is an enthusiastic admirer of the Victrola and can sing a repertoire of popular songs, though he has not yet reached the age of three. Musicians, who have heard the boy sing, are astounded at the correctness of key, the perfect time he maintains, and his clear enunciation. Among the songs the boy sings perfectly are "On Moonlight Bay," "Jungle Moon," "Marching Through Georgia."

When the Victrola plays he isn't satisfied until his parents let him stand in front of the talking machine, where with improvised baton, he beats time with absolute precision.

THE GOSPEL OF COMMERCE.

This Is How Modern Advertising Is Considered by Thinking Business Men—Honesty and Honor Keynotes of Success in Commercial Sphere Today—Past and Present Compared.

Advertising has undergone a great change in the past twenty-five years. To-day it is the good word—the gospel of commerce.

In an elder day, it was a cunning device by which the commercial cut-purse seduced the unwary into trading with him. The advertising man then became a hired liar, paid to do that which the proprietor has neither the moral backbone nor the power to do himself.

Times have changed, because men have changed and business with them.

There never was a time when honesty was more honored—when service brought greater rewards than to-day.

The world is changing its faith. This is the greatest spiritual era the world has had for one hundred years. As E. St. Elmo Lewis says, it is not sufficient any more for a man to be a success to be accepted in the market place—he must have more than money—he must have a soul.

If he misdescribes an article in his advertisement, shall he be accounted an honest man?

Shall he be accepted as an honorable man if he makes selfish and subtle distinctions between what he would tell the stranger across his counter and what he would describe to one of his own family?

COLLECTS INDIAN TRIBAL SONGS.

Miss Frances Densmore Makes Records of Indian Tribal Songs and Greatly Interests Members of the Anthropological Society at a Recent Session—Some Remarkable Results.

Sioux war songs were sung and war stories were recently shown before the members of the Anthropological Society by Miss Frances Densmore at the National Museum in Washington. Miss Densmore has been making a special study of Indian music for the Bureau of Ethnology for some years.

She goes into the field with a Columbia cylinder graphophone and a musical note book, and collects the tribal songs and their accompanying legends almost as a botanist would collect flowers. The series presented to the Anthropological Society was the result of a season's work among the Sioux. There was a phonograph record of an Indian woman singing a death song for her husband, who had been killed in battle. Most of the songs were wild, quavering minors, and some had strange changes of time and curious "accidentals" in the score.

PHONOGRAPH FOR HIGH SCHOOL.

North Des Moines High School Selects a \$250 Fumed Oak Edison Disc Phonograph.

(Special to The Talking Machine World.)

DES MOINES, IA., March 7.—About a year ago the people interested in the welfare of the North Des Moines High School (which is one of three of our big high schools) decided to raise a fund for the purchase of a talking machine. When their fund had been brought up to the required amount they looked around to make their choice. After having had submitted to them in a competitive test the various makes of phonographs, the Edison salesman "came home with the bacon," having sold them not a \$200 instrument, which they had decided to spend, but a \$250 fumed oak Edison disc phonograph. Every member of the committee and of the school, and everyone around the school interested in this matter is highly delighted.

SOMETHING WORTH EMPHASIZING.

A man may have a lot of sand without ever letting you suspect it, but the fellow with nerve always lets you know he has it.

QUESTIONS OF VITAL INTEREST WERE DISCUSSED

At the Recent Annual Meeting of the Chamber of Commerce of the United States Held in Washington Bearing on the Talking Machine Trade—Oldfield Bill Denounced and the Maintenance of Retail or Resale Prices to Be Investigated Officially.

(Special to The Talking Machine World.)

WASHINGTON, D. C., March 6.—At the second annual meeting of the Chamber of Commerce of the United States which was held in this city late last month, not only were many topics of national interest affecting every phase of business discussed, but questions of immediate moment to talking machine men, such as the Oldfield bill and the matter of resale of prices were up for consideration.

It was perhaps the most representative gathering of the leading business men of the country ever assembled, and the discussions and reports were carried on on a broad plane with a splendid spirit of good will on all sides, the aim being to arrive at conclusions that would tend to uplift the commercial affairs of the United States and elucidate many of the perplexing questions that are now up for consideration.

The Oldfield Bill Denounced.

The talking machine trade interests were concerned when on the very first day of the Chamber meeting the committee on patents, trade-marks and copyrights brought in a report vigorously denouncing the Oldfield bill, which strikes at price maintenance and recommending the amendment of the Kahn act, which is a measure looked upon with suspicion by many manufacturers of musical instruments of a class that are liable to involve a conflict of foreign and American patents. Recommendations were made for the creation of an expert commission empowered to investigate the patent laws and for the establishment of a court of patent appeals, to which cases may be taken by either party to a patent suit. This court of patent appeals would do away with confusion such as has, on certain occasions, being precipitated in the music trade when a patent has been declared by the Circuit Court of Appeals in one district to be valid and to have been infringed, whereas the Circuit Court of Appeals in another district had held this self-same patent to be invalid.

In criticising the compulsory license provisions of the Oldfield bill, the Chamber of Commerce committee said: "The enactment into law of this provision would surely tend to induce everyone to keep his inventions secret and never place them upon the public patent record." In condemning the Oldfield bill for the limitations it places upon the right to enforce restrictions on the sale or use of patented articles, the report submitted to the national Chamber of Commerce says: "The restriction of conditions of use and sale is a ques-

tion of the 'distribution' of the particular manufacturers' goods and is not one in which the public is interested. The retail dealers are heartily in favor of having the manufacturer maintain a fixed retail price."

Maintenance of Retail or Resale Prices.

One entire session of the Chamber meeting was given over to a discussion of the subject of the maintenance of retail or resale prices, and in the end it was decided to appoint a special committee to investigate this subject also. An interesting feature of the presentation of this subject was an announcement by the United States Commissioner of Corporations, Joseph E. Davies, who has been charged by the Secretary of Commerce with the making of an official investigation of this subject.

Commissioner Davies let out the secret that an effort is now being made in certain quarters to have price maintenance sanctioned by law; that is, to have an express statute enacted that will give manufacturers under certain conditions the right to fix the prices at which the articles of their manufacture, respectively, shall be sold to the ultimate consumers. Then, telling of his own plans, he said: "The Bureau of Corporations is now engaged in an exhaustive study of the question from an economic point of view. It is our purpose to make that investigation fair and impartial, without preconceived bias, prejudice or judgment. We are collecting our information from both sides and with equal fairness. We are meeting with cooperation in this investigation and we ask your continued aid as business men in our work."

Protection from Price Juggling.

"Protection from Price Juggling" was discussed by William H. Ingersoll, of New York, a member of the American Fair Trade League, which has enrolled members from the talking machine and music trade. Mr. Ingersoll was particularly severe in his denunciation of price cutting and "bargain offers," saying that this form of advertising tended to undermine public confidence in advertising statements of all kinds. Said he: "In all of this advertising goods are offered at approximately one-third less than they are said to be worth, and such a perpetual avalanche of bargains would tax our credulity unless substantiated by very tangible evidence that real bargains of such proportion are possible.

"When a well-known article is sold at a cut price, the first effect is a stimulated demand, if the offer is bona fide. Oftentimes such offers are made with a very limited stock on hand, however,

and 'something else' is offered to those who arrive after 10 o'clock. The secondary effect is that people are led to believe that they ought to get the goods regularly at the reduced price and that those who charge more are exacting extortionate profits; the goods are cheapened in their estimation; they are no longer satisfied to pay former prices, so that the good will of the maker is seriously impaired."

Attack Quantity Discounts.

Men engaged in the various branches of the trade may find food for reflection in an attack which this speaker at the Chamber made upon the present system of quantity discounts. His statement on this score was: "It is worthy of note that the present unscientific, unfair scale of quantity discounts allowed generally to large buyers is turning the retail business into one, not of merchandising, but of financial manipulation to combine outlets so as to gain buying power and be able to underbuy the general run of merchants. A premium is put upon mere size, permitting wastefulness of management through unearned buying advantage, penalizing the small independent dealer, closing the way to the newcomer and making it impossible for the individual retailer to compete regardless of how capable he may be. Quantity discounts should be reduced to a scientific scale or abolished, as rebates for quantity freight shipments have been abolished under the law."

The so-called anti-trust bills which are now before Congress were strongly opposed, and it was the general belief of those present that in their present form they would work a distinct hardship to and harass the business of the country.

There was also an interesting discussion upon the effect of the "chain store" upon modern business conditions, and in order to indicate the spread of the chain store idea it was stated at the meeting that Boyd's Dispatch now lists more than 10,000 separate chain store systems in this country, and the fear was expressed by some speakers that the power which resides in the great chain store systems is a decided menace if there is any possibility that it will be used for price dictation or for the elimination of the individual retailer.

JULIAN ELTINGE FALLS IN LINE.

C. S. Calveard, manager of the Victrola department of the Montenegro-Riehm Music Co., Louisville, Ky., recently closed a sale of unusual importance in the nature of a Victrola and a large supply of records to Julian Eltinge, the well-known actor and female impersonator. Mr. Eltinge was delighted with the musical qualities of the Victrola and contemplates placing it in his private car to accompany him on all his travels.

Some people go to a moving picture show because it doesn't make them think. Others go because it does. And there you are.

It Requires No Great Stretch of the Imagination to Realize That Eastern Service Must Be Good

CONSIDER: The fact that we have been handling talking machines, records and supplies *exclusively* for nineteen years.

- : That our entire time, energy and attention is devoted to one line.
- : That constant application is given to the betterment of our service.
- : That our stock is large, complete and up-to-date, and our shipping facilities unusual.

THEN YOU HAVE some of the reasons why EASTERN SERVICE is different from the ordinary.

The absolute proof is in the trying. Try it.

EASTERN TALKING MACHINE COMPANY

177 TREMONT STREET, BOSTON, MASS.

EDISON

FOR NINETEEN YEARS TALKING MACHINES EXCLUSIVELY

VICTOR



Victor-Victrola VI, \$25
Oak



Victor-Victrola IX, \$50
Mahogany or oak

Victor-Victrola

The Victor-Victrola combines all the best qualities of all musical instruments. It is a leader of music and of all things musical—the vital force of the musical world. Its unequaled tone and its artistic appearance have put the Victor-Victrola into homes of culture and refinement everywhere.

The commercial triumphs of the Victor-Victrola have been in keeping with its musical successes. It has turned the stores of Victor dealers into the modern and impressive places of business they are to-day, and raised the entire musical industry to a higher and more substantial basis.

And the unprecedented opportunities for prestige and profits keep on growing larger and larger with every new development of this wonderful instrument.

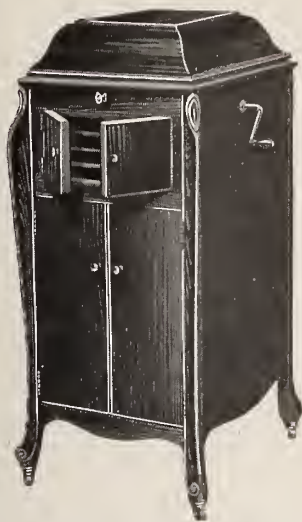

Victor-Victrola XI, \$100.
Mahogany or oak

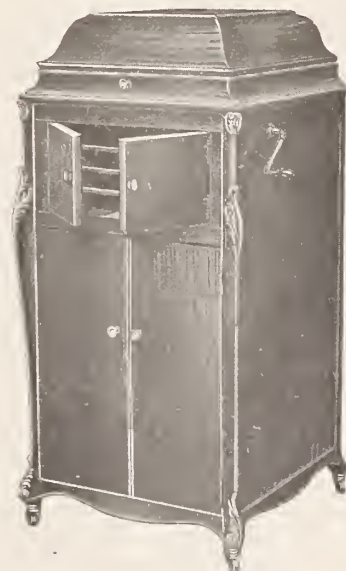

Victor-Victrola XVI, \$200
Mahogany or oak

Victor Talking Machine Co.,
Camden, N. J., U. S. A.

Berliner Gramophone Co., Montreal, Canadian Distributors

Always use Victor Machines with Victor Records and Victor Needles—the combination. There is no other way to get the unequalled Victor tone.

Victor Distributors

Albany, N. Y. Finch & Hahn.
 Altoona, Pa. W. F. Frederick Piano Co.
 Atlanta, Ga. Elyea-Austell Co.
 Phillips & Crew Co.
 Austin, Tex. The Talking Machine Co. of
 Texas.
 Baltimore, Md. Cohen & Hughes, Inc.
 E. F. Droop & Sons Co.
 H. K. Eisenbrandt Sons.
 Bangor, Me. Andrews Music House Co.
 Birmingham, Ala. Talking Machine Co.
 Boston, Mass. Oliver Ditson Co.
 The Eastern Talking Machine
 Co.
 M. Steinert & Sons Co.
 Brooklyn, N. Y. American Talking Machine Co.
 Buffalo, N. Y. W. D. Andrews.
 Neal, Clark & Neal Co.
 Burlington, Vt. American Phonograph Co.
 Butte, Mont. Orton Brothers.
 Chicago, Ill. Lyon & Healy.
 The Talking Machine Co.
 The Rudolph Wurlitzer Co.
 Cincinnati, O. The Rudolph Wurlitzer Co.
 Cleveland, O. The W. H. Buescher & Sons Co.
 The Collister & Sayle Co.
 The Eclipse Musical Co.
 Columbus, O. Perry B. Whitsit Co.
 Dallas, Tex. Sanger Bros.
 Denver, Colo. The Hext Music Co.
 The Knight-Campbell Music Co.
 Des Moines, Ia. Chase & West Talking Mach. Co.
 Mickel Bros. Co.
 Detroit, Mich. Grinnell Bros.

Elmira, N. Y. Elmira Arms Co.
 El Paso, Tex. W. G. Walz Co.
 Galveston, Tex. Thos. Goggan & Bros.
 Honolulu, T. H. Bergstrom Music Co., Ltd.
 Indianapolis, Ind. Stewart Talking Machine Co.
 Jacksonville, Fla. Florida Talking Machine Co.
 Kansas City, Mo. J. W. Jenkins Sons Music Co.
 Schmelzer Arms Co.
 Lincoln, Neb. Ross P. Curtice Co.
 Little Rock, Ark. O. K. Houck Piano Co.
 Los Angeles, Cal. Sherman, Clay & Co.
 Louisville, Ky. Montenegro-Riehm Music Co.
 Memphis, Tenn. O. K. Houck Piano Co.
 Milwaukee, Wis. Wisconsin Talking Machine Co.
 Mobile, Ala. Wm. H. Reynolds.
 Montreal, Can. Berliner Gramophone Co., Ltd.
 Nashville, Tenn. O. K. Houck Piano Co.
 Newark, N. J. Price Talking Machine Co.
 New Haven, Conn. Henry Horton.
 New Orleans, La. Philip Werlein, Ltd.
 New York, N. Y. Blackman Talking Machine Co.
 Sol. Bloom, Inc.
 Emanuel Blout.
 C. Bruno & Son, Inc.
 I. Davega, Jr., Inc.
 S. B. Davega Co.
 Chas. H. Ditson & Co.
 Landay Brothers, Inc.
 New York Talking Machine Co.
 Sllas E. Pearsall Co.
 Benj. Switky.

Omaha, Neb. A. Hospe Co.
 Nebraska Cycle Co.
 Peoria, Ill. Putnam-Page Co., Inc.
 Philadelphia, Pa. Louis Buehn.
 C. J. Hepp & Son.
 Penn Phonograph Co., Inc.
 The Talking Machine Co.
 H. A. Weymann & Son, Inc.
 Pittsburgh, Pa. C. C. Mellor Co., Ltd.
 Standard Talking Machine Co.
 Portland, Me. Cressey & Allen, Inc.
 Portland, Ore. Sherman, Clay & Co.
 Richmond, Va. The Corley Co., Inc.
 W. D. Moses & Co.
 Rochester, N. Y. E. J. Chapman.
 The Talking Machine Co.
 Salt Lake City, Utah Consolidated Music Co.
 San Antonio, Tex. Thos. Goggan & Bros.
 San Francisco, Cal. Sherman, Clay & Co.
 Savannah, Ga. Phillips & Crew Co.
 Seattle, Wash. Sherman, Clay & Co.
 Sioux Falls, S. D. Talking Machine Exchange.
 Spokane, Wash. Sherman, Clay & Co.
 St. Louis, Mo. The Aeolian Company of Mo.
 Koehler-Brenner Music Co.
 St. Paul, Minn. W. J. Dyer & Bro.
 Koehler & Hinrichs.
 Syracuse, N. Y. W. D. Andrews Co.
 Toledo, O. The Whitney & Currier Co.
 Washington, D. C. Robert C. Rogers Co.
 E. F. Droop & Sons.

UNIQUE RECORD ALBUMS

CONTAINING SIX PAGES OF INDEX

For Durability, Artistic Design and Finish, our Albums have no equal. They are made in the most substantial manner by skilled workman, and are first-class in every particular. We sell them at very low prices to meet competition.

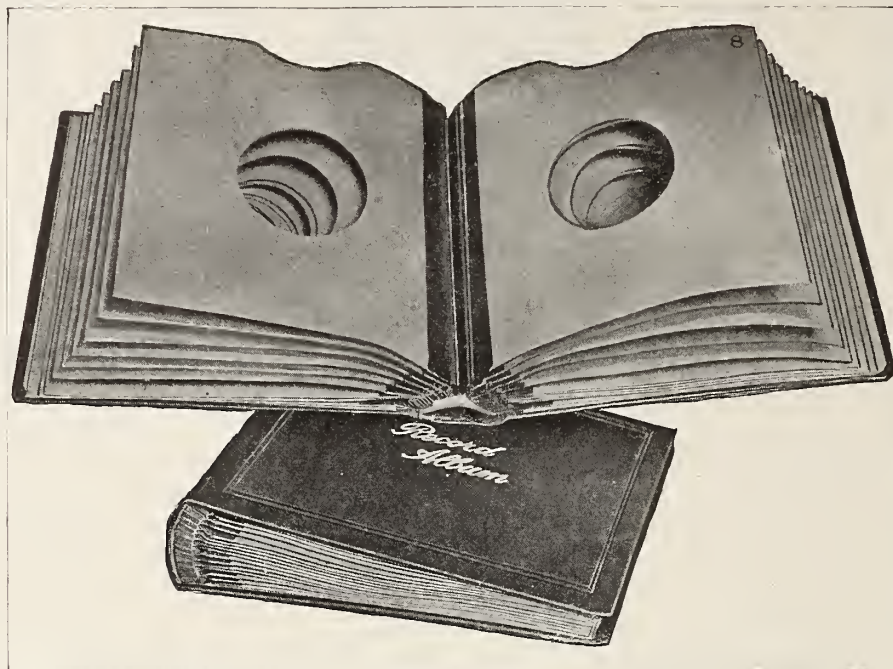

DISC RECORD ALBUMS
ARE WHAT EVERY
Talking Machine Owner
MUST NOW HAVE

With the index they make a complete system for filing away all disc Records, and can be added to, Album by Album, as Records accumulate, like books in a library.

OUR SUPERB ALBUMS ARE BEST FOR VICTOR, COLUMBIA AND ALL OTHER TALKING MACHINES

MADE IN TWO SIZES TO FIT ALL 10 AND 12-INCH DISC RECORDS

These Albums contain 17 pockets made of strong fibre paper, each pocket having a hole in the center, as shown in the picture. These pockets are so made that they show very plainly both the single and double face titles on the Records. The Albums are bound in the finest quality of Brown Silk Finish Cloth, with gilt title on front cover. They are also bound in imitation leather. Write for sample and prices of our Albums, which are superior to all others.

Address NATIONAL PUBLISHING CO., 235 South American St., Philadelphia, Pa

TRADE ACTIVITY IN CLEVELAND CONTINUES.

Despite Dulness in Many Lines Talking Machine Business Made Splendid Showing for January—Outlook for March Better Still—The Phonograph Co. Carrying on Active Campaign—Monthly Concerts of Eclipse Musical Co. a Feature—News of Month.

(Special to The Talking Machine World.)

CLEVELAND, O., March 9.—March, ushering in spring, though it came in like a lion, finds the various talking machine jobbers and retailers in the very best of spirits. All through the winter months trade continued good, and generally satisfactory, but with the coming of mild weather, good walking and sunshine, trade has taken on new life, and there is great expectancy of a brisk, profitable spring business.

At the Ashtabula County teachers' annual meeting, Dr. W. H. Squires, of the department of philosophy in Hamilton College, Clinton, N. Y., predicted that "teachers will soon be displaced by 'canned education,'" inferring that the talking machine will be adopted in educational work.

A private musical recital was given by the Phonograph Co., in the recital hall, March 2. The program included the latest Edison operatic selections and a number of the March records. The audience signified their appreciation of the entertainment by frequent applause.

Mr. Cadell, expert in the manufacturing department of the Victor Co., paid the Eclipse Musical Co. a visit recently, and demonstrated the new motor just put out. The officers of the Eclipse were greatly pleased with his visit.

W. A. Condon, of the Masterphone Corporation, New York, spent several days visiting dealers the first of the month, exhibiting the attachment, using the fibre needle. He secured a large number of orders in the city.

Oliver Jones, of the Victor Talking Machine Co., was a visitor here on the first of the month. He was on his way West and stopped over for a few days.

The retiring from business of the Marks Co., eliminates the talking machine department, which seemed to be in a prosperous condition. Other departments of the store failed to respond profitably, and a receivership resulted.

The monthly concerts given by the Eclipse Musical Co., under the direction of Fred E. Lane, are decidedly interesting. The store is filled to capacity each month.

R. A. Alpers, manager of the Taylor Arcade branch of the Phonograph Co., is handling a large amount of business. He is an ardent Edison adherent.

The expanding business of the Eclipse Musical Co., is an indication of the prosperity of the Victor dealers. P. J. Towell says business in the wholesale department would be limitless if he could only get all the goods he wanted when he wanted them. The shortage is more especially in the line of records, the demand for which is growing beyond the resources of the manufacturers.

T. H. Towell, who has just returned from a visit at the Victor factory, where he spent several days, expressed himself astonished at the magnitude of the diversified business the Victor Company is handling. He says that if the company had the facilities to turn out ten times its present output, the goods could be sold, as it already has orders for that amount ahead.

The business of the Phonograph Co. has demonstrated that the Edison disc phonographs are formidable competitors. The business of the company has steadily increased since the opening of the distributing store, and for the month of February exceeded that of December last. The manager says the retail business has exceeded all ex-

pectations. A number of new dealers have been signed up. Among the more prominent are: L. Weir, Clark avenue, city; the Hunter Jewelry Co., St. Clair avenue, city; Homer S. Williams Co., Youngstown; the Wickins Co., Lorain and Yingling Bros., Newcomerstown. The above named joined the "Edison Disc Association" as charter members.

L. N. Bloom and B. W. Smith, of the company, recently spent a few days at the Edison factory, and Mr. Bloom says the visit was a most interesting and profitable one.

Notwithstanding that Wm. Taylor, Son & Co. are adding several stories to the building, business is going on as usual. Mr. Davis, manager, says trade is better than ever, and that sales of both Victor and Columbia goods are fine.

The Victrola display of the Caldwell Piano Co. is attractive, and the business of the department is continually increasing. The fine demonstration rooms are usually crowded.

Everything musical is being called for at McMillian's, and the Victrolas and Edison phonographs are leading the procession. Mr. Kellogg said business was very much better than had been anticipated, and that the prospects looked good.

That business is pre-eminently good in the talking machine department of the W. F. Frederick Piano Co., is self-evident. The store is usually crowded with customers, and Manager N. H. Cook is pleased with the outlook.

The most satisfactory conditions exist at the store of the W. H. Buescher & Sons Co. Sales cover the entire line of Victor machines and records, and business is astonishingly good.

The department stores report very satisfactory business in the talking machine departments. Mr. Friedlander, of the Baily Co., says the company closed the largest February sales of Victors and Edisons it ever had. Miss Ethel M. Voke, of the May Co., reports machine and record sales away ahead of last year.

GENERAL CONDITIONS FAVORABLE ON PACIFIC COAST.

Crop Prospects Excellent Owing to Plenty of Rain—Distributors of Victor, Columbia and Edison Products Report Increasing Demand—Opening of Opera Will Help High-Class Trade—Appointment of New Edison Dealers—News of Month Worth Recording.

(Special to The Talking Machine World.)

SAN FRANCISCO, March 5.—The talking machine trade here, as well as business men generally, are very well pleased with the situation in California at present. The State has been thoroughly soaked with rain for the first time in three years at least, and consequently the crop outlook is better than for some time past. With general conditions favorable, talking machine dealers anticipate a banner year. The general tendency on their part is to get their stocks in very good shape, both in respect to records and machines, and there is every indication of increasing popularity for the talking machine in this section, rather than a falling off in demand or even a standstill. Distributors of Victor, Columbia and Edison products, all three, report a steadily increasing demand. As to dance records, they are still demanding a great deal of attention, and are undoubtedly the principal feature of the business at the present time, although the appearance of several artists in this vicinity the past month, and others due in the next two weeks, has as usual stimulated the demand for their particular records to a very noticeable extent. Dealers have taken full advantage of their engagements, by arranging special window displays featuring their records. With the grand opera season opening in San Francisco the middle of March, an increased demand for operatic selections is anticipated in the next few weeks. On the whole the outlook for record business for the coming month is particularly good.

February Business Proves Excellent.

W. S. Gray, district manager for the Columbia Graphophone Co., and F. Anglemier, manager of the local wholesale department, reports a very good month's business in February, in spite of the interference to traffic in certain parts of the State on account of washouts. Locally, the demand for both records and machines has been gratifying to them. Realizing the important position of the popular dance records and also the advantages of co-operation, Mr. Gray has inaugurated a plan for monthly meetings of the force connected with this office, at which attention is divided between business and pleasure. They are held as soon as possible upon the receipt of the month's new records, and these are all tried out for the benefit of those connected with the establishment, so when a record is mentioned everybody will know exactly what is being talked about. These meetings are of an informal nature, and open for free discussions, such as to stimulate enthusiasm all around.

A. Glenn to Return to Business.

Word has been received here that A. Glenn, manager of the Columbia Graphophone Co.'s headquarters in Portland, Ore., who has been out on leave of absence for some little time for the benefit of his health, will visit in San Francisco before resuming his duties in the North, which, during his absence, are being looked after by L. D. Haeger, traveler for the company in the Northwest.

Increasing Demand for Victor Goods.

Andrew G. McCarthy, treasurer of Sherman, Clay & Co., who devotes particular attention to the talking machine department, says the demand for Victor goods continues to increase steadily. This week the company received a request from the Los

Angeles distributing station for more space, in order to provide better facilities for supplying an increasing demand for Victor products in the southern part of the State. Here the appearance of Kreisler, John McCormack, Harry Lauder, Tetrassini and other Victor artists during February and March, has been observed by Sherman, Clay & Co., by making special features of their records, and with very good returns, according to Mr. McCarthy. He says the craze for dance music continues unabated, and that Victor dealers are having difficulty in keeping their stocks complete.

Growing Popularity of Edison Line.

J. S. Baley, manager of the local branch of Babson Bros., reports business keeping up in fine shape since the first of the year. He says his greatest difficulty at present is to get enough disc records. He finds interest increasing rapidly in the Edison disc products, and at the same time has no complaints to make about cylinder business.

Returns from Honolulu.

L. V. Ridgeway, the well-known representative of Lyon & Healy, stopped over in San Francisco for a few days recently upon his return from Honolulu.

Many New Edison Disc Dealers.

A. R. Pommer, of the Pacific Phonograph Co., reports a very good month's business in Edison products for February. A number of new dealers have taken on the disc line, including J. T. Bowers & Son, here; the Hale Piano Co., in Medford,

Ore.; the Silvers Piano Co., in Tacoma, Wash., and Ramaker Bros. in Seattle, Wash. J. E. McCracken, traveler for the San Francisco house, is still in the Northwest, assisting in getting things started at Seattle. He is now making a trip over Oregon in company with Mr. Schwab, traveler for the new Seattle firm, which will look after that territory in the future. Another traveler has been engaged by the Pacific Phonograph Co., N. W., in the person of C. E. Lyons, formerly special representative of the phonograph department of Thomas A. Edison, Inc. He is making his initial trip around Seattle.

Interesting Personal Items.

Special representative, E. V. Chandler, of Thomas A. Edison, Inc., has been calling on the trade in southern California for the last two weeks, and upon leaving here expected to cover Arizona before returning.

A. McDowell, dealer of Petaluma, Cal., was a recent visitor at local talking machine warerooms, placing orders for stock, also Mr. Logan, of the Logan Music Co., Salinas, Cal.

Peter Bacigalupi, Jr., started in several months ago to do a cash business in talking machines, and he claims his plan is working out very well, that there are plenty of people in position and willing to pay cash for machines, in spite of the liberal terms usually offered by dealers.

L. E. Cooley, superintendent of schools in Imperial County, recently endorsed a plan for providing talking machines at all the schools in that county, in the near future.

Byron Mauzy was the only representative of the music trade going to Los Angeles recently on the Exposition Flying Legion. He took along a player-piano and a Victor Victrola for the entertainment of the "boosters."

AN ORIGINAL SERIES OF RECITALS

Held in Wanamaker Concert Hall, New York, Feature the Victrola in a Prominent Way—“The Study of Music” Well Presented.

The Victrola played a prominent part last month in a "Study of Music," which was featured in the auditorium of the New York store of John Wanamaker. This interesting and original series of recitals purposed to present a chronological study of music, accompanied by interpretations of the dance in various forms. The Angelus player-piano was also presented as an important incentive to the present revival of dancing.

Elaborate programs for these interesting recitals had been prepared, and the Victrola appeared to excellent advantage as a medium for furnishing the correct music to illustrate the dances of various periods. In certain selections the Victrola and Angelus were played in conjunction, the effect being most delightful.

The "Study of Music" had been advertised extensively in the daily newspapers, and as a result, it was necessary to turn away many music-lovers who had been attracted by the originality of the concerts and appreciated the value of hearing the Victrola in such appropriate surroundings. Soprano solos, violin solos and duets were also included in the daily performances, which were given the last two weeks of February.

In addition to the unique presentation of this "Study of Music," these concerts served to impress on the minds of the music-lovers, the true value of the Victrola as an important factor in the cultivation of musical tastes. The musical prestige of the Victrola was never more emphatically pre-

sented than at this series of Wanamaker recitals, and it is interesting to note that the store's Victrola section closed a number of sales of expensive machines to visitors to the concerts who had been impressed with the character of the Victrola's performance.

The New York store of John Wanamaker has now in preparation several other original plans which will serve to still further illustrate the musical standing of the Victrola.

PHONOGRAPH HIS GREAT SOLACE.

An Affecting Story of the Late Col. Ralph B. Eads and His Admiration for the Phonograph.

Instead of the reveille to which he had long been accustomed in the army, Col. Ralph B. Eads (retired), of Newton, Mass., each morning had his Edison phonograph play his favorite hymn, "Abide with Me." True, the second stanza, "Fast Falls the Evening," seemed to make it more of a sunset than a sunrise hymn; nevertheless, the Colonel wanted to hear each morning his favorite hymn on rising and was particularly fond of the last stanza, "Heaven's Morning Breaks at Last." At last it did break; the Colonel was dead, and among his effects was found a request that this favorite hymn of his should be played once more on an Edison at his funeral. His wish was complied with, and among the mourners present were several army officers and veterans, whose eyes were moist as they listened. To an observer the scene suggested that wonderful painting entitled "The Last Muster."

No honest purpose is ever wasted and no honest desire ever remains unanswered.

The Columbia automatic stop. The most accurate automatic stop made and the easiest to operate.

Gun Metal, \$2.00 list. Nickel Plated, \$2.50 list. Gold Plated, \$3.00 list.

May be adjusted to both Columbia and Victor disc machines. Order from any Columbia Distributor.



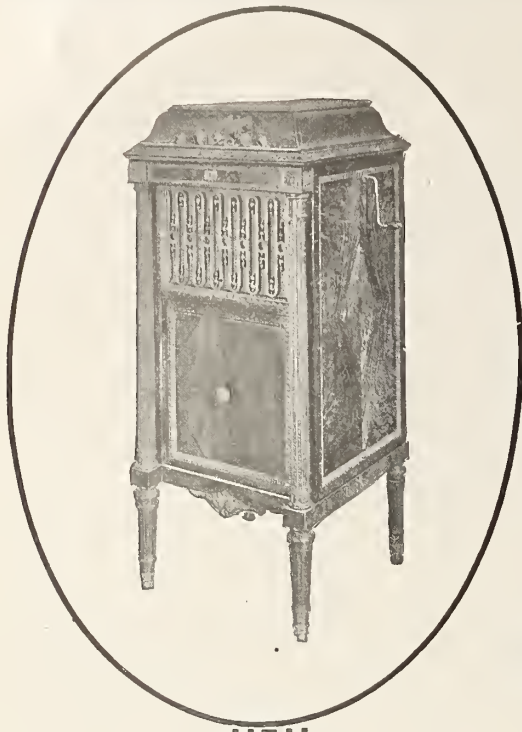

LOUIS XVI
Model A450, Circassian Walnut, \$450.00
Model A400, Mahogany, \$400.00



SHERATON
Model A275, Mahogany, Inlaid Plain, \$275.00

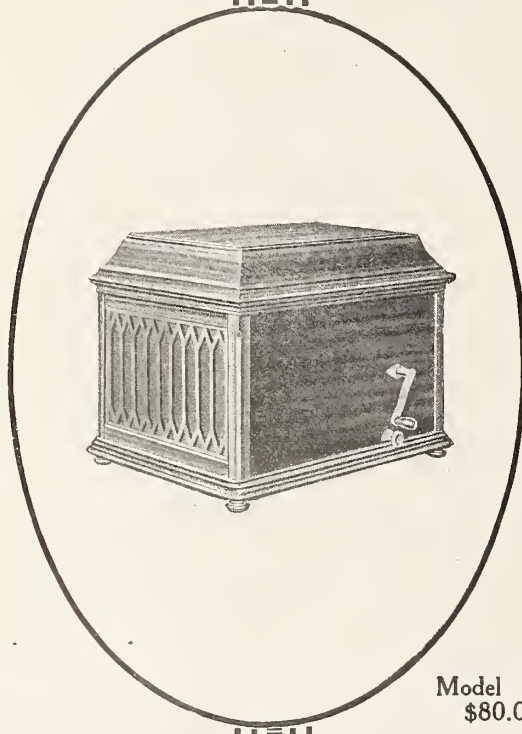

Model A80, Mahogany, \$80.00

Sell the Edison line because it meets every requirement, and—

because it more than satisfies every patron.

It isn't enough for you to carry a line of phonographs which will satisfy any one class of people. There is no profit in handling merely expensive instruments or merely those of moderate price. There is no satisfaction in selling a phonograph which finally gets over by the force of your talking ability, and which fails to satisfy later in the home because you aren't there to boost for it.

Thomas A. Edison, Inc.

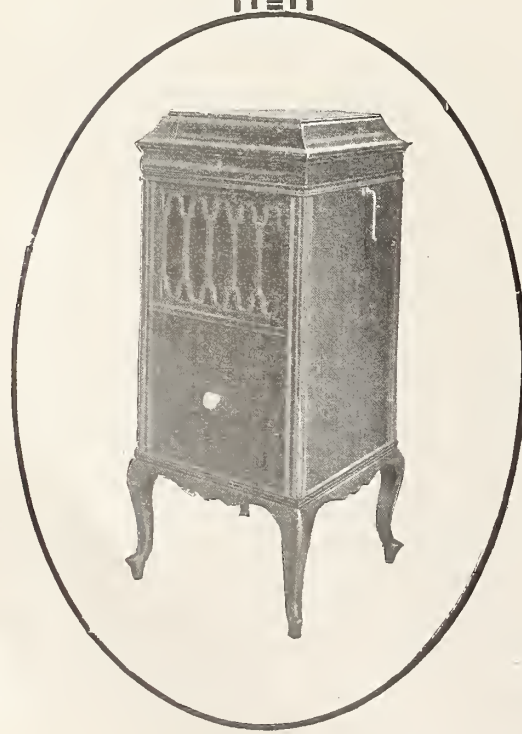

Model A200, Mahogany and Oak, \$200.00



Model A300, Circassian Walnut, \$300.00



SHERATON

Model A290, Mahogany, Inlaid Marquetry, \$290.00

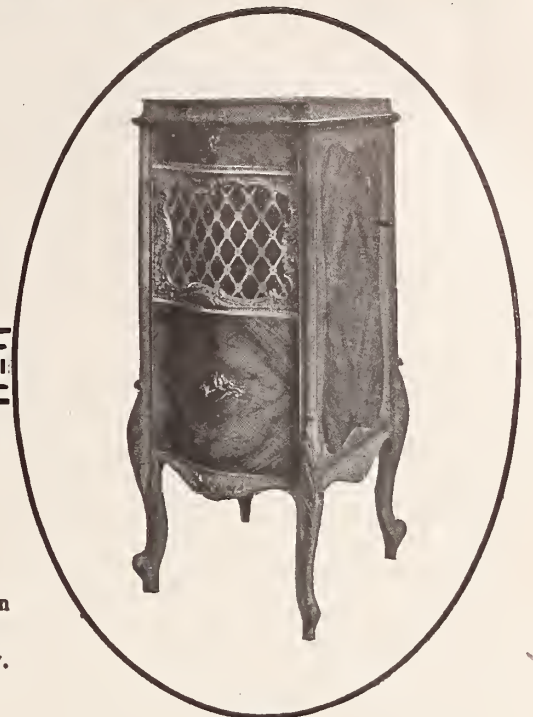

LOUIS XV

Model A425, Circassian Walnut, \$425.00
Model A375, Mahogany, \$375.00

Sell

Edison Disc and Cylinder Phonographs

because each one can speak for itself better than any amount of argument. Sell them for their clear, sweet, unique tone, their broad scope of repertoire, which is as broad as the history of music.

Sell them because their mechanical excellence will never send a purchaser back to you with a kick, because in the wide range of models there is bound to be not only one, but *two or three* which will suit any prospective buyer.

Sell them for their *musical superiority*, which has been a revelation to the most exacting music critics, and because you know that no matter how well informed a person may be, he will be *more than satisfied*.

You owe it to yourself to give your business the benefit of the best obtainable line. That line is the Edison. Ask your jobber.



Model B60, Oak, \$60.00



Model A250, Mahogany and Oak, \$250.00



Model A150, Mahogany and Oak, \$150.00

59 Lakeside Ave., Orange, N. J.

DEMAND IS FOR THE HIGHER-PRICED MACHINES.

Detroit Dealers So Report in Discussing Conditions for Past Month—Demand for Records Still Continues to Be Enormous Owing to Dancing Craze—Max Strasburg Co. Enlarges Department—Talking Machine and Automobile Businesses Most Active in City.

(Special to The Talking Machine World.)

DETROIT, MICH., March 9.—The past four weeks have been just wood-sawing time with the Detroit talking machine houses. There have been few noteworthy features, or incidents. February was better all along the line than was February of 1913. The dance craze seems to have been responsible for it. The business in records alone has been sufficient to keep everybody connected with the trade moving. All stores are short of records. On big orders only about 20 per cent. of the number asked for are delivered. Appeals to jobbers in all parts of the country have failed to bring relief.

There is a belief that this abnormal record business will remain a long time—but the belief is conditional. The business must be properly catered to by the manufacturers. The dance records must be perfectly made; must have the right tempo and the right tone. Otherwise they won't sell. Even the slightest imperfection will render a record a "dead one."

The cause of the "dance craze" is simply the opportunity for it, the dealers all agree. "For the first time in their lives, people have an opportunity to dance in their own homes," said Max Strasburg, of the Victrola Shop. "This goes for the wealthy as well as the classes, because while the owners of mansions have had ballrooms in them ever since dancing came into vogue, they have not always had the orchestra with them. They could dance in their homes, but not always just when they took a fancy to. The talking machine has made it possible to transform an ordinary social call into a dancing party on the spur of the moment. I think the new custom will continue for three or four years as a fad, and for a much longer time as a common practice—until science evolves something superior, in fact."

The demand for records is causing all the downtown dealers to plan enlargements of their record filing accommodations.

The visit to Detroit of the "Bird of Paradise" theatrical company has caused a demand for the Hawaiian records put out by the Victor Co. that has practically cleaned out the supply. These records have been very popular ever since their appearance about a year ago, and for that reason large stocks of them have been carried. The new impetus is bound to make them more popular than ever. "I could sell a thousand of them in a week, if I could get them," said one dealer.

The trade in Detroit still sticks to the higher-priced machines, generally speaking. Grinnell Bros., as Victor jobbers, have had considerable call from country points, and from outlying Detroit stores, for the cheaper machines, and just at present are pretty well cleaned out of all grades below the \$75 ones. The Max Strasburg Co. and the J. L. Hudson Co., on the other hand, no longer pay more than passing attention to the lower priced machines. If a patron desires one, they will obtain it for him. But primarily, they offer the large machines, and tell why they are worth the price.

Two Detroit influences which have been supposed to affect all sorts of business quite noticeably, have had no visible effect at all on the talking machine business. One of these is the unusually large number of unemployed here this winter. Very few men who have purchased talking machines have missed payments with the explanation that they were out of work. There has been no diminution of sales, such as would be certain of the problem of the unemployed had reached a vital stage. This fact tends to prove a theory now quite generally accepted that the most of the unemployed in Detroit are men who were lured to the city by stories of Detroit's great prosperity, and especially by the story of Henry Ford's munificence in declaring a ten million dollars' dividend among his employees.

The Ford announcement is in itself the other influence. Undoubtedly the talking machine merchants are making some sales directly because of the five dollars a day minimum wage now in effect in the Ford plant. But there is no flood of such business. Perhaps the talking machine business is so good that the influx is not noticeable. Not since the summer of 1911, almost three years ago, has there been a dull spell in the talking machine business in Detroit. The constant increase has been so steady and big that it has come to be accepted here as the normal condition. So even a big swelling of sales through Ford channels would be regarded as nothing out of the ordinary.

At the same time, it is realized by all the dealers that the Ford employees are not being put on the advanced scale payroll without investigation as to their habits and domestic policies. Ford's agents let it be known to the employees that thrift is the principal thing that is expected of them, aside from efficient work, and that "thrift" means either a savings bank account or an investment in

real estate. This naturally militates against the purchase of talking machines by the employes until they have nest eggs saved up.

The Max Strasburg Co. has just completed a rearrangement of record racks by which room for ten thousand additional records has been provided. This company now carries in stock about thirty thousand records, constantly. The company will establish a motor car delivery of its own within a few days.

The company has been trying, ever since it took on the Columbia line more than a year ago, to obtain more space adjoining its store, but has been unable to do so. It has been decided to take basement space, in lieu thereof, and a contractor is now figuring on how to make an underground palace of the downstairs floor turned over to him. About five more demonstrating rooms will be built.

The original store has been redecorated and the demonstrating rooms fixed up with beamed ceilings.

Oliver Jones, credit man of the Victor Co., was a visitor in Detroit the week of March 1.

NEW UNION REPRODUCERS

Made by the Union Specialty & Plating Co. in Great Demand—Plays Edison Records on Victor and Columbia Machines.

(Special to The Talking Machine World.)

CLEVELAND, O., March 9.—One of the busiest factories in Cleveland is that of the Union Specialty and Plating Co., principally engaged in the manufacture of Union phonograph specialties. H. B. McNulty, general sales manager of the company, said:

"Business is fine and the prospects are better. Since bringing out our new sound box, it is meeting with universal favor. We are receiving numerous and large orders for both the new sound box and the Union No. 1. We are now employing twice as many people as we did last year, and all are busy as bees. We have installed a jewel department for manufacturing jewels, both diamonds and sapphires, and will have something new for the trade from this department before long. Our business is growing so, and has grown to such an extent, we were compelled to lease the adjoining building, giving us about 8,000 square feet of floor space.

"We are starting an advertising campaign, in conjunction with the Talking Machine World, in quite a few magazines, on our new Union reproducers, No. 2 and No. 3, for playing Edison records on Victor and Columbia machines, as we wish to call the peoples' attention to their fine reproduction with diamond points."

The DITSON Pledge

Is to see that our clientele has a better service than ever—setting a new standard in Victor jobbing deliveries. The demands of alert Victor dealers—the kind that grow—are many and varied, and we furnish the "first-aid" in every instance.

We believe this year's Victor business will be of tremendous proportions, and it will pay you to have

The Fastest Victor Service

which is a requisite in this hustling age. We possess the largest stocks, the best organization and most up-to-date equipment in the Eastern half of the country.

This covers Victor machines, records and supplies of every kind, not to mention cabinets, needles and trade-marked accessories.

Will you let us tell you more about Ditson co-operation? A postal gets this information!

OLIVER DITSON CO., Boston, Mass.



The "Leader" at \$75 has quality—quality of appearance, quality of workmanship, quality of tone. That is enough to ensure a market for this Columbia instrument.



(Write for "Music Money," a book "full of meat" for those dealers interested in quick and frequent turnover of capital.)

**Columbia Graphophone Company
Woolworth Building, New York**

NEW DEALERS IN INDIANAPOLIS.

E. L. Lennox Piano Co. Added to List of Victor Dealers in That City—To Appoint New Retail Representative for the Edison Disc Line Which Is Proving Very Popular—Record Shortage Still Exists—General Business Excellent and the Prospects Are Splendid.

(Special to The Talking Machine World.)

INDIANAPOLIS, IND., March 6.—Plans are being made by the Kipp-Link Phonograph Co., 345 Massachusetts avenue, jobber for the Edison machines, to place Edison departments in three or four of the large music houses and department stores of Indianapolis. Up to this time the Edison machine could be only obtained at the Kipp-Link store but that is to be changed.

The demand for the new Edison disc machine is growing every day, and with the opening of branch departments in the downtown stores it is expected that all of the public will become better acquainted with Edison's latest masterpiece. Business with the Kipp-Link Co. is rushing.

Walter E. Kipp, of the Kipp-Link Co., in a talk with the representative of The World, asserted that the growth of the talking machine business to him was simply wonderful. While the talking machine is regarded as a luxury by many, said Mr. Kipp, still it becomes a necessity in the relief that it affords the workers of the city and the country.

We have with us another music house handling the Victor talking machine—the E. L. Lennox Piano Co., 311 North Pennsylvania street. This makes the seventh spot in Indianapolis where Victor talking machines and records can be had. Notwithstanding the number of places where the Victor machine is on sale, all are doing as much business as they can look after, that is, as much business as they can take care of with the limited number of machines and records. All are crying for more, more, more!

W. S. Barringer, of the Stewart Talking Machine Co., was scratching his head gazing ruefully at an order before him when the writer called on him. He pointed to a short order for twenty-five records. One half the records were out. "That's the way it goes," declared Barringer, "we simply can't get the records to take care of the business."

A. W. Roos, of the Columbia Graphophone Co.'s local store, is happy over the acquisition of a large block of wholesale territory in central Indiana. The Indianapolis store has not had any wholesale territory up to this time, and Roos was "itching" to get into the wholesale field. Twenty-five counties surrounding Indianapolis have been allotted to this district for wholesale territory.

Mr. Roos predicted some time ago that business in all lines would pick up after the first of the year, and he says he knows his prediction is true as far as the talking machine business is concerned. Dance records continue to be in demand and the Columbia records, which have been made especially for the dancers of the tango, hesitation and other modern day dances, are sought after to the extent that the shelves are often empty.

H. L. Willson, of New York, assistant general manager of the Columbia Graphophone Co.; W. C. Fuhri, of Chicago, district manager, and T. D. Westerveldt, superintendent of the Dictaphone agencies, were recent visitors to the Indianapolis store.

Thomas Devine, in charge of the Dictaphone business in Indianapolis and surrounding territory, has been spending considerable time outside Indianapolis building up a large Dictaphone business.

A "speechless" banquet will be a feature of the convention of the central division of the Associated Advertising Club of America which will be held in Indianapolis April 9, 10 and 11. The banquet also will be without a "headache," for the general committee in charge of the arrangements for the convention has ordained that no drinks are to be served. The banquet will be served at the Claypool hotel where the convention will have its headquarters. The banqueters will be entertained by vaudeville stunts, and who is there, who says that will be worse than speech-making? Advertising experts will be brought here to address the convention.

NEW QUARTERS IN WINNIPEG.

Winnipeg Piano Co. Holds Formal Opening of New Building in That Live Canadian City—Handsome Grafonola Department a Feature.

(Special to The Talking Machine World.)

WINNIPEG, CANADA, March 7.—Interest in matters musical cannot be said to be on the wane at all in Winnipeg, judging by the enormous crowds that attended the formal opening of the Winnipeg Piano Co.'s new piano and music store. The orchestra, vocal quartet, and soloists assisting had a very large and appreciative audience, and many flattering remarks greeted their efforts.

Numbers of old friends were in evidence, congratulating the two proprietors, John Smith and A. E. Grassby, on having been able at last to make the change of stores so long desired, which all goes to prove that business conducted in a businesslike way, is bound to succeed, especially in a country of such promise and opportunity as Western Canada.

Starting in their old store in Manitoba Hall over ten years ago, with only one line of pianos, this house has certainly made great strides, as is evidenced by their new quarters, and their many lines of high grade pianos, including the following exclusive agencies: Angelus, Autopiano, Bechstein, Bell, Chickering, Gerhard Heintzman, Gourlay, Haines Bros., Sherlock Manning, Smith & Barnes, and the Columbia line of talking machines.

For several years since their business overtook the capacity of their old store, the Winnipeg Piano Co. has in vain tried to secure suitable quarters, but when the Canada Furniture Co. moved from its big store at the corner of Hargrave street and Portage avenue, the Winnipeg Piano Co. was not slow to take advantage of this, the finest store in the city without exception.

The interior of the store is very attractively laid out, a large mezzanine floor having been built at

the rear to afford several beautiful Grafonola parlors above and piano parlors beneath, so as to avoid the necessity of taking patrons into the basement.

The Winnipeg Piano Co. is well known as the largest Columbia retailer in Canada and now that it has seven Grafonola parlors instead of three only, under the management of Joseph Tees, it will no doubt give a better account of itself than ever before.

Separate departments are provided for player-pianos and a large player roll library.

The smaller musical instruments and sheet music departments are in the capable hands of Mr. McLaskey, and it is probably unnecessary to add that the very best of attention and service can be relied on.

VICTROLA WIRELESS RECITAL.

A Novel Entertainment Prepared for the Patrons of the Famous & Barr Store in St. Louis Caused Much Favorable Comment.

The Famous & Barr Co., St. Louis, Mo., provided a novel entertainment recently for its patrons in the nature of a Victrola wireless recital. The wireless Victrola was created by combining the wireless telephone and the Victrola. Music was transmitted from the Victrola department on the sixth floor to the women's rest rooms on the fifth floor. The latest Victor records were played to the delight of the listeners. It is intended to continue the demonstration. The receivers in the rest room are attached to the chairs and davenport, and the music being played on the floor above is plainly heard. The receivers are small and simple and can be concealed on parts of furniture.



Write today for our new catalogue giving you rock bottom prices of our specialty.

Springs for any kind of Talking Machines

No doubt you will find it interesting.



EMIL RIEDEL

Sächsische Sägen- u. Federstahlwaren-Fabrik.

Chemnitz-Gablenz, Postfach 10, Germany

The **TALKING**
For the makers & sellers of talking machines **MACHINE**
WORLD

EDWARD LYMAN BILL, - - - Editor and Proprietor.

J. B. SPILLANE, Managing Editor.

Trade Representatives: GLAD. HENDERSON, C. CHACE, L. E. BOWERS, B. BRITAIN WILSON, A. J. NICKLIN, AUGUST J. TIMPE, L. M. ROBINSON.

Boston: JOHN H. WILSON, 324 Washington Street.
 Chicago Office: E. P. VAN HARLINGEN, Consumers' Building, 220 South State Street.
 HENRY S. KINGWILL, Associate. Telephone, Wabash 5774.
 Philadelphia: R. W. KAUFFMAN. Minneapolis and St. Paul: ADOLF EDSTEN.
 San Francisco: S. H. GRAY, 88 First St. Cleveland: G. F. PRESCOTT.
 St. Louis: CLYDE JENNINGS. Cincinnati: JACOB W. WALTER.
 London, Eng., Office: 2 Gresham Buildings, Basinghall St. W. LIONEL STURDY, Manager.
 Representatives for Germany and Austria: VERLAG NEC SINIT, Berlin C. 19, Ross-Strasse 6, Germany. GEO. ROTHEISSER, Director.

Published the 15th of every month at 373 Fourth Ave., New York.

SUBSCRIPTION (including postage), United States, Mexico, \$1.00 per Year; Canada, \$1.25; all other countries, \$1.75.

ADVERTISEMENTS: \$3.00 per inch, single column, per insertion. On quarterly or yearly contracts a special discount is allowed. Advertising pages, \$100.00.

REMITTANCES: should be made payable to Edward Lyman Bill by check or Post Office Money Order.

NOTICE TO ADVERTISERS.—Advertising copy should reach this office by the first of each month. By following this rule clients will greatly facilitate work at the publication headquarters.

Long Distance Telephones—Numbers 5982-5983 Madison Sq.
 Cable Address: "Elbill," New York.

NEW YORK, MARCH 15, 1914

OUR attention has been drawn to a recent article appearing in the columns of a daily paper published in southern Illinois, in which a prophesy is made of the triumph of the talking machine over the piano as the instrument of the home.

This is simply another case of the uninformed going off at half cock—just another of the many absurd statements which are made in the columns of the daily papers concerning special industries of which the writers are in total ignorance.

Such a prophesy is absurd, and the writer probably has not even a superficial knowledge of the fundamentals of either of the industries to which he referred in a prophetic manner.

The growth of the talking machine industry in this country has been one of the most remarkable developments which has occurred in any trade, and it is probably natural to suppose that a lot of writers and business men will be free to make all kinds of predictions regarding its future.

If a piano merchant finds business dull and he finds his more enterprising neighbor is doing business, who, by the way, may handle talking machines, he attributes the slowness of trade with him to the talking machine, and when a newspaper man drops in he is liable to say that the talking machine is cutting out pianos, and so, perhaps, the writers are not wholly to blame when they make ridiculous prophecies concerning the future of musical instruments.

THE talking machine has become, within a very brief time, such a great factor in the musical life of the nation that many people are apt to make most ridiculous comments regarding its future without taking the time to investigate just what effect it may have upon the sale of other musical instruments.

We recall the time when some of the old piano manufacturers figured that long before 1900 the entire population of America would have been supplied with pianos and all of the factories would be put out of business by reason of lack of demand for instruments.

That was the limited vision with which many men contemplated the piano horizon years ago.

What is the result?

More pianos are being made and distributed than ever before, and it is reasonable to suppose that a population of 100,000,000 has an absorptive piano capacity of 300,000 pianos annually.

Now, let us take up the question as to the serious invasion of the talking machine upon the piano field, and how much it has reduced the demand for pianos.

Of course, there are instances where people of limited income debate seriously as to whether they will purchase a piano or a talking machine.

It is admitted that the talking machine has many features of attractiveness. It supplies a variety of music which no other creation of human brain and hand can supply, but still it creates a demand for something more. It awakens a true musical spirit, and every talking machine which is sold is simply carrying on educational work for a greater demand for music, just the same as pianos wherever placed are adding their share to the musical love of our people.

DOES anyone for a moment suppose that the talking machine business could have reached the position which it has achieved within such a brief time were it not for the educational work carried on through the mediumship of the piano in former years? The demand for music has been stimulated by the sales of all musical instruments.

We are inclined to the belief that the piano market would be lessened if the talking machine were removed entirely from our modern life.

Why?

Simply because there would be a lessened desire for music, and piano manufacturers and piano merchants would have to work just so much the harder to instill the love of music into their clientele.

The facts are that piano and talking machines are both powerful developers in stimulating a love for music in the home circle, and when a customer shows an uncertainty as to which instrument he will purchase it is simply an incident in our business life.

A good many piano merchants find that customers from time to time make inquiries in their stores for talking machines, expecting to find them therein. The inquiry is natural, because it is logical to associate the talking machine as a musical instrument with houses which deal in all kinds of musical accessories.

THERE are more people who look in a music store for talking machines than in exclusive talking machine stores; but so far as the talking machine itself curtailing the sale of pianos by acting as a deterrent force is too absurd to seriously contemplate for a moment.

The statement, too, has been made that the sale of talking machines has decreased the sale of what we colloquially term small goods. In other words, musical instruments of lesser value than pianos, and yet inquiry at the great music trade emporiums in the principal cities brings forth the information that the stores which are thoroughly progressive are selling more banjos, mandolins, guitars, accordions, etc., than before for years.

To our minds, this increased demand for musical instruments has come largely through the influence of the talking machine in cultivating a love for music in many ways.

To illustrate: a person who owns a talking machine puts on fine banjo, violin or mandolin records. The audience listens to them with pleasure, and as a result of this kind of educational work some of the listeners will visit nearby stores and make purchases of instruments so that they can themselves learn to play upon them. Here is where the great educational power of the talking machine comes in. It places the finest music of the world within reach of all.

The world's greatest singers and instrumentalists are, through the agency of the talking machine, brought directly into the home circle.

If we had a great catalog of world renowned piano solos and selections it would increase the sales and interest in that instrument just as the vocal talking machine records have given hundreds of students to music teachers, who have personally admitted that their pupils have been encouraged to take up the higher study of music simply by the talking machine arousing ambitious instincts within them.

THE men who claim that the talking machine is seriously affecting the piano business have not carefully studied the fundamentals, because the demand for pianos is steadily increasing, and with the growing advent of the player-piano a new factor has been introduced which will still further make for healthy progress.

Again, there is another point which is well to make in this

connection, and that is that the talking machine has proven a splendid aid to piano merchants everywhere, because it has enabled them to make quick and easy profits. It has helped them to tide over trying financial conditions and has been the means of drawing customers to their stores who would not have purchased pianos, and it has helped them out very materially in the financial showing of their business.

After all, perhaps, the criticism that the talking machine has interfered with the piano business is quite natural when we consider that the talking machine as a selling force has broken all records.

It has come within a few years and is to-day conceded to be a powerful factor in the musical life of the nation; but its stimulating musical features, however, are not wholly understood or appreciated by those who thoughtlessly criticise.

The talking machine is helpful in many ways to the musical business, and piano merchants as a whole are not slow in giving to the talking machine fair credit for the success of their business. There are, of course, some few who allege that it has curtailed piano sales, but these are the ones who are uninformed and who usually lack ability to successfully conduct their own enterprises.

THERE is no trade or business that is completely lacking in sentiment, whether it be the making of carpet tacks or the manipulation of stocks. The man who is engaged in trade sees something before him besides the mere making of so much more money, especially if he has sons to whom he desires to leave a business that is sound in every particular. The matter of tradition in business is recognized as a valuable asset by thousands of business houses who boast of the fact that the business has been handed down from generation to generation, and has always been in the family. And yet, with all the value of the family name, there is something in being the pioneer, the man who entered into a new field, conquered and built up something to leave to posterity.

A prominent talking machine dealer, in discussing trade questions, the other day remarked that he had just taken his son into the business with him, and stated it as his belief that the talking machine business was the only one of its extent and stability in the country wherein immense jobbing and retailing houses had been built and yet had not marked the passing of a single generation. The head of practically every talking machine house of the present day, stated the dealer, is a pioneer, a man who, whether well equipped or not, took advantage of the opportunity to carve out his own career in a new and untried field. In a business that, as a commercial proposition, has not seen the passing of two decades, the credit for business ability and the success of the particular enterprise belongs to the man whose name is over the door.

A large number of the talking machine men have taken their sons into the business with them in the firm belief that the best days of the business are yet to come and that there is a real career in the field for the young men after the founders of the business have passed away.

The next generation may see the trade rise to its uppermost

pinnacle of importance or may see it dwindle, but in meeting the conditions as they come to light they will have the advantage of the experience of those who were in the business before them, an advantage that the talking machine man of to-day didn't enjoy.

SPEAKING of credits in commerce, Charles D. Joyce, of Philadelphia, recently made some remarks of interest and exceeding pertinence when he said: "No risk should be accepted, no project should be furthered without investigating the character, capability and capital back of that risk or that project. When all three of these essentials are satisfactory, aid should be liberally extended. But if a man has the two greatest assets of character and capability, of capital he may have little or none, credit supplies its place. Money seeks labor, and all it asks is that the laborer shall double the talents furnished him. He dares not be slothful or afraid, his *all* depends upon his integrity, his diligence and his originality. Thinking *after* other men never puts him first. The trader, like the poet, must have a vast imagination, he must see into the future, must have his ideal, must have faith in its realization, and then work for it without ceasing.

"The captains of industry to-day are the men who, a quarter of a century ago, read between the lines and saw the possibilities of the future, and then took advantage of those possibilities.

"The practical man 'prone to value none but paying facts' has been a blessing to civilization and to Christianity. Not only has commerce chartered the sea and opened up the wilderness, but it has through the successful prosecution of its own work also exercised a civilizing and uplifting influence."

THE newly-enacted currency statute will not let down the bars so far as credits are concerned, as many people have stated, and some very pertinent remarks of interest to the trade were made recently on the subject by W. C. Cornwell, an authority, who said: "The class of paper available for rediscount at the Federal reserve banks must be of liquid character. The maturity of ninety days does not, of course, mean that only paper made for that length of time can be used, no matter for how long originally drawn.

"The tendency among banks, in order to be equipped with plenty of available paper, will be to encourage their customers to avoid renewals. Loans which are not liquid, even though well secured, will not be looked upon with as much favor. All this will, of course, tend to make the banking assets of the country sounder. And, too, the influence upon merchants and others, by encouraging promptness and more liquidity in financial arrangements, will, in the end, be beneficial for all business.

"There is some belief prevailing in regard to the new measure that it is intended, as it is called, to make credit easier. This calls up a vision of loosening up on the part of the banker as to the character of loans which will pass muster.

"Nothing of the kind is in contemplation and no such effect will follow. Credit is one of the functions which can only be safely determined on business principles, and legislation which attempts to make it unnaturally liberal, is sure to bring disaster. The bill does not affect the status in this respect. It only supplies greater facilities for extending safe credits."

Beka Records

IN ALL LANGUAGES OF THE WORLD

High grade selections in

German, English, Italian, Spanish, Portuguese, French, Swedish, Slavonic, Ruthenian, Danish, Norwegian, Russian, Polish, Hungarian, Bohemian, Rumanian, Tschechisch, Croatian, Servian, Hebrew, Turkish, Persian, Arabic, and seventeen different Indian dialects.

The cheapest and best machine on the market for \$2.50 upward

BEKA-RECORD AKT. GES., Berlin, S. O. 36 (Germany)

CATALOGUE IN FOUR LANGUAGES SENT FREE ON REQUEST



All over the country men and women, young and old, are still dancing—to Columbia Records. Why? They are the only authentic dance records made.



(Write for "Music Money," a book "full of meat" for those dealers interested in quick and frequent turnover of capital.)

Columbia Graphophone Company
Woolworth Building, New York

INTEREST CLAUSE IN INSTALMENT LEASES UPHELD

By Appellate Division of New York Supreme Court in Case Fought to Finish by Pease Piano Co.—Ruling of Lower Court Reversed—Decision of Importance to Talking Machine Dealers Throughout State Who Charge Interest on Instalment Accounts.

The talking machine trade as a whole will view with gratification a recent decision handed down by the Appellate Division of the State of New York in favor of the Pease Piano Co., of New York, in connection with a case that had been decided against them in the lower courts. The Pease Piano Co. also handles Victor and Columbia talking machines.

The Pease Piano Co. had asked for judgment in the Municipal Court against Mrs. Miriam Fiske for an unpaid balance of \$14 on a piano that was sold under a conditional sale for \$325, together with interest as provided for in the sales agreement, amounting to \$38. Mrs. Fiske was willing to pay the \$14, but refused to pay the interest charge, claiming that the company's contract was ambiguous. Judge Murray, of this court, decided in her favor regarding the interest clause, assessing the Pease Piano Co. with the costs of the action, directing that Mrs. Fiske pay only \$14, and not the amount charged for interest.

Deeming the point of issue an important one, the Pease Piano Co. immediately appealed and as a result received a unanimous decision in its favor. Judge Lehman, of the Appellate Division wrote the decision, which vitally interests all members of the trade, as the most successful talking machine dealers are fast realizing that an interest clause should be inserted in every instalment sale, in order to protect their own interests. Judge Lehman's opinion follows:

"The plaintiff delivered to the defendant a piano under a written agreement upon a printed form which provides that the plaintiff leases to the defendant a piano for a period of forty-five weeks at a rental of \$10 for the first month, and \$7 for each succeeding month. The contract contains also the following clause:

"And said company hereby agrees with Mrs. Miriam Fiske that if she shall pay said company the sum of \$325 with interest at 6 per cent. per an-

num on all unpaid balances, said company will sell said piano to Mrs. Miriam Fiske for that sum and give a bill of sale thereof and credit upon said price all moneys which have been received from said Mrs. Miriam Fiske as rent of said piano.

"It appears plainly, both from the contract and the parol testimony, that the contract was intended as a contract of conditional sale upon instalments, and the plaintiff now brings its action to foreclose its lien for the unpaid balance.

"The defendant has paid the sum of \$311, and the sole dispute between the parties is whether absolute title was to pass upon payment of the additional \$14, or whether the plaintiff is entitled to this sum plus interest.

"The rights of the parties must be derived from the written instrument, and even the oral testimony admitted without objection must be disregarded if it is in conflict with the plain terms of the written contract.

"The contract clearly provides that the title to the piano was to pass only upon payment of the sum of \$325 with interest at 6 per cent. per annum on all unpaid balances, and the words italicized by me are printed in black capitals across the page. The payment of 6 per cent. on all unpaid balances is part of the purchase price of the piano, and the only question of construction is as to the meaning of the words 'all unpaid balances.'

"The contract provides that the payment of \$10 and \$7 per month shall be the rent of the piano, but shall be credited upon the purchase price if defendant shall purchase the piano. Since the purchase price is \$325, the balance remaining unpaid at any time is that sum as diminished from time to time by the so-called rental payments, and the defendant can obtain full title to the piano only upon the payment of interest on these unpaid balances of the purchase price.

"Judgment in favor of the defendant should, therefore, be reversed with costs, and judgment or-

dered for the plaintiff foreclosing its lien of \$14 with interest at 6 per cent. upon all unpaid balances."

Francis C. Brown, 76 William street, New York, presented the case for the Pease Piano Co.

DANCING CRAZE REACHES SPOKANE.

(Special to The Talking Machine World.)

SPOKANE, WASH., March 6.—The dance craze found its way into the Northwest about three months ago. The Columbia Co. has been doing splendid national advertising on dance music and Willis S. Storms, manager of the local store has been backing it up with lots of good live copy in the local papers.

"The result has been positively phenomenal," said Mr. Storms. "In our entire history we never have done the record business that we are doing to-day. Everybody is dancing. The Columbia Co's store seems to be one of the central meeting places of everyone who is interested in dancing. Last Saturday evening we were visited by one of the 'shining lights' of the Methodist Church. There was dance music to be heard on every hand and it proved to be so contagious that when he left our store he had six tangos under his arm and we had his money in the cash drawer. Our dealers are also realizing the splendid profit that can be had from the sale of dance records, and they are certainly taxing us to our utmost capacity to keep them supplied."

THE SIX BEST SELLING RECORDS.

A rather pertinent suggestion was made recently by the well-known magazine, System, in discussing the selling of talking machine records when it said: "I would announce—as the bookstores do—the six best-selling records for the month. Many patrons cannot visit the free concerts of latest records, so they ask, 'What do people say about this selection?' I would inclose with every record sold a post card upon which the customer was asked to write his opinion of the piece. I would publish from time to time a summary of these opinions. They would make newsy advertisements, or would form an interesting window exhibit."

READY REFERENCE OF GENERAL SUPPLIES

DEALERS

Send for our "Trial Proposition" on the Regina Hexaphone—the latest and best paying popular priced coin-operated instrument for use in public places.

THE REGINA CO.

211 Marbridge Bldg., 34th St. and Broadway, New York City
Manufacturers of Regina Music Boxes; Reginaphones;
Coin-operated Mandolin Orchestrons; Vacuum
Cleaners and other specialties.

Mermod & Co.
505 Fifth Avenue New York

Manufacturers of
Talking Machine Supplies
Motors—Sapphire Points
Diamond Points a Specialty

Keep Your Record Stock with

THE
Pease
SYSTEM
TRADE MARK

Costs about \$2.00 for 250 records for 50 years
Send for 20-page catalog

THE SYRACUSE WIRE WORKS,
SYRACUSE NEW YORK

HARGER & BLISH SUPPLY GRAND OPERA IN DES MOINES.

Take Up Dates Left Vacant Through the Dissolution of the Canadian Grand Opera Company by Supplying Those Musically Inclined with Edison Phonographs and Records in Their Homes—Some Striking Advertising That Has Won High Praise.

(Special to The Talking Machine World.)

DES MOINES, IA., March 7.—Harger & Blish, the prominent Edison distributors of this city, wide-awake to every opportunity which helps to feature the Edison in a dignified and effective manner, have been adding to their fame as novel advertisers.

The Canadian Grand Opera Co., which disbanded in Denver, Col., and which was scheduled to give performances for three days in Des Moines, and for which there was an enormous ticket sale,

manner in which Harger & Blish are bringing it to the attention of the public of this city, as well as in Dubuque and Sioux City, where they also conduct establishments.

The "blow up" of the Canadian Grand Opera Co. gave the firm a splendid opportunity, for no one event was so much talked of for years, the subject being discussed in the news and editorial columns, as well as in the cartoons in the local papers, showing how the appetite of the musical people of Des Moines had been whetted for grand

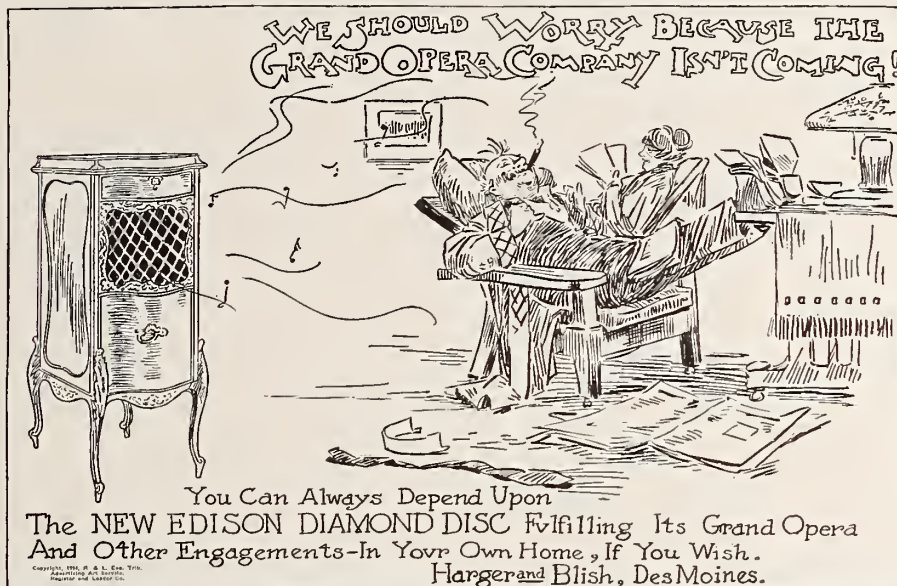

Harger & Blish Timely Advertisement That Caused a Veritable Sensation in Des Moines.

gave Harger & Blish one of those "psychological moment" ideas which resulted in the advertisement reproduced above, being conceived and published in the Register and Leader, two of our leading papers. It occupied a half page.

The pertinence of the advertisement to the situation aroused tremendous comment, and added another laurel to the rapidly increasing fame of Harger & Blish, as up-to-date advertisers.

Indeed, it would be impossible to conceive of any better means of concentrating attention on the new Edison disc phonograph than the progressive

opera, but Harger & Blish relieved the disappointment by notifying them that their wants could be supplied very effectively by means of the Edison disc phonograph.

Side by side with the preliminary advertisements of the National Grand Opera Co., Harger & Blish also carried advertisements emphasizing the merits of the Edison in a forceful way. The climax, of course, was the advertisement referred to above, which shows that the members of this company are alert to every development.

VERDI AS A PROPHET.

How He Came to Predict the Success of "Il Trovatore" by Interesting Test.

When Verdi was putting the last touches to "Il Trovatore," he was visited in his study by a privileged friend. The friend was one of the ablest living musicians and critics. He was permitted to look at the score and run over the "anvil chorus" on the pianoforte. "What do you think of that?" asked the master. "Trash!" said the connoisseur.

Verdi rubbed his hands and chuckled, "Now, look at this and this," he said. "Rubbish!" said the other, rolling a cigarette. The composer rose and embraced him with a burst of joy. "What do you mean?" asked the critic. "My dear friend," cried Verdi, "I have been making a popular opera. In it I resolved to please everybody except the purists, the great judges, the classicists, like you. Had I pleased you I should have pleased no one else. What you say assures me of success. In three months 'Il Trovatore' will be sung all over Italy."

VITAL FORCE THAT MAKES SUCCESS.

Some Remarkable Advertising by Curtis Publishing Co. in Public Ledger, Philadelphia, Cites Development of Victor Co. as Example of What Can Be Accomplished by Meritorious Products and Persistent Advertising.

Under the heading of "When these men can't afford to stop, can you afford not to begin?" the Public Ledger of Philadelphia, Pa., recently published a most interesting tribute to the success and remarkable growth of the Victor Talking Machine Co. In addition to presenting a forceful array of facts, this advertisement, which was inserted by the Curtis Publishing Co., owners of the Public Ledger, showed at the top of the page the small one-story building that marked the humble start of the Victor Co., as contrasted with a bird's-eye view of the present immense plant occupied by the Victor Talking Machine Co.

As illustrative of the advertising policies of the Victor Co., this page, which reads as follows, is well worth perusal:

"In Philadelphia there are ten or a dozen manufacturers to whom, every time they pick up a newspaper or magazine, the advertisement placed there by a fellow manufacturer just across the river ought to be a flaming rebuke.

"Some of those men will recognize, at the top of this page, the birthplace of the Victor Talking Machine Co.

"All of them will identify the picture below of what it has become—chiefly through wise employment of the power of advertising.

"The little sign over the door of Mr. Johnson's machine shop was his first advertising.

"To this shop, in 1894, was brought for his help one of the early experimental models of talking machine. It sounded, he says, 'like a partially educated parrot with a sore throat and a cold in the head.'

"Genius—or inspiration—sensed the possibilities latent in that crude device.

"Infinite perseverance slowly shaped it into a delicate musical instrument.

"But it was only a bold, unflinching faith that first took the lion's share of the capital of the little company and turned it into advertising.

"Faith in the product.

"Faith in human nature.

"That faith, justified, has never been lessened.

"During the financial score of 1907, when curtailment was the accepted program elsewhere, the executive board of the Victor company, without one dissenting voice, added \$267,000 to the year's advertising appropriation. They went through the panic and into 1908 facing a demand far in excess of factory capacity.

"In 1913 this company again made its heaviest investment in advertising and again had the biggest year in its history. In October alone its sales were \$1,200,000 greater than the preceding October.

"They say 'Our success has been built by advertising. Next to manufacture, it is our chief consideration. We can't afford to stop.'"



"DOLLAR" MOTORS

LATEST SENSATION—DETACHABLE SPRING CAGE

Without any dismantling of the motor, a NEW SPRING may be inserted within a few seconds.

Many patents both at home and in every civilized country applied for.

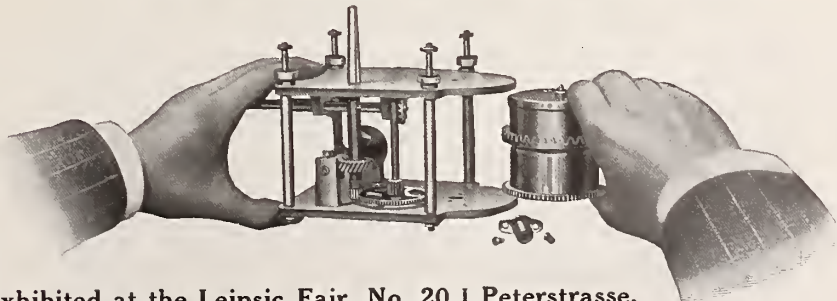

Exhibited at the Leipsic Fair, No. 20 i Peterstrasse, Hotel de Russie, Zimmer No. 6.

GEBRÜDER STEIDINGER, Fabrik für St. Georgen (Schwarzwald), Deutschland

Cable Address: Gebrüder Steidinger Sanctgeorgenschwarzwald.

ARE UNQUESTIONABLY THE BEST AND CHEAPEST

Our Export Catalogue in four languages, covering 30 styles of motors adapted for Talking Machines, sent free of charge, postage prepaid, for the asking.

Advantages of our Motors:

- Noiseless movement
- Supreme accuracy
- Highest grade of materials
- Greatest money value

THREE NEW EDISON ARTISTS

Make Their Debut in May List of Blue Amberol Records—These Include Albert Quesnel, Tenor; Merle Tillotson, Contralto; and J. E. Walbank, Tenor—Possess Charming Voices.

Albert Quesnel, who has sung with the Opera Comique, Paris, and the leading orchestra organ-



Albert Quesnel.



J. E. Walbank.

izations of Paris, London and New York, such as the Colonne, Lamoureux, Wood, Bridge, Darnrosch and others, with great success, heads three artists who will make their debut in the May list of Blue Amberol records issued by Thos. A. Edison, Inc. Mr. Quesnel is a tenor of authority and distinction and his singing of Jules Granier's "Hosanna" and Adolphe Adam's "Cantique de Noël" in French is an admirable recording of two great numbers. Mr. Quesnel's voice is of splendid range, volume and brilliancy which he uses like the trained artist he is. His records will be welcomed by users of Edison phonographs, for his fine artistry has won compliments from the critics of the leading papers in this country (where he has spent the greater part of his life, although born in France) as well as those of Europe.

James E. Walbank, who has had a long and successful career as a tenor singer in opera and concert, is the second newcomer in the Edison



Merle Tillotson.

list of May. His singing of F. W. Vanderpool's "In Dreams, My Own," a typical sentimental ballad, is most artistic in every way, and he is destined to become a favorite. The third new artist in the Edison May list is Merle Tillotson (Mrs. B. Alcock), who possesses a contralto voice of exceptional quality for recording purposes. Her singing of Sir Arthur Sullivan's classic, "Let Me Dream Again," is a delight, particularly for its clear, finished enunciation, a trait unfortunately too uncommon among our singers. This record will find a host of admirers as will the artist who made it.

ARTISTIC VICTOR DEPARTMENT

Feature of New Lord & Taylor Store Which Was Opened Late Last Month in New York—New Quarters Are Handsomely Fitted Up.

With the opening of the new Lord & Taylor store, on February 24, one of the most artistic Victor departments in the local trade was added to the imposing list of Victor dealers in this territory. Although Lord & Taylor had maintained a Victor department at its old store for some time prior to its removal to Thirty-eighth street and Fifth avenue, that department in no sense compared with the beautiful show rooms that now form a substantial part of the Lord & Taylor "Music Rooms" on the seventh floor of its new building. This Victor department is under the direction of the Musical Instrument Sales Co., the Lord & Taylor store being a member of the Clafin chain of stores.

Five large display rooms presenting all the popular types of Victors and Victrolas are devoted to the exclusive demonstration of machines, while five tastefully furnished smaller rooms are used



NYOIL

For polishing varnished woodwork it is extremely satisfactory. No oil is so clean.

Ask your watch repairer whose oil he uses on your watch.

only for the demonstration of Victor records. C. R. Wagner is head of this new department, and, assisted by an unusually capable sales staff, is already making sales records that would be gratifying as an excellent holiday business, instead of a spring trade.

LUMBER DEALERS ENJOY VICTOR.

(Special to The Talking Machine World.)

MILWAUKEE, WIS., March 5.—One of the leading features of the program offered at the annual convention of the Wisconsin Retail Lumber Dealers' Association, held at the Hotel Wisconsin, in Milwaukee, February 17 to 19, was a demonstration of a Victrola, from the attractive retail shop of Miss Gertrude F. Gannon. The lumber dealers were favorably impressed and it is pretty safe to say that many a Victor will be sold.

The Masterphone

GIVES

Perfect Detail

Rich Tone

Full Volume

Records remain perfect forever, as Victor Fibre Needles are used.

Your customers will like the Masterphone, for it adds immeasurably to the value of their instruments.

YOU EARN ADDITIONAL PROFITS.

Write for Sample and Discounts.

Steel
Needles
Masterphone
\$1.00

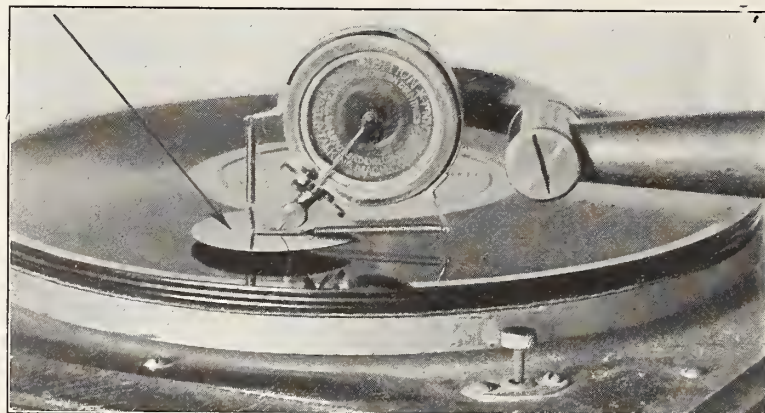

Fibre
Needles
Masterphone
\$1.50

THE MASTERPHONE CORPORATION, 187 Broadway, New York City
Telephone: Cortlandt 1872



Your customers are rapidly learning this—that all Columbia Records play on Victor Talking Machines just as Columbia instruments play all Victor records.



(Write for "Music Money," a book "full of meat" for those dealers interested in quick and frequent turnover of capital.)

**Columbia Graphophone Company
Woolworth Building, New York**

SINCERITY IS A SUBSTANTIAL BUSINESS ASSET.

Freedom from Hypocrisy, Disguise or False Pretense Essential in Order That Any Man May Rise to Eminence in the World of Trade—An Illustration from Personal Experience That Is Worthy of Close Consideration and Action Because It Points a Moral.

Are you sincere? Success and failure are very evenly balanced in the commercial scales these days, and it may take just a pinch of sincerity to send your business soaring to a greater and more lasting prosperity.

Sincerity means a great deal in the talking machine field. Your customers, if they can depend absolutely upon the integrity of everyone connected with your establishment, will deal with you permanently, and, very often, deviate from their several ways to do it. There is a certain satisfaction to be derived from trading with a chap who



"A Concert in the Home."

is honest. Honesty has many loopholes through which a business man may shoot poisoned arrows at his customers supposedly to his own betterment. He may achieve a small measure of success through this lawful dishonesty, if I may speak paradoxically, but he is sure to meet his Waterloo at last. His more fortunate fellow dealer, however, who takes sincerity for his motto, sails calmly onward toward wealth and happiness.

I am not sure I am making myself clear. What I mean to convey is this: Do not delve between the morocco covers of Blackstone to ascertain how far you can go toward skinning your customers and still remain an honest man. You will undoubtedly find innumerable recipes, but disregard them. Be sincere and you will not need to follow a crooked road to the land of promise.

A short while ago I happened to be walking on Bedford avenue, Brooklyn. Arriving at No. 1223, I found myself gazing in at the attractive window display of a talker shop. An artistically lettered card invited me within to hear "The new Edison Disc, the most wonderful Musical Instrument." I also discovered through the medium of the exhibit in the window that the Victor and Edison cylinder lines were also handled by this firm. As I had never made a careful comparison of the rival machines, face to face, I took advantage of the opportunity so agreeably presented and walked in.

A young fellow of good address came forward

and cheerfully inquired my business. I told him I had accepted the invitation in the window to hear the new Edison, and that I would like to go still further, if agreeable to him, and compare it with the Victor.

At the outset I wish it understood that I did not enter this store as a prospective purchaser; in fact, I made it plain that I was a mere investigator. Notwithstanding this fact, I was treated with the utmost courtesy during my stay, which must have filled at least an hour of time. I was made to feel thoroughly at home; was entertained by hearing the same selection by the same artist on all three machines, which, of course, is the only true test, and, during the entire competitive concert the superiority of one make of instrument over another was not discussed by my host.

By the way, I want you to know him. "Mr. Greenglick, gentlemen; a sales expert well worthy of your acquaintance."

I asked Mr. Greenglick why he did not eulogize one machine above another. "You have an individual preference, no doubt," I suggested.

"I do not consider it good business to do so," he answered. "You see, we handle all three machines, and if I should form an opinion as to which was the best, that same opinion might crop out at an inopportune moment, and, perhaps, spoil a sale or cause an old customer to become dissatisfied with his outfit, which is just as bad. I endeavor at all times to be absolutely sincere, which in my case, so far as the different makes of machines is concerned, signifies neutrality; I really have no choice. After demonstrating each instrument thoroughly, I leave the choice to the purchaser. And," continued Mr. Greenglick, after he had returned from an errand of salesmanship, "I really consider sincerity the keynote of success in the talking machine trade."

"Our customers are decidedly enthusiastic about the treatment they receive at our hands, and it is due largely to the fact that we never lie to them. We do not promise records before we can deliver them, and we do not claim anything of our wares beyond their capacity to make good. We are busy and prosperous and our business is moving in the right direction."

"And you attribute all this to sincerity?" I asked to make sure.

"Absolutely yes!" came Mr. Greenglick's answer, given most emphatically.

The above, Mr. Dealer, is a true example of what sincerity is doing for one very much alive talker man.

Is it doing as much for you? Very often the dealer himself may be sincere to a fault, careful in every possible way, so far as he is concerned individually, to act squarely and above-board with his patrons; but through the insincerity of, perhaps, just one of his employees, have his establishment acquire an unsavory reputation. There is

nothing, believe me, that will injure a business more quickly than false pretense. If a customer is trifled with in this regard a few times he loses confidence and hies himself to another store. Like the proverbial Steve Brody, he takes a chance. Rather than remain and suffer from dishonest business methods, he moves on. Can you blame him?

Did you ever visit a talker shop where sincerity is practiced in order that you might ascertain the state of mind of the patrons? I have done so, and the result proved a revelation to me. They invariably enjoyed themselves thoroughly, and their countenances were free from that hint of doubt which is wont to cloud the faces of those who frequent some talking machine emporiums. These people knew that they were being treated right, and they were happy in consequence. Their selection of records was left, in a large degree, to the discretion of the salesman, and this procedure



"Invariably Enjoyed Themselves Thoroughly."

showed good judgment on their part. Through his close association with the different kinds of music he could take their orders and cater to their tastes to the best advantage. A sincere salesman catalogues not only his customers' names but their tastes as well, and when they call upon him he is in a position to give them what they want, very often, without playing a single selection. Imagine the satisfaction and pleasure to be derived from a concert in the home where the listener is assured beforehand that the records are free from flaws and the repertoire an artistic triumph throughout.

I think it might be well, Mr. Talker Man, to give this matter of sincerity in trade your very careful consideration. There are a great many of you, I know, who already practice this fine art to the full, but to those who have thoughtlessly neglected to give it quite all the attention it deserves I would say, in closing, that if you will make up your minds to conduct your business along strictly sincere lines, and have your employes co-operate with you in the good work, your popularity among the folks who buy from you will increase by leaps and bounds.

The year is young yet. There is still ample time for the carrying out of good resolutions. Inscribe a card with the axiom "Be Sincere!" Place it conspicuously on your desk where your eyes will encounter it often. It may help you out of many a difficulty.

HOWARD TAYLOR MIDDLETON.

THE TRADE IN BOSTON AND NEW ENGLAND

JOHN H. WILSON, MANAGER, 324 WASHINGTON STREET, BOSTON, MASS.

(Special to The Talking Machine World.)

Boston, Mass., March 9.—With the extension of Avery street from Washington street to Tremont street, the one concern above others that will benefit by the new thoroughfare, is the Columbia Graphophone Co., for while the extension will take off a few feet from the side of the establishment, there will be a large gain through the splendid windows which the store will have for a distance of eighty-four feet, which is practically the depth of the store. This will give the Columbia unusual opportunities for the display of its machines and records, and it will keep Manager Erisman busy devising attractive window displays, something for which this store long has been more or less conspicuous. The city has not begun the work as yet, but will in a few weeks, and once it is under way there will not be any time lost in getting the job completed, and then the Columbia should blossom forth in its new glory late in the spring. Business with the Columbia has been of surprisingly large proportions and so large a stock is necessarily kept on hand that storehouse quarters have been taken on the third floor of the building at the corner of Chauncey and Essex streets, where 4,800 square feet of space are kept filled with equipments.

F. T. White with Harvey Co.

The C. C. Harvey Co., of 144 Boylston street, which heretofore has not especially forced its Victrola department, has started upon a new era, and it has appointed as the manager of this department, Francis T. White, formerly of the Henry F. Miller Co. Mr. White is familiar with the talking machine business and possesses many friends in the business. The department will always contain a complete stock of Victrolas and records, and Mr. White will pay especial attention to sending records on approval. This department of the Harvey Co., is comfortably fitted up and quite attractive.

Gilchrist Co. Takes on Columbia Line.

The Gilchrist Co.'s large store, which lately has come under new management, having become convinced of the value of a talking machine department, has installed Columbia quarters on the fifth floor, where 2,000 square feet of space are given over to Columbia equipments. There are three sound-proof rooms and from the start the department has been popular, and on the first day 159 different sales were made. The department is in charge of James C. Mason, brother of Norman

Mason, the indefatigable representative of the Columbia Co.

More Room for Talking Machines.

Two new rooms have been added to the suite occupied by George Lincoln Parker, of the Colonial Building, for his talking machine business, and although in use only a fortnight, they have already proved their usefulness, for Mr. Parker's business has been quite large in the past fortnight, and is growing fast. The manager of this department is John H. Alsen, a man of courtesy and ability. He lately has added to his staff Joseph Carlson, who is taking hold of the business most intelligently. Through a re-arrangement of some of the other rooms occupied by Mr. Parker, better facilities are afforded for the storage of discs, many new racks having been installed. These quarters, where one may find a large array of Victor, Edison and Columbia outfits, are among the best-equipped of any in the city.

How Gaby Deslys Was Entertained.

The dreadful storm which New York experienced the end of February, played its part at the Tremont street quarters of the Columbia Graphophone Co., for as Gaby Deslys could not play her engagement at the Shubert Theatre because of the non-arrival of her wardrobe and scenery, the passers-by were appraised of the situation by means of a big bulletin board in the window. The news was changed frequently according to latest advices from the environs of Camden, N. J., where the train bearing the paraphernalia was stalled. While she was in town, her opening performance having been delayed two days, she made her home at the Touraine, where she had a \$500 Grafonola grand to while away the time.

Harry Rosen in Back Bay.

Harry Rosen, whose School street quarters always are most popular with down town people seeking machines and records of either the Columbia, Edison or Victor types, has been so successful that he is going to branch out. He is negotiating for a stand in the Back Bay near Symphony Hall, which should prove a good center, as there is no talking machine store in the neighborhood. Further details will be announced in this magazine next month.

Important Edison Representatives.

Manager Silliman, of the Boston office of the Pardee-Ellenberger Co., makes a splendid report of business conditions, and he states that two of the strong concerns which have been signed up

through his office are the Cushman Furniture Co., at Attleboro, and the Allen Drug Co., at Hanover, N. H. This last is an especially important representation, as the demonstrations of the Edison disc machines have attracted many of the Dartmouth College faculty and students, with the result that numerous sales have been effected. Another connection which Mr. Silliman has formed is that of Fred W. Brown, of Plymouth, N. H. One of the recent callers on Manager Silliman was E. H. Dakin, of the S. L. Crosby Co., of Bangor, Me., one of the enthusiastic Edison dealers.

New Half-tone Needle Popular.

The Eastern Talking Machine Co. is having a wonderful success with its new half-tone needle, which it lately has put out, and of which nearly a million have been sold, so the store reports. Those who have tried it are said to be most delighted with it, especially as the scratching is minimized. Billy Fitzgerald says that the tango music has reached high speed at this store, and the demand for this type of music almost exceeds the supply.

Speaking of the tango, the "boys" of the Eastern company have been in great demand the past fortnight as teachers of this and other of the popular dances and the "Southport quartette, composed of Fitzgerald, Welch, Splaine and Reed, are getting to be real experts. If you want to learn more about their interesting experiences, just ask any of the boys.

To Concentrate on Pianos.

Charles F. Atwood, of the Walker Building, has given up his Victor representation, and hereafter will devote his time entirely to his piano business, in which he has been doing quite well since removing from his other quarters in Tremont street.

Edison Demonstration in Worcester.

H. R. Skelton, traveling man for Thomas A. Edison, Inc., who makes his headquarters when in Boston at the Pardee-Ellenberger Co.'s offices, has been spending a fortnight in Worcester, where he has been giving demonstrations of the Edison disc machines at the new Hotel Bancroft. He has been using a \$250 model, and many of the prominent people of the city have become interested in the proposition.

Visitors to Eastern T. M. Co.'s Quarters.

Visitors at the Eastern Talking Machine Co.'s quarters have been W. A. Condon, of New York, and Will Oakland, the famous counter-tenor, who has been signing at Keith's beautiful playhouse a few doors away. This singer records for the Vic-

THE main thing that you sell when you are an Edison disc merchant is music—real music—the kind of music that makes a man long to spend his evenings at home. This is the reason why so little salesmanship is required of Edison disc merchants, and low selling cost means big profits.

**P-E
SERVICE**



**P-E
SERVICE**

IT isn't even necessary that you should have any experience as a phonograph man, for part of our service to you is along educational lines in order that you and your salesmen may do the greatest amount of business. This is real service and co-operation that means results.

THE PARDEE-ELLENBERGER CO., Boston, Mass., and New Haven, Conn.

THE TRADE IN BOSTON AND NEW ENGLAND

JOHN H. WILSON, MANAGER, 324 WASHINGTON STREET, BOSTON, MASS.

tor people. While in town, he presented Billy Fitzgerald with a large photograph of himself, which now hangs over his desk.

Professor Miller Pleased.

The Eastern Company is in receipt of a letter from Professor Dayton C. Miller, thanking the company for its courtesy in loaning a Victor machine for his recent lectures at the Lowell Institute course, given at the Technology. Professor Miller found the machine most useful in illustrating his talks on "Sound Analysis," and in his letter he writes of the great value of these machines in scientific research work.

Steinert Force Augmented.

Herbert L. Royer, manager of the Victor department of the M. Steinert & Sons Co., who has lately taken on several new and valuable men, now has as carefully chosen and well-equipped staff as any talking machine establishment in the city. Mr. Royer, who is a man of progressive ideas, lately mapped out some of his prospective plans to The World correspondent, and if they are carried out, should mean a rapid advance in Victor business.

Compliments for Columbia from Maggie Teyte.

Manager Erisman, of the Columbia Co., is in receipt of a beautiful letter from Maggie Teyte, the opera and concert singer, complimenting the wonderful tones which the Columbia record is able to produce, speaking particularly of the reproduction of her own voice, and adding that "now every one has a chance of hearing my songs." While she was stopping at the Copley-Plaza, Miss Teyte enjoyed the privileges of the Columbia \$500 Grand, thanks to Manager Erisman's courtesy.

No Cut in Columbia Outfits.

Although the Henry Siegel Co. is in the hands of receivers and goods in all departments are being offered at bargain prices, there has been no cut in the Columbia outfits, which have occupied a large department on one of the upper floors of this large establishment. In the display advertisements of the house the talking machines are featured as before, but the regular prices are obtained.

Victor Quarters at Chickering & Sons.

The Victor department of Chickering & Sons has undergone quite a change since Retail Manager Currier has taken hold. Instead of being in the basement, the Victor-Victrola outfits may now be had in special quarters on the second floor, where the new manager, Wilbur W. Longfellow, is ready to greet his old friends. Mr. Longfellow has had wide experience in the talking machine business, having been for four years with M. Steinert & Sons, where he handled much of the outside work.

Joins Henry F. Miller Forces.

Warren A. Batchelder, widely known in the talking machine business, is back at the old stand, having returned to the Henry F. Miller Co.'s house, where he now is manager of the Victor-Victrola department, of which he was in charge before associating himself with Chickering & Sons, nearly two years ago. Friend Bakér and Frank H. Jenkins complete the trio of hustling Victrola enthusiasts.

REPORT A LARGE BUSINESS

In the Thomas Attachment Which Enables the Owner of an Edison Disc Phonograph to Play Perfectly Records of Any Make.

(Special to The Talking Machine World.)

BOSTON, MASS., March 9.—Dealers have been quick to recognize the value of the new Thomas attachment which is made for the new Edison disc machines, to enable the owner to play records of other manufacture. The Thomas attachment, which is the invention of Chas. P. Trundy, is being manufactured and distributed by the F. H. Thomas Co., 689 Boylston street, this city, a concern of standing which some time ago added a phonograph department and now is one of the leading talking machine dealers in New England.

In chatting about the Thomas attachment, notice of which appears elsewhere in this issue, Chas. P. Trundy, the inventor, said: "The special feature of it is the ball bearing 'joint,' which permits a free and flexible lateral motion without the aid of a mechanical feed. The reproducer joint is of peculiar formation, and is built to allow 'up and down' play,



Charles P. Trundy.

taking care of inequalities of recording or warping of the record. The device is made of cast brass with a five-eighth inch core. It reproduces the full tone and is giving excellent satisfaction to the trade."

EDISON DISC SHOWN IN NEW HAVEN.

New Machines and Records Demonstrated with Great Success in Progressive and Live New England City by J. W. Scott—Supervisor of Music of City Schools Enthusiasm Over Musical Qualities of New Product in Letter.

(Special to The Talking Machine World.)

NEW HAVEN, CONN., March 10.—Among the demonstrations of the Edison disc machines, one in this city has been creating the greatest interest. It

is being conducted by J. W. Scott, the well-known Edison traveling man and the palm room of the Hotel Taft is crowded at every recital. Among the audiences one may see many of the Yale professors and their families. One of the pleasant results of the demonstration has come in the form of a testimonial letter, sent to the A. B. Clinton Co., 33 Church street, New Haven's oldest Edison retail dealer, from Professor B. Jepson, supervisor emeritus of music in the New Haven schools. Professor Jepson writes:

"I must confess that I was never more taken aback in my life than I was at the close of the Chamber of Commerce lunch at the Taft last Saturday. At the close of the lunch a beautiful soprano voice launched into a solo. I was not surprised at that, but very much surprised as I looked around the room in vain for the soloist. I supposed, of course, that I would find the lady in the center of a group of men gathered at the rear end of the room. I was really astonished to find that the beautiful voice emanated from a phonograph. To sum it all up, I must say that Edison's new diamond disc phonograph is the 'last word' in the rendition of vocal or instrumental music."

FIRE IN MONTPELIER.

Bushwell's Book Store Badly Damaged—Loss \$10,000—Temporary Quarters Secured.

(Special to The Talking Machine World.)

MONTPELIER, VT., March 9.—Buswell's Book Store, which suffered severely from the flood a year ago during the spring freshets, has again undergone a loss, this time from fire. A fortnight ago a fire was discovered in the building, and before it was extinguished the store was badly damaged. During the progress of the fire there was considerable playing, but it was by the hose and not by the records, hundreds of which were destroyed as well as some valuable machines. The store's loss was figured at \$10,000, on which there was an insurance of \$7,500. Mr. Buswell immediately after the fire secured temporary quarters near his old location, and in the meantime the burned structure will be rebuilt and in a few months Mr. Buswell should be installed in more beautiful and convenient quarters than before.

Skilled Workmanship Costs More In BAGSHAW-MADE Needles

FROM the time the steel enters our factory (made according to our exact formula), it goes through the various processes in the most efficient manner. Most of the work is done by machinery, but the pointing of the steel before it is cut off into needle lengths is done by skilled workmen.

It is this personal attention to making needle points that gives the quality touch to Bagshaw-made needles, and you can prove the value of this statement by playing Bagshaw-made needles in comparison with needles of any other make.

If you don't know Bagshaw-made needles, we'll send you a package for your personal use. Larger quantities may be obtained through your jobber.

Established 1870

Pioneer
Needle Makers

W. H. BAGSHAW
Lowell, Mass.

R. NEWTON JONES' CLEVER WORK.

Takes Advantage of Visit of Arthur Friedheim, and This Famous Pianist Listens to His Own Columbia Records in Mr. Jones' Store.

One of the most enterprising dealers on the books of the Columbia Graphophone Co. is R.

As indicative of Mr. Jones' policy of up-to-date-ness, the advertising department of the Columbia Co. recently received from him the interesting photograph shown in the accompanying illustration.

In this picture Arthur Friedheim, the prominent pianist, is shown listening to one of his

sion houses and commercial bankers in New York are doing a legitimate business and that they are, in fact, a benefit to the business community. It was explained by counsel that the proposed bill had been drafted to help the commercial bankers and credit men and was aimed directly at those who solicit the secret assignment of accounts on the eve of a failure. The committee also approved the proposed amendment made to the Bulk Sales law, introduced into the Legislature by Assemblyman Horton, at the instance of the National Association, which seeks to make the present act in this State more on the order of the statute in Michigan, which has been held constitutional by the courts.

HORN MACHINES STILL POPULAR

In Australasia and Demand for Hornless Types Has Had No Serious Effect on Sales—The Views of S. J. Jackson, of Sydney, N. S. W.

We have become so accustomed to talking machines of the hornless type in this country that it is interesting to note that in other countries the talking machine with the horn is still a factor of importance and decidedly popular with buyers. This is true of many countries in Europe, but more particularly is it true of Australia. S. James Jackson, of Jackson & Macdonald, Sydney, N. S. W., who rank among the largest wholesalers of talking machines in Australasia, in writing *The World* recently, remarked:

"Up to the present the hornless talking machine has had no serious effect on the sale of horn type machines in Australia, but this is possible because the bulk of the disc machines sold are of European manufacture, and until the litigation regarding the Holzweissig patents is definitely decided there will be some restriction in the manufacture of hornless machines."

As a consequence of the conditions in Australia there is a great demand for horns, and many inquiries are reaching *The World* office for the names of manufacturers who can supply our friends in the Antipodes.

Australians have long been ardent supporters of the talking machine, and few countries outside of the United States, population considered, have been larger purchasers of records and talking machines. The people are most musical and are keenly appreciative of the remarkable advances made by the manufacturers of the United States in presenting such perfected products, both in machines and records, as are turned out to-day by our manufacturers.



Arthur Friedheim, Pianist, Listening to One of His Own Records.

Newton Jones, of Oshawa, Ont., Can. Although located in a small city off the beaten tracks of large city industry, Mr. Jones has nevertheless achieved a reputation for energy and business acumen that would be a credit to a dealer in the larger cities in the United States.

own records as played on a Grafonola in Mr. Jones' store, and although Mr. Friedheim made but a few hours' stay in Oshawa, Mr. Jones was successful in securing this photograph which he is using to excellent advantage in his publicity work.

TO REGULATE HYPOTHECATION

Of Outstanding Accounts the Subject of a Bill to Be Submitted in the New York Legislature—Credit Men's Association of New York Behind the Measure to Prevent the Secret Transfer of a Debtor's Accounts.

There will soon be another meeting of the legislative committee of the New York Credit Men's Association to discuss further the draft of the proposed model bill drawn by Julius Henry Cohen, at the instance of the National Association of Credit Men, to regulate the hypothecation of outstanding accounts by preventing the secret transfer of all or substantially all of a debtor's accounts, as previously outlined. Following a lengthy discussion on the various phases of the contemplated measure by the members of the committee and others it was decided to allow the members of the committee and others directly concerned further time to consider the matter before taking decisive action. The bill is also to be considered by the legislative committees of the five affiliated associations in New York State. The legislative committee took occasion to disapprove of the Greenberg bills, recently introduced into the Legislature.

Secretary-Treasurer J. Harry Tregoe, of the National Association of Credit Men, commenting on a letter written by a Baltimore concern to the effect that the proposed model bill was the result of the opposition of commercial bankers to the business of discount companies, said his denial of this statement could not be made too emphatic. He said the matter had come up over a year ago, through frauds perpetrated in Chicago and Milwaukee, and from a realization that no legitimate

business house could keep going if it entered into a deal to pay two per cent. a month for money. The point was made at the meeting by one of the speakers that ninety-nine per cent. of the commis-

Record Service

IS WHAT YOU NOW NEED

Dealing with BUEHN assures you the best in service that can be had. Stocks of EDISON CYLINDER and VICTOR DISC RECORDS, both Domestic and Foreign, as complete as large orders and factory deliveries can make them.

Be convinced and send your order for RECORDS to



Louis Buehn
Philadelphia



"Tone plus tone-control" comes as near as ever you will get to a nutshell definition of what the Columbia is offering and what Columbia customers are wanting.



(Write for "Music Money," a book "full of meat" for those dealers interested in quick and frequent turnover of capital.)

Columbia Graphophone Company
Woolworth Building, New York

LECTURER ATTACKS "CANNED MUSIC"

Percival Chubb's Lecture Provides Player-Piano and Talking Machine Dealers with Arguments Showing the Widespread Influence of Those Instruments—Dealers Discuss Lecture.

(Special to The Talking Machine World.)

St. Louis, Mo., March 9.—Percival Chubb, formerly of New York and now lecturer of the Ethical Society here, has run counter to the teachings of the talking machine dealers and player-piano enthusiasts. In a recent Sunday morning lecture on "The Menace of Low-Class Amusements and the New Hope Inspired by the Coming St. Louis Pageant," he denounced player-pianos, talking machines and moving pictures. The pageant, it might be explained, is planned as a gigantic out-of-doors show that will demand the services of 5,000 actors and will illustrate scenes in St. Louis history.

But to get back to talking machines. Mr. Chubb introduced this part of his lecture with the statement that the craftsman of a century ago was much happier than the workingman of to-day who learns to make one part of a shoe, and when he loses his job cannot again work unless he finds a job running the same sort of a machine. He said:

"He no longer sings at his work, as did old Hans Sachs, the cobbler poet of Nuremberg. He knows nothing of St. Crispin, his patron saint, and no longer celebrates the saint's day with his fellow journeymen in dance and song and ceremonial. His domestic life is narrowed to a small dimension. He is an absentee father. Compared with that of the old-time shoemaker, his culture is almost nil. His amusements are those of patronage and not of participation—bought and not self-provided; as a consequence it shows a steady tendency toward the machine-made type.

"The phonograph gives music, but it spells death to the home arts of song and instrumentation, to the family amateur performances, solos, choruses and instrumental music. The moving picture play banishes the living presence, the speaking personality, from the stage. The arts of the theater will be banished by the mute machinery of the movies. During the past week there was only one dignified play in St. Louis, the fourth city of the United States. This obtains in the first hundred cities of the United States."

Some of the talking machine enthusiasts said, "Oh, piffle!" Others who took themselves and their machines more seriously wrote to Mr. Chubb to express their opinion of a man who saw things in this light, also to tell him some of the things that the talking machine had done as an educator and stimulator of public taste.

OPENS STORE IN GLOVERSVILLE, N. Y.

The Darling & Denton Co., who handles the Victor talking machine line in Gloversville, N. Y., held a formal opening of its new quarters in the Darling Block recently. The demonstrating rooms for Victor records occupy a section of the second floor, while Victrolas are on display on the third floor with pianos and players.

NEW CONCERN IN KANSAS CITY.

Phonograph Co. of Kansas City, Organized to Job and Retail Edison Disc and Cylinder Lines in Middle and Southwest—Salesrooms Handsomely Fitted Up—Demonstration Booths of Concrete—Has Wide Territory.

(Special to The Talking Machine World.)

KANSAS CITY, Mo., March 11.—The Phonograph Co., of Kansas City, has been formed here, and will job both the Edison disc and cylinder lines in the Southwest, as well as conduct a retail establishment at 1012 Grand avenue. The company will be managed by W. P. Hope, who has traveled for the Edison Co. for ten years past. The identity of other officers of the company will not be announced at present.

The jobbing territory of the Phonograph Co., of Kansas City, will comprise western Missouri, Kansas, Oklahoma, Arkansas, and west to Colorado. In this territory a limited number of dealers will be placed, though care will be exercised to keep the field from being overcrowded and overworked, in order that retailers of the Edison may be given a fair opportunity.

The spacious storeroom at 1012 Grand avenue, which will serve both as retail and wholesale quarters of the new company, is being renovated throughout, and when completed will be the most attractive establishment of the kind west of Chicago. A concert hall will be a feature of the first floor, which will be the retail department. A small stage will be installed, and the public invited to drop in at any time to rest and hear a few of their favorite selections. Desks for the public also will be provided.

The demonstration rooms will be as nearly soundproof as human ingenuity has been able to attain. Each room will be of concrete, and will be equipped with double glass windows and doors. The fixtures throughout the establishment will be particularly handsome, and will be constructed to order.

The basement, which is light and airy, will serve as the wholesale department. The basement floor is on a level with an alley in the rear; this fact facilitating shipping operations. Wholesaling already has begun, two earloads of Edison machines being on hand. The retail establishment will be ready for occupancy about April 1.

The establishment of the Edison house here adds a good deal of interest to the talking machine situation. The Columbia Co. has a branch here, while the Victor is well represented by the J. W. Jenkins' Sons Music Co. and other piano houses with talking machine departments. The Schmelzer Arms Co., which has jobbed the Edison cylinder, will continue to handle that line, the formation of the Phonograph Co. of Kansas City having no effect on the Schmelzer affiliations.

The Udell Works, manufacturers of cabinets, Indianapolis, Ind., paid signal honor to a life of devoted labor and loyalty to the firm when it closed down the plant Monday afternoon, March 2, that all the employes might attend the funeral of Wesley Kinder, sixty-five years old, who died suddenly.

CHANGES IN TWIN CITY TRADE.

W. J. Dyer & Bro. Take Over Talker Department of Kohler & Hinrichs—St. Paul Department Store Installs Talking Machines—Opera Season Helps Columbia Record Sales—Edison Discs in Demand—News of Month.

(Special to The Talking Machine World.)

MINNEAPOLIS AND ST. PAUL, March 9.—The extensive talking machine department of Kohler & Hinrichs has been taken over by W. J. Dyer & Bro. Kohler & Hinrichs were pioneer distributors of Victor goods in the Northwest until their business was taken over by their creditors. In the reorganization the talking machine department was eliminated. The addition of this stock, of course, is another feather in the cap of the old house of W. J. Dyer & Bro.

Following the example of two Minneapolis competitors, one of the big department stores in St. Paul is planning to install a talking machine department. As a matter of fact, deals already are closed, but the house is not ready to make a public announcement. Both Victor and Columbia machines will be handled. It is understood that the Minneapolis and Powers stores in Minneapolis are doing very nicely with their experiment with talking machines and phonographs.

The Columbia Grafonolas continue to increase in popularity in the Twin Cities and the Northwest, the \$100 Mignonette being a tremendous seller both in Minneapolis and St. Paul. Over in St. Paul, Manager C. P. Herdman is stocking up for the grand opera season.

It happens that many of the principals are Columbia artists, notable among them being Mary Garden, Maggie Teyte, Margaret Keyes, Henri Scott and Hector Dufranne. With such an array of artists in the city for more than a week, it will be strange if the record sales do not increase.

Archie Mathies, of the Talking Machine Co., is carrying on his educational recitals with both Victor and Edison machines in expectation of a successful opera season in April. Trade with this house has been uniformly good even during the dull period of February, and it is confidently expected that the coming year will show much greater results than did 1913.

"We have one big complaint" declared Laurence Lucker, head of the Minnesota Phonograph Co., "and that is that we can't get goods fast enough. Since concentrating our talking machine department solely on the Edison instruments our business has been conducted on more satisfactory lines, and everything would be fine if we only could get the goods. We are away behind with our regular customers and are holding back ten applications for country agencies, as we are not sure that we can provide them with stocks."

TO ERECT MONUMENT TO EDISON.

A movement was launched at Sandusky last week to collect funds for the building of a monument to Thomas A. Edison, the memorial to be constructed at Milan, O., his birthplace. It is planned to dedicate the monument on Mr. Edison's seventieth birthday.

The Most Attractive Stock Record System on the Market

It is Practical—An Attractive Fixture—And Made in any Finish

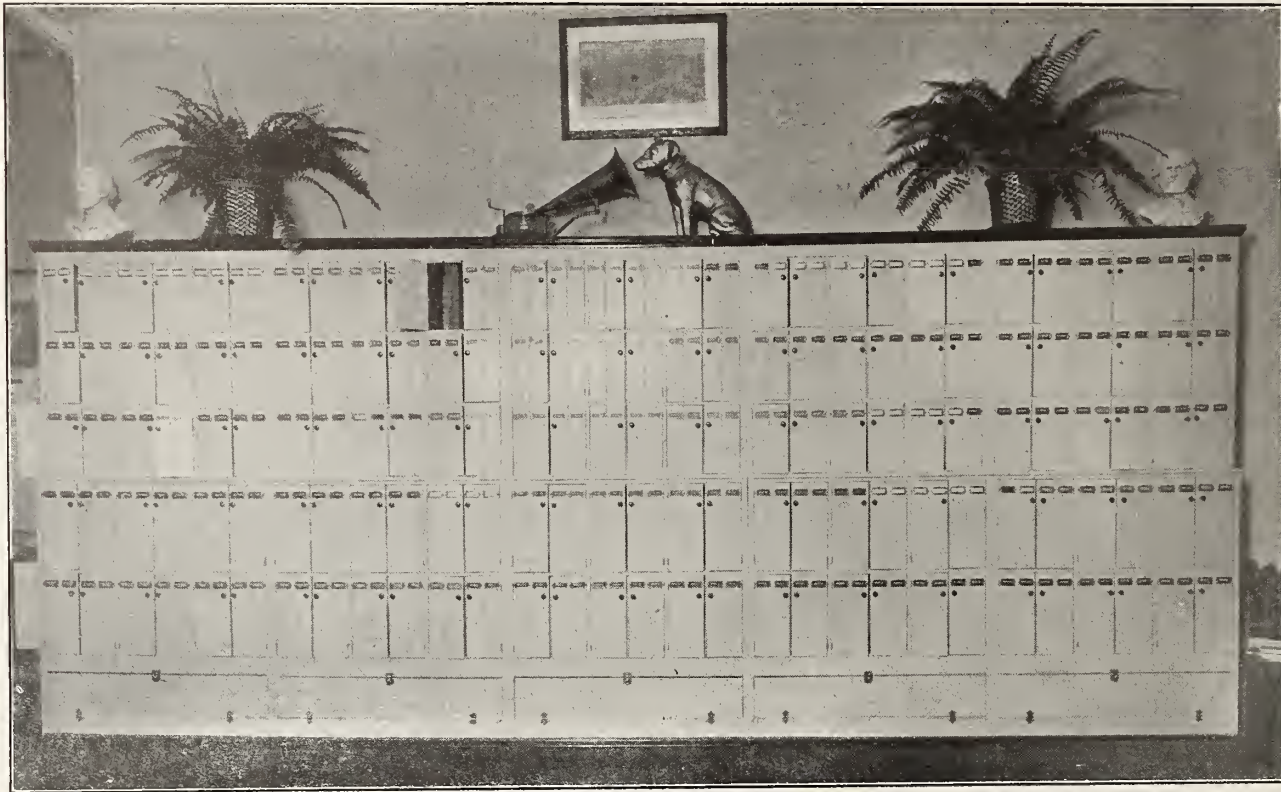

This photograph shows 5 sections

A ragged looking record stock unnecessary. Record envelopes will soil—but they need not be visible. MOST COMPACT RECORD RACK EVER DEvised. Each Section accommodates 1,000 records—size 6' 4" high, 14" deep at the base, and only 36" wide. 5,000 RECORDS IN THE 15 RUNNING FEET shown in cut. PRICE \$27.50 per section—F.O.B. New York.

DELIVERY BAGS

STOP BUYING WRAPPING PAPER AND TWINE. We have SOLD MILLIONS of these delivery bags. Each bag has a popular record list on it.

Record buyers MUST READ this list—either in taking records home or unpacking the parcel.

Our Dealers who are using these wrapping envelopes endorse them most highly, and give us reports of LARGE CASH SALES made of records selected from just ONE of these envelopes. PRICE \$11.00 per thousand, including imprint of Dealer's name.

STOCK SYSTEM

The record stock system, which has been installed by 90% of our larger Dealers, is something that would pay you to investigate. It is a system which makes you buy JUST WHAT YOU NEED—and in making you know your record stock better, gives you a GREATER SELLING CAPACITY.

Write us for the system that will DECREASE YOUR INVESTMENT IN SLOW SELLING RECORDS—and PUT THAT MONEY IN YOUR CASH DRAWER.

VICTOR DANCE RECORDS
Turkey Trots, Tangos, One-Steps, Bostons

Victor Military Band	17276	10	\$0.75
Victor Military Band	17277	10	\$0.75
Victor Military Band	17278	10	\$0.75
Victor Military Band	17279	10	\$0.75
Victor Military Band	17280	10	\$0.75
Victor Military Band	17281	10	\$0.75
Victor Military Band	17282	10	\$0.75
Victor Military Band	17283	10	\$0.75
Victor Military Band	17284	10	\$0.75
Victor Military Band	17285	10	\$0.75
Victor Military Band	17286	10	\$0.75
Victor Military Band	17287	10	\$0.75
Victor Military Band	17288	10	\$0.75
Victor Military Band	17289	10	\$0.75
Victor Military Band	17290	10	\$0.75
Victor Military Band	17291	10	\$0.75
Victor Military Band	17292	10	\$0.75
Victor Military Band	17293	10	\$0.75
Victor Military Band	17294	10	\$0.75
Victor Military Band	17295	10	\$0.75
Victor Military Band	17296	10	\$0.75
Victor Military Band	17297	10	\$0.75
Victor Military Band	17298	10	\$0.75
Victor Military Band	17299	10	\$0.75
Victor Military Band	17300	10	\$0.75

No. 1005
NEW YORK TALKING MACHINE COMPANY
"HOME OF THE VICTOR"
Foreign Records of every nation—Catalogues mailed upon request.
81 Chambers Street, and 63 Reade Street, New York City
Tel. 1916 Worth.

NEW YORK TALKING MACHINE COMPANY

81 Chambers Street, New York City

MORE COMPLETE STOCKS AVAILABLE IN PHILADELPHIA

Jobbers and Dealers in Better Position to Handle Large Business—New Agents for Edison Disc Phonographs Plan Active Campaigns for That Line—To Try for Fixed Interest on Instalment Sales—Pennsylvania Talking Machine Co. Plans Improvements.

(Special to The Talking Machine World.)

PHILADELPHIA, PA., March 10.—The Philadelphia talking machine business during the month of February was most satisfying, and in every case the dealers report a considerable increase over last year, some of them having almost doubled their business of a year ago in spite of the very bad weather that prevailed during the end of the month.

About the only change in the situation during the month was the taking on, by several of our most substantial firms, of the Edison disc phonograph. Ramsdell & Son were the first of the piano houses to install the instrument, and while they have built no booths for its display, they have rearranged their warerooms in such a way that they can handle a full line of the Edison as well as a complete library. Already they report a most satisfactory sale of these instruments.

The Cunningham Piano Co. has entered into the business on a large scale. It has given over a considerable space on one side of its first floor wareroom, and has built several very attractive booths, and is advertising the Edison in many different ways, notably with an attractive electric sign in its window. The Cunningham Co. never does anything in a half way, and it will give the Edison a representation which will be bound to bring it trade. It has placed Mrs. M. L. May in charge. Mrs. May was formerly in charge of the Edison store on South Twelfth street, and is an enthusiastic Edisonite, and well capable of looking after the Cunningham department.

These are the only two firms who thus far have gotten in a stock of Edisons, but there will be a number of others to follow. N. Stetson & Co. will handle the Edison, but they have not yet made the necessary preparations. Strawbridge & Clothier will handle it if they will be able to get the required space. As it is they are very much crowded for room, for they now have a complete stock of Victor and Columbia machines as well as records made by both companies.

Strawbridge & Clothier will make a number of changes in their department. They have at present four large hearing rooms, entirely too large for requirements, and they will partition each room and make eight separate rooms, and then they will build a room at the rear of their grand organ, which will be used exclusively as a record room, and they will remove all of their records from their present position.

H. A. Weymann & Sons report that they have been receiving shipments from the Victor in good quantities the past week, which has enabled them to fill a good portion of the orders that have been placed on schedule. They report that their Victor business in February was more than double that of the corresponding month of last year, which is considered remarkable when taking into consideration the scarcity of the supply. When placing their advance order with the Victor Co. for March records and also the special dance records, they anticipated re-orders from their dealers and ordered their stock accordingly, which enabled them, much to the satisfaction of their dealers, to fill all their repeat orders in full and make shipment the day the orders were received.

"There is no question in my mind," says Harry Weymann, referring to the effort to get the dealers to charge a six per cent. on deferred payments, "but that we will be able to bring about the project. It is not likely that we will be able to get the dealers to agree as a body to charge this percentage, but each individual will agree to this proposition and thus evade any complications at Washington. There is no doubt that the small dealers will soon follow suit when the larger dealers take the initiative. An effort will also be made to have the dealers refrain from educating the public, in their advertisements, to know that talking machines can be purchased for \$10 down and \$10 a

month. Of course, where there should be exceptional cases where this was done, it would not hurt us all as it does to-day, for there are lots of people who would come in and pay cash if the customer knew that it was the rule to charge six per cent. interest on deferred payments."

The Pennsylvania Talking Machine Co. has had an exceptional February business. It has shown a hundred per cent. increase over last year, and the attractive record list of the past three months has in a great measure been responsible. The firm has been contemplating elaborate changes in its warerooms, but has not been able to put these into effect for the reason that it did not want to disturb business, and thought it best to wait to the end of the opera season and the close of the Metropolitan box office. It will build a gallery on the first floor, with a seating capacity for several hundred persons, where concerts will be given daily. It will be able to do this on account of the extreme height of its ceiling and yet not interfere with the convenience of its regular warerooms. Manager Eckhardt has gone West on a business trip of a week's duration.

Louis Buehn reports that he has had a most satisfactory month in February, and ran about ten per cent. ahead of last year in spite of the continued shortage of machines and records. He has been doing especially well with the Edison dictating machines and has placed a number of additional machines with the Pennsylvania Railroad, the Link Belt Co., the Biddle Hardware Co., and other prominent concerns.

COLUMBIA WITH ATHERTON-BYRD CO.

The Columbia Co. closed a very important deal this week when arrangements were consummated with the Atherton-Byrd Co., of Haverhill, Mass., whereby this prominent and successful furniture house will handle a complete line of Columbia machines and records. This same company handles the Columbia products in Worcester, Mass., and Lewiston, Me., and its success has been so emphatic that it has enlarged both departments since it was first opened a short while since. The Atherton-Byrd Co., caters to a high-class furniture clientele, who evidently appreciate the merits of the Columbia machines and records.

A NEW DEMONSTRATION IDEA.

Machines Placed in Rest Room of Famous-Barr Co. Serve to Attract Numerous Prospects for Department—Capable Salesmen, with Mind Reading Ability, Placed in Charge.

(Special to The Talking Machine World.)

St. LOUIS, Mo., March 9.—Manager Ligon, of the Famous-Barr Co., is getting some advertising from a novel plan of entertaining the visitors in the great department store's rest room. Perhaps 2,000 persons a day pass through this rest room and most of them stop to rest, to wait for some one or merely to loiter. Recently a player-piano and an Edison disc and Victrola have been placed there with one of the floor salesmen of the piano department in general charge.

A steady concert is given with the piano and talking machines alternating. If Messrs. Bollman and Harcourt, who usually are in charge of the demonstration, see any persons taking more than ordinary interest in the music they do a mind reading stunt and put on the selection that they think will strike home best. For instance, if the man is wearing a G. A. R. badge, they put on "Marching Through Georgia." If the veteran shows gray in his clothing, it is "Dixie." The women's walk often shows whether they are guilty of tangoing or merely walking up the aisle in church. Anyway a guess is ventured, and no one is the wiser if it misses, but if a hit is made the person often walks over to talk about it. The instant the person asks what make machine or player or what tune it is, there begins a lock step toward the elevator and on the sixth floor where all of the musical instruments are sold. The other salesman is keeping a weather eye out and he takes the next elevator to the rest room to stand guard. The possible customer who inquired for details is given opportunity to look over the stock of talking machines, player-pianos, records, rolls or whatever may have struck his or her fancy, and a good many times money changes hands before time is called. As a business getter, this informal stunt produces better results than the formal concert.

RETURNS FROM EUROPE.

Edward N. Burns, vice-president of the Columbia Graphophone Co. and manager of the export department, is due back in New York March 15 on the steamer "Imperator" after a five weeks' trip to Europe. E. E. Robinson, the well-known traveler for the Columbia export department will arrive in New York next Tuesday after an eight months' stay in the Orient, where he closed an excellent business and established many new agencies.

Ask Us What We Mean

Accuracy Correctness Despatch

VERSUS

Overworked Efficiency

Have built our wholesale Victor Talking Machine

BUSINESS



No time lost if you order of us. Our Record Stock Exceedingly Complete. Our Machine Stock Exceptionally Large.

Silas E. Pearsall Company

FACTORY PRODUCTS

18 West 46th Street NEW YORK

Ask Us What We Mean

MUCH INTEREST IN EDISON DISC JOBBERS' ASSOCIATION.

Jobbers Throughout the Country Quick to Realize the Importance and Desirability of the New Organization and to Apply for Membership—Association Headed by Men of Recognized Standing in the Industry and in a Position to Accomplish Much Good.

The formation in New York last month of the Edison Disc Jobbers' Association, as was announced in the February World, has aroused great interest on the part of Edison disc jobbers and dealers throughout the country as mark-



H. H. Blish, President.

ing a distinct forward step in the presentation of the new Edison product to the trade and to the public.

Organized by a group of jobbers recognized as representative of the most substantial and best element of the trade, the new association has impressed the trade with its importance, with the result that those Edison disc jobbers who were unable for one reason or another to attend the sessions in New York last month have been quick to advise the officers of the organization of their



F. H. Silliman, Treasurer.

interest and desire to become affiliated with the body.

The result of concerted effort on the part of the Edison disc jobbers throughout the country in presenting the new disc proposition to the dealers and to the public is evidenced in the wonderful success that has attended the campaign up to this point, both in the matter of signing up dealers of standing and also in reaching the retail buyers. In all this the jobbers and the factory have worked together, following the meeting of the Edison disc interests held in New York last fall, and the value of a permanent organization for the discussion and development of campaigns and for taking up any other matters of interest and im-

portance to the trade at large is to be appreciated.

As announced in The World last month, the association is headed by H. H. Blish, one of the prime movers in its organization, and whose company, Harger & Blish, of Des Moines, Ia., has for years been a recognized factor in phonograph circles throughout Iowa and a large section of the Middle West. F. H. Silliman, of the Pardee-Ellenberger Co., New Haven, Conn., and Boston, Mass., has for years been one of the most active figures in the trade throughout New England, and H. G. Stanton, the secretary, is with the R. S. Williams & Sons Co., Ltd., Toronto, Ont., one of if not the most prominent concerns in talking machine and phonograph fields in Canada. C. B. Haynes, head of C. B. Haynes & Co., Richmond, Va., and the vice-president of the association, is one of the pioneers in the trade in Virginia and the Carolinas and enjoys an enviable position in that field. In addition to the four officers named, the executive committee includes Laurence H. Lucker, of the Minnesota Phonograph Co., Minneapolis.



H. G. Stanton, Secretary.

Minn.; C. E. Goodwin, of the Phonograph Co., Chicago, and B. W. Smith, of the Phonograph Co., Cincinnati, O., all men of recognized standing in the industry.

The Edison disc jobbers have at the head of their association men with ideas who have proven their ability to accomplish the results desired. The future of the organization will be watched with interest.

FROM WINTER TO SUMMER.

Several Members of Local Talking Machine Trade Escape Some of New York's Winter Weather by Sojourning in Bermuda.

J. H. Dodin, in charge of the talking machine department of Gimbel Bros., under Manager George W. Morgan, who has been spending several weeks at Hamilton, Bermuda, accompanied by Mrs. Dodin and a party of friends, returned to "Old New York City" just in time to "enjoy" the worst storm of the winter. There was quite a little convention of talking machine men in Bermuda about the middle of February, the "conventioners" being E. Paul Hamilton, manager of the piano and talking machine departments of Loeser & Co., Brooklyn, N. Y., with Mrs. Hamilton, Sol. Lazarus, the well-known dealer of New York, and Thomas Green, the popular Victor Co. salesman, accompanied by Mrs. Green.

In all your dealings, remember that to-day is your opportunity; to-morrow some other fellow's.

IMPORTANT ALBUM IMPROVEMENTS.

George Bates, of the New York Album and Card Co., Inc., Tells of the Improvements Recently Made in Company's Specialties.

"After extended experimentation and tests we have decided to equip our talking machine record albums with leather-covered ring pulls in the future, instead of metal ones," said George Bates, of the New York Album and Card Co., Inc., 23 Lispenard street, New York. "In addition to being considerably more attractive than the metal pulls, these leather-covered ring pulls eliminate any possibility of scratching the talking machine cabinet or furniture, as happens so frequently when the metal pull is used. This new ring pull is finished to match the album perfectly in color, making it most attractive and doing away with the glare of the metal pull, which has been the cause of considerable annoyance to talking machine owners. The elimination of all chances of scratching the highest polished cabinet or piece of furniture is in itself an advantage that will doubtless be recognized by the dealers throughout the country."

The New York Album and Card Co., Inc., which was incorporated last month, takes the place of the New York Post Card Album Manufacturing Co., continuing the business at the same address with the same officers and organization.

NEW YORK'S EDISON JOBBING CENTER

Will Be Located at 473 Fifth Avenue—Will Not Be Ready for Occupancy Until Late in the Summer—Lease Signed This Week.

A ten years' lease of the property 473 Fifth avenue, between Fortieth and Forty-first streets, New York, was signed this week. When the building is reconstructed it will constitute the Edison jobbing headquarters in New York City. The lease was signed by Babson Bros., of Chicago, but it is said that the new jobbing center in New York will not be operated under this name. Full details of this new Edison move, which is of interest to New York talking machine men, will appear next month. The building will not be ready for occupancy until late in the summer.

NEW COLUMBIA "JEWEL."

The Columbia Co. will make the first public announcement of its new "Jewel" machine through the medium of a striking advertisement in the March 21 issue of the Saturday Evening Post. In addition to featuring this popular \$35 machine, this advertisement will offer a special \$50 combination, including the "Jewel" twenty records, two record albums and 1,000 needles. In a letter to its trade the Columbia Co. suggested the advisability of placing orders for "Jewels" immediately.

A VISITOR FROM MIDDLETOWN.

One of the many visitors last week to the offices of the Columbia Graphophone Co. was President Holmes, of the Holmes Music Co., Middletown, N. Y., an enthusiastic Columbia representative. Mr. Holmes placed a substantial order for Columbia products, as he contemplates enlarging his Columbia department in the very near future to accommodate a fast-growing business.

OPTIMISTIC OVER CONDITIONS.

John Dorian, the popular treasurer of the Columbia Co., returned Tuesday from one of his frequent trips through the South and West. A keen student of industrial conditions, Mr. Dorian's optimism regarding his recent trip is a certain indication of good times with the Columbia dealers.

The Morse clarifier, made by Morse Bros., of Minneapolis, Minn., is an attachment for talking machines that consists of a number of small graduated pipes, so calculated in length as to bring vibrations to a hearer's ear up to the point where resonance occurs. It is built in several models so that it can be attached to all talking machines, where its function is to clarify sound reproduction.

Many a man mudds himself trying to splash his competitor.

CLEVER WINDOW DISPLAY

Made by the Columbia Graphophone Co. Branch in Cleveland, of Which G. R. Madson is Manager—Its Originality of Arrangement Wins Praise of Prominent Business Men—Great Business Getter for the Featured Records.

(Special to The Talking Machine World.)

CLEVELAND, O., March 7.—The accompanying photograph will give a fair idea of the originality and beauty of the latest window display presented



Columbia Co.'s Very Striking and Individual Window Display.

at the local store of the Columbia Graphophone Co., 913 Euclid avenue. George R. Madson, manager of this store, has been congratulated by many prominent business men on the exceptional characteristics of the display, and J. McClelland, of the local sales staff, who designed the window, has been the recipient of general praise and commendation from local members of the trade.

The window consists of a flooring of moss, with gravel walks, and contains the following arrangement of dolls and kewpies illustrating various records. Beginning at the left, there is a doll dressed in a gingham gown, with the label, "The Girl in

FLOODS HURT COAST TRADE

Particularly the Southern Section Where Great Losses Occurred—Talking Machine Dealers Report Increasing Interest in This Line at All Points—An Interesting Budget of News from Southern California Territory.

(Special to The Talking Machine World.)

LOS ANGELES, CAL., March 7.—The unusually heavy rains, which were so destructive and did such a tremendous lot of damage, caused a slump in all business affairs, including the sale of talking machines and records. Old settlers claimed it was the worst storm of its kind in Los Angeles. All of the surrounding towns were completely isolated for several days, causing a general tie-up of the railroads and electric lines. Many people lost their homes and property throughout the Arroyo Seco section.

Barker Bros.' Furniture Co. has just moved its talking machine department into the main store building, and has equipped it in the most up-to-date fashion. Several soundproof rooms for demonstration purposes have been lavishly furnished and fitted with very attractive displays of Columbia and Edison goods.

Chas. S. Ruggles, local manager of Sherman, Clay & Co., is around after being laid up with a sprained ankle.

W. L. Davenport, of Chihuahua, Mexico, recently arrived in Los Angeles from Hermosillo, where he has had a very flourishing talking ma-

chine business, but has been compelled to give it up and get out, as the present conditions in Mexico were too hot for him.

the Gingham Gown"; directly in back of this doll is a toy express train containing three kewpies, with the name of "Honeymoon express." Then follows dolls dressed and arranged to illustrate the following records: "What Do You Mean, You Lost Your Dog?" "You're a Great Big Blue-Eyed Baby," "Peg o' My Heart," "Oh, You Million Dollar Doll," "Where Did You Get That Girl?" "Kiss Me Good Night," "On the Old Front Porch," "Get Out and Get Under," "Sit Down, You're Rocking the Boat," "When Silas Did the Turkey Trot to Turkey in the Straw."

The window has been in use for the past two weeks, and Mr. Madson states that it has been an absolute business-getter, the particular records mentioned having met with a remarkable sale. The cost of the window was exceptionally low, \$1.10 being the entire expense for this beautiful display. William Taylor, Sons & Co., Columbia dealers in this city, furnished and dressed the dolls and were very glad to do so, as the window has been an excellent advertisement for them in connection with their doll and kewpie department. The dolls are designed in a clever fashion, bearing apt reference to the songs they represent.

chine business, but has been compelled to give it up and get out, as the present conditions in Mexico were too hot for him.

Baxter & Northrop have recently made a change in their talking machine department by appointing E. L. Dornseiff manager of the department. Miss Annie M. Pennick, who was formerly connected with the Portland, Ore., branch of the Columbia Graphophone Co., is now one of the sales force.

The Southern California Music Co. reports through its manager, O. A. Lovejoy, a very good wholesale and retail trade. A very unique and attractive window display from February 9 to 16 marked the celebrating of the sixty-seventh birthday of Thomas A. Edison. In one window was displayed the Edison disc machine, the Edison cylinder machine and the Edison home kinoscope. The other window showed the equipment of a modern office using the Edison dictating machine. Another feature was the giving away of several thousand buttons with just the figures "67," indicating the sixty-seventh birthday of Mr. Edison. An attractive demonstration of the same goods was given at the Los Angeles Business Show the week following.

W. F. Stidham, manager of the Columbia Graphophone Co.'s local branch, reports a very active February business, the results being a material increase over the business of the same month of last year. The demand leans very strongly to the higher priced instruments.

G. Stewart Pooler, connected with the selling

force in the talking machine department of the Geo. J. Birkel Co., has been shipping over some of the best deals of the season in the Victor line.

The Edison Coast representative, A. V. Chandler, spent a few days in Los Angeles, then leaving for the Imperial Valley and Arizona. Throughout his travels Mr. Chandler has found the Edison disc machine to be very popular.

E. C. Polk, from Sidney, Australia, visiting Los Angeles for a short time, is much interested in the Edison disc line, which he would be much pleased to gain the privilege as a dealer in his section.

Newton I. Hancock, traveling representative for the Columbia Graphophone Co., of this city, returned from a trip through all Southern California and Arizona, reporting a very satisfactory condition of the talking machine trade.

INTRODUCE AUTOMATIC STOP.

Standard Gramophone Appliance Co. Exhibits New Stop at Industrial Show in Brooklyn—Described in Detail by Manager Thomas Kirkman—Simplicity a Strong Feature.

The Standard Gramophone Appliance Co., 173 Lafayette street, New York, manufacturers of the Standard fibre needle cutter, which has scored a most gratifying success in the short while it has been on the market, placed on the market last month a new automatic stop, which is designated the Standard. This new stop was exhibited for the first time at the Loeser & Co. booth at the Brooklyn Pure Food and Industrial Exposition, which took place the first two weeks of this month, and attracted considerable attention and praise.

In introducing this new stop, Thomas W. Kirkman, manager of the Standard Gramophone Appliance Co., remarked: "One of the most important features of our new stop is its extreme simplicity, which is indicated by the fact that it weighs but one and one-half ounces. This stop does not mar the appearance of the machine in the least, as its mechanism is so arranged that all the screws are invisible and leave no marks on the machine itself. We have tested this stop thoroughly before placing it on the market, and can now assure the trade that the new Standard automatic stop will positively perform all that is claimed for it."

The new Standard stop is manufactured in two styles, nickel-plated and gold-plated, the former is marketed to retail at \$2, and the latter at \$3, with the usual discounts to the trade.

A CANADIAN CORPORATION.

The National Talking Machine Co., Ltd., Winnipeg, Man., has incorporated as wholesale, retail and jobbing dealers in talking machines and accessories, with capital stock of \$50,000. Incorporators: Aylmer Everett Dilts, Alexander B. Alexander, David Wilson, Herbert E. Soal and Albert C. Ferguson.

WANTED

Job lots of any make talking machines and records.

Will buy for cash second-hand machines, shop-worn records and supplies. Correspondence strictly confidential. Give full particulars and lowest price. Address "Cash Buyer," Talking Machine World, 220 So. State Street, Chicago.

EXPERIENCED RECORDER WANTED

Wanted, a high-class, experienced recorder. State experience and salary. Address Martin Connor, 156 West Washington St., Chicago, Ill.

RECORD MAKER WANTED

Wanted, a high-class, experienced record maker. State experience and salary. Address Martin Connor, 156 West Washington St., Chicago, Ill.

INTEREST ON INSTALMENT SALES

Formed the Subject of Discussion at a Meeting of the Managers of the Leading Talking Machine Houses in Chicago—Sense of Meeting That Six Per Cent. Interest Rate Should Be Charged on All Deferred Payments.

(Special to The Talking Machine World.)

CHICAGO, ILL., March 12.—Pursuant to a call by L. C. Wiswell, a meeting of talking machine managers in the loop district was held at Kuntz-Remmler's this afternoon to consider various matters affecting the retail trade. The principal subject of discussion was the matter of interest on instalment sales. It developed that some concerns have been charging interest invariably while others have waived it providing the entire amount was paid up in a specified number of months or if in the monthly payments a stipulated minimum amount was maintained.

It was the general sense of the meeting that all such exceptions were against the best interests of the trade, and that in the future a 6 per cent. interest rate should be charged on all deferred payments. It is believed that all of the concerns in the loop will take the same view. In fact, since the meeting several of the absent managers have been communicated with and have so expressed themselves. Those present were: L. C. Wiswell, Lyon & Healy; F. A. Siemon, Wurlitzer Co.; Ed. Smith, Kimball Co.; George Davidson, Talking Machine Shop; G. H. Bent, George P. Bent Co.; P. T. Stark, P. A. Stark Piano Co.; Leonard Hall, John A. Bryant Piano Co.; E. A. Fearn, Tresch, Fearn & Co., and George C. Vining. Other matters were suggested, but lack of time prevented adequate discussion. Another meeting will be called in the near future at which the matters of terms of instalment sales and allowances on second-hand machines will be considered. The formation of a permanent association was not broached at the meeting, but it is not improbable that such an organization may result.

This movement has nothing whatever to do with the old Chicago Talking Machine Dealers Association composed entirely of dealers outside the loop district.

THE GRAFONOLA CO., INC.

Organized in Cleveland—Takes Over Columbia Store at 913 Euclid Avenue, Cleveland, and Will Feature Columbia Goods Exclusively.

(Special to The Talking Machine World.)

CLEVELAND, O., March 10.—The present Columbia store, at 913 Euclid avenue, has been purchased by the Grafonola Co., Inc. C. A. Routh, who was assistant manager of the Columbia, is at the head of the new company, and will handle Columbia goods exclusively.

Hereafter, the Columbia Co. will confine itself to the wholesale and distributing business exclusively. The new store is on the fourth floor of the new mammoth Kinney & Levan Building.

The H. M. Brainard Piano Co. will open at 1317-19 Euclid avenue on April 1, with a complete line of Columbia goods.

JOHN McCORMACK WAS GUEST

Of the Southern California Talking Machine Men's Association at Banquet at Union League Club on Way East from Australia—Given a Great Welcome—Evening Was One of Keen Enjoyment to All Present.

(Special to The Talking Machine World.)

LOS ANGELES, CAL., March 7.—The Southern California Talking Machine Men's Association gave a banquet at the Union League Club on the evening of February 13 in honor of Mr. and Mrs. John McCormack, the great Irish tenor, who is just making his tour through the entire country. Aside from Mr. and Mrs. McCormack there were present Chas. F. Wagner, manager; Donald Macbeath, violinist, and Vincent O'Brian, pianist; L. E. Behymer, impresario, and his private secretary, Miss Rena McDonald.

After the sumptuous repast short talks were



John McCormack.

given by E. P. Tucker, manager of the Wiley B. Allen Co.; C. H. Rundel, secretary of the Southern California Music Co., and Impresario L. E. Behymer. Mr. McCormack gave a very interesting talk pertaining to the value of educating the people to a higher standard of music, stating that Irish music was not all jigs and reels, but real folk lore of Ireland. Mr. McCormack says this was the first time he was ever entertained by any talking machine association of this kind.

So impressive and congenial were the characters of this great artist and his little wife that it made a strong impression upon the members, their wives and friends of the association, that they unanimously elected Mr. and Mrs. McCormack to honorary membership.

Through the courtesy of Mr. Behymer all members of the association that were present at the banquet were given tickets to the McCormack

concert, which was immensely enjoyed by all who attended.

This Talking Machine Men's Association, under the official direction of Sibley G. Pease, president; B. H. Burke, vice-president; H. H. Fish, secretary and treasurer, and Lorenz Dornseiff, assistant secretary, has proven to be a great help in the talking machine trade. It is a little over three years old, with a membership of nearly a hundred, composed of both employers and employes. General questions pertaining to the welfare and condition of the trade are always under discussion and advisement, which has proven to be a great civic center for the talking machine trade.

APPOINT NEW EDISON AGENTS.

Four Connecticut Houses Take on the Edison Disc Line—J. W. Scott's Effective Work.

Reference is made elsewhere in this issue to the success scored by J. W. Scott, special representative of the phonograph sales department of Thomas A. Edison, Inc., in New Haven, Conn., where he has interested thousands of people in the new Edison disc phonograph. His recitals have attracted a great deal of interest and have been the subject of considerable mention in the New Haven papers.

During his stay in New Haven Mr. Scott closed a number of new agencies for the Edison line, among others the Calder Music Shop, one of the best equipped establishments in New Haven, which will give the Edison line a strong representation; the Alfred Fox Piano Co., which has stores in Stamford and Bridgeport, and C. L. Pierce & Co., of New Britain. These establishments placed large initial orders for Edison disc phonographs and records.

Mr. Scott is quite a veteran in the phonograph field, having been associated with the Edison interests for over fifteen years.

MASTERPHONE POPULARITY.

Demand for Fibre Needle Masterphone as Well as Original Steel Model Is Enormous—Prominent Dealers Are Placing Large Orders.

"The demand for the Masterphone is steadily increasing, both in the original steel model and the fibre needle styles," said an official of the Masterphone Corporation, 187 Broadway, New York. Although the fibre needle Masterphone has been on the market but a short time, we have been unable to supply the demand for it, and at the present time are behind on our orders. From all parts of the country we are in receipt of letters from prominent talking machine dealers, speaking in the highest terms of the improvement that is noticeable by the use of the Masterphone on all classes of records.

"The steel needle Masterphone is now being marketed by dealers in practically every fair-sized town in the country, and the consistent advertising that we have been placing in the national mediums has been of considerable benefit to our patrons in producing inquiries that resulted in ready sales."

Schafford Record Albums

17 new style cut envelopes, bound in either brown silk cloth or imitation leather in any color. Strongest bound Album made. Schafford Albums are of the highest quality and should not be confused with lower-priced, inferior albums.

Send for sample and prices. The quality will surprise you.

SCHAFFORD ALBUM CO., 27-29 Walker St., NEW YORK CITY

RELATIONS OF DEALER AND JOBBER AND VICE-VERSA.

W. E. Kipp, President of the Kipp-Link Phonograph Co., Indianapolis, Discusses "What Should a Dealer Expect of a Jobber; and What Should a Jobber Expect of a Dealer" in Current Issue of Phonograph Monthly—His Views Are Interesting to the Trade.

When asked to write on this subject, I knew it was one that could be made to cover many pages. It is not only a very broad subject, but one that carries with it an endless number of changeable conditions; and it must be remembered also that opinions along these lines vary quite a great deal.

I will therefore attempt to give my views on the subject in the fewest possible words.

First, I think that the dealer expects, and has every right to expect, that his jobber should carry a stock of goods at all times which is sufficiently large to meet his trade requirements. The jobber should remember that he is after all the dealer's real friend and support in the business and the one on whom he depends always for complete information regarding the line, as well as to furnish the goods promptly. The jobber should therefore always be prepared and willing to give the dealer every service possible.

He should pay particular attention to the small details which so often the dealer needs help on. He cannot be too careful to be prepared at all times to furnish all of the smaller repair parts as well as the larger and more staple items on a moment's notice; also, be always fully equipped with printed matter. The little items are the ones that the dealer often needs just as badly as a large order.

To do all these things the jobber is sometimes entirely at the mercy of the manufacturers and is helpless to give good service, because of his inability to secure a stock equal to the dealer's demands. However, it still remains true that sometimes the jobber has failed to anticipate properly what will be expected of him, and in this way he causes his dealers an annoyance that should be avoided. I do not believe there are very many Edison jobbers operating these days who are guilty of mistakes of this kind, as they have all known for a long time what a powerful and attractive line the Edison goods have developed into, and for this reason they are not only willing, but are constantly endeavoring to carry more liberal and complete stocks.

The dealer in my opinion has a right to expect good, honest advice from his jobber at all times as to what he should order and carry in stock. The jobber cannot always be depended on in this, but he is usually fairly able to know where one dealer's opportunities to handle certain items in the line are far better than those of another dealer. I think, therefore, that the jobber should always be as frank and conservative with his dealers as possible, and guide them toward carrying an attractive and complete stock, but no larger than is necessary in his locality. In this way he helps keep the dealer from becoming overloaded with unsalable goods. (Overloading a dealer always creates a feeling of uncertainty and should be avoided.)

The jobber, I think, should always be willing to go out of his way to help his dealers overcoming certain troubles which the dealer seems to be unable to cope with. He can do this because of his thorough knowledge of the business. The jobber should bear in mind that he is devoting practically all of his attention and effort to this one line of goods, while a great number of the dealers only carry Edison goods in addition to many other lines. For this reason it cannot be reasonably expected that the average dealer is as well posted as a jobber. It is perfectly true that when any important changes take place in the line that the factory immediately sends complete bulletins describing such changes to all of the trade. The jobber usually absorbs this information and makes it an important part of his business, while the dealer very often looks the bulletins over, takes it for granted that it is of no great importance, and soon loses sight of the information it contained. Right here is one of the important features of the jobbing business, and where the jobber should always be prepared to give information to the dealer that happens to need it.

There are many dealers who are unable to carry a complete stock of all the different types of machines, but who might have good prospects of selling some of the finer styles if they could show their customers the article itself. It is impossible for the jobber to send these fine machines out to the dealer on approval, and I believe, therefore, that every dealer should be made to feel thoroughly at home to send such prospective buyers directly to the jobber, and I think that the jobber should use every possible effort to help that dealer land the sale. In other words, the dealer should be made to feel that the jobber's display room is also his, and that every service will be rendered his customers should he send them to the jobber.

Having been in the jobbing business for a number of years myself, I have had the opportunity to make many personal calls on most all of my dealers, and I have heard many complaints from some that were, indeed, well founded; then again I have heard many that were not.

A dealer should remember that the jobber is not a performer of miracles, but just an ordinary human being like most any other fellow; that he has an endless amount of trouble to take care of just the same as every one else. The dealer should remember that the jobber is always trying to do the very best he can to deserve that dealer's business. It should be remembered that he is simply a middle man in the phonograph proposition; one who buys and pays outright for the goods he has to sell.

The dealer should always keep in mind that the jobber's risks are terrific, and that he very often has every dollar he owns at stake; in most instances Edison jobbers have absolutely nothing else to depend upon for a livelihood.

The dealer should remember also that the jobber's profits are very limited. It can easily be seen, therefore, that the jobber needs every dollar's worth of business that he can get.

I think that when a jobber is doing all he can to please a dealer and is giving him good service that it is absolutely wrong for that dealer to transfer his business elsewhere. Of course, if the jobber is unable to give satisfactory service or should be neglectful, the dealer is perfectly entitled to seek elsewhere for the goods.

Another demand that the dealer should not make

on his jobber, and which is always an imposition, is to ask the jobber to send goods on approval. This is unfair to the jobber because his greatest endeavor at all times is to keep his stock clean and fresh looking and in its original factory packing. Further than this, the jobber may receive demands most any time for the very goods that might go out on approval, and then lose opportunities to make bona fide sales on these goods; all of which robs him of profits that he is justly entitled to.

The greatest handicap that the dealer can possibly work on the jobber, after all, is to neglect paying his bills promptly. The dealer should remember that the jobber is buying from a company who insists on prompt settlements, and strictly according to their contracts. As his profits are very small and his expenses very heavy, it is wrong to abuse the jobber by holding him up in favor of some other creditor. Simply because the jobber has trusted the dealer with a liberal line of credit should make that dealer many times more anxious to send in returns promptly and so prove his appreciation.

As I said at first, this subject is one that could be made to cover many pages, and I realize there are many points at issue that I have not covered; but to sum up the whole matter, I would say, the dealer has a right to expect every attention, help and courtesy that the jobber can possibly give; that he in return should be as fair and liberal-minded with the jobber as he possibly can.

I believe that to-day a better understanding along these lines exists between the two than ever before, and I hope it may be improved as we go along.

READING THE CHECKERBOARD.

The story is told of a certain merchant who had dined and wined to the limit found his way home in the wee sma' hours. He reached the library just as he heard his wife's footsteps at the head of the stairs leading to her bedroom. He hastily reached for a book from the library shelves, dropped into a big easy chair and had the book spread across his lap, when his wife entered. "Will! what are you doing here at this hour?" she asked. "Just reading, dear. This book has been in the library five years. I've made up my mind dozens of times to read it. To-night I'm going to finish it. Don't worry, my dear. You can go to bed. I'll continue reading." "Will," replied the wife with authority, "close up that checkerboard and come to bed."

The Simpson-Crawford store, New York, with its talking machine adjunct was closed March 14.

UNION SOUND BOX

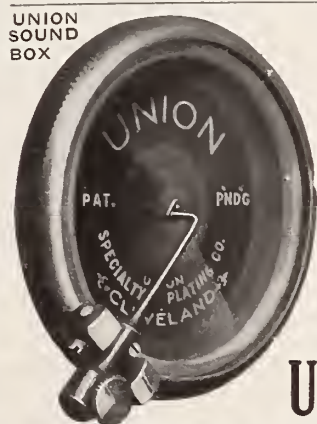

Gold plated, Nickel or Oxidized \$20 per dozen net

3 THAT SELL ON FIRST SIGHT

At the left is the new UNION Sound Box just out, taking Fibre or any make of needle. It is the latest improvement in sound reproduction, and fits all Disc Machines.

UNION TALKING MACHINE SPECIALTIES

The upper right-hand illustration shows the UNION Modifier, a quick selling device, giving Edison, Victor and Columbia owners absolute control over the volume of sound. The lower illustration shows UNION No. 1 for playing Columbia and Victor records on Edison Machines. UNION No. 1 contains the UNION Modifier feature.

Write to-day for descriptive folders and prices on these three easy selling specialties.

All persons selling goods infringing our patents are liable to suit for such infringement.

THE UNION SPECIALTY & PLATING CO.

409 Prospect Ave., Cleveland, Ohio

UNION No. 1 Gold Plated, Nickel or Oxidized, \$10 per dozen net



UNION MODIFIER

Gold, Nickel or Oxidized \$5 per dozen net

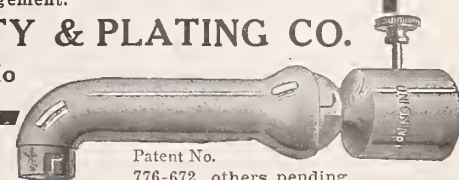

Patent No. 776-672, others pending.

When a customer wants a "Jewel" is a mighty hard customer

The announcement of the Columbia Grafonola "Jewel," \$35, was the most significant trade move since the announcement of the Columbia Grafonola "Favorite."

The "Jewel" has the hinged enclosing lid. It has the exclusively tone control leaves at the front which have supplanted the old idea of small doors. It has the new Number 6 Columbia reproducer. It has the regular standard Columbia motor—double spring drive. *And it is all of \$15 better than the market price of instruments of other manufacture.*

And the "Regent": to begin with, there's nothing else on the market that even looks like it.

In figuring up the reasons for the great Columbia advance during 1913, it becomes powerfully evident that the Columbia Grafonola "Regent" tables had a lot to do with it. Every dealer in the country who shut his doors against the \$100, \$150, \$200, and \$225 "Regent" models lost money on the deal. Shut his *own* daylight out. Lost his *own* money.

But there's a big field open and we have only just begun to plow. Show us how we can put the stronger, and you will still be inside the mark.

And all the way between we have a magnificent line of product—instruments and records both. But the product to be sold is no more important to the man who sells it than the selling policy behind it and the demand in front of it.



Columbia Graphop

Woolworth Building

” or a “Regent” Grafonola he
 r to sell something else

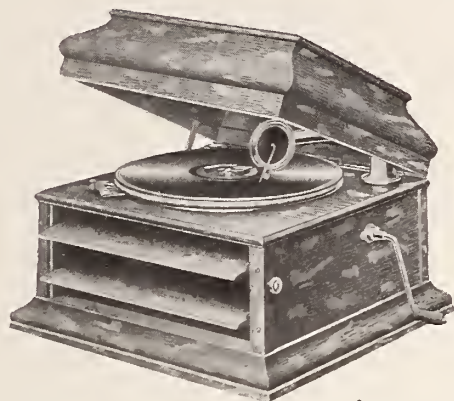

The Columbia “Jewel” Grafonola
 —A genuine Columbia Grafonola,
 completely enclosed, equipped with
 a lid, complete with all the details
 of the modern disc Grafonola equip-
 ment, for \$35.



One of the famous Grafonola tables—the Columbia “Regent”
 Grafonola—with tilting record trays—\$225. Other
 “Regent” tables at \$100, \$150 and \$200.

ophone Company

g, New York



HANDLING COLLECTIONS OF INSTALMENT ACCOUNTS.

Some Important Suggestions on This Vital Department of Business Presented by Benj. Switky, the Well-Known Talking Machine Distributer, Who Has Given Much Serious Thought to Topics of This Nature—Views Presented Below Are of Much Value.

We are living in what might be called the "Instalment Age." To-day, about the only thing that cannot be had on credit is a ride on a street railway. In former years a store that sold on the instalment plan was in a class known as instalment houses; and families that cared for their reputation in the neighborhood were careful not to have goods delivered by a wagon bearing the name of a well-known instalment firm.

How things have changed! The tendency toward instalment buying is growing stronger each year. The best and biggest of stores are now urging their customers to avail themselves of the "club plan" in buying furniture, musical instruments, hats, caps, shoes, clothing, jewelry—in fact, everything. Of course, we must concede that the better stores for a time were reluctant to indorse or adopt such methods of merchandising, and drifted into easy-payment selling only as a result of keen competition.

While deploring the inroads made upon good, profitable cash business by the tempting instalment inducements held out, the object of this discussion is to deal with collections. Still, one cannot discuss collections without pointing out that *difficulty in collecting is the direct result of reckless extension of credit*. Reckless extension of credit includes selling on long time even to people who can be classed as good risks.

Most stores seem too anxious to write up a \$200 or \$300 contract just because it makes a good showing on the day's sheets. On the other hand, in the effort to surround themselves with the comforts and the pleasures of life, many individuals and families forget to ask themselves whether they can really afford these things which they are buying. How many of them, when they are about to sign a contract for a piano, or a Victrola, or a fine parlor suit, ever stop to realize that they are placing a mortgage upon their humble earnings—and that the mortgage is to run for a period of one, two or three years? How many persons can confidently claim that they will meet their payments regularly and honorably during one, two or three years without interference from unexpected misfortune such as sickness, unemployment or other unforeseen causes?

Although the work of collecting does not begin until after the deposit is taken and the goods delivered, nevertheless it is part of the work of collecting to have at hand certain data that will help to throw light on the account. For this purpose I would suggest that every dealer provide himself with a quantity of "application blanks"—a regular printed form, which can be made up very cheaply. (Specimen application blank follows.)

APPLICATION BLANK.

(No Contract executed with a minor.)

Name in full.....
 Residence..... How long?.....
 Former residence..... How long?.....
 Business address..... How long?.....
 Married or single.....
 Goods desired.....
 Terms.....
 References:.....
 Remarks:.....

The application blank, after being carefully filled in, should be pinned to the signed contract. In many cases, when an account becomes uncollectable after a year or two, particularly if the party has removed, you can trace him through friends who knew him at the old address, or through business associates, etc. If your customer is married and has children, you can locate their new whereabouts by inquiring of their playmates, or get the information at the public school which issued the transfer to another school.

Furthermore, in the course of verifying the facts and references given you will get a pretty good idea of the character and veracity of the applicant.

At the time of signing the contract you should impress on your customer the fact that the instalments are payable *at your store*. Tell him that you have no regular collector, first of all because of the expense, and secondly, because you wish to protect him against the inquisitiveness of his neighbors, who might gossip about the collector's visits. Impress upon him, however, that you will be after him should he allow his payments to lag.

Keeping Track of Payments.

Besides your regular method of bookkeeping you must have a system by which the names of customers will be brought automatically to your attention on the day when the payment falls due. For this purpose I would suggest that you or your bookkeeper have on the desk a little calendar pad. You can obtain one from your stationer for about fifteen cents. The pad is mounted on a metal stand and fastened by a screw. There is a separate leaf for each day of the year. Each leaf has on it the day and date, with a blank space above for memoranda.

Every time that a new account is posted in the ledger, the name should also be entered on the pad as follows: Say the sale was made on Monday, January 5, and payments are to be weekly. Write the customer's name on the leaves of the pad bearing the dates of Tuesday, January 13, 20, 27, and February 3, 10, 17 and 24. After that the entries on the pad need appear only twice a month, say about the tenth and twentieth. In this way you keep close watch on the accounts for the first two months. They cannot be overlooked. When a payment is past due a statement should be sent. When two payments are due together the customer should have his attention called to the fact. Ordinarily, it is not necessary to send statements to weekly accounts, except as a reminder.

Accounts payable monthly should likewise be entered on the pad, unless the payment falls due on or about the first of the month. The presumption is that all accounts in the ledger are reviewed monthly on the first, at which time statements are mailed.

Method of Collection.

As previously stated, it should not be necessary to incur any expense other than stationery and postage in collecting the bulk of the accounts. I find too many dealers neglecting their stores in order to call on accounts ninety per cent. of which could be handled from the office. Others, again, employ irresponsible collectors, placing themselves at the mercy of poor devils whom they cannot afford to pay liberally because it eats too deeply into the margin of profit.

Many a time I have heard the remark, "It's no use, you've got to go after it." True. The man who does not look after collections aggressively has no right to do instalment business, for he cannot get good results. On the other hand, a man cannot devote most of his time and energy to collecting alone. He must find time to look after the selling. I have known dealers to go out collecting while leaving a boy or girl of about fourteen or fifteen years in charge of the store. These may serve as monitors, but they cannot sell.

The time for you or your clerk to call on the delinquent payer is after Uncle Sam has failed to bring you results. Nor do I favor unnecessary letter writing. When a monthly payment falls due, or a weekly payment is past due, send a statement. The name of the weekly payer should be entered on your memorandum pad so that your attention will be called three or four days later. The monthly payer should be allowed a week or ten days, and entered on the pad accordingly. (Some dealers use a card system, advancing the card from one space to another; but often the cards are accidentally misplaced and confusion results.)

If the remittance has not arrived within the time allowed, mail another statement showing the amount of payments due. On the statement write: "Second request. Please remit." Allow from three to five days. If even then you have received no remittance, mail another statement, on which you write: "*Final request*. Unless remittance is received by return mail we shall be obliged to take action." This third statement should be sent by registered mail. Mark your envelope so that the postoffice will send you a card showing the signature of the addressee.

Fifty per cent. of the delinquents yield to the "second request" statement. Of those cases requiring registered "final request" statements I have found that positively nine out of ten respond with a remittance. The receipt of a registered letter, also the fact that they are required to sign the return card, impresses them with the seriousness of the whole matter. You will find some of them waiting for you when you open the store the following morning.

So far it has cost you either two, four or sixteen cents to obtain the remittance. In the last case it is still cheaper than spending time and carefare.

Handling collections by mail I have found to be better in many cases than through collectors. Personal contact with the debtor makes it hard for the collector to deal sternly with some cases, and gives an unscrupulous customer a chance to jolly or impose on him.

While I do not advocate harshness or heartlessness in handling instalment collections, nevertheless, in view of many experiences, I think it well that you emulate the proverbial landlord in the matter of exacting prompt payment. It is no uncommon occurrence for a collector to make fifteen calls and find only five "at home."

Once we lost track of a customer. Statements were returned by the postoffice marked "removed—address unknown." After diligent search we located her. She had changed addresses twice in the interval and now lived on the outskirts of Brooklyn. Of course she was glad to see us. She claimed to have worried greatly because we did not call, although she overlooked notifying us of change in address. She admitted that her husband was working as a motorman, but she could not pay anything that day (Friday). However, she very generously explained that if we would call every Thursday afternoon between one and three o'clock, when her husband came with his pay, she would give a dollar regularly every week hereafter. To quote the lady herself:

"Me Moike, he gits paid ivry Thorsdy; an' thim as calls on Thorsdy afternoon between one and three o'clock gits ther money."

As it was impossible to make a special trip every Thursday, I suggested to the lady that I would send her a quantity of self-addressed stamped envelopes with her name written on the back, and requested that she put a dollar in an envelope every week and have Mike mail it between one and three p. m. Thursday. I also instructed her to wait for a receipt for each dollar before sending the next one.

It is a good idea to inclose a self-addressed stamped envelope for the next payment when mailing receipts. This will often facilitate prompt remittance.

Just a final word about professional pullers and collection agencies. Most of them are either crooked or incompetent, and some of them are both.

NEW SOUND BOX POPULAR.

A specialty that is being sold with success to the trade is the "Balance" sound box, for use on the new Edison disc phonographs when it is desired to play other makes of disc records. It is manufactured by A. F. Meisselbaeh & Bro., Newark, N. J., who invested considerable time and money before they evolved a sound box that would come up to the requirements of the conditions under which it would be used. W. H. Meyer, of this concern, spoke of the remarkable success achieved since the introduction of the "Balance" sound box, adding that the demand is growing.

LIVELY TRADE IN BALTIMORE.

February Business Proves Excellent and March Starts Off with a Rush—F. A. Dennison Elected Member of Rotary Club—New Columbia Dealers—What the Various Prominent Houses Report Anent Business.

(Special to The Talking Machine World.)

BALTIMORE, Md., March 9.—“If the remainder of the present month keeps up the way that the first four working days of the present month have shown forth from a sales standpoint, you can just put it down that we will go on record as having done the biggest amount of business that we have ever done in any one month, and the largest amount that we ever will.” This seems like a rather broad statement to make, but nevertheless it is vouched for by F. A. Dannison, manager of the local branch of the Columbia Graphophone Co. Mr. Dennison said that February showed up in remarkably fine shape, and that business has started in during March with one of the biggest rushes that he has ever known.

That business in all lines of the trade was in excellent shape during February would seem to be further verified by the statement of William C. Roberts, manager of the local store of E. F. Droop & Sons Co., Victor and Edison dealers, that he has been compelled to augment his forces in order to properly handle the increased trade. Mr. Roberts made a trip during the week to the Victor factory to see what he could do in the way of hurrying along a number of orders that have not yet been filled.

Manager Dennison of the Columbia Co. was elected a member of the Rotary Club the past month.

Joseph Fink, proprietor of the Fink Talking Machine Co., reports a good February and states that the way March has started in he has good reasons to expect good results during the present month.

The A to Z Business Bureau has just opened up a place and has taken on a full line of Columbia goods.

Both the Columbia and Victor had a good run during the month at the Sanders & Stayman Co., Inc., according to the report of Manager Albert Bowden of that department.

SWITKY SUFFERS BY EXPLOSION.

Window of Store of Benj. Switky Blown in by Explosion of Gas in Street and Some Victrolas Damaged — Machines and Records Saved from Flood in Basement by Quick Work.

A great quantity of illuminating gas under the street near the junction of Twenty-third street and Fifth avenue, New York, on Sunday morning caused an explosion which broke several large water mains and badly damaged several neighboring buildings and stores, among them that of Benj. Switky, the prominent Victor distributor, at 9 West Twenty-third street. One of the large plate glass windows of the Switky store was blown in, the glass splintering a part of the case of a small Victrola and scratching the case of a larger instrument. The basement of the building was also flooded to the depth of several feet, but through the efforts of the staff of the Fifth Avenue Building, in which the store is located, a number of cases containing machines and records were moved to a higher level before the water reached them and thus saved from damage. Mr. Switky, who hurried to the store, upon learning of the damage, estimated his entire loss at less than \$100, and the business of the store was not interfered with.

That every cloud has a silver lining is proven by the fact that a motion picture concern took pictures of the damaged district, and the Switky store with the Victor dog prominently displayed on the remaining window will be flashed on screens in picture theaters throughout the city. Some advertising.

OUR FOREIGN CUSTOMERS.

Amount and Value of Talking Machines Shipped Abroad from the Port of New York for the Past Four Weeks.

(Special to The Talking Machine World.)

WASHINGTON, D. C., March 10.—Manufacturers and dealers in talking machines will doubtless be interested in the figures showing the exports of talking machines for the past four weeks from the port of New York:

FEBRUARY 14.

Antofogasta, 3 pkgs., \$165; Callao, 3 pkgs., \$286; Cardiff, 2 pkgs., \$115; Havana, 27 pkgs., \$736; Havre, 14 pkgs., \$420; La Guayra, 10 pkgs., \$473; 5 pkgs., \$145; Libau, 70 pkgs., \$1,408; Liverpool, 20 pkgs., \$583; London, 33 pkgs., \$1,151; Manila, 7 pkgs., \$566; Newcastle, 4 pkgs., \$111; Puerto Barrios, 6 pkgs., \$381; Valparaiso, 4 pkgs., \$95; 5 pkgs., \$328.

FEBRUARY 21.

Barranquilla, 44 pkgs., \$1,237; Buenos Ayres, 3 pkgs., \$498; Glasgow, 5 pkgs., \$124; Guayaquil, 10 pkgs., \$140; Hamburg, 1 pkg., \$100; Havre, 4 pkgs., \$165; La Guayra, 14 pkgs., \$1,132; La Plata, 3 pkgs., \$198; London, 3 pkgs., \$12; 140 pkgs., \$5,066; St. Petersburg, 13 pkgs., \$251; Vera Cruz, 11 pkgs., \$398; Vienna, 24 pkgs., \$625.

FEBRUARY 28.

Amsterdam, 7 pkgs., \$561; Antofogasta, 8 pkgs., \$154; Barranquilla, 9 pkgs., \$231; Belfast, 3 pkgs., \$539; Buenos Ayres, 145 pkgs., \$18,172; Copenhagen, 40 pkgs., \$1,250; Geneva, 6 pkgs., \$205; Gibara, 9 pkgs., \$354; Hamburg, 31 pkgs., \$2,899; Havana, 18 pkgs., \$1,319; 22 pkgs., \$574; Havre, 2 pkgs., \$234; Leeds, 4 pkgs., \$164; Liverpool, 14 pkgs., \$432; 13 pkgs., \$858; Milan, 5 pkgs., \$616; Montevideo, 18 pkgs., \$638; Santa Marta, 2 pkgs., \$129; Rio de Janeiro, 18 pkgs., \$1,360; Shanghai, 1 pkg., \$144; Sydney, 40 pkgs., \$4,261; Vera Cruz, 32 pkgs., \$827; Vienna, 2 pkgs., \$155.

MARCH 7.

Bilboa, 3 pkgs., \$135; Bolivia, 7 pkgs., \$398; Callao, 5 pkgs., \$208; Haval, 2 pkgs., \$101; Havana, 30 pkgs., \$1,300; 15 pkgs., \$734; Kingston, 7 pkgs., \$182; Liverpool, 17 pkgs., \$667; 18 pkgs., \$585; Maracaibo, 5 pkgs., \$413; Manchester, 7 pkgs., \$226; Melbourne, 2 pkgs., \$144; Newcastle, 9 pkgs., \$277; Pernambuco, 7 pkgs., \$379; Puerto Barrios, 5 pkgs., \$787; Vera Cruz, 40 pkgs., \$1,984.

D. L. Hogan has leased rooms at 147 South Schuyler avenue, Kankakee, Ill., and will open a talking machine store.

Here Is A Chance For You

Mr. Talking Machine Dealer, if you are wide-awake you are looking for a way to **increase your business!**

Most progressive business men are so inclined, and right here is a **point** for you.

You can handle pianos very nicely in conjunction with your present line, but the main thing is to get the **right** piano.

Now, we have built up one of the **largest** piano manufacturing enterprises in the world within a brief period of time, and we have done it by the delivery of **values**—the largest kind of **values** to our customers.

We can deliver the same kind of **values** to you, and we can help you to show **bigger profits** at the end of the year.

The year is young yet, but do not let it get old before you take up this **profit** making plan with us.

We can supply you with pianos and player-pianos which will fit in **admirably** with your line.

H. P. NELSON COMPANY

Makers of Grands, Uprights and Player-Pianos

North Kedzie, North Sawyer, West Chicago Aves. and C., M. and St. Paul R. R., CHICAGO.

Simplest and Most Accurate.

Net weight only 1½ oz.

Standard Automatic Stop

Nickel . . . \$2.00

Gold . . . 3.00

Send 25 cents stamps for free sample

Order through your jobber.

Liberal Discounts.

Standard Gramophone Appliance Co.

173 Lafayette St., New York

ABSOLUTELY NEW Everlasting Dustless Record Cleaner

PATENT APPLIED FOR



FRONT VIEW

The Everlasting Dustless Record Cleaner is made of the finest grade of carefully selected wool skin with the wool cut short.

It polishes, cleans and prolongs the life of records. Makes them look like new. It positively cannot scratch or mar records in any way, and can be cleaned with benzine, gasoline or cleaner preparation.

Retails for 15 cents. Write us to-day.

Sold to dealers in dozen lots only.

\$1.25 per dozen



BACK VIEW

Lyon & Healy

FIBRE NEEDLE CUTTER

OVER
50,000
SATISFIED
USERS



EXACT SIZE

You can order through your Jobber. He will supply you; if not, send your order to us.

The wonderful success of the Lyon & Healy Fibre Needle Cutter in the last two and a half years is due to the following facts about the cutter:

The Blades of the Lyon & Healy Fibre Needle Cutter are made of the finest grade of properly tempered tool steel. The upper blade is pivoted above and back of the cutting edge of the lower blade. It is held in place by a very high tensioned spring to insure correct leverage and a perfect point at every cutting.

The cutter is fitted with a guide that prevents the cutting away of too much of the needle, and also has a receptacle that receives all the waste. It is very simple and easy to operate, and with ordinary usage should last indefinitely without sharpening.

This cutter is invaluable to all users of the Fibre needle, as a needle may be used twelve to fifteen times where one of the cutters is in use.

Now is the time to get your order in and share in the profits.

Retail Price **\$1.50**

SEND US
YOUR
ORDER
TODAY

Lyon & Healy

CHICAGO

Largest Victor Distributors

LIBERAL
DISCOUNT
TO THE
TRADE

FROM OUR CHICAGO HEADQUARTERS

CONSUMERS' BUILDING, 220 South State Street, E. P. VAN HARLINGEN, MANAGER.

(Special to The Talking Machine World.)

CHICAGO, ILL., March 10.—Trade in talking machine circles is fine—it's great—especially in the record line, if the trade could only get all the records it wanted. Machines are fairly plentiful and factories have very few complaints on this score. The shortage in the record supply is due to a great extent to the dance craze which seems to grow rather than to diminish. The call for this class of records, in addition to the regular increase in record business which comes at this time of year, has caused factories to work full capacity and yet leaves a great percentage of unfilled orders—a percentage far in excess of last year's shortage. This, in spite of the fact that factory capacities have been greatly increased. Dealers are promised relief within a very short time, but, inasmuch as most of them heard this story some weeks back, there are some who are inclined to be pessimistic.

Harry Lauder Poses.

L. C. Wiswell, manager of the talking machine department at Lyon & Healy's, has on his desk, photographs of Harry Lauder, the great Scotch comedian, in two very new and attractive poses. The photographs were taken in Mr. Lauder's apartment in his recent visit to Chicago, and appeared to be the best likenesses of the "world's highest salaried entertainer" that have ever been taken

There is also a new photograph on Mr. Wiswell's desk of Pietro Diero, whose Victor records, accordion and concertina, have met with such a demand during the last few months of the dance craze.

L. K. Cameron Improves.

L. Keene Cameron, formerly retail manager of the Victor department of the Rudolph Wurlitzer Co., has written a letter to assistant manager, Fred A. Siemon, in which he says he is enjoying the climate of the Southwest immensely and that his health is much improved.

Henry Saak Wants More Stock.

Henry Saak, well-known Columbia talking machine dealer of Milwaukee, was in the city recently making arrangements with the Columbia Co. for the installation of a very liberal stock in his new store, 1602 Vliet street. Mr. Saak reports that he has built four large demonstration booths that give every opportunity for the proper demonstration of machines and records. Mr. Saak has extended the glass show windows of his store front so that they are conspicuous to the people on the street for a long distance.

Good Columbia Business.

C. F. Baer, manager of the Chicago office of the Columbia Graphophone Co., reports very satisfactory increase over the first three months of last year.

"There has been a tremendous demand for records," said Mr. Baer, "and our catalog of dance numbers has been drawn on very heavily. We anticipated these conditions and very fortunately were able to fill 90 per cent. of our record orders.

Prominent among the more popular records is our number 55531 which consists of 'Y Come La Va,' a tango, and 'Puppschen,' a one-step, played by Prince's band. As an illustration of the popularity of the record, I want to say that one dealer, in sending in his order, asked for five times as many of this number as for any other.

"The immense amount of advertising that we have been doing lately is making itself felt with irresistible force, and created such a demand that our stock of records and one style of our machines were nearly exhausted. This condition, however, was remedied at once."

Talking Machine Co. Notes.

A new and handsome edition of the booklet entitled, "Our 500 Best Sellers," has been prepared by Salesmanager Roy Keith of the Talking Machine Co., and is just being issued to the company's dealers. These booklets have been used to good advantage for some time past by dealers all over the West who use them in circularizing their patrons. The records listed in the booklet are the result of long experience in supplying records and are particularly interesting in view of the fact of the present great record shortage. Another interesting help, issued by the Talking Machine Co., is in the form of a pad listing ten popular favorites which is designed to be placed around the dealer's store where it can be secured easily by the record buyer and the sheets used to jot down the number of records, and, at the same time, offer a number of good suggestions that are often quickly acted upon.

E. L. Barker is a new addition to the traveling sales force of the Talking Machine Co., and left on his initial trip March 9. Mr. Barker has been assigned to Indiana and Michigan, formerly covered by Geo. P. Cheatle. Mr. Cheatle will continue to call on a number of the dealers in those two States and will also do some additional work the nature of which has not yet been decided upon.

Another addition to the company's force is in

the person of H. E. Whitman, formerly of Elmira, N. Y., who last week took up his duties as floor salesman.

To Enlarge Kimball Space.

The talking machine department of the W. W. Kimball Co. has enjoyed a remarkable business since its recent organization under Mr. Cullen's direction, and plans are now under way that will probably involve the removal of the entire department from the second floor to the third floor where a greatly increased space is possible.

Big Crowd Witnesses Dancing.

Kenneth Holman, manager of the newly organized La Grange Talking Machine Co., of La Grange,

The Chicago Office of The Talking Machine World has removed to new and larger quarters at 1024 Consumers' Building, 220 So. State Street.

Ill., last Tuesday and Wednesday nights gave the citizens of his town an opportunity to witness the dancing of Mr. Kucker and Martha Courtney, the young people who have been drawing crowds to the Talking Machine Shops. The program was arranged in much the same way as at the Shops with the tango, hesitation, maxixe and Brazilian demonstrated with the aid of the Victrola. La Grange came in a body, and crowded the shop so thoroughly, that show windows were endangered, and an officer had to be called to see that no damage was done.

Iowa Dealer Optimistic.

A. C. Moore, manager of the Edison and Victor departments of the Pelletier Co., Sioux City, Ia., was a visiting dealer of last week. Mr. Moore looks to a big year in 1914, and cites as one evidence of the prosperity that has visited that section of Iowa, the fact that at the recent Auto Show, held in that city, almost a million dollars worth of machines were sold.

Shops Dancing Continues.

The Talking Machine Shops continues to draw new customers to its attractive quarters through the medium of the dances described in last month's World, and probably will entirely through March. Mr. Kucker is now seen with a new

(Continued on page 34.)

The Practical Fibre Needle Cutter—THE WADE

The WADE embodies the right principle, worked out through long experience. It is simple, durable and accurate. It trims the needle at an angle resulting in the best tone.

The WADE cutters are made of the best steel and are absolutely guaranteed.

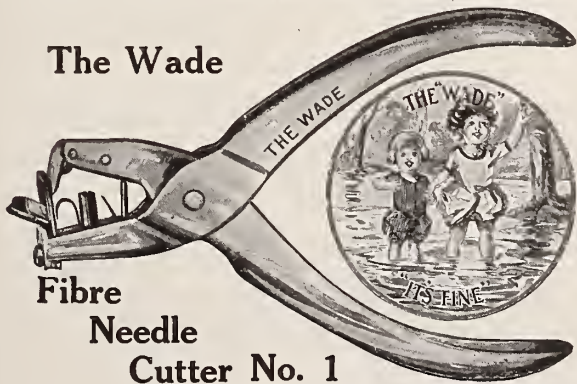

The Wade

Fibre Needle Cutter No. 1

The WADE is the most economical cutter. It has a self-acting stop, which prevents waste and enables one to get from 12 to 15 perfect playing points.

No. 1 is a very popular cutter which has given excellent service. No. 2 has a double action, making it especially easy to operate and affording the most powerful cut of any tool made.

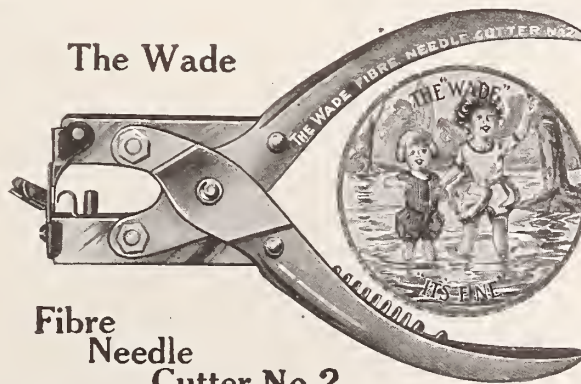

The Wade

Fibre Needle Cutter No. 2

RETAIL PRICES—No. 1, \$1.50; No. 2, \$2.00

Order from your regular Distributor—we sell to Jobbers only

WADE & WADE,

3807 Lake Ave. PHONE, DOUGLAS 8108 CHICAGO, ILL.

FROM OUR CHICAGO HEADQUARTERS—(Continued from page 33).

partner, Martha Courtney, and they have introduced a number of new steps that have elicited much applause. Business has been greatly increased since the introduction of the idea and its advertising value has been tremendous.

"Business has been very good," said Geo. W. Davidson, "with February far in excess of the same month last year. If we could obtain records we would set a record that would last for some time. Among the dance records are 'Leg o' Mutton' and 'Some Smoke'; 'Isle d'Amour' and 'San Souci.' Vessella's band records are also selling well. They are the sextette from 'Lucia', 'Jewels of the Madonna' selection and Liszt Hungarian Rhapsody."

R. V. Hahn, formerly with the Knight-Campbell Co., of Denver, is a new addition to the sales force of the Shops.

Personals and Visitors.

J. D. Moore, manager of the talking machine department of the Lion Dry Goods Co., Toledo, O.; L. C. Parker, of Gimbel Bros., Milwaukee, and Mr. Abbott, of the Boston Store, Milwaukee, were three department store heads visiting Chicago recently.

Other visiting dealers included: M. B. Manor, Manor Bros., Hebron, Ill.; C. S. Sinclair, Dundee, Ill.; Mr. Robertson, of Lewis & Palmer, DeKalb, Ill.; S. W. Newburger, New Albany, Ind.; Mr. Briggs, Lamb Piano Co., Nashville, Tenn., and Mr. Jackson, of the Talking Machine Shop, Rockford, Ill.

P. G. Green, of Creighton, Neb., was a visiting dealer this week.

W. L. Eckhardt, manager of the Pennsylvania Talking Machine Co., in course of a trip that included Cleveland, Toledo and St. Louis, spent a day in Chicago.

Mr. Solomon is now touring Europe on a buying trip which includes a number of musical instruments.

George Israel, buyer for the talking machine department at Hillman's, has returned from a short business trip to New York.

Manager McCann, of the talking machine department of Rothschild's, is the proud father of a baby girl.

Mr. Patten, who is buyer for the talking machine department of the Boston Store, has just returned from a business trip to New York.

R. J. Nathanson, who for the past four years has been connected with the Universal Film Co., has decided to re-embark in the talking machine trade and is connected with Hillman's.

Phonograph Co. Items.

C. E. Goodwin, manager of the Phonograph Co., reports an excellent Edison disc business both wholesale and retail. He says that the great bulk of the business is on the higher-priced machine

LYON & HEALY AD. THAT HAS ATTRACTED MUCH ATTENTION.

(Special to The Talking Machine World.)

CHICAGO, ILL., March 10.—An advertisement that might serve as a model for talking machine

The ad is laid out in a masterly fashion and the argument is convincing and sincere. The illustration by Earl Hildebrand is good, and there is

Resources of the VICTROLA

The Ever Ready Home Orchestra

for Dancing



A Special Service

We are prepared to render genuine assistance to anyone interested in dancing. We have made an exhaustive study of dance music as applied to modern conditions and we have a staff of trained salespeople who can tell you in a moment things which it would require much effort for you to ferret out for yourself. In addition to all the exceedingly popular and somewhat hackneyed numbers, we have a list of dances equally charming, but not so well known, which we will be glad to play upon request.

A Victrola, by means of its changeable needle, can play dance music practically as loud as the original or as soft as a whisper, this without destroying the beauty of the records by means of a shutter. You can use either a concert needle, a loud needle, a medium needle, or a bamboo needle.

Every home should be equipped with a Victrola. The price, considering its service, is purely nominal. Think what a Victrola means—Grand Opera every evening; Caruso and the Stars; all the greatest Entertainers; all the greatest Bands; all the greatest Soloists; and, finally, music for dancing as soft or as loud as you would like to have it by means of the needle control, and as perfect in time as the Metronome itself.

Something must wear—in the Victrola it's the changeable needle and not the record.

Caruso, Keffe, Mabe and many other great stars can be heard only on VICTROLA records. Remember this—and avoid counterfeits.

VICTROLAS SELL FROM \$15 to \$250. EASY TERMS

World's Largest Music House

Lyon & Healy

Wabash Avenue and Adams Street

12 New Dance Records of Exceptional Merit

17534—Carmen, Oudon, Sardinia, Waltz, Berlin.

17535—La Danzante, T. Ser. Trio, 1st, Warsaw, Berlin.

17536—The Viper Dance, Oudon, Berlin.

17537—All About the Ballet, 1st, 19th, Victor, Berlin.

17538—Girl on the Beach, 1st, 19th, Victor, Berlin.

17539—The Viper Dance, Oudon, Berlin.

17540—The Viper Dance, Oudon, Berlin.

17541—The Viper Dance, Oudon, Berlin.

17542—The Viper Dance, Oudon, Berlin.

17543—The Viper Dance, Oudon, Berlin.

17544—The Viper Dance, Oudon, Berlin.

17545—The Viper Dance, Oudon, Berlin.

17546—The Viper Dance, Oudon, Berlin.

17547—The Viper Dance, Oudon, Berlin.

17548—The Viper Dance, Oudon, Berlin.

17549—The Viper Dance, Oudon, Berlin.

17550—The Viper Dance, Oudon, Berlin.

Hundreds of others now ready to be heard.

The Chicago Edison Jobber

The perfection of Musical Instruments—**THE EDISON** diamond disc **PHONOGRAPH**—with **EDISON** double disc records.

THE PERFECTION OF SERVICE—Our Service.

The Perfection of advertising for the dealer—Our plan.

The Phonograph Company
229 So. Wabash Ave. CHICAGO

dealers, not only in Chicago, but in a number of other cities in the country, is the one herewith reproduced, which was shown in the Chicago daily papers a few days ago.

not too much of it. A number of advertisements might be criticised because of the fact that the illustration, by reason of its preponderance, has detracted from the "pulling power" of the copy.

The Edison disc concerts in the handsome recital hall on the third floor run from 11:30 a. m. to 5 p. m. and much of the time run to S. R. O. Mrs. Helen Louise Essen gives brief talks on the records and also a brief sketch of the artist.

Manager Wayne, of the retail, recently made an addition to his staff in the person of Mr. Tipton who comes from Nebraska and is making good.

Elect Officers.

The annual meeting of the stockholders of the Permanent Phonograph Disc Needle Co. was held at the Hotel LaSalle. Samuel Levin, the inventor of the needle, was elected vice-president and manager with power to act, and his son, Lester L. Levin, was made assistant.

S. O. Wade Optimistic.

S. O. Wade, manager of Wade & Wade, recently returned from an extensive trip through Iowa and other of the Western States and expresses it as his belief that there is every indication of a decided improvement and an increase in business that bids fair to break even the record of business done in January. Great credit is given the Wade fibre needle cutter by a number of dealers who have recently begun to specify that all records taken out on approval shall be played only with

fibre needles and trimmed with the Wade cutter, thus guarding against damaging the records.

Buys Evanston Shops.

W. E. Erickson, talking machine dealer of Evanston, has bought the Evanston Talking Machine Co. and will continue to operate it under the old name. Douglas Oriwig has been placed in charge of the new acquisition and Miss Steel, in charge of the other.

Miss McClelland Marries.

Miss Ella McClelland, who has been connected with the Victor department of the Bisell-Weisert Co. for quite a length of time, has resigned her position and will be married soon. Just who the lucky man is, is not divulged. Miss Blatch, formerly of Lyon & Healy's, has taken Miss McClelland's place.

Opens New Store.

The Wulschner-Stewart Music Co., of Indianapolis, Ind., has opened a general music store at 35 South Wabash avenue. An extensive stock of talking machines and records is displayed. Stock has evidently been brought from Indianapolis, and in all probability, the store will not continue as a Victor store after present stock is exhausted.

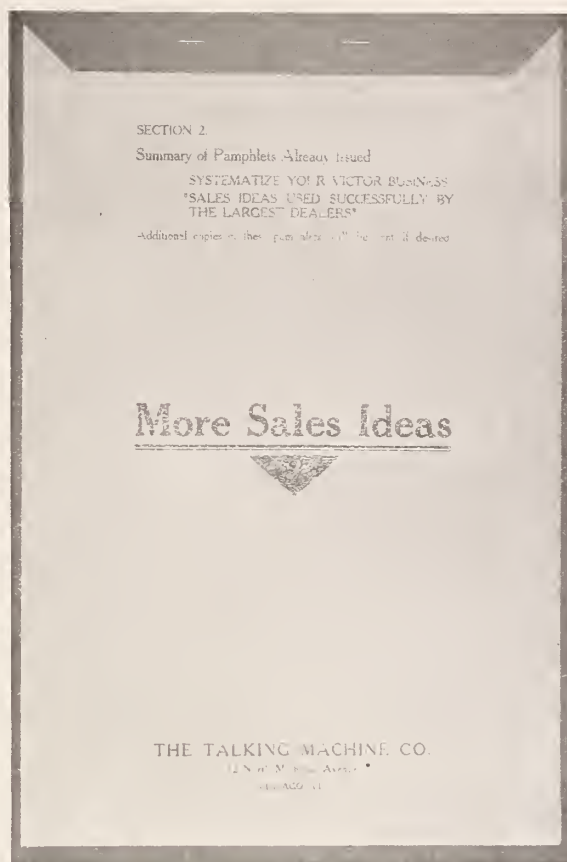
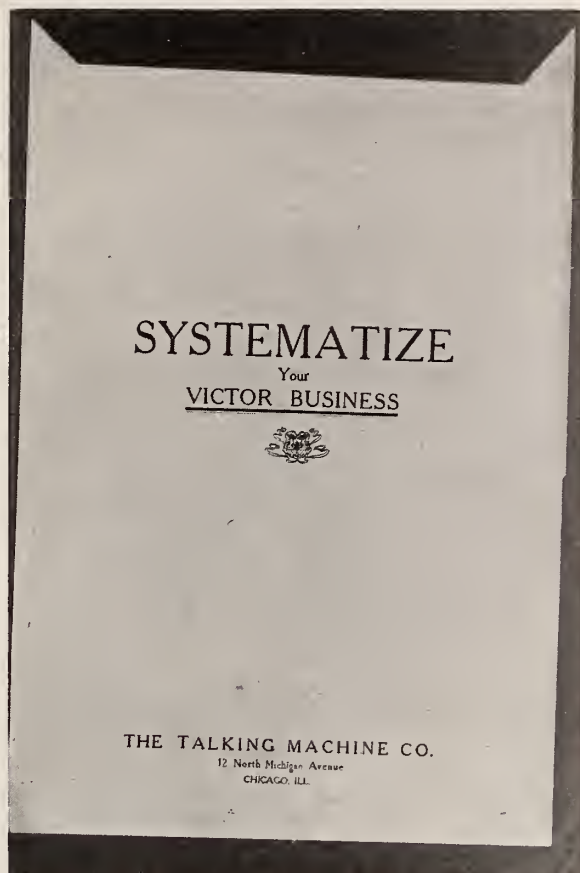

Are You On Our Mailing List?

If not, you are missing several letters a month in which are embodied different SALES IDEAS collected through the broad experience of the LARGEST EXCLUSIVE WHOLE-SALER OF VICTOR GOODS.

The above illustrations give you an idea of regular pamphlets we are issuing from time to time to our dealers.

EACH LETTER BRINGS SOME SALES IDEA—some new thought that we have gathered from our dealers. All may not be new to you and probably you have used a majority of them successfully—but ONE NEW IDEA GAINED IS WORTH THE EFFORT of writing us now and asking us to PUT YOUR NAME on our list of INTERESTED Victor dealers.

THE TALKING MACHINE COMPANY
 12 N. Michigan Avenue Chicago, Ill.

FROM OUR CHICAGO HEADQUARTERS—(Continued from page 34).

USES VICTROLA IN CHURCH.

Chicago Congregation Much Pleased with Novelty—Rector Testifies to Musical Qualities of Instrument in Interesting Letter.

(Special to The Talking Machine World.)

CHICAGO, ILL., March 10.—One of the most interesting uses to which the talking machine has been put in Chicago for a long time was when the Rev. Arthur J. Francis, rector of the Pilgrim Congregational Church of this city, held his regular Sunday service, at which a Victrola did a great part of the work.

The numbers in the service that were rendered through the use of the talking machine were as follows:

- EVENING SERVICE, 7:45.
- Hymn Solo—"My Jesus, I Love Thee"..... Sung by Frederic C. Freemantle.
- Hymn Solo—"One Sweetly Solemn Thought"..... Sung by Frank C. Stanley
- Prayer—
- Prayer Song—"Lord, I'm Coming Home"..... Sung by Frederic C. Freemantle.
- The Lord's Prayer—
- Piano Solo—"Berceuse"..... Chopin, Op. 57
Played by Frank LaForge.
- Duet—"Contes d'Hoffman—Barcarole"..... Offenbach
Sung by Farrar and Scotti
- Quartette—"Festival Te Deum, E flat"..... Dudley Buck
Sung by Trinity Church Choir, New York City
- Offertory Solo—"Ring Out Wild Bells"..... Gounod
Sung by David Bispham
- Sextette from "Lucia di Lammermoor"..... Donizetti
Sung by Tetrzzini, Caruso, Journet, Jacoby, Bada and Anato.
- Soprano Solo—"The Swiss Echo Song"..... Eckert
Sung by Louisa Tetrzzini
- Benediction—
- Benediction Solo—"Cavatina"..... Raff, Op. 85
Played by Mischa Elman

After the service a number of the congregation spoke to the Rev. Mr. Francis and expressed their delight with the novelty of the service and their enjoyment of his very interesting address. So numerous were the expressions of approval of the part that the Victor had played that the Rev. Mr. Francis has decided to make it a monthly feature.

The machine was supplied by the George P. Bent Co. and was operated by Harry C. Meek. The machine was equipped with a new device known as the "Clear-a-phone" which was invented by Mr. Scotford, a friend of the rector. The satisfaction of the Rev. Mr. Francis is best expressed in the following letter to Mr. Meek.

"My dear Mr. Meek.—The Victor Victrola Service held in Pilgrim Congregational Church, Sunday evening, March 1, was a very great success and an exceedingly impressive service.

"I am free to confess that I engaged to carry through this service with more or less timidity. Innovation is rather shunned by me, but certainly this service proved to be all that could possibly be wished as an aid to the beautiful and the worshipful.

"In such a service, however, it must be borne in mind that nothing, but the best ought to be used. The best in solos, duets, quartets, and musical selections. With this as a working principle I do not hesitate to say that any church would do well to consider adopting such a service. We are anticipating a monthly service of this character, so happy were we over our first endeavor. With sincere regards, I am, yours always,
"ARTHUR J. FRANCIS."

INSPECTING MECHANICAL DEVICES.

Secrecy is a lost art, says the editor of the American Machinist. It is useless to go over the arguments, real or alleged, for no matter what we may think about it personally, secrecy, at the present time, is as impossible in most shops as the fourth dimension. There is a lot of good energy wasted in attempting to preserve secrecy in the shop, and this is doubly true of the machine after it is on the market. A recent occurrence showed the way in which salesmen lose their heads, and incidentally, customers. A visitor to an exhibition evinced considerable interest in the machines shown, and asked a number of leading questions. Knowing the attitude of the average salesman, he declined to give his name. It was soon discovered that he was a designer for a large machine builder with the result that he was promptly invited to go elsewhere.

It so happened that the manager was broad and level-headed and he proceeded to show the salesman the short-sightedness of his policy. He explained how foolish it was to try to hide anything about a machine which was on the market and could be seen, studied and even measured in a dozen shops; how, if the competitor really wanted to know, he would buy a machine and take it apart, as is often done. He tried to make clear the utter foolishness of attempted secrecy and the advantage of an interchange of ideas.

If a machine will not bear the inspection and criticism of competitors it had better never see the light of day, as they will find its weak spots anyhow, and not forget to mention them either. Secrecy in the great majority of cases is unwarranted, unsuccessful and goes hand in hand with inefficiency. Those who fear that others will steal their ideas seldom have anything which the really up-to-date shop can use. And many devices which are now jealously guarded were long ago abandoned by others.

AFTER CHINESE RECORD TRADE.

(Special to The Talking Machine World.)

CHICAGO, ILL., March 10.—Sim Law, of 2209 Princeton avenue, this city, has built up an immense record trade among his constituency and his lists, which he sends out in Chinese, are most interesting. For instance, the accompanying is a list of Edison Blue Amberola records which he recently

民國七年二月二日
 敬者弟現辦到曉地善公司最新欸之藍色店寶
 唱筒每個五毫若英屬六毫該筒能唱四箇半至
 五箇尾利之久此筒以前之臘筒有特別堅固唱
 之不爛永久不變須唱三千餘回亦即原底一樣
 也况聲音響亮玲瓏清楚令人聽之不厭至唱筒
 之機係無角唱頭用正鑽石永遠不用換針免廢
 時候(如舊臘筒切不可用)此機每架三十圓至
 二百五十圓內三十圓至四十五圓極合我華人
 之用或過埠回唐易于携帶現有各班子弟唱曲
 全套數十本隨後陸續有到如 貴客賜顧祈將
 上列之門牌寄來定然照辦妥當付上此佈
 弟羅逢怡告白

Edison Blue Amberol List.

sent his customers and in which he is receiving large orders. Record trade among the foreign element in the United States is steadily growing and they keenly enjoy songs and recitations in their own language.

NEW DEVICE TO IMPROVE TONE.

The "Clear-a-phone," the Invention of a Chicago Man, Embodies a Number of New Ideas—Much Claimed for It—Patent Applied For.

(Special to The Talking Machine World.)

CHICAGO, ILL., March 10.—A novel device along comparatively new lines that is designed to improve the tone and volume of the talking machine is the "Clear-a-phone" the invention of L. K. Scotford of this city.

The "Clear-a-phone" consists of a pneumatic cushion, circular in form that is made of first quality rubber 12% inches in diameter, one-thirty-seconds of an inch thick. It has an aluminum base and there is an air space between the base and the rubber top three-eighths of an inch deep.

"We claim that it clears up the tone of the instrument such as no other improvement can. It brings out the quality of each voice or instrument, removes the hissing and blasting of the high notes, improving the resonance and otherwise taking the 'can' out of 'canned' music. It also counteracts the natural vibration of the record.

"We have our device in the Patent Office now and hope to market it in a short time."

The inventor, Mr. Scotford, is president of the Superior Type Supply Co. and also has large interests in the East.

THE CONCERT.

The night shall be filled with music,
 And the cares that infest the day
 Shall be multiplied by twilight
 In a most amazing way.
 The strains of "Traviata"
 Shall float around the square,
 With many another opera
 And old familiar air.

The man in No. 7
 Will play "The Magic Flute,"
 And the fellow on the corridor
 Will make a tooter toot.
 The great tones of Caruso
 Shall rise above the blast,
 And the din shall last till 9 o'clock
 Or thirty minutes past.

The man in 27
 Will turn on "Casey Jones,"
 And the whole apartment house shall rock
 With consequential groans.
 The night shall be filled with music,
 And the cares that infest the day
 Shall be multiplied at twilight
 In a most amazing way.

—From the St. Louis Post-Despatch.

BUILDING UP A SUCCESSFUL BUSINESS IN CHICAGO.



Joseph Klinenberg's Store on Ashland Avenue.

(Special to The Talking Machine World.)
 CHICAGO, ILL., March 8.—One of the enterprising dealers in Edison disc and cylinder phonographs and records in this city is Joseph Klinenberg, whose establishment is located at 4915 South Ashland avenue. He has attractive display and soundproof rooms, where the Edison line is shown to advantage. He also handles the Jesse French & Sons Co. pianos and players, and is a strong believer in the one-price policy of retailing pianos, having won success along these lines in conducting his piano business.

RECORD FEBRUARY BUSINESS IN NEW YORK CITY TRADE

Despite Scarcity of Both Machines and Records Jobbers and Dealers Handle Big Volume of Sales—Big Increase in Columbia Retail Trade—V. W. Moody Optimistic—Landay Bros.' New Store Soon to Open—Blackman Co. Grand Opera Record Demand.

A continued scarcity of machines and records, together with the closing of the best February business the trade has ever experienced, have been the most important features of business the past month. The word scarcity is used advisedly, as many of the local jobbers and dealers have drawn a distinction between a shortage and a scarcity of goods. They state that a shortage of product would necessitate the closing of less business than last year, while with a scarcity of machines and records the trade can still transact a better business than that closed in 1913, owing to the fact that there have been heavier shipments from the factories than ever before.

Aside from the scarcity of product, the most discussed topic among the local members of the trade has been the phenomenal demand for records. In addition to the dance craze, which shows no signs of abating, the dealers have been developing, both from choice and necessity, their trade in operatic and light opera records. The swamping of the factories with dance records orders has been so emphatic that the up-to-date and aggressive dealers are beginning to realize that their record trade will show a comparative loss if they do not pay attention to all classes of music and give the factories a chance to catch up with the back orders for dance records. In the meantime practically every dealer in the local trade closed in February the best month's record business ever experienced.

The situation in machines has cleared up somewhat during the past few weeks, the factories sending large shipments to their distributors that in many instances were shipped from the sidewalk to the dealers without being unpacked or placed in the distributor's stock room. The call for the moderate priced machines continues to take precedence over the very cheap and the more expensive types, machines selling from \$50 to \$150 being the heavy sellers at the present time.

The past month has witnessed an unusual activity in the consummation of many important new deals by all three companies. The prosperity of the talking machine industry is well evidenced by all these new connections, and, as a matter of fact, there are numerous applications on file for territorial rights that cannot be filled for some time to come, owing to the scarcity of stock and the inability of the companies to turn out enough machines and records for their present dealers. There seems to be a fast growing tendency on the part of the manufacturers to close dealers' agreements with the best known piano houses wherever territorial arrangements will permit. There is no doubt but that the piano store offers a splendid opportunity for the presentation of the talking machine, and the marked success of the leading piano houses throughout the country who have conducted talking machine departments for some time indicates that profitable results can be obtained when there is co-operation between the piano and "talker" sections. In a number of instances substantial player and piano sales have been closed as the result of the visits of talking machine patrons to a piano store.

Reports Gain of 63 Per Cent.

"We showed a gain of sixty-three per cent. over last February," said R. F. Bolton, manager of the wholesale store of the Columbia Graphophone Co.,

89 Chambers street, New York. "We were well pleased with this substantial gain, particularly in view of the fact that heavy storms ranging at frequent intervals during the month would naturally form good ground for pessimism. On the contrary, however, our business was excellent and the deals we closed in February represented new acquisitions to our representatives' lists that are most gratifying. Our dealers throughout the State all report the same phenomenal demand for dance records that was a feature of January business. Personally, I believe that the dance record craze will be with us for some time, and all indications point to an excellent summer business because of it. There will be very few house parties during the summer that will care to dispense with the latest dance music, and the live-wire dealer should be in a position to handle this summer business to the best possible advantage. Aside from its influence on record sales, this dance craze has evidenced itself in the steady increase of machine sales now being closed by the dealers. A lover of the modern dances is offered no better investment than that of a Grafonola with a selection of the latest Columbia dance records to satisfy his love for the modern dances, and, judging from the reports of our dealers, the 'Favorite,' 'Leader' and 'New Mignonette' are heavy sellers among dance lovers."

Why V. W. Moody Is Optimistic.

Notwithstanding the marked scarcity of Victor machines and records, there is one optimist in the local Victor distributing trade in the person of V. W. Moody, sales manager of the New York Talking Machine Co., 81 Chambers street, New York, who remarked as follows: "Although there is undoubtedly a tremendous scarcity of goods at the present time, it would hardly be fair to the Victor Co. to call it a shortage of goods, as we are receiving more machines and records from the factory than we ever received before, and selling more goods than ever before, but our stock report shows less on hand than ever before. Our shipments of new Victor records for March, together with the shipments of the special dance records put on sale during February, amounted to almost twice as many records as were purchased from the Victor Co. in the corresponding month last year. In addition to these shipments of newly issued records we received, of course, thousands of records from the regular catalog during the course of the month. I need hardly say that this February was the best in our history, as we closed a business that almost equalled our usual fall trade."

Excellent Edison Disc Trade.

"Our sales of machines during the past few weeks have been remarkable," said H. N. Purdy, of the Edison disc department of Hardman, Peck & Co., 433 Fifth avenue, New York. "We have really been surprised at the extent of our Edison disc machine trade, and notwithstanding that weather conditions were detrimental to retail trade during February, we closed a splendid machine business. The favorite Edison machine in our department is the \$200 type, and this preference of an expensive machine is a good illustration of the discriminating class of patrons that we cater to. We sell very few machines that retail for less than \$150, our customers appreciating the fact that the prices asked for the Edison disc machines are most

reasonable, considering their musical qualities."

Have Attracted Attention.

During the past few weeks the Columbia Graphophone Co. has had its products represented at the handsome store of the Melville Clark Piano Co., 335 Fifth avenue, New York, where they have attracted general praise and attention from passers-by along this high-class shopping thoroughfare. Many sales of machines have been closed in these warerooms and the new Columbia dance records are meeting with a ready sale with Columbia enthusiasts, who find this store on Fifth avenue a very handy place to secure some of the latest dance records.

Landay's New Store.

When this issue of The Talking Machine World is off the press the handsome new store of Landay Bros., the prominent Victor distributors, will in all likelihood be open to the public. Located at 427 Fifth avenue, New York, opposite the new Lord & Taylor store, between Thirty-eighth and Thirtieth streets, this store has been furnished in an artistic and refined manner. The new Landay store is probably one of the finest Victor establishments in the country. Eleven demonstration rooms, larger than most rooms of this nature, have been constructed on the main and mezzanine floors. These rooms are finished in typical French style, the color design being a gray and green, delicately blending to harmonize with the other artistic decorations. Every possible convenience is available for the use of the store's patrons, and this store takes its place as a tribute to the enterprise and progressiveness of Landay Bros., whose other stores in the centers of the city's very best shopping districts have all achieved marked successes. Roy Forbes, now connected with the Landay store at 400 Fifth avenue, will be manager of the new store.

Coincident with the opening of the store at 427 Fifth avenue, the Landay store at 400 Fifth avenue, a block further down, will be formally closed. With the closing of this store there passes into history one of the old land marks of the talking machine industry. It was to this house, many years ago, that Thomas A. Edison brought his very first tinfoil phonograph so that his old friend, Robert Ingersoll, the famous philosopher and writer, who lived there at that time, could speak into it and make history for future generations.

Activity at Blackman's.

"Our grand opera records are selling better than ever," said J. Newcomb Blackman, president of the Blackman Talking Machine Co., 97 Chambers street, New York, the prominent Victor and Edison cylinder jobbers. "Our dealers have turned their attention from the dance records to the opera records, appreciating that the shortage in stock of the dance selections should not hold them back from expanding their trade in the more expensive records. We are well pleased with the demand for our Cleanrite Brush No. 4, which is a combination brush for use on all Edison cylinder machines. We are having these brushes manufactured in large quantities and are now in a position to adequately take care of the demands of our trade."

Encouraging business reports, similar to those outlined above, were given The World representative by the following dealers: Tower Manufacturing & Novelty Co., Edison disc; Benj. Switky, Victor; F. G. Smith, Columbia; Gimbel Bros., Victor and Columbia; Greenhut-Siegel Cooper Co., Victor and Edison cylinder; John Wanamaker, Victor; B. Guy Warner, Edison disc; Kranich & Bach, Columbia; A. I. Namm & Sons, Edison disc; Hallet & Davis, Victor; Lord & Taylor, Victor.

Send 50 cents in stamps for sample "Standard Fibre Needle Cutter." The easiest selling accessory ever offered the trade. [Appeals to the women buyers. Retains chips. Artistic. Built like a watch. Compact. Powerful. Liberal discounts. Order through your jobber.

**STANDARD GRAMAPHONE APPLIANCE CO.
173 LAFAYETTE STREET, NEW YORK CITY**



Jeanne Gerville-Reache, the famous French contralto, is the latest exclusive Columbia artist. Her "Samson and Delilah" record is already being talked about.



(Write for "Music Money," a book "full of meat" for those dealers interested in quick and frequent turnover of capital.)

Columbia Graphophone Company
Woolworth Building, New York

CALL FOR DANCE RECORDS FACTOR IN ST. LOUIS TRADE

Craze for the One-Step and Tango Serves to Increase Both Machine and Record Sales—Records of Popular Music Becoming Strong Favorites—Story of a Reaction—Grand Opera Season Expected to Help Business—What Various Houses Report for Month.

(Special to The Talking Machine World.)

St. Louis, Mo., March 10.—The dance records are still holding high favor with local buyers, and are the feature of the talking machine business as it is running to-day. The demand simply seems to be insatiable, and both Victor and Edison disc shelves show a pitiable degree of barrenness. The Columbia stocks thus far have been equal to demands.

It is reported among talking machine dealers that some of the tango parties that are given with the aid of a talking machine as an orchestra would make excellent Sunday magazine feature stuff. The tendency of the present vogue dances to undress appearance has raised such a storm of criticism that all such as are conducted in public are strictly proper, but with a talking machine, a bunch of records and a select party of trusted dancers all things are possible, and guests are careful about their selection of lingerie.

There is a story told of a local talking machine house that has some well-secluded record demonstration rooms. A party of wealthy and well-known women were left in one of these rooms by a busy salesman to pick out a selection of tango records. Later the manager was hurriedly summoned by a very youthful and very serious salesman to go to the demonstration rooms, "where a bunch of women were acting plumb nutty." The manager was busy and tried to turn away the summons, but the salesman insisted, and finally he went there. As he appeared the hilarity stopped and the women explained that they were merely trying out some tango records and hoped they "had not disgraced the house, but we did not think that nice boy would tell on us."

But the business is not altogether records. There is a fine, healthy machine demand, mostly for high-priced machines. The dances are but a part of the impetus that has been given the talking machine trade, and dealers who in the past have set their mark at doubling the last year's business are looking forward to a treble amount for 1914 over 1913.

Manager Robinson, at the Thiebes Piano Co., says of the trade's new tendencies: "The demand is turning more and more to popular music. I remember when we used to take a little machine and nail it to the top of a door and put on popular records as an advertisement. They were raw, too raw to sell. When the trade developed, everybody who bought a machine wanted real music, Caruso and records of that kind, and for years we sailed along appealing to the real lovers of music and real music records. Now we have interested the other crowd, the one we started for, and they are simply coming in droves. Talking machine music is considered better by these people now than their own music that any ear player can grind out on a piano or a cheap orchestra. It means a big business to convert this popular class that we once failed on but who now come voluntarily.

"Of course we are selling more good music as we go along. The proportion of that sort of music to the total of records sold is greatly less than it was a year ago, and still smaller in proportion than two years ago. It means that everybody is listening to talking machines or will be as soon as the factories can turn out the machines and the records."

Harry Levy, talking machine manager at Aeolian Hall, who is confined to Victor goods, says: "Our business is limited only to our ability to fill orders, wholesale and retail. The retail department has simply been swamped by requests for dance and other popular records. Of course that indicates the position of other dealers. We thought that when we had performed the problems in division that the Christmas trade forced onto us we had completed the course in fractions for several months, but if anything it is worse than ever. Some styles of machines can be had, but it is beyond the dreams of salesmanship to supply all sorts of trade with a few styles of machines, and there we have trouble. We simply do the best we can with the records and try to forget each evening."

The grand opera season reaches here next month, and Retail Manager Duffy, at the Columbia, is congratulating himself on the pickings for his records.

"We have Garden, White, Zepelli and Dufranne on our list," he said, "and we think they will prove popular. There is a light advance demand, but the history of these things shows that the big demand comes afterward, when the listeners can conjure up scenes from the actual opera. We have been doing very well indeed with Teyte and Ysaye records since the appearance of these two artists here. Both of these always have proved good record advertisers for us.

"The best things with us now, however, is our stock of the popular dance records. We have been supplying all comers despite the unexpectedly and very heavy continued demand for these records.

"The machine business has been very good indeed, better than we had anticipated, and we are piling up some nice totals for merchandising."

Manager Robinson, of Thiebes, proudly reported the sale of a horn Victor machine the first of the month, the first new machine of this kind sent out for some time. Its appearance in the delivery room caused consternation. It was a street car delivery and none of the force knew anything about carrying horns on a street car. They had forgotten the days when a delivery boy on a car platform with a horn was a familiar sight.

L. Benton Prince is a recent addition to the Thiebes Piano Co. talking machine sales staff.

Weekly meetings have become a fixed feature of the saleswork of the Victor department at the Vandervoort Salon. Manager R. A. Seagar has a force of twenty-two persons, and he finds the interchange of ideas very profitable. One of his recent business getters is a force of seven men to

LONG CABINETS

Occupy a strong position.
They have many friends.

The Geo. A. Long Cabinet Co.

Write for Circulars of
RECORD CABINETS
and
PLAYER ROLL CABINETS

Address

Clement Beecroft, Sales Manager

309 W. Susquehanna Avenue
PHILADELPHIA, PA.

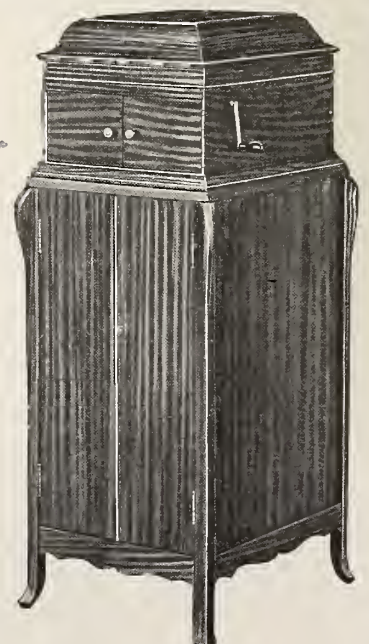

D 67

Mahogany, Golden Oak and W. O. Finished all around. Sliding Record Shelf. For IX Victrolas. Capacity, 192 12-in. Records.

canvass a district to ascertain what homes have talking machines and to pick up prospects. Behind this force are two expert salesmen, who close the deals and put in the machines. H. J. Harrison, of the sales force, is devoting his entire time to the schools.

Mr. Seagar announces a series of Tuesday afternoon concerts under the auspices of Victor Lichtenstein, of the Symphony Orchestra. The programs will take up one at a time the operas to be given here by the Chicago-Boston Company next month, and Mr. Lichtenstein will lecture on the music and demonstrate the music with talking machine records.

Manager Robinson, of the Stix, Baer & Fuller department, reports excellent business, and he is much elated at the prospect of immediate consolidation of his department with that of the piano department, where the musical instrument interests of the firm will be centered. In his efforts so far he has been considerably handicapped by an out-of-the-way location on the fifth floor.

At the Edison Shop they are talking of big things these days, such as new dealers on the wholesale list, of the promised day very soon when record orders will be shipped 100 per cent. when promises made in recent factory advices are fulfilled, and of Sunday magazine pages that are filled with President Mark Silverstone's talk on Thomas Edison as a host, a man that the everyday business man meets at the factory and a truly human institution instead of the marvelous working machine that the people have read so much about.

This magazine page was a splendid feature of the Post-Dispatch Sunday paper. After Mr. Silverstone's visit to the factory for Mr. Edison's notable birthday party he told a newspaper writer of the man he had met on that and previous visits, the man who was entirely human and who talked in language that sometimes required dashes. It made an excellent story coupled with an informal picture of Mr. Edison.

While Mr. Silverstone was at that birthday party the sales force at the Silverstone Edison Shop celebrated the birthday with a banquet for the sales force at the American Hotel. In the absence of President Silverstone, A. O. Reynolds presided, and all talked of the wonderful machine they were engaged in introducing to the public and of topics for the good of the business. After Mr. Silverstone's return Mr. Reynolds departed for Kansas, where he is sending frequent reports of new dealers who will sell the disc machines to the millionaire farmers of that great State.

C. S. Gardner, of the factory sales staff, was here for a few days to work with Mr. Silverstone, and then departed for the Silverstone trade territory in Illinois.

Of course there are some very good sales stories at the Silverstone store. A doctor was there the other day buying a machine, when the salesman told him of a doctor that had come in a few days before because he had become interested in a machine owned by a patient. "I can beat that," said the second doctor. "I am here because one of these machines made me forget a patient. I went to call on a patient the other day, and in the first room in the house that I visited I came across an Edison machine. I got interested and spent an hour there putting on and taking off records. At the end of that time I went upstairs to bid my patient good-bye, and she asked me with a smile: 'Did you come to see me or hear music?' I concluded I had better get a machine of my own and wear out my curiosity before I really neglected a patient."

Some of the new dealers on the Edison disc list are the Field-Lippman Piano Co., which handles the Victor in Piano Row; the Concordia Music House, which is moving from Eighteenth and Olive streets to 912 Pine street, only a block from Piano Row, Edison disc exclusive; C. A. Kleinhans, 2316 Chouteau avenue, city; Frank Halley, Louisiana, Mo.; Haynes A. Esbeck, Decatur, Ill.; Hornersville Music Co., Hornersville, Mo.; Harmony Music Co., Harmony, Kan.; J. H. Kayter, Nevada, Mo.; Wilson Bros., Aurora, Mo.; Rhodes Music Co., Lama, Mo.; Shellach Drug Co., Galena, Ill.; Charles Selig, Eldorado, Ill. It is intimated

that the St. Louis list is practically complete.

The jobbing business, Mr. Silverstone says, will show an increase each month, not excepting the December business, which Mr. Silverstone regards as material progress.

One of the recent would-be purchasers of an Edison machine offered to trade two town lots in Reno, Tex., for a suitable instrument.

WHY HE WANTED HYMNS "MADE."

A Danville, Ill., Man Offers Some Suggestions to the Columbia Co. Which Are Interestingly Put and Referred to the Record Department.

There is more logic and common sense to the following letter recently sent to the Columbia Graphophone Co. than would appear at a first glance. The appeal for music that can be easily understood is, undoubtedly, an excellent suggestion, but the company regretted its inability to record hymns to suit the fancy of each one of its many thousands of admirers.

"DANVILLE, ILLINOIS.

"Messrs. Columbia Graphophone Co.:

"Please let me know how much a dozen you would charge me for your double disc records? of the hymns that I will sand to you with musick al loud and plain, some that I will mark sung slow solmn. when the disk will not record the whold hymn be sure and use the last verse. the trouble with musick is the words of the Hymn cannot be well understood. and there is no com-

mon sence in musick that cannot be understood. Yours respectfully."

TALKING MACHINE IN CHURCH.

Chicago Pastor Illustrates Talk on Edison in a Thoroughly Effective Manner.

(Special to The Talking Machine World.)

CHICAGO, ILL., March 7.—The Rev. Arthur J. Francis, pastor of the Pilgrim Congregational Church, 6401 Harvard avenue, made use of a talking machine at his service last night to harmonize the musical program with his sermon on "Edison—His Value to Society."

"It was a great success," said Mr. Francis. "I shall probably use the machine at my evening services every other week from now on."

The church was packed.

In closing, the pastor said: "Where there is no vision the people perish," it is said. So long as America produces men like Thomas Edison, there is little danger of our perishing."

CATALOG OF REPAIR PARTS.

The Victor Talking Machine Co. sent out to its dealers this week new repair catalogs for Victrola XIV and XVI. The company also announced that it has secured a new style patented spring binder, which will accommodate about 200 pages, and is provided with an inside folder for retaining the repair part catalogs. This binder is much superior to the one formerly used.

YOUR OPPORTUNITY

HERE IT IS

If you are one of those VICTOR DEALERS who has not tried "BLACKMAN SERVICE," can you AFFORD to not try it NOW?

Will You Ignore It?

Will you simply GO WITHOUT records you need, or will you TRY BLACKMAN? We can't give you everything wanted, BUT our service will AT LEAST be a BIG LIFT.

Send a Trial Order

Make it two or three for A TEST, and we will take a chance on OUR SERVICE, when compared with others, making you a REGULAR BLACKMAN DEALER.

DON'T DOUBT UNTIL YOU TRY

Very sincerely

BLACKMAN TALKING MACHINE CO.

J. NEWCOMB BLACKMAN, Pres.

97 CHAMBERS ST., NEW YORK



HOWARD T. GRIFFITH HONORED.

Advertising Manager of the Udell Works Re-elected a Director of the Chamber of Commerce—Holds Other Important Offices.

(Special to The Talking Machine World.)

INDIANAPOLIS, IND., March 10.—Howard T. Griffith, advertising manager of the Udell Works, of this city, has been re-elected a member of the board of directors of the Indianapolis Chamber of Commerce for another year. The Chamber of Commerce of this city has been in existence for one year, with ninety-five directors, but this year the number was reduced to forty-five, and of the forty-five directors chosen at this time only twenty-nine were re-elected. So it seems that Mr. Griffith in his re-election has achieved an unusual distinction.

Mr. Griffith is also vice-chairman of the publicity division of the Indianapolis Chamber of Commerce, and will be one of the reception committee to entertain the central division convention of the Associated Advertising Clubs of America, to be held in this city April 9 to 11. Some of the biggest men in the advertising field will be present.

The Santa Fé Watch Co., Topeka, Kan., hustling Edison disc representative, is displaying in its show window an attractive photograph of Governor Hodges of Kansas listening to an Edison disc phonograph in his home. The Governor's son, also shown in this photograph, apparently enjoys good music equally as well as his distinguished father.



H. T. Griffith.

EXHIBIT AT BROOKLYN SHOW.

Frederick Loeser & Co. Has Attractive Display of Victrolas and Various Well-Known Accessories at Pure Food and Industrial Show in That Borough—Closing Many Sales.

A complete line of Victrolas is being displayed this week by Fred'k Loeser & Co., Brooklyn, N. Y., at its exhibit at the Pure Food and Industrial Exposition, which opened March 2 at the Thirteenth Regiment Armory, Brooklyn, N. Y. This show, which is visited by thousands of people during the two weeks that it is presented, is an ideal place for a Victrola display, and a number of sales of expensive machines have been closed during the course of the two weeks.

E. Paul Hamilton, manager of the Victor and music departments of Fred'k Loeser & Co., secured the exclusive rights to the musical instrument section of the show this year, and paid particular attention to the display of Victrola products. Demonstration booths were constructed for the Victor exhibit, and every possible convenience is afforded visitors to the show. The new Victor dance records are meeting with a ready sale, and the prestige and musical standing of the Victrola is featured to excellent advantage.

Other exhibits in the Loeser Victor display include a number of accessories, among which are the Standard automatic stop, Standard fibre needle cutter, "Masterphone" and others. These are all attracting favorable comment.

THE WINDOW A TRADE DEVELOPER.

Attractive Display at the Phonograph Co.'s Store in the Taylor Arcade, Cleveland, Wins Praise from Visitors and the General Public.

(Special to The Talking Machine World.)

CLEVELAND, O., March 10.—The illustration herewith conveys an excellent idea of the window of The Phonograph Co.'s branch store in the Taylor Arcade, this city. The design is elaborate and attractive, and appeals unflinchingly to the thousands

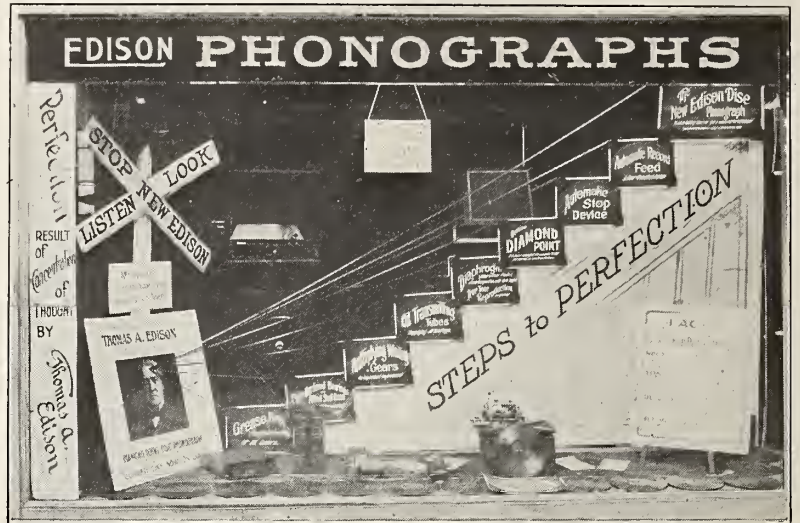

Unusual Window Display of the Phonograph Co., Cleveland.

who daily pass through the Arcade. The value of a well considered window display is accentuated by the way this window attracts and holds people, thus proving an advertising medium of tremendous value.

You must learn not to overwork a dollar any more than you would a horse. Three per cent. is a small load for it to draw; six, a safe one, when it pulls in ten for you it's like working some place where you've got to watch to see that it doesn't buck.

Another Example of \$witky \$ervice

Victrolas XI Growing Scarce

But Our Dealers Need Not Worry

¶ Last summer we foresaw the condition that is coming. We took in all the Elevenths that the Victor factory could ship us, besides buying up a lot from other sources during the dull season.

¶ Although warehouse charges, interest and insurance have cut into the margin of profit, it was your benefit only that we thought of.

Order Now—Order Liberally.

Telephone! Telegraph! Write! Get Busy!

**BENJ. SWITKY, VICTOR DISTRIBUTOR
NEW YORK CITY**

TO REMODEL ST. LOUIS QUARTERS.

Elaborate Plans Made for Housing Columbia Co. Branch in That City to Better Advantage—Recent Visitors—Managerial Changes.

(Special to The Talking Machine World.)

St. Louis, Mo., March 9.—Manager Irby W Reid, of the Columbia warerooms here, announces with a great deal of satisfaction that his store will not be compelled to hunt new quarters, as has been expected for several months. A year or more ago tenants of the property of which the Columbia store at 1008 Olive street is a part were informed that the buildings there were going to be wrecked. Several stores, including the Detmer Music Co. and the Silverstone Music Co., removed as their leases expired.

Now the prospect has changed and the Columbia Co. not only is going to stay in the present quarters, but the building will be entirely remodeled and renovated and made into an attractive and convenient store. The location is in the center of the district that has been known as the St. Louis headquarters for talking machines for a long time. The change also will give to the Columbia the additional space that has been needed for a long time. Recently this company has been leasing additional warerooms in the neighborhood.

Among other changes will be the removal of the Dictaphone department to the second floor. The offices will remain on the first floor, but will be remodeled for economy of space and efficiency. Stock and showrooms will be on the second floor.

Walter L. Eckhardt, of the Pennsylvania Talking Machine Co., was here the first of the month on a social visit and assisted Mr. Reid in making the plans for his new store with a view of getting the most out of the space.

J. J. Bennett, traveler for the Columbia Co., is back from a Northern trip and reports excellent trade. He reports new contracts with Allen Jewelry Co., Roodhouse, Ill.; George W. Brown, Jr., Hillsboro, Ill.; S. G. Smith, Jr., Edwardsville, Ill., Lombard Piano Co., 3540 Olive street, St. Louis.

Mr. Bennett says one of the marked developments of recent trade is the demand for foreign records and that his business in these records has increased fully 25 per cent. within three months.

R. S. Odell, of the Columbia sales staff, has been engaged as manager of the talking machine department at the F. G. Smith Piano Co. in the place of C. W. Smith, who left the Smith Co. to take charge of the talking machine department of the Sommers Furniture Co., also an exclusive Columbia agency. Mr. Odell will continue the policy of the F. G. Smith Co. to give occasional concerts, his next one being announced for March 27.

LISTS OF CREDITORS TOO LONG.

Causes That Lead Merchants to Expand Business Relations to the Danger Point—Better to Be Strong with Few Than Weak with Many—Suggestions Regarding Credit.

It is a rare business failure that does not show a list of creditors at least twice as long as it should be. It may be that a credit stringency was the cause; that in order to "keep going" it became necessary to go from one house to another until the list was swollen beyond all reasonable proportion. But it is very often the other way round; the many creditors come first, and the stringency follows swiftly enough.

The thing to do is to confine your business to as few firms as you can with justice to your stock. The merchant who does this makes his business important to his wholesalers. They are ready to give him of their very best efforts; he has their confidence; they are anxious to co-operate with him in every possible way because it is to their best interests to do so.

Don't split your business. Be strong with the few rather than weak with the many. This does not mean that you should not have two or possibly three lines of the same grades; that may be necessary enough to get the selection you want. It does mean that you should not have six or seven or more of the same grades—a smattering of everything. That is not necessary; it weakens credit and is an injustice to every line represented.

A. D. MATTHEWS' SONS IN LINE.

Brooklyn Department Store Opens Columbia Department with Harold Tuers in Charge.

The Columbia Graphophone Co. further increased its strong representation in Brooklyn, N. Y., last week, by closing arrangements with A. D. Matthews' Sons, Inc., whereby this prominent dry goods and department store opens a handsome Columbia department on the third floor of its building in the center of Brooklyn's busiest shopping section.

It is planned to have a complete stock of machines and records on hand in this department at all times, and to this end unusually large record racks and display rooms have been constructed. The department will feature six booths for demonstration purposes, all furnished in a comfortable home-like manner. Harold Tuers, formerly connected with the Twenty-third street store of the Columbia Co., is in charge of this Columbia department.

VACATION WEARIES EDISON.

Inventor Orders Phonograph Records Sent to Him in Florida.

Thomas A. Edison wrote to his personal representative, William H. Meadowcroft, in West Orange, N. J., this week, to send a large consignment of disc phonograph records and a machine to Mr. Edison's winter home at Fort Meyer, Fla.

"I can't feel right until I have some records and a machine with me," he wrote. "My friends here, Mr. Ford and Mr. Burroughs, I guess, will think me a quitter, but as soon as I have listened to the phonograph for a while, I will go with them to the Everglades and study bird life there."

EDISON DISC OUTFIT FOR ELKS.

The Elks Lodge of Green Bay, Wis., purchased an Edison disc phonograph last week after the members by a vote of 53 to 14 had expressed themselves in favor of this machine.

HOW ADVERTISING PAYS.

The Clever Publicity and Follow-up System of the Columbia Co. Bears Fruit in New Agents—Makes Most Favorable Impression on the Trade Throughout Country.

The advertising campaign being waged by the Columbia Graphophone Co. is undoubtedly one of the features of the talking machine industry at the present time. Impressive and strong in its appeal, this advertising has been generally commended by many members of the trade and has even attracted the attention of advertising experts throughout the country.

That this publicity campaign has been successful is indeed a tribute to its force and strength, but in the achieving of this success probably the most important factor has been the aggressiveness of the company's follow-up campaign. It is the motto of the advertising department of the company to make sure that everything that goes out reaches the place where it is sent, and to this end a well-nigh perfect and particularly comprehensive follow-up system is maintained at the executive and advertising offices.

The company has for some time been in receipt of communications from well-known dealers relative to the sales value of advertising campaign, but the following letter received this week from an enthusiastic dealer in Ohio furnishes an illustration of the influence of present day Columbia advertising:

"For some time past we have been getting your advertising and must say that it is very convincing. But why we have been getting it is a mystery to us, as we are not Columbia dealers but ——— dealers. But as I say above, your advertising is convincing and we are writing you with a view to putting in a stock of your records. Now you have another dealer or perhaps two in this city and you may not care to consider us. But if you do, send us your complete record list and discount by return mail. Kindly let us hear from you by return mail, and, if you can't consider us, let us have a reply to our letter any way."

INCREASE YOUR RECORD SALES

BY PLACING THIS HANDSOME FLEXIBLE COVER IN THE HANDS OF YOUR PATRONS

This attractive flexible cover is designed to hold the Victor or Columbia semi-annual record catalog, and is bound in mahogany colored imitation leather, and lined with black silk cloth. The price of this flexible cover is so low that it permits you to give same free to your customers with the record catalog inclosed, thereby making a useful souvenir and a permanent advertisement; or you may charge a nominal sum for it if you desire. In lots of 100 or more, your name will be stamped on face of cover in gilt lettering free of charge.

Send 20c. in stamps for a sample cover, with special trade prices.

No More Scratching of Cabinets and Tables by Record Albums

Our Albums are now equipped with LEATHER COVERED RING PULLS

This ring pull, which matches the album in color, makes the handling of the book easier than with the plain leather pull, and has all the practical advantages of the metal ring. This ring pull being leather covered cannot mar or scratch the highest polished cabinet or table.

NEW YORK ALBUM & CARD CO., Inc.

23-25 Lispenard Street New York
(Formerly New York Post Card Album Mfg. Co.)



GETTING RESULTS WITH "SERVICE."

How One Salesman for Talking Machine Jobber Got Business Away from a Competitor by Keeping Quiet and Helping Out in the Pinches—A Lesson in Business Building.

The man who serves is the man who wins, and this is a point well worthy of consideration by jobbers and dealers alike. Service is the key that unlocks the interest of patrons, wins their custom and enduring fidelity to an establishment. This point of view was well elaborated on by the Victor Co. some time since in the following pertinent preaching:

"Don't think I'm sore, for I'm not. I'm only curious. Our goods are the equal of So-and-So's. Our prices are right. Our deliveries are prompt. I know, too, that you are a friend of mine and want to treat me right. Now what gets me is how you ever happened to swing your recent orders over to So-and-So. Do you mind telling me?"

Thus spoke a salesman recently while sitting in the office of a manager who makes large purchases. In this, and in the rest of the story the Victor dealer should take a keen interest. Just imagine yourself in the place of the salesman and a good customer of yours in the place of the manager.

"The manager hesitated a moment, then he said:

"I believe you are broad-minded enough to hear the truth. So here it is. Yes, all you say about your goods and deliveries and our friendship is true. You have come to me in the past and sat here as you are doing now, and secured orders. But we are all learning all the time. And I have learned from this incident something vital about salesmanship which had never occurred to me before.

"Take this fellow So-and-So. He came on the scene while you were spending your time talking me into buying your goods. I will be frank with you and say that I hardly gave a thought to his existence at first. He didn't bother me at all. Just stayed around with my men—going out with them on their jobs—telling them little things, you know, and taking off his coat when occasion offered to help them out. Never saying anything about selling goods, mind you. Just *helping*. Next thing they knew my men were leaning on him. Were wishing he was around when they got stuck in some little detail or other. And he had a pat way of turning up at just such times, but never saying much. An unpretentious chap. Only happy, it seemed, when he could be tinkering with something—finding a better way to do a thing.

"That's enough of the manager's story—comes pretty close home, doesn't it?

"Now, then—how much effort do you really expend in helping your customers to get more joy out of the Victor you sold them? Don't, for goodness sake, get the notion that because you have sold 'em a machine that that's the end of it. The more those people enjoy the Victor, the more Victors will you sell to others. Here's an idea: The country is crazy, just plain crazy, right now over the tango and hesitation waltz, and the trot. To

be sure, they are not danced so very much in the ballrooms of the country, but they are being danced in thousands upon thousands of private homes, and that's vastly better business for you. On state occasions an orchestra is used—when a little coterie of friends get together evenings to dance, the Victor is the ideal thing. That's no joke. There are very real, very definite reasons for it, which were set forth last month.

"Now then, why not send a little note to the leaders of your smart set, suggesting that you'll be very glad to send a Victor and a demonstrator 'whenever miladi would like to give a little "thé dansant" "tango tea" to her friends.' That's helping people to get more joy out of the Victor, or helping more people get joy out of the Victor, as the case may be—and incidentally that sort of thing can make all the difference between a big success and a partial one."

COLUMBIA WITH KRANICH & BACH.

Famous Piano House in Harlem Secures the Representation of the Columbia Line—Will Be Featured and Exploited in a Progressive Way—Constructing Attractive Booths.

One of the most important deals consummated in some time was that made by the Columbia Graphophone Co. last month, whereby the retail store of Kranich & Bach, the prominent piano house of New York City, will handle a complete line of Columbia machines and records. This store, which is located on West 125th street, in the heart of the Harlem shopping district, is one of the most attractive piano establishments in that vicinity, catering to a high-grade clientele.

Approximately one-half of this spacious store will be devoted to Columbia products, a number of sound-proof demonstration rooms having been constructed for the accommodation of Columbia patrons, and a refined scheme of decoration characterizes the entire department. H. W. Acton, formerly connected with the Columbia retail department, is in charge of the Columbia department at Kranich & Bach.

Kranich & Bach, whose factory and executive offices are located at 237 East Twenty-third street, New York, is one of the best-known and oldest established piano houses in the industry. Their instruments are considered among the highest-grade pianos and player-pianos manufactured, and the firm sells its products through the leading dealers throughout the country.

FEBRUARY A RECORD MONTH.

"February was a splendid month, exceeding all our expectations," remarked A. W. Toennies, of the Eclipse Phonograph Co., 203 Washington street, Hoboken, N. J., Edison disc and cylinder jobbers exclusively. "Both in machines and records our disc sales have been excellent, and our dealers are all well pleased with the newspaper advertising that Thomas A. Edison, Inc., has been using, with the names of the dealers prominently displayed.

"Shipments of disc records are being received

from the factory more promptly than ever before, and disc dealers state that all the records in the disc library are meeting with a ready sale."

STRONG EDISON AD CAMPAIGN.

Persistent and Attractive Publicity in Behalf of New Disc Phonographs and Records Getting Results Throughout the Country.

Thomas A. Edison, Inc., is continuing its splendid newspaper campaign on behalf of the new Edison disc phonographs and records. These advertisements, which are designed along somewhat different lines than the average talking machine newspaper ads, are producing excellent results for the dealers mentioned in the copy, and many of the Edison disc representatives are enthusiastic in their reports of the inquiries which are being received from the individual advertisements. The present newspaper campaign is based along invitation lines rather than any attempt at direct sales. No prices are mentioned, but an invitation is extended to the public to visit any of the dealers listed on the lower part of the advertisement to hear the new Edison disc phonograph and records.

The list of Edison disc representatives presented in the latest advertisements is an imposing one, and in addition to the large number already mentioned in the columns of *The World* include the following new ones: Schultz Novelty & Sporting Goods Co., 118 Nassau street, New York; Spector & Son, 904 Prospect avenue, New York; Richard W. Olsen & Co., 617a Fifth avenue and 113 Flatbush avenue, Brooklyn; B. Poehland, 1592 Broadway, Brooklyn; Fred H. Ponty, Port Chester, N. Y.; Edward Waters, Oyster Bay, N. Y.; Hugo Traeger, 61 Wright street, Stapleton, S. I., N. Y.; William Ricker, 658 Newark avenue, Jersey City, N. J.; W. K. Muchmore, Morristown, N. J.; W. H. Morehead, 141 Main street, Somerville, N. J.; J. V. Flynn, Haverstraw, N. Y.; Rockland Talking Machine Co., Spring Valley, N. Y.; W. H. Pine, Asbury Park, N. J.; Estate of William Wright, Dover, N. J.; Gerber & Rau, Lakewood, N. J.; E. F. Glover, Plainfield, N. J.; The Jigger Shop, Princeton, N. J.; James McCollum, Rahway, N. J.; Frank C. Dobert, Rutherford, N. J.; C. F. Wolf & Bros., Somerville, N. J.; Stoll Blank Book & Stationery Co., Trenton, N. J.; Henry Bishop, Babylon, L. I., N. Y.; Benj. Rosen, Southampton, N. Y.; I. P. Hallock, Greenport, L. I., N. Y., and G. R. Pattison, West 125th street, New York. Mr. Hallock is one of the best known "talker" dealers on Long Island, catering to an extensive clientele, while Mr. Pattison but recently purchased the Harlem store of the Hallet & Davis Co., the prominent piano house.

PRESIDENT EASTON RETURNS.

Edward D. Easton, president of the Columbia Graphophone Co., accompanied by Mrs. Easton, returned to New York Thursday equipped with renewed energy and vigor after a short vacation to Bermuda.

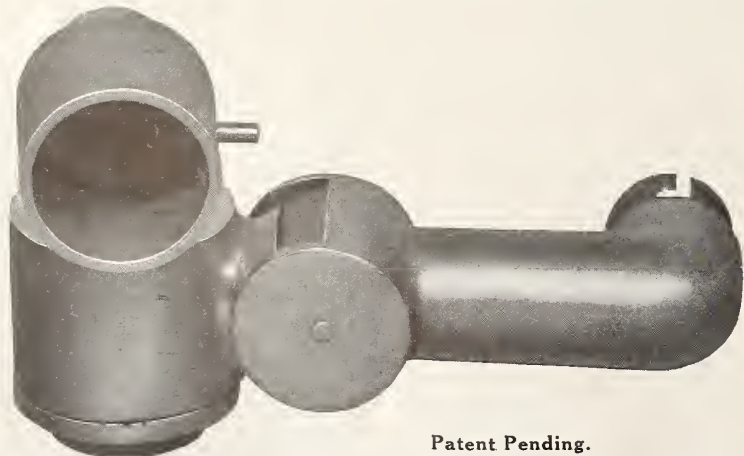
IMPORTANT NOTICE TO EDISON DISC DEALERS

The New Thomas Attachment

Plays lateral cut records on the new Edison Disc Machine. It has a patented ball bearing joint, which makes it work flexible and free. You should not fail to have a quantity of these attachments in stock, as it will greatly add to your machine sales.

Write to your jobber for a sample,
if he hasn't it write to us.

F. H. Thomas Co., 689 Boylston St., Boston, Mass.

FROM OUR EUROPEAN HEADQUARTERS

2 GRESHAM BUILDING, BASINGHALL STREET E. C., LONDON, W. LIONEL STURDY, MANAGER.

Flood of Cheap Disc Records Causing Noticeable Reaction in Trade Circles—First Case of Record Infringement of Copyright in Court—Trade in Persia and Japan—The Edison Disc Line in England—Improvement Looked for in Reproduction—Leipzig Fair Visitors—New Records Placed on Market—Dinner to Paul H. Cromelin—Latest Record Lists Interesting—General News of the Trade.

(Special to The Talking Machine World.)

LONDON, E. C., ENGLAND, March 5.—Gramophone trade conditions on this side continue to excite a certain amount of nervousness, chiefly in relation to ruling prices for disc records. There is little or no cause for complaint on the ground of actual sales, for in this respect trade is undeniably good, time of year considered, but it requires an enormous turn over in order to ensure a reasonable amount of profit under present circumstances. Things went smoothly enough during the rush-time months prior to Christmas, but now that business has settled into a gradual decline, as we approach the summer season, traders are forced to abandon the policy of drift and concentrate on putting their house in order, if it is not already too late. In some cases this tardy realization of their serious position tends but to heighten the general instability prevalent in trade circles, and it will require more than ordinary commercial genius to find a successful solution of present difficulties. Time has revealed in no uncertain manner the futility of the policy which actuated the issuance of cheap records. The object aimed at may yet be achieved to some extent in the near future, indeed, if I read certain signs correctly, we shall experience more than one withdrawal from this market before next season. Competition will, however, be as strong as ever, for this field of activity seems invested with an attractiveness as fatal as a light is to a moth. Gramophone merchants come and go, and notwithstanding the obvious peculiarities of trade conditions here, we never lack the bright and hopeful "prospectors" who, somehow deceive themselves into the belief that they will revolutionize things and achieve success, where others of experience have failed. But that, by the way, whether or not competition becomes less active or otherwise, the fact remains that nothing can undo the irreparable damage sustained by the gramophone industry as the result of these cheap record issues. Indeed, I do not hesitate to state plainly that it is responsible for a substantial setback in the commercial development of sound trade, and the future alone can reveal the full extent of this damaging policy. A very undesirable class of trader has sprung into existence, price-cutting is more rampant than ever, decent dealers find it increasingly difficult to trade profitably, and the sales of records at half-a-crown are considerably on the decline. These are the apparent facts from a superficial survey of the situation, and I think it will be generally admitted they are bad enough. Optimism is for the time being under a cloud. The shilling records flourish as strongly as ever, and it is certain that if manufacturers do not withdraw this unsound trading, time itself will eventually compel them to, by reason of financial loss. The new policy of the Columbia Co. in introducing an eighteen-penny record, reduction of the Gramavox record to the same level, and as reported elsewhere the reduction of the Favorite record from a half-a-crown to eighteen pence, accompanied by the statement that the records will be marketed through an agency, is not without great significance in the light of present conditions. A large public has sprung into existence for the sale of medium-priced discs, and it is in keeping with the times that these firms should now cater for this extensive demand.

There are rumors that the Zonophone Co. would embark upon a new campaign, but in response to my inquiry direct, I am informed that it is mere

idle speculation—in short, the present policy of the company remains unchanged.

New Policy of the Favorite Company.

Under date of February 18, T. D. Addis, manager of the London depot of the Favorite Record Co., has intimated by circulars that "arrangements are now being made under which the English business * * * will be carried on through an agency." Pending completion of the proposed new arrangement, Mr. Addis will personally attend to all matters. Full particulars of a generous exchange scheme operative until the end of February, accompanied this circular, which also advised the trade that the price of Favorite records was now: Ten-inch, 1/6; twelve-inch, 2/6, retail. A revision of the trade terms, presumably comes into force simultaneously with this reduction.

I do not think there is any need to enlarge upon the importance of this drastic change of policy, beyond a mention of the fact that it has met with general approval, among dealers especially. The view exists, however, in more than one quarter, that the company should have taken this very necessary step several months ago, but, better late than never, it is meeting with all the success that may be expected of a high quality record at such a competitive price as eighteen pence. If price and quality determine sales, I can only say that the Favorite record is assured of unlimited popularity among the great army of gramophonists.

First Record Infringement of Copyright.

A most important case in the history of the gramophone trade came to light recently in the Tower Bridge Police Court. From the proceedings reported below, it will be seen that this is the first case of infringement under the Copyright Act, and it is particularly suggestive in relation to the position of dealers who, perhaps, unknowingly place such records on sale. The records may have been published in all good faith without a copyright stamp. I am not speaking of the present case—and trusting in the action of the record publishing house, the dealer is liable to find himself in a very awkward plight. There is, I think, little occasion, however, for the respectable retailing houses to anticipate trouble in this direction. If a recorded copyright composition is sent out unstamped by the manufacturer, I am open to say it is not so much his fault as that of the Act itself, which is a source of continual complication by reason of its all too-parliamentary phraseology, and the fact that it places upon the issuing house the onus of elucidating obscure and sometimes questionable copy-

right ownership claims. Notwithstanding, or rather perhaps because of this condition of things, it is a tribute to the thorough and careful manner of investigation of copyright ownership made by record manufacturers that the case in point is the first known, and withal an isolated one during close upon two years' operation of the Copyright Act! I do not seek to minimize the gravity of it. With so many cheap, and job lots of records on the market, there is an ever-present possibility of trouble for the dealer who buys indiscriminately. The law cannot recognize any plea of ignorance, and it behooves all buyers of records to exercise unusual precaution in buying under such circumstances as is revealed in the following case, as reported by the London Music Trade Review. The summons was taken out by the Mechanical Copyright Licenses Co., Ltd., against Adolf Knopf, of 62 Lower Marsh, Lambeth. Counsel stated that his clients, the plaintiffs, attached considerable importance to the case. He believed it was the first action for unlawful infringement of copyright under the act of 1911. The prosecutors were the duly authorized agents of Herbert Sullivan, who on the death of Sir Arthur Sullivan, became entitled to the benefits of his compositions. The defendant appeared to have two places of business—one at 25 Waterloo road, and another at 62 Lower Marsh. The five summonses were in respect of various dates in January, when representatives of the company paid visits to the two places of business and purchased gramophone records of "The Lost Chord" and a song from "The Gondoliers." The defendant, in selling these records without a stamp, knew that he was doing wrong; he had been in the employ of a company of high standing, and was now an agent for the same company. Counsel added that he proposed to ask for an order for the destruction of the records on the premises.

Mr. Benwell, for defendant, said his client was in Russia. What he (Mr. Benwell) was told was that about a month or six weeks ago the defendant purchased about 12,000 gramophone records, some of which were stamped and some unstamped. As to some of these records, the copyright had become extinct, and the vendors gave his client an indemnity. He was willing to give an undertaking to pay all royalties which might be due. An offer to do so had been given before proceedings were undertaken. Huntly Jenkins observed that an undertaking was of little value.

The magistrate, in imposing a penalty of 40s on each summons, with five guineas costs, directed that the records in question should be destroyed.

Persian Trade Conditions.

Two consular reports just issued on the trade of Ispahan and Bushire, simply reiterate what has been stated so often about the anarchic conditions of Persia. Neither life nor property is safe, and the prevalent insecurity makes trading well-nigh impossible. An instance is given where specie was sent to a town in southern Persia, the distance being 260 miles. It reached its destination ten months later! Under these conditions trading is much too hazardous, and at such risks it is only possible for those who charge very high prices in order to cover the all too frequent losses.

No Annual Report Yet Ready.

According to a German contemporary, the directors of Carl Lindstrom, A.G., Berlin, declare that no definite announcement can yet be made about the past year's dividends owing to the fact that it will depend upon the reports of their foreign companies. The dividend is expected to be not less than 15 per cent., but this will be announced at the General Board meeting to be held about the middle of this month.

According to a report from Germany, the Deutsche Gramophon Co. are taking steps to enforce their claim to the exclusive use of the word gramophone as applied to instruments and

(Continued on page 44.)



STROH VIOLS

VIOLIN, VIOLA, ETC.

The mellow and matured tone of these instruments, which are constructed largely of aluminum, yet possess none of the characteristics of the gramophone or wind instrument, is only one of its many points which are fully set out in an illustrated booklet which will be mailed free on request to the sole makers.

String Fiddle

GEO. EVANS & CO.

94 Albany St.
London, Eng.

OR

in U. S. A. to their sole representatives

OLIVER DITSON Co.

150 Tremont Street
BOSTON

NEW YORK and PHILADELPHIA



Violin

FROM OUR LONDON HEADQUARTERS—(Continued from page 43).

records. The German trade press seem to resent this, claiming that the word is a generic term, as in England.

Increasing Demand for Music from Japan.

The recently published particulars of export trade with Japan indicates that with the Japanese European music is becoming increasingly popular. The 1910 figures show that Great Britain exported to that country instruments and records to the value of only £340, but two years later, 1912, we find that the figures have risen to the extraordinary total of over £5,000, notwithstanding the active operations of new record factories in Japan. The German export figures for the years mentioned were £2,325 and £10,210 respectively.

Double Sided Records Most Popular.

There is no question of the popularity of double-sided records as against the single-faced in the United Kingdom, despite the difficulty of mating two titles acceptable to the buyer. In Germany, however, it has been a subject of question, and representations for a return to the single-faced records have been notified. To test the matter, the Deutsche Gramophon Co. intend to issue identical titles on both kinds of discs. Some permanent policy will result if it is shown that there representations are based on the proved requirements of the market. The verdict will be awaited with keen interest.

New Columbia "Regal" Record.

The Columbia Graphophone Co. have now entered the field with another new record—ten-inch double-sided, styled the "Regal," at eighteen pence retail. The official news reached me just in time to miss the mail for last month's issue. The announcement has caused much comment throughout the trade.

In announcing the "Regal," the company says (in part): "It is generally acknowledged in the trade that during the past twelve months the immense number of cheap machines and records sold has created an entirely new buying public for records.

"This new public, accustomed to a low price for records, at the same time realizes that it cannot expect on the cheapest records artists of acknowledged fame, and would therefore willingly pay a few pence more for artists whom it is not possible to give on cheap records. * * * The Regal catalog consists of 457 records transferred from the famous Columbia-Rena records, and fifty-five records of new recordings. * * * Regal records will be sold under strict price maintenance covered by our patents. Supplements will be issued monthly. * * * The name 'Regal' is well known in the trade in connection with the famous Regal instruments." A few of the well-known artists in the Regal catalog are: John Bardsley, Robert Howe, Jones and Van Brunt, Collins and Harlan, I. Gillette, Bela Berkes Orchestra, Austin, Kitchen, Beth Tate, May Moore Duprez, Loriner, Cunliffe, Sheridan, Will Evans, Champion, Jack Mills and company.

In connection with the "Regal" record issue, the titles deleted from the Columbia catalog are exchangeable on the basis of an order for twice the value in Columbia-Rena records, or three times the value in Regal records. The exchange ended February 14, and only new records were accepted.

Marketing the Edison Disc Line in England.

Considerable interest is evinced this side by an authoritative statement from Orange concerning the marketing of the Edison disc products in England. The news was conveyed by letter from the Edison Co. to a Glasgow correspondent, and in part is as follows: "Mr. Edison has issued strict instructions that no disc goods are to be exported until the large initial demand in the States has first been satisfied. * * * The records are practically unbreakable. * * * We are not supplying a change device so that our records may be played on other machines." Apparently it is the company's intention to develop an entirely new field when they are ready to market the product here, but somehow or other the impression exists that we are not likely to see much of the Edison disc for some considerable time

ahead. We shall most certainly await its advent in England with great interest.

Farewell Dinner to Paul H. Cromelin.

No better proof of the good fellowship that exists amongst members of the trade could be found than the complimentary dinner which was given to Paul H. Cromelin recently at the Connaught rooms by the Kinematograph Manufacturers' Association as a farewell following his retirement from the service of the Edison Manufacturing Co. after three years in England.

The feature of the evening was the presentation to Mr. Cromelin of a "All British" Old Spade Guinea from the members of the association, which was followed by the passing around of the loving cup with all due formality.

The chair was occupied by H. A. Browne in the absence of the official chairman of the association, J. F. Brocklis. Telegrams of regret were read from Messrs. A. Reed, H. Paulson, G. H. Smith and H. Hayman. Will Jury proposed the first toasts of the evening, namely, "Our Guest," and referred at length in most complimentary terms to Mr. Cromelin's connection with the trade and his fairness in all matters of business. The toast was supported by Messrs. Will Barker and H. A. Spoor, to all of which Mr. Cromelin replied with much feeling, especially when speaking of the kind treatment he had received at the hands of his British associates and competitors. A toast to "The Chairman" and the response by Mr. Browne brought the evening to a happy close.

Thorpe Bates' First Columbia Records.

In announcing the first records by Thorpe Bates, the Columbia Co. states that it considers them the finest examples of baritone recording yet issued. Thorpe Bates is one of the best known concert artists of the day, and he has built a reputation of strength upon the rich qualities of his voice and his own artistic versatility.

Thorpe Bates is represented by two records as his first Columbia contribution—a 10-inch record of "Youth" and "To Anthea" and a 12-inch record of Amy Woodforde-Finden's lovely song, "O



To T.M. the King and Queen of Spain



To H.M. the King of Sweden



To H.H. the Khedive of Egypt



To H.M. the King of Italy



To H.M. the Shah of Persia



By Appointment To H.M. Queen Alexandra

"His Master's Voice"

—the trade-mark that is recognised throughout the world as the

Hall-mark of Quality

AUSTRIA: Oesterr. Gramophon-Gesellschaft, m. b. H., 8, Krugerstrasse, Vienna.
 BELGIUM: Cie. Française du Gramophone, 51, Avenue de la Porte de Hal, Brussels.
 DENMARK: Skandinavisk Gramophon-Aktieselskab, Frihavnen, Copenhagen.
 FRANCE: Cie. Française du Gramophone, 115 Boulevard Richard Lenoir, Place de la République, Paris.
 GERMANY: Deutsche Gramophon-Aktiengesellschaft, 35, Ritterstrasse, Berlin, S42.
 HOLLAND: American Import Co., 22a, Amsterd. Veerkade, The Hague.
 HUNGARY: The Gramophone Co., Ltd., IV, Kossuth Lajos-Utca 8, Budapest.
 SPAIN: Cia. Francesa del Gramophone, 56, Balmes, Barcelona.
 SWEDEN: Skandinaviska Gramphon-Aktiebolaget, 52, Appelbergsgatan, Stockholm.

RUSSIA: The Gramophone Co., Ltd., 45, Nevsky Prospect, St. Petersburg; 9, Golovinsky Prospect, Tiflis; 30, Novia Svit, Warsaw.
 EGYPT: The Gramophone Co., Ltd., 13, Rue Stamboul, Alexandria; Rue Moussy, Cairo.
 EAST AFRICA: Bayley & Co., 8 Beira, Lourenço Marques.
 SOUTH AFRICA: Darter & Sons, Adderley St., Cape Town; Mackay Bros., Rissik Street, Johannesburg; Mackay Bros & McMahon, 443, West Street, Durban; Ivan H. Haarburger, Maitland St., Bloemfontein.
 INDIA: The Gramophone Co., Ltd., 139, Balliaghatta Road, Calcutta; 7, Bell Lane, Fort, Bombay.
 AUSTRALIA: The Gramophone Co., Ltd., Hoffnungs Chambers, Pitt Street, Sydney.
 GREAT BRITAIN: The Gramophone Co., Ltd., 21, City Road, London, E.C.



Great Britain:

The Gramophone Company Ltd
 21 City Road London EC

FROM OUR LONDON HEADQUARTERS—(Continued from page 44).

Flower of All the World," paired with the favorite ballad "Sincerity."

Latest Improvement in Reproducing.

It is, I think, generally admitted that under present methods we must look for gramophone improvement, not so much from the side of recording as of reproduction. I would not suggest that inventors have exhausted all efforts in the former direction, but the fact remains that greater attention seems to be devoted to the methods of reproducing sound, as witness the progress made within recent years by not a few of our leading concerns. Mechanical music is thought by many to have reached a stage little short of perfection, and certainly it is a marvelous thing to have produced from an inanimate black disc a sweet discourse of melodious sounds. Still, one cannot disguise that scope exists for improvement, and the man that can "show the way" to this end, will be a maker of history. Possessing a full measure of enthusiasm, without which it would perhaps be difficult to get a commercial hearing, the sponsors of new inventions often develop the idea of revolutionizing the trade, seldom for any purpose, unfortunately. There is always a welcome for "something better," and it can only possess the elements of success providing it fulfils all claims, is well supported financially and is marketed in an enterprising and energetic manner. These attributes I can partly vouch for in connection with a new kind of method for the reproduction of sound which is about to be introduced on this market. The inventor is Jose Hoffay, whose extensive experience with the American Columbia Co. at once invests his claims with all the weight of a man who "knows!" Your correspondent was recently accorded the privilege of a first confidential demonstration of Mr. Hoffay's new instrument, a description of which must be left until another time when it is ready for the market. At the moment I can but speak of its tonal qualities. Every kind of record was played—Columbia, H. M. V., new Edison disc, Marathon, etc., vocal and instrumental. I can frankly say the result was truly astonishing, all being reproduced with remarkable fidelity; in fact, in a more realistic manner than is possible on the ordinary instruments in use to-day. Somehow or other the volume of even the loudest records, bands, etc., seemed just right, as did also that of the lighter class of instruments. One or two experts who have heard Mr. Hoffay's machine declare its superiority over all other sound reproducing mediums and predict that it will meet with instantaneous success. Certainly I have never heard records reproduced in such a natural and musically perfect way. It is, in my opinion, the most important development in the history of this trade, and we shall await complete details of its construction with keen interest. The new instrument is covered by nine separate patents and is protected in all the leading countries of the world. It is a gramophone and yet, says Mr. Hoffay, so vastly superior in its beautiful results that he hesitates to use the word. For a suitable commercial name Mr. Hoffay therefore authorizes me to state that he will award a prize of £10. Communication to our London office will be duly forwarded to the right quarter.

Gramophone Co.'s Records for March.

A list of more than special merit is that issued by the Gramophone Co. for March; it is brimful of interest for the music lover, whose every mood is ministered unto with a range of titles of great variety. The Celebrity records include a gem in "Dreams of Long Ago," sung in English by Signor Caruso, and "Marechiaro" (Tosti), by the great Titta Ruffo. Miss Alma Gluck sings two little ballads. Miss Ruth Vincent, we observe, is down for "A Birthday" (Cowen), and the lady tenor, Miss Ruby Helder, the "Green Isle of Erin." Some idea of the quality offered this month by the H. M. V. company may be gained by a perusal of the complete list of titles as follows: Twelve-inch, double-sided—"Welsh Rhapsody" (German), and "Norwegischer Kunstler Carnival" (J. S. Svendsen), Bournemouth Municipal Orchestra; "The Land of Roses," Valse (Herman Finck), "Ecstasy Valse" (Sidney Baynes), Mayfair Orchestra; "A Dream of Egypt," "Introduction," "Beside the Lonely

Hill" and "I Envy Every Circlet" (A. Woodford Finden), band of H. M. Coldstream Guards; "Maximilian Robespierre op. 55, Part I and Part II (H. Litloff), band of H. M. Coldstream Guards; "Marana Tango" (Nat. B. Ayer), and "Seduction Tango" (G. Noceti), Le Petit Cafe Orchestra. Ten-inch, double-sided—"Jumping Jim" (C. Kat-taum), and "Devil-May-Care," two-step (Paul Lincke), Mayfair Orchestra.

Twelve-inch, single-sided—"Parsifal"—Verwandlungsmusik Part 1, Act 2 (Wagner: "Parsifal"—Verwandlungsmusik Part 2, Act 1 (Wagner); "Parsifal"—Verwandlungsmusik, Act 3 (Wagner), all by Berlin Philharmonic Orchestra; "Some of These Days" (Shelton Brookes), Miss Shirley Kellog; "Katzensfuge" (Domenico Scarlatti), Mark Hambourg (piano); "Hush-a-Bye Baby" (Archie Naish), Tom Clare; "The Fallen Star" (Chevalier), Albert Chevalier; "The Village Fire Brigade" (monologue), Alfred Lester (assisted by Miss Buena Bent; "Take Advice from One Who Knows" (Arthurs and David), Miss Jenny Benson; "How Are Ye?" (Judge and Williams), George Graves.

Ten-inch, single-sided—"All Soul's Day" (Richard Strauss), John Harrison; "The Vagabond" (Molloy), Thorpe Bates; "Offerings" (Monk Gould), Hubert Eisdell; "Down in Lover's Lane" (Easthope Martin), Miss Paolo St. Clair; "Irish Names" (Turvey), Reinald Werrenroth; "The Maiden in Gray" (Barnicott), Elsie Baker and Frederick Wheeler; "Soldier, What of the Night?" (Airlie Dix), Robert Radford; "I Have a Thrush at Eve" (Codman), John McCormack; "Narcissus" (from water scenes) (Nevin), Florence Quartet; "Serenata" (Moszkowski), Miss Maud Powel (violin); "I Want to Be in Dixie" (Berlin and Snyder), Willie Solar.

Leipzig Fair Visitors.

An unusually large number of gramophone men will be making their way to Leipzig for the opening of the fair on March 2. The majority will be away for five or six days. From all reports there is a promise of some especially interesting exhibits, and these I hope to deal with in my notes next month. A fairly close canvass of the trade reveals the following list of names which will doubtless be inscribed upon the fair register: S. W. Dixon, the Gramophone Co.; John A. B. Cromelin, European general manager; Louis S. Sterling, British manager; G. L. Funnell, factory manager, and E. M. Burns, New York export manager, all of the Columbia Graphophone Co. Christian Durve, Manchester; T. Llewellyn Davies, Wholesale Musical Supply Co.; George and Bernard Andres, Homophone; A. N. Gray and W. Denville Simons, National Gramophone Co.; A. Balcombe and E. Somerfeld, O. Ruhl, Ltd.; A. Hertzog and G. Ficker, New Polyphon Supply Co.; E. Oppenheim and F. Cassel, Scrutton street; G. Murdock and R. Fulton, John G. Murdock & Co.; W. Cooper, Coliseum Record Co.; W. Johnson, Liverpool; Frank and Edgar Samuel, Barnett Samuel & Sons, Ltd.; H. Bosman, Scala Record Co.; Messrs. M. S. J. and B. Woolf, M. & A. Woolf, Ltd.; Messrs. Nottingham, Anchor Record Co.; C. F. Harth, Syrena Record Co.; W. H. Reynolds, W. H. Reynolds Ltd.; P. Cowan, Alexander Record Co.; H. Lewin, Operaphone Record Co., exhibit, Peterstr. 26; José Hoffay, and N. Carlton, late of the London Record Co.

In addition to the foregoing the following are probable visitors, but at the time of my inquiry they were a little uncertain: W. Mauson, British Zonophone Co.; L. H. Kempe, National Gramophone Co.; Mr. Appleton, Leids, and T. D. Addis, Favorite Record Co.

Trade Commissioners on Visit.

In accordance with the practise that has been established for his Majesty's Trade Commissioners in the several Dominions to visit this country officially from time to time, so that manufacturers may have the opportunity of consulting them on any matters connected with their business, or of obtaining information as to the possibilities of extending their trade, it has been arranged that the Trade Commissioner for New Zealand (W. G. Wickham) shall come to this country, and will

doubtless have arrived by the time these lines appear in print. Representatives of firms will first be seen in London, and then trade and industrial centers in the provinces will be visited.

First Gorilla Records.

Colonel "Buffalo" Jones, the veteran hunter of the Wild West, who has spent his life facing every kind of wild animal, with no other weapon save his lasso, is in London preparing for an expedition to rope gorillas in the French Congo. The Buffalo Jones expedition is taking a graphophone with it, according to the Daily Mail, to obtain the first "voice-records" of these terrible animals, whose roar is described by those who have heard it as being terrific—far louder than that of the lion.

The Efficient Salesman.

In the course of a business chat with young men at a London hall recently, F. W. Moore said: "Salesmen of all ranks from the peddlers on Ludgate Hill to the diplomatists at the courts of Europe, render service to their employers, to their customers and to themselves, and no deal can be straight and clean unless the interests of all three classes are properly guarded." The efficient salesman was the man who studied his goods, his customers and himself. He must make a hobby of his work, always learning from his failures how to avoid a repetition of them in his strenuous game, and he must have nerve, courage and grit, together with loyalty to his employer. He must be physically fit in order to be mentally fit, and must be candid."

New Companies Incorporated.

Ebonitis, Ltd., manufacturers of plastic material for making gramophone records; capital, £10,000; office, 5 Willowbrook Grove, Camberwell, London, S.E. In addition to the manufacture of records, the articles of association provide for the manufacture of electrical switches and other goods. The secretary pro tem. is W. F. Robbins.

New Disc Record Placed on Market.

Yet another new disc has been placed on the British market. It is called the Syrena grand record, ten-inch double-sided, and is the product of a large Russian firm whose operations, we learn, are very extensive on the Continent and abroad in other directions. Additional interest is aroused in the new venture on account of the fact that its control is placed in the hands of C. F. Harth, whose experience with O. Ruhl, Ltd., and more recently as London manager of the Favorite Record Co., may be accepted as a valuable asset in the launching of the "Syrena Grand" on this market. In partnership with Mr. Harth is Mr. A. Dub, who comes from the company's Warsaw headquarters, where, of course, he gained great experience of talking machine trade in general. A linguist of no mean ability, Mr. Dub speaks English fluently, and he will of a surety soon become a leading personality in British trade circles. These gentlemen have opened offices at 56 City road, London, where they trade under the title of Messrs. C. F. Harth & A. Dub. In conversation with your correspondent the former gentleman said: "The Syrena Grand repertory includes practically all the best Jewish, Russian and Polish titles, and there exists already a fairly comprehensive list of English compositions. We intend to concentrate on increasing the latter as soon as may be possible, and we shall offer the British trade a substantially good record at a competitive price. We are not confined to the United Kingdom, and shall cultivate trade, especially with the British colonies and dependencies." Under test I found the Syrena Grand a record of pleasing qualities in all respects, and there seems every prospect of its success, given, as I am assured will be the case, an energetic policy and an increased repertoire of English titles. Both gentlemen have The World's best wishes for the complete success of the new venture.

The March Columbia Supplement.

The March Columbia supplement in its new colors affords the trade a magnificent opportunity to boom the popular Columbia-Rena series. It is a

(Continued on page 46.)



Nine out of ten people who hear record A-1448, "A Little Love, A Little Kiss" (instrumental)—buy it. A 65c. Columbia Double-Disc Record.



(Write for "Music Money," a book "full of meat" for those dealers interested in quick and frequent turnover of capital.)

Columbia Graphophone Company
Woolworth Building, New York

FROM OUR LONDON HEADQUARTERS—(Continued from page 45).

well-known truism that nothing increases public interest in any goods more than the presentation of those goods in a new form, and there will be few record buyers who will fail to be highly impressed with the new style Columbia supplement. An important reason why this handsome booklet should be well distributed by dealers is that it contains the month's new issues of Columbia "De Luxe" records, a feature which will stimulate a demand for Celebrity records with all dealers.

Reed Miller is one of the artists represented by a twelve-inch Columbia-Rena record this month, being heard in the tenor aria "When Other Lips," or, as it is equally well known, "Then You'll Remember Me," from the "Bohemian Girl."

The instrumental section of the March Columbia supplement is unusually strong, for among twelve-inch records we have the inimitable Sergeant Leggett in fine cornet records of the Berceuse de "Jocelyn" and Schubert's Serenade, while in ten-inch there is that other artist of the cornet, Arthur Laycock, in "Old Folks at Home" and "Robin Adair"—both with variations. In addition, there are pianoforte solos, instrumental trios and a brace of merry concertina solos—"The Wedding Glide" is one of them—by Alexander Prince.

The Columbia announcement this month of a first record by the Milan Symphony Orchestra will attract general attention, especially in view of the statement that this record was made by the famous orchestra under the baton of Maestro Romani. This great Italian conductor made himself personally responsible for the orchestrations for this recording, and the orchestra of fifty performers has, under his direction, produced a record that will assuredly be acclaimed a new achievement in recording. The first record—twelve-inch, by the way—is a fantasia on themes of "La Traviata" in two parts, and a more entrancing interpretation, marked by a delicacy that is little short of wonderful in its detail and definition, it would be difficult to imagine.

The famous American prima donna, Alice Nielsen, furnishes a beautiful record in the Columbia "De Luxe" series this month of Tosti's "Goodbye" and "Sweet Genevieve."

Orville Harrold, who has been enjoying the distinction of being pitted as an attraction against Caruso in New York, has his first ten-inch record in the Columbia Celebrity series this month, being heard in two English songs—"For You Alone" and "Absent."

Ysaye—the world's master of the violin—has a new record on Columbia this month, it being that lovely tenor aria, the prize song from "The Meistersinger."

American Mails—Important Alterations.

It is announced that the British Postmaster General has relieved the Cunard Co. from collecting mails at Queenstown (Ireland) owing to the risk incurred in entering the harbor there with their large ships during violent weather. All the Cunard packet boats, including the "Lusitania" and "Mauretania," will therefore proceed direct from Liverpool to New York. In consequence it is now necessary for all correspondence intended for conveyance by these steamers to be posted on Fridays before midnight at the London General Post-office, the times of posting at other London offices and in the Provinces being similarly advanced.

The Progressive Quality of Half-Crown Records.

It is significant of trade conditions in this country that the various companies still manufacturing records at two shillings and sixpence (they—the companies—are a diminishing quantity, by the way) would seem to be concentrating upon the production of lists which each month represent a higher standard of quality over preceding issues. This is doubtless as wise a provision as it is necessary, having regard to the growing influence of records priced below this one-time standard rate. Be that as it may, it cannot detract from the recognition which is due the enterprising policy, for instance, of the Zonophone officials in catering to a select

public with records of increasingly high merit and general value each succeeding month. Space precludes a detailed mention of the various items comprising the latest supplement, but I am moved to these thoughts because of its generally superlative quality, which throughout offers a typical example of the progressive nature of present-day recording in conjunction with all that goes to the production of good records.

TO SUPERVISE DANCE RECORDS.

Mr. and Mrs. Vernon Castle Engaged by the Victor Co. to Supervise Records for Dancing.

In a letter enclosing an advance copy of new records for the month of April, the Victor Co. sent out to its trade last week an important notice to the effect that Mr. and Mrs. Vernon Castle, the prominent exponents of the modern dance, had been engaged to supervise the making of all Victor dance records. The first records produced under this supervision are included in the April list.

Mr. and Mrs. Vernon Castle have acquired a country-wide reputation for their splendid interpretation of the modern dances, and Victor dealers are afforded a valuable selling argument in this announcement by the Victor Co. that the new Victor dance records will not only meet with the approval of Mr. and Mrs. Castle but will be recorded under their direct supervision.

John Cavanaugh, the popular manager of the Edison disc department of A. I. Namm & Son, Brooklyn, N. Y., is being congratulated on the addition to his family recently of a bouncing baby boy. Mr. Cavanaugh's enthusiasm over the Edison disc line is proven by the fact that the new arrival was named Edison Cavanaugh.

Oreste Vessella, the famous bandmaster, has opened a talking machine store at 1436 Atlantic avenue, Atlantic City, N. J.

HERMANN THORENS, Ste. Croix (Switzerland)
TALKING MACHINE WORKS

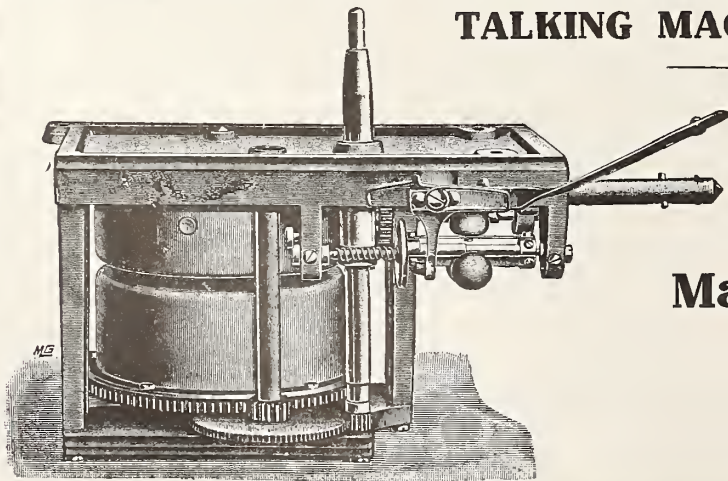

Motors and Sound Boxes a Specialty

CONCEDED TO BE THE BEST MANUFACTURED

OVER THIRTY DIFFERENT STYLES

Machines with or without Horns

FIRST QUALITY ONLY

Noiseless Motors

HIGHEST RECOMMENDATIONS

WRITE FOR DESCRIPTIVE CATALOGUE



ECLIPSE PHONOGRAPH COMPANY

A. W. TOENNIES & SON

203 Washington Street, Hoboken, N. J.

JOBBER OF

Edison Disc and Cylinder Phonographs Exclusively

Dealers of New York and New Jersey
Write for terms and discounts.



SWAMPED WITH THE DEMAND FOR RECORDS.

Volume of Record Business in Cincinnati Has Been Phenomenal—Leading Talking Machine Houses Make Most Encouraging Reports—A Policy of Expansion Is in Evidence Throughout the Trade and Everyone Is Most Optimistic.

(Special to The Talking Machine World.)

CINCINNATI, O., March 4.—During the past month the local talking machine trade has been swamped with demands on the part of record fiends. The volume of business of this class has been tremendous. The manager and assistants of the various places, while happy over the sales, would be willing to have a little rest. This is the state of affairs in Cincinnati. Even during the unusual blustery days of February, the customers found their way down town and loaded up.

The local situation, as a whole, appears very satisfactory. The arrival of the Cincinnati branch of the Phonograph Co., attracted much attention at the time, but the house is now taking its place in the ranks. Manager Peterson claims his main trouble is to secure sufficient supplies. J. B. Sims has joined the traveling forces of this branch. The company now has four local dealers. John Arnold, one of the latter, is still in the West, seeking health. Encouraging news comes from the little hustler, according to word given out at the store. Arnold is expected back about March 20.

Manager Dittrich, of the Rudolph Wurlitzer Co., said:

"Referring to the February business in our Victrola department, we can only say that the demand was practically as great as that experienced during December, not including the holiday week, and that the results were extremely gratifying, notwithstanding the great shortage of machines and records. The business has reached a basis where the supplies of instruments and records on hand determine the volume of business, and it looks as though this situation will continue indefinitely.

"The dance records have opened up a tremendous field for sales of Victrolas of all sizes, and this, together with the increasing popularity of the machines as a general entertainer, has opened new avenues which will make the business during the year 1914 grow far in advance of that of 1913.

"Applications for Victor agencies are coming in larger quantities than ever known before, and the initial orders are exceptionally large and usually include sufficient stock to guarantee the dealers being able to start from the very beginning with proper equipments for pushing the Victrola business most successfully."

"Yes," said Manager Whelen, of the local Columbia Graphophone store, "business continues good. February sales went far beyond our expectations, and every department ran ahead of any previous February in the history of the Cincinnati store. Record sales have been phenomenal and, despite the fact that we daily received large shipments of records, we ran out of certain records for which there is a great demand. The Columbia dance records have certainly filled a long-felt want

among the dance enthusiasts, and those who have tried them are unanimous in their opinion that the tempo is simply perfect, which of course is the most important feature."

When Mr. Whelen was asked about the school proposition, he was all smiles when he said: "Well, we certainly have got the schools acknowledging the desirability of Columbia instruments and records for that purpose. We have just closed with four more schools, the last sale being at the Windsor School, in competition with two other makes of instruments."

The Columbia Graphophone Co. states that it has closed with a large number of new dealers during the month of February, and the traveling men report that business is apparently good throughout the entire territory.

The Lyric's talking machine shop made a very good showing in February, according to Manager Ahaus. This, he said, was particularly true of the last week, when the big rush came.

The Victor department of the Otto Grau Piano Co. is doing very well. The company is gradually enlarging the line and expects to do quite a business this year.

Victor business continued at high tide all during the past month at Aeolian Hall. The exceptional showing of December and January were maintained; in fact the only complaint was about the difficulty of securing goods—both machines and records.

The Aeolian Victrola department is unquestionably most efficient, and well equipped in every way. The record service especially has been developed to a high point. All styles of machines went big indeed; it was largely a case of customers accepting any styles that could be gotten, as the shortage on some styles was keenly felt throughout the month.

The demand in records ran mainly to dance music, of which it was impossible to secure enough stock. The lists of special dance records scored a pronounced hit. The European one-steps and tangos scored heavily. Prospects at Aeolian Hall are for a continuance of boom business. The company continues to advertise Victrolas heavily.

BIG AUSTRALIAN SHIPMENTS

Of 240,476 Blue Amberol Records Within a Period of Six Weeks.

That Australians appreciate phonograph music is more and more evidenced every day. "The Star of India" recently sailed with one order alone for 140,476 Blue Amberol records. Another shipment of 100,000 has just been made by Thos. A. Edison, Inc., making 240,476 in the space of six weeks. And this is the dull or summer season in Australia, too.

SETTLED IN NEW QUARTERS.

The Schmelzer Arms Co., Talking Machine Jobber, Occupies Handsome New Home.

(Special to The Talking Machine World.)

KANSAS CITY, Mo., March 5.—The Schmelzer Arms Co., the prominent jobbers of Victor talking machines and Edison phonographs in this city, is now settled in its handsome new building at 1214-1218 Grand avenue, between Twelfth and Thirteenth streets. The new building, especially designed under the direction of the company for the purpose of housing the various departments of its business, which includes the handling of an extensive stock of sporting goods, is of concrete throughout, with an elaborate tile front, and contains approximately 57,500 square feet of floor space.

NEW COLUMBIA AGENCIES.

Some Important Deals Made Recently in Connection with the Booking of New Representatives for the Columbia Line—Some Recent Additions to the Rapidly Growing List.

The Columbia Graphophone Co. has closed a number of important deals during the past fortnight which illustrate the rapid strides in popularity that Columbia products are making throughout the country. These new representatives, who are all located in near-by territory, form but a very small percentage of all the recent deals closed by the various Columbia distributors, as Wholesale Manager Yerkes has on his desk the names of many new representatives in all parts of the country, which will be announced in the near future.

Among the new Columbia dealers in near-by territory are the following: Joseph Michaels, a prominent and successful furniture dealer, with stores at 184 Smith street and 22 Grand street, Brooklyn, N. Y., and a third store at 503 Fifth avenue, Brooklyn, N. Y., under the name of Michaels & Co.; Columbia products will be handled in all three stores; R. D. Baker & Son, Warrensburg, N. Y.; the Franklin Parlors, Englewood, N. J.; B. Feldman & Sons, Little Falls, N. Y.; Eugene Weber, College Point, N. Y.

Wholesale Manager Yerkes was also advised last week of the closing of an important deal with the Gilchrist Department Store of Boston, Mass., one of the best-known stores in New England, which is arranging for an aggressive exploitation of Columbia machines and records.

HEAVY DEMAND FOR DANCE RECORDS

(Special to The Talking Machine World.)

BUFFALO, N. Y., March 4.—No sooner had the Columbia Graphophone Co. at 622 Main street announced the Columbia dance records when the store was rushed with orders from all over the city. Dealers in Victor dance records have also been swamped with orders so that it is nearly impossible to fill them all at the present time.

Don't try to kill time. Time can stand the racket longer than you can.



The only change in Columbia dealers' profits during the last month has been an improvement.



(Write for "Music Money," a book "full of meat" for those dealers interested in quick and frequent turnover of capital.)

Columbia Graphophone Company
Woolworth Building, New York

STOCKS STILL REPORTED SHORT IN WISCONSIN.

Lively Business Prevents Jobbers and Dealers from Catching Up with Demands—Higher Priced Machines Have the Call—Miss Gannon on a Visit to the East—Arranging to Start New Columbia Dealers—John H. Becker Resigns—General News of Interest.

(Special to The Talking Machine World.)

MILWAUKEE, WIS., March 9.—The shortage of machines and records which has been experienced by Milwaukee jobbers and dealers since the opening of the new year does not seem to have been overcome and the complaint is heard on all sides that more business than is being received could be handled if the goods were only available to fill orders. Stock of Victor machines and records seem to be especially low, and dealers are having trouble in meeting the demands of the trade. Stocks in dealers' hands were badly reduced by the Christmas trade, and they have been trying to replenish ever since.

Dealers in Milwaukee and about the State say that the February business was unusually good, but that their stocks have been badly depleted as a result. General business conditions have shown decided improvement since the first of the year, and this has reacted with favor upon the talking machine trade. General confidence is more widespread, money is a little easier and collections have naturally improved.

"Business has been very good during the past month or so," said Miss Gertrude F. Gannon, head of the Wisconsin Talking Machine Co., jobber for the Victor line. "We would probably be locating more new dealers if we were able to get more machines and records for distribution."

Miss Gannon recently returned from a short business trip in New York and other Eastern points.

The sale of high-class Victrolas at the Edmund Gram Piano House during February, more than doubled the number of machines sold during the corresponding period a year ago. The record business at the store has also been unusually good, according to Paul A. Seeger, manager of the Victor department.

L. C. Parker, the enterprising manager of the Victor department at Gimbel Bros.' Milwaukee store, has been making some more good sales of the Victor V and the small Victrolas to the Milwaukee schools. Mr. Parker was really the pioneer in selling Victors to the local schools, and he worked with Mrs. Frances E. Clarke, former supervisor of music in the Milwaukee public schools, now with the Victor Talking Machine Co., in arranging courses so that the talking machine could be utilized, especially in the grades. Mr. Parker and his sales force recently sold several machines to the Milwaukee Social Center, where they are being used to good advantage. General business in the Gimbel department is good, according to Mr. Parker.

The Columbia goods have been increasing in popularity to such an extent of late that A. G. Kunde, Columbia dealer and jobber, 516 Grand avenue, is preparing to start several new dealers who will handle the Columbia line in Milwaukee. "The most phenomenal feature of our business

during February was the big increase in the record trade," said Mr. Kunde. "Our sales of records showed a gain of 100 per cent., as compared with the corresponding period a year ago. The demand for machines has been exceptionally good also."

C. W. Abbott, manager of the Victor department at the Boston store, is meeting with an especially good business in the Victrolas X, XI and XIV at the present time. Demand is strong, he says, for all the high class machines. Mr. Abbott has found that the scheme of maintaining salesmen to cover the outside trade is working out favorably and he believes that it is a plan which every department store could follow with success. Work

MAKE MOST ATTRACTIVE DISPLAY.

The Furnishing and Decoration of the Store of the Columbia Co., Inc., in Norfolk, Va., Has Won High Praise from Critical Visitors.

(Special to The Talking Machine World.)

NORFOLK, VA., March 4.—One of the most attractive stores in the local talking machine trade is that of the Columbia Co., Inc., 67 Plume street, this city. Every detail in the furnishing and decoration of this store is in accord with the high-

will soon start at the Boston store for the purpose of doubling the size of the Victor talking machine department.

The J. B. Bradford Piano Co., which now maintains a highly successful Victor department, has consistently kept up its campaign of advertising the Victor goods in the Milwaukee newspapers, and the results have been more than satisfactory. Some especially fine sales of high-grade Victrolas are reported by officials of the Bradford house.

John H. Becker, Jr., one of the best known young talking machine men of Milwaukee, has resigned his position with the retail Victor store of Miss Gertrude F. Gannon. Mr. Becker has not completed his plans for the future as yet, but it is expected that he will again enter the Victor field at some point after he has enjoyed a short vacation.

U. P. Gibbs, well known traveler for the Rudolph Wurlitzer Mfg. Co., of Cincinnati, O., recently called upon the Milwaukee trade.

Co.'s line. In addition to the sales value of this type of machines, there is no doubt but that table machines lend themselves peculiarly to the distinctive arrangement of a store display, and this is well evidenced by the distinctive appearance of the company's main display room.

The Columbia Co., Inc., is closing an excellent business with Columbia machines and records which is aided considerably by its aggressive advertising campaign in the daily newspapers. In addition to this consistent advertising, the com-



Showrooms of the Columbia Co., Inc., Norfolk, Va.

est ideals of dignity and taste, and the many out-of-town visitors who have called at the headquarters of the company while on a visit to the city, have been unanimous in their praises of its artistic appearance and comfortable and home-like atmosphere.

As will be seen by the accompanying illustration, the Columbia Co., Inc., makes a specialty of displaying the popular table machines that form such an important part of the Columbia Graphophone

pany features informal concerts at its store, where the beautiful Columbia "Grand" is presented to excellent advantage.

To the credit men, with their ears glued to the ground, there is beginning to be very audible a growing rumble that presages a wave of good business and good collections. It's on the way, and the fellow that is ready is going to ride its crest to increased success.

TALKING MACHINE JOBBERS IN SESSION.

Executive Committee of the National Association of Talking Machine Jobbers Holds Mid-Winter Meeting in Philadelphia and Consults with Victor Co. Officials at Factory—Plan for Discussion of Important Matters at Convention at Atlantic City, July 6 and 7.

(Special to The Talking Machine World.)

PHILADELPHIA, PA., March 3.—The regular mid-winter meeting of the executive committee of the National Association of Talking Machine Jobbers was held at the Bellevue-Stratford, on Sunday, February 15, with a second meeting with the officers of the Victor Co. at the factory at Camden on Monday, and the sessions proved to be among the most interesting and resultful of any ever held by the governing body of the association.

increase its output and to take care of the unprecedented growth in demand.

The jobbers came away with the feeling that though deliveries in some departments were naturally slow, the company was using every effort to bring the output to a point where it would meet demands promptly. The plant is at present working four nights each week and new record presses are being installed at the rate of two per week to meet a demand for records that sometimes reaches

problems that a member cares to bring up through that medium will be not only considered by the association, but also when desirable by the factory officials.

The arrangement committee of the association, represented by L. C. Wiswell, E. C. Rauth, A. A. Trostler, held its first meeting in Chicago later in the same week, for the purpose of making preliminary plans for Atlantic City sessions.

MILWAUKEE CONCERN EXPANDS.

Gensch-Smith Co., Victor Dealer, Adds Line of Automatic Pianos to Its Business.

(Special to The Talking Machine World.)

MILWAUKEE, WIS., March 9.—The Gensch-Smith Co., operating an exclusive Victor shop at 700



Officers National Association of Talking Machine Jobbers.

First Row (left to right)—W. H. Reynolds, Treasurer; Geo. E. Mickel, Vice-President; J. C. Roush, President; Perry B. Whitsit, Secretary; James F. Bowers, Executive Committee. Second Row (left to right)—R. H. Morris, O. K. Houck, T. H. Towell, E. C. Rauth, also Members of the Executive Committee.

The meeting was attended by a full executive committee, including President J. C. Roush, Pittsburgh; Vice-President Geo. E. Mickel, Omaha; Treasurer W. H. Reynolds, of Mobile, Ala.; Secretary Perry B. Whitsit, Columbus, O., and Jas. F. Bowers, Chicago; R. H. Morris, Brooklyn, N. Y.; O. K. Houck, Memphis, Tenn.; T. H. Towell, Cleveland, O., and E. C. Rauth, of St. Louis, this being the second time since the convention that the full committee has convened, the first meeting having been held in Chicago. In addition to the committee members, there were also present of the members at large E. F. Taft, of the Eastern Talking Machine Co., of Boston; J. N. Blackman, Blackman Talking Machine Co., New York; Louis Buehn, Philadelphia; L. J. Gerson, with John Wanamaker, New York and Philadelphia; C. A. Bruce, president of the Standard Talking Machine Co., Pittsburgh, and Chas. F. Bruno, of C. Bruno & Son, New York, who took occasion to file an application for membership in the association.

The session on Sunday occupied all day and was given over to a general discussion of the problems that confront the jobber in the trade at large, including the completion of plans for the coming convention at Atlantic City, for which July 6 and 7 has been selected as the dates.

On Monday morning the jobbers went to the Victor factory, where they were met by Louis F. Geissler, general manager; Chas. K. Haddon, treasurer, and other officers and department heads. Various matters brought up by the jobbers were threshed out in conference with generally satisfactory and harmonious results, the committee being particularly pleased with the cordial manner in which they were received. Following the conference the jobbers were taken through the various departments of the factory and asked for suggestions that would tend to enable the company to

100,000 records per day. The facilities of the needle department have also been increased, and it is stated that in thirty days all back orders will have been filled. The company also took occasion to announce that a new and most liberal record cut-out and sales proposition would be issued in April.

One of the interesting features of the visit of the jobbers to the factory was the demonstration of the actual qualities of various needles for their benefit with a view to proving the claims of the needles for Victor records. Needles of the various makes were shown under a powerful microscope, which was very effective in emphasizing any imperfections that were hidden to the naked eye and therefore not generally appreciated.

Upon leaving Camden the majority of the jobbers went immediately to their homes, although Messrs. Taft, Towell, Roush, Bowers and Whitsit elected to spend some time in New York. In discussing the plans for the convention, President Roush said: "We wish specially to emphasize this year that the business of the convention will receive the first consideration and the social end will be relegated to second place, for it is the ambition of the officers to have every member leave the convention with the feeling that his time and money has been well spent, and that he goes home with increased knowledge regarding his business.

"We are making a special campaign to have the heads of the concerns attend the convention as well as the managers, for we feel that many of those not in closest touch with their talking machine departments have little idea of the extent of the business or what we are doing. This does not mean that we will not welcome the managers as in the past, we want them and want them badly, but we want the managers to bring the heads of their companies with them. One of the features of the convention will be a question box, and any

Grand avenue, has extended its field of activity and has launched into the piano field. The company has secured the Wisconsin agency for the Wurlitzer pianos and foot-operated players, and will henceforth give considerable attention to this phase of the business. An adjoining store has been leased, a connecting arch has been cut through and the Wurlitzer line will be displayed in the new quarters, which are 30 x 16 feet in dimension. Another new outside salesman has been secured, making three men now covering the city of Milwaukee and the surrounding territory. The company has just installed a large show case, where needles, talking machine supplies and a small line of musical merchandise have been placed on display.

WM. P. HOPE APPOINTED MANAGER.

Popular Milwaukee Talking Machine Man in Charge of New Kansas City Concern.

(Special to The Talking Machine World.)

MILWAUKEE, WIS., March 7.—William P. Hope, traveling representative in Wisconsin and upper Michigan for Thomas A. Edison, Inc., for the past eight or nine years, and one of the most popular talking machine men in this section of the Northwest, has been made manager of the Western Phonograph Co., at Kansas City, Mo., a jobbing branch which is handling the Edison line. Wisconsin and Michigan dealers and the Milwaukee Phonograph Co., jobber for the Edison line in this territory, regret Mr. Hope's departure, but they all wish him the best of success in his new field. Mr. Hope's successor on the road has not been announced as yet.

A good guesser is generally a man who prides himself on his superior judgment.



**The Columbia Grafonola "Favorite"—\$50.
Still the most popular talking machine
in the industry.**



(Write for "Music Money," a book "full of meat" for those dealers interested in quick and frequent turnover of capital.)

**Columbia Graphophone Company
Woolworth Building, New York**

COLUMBIA GRAPHOPHONE CO. INVADES FIFTH AVENUE.

To Have Splendid Quarters in Heart of Shopping District at Fifth Avenue and Thirty-third Street—Full Line of Instruments and Records to Be Displayed in Artistic Environment—The Booth Equipment Throughout Will Be of the Latest and Best Procurable.

The Columbia Graphophone Co. is invading upper Fifth avenue, New York City. By arrangement with its dealers, the F. G. Smith Piano Co., there is to be a Columbia corner at Fifth avenue and Thirty-third street.

Here, opposite the Waldorf-Astoria, and in the

all three are being most satisfactorily achieved.

The scheme of decoration followed is distinguished by artistic elegance and studied attention has been paid to the most effective display of product in every detail.

There will be, of course, an absolutely complete



Where the Columbia Line Will Be Handled at Fifth Avenue and Thirty-third Street, New York.

center of New York's most fashionable shopping district, the Columbia Graphophone Co.'s product is to be displayed in a store conspicuously handsome even on that great avenue of handsome stores. There is tremendous spread of plate glass show window facing on Thirty-third street and also on Fifth avenue, permitting a magnificent display of talking machine products.

The basement, ground floor and mezzanine of the store provide 7,500 square feet of space for this new home of Columbia. The entire interior of the store is being reconstructed, refurnished and redecorated, and the three essentials that have been adhered to in this work are the comfort of customers, the efficiency of the service and artistic presentation in all things. It is safe to say that

line of instruments and records. Demonstration booths are being built on each floor and every facility has been provided for the maintenance of a retail service in keeping with the locality.

This move may be regarded as an eloquent indication of the vigor with which the Columbia Graphophone Co. is strengthening its position in New York and the East in general.

DECISION ON RESALE PRICES.

Resale Decision Against Waltham Watch Co. Upheld by United States Supreme Court.

(Special to The Talking Machine World.)

WASHINGTON, D. C., March 9.—The Supreme Court on Tuesday refused to review the decision of the Federal courts at New York, holding the Waltham Watch Co. could not fix the resale prices of watches by retailers.

* * * * *

The Waltham Watch Co. sought last month to enjoin Charles A. Keene, a Broadway jeweler, from selling a watch movement manufactured by the Waltham concern, and known as Size 16 Riverside, at less than the price fixed by the manufacturers. Mr. Keene, in his answer to the petition, alleged that the Waltham Co., though it charged \$28.50 for the movement in this country, sold it to exporters for \$10. In dismissing the application for the injunction the court here held that it was contrary to public policy to permit a patentee to prescribe the terms of resale.

HAS WON A MARKED SUCCESS.

Miss Clara B. Elting, Manager of the Victor Department of E. Winter's Sons in Kingston, Has Introduced Several New Sales Ideas.

(Special to The Talking Machine World.)

KINGSTON, N. Y., February 23.—Miss Clara B. Elting, who was recently appointed manager of the Victor department of E. Winter's Sons, the prominent piano house of this city, is achieving a very pleasing success. Although her connection with this firm is her first experience in the talking machine trade, she has already shown a peculiar aptitude for this line of work that seems to insure her an excellent sales record in a very short while.

In addition to maintaining a Victrola department that is in perfect accord with the high standing of E. Winter's Sons in the piano industry, Miss Elting has introduced several new sales ideas that have proven of considerable assistance in the conducting of her department. One of her recent selling helps was the thumb indexing of the Victor red seal catalog so that it is possible to tell a customer at a moment's notice just what records are presented by Caruso, Paderewski, Elman, etc. By this simple plan Miss Elting can show the names and numbers of the red seal records to her customers with a maximum of convenience and speed.

NEARLY FOOL-PROOF.

Advertising is nearly fool-proof. No persistent advertising of an article of merit has ever failed in the United States.

CHEMISCHE FABRIK **E. SAUERLANDT** FLURSTEDT bei Apolda i. Th., Germany
The largest manufacturing plant in the world devoted exclusively to the manufacture of Master-Waxes and Master-Blanks for
Gramophone and Phonograph Recording
Sole Manufacturer of Wax "P." the best recording material for Berliner-cut.

NEAL, CLARK & NEAL CO.'S NEW HOME

One of the Handsomest Talking Machine Establishments in Buffalo or Elsewhere—Artistically Appointed—Business Is Excellent.

(Special to The Talking Machine World.)

BUFFALO, N. Y., March 7.—The new store occupied by the Neal, Clark & Neal Co. is one of the handsomest talking machine establishments in this city. Nearly \$10,000 has been spent fitting up the premises.

The photograph showing one of the views of the establishment, which is reproduced herewith, does not do justice obviously to the color and decorative scheme employed and which makes the establishment one of exceeding attractiveness, with an atmosphere that tends to make one at home.

The booths are of French gray, light and dark, and the walls are finished with blue bur-lap. The rugs used are genuine Oriental, with



Booth Facilities in Neal, Clark & Neal Co.'s New Store.

having an especially strong call at the present time.

NEW MISBRANDING BILL.

Congressman Rogers Applies Law New Covering Only Food Products to All Articles Sold.

(Special to The Talking Machine World.)

WASHINGTON, D. C., March 9.—Congressman Rogers of Massachusetts has introduced in the House a bill embodying the results of considerable research into the laws of this country and Great Britain to prevent the manufacture, sale or transportation of misbranded articles and for the regulation of the traffic therein. Mr. Rogers said today:

"The bill I have drafted is a misbranding act; that is, it protects the customer against fraud or negligent misrepresentation on the part of manufacturers or dealers. It differs from most of the proposed legislation, which applies only to fabrics and leather—it is universal in its application, covering all articles; I can see no reason why the purchaser of a piano or a watch should not be cared for as well as the purchaser of a pair of shoes. We have had since 1906 on our statute books a pure food law which prohibits the misbranding of food-stuffs. The pure food law has been extremely effective in its operations and its validity has been sustained by the courts. The proposed law, as it seems to me, supplies an inexplicable shortcoming in our Federal legislation by in effect extending the provisions of the pure food law to all commodities.

"Great Britain has had on its statute books since 1887 an analogous misbranding act which has worked very well. So far as applicable I have adopted the language of the pure food act and have embodied much of the very broad and detailed definitions in the British act of what shall be deemed misbranding."

VOICE CULTURE WITH PHONOGRAPH.

After a conference with Thomas A. Edison, Signor Uribe, of New York City, a teacher of voice culture and a grand opera singer, announces that he has adapted an Edison phonograph to aid him in his classes, and that the result is remarkable in promoting true tones and correct enunciation. The value of many of the grand opera and concert selections as examples of fine vocal power is readily conceded. So enthusiastic has the Signor become that he plans to give a public recital at an early date, showing how the Edison assists him in his classes.

Welcome trials, for remember it is usually difficulties and responsibilities that bring a man to the fore.

color effects in harmony with the general decorative scheme.

The business of the establishment is excellent and B. E. Neal of the firm stated to The World that their retail business had increased wonderfully since the work on their new quarters had been completed. There is an enormous demand for records of all kinds with dance numbers

company's balance surplus and reserve account on January 1, 1914, stood at \$866,588, as compared with \$601,128 on January 1, 1913."

INTRODUCE TELELECTROPHONE.

A Combination of the Talking Machine and Telephone Makes Its Appearance in the Gimbel Store in Philadelphia and Excites Considerable Interest and General Favor.

(Special to The Talking Machine World.)

PHILADELPHIA, PA., March 9.—The telepho- phone, a combination of the telephone and talking machine, has been introduced for the first time in this country by Gimbel Bros.' department store and placed at the disposal of all who care to use it.

Beginning at 9 o'clock, the telepho- phone—there are thirty of them in use in the store—gives a concert, flashes news bulletins, recites menus for the benefit of the housewife, and during the afternoon rattles off current market reports and sporting events. Plans are under way to have the telepho- phone reproduce grand opera during the evening, when the service shall have extended to homes. This is another story, however.

JOINS RECORDING DIVISION.

Harold W. Lyle, a son of General Manager George W. Lyle, of the Columbia Graphophone Co., is now connected with the recording division of the company in the capacity of assistant to Manager Heindl, of the foreign record department. He is acquiring an intimate knowledge of the grapho- phone business, as he was a member of the selling staff of the Chambers street store for some time, and more recently was connected with the factory.

CONCERT HELPS RECORD BUSINESS.

(Special to The Talking Machine World.)

BUFFALO, N. Y., February 23.—According to W. J. Bruehl, manager of the Victrola department of the Neal, Clark & Neal Co., the demand for Tetrastini and Ruffo records was brisk during the past week. Mr. Bruehl said that after a concert by famous artists the demand for records is always heavy.

EDISON GOES ON VACATION.

Thomas A. Edison left West Orange, N. J., Saturday to "get back to nature." Accompanied by his family, Henry Ford, the automobile maker, and John Burroughs, the naturalist, the noted inventor left for his winter home at Fort Myers, Fla. Included in the party besides Mrs. Edison were their two sons, Charles and Theodore, and their daughter, Miss Madeleine.

Special

Send for a package of our Improved Half-Tone and Loud Tone Needles in New Style Envelopes.

If you want to advertise yourself, we will put your own name or trade-mark on the envelopes, or will pack in Puritone envelopes.

Quality Guaranteed

The Best Needles mean profit and satisfaction.

If you want to sell 1,000 Needles at a time instead of 100, use the "Dean-packed" Needles. Five boxes of 200 each, Extra Loud, Loud, Opera, Medium and Soft packed in a carton. The best package and fastest seller on the market. Write for samples.

JOHN M. DEAN, CORP.

Talking Machine Needle Manufacturers

PUTNAM, CONN.

LATEST PATENTS RELATING TO TALKING MACHINES AND RECORDS

(Special to The Talking Machine World.)

WASHINGTON, D. C., March 10.—SOUND BOX, Henry C. Miller, Waterford, N. Y. Patent No. 1,087,035.

This invention relates to improvements in sound boxes for talking machines.

The object of the invention is to provide a "fret" held spring plate fulcrum, a pad acting the same as finger pressure over the fret to give a certain note, as in the case of an instrument such as a mandolin or guitar.

A further object of the invention is to provide a self-adjusting means on the stylus lever to permit the latter to be in yielding contact with the diaphragm, irrespective of the adjustment of the fulcrum, also to recompense for the dishing of the diaphragm by an adjustable modifying element and its actuating means.

In the drawing Fig. 1 is a side elevation of the improved sound box. Fig. 2, is a view looking from the opposite side. Fig. 3, is a transverse sec-

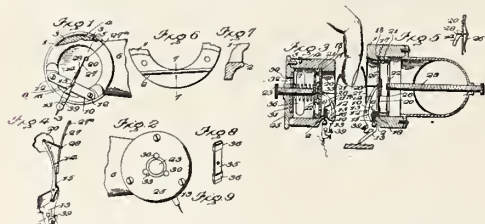

tion on the line 3-3 Fig. 1. Fig. 4, is a detail perspective view of the stylus lever. Fig. 5, is a transverse section showing the adaptation of the invention when used in connection with a record having vertical indentations in its groove. Fig. 6, is a detail front elevation of the front of the casing to bring out clearly the formation of the fret. Fig. 7, is a detail section on line 7-7 Fig. 6. Fig. 8, is a detail perspective view of one form of modifying element. Fig. 9, is a detail view of a further modified form of modifying element.

TALKING MACHINE ATTACHMENT.—William C. Holland, Niagara Falls, N. Y. Patent No. 1,087,493.

This invention relates to talking machine attachments, and the principal object of the invention is to provide a simple and efficient device for automatically stopping the rotation of the record and for lifting the needle therefrom.

A further object of the invention is to provide a device of this character which may be adjusted for use on different sized records and for use on different types of machines, so that the attachment may be sold for universal use.

Further objects of this invention will appear as the following specific description is read in connection with the accompanying drawing, which forms a part of this application, and in which:

Fig. 1 is a top plan view showing the attachment applied to an ordinary disc talking machine. Fig.

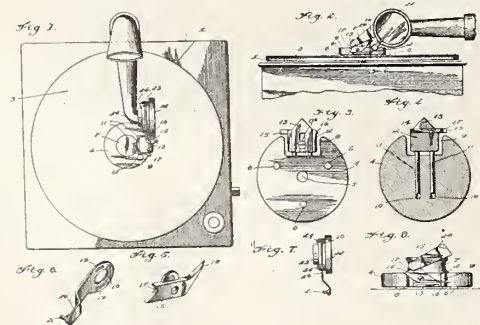

2 is a side elevation thereof. Fig. 3 is a bottom plan view of the attachment removed. Fig. 4 is a horizontal sectional view through the attachment. Fig. 5 is a perspective view of the tripping dog supporting head removed from the attachment. Fig. 6 is a perspective view of the reproducer lifting arm removed. Fig. 7 is a detailed edge elevation of said arm showing its association with the reproducer or sound box. Fig. 8 is a side elevation

showing the position of the parts when operated.

SOUND BOX.—Peter Weber, Orange, N. J. Patent No. 1,087,339. In the manufacture of phonograph records as carried on by modern processes, it frequently happens that the record groove is slightly distorted; that is to say, it does not follow a theoretically correct helix around the surface of a cylindrical record, or a correct spiral around the face of a disc record. The best practice in phonograph construction requires that the sound boxes be mounted rigidly against lateral movement and that the box body be pivoted to oscillate in a plane perpendicular to the axis of the cylindrical record or to the plane of the disc record; or to provide means whereby the stylus may oscillate in a vertical plane where the entire sound box is held against movement in any direction. Unless some provision is made for a slight lateral movement of the stylus under the conditions above named, the stylus itself will not track properly in the record groove, with the result that the disagreeable scratching and the jumping of the stylus from the one groove to the next will take place.

The purpose of this invention is to provide the stylus and its connection with the diaphragm of the sound box with means whereby said stylus may oscillate laterally and thus be caused to follow the record groove no matter how distorted such grooves may be or how unevenly the mandrel upon which the record is mounted may run. The structure whereby this result is accomplished is applicable to either form of sound box; that is to say that form in which the sound box is permitted to oscillate bodily toward and away from the record, or that form in which the sound box is held rigidly against movement in any direction. This invention is also shown as applied to both forms of sound boxes and in the following description the full details of so much of said sound boxes will be set forth as will enable persons skilled in the art to which the invention pertains, to make, construct and use the same.

In the accompanying drawings forming a part of this specification, Fig. 1 is an enlarged side ele-

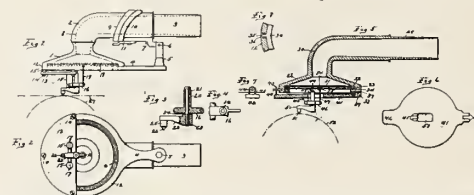

vation of a sound box and its connection, designed to oscillate about a pivot in a plane perpendicular to the axis of a cylindrical record. Fig. 2 is a bottom plan view of the same. Fig. 3 is a detached vertical section through the stylus arm bearing and stylus lever. Fig. 4 is a plan view of the stylus lever showing the tubular bearing for the stylus arm. Fig. 5 is a vertical section of a sound box which is designed to be held rigidly fixed. Fig. 6 is a bottom plan view of the floating weight. Fig. 7 is an end view of the connection between the floating weight and the sound box body. Fig. 8 is a view partly in section of the sound box body and the metallic retaining washer for the gaskets.

TALKING MACHINE.—Walter H. Pumphrey, New York, N. Y., assignor to the American Graphophone Co., Bridgeport, Conn. Patent No. 1,087,256.

This invention relates generally to talking machines and more particularly to the construction and mounting of the sound conveying tube or tone arm employed in connection with such machines.

The object of the invention is to simplify the construction and dispense with small parts in mounting the tone arm and at the same time give it the required freedom of movement in planes parallel and at right angles to the surface of the record.

The accompanying drawings will serve to illustrate several forms suitable for carrying this in-

vention into effect. It should be understood, however, that the inventor does not limit himself to the exact constructions shown in the drawings, as various changes may be made therein within the meaning of the present invention.

In the drawings, Fig. 1 is a view in elevation, partly in section, showing the application of im-

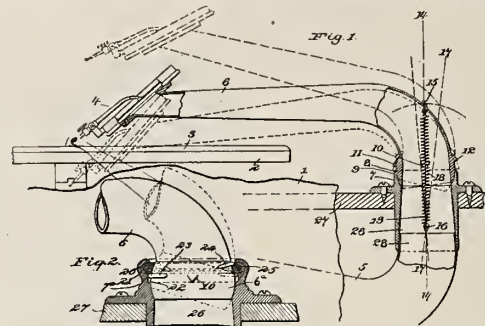

proved form of mounting to a modern talking machine. Fig. 2 is a detail sectional view illustrating another form which the invention may assume.

PHONOGRAPH.—Pliny Catucci, Newark, N. J., assignor to A. F. Meisselbach & Bro., New Jersey. Patent No. 1,085,849.

The principal object of this invention is to so improve the construction of a phonograph as to materially increase its efficiency as a device for the reproduction of musical and other sounds, but also to reduce its cost of manufacturing to the lowest possible point, consistent with good material and workmanship.

In the development of the phonograph art it has been found that there is an increased demand for what is called the four-minute cylindrical record. The two-minute record—that is, a record that requires a period of two minutes to reproduce the entire matter placed thereon—has necessitated the use of a feed screw having 100 threads to the inch. The extreme fineness of this thread has laid it open to the objection that, in use, the thread was easily marred or damaged by coming in contact with other hard substances, and thereby, the delicacy and efficiency of this machine was very much impaired. If the pitch of the thread was decreased to, say fifty to the inch, the thread would be materially strengthened and much more capable of withstanding the hard usage to which such an instrument is usually put. Such a reduction in the pitch of the thread would correspondingly reduce the length of time occupied in reproducing the matter upon the cylindrical phonograph records.

By the former methods of construction, if a four-minute record was desired, it was necessary to correspondingly increase the number of threads on the feed screw to 200 to the inch. It will be readily seen that a feed screw of this extreme fineness would be too delicate for the practical application of the phonograph to ordinary use.

By this improvement, the inventor is enabled not only to reduce the number of threads upon the feed screw to fifty to the inch, and thereby correspondingly increase their strength and resistance to ordinary rough usage, but other features of the improvement enable him to utilize both the two-minute and four-minute records.

Fig. 1 is a plan view of the improvement with

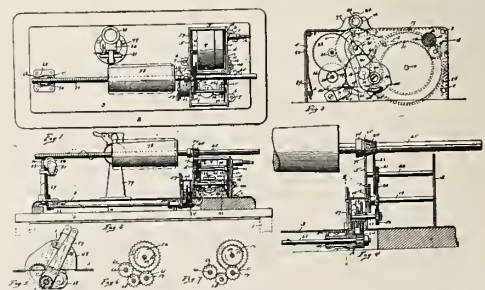

the cover for the motor removed to disclose the interior. Fig. 2 is a side elevation partly in section of the completed structure. Fig. 3 is an end elevation partly in section of the motor, and its governing mechanism. Fig. 4 is a sectional view on line X, X, of Fig. 5. Fig. 5 is a vertical view on line Y, Y, of Fig. 4. Fig. 6 is a diagrammatic section of the subtransmission gear train for repro-

ducing two-minute records. Fig. 7 is a similar view showing the gear shifted to reproduce the four-minute records. Figs. 6 and 7 are taken in substantially the same positions as represented in Fig. 5, in the full line and dotted line positions of the shifting lever 57.

PHONOGRAPH.—Pliny Catucci, Newark, N. J., assignor to A. F. Meisselbach & Bro., New Jersey. Patent No. 1,087,106.

This invention relates to phonographs for use in connection with the reproduction of sound by means of records, and has for its object the general improvement of the various details of the phonograph, and is intended broadly to include means for relatively separating the sound box from the record support at a predetermined point or position, which in practise is fixed as at the end of the selection upon the record. This separation of sound box and record may be by permitting the record support to rotate at a relatively fixed position and providing means for elevating the sound box and its stylus free from the record, or on the other hand, the sound box itself may be made to occupy a relatively fixed position with the stylus point resting upon the face of the record, with means for withdrawing the record and its support from contact with the stylus and providing such means with additional parts whereby such withdrawal will stop the motor and consequently the rotation of the record support.

Other features of improvement relate particularly to the motor and the means for winding up the motor spring; the turn table and the method of mounting the same, whereby the table itself has a flexible connection with the drive shaft upon which the same is mounted, and important improvement is made in the sound conveyor whereby the sound box may be rotated through an angle of substantially 180 degrees to carry the stylus of the sound box out of and into position for engagement with the record disc; another important feature resides in the sound conveyor, the same being made

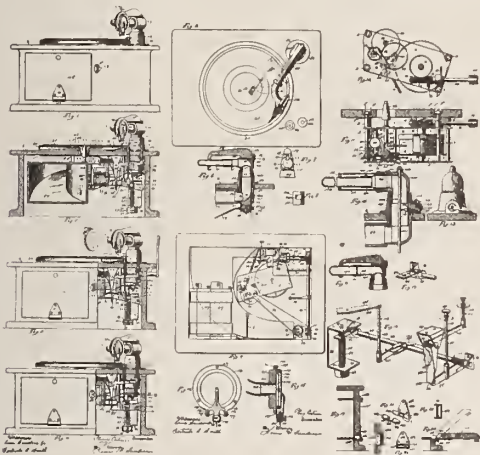

of telescoping parts with connections whereby the movable telescoping part may be actuated to be lifted through a distance sufficient to carry the stylus of the sound box entirely free from the record, as for example, at the end of the rendition of the selection upon the record; another feature of the invention embodies automatic mechanism whereby, at the close of a rendition of a selection, the sound box and its stylus are raised clear from the record and simultaneously the motor is automatically stopped. There is also provided a novel form of trap door for the outer end of the sound conveyor, so that the sound waves as they pass from the sound conveyor to the open atmosphere may be damped or muffled to any desired degree.

In the accompanying drawings, Fig. 1 is a front elevation of the improved phonograph showing the sound box and conveyor in elevated position. Fig. 2 is a plan view of the same. Fig. 3 is a view similar to Fig. 1 with the left hand end of the case broken away to expose a part of the automatic mechanism in the interior of the case, and showing the sound box and conveyor in elevated position. Fig. 4 is a view similar to Fig. 3, but with the sound box in a position occupied during the completing of a record. Fig. 5 is a sectional view showing the interior mechanism in the positions occupied by them when the motor is stopped and

the sound conveyor elevated. Fig. 6 is a vertical section of the mechanism showing the details of the mechanism and the various bearings connected therewith. Fig. 7 is an end elevation of the sound conveyor showing the stops for limiting the position of the sound box when the same is either in the position for playing or in reversed position for the readjustment of the stylus needle. Fig. 8 is a side elevation of a short portion of the telescoping conveyor tube showing the limiting set screw. Fig. 9 is a bottom plan view of the structure illustrating the position of the motor and the details of the stop mechanism. Fig. 10 is a top plan view of the motor showing the details of the winding mechanism and of the hand mechanism for stopping the motor. Fig. 11 is a side elevation of the motor disconnected from the case. Fig. 12 is a longitudinal section and a modification of the sound conveyor showing the means employed for elevating the same. The elevating device of this

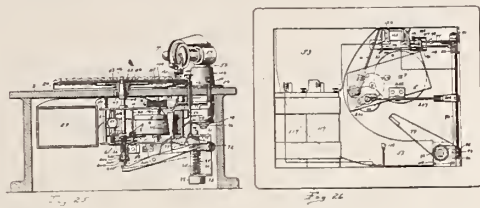

modification contemplates the omission of the automatic elevating device as illustrated in the other figures. Fig. 13 is an end view of the modification illustrated in Fig. 12 showing the hand lever for elevating the sound box and telescoping sound conveyor by hand. Fig. 14 is a front elevation of the sound box showing the details of the stylus lever. Fig. 15 is a vertical sectional view of the same. Fig. 16 is a detached view in perspective of the operating rock shaft hereinafter referred to. Fig. 17 is a detached perspective view of one end of said shaft. Fig. 18 is a vertical sectional view of a still further modified form of a sound conveyor. Fig. 19 is a sectional view through the spring hinge structure for the amplifying part of the phonograph. Fig. 20 is a horizontal sectional view of the hinge through its axis. Fig. 21 illustrates the parts of the hinge structure separated to show their details. Fig. 22 is a rear view of the door section of the hinge. Fig. 23 is a sectional view of one of the hinge members. Fig. 24 is a sectional view similar to Fig. 19, showing the limiting position of the door and its various adjustments. Fig. 25 is a side elevation of the mechanism within the case, showing the structure whereby the record support may be raised and lowered, the general features of the structure being the same as illustrated in the preceding figures. Fig. 26 is a bottom plan view of the structure shown in Fig. 5.

BLANK FOR TALKING MACHINE RECORDS.—John Schumacher, Chicago, Ill., assignor to Joseph Sanders. Patent No. 1,082,709. The objects of the present invention are to provide a record blank which is less expensive, of less weight, and less liable to breakage than blanks made wholly of shellac or of a composition of which shellac is the principal ingredient, or of other plastic material.

With this object in view, the inventor makes the blank of a body or core of some flexible porous material, such, for example, as cardboard or blotting paper. This body or core is first sized in a

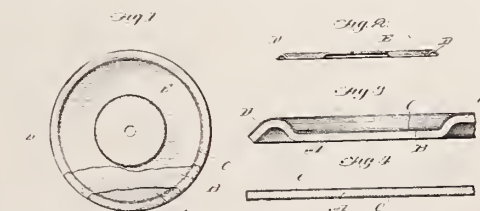

manner that wholly prevents the shellac from penetrating it. This body or core is coated on one or both of its faces with a plastic material, such as shellac or a composition containing shellac, which is adapted to receive and retain impression. The helical groove of the record is only an almost infinitesimal fraction of an inch in depth, and in order to meet the requirements in this respect it is

only necessary that the coating be of sufficient depth to receive the groove.

In its completed condition the blank is a normally flat disc of sufficient rigidity to maintain or substantially maintain its normal shape in ordinary handling. That is to say it may be handled precisely as the above described blanks or records at present in use are handled and if held at one side and in horizontal position, it will not bend appreciably under its own weight. At the same time it does not have the rigidity and therefore it does not have the fragility of the records of commerce.

In the accompanying drawing, which is made a part of this specification: Fig. 1 is a face view of a record blank embodying the invention, portions of the size and plastic coating being broken away. Fig. 2 is a transverse section thereof. Fig. 3 is a section of a fragment thereof, thickness being exaggerated. Fig. 4 is an exaggerated section of a fragment of a blank of different form, embodying some features of the invention.

NEW WONDERS PREDICTED.

London Editor Says That Improved Phonographs Will Recount the Events of the Day to a Public Too Lazy to Read—Every Reporter of the Future to Have a Portable Wireless Telephone Outfit.

Robert Donald, editor of The London Daily Chronicle and President of the Institute of Journalists, painted a striking picture of the newspaper of the future in his Presidential address at the annual meeting of the institute held recently in York.

Mr. Donald said if he were to attempt to forecast the future he would say that newspapers would be fewer in number. The tendency toward combination would increase and colossal circulations would continue to grow. He added:

"The newspaper of the future will not contain less reading matter, but its pages will be smaller, methods of distribution will be quicker, and circulation will cover greater areas.

"Airships and aeroplanes will be used for the most distant centres. Electric trains and motorplanes running on special tracks will also be used. In all the chief centers of population papers will be distributed by electric or pneumatic tubes. Morning and evening newspapers will be merged and editions will come out almost every hour of the day and night.

"News will be collected by wireless telephone and a reporter will always have a portable telephone with him with which he will communicate with his paper without the trouble of going to a telephone. The wireless telephone messages will be delivered to the sub-editors in printed column form.

"At people's recreation halls, with the cinematograph and the gramophone or some other more agreeable instrument of mechanical speech, all the news of the day will be given hot from its source.

"People may become too lazy to read, and news will be laid out to house or office just as gas and water are now. Occupiers will listen to an account of the news of the day read to them by much-improved phonographs while sitting in the garden, or a householder will have his daily newspaper printed in column form by a printing machine in his hall just as we have tape machines in offices now."

Don't waste time explaining your actions; people prefer to draw their own conclusions.

50 YEARS' EXPERIENCE

PATENTS

TRADE MARKS
DESIGNS
COPYRIGHTS & C.

Anyone sending a sketch and description may quickly ascertain our opinion free whether an invention is probably patentable. Communications strictly confidential. HANDBOOK on Patents sent free. Oldest agency for securing patents. Patents taken through Munn & Co. receive special notice, without charge, in the

Scientific American.

A handsomely illustrated weekly. Largest circulation of any scientific journal. Terms, \$3 a year; four months, \$1. Sold by all newsdealers.

MUNN & Co. 361 Broadway, New York
Branch Office, 625 F St., Washington, D. C.

RECORD BULLETINS FOR APRIL, 1914

VICTOR TALKING MACHINE CO.

No.	Title	Size.
17538	Ma Poulette—One-step or Trot (C. J. Roberts) Victor Military Band	10
	Sebastian's Tango (Arthur N. Green) Victor Military Band	10
17542	Romance Waltz—Hesitation (Ernie Erdman) Vessella's Italian Band	10
	Ecstasi Tango (Ecstasy) (Leon Obrero) Vessella's Italian Band	10
17547	A Little Love, a Little Kiss (Un peu d'Amour) Waltz Hesitation (Lao Silésu) Victor Military Band	10
	Little Gray Home in the West—Waltz Hesitation (Lühr) Victor Military Band	10
17550	Thanks for the Lobster—Trot or One-step (Caddigan and Story) Victor Military Band	10
	What D'ye Mean You Lost Yer Dog?—Trot or One-step Victor Military Band	10
17553	Castle Walk (Jas. Europe-Dabney) Europe's Society Orchestra	10
	You're Here and I'm Here—One-step (from "Laughing Husband") (Jerome D. Kern) Europe's Society Orchestra	10
35370	Kiss Me Good-night Medley—Trot, One-step or Two-step Victor Military Band	12
	Ish ga Bible—Medley, One-step or Trot Victor Military Band	12
35371	Lukoumi—Tango (Ruis De Velasco) Victor Military Band	12
	Delicioso—Maxixe or Tango (Dixon) Victor Military Band	12
35372	Castle's Lame Duck (Jas. Europe) Europe's Society Orchestra	12
	The Castles in Europe—One-step Europe's Society Orchestra	12
17536	La Paloma (Yradier) In English Alan Turner	10
	O Sopa Mio (My Sunshine) Serenade (E. di Capua) In English Alan Turner	10
35365	Gems from "Queen of the Movies" (Paulton-Mac Donough-Gilbert) Victor Light Opera Co.	12
	Gems from "Sari" (Shar'ih) (Cushing-Heath-Kälman) Victor Light Opera Co.	12
17546	In the Night (When the Moon Slyly Winks) from "Queen of the Movies" (Paulton-Mac Donough-Gilbert) Lyric Quartet	10
	Oh Cecilia, from "Queen of the Movies" (Paulton-MacDonough-Gilbert) Lyric Quartet	10
17551	Sharpshooters March (Bersaglieri) (Resoís) (Accordion) Pietro Deiro	10
	Beautiful Days Waltz (S. Falco) (Accordion) Pietro Deiro	10

THE POPULAR SONG LIST

17537	Let's All Go 'Round to Mary Ann's (Macdonald-Carroll) Collins and Harlan	10
	Camp Meeting Band (Gilbert-Muir) Collins and Harlan	10
17539	Don't Blame it All on Broadway (Williams-Young-Grant) Peerless Quartet	10
	The Bells (Klein-Stilwell) Peerless Quartet	10
17543	A Fool There Was (Dubin-Benkhardt) De Los Becker	10
	Little Church Around the Corner (Gray-Carroll) De Los Becker	10
17544	In the Heart of the City that Has No Heart (Allen-Daly) Henry Burr	10
	The Woman Thou Gavest Me (Cobb-Powell) Harry Macdonough and Hayden Quartet	10
17545	'Cross the Great Divide (I'll Wait for You) (Lewis-Meyer) Harry Macdonough and Hayden Quartet	10
	When the Maple Leaves were Falling (Tell Taylor) Edna Brown-James F. Harrison	10
17552	I Miss You Most of All (McCarthy-Monaco) Edna Brown	10
	Would You Take Me Back Again (Lamb-Solman) Henry Burr	10

TWO FAMOUS WAGNER SELECTIONS.

35369	Siegfried's Funeral March, from "Götterdämmerung" (Richd. Wagner), Vessella's Italian Band	12
	Ride of the Valkyries, from "Die Walküre" (R. Wagner), Vessella's Italian Band	12

PURPLE LABEL RECORDS.

60113	The Good Ship Mary Ann (Kahn-LeBoy) Nora Bayes	10
60114	You Can't Get Away From It (Jerome-Schwartz) Nora Bayes	10
	TWO OF HARRY LAUDER'S 1914 SONGS.	
70106	The Portobello Lass (Harry Lauder-Gilbert Wells) Harry Lauder	12
70107	It's Nice to Get Up in the Mornin' (But It's Nicer to Lie in Bed!) Harry Lauder	12
	RED SEAL RECORDS FOR APRIL.	
87176	Amor Mio (My Love)—Vocal Waltz (Gaeta-Ricciardi) Tenor solo in Italian, Enrico Caruso	10
64401	Drink to Me Only with Thine Eyes (Old English Air) Mezzo-Soprano with orch. In English, Julia Culp	10
64402	Wiegandied (Cradle Song) Op. 49, No. 4 (Pianoforte by Coenraad V. Bos), (Brahms) Mezzo-Soprano Solo in German, Julia Culp	10
88452	Magdalen at Michael's Gate, Soprano Solo in English, with pianoforte by Gabriel Lapierre (Kingsley-Lehmann), Nellie Melba	12
88450	Marriage of Figaro (Nozze di Figaro) Deh vieni non tardar (Oh, Come, My Heart's Delight) (Act IV) (Mozart) Soprano Solo in Italian, Frieda Hempel	12
88463	Parla Valse (Oh, Speak) (Arditi) Soprano Solo in Italian, Frieda Hempel	12
64400	Carmena—Vocal Waltz (Walton-Wilson) Soprano Solo in English, Alma Gluck	10
87174	Don Giovanni—Serenade, "Fin ch' han dal vino" (Wine, Flow a Fountain!) (Act I) (Mozart) Baritone Solo in Italian, Titta Ruffo	10
74356	The Holy City (Weatherly-Adams) Tenor Solo in English, Evan Williams	12

NEW EDUCATIONAL RECORDS.

17548	Gloria Patria (Palestrina-Damrosch) In Latin, Victor Chorus	10
	Popule Meus (Palestrina-Damrosch) In Latin, Victor Chorus	10
17549	Secin' Things (Love Songs of Childhood) (Eugene Field) Cora Mel Patten	10
	I. My Shadow, 2. Where Go the Boats (Robert L. Stevenson), Cora Mel Patten	10

COLUMBIA GRAPHOPHONE CO.

SYMPHONY DISC RECORDS.

	By Jeanne Gerville-Reache, the Famous French Contralto, Double, 12-inch, Single.	
A5533	Samson and Delilah (Saint-Saëns), "Mon cœur s'éveille à ta voix" (Softly Awakes My Heart), In French with orch. Samson and Delilah (Saint-Saëns), "Amour	36832

	viens aider ma faiblesse" (Love, Lend Me Thine Aid), In French, with orchestra.	
	SYMPHONY DOUBLE-DISC RECORDS.	
A1488	Ach Wie Ist Möglich (How Can I Leave Thee?) In German, with orch., Mme. Fremstad	10
	Cradle Song (Wiegandied) (Brahms), In English, with orch., Mme. Fremstad	10
A1490	L'Heure Exquise (The Enchanted Hour) (Hahn) In French, with orch., Maggie Teyte	10
	Mifanwy (Poster), In English, with orch., Maggie Teyte	10

	BLUE LABEL DOUBLE DISC RECORDS.	
A1487	Andalusian Romance (de Sarasate) Violin solo, Cristeta Goni	10
	La Gallina Ciega, Habanera (de Sarasate), Violin solo, Cristeta Goni	10
A1491	Meet Me by Moonlight (Wade) Orch. accomp., Columbia Mixed Quartet	10
	Annie Laurie (Words by Scott), Orch. accomp., Columbia Stellar Quartet	10
A1492	Our Last Waltz (Only To-night) (Molloy) Baritone Solo, orch. accomp., Andrea Sarto	10
	Some Day I'll Wander Back Again (Huntley), Tenor Solo, orch. accomp., Harry McClaskey	10
A5534	Eily Mavourneen (Benedict), Tenor Solo in English, with orch. accomp., Ruby Helder	12
	My Dreams (Tosti), Tenor Solo in English, with orch. accomp., Ruby Helder	12
A5536	Norma (Bellini), "Hear Me, Norma," Soprano and Contralto Duet, orch. accomp., Grace Kerns and Mildred Potter	12
	Sicilian Vespers (Verdi), "Oh, Thou Queen of Love and Beauty," Soprano and Contralto Duet, with orch. accomp., Grace Kerns and Mildred Potter	12
A5538	Te Deum No. 7 in Flat (Festival) (Buck) Orch. accomp., Columbia Mixed Quartet	12
	Morning (Von der Mehden), Orch. accomp., Columbia Male Quartet	12

	DOUBLE-DISC RECORDS.	
A1485	Village Belles (Holst), Prince's Band	10
	Babbling Brook (Rega), Prince's Orchestra	10
A1486	La Belle Helene (Offenbach), Aria, Harp-Zither Solo, Kitty Berger	10
	I and My Boy (Millocker) (I und mei' Bua), Harp-Zither Solo, Kitty Berger	10
A1489	An Old Sweetheart of Mine (Riley), Recitation, Harry E. Humphrey	10
	Me an' Jim, Recitation, Harry E. Humphrey	10
A1493	Faust (Gounod), Soldiers' Chorus, Prince's Band	10
	Souvenir De Valence (Bleger), Cornet Duet, band accomp., Vincent Buono and R. McCann	10
A1499	Che! Que Corte! Matchiche (Grossi), Prince's Band	10
	El Camambu, Mattehiche (Willoldo), Prince's Band	10
A5535	Washington Post March (Souza), Prince's Band	12
	Father of Victory March (Ganne), Prince's Band	12
A5537	Orpheus in Hades (Orphée aux Enfers), (Offenbach), Overture—Part I, Prince's Orchestra	12
	Orpheus in Hades (Orphée aux Enfers), (Offenbach), Overture—Part II, Prince's Orchestra	12

	POPULAR SUCCESSES FOR APRIL.	
A1496	Camp Meeting Band (Muir), Baritone and Tenor Duet, orch. accomp., Arthur Collins and Byron G. Harlan	10
	Buffalo Baby Rag (Reed), Orch. accomp., Peerless Quartet	10
A1494	While the Rivers of Love Flow On (Ball), Tenor Solo, orch. accomp., Arthur Aldridge	10
	As Long as the World Goes Round (H. Von Tilzer), Tenor Solo, orch. accomp., Arthur Aldridge	10
A1497	Do You Take This Woman for Your Lawful Wife? (H. Von Tilzer), Baritone Solo, orch. accomp., William Halley	10
	Don't Blame It All on Broadway (Williams-Young-Grant) orch. accomp., Peerless Quartet	10
A1495	Where Can I Meet You To-night? (Farren and Lange), Soprano and Tenor Duet, orch. accomp., Ada Jones and Henry Burr	10
	Medley of Irving Berlin Hits (Berlin), Prince's Orchestra	10
A1498	Who Will Be With You When I Go Away? (Farrell), Baritone and Tenor Duet, orch. accomp., Arthur Collins and Byron G. Harlan	10
	Good Night, Dearie (Reed), Soprano and Tenor Duet, orch. accomp., Ada Jones and Henry Budd	10

THOMAS A. EDISON, INC.

CONCERT LIST.

28192	(a) Menuett Gb Major (Beethoven); (b) Valse Bluette (Drigo) Violin, piano accomp., Kathleen Parlow	
28193	The Last Rose of Summer, Soprano orch. accomp., Marie Rappold	
28194	The Lawn Swing (Carl Jean Tolman), Contralto and Chorus, orch. accomp., C. Miller and Chorus	

REGULAR LIST.

2210	Hallelujah, Christ is Risen—Easter Anthem (Grant Colfax Tullar), Orch. accomp., Edison Mixed Quartet	
2211	The Bubble—High Jinks (Rudolf Friml) Tenor and Chorus, orch. accomp., Emory B. Randolph and Chorus	
2212	All Aboard for Dixie Land—High Jinks (George L. Cobb) Coon song, orch. accomp., Ada Jones and Chorus	
2213	The Rosary (Ethelbert Nevin), Cornet, orch. accomp., Ernst Albert Couturier	
2214	A Little Love, a Little Kiss (Lao Silésu), Tenor, orch. accomp., Reed Miller	
2215	Favorite Airs from "The Pirates of Penzance" (Gilbert and Sullivan), Edison Light Opera Co.	
2216	Sit Down, You're Rocking the Boat (Jean Schwartz) Comic Song, orch. accomp., Billy Murray	
2217	Cavalleria Rusticana—Siciliana and Intermezzo (Mascagni), American Standard Orchestra	
2218	My Chain of Memories (Mrs. Herbert Ingerham) Soprano, orch. accomp., Beulah C. Young	
2219	Rev. 21:21-25 and The Gate Ajar for Me (S. T. Vail) Scripture Lesson with Hymn, orch. accomp., Madison C. Peters D.D. and Edison Mixed Quartet	
2220	My Love Nell (C. Milligan Fox) Baritone, orch. accomp., E. Gordon MacLean	
2221	Hungarian Fantasia (Theo. M. Tobani), Edison Concert Band	
2222	Sing Me the Rosary (F. Henri Klickmann) Tenor and Chorus, orch. accomp., Irving Gillette and Mixed Chorus	

2223	Lullaby (Chapman) Contralto, orch. accomp., Grace Couch Embler	
2224	I'm Crying Just for You (James V. Monaco) Conversational duet, orch. accomp., Ada Jones and Billy Murray	
2225	The Junk Man, Rag Medley, Banjo, orch. accomp., Fred Van Eps	
2226	Love Divine, All Love Excelling (Sir John Stainer) Soprano and Tenor, orch. accomp., Marie Kaiser and Royal Fish	
2227	Carmen—Toreador Song (Georges Bizet) Baritone, in English, orch. accomp., Alan Turner	
2228	Love Is So Fickle—Waltz Hesitation (Philip Kruseman) For dancing, National Promenade Band	
2229	The Bells—Burlesque (Frank Stillwell) Male voices, orch. accomp., Peerless Quartet	
2230	I'm Crazy 'bout a Ragtime Minstrel Band (Wm. Tracey) Coon song, orch. accomp., Edw. Meeker	
2231	Tango—The Santley Tango (When Dreams Come True) (Silvio Hein) For dancing, National Promenade Band	
2232	The Ragtime Dream (Goodwin and Brown) Coon duet, orch. accomp., A. Collins and B. G. Harlan	
2233	I'm on My Way to Mandalay (Fred Fischer) Tenors, orch. accomp., Albert H. Campbell and Irving Gillette	
2234	You're My Girl Medley—Turkey Trot For dancing, National Promenade Band	
2235	(a) In de Mornin'; (2) Jes' Gib Him One ob Mine (Paul Laurence Dunbar), Reading, Edward Sterling Wright	
2236	The Dear Old Songs (Dox Cruger) Tenor and Chorus, orch. accomp., W. Oakland and Chorus	
2237	Pastel-Menuet (Paradis) Piano, Violin and Violoncello, The Tollfesen Trio	
2238	When the Bloom is on the Cotton, Dixie Lee (J. Fred Helf) Tenor, orch. accomp., M. Romain	
2239	My Old Kentucky Home Fantasia (Otto Langey) Edison Concert Band	

BUFFALO T. M. DEALERS TO ORGANIZE

Expected to Follow Lead of Piano Dealers in That City—Said to Be Badly Needed.

(Special to The Talking Machine World.)

BUFFALO, N. Y., March 10.—Spurred on by the actions of local piano dealers and manufacturers in forming a protective organization, an association of dealers in talking machines and supplies is being contemplated in this city. Thus far the project has only been discussed and no definite actions have been taken in the matter. However, it is likely that before long the organization of talking machine dealers will be realized, as its need is being distinctly felt in this section of the State.

When the organization is formed it will be for the protection of all local dealers in the talking machine trade. This association will, if organized, promote not only the trade in this city, but also in this entire section of the State. It is hoped by local men that the project will be a success.

NEW VICTOR WINDOW HANGER

Designed to Emphasize in Attractive Manner the Testimonial of Richard Strauss.

The Victor Co. has just announced to its trade the publication of a very attractive window hanger presenting a testimonial from Richard Strauss, the celebrated composer, in which he pays a tribute to the musical qualities of the Victor. This hanger is designed in a distinctive manner, showing an excellent portrait of Strauss, together with his praise of the Victor in both German and English. The attention of the trade is called to the fact that Mr. Strauss speaks of the Victor as the gramophone, which is the name by which it is known in Europe.

The text of Richard Strauss' testimonial is as follows: "The gramophone which was demonstrated to me to-day reproduced with approximate perfection, worked faultlessly and was very pleasant in tone and volume of sound, so that I can conscientiously bear witness to the fact that it provided a most delightful treat to a very sensitive ear.—Dr. Richard Strauss."

NEW VICTOR FOLDER.

The Victor Talking Machine Co. has just announced a new folder, showing in detail the complete line of Victrolas, accompanied by adequate descriptions of the various machines. It is the company's intention to introduce in the very near future another folder devoted to the horn types of machines.

The folder featuring the Victrolas is neat and attractive, presenting, in addition to clearly defined cuts of the machines, several pithy selling arguments on behalf of the Victrola. Victor dealers throughout the country are requested to place their orders for this new literature as soon as possible, as there will undoubtedly be a heavy demand for the folders.

\$ \$ \$ \$ \$ \$ \$ \$ \$

\$ \$ \$

\$ \$ \$

\$ \$ \$

\$ \$ \$

\$ \$ \$

READ your trade paper! Get The Talking Machine World regularly—It is worth many times to you its annual cost.

There is but one talking machine paper covering this entire industry, and it is admitted by all that it is of great aid to the dealers in every part of this country.

New economic conditions make certain knowledge necessary on the part of merchants, and in every issue of The World there is contained educational matter, instructive service, business news and technical articles which are worth many times the cost of the paper.

Thousands have been benefited by the business articles which appear in The World, and every talking machine dealer should receive it regularly.

The only way to do that is to pay for it, and the cost is trifling—a little over eight cents a month, and for that small sum The World, with all its mine of information, is at your service.

If you do not receive the paper regularly, just put your dollar in an envelope and address it to the office of the publication, and you will say that it is the best investment that you have ever made.

Do not delay but send on your dollar now.

Recollect that your competitor is getting The World—getting it regularly, and in it he is securing some valuable pointers—information which places you at a disadvantage if you do not read the paper.

Do not overlook such a valuable contributing factor to your business success.

EDWARD LYMAN BILL

PUBLISHER

373 Fourth Avenue,

New York City



Consider the wide range of models that are offered in the Edison line, consider that the Edison line includes both Disc and Cylinder types, consider the fact that for the first time it brings the whole field of vocal and instrumental music into any home, add to these considerations the name of Thomas A. Edison and then ask yourself what else you can demand of a line of phonographs.

Thomas A Edison

INCORPORATED

59 Lakeside Ave., ORANGE, N. J.

The TALKING MACHINE WORLD

AND
NOVELTY
NEWS

Published Each Month by Edward Lyman Bill at 373 Fourth Avenue, New York, April 15, 1914



The best-known trade mark in the world

“The Victor talking machine’s design, ‘His Master’s Voice,’ has become a household word, and the quaint little fox terrier at attention before the horn is familiar to more Americans than any of the world’s great masterpieces”—*Collier’s Weekly*.

Leading Jobbers of Talking Machines in America

Landay
BROS INC.

VICTOR JOBBERS Exclusively
What you want always in stock

400 Fifth Avenue
27 W. 34th Street
563 Fifth Avenue
153 W. 42d Street

New York

1856 WURLITZER 1914

VICTOR
DISTRIBUTERS

VICTORS EXCLUSIVELY

We make a specialty of getting the order out on time—every time.

The Rudolph Wurlitzer Co.
CINCINNATI and CHICAGO

Two points of supply; order from the nearer.

CHASE & WEST DES MOINES IOWA

Machines Records Cabinets **Victor** Everything in stock all the time.

WHOLESALE TO IOWA TRADE

Send us your name and address and we will mail you postpaid complete illustrated catalogues, giving detailed information concerning all Victor products. Showing the various styles of Victor Machines, list of all Victor Records, the entire line of Victor Cabinets, Repair Parts and all Accessories. Dealers, let us help you build a Victor business.

PERRY B. WHITSIT L. M. WELLER

PERRY B. WHITSIT CO.,

213 South High Street, Columbus, Ohio.

Edison Phonographs and Records **JOBBERS** Victor Talking Machines and Records

OLIVER DITSON COMPANY

Largest VICTOR Talking Machine Distributors East of Chicago.

Creators of "The Fastest Victor Service." Let us tell you more about our service.

BOSTON

W. J. DYER & BRO.
Saint Paul, Minn.

VICTOR & EDISON
Distributors

Quick Service for all points in the Northwest. Machines, Records, Supplies.

VICTOR DEALERS TRY US FIRST

We carry the Largest Stock of VICTROLAS, RECORDS and CABINETS of any Distributor in the South.

THE CORLEY COMPANY, Richmond, Va.



Where Dealers May Secure

COLUMBIA
Product

Ready, Full Stocks, and Prompt Deliveries from Convenient Shipping Centers all over the United States.

Distributors

Atlanta, Ga., Columbia Graphophone Co., 132 Peachtree St.
Baltimore, Md., Columbia Graphophone Co., 305-307 North Howard St.
Birmingham, Ala., Columbia Graphophone Co., 1818 Third Ave.
Boston, Mass., Columbia Graphophone Co., 174 Tremont St.
Buffalo, N. Y., Columbia Graphophone Co., 622 Main St.
Chicago, Ill., Columbia Graphophone Co., 14 N. Michigan Ave.
Cincinnati, O., Columbia Graphophone Co., 117-119 W. Fourth Ave.
Cleveland, O., Columbia Graphophone Co., 913 Euclid Ave.
Dallas, Tex., Southwestern Talking Machine Co., 1403 Main St.
Denver, Colo., Columbia Stores Co., 505-507 Sixteenth St.
Detroit, Mich., Columbia Graphophone Co., 114 Broadway.
El Paso, Tex., Southwestern Talking Machine Co., Stanton and Texas Sts.
Hartford, Conn., Columbia Graphophone Co., 719 Main St.
Indianapolis, Ind., Columbia Graphophone Co., 27 N. Pennsylvania St.
Kansas City, Mo., Columbia Graphophone Co., 1112 Grand Ave.
Lincoln, Nebr., The Grafonola Company, 1036 O St.
Livingston, Mont., Scheuber Drug Co.
Los Angeles, Cal., Columbia Graphophone Co., 420-422 S. Broadway.
Louisville, Ky., Columbia Graphophone Co., 425 South Fourth St.
Milwaukee, Wis., Albert G. Kunde, 516 Grand Ave.
Minneapolis, Minn., Columbia Graphophone Co., 424 Nicollet Ave.
New Haven, Conn., Columbia Graphophone Co., 25 Church St.
New Orleans, La., Columbia Graphophone Co., 933 Canal St.
New York City, Columbia Graphophone Co., 89 Chambers St.; Columbia Graphophone Co., 35-37 W. 23d St.; Columbia Graphophone Co., 39 W. 125th St.
Philadelphia, Pa., Pennsylvania Talking Mach. Co., 1109 Chestnut St.
Pittsburgh, Pa., Columbia Graphophone Co., 101 Federal St.
Portland, Me., Columbia Graphophone Co., 550 Congress St.
Portland, Ore., Columbia Graphophone Co., 371 Washington St.; Eilers Music House.
Providence, R. I., Columbia Graphophone Co., 119 Westminster St.
Rochester, N. Y., The Grafonola Company, 38 South Ave.
Sacramento, Cal., Kirk, Geary & Co.
Salt Lake City, Utah, Daynes-Beebe Music Co., 45 Main St.
San Francisco, Cal., Columbia Graphophone Co., 334 Sutter St.
Seattle, Wash., Columbia Graphophone Co., 1311 First Ave.; Eilers Music House, 3d and University Sts.
Spokane, Wash., Columbia Graphophone Co., 818 Sprague Ave.
Springfield, Mass., Columbia Graphophone Co., 174 Worthington St.
St. Louis, Mo., Columbia Graphophone Co., 1008 Olive St.
St. Paul, Minn., Columbia Graphophone Co., 17 East Sixth St.
Tampa, Fla., Tampa Hardware Co.
Terre Haute, Ind., 640 Wabash Ave.
Toledo, O., Columbia Graphophone Co., 229 Superior St.
Washington, D. C., Columbia Graphophone Co., 1210 G St., N. W.

DEALERS WANTED—Exclusive selling rights given where we are not actively represented. Write for particulars to the Columbia Graphophone Co., Wholesale Department, Woolworth Building, New York.

Headquarters for Canada:
Columbia Graphophone Co., 363-5-7 Sorauren Ave.
Toronto, Ont.

SANGER BROTHERS
Dallas, Texas

VICTOR
Distributors

"We ship the same day."

Southern Victor Dealers
Largest Stock VICTROLAS and RECORDS. Prompt Shipment and Low Freight Rates.

WALTER D. MOSES & CO.
Oldest Music House in Virginia or North Carolina.
RICHMOND, VA.

Edison Phonograph Distributors
for the SOUTHWEST

All Foreign Records in Stock

Houston Phonograph Co., HOUSTON, TEXAS

NEW ENGLAND
JOBGING HEADQUARTERS
EDISON AND VICTOR
Machines, Records and Supplies.

THE EASTERN TALKING MACHINE CO.
177 Tremont Street BOSTON, MASS.

PACIFIC COAST DISTRIBUTORS OF
Victor Talking Machines and RECORDS

STEINWAY PIANOS—LYON & HEALY
"OWN MAKE" BAND INSTRUMENTS

Sherman, Clay & Co. San Francisco Portland Oakland Los Angeles

The Chicago Edison Jobber

The perfection of Musical Instruments—THE EDISON diamond disc PHONOGRAPH—with EDISON double disc records.

THE PERFECTION OF SERVICE—Our Service.

The Perfection of advertising for the dealer—Our plan.

The Phonograph Company
229 So. Wabash Ave. CHICAGO

Every Jobber in this country should be represented in this department. The cost is slight and the advantage is great. Be sure and have your card in the May List.

The Talking Machine World

Vol. 10. No. 4.

New York, April 15, 1914.

Price Ten Cents

GRAND OPERA IN ATLANTA.

Engagement of the Metropolitan Opera Company Booms Talking Machine Sales in Gate City—Fifth Engagement Under Auspices of the Atlanta Music Festival Association.

(Special to The Talking Machine World.)

ATLANTA, GA., April 6.—Although it is some weeks before the Metropolitan Opera Co. stars will make their Southern flight, Atlanta and indeed the whole South is centering its attention on the seven performances that will be given beginning the evening of April 27 and closing the evening of May 2.

The operas to be given are: Massenet's "Manon," "Il Trovatore," "Der Rosenkavalier," "Un Ballo in Maschera," "Madame Butterfly," "Lohengrin," "Cavalleria Rusticana," "Pagliacci."

Indications point to the largest attendance and the most successful engagement that has yet been filled, and already the seating capacity of the immense Auditorium is taxed to its utmost.

The local talking machine dealers are experiencing great benefit from the coming engagement and the sale of grand opera records and talking machines has been very much stimulated.

M. Rich Bros. & Co. are giving recitals from the opera on each Friday afternoon, using the Grafonola grand for playing the records, and at the first recital given on the afternoon of March 27 the recital room was filled to overflowing. The recital is accompanied by explanatory readings and a brief outline of the stories of the different operas.

Beginning with Tuesday, April 7, each evening the Cable Piano Co. will give in its Victrola rooms similar recitals of the opera with interpreted readings by Miss Dora Hood, one of the best known musical critics in the South and also a talented elocutionist.

In lighter vein there is one thing that stands out alone, "dance music." They buy it in person, they send for it by the children, they write for it, telephone for it and even telegraph for it. We tango the first thing in the morning, before meals, after meals, between meals and the last thing at night. No, the talking machine dealer doesn't worry. He simply plays "Too Much Mustard" on his cash register and offers a fervent prayer that their shoes and energy will not wear out.

INNOVATION IN CHURCH SERMONS.

Phonograph Used in Place of Minister for Delivery of Sermon—Creates Quite a Sensation and Wins Most Favorable Comment.

(Special to The Talking Machine World.)

SPOKANE, WASH., April 4.—An innovation in church services in this city was the phonograph sermon at the Bethel Presbyterian Church, Seventh avenue and Sherman street, last Sunday night. Owing to the church being without a pastor the phonograph occupied the pulpit, taking the place of the regular evening sermon.

The phonograph sermon, which was preached for phonograph use by the Rev. Dr. Wm. H. Morgan, of Pittsburgh, Pa., was greatly enjoyed by the congregation, an intense silence prevailing throughout its delivery.

The phonograph used was the Edison Amberola V loaned by Mr. Nat Dumphy, of the Graves Music Co., of this city.

Moving pictures have been used in some churches, but the phonograph sermon is the latest. It has been used in other cities with great success, and judging from the way it was received here it will be utilized more frequently in local churches.

One price! The fixed, uniform, fair price is the one strong protection of the small dealer against his big competitors who can afford to slaughter prices to control trade. Price-cutting in its essence is in restraint of trade. Let Congress make note of this fact.

TELEGRAMS AS TRADE DEVELOPERS.

Suggestion That Live-Wire Dealers Could Reap Considerable Benefit from Timely Display of Telegrams in Show Windows—How Idea Can Be Utilized in Divers Ways for Publicity.

It was suggested recently by a prominent talking machine man that live-wire dealers could reap considerable benefit from the timely display of telegrams in their show windows. In connection with this idea it is interesting to note that a manufacturing firm in the Middle West recently sent out a series of telegrams to its dealers dealing with appropriate bulletins or messages of interest that it deemed the dealer could utilize to profitable advantage. Accompanying this series of telegrams the firm sent out the following explanatory letter: "The psychological effect of a telegram is too well known to explain here. We have made inquiry of a number of our agents to whom during the last month we have sent out telegraphic bulletins on the small regular telegraph blanks such as are furnished by the telegraph companies. Those dealers who displayed these telegrams in their windows have been so enthusiastic over the results achieved that we have decided to send you regularly a telegram similar to the one enclosed. Paste this, with the stickers provided for the purpose, in your window and watch the crowds stop and read. It will draw people, and once you get them in your store it's up to you."

There is undoubtedly sound logic to this letter, as there is a certain attractive influence attached to telegrams that make a peculiar appeal to the general public. It is probably curiosity that is the most powerful factor in this attitude, but whatever it may be, it attracts crowds to the dealer's show window and this in itself is excellent publicity.

The talking machine dealer can utilize this telegram idea in divers ways. For example, he can simply give instructions to his distributor to wire him at frequent intervals regarding some new record or some particular feature of a forthcoming or just issued supplement of new records. As soon as these telegrams are received the dealer should paste them inside his window, not with care of position as if by design, but in a careless, off-hand manner that will appear natural and unstrained. These telegrams will surely attract passers-by and prove an excellent publicity medium.

HERE'S A LIVE "TALKER" DEALER.

(Special to The Talking Machine World.)

WEST PALM BEACH, FLA., April 9.—The recent visit to this hustling city of Maud Powell, the famous violinist, was turned to good advantage by Frank Idner, an aggressive and up-to-date Victor dealer. Mr. Idner as soon as he learned of Miss Powell's visit to West Palm Beach trimmed his window along artistic and attractive lines, featuring Maud Powell and her excellent records in the Victor library.

In addition to this show-window, Mr. Idner mailed a postcard to each person attending Miss Powell's concert, showing a splendid portrait of Miss Powell, together with a partial list of Victor records corresponding with the evening program. This timely and appropriate publicity had its desired effect as Mr. Idner closed many sales of Maud Powell records, in addition to securing the names of several live machine prospects.

THINGS NECESSARY TO SUCCESS.

To know every detail, to gain an insight into each secret, to learn every method, to secure every kind of skill, are the prime necessities of success in any art, craft or trade. No time is too long, no study too hard, no discipline too severe, for the attainment of complete familiarity with one's work and complete ease and skill in doing it. As a man values his working life, he must be willing to pay the highest price of success in it—the price which severe training exacts.—H. W. Mabie.

OPEN ATTRACTIVE DEPARTMENT.

The Rhodes-Mahoney Furniture Co., Victor and Columbia Dealers in Chattanooga, Tenn., Has Handsomely Arranged Quarters—Large Attendance on the "Opening Day."

(Special to The Talking Machine World.)

CHATTANOOGA, TENN., April 5.—With the opening of the new talking machine department of the Rhodes-Mahoney Furniture Co. to-day, one of the most complete, best arranged and most attractive departments in the South was created. The Rhodes-Mahoney Furniture Co. has long been one of the most prominent Victor and Columbia dealers in Tennessee, and with its new quarters and improved facilities for handling stock and for demonstration purposes there is no question that its already large business will experience a gratifying increase. On the opening day the rooms were tastefully decorated with immense vases of pink and white carnations and the walls banked with beautiful ferns. From 2 to 6 o'clock the patrons of the department were entertained by a recital on the Grafonola grands and tea was served to several hundred visitors who called to inspect the new department and to congratulate members of the firm and Manager Neece on the opening of the new booths.

One of the features of the day was the playing of the first Columbia double-disc record by Oscar Seagle, the brilliant young baritone, himself a native of Chattanooga. The selections, "Prologue from Pagliacci" and the famous "Drinking Scene from Hamlet," were well received by Mr. Seagle's fellow townsmen.

PHONOGRAPH GETS GIRL CONTRACT

At the La Scala Opera House in Milan—Prodigy Discovered by Bonci During His Visit to San Francisco—Had Records of Her Voice Made from Which Engagement with Italian Opera Company Resulted.

Charmed with the voice of a young girl which they have heard only as produced by a phonograph record that has been sent to Milan, the management of the world-famous La Scala Opera House has by cable offered her a contract to sing in grand opera there.

The girl, who is only eighteen years old, is of Italian parentage, and comes from San Francisco. Her name is Iole Pastori, and she was discovered with her brother singing in the streets of the Golden Gate City by Alessandro Bonci, the renowned tenor, during his visit there some time ago. Mr. Bonci was greatly impressed with the wonderful natural coloratura voice of the young singer, and sent for her. He questioned her and made her sing for him everything that she knew. The result was that Bonci pronounced the child as destined to be one of the greatest prima donnas the world has ever known.

He succeeded in getting a wealthy Italian resident of San Francisco to agree to defray the expense of the child's musical training and brought her to this city, where he placed her under the tuition of Mme. Valeri. The progress the girl has made in her vocal and musical studies has been remarkable, and a month ago Bonci had her make several records for the Columbia Phonograph Co. One of these records, the "Caro Nome" from "Rigoletto," was sent to the managing director of La Scala, and when he heard it he promptly cabled an offer of a contract.

The girl herself has sung for Caruso, Toscanini and Gatti-Casazza, of the Metropolitan Opera House, who all declare that she is a marvel. It is predicted that she will make a sensation when she appears in Milan.

WILL JOB TRITON PHONOGRAPHS.

A. M. Fiske has been appointed State jobber for New Jersey for the Triton Phonograph Co., 41 Union square, New York.

HOUCK'S DANCE EXHIBITION CAUSES SENSATION.

The O. K. Houck Piano Co., Victor Distributer in Memphis, Tenn., Engages Two Professional Dancers for Window Exhibition, in Which the Latest Dances Were Exploited to the Music of the Victor, Arousing the Greatest Possible Interest.

(Special to The Talking Machine World.)

MEMPHIS, TENN., April 5.—The O. K. Houck Piano Co., the successful Victor distributor of

The crowds grew from day to day until Saturday night, when they put on an extra and special performance between 7 and 9 p. m., and that evening the crowd was so large that it extended all the way from the window across to the pavement on the opposite side of the street, and once or twice the regular policeman on the block had to move the crowd to let the cars pass by.

Saturday afternoon there was a strong counter attraction for about 30 minutes. A man drove by in his automobile and was so much interested in the dancing that he inadvertently turned into the street car, resulting in the dismantling of his machine, but did not do any very serious injury to himself or the street car.

The company expects to place this attraction



Dancing to Victor Music in O. K. Houck Co.'s Window.

this city, which has on a number of occasions put over advertising stunts that have made Memphis sit up and take much notice, capped the climax last month when the company arranged to have two of the best amateurs in Memphis illustrate the various new fashioned dances in one of the large show windows of the company's store each afternoon for a week. The exhibitions lasted two hours each day and the repertoire of dances included the following: One-Step, Two-Step, Turkey Trot, Horse Trot, Lame Duck, Tango, Memphis Tango, Waltz, Waltz Boston, Waltz Hesitation, Hesitation a la Memphis, and Maxixe.

The couple danced three, four or five minutes; then retired to a small dressing room and remained there until some of the crowd moved on. In order to keep their identity unknown, both the lady and the gentleman wore wigs and masks.

In order to eliminate any chance of having the sixteen foot glass in the front window broken, a carpenter built a very substantial wooden rail all around the front of the window, and, as a further safeguard, the company had the Commissioner of Police detail two of the best looking and best dressed policemen, who were on guard every minute during the two hours' entertainment.



Crowd Around Window to See Dances.

for a week's engagement at its Nashville Store and another week at its Little Rock Store, and these two engagements will be followed by one in our Concert Hall in Memphis, which will accommodate about 150 people, and the dancing will be done on the stage.

At one time it was rumored that the genial O. K. himself was to illustrate the Boardwalk Limp direct from Atlantic City and a flock of the belles of the city headed for the Houck Co. store with hearts fluttering and ambitious to be selected as dancing partner for one of the most prominent and eligible bachelors in Memphis. Mr. Houck didn't come across with the dance, however, and the result is that he will probably stay single for some time to come at least.

MAKES RECORDS OF BIRDS' VOICES.

Thomas A. Edison, Upon Return from Vacation in Florida, Brings Most Interesting Collection of Records of Birds' Songs—Secures Special Record Carrier.

Thomas A. Edison, who returned to his home in Orange a few days ago, after a sojourn of several weeks with his family at Fort Meyer, Fla., brought back with him a unique and most interesting collection of records of birds' voices. Mr. Edison is a bird lover, as well as his companions on his vacation—Henry Ford, the automobile man, and John Burroughs, the aged naturalist.

Several weeks ago they set out in the underbrush of the Florida Everglades a number of machines which could be set in motion by a push button a mile away. These were for the purpose of catching the songs of the shy swamp birds. The experiment was successful, and scores of strange bird songs were obtained.

To bring them back Mr. Edison will use a new record-carrier which he invented while away and was made at West Orange from his written specifications. It will also be used in the future for the transportation of delicate records so that they will not crack or chip.

The carrier consists of an iron receptacle, which is fur-lined. The records are placed in this, with soft rubber between them. Then they are screwed down compactly and pneumatic coverings are placed over the top and bottom so that the records cannot move in any direction.

TO CONTINUE THE BUSINESS.

The Pooley Furniture Co., bankrupt, has made application through its receiver, M. Weinmann, to be permitted to continue the business for five months, or until such time as it may be turned over a going business, under pending negotiations. In this way it is estimated the best results will be secured for the creditors, as the sale of the property at this time would be disastrous.

The Success Of Your Talking Machine Department

Is to a *large* extent dependent upon the service your distributor gives you.

This admitted makes it important that you secure the best service obtainable.

AND THAT IS EASTERN SERVICE

To use it is to swear *By* it not *At* it.

May we not have the opportunity to convince you that our service is exceptional?

EASTERN TALKING MACHINE COMPANY

177 TREMONT STREET, BOSTON, MASS.

EDISON

FOR NINETEEN YEARS TALKING MACHINES EXCLUSIVELY

VICTOR

The foremost dancing authorities endorse the Victor and Victor Records



Mr. and Mrs. Vernon Castle, teachers and greatest exponents of the modern dances, use the Victor exclusively, and superintend the making of their Victor Dance Records.

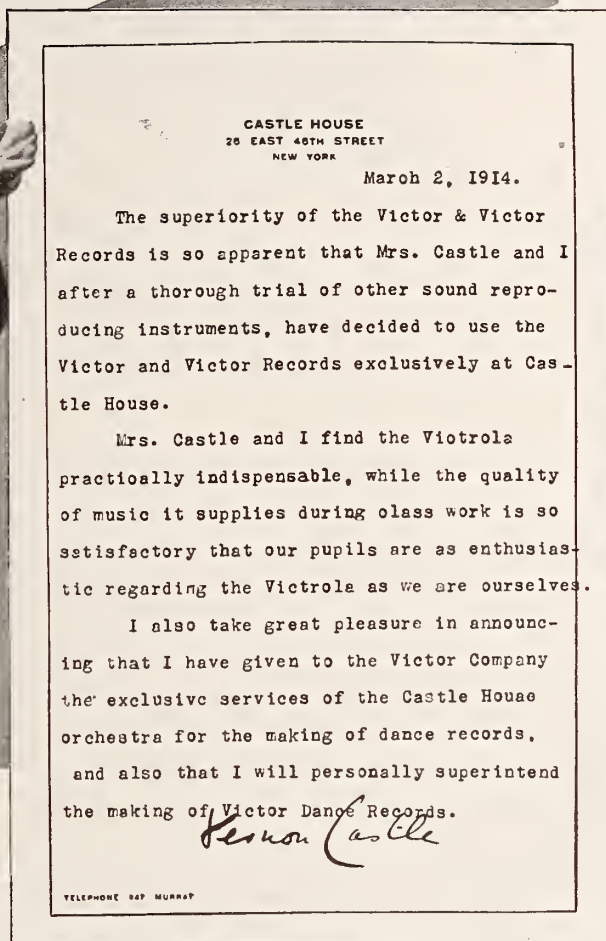

Further evidence of why the Victor is the world's greatest musical instrument—another important asset for every Victor dealer.

Victor Talking Machine Co., Camden, N. J., U. S. A.

Berliner Gramophone Co., Montreal, Canadian Distributors

Always use Victor Machines with Victor Records and Victor Needles—the combination. There is no other way to get the unequalled Victor tone.



FAMOUS RECORD ALBUMS

AT VERY LOW PRICES TO MEET COMPETITION

For Durability, Artistic Design and Finish, our Albums have no equal. They are made in the most substantial manner by skilled workmen.

Our Albums are first-class in every particular, and are sold at very low prices.

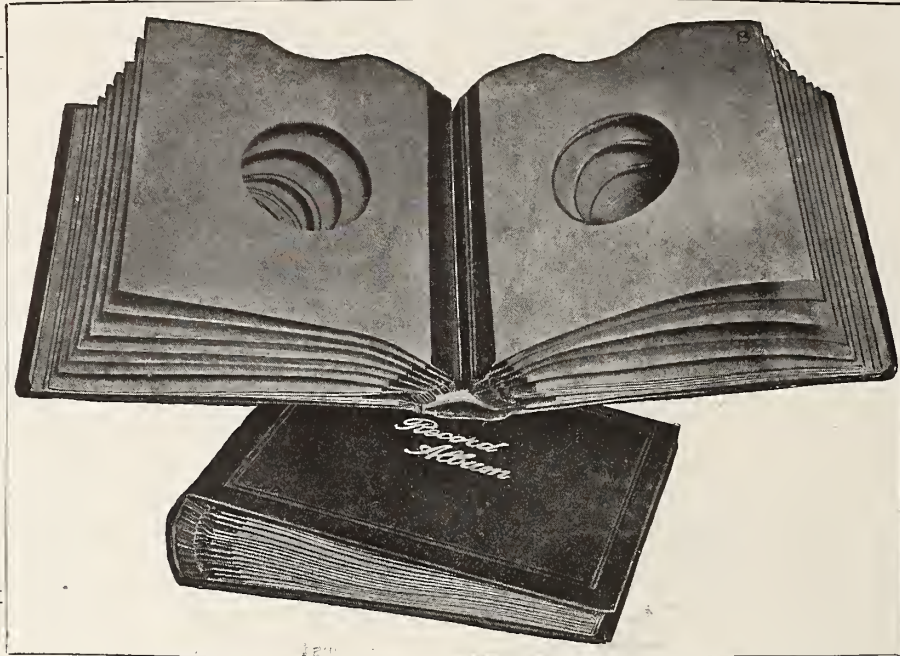

OUR SUPERB ALBUMS SHOWN OPEN AND CLOSED.

MADE IN TWO SIZES TO FIT ALL 10 AND 12-INCH DISC RECORDS.

These Albums contain 17 pockets made of strong fibre paper, each pocket having a hole in the center, as shown in the picture. These pockets are so made that they show very plainly both the single and double face titles on the Records. The Albums are bound in the finest quality of Brown Silk Finish Cloth, with gilt title on front cover. They are also bound in imitation leather. Write for sample and prices of our Albums, which are superior to all others.

Address NATIONAL PUBLISHING CO., 235 South American St., Philadelphia, Pa.

TRADE HOLDS ITS OWN ON THE PACIFIC COAST.

Two Weeks of Grand Opera Stimulate Interest in Operatic Records—No Falling Off in Demand for Dance Records During Lent—New Quarters for the Pacific Phonograph Co. and Also for Babson Bros.—Columbia Co. Expansion—Other Items of Interest.

(Special to The Talking Machine World.)

SAN FRANCISCO, CAL., March 31.—Talking machines seem to have held their own remarkably well the past month, in view of the fact that general business was rather slow here during March. The extreme hot weather the first half of the month, when the thermometer registered higher than it has been in March in the San Francisco Bay district for twenty-two years, was not conducive to great activity in retail business, especially when school children were enjoying spring vacations and a good many families were out of town. However, complaints about business did not emanate from talking machine quarters in many instances. Two weeks of grand opera stimulated interest in operatic records, and no great falling off in the demand for dance records has been noted during Lent. As evidence that the talking machine business here is in a healthy state, two houses have announced their intention of moving to more desirable quarters within the next few weeks.

Leases Quarters in the Sachs Building.

The Pacific Phonograph Co., of which A. J. Pommer is proprietor, has taken a lease on a large floor space in the Sachs building in Geary street, which is a modern structure centrally located, with excellent shipping facilities, as well as special elevator accommodation and other features of importance in connection with a jobbing business in talking machines. Mr. Pommer will occupy the entire third and fourth floors of the building with his Edison business, and will have them fitted up in first class shape for occupancy at an early date. He says orders came in in satisfactory volume from the travelers the past month.

Babson Bros. to Move.

The other move already referred to happens to

be an Edison proposition also. New quarters have been secured at 235-237 Geary street for the local branch of Babson Bros., which afford much better facilities than their present location at 65 Post street. The Geary street store is to be thoroughly renovated before occupancy, and will be fitted up as modern phonograph parlors, with special accommodations for the demonstration of the disc products. The move will take place some time in May.

Conditions with Columbia Co.

The local headquarters of the Columbia Graphophone Co. were visited the past month by E. E. Robinson, representative of the Columbia Co., on his way to New York after a year in the Orient. Coast Manager W. S. Gray has been making short visits to near-by points the past few weeks, and reports Columbia dealers in very good spirits generally. He has just returned from San Jose, where conditions are especially favorable in view of the prospects for unusually heavy crops in the Santa Clara Valley, which suffered greatly last year from lack of moisture. Mr. Gray is devoting considerable attention now to preparations for the Columbia exhibit at the exposition. He has received preliminary plans for the display, which, if carried out, will undoubtedly make a splendid showing.

Medium-Priced Machines Popular.

F. Anglemier, local wholesale manager for the Columbia Graphophone Co., says country trade has kept up in fine shape the past month. Dealers in the Bay cities have also ordered quite freely, bringing up the totals for the month to a satisfactory figure. He notes a particularly strong demand for the \$75 and \$100 machines, and finds the demand for dance music on the increase.

Prominent New Columbia Agents.

W. S. Gray closed a deal with the Weil Furniture Co. at Modesto, Cal., recently to handle Columbia

goods in that district, and he considers the company in position to give the line very good representation. He says talking machines and furniture are being featured together quite extensively now with very good success. The Sonoma Valley Furniture Co. at Santa Rosa, Cal., took on the Columbia line also a short time ago.

Expansion in San Jose.

The Columbia department of the Madsen Furniture Store in San Jose, Cal., has been greatly improved. It has been given more floor space on the second floor of the establishment, and a manager has been appointed to devote his entire attention to that part of the business. He is A. L. Hascall, who has been connected with the business in another capacity for several years. He is a Columbia enthusiast, and has already inaugurated Thursday night concerts and other special features to get the people interested. Mr. Hascall was a recent visitor in San Francisco.

LECTURED ON "THE MESSIAH."

Great Oratorio Explained with Aid of Victrola by Rev. Henry R. Ross.

(Special to The Talking Machine World.)

NEW BEDFORD, MASS., April 8.—The Rev. Henry R. Rose, a prominent clergyman of this city, has been giving an interesting lecture on "The Messiah" before the leading clubs and organizations of New Bedford at which he uses the Victor Auxetophone in connection with a stereopticon to illustrate the lecture. His lecture has attracted the attention of the leading newspapers of this city who have commented on it at length, paying particular attention to the important part that the Auxetophone plays in the success of the lecture.

A salesman should never cease studying the possibilities of his goods. He should know them from start to finish; everything connected with their manufacture. In this manner he will gain knowledge and confidence in his line, and knowledge in any line is power.

PROCESS FOR ENLARGING AND REDUCING DISC RECORDS

The Invention of M. Georges LeRoy, Director of the Chemical Laboratories of the City of Rouen, France, Interestingly Described—Of Exceeding Importance to All Engaged in the Manufacture of Records—Technique of the Process Set Forth in Detail.

A new, original and ingenious process for enlarging or reducing the size of disc talking machine records, the invention of M. Georges LeRoy, director of the chemical laboratories of the city of Rouen, France, is described as follows by R. Arapu in a recent issue of the Scientific American:

Phonograph records, i. e., the traces made on wax discs or cylinders by the needle of a recording phonograph, can be enlarged or reduced by the following physico-chemical process, without the aid of the pantograph, by which such reproductions have hitherto been made exclusively. In the first place it should be observed that the new process is superior to the pantographic method because it excludes the employment of levers and other mechan-

attained the desired size it is made insoluble by immersion in a solution of formol, and is then molded in wax or plaster. From the wax or plaster mold is made a galvanoplastic copper matrix, or master record, with which the working records are stamped. The diameter of the soft gelatine disc can be tripled by immersion, and the enlargement can be increased indefinitely by repeating the process on gelatine copies of the enlarged plaster or copper matrices.

For reduction the copper plate made from the primary wax record is used to produce a copy in weak gelatine, containing 10 to 25 per cent. of dry gelatine, which is dehydrated by immersion in dilute alcohol, a solution of sodium sulphate or of

Rochelle salt, by exposure to a current of dry air, or by the action of a vacuum desiccator. The gelatine record, thus contracted and reduced, is copied successively in wax or plaster and in copper, in the manner described above. The diameter of the gelatine disc can be contracted to 60 per cent. of its original value, and the reduction can be continued indefinitely by contracting gelatine discs made from the reduced copper plates. In the accompanying photograph No. 2 represents an original record of 120 millimeters diameter, No. 1 a reduction to 80 millimeters, No. 3 an enlargement to 190 millimeters, and No. 4 a second enlargement to 340 millimeters.

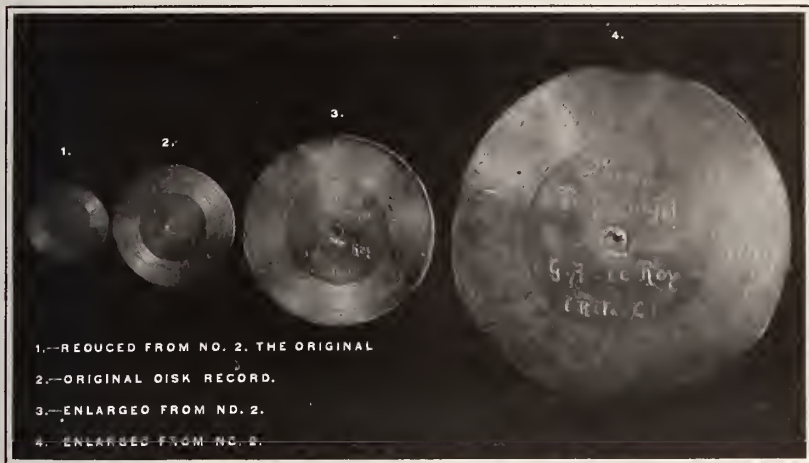

How a Talking Machine Record May be Magnified or Reduced in Size

1. Shows a reduction to 80 millimeters diameter. 2. The original record of 120 millimeters. 3. An enlargement to 190 millimeters. 4. A second enlargement to 340 millimeters.

ical organs, which inevitably affect the record by means of their own vibrations and reactions. On the other hand, the record may be improved by employing the new process. In current practice, the primary wax record is made by means of sounds of exaggerated loudness in order to produce a strong impression, and injurious secondary vibrations are thus evoked and recorded. By the new process a record made with tones of moderate intensity, free from disturbing secondary vibrations, can be enlarged until it produces tones as loud as may be desired. Conversely, a record made with loud tones can be reduced, and thereby softened, in addition to being compressed into smaller compass.

Principle of the Process.—The enlargement is effected by the dilatation of molds of the primary record, made of material which is greatly dilated by prolonged immersion in appropriate solutions; for example, gelatine immersed in aqueous solutions, or vulcanized rubber immersed in carbon disulphide. Conversely, the reduction is effected by the contraction produced in similar molds by appropriate treatment, as by the desiccation of a mold composed of highly hydrated gelatine.

Technique of the Process.—From the primary wax record a copy is made in copper by galvanoplasty. For enlargement a mold of this copper record is made in a concentrated solution of gelatine, containing 30 to 50 per cent. of dry gelatine. The gelatine mold is immersed in cold or tepid water, pure or containing substances that promote the expansion of the gelatine. When the mold has

WHY THE SALESMAN WORRIES.

Often Forced to Use Quick Wit in Understanding Customers' Translation of Names.

Quick wit in selling a customer is exemplified by a salesman in California who was approached by an intelligent customer asking for a record called "Pork and Beans." After thinking a moment, without saying a word or expressing any surprise, the salesman asked his patron to be seated. Then as he went to rear of the store to get the record he bethought himself of which record it might be. In a flash it dawned upon his memory. "Ciribiribin—that's it," he said to himself. (Pronounced Cheer-ee-beer-ee-bee-an.) The name suggested the nickname, "Pork and Beans." Then he looked up the catalog number (1,825), put the record on the cylinder machine and played it. It filled the customer's expectations, and was sold. Then another record was asked for and sold, says the Edison Phonograph Monthly. Now that customer always asks for Mr. Schwartz because she gets intelligent service. The clerk is to be commended for his quick wit and for his acquaintance with the list.

SPECIAL LECTURE-CONCERT

Given by Mrs. Erwin Craighead in the Grafonola Parlors of the Smith Piano Co., Mobile, Ala., Attracts a Large and Fashionable Audience of Local Music Lovers.

(Special to The Talking Machine World.)

MOBILE, ALA., April 3.—During the past month the Smith Piano Co., one of this city's leading piano houses, has been conducting an energetic campaign on behalf of its talking machine department that has produced excellent results. This company handles the products of the Columbia Graphophone Co. in this department, and has been cultivating a clientele that would appreciate the musical worth of Columbia operatic and semi-classic records.

To properly introduce this class of music the company issued invitations to a select list of this city's music lovers inviting them to attend a special lecture-concert given by Mrs. Erwin Craighead in the company's Grafonola parlors. Mrs. Craighead's concert was a marked success, and the lecture she delivered on the musical beauties of Columbia records proved a treat.

To further increase the sales possibilities of its operatic record department, the company also sent out a four-page folder giving a few pocketbook arguments on the excellence of Columbia opera records. A feature of this circular was the listing of a number of the famous artists whose recordings for the Columbia Co. have met with emphatic success. These operatic and concert stars included Emmy Destinn, Olive Fremstad, Alessandro Bonci, Leo Slezak, Mary Garden and many others.

INTERESTING PRIZE CONTEST

Inaugurated by the Voice of the Victor for the Best Talk on the Victor.

An interesting prize contest in the nature of three original talks on Victor records was announced recently in the "Voice of the Victor," the house organ of the Victor Talking Machine Co. The first prize in this contest will be \$20, the second prize, \$15, and the third prize, \$10.

The contest is open to all Victor dealers and salesmen or saleswomen and was conceived so that the members of the selling staffs of the Victor dealers could exercise their knowledge of the Victor library in describing any chosen Victor record. There is no limit to the number of words that the competitor may use in this contest, but is suggested by those in charge of the contest that from two to three hundred words should prove sufficient for an excellent descriptive story. It is also suggested that the competitor assume that he is talking with a prospect and wished to present a particular record interestingly and informatively. The results of this contest will be announced in the May issue of the "Voice of the Victor."

SINGER HEARD 125 MILES.

Successful Test from Brussels to Paris of New Wireless Telephone.

An interesting experiment in wireless telephony was made between Brussels and the Eiffel Tower in Paris one night last week, when by a new microphone invented by Signor Marzi, an Italian engineer, a tenor singing at Laeken, a Brussels suburb, could be heard in the French capital.

The shrill notes were clear, but the words were indistinguishable. The distance is about 125 miles.



The Columbia automatic stop. The most accurate automatic stop made and the easiest to operate.

Gun Metal, \$2.00 list. Nickel Plated, \$2.50 list. Gold Plated, \$3.00 list.

May be adjusted to both Columbia and Victor disc machines. Order from any Columbia Distributor.



LOUIS XVI

Model A450, Circassian
Walnut, \$450.00

Model A400, Mahogany,
\$400.00



SHERATON

Model A275, Ma-
hogany, Inlaid
Plain, \$275.00



Model A80, Mahogany,
\$80.00

Three Edison Salesmen want jobs with you today

Tone, Variety and Mechanical Excellence are three Edison Salesmen that your customers can't get away from.

Edison Sweet Tone is *Head* Salesman—don't forget that. The others help but *Tone* makes the sale.

Then *Variety* steps in with *three* convincers—prices for every purse—*two* types of machines—eight distinct cabinet designs in Disc Phonographs alone.

Mechanical Excellence closes, and he's able to close on *any* feature—Blue Amberol Records, Diamond Reproducer, Diamond Disc or New Motor. Whether he signs them up for a \$250 Diamond Disc Cabinet or an Edison Gem at \$15 you'll say his is a snap job.

Put all three of these salesmen to work for you—*to-day*.

Thomas A. Edison, Inc.



Model A200, Mahogany
and Oak, \$200.00



Model A300, Cir-
cassian Walnut,
\$300.00



SHERATON
Model A290, Mahogany, Inlaid Marquetry, \$290.00

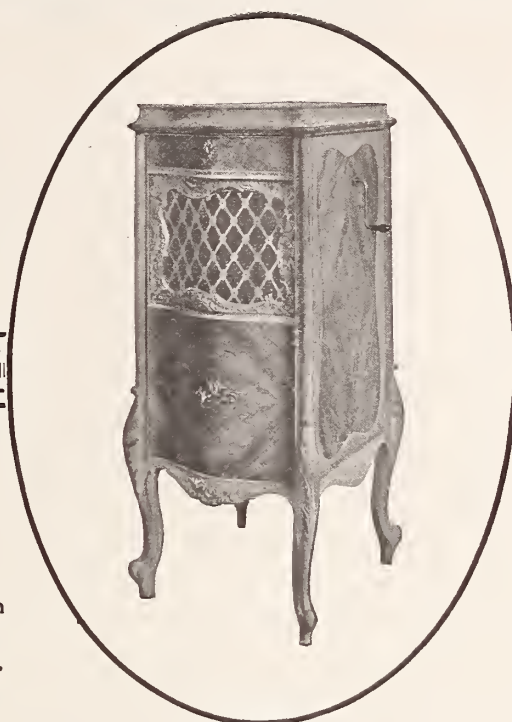

LOUIS XV
Model A425, Circassian Walnut, \$425.00
Model A375, Mahogany, \$375.00

These are the Points that sell Edison Goods

- (1) No bothersome needle to be constantly changed.
- (2) Diamond Disc Phonographs alone can render *everything* in the world of music.
- (3) Diamond Disc Phonographs alone reveal the overtones.
- (4) Diamond Disc Phonographs alone have the diamond reproducing point that never wears and the New Disc that is never worn.
- (5) Diamond Disc Phonographs have the New Motor of constant speed that gives a perfect, constant pitch.
- (6) Blue Amberol Cylinder Records play 4 minutes—are renowned for the sweetness and great volume of their tone.
- (7) There is an Edison Phonograph of a type, finish or price to suit everyone who comes into your store.

Talk over the complete Edison Line with your jobber. Send him word *to-day*.



Model B60, Oak, \$60.00

59 Lakeside Ave., Orange, N. J.



Model A250, Mahogany and Oak, \$250.00



Model A150, Mahogany and Oak, \$150.00

QUANTITY ORDERS FOR STANDARD BIG SELLERS

Should Be Placed by Dealers Who Desire to Keep Ahead of Record Demand, Says V. W. Moody in Discussing Record Situation—Reasons Why Many Dealers Have Not Sufficient Stock on Hand to Fill Substantial Percentage of Their Record Business.

In connection with the tremendous scarcity of Victor records at the present time, there is no doubt but that many Victor dealers have realized that the placing of their record orders must be in accord with current conditions, and instead of ordering two or three records of a number several times in the month they have placed one large single order, knowing that they can easily dispose of the shipments of this number as based on the factory output at the present time. Many other Victor dealers, on the other hand, have not given due consideration to this feature of their business, but have continued along as in former years, with the result that they have no stock to fill a substantial percentage of their record business.

To the latter dealers the recent remarks by V. W. Moody, sales manager of the New York Talking Machine Co., 81 Chambers street, New York, one of the best known Victor distributors in the country, should prove of particular advantage and interest.

"Many of our dealers are ordering records to-day along the same lines as they did a year or even six months ago," said Mr. Moody. "They are ordering the exact same quantities, and in accordance with their methods of some time since, are placing orders for one of a certain selection, regardless of how good it may be. They are even ordering the same selection eight or ten times a month, just as they have in the past. But to-day, on account of the tremendous record shortage, the dealer who is doing any considerable amount of business is working at a serious disadvantage and is badly handicapping himself by ordering in that way.

"Last week we received an order from a dealer who is selling over \$30,000 worth a year. His order covered three closely written pages and totaled about 350 records. He had ordered certain records in quantities of one to five apiece, according to the record's popularity. Realizing the situation in the record field, we had our representative make a special trip to this dealer in order that he might explain the status of the Victor record business to him and impress upon the dealer the necessity of ordering along the proper lines, emphasizing the following points:

"Because of the extreme record shortage the majority of Victor distributors are out of the same selections and, due to this fact, each distributor is receiving requests from numerous dealers who ordinarily would have called on some other distributor to fill their orders. This means that when

the distributor receives a quantity of a popular record, sufficient ordinarily to last him about ninety days, they are disposed of within a few hours, because of the multiplied dealers' requests and the fact that all dealers are in need of that particular number.

"To a large extent we anticipated tremendous record sales this spring, and in December and January ordered accordingly, and these orders are being shipped by the Victor Co. in small quantities almost daily. We have received as high as 2,000 of a single dance number, which, by the way, was issued last year, and disposed of them all within less than twenty-four hours, whereas the sales of this same number last year averaged about 300 a month with us. This particular lot of records was received on Tuesday at 2 p. m. In other words, this means that the dealers' orders for this number that were received on Monday and up to noon Tuesday were *not* filled. The entire lot was sent out by noon on Wednesday and therefore, even had the dealer followed out a system of ordering small quantities three times a week he would not have received any of this particular number. Moreover, we had had none of this number in stock for more than a month previous and have received none since.

"In view of the foregoing the absolute necessity of ordering large quantities of the standard big sellers is apparent, and the necessity of 'back-ordering' these numbers is even more obvious. By back-ordering we mean the placing of a general order for records with instructions to ship such numbers as are in stock at that time and transferring the unfilled portion to be shipped as rapidly as deliveries from the factory will enable the distributor to make shipments to the dealers in sufficient quantities to justify transportation charges.

"Our Mr. Doty was the representative who made the special trip to the dealer referred to above, and the morning following his visit we received this dealer's revised order, which was condensed to a single sheet instead of three, and totals 3,465 records instead of the 327 records on the original order. Since that date we have shipped this dealer large quantities of such popular numbers as 17,222, 17,231, 17,311, 35,295, 35,304, 35,346, 64,311 and 64,343, and we shipped enough of these records to last him several months."

Here Mr. Moody remarked to the representative of The World, "As you continue on your rounds suppose you just ask the dealers and distributors that you call on what the condition of their stock

is on these numbers and the service we are rendering this dealer will be fully appreciated.

"Just think of the amount of work that the dealer incurs in ordering the same numbers over and over again, where he might better order the numbers once, lay aside his empty envelopes, mark them 'ordered' and forget them until the distributor receives factory shipments which will fill up the holes in the dealer's stocks. Few dealers realize that distributors are receiving twice as many records from the factory as ever before. This fact is overlooked because the distributor is out of so many numbers. Many dealers are complaining because of the 'horrible condition that exists,' but it is not difficult to make most of them smile by inducing them to admit that they are doing the biggest business they have ever closed, and asking them what it is they are selling if they are not receiving more stock than ever before.

"The Victor Co. is not to be blamed, neither is the distributor, nor is the dealer, but it is the public who is to be most severely criticised. It seems impossible to satisfy the public. It is the consumer who loudest of all is shouting 'records, records, records and more records,' and I wonder if the dealers or distributors or the Victor Co. would be pleased to hear them stop shouting just that very thing. I know that I would not."

NOVEL PLAN OF WINNING BUSINESS.

Louis Gilman, Eastern representative of the Philadelphia Press, tells Printers' Ink how he obtained some Edison business for his paper by means of a phonograph record sent by parcel post to the advertising department of Thomas A. Edison, Inc., Orange, N. J.

Mr. Gilman explains that for the day on which the Edison business was to be placed he had an engagement with a client in Pittsburgh. As he couldn't be in both places, Mr. Gilman dictated a solicitation to his machine and sent the record to L. C. McChesney, advertising manager of Thomas A. Edison, Inc.

The Press secured some of the Edison business and the "canned" solicitation is credited with having obtained it.

HAS WON HOST OF ADMIRERS.

Admirers of Lucretia Bori, the remarkably clever soprano of the Metropolitan Opera House, and they are legion, will be delighted with her latest Edison records. She is represented by three double records in the disc line and one in the Blue Amberola catalog. Miss Bori has scored a phenomenal success during the opera season now coming to a close.

When a man gets old enough to take advice and wise enough not to give it, he isn't on earth to profit by either.

The DITSON Pledge

Is to see that our clientele has a better service than ever—setting a new standard in Victor jobbing deliveries. The demands of alert Victor dealers—the kind that grow—are many and varied, and we furnish the "first-aid" in every instance.

We believe this year's Victor business will be of tremendous proportions, and it will pay you to have

The Fastest Victor Service

which is a requisite in this hustling age. We possess the largest stocks, the best organization and most up-to-date equipment in the Eastern half of the country.

This covers Victor machines, records and supplies of every kind, not to mention cabinets, needles and trade-marked accessories.

Will you let us tell you more about Ditson co-operation? A postal gets this information!

OLIVER DITSON CO., Boston, Mass.



Much of the success of Columbia opera recording is due to the personal interest of Mr. Henry Russell, director of the Boston Opera Company.



(Write for "Music Money," a book "full of meat" for those dealers interested in quick and frequent turnover of capital.)

Columbia Graphophone Company
Woolworth Building, New York

CREDITORS TAKE CHARGE OF BUSINESS OF J. ARNOLD

Take Step to Protect Their Own Interests Following Financial Difficulties of Cincinnati Talking Machine Dealer—Ill-Health Largely Responsible—General Trade in Cincinnati Very Good—Record Sales Heavy—What the Various "Talker" Houses Have to Report.

(Special to The Talking Machine World.)

CINCINNATI, O., April 7.—During the past week creditors of John Arnold, talking machine dealer at Fifth and Elm streets, took charge of their stock and in that manner closed out the business of this dealer. The action is the outcome of a series of misfortunes which have befallen Arnold, and it probably leaves him penniless, without even his homestead exemption.

Arnold has been laboring under difficulties for months. Illness at his home, then located in Hyde Park, took up a greater part of his capital. Besides looking after his business, Arnold tried to nurse his wife back to health. The two conditions resulted in his becoming a nervous wreck, and he was compelled to leave his affairs in the hands of an employe at his store. Developments show that Arnold did not make the necessary arrangements to protect his affairs. No instructions were given to any of his friends, and it is intimated that not even the creditors knew of what was transpiring.

After Arnold left town suit was brought to foreclose on a mortgage on his home. He placed this matter in the hands of an attorney but did not confide anything about his business. Notes which were due the latter part of last month could not be taken up, and it is asserted that those who made an investigation found that no books were kept nor a bank account existed during the absence of Arnold. The Kipp-Link Co., of Indianapolis; the Phonograph Co., Cleveland, and the Rudolph Wurlitzer Co., this city, were the principal creditors. The amount of their losses could not be learned. The firms simply stepped in and closed out the business. One business man intimated that failure on the part of Arnold to establish a more confidential relation with the houses that he did business with brought about the drastic steps. The difficulties of Arnold were intimated in this column several months ago. Arnold is now at Denver trying to recover his health. So far as is known, he has not taken any steps towards a future career. He is still a young man.

While the individual reports would indicate an exceptional business yet, in a general way, the trade suffers from the general condition of the labor market. There have been a few repossessions. The smaller houses are holding their own. The large firms are bothered with a shortage of records, which has proven a serious handicap to the trade at a time it needs the most encouragement.

One of the features of the local market during the past month was a monthly display at the Columbia store favoring the \$35 Grafonola. Small cuts, showing a reproduction of the instrument, were pasted on the window, forming a border. The case contained several "Jewels" and a bunch of records. It was a neat combination and an attractive talking machine display.

When Manager Whelen, of the local Columbia store, was asked the usual stereotyped question,

"How is business?" he said: "The sale of records seems to have been the principal feature of our business this past month. I personally believe that this wonderful stimulus is due to the dancing craze, and the craze becomes more pronounced each week. Perhaps one-half of the records sold are dance records, and when you consider that the demand for the other class of records has not diminished; in fact, has increased, you can get some idea of just how good this end of the business is. Never in the history of the Cincinnati store has the demand been so great, and I tell you it kept us humping some checking in shipments to keep our racks even partly up to date. This wonderful record business also stimulates the machine business and on a whole March was a record breaking month. If we had had twice as much room and double the number of booths there were many times every day when we could hardly handle the trade. It looks like a case of 'everybody's doing it.'" Mr. Whelen concluded by saying: "We get similar reports from all over the territory, and during the last month we have opened up some very attractive accounts and added many new names to our list of dealers."

Mr. Brown, the assistant manager of the local Columbia store, who has been specializing on the school proposition, says that he is more than satisfied with increase in the school sales and has closed quite a few competitive trials, winning out in every case on the merits of the Columbia instruments for school purposes.

One month has passed at the Rudolph Wurlitzer Co. without carpenters and other members of the building fraternity pounding away making changes in the talking machine department. Manager Dittrich has summarized the situation in the following interesting manner:

"The month of March was very good in spite of the bad weather conditions, but as the conditions this year are so infinitely better than last year there is absolutely no complaint to make in that respect. Last year at this time the Ohio Valley was under water and many dealers were absolutely ruined financially. To-day these dealers have prosperous stores, and are enjoying a greater volume of business than they have ever had before. Reports from throughout our territory indicate that the Victrola business is in splendid condition, although the shortage of records has caused some loss of trade. However, the retail consumers have taken very kindly to the dealers' explanation as to the cause of the shortage, and it has impressed every one with the vast growth of the Victrola business and the tremendous future which is in store. The shortage has accomplished one thing, and that is it has proven to the dealer that there are other records besides the selected list which are known as the best sellers. In that way it has proven a vast benefit to the talking machine trade at large." Victor business picked up with a rush at Aeolian Hall during the past

two weeks, the most gratifying feature being the large sale of the most expensive styles and the amount of cash taken in. In fact, the percentage of cash sales during the month was about the largest on record.

A very large increase of business is looked for immediately following Easter, when the dancing season, interrupted by Lent, will be resumed.

A great deal of special sales effort was put forth at Aeolian Hall the past few weeks. The Victor department is unquestionably at its highest point of efficiency right now. The company is undoubtedly making good on its "Aeolian Victor Service," which is so much advertised.

Aeolian Victor advertising has not slackened one iota because of ante-Lenten dulness. On the contrary, the store has used more newspaper space on the Victrola and Victor records than ever before and results have been perfectly satisfactory.

TAKE ON EDISON DISC LINE.

(Special to The Talking Machine World.)

SAN FRANCISCO, CAL., April 6.—Clark Wise & Co. have added the Edison disc line and are featuring it quite extensively as well as Victor and Columbia goods. Mr. Wise says business has kept up better in the talking machine department since the first of the year than pianos.

J. T. Bowers & Son, who took the agency for the Edison disc line a short time ago, are now pretty well stocked. Heretofore they had confined their attention to pianos, but F. T. Bowers is very well pleased with the interest shown in the new department. He made a pleasure trip to Honolulu the past month, accompanied by his wife and an Eastern piano manufacturer and his wife.

If the whale were a more persistent advertiser he wouldn't get in so bad. As it is, he comes up to blow about himself, and gets the harpoon.



Write today for our new catalogue giving you rock bottom prices of our specialties.

Springs for any kind of Talking Machines

No doubt you will find it interesting.



EMIL RIEDEL

Sächsische Sägen- u. Federstahlwaren-Fabrik.

Chemnitz-Gablenz, P. O. Box 10, Germany

The **TALKING**
For the **MACHINE**
makers & **WORLD**
sellers of
talking
machines

EDWARD LYMAN BILL, - - - Editor and Proprietor.

J. B. SPILLANE, Managing Editor.

Trade Representatives: GLAD. HENDERSON, C. CHACE, L. E. BOWERS, B. BRITAIN WILSON, A. J. NICKLIN, AUGUST J. TIMPE, L. M. ROBINSON.

Boston: JOHN H. WILSON, 324 Washington Street.

Chicago Office: E. P. VAN HARLINGEN, Consumers' Building, 220 South State Street.
 HENRY S. KINGWILL, Associate. Telephone, Wabash 5774.

Philadelphia: R. W. KAUFFMAN.

Minneapolis and St. Paul: ADOLF EDSTEN.

San Francisco: S. H. GRAY, 88 First St.

Cleveland: G. F. PRESCOTT.

St. Louis: CLYDE JENNINGS.

Cincinnati: JACOB W. WALTER.

London, Eng., Office: 2 Gresham Buildings, Basinghall St. W. LIONEL STURDY, Manager.
 Representatives for Germany and Austria: VERLAG NEC SINIT, Berlin C. 19, Ross-Strasse 6, Germany. GEO. ROTHGIESSER, Director.

Published the 15th of every month at 373 Fourth Ave., New York.

SUBSCRIPTION (including postage), United States, Mexico, \$1.00 per Year; Canada, \$1.25; all other countries, \$1.75.

ADVERTISEMENTS: \$3.00 per inch, single column, per insertion. On quarterly or yearly contracts a special discount is allowed. Advertising pages, \$100.00.

REMITTANCES: should be made payable to Edward Lyman Bill by check or Post Office Money Order.

NOTICE TO ADVERTISERS.—Advertising copy should reach this office by the first of each month. By following this rule clients will greatly facilitate work at the publication headquarters.

Long Distance Telephones—Numbers 5982-5983 Madison Sq.
 Cable Address: "Elbill," New York.

NEW YORK, APRIL 15, 1914

A YEAR ago a great section of the Middle West was just recovering from one of the worst floods ever experienced in this country. The receding waters had left wreck and ruin behind. Scores of towns suffered losses of life as well as staggering property losses, and many business houses were placed in a very serious position by reason of the staggering losses endured.

In fact, it was a very serious condition, and many, in viewing the flood-swept districts, figured that business would suffer in those localities for years to come; but such is the recuperative powers of Americans that in the very sections where business interests seemed to have been most seriously affected trade has been particularly brisk, and it serves to illustrate that Americans lose no time in bemoaning what they have lost.

There is no use in losing time in bewailing past conditions and business losses, because "the mills will never grind with water that is passed." It is the active present and ambitious future which interests the men of to-day.

And sometimes adversity brings out the best that is in a man.

Some of our great business leaders all graduated from the University of Hard Knocks, and while they received some good heavy blows, they were not of the down-and-out class. They possessed courage and were resourceful.

Many a man has been developed by reverses. His best qualities probably would not have been brought out under ordinary conditions.

It, however, is to be hoped that the courage of the men in the flood-devastated districts of 1913 may not be put to the test in a similar manner for at least a long time to come.

THE talking machine men are getting to understand more and more the benefit of advertising. Surely they have the best kind of examples constantly before them in the publicity campaigns carried on by the great manufacturers.

Advertising has made the talking machine business, and there is no question that if the great national campaigns were abandoned in six months business would slump very materially, notwithstanding the tremendous impetus which it now has. The directors of the great enterprises fully understand the advantage of this, and the dealers themselves, even in the smaller districts, are waking up to the fact that they must do their share in the great campaign. They are putting out advertising, some of which is most attractive.

THE advertising field is constantly changing. Years ago advertising smacked of dishonesty—of misrepresentation; in fact, much of the public exploitation was simply to lure people into the stores and strip them of their money after they had arrived.

To-day, however, the successful business man tells the truth in his advertising, else he is not successful.

If a man tells an untruth in advertising he is quickly found out.

In New York there has been a lot of dealers in various lines who have misrepresented in their advertising, and some of the daily papers have refused to carry the announcements of such concerns, knowing that they misrepresented.

How a man must feel to be turned down by a newspaper because he has gained the reputation of being a dishonest advertiser!

So far as talking machines are concerned, a man is advertising a single product, and one that has individual advertising powers. It talks for itself, to use the colloquial saying; but there are so many attractive ways to put forth advertising matter, so that it is pleasing to observe that the dealers themselves are advancing along lines of public exploitation.

WE are in constant receipt of communications from readers of The Talking Machine World in every part of the universe expressing their admiration and approval of the policy of this paper, and its power as a constructive force in the industry.

It certainly is very pleasing to note the approbation of a widespread clientele of readers, and it shows that our policy has been appreciated and has received the stamp of universal approval.

We have always contended that a trade paper must be constructive in its work, else its true functions would be lost. That The World is a splendid advertising medium is generally conceded.

We have received letters from advertisers commending the business building powers of this publication, and below is one received recently from the New York Talking Machine Co., 81 Chambers street, New York, large and important Victor distributors:

"We wish to express our entire satisfaction with the service rendered us by you in the last issue of The Talking Machine World advertising our record cabinets. We have received many nice responses and a number of orders for cabinets and envelopes, together with a large number of inquiries from good, substantial dealers who read the advertisement.

"Kindly accept our compliments on the pulling power of your organ. It is not alone a good advertising medium, but, in our opinion, a good, live root of the talking machine industry."

That communication shows what a power The World is to the jobbers, and yet there are but few jobbers out of the entire list who avail themselves of the splendid opportunities which The World presents for the exploitation of their wares.

Every talking machine jobber in this country should be represented in every issue of The Talking Machine World.

It is the only publication which thoroughly and completely reaches the small dealers as well as the large ones. It is working for them day and night. It not merely aids the dealers, but makes suggestions to them along advanced lines, so that it is a constructive power of virility and strength.

Now it would seem as a natural sequence that the jobbers themselves should appreciate, as a whole, the advantage of such a publication, and not permit a few men to monopolize the business opportunities offered by the paper.

If the talking machine jobbers of America desire such a paper as The Talking Machine World—and they all admit its strength—then the next question that logically comes up is why should they not patronize its columns to a greater extent?

WE are desirous that The World shall be close to its readers everywhere, and we shall be pleased to receive at any time either criticism or comment from our readers, no matter where located.

If there are any paths which we can make smoother by suggestions we shall be pleased to do so. In other words, The World is the forum of the trade, and all are invited to enter as close as they like into a discussion of matters of interest and business importance.

The closer a trade paper comes to its constituency the more aid it can be to them, provided it is fairly conducted, and unless it performs a useful mission it is missing its opportunity, and we do not care to miss any opportunities which may come to us in any particular way to serve our constituency in a better manner.

THERE is no part of America, so far as we are able to learn, where the dance craze has not appeared, and talking machine dealers are asking if the abnormally large demand for dance records is to continue.

Why should it not?

Old men and women have joined the youthful army of dancers, and the talking machine is used by teachers of the art all over this country.

The tango mania has certainly created new business, not only for dance records but for the machine themselves, because a new profession has sprung up and dancing teachers now have regular studios where machines are installed and are almost swamped with people who are anxious to be taught the art.

Here is a new and astonishing field developing, and it does not look as if it would be temporary.

Talking machine dealers write us that it is difficult to keep up with the demand for dance records, and the factories are rushed to the utmost, and they cannot keep up with the orders that the new tango mania has brought about.

In thousands of homes where the talking machine was only used at intervals, to-day it is being used daily and nightly to

produce music for an ever increasing army of family dancers.

It certainly has developed the demand not only for records, but for machines in every part of the land.

IN the January issue of The World a remarkable offer was made of a \$250 outfit by the Columbia Graphophone Co. to The World reader who would suggest the best method by which closer and more profitable relations might be enjoyed with talking machine customers. This offer resulted in bringing in hundreds of communications embodying suggestions from every part of the country.

This Columbia move is along the lines of business uplift which is decidedly commendable. It means that on the part of the Columbia Co. there is a definite effort to get in closer touch with their dealers, seeking to get from them an expression of opinion as to how their interests could be served in a manner which would result in more profitable business.

The reward offered was simply made with the purpose of drawing out opinions from the men who are on the firing-line, and for opening up ideas which might help in a general distributive plan.

It may be said that many valuable suggestions have been received and while it is not possible to put them all into practice, yet many of them are being put into use so far as practicable.

The advantage of this kind of work will be seen when we understand that this offer did not apply exclusively to Columbia dealers, but to everyone in the talking machine trade.

There is no reason why we should follow out certain business plans simply because they may have been in use for a number of years. The whole world is changing and men change their business organizations to conform with this change.

The talking machine industry is young. It has much to learn and an interchange of ideas is bound to bring out some thought along advanced lines which will be for the benefit of all.

GIVE DANCING EXHIBITION.

Illustration of Latest Dances in Recital Hall of Fulton Music Co. Store, at Waterbury Conn., Attracts Much Favorable Attention—Victrola and Edison Disc Phonograph Featured.

(Special to The Talking Machine World.)

WATERBURY, CONN., April 4.—The Fulton Music Co., the prominent piano and talking machine house of this city, which recently occupied its handsome new building at 158-162 Grand street, created a distinct sensation late last month by arranging for the appearance of Miss Lesley L. Hyndes and her partner, Elton Goldsmith, in a complete repertoire of the latest dances.

The dancing exhibition took place in the recital hall of the Fulton Music Co.'s building on Saturday afternoon and the dance music was furnished by a Victrola and an Edison disc machine phonograph. An impromptu concert filled in the intermissions between the dances and afforded an opportunity for the featuring of the latest records. Admission was free to the public, and as a result the recital hall was crowded to capacity by an audience of over three hundred people.

During the course of the afternoon Miss Grace

Gaylord, of Waterbury, and Kendrick Brown illustrated some of the latest society dances.

So successful was the first dancing exhibition that the Fulton Music Co. was compelled to repeat the feature the following Saturday for the benefit of those who were unable to attend the first performance, and the effect of the novelty upon the sale of dance records was immediately apparent.

BACK TO THE SOIL FOR MUSIC.

South Carolina Paper Claims That by Producing Denatured Alcohol from Potatoes and Farm Waste the Farmer Really Makes Talking Machines Possible.

Everything comes to the farmer these days. Even the new dances promise to pay him tribute. The popularity of these dances has created enormous demand for phonograph records of dance music. Now phonograph records are made out of a composition into which denatured alcohol largely enters, and the demand for it is causing manufacturers to look around for new sources of supply. This according to the Charlotte, N. C. Observer, means new locations for factories. But denatured alcohol is strictly a farm product, be-

ing made from potatoes and farm waste. And so it comes to pass that the farmers exert themselves to produce a larger supply of some of the ingredients of denatured alcohol, in order that more phonograph records may be manufactured, in order that more people may have music to which they may dance the new dances—which many a farmer holds to be an abomination.

HELPFUL IDEAS FOLLOW EACH OTHER

The results obtained by Victor dealers from the distribution of the lithographed folders entitled "Will you open your door" and "Will there be a Victrola in your home this Christmas," were so highly satisfactory that the Victor Co. has just issued a third lithographed folder named "After dinner introduce your guests to," the inside double page showing a beautiful scene in many colors wherein a Victrola XVI is the center of attraction in the drawing room of a fashionable home while a distinguished party of guests is present. This is the same drawing which has been reproduced by the company for use in national advertising. This folder forms a valuable addition to the comprehensive line of Victor folders already issued.

Beka Records

IN ALL LANGUAGES OF THE WORLD

High grade selections in

German, English, Italian, Spanish, Portuguese, French, Swedish, Slavonic, Ruthenian, Danish, Norwegian, Russian, Polish, Hungarian, Bohemian, Rumanian, Tschechisch, Croatian, Servian, Hebrew, Turkish, Persian, Arabic, Chinese, Malay, Japanese and seventeen different Indian dialects.

The cheapest and best machine on the market for \$2.50 upward

BEKA-RECORD AKT. GES., Berlin, S. O. 36 (Germany)

CATALOGUE IN FOUR LANGUAGES SENT FREE ON REQUEST



Each buyer and each seller of a Columbia "Favorite" is always satisfied—the one with the quality, the other with the profit.



(Write for "Music Money," a book "full of meat" for those dealers interested in quick and frequent turnover of capital.)

Columbia Graphophone Company
Woolworth Building, New York

BIG BOOST GIVEN THE TALKING MACHINE BUSINESS

By the Southern Indiana Teachers' Association in Indianapolis—Acknowledge Its Educational Value in the School Room—E. L. Lennox Piano Co. Takes on Edison Disc Line—Stewart Co.'s Great Victor Business—Columbia Activities—Other Items of Interest.

(Special to The Talking Machine World.)

INDIANAPOLIS, IND., April 8.—Talking machine men of the Hoosier capital are still rejoicing over the boost given the talking machine business by the Southern Indiana Teachers' Association at its annual convention here, when it went on record as favoring talking machines and player-pianos.

Use of the talking machine in bringing direct to the schoolroom the voices of the master singers of the world was advocated. Men who have made a life-long study of bringing learning to the pupil in the most direct manner asserted before the convention that the talking machine is a modern step in the education of the young of Indiana.

Talking machines are being used in the schools all over the State, both for the purpose of entertainment and for the purpose of studying the voices of the great singers.

Walter E. Kipp, president of the Kipp-Link Phonograph Co., jobbers for the Edison machines, has won over E. L. Lennox, of the E. L. Lennox Piano Co., 311 North Pennsylvania street. Mr. Lennox is the first downtown piano dealer to put in a line of the new Edison disc machines. Praise for the new Edison disc has been heard often in the Lennox showrooms in the last week.

The E. L. Lennox Piano Co. occupies artistic quarters in the Meridian Life building just opposite University Park, and Mr. Kipp is happy over the acquisition of the Lennox store as one of the downtown depots for the new Edison disc machine. Mr. Kipp says he is making arrangements to have two or three other downtown houses put in the Edison disc line of talking machines.

W. S. Barringer, of the Stewart Talking Machine Co., distributors of Victor machines, says the line of orders waiting to be filled are so far ahead of the stock that everybody around the Stewart house is afraid to look back. It's the same old story with the Stewart Co.—it's got that Oliver Twist appetite for talking machines and records.

Morley Somers, of the Victor Talking Machine Co., is working in Indiana for a few weeks.

Business conditions with the Columbia Graphophone Co.'s local store at 27 North Pennsylvania street, are also way beyond "par," according to A. W. Roos, manager. Business so far this year has been about three times as good as it was in the same period of last year, Mr. Roos says.

Morris Stegner, in charge of the wholesale department of the Stewart Talking Machine Co., recently made an extended trip through the South.

Mrs. Agnes Kimball-Affleck, formerly of Indianapolis, who has made a number of records for

COLUMBIA GRAND AIDS AT BANQUET.

Affords Pleasing Entertainment at Banquet of Department Heads of Butler Bros. to Their Manager—Diners Express Appreciation.

"I wish to thank you personally for the use of this beautiful instrument which did a great deal toward making the evening a complete success. It fitted in very beautifully with the evening's entertainment and was appreciated by every one present."

That's what Daniel D. Osttost said to R. R. Souders, who had lent a Columbia "Grand" to help along the festivities at a recent banquet given by the department heads of Butler Bros., in Dallas, Tex., to A. M. Mason, their manager, who recently returned from a European trip.

AGAIN IN HARNESS.

Chester Beekman, of the traveling staff of the New York Talking Machine Co., 81 Chambers street, New York, Victor distributor, resumed his work on Wednesday of last week, after a month's absence from his territory pending his convalescence from an operation for appendicitis. Mr. Beekman was given a hearty welcome.

the Victor Co., sang in public for the first time since she was married last December, when she appeared Tuesday night, March 31, in Aeolian Hall here.

Many were unable to see the singer, since their seats were on the stairways and the floors above and below the concert hall. It was a genuine "over-flow" meeting. B. F. Traub played the concert numbers for the instruments and the accompaniments for the singer. Mrs. Affleck's pure, clear soprano voice was at its best as she sang "Belletella," from "Il Pagliacci." For her second group of songs Mrs. Affleck selected "Down in the Forest," the "Mattinata," by Leoncavallo, and lastly, another ballad by Ronald, composer of "Down in the Forest."

The management of the Aeolian Co.'s local store here has asked Mrs. Affleck to appear at an invitational concert in one of the city's larger auditoriums, that all of her friends may have the opportunity to attend.

ENTHUSIASTIC VICTOR YOUNGSTER.

(Special to The Talking Machine World.)

HARRISBURG, PA., April 9.—O. F. Baker, energetic Victor dealer in this city, numbers among his best patrons one of the youngest Victrola enthusiasts in this section of the State and probably in the country. His name is Harvey Beaumont, and although he is but fourteen years of age, he is the personal owner of a Victrola and an extensive library of Victor records, including quite a number of Red Seal selections. The machine and records have all been purchased from his own savings, and Harvey makes several trips a month to Mr. Baker's store to keep in touch with the latest developments in the Victor record library. His enthusiasm in the Victrola is unbounded, and, moreover, he is a real music lover.

TO MAKE AND SELL PHONOGRAPHS.

The Cumberland Royal Phonograph Co., Portland, Me., has been incorporated with capital stock of \$250,000 for the purpose of manufacturing and dealing in phonographs, records, etc. The officers of the new company are: T. A. Sanders, president, and R. A. Worth, treasurer.

READY REFERENCE OF GENERAL SUPPLIES

DEALERS

Send for our "Trial Proposition" on the Regina Hexaphone—the latest and best paying popular priced coin-operated instrument for use in public places.



211 Marbridge Bldg., 34th St. and Broadway, New York City
Manufacturers of Regina Music Boxes; Reginaphones;
Coin-operated Mandolin Orchestrons; Vacuum
Cleaners and other specialties.

Mermod & Co.

505 Fifth Avenue New York

Manufacturers of

Talking Machine Supplies

Motors—Sapphire Points

Diamond Points a Specialty

Keep Your Record Stock with



Costs about \$2.00 for 250 records for 50 years
Send for 20-page catalog

THE SYRACUSE WIRE WORKS,
SYRACUSE NEW YORK

BREAKING EVEN—A DIABOLICAL REVENGE.

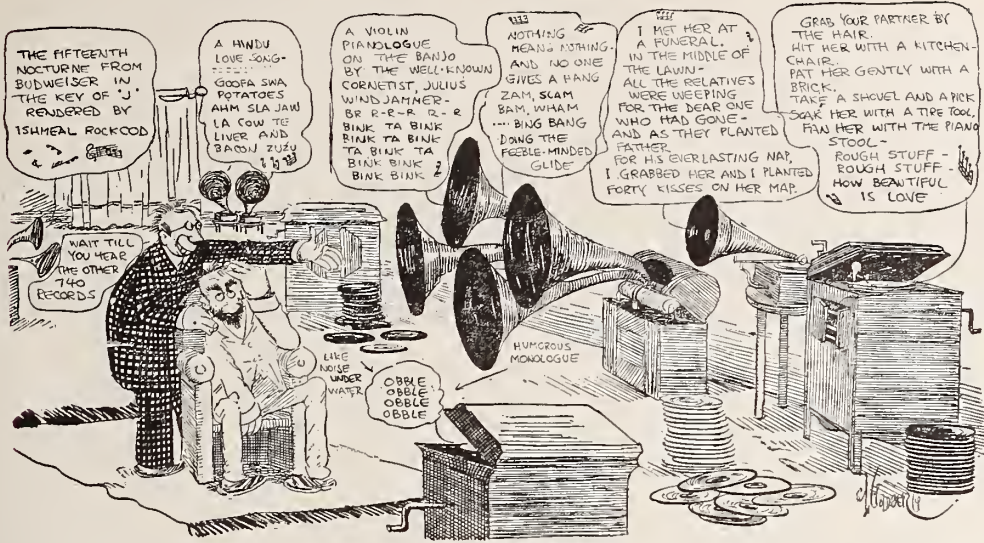

R. L. Goldberg in the New York Evening Mail. (Copyrighted.)

Cartoonist's Idea of How to Get Square With the Man Who Always Starts His Talking Machine as Soon as You Get in the House.

H. B. RAY NEW ADVERTISING CHIEF.

Of the Columbia Graphophone Co.—Experienced in This Field, Having Been Assistant Advertising Manager of the Company for the Past Three Years—Has Assumed Duties.

Herbert B. Ray has just been appointed advertising manager of the Columbia Graphophone Co., New York, succeeding George P. Metzger, who has become a partner in the Hanff-Metzger Co.,



Herbert B. Ray.

New York, a very successful advertising agency. Mr. Ray has assumed his new duties.

Herbert B. Ray has been assistant advertising manager of the Columbia Graphophone Co. for

the past few years, and his promotion to the management of the advertising department is in line with the policy of the Columbia Graphophone Co. to promote men from their own forces to the most responsible positions in all departments. Mr. Ray filled the position of assistant advertising manager with signal ability and success, and his intimate familiarity with all the details incidental to the Columbia Co.'s country-wide advertising insures his achieving a gratifying success in his new and important post. As advertising manager of the Columbia Graphophone Co. Mr. Ray occupies one of the most responsible positions in the company, as the advertising appropriation of the Columbia Co. has steadily increased each year until it now totals an immense sum that is being distributed to the best possible advantage of Columbia dealers throughout the country.

Mr. Ray has been connected with the Columbia Co. for the past fifteen years, occupying various positions of responsibility. Most of this time was spent at the factories in Bridgeport, Conn., where he secured a detailed practical knowledge that he has found invaluable in the preparation of result producing advertising matter.

J. G. BREMNER TO SUPPORT BILL.

J. G. Bremner, president of the Eastern Talking Machine Dealers' Association, is one of those representing trade organizations who will appear before the Interstate and Foreign Commerce Committee at Washington for the purpose of supporting the Stevens Bill (H. R. 13,305), which, among other features, is aimed to prohibit price cutting.

Any new business idea that offers to help a man get more profit out of his business is hailed with welcome—mixed with suspicion of the motives of the man offering it.

NEW COMPANY IN CLEVELAND.

Incorporation of the Grafonola Co. of That City Marks Success of C. A. Routh in the Talking Machine Field—Store Handsome and Well Located in City's Best Business District.

(Special to The Talking Machine World.)

CLEVELAND, O., April 6.—The incorporation of the Grafonola Co. is a good example of a youth starting with ambition and vigor and working up from the lower ranks to be president and manager of a company. C. A. Routh started as a boy working for the Starr Piano Co., of Richmond, Ind., learning action regulating, etc. He left the factory work and engaged in the sales department, and was considered one of the foremost salesmen in the piano line. At that time piano men generally could not see anything in the talking machine business, and Mr. Routh's associates were very much surprised at his going into it. He, however, looked ahead and is now reaping the benefits of his foresight. Mr. Routh had been with the Columbia Co. for some time as assistant manager, and when the company decided to close out its retail business in Cleveland, in his own words, he "immediately saw a great light," and laid his plans accordingly to get control of the old location; the result is that the Grafonola Co. was incorporated, with C. A. Routh, president and manager, and F. S. Federman, secretary and treasurer, with a capitalization of \$15,000.

The Grafonola Co. is handling Columbia goods exclusively, and carries a complete stock of machines, records and accessories. The store is centrally located in the business heart of the city, and is considered the largest retail talking machine store in Cleveland. During Mr. Routh's long association with the Columbia Co. he has made a host of acquaintances and friends, all of whom he will retain and make many more.

GIVES ELABORATE RECITAL.

Fred H. Ponty Features Victrola and Edison Disc Machines and Other Instruments in His Line at Elaborate Affair Held in His Recently Opened Store in Port Chester, N. Y.

(Special to The Talking Machine World.)

PORT CHESTER, N. Y., April 7.—Fred H. Ponty, the well-known piano and talking machine dealer of this city, attracted much attention to his business last week through the medium of an elaborate musicale, at which a number of prominent artists from New York appeared. The lengthy program consisted of piano and violin solos, vocal selections and grand opera gems by famous stars through the medium of the Victrola and the Edison disc phonograph. The musicale was given in the afternoon and repeated in the evening, and on both occasions the recital parlor in the store was crowded by a select and appreciative gathering of local music lovers.

From the interest displayed in the music furnished by the Victor and Edison machines, the musicale will result in a number of profitable sales.



"DOLLAR" MOTORS

ARE UNQUESTIONABLY THE BEST AND CHEAPEST

LATEST SENSATION—DETACHABLE SPRING CAGE

Without any dismantling of the motor, a NEW SPRING may be inserted within a few seconds.

Many patents both at home and in every civilized country applied for.

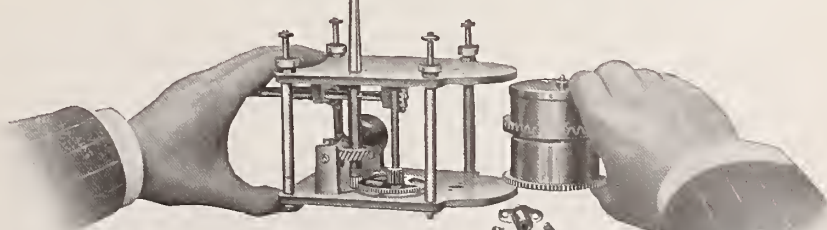

Exhibited at the Leipsic Fair, No. 20 1 Peterstrasse, Hotel de Russie, Zimmer No. 6.

Our Export Catalogue in four languages, covering 30 styles of motors adapted for Talking Machines, sent free of charge, postage prepaid, for the asking.

Advantages of our Motors: Noiseless movement Supreme accuracy Highest grade of materials Greatest money value

GEBRÜDER STEIDINGER, Fabrik für Feinmechanik St. Georgen (Schwarzwald), Deutschland

Cable Address: Gebrüder Steidinger Sanctgeorgenschwarzwald.

A NOVEL POSTAL CARD

Is That Used by Russell Hardy with the Talking Machine Co., Birmingham, Ala.

A novel postal card is being used by Russell Hardy, a clever salesman associated with the Talk-

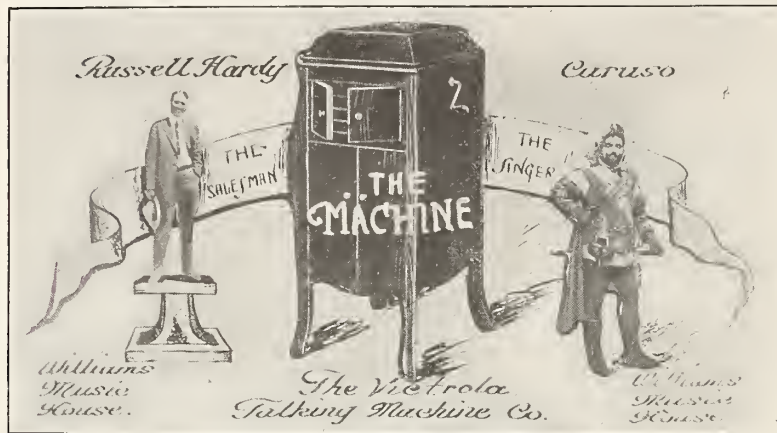

Clever Post Card Designed by Russell Hardy.

ing Machine Co., representative of the Victor and Edison lines in Birmingham, Ala. Mr. Hardy has proven his right to be considered an A1 salesman, for his average sales per month for the last three or four months have reached the \$1,000 mark.

BENJ. SWITKY IN BERMUDA.

Prominent Distributor Visiting Talking Machine Man's Haven of Rest.

Benj. Switky, the prominent Victor distributor of 9 West Twenty-third street, New York, accompanied by Mrs. Switky and their two children, sailed for Bermuda on Wednesday, April 1, for a vacation of several weeks. In view of the number of members of the local trade who have visited Bermuda during the past couple of months it would appear that the name of the resort should be changed to "The Talking Machine Man's Haven of Rest."

"LIVE" DISPLAY OF DANCE RECORDS.

(Special to The Talking Machine World.)

NEW ORLEANS, LA., April 9.—The Victrola department of Philip Werlein, Ltd, the large piano house in this city, is still being congratulated on a novel idea which it introduced a short while since in connection with the craze for dance music. The many dance records in the Victor record library suitable for all the latest dances furnished the firm with material for an unusually clever stunt which took the shape of a personal demonstration of the adaptability of Victor music to the proper performing of the latest dances.

A show window measuring 9x12 feet was decorated elaborately to give the impression of a fashionable ballroom, and in this space a well-dressed couple, masked, danced all the new dances to the music of a Victrola. Cards were displayed announcing each dance, and the grace and skill of the couple as they danced to the strains of Victor records formed a topic of general discussion that was both sales productive for the Werlein Victor department and the best kind of advertising.

GIVING MACHINES DOUBLE VALUE.

Success of the Union Devices Testifies to Their Value—Factory of the Union Specialty and Plating Co. Very Busy.

(Special to The Talking Machine World.)

CLEVELAND, O., April 6.—The prosperity and popularity of the Union Specialty and Plating Co., attachments, affording the owner of any kind of a



For Talking Machines, Typewriters, Phonographs, Adding Machines, Cash Registers, Guns and Tools and all Polished Instruments. THE FINEST OIL MADE. It absolutely prevents rust. NYOIL now sold everywhere by all hardware and sporting goods men. Large bottle (cheaper to buy) 25c.; trial size, 10c. WM. F. NYE, New Bedford, Mass.

NYOIL

For polishing varnished woodwork it is extremely satisfactory. No oil is so clean.

Ask your watch repairer whose oil he uses on your watch.

talking machine the privilege of playing any kind of a record, is evidence of their great value. Business at the factory is brisk. Mr. McNulty stated they were daily filling lots of orders and that they were receiving volumes of praise from users of Unions No. 2 and No. 3, which of course is very gratifying to the company.

H. B. McNulty, of the company, who recently made a flying trip to Iowa, and covering Chicago, states he found business very good and that the Union line of specialties was selling "like hot cakes."

The Columbia export department has been issuing some splendid publicity during the past few years which is being used by the company's dealers in South America and Europe to excellent advantage.

The Masterphone

GIVES

Perfect Detail

Rich Tone

Full Volume

Records remain perfect forever, as Victor Fibre Needles are used.

Your customers will like the Masterphone, for it adds immeasurably to the value of their instruments.

YOU EARN ADDITIONAL PROFITS.

Write for Sample and Discounts.

Steel
Needles
Masterphone
\$1.00

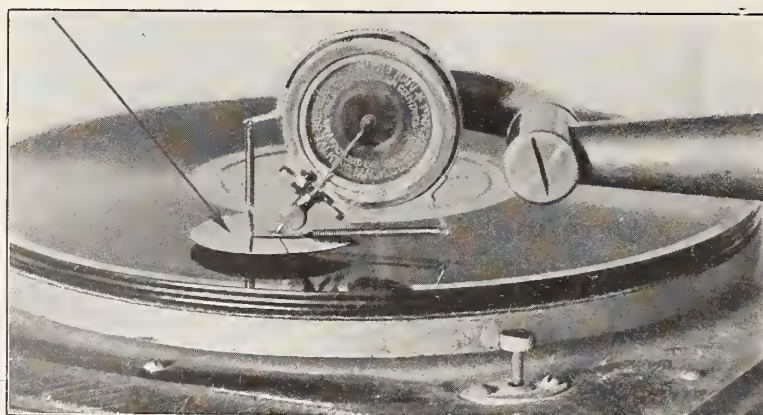

Fibre
Needles
Masterphone
\$1.50

THE MASTERPHONE CORPORATION, 187 Broadway, New York City
Telephone: Cortlandt 1872



Columbia records of song hits are real hits—hits as songs and hits as sales.



(Write for "Music Money," a book "full of meat" for those dealers interested in quick and frequent turnover of capital.)

Columbia Graphophone Company
Woolworth Building, New York

T. H. E. PUBLIC, ESQ., THE GENTLEMAN FROM MISSOURI.

Prospective Purchasers of To-day Demand Lucid and Reasonable Explanations from Merchants in Place of the Old-Style Meaningless Generalities Regarding Products to be Bought—Something of the "Department of Detail" for Talking Machine Stores.

The age of lavish explanations has arrived, Mr. Dealer, and in order that you may retain the patronage of the supercurious, you must expound your trade gospel exhaustively as well as entertainingly. You must also develop your Department of Detail to a state of high efficiency. The times demand these things from you.

To-day, in order that a talking machine salesman may take his place in the proficiency class, he must be a veritable encyclopedia of phonographic lore. He must be able to speak the 'ola language as fluently and exactly as a college professor emits Tschechisch or Croatian. Summing up concisely, he must know it all.

Every establishment where talkers are dispensed should pay particular heed to the development of its Department of Detail. Never before was attention to the smaller things of such vital importance. This situation has been brought to light largely through the medium of various worthy sundries which, when attached to the talking machine, add to its musical excellence. I have found in my tramps along the trade trail that this subject of detail is not given the care it deserves. I have visited a half dozen talker shops in Brooklyn, New York City and Philadelphia within the past few weeks where the matter of sundries was a dead issue. Does not this illustrate my point that the detail end of the talking machine business is being neglected?

Such a state of affairs is a menace to trade for this reason: When T. H. E. Public, Esq., reads in a popular magazine an attractively displayed advertisement regarding an article that promises to make his Musicola more melodious at the modest outlay of a dollar or two, he determines to investigate. He calls forthwith upon John Jones, proprietor of The Graph & Phone Co., Inc., and asks for the article he has seen advertised. He goes further than that; he demands a demonstration, and he desires it in a hurry. Then, by way of making his remarks emphatic and acquainting Mr. Jones with his identity, he shouts that he is from Missouri. To his supreme disgust, he finds that not only has Jones neglected to put the attachment he is interested in in stock, but has never heard of it. He departs amid vituperative fireworks, and his opinions regarding The Graph & Phone Co., Inc., are not publishable.

It seems to the writer that the best and easiest way to overcome this difficulty would be to peruse more carefully the pages of your trade journal. If you made it a rule, Mr. Dealer, to pass The Talking Machine World among your employes when you were through with it, and made it clear that you desired it read carefully, good results could not but accrue. The salesman who makes a practice of becoming thoroughly familiar with the contents of such a publication monthly will find himself in a position to answer any question put to him lucidly and to the point.

One dealer of my acquaintance keeps a tabulated list of sundries on hand for the use of his salesmen. His stenographer has charge of this work, and as The World arrives she looks it over and adds to her list whatever invention of moment has come to life during the month. She simply writes down the name of the article, together with the volume and month of the magazine in which it was advertised or described. Carbon copies of this typewritten list are posted in conspicuous place throughout the store.

A few items from one of the pages of this sundry list follows:

LIST OF TALKING MACHINE SUNDRIES FOR USE OF SALES FORCE.

Automatic stops:	
Columbia	T. M. W., Vol. X, No. 3, page 7
Standard	" " " " " 31
Bagshaw Needles	" " " " " 19
Delivery bags	" " " " " 22
Dollar motors	" " " " " 15
Fibre Needle Cutters:	
L. & H.	" " " " " 32
W. & W.	" " " " " 33
Heise System	" " " " " 14
Masterphone	" " " " " 16
Nyoil	" " " " " 16
Union T. M. Specialties	" " " " " 27
Unique Record Albums	" " " " " 6

As the trade journal subscribed to by this dealer is carefully filed, it is easy for the salesman to ar-

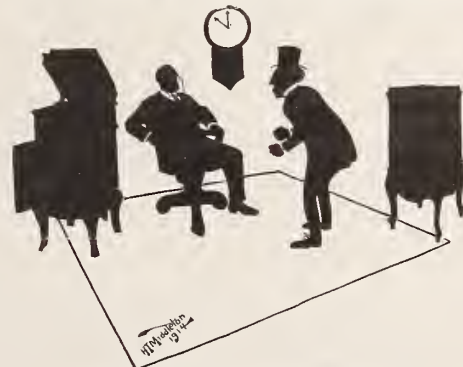

He Demands a Demonstration.

rive at the desired information at a moment's notice. By adopting this method, Mr. Dealer, it is practically impossible for a patron to go away from your store without having learned all about talking machines and their accessories.

Another page in the salesman's book of knowledge that is seldom read is the one which deals with the care of the "talker." Most chaps are so saturated with the mania for making sales that they do not give a thought to anything beyond the disposal of the outfit. The dealer of sundry list renown has a repair catalog for the various makes of machines. This, too, is displayed at different points in the store where the eyes of the salesman can reach it, and by consulting it he is very often enabled to prescribe successfully. Of course, where the condition of the patient is such that an operation is necessary, the services of the surgeon from the Department of Restoration are

required. Where a dose of oil, graphite, etc., administered in just the correct proportions, is sufficient to renew activity, the repair catalog is invaluable.

A salesman can sell goods much more intelligently if he has seen them in the making. This being true, would it not be advantageous to manufacturer and merchant alike if some arrangement was arrived at whereby salesmen were given access to the factories and laboratories of the builders of talking machines and the entire process of production witnessed and described? Henry Ford, of profit-sharing fame, has adopted this method of educating not only the folks who are interested in his car as a business proposition, but T. H. E. Public, Esq., as well. He even goes so far as to include a moving picture show in the course of instruction.

What will work out successfully in the world of automobiles should apply to the talker fraternity also, and it would aid him very materially, I am sure, if every young man who derives a livelihood from the sale of talking machines could pay a visit to the producing plant in order that he might become enlightened as to the practical side of their creation.

Do not take my word for it that the matter of a comprehensive knowledge of talking machine manufacture is non-existent in the mind of the average salesman. Take your star sales expert aside and ask him about it. Methinks I hear the echo of his answer: "I'm sellin' goods, not makin' 'em. 'Isch ga bibble!"

HOWARD TAYLOR MIDDLETON.

ANNUAL DINNER OF DEALERS.

Eastern Talking Machine Dealers' Association Making Elaborate Plans for Annual Gathering on May 6—Meeting to Be Held a Week Later to Elect Officers and Hear Reports.

The annual dinner of the Eastern Talking Machine Dealers' Association will be held on May 6, according to plans announced following a meeting of the Executive Committee of the association held at Keen's Chop House on April 6. The place for the dinner has not yet been selected.

John G. Bremner, president of the association, announces that the program for the dinner will be particularly interesting, and a number of speakers of note, including at least one man of national importance and prominence, will be present.

The annual meeting of the association, for the election of officers and for the transaction of other regular business, will be held on the week following the dinner in order to avoid the confusion that would arise by having the dinner and meeting on the same evening.

If Terpsichore were to return to earth and watch a tango tea some evening, she'd probably apply to the Olympian courts to have her name changed the next morning.

It's a modest man who doesn't think the photographer could have made a better looking picture of him if he'd only tried.

THE TRADE IN BOSTON AND NEW ENGLAND

JOHN H. WILSON, MANAGER, 324 WASHINGTON STREET, BOSTON, MASS.

(Special to The Talking Machine World.)

BOSTON, MASS., April 10.—Beginning on April 2 and continuing through to-day there has been a Business Efficiency Exposition at Mechanics' building, and among the notable exhibits were the dictaphone, shown by the Columbia Graphophone Co., and the Edison business phonograph, exhibited by Mershon & Klinefelter, of 18 Tremont street. Both of these exhibits were in the main aisle of the hall, their locations being about the best among the 100 exhibitors of time and labor saving devices. The Columbia exhibit was in the midst of handsome mahogany furnishings, these including tables, chairs and desks, and the machines sent over to illustrate the facility of dictating were the best that the home office could exhibit. Palms and plants helped to make the display attractive. Andrew Atwell, the manager of the dictaphone department of the Columbia, was in charge of the exhibit. Similarly the Edison dictagraph was in artistic surroundings and it received its share of well-merited attention.

Reports Good Month's Business.

Manager Batchelder, of the Victor department of the Henry F. Miller Co., reports a very good month's business. The April list of records has proved especially popular, and the office staff has been busy attending to the wants of many customers.

Will Continue Columbia Department.

Mr. Navin, of Navin & Kelley, of 757 Washington street, has bought out the Columbia department in the Henry Siegel Co.'s store, which recently went into insolvency. The new firm of W. & A. Bacon, an old-established Roxbury house, which bought out the Siegel store, has been agreeable to the proposition that the Columbia department be continued there, and Mr. Navin has some progressive ideas as to how the department should be conducted. William L. Dunn, of the Columbia offices, has been chosen to be the manager and he starts in with high endorsements.

George W. Lyle a Visitor.

George W. Lyle, general manager of the Columbia Graphophone Co., was a hurried visitor to the Boston warerooms a fortnight ago, and he found Manager Erisman right on the job. Another Boston visitor was H. A. Yerkes, the Columbia's wholesale manager, whose trip to Boston was of a meteoric character.

To Visit the Victor Factory.

Business at the Eastern Talking Machine Co.'s establishment continues good, and already there

is considerable of a call for equipments suitable for country homes and shore cottages. Billy Fitzgerald, Mark Reed and Mr. Splaine are looking forward expectantly to their trip over to Camden and Philadelphia on the 18th of this month, where they are going to inspect the Victor laboratories and study the manufacture of machines and records. The trip will give them a renewed fund of knowledge as to Victor workmanship. They will be away three days.

Renewed Acquaintanceship.

H. A. Beach, of the Victor Co., came over to Boston for a few days and renewed acquaintance with the boys of the various Victor distributors, those of the Eastern Co. in particular. Mr. Beach is the general representative of the factory.

More Room for Ditson Department.

Henry A. Winkelman, manager of the Victor department of the Oliver Ditson Co., has been forced to make several changes in his second floor suite because of the rush of business. Most of the records are now kept at the rear of the floor in rooms especially prepared for them, and by this rearrangement space is allowed for an additional demonstration booth toward the front half of the suite. Mr. Winkelman's bland smile tells the story of good business. His many friends enjoyed meeting him at the dinner of the Boston Music Trade Association at the Hotel Lenox a few weeks ago.

Columbia Dance Records in Demand.

Manager Arthur Erisman, of the Columbia Co., reports that it is an even toss up between school propositions and dance music, for the latter, since the tango and other modern forms of dancing came in, has made heavy demands on the Columbia equipments. Although Manager Erisman laid in a large stock of this kind of dance music he is constantly obliged to send over to headquarters for fresh invoices of records.

Talks with Sales Staff.

A busy man is Manager Royer of the Victor department of the M. Steinert Co.'s Arch street quarters, these days, especially as he had been away for several days paying a visit to the Victor laboratories. During his absence business piled up so he has had to bend all his energies to get it dispatched with some degree of promptness. Mr. Royer lately has held two sales talks with his staff, discussing business methods and getting an exchange of views from the men as to new ideas that will aid in promoting business. At the conclusion of these conferences the boys all repaired to a near-by hotel for supper.

Changes in Columbia Co. Quarters.

When the changes are completed in the two floors of the Columbia Co. made necessary by the cutting off of a few feet of the store for the Avery street widening, which was referred to in last month's issue of The World, the establishment will be almost new. Just now Manager Erisman and his large staff are working under adverse conditions, Mr. Erisman's private office in particular being quite inadequate for present needs. On the second floor two new demonstration booths will be installed, which will greatly facilitate business.

Rosen Artistic Quarters.

Henry Rosen, of School street, has taken a lease of a large apartment at 246 Huntington avenue, opposite Symphony Hall, as mentioned briefly last month. He is equipping the room in a highly artistic manner, and will place this branch under the management of a competent man, but at this writing the right man has not been selected.

Take on the Edison Line.

The Shawmut Furniture Co., of 269 Tremont street, has lately taken on the Edison line and its rooms devoted to these goods are visited by all the patrons of the store whose attention is directed to the value of Edison equipments.

W. E. Getchell Ill.

W. E. Getchell, who has charge of the New Hampshire and Vermont business of the Columbia Co., has the sympathy of his hosts of friends because of his long continued illness. Mr. Getchell was taken sick in Brattleboro, and on the advice of friends went over to New York to consult a specialist and hospital treatment followed.

Increase Sales Staff.

Manager Erisman has made several additions to his already large staff. A. G. Haskell and S. B. Bowman have been taken on at the retail department, and E. W. Graham has come East from the Chicago office to travel for Manager Erisman's branch of the Columbia. All three are excellent men.

Signs Up Many New Accounts.

W. O. Pardee, of the Pardee-Ellenberger Co., was in town a few days ago and he told your correspondent that he had signed up a number of good accounts at New Haven, Norwich, New London, Bridgeport, Stamford and New Britain. He says that everywhere he goes he hears the most enthusiastic things said of the Edison disc machines.

Columbia Brieflets.

Miss Mabel Jones, who has been doing splendid work for the Columbia in demonstrating the Co-

**Real Music
At Last**

RIGHT from the announcement of the new Edison Diamond Disc Phonograph came orders; orders are coming in more plentifully and all the time, which shows the immense possibilities for profits in your section. This machine practically sells itself, and at a price that is in every way satisfactory, running from \$60 to \$450. Records

help swell profits after you sell the machine.

As a business the foregoing should appeal to you, and we'll be glad to add the complete story if you'll ask for it.

The Pardee-Ellenberger Co.

Boston, Mass.

New Haven, Conn.

THE TRADE IN BOSTON AND NEW ENGLAND

JOHN H. WILSON, MANAGER, 324 WASHINGTON STREET, BOSTON, MASS.

lumbia grand, was taken ill at Nashua, N. H., lately, and her condition was such that she has been ordered by her physician to take a long rest. Accordingly she has gone to her home in Maine, where she will spend the summer.

John L. Gately, the New England representative of the Victor, has been quite ill at his home in Somerville, but last reports were that he was well on the road to recovery.

These fine spring days are when Manager Erisman, of the Columbia, tries to get a few hours in the afternoon for a game of golf, and he often finds himself matched up with some of the most prominent players of the day. Erisman is pretty good with the sticks, too.



CANNED 'POSSUM A LA EDISON.

Brer 'Possum's name is famous;
He's known throughout our land.
Milady pays good money for
His hide when it is tanned.

II.

The muff that nestles softly
Against her dimpled cheek,
Was once this midnight prowler's coat
So smooth, and gray, and sleek.

III.

"He's good to eat," says Rastus,
"When roasted, stewed, or panned."
Behold him in his latest role:
His voice is being canned.

HOWARD TAYLOR MIDDLETON.

HEAVY DEMAND FOR NEEDLES.

Products of W. H. Bagshaw Popular in All Parts of the World—An Up-to-Date and Well Equipped Plant.

(Special to The Talking Machine World.)

LOWELL, MASS., April 9.—In a chat with C. H. Bagshaw, general manager of W. H. Bagshaw, of this city, he spoke enthusiastically about the condition of business and the demand for Bagshaw made talking machine needles. No doubt this house will do the largest business that has ever been transacted in its career—not only shipping their production to this country, but to South America, Australia, Japan, Argentine, England and other foreign countries. The plan of this organization in creating a high grade line of products and catering only to the class demanding this character of goods shows the success of a sane merchandising plan.

Recently was installed a machine at the Bagshaw plant capable of automatically counting needles operated by the force of one needle, which shows how delicately it must be adjusted in order to fulfil requirements of the machine.

The house of Bagshaw is continuously adding new and efficient machinery in order to always better the character of its production.

ENLARGE EDISON DEPARTMENT.

E. P. Hart & Co., of Great Barrington, Mass., Preparing for a Large Summer Business.

(Special to The Talking Machine World.)

GREAT BARRINGTON, MASS., April 7.—E. P. Hunt Co. of this town has lately enlarged its department store so as to make adequate room for a well-equipped Edison department and this enterprising house now takes its place among the leading Edison dealers of Western Massachusetts. The company is preparing to do a large summer business among the many who annually go into the Western part of the State for their vacations.

VISIT MARKETS MORE FREQUENTLY.

Wholesale Buyers Visit Big Centers Several Times a Year Instead of Once or Twice, as Formerly—Taken to Indicate the Passing of Seasons in the Placing of Orders.

Twenty years ago, according to experienced local wholesalers, it was only on the rarest occasions that a retail merchant came to this market more than twice a year. At that time, they say there was by no means the number of individual buyers there are to-day, which usually meant that the merchant himself did all, or nearly all, of the buying. In those days the individual purchases were much larger than they are now, despite the increased population of the country and the greater number of retail outlets. Then a whole season's merchandise was often contracted for at one time, and if the merchant were not a good buyer he paid for his ignorance or ill luck.

With the separation of stores into departments and the resultant increase in the number of buyers per store, the individual purchases became smaller and more frequent. Buyers used to come to market twice a year, or they came three or four times if they were not too far from Boston. Now they come more frequently, and it is not a rare thing for many out-of-town buyers to visit this market every month. Never before have the hotel registers borne the names of so many buyers at this time of the year. In some quarters this is taken as a definite sign that the retail distinction between the seasons is passing, but in other quarters the delayed visits of buyers.

FULTON MUSIC CO. IN NEW QUARTERS

(Special to The Talking Machine World.)

WATERBURY, CONN., April 7.—The Fulton Music Co. has just moved into larger quarters in the central part of this city and on one of its floors it has installed a large talking machine department where it is featuring the Edison line. The rooms are attractively furnished and many persons have paid the place a visit which has resulted in many sales and numerous good prospects.

"TOO BUSY TO READ."

He is a familiar type—the fussy, fretful man who imagines that he is about the busiest fellow in town. He often dumps in the waste basket, unwrapped copies of business or technical magazines that contain valuable articles bearing directly on his problems. He fondly believes that he is too busy practicing to bother with what others are "preaching."

The trouble with this type of man is that he has not learned that the real executive is the man who so plans his work as to leave a reasonable amount of time for reading and planning, says *Printers' Ink*. There are shoals and breakers ahead when the accumulation of new ideas ceases. The man who declares he has no time to read is unconsciously advertising his small caliber, his slavery to detail, his arrested development.

ADD MORE SOUND-PROOF ROOMS.

(Special to The Talking Machine World.)

NEW HAVEN, CONN., April 7.—The A. B. Clinton Co. of this city has just completed some radical changes in the interior of its establishment, and several sound-proof booths are proving highly advantageous to customers. In the last few weeks the company's business has developed to large proportions.

HOW COULD HE?

The Girl—Do you enjoy music with meals?
The Man—Rather!
The Girl—What do you prefer, a waltz?
The Man—No, a chew-step!—London Opinion.

It requires tremendous energy to handle millions economically

WHILE brains count to the fullest degree, still in making talking machine needles it is necessary to have the most modern equipment, for the tiny needles have to be handled in lots of millions. This branch of our business is receiving constant attention by our engineers who are continuously improving our machinery and enabling us to MAKE THE BEST NEEDLES.

Established 1870

Pioneer
Needle Makers

W. H. BAGSHAW
Lowell, Mass.

A NEW SALTER STYLE

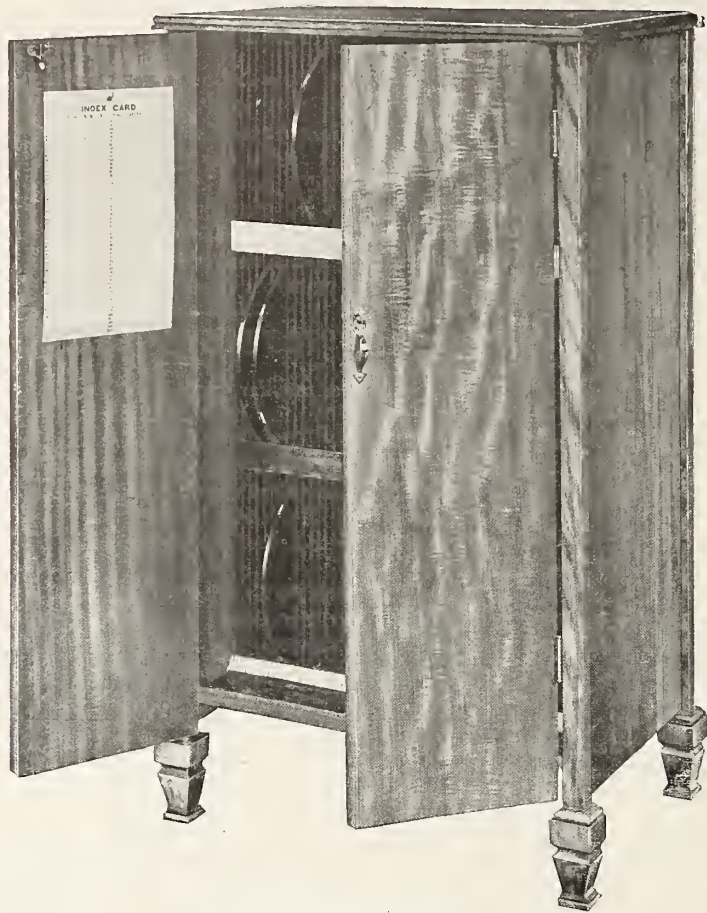

SALTER STYLE No. 20.
Separate sections for 10-inch and 12-inch records.

THAT EVERY DEALER
SHOULD KNOW ABOUT—

is this elegant and novel cabinet that our designer has just completed and which we now offer to the trade.

This new Salter feature has been designed to match the EDISON Disc Phonograph, and holds 132 Edison records in separate felt-lined compartments. It is also constructed with 159 such compartments to receive VICTOR or COLUMBIA records.

Many owners of the latter named machines are using this cabinet as a "record stock" or "overflow" cabinet, and it fills the bill most satisfactorily.

The Style No. 20 is 44 ins. high and $17\frac{1}{4} \times 24\frac{1}{2}$ ins. across the top. It has a simple and accurate indexing device. It is finished in beautiful mahogany and oak veneers in a number of different shades.

Ask for complete catalog.

Salter Mfg. Co.

337-43 N. Oakley Blvd. CHICAGO

MARCH A RECORD MONTH FOR CLEVELAND TRADE.

Excellent Increase in Business Reported by the Majority of the Talking Machine Houses
—Columbia Co., Disposes of Retail Business and Opens Exclusive Wholesale Quarters
—H. M. Brainard Piano Co., Moves—All Lines of Machines and Records in Demand.

(Special to The Talking Machine World.)

CLEVELAND, O., April 6.—March was a month of uncertainty and hesitation in business generally, yet in that month Cleveland made a fine record in several important phases, particularly in the substantial status of the talking machine trade, the increase in bank clearings and in the number of building permits issued, all showing remarkable evidence of exceptional vitality. The supply of machines is apparently ample, although there is a scarcity of two or three types, while the complaint of a shortage of Victor records is general. The fact is the growth of the business has created a demand for records far in excess of the supply, and which is likely to continue.

The recent notable event in talking machine circles was the disposal by the Columbia Phonograph Co., of its retail business, and the establishing of an exclusive wholesale quarters for Columbia graphophones and records and the dictaphone, at 1375 Euclid avenue. The new store is located on the fourth floor of the Kinney & Levan building, which has a Euclid frontage of 100 feet, and extends 450 feet to the rear. The store has been fitted up in fine style for the business purposes of the company. Mr. Madson, manager, says the business is growing by leaps and bounds.

Another event was the removal of the H. M. Brainard Piano Co. from 6525 Euclid avenue, to 1317-19 Euclid avenue. The company has fitted up a magnificent store for the piano and talking machine business. Six large talking machine demonstration parlors have been installed, together with manager and cashier's offices. The company handles the Columbia goods exclusively, and the manager says he expects to do as large a talking machine as piano business.

In a talk with T. H. Towell, president of the Eclipse Musical Co., he said everything was very satisfactory, except that they were handicapped by a shortage of both machines and records, especially the latter. P. J. Towell, brother of the president, and who looks after the interests of the Eclipse Musical Co., generally, said business was good and would be 50 per cent. better, if he could get the goods. His birthday (he is still a boy) occurred a few days ago, and a luncheon was tendered him by the employes of the store. He was presented with a beautiful diamond pin by his brother.

"Notwithstanding the fact that our record stock has been in awful conditions since January 1," said Wm. G. Bowie, manager of the Victrola department of the B. Dreher's Sons Co., "our business this year to date is almost double that of 1913."

"Business is very good," said Norman H. Cook, of the W. F. Frederick Piano Co.—"in fact, is of such volume as to exceed our expectations."

The magnificent window display continues to attract the attention of crowds daily at the Caldwell Piano Co.'s store. R. W. Schirring, manager of the Victrola department, said trade in the talking machine line, along with the piano business, was very satisfactory, but would be much more so if a sufficient supply of machines and records were obtainable.

The Victor department of the Wm. Taylor Son & Co., is one of the attractive sections of the store. T. A. Davis, Jr., reports trade as brisk and constantly increasing.

O. E. Kellogg, manager of the piano and Victrola department of the H. E. McMillan & Son Co., reports a very fine business for the month of March. He said several \$200 machines were sold during the month, also a number of \$100 ones.

Evidence of increasing business is quite manifest at the store of the Phonograph Co. There has been an addition to the clerical force and activity prevails in all departments. L. N. Bloom, secretary, stated that trade, both wholesale and retail, during the past month, had been unusually good. "There were," he said, "a number of the high-grade Edison disc machines sold in the best homes in Cleveland during the month, and a number of new dealers were assigned to handle the Edison goods, among others, the Moorehouse-Martens Co., Columbus, O.; H. Ackerman, Galion, O.; the National Phonograph Co., Steubenville, O., and Cooley & Bentz, Wheeling, W. Va."

Trade is reported excellent and conditions generally very satisfactory at W. H. Buescher & Sons Co., as well as at the Bailey Co., the May Co., Collister & Sayle Co., and the Euclid Music Co.

EFFECTIVE DITSON ADVERTISING.

One of the most attractive Victor advertisements that has appeared recently in the daily newspapers was that used this week by Charles H. Ditson & Co., 8 East Thirty-fourth street, New York, the well-known musical instrument house, whose Victrola department has been steadily enlarged to handle a fast-growing trade.

This advertisement took cognizance of the widespread demand for dance records, and, in addition to an appropriate cut, mentioned the various dances, such as the maxixe, hesitation, tango and Boston, by name under the heading, "A Victrola for Every Home." The different models of Victrolas were featured with their respective style numbers and prices and attention was called to some of the most important records in the new April list. As a whole the text in this advertisement was interesting and convincing and well calculated to produce excellent results, in addition to forming strong publicity.

Sometimes it seems as if a man ran for office merely to find out from his enemies how utterly outrageous his past life has been.



We still talk the Columbia "Leader" Grafonola, because it is the biggest thing in the industry to talk about.



(Write for "Music Money," a book "full of meat" for those dealers interested in quick and frequent turnover of capital.)

Columbia Graphophone Company
Woolworth Building, New York

THE REAL REASON FOR THE SHORTAGE IN RECORDS.

Present Conditions Reflect Tremendous Volume of Business That Has Been Handled and Should Be Cause for Rejoicing Rather Than for Condemnation, Says Benj. Switky, the Prominent Victor Distributer of New York—Situation Carefully Analyzed.

For the past two or three months Victor dealers have suffered from a shortage of records never before witnessed in the history of the trade. This condition, which on the face of it would seem to be unfortunate, is the direct result of the tremendous record sales enjoyed by all prior to and during the holiday season. Therefore it is self-evident that there should be rejoicing instead of condemnation over the present state of affairs. A little mature reflection would prove to us that the present is no time for pessimism.

Let us analyze the causes leading up to the shortage, and then try to realize what it all means. I am sure that from the analysis we will be able to draw much comfort and inspiration, and that the gloom and discontent that have enveloped the minds of some will be dispelled, giving clearer vision and more cheerful disposition; likewise, we owe it to the manufacturers to express appreciation of their valiant efforts to relieve the situation.

On November 1, 1913, all jobbers' stocks were ready for the anticipated holiday demands. The record bins at the factory were loaded with hundreds of thousands of records that had been pressed during the summer and fall. By December 15 it seemed that nothing had been overlooked in the way of preparedness to supply the demand, no matter how great it might be.

But, lo and behold, the country's record sales of the next two weeks were like the breaking loose of a fierce Western cyclone sweeping everything before it! The standard sellers were in tremendous demand; the dance craze, which had been gathering momentum during the several months preceding Christmas broke in upon us like a volcanic eruption. We were prepared for an abnormal demand, but no one could foresee a condition such as confronted us on December 24.

The factory poured forth its reserve record stock in tremendous shipments, but they were powerless to stem the rush of the flood. The record business of December, 1913, was unique. It surpassed all other years.

A Comparison with Other Industries.

Let us pause to see what we can see. What was the condition of the country in general at about this time? How were other industries faring? What was the tone of the money mart? Were stocks going up or were values decreasing? What was the condition of the labor market as a whole? The answers are all negative. In some quarters there was despair, in others gloom, and in still others uncertainty that boded no good. Capital stood idle, trembling, undecided. There were advancing clouds and distant rumblings that foretold the approach of a storm. Men were speculating as to whether the clouds would pass or whether the storm would break over their heads. All sorts of causes were blamed for the general business depression: the November elections, the tariff tinkering, the currency bills, proposed anti-trust legisla-

tion, international complications, the unseasonableness of the weather, etc., etc., etc.

Wherein lies our lesson? It is this: The popularity of talking machines and records is so great that even unfavorable times cannot dim the brilliance of our prosperity. There seem to be no barriers tall enough or strong enough to retard the onward march of our progress. When we think of the records sold in December, 1913, in spite of hard times, what may we not expect for our harvest when the country shall bathe in the sunshine of general prosperity?

There is no room for pessimism. To complain because of the present shortage is equivalent to finding fault with last December's business on the ground that it was too big.

The Problems of the Factory.

But some men may ask, what is the factory doing to refill the empty record bins? Very little, we must admit. This is not because the presses are idle—on the contrary, they are working to full capacity—but because the orders for the new monthly records are so great that there is very little chance left to press catalog stock. The jobbers, having discovered that they cannot count with certainty on receiving duplicate shipments on reorders of popular sellers, have adopted the plan of plunging when placing initial orders for monthly records. Instead of ordering conservatively, and then reordering every three or four weeks, they now try to corner a three or four months' supply. This, of course, works additional hardship on the factory and delays the refilling of the bins devoted to the older selections.

It has been suggested that relief would be had by eliminating one of the monthly lists; but the factory does not deem it wise to withhold from the buying public for a period of sixty days certain hits that are in great demand and which should be issued as quickly as possible. Besides, it is better to give the trade records that are in immediate demand than to press a lot of staple records merely for the sake of replacing old numbers.

If I had my way I would grasp the present as an opportune time for performing a radical operation upon the Victor record catalog. There are many selections in the catalog that sell so slowly that it is a waste of jobbers' and dealers' capital to carry them in stock. The needless repetition of the same selection by many different artists serves no other purpose than to squander capital and make retail selling more burdensome.

There seems to be a feeling among the trade that the present record shortage has another and deeper significance; that the failure on the part of the factory to replenish stocks during the past three months is part of a plan to prepare for the introduction of new product—possibly a new record composition, or something of that sort. Although the factory has given assurance that such a move is not now contemplated, it will do no harm

to discuss the attitude of the factory toward such a contingency.

That there would some day be certain radical changes and improvements in Victor products was announced at the jobbers' convention at Atlantic City not quite two years ago. Louis F. Geissler, general manager of the Victor Co., in the course of his address made it plain to his audience that the Victor Co. was prepared to defend and retain its title of champion against all newcomers and oldcomers. I cannot quote him verbatim, but the essence of his talk was this: That the Victor Co. did not believe in making changes or issuing new product faster than the public could digest them; but that there were several hundred patents filed away for future reference of which it had not yet availed itself; and that when the proper time came the Victor Co. would issue product that might necessitate making a bonfire of then existing machines and records.

And when that time comes the trade can depend on it that everything possible will be done to prevent a radical depreciation in the value of the salability of its stocks. The Victor Co. has in the past year given many evidences of its ability to cope with situations requiring heroic treatment. The welfare of its dealers has always been uppermost when changes were found necessary.

The Victor Co. can be depended upon. It has never offered a sink-or-swim proposition to its trade when important changes were imminent.

Therefore, with an illustrious selling career behind us, with present good conditions prevailing, and with such bright prospects confronting, can any man say that he is justified in being aught but an optimist? A little patience at the right time accomplishes a heap of good.

NEW MUSICAL INSTRUMENT

Announced by J. Hoffay, of London, Exciting Much Interest in the Trade.

Jose Hoffay, who is well known in the talking machine trade in the United States and South America, and who is now residing in London, makes an important announcement on page 47 of this issue of The World regarding a new musical instrument which will play every kind of disc record and in a most perfect manner.

The English trade seem very much interested in this new instrument which was referred to in the London correspondence of The World last month, and great things are expected of it.

NAME PLATES
DECALCOMANIE

Why not apply a transfer nameplate on your talking machine cabinets?

WRITE FOR SAMPLES AND PRICES. SKETCHES FREE

GEO. A. SMITH & CO. INC.
74 CORTLANDT ST., N. Y.

Strongest Envelope in the Country

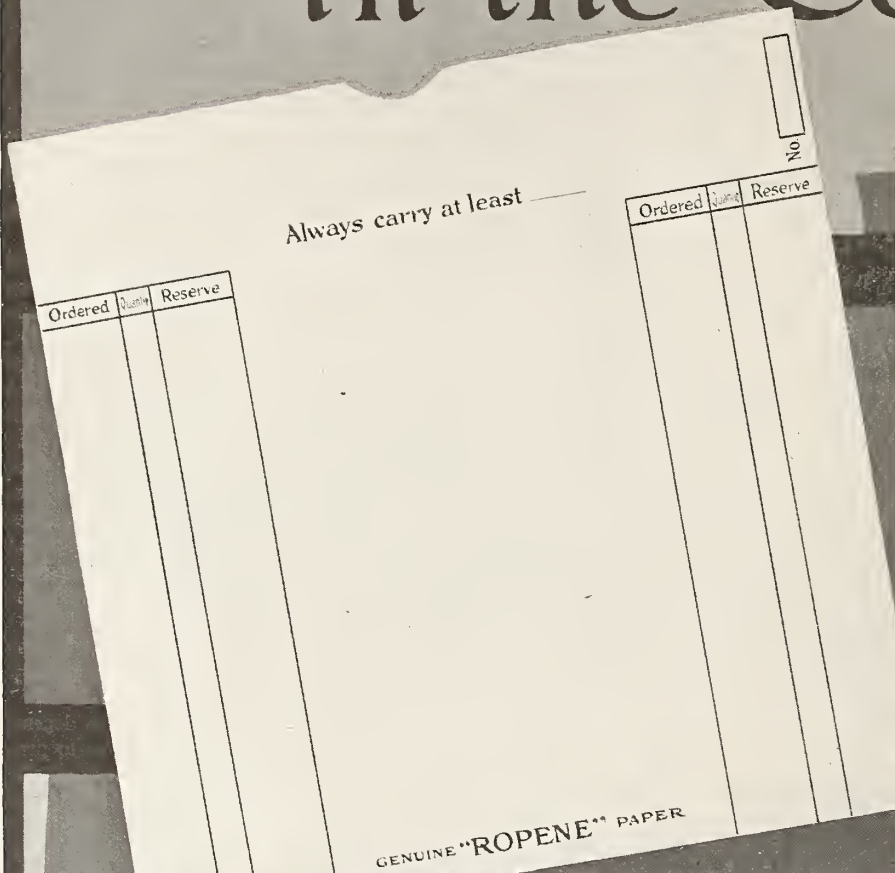

CABLE ADDRESS: FAIRBANKS
CODES: A. S. C. A. T. T. C. T. O. N.
LONDON AND WESTERN UNION

TELEPHONE SPRING FIELDS

FACTORY NO. 1, BUSHAMOND, N. Y.
FACTORY NO. 2, JOURNALVILLE, N. Y.
FACTORY NO. 3, JOURNALVILLE, N. Y.

THE FAIRBANKS COMPANY
BROOME & LAFAYETTE STREETS,
NEW YORK March 30, 1914.

C E R T I F I C A T E

This is to certify that I, Charles W. Ludlow, in the presence of George A. Kelly and others, tested a "Popene" Stock Envelope, which was submitted to us by the New York Talking Machine Company, the test being made by clamping the bottom and top of the envelope with iron clamps and suspending a 1600 lb. Test Weight from the bottom. When placing two additional 50 lb. Weights on top of the 1600 lb. Weight the envelope broke.

Charles W. Ludlow

Sworn to before me this
30th day of March, 1914

[Signature]
Notary Public

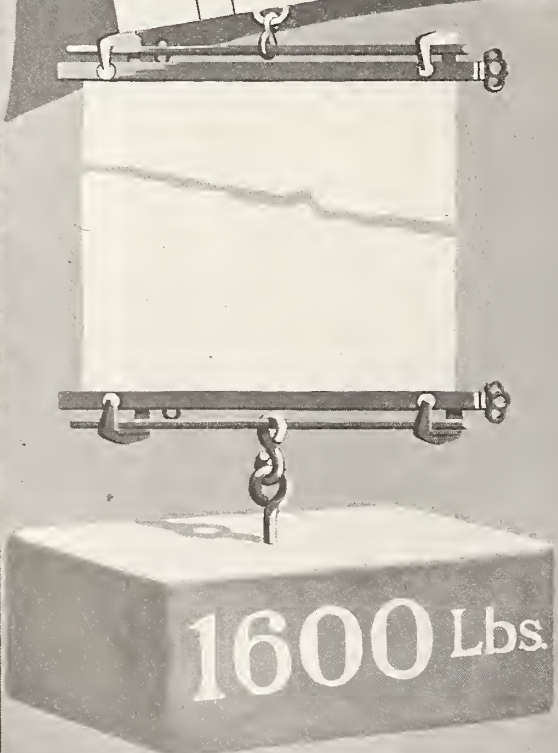

As stated in the affidavit—
This envelope actually raised 1600 lbs.
from the floor before breaking.

It's three times as strong as any envelope
on the market—and will wear three times as long.

It won't show finger prints that are noticeable on
other manila and highly colored envelopes.

Our data covering the use of this envelope, makes
the ordering of records automatic.

Envelopes

	LIST PRICE
10 in. size per thousand - - -	\$12.00
12 in. size per thousand - - -	15.00

Discounts to Distributors and Dealers

NEW YORK TALKING MACHINE COMPANY
81 Chambers Street - - - - - New York

NEW YORK CITY TRADE CLOSES GOOD MARCH BUSINESS

Despite Continued Shortage of Records and Some Types of Machines—Dance Craze Still an Important Trade Factor—With the Advent of the Summer Season a New Demand Will Materialize—What Leading Dealers Report to The World—News of the Month.

Despite the continued shortage of all types of machines and records, talking machine dealers in New York City with practically no exception reported the closing of the best March they ever experienced, but nevertheless could not refrain from commenting on the sales totals they might have reached if more machines and records had been available. Here and there is a dealer who remarks point blank that neither the manufacturers nor the distributors are to blame for the tremendous shortage in all lines, but rather the public, who recognizing the value of the talking machine as a medium for the ideal interpretation of the modern dances, has swamped the dealers with orders for machines and records.

In connection with the modern dance craze, those pessimists who a few months since voiced the opinion that this craze would not last after the first of March are finding themselves greatly mistaken, as judging from all present indications, the dance craze has not yet reached its summit by and means, but is gaining and gaining month after month. With the advent of the summer season outdoor life will undoubtedly mean a continued heavy demand for appropriate dance music with corresponding machine orders, and the local talking machine dealer is indeed a confirmed pessimist who feels that the coming summer will not be a profitable one from a business standpoint.

The Question of Publicity.

One noticeable feature of the past month's business was the absence from the daily newspapers of a goodly percentage of the talking machine advertising that is usually found in local advertising columns. This was particularly true in the middle and last week of March, when the dealers realized that they could not supply the demand for dance music, and felt that it was too early to spend money advertising appropriate Easter music. With the approach of the Easter season, however, newspaper advertising showed a marked increase from the talking machine dealers, and this advertising produced splendid results. The live-wire local dealer realized some time since that with the scarcity of dance records it would be advisable and profitable to educate the public to the real beauties of the many kinds of music in the record catalogs, and this publicity has resulted in marked increases in the demand for opera, light opera and musical comedy selections.

Opening of Landay Bros.' New Store.

One of the events of the local trade the past month was the opening of the new store of Landay Bros., the prominent Victor distributors at 427 Fifth avenue. This store is undoubtedly one of the finest Victrola establishments in the country, and is indeed a credit to the remarkable strides being made by the Victor products. The furnishings and decorations are beautiful and decidedly unique, and, as one newspaper account remarked, really baffle adequate description. Landay Bros., upon the opening of this new store, which is their fourth in the best shopping centers of New York, were accorded the unique honor by the local newspapers of having their store described in detail in the Sunday newspapers following the formal opening day. Such newspaper recognition has been accorded very few local establishments, and indicates the standing of the Victrola and Landay Bros.

New Columbia Store Doing Well.

The Columbia department in the new F. G. Smith store at 335 Fifth avenue is already closing an excellent business, although it has been open but a few weeks. Hayward Cleveland, the popular Columbia veteran, is in charge of this department, the Columbia store on Twenty-third street having closed coincident with the opening of the new department on Fifth avenue. This latest Columbia department marks the entrance of the company on the best sales district of Fifth avenue, and when all improvements and changes are completed these Columbia warerooms promise to form one of the most attractive talking machine departments in the local trade. Additional booths are being constructed to adequately handle the department's high-class trade.

Excellent Condition of Business.

"Business is really splendid," said H. N. Purdy, of the Edison disc department of Hardman, Peck & Co., 433 Fifth avenue. "During the past few weeks our machine sales have been steadily increasing, and the new Edison dance records are achieving a splendid success. Our \$150 and \$200 types of machines are still proving the best sellers in our line, but we expected this in view of the high-grade clientele that our institution caters to. Practically our entire business is conducted on a cash basis, only a very small percentage of our sales calling for deferred payments."

Co-operating with the Dealer.

"In these times of record shortage we are co-operating with our dealers in every possible way," remarked V. W. Moody, sales manager of the New York Talking Machine Co., 81 Chambers street, New York, Victor distributor. "We explain to them in detail how they can increase the efficiency of their record department, and co-operate with them in the proper selection of their record stocks. This co-operation is proving of real value to our numerous clients."

Opened Many New Accounts.

"Probably the most important feature of our business the past month has been the large number of new accounts that we have opened," said R. F. Bolton, manager of the Columbia Co.'s wholesale store, 89 Chambers street, New York. "Aside from the many new Columbia agencies entered on our books the past few weeks, the marked shortage of dance records is one of the trade's features. The prestige and standing of many of our new accounts is indicative of the rapid strides that Columbia products are making in the minds of the city's leading retail establishments. Our gain over last March was 60 per cent., which we are naturally very proud of, considering general business conditions."

New Edison Disc Records Admired.

"The new Edison disc records are being praised by each and every one of our customers," said Dana F. Parkhurst, manager of the Edison department of the Tower Manufacturing and Novelty Co., 326 Broadway. "These new disc records are proving welcome additions to our patrons' record libraries, as they are typical of the true musical qualities of the Edison disc product. The most popular seller in our line is the \$200 machine, which bids fair to take its place as one of the standard sellers of the phonograph industry."

Reports Good March Business.

Charles Bobzin, manager of the Silas Pearsall Co., 16 West Forty-sixth street, New York, Victor distributor, reports the closing of an excellent March business, particularly in the wholesale department, where the company gained many new accounts in the past few weeks.

What Others Report.

The talking machine department of the Pease Piano Co., 128 West Forty-second street, handling Victor and Columbia products, is being enlarged to handle the company's fast-growing trade. Additional soundproof booths are now being constructed for this department.

At the Victrola section of the John Wanamaker store two well-known dancers have been appearing in interpretations of the modern dances, the music for which is furnished by a Victrola. These dances have attracted city-wide attention.

Among the local dealers and talker departments reporting satisfactory March business were the following: Benj. Switky (Victor), Cowperthwait's (Columbia), Blackman Talking Machine Co. (Victor and Edison cylinder), Kranich & Bach (Columbia), Hallet & Davis (Victor), Eclipse Phonograph Co. (Edison disc and cylinder).

OTILIE METZGER MAKES RECORDS

Of Her Wonderful Contralto Voice for the Columbia Graphophone Co.—A Valuable Acquisition Owing to Her International Fame.

The Columbia Graphophone Co. made one of the great conquests of the season in arranging with Mme. Otilie Metzger, the distinguished German contralto from the Hamburg Opera House, to have her voice perpetuated for the benefit of her admirers in this country through the medium of Columbia records.

Mme. Metzger has just closed one of the most successful concert tours of any artist in the United States, and has won the unanimous approval of leading critics in New York and other cities. The visit this year followed her special engagement for two appearances with the Philharmonic Society Orchestra in New York last year. She made such a favorable impression that the concert tour this year resulted.

Mme. Metzger has demonstrated conclusively her claim to a place in the front rank of lieder singers. She possesses a genuine contralto voice of great depth, power and range, which is, moreover, of unusual richness and charm. Her interpretations and diction are impeccable. Indeed her English serves as a model for our native singers, and this may also be said of her enunciation in French, as well as in German.

Such a large, vibrant, powerful voice, with its uncommon purity and capable of potent expressiveness, should afford delight to the admirers of Mme. Metzger when heard through the medium of the talking machine, for few artists have made such a host of friends as has Mme. Metzger during her present concert tour.

An unusual feature of Mme. Metzger's engagement by the Columbia Graphophone Co. was the fact that she met the representatives of the company at 9 a. m. on March 30, signed a contract at 9.30 a. m. and was recording in the company's laboratory at 10 a. m., probably breaking all records.

If you happen to think you really don't know a lot more than the boss about the business, you're probably on the way to promotion.

Send 50 cents in stamps for sample "Standard Fibre Needle Cutter." The easiest selling accessory ever offered the trade. Appeals to the women buyers. Retains chips. Artistic. Built like a watch. Compact. Powerful. Liberal discounts. Order through your jobber.

**STANDARD GRAMAPHONE APPLIANCE CO.
173 LAFAYETTE STREET, NEW YORK CITY**



ECLIPSE PHONOGRAPH COMPANY

203 Washington Street

A. W. TOENNIES & SON

Hoboken, N. J.

Jobbers of Edison Disc and Cylinder Phonographs Exclusively

Dealers of New York and New Jersey
Write for terms and discounts.



COLUMBIA GRAPHOPHONE CO'S. 25th ANNIVERSARY

Celebrated on Saturday Night at the Arcola Country Club, Arcola, N. J.—Dinner in Evening Presided Over by Edward D. Easton, President of the Company.

A party of fifty, including directors, officials and employes of the Columbia Graphophone Co., foregathered at the Arcola Country Club, Arcola, N. J., on Saturday night in order to celebrate the twenty-fifth anniversary of the founding of the Columbia Graphophone Co.

Most of the guests arrived at Arcola in the afternoon, and the club held open house indoors and out. In the evening Edward D. Easton, president of the company, presided over a dinner, at the conclusion of which many of those present

made speeches of congratulation and compliment. The feature of the evening's oratory was the large and sincere tribute paid to Mr. Easton as the man who had founded the company, and whose inspiring personality had been such a dominant factor in its development to its present magnitude. The guests included employes of the company from all parts of the country as well as England. The latter country was represented by Louis Sterling and G. L. Funnell, of London, while A. G. Farquharson, of Toronto, represented Canada.

CALL FOR DISC RECORD ALBUMS.

(Special to The Talking Machine World.)

PHILADELPHIA, PA., April 8.—The National Publishing Co., of 230 South American street, this city, is having a constantly increased demand for its disc record albums, due undoubtedly to their distinctive merits. For they are artistic in design, most durable and well finished.

Leading talking machine men throughout the country are handling them with satisfaction to themselves and to their customers, and a big trade is being built up with these albums, which are suitable for Victor, Edison, Columbia and all other makes of records.

Jobbers can greatly increase their sales to dealers by a free use of the large record album circular, which is supplied in quantities by the National Publishing Co. with the name and address of the user, as well as the prices at which the albums can be sold. Sales have been doubled by using this literature and sending it out with the regular lists of records, as well as by distributing them to callers. The circulars have four pictures on them showing the record album open and closed. These can be supplied to retailers and used to good advantage in soliciting orders.

The six-page index in every album facilitates the instant location of any record, for the labels are seen through the openings and the titles of the records can be read without removing the records.

The National Publishing Co. offers to send a sample album by parcel post for examination, so confident is it that the album will at once interest talking machine men.

A NOTABLE DINNER.

Edward D. Easton, president of the Columbia Graphophone Co., and Mrs. E. D. Easton tendered a dinner Wednesday, April 1, to Miss Gertrude Lyle, daughter of George W. Lyle, general manager of the Columbia Graphophone Co., and her fiancé, Richard Arnault, who were married at Hackensack on Wednesday of last week. The dinner was given at Mr. Easton's beautiful home in Arcola, N. J.

A noteworthy feature of this dinner is the fact that there were present four engaged couples, representing the families of Edward D. Easton and George W. Lyle. These four couples were Miss Gertrude Lyle and Richard Arnault, Miss Frances Ogden and Harold Lyle, a son of George W. Lyle; Miss Helen Easton, daughter of President Easton, and Norris Mumper; Miss Mary Rankin and Mortimer D. Easton, a son of President Easton. Other guests at the dinner included Mr. and Mrs. George W. Lyle, Mrs. Rankin, C. W. Woddrop, secretary of the Columbia Graphophone Co., and Mr. and Mrs. E. D. Easton, the host and hostess.

The table decorations were unusually tasteful and charming and each guest received an appropriate favor with a snatch of poetry contained therein. The dates of the other three weddings in these two prominent families have not yet been announced.

UTILIZING VICTOR PUBLICITY.

V. W. Moody Has Some Recent Illustrations Framed Which Tell an Impressive Story of Victor Enterprise and Advance.

V. W. Moody, sales manager of the New York Talking Machine Co., 81 Chambers street, New York, Victor distributor, recently had framed an interesting picture that makes a valuable piece of publicity for the live-wire Victor dealer. This picture shows the \$500,000 yacht "Vanadis," belonging to C. K. G. Billings, the multi-millionaire, and internationally prominent. Four views of the yacht's interior are shown, including the lounging room, the gymnasium, a bedroom and the smoking room, wherein is prominently displayed a Victor talking machine. These pictures appeared in a recent issue of the New York Sunday Times, and when framed present an artistic appearance.

Alongside of this picture Mr. Moody has displayed a number of framed colored pictures that represent to what excellent advantage the splendid publicity sent out by the Victor Co. may be utilized. One of these pictures shows the famous McCutcheon painting used in the Victor advertising in the national magazines, while others show the Christmas folder sent out last year and the group of operatic artists that has been used in the Saturday Evening Post and other national periodicals.

TALKER MEN HELD FOR GRAND JURY.

H. A. C. Howard and A. D. Pilpot, Organizers of United States Phonograph Co., Held on Charges of Fraud Brought by Railroad Man—Defendants Emphatically Deny Guilt.

(Special to The Talking Machine World.)

CHICAGO, ILL., April 13.—Following charges of fraud brought by James F. Dart, a local railroad man, who stated that they had induced him to invest money in the United States Phonograph Co. under false pretenses, Harry A. C. Howard and Albert D. Pilpot, organizers of the United States Phonograph Co., were held for the Grand Jury on Friday of last week by Judge Wells. The phonograph company retired last summer, but the defendants emphatically deny the charges of fraud and look for a speedy acquittal.

\$25,000,000 MUSEUM OF INDUSTRY

Planned in New York—Projectors Guarantee Amount for Stadium and Other Buildings.

A scheme was projected at a meeting in the Lawyers' Club, 115 Broadway, early this week for an industrial museum, to cost about \$25,000,000, to be devoted to the study of practical subjects by the public. The idea is to have a circle of buildings enclosing a stadium, the stadium to be partially covered and used for assemblage. Within the buildings would be housed permanent expositions of twenty branches of industrial and peaceful arts.

It is intended to establish the museum as a memorial of the centenary of peace among English-speaking people. Three sites are in prospect, one in an old reservoir basin in Central Park, another north of Ninetieth street and the third on property the owner of which offered it some time ago for public use by the city.

It was announced at the meeting by John A. Stewart that the financial undertaking will be one of the factors most easily handled in the development of the project, because the money can be raised among the projectors, if need be.

An association has been formed and the meeting was of the directors, those present being George F. Kunz, Frank A. Vanderlip, Charles H. Strong, A. Barton Hepburn, Calvin W. Rice, Prof. Martson Taylor Bogart, Thomas Commerford Martin and John A. Stewart. Elbert H. Gary, Henry R. Towne, Thomas A. Edison, H. E. Huntington, Theodore N. Vail and H. J. Hardenberg are among the other directors. A committee on plan and scope was appointed to report April 23.

This museum would be similar to those in Germany and France, but on a much larger scale.

THE ILLINOIS CALLOPHONE CO.

(Special to The Talking Machine World.)

CHICAGO, ILL., April 11.—The Illinois Callophone Co. has been incorporated with a capital stock of \$100,000 to sell callophones and enunciators. This is a subsidiary of the International Callophone Co. of New York, and offices will be opened May 1

The parcel post weight limit has been increased. But nothing has been done to give the purchaser of stamps by wholesale an inside price! in the New York Life Building.

TRADE REACHES NEW HIGH POINT IN MILWAUKEE.

Considerably Ahead of a Year Ago and Would Be Larger if Jobbers and Dealers Could Secure Sufficient Talking Machines and Records—A Visit to the Leading Stores Reveals a Spirit of Hustle and Optimism That Bodes Well for Summer Trade.

(Special to The Talking Machine World.)

MILWAUKEE, WIS., April 9.—The talking machine business in Milwaukee seems to be holding up unusually well, considering the fact that general business conditions are still a little quiet. Both jobbers and dealers report that trade is considerably better than at this time a year ago, while most of them believe that the outlook is good. The sales of machines and records during the month of March climbed to a new high point, and the indications are that this activity will be kept up during April.

The total volume of business up to this time this year would have been much larger but for the shortage of machines experienced with all the leading lines. Jobbers have been doing their best to get larger shipments from the factories, but they have been only partly successful, and stocks are remarkably low all along the line. The shortage seems to be especially noticeable in the Victor field and dealers handling this line say that their stocks, especially in Victrolas, are far from being equal to the requirements of the trade. Some of the leading houses have only two or three Style XI Victrolas in their stores, while the supply of Styles IX and XVI is getting low.

L. C. Parker, enterprising manager of the Victor department at Gimbel Bros.' Milwaukee store, has had his responsibilities doubled by having been made manager of the Gimbel piano department. E. S. Bridge, who has had charge of the piano sales at the Gimbel store for several years, resigned recently, and the management of the store decided that Mr. Parker had met with such remarkable success in handling the talking machine business that he was the only man to take charge of the piano department. In order that Mr. Parker might more readily handle the piano business, the department has been moved down from the sixth to the second floor, where it has been given quarters adjoining the Victor hall at the Gimbel store. Mr. Parker has built up a live, enterprising sales force and the business of both departments is climbing to a new high point.

A. G. Kunde, Columbia jobber and dealer, 516 Grand avenue, proved recently that he is a real philanthropist by donating a big Columbia machine to the patients of the Blue Mound tuberculosis sanatorium, located just west of Milwaukee. The main building of the sanatorium was destroyed by fire recently and the patients lost their talking machine, a pool table and various other means of pastime, and Mr. Kunde's sympathy was aroused.

D. C. Preston traveler in Wisconsin and Minnesota for the Talking Machine Co., of Chicago, will henceforth be a citizen of Milwaukee. Mr. Preston, whose wedding was scheduled to take place on Easter Sunday, is establishing a home of his own, and he believes that Milwaukee offers the most central location and best railroad facilities of any city in his territory.

Paul A. Seeger, manager of the Victor department at the Edmund Gram Piano House, has been meeting with such a brisk demand for Victrolas that his stock is lower than at any time since the department has been opened at the Gram store. Mr. Seeger says that the call has been especially strong for Victrolas IX, XI and XVI.

One of the display windows at the store of the Hoefler Manufacturing Co. blew in during a heavy wind storm on March 25 damaging a Victrola and an automatic piano, which were on display.

E. F. O'Neil and Sam Goldsmith, traveling representatives of the Victor Talking Machine Co., recently called upon the Milwaukee trade. W. P. Gibbs, traveler for the Rudolph Wurlitzer Manufacturing Co., of Cincinnati, O., was another recent Milwaukee visitor.

D. M. Groulx, Victor dealer at Green Bay, Wis., has established a successful branch agency at Oconto, Wis., with Oscar C. Watterich. Mr. Watterich, who is a jeweler of Oconto, is carrying a large stock of Victor goods and finds Oconto

offers an excellent field for talking machines.

The Edison line has been placed with two well-known Milwaukee houses by the Milwaukee Phonograph Co. Edison jobber in Wisconsin and Upper Michigan. Charles H. Scheff & Sons, 849 Third street, also carrying the Victor goods, have put in a full line of Edison machines and records and are featuring them in special quarters. C. Niss & Sons, Inc., one of the leading retail furniture concerns of Milwaukee, 697-709 Third street, is opening a new talking machine department and has taken up the agency for the full Edison line. It is understood that several other Milwaukee houses are negotiating for taking on the Edison line. Since the opening of the new year the Milwaukee Phonograph Co. has secured eighteen new dealers in Wisconsin for the Edison disc line.

William Idle, special traveling representative of Thomas Edison, Inc., has been in Milwaukee for some time, assisting Manager William A. Schmidt, of the Milwaukee Phonograph Co., in establishing new Edison dealers in this city. Mr. Idle expected to give a special Edison recital at the Hotel Pfister in Milwaukee on April 15, when several of the new Edison disc machines were to be featured.

Invitations were issued to several thousand Milwaukee people.

The Gensch-Smith Co., 730 Grand avenue, handling the Victor line, has met with such an increase in business since it opened its new piano department, where it features the Wurlitzer pianos and players, that it is planning on increasing its sales force once more.

Henry Sask, who has conducted a successful Columbia store at 1602 Vliet street for several years, has opened in handsome new quarters on Vliet street, between Sixteenth and Seventeenth streets. Mr. Sask has considerably more space than in his old store, while everything is new and modern. His window displays at the new store are attracting much favorable attention.

The Victor business at the Boston store during March established a new high record, according to C. W. Abbott, manager of the Victor department. The demand for high-grade machines was so strong that Mr. Abbott has been unable to keep his stock up to the normal point.

Victor sales at the J. B. Bradford Piano Co.'s store have been climbing to a high mark of late, due to the fact that every salesman in the piano department has been taking an interest in the talking machine end of the business. The salesmen are encouraged to sell all the machines that they can and most of them have been making good use of their opportunities. The Bradford house regularly gives up half its window display room to exhibiting the Victor goods.

WE DON'T—DO YOU?

Do You Believe These Claims?

What does it mean to say, "We are the largest"—"We are the best"—"We always ship complete the same day," etc., etc.?

"Bosh"—Idle, Careless Claims

Who wants them? We don't know who is the "BIGGEST," etc., because it is not possible to get the details of a competitor's business.

You Want A Jobber to "Make Good"

We are here to SERVE YOU and have you JUDGE by what WE DO.

Try It Now—Send An Order

Let it be MACHINES or RECORDS. Don't let your Competitor be a "BLACKMAN DEALER" at your expense.

Very sincerely

BLACKMAN TALKING MACHINE CO.

J. NEWCOMB BLACKMAN, Pres.

97 CHAMBERS ST., NEW YORK



RETURNS FROM ORIENTAL VISIT.

E. E. Robinson Places Important Columbia Agencies in Java, Ceylon, Singapore, Hong Kong and North China—Pleased with the Results of His Trip—Trade in Hawaii Expanding—Recuperating After His Extended Trip.

E. E. Robinson, one of the Columbia Co.'s traveling representatives in its export department, returned to New York late last month after nearly a year's trip to various parts of the Orient. While this was Mr. Robinson's first extended trip since he joined the Columbia export department some time since, he achieved a very pleasing success, establishing several important new connections and



E. E. Robinson.

securing large-sized orders that indicate the popularity of Columbia records and machines in this part of the world.

Among the countries Mr. Robinson visited was Java, where he placed a number of new agencies for Columbia products, particularly for the sale of native records. In Java one class of dealers handles the usual types of machines and records, while other dealers concentrate on native records, for which there is a large demand. At Ceylon Mr. Robinson closed arrangements with one of the best known retail merchants in that country to handle the Columbia line. At Singapore he also made a valuable connection for both native and English trade.

At Hong Kong, one of the greatest ports in the world, Mr. Robinson established a new Columbia agency which promises to be a very successful and prosperous one. In North China Mr. Robinson found that Mustard & Co., Columbia dealers for this territory, had been closing an excellent busi-

ness both in machines and records, and notwithstanding the difficulties of transportation, had sent Columbia machines far into the interior, sometimes on the backs of camels. Columbia products in Hawaii are maintaining a long-established popularity that bids fair to be steadily augmented in future years.

VICTROLAS IX AND X IN FUMED OAK.

The Victor Talking Machine Co. made the following announcement last week, which is of considerable interest to all the company's distributors and dealers:

"To meet a growing demand, due to the steady increase in popularity of the fumed oak finish in home furnishings, we have decided to furnish the Victrolas IX and X in fumed oak." We probably will be in a position to make shipments in this finish some time in June, but suggest that the dealers and distributors place their orders immediately so that we may determine to some degree what percentage of our output to devote to this finish."

The machines referred to in the above letter, Victrolas, Nos. IX and X, are among the most popular models in the Victor catalog, retailing at \$50 and \$75 respectively. These machines in fumed oak finish should prove welcome additions to the Victor dealer's line.

INCREASE FLOOR SPACE.

The Columbia Co.'s wholesale establishment at 89 Chambers street, New York, has found it necessary to increase its floor space to adequately handle its fast growing business. To this end a half of another floor in the same building was leased this week. This extra room will be used for storing purposes, permitting of the store's keeping considerably more stock on hand than is now possible with its present floor space.

SECURE IMPORTANT CONTRACT.

New York Board of Education Closes Contract with Columbia Co. for Supplying Graphophones and Records to the Public Schools—Initial Order Is for Sixty Machines.

The educational department of the Columbia Graphophone Co. has been awarded the contract by the New York Board of Education for supplying the New York public schools with graphophones and records during 1914. The Columbia department secured this contract last year, and



Columbia Machine in Use by New York School on Field Day.

supplied a large number of Columbia school Grafonolas and Columbia records to many of the local schools. That this school equipment gave perfect satisfaction in every respect is indicated by this new contract for the 1914 equipment. An initial order for sixty Columbia school machines and an adequate supply of records was received by the Columbia Co. last week.

In discussing the awarding of this important contract, Frederic Goodwin, head of the Columbia Co.'s educational department remarked as follows: "We are naturally greatly pleased to receive the contract for furnishing the school equipment for the New York schools during 1914. In view of the fact that Columbia school product was used in

Mr. Robinson is now recuperating from the strain of his long and arduous trip, which although it was a very successful one, was naturally fatiguing and tiring to a degree. Needless to say, Mr. Robinson returned to this country a still more enthusiastic admirer of and believer in Columbia goods than when he left these shores a year ago.

TAYLOR'S VICTROLA STORE.

In Jackson, Miss., Is One of the Liveliest and Most Successful in That Section—Doing an Enormous Business with the Victor Products—Catering to a High Class Trade.

(Special to The Talking Machine World.)

JACKSON, Miss., April 6.—One of the liveliest talking machine concerns in this section of the State is Taylor's Victrola Store at 244 East Cap-

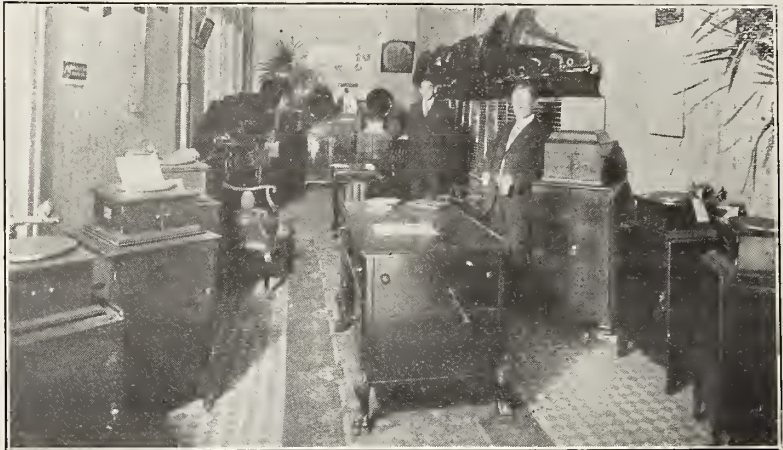

M. E. Taylor's Store in East Capitol Street, Jackson, Miss.

tal street, this city, of which M. E. Taylor is proprietor.

Mr. Taylor has been in the talking machine business for about ten years, most of that time as manager of the department for the E. E. Forbes Co., in this city, and when that concern closed out the local branch Mr. Taylor took over the talking machine department under his own name. He carries a complete assortment of machines and records and caters to a high-class trade with much success. Incidentally, it may be stated Mr. Taylor is an enthusiastic reader of The Talking Machine World, from which he has received great benefit in many ways.

the local schools in 1913, we are convinced that the recent school award to our company was based on the excellent service that we rendered during 1913. The New York school contract is, in my opinion, the most important school contract in the country, and the recognition of Columbia prestige and service is indeed a gratifying tribute to our progress in this special division of our business.

"This award indicates conclusively the realization by boards of education and educational authorities that the talking machine is an indispensable article in the school room as an educational

factor, and not merely as an entertainment. Our slogan from the very start of this department has been to impress upon the school authorities the educational value of the Grafonola in the school room. The entertainment feature was but a minor consideration in our estimation, and by continually aiming to emphasize the true educational value of the Grafonola we have secured prestige and standing in the eyes of the school world that we would otherwise have been impossible to secure. Columbia dealers throughout the country should use this New York award to excellent advantage, as the recognition by the New York school authorities of the value of Columbia school products is worthy of the widest publicity."

Talking Machine Dealers

Who are desirous of adding new features to their line should consult

The Music Trade Review

This is the oldest music trade publication in this country, having appeared without interruption since July, 1879.

It is published every Saturday, and contains a thorough and exhaustive resume of all departments of the music trade industry.

Its editions vary from 60 to 150 pages.

It is conceded to be the most influential paper representing the music trade, and if you are interested in the topics with which it deals, do not fail to receive this paper regularly.

Ask for a sample copy.

Regular subscription price is \$2 per year.

EDWARD LYMAN BILL
EDITOR AND PROPRIETOR

373 Fourth Ave., New York

TO MANUFACTURE IN GERMANY.

E. N. Burns Who Recently Returned from Europe States Plant Has Been Secured at Biersfeld, Saxony, to Make Columbia Machines to Supply the Trade in All Points Outside the United States—Columbia Business Active in Europe, Says Mr. Burns.

Edward N. Burns, vice-president of the Columbia Graphophone Co. and manager of the company's export department, who returned to New York late last month after a three months' trip abroad, made the important announcement this week that the Columbia Co. had completed arrangements to manufacture machines in Germany to take care of the demands of its export trade. These machines will be ready for shipment some time this month,



One of the "Columbia-Europa" Styles.

and will be distributed to Columbia dealers in all parts of the world outside of the United States.

The Columbia factory abroad is located in Biersfeld, Saxony, Germany, in the "Black Forest," where manufacturing and shipping facilities are ideal. This factory is now working to full capacity both day and night, and sample machines were brought over by Mr. Burns on his trip home.

These machines, which will be known as the "Columbia-Europa" product except in England, where they will bear the name of "Regal," are designed to permit Columbia dealers to successfully compete with the cheaper types of machines made in Europe at the present time, and will be furnished in two styles, horn and hornless. One attractive model that is undoubtedly destined to achieve world-wide popularity sells at \$3 net for the hornless machine and \$3.50 net for the horn machine, f. o. b. Bremen or Hamburg.

The machines will be furnished in three colors—mahogany-colored cabinet with brown panel and mahogany-colored horn; oak-colored cabinet with oak panel and oak-colored horn; black cabinet with a light panel or one with gold medallions carrying a dark red or black horn. These panels are ten centimeters in width and encircle the entire body of the cabinet, and the horns are decorated with gold lines. The machines are packed in individual corrugated containers and will be packed twenty to a case. The horns will be packed sixty to a case. There are at present six models in the Columbia-Europa line and four more will probably be added in the near future. One of these will probably be cheaper than the \$3 model, while the others will be more expensive. The machines carry a ten-inch turntable and the motor will play a twelve-inch record. Coincident with the introduction of these new Columbia machines for export trade the following machines are withdrawn from export distribution: BZ, list \$17.50; BWT, \$18 list, and Harmony, \$15 list.

"These machines will be carefully made in every particular," said Mr. Burns, "and will afford the Columbia export trade a splendid sales proposition that will give them substantial profits and place them in a position to meet any and all competition.

"Business conditions in Europe are generally satisfactory. Our London house closed the best year it ever experienced, while our business in Austria Hungary was very gratifying. Europe is fast recovering from the disastrous effects of the Balkan wars and the outlook is decidedly encouraging.

"American music is scoring an emphatic success abroad, and wherever one goes, England, France

or Germany, the popular American songs are the ones that are continually heard. For example, on one song, 'You Made Me Love You,' over 250,000 records were sold, making it one of the best selling records ever introduced."

NEEDLE COMPANY INCORPORATES.

The Velvetone Wood Needle Co., 509 Hall Building, Kansas City, Mo., has been incorporated with a capital stock of \$20,000 for the purpose of manufacturing and marketing a new form of wood talking machine needle. The officers are: F. Alexander, president and manager; Clarence Alexander, vice-president, and O. A. Schramm, secretary and treasurer.

Clifford R. Ely, the popular traveling ambassador for the Columbia Co.'s wholesale department, left Sunday night for an extended trip through the South. Mr. Ely has been spending the last few weeks in New York, and during this time had closed arrangements with a number of prominent

local concerns in various mercantile lines to handle the Columbia products.

SUPPORT THE STEVENS BILL.

Dealers Should Write Their Senators and Congressmen in Favor of Fair Trade Principles.

The Victor Talking Machine Co. sent out a letter to its dealers this week calling their attention to the importance of the measure now before Congress known as the Stevens bill (H. R. 14,305). The letter to the Victor dealers reads in part:

"You know, of course, how important it is that this bill should become law, as it would be national recognition of the fair trade principle, and effective prohibition of the predatory price-cutting methods that are ruining so many dealers and creating trade monopolies. We trust that you will promptly take similar action and write immediately to your Senators and Congressmen in favor of this bill, mentioning it by name and number—Stevens bill (H. R. 14,305)."

Announcing the Pathéscope

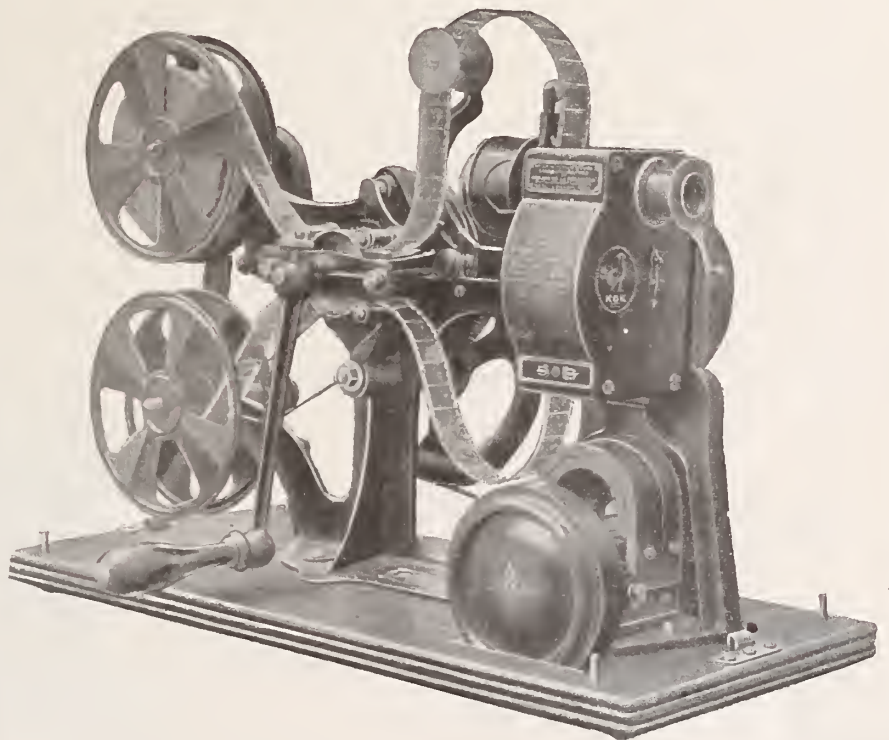

YOUR ATTENTION IS RESPECTFULLY INVITED TO THE LATEST AND GREATEST INSTRUMENT FOR HOME ENTERTAINMENT, INSTRUCTION AND AMUSEMENT—

THE PATHÉSCOPE,—A DRAWING ROOM CINEMATOGRAPH.

THIS INSTRUMENT, FOR THE PROJECTION OF MOTION PICTURES, RECENTLY INVENTED BY MESSRS. PATHÉ FRÈRES, OF FRANCE, CONSTRUCTED WITH THE SKILL AND PRECISION OF FRENCH ARTISANS, BEING SELF-CONTAINED, THE LIGHT INCANDESCENT, THE FILMS NON-INFLAMMABLE, INSURES THE SIMPLICITY AND SAFETY WHICH ENABLES ITS EFFECTIVE OPERATION BY A CHILD. IT IS PARTICULARLY APPRECIATED BY AN INTELLIGENT AND DISCRIMINATING CLIENTELE, WHO DESIRE TO GRATIFY THEIR INDIVIDUAL PREFERENCE IN THE SELECTION AND ENJOYMENT OF THE BEST IN CINEMATOGRAPHY—CONSTANTLY AVAILABLE TO EVERY OWNER THROUGH THE PATHÉSCOPE FILM EXCHANGE.

FOR DEMONSTRATIONS OR CATALOGUES, ADDRESS
PATHÉSCOPE, SUITE 1632, AEOLIAN HALL, NEW YORK

THREE NEW VICTOR ARTISTS.

Emmy Destinn, Lucrezia Bori and Julia Culp to Be Represented by Important Musical Numbers in the Victor Library.

The Victor Talking Machine Co. has just closed arrangements with Emmy Destinn, the famous soprano of the Metropolitan Opera Co.; Lucrezia Bori, the new soprano of this same prominent opera company, and Julia Culp, the great Lieder singer, and announces that these internationally prominent artists will record exclusively for the Victor Red Seal library. The first recordings of these celebrated artists will be announced in a supplement of the Red Seal catalog to be issued in the near future.

Emmy Destinn's first Victor recordings consist of a lovely air from the first act of "Mignon" and a highly dramatic air from Act II of "Madame Butterfly." Both of these selections are admirably well suited to Mme. Destinn's beautiful soprano voice, which is heard at its best in these two familiar and popular operatic airs.

Lucrezia Bori, the popular operatic soprano, is well known both here and abroad, her interpretations of many difficult soprano roles having been highly praised by musical critics. Her latest success at the Metropolitan was the portrayal of the wife in "L'Amore die tr re," in which she scored one of the greatest successes in the history of opera in America. Mme. Bori has chosen for her first Victor records two numbers from Verdi's "Traviata" and Leoncavallo's "Pagliacci," both of which are charmingly sung.

Mme. Julia Culp, the distinguished Holland mezzo-soprano, has won fame on the concert stage in all parts of the world, and famous critics have praised her warm, rich tones in the most eulogistic terms of appreciation. Mme. Culp has chosen for her first Victor recordings a favorite German cradle song and an old English ballad, "Drink to Me Only," which is exquisitely sung in the clearest of English, while the singer's rendering of Brahms' beautiful "Lullaby" is a tender and lovely one.

AGAINST FALSE STATEMENTS.

National Association of Credit Men Back of New Federal Bill That Would Prohibit the Mailing of False Statements for Purposes of Obtaining Credit—Text of the Bill.

The National Association of Credit Men, which was largely responsible for legislation strengthening the bankruptcy law, has recommended to Congress the enactment of a law prohibiting the transmission through the mails of false statements for the purpose of procuring credit. A bill (H. R. 14,328) to that effect has just been introduced by Representative Sabath. It reads as follows:

"That any person who shall deposit or cause to be deposited in any post office or station thereof, branch post office or street or other letter box of the United States, or authorized depository for mail matter to be sent or delivered by the post office establishment of the United States, or shall knowingly cause to be delivered by mail according to the direction thereon, any letter, writing or circular containing or being a materially false statement and known by him to be materially false respecting the financial condition or means of himself, or any other person, firm or corporation, in whom he is financially interested or for whom he is acting, for the purpose of procuring, either from the person, firm or corporation to whom such statement shall be delivered or addressed, or from any other person, firm or corporation, either the delivery of personal property, the payment of cash, the making of a loan or credit, the extension of a credit, the discount of an account receivable, or the making, acceptance, discount, sale or endorsement of a bill of exchange, or promissory note, for the benefit either of himself or such person, firm or corporation in whom he is interested or for whom he is acting, shall be punished by a fine of not more than \$5,000 or by imprisonment of not more than one year, or both by fine and imprisonment, at the discretion of the court."

The National Association of Credit Men, in conjunction with the American Bankers' Association

in 1909, prepared a draft of the so-called uniform false statement law. This statute, substantially in the model form, has been enacted in New York, California, Connecticut, Delaware, Indiana, Louisiana, Maine, Missouri, New Jersey, Pennsylvania, Rhode Island, Utah and Vermont. In other States there are in force statutes dealing with this question, though differing considerably from the model statute. Until such time as the uniform statute has been generally adopted the false statement act by States, while adequate in punishing offenses wholly within a State having the law, is not protective against false statements in interstate commerce, which is usually consummated through the agency of the mails. This difficulty, it seemed to the association, could best be met through the enactment of a law by Congress prohibiting the transmission through the mails of false statements in writing for the procuring of credit thereon.

HOLD GRAND OPENING.

Cowperthwait & Co. Celebrate Opening of Its Talking Machine Department.

Cowperthwait & Co., the prominent furniture house with stores at 103 Park Row and 121st street and Third avenue, New York, held the grand opening of its new Columbia department on April 4. Edward Woolley, connected with the Columbia Co. for several years, has been appointed manager for the two departments, and his lengthy experience with Columbia policies and products well equips him to achieve a pleasing success in his new position. The Columbia department in the uptown Cowperthwait store is an unusually attractive one, the company having spent considerable money to make the numerous demonstration rooms sound-proof and artistic. Cowperthwait & Co. cater to an extensive and fast-growing clientele, and should find Columbia machines and records a valuable addition to their business.

Some men believe the almanac; some think the weather bureau accurate; still others have a hunch that this year the home baseball team's going to win the pennant, you betcha!

THE "OGDEN" RECORD SECTIONAL UNIT and FILING SYSTEM

The First and Only Satisfactory Record Cabinet on the Market. Simple and Inexpensive.

THE most complete record filing system ever offered. It enables you to file records so you can put your hands on any record in stock in four seconds. Equipped with spring in each compartment that holds all records in upright position regardless of quantity of records filed and keeps them from warping.

Simple, adjustable signal system for quick filing and keeps record of duplicates before you at all times. Enables you to put your hand on any kind of record without reference to catalog, and work off dead records.

Requires small space and has big record capacity. Cut shows three-section cabinet, each section having 300 record capacity. Accessory and supply drawer at base. Base furnished without legs if desired.

Whether you stock the full catalog or just a few records you need this cabinet—and you need it now! Cabinets finished in all standard woods.

Write for Descriptive Folder and Price List.
Special Proposition Offered Jobbers.

J. B. OGDEN Lynchburg, Va.

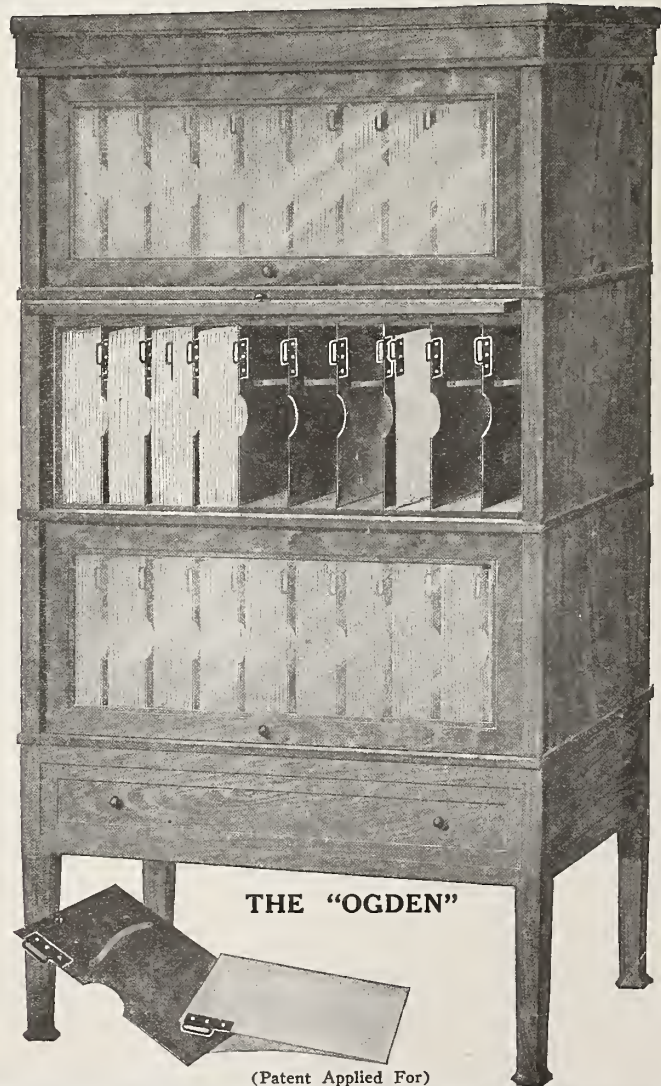

THE "OGDEN"

(Patent Applied For)

ENTER JOBBING FIELD IN NEW YORK.

Phonograph Corporation of Manhattan, Recently Incorporated, Opens Wholesale Headquarters at 433 Broadway, with Frank K. Dolbeer in Charge as Manager—To Handle the Entire Edison Line at Wholesale—Retail Quarters to Open on Upper Fifth Avenue.

Frank K. Dolbeer, for the past fifteen years manager of phonograph sales for Thomas A. Edison, Inc., and its predecessor, the National Phonograph Co., and who is well known and popular in the trade throughout the country, resigned recently from that position for the purpose of becoming manager for the recently organized Phonograph Corporation of Manhattan, jobbers and retailers of Edison machines and records in New York City.

As recently announced in The Talking Machine World, the new company, which has the backing of Chicago and New York capitalists, has leased the building at 473 Fifth avenue, in the heart of the exclusive musical and business district near Forty-second street, of which possession will be taken on May 1. Contracts are now being let for the re-



F. K. Dolbeer.

modeling of the structure throughout in a most elaborate manner, with a conspicuous but artistic tile front, a commodious recital hall in the rear of the first floor and other fittings in keeping. The cost of the work will be in the neighborhood of \$50,000, and it is expected to be finished in time for the company to occupy the quarters about the middle of August.

The Phonograph Corp. of Manhattan has already taken possession of a large floor at 443 Broadway, running through to Mercer street in the rear and including over 10,000 square feet of floor space, which will be used as a storage and shipping center for the jobbing end of the business. Only sufficient goods will be carried in stock at the Fifth avenue quarters to meet the demands of the retail trade.

Mr. Dolbeer and G. L. Babson, one of the Babson family of Chicago, well known in the phonograph trade, his assistant, opened for business at the Broadway address on April 6. A stock of sample instruments were placed upon display at once and shipments of disc and cylinder machines and records have been coming from the factory in a steady stream since that time. A number of pleasing orders for goods were received from local Edison dealers during the first week, and Louis F. Barg, of 7810 Third avenue, Brooklyn, was the first dealer to be signed up by the new company.

In speaking of the plans of the Phonograph Co., of Manhattan, Mr. Dolbeer said: "New York is practically a virgin territory for the exploitation of the Edison phonographs and records of the newer types, and it is the plan of our company to go after the business in a most aggressive manner. When our uptown quarters are opened the offices of the company will move to that address and a campaign of advertising will be carried on in the broadest sort of way and in a manner that will not only aid our own business, but will tend to benefit materially the business of every concern in New York and vicinity handling the Edison products. From our own experience and that of other Edison jobbers already established we are on the threshold of a new era in the talking machine trade."

DINNER TO FRANK K. DOLBEER.

Tendered a Farewell Banquet by the Heads of the Various Departments of Thomas A. Edison, Inc., Upon His Resignation as Manager of Phonograph Sales for the Company.

The esteem in which Frank K. Dolbeer is held by his former associates with Thomas A. Edison, Inc., was indicated on Saturday evening, April 4, when, following his resignation from the post of manager of phonograph sales for that company, which he held for fifteen years, to become manager of the newly organized Phonograph Corp. of Manhattan, the heads of the various departments of the Edison Co. to the number of thirty-six tendered him an elaborate farewell dinner at the Hotel Washington, Newark, N. J.

During the course of the dinner Mr. Dolbeer was presented with a handsome gold watch of the latest model, suitably engraved, which was accompanied by a valuable chain of platinum, set with pearls. The presentation speech was made by Charles H. Wilson, vice-president and general manager of Thomas A. Edison, Inc., to which Mr. Dolbeer responded and expressed his sincere appreciation in his usual enthusiastic manner.

Wm. H. Meadowcroft, who has been private secretary to Thomas A. Edison for the past thirty-five years; E. H. Phillips, credit manager, and N. C. Durand, manager business phonograph department, made brief speeches. At the conclusion of the dinner Mr. Dolbeer was the recipient of an elaborate autographed menu, which contained a photograph of Mr. Dolbeer, with a little history of his life, and "moving pictures" of some of the striking moments of his career.

The dinner broke with the drinking of the following expressive toast:

Here's to you, Frank Dolbeer,
Here's to you, our jovial friend!
And we'll drink the toast before we leave the company,
We'll drink before we part,
Here's to you, Frank Dolbeer.

A. C. IRETON PROMOTED TO MANAGER

Placed in Charge of Phonograph Sales Department of Thomas A. Edison, Inc.

A. C. Ireton, who has been connected with the Edison phonograph interests for seventeen years, most of that time as assistant to the manager of phonograph sales, has succeeded Frank K. Dolbeer as head of the phonograph sales department, following the recent resignation of the latter to be-

come manager of the Phonograph Corp. of Manhattan. Mr. Ireton is well known to the Edison jobbers and dealers throughout the country and is well fitted to fill his new and responsible position in a most capable manner.

DEATH OF GEORGE A. LONG.

Head of Long Furniture Co. and George A. Long Cabinet Co., Hanover, Pa., Passes Away After a Brief Illness—A Prominent Business Man and Citizen—No Change in Conduct of Business.

(Special to The Talking Machine World.)

HANOVER, PA., April 3.—George A. Long, head of the Long Furniture Co., and of the George A.



George A. Long.

Long Cabinet Co., of this city, died at his home here last week after a very short illness. He was fifty-six years old and was born in Hanover, where he spent his entire lifetime.

The Long Furniture Co. was established thirteen years ago and the George A. Long Cabinet Co. was organized several years later for the purpose of making talking machine cabinets for the prominent manufacturers and also record cabinets for the general trade. With both classes of cabinets the company met with particular success, due largely to the business ability of Mr. Long in manufacturing and marketing his product.

Mr. Long was one of the most prominent citizens of Hanover, took a lively interest in the civic and social affairs of the city. He was one of the organizers of the Hanover Trust Co., a member of the Masons and other orders, and a pronounced lover of music, which influenced him to organize the local choral and oratorio societies.

Mr. Long was highly respected by his friends and associates as a man of high principles and whose word was as good as a written contract in any transaction. The funeral on Tuesday was largely attended.

The business of both the Long Furniture Co. and the George A. Long Cabinet Co. will continue as before the death of Mr. Long with Clement Beechcroft continuing to represent the latter company in the talking machine trade.

UNION SOUND BOX

PRICES:
Gold plated, \$5.00.
Nickel, or oxidized, \$4.00.

UNION No. 1
Patent No. 776-672, others pending.

PRICES:
Gold plated \$5.00
Nickel or oxidized..... 4.00

UNION NEEDLE BOX for Edison Machine.

PRICE:
Finished in Mahogany, Circassian Walnut or Fumed Oak, any finish, 50c.

4

EASY SELLERS—

At the left is the new UNION Sound Box just out, taking Fibre or any make of needle. It is the latest improvement in sound reproduction, and fits all Disc Machines.

UNION TALKING SPECIALTIES

The upper right-hand illustration shows UNION No. 1, for playing Columbia and Victor records on Edison Machines. UNION No. 1 contains the UNION Modifier feature. The lower right-hand illustration shows the UNION Modifier, a quick-selling device, giving Edison, Victor and Columbia owners absolute control over the volume of sound. The UNION NEEDLE BOX fills another long-felt want.

Write to-day for descriptive folders and prices on these four easy-selling specialties. List prices shown here, usual discount to dealers

All persons selling goods infringing our patents are liable to suit for such infringement.

THE UNION SPECIALTY AND PLATING CO.

409 Prospect Ave., N. W. Cleveland, Ohio

WRITE FOR NEW FOLDERS

PRICES:
Gold plated, \$1.50
Nickel or oxidized... 1.00

What Vernon Castle says and Columbia

COLUMBIA GRAPHOPHON

Gentlemen:—"I want
dance records you have recently
heard. I am using a
Columbia Records at Castle
extraordinary attention. The
dance time and are frequently

and when Mr. Castle writes
in our

Columbia Graphophone Company
Woolworth Building, New York





of Columbia Grafonolas dance records

CO.

gratulate you on the excellent
issued; they are the best I have
mbia Grand Grafonola and
use, where they are attracting
records are played in perfect
ored by our patrons."

Ermon Castle

ote this letter he was not
employ



Creators of the talking machine industry. Pioneers and leaders in the talking machine art. Owners of the fundamental patents. Dealers and prospective dealers, write for a confidential letter and a free copy of our book, "MUSIC MONEY."

A COMPANION EDUCATOR

To the Talking Machine is the Pathscope, a Compact Home Cinematograph—Will Interest Trade—Chat with Willard S. Cook.

Many talking machine dealers in New York and nearby territory recently visited The Pathscope

dealers from Maine to California, and we are enthusiastic over the future of the Pathscope in this country."

Mr. Cook also pointed out that the Pathscope, by means of an ingenious arrangement, generates its own (incandescent) electric light. This is done by the simple action of turning a handle. Other



The Pathscope in Operation—An Entertainer and Educator.

Salon in Aeolian Hall, 33 West Forty-second street, New York, in response to an invitation sent out by Willard B. Cook, manager of this salon. The Pathscope, which is a very simple and compact home cinematograph, is manufactured by Pathé Frères, the world-famous moving picture house, and has already achieved considerable popularity abroad.

In a talk with The World Mr. Cook remarked that the talking machine dealer furnishes the ideal distributor for the Pathscope, as it forms a companion entertainer to the better grades of talking machines. "While investigating the sales of Pathscopes in Great Britain and France, where many thousands are in daily use, I found that the dealers in talking machines were the most successful distributors. After a year spent abroad, I came back convinced that the Pathscope will become as popular here as the phonograph. Our first shipment was sold out before it arrived here, and the cable order we placed for the second shipment has already been doubled. Inquiries are coming from

larger models for use where electricity is available take current from any electric light socket, doing away with the use of a crank. The Pathscope uses a special narrow-width film that is absolutely non-inflammable and may be handled without the slightest danger, which is responsible for its being approved for home use by the fire authorities. The owner of a Pathscope may exchange films purchased with the machine as often as desired by the payment of a small fee through the Pathscope film exchanges which are being established in all principal cities.

A BUSY NEEDLE FACTORY.

Plant of John M. Dean Corporation in Putnam, Conn., Forced to Work Nights to Meet Demands for Products of This House.

(Special to The Talking Machine World)

PUTNAM, CONN., April 10.—"We have been running nights until 10 o'clock trying to keep up with our orders, but are still a little behind on them as

LONG CABINETS

Occupy a strong position

The Geo. A. Long Cabinet Co.

PUSH THE SALE OF RECORDS BY SELLING CABINETS

Write for Circulars of
RECORD CABINETS
and
PLAYER ROLL CABINETS

Address

Clement Beecroft, Sales Manager

309 W. Susquehanna Avenue
PHILADELPHIA, PA.

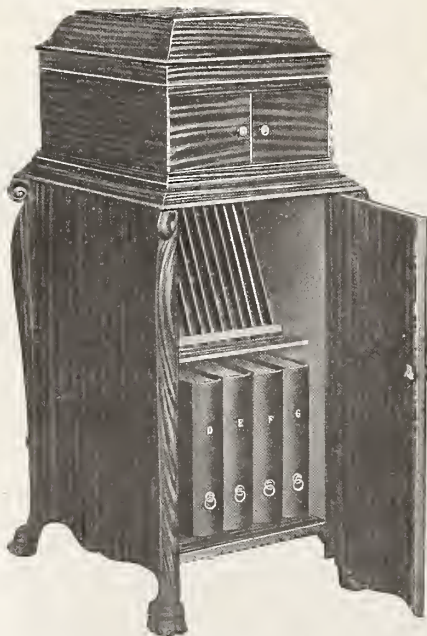

D 64

Mahogany, Golden Oak and W. O.
Finished all around.
For IX Victrolas.
Capacity 180 12-inch Records.

The Winner of The Columbia \$250.00 Prize

In the January issue of The Talking Machine World the Columbia Graphophone Co. offered a \$250 prize for the best suggestion made by any World reader, following which it would be possible to secure closer and more profitable relations between manufacturer and dealer.

The offer included every dealer in the United States and Canada, and it afforded an opportunity to get original, co-operative suggestions into a definite, concrete form.

Inasmuch as I was appointed by the Columbia Graphophone Co. to act as a judge in the matter, I have concluded, after going over hundreds of letters received, that H. W. Gray, of Wilton, N. Dak., should be awarded the prize.

EDWARD LYMAN BILL

yet. The first three months of this year have been the best in the history of the concern. We believe our output is now the largest of any organization in the world that is devoted to the manufacture of talking machine needles."

If anybody wants to see optimism in the talking machine business the foregoing example of the John M. Dean Corporation, of this city, shows that the energetic work being done by this house is proving resultful.

The Dean Corporation is making a specialty at the present time of its improved half-tone and loud tone needles in new style envelopes. It will put a jobbers name on these envelopes or will pack them in Puritone envelopes, guaranteeing the quality. It also features the "Dean-packed" needles, in which 1,000 are sold at a time instead of 100, for there are five boxes of 200 each, extra loud, loud, opera, medium and soft, all packed in one carton.

MANUFACTURE A LARGE LINE.

The Triumphon Co., Ltd., of Berlin, Makes Not Only an Immense Line of Talking Machines, but Accessories of All Kinds for Present or Prospective Manufacturers.

(Special to The Talking Machine World.)

BERLIN, GERMANY, March 30.—One of the busiest concerns in this country, devoted to the manufacture of supplies and talking machine accessories, is the Triumphon Co., Ltd., of this city, who has long made a specialty of supplying motors, sound boxes, tone arms, as well as complete talking machines built along novel and interesting lines.

They turn out forty different models of complete talking machines, with or without horns, giving expression to almost every line of taste. Their advertisement (which appears on page 41 of this issue of The World) is well worth reading, as those engaged in the manufacture of talking machines will find news of interest therein. The Triumphon Co. claim to meet all competition in the matter of price, quality and facility of output. A new catalog, No. 32, has been gotten out by this company in the English language, which will be sent to those interested on request.

GREAT TRIBUTE TO THE VICTROLA

As an Educational Developer in the School Room Paid by Ernest G. Hesser, Supervisor of Music in the Schools of Pasadena, Cal.—Details of Great Work Accomplished.

With the rapid strides which the educational department of the Victor Talking Machine Co. has been making in the short while that it has been established, it is indeed pleasing to note that this

shown in use in the school room of a large school in Pasadena, Cal., where it is assisting the teacher in telling the children the story of "Lohengrin." The teacher is personally explaining the story of this famous opera and by throwing the scenes from the opera on the screen and accompanying it on the Victrola, is giving a detailed lesson on this opera which is being greatly appreciated by the pupils.

In connection with this photograph, Ernest G. Hesser, supervisor of music in the schools of Pas-



Using the Victor to Explain "Lohengrin" in Pasadena School.

department is in daily receipt of photographs accompanied by letters of appreciation, portraying in detail how the Victrola is being used in school rooms from coast to coast. These photographs indicate clearly the practical value of the Victrola in the school room as an educational factor, and the endorsements by the supervisors of music and individual teachers signify impressively the co-operation which exists between the educational authorities and the school room talking machine.

In the accompanying illustration a Victrola is

adena, has written the following letter of appreciation to the Victor Talking Machine Co.:

"Last year I put five Victrolas and five sets of records into our twenty grammar schools, one school keeping it a month and then moving it on to another. This year two of the schools have bought their own. They have been of special value in our seventh, eighth and ninth grades, or intermediate schools, where we study the musical forms, both vocal and instrumental. After the music form has been explained then we illustrate with the best records. The use of the Victrola has made this study of forms very interesting to the children.

"We also use them for folk dancing and marching, and for general culture work in all the grades from the kindergarten on up. They are also used at our parent-teacher association meetings both for culture and enjoyment.

"It has been of great value to the teachers and to me personally in that it has brought such a great wealth of music literature to us and, too, so much that we do not often hear. It is the greatest educational device of the age.

"I have been giving our pupils in the upper grades something new—I think it is original, at least I have not heard of it being done elsewhere. After having finished with the explaining of all the component parts of grand opera, then telling the children the story of "Lohengrin" act by act and throwing the scenes from the opera on the screen (lantern) and accompanied with the Victrola, giving the music that goes with the picture. It has been very successful—not only the children enjoying it, but the parents have turned out and filled our auditorium. I will send you a picture of this work which shows the class of eighth grade pupils, the lantern, screen, Victrola, etc. (Signed) Ernest G. Hesser, Supervisor of Music."

J. H. BECKER WITH HOEFFLER CO.

(Special to The Talking Machine World.)

MILWAUKEE, Wis., April 7.—J. H. Becker, Jr., one of Milwaukee's best known talking machine men, has returned to the Hoeffler Mfg. Co., 306 W. Water street, where he has assumed his former position of general manager of the talking machine department, where the Victor line is featured. Mr. Becker, who has been engaged in the talking machine business in Milwaukee for the past ten years, has been away from the Hoeffler house for the past two years, during which time he has been manager of the Victor department, formerly conducted at the Espenhain department store, and manager of retail sales for Miss Gertrude Gannon.

NEW EDISON STORE IN MILWAUKEE.

Milwaukee Phonograph Co. Formally Opens Handsome New Quarters at 213-215 Second Street, That City—More Than 2,000 Visitors.

(Special to The Talking Machine World.)

MILWAUKEE, Wis., April 7.—The Milwaukee Phonograph Co., jobber for the Edison line in Wisconsin and Upper Michigan, formally opened its handsome new retail Edison store at 213-215 Second street on March 21. More than 2,000 people visited the establishment, and the Edison line has been given such wide publicity in Milwaukee that sales of machines and records climbed higher during the first two weeks than Manager William A. Schmidt had ever anticipated. The honor of making the first sale on the opening day went to Miss Margaret Schumacher, office manager of the Milwaukee Phonograph Co. The machine was a \$250 Edison disc and was sold one hour after the store was opened.

True to the predictions of Manager William A. Schmidt, the new Edison store proved to be something entirely different and more elaborate than any retail talking machine establishment ever opened in Milwaukee. More than \$7,000 was spent in remodeling and in the fixtures and decorations. The fixtures and woodwork are in silver gray oak and the interior of the store shows excellent taste. The general color scheme is black, gray and gold. The walls in the main demonstration room and in the various other demonstration parlors are covered with silk tapestry, while the stencil work on each panel is different and is done in six different colors.

The various lighting fixtures are of special design and have attracted much favorable comment. The entire work of arranging the store and providing the fixtures was done by the Niedecken-Wallbridge Co., interior architects of Milwaukee.

There is more than 15,000 square feet of floor space in the two floors. Five large demonstration rooms, the offices and shipping rooms take up the first floor, while the second floor is given up to the warerooms of the wholesale department of the Milwaukee Phonograph Co.

The new retail department is in charge of Frank Tipton, formerly with the Phonograph Co., of Chicago, although William A. Schmidt, manager of the Milwaukee Phonograph Co., has general supervision. Three new sales people have been added, while the office force has been increased.

VISITING THE UNITED STATES.

(Special to The Talking Machine World.)

LONDON, ENGLAND, April 5.—Two prominent graphophone men left these shores March 28 on a few weeks' visit to the States. They are Louis S. Sterling, British manager, and G. L. Funnell, works manager, of the Columbia Graphophone Co., London. They were given a hearty send-off by a select gathering of trade friends who journeyed to Waterloo for that purpose.

NATURE OUTDOES TALKER MAN.

Benjamin Switky, the well-known local Victor distributor, sends the following characteristic paragraph on a postcard from Hamilton, Bermuda, where he is spending a short vacation with his family: "Nature has been so wonderfully kind and generous to Bermuda that local talking machine men find it hard to interest the people in man-made wonders." Incidentally, Mr. Switky reports that he is enjoying himself immensely.

Wanted

Job lot of disc machines, disc records, motors, tone-arms, sound boxes, etc. Send complete description in first letter. Address "Dealer," care of The Talking Machine World, 220 So. State St., Chicago, Ill.

Simplest and Most Accurate.

Net weight only 1½ oz.

Standard Automatic Stop

Nickel . . . \$2.00

Gold . . . 3.00

Send 25 cents stamps for free sample

Order through your jobber.

Liberal Discounts.

Standard Gramophone Appliance Co.

173 Lafayette St., New York



We Have Loads of Records in Stock

and

We're Short a Bunch of Records

But—if we put in your hands, Mr. Dealer, lists of certain good popular records which we have in stock—and you start pushing those records from the lists we supply you—you'll boom your record business, won't you?

See here, we have nearly a quarter million records in stock—*let's create a demand for those we have.*

Send for our new lists—stock up, circularize your customers—and reap the record profits in spite of a shortage.

THE TALKING MACHINE CO.
12 North Michigan Avenue : : : Chicago



FROM OUR CHICAGO HEADQUARTERS

CONSUMERS' BUILDING, 220 South State Street, E. P. VAN HARLINGEN, MANAGER.

(Special to The Talking Machine World.)

CHICAGO, ILL., April 11.—Conditions in the local machine trade, both wholesale and retail, show little change over last month. There still exists a very unfortunate record shortage in certain of the lines, and little relief is expected for some time yet. There is also a shortage in practically all makes of smaller machines, which works little harm, however, for more expensive types benefit correspondingly. The sale of dance records continues to be very heavy, and Lent appears to have had little effect on the tango. A fair amount of Easter records has been sold, however.

Lyon & Healy Business Keeps Up.

L. C. Wiswell, manager of the talking machine department of Lyon & Healy, reports that wholesale business in his department is very good; in fact, shows a big gain. Retail trade is also reported as keeping up in fine shape. Mr. Wiswell reports comparatively little relief from the shortage in records that has existed so long.

Lyon & Healy continue to produce some very fine advertising matter exploitive of the Victrola. One of the latest novelties to be used is a cardboard clock, two feet four inches high and nineteen inches wide. The hands are so shaded as to create the illusion that it is real. On the face of the clock is written in red letters, "Time for a Victrola." In place of the hours, photographs of twelve Victor artists are reproduced. Melba represents one o'clock, and following in order are Tetrizzini, Ruffo, McCormack, Kreisler, Lauder, Schumann-Heink, Farrar, Pryor, Victor Herbert, Evan Williams and Caruso. In reading the hours one might say, "It is almost Tetrizzini after Pryor." On the pendulum is written "Always ready," which can be taken to mean either that the Victrola is always ready or that Lyon & Healy are always ready to serve their dealers.

Another bit of advertising that is striking is in the form of a sixteen-sheet poster to be used in Chicago by Lyon & Healy and which is sold for use by Victor dealers in other cities. The poster represents a veranda at a summer resort. The young couple dancing to the music of a Victrola which is characterized as the "Ever Ready Home Orchestra," which name was given to the Victrola by R. B. Gregory.

Mr. Wiswell leaves the latter part of next week for an Eastern trip which includes a stop at Atlantic City, where he will arrange for hotel accommodations for the talking machine jobbers'

convention which will be held there July 6 and 7. Although it has not yet been settled, the Chalfonte Hotel will probably be the scene of the jobbers' activities.

Geissler on Tendencies.

Arthur D. Geissler, general manager of the Talking Machine Co., of Chicago, and also of the New York Talking Machine Co., of New York City, N. Y., is in Chicago for about a three weeks' stay. Mrs. Geissler accompanies him and they are stopping at the Blackstone.

"There is still a very marked difference in the volume of business being done by the talking machine trade as compared with any other line," remarked Mr. Geissler in a chat with The World. "The business of the two jobbing houses with which I am associated, for instance, has shown between 30 and 40 per cent. increase during the months of January, February, March and so far in April, as compared with the corresponding period of last year, and the period last year was the best in our history.

"Dealers come in here and in New York complaining of the enormous amount of business they are losing because of the shortage in Victor machines and records. When you pin them down, however, as to the amount of business they are actually doing this year as compared with last year they freely admit that it is way ahead, many saying the increase is between 40 and 50 per cent. The fact is that the great American pulse is keyed up to the point where dealers simply cannot bear to see sales going out of the front door and in their chagrin they lose sight of the really remarkable business they are doing.

"Two instances" occurred recently right here in Chicago which illustrates phases of this remarkable talking machine business which you may care to place before the readers of The World.

"A large Illinois dealer came into my office and was talking of the wonderful Victor business, how it had grown, how it was keeping up, and how difficult it was to secure stock enough at all times to take care of the demand. He said:

"I have had to turn down several trade propositions recently. I have had a number of propositions to take in pianos in exchange for Victrolas. The trouble, however, seemed to be that the people expected too much for their pianos. I did not make the trades, for I was not anxious to take back the pianos, inasmuch as I knew I could sell the Victrolas and might not be able to place the pianos so easily. Then, again, you know that we

can get all the pianos we want of most makes.

"Then take this and consider it. A Chicago dealer phoned us up and asked if we could furnish him with a piece of wood having the fume oak Victrola finish. He had an order for a piano which was to be finished to match the Victrola, which the customer had in the house. I did not treat the request as anything unusual, but simply told him that I would be glad to send him a sample of the fumed Victrola finish and suggested that he might send a finisher to the office to see just how the fumed oak Victrolas come through. This is the first request of that kind we have had, and I thought that it was not only very interesting, but probably very significant."

Harnden Leaves Wurlitzer's.

F. H. Harnden, who has been assistant to Fred A. Simon, assistant manager to the house of Wurlitzer and actively connected with the wholesale talking machine department, has resigned his position and has become interested in an extract manufacturing concern. No successor to Mr. Harnden has as yet been appointed.

Larger Machines in Demand.

Local Manager C. F. Baer, of the Columbia Co. reports that one of the most satisfactory features of the business during the last month has been the fact that the \$100, \$150 and \$200 machines are being called for in far greater numbers than ever before. Mr. Baer accounts for this in that the talking machine is being looked upon more and more favorably by people who are able to pay the higher prices. "People who were prejudiced a short time ago are now buying heavily, not only the high grade machines, but also the better class records.

Mr. Baer reports an excellent Columbia business taken generally that is decidedly better than last year. The main trouble at the present time lies in the difficulty in getting machines, which reminds one of the condition at Christmas time.

"Increased freight rates will also mean another big increase in this business," said Mr. Baer. "When one realizes the far-reaching effects of the railroads upon general business and of its countless ramifications, we can see what a wonderful further uplift general business will enjoy when the railroads proceed to improve their roads and continue the work of extension as in years past. Of course, there are many arguments against allowing the railroads to increase their rates and cries of 'watered' stocks are not without foundation. It is true,

(Continued on page 35.)

The Practical Fibre Needle Cutter—THE WADE

The WADE embodies the right principle, worked out through long experience. It is simple, durable and accurate. It trims the needle at an angle resulting in the best tone.

The WADE cutters are made of the best steel and are absolutely guaranteed.

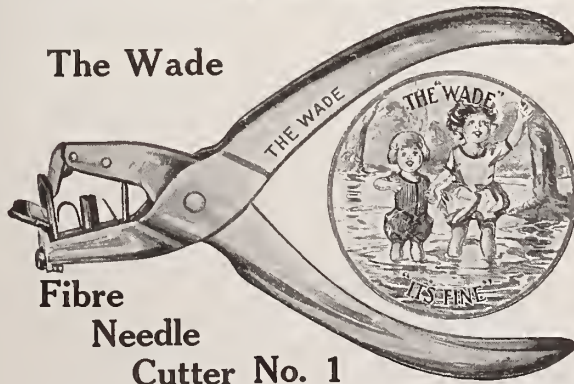

The Wade
Fibre
Needle
Cutter No. 1

The WADE is the most economical cutter. It has a self-acting stop, which prevents waste and enables one to get from 12 to 15 perfect playing points.

No. 1 is a very popular cutter which has given excellent service. No. 2 has a double action, making it especially easy to operate and affording the most powerful cut of any tool made.

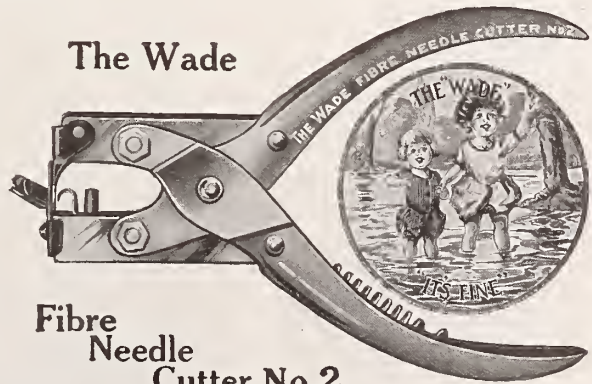

The Wade
Fibre
Needle
Cutter No. 2

RETAIL PRICES—No. 1, \$1.50; No. 2, \$2.00

Order from your regular Distributor—we sell to Jobbers only

WADE & WADE,

3807 Lake Ave.
PHONE, DOUGLAS 8108
CHICAGO, ILL.

ABSOLUTELY NEW Everlasting Dustless Record Cleaner

PATENT APPLIED FOR

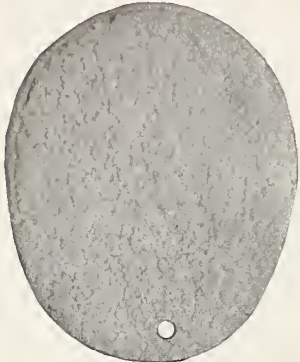

FRONT VIEW

The Everlasting Dustless Record Cleaner is made of the finest grade of carefully selected wool skin with the wool cut short.

It polishes, cleans and prolongs the life of records. Makes them look like new. It positively cannot scratch or mar records in any way, and can be cleaned with benzine, gasoline or cleaner preparation.

Retails for 15 cents. Write us to-day.

Sold to dealers in dozen lots only.

\$1.25 per dozen



BACK VIEW

Lyon & Healy

FIBRE NEEDLE CUTTER

OVER
50,000
SATISFIED
USERS

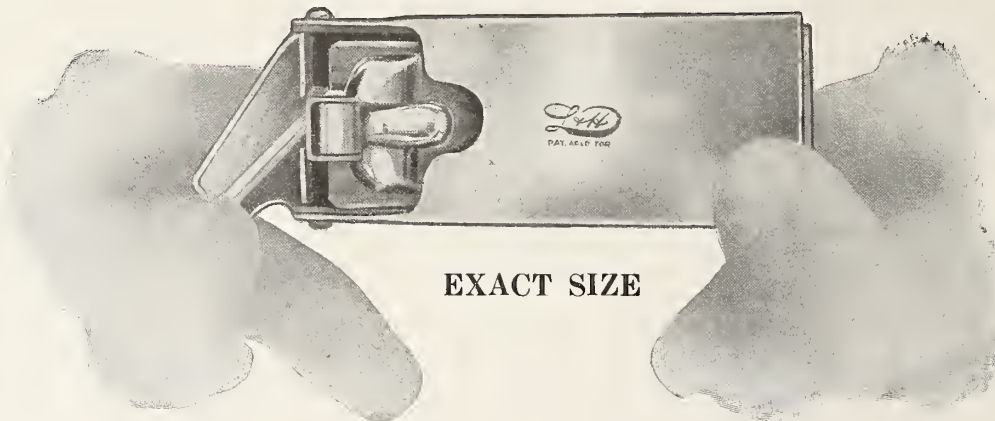

EXACT SIZE

You can order through your Jobber. He will supply you; if not, send your order to us.

The wonderful success of the Lyon & Healy Fibre Needle Cutter in the last two and a half years is due to the following facts about the cutter:

The Blades of the Lyon & Healy Fibre Needle Cutter are made of the finest grade of properly tempered tool steel. The upper blade is pivoted above and back of the cutting edge of the lower blade. It is held in place by a very high tensioned spring to insure correct leverage and a perfect point at every cutting.

The cutter is fitted with a guide that prevents the cutting away of too much of the needle, and also has a receptacle that receives all the waste. It is very simple and easy to operate, and with ordinary usage should last indefinitely without sharpening.

This cutter is invaluable to all users of the Fibre needle, as a needle may be used twelve to fifteen times where one of the cutters is in use.

Now is the time to get your order in and share in the profits.

Retail Price **\$1.50**

SEND US
YOUR
ORDER
TODAY

Lyon & Healy

CHICAGO

Largest Victor Distributors

LIBERAL
DISCOUNT
TO THE
TRADE

FROM OUR CHICAGO HEADQUARTERS—(Continued from page 33).

nevertheless, that unless the railroads get an opportunity to promote the many improvements that are contemplated, a depression that will affect almost every business will result."

Record Demand Well Balanced.

Mr. Baer sums up the record situation when he says that the entire Columbia catalog is selling well in each of the different classes. Numerous of the order numbers are receiving a bit more attention than one used to expect.

W. C. Fuhri, district manager, returned this month from a trip to Kansas City, Louisville and Indianapolis. Mr. Fuhri also reports business very good, with prospects considerably better. While Mr. Fuhri was away he noticed the large amount of dance records that the dealers were selling and also the unusually large number of "De Luxe" machines.

"Record sales continue to be very heavy," said Mr. Fuhri, "but with our immense capacity we are filling 95 per cent. of all our record orders. A big increase in the record business was anticipated by our company some time ago, and we were well prepared when the call came."

George P. Cheatle Promoted.

George P. Cheatle, well-known traveling salesman of the Talking Machine Co. and formerly in charge of the Michigan territory, has been made traveling sales manager and assistant to Roy Keith. Mr. Cheatle, whose portrait is reproduced herewith, now calls on certain dealers in the larger cities that are reached by his company and also supervises and assists the regular State travelers in the performance of their work.



Geo. P. Cheatle.

Mr. Cheatle's promotion comes after a long period of intelligent and thorough work in his old territory, and while the many friends he has made will miss him, they, of course, are gratified to learn that he has been given a wider field in which to exercise his abilities. Mr. Cheatle has been an ardent advocate of the idea of having professional dancers perform in talking machine shops, believing it to be a good medium by which the retail merchant may advertise himself and at the same time take advantage of the tremendous dance craze. While at Madison, Wis., recently Mr. Cheatle aided the "staging" of dances that were given in the warerooms of the Aton Piano Co. The dances were successful in every way.

Grocer Gives Victrola Concert.

One of the largest retail grocers of Chicago recently made arrangements with George W. Miller, a prominent Victor dealer of Ravenswood, Ill., whereby Mr. Miller gave a Victrola concert, with the assistance of H. L. Flentye, of the Talking Machine Co., in connection with a miniature exposition that was designed to advertise all of the many articles that are to be found in the modern grocery store. Between 1,000 and 2,000 invitations were issued to residents in the locality and the majority of them were used.

Mr. Miller was given ample opportunity to advertise his shop in connection with the display and gave a complete Victor program, which ranged from grand opera to the popular dance selections, made up to a great extent of the March and April lists.

Mr. Miller believes that in this manner he has acquainted many housewives in the neighborhood with the beauty of the Victrola and familiarized them with his institution. The idea is a very good one and was a success in every way.

Dictaphone Business Increases.

W. W. Parsons, local manager of the dictaphone department of the Columbia Co., reports a very substantial increase during March over the previous month and also over March of last year. Factory facilities have been strained in keeping up with the demand. Mr. Parsons reports that some recent agents for the dictaphone that have been appointed are: The B. F. Swanson Co., of Des

Moines, Ia.; A. E. Burt, of Peoria, Ill., and the Butts Typewriter Co., Omaha, Neb.

Visitors and Personals.

George Wheelock, of South Bend, Ind., was a recent talking machine dealer visiting the Great Central Market.

L. Keen Cameron, manager of the retail talking machine department at Wurlitzers, who is on a furlough in the Southwest, is said to be rapidly improving in health.

W. J. Becker, 801 Dempster street, Evanston, has installed a large Columbia stock and now handles both the Victor and Columbia lines.

J. B. Simoney has bought out the stock of Joseph Kral at 1217 West Eighteenth street and has added a large stock of Columbia goods.

A recent visitor from Rockford, Ill., was E. G. Ogren.

Mr. Simon, of Simon Bros., of Gary, Ind., who was in the city a short time ago, announced his removal into a fine new store. Mr. Simon arranged for a large stock of Victor goods.

Other Victor dealers who were in the city the past month are John Dahlin, St. Charles, Ill.; Ray E. Bannon, Morris, Ill., and Anton Molle, Antigo, Wis.

C. W. Copp, of South Bend, Ind.; L. Lambeck, Beaver Dam, Wis.; G. E. Lester, Hoopston, Ill., and W. S. Vowels, Vincennes, Ind., were also recent visiting dealers.

James Clark, buyer for the James Black Dry Goods Co., Waterloo, Ia., was in the city replenishing the company's much depleted Victor stock.

Mr. McLogan, of McLogan & Pierce, Calumet, Mich., was in the city some time ago and reported that despite the copper strike business was exceedingly good in that section. Mr. McLogan said that in one day he sold eight large machines. While here Mr. McLogan placed a very large order for the coming season.

Other visitors from out of town included Mr. Hanners, of the Hanners Organ Co., of Hanners, Ill., and Messrs. McConnell and Hoy, from Woodstock, Ill.

Mr. Solomon, buyer for the talking machine department at Rothschild's, has just returned from Europe.

James Lyons, who carries the Edison, Victor and Columbia lines, has built five soundproof booths that are models of their kind.

Mr. Becker, manager of the Hoefler Manufacturing Co., of Milwaukee, Wis., was a recent visitor to the Talking Machine Co.'s offices. Mr. Becker reported that business in Milwaukee was very good, but he, like dealers in other parts of the country, was experiencing a shortage on a majority of the records that his customers were asking for.

Miss Katharine Jones is the latest addition to the forces of the talking machine department of the W. W. Kimball Co. Miss Jones is an adept at the new dances and on many occasions uses her knowledge of the terpsichorean art to advantage in dealing with calls for dance records.

Working Out New Sales Ideas.

Despite the tremendous call for records that the Talking Machine Co. has been receiving the past month and the vast amount of work in supplying the demand, Sales Manager Roy Keith has found time to carry on much instructive work and the formulation of many sales ideas for the company's dealers.

One of the first letters to be sent out during the past month was in relation to the list of "500 Best Selling Records," which Mr. Keith had brought up to date and which included the March list. This list of 500 has proved immensely popular with dealers all over the Middle West and with their customers. It furnishes a convenient reference whereby people of average musical taste can find practically all of the records that they should have in their libraries—at least, all that they should have at this time. The pamphlet listing musical shows in Chicago at the time the letter was mailed was also much appreciated inasmuch as the theatrical and musical ideas of the entire Middle West are well typified by the taste of the average Chicagoan.

NEW COMPANY TO MAKE RECORDS

Is Being Organized in Chicago and Incorporation Papers Will Be Filed in Ninety Days.

(Special to The Talking Machine World.)

CHICAGO, ILL., April 11.—Information was received by The World to-day to the effect that the "National Talking Machine Record Co." is being organized here for the manufacture of records, and that within about ninety days incorporation papers will have been filed, officers elected and the entire organization perfected.

It is said that the new company will manufacture both lateral cut and "hill and dale" disc records and that a large space is already under consideration for the manufacturing plant.

A number of Eastern and Western business men are interested in the venture, including several theatrical men. The latter plan, in making the regular theatrical contracts, to include a provision for the making of talking machine records by the different artists booked by them.

HEAR THOSE WEDDING BELLS.

Don C. Preston and Miss Edna Fletcher Married—Will Reside in Milwaukee.

(Special to The Talking Machine World.)

CHICAGO, ILL., April 10.—Two days more and Don C. Preston will hear Victor record No. 31,227



Don C. Preston.

played under entirely different circumstances than ever before. Likewise every one of the Easter lists will probably be put on 'cause it's a great big day for Don. Easter Sunday will find him in Des Moines, Ia., all ready for his wedding to Miss Edna Fletcher, of Winterset, Ia.

After "Lohengrin" Mr. and Mrs. Preston will leave for

Milwaukee, where they will make their home. Mrs. Preston has represented the Talking Machine Co. in Wisconsin and Minnesota for some time and is well known and well liked by the Victor dealers in that territory.

The popularity of the Style IX and X Victors in the general trade was well demonstrated by the remarkable response the Talking Machine Co. received, following the announcement of these styles as produced in fumed oak. So remarkable has been the call that many dealers are insuring a supply for the fall and winter trade.

Another of the Talking Machine Co.'s sales ideas has been in the form of a strong letter designed to be sent out previous to Easter week and used in connection with a list of records of hymns and sacred music by many famous singers, choirs, etc.

"The shortage in the record supply is still felt," said Mr. Keith, "although the factory's output has been tremendously increased. At least double the records are being sold at the present time as at the same time last year. The shortage is to be expected. We have built a number of additional racks in our record rooms and by offering a selected list of records that are comparatively easy to get, we are managing to keep our customers fairly well satisfied."

Dealer Bitten by Mad Dog.

H. S. Chesrown, Columbia dealer from Mansfield, Ia., has been in the city for about three weeks receiving treatment at the Pasteur Institute in Chicago. Mr. Chesrown was attacked by a mad dog in his home city and was severely lacerated about the hands in defending himself. He was obliged to bring the head of the animal to this city for examination by the officials of the institute. Mr. Chesrown reports a good business in the Columbia line, with especially heavy sales of grand opera records and popular numbers.

FROM OUR CHICAGO HEADQUARTERS—(Continued from page 34).

THE "W. & W." FIBRE NEEDLE CUTTER.

Details of the Perfection of Its Manufacture That Will Enlighten the Trade.

(Special to The Talking Machine World.)

CHICAGO, ILL., April 10.—It should prove a subject of interest not only to talking machine dealers, but also to everyone who is the owner of one, to know something about the manufacture of the Wade fibre needle cutter.



S. O. Wade.

A very large proportion of those who use fibre needles are acquainted with the Wade cutter.

The accompanying illustration shows a corner of the Wade & Wade factory, where a very interesting

part of the manufacturing process occurs. In this room the delicate adjustments of the blades and the guides take place. As the cutters are received from the casting rooms after having first been well polished, they are prepared for the attachment of uprights and guide holders by first having the necessary holes punched in them.

The blades are made of imported Swedish steel, which comes in long strips and from which the blades are stamped out by a powerful die. They

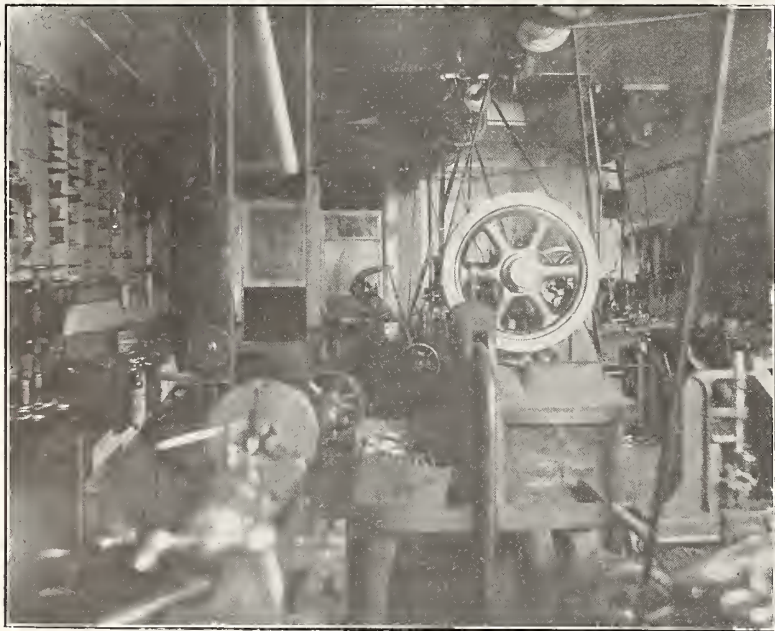

Corner in Factory of Wade & Wade, Chicago.

are then tempered in a furnace which is heated first to 1,400 degrees Fahrenheit. It is soon reduced to 700 degrees Fahrenheit, which is the temperature best suited to holding a fine edge. Guides and guide holders are stamped out and formed in similar fashion to the blades, but instead of being tempered they are heavily nickelized. The uprights and the blade springs used in the No. 1 cutters are stamped out of a steel of great tensile strength. Springs used in the No. 2 cutters are coiled and are the most efficient springs obtainable for the purpose.

The blades are first ground on a high powered stone that operates under water. They are then given an added finish by hand and then hand polished. After all the parts are carefully assembled and adjusted the cutter is tested forty or fifty times to make sure of a perfect point that the Wade cutter is noted for. If any flaw is found in the blade the blade is thrown away, or if by any chance there has been a variation in the punchings or if the adjustment is incorrect, the entire cutter is thrown away.

S. O. Wade, president of Wade & Wade, states that business during March was very nearly double that done in February.

F. J. BOWERS, PATHÉ FRÈRES, TELLS OF WORLD TRIP.

Visiting Old Home in the West After Agency Trip to South Africa, the Antipodes, Oriental Points and Italy—His Interesting Impressions.

(Special to The Talking Machine World.)

CHICAGO, ILL., April 11.—Probably the youngest salesman in the world who is connected with the talking machine industry is Frank J. Bowers, of Pathé Frères, who has just completed a trip around the world for Pathé Frères, returning April 7 to Chicago to visit his old home, his family and his friends.

Mr. Bowers, who is to-day twenty-two years old, began his travels before he was twenty. He has always been interested in the talking machine and the music trade in general, and so when his good friends, Gene Greene, "Emperor of Rag Time," and Charley Straight, Greene's pianist, went to England and France to teach Europe rag time, Frank went along. He thought it might be interesting, and it was.

"We arrived at London just as rag-time began to be featured in English music halls and Gene opened at the Palace Theater in London with great success," said Mr. Parsons to The World.

"To me the English seemed slow in getting the spirit of syncopated music and regarded it at first as a novelty that would live but a short time. Once they got it, however, their enthusiasm never waned; and, between 'Everybody's Doing It,' 'Waiting for the Robert E. Lee,' 'Alexander's Rag Time Band,' and the coming of the tango and turkey trot dances, they soon became extremely enthusiastic over it and actually 'dropped their dignity,' as Irving Berlin has it, and were snapping their fingers and swaying as they sang, just like our own rathskeller performers. In fact, on several occasions, when great parades were held, at least half of the music of the regimental bands was American rag-time. I could hardly believe I was away from home, I heard so much of it. I liked the English for it—they seemed more like our own people, and it prevented homesickness on my part.

"While in London I had the pleasure of meeting M. Jacques Pathé, in charge of the English division of Pathé Frères, and made arrangements with him whereby I was given the position of appointing sales agents in the territory of the English division. I was then instructed to go to South Africa, and sailed for Cape Town, where I made my first calls on J. W. Jagger and Stuttaford & Co. The trip from England to South Africa was, of course, most interesting, and I was much in demand among the passengers for my Pathé recitals and my knowledge of the new American dance steps. I also arranged recitals for the crew and in turn for this they were very careful in unloading the ten machines that I carried with me, and my 200 records, so that at Port Elizabeth, where everything, including passengers, was unloaded in baskets, no machines were smashed nor wet.

"My first stop in the interior was at East London in Cape Colony, where I called on Baker, King & Co., who deal directly with the Kafirs and a large number of East Indians, who are employed there in various industries, such as mining, agriculture, etc. The Kafirs buy 'Taal' records. 'Taal' is a combination of English, French, Dutch and Kafir—a sort of 'kitchen Dutch' or what we

would call 'pidgin English.' These 'Taal' records are made up specially for this trade and many of the natives spend practically all the surplus of what they earn in acquiring a machine with a few of these records. They love music so well, and a talking machine is so prized that they will work for several months in order that they may own one of the cheapest of the machines. The owner of one is looked upon as being an aristocrat, and the owners themselves are oftentimes afraid of their own possession, believing that something is within the machines. They are afraid to attempt to open them and handle a machine most gingerly at all times.

"I was obliged to transport my machines and records from Port Elizabeth to East London on a railroad that had a two-foot gauge—almost as small as the little trains we have in our amusement parks. Four passengers sit abreast, and the two on the ends are sitting well out over the track. In spite of the fact that we ran far behind our schedule, the train crew and several of the men passengers took time during the trip to play a half hour of what I would call scrub football. From Pietermaritzburg I traveled to Durban, where I witnessed an African hurricane.

"The South African people pleased me very much. They have the spirit of the pioneer and are very enterprising. I aided in exhibiting machines at various agricultural shows and had an opportunity to get close to the South African farmer and his ideas.

"From Cape Town I sailed direct to Australia, which took twenty days, and landed at Adelaide, Australia is most like America. The people are enterprising and quick to do business. The sale of religious records there is very heavy. Rag-time records were also very popular, and I arrived there at the same time that Gene Greene did on his travels. Of course it seemed good to see him, and the tremendous hits that his songs made in the music halls boomed the sale on this class of goods. Melbourne, Sydney, Brisbane and Adelaide are all fine cities and, as our business is well established there, the main part of my work was in distributing smiles and cigars.

"New Zealand was next on my route list. I found it very dull and slow, comparatively, and I think Mark Twain was justified in asking why the cow-catcher was on the front of the train instead of the rear. Visitors in the hotels are not allowed to remain after 10 o'clock, and if this rule is violated, the visitor, the visitor, and the hotel keeper are all heavily fined. I soon returned to Australia.

"I next sailed for Ceylon, where I made only a short stop. From there through the Arabian Sea to Port Said, and from Port Said through the Red Sea and through the Suez Canal. It took us a day and a night to pass through this great water way. While passing through it, we were visited by a day and a night of cold weather that broke all records, and many of the superstitious Arabians were utterly frightened at what seemed to be a refusal of the sun to shine.

"My next stop was at Naples. Here, and in fact through all Italy, there is a wonderful market for talking machines. Next I went to Marseilles, France, and then to Gibraltar, and at last to England. After arriving at London I went to France and spent two months in our factory at Chatou, which is near Paris. After a few minor trips I then prepared for my return home; and, believe me, I was glad when the 'Mauretania' pushed her way into New York harbor.

"I will be here two or three weeks to visit my family and my friends; and, after making a four months' trip through Canada, will return to London. From there my future is yet undetermined and probably I will be sent to Shanghai, China, to manage the branch there, and I will have an opportunity to study the Japanese and Chinese trade in our great industry."

QUAKER CITY TRADE WELL PLEASED WITH CONDITIONS.

Majority of Dealers Declare That March Was an Excellent Month for Business—Gimbel Bros. Buys Balance of Keen-O-Phones from Pooley Furniture Co.—Meeting of Retail Dealers' Talking Machine Association—What the Dealers and Jobbers Are Doing.

(Special to The Talking Machine World.)

PHILADELPHIA, PA., April 6.—The talking machine business in Philadelphia is forging nobly ahead, and there has never been as much activity and as much excitement as exists at the present time. The Victor dealers are all highly elated, for they have just emerged from the biggest month of the year thus far, in spite of the shortness of goods and records that are mostly in demand. The Edison has made a big stride forward during the month. The entire line of Edison phonographs has been installed in the Cunningham Piano Co.'s ware-rooms, N. Stetson & Co., Snellenburg & Co. and Ramsdell & Sons, as well as many other less important places, and in the course of a week there will be a large Edison establishment on the southwest corner of Eleventh and Walnut streets, which is now being fitted for that purpose. The Edison will be conducted there by Herbert F. Blake, and he will have fine warerooms, as well as a fine location.

The final wind up of the Keen-O-Phone Co. is now taking place through a sale of the remaining machines at Gimbel Bros. stores in this city and New York. The Keen-O-Phone Co. still has the warerooms on Broad street, but there is practically no stock with the exception of a few cheap machines which it is offering at very small figures.

When the Keen-O-Phone Co. ceased to exist the Pooley Cabinet Co. had upward of four thousand cabinets on hand, and the men who have the Keen-O-Phone Co.'s affairs in charge arranged that that company should produce sufficient machines for these cabinets in order that the Pooley Co. could come out of the deal. This was done and then the Gimbel Bros. and the Pooley Co. entered into an arrangement for the disposition of these machines at the Gimbel stores in New York and this city.

They were placed on sale there on Monday of last week. Gimbel Bros. allotted a considerable amount of space on the first and fourth floors, where these instruments are sold. Fifteen additional salesmen were added to the force to handle the customers, and it has been the most remarkable sale of talking machines ever held in this city. Every machine was marked at half the former selling price and some of them even less. In demonstrating the machines Edison and Columbia records have been used, but they have been cautioned by the Victor people against using Victor records and they are observing the caution. It is said that the Rex Co., which has taken over the record end of the Keen-O-Phone Co., will go extensively into the manufacture of records and will make a small machine which will be presented to a purchaser under an agreement to take so many records and continue to take them at specified times.

The Cunningham Co. has been dissatisfied with the arrangement of its warerooms and has removed its Edison disc talking machine hearing rooms to the rear of the store. A good business is being done, the only complaint being that it is

unable to get machines of a certain type fast enough.

N. Stetson & Co. has erected two large booths in the rear of its store and in mahogany to conform with the other finishings of the room. The selling is being handled by the old force, but it is expected that the new department will be placed in the hands of an experienced man.

The Girard Phonograph Co. at Tenth and Berks streets is the distributor of the Edison disc machine in this city, with Manager Cope, of the Snellenburg talking machine department, in charge. The machines are shipped to that point and from there are distributed to the Philadelphia dealers. The Girard Co. is also doing good missionary work in introducing the machine among out-of-town dealers.

The Wanamaker talking machine department is going to be considerably changed in the very near future. It will make one big display room and concert room out of the Louis XV. room, and will build new hearing rooms adjoining—twenty-six in all. At the present time it has eleven. It will rearrange the entire department. It has also rearranged its system and will follow up its sales and prospects closer than ever before. It will also handle more extensively in the future all kinds of talking machine supplies. Its stock will be very nicely displayed when the new arrangements go into effect.

C. J. Heppe & Sons had a satisfactory March in spite of the fact that they have been quite short on certain styles. Conditions are easing up a little bit. Among the recent out-of-town visitors at the Heppe store were J. Harry Halt, of Mt. Holly; Charles McLaughlin, of the Stoll Blank Book & Stationery Co., of Trenton, N. J.; S. C. Evans, of Milford, Del., and Samuel Stephens, of Norristown, Pa., all of whom report a fine March business.

Manager Eckhart is highly elated over the month's business done by the Pennsylvania Talking Machine Co. March was the largest month it has ever had, with the exception of last December. He says that he has not pushed his goods by advertising nearly as strong as last March, and yet his sales have been more than 50 per cent. greater. During the month quite a number of big accounts were opened, among which were the Kline-Eppihimer Co., of Reading, Pa., and the Regal Umbrella Co., of York, Pa., both firms having opened complete Columbia departments fully equipped in every way. Mr. Eckhart visited both places and helped plan the departments and was present to help start them off.

The Pennsylvania Talking Machine Co. has also had good success with the dictaphone. Among some of the firms supplied in March were the Atlas Power Co., the Armour Co. and a number of smaller concerns.

There will be a meeting of the Retail Dealers' Talking Machine Association at Estey Hall on

Wednesday evening, April 8, at which business of importance will be taken up, including shortage of records and what has been accomplished in the matter of stated charges on lease sales. All the new Edison dealers in Philadelphia have been invited to connect themselves with the organization.

H. A. Weymann & Sons note that their business in Victor talking machines for January, February and March was one-third greater than the corresponding three months of last year. Among the recent visitors at the Weymann store were C. H. Lichty, of Reading, Pa., and Charles H. Godfrey, of Atlantic City, N. J.—two active dealers. Mr. Godfrey intends to devote, in the very near future, considerably more space to the Victor line. Both of these gentlemen have been for many years active patrons of H. A. Weymann & Sons.

Louis Buehn notes that business for March has shown a very decided improvement, due partially to better shipments from the Victor factory. He had an increase over last year of over 35 per cent., which he considers is going some. His Edison dictating machine business for March has also been very satisfactory, and he sold quite a number of machines to the Witney-Kemmerer Co., the Frontier Press, and a very large order was placed by the Atlas Powder Co. in Wilmington, and it will also very shortly install a number of machines with the Du Pont Powder Co. The Business Show, which has just been concluded here and in which Mr. Buehn had an exhibit, was very satisfactory in its results. It had a great number of visitors and developed a number of very excellent prospects. Mr. Buehn is quite sure the results will fully warrant the expenditure in going into this show.

NEW HOME FOR GRAVES MUSIC CO.

Prominent Music House of Spokane, Wash., Now Settled in New Four-Story Building—Handsomely Decorated and Well Arranged.

(Special to The Talking Machine World.)

SPokane, WASH., April 7.—One of the finest music stores in the Pacific Northwest is the new home of the Graves Music Co. at 149-151 Fourth street, and to which the company moved this week from its old quarters at 111 Fourth street. The arrangement of the new store is according to the ideas of Fred W. Graves, president and manager of the company, and is up to date in every particular.

The building contains four floors and basement, with a mezzanine balcony running around the ware-room floor. On the second floor is a large recital hall, on the third floor separate parlors for the player-pianos, as well as the repair department, and on the top floor the musical merchandise department with all the instruments displayed in handsome new cases. The front of the main floor is devoted to the main warerooms and reception hall and the back is given over to the talking machine department and its seven soundproof testing booths, where both Victor and Edison machines are handled.

The main wareroom is floored with fancy inlaid marble, with the woodwork in mahogany finish. On the second floor the large showroom and the recital hall are finished in Circassian walnut and the decorations throughout are most elaborate.

The Graves Music Co., which was established in this city eighteen years ago with limited capital, now operates large stores both here and in Portland.

VISITING NEW YORK.

Russell Hunting, well known in the talking machine industry in London, England, arrived in New York last week, it being his first visit to this country in sixteen years. Mr. Hunting has many friends here who will be pleased to greet him while in this country.

If you feel that you must go about looking for trouble, carry a chip on each shoulder. It helps keep your balance when someone makes a football of your head.

The folks who do the least usually complain because other folks don't do more.

Edison DISC Phonograph Dealers

THE "Perfection" Attachment is built to play lateral cut records on the Edison Disc Phonograph. The ball bearing hanger joint gives it a free and flexible motion when traveling across the record; also it can be used with or without the feed rake. If you haven't seen or had this attachment, send us an order. You will surely buy more, as it is one of the best accessories ever placed on the market in the history of the phonograph business. It will surely increase your machine sales, as it gives perfect satisfaction to the retail purchaser. Dealers' price, \$2.50 net for all three finishes, gold, oxidized bronze and nickel.

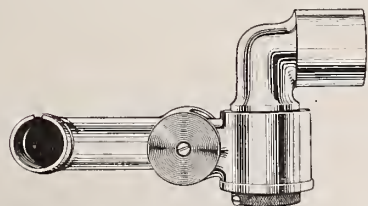
**NEW ENGLAND TALKING MACHINE CO.**

132 Boylston Street

BOSTON, MASS.



**Columbia profits begin, then they go on.
They never end. There are always
new artists, new records, new sales.**



(Write for "Music Money," a book "full of meat" for those dealers interested in quick and frequent turnover of capital.)

**Columbia Graphophone Company
Woolworth Building, New York**

REMINISCENCES OF EARLY TALKING MACHINE DAYS.

John H. Bieling, One of the Best Known Recording Artists in the Victor Library Prior to Becoming Connected with the Sales End of the Business Takes The World Representative Back to Early Days in Trade History and Relates Interesting Experiences.

"It certainly is pleasing and gratifying to see the marvelous development of the talking machine of to-day as compared to the small and primitive beginning of the work as I knew it twenty-two years ago," said John H. Bieling, of the sales staff of the New York Talking Machine Co., 81 Chambers street, New York, the prominent Victor distributor.

Mr. Bieling, who as one of the best known recording artists in the Victor library prior to becoming connected with the sales end of the business, is well qualified to comment on the growth of the talking machine business, and his reminiscences which he gave the representative of The World last week make unusually interesting reading, telling as they do of the real developments of recording art.

As told by himself, Mr. Bieling's reminiscences follow:

Some twenty-two years ago I belonged down in the old Fourteenth Ward—born and raised there; around Spring street and the Bowery. Four of us fellows used to "barber shop" on a Saturday night and Sunday, and by constant practice our voices blended in great shape in the real thing—good, old fashioned melodies and sentimental ballads. The quartet at that time was George J. Gaskin, Joe Riley, Walter Snow and myself. We called it the Manhasset Quartet.

In 1892 we had been working together about a year, when one day Gaskin told us about a man named Emerson who was manager of a concern over in Newark, N. J., called the United States Phono Co., who wanted a good quartet to make some records for him. All of us fellows worked in the day time and did our quartet work evenings. I was making stained glass windows at the time and never thought of making a regular profession of singing. Gaskin had to do some tall talking to persuade us to go over to Newark and work till all hours making these records. I assure you we were a pretty nervous quartet. The first time we went there we knew nothing of what was expected of us, but we took a chance.

Over the ferry, the train brought us into Newark and Gaskin steered us into a loft over some meat packing house about 50 by 100 and 20 feet, littered with machine boxes and barrels in every state of shipping and handling piled up everywhere. We at last got ready to make our first record and I assure you a funny sensation came over all of us. They had about nine horns all grouped together, each one leading to a separate machine connected with a piece of rubber hose. The operator then put the soft wax cylinders on the machines and let the recorder down and then said "All right, go ahead." I assure you I almost forgot to sing when I heard the sizzling noise coming out of the horns. However, we got through with that round fairly well, considering our nervous state, and after that we began to make some records and they sounded pretty good. Well, that was the first time I got real money for singing and I felt like a millionaire

going home that night. We worked contentedly along these lines for about a year, in the meantime holding down my job at my trade during the day. All was serene.

When—crash—someone invented a dubbing machine which meant that they could make any amount of records from a master record, and we could see fewer engagements coming our way with this new scheme. It certainly gave us a shock when we discovered that this new idea meant that one "Master Record" could be used to make duplicates until the wax wore out. This is how it was done: They built a machine with



John H. Bieling.

two mandrels, one under the other; on one they would put the cylinder with the song on and on the other a blank cylinder; then start the machine and throw the sound from one to the other without the services of the quartet. It was tragic, but, like all labor-saving devices, it gave birth to a greater field of work to develop records in. Where we formerly sang the same song forty times, now we sang forty different selections, satisfying the rapidly growing market for "canned music."

By this time our success as a quartet was quite famous, and we worked for all the record making companies then doing business. About this time, say 1895, we used to go over to Philadelphia and sing about once a month for a man named Berliner, a quiet, modest little German, who had us work in his little attic workshop and register our selections on a flat matrix. The machine and disc were his own ideas and manufacture, and independent of any other model then in use, so small and insignificant was the beginning of the greatest of all mechanisms in sound reproduction.

About 1896 I decided that I would let stained glass work get along without me. I took a chance

on an "artistic career." We sang for years into the same little old wax cylinders. However, Gaskin signed an exclusive contract with the Columbia Co., consequently breaking up the Manhasset Quartet. Next you find me in a quartet the members of which were Harry McDonough, S. H. Dudley, William F. Hooley and myself.

In 1898 C. G. Child, whom I had met through singing for Mr. Berliner, got us interested in a new company being formed, called the Victor Talking Machine Co. Eldredge R. Johnson was its founder, and, looking back over the years, in all seriousness I can say he is the one man responsible for the present marvelous development of the Victor talking machine of to-day. His "vision" and imagination has made possible the universal appeal of the talking machine and disc music as rated to-day.

Mr. Child suggested that the quartet contract to sing exclusively for the Victor Talking Machine Co. This is where the "Hayden Quartet" swung into line, and along with Caruso and the other stars, behold us for many years, about fifteen to be exact, singing harmoniously together in every sense of the word for the exclusive use of the Victor Talking Machine Co.

We went to London in 1902 and showed the British how to make "real records." For two months we had a large time as American representative singers. The longer I worked for the Victor Co. the more I became interested in the machine itself.

It was like getting religion! You want everyone else to get the same experience, and so make yourself the village pest. I talked machines into the homes of all my neighbors, friends, even the man I was paying off the mortgage to. By degrees the selling, or rather distributing, end of the business got hold of my imagination. Having sung for the public for twenty odd years, I wanted to make it my business to see that they all heard what I had sung. To do that they had to buy a Victor talking machine, and the managers of the company seemed to realize that my enthusiasm might be used in a very practical fashion. So Mr. Child suggested to A. D. Geissler, vice-president of the New York Talking Machine Co., that I be put to work and help tell the folks about the Hayden Quartet and the only original disc machine. I am now combining business and pleasure every day of my life by convincing all that I meet that it is the only machine to have whereby you get the exact reproduction as originally made.

Talking machine disc records composed of vulcanized India rubber were held recently by the Board of United States General Appraisers to be properly dutiable under the Tariff act of 1909 at 45 per cent. ad valorem, as parts of talking machines. The steel points used in talking machines to reproduce sound were assessed at the same rate as the discs.

Owing to the famine in Victor records at the present time, the Victor Co. announced to its trade last week that its commercial committee had decided to postpone the exchange cut-out of records until July or August, by which time the company will be in a better position to take care of it.

MISS WILSON'S COLUMBIA RECORDS.

Miss Margaret Woodrow Wilson, Eldest Daughter of President Wilson, Who Is a Singer of Unusual Attainments, Has Made Records for the Columbia Record Library Which Will Be Announced in June.

The Columbia Graphophone Co. closed one of the most important deals announced in some time when it completed arrangements last week whereby Miss Margaret Woodrow Wilson, eldest daughter of the President of the United States, will record exclusively for the Columbia record library. Miss Wilson has already visited the Columbia laboratories for recording purposes, and her first records, which will be announced in June, are said to be unusually successful, and certain to meet with a ready sale throughout the country.

That Miss Wilson is a singer of unusual attainment has long been known to her own circle of acquaintances, as her voice is naturally an organ of singularly beautiful tone. It has been developed under the direction of the world's leading teachers and this training has made Miss Wilson's voice of exceptional charm and merit.

The Columbia Co. discovered this for itself a little over two months ago, when it received instructions from Miss Wilson to make a limited number of records of her voice for private distribution among her friends. The records were made and the very first samples submitted from the factory were such a revelation that the company immediately started negotiations to the end that it might secure further records for the Columbia library. Miss Wilson was amenable to the proposal and the result is the present successful series of ballad recordings to be placed on sale in two months.

In the accompanying photograph by Edmonston, Washington, D. C., Miss Wilson is shown listening to one of her own records, "The Low-Backed Car," through the medium of the Columbia "Grand," which is one of Miss Wilson's most favored entertainers when in the privacy of her own home.

Miss Wilson's opinion of Columbia records is



Miss Margaret Woodrow Wilson Listening to Her Own Records.

well evidenced by the following enthusiastic note written the company under date of March 12 from the White House:

"The making of records of my voice in your laboratory has been a unique experience for me and it will be long before I forget the wonder and

fascination of your process. I consider the Columbia records to be on the whole the most beautiful I have heard. They are especially remarkable for their clarity of diction and tone. My own records I must frankly say have delighted me."

"MARGARET WOODROW WILSON."

CONTAINS IMPORTANT INFORMATION.

Victor dealers received this week a valuable instruction book on the repairing of Victor motors and the Exhibition sound box. This book contains twelve pages of detailed information relative to these important parts, mentioning among other

things lubrication, adjustment, how to take down the motor, examination of parts, how to replace spring, reassembling, etc. Splendid illustrations of each repair process accompany the various repair hints.

FIBRE NEEDLE "MASTERPHONE"

Is Appreciated by Record Users, Judging from Increasing Fame—Its Merits Apparent.

"We are receiving orders for the new fibre needle 'Masterphone' from all parts of the country," said an officer of the Masterphone Corporation, 187 Broadway, New York. "Although this new model has only been on the market two months, it is already proving a strong rival to the steel needle 'Masterphone' from a sales standpoint. All our dealers are well pleased with the service the 'Masterphone' is rendering, as they state that it increases the clarity of the records, improves the detailed enunciation and adds to the life of the record. Its extreme simplicity is also an important feature in its favor, as the 'Masterphone' requires no screws or nails for adjustment nor does it mutilate the machine or sound box in any way."

LYLE-ARNAULT.

The marriage of Miss Gertrude Lyle, daughter of George W. Lyle, general manager of the Columbia Graphophone Co., to Richard Arnault was celebrated Wednesday evening at the Second Reformed Church, Hackensack, N. J. The wedding was one of the events of the society season, the officers of the Columbia Co. and their families being among the prominent invited guests. Mr. and Mrs. Arnault are at present away on a three weeks' honeymoon, and upon their return will reside in Bridgeport, Conn. Mr. Arnault is connected with the Columbia factories in that city, occupying an important technical post.

CONTRACTS FOR SCHOOL OUTFITS.

The educational department of the Columbia Graphophone Co. was advised this week that it had been awarded a contract for seven school outfits, including seven horn machines and seven Mobiles, with a large supply of records, for the public schools of Springfield, Mass.

Many a man mudds himself trying to splash his competitor.

The TRITON Phonograph

Retails at \$10

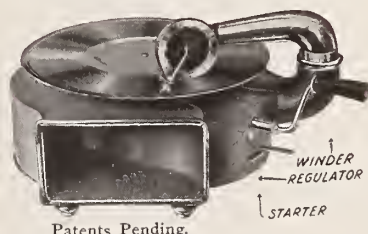

At last a real talking machine at a price within reach of all. This perfect machine is the result of years of experience and experiment in the manufacture of talking machines. It is as perfect in the reproduction of records as any high-priced machine. It plays any size of popular disc Needle Records made for other talking machines.

Every Machine Guaranteed for One Year

Sample machine sent for \$10. To secure sample you must enclose check or P. O. order; money refunded if machine is not satisfactory.

Write for quantity prices.

Town, County and State Agency Given to Live Wires.

TRITON PHONOGRAPH CO., 41 Union Square, NEW YORK, N. Y.

LIVELY TIMES REPORTED IN THE ST. LOUIS TRADE.

Shortage of Certain Styles of Machines and Records the Only Cloud—New Wholesale Store for Aeolian Co. Opened—Numerous Recitals Being Given—Columbia Co. to Remodel Quarters—Piano Dealers Succeed with Talking Machines—New Dealers.

(Special to The Talking Machine World.)

St. Louis, Mo., April 7.—March did not make the entirely creditable showing in the St. Louis talking machine business that did the previous two months of this year. The fault, however, is not with the dealers, nor the trade, but at the supply point for goods. There has been a marked shortage in certain Edison and Victor goods, and a good many of the dealers have been handicapped in meeting demands made upon them.

The trade is here, and only the goods are needed to boost the trade at any time. Dealers are placing small machines in homes temporarily, to fill the want of music, until the style of machine the purchaser wants can be obtained. Whenever the supply is equal to the demand, there will be a rush of trade in these stores.

Two downtown piano stores now are offering comparison of the three makes of machines for prospective customers, and this is proving a lure to persons who are of even mind after reading the advertisements of the three chief companies. It is peculiar, the salesmen say, how the choice falls first one way and then another under exactly the same circumstances and with the same records, and yet each customer leaves the store firmly convinced that he has made the wisest choice.

April opened with the dance records still in sharp demand, despite the handicap of Lent. The penitential season, however, has not proved much of a drawback, and a good many persons who dropped public or formal invitation dances during the forty days of mortification did not cut out the home dances, and this increased demand offset any lessened sale of those who gave up all dancing for the period.

All of the downtown houses were preparing for the after-opera demand for records of the several operas to be sung here during the month during the brief grand opera season.

Harry Levy, talking machine manager at Aeolian Hall, was busy the first of the month opening his new wholesale store on the sixth floor of the Furniture Manufacturers' Building at Fourteenth and Locust streets, where ample space has been taken for an excellent display of talking machines for the wholesale trade and for the keeping of the entire stock of machines and records in compact form. The Pine street warerooms that have served this department will be given up.

The old quarters never were entirely satisfactory, because of the crowded condition of the record warerooms and the lack of packing space for machine use. It never has been so that all of the machines carried in stock could be kept there, and another wareroom three blocks away was kept for storage purposes. The office quarters, too, were not ample for the demands, as only a balcony was available for this use, and this was not always a pleasant place to work, especially on hot days, when breezes were hard to locate. The greatest drawback to the new quarters is the distance from most of the downtown talking machine retail stores, but this will be overcome by messenger service.

The department stores have been making good use of the talking machines during the past few weeks in educating the public to the features of the operas to be sung here this month in the short grand opera season and, incidentally, planting in the minds of the people that after they hear these operas they can obtain the chief parts by investing a few dollars in records and always have direct souvenirs of the evening's enjoyment. At the Vandervoort Salon a member of the symphony orchestra was engaged to lecture on the operas and to illustrate his talks with talking machine rendition of the operas. In the Famous & Barr store special numbers were given, and at the Grand-Leader there always was opera music before the visitors.

The F. G. Smith Piano Co. gave a pretentious recital last month in Bradbury Hall to illustrate the musical points of the Columbia, which is handled exclusively by that firm.

Preparations are under way by local dealers to catch the open-air trade that comes with the motor boat and automobile coming season. These dealers have educated a part of the public to believe that an outing outfit is not complete unless it contains a talking machine with a bundle of records. Sales Manager Duffy, of the Columbia, who has enjoyed a considerable trade of this sort, was early planting the seeds from which he expected to reap a harvest later.

Mr. Duffy has discovered an office benefit from the dance craze. He says that the office force used to work by grand opera time, but since the tango records have become about the only kinds that are being demonstrated in the display rooms everybody

is moving, both at desks and on the floor, to the time of the new dances, which is about the most rapid of anything so far as display. "So, you see, we close sales and get the reports made up in less time than previously," he said.

The Columbia Co. has continued to enjoy an excellent trade on the dance records, the supply of which has been ample for all demands. Also this company has had a full supply of small machines that have come into new popularity with the dance vogue, as a good many persons who have the better class of machines buy cheaper ones for garage and barn dances, and keep them handy with a supply of the dance records for quick service in any room where there is space to dance, leaving the regular machine undisturbed in the music room or wherever it is kept.

This company is getting ready for the alterations that are to be made to the warerooms, following the signing of a new lease for a long term. The plans are complete and Manager Reid promises a surprise when his store is made over, both in convenience of the working force and for customers. In looking to the future he is preparing to handle greatly increased wholesale and retail trade with less trouble than the present traffic causes. Also he is planning for the beauty of the warerooms.

C. R. Salmon, the Columbia traveler in Arkansas, Kentucky, Tennessee and southern Missouri, was at the store a few days the first of the month and reports excellent business in these States. "The smaller town merchants are beginning to appreciate the talking machine as an easy money and satisfactory side line," he said. "Mostly they like to handle our Favorite machine and find that it suits the purses of their customers. You would be surprised if I would show you the business handled from some stores and then go down and look at their surroundings. In most of my territory the country is developing and the small towns do not make an adequate showing for their wealth, and the country around has not yet taken on the settled air. Because of the undeveloped state of society and the lack of acquaintance the people like home amusements and they buy talking machines.

"The company stores, too, are becoming good customers for talking machines. They send a good many of them into the coal mining towns and lumber camps. These orders are chiefly for small machines, but they order them in bunches and they are great consumers of popular records. Altogether this country is coming rapidly, for many persons who are buying cheap machines to-day are coming into the market again pretty soon for better machines."

The Columbia Co. recently placed a stock of machines with Childs & Anderson at Granite City, Ill., a suburb, and these men are creating a sensation in their merchandising community by their up-to-date window display and other aggressive methods of getting business. They like the trade and have decided to make the best of it in their thriving, highly paid, industrial community.

The Field-Lippman Piano Stores, the Thiebes Piano Co., the Concordia Music House, all of which are prominent firms in Piano Row, are new retail customers signed by the Columbia Co. recently. The Field-Lippman and Thiebes firms also handle Victor and Edison disc lines, and will place all three lines on display in their talking machine warerooms for comparison by prospective customers, which condition is very pleasing to Manager Reid. Other new houses on the Columbia list are Samuel Block, 3540 Olive street, city; A. E. Blackmore, Winfield, Mo.; Allen Jewelry Co., Roodhouse, Ill.; S. G. Smith, Jr., Edwardsville, Ill.; D. C. Richards Piano Co, Hot Springs, Ark.; Phil A. Lehman, 1135 Olive street, city, and George W. Brown, Hillsboro, Ill.

Miss E. Schroeder has been added to the sales force at the Columbia warerooms. She is experienced in the talking machine line and is the first woman salesman to be employed in this store, and is making a record that will make some of the young men get busy.

General Manager Irby W. Reid is the proudest man around the Columbia store at present. He was too busy to talk long and Sales Manager Duffy explained that Mr. Reid was "doubling business at home," being the father of twin girls.

How Is Your Supply of Dance Records?

Let us help you out if the tango craze in your city is so great that you find it difficult keeping up to the record demand. Stocks of Edison Cylinder and Victor Disc Records, both Foreign and Domestic, and as complete as large orders and factory deliveries can make.

Test Buehn Service on Records

Louis Buehn Philadelphia, Penn.

At the Edison Shop, as the Silverstone music warerooms are becoming known, there is much talk of the fast growing wholesale trade. "Everything with us is going just as fast as 'factory conditions,' as Mr. Dolbeer says, will permit," said Mr. Silverstone. "We are doing our very best to keep the stocks of our customers balanced to meet the trade, but when we have no machines of a certain style and the factory has none to send us, we cannot always fill orders 100 per cent.," he added.

Mr. Silverstone has just got through adding two additional demonstration rooms to his first floor equipment, making a total of six on this floor, and now he is figuring on partitioning off a small concert hall on this floor. He is undecided whether to disturb the present arrangement or to build this room on the opposite side of the corridor. The space to be gained is the chief point. It appears to have resolved itself into a matter of matching figures and the size necessary for a satisfactory sized room into which to take customers. The idea of the first floor concert room is to accommodate fifty or fewer persons. Larger parties will be taken to the second floor, where 100 or more can be seated.

F. R. Roschle, recently with the Dyer Music House in Minneapolis, has been made manager of the wholesale department by Mr. Silverstone.

Several records were made recently at the Silverstone parlors of selections sung by a Miss Reedy to be sent to the factory for inspection. A well-known local woman, who was buying records, remarked to Mr. Silverstone that some of the operatic airs in the list were not as well sung as a friend of hers rendered them, and added that she believed that this friend's voice was peculiarly adapted to talking machine rendition. Mr. Silverstone invited her to bring her friend in. It was quickly found that she possessed a remarkably accurate voice and handled her music with great ease. Her voice so greatly impressed the Edison Shop critics that several records were made, and it was with no surprise that they learned later that the young woman had taken voice lessons from an internationally known teacher, but has strong objections to singing before an audience.

Some of the new Edison dealers are: E. H. Bess Hardware Furniture Co., Fredericktown, Mo.; Frazier La Belle Music Co., Kansas City, Mo.; Hurd's Music House, Fulton, Mo.; Homersville Mercantile Co., Homersville, Mo.; W. H. Moreland, Jr., Metropolis, Ill.; A. R. Meyer, Havana, Ill.; Charles Oldendorf, Mt. Carmel, Ill.; Lutts & Feeny, Poplar Bluff, Mo.; H. Schrieber & Son, Red Bud, Ill.; J. C. Witt, Clinton, Mo.; John N. Taylor, Moberly, Macon and Columbia, Mo.; C. E. Webber, El Dorado, Ill.; W. F. Wall & Co., Cairo, Ill.; Shellack Drug Co., Galena, Ill.; Southern Illinois Music Co., DuQuoin, Ill.; C. H. Selig, Eldorado, Ill.

A framed reproduction of Thomas A. Edison's first patent papers, issued in 1878, have been attracting much attention in the Silverstone Music Co.'s windows. The drawings have been much commented upon by those who have investigated their own machines sufficiently to know the inner construction.

Fred W. Watson, of Mt. Vernon, Ill., and J. H. Bennett, of Sullivan, Mo., were recent callers at the Edison headquarters.

E. C. Rauth, secretary of the Koerber-Brenner Music Co., Victor jobbers, reports an excellent tone to the trade and that the dance craze is reaching out into the rural highways and byways and after Easter he expects a great country demand for the new records.

"In general terms," he said, "the business is just as good as it can be. If we had more business I hardly know what we would do with it. We are opening fine new accounts without trouble and all of our retailers are putting their best efforts into the work."

Recently the Koerber-Brenner Co. has been insisting to its customers suggestions for window displays and for keeping record stocks in shape, suggestions that go to make more and easier business and increased profits through less waste. One very popular move on its part has been to supply to small dealers at cost a record rack that will keep its records out of the dust and from coming into contact with each other in a way that is likely to cause damage. "The keeping of the record stock is the hardest trial to the small dealer," said Mr. Roth, "and I have found that suggestions and conveniences for lessening this part of the work are

BALTIMORE TRADE VERY ACTIVE.

Slump in Some Lines of Business Does Not Affect Talking Machine Men—General Improvement in Sales Volumes Reported.

(Special to The Talking Machine World.)

BALTIMORE, MD., April 10.—The talking machine dealers in this city and surrounding territory certainly have their rabbit feet working overtime these days; for, while persons engaged in many other lines of business are kicking about the slowness of business, these dealers of the Victors, Columbias and Edisons continue to plug away with exceptionally fine results. There is no letup in the claims made ever since the beginning of last fall that every month shows a better volume of business than the month previous. The same thing is the case with reports coming in concerning the March business.

The slate on the wall back of the desk of Manager S. A. Dennison, of the Columbia Phonograph Co. branch, is still holding up its reputation as a barometer of good luck, for this month the statement is just as encouraging as it has been for many months past. It shows that the Columbias have had a good demand and that the records have also been very popular.

W. C. Roberts, manager of E. F. Droop & Sons Co., simply sits back at his desk and wears the smile that won't come off. He explains local conditions by saying that he will be perfectly satisfied if business continues to boom the way it has for the past several months. The firm had a splendid Victor and Edison month.

The department stores report that their talking

machine departments are among the best paying ones. Both Hochschild & Kohn and Stewart & Co. make fine reports for March.

The Kunkel Piano Co., who handle the Victor and Edison lines, has had a good month. This firm is boosting the talking machine end of the business for all it is worth, with very satisfactory results. The firm has a most elaborate Easter window display, consisting of Victor and Edison machines and records arranged most artistically, intermingled with streamers of purple and white.

The Fink Talking Machine Co. is also keeping up with the band wagon and report many good sales for March.

machine departments are among the best paying ones. Both Hochschild & Kohn and Stewart & Co. make fine reports for March.

The Kunkel Piano Co., who handle the Victor and Edison lines, has had a good month. This firm is boosting the talking machine end of the business for all it is worth, with very satisfactory results. The firm has a most elaborate Easter window display, consisting of Victor and Edison machines and records arranged most artistically, intermingled with streamers of purple and white.

The Fink Talking Machine Co. is also keeping up with the band wagon and report many good sales for March.

DEVELOPING FOREIGN TRADE.

Victor Literature That Will Stimulate Interest in This Branch of the Business.

The Victor Co. sent out to its trade recently its usual list of well-conceived publicity, including the April supplement, two hangers for this supplement, copies of the April magazine advertising and supplements of new German, Italian, Swedish, Norwegian and Polish records.

These foreign record supplements are very valuable to the Victor dealer, as this division of the talking machine business is fast assuming imposing proportions in sections of the country which never recognized the possibilities of this field until a year ago. Many Victor dealers have assigned one salesman to devote himself exclusively to the development of foreign record trade, believing that this is the logical way of increasing a profitable division of their record business.

DANCE CRAZE BOOMS RECORD SALES

J. J. Black, manager of the talking machine department of the Wiley B. Allen Co., San Francisco, says the dance craze is the most important influence for the stimulation of the record business, and he does not consider the craze at its height yet. He says business has been fully normal the past month, with \$100 and \$150 Victor Victrolas in good demand.

TRIUMPHON CO., Ltd.

ESTABLISHED 1884

**Berlin, S. W., 47/5
MANUFACTURERS**

OF ALL ACCESSORIES SUCH AS

MOTORS

10 different models, ready and complete to be fitted into cabinets. From the cheapest to the best.

40 DIFFERENT MODELS



Piccolo is a complete Talking Machine. Easily to be carried like a portmanteau. Most suitable for picnic or rover parties in summer, and easily carried to social gatherings in winter. Plays 12-inch records. Is not a toy. Weight without records only 5 kg. Measurements: 11x13 3/4 x 7 3/4 inches.

SOUND BOXES

for Gramophone or Edison Cut Records. First-class workmanship.

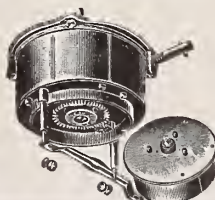

TONE ARMS

For Horn and Hornless Machines. To fit all size cabinets.

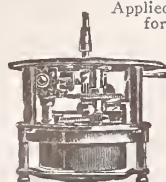

COMPLETE TALKING MACHINES

WITH AND WITHOUT HORN

Apply for Catalogues

Special Motors HYDRA SYSTEM

Single and double spring, 6 different models. Are the only existing construction which allows the exchanging of the spring and spring case without taking the motor out of the cabinet. After loosening one nut, a child is able to replace any defective spring or springbox within 20 seconds.

Patents Applied for.

TO DISCUSS ANTI-TRUST BILLS.

Retailers in All Lines of Trade Interested in Meeting to Consider New Legislation, Including the One-Price Plan of Merchandising—John G. Bremner Member of the Committee of Local Retail Merchants.

Retailers in all lines of trade are displaying much interest in a mass meeting to be held here in the near future to discuss the relation of the dealer to pending anti-trust legislation at Washington including the proposed one price to all plan of merchandising and kindred issues. The committee for promotion of the interests of retail merchants, which was organized at a meeting held last week in New York in the assembly room of the Fifth Avenue building, has not set a definite date for the demonstration, but it is supposed that the meeting will take place on April 24. Francis L. Plummer, 169 West Seventy-eighth street, New York, is secretary of the committee.

W. G. Anderson, well known in retail circles and a member of the faculty of the Brooklyn College of Pharmacy, was chosen as chairman of the committee, the other members being John G. Bremner, president Eastern Talking Machine Dealers' Association; Nicholas Ehrlich, president Independent Retail Tobacconists' Association of America; Alfred D. Woodruff, manager Food Supply Store, New York Association for Improving the Condition of the Poor; Carl E. Ackerson, representing the Photographic Dealers' Association of America; R. J. Atkinson, president Brooklyn Hardware Dealers' Association; J. M. Kohlmeier, Hardware and Supply Dealers' Association of Manhattan and Bronx Boroughs, Inc.; Caswell A. Mayo, secretary-treasurer New York Pharmaceutical Conference. Representatives of other trades will be added to the committee.

It is understood the tentative list of speakers includes well-known public men and trade authorities of national reputation. The plan of the committee is to encourage similar gatherings all over the country for the purpose of bringing retail dealers in closer touch with legislative matters that concern them vitally. It is pointed out that some

lines of trade have displayed apathy in past years, but that there is now a notable tendency of retailers everywhere to assert their influence. It is pointed out further that the retail population of the country, together with those depending on them for support, equals one-tenth of the nation's total population. The retailer's voice, according to the committee, should command a corresponding degree of attention in State and national legislature. The main purpose of the meeting therefore will be to increase respect for the dealer as an important element of society.

BETRAYING CREDIT INFORMATION.

Violations of Trust Properly Condemned by a Writer in the New York Times—Confidence Should Be Preserved If There Is to Be an Interchange of Views.

Although credit men have repeatedly emphasized the duty of preserving confidences where credit information is given or obtained, violations of this trust crop up from time to time that lead to very unpleasant results. While it is necessary for a house, which has been asked to extend a line of credit, to know how an account is checked by other concerns, it is considered an unpardonable breach of confidence to turn over such information to the prospective customer. An instance is being related in the trade at present where an investigator violated the trust imposed upon him in this manner, and it is doubtful if he or his house will receive in the future the information they desire from the parties they offended. It is the general sentiment in credit circles that a breach of this kind deserves drastic treatment.

ENLARGING "TALKER" DEPARTMENT.

The Haverty Furniture Co., Savannah, Ga., which has been a very successful Columbia dealer for several years, is enlarging its talking machine warerooms and constructing six new demonstration booths. These improved show rooms will be decorated and furnished in an attractive manner.

NEW CONCERN IN PITTSBURGH.

Liberty Talking Machine Shop Opens in Central Business District.

(Special to The Talking Machine World.)

PITTSBURGH, PA., April 7.—The Liberty Talking Machine Shop is the name of a new store opened at 819 Liberty avenue April 1. The Victor Victrolas are handled exclusively. This store is a part of the building occupied by the Greater Pittsburgh Piano Co.



J. E. Hornberger is the manager of the new store. Mr. Hornberger was formerly connected with the Pittsburgh store of McCreery & Co. as manager of the talking machine department; was also manager of the Talking Machine Shop in the Jenkins Arcade Building and, until assuming this position, was special representative of the W. F. Frederick Co. talking machine department.

REPORTS HEAVY VICTOR TRADE.

(Special to The Talking Machine World.)

SAN FRANCISCO, CAL., April 4—A. G. McCarthy, of Sherman, Clay & Co., reports a very good month's Victor business, both wholesale and retail, the books showing a substantial increase over the corresponding period of last year. The company has its new music room on the eighth floor of the building ready for use now, and a Victor Victrola forms a part of the furnishings. This room is said to be the most elaborate room of its kind in any music store in the country, and fully as nicely carried out in design and furnishings as the music room in any home in this vicinity. A better setting cannot be imagined for the demonstration of a Victor Victrola.

Victrolas and Record Stocks Short

Be just to yourself and your customers

You owe it to yourself and your customers to give us a trial at filling your orders before you lose a sale by telling them that you "haven't got it and can't get it."

We cannot truthfully boast

about the completeness of machine and record stocks; nevertheless you can get from us certain types of machines and many selections of records that are not to be gotten elsewhere. New numbers are coming in daily.

TAKE NOTHING FOR GRANTED UNTIL YOU HAVE TRIED

BENJ. SWITKY, Victor Distributor NEW YORK, N. Y.

SUPERVISING DANCE RECORDS.

Illustration of the Manner in Which G. Hepburn Wilson, Dance Expert, Insures the Accuracy of the Columbia Dance Records During the Actual Recording by Dancing Before the Orchestra to Indicate Tempo.

The accompanying photograph, taken recently in the local laboratory of the Columbia Graphophone Co., gives an excellent idea of the detailed supervision which characterizes the production of Columbia dance records. As announced in the columns of The World some time since, all Columbia records intended for dancing purposes are manufactured under the personal supervision of G. Hep-



G. Hepburn Wilson Dancing for Columbia Record Makers.

burn Wilson, M. B., one of the company's leading interpreters of the modern dance, and conducting a number of successful dancing schools in the most fashionable sections of the city. His corps of teachers are skilled in all the intricacies and finer points of the modern dances, and in the illustration herewith Mr. Wilson is shown dancing

to one of the Columbia Co.'s new dance numbers, accompanied by one of his star teachers.

"The supervision of Columbia dance records by Mr. Wilson is far more than a mere formality and a stereotyped O. K.," said a member of the Columbia recording staff. "When dance records are to be made at our laboratory, G. Hepburn Wilson brings along two dancers from his corps of instructors and when Charles Prince and his band start to play the dancers start to dance. As expert dancers, they are, of course, sensitive to every detail of rhythm and if it is not absolutely as it should be—they stop dancing. That brings the band to an abrupt halt. The fault is discussed and corrected and the record is begun all over

CONDITIONS IN THE TWIN CITIES.

Talking Machines and Records Apparently on the High Wave of Popularity in That Section of the Northwest—New Departments Making Good—L. H. Lucker Home from Visit to Edison Factories—News of Moment.

(Special to The Talking Machine World.)

MINNEAPOLIS AND ST. PAUL, MINN., April 8.—Dealers in all classes of machines for reproducing sound are on the crest of a wave of prosperity—at least they all speak in superlatives when discussing trade conditions, and as they are honest men business must be good. The department stores may have cut into their legitimate trade somewhat, but whether or not this competition has effected the business of the straight talking machine merchants the latter are not grumbling.

The piano men who have talking machine and phonograph adjuncts are very pleased for the side line is paying the expenses, and in some instances are running a neck and neck race with the piano departments for supremacy.

The Talking Machine Co., Archie Matheis manager, is finding itself in clover with business on the increase, March returns far in excess of those of March, 1913, and prospects rosy. The house is giving special recitals as a prelude to the grand opera season, and finds much interest shown therein. The aftermath unquestionably will be run on records.

The department stores, two in Minneapolis and one in St. Paul, which recently established talking machine departments, report a satisfactory volume of business from an experimental standpoint.

Columbia stores continue to do a pleasing business, both in Minneapolis and St. Paul, and also in the rural sections. The new \$100 machine seems to be the favorite, and these go about as fast as they can be obtained. Most of the soloists in the grand opera season are Columbia artists, and naturally the Columbia records will be in demand for some time, both before and after.

Laurence H. Lucker, of the Minnesota Phonograph Co., returned Saturday from a visit to the factories and headquarters of the Edison Co. He made arrangements that will expedite the filling of orders for his house. His complaints for some months have been that he was unable to obtain goods in sufficient quantities to keep pace with the demand, and that the trade suffered materially in March on this account.

"Shipments will be coming more rapidly from now on," declared Mr. Lucker. "We received a whole carload to-day, but nearly all had been ordered previously, but other shipments are coming. This is imperative in a way, as we have established a large number of Edison agencies throughout the Northwest and must have the goods, and particularly the records."

Clark & Co., well-known book sellers and office outfitters, Vicksburg, Miss., have secured the agency for the Edison disc phonographs and have opened up very attractive quarters in that city.

again. This procedure is followed until the entire record has been played absolutely right.

"A few days later a sample record is sent to the laboratory from our factory. Again Mr. Wilson is called in, and if, after listening, he is satisfied, he O. K.'s it; otherwise the record is condemned and destroyed."

in 1908. In addition to several prominent makes of pianos and player-pianos, making up a regular stock of over eighty instruments on the wareroom floors, the company also handles the Victor Victrola with marked success.

A COMPLIMENT.

Mark Hambourg, the pianist, tells in the Strand Magazine of an incident that happened to him when he was a visitor at the house of a friend. He was practising away for all he was worth when a woman friend of his hostess called and was shown into the adjoining room. The visitor listened to Mr. Hambourg's playing for a few moments, and then remarked, with a seraphic smile: "Why, Mrs. Blank, how your little girl is improving on the piano!"

THE HUMES CO. TO REMOVE.

Well-Known and Successful Concern in Columbus, Ga., to Have Handsome New Building.

(Special to The Talking Machine World.)

COLUMBUS, GA., April 7.—The Humes Music Co., at present located at 1127 Broad street, this city, will shortly occupy the new Illges Building now being completed at 1032 Broad street, and which is especially designed to meet the requirements of the business of the company. The various floors of the building are fitted up with a series of soundproof demonstration booths for pianos, player-pianos and Victrolas and an electric elevator serves to connect the floors for the convenience of customers.

The Humes Music Co. has had a most successful career in the local field since its establishment

RECORD FANS FOR SUMMER SALES

FAN COUPON

Please send us at once a sample of your Record Fan.

Name

Address

Any talking machine dealer who really wants to boost his summer business will meet with great results thru the use of our RECORD FANS. The price is so low and the goods so great that you will all want to buy before it's too late.

THE RECORD FAN AND CALENDAR CO.
118 Asylum Street - - - HARTFORD, CONN.

Vernon Castle recommends Columbia dance records. He says:



"I want to congratulate you on the excellent dance records you have recently issued; they are the best I have heard. I am using a Columbia "Grand" Grafonola and Columbia records at Castle House where they are attracting extraordinary attention. The records are played in perfect dance time and are frequently encored by our patrons."



Vernon Castle

(Write for "Music Money," a book "full of meat" for those dealers interested in quick and frequent turnover of capital.)

Columbia Graphophone Company
Woolworth Building, New York

DETROIT PIANO DEALERS TAKE ON TALKING MACHINES.

Frank J. Bayley to Handle the Edison Line and Ruediasale Co. Opens Columbia Department—Talking of Organizing Local Talking Machine Association to Check Numerous Trade Evils—Previous Attempt Failed—Dealers Finding That Service Pays.

(Special to The Talking Machine World.)

DETROIT, MICH., April 8.—Two more Detroit piano dealers have taken on talking machines this month. They are Frank J. Bayley, who is president of the Detroit Music Trades Association, and the William J. Ruediasale Piano Co., which has a large store at Gratiot and Van Dyke, in the rapidly growing East End.

Mr. Bayley is handling the Edison. He will put in the full line as soon as the jobbers can furnish him the instruments.

"I think the talking machine business is a very good business to engage in," he said. "I have seen stores that have started in a modest way grow until they are larger than many piano stores. While I do not intend to let the talking machine business curtail our piano business, I do intend to develop the talking machine end as far and as fast as it will grow."

The Ruediasale Co. has taken the Columbia, ordering several hundred dollars worth of the Grafonolas and records to start with. The store is a large and well located one, in a district well adapted to the sale of talking machines, and particularly to the sale of records. S. E. Lind, city sales manager of the Columbia branch store, always impresses upon the dealers in the outlying districts the advisability of carrying as complete a line of records as facilities will permit, because the sale of machines means a constant demand for records, and if the suburban dealer has a good stock patrons will not take the trouble to go downtown to buy.

There is a movement on foot among the Detroit talking machine houses to organize a trade association. It germinated in the agreement made last fall to charge interest on instalment sales. That agreement has brought much benefit and much profit to the dealers, and has given them an insight into what can be accomplished by concerted action.

An attempt was made about five years ago to form an association. It looked like a success for a few minutes, officers being elected and dues being paid in. Nearly every dealer in the city was represented. But when it came to the matter of rules and by-laws, the association split on the proposition of the establishment of two prices, the regular price for cash and a higher one on instalments. That was long before the interest arrangement went into effect. The latter agreement removes the necessity for a double price. And the dealers discern that there are several other matters which would make an association a valuable adjunct to the business and a benefit to all members.

For one thing, the people who manage to have talking machines, or new records, in their homes most of the time without paying a dollar, could be checkmated. Records kept by some of the dealers show that nine out of ten people who desire to have talking machines sent to their homes on

approval fail to buy. They simply considered that a good way to obtain a machine for some entertainment without expense.

Other people, who own machines, ask to have new records sent to them on approval. Some of them manage to hang onto them for a week, and then return them all as unsatisfactory. In the interim they have played them until they are tired of them. Next month they play the same trick on some other dealer. There are so many dealers in the city now that they can keep the game going indefinitely.

If there was an association such grafters could be listed with the secretary. There would be no black list, no telling by one dealer to another that So-and-So was not exactly square in his dealings and thus cause danger. The names simply could be listed with the secretary, and when a dealer wanted to be protected he could go and examine the list.

That would be of double benefit. It not only would prevent the losses incident to such operations, but, with their free supply cut off, the grafters would be compelled to buy.

A monthly banquet and an exchange of ideas and experiences also would be of much benefit to the members. The talking machine dealers of Detroit are on very friendly terms with each other, though keen competitors. They speak well of each other and of each others goods and business methods, and it seems as though such banquets could not help but be amicable and productive of still better feeling and still better success.

In every business there are some chronic "outsiders"; objectors to everything and anything that others may propose. But in such an association as the talking machine dealers have in mind the membership of all dealers would not be necessary to make it a success. It would be a sort of mutual benefit association. The only ones to lose anything if some dealers remained aloof would be the ones who remained aloof.

Business is still good. Every month shows an increase over the previous month and a bigger increase over the corresponding month of last year.

Selling service as well as the machines is becoming a policy of nearly all the dealers. They find that it pays. It means not only pleasing a customer when he buys a machine and some records, but keeping him pleased and therefore naturally keeping him as a customer. If some little thing goes wrong with a machine a man is sent out to fix it. If certain records are not satisfactory, and a good, legitimate reason is given for their not being satisfactory, the party is given his choice of new records or a return of his money. Almost any man knows when he is being treated liberally and will return there for more of the same.

Service in records consists principally in having the records the people want when they want them. The stores which carry everything get new cus-

tomers for records almost daily—people who have had machines for some time, but have not been able to get all they desired in the way of records at the places they bought the machines. Of course, having once located an unabridged stock of records, they become permanent patrons of it.

K. M. Johns, manager of the Detroit branch of the Columbia Co., has the sincere sympathy of the trade this week on the death of Mrs. Johns. He has not been at his desk for several days.

MORTIMER D. EASTON TO MARRY.

The engagement was announced on Sunday of Mortimer D. Easton, son of Edward D. Easton, president of the Columbia Graphophone Co., to Miss Marie Rankin, a prominent society belle of Goshen, N. Y. No date has been set for the wedding. On the same day the engagement of Miss Helen Easton, a daughter of President Easton, to Morris M. Munton, Trenton, N. J., was also announced.

Mortimer D. Easton has been connected with the Columbia Co. for a number of years, having achieved a pleasing success as road ambassador for the Dictaphone Department in both domestic and export territories. Mr. Easton is at present a member of the Columbia Co.'s advertising department, where he is acquiring a detailed knowledge of this important branch of the business.

Isaac Lesem, talking machine and musical merchandise dealer, Kansas City, Mo., has filed a petition in bankruptcy with liabilities of \$4,100 and assets of \$850.

The world is pretty full of men who hand out a five-cent cigar expecting a \$50 favor in return. But you don't need to give up smoking on that account.

PHONOGRAPHISCHE ZEITSCHRIFT BERLIN W. 30, GERMANY

The oldest and most up-to-date trade paper covering the talking machine line published in the German Language.

PUBLISHED WEEKLY. FOUNDED 1900

Circulates all over the world.

SPECIAL EXPORT NUMBERS appear in four different languages at regular intervals.

Subscriptions for this talking machine publication 10 Marks yearly. Sample copies sent free.

FROM OUR EUROPEAN HEADQUARTERS

2 GRESHAM BUILDING, BASINGHALL STREET E. C., LONDON, W. LIONEL STURDY, MANAGER.

Trade Generally in Very Fair Shape—Credit Situation Far from Being Satisfactory—Blamed by Many on the Flood of Cheap Records—Spring Leipzig Messe Very Successful—Some of the Exhibitors—Music Publishers Making Own Records—Copyright Societies Active in Protecting Interests of Members—Some Recent Cases—Operatic Records in Increasing Demand—Latest Instrument on the Market—Some of the Recent Record Issues—Pathe Freres Win in Hornless Machine Patent Suit—To Mark British Origin of Goods—General News of Month.

(Special to The Talking Machine World.)

LONDON, E. C., April 6.—Trade in this country continues to make a very fair showing, period considered, although as may be expected, retail sales have a tendency to decline in volume as the summer approaches. Traders, however, profess themselves well satisfied with the spring business and are optimistic regarding future prospects. This is all very well in its way, but when one considers the conditions of gramophone commerce to-day, more especially from the financial viewpoint, things do not appear so bright as collective party opinion would have us believe. Take, for instance, the position of credit. I have made special inquiry among those who can speak with authority, and almost without exception they have a deplorable tale to tell. "Credit in England," said the cashier of a large house, "is akin almost to philanthropy. At the present moment we have outstanding many thousands of pounds approximating in the neighborhood of 40 per cent. of our annual turnover. This is a very serious item in relation to profits, and as you may imagine, causes us not a little anxiety. Only a small percentage of dealers pay at thirty days; the average credit period taken is anywhere between six and nine months, and even longer if bills are obtainable."

Replying to a query, my informant assured me that the practice of passing bills for discounting was a growing evil in the gramophone trade, and it made a big inroad into profit which manufacturers could not really afford. One specialty maker with whom I conversed spoke very pessimistically of the question. He said: "I am about to finish up with dealers altogether, for they do not pay. They want nine or twelve months' credit and I cannot afford to give it, therefore I will endeavor to conduct my business direct with the public."

Several others assert that since the advent of cheap records credit conditions have become increasingly worse because these records are in themselves not profitable to handle and they have seriously reduced the sales of higher-priced discs. In this view there is unfortunately much truth, and it is frankly endorsed by more than one manufacturer of this class of record. I even heard of one large company who, more as a test than anything else, perhaps, actually offered their agents a special 10 per cent. discount above the usual terms for prompt monthly payment. It may be accepted as a significant index of conditions in this market that not five per cent. took advantage of this generous offer. A well-known fact, too, is that another very big concern has on its books debits against dealers to the extent of something like £60,000. Undoubtedly a goodly percentage of this money is safe, but conditions which allow of such enormous credit are obviously commercially unsound. What we need is a central bureau under the control of all the leading gramophone companies, where may be blacklisted the names of dealers who systematically shirk their monetary obligations. A plan along these lines would soon bring them to book or force them to suspend in favor of more responsible traders.

Spring Leipzig Messe a Big Success.

There is a good deal of sentiment attaching to a visit to the Leipzig Fair, and, from the talking

machine point of view, not a little habit. It is customary for many of the leading members of the trade to make this pilgrimage every year in the hope of finding something new, but the trade has now developed to such an extent that the chances of so doing become fewer and fewer with each recurring season.

Anything really good and new in this year of grace finds its way to London as quickly as it does to Leipzig, so that even the stay-at-home British trader generally has an equally good chance as does he who goes to Leipzig.

There is, however, this distinct advantage in going—one is enabled to see practically side by side all the novelties that there may be and thus, with the aid of the direct comparison, form a more satisfactory conclusion as to the merits or demerits of each article. All this is preliminary to stating that there was really nothing of practical interest to be seen this year, outside of course what may be termed novelties.

Lindstrom & Co., for example, were showing an exceptionally ingenious automatic machine in which every process, including the changing of the record and needle was carried out mechanically. This remarkable cabinet instrument is well called "The Miracle." It is described as automatically playing any record from a selection of ten without touching the record or sound box. There are ten records, placed in a moving platform. All that the person desirous of hearing a tune has to do is to put the indicator at the selection of his fancy, place a penny in the slot, or touch the stop or start lever, and the instrument will do the rest—that is to say, it will automatically put a needle in the sound-box, bring the record up to the turntable, play the record through, return the record to its original place after being played, and throw out the old needle. This instrument, it is said, is so wonderfully constructed that it is practically "fool-proof." A penny cannot be put in the slot until the tune is finished. "The Miracle" was very much admired by all who saw it, and I am given to understand that large orders have already been booked in Germany for this article.

The Beka Co. obviously intends to enter into serious competition with the phono-cut manufacturers, as they were showing a new record of the ordinary phono-cut type which is shortly to appear on the market.

The Beka Record Co.'s exhibits also included a new model called the "Perplex," which by means of a cleverly arranged mechanism can be adapted

into a sideboard. The Odeon people were showing an apparatus in the style of an elegant sideboard.

Attention was centered upon the Zonophone exhibit of a new kind of instrument in the form of a miniature piano which attracted much favorable comment.

The Industria Blechwaren Fabrik exhibited a new design of iron horn, very similar in shape to the well-known Music Master Wood Horn and enameled to imitate wood. Metal cabinets were another novelty exhibited by this go-ahead concern, various designs for hornless and ordinary horn models being on view.

The ingenuity of German manufacturers is strikingly exemplified in the exhibit of Messrs. F. A. Anger & Sohn, Jöhstadt Sachsen, who are exhibiting an extensive range of disc record cabinets; among the many attractive designs shown, one in particular having a roll top front with a removable record holder, attracted considerable attention.

Great interest was taken in the National Gramophone Co.'s complete exhibit of their Marathon instruments and records at 41 Peterstrasse (Clemens Humann). These fine products are more or less new to Continental traders, and to say they met with keen approval gives but a faint idea of the extraordinary interest displayed.

Other exhibits included excellent displays of gramophone parts and accessories by German, French and Swiss manufacturers, and in addition there were to be noticed representative exhibits of complete instruments, tone-arms, motors, horns, sound boxes, cabinets, needles and records, etc. The business at the Fair this year is said to have been in every way highly satisfactory. Buyers were present from all parts of the world, an especially strong contingent being present from England. A list of English visitors appeared in my last report.

Another Important Copyright Case.

In protection of their interests the members of Copyright Societies must be expending quite an amount of money of late. The case reported last month resulted in costs and fines against an infringer of certain copyright works, and now we have another case where infringement of copyright is alleged. As reported in the newspapers, summonses were taken out at the instance of Frank Mabe, an inspector of the Mechanical Copyright Licensees Co., Ltd., against William Jennings, trading as the Runwell Cycle Co., 16 Great Eastern street; Blum & Co., Ltd., Old street, and W. H. Reynolds, Ltd., 95 Great Eastern street, London. There were four summonses against each defendant for "unlawfully and knowingly offering for sale an infringing copy of a copyright work, contrary to the provisions of the Copyright Act, 1911," and the dates of the offences were given as the 5th, 6th and 7th of March. H. Houston, barrister, appeared to support the summonses. Travers Humphreys appeared for Mr. Jennings. A. Richardson defended Blum & Co. The subjects of the summonses were gramophone records of "The Gondoliers," "The Pipes of Pan," "Onward, Christian Soldiers," "The Lost Chord" and "Your Eyes Have Told Me So." In opening the case Mr. Houston said he should like to read the particular section (Section XI.) of the Act, which bore directly on the point, the wording of which ran, "If any person knowingly sells or offers for sale or hire any such copy of a copyright work, he shall be liable to a penalty not exceeding 40s. for a single offence or not exceeding £50 for any one transaction."

Mr. Biron: It does not mention gramophone records.

Travers Humphreys: There is no point raised as to that.

Frank Mabe said he was an inspector employed

(Continued on page 46.)

STROH VIOLS

VIOLIN, VIOLA, ETC.

The mellow and matured tone of these instruments, which are constructed largely of aluminum, yet possess *none* of the characteristics of the gramophone or wind instrument, is only one of its many points which are fully set out in an illustrated booklet which will be mailed free on request to the *sole makers*.



String Fiddle

GEO. EVANS & CO. 94 Albany St. London, Eng.

OR

in U. S. A. to their sole representatives

OLIVER DITSON Co.

150 Tremont Street
BOSTON

NEW YORK and PHILADELPHIA

Violin

FROM OUR LONDON HEADQUARTERS—(Continued from page 45).

by the Mechanical Copyright Licensees Co., Ltd., of 27 Regent street. In accordance with his instructions, he called at 16 Great Eastern street on March 5 and there obtained a catalog of gramophone records. He found the said catalog contained titles of various works in which copyright subsisted and in which his association had an interest. He still had that catalog in his possession. In pursuance of the offer contained in the catalog he attended at 16 Great Eastern street on the following day and purchased three gramophone records, entitled "The Gondoliers," "The Pipes of Pan" (erroneously printed on the record as "The Pipers of Pan") and "Your Eyes Have Told Me So," which were numbered 14, 35 and 43 in defendant's catalog. He examined the records and found there was no "royalty" stamp on any one of them. He produced the invoice showing the purchase.

Cross-examined by Travers Humphreys, witness said there was nothing on the records in question to show they were the subjects of copyright. On one of the records the title was printed "The Pipers of Pan."

Travers Humphreys: That is a mistake, obviously.

Continuing his replies, witness said he knew the songs in question were the subjects of copyright, because his association acted for the composers. It sometimes happened that more than one person claimed the copyright in a song. He did not think that defendant personally acted as salesman during the purchases in question.

Travers Humphreys said he had not yet heard that the songs in question were the subject of copyright.

Mr. Houston: I have two certificates of copyright here, and they are evidence under the Act of 1842. "The Pipes of Pan" has been composed since, and we have not the certificate for that. Section 6 of the Act, sub-section 3, deals with the evidence of copyright. It says that "in any action for infringement the work shall be presumed to be—"

Travers Humphreys: This is not an action.

Mr. Biron said he did not think the reference applied. He supposed there was some record kept of copyrights.

Mr. Houston said he could get certificates, but for that purpose he would have to ask for an adjournment.

Travers Humphreys: I wish him to satisfy us that these certificates are evidence. The Act of 1842 has been repealed.

After other members of the trade, including Sir Edward Elgar, had given evidence, Mr. Biron said that at present there was no evidence before him, and perhaps an adjournment would be advisable.

Defendant: I wish the case disposed of. I have an indemnity against any action, and I do not want to waste my time.

Mr. Biron: I do not think I can deal with the case at all as there is no evidence, but I shall consider this on the question of costs on the next occasion.

The further hearing was adjourned.

During the hearing of these summonses, some interesting points in regard to the scope of the copyright act were brought to light. Emphasis was placed upon the fact that the onus of putting copyright stamps on records rests with the record manufacturers, and a dealer cannot therefore be convicted of selling a record without a stamp thereon unless he does so "knowingly." Another matter mentioned by counsel and endorsed by the magistrate was the need for the registration of copyrights at, for instance, Somerset House, where a dealer or manufacturer could inspect the list of copyright works. It was further suggested that such registration should be made by application, and that a person seeking to register his copyright should attest his nationality and give satisfactory reasons why the copyright should be granted to him. And further, that the present anomalous position of the various societies selling stamps should be so prescribed that only one concern could claim the right to sell stamps. It is

said that no less than five different claims to sell stamps on one particular work have been made. For the "arrangement" of certain non-copyright works of which an edition has been printed and published, we are informed a publisher is claiming royalties from record manufacturers. Altogether this copyright act is causing our trade a lot of trouble and expense on account of its vagueness.

Demand for Operatic Records.

Signs are not wanting of a greatly increased demand in this country for operatic records among sections of the community which hitherto confined their purchases to comic songs and sentimental ballads. Three or four of the leading concerns have largely specialized this class of music in their publicity announcements during recent times, and to this in no small measure is due perhaps the increased popularity of celebrity issues. In this connection the "H. M. V." Co. occupies a leading place. Last month witnessed the inauguration of a special celebrity campaign lasting one week, during which period "H. M. V." agents all over the country made an effective window display of celebrity records. The company co-operated with large advertisements in the big London and provincial organs, and needless to say, the whole scheme proved a fine success. Many dealers, in fact, are still keeping it up, at it were, reaping the after-harvest of sales.

Coincident with the opening of this campaign, the "H. M. V." company announced the publication of a fine piece of publicity work consisting of an illustrated catalog of records by international artists. This brochure provides a wealth of biographical and otherwise interesting particulars of "H. M. V." artists, indexed and classified for easy reference. A magnificent production which is indeed deserving of a prominent place in every record enthusiasts library.

Grand Opera at Popular Prices.

Some twelve months ago the Columbia Co. announced a series of fifty records in the Columbia-Rena "Opera" catalog. They were wonderful
(Continued on page 48.)



To T.M. the King and Queen of Spain



To H.M. the King of Sweden



To H.H. the Khedive of Egypt



To H.M. the King of Italy

"His Master's Voice"

—the trade-mark that is recognised throughout the world as the

Hall-mark of Quality



To H.M. the Shah of Persia



By Appointment To H.M. Queen Alexandra

AUSTRIA: Oesterr. Gramophon-Gesellschaft, m. b. H., 8, Krugerstrasse, Vienna.
BELGIUM: Cie. Française du Gramophone, 51, Avenue de la Porte de Hal, Brussels.
DENMARK: Skandinavisk Gramophon-Aktieselskab, Frihavn, Copenhagen.
FRANCE: Cie. Française du Gramophone, 115 Boulevard Richard Lenoir, Place de la République, Paris.
GERMANY: Deutsche Gramophon-Aktiengesellschaft, 35, Ritterstrasse, Berlin, S42.
HOLLAND: American Import Co., 22a, Amsterd. Veerkade, The Hague.
HUNGARY: The Gramophone Co., Ltd., IV, Kossuth Lajos-Utca 8, Budapest.
SPAIN: Cia. Francesa del Gramophone, 56, Balmes, Barcelona.
SWEDEN: Skandinaviska Gramophon-Aktiebolaget, 52, Appelbergsgatan, Stockholm.

RUSSIA: The Gramophone Co., Ltd., 45, Nevsky Prospect, St. Petersburg; 9, Golovinsky Prospect, Tiflis; 30, Novia Svit, Warsaw.
EGYPT: The Gramophone Co., Ltd., 13, Rue Stamboul, Alexandria; Rue Mousky, Cairo.
EAST AFRICA: Bayley & Co., 8 Beira, Lourenço Marques.
SOUTH AFRICA: Darter & Sons, Adderley St., Cape Town; Mackay Bros., Rissik Street, Johannesburg; Mackay Bros. & McMahon, 443, West Street, Durban.
INDIA: The Gramophone Co., Ltd., 139, Ballighatta Road, Calcutta; 7, Bell Lane, Fort, Bombay.
AUSTRALIA: The Gramophone Co., Ltd., Hoffnungs Chambers, Pitt Street, Sydney.
GREAT BRITAIN: The Gramophone Co., Ltd., 21, City Road, London, E.C.

Great Britain:

The Gramophone Company Ltd
21 City Road London EC



ARRIVED AT LAST

"The World's Musical Instrument"

Gives *all* records the same chance!

SOON ON THE MARKET.

✿
Sounds
that are
truly
MUSICAL!



✿
Voices
that are
truly
HUMAN!

PLAYS TO PERFECTION,

without change of sound-boxes, EVERY disc record ever made and in such a realistic manner as never heard from any "Talking Machine," "Gramophone" or "Disc Phonograph" before.

(Read the views of the able Representative of this paper in London, about this new Instrument, on page 45 of last issue, March 15th, 1914.)

J. HOFFAY,

67 Egerton Gardens, South Kensington, London, England.

FROM OUR LONDON HEADQUARTERS—(Continued from page 46).

value, for they were sung by the picked opera singers of Italy, specially selected from a large repertoire of Italian records, all recorded in Milan, and issued at the popular price of 3s. 6d. Their reception was gratifying, and they sold steadily.

Since then, of course, many notable records have been added, such artists as Armanini (of Covent Garden), Amelia Karola, Pagganelli and Taurino Parvis among them.

This month sees further issues in this notable series, one of them a record by the great tenor Garbin, for whom Puccini wrote the tenor roles in two of his greatest operas. Another addition is Ferruccio Corradetti, never before available at this price, while Polverosi, a tenor of great renown in Italy, sings Lohengrin's Song from Wagner's opera in a style that would put many greater singers to the blush. And, finally, there is a remarkable record, by the Milan opera chorus, of "Glory to Egypt" from "Aida," which was specially sung for the Columbia complete issue of that opera, and is the only record extant of this magnificent chorus.

Chappell & Co. as Record Makers.

A recent event of great importance to the gramophone industry is the issue of disc records by one of our largest sheet music publishers, Messrs. Chappell & Co., Ltd., of New Bond street, London, W. The record is ten-inch double-sided, to retail at half a crown, and will bear the company's title, i.e., "Chappell." With such vast resources and influence at their command it is certain that quite apart from the good merits of the record itself, the issue will meet with a ready demand from the best class of dealers, and from the public at large. In conversation with your representative, Messrs. Chappell state that they have embarked upon this venture in order to ensure the publication in record form of their own copyrights as originally scored in so far as the limit of records will permit. The first five "Chappell" discs carry some of the latest musical comedy successes, and others are in course of preparation, in addition to a select number of the popular Chappell ballad concert favorites. From a tonal viewpoint, the "Chappell" record leaves nothing to be desired. It is marked by an all around excellence of quality and good volume, and traders are agreed that it will make a very wide appeal to all lovers of the musical art. Naturally, its advent has aroused keen interest in trade circles, where opinion is very divided concerning its effect. To our mind it is a significant move, and likely to exert a far-reaching effect upon the future policy of record companies, particularly in relation to the thorny question of orchestration, and as the copyright act says, "reasonable adaptation." These points, by the way, form the subject of a law action which is shortly to be heard. The result is being awaited by all gramophone houses with the keenest of interest.

Another New Instrument.

Inventors of late have been exercising their ingenuity along the line of improving the hornless gramophone. One of several which has recently made its appearance is "The Hornette," devised by F. W. Alderman, of the Pelham Trading Co., this city. This natty instrument occupies about a cubic foot of space, and as may be imagined, is very compact. It presents many new features of construction, the principle of which is its division into two parts, of course, hinged together. The lower part carries the motor outfit and tone arm, while the upper, which is in the nature of a lid, carries an interior horn. Thus the sound can be directed at any reasonable angle, a distinct advantage over the usual under-trumpet style of construction. In point of tone quality and volume the Hornette is quite the equal of any exterior-horn instrument. It is put up in solid oak and retails here at £5 10s.

To Imitate Wood.

Quite a new style of gramophone trumpets will be the vogue next season. They are of metal and enameled to imitate wood, mainly oak and mahogany. Those I was privileged to inspect at a large wholesale depot were so cleverly executed in the graining that at a short distance the differ-

ence between the real and imitation-wood horns was scarcely distinguishable.

New Companies Incorporated.

H. Morley Phillips & Co., Ltd., musical instrument dealers; capital £2,000. Office, 5 Aberdeen Buildings, Bromley, Kent.

Performing Right Society, Ltd. Limited by guarantee. Office, 32 Shaftesbury avenue, London, W. C.

New Columbia Artists.

The Columbia Co. list in its April supplement the first selections played by Cristeta Goni, the juvenile Spanish violinist, known abroad and in this country as "the Little Sarasate." Cristeta Goni is only fourteen years of age, but she has already achieved noteworthy fame as a finished artist in every respect. She was recently honored by being called to play before their Majesties the King and Queen of Spain.

This month again we have another important addition to the ranks of the artists represented in the half-crown records of the Columbia Co. in the person of H. Lane-Wilson, the celebrated baritone.

Mark to Denote British Origin.

The British Empire League recently convened a meeting under the presidency of the Duke of Argyll, in support of the proposal to institute a mark of origin to denote goods manufactured or produced in the British Empire. Among the reasons urged in favor of the scheme are that such a mark would provide a simple means of identifying British manufactures and produce; that it would support British industries and labor; that it would prevent the sale of foreign goods as British; and that, at the same time, it would bind more closely together the Mother Country and the Oversea Dominions. A resolution was unanimously adopted strongly urging the Board of Trade to proceed with the registration of the mark applied for.

Decision in Favor of Pathé Frères.

From time to time I have chronicled the legal proceedings in connection with what is known as the Holtzweissig hornless machine patent owned by the Gramophone Co., who recently took action in Germany against Messrs. Pathé Frères for alleged infringement. The matter has been argued first in favor of one and then the other company in two courts, and finally on appeal to the highest tribunal, the Reichsgericht, who find that the patents apply only to a special structure where the trumpet or sound amplifying chamber is placed underneath the cabinet. Messrs. Pathé Frères instrument is constructed differently, and therefore the result of this latest phase is in their favor.

Interesting List of Records.

His Master's Voice program for April constitutes an exceptionally fine aggregation of pleasing selections by their special artists, and although there can be no question of sifting wheat from chaff we would draw our readers' particular attention to just a few of the "star" records itemized on this supplement. Art in relation to the gramophone all must admit becomes more closely allied each month with the making of records by such distinguished and exclusive talent as the "H. M. V." company presents. This is exemplified in the list under review, for we are offered Sir Edward Elgar's newest work, "Carissima," by the Symphony Orchestra, under his own baton. It is a record of superlative excellence and very naturally has aroused wide interest in the trade. Another fine issue is "Die Beiden Grenadiere" (The Two Grenadiers), by Dr. George Henschel, with pianoforte accompaniment by himself. As singer, pianist, teacher, conductor and composer, this talented musician bears a reputation of world-wide fame, and this first record will therefore make a special appeal to record enthusiasts everywhere. The complete list as hereunder presents an amazing variety of music—something to meet every whim, every taste. Twelve-inch, double-sided: Slavonic Rhapsody, Op. 114 (Carl Friedmann), and "La Feria," Suite Espagnole (P. Laceme), Bournemouth Municipal Orchestra; Petite Suite Moderne I, "In a Country Garden," and II,

"Nocturne" (F. Rosse), Mayfair Orchestra; "On the Old Fall River Line," medley, one step or turkey trot (Von Tilzer), and "You're My Girl," medley, two step, Metropolitan Band.

Ten-inch, double-sided: "A Lover in Damascus Suite," "Beloved in Your Absence," "How Many a Lonely Caravan," and "Allah Be With Us"; "A Lover in Damascus Suite," "Where the Albana Flows" and "Far Across the Desert" (Amy Woodforde-Finden), arr. by Percy Fletcher, Band of H. M. Coldstream Guards; "Prehistoric Zig Zags," intermezzo, two step (Norman Kennedy), and "I want Some Loving" (Ben Styler), Mayfair Orchestra.

Twelve-inch, single-sided: "Parsifal," Charfreitagszauber (Good Friday music), part I. (Wagner), Berlin Philharmonic Orchestra; "Parsifal," Charfreitagszauber (Good Friday music), part II. (Wagner), Berlin Philharmonic Orchestra; "To Mary" (M. V. White), Ben Davies; "Sweet Early Violets" (L. F. Sherrington), Hubert Eisdell; "The Way, the Life" (del Riego), Miss Alice Lakin; "Hosanna" (Granier) (in French), Caruso; Pizzicato, Sylvia Ballet (Delibes), Mme. Lydia Lipkowskaya; "In Sheltered Vale" (old German song), Robert Radford; "Andante Spianato" (Op. 22) (Chopin), Mark Hambourg (piano); "Developing a Photograph" (Graves and Evans), Geo. Graves and Will Evans; "A Tango Dream" (Elsa Maxwell), Miss Grace La Rue; "Oh! Lor!" (Winifred O'Connor), G. P. Huntley; "Cheer, Boys, Cheer!" (Tom Clare), Tom Clare.

Ten-inch, single-sided: "There is a Flower That Bloometh" (Wallace), John McCormack; "The Brook" (Dolores), Miss Alma Gluck; "The Harvest Dance" (R. Batten), Stewart Gardner; "Berceuse" (Townsend), Fritz Kreisler (violin).

Some Excellent Issues.

The standard of quality on half-crown records to-day is even higher than that of the five-shilling records of a few years ago, says the Columbia Co. in drawing attention to their April list of talent.

Some excellent issues are to be found, such as the Peerless American Quartette's singing of "Salvation Nell"; the playing of "Semiramide," by the Milan Symphony Orchestra under Maestro Romani; Mme. B. de Pasquali's beautiful singing of "Thou Brilliant Bird" and "Villanelli"; Thorpe Bates' ten-inch record of "Fairings," and Haydn Woods' "The Sea Road."

A new record by David Bispham is always greeted with delight, for it may be safely said that no records offer such a satisfying return for the purchase price as those by this great artist at four shillings on Columbia-Rena. His admirers will be glad to hear his artistic rendition of Hodson's dearly loved song, "Tell Me, Mary, How to Woo Thee."

"WHAT COME YE OUT TO SEE?"

Whole-hearted criticism of Reed Miller, the tenor, is found in the following from the Emporia Gazette: "As a general thing, tenors assay at the rate of thirty cents a car in Emporia, but Reed Miller can come back here any old time, and find a room with a bath waiting him. After listening to him for a few strains, one doesn't have to wonder why phonograph companies fight for his oratorio records. Miller closely resembles Bill Colyar's head barber; otherwise he is a perfect Apollo."

Statement of the ownership, management, etc., of The Talking Machine World, published Monthly at New York, required by the Act of August 24, 1912.

Name of	Post-Office Address
Editor, EDWARD LYMAN BILL	373 4th Ave., N. Y.
Managing Editor, J. B. SPILLANE	373 4th Ave., N. Y.
Business Manager, AUGUST J. TIMPE	373 4th Ave., N. Y.
Publisher, EDWARD LYMAN BILL	373 4th Ave., N. Y.
Sole Owner, EDWARD LYMAN BILL	373 4th Ave., N. Y.

The Talking Machine World, Per August J. Timpe, Business Mgr Sworn to and subscribed before me this 16th day of [SEAL] March, 1914.

Eugene R. Falck, Notary Public 4
(My commission expires March, 30, 1916.)



Columbia records on sale the 20th of the month instead of the 25th—



(Write for "Music Money," a book "full of meat" for those dealers interested in quick and frequent turnover of capital.)

**Columbia Graphophone Company
Woolworth Building, New York**

GRAFONOLA AT WINTER RESORT.

Management of Tampa Bay Hotel, Tampa, Fla., Testify to the Satisfying Quality of the Columbia "Mignonette" for Entertaining Their Guests During the Past Season.

(Special to The Talking Machine World.)

ATLANTA, GA., April 6.—The local store of the Columbia Graphophone Co. received a few days since a very interesting letter from the Tampa Hardware Co., Tampa, Fla., Columbia dealer, enclosing a note of appreciation from the management of the Tampa Bay Hotel, Tampa, Fla., one of the best known winter resort in this section of the country. This hotel was but recently equipped with a Columbia "Mignonette," and the manager states that the machine has given his guests more pleasure than anything he ever introduced.

He is particularly delighted with the Columbia dance records, and remarked that his guests would rather dance to the music of Columbia records than with the regular hotel orchestra. This, the manager ascribes to the perfect tempo of the Columbia dance records, due to the supervision given their production by G. Hepburn Wilson, the prominent New York dancing expert. The Tampa Hardware Co. closed the sale of this machine to the Tampa Bay Hotel, and is now featuring to excellent advantage the letter that was sent them.

Westervelt Terhune, the popular manager of the local store, states that during March he secured more new Columbia dealers of the best ranking than in any month of this store's history. Among these new dealers are John A. Cunningham, Jacksonville, Fla., a prominent piano dealer, handling the Steinway and Aeolian lines and the Hamilton Green Piano Co., of Tampa, Fla.

HAVE TWO THRIVING STORES.

The R. L. Seeds Co., which now has two thriving exclusive Columbia stores in Columbus, O., this week signed a lease for ten years for a large and spacious building on High street near Town, at an average annual rental of \$3,600.

DUTY ON STEEL NEEDLES.

Held to Be the Same as the Talking Machines in Which They Are Used.

Steel needles used in talking machines were held last week by the Board of United States General Appraisers to be properly dutiable as parts of talking machines at 45 per cent. ad valorem, as provided for in Par. 468 of the tariff act of 1909. Landay Bros., of this city, were the importers. Judge Sullivan, in overruling the contention of the protestants to have the needles classed as manufactures of wire, says that it is established beyond dispute that the needles are of no use except in connection with the machines, and are used entirely in the production of records.

SUCCESS WITH THE LAUDER RECORDS

C. A. House & Co., Wheeling, W. Va., Feature the Records by the Famous Scotch Comedian During His Engagement in That City.

(Special to The Talking Machine World.)

WHEELING, W. VA., April 7.—A splendid follow-up to the theatrical engagement of a Victor artist was used recently by the C. A. House Music Co., the prominent Victor dealers of this city. Harry Lauder, the world-famous Scotch comedian was billed for several performances here, but owing to his fame and prominence, many of his admirers were unable to secure tickets to hear him.

Realizing the true state of affairs, the C. A. House Music Co. staged a Victrola recital immediately following Harry Lauder's engagement for the benefit of those who were unable to attend his performances. At this recital the Lauder records in the Victor library were featured, and the success of this timely recital work may be gleaned from the fact that the C. A. House Co. closed sales of fifty Lauder records and a Victrola XIV. and XVI. the day following the recital. In addition to these direct sales, it is hardly necessary to state that the company considerably enhanced its prestige by its thoughtfulness and consideration.

PHONOGRAPH'S SOCIAL VALUE.

Big Favorite with Boys in Social Center Clubs —Its Value Demonstrated.

Fifty boys attended the first meeting of the Social Centre Club for boys and young men in the Doylestown, Pa., high school the other night. They were reluctant to leave at 10 o'clock when Principal Carmon Ross, who is at the head of the movement, announced that it was time for boys to "turn in," "Give us more selections on the phonograph," they shouted.

So, there was interest, certainly, for one night. At least fifty boys were kept off the streets and from unworthy associates and associations.

The idea of Mr. Ross and his associates have in this work is to give the boys something better than they will find on the streets and to get them in the habit of wanting these better things rather than corner loafing. In reaching that end it is proposed to have the larger boys help with the work and be a part of the movement. The Edison phonograph was used and the Blue Amberols did the entertaining.

APPRECIATION OF THE VICTROLA.

A copy of Gossip, a paper for the home, published in Austin, Tex., contained recently the following appreciation of a Victor-Victrola, incidentally forming an excellent piece of publicity for the J. R. Reed Music Co., Victor dealers in that city:

"To keep the family gathered around the home and fireside, or to amuse the lonely man or woman without a family, there is nothing better than a Victor Victrola. At your own sweet will you merely slip in a record and Caruso or Melba will sing, a noted pianist will play or a famous orchestra will give anything from a frivolous rag-time to the most classical composition. If interested in Victrolas and the late records, be certain to visit the J. R. Reed Music Co.'s Victrola rooms."

**HERMANN THORENS, Ste. Croix (Switzerland)
TALKING MACHINE WORKS**

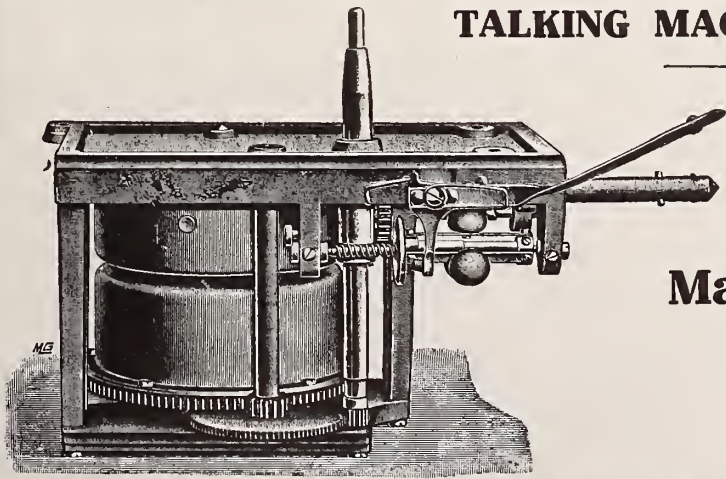

Motors and Sound Boxes a Specialty

CONCEDED TO BE THE BEST MANUFACTURED
OVER THIRTY DIFFERENT STYLES

**Machines with or without Horns
FIRST QUALITY ONLY**

**Noiseless Motors
HIGHEST RECOMMENDATIONS**

WRITE FOR DESCRIPTIVE CATALOGUE

THE RIMINGTON COLOR ORGAN.

Elaborate Battery of Colored Diaphragms Produce Color Music Which Works on the Emotions as Sound Music Does—Future of Instrument Lies in Combination with Music.

We may soon be dancing to the silent rhythm of colored lights if an instrument described in the Scientific American by John W. N. Sullivan should ever come into popular use. This is called the Rimington Color Organ. It consists of a keyboard controlling an elaborate battery of colored diaphragms, through which the light of a powerful arc lamp pours. Any color or combination of colors can be played and their intensity can be heightened or lessened at will, just as musical sounds can be played upon a piano. "Color music," Prof. Rimington calls it. It is intended to work upon our emotions much in the same way as sound music does.

"Imagine a darkened concert room," writes Prof.

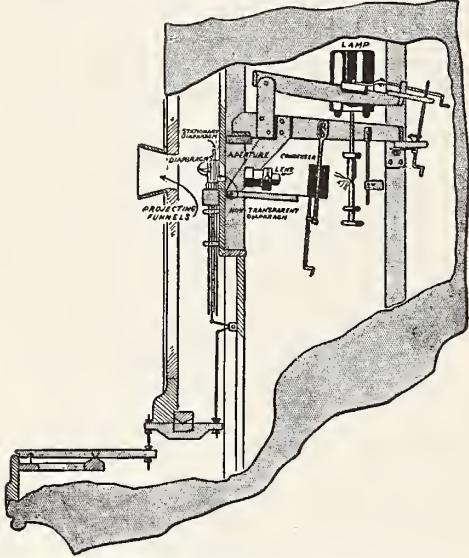

Diagrammatic Section Showing How the Color Music Is Produced.

Rimington in his book, "Color Music." "At one end there is a large screen of white drapery in folds surrounded with block and framed by two bands of pure white light. Upon this we will suppose, as an example, that there appears the faintest possible flush of rose color, which very gradually fades away while we are enjoying its purity and subtlety of tint, and we return to darkness. Then, with an interval, it is reported in three successive phases, the last of which is stronger and more prolonged.

"While it is still lingering upon the screen a rapid series of touches of pale lavender notes of color begin to flit across it, gradually strengthening into deep violet. This again becomes shot with amethyst and afterward, changing into a broken tint of ruby, gives a return to the warmer tones of the opening passage.

"A delicate primrose now appears, and with little runs and flushes the pulsation leads through several passages of indescribable cinnamon color to deep topaz. Then suddenly interweavings of strange green and peacock blue, with now and then a touch of pure white, make us seem to feel the tremulousness of the Mediterranean on a breezy day, and as the color deepens there are harmonies of violet and blue-green which recall its waves under a tramontana sky. More and more powerful they grow, and the eye revels in the depth and magnificence of the color as the executant strikes chord after chord against the bass notes of the instrument.

"Then suddenly the screen is again dark, and there is only a rhythmic and echoing beat of the dying color from time to time upon it. At last this disappears also, and there is another silent pause, then one hesitating tint of faded rose as at the opening of the composition.

"Upon this follows a stronger return of the color, and as the screen once more begins to glow with note after note of red and scarlet, we are prepared for the rapid crescendo which finally leads up to a series of staccato and forte chords of pure crimson which almost startle us with the

force of their color before they die away into blackness."

The mechanism is better understood from the accompanying diagram than it would be from a description. The illumination is furnished by a 13,000 candle-power arc lamp. An octave of the keyboard responds to a complete spectrum, the intensity of the color depending upon whether one, two or more octaves are played. There is an ingeniously devised screen for making a color appear and disappear gradually.

Prof. Rimington believes that the future of this instrument lies in combination with music. The colors of sounds are no new discovery. Lavignac, for instance, says the timbre of an oboe is rustic green and the blast of a trombone is heavy crimson. The art of color music is in its infancy, but its possibilities are wide.

The great trouble with the orchestration of colors is that different persons hear the same color differently—a note that is blue to one might be pink to another.

COLUMBIA WITH CHRISTMAN.

Arrangements Closed Last Month Whereby Christman Sons, 25 West Fourteenth Street, Will Handle the Complete Line of Columbia Products—Will Be Given a Very Handsome Display in Their Attractive Warerooms.

The Columbia Graphophone Co. closed arrangements on March 25 whereby Christman Sons, 35 West 14th street, New York, the well-known and successful piano house, will handle the complete line of Columbia products. This deal has been under consideration for some time, and with the consummation of arrangements recently, the Columbia Graphophone Co. adds to its list of local representatives another live-wire and progressive piano house.

Christman Sons handle the products of the Christman Piano Co., New York, and their marked success is evidenced in the fact that the firm but recently more than doubled their available wareroom space. Christman Sons are planning to institute an aggressive campaign on behalf of the Columbia products, and will display the machines prominently in their show-window and demonstration booths.

RECOVERS FROM SEVERE ILLNESS.

A. J. Smith, proprietor of the A. J. Smith Piano House in Clinton, Ia., who was recently operated on for appendicitis at Mercy Hospital, is improving after a very critical period of illness, much to the gratification of his many friends.

DECISION IN HILL PIANO CO. CASE.

Judge Hazel, in United States District Court Affirms Order of Referee in Bankruptcy Regarding Disposition of Property of Company.

(Special to The Talking Machine World.)

BUFFALO, N. Y., March 31.—Judge John R. Hazel, here in United States District Court, handed down an opinion in the matter of the Hill Piano Co., of Jamestown, N. Y., bankruptcy case, the opinion affirming the order of Referee in Bankruptcy Leslie A. Pease as to the disposition of the property of the company by the trustee. The opinion was written on the petition for a review of the referee's order. The question submitted to the attention of Judge Hazel was that as to the right of the unsecured creditors to decide as to the disposition of the property pledged to certain secured creditors, and as to the right of the referee to direct delivery by the trustee of this particular property. The meetings of the Hill Co. creditors have been filled with arguments and disputes as to whether the unsecured creditors had a voice in the sale or other disposition of the property. Finally the referee made this order affecting the trustee's action and certain other creditors immediately petitioned for a review by Judge Hazel.

In the court's opinion it was stated that while there was a suggestion in a measure of collusion and connivance among certain of the unsecured creditors at the beginning of the proceedings, this suggestion lost force in view of recent bankruptcy sessions of the case. Confirmation of the order directing the delivery of the property removes the necessity of litigation in the State courts.

TALKING MACHINE EXPORTS.

The Figures for January Presented—Reports Show Falling Off for the Month.

(Special to The Talking Machine World.)

WASHINGTON, D. C., March 30.—In the summary of the exports and imports of the commerce of the United States for the month of January (the latest period for which it has been compiled), which was recently issued by the Bureau of Statistics of the Department of Commerce and Labor, the following interesting figures relating to talking machines and supplies are set forth:

The total exports of talking machines, records and supplies for January, 1914, amounted to \$209,805, as compared with \$210,770 for the same month of the previous year. The seven months' exportation of talking machines, records and supplies amounted to \$1,671,680.

Special

Send for a package of our Improved Half-Tone and Loud Tone Needles in New Style Envelopes.

If you want to advertise yourself, we will put your own name or trade-mark on the envelopes, or will pack in Puritone envelopes.

Quality Guaranteed

The Best Needles mean profit and satisfaction.

If you want to sell 1,000 Needles at a time instead of 100, use the "Dean-packed" Needles. Five boxes of 200 each, Extra Loud, Loud, Opera, Medium and Soft packed in a carton. The best package and fastest seller on the market. Write for samples.

JOHN M. DEAN, CORP.

Talking Machine Needle Manufacturers

PUTNAM, CONN.

"STAGE FRIGHT" BEFORE THE TALKING MACHINE.

Thomas Chalmers, in the Century Opera Program, Tells of Embarrassment Felt by All Singers When Facing the Horn in the Recording Laboratories Which Is Never Completely Overcome—Constant Fear of Making a Break the Cause of Nervousness.

Many singers, if not all, have felt the particular variety of "stage fright" that attacks one when making phonograph records. Although it diminishes as one continues to record successfully, it never wholly disappears. There is something about a recording room—with the devouring horns that face a singer, and the feeling that the sins of commission and omission are never to be forgiven nor even forgotten—that is more demoralizing than the ordinary "stage fright" of the theater.

The unforgivable sin in a record is a "frog" (a slight break or huskiness), a thing which, in the theater, is almost imperceptible, but which, on the record, is a blemish that is fatal. It may be easily understood that hearing a singer sing the same song hundreds of times, and always hearing him break on the same spot, is enough to cause the average listener after a few hearings to hear only that one blemish and finish by hurling the record out of the window and vow solemnly never to buy another record made by that singer.

It is this very fear of "frogs" and determination to avoid them that very often are their cause—given a few bad starts, and it seems almost impossible to get away from them; although a singer may leave the recording room after such an experience and when the nervous strain is over find his voice as clear as a bell. A similar nervousness that I feel in the theater is caused by the dread of forgetting the words; and in that case also your fear is your worst enemy.

A very real and considerable difficulty in the making of records is that the singer does not hear his own voice in the same way that he hears it when singing in a large auditorium. You hear it—but differently. It is gathered into a horn and never comes back to you as it does under other conditions, a fact which is very disconcerting at first and always makes it difficult. You have to sing by "feeling" alone and are denied the aid of your ears, which aid is very great, as every singer knows. I have sung in many acoustically bad auditoriums, but never in one as bad (from the singer's standpoint) as the recording room.

However, in spite of, or on account of, these difficulties (probably the latter), it is extremely interesting work. In these days when there seems

to be a general understanding of the educational and moral influence of music, when financiers and governments are spending large sums of money to provide music for all, and are being lauded for their philanthropy, let us give Mr. Edison the credit and thanks for the greatest work of all—the phonograph. In the last few years it has done more to make music a part of every man's life than all the opera houses, symphony orchestras and musical organizations in the world. It has made the success of the Century Opera House in New York a possibility.

The experiment had been tried many times of giving New York popular-priced opera and always disastrously, but in the last few years, thanks to the phonograph, a sufficient musical taste among the public has been created to support such an institution. A small but surprisingly illuminating example of the power of the phonograph is found in the fact that one of the big publishing houses, quite a number of years ago, published an English translation of the great tenor-baritone duet from "Forza del Destino." They did so probably from the knowledge of its great musical worth and trusted to that to secure a sale for it. It was practically unknown and the sales were so small that the plates were destroyed. Thanks to a very well-known record of that number made by two great singers, it is to-day almost universally known. It is one of the most popular of concert numbers; has been retranslated and extensively sold.

Recording is one of the greatest aids to a singer's diction. If more singers recorded in English there would be less talk of bad diction for the primary requirement for a good record is that the text be understood, and unless a singer is able to sing the words distinctly he is useless from a phonograph standpoint. The sooner the general public are as critical as the phonograph public in this matter of diction, the better it will be for opera in English, for half of the value of opera or music drama lies in the audience understanding the dramatic value of the text.

Without that comprehension it is not complete. When it is sung in a foreign tongue, or in the vernacular indistinctly delivered, it ceases to be music-drama and becomes music and pantomime.

over Buffalo are now talking of the stunt and say it is one of the greatest ever publicly displayed.

WILL REWARD INVENTORS.

Marshall Heads Evans Committee to Lessen Industrial Mortality.

(Special to The Talking Machine World.)

WASHINGTON, D. C., April 8.—Vice-President Marshall, Speaker Clark, Secretary Houston, Secretary Wilson, Robert McKay, editor of The Railroad Man's Magazine; H. C. Young, editor of Popular Electricity, and President Samuel Gompers, of the American Federation of Labor, have accepted membership on a committee to select judges who will award prizes of \$1,000, \$300 and \$200 to inventors of the best devices to prevent accidents in industrial pursuits and the contracting of vocational diseases. The prizes are offered by Victor J. Evans, a Washington patent attorney, who paid Harry Atwood, the aviator, a cash prize of \$10,000 for flying from St. Louis to New York.

The formation of the committee, headed by Vice-President Marshall, is the outgrowth of agitation over a pending bill creating a Bureau of Labor Safety in the Department of Labor. The bill has passed the House and is now under consideration by the Senate Committee on Education and Labor.

R. S. Williams & Sons Co., Ltd., Toronto, Can., Edison disc jobbers, celebrated its 65th anniversary recently by a special musical program and an "at home" reception. It was the anniversary also of the company's first year in its new store.

How To Make Dollars

Yes, and how to make them grow with a comparatively small outlay of time and money.

That topic ought to interest you, Mr. Talking Machine Dealer!

Just figure how admirably you could work in pianos with your present line.

By pianos we mean those which are called both straight and player-pianos—in fact, every member of the piano family, including grands; but the main thing is to get your instruments right. In other words, at values which insure you liberal profits.

We have helped many a piano merchant to become a successful business man, because we have given him values which were not obtainable elsewhere, and we can help you. We can help you to show profits which will be particularly pleasing.

We would suggest that you do not delay an investigation of this matter, but take it up to-day—right now.

Don't waste your most valuable asset—time—by delaying too long!

H. P. NELSON COMPANY

Makers of Grands, Uprights and Player-Pianos

North Kedzie, North Sawyer, West Chicago Aves. and C., M. and St. Paul R. R., CHICAGO.

VICTROLA SCORES GREAT HIT.

New Invention of the Federal Telephone Co., the Muslaphone, Utilized to Convey Victor Music Throughout Elmwood Music Hall, Where the Great Electric Show Took Place.

(Special to The Talking Machine World.)

BUFFALO, N. Y., March 30.—Buffalo's great electric show which recently closed proved to be a great success. It is estimated that more than 50,000 people went to the Elmwood Music Hall during the show to view the great modern achievements in the world of electricity. All the latest inventions in the electrical mechanism were exhibited and the throngs of onlookers marveled at the great show.

The feature of the entire week was a continuous concert given by a Victrola machine. The way this was worked is simply something wonderful. The Federal Telephone Co. has a new invention called the muslaphone, which is similar to the telephone. At one end of the spacious and brilliant hall was a Victrola. To this was attached wires which connected several hundred funnels in the ceiling. As the sound of the Victrola issued forth, the sounds came from these funnels simultaneously, bringing out the strains of sweet and cherished music, while the crowd looked on in wonder. Despite that one night there were over 8,000 people passing in and out the hall the noise which the crowd naturally created did not dim the sounds of music from the Victrola. Even the band which was in attendance could not drown out the sounds from this wonderful machine with the aid of the muslaphone. People all

LATEST PATENTS RELATING TO TALKING MACHINES AND RECORDS

(Special to The Talking Machine World.)

WASHINGTON, D. C., April 10.—PHONOGRAPH RECORD, F. H. Gregory, Philadelphia, Pa. Patent No. 1,089,835.

One object of the invention is to provide a novel form of record and supporting structure therefor whereby in conjunction with suitable mechanism it shall be possible to obtain and reproduce a sound record of practically any length; it being further desired that the "record" made according to this invention shall have its parts so disposed as to occupy but relatively little space, even though it be of comparatively great length.

Another object of the invention is to provide a record for a talking machine of such a nature that notes indicating its subject matter may be conveniently applied to it without material loss of

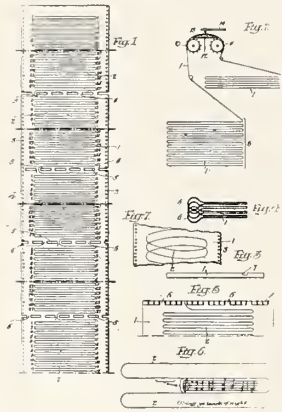

space and at any desired portion of its length; it being thus possible to provide a musical record with any desired directions for its rendition.

Another object of this invention is to provide a record supporting structure in the form of a ribbon or strip of any desired length, having a sound

record in the form of a line of varying depth or of an undulatory nature, arranged or placed upon it in such manner as shall utilize to the best advantage the record receiving surface.

Fig. 1 is a plan of a portion of a phonograph record constructed according to this invention; Fig. 2 is a diagrammatic view illustrating one method of using the record; Fig. 3 is a fragmentary section on a greatly enlarged scale, showing one of the features of the invention; Fig. 4 is an enlarged side elevation showing the disposal of the ends of successive sections when the record strip is folded; Fig. 5 is a plan of the strip shown in Fig. 4; Fig. 6 is an enlarged plan showing another of the features of the invention, and Fig. 7 is a fragmentary plan of a modified form of sound record.

SOUND BOX DIAPHRAGM.—John C. English, Camden, N. J. Assignor to the Victor Talking Machine Co. Patent No. 1,091,202.

This invention particularly relates to vibratory diaphragms for sound reproducing devices such as are co-operatively employed in connection with sound reproducing mechanism of a talking machine.

It is believed that diaphragms which in themselves are more or less resonant, and emit individual tones peculiar to their material or struc-

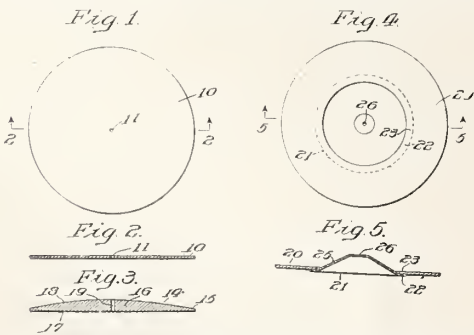

ture, produce vibrations which are sympathetic with, and to a considerable extent tend to interfere with tones produced by vibrations effected by sound waves of similar frequency, which it is desired to record, and which tend to cause disturbances which produce unpleasant and disagreeable sensations upon the ear of the hearer in the reproduction of a record.

The principal object of this invention is to pro-

vide a diaphragm which tends to obviate the difficulties experienced in diaphragms having an individual resonance by forming the diaphragm of substantially non-resonant material, preferably composed of a subereous formation.

Other objects of this invention are to provide a diaphragm of such extreme lightness and flexibility as to be capable of responding to, and reproducing the most minute and delicate sound waves, with all their overtones, and consequently to produce substantially the full volume of the original sounds; to provide a diaphragm of such uniformity as to produce substantially perfect recitation or reproduction of the original sounds; to provide a diaphragm formed of such resilient material as to be capable of being supported without employing gaskets and prevented from rattling by rigidly engaging its peripheral edge between the opposed faces of the relatively adjustable members of the sound box; and to provide a diaphragm which will adhere to the faces of the sound box members.

Further objects of this invention are to provide a diaphragm which is formed of a material readily obtainable; and to provide a diaphragm which is simple in construction, efficient in operation and which may be cheaply produced in any desired quantity.

In the accompanying drawing Fig. 1 is a face view of a diaphragm conveniently formed in accordance with this invention; Fig. 2 is a central transverse sectional view of said diaphragm, taken on the line 2-2 in Fig. 1; Fig. 3 is a view similar to Fig. 2 showing a possible modification of the diaphragm shown in Figs. 1 and 2; Fig. 4 is another form of diaphragm constructed in accordance with this invention, and Fig. 5 is a central transverse sectional view of the diaphragm shown in Fig. 4 taken on the line 5-5 in said figure.

SOUND BOX.—Thos. Macdonald, Bridgeport, Conn., assignor to the American Graphophone Co. Patent No. 1,091,001.

This invention relates to sound boxes for talk-

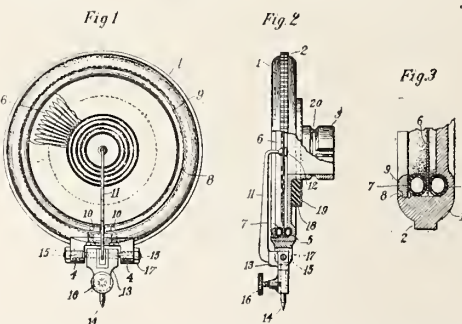

ing machines, particularly those of the type operating upon "zigzag" sound records. The objects of the invention are to cheapen and simplify the construction of the sound box, and to improve the quality of its audible reproduction.

The invention comprises the pivoting of the stylus lever upon a positive axis, consisting preferably of cone bearings and the locating of the stylus and of said axis in the plane of the diaphragm.

The invention further comprises the secure yet readily detachable mounting of the diaphragm in such manner that it is unconfined against vibrating with the utmost freedom. And, finally, the invention consists in the various details of construction and arrangement here pointed out and claimed.

Fig. 1 is a front view or elevation of this improved sound box; Fig. 2 is an edge view thereof, partly in section, and Fig. 3 is a detail, on an enlarged scale, showing the manner of securing the diaphragm in place.

A successful manager believes: That a sales manager's job is no bed of roses, and he must always keep ahead of his organization. He is always pushed to the limit by the live-wire men under him, who are always coming with new methods and ideas, their hearts filled with ambition to secure his job.

A HUSTLING WESTERN JOBBER

Is W. E. Kipp of the Kipp-Link Phonograph Co., Who Has Built Up an Excellent and an Expanding Business with the Edison Line.

One of the most strenuous and successful Edison jobbers in the West is W. E. Kipp, president, treasurer and general manager of the Kipp-Link Phonograph Co., Indianapolis, Ind. He has built up a solid business by tireless effort and closest attention to those minor details which are often overlooked, but which are ever essential to the man who desires to move ahead.

Year after year his Edison jobbing business has been expanding. He has an excellent line of dealers in his territory who rely on him and his com-



W. E. Kipp.

pany with the utmost confidence that their needs will be looked after with the greatest promptness and surety.

One of his greatest hobbies is taking care of the little things, for he well understands that it is the little things that count in building business. In fact, Mr. Kipp and his associates in the company are known as the 'Can't-Be-Beat Edison Jobbers of Indiana.' They are well maintaining this reputation and they have in vogue a system for handling the dealers' orders that is most admirable.

The Kipp-Link Co. has gained not only a host of friends in Indiana territory, but has lately reached out over the States of Illinois and Ohio, with no small degree of success.

There are evidently no slow ones in the Kipp-Link outfit, for every man in the house from the porter right up through the stock room, office, traveling force, to the men at the head of the business all are "on the job" developing business.

The success of Mr. Kipp, whose portrait is reproduced herewith, is a model that others may well emulate. Close attention to details, consideration of every need of customers—in brief, hard work—arc the means to the end.

There are probably sadder things in life than the man with an indifferent musical ear trying to play the accordeon. But no man, Manuel!

60 YEARS' EXPERIENCE

PATENTS

TRADE MARKS
DESIGNS
COPYRIGHTS & C.

Anyone sending a sketch and description may quickly ascertain our opinion free whether an invention is probably patentable. Communications strictly confidential. HANDBOOK on Patents sent free. Oldest agency for securing patents. Patents taken through Munn & Co. receive special notice, without charge, in the

Scientific American.

A handsomely illustrated weekly. Largest circulation of any scientific journal. Terms, \$3 a year; four months, \$1. Sold by all newsdealers.

MUNN & Co. 361 Broadway, New York
Branch Office, 625 F St., Washington, D. C.



Olive Fremstad may not be heard in opera on the stage, but she can be heard in opera on Columbia double-disc records. New recordings on sale in April.



(Write for "Music Money," a book "full of meat" for those dealers interested in quick and frequent turnover of capital.)

Columbia Graphophone Company
Woolworth Building, New York

PUSHING WILLIAMSPORT DEALER

Is the Pennsylvania Music Co., Controlled by Sweet, Reed & Franciscus, Who Handle Columbia Goods in Very Attractive Quarters.

(Special to The Talking Machine World.)

WILLIAMSPORT, PA., April 6.—One of the most attractive talking machine stores in this section is that of the Pennsylvania Music Co., controlled by Sweet, Reed & Franciscus at 209 West Fourth street. Columbia goods are handled exclusively and branch stores are controlled in State College, Jersey Shore and Muncy, Pa.

When noted artists come to this city they make this establishment their headquarters, and the com-



Showroom of the Pennsylvania Music Co.

pany is showing with some pride a photograph of Godowsky taken in the store listening to one of his records. Other recent visitors were Alice Nielson and other celebrities. The view of their store which appears herewith gives an excellent idea of its appearance and perfection of its equipment.

Mr. Franciscus, the general manager of this establishment, was for a number of years connected with the Metropolitan Opera House in Philadelphia, and became interested in the talking machine through the offices of Mr. Eckhart.

OLD ONE IN NEW DRESS.

Henry T. Finck tells an amusing story which he calls a new version of an ancient tale: "At a rehearsal Richard Strauss stopped the band and told the first trombonist that he was not playing the right note in a certain bar. The musician insisted that he was playing the note as printed; whereupon R. S. walked over to his desk, inspected his part, and found sticking to the page a dried fly which the trombonist had played as a note. Removing the fly, and returning to his desk, R. S. said: 'Now, play it as I had it printed.' The trombonist did so, whereupon R. S. again stopped the band and said: 'The fly was right.'"

RECORDS IN ALL LANGUAGES.

Proofs of Covers of Foreign Record Catalogs Just Sent Out by the Victor Co. Give an Idea of the Wide Scope Covered by This Company.

One of the most attractive announcements Victor dealers have received in some time was a multi-colored sheet recently sent out to introduce the front covers of all the new foreign record catalogs that the Victor Talking Machine Co. can now supply. This announcement sheet showed the covers of these new catalogs in their actual colors and designs, making a striking and impressive sheet that could not fail to hold the dealer's attention.

Among the foreign languages for which new Victor foreign record catalogs are now ready are the following: Portuguese, Dutch, French, French-Canadian, German, Russian, Ruthenian, Lithuanian, Slovak, Croatian-Servian, Servian, Roumanian, Turkish, Arabian, Swedish, Danish, Norwegian, Finnish, Spanish, Greek, Hebrew, Yiddish, Italian, Bohemian, Hungarian, Polish.

Accompanying this lithographed sheet of new catalog covers was an interesting announcement to the Victor dealers reading in part as follows: "There is a foreign population in your neighborhood.

Find out what nationalities are in your territory, the numerical strength of each, and then go after the business. We are ready to give you very substantial help by supplying various catalogs in foreign languages free of charge. The illustrations on this sheet show the front cover of all the different kinds we can give you—they are record catalogs and machine catalogs combined. In each separate catalog, and in each different section of any catalog covering more than one language, there are two pages setting forth the merits of the Victor in the languages of the people addressed. There are also two pages showing the various types of instrument. With these catalogs we will also supply window cards in French, German, Italian, Bohemian, Polish, etc., announcing the fact that records in that particular language can be obtained at your store." Surely good advice for the live dealer.

TRITON PHONOGRAPH CO. PLANS.

Disc Phonograph That Sells at \$10 to Be Handled Through State Agents or Jobbers, Who Will Sell to Dealers in Due Course.

The Triton Phonograph Co., 41 Union square, New York, is doing a lot of energetic work to promote the sale of the "Triton" phonograph—a machine that retails for \$10. The "Triton" is designed to accommodate the regulation size of disc

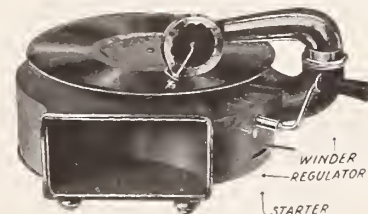

The Triton Phonograph.

needle records. It can be used in a small or large size room, and being only 11 x 13 inches in size and weighing but six pounds, it is easily carried on various excursions, outings, etc. In fact, the company also manufactures a traveling case of imitation leather with metal corners which holds this machine and a dozen records. The case itself retailing for \$1.

J. R. Kraus, manager, in discussing the policy of the company with reference to selling plans, stated that it is the intention to appoint State agents or jobbers, who in turn will look after the dealer market in each territory. It is Mr. Kraus' aim also to restrict the sale of this machine to one dealer in a city.

UDELL DISC CABINET CATALOG

Will Soon Be Ready for the Talking Machine Trade.

The Udell Works, Indianapolis, Ind., announces that it will soon have ready a catalog covering disc cabinets for the three makes of machines.

This concern has discontinued a number of styles, believing that it is better to concentrate upon the styles that are most in demand.

As this new volume will show the line as it is up-to-date, the dealer may feel sure that all of the models are of the style and quality that is guaranteed by the Udell Works.

THE PEOPLE SEEK FACTS.

Let the advertiser first know the ground floor, facts about his product and then tell them, steadily, persistently and all the time, right in the face of all ignorant criticism, however perverted it may be, and he will win out in time, for the people seek facts and ride over biased and self-seeking comment.

CHEMISCHE
FABRIK

E. SAUERLANDT

FLURSTEDT
bei Apolda i. Th., Germany

The largest manufacturing plant in the world devoted exclusively to the manufacture of Master-Waxes and Master-Blanks for

Gramophone and Phonograph Recording

Sole Manufacturer of

Wax "P." the best recording material for Berliner-cut.

RECORD BULLETINS FOR MAY, 1914

COLUMBIA GRAPHOPHONE CO.

SYMPHONY DOUBLE-DISC RECORDS. No. Size. By Oscar Seagle, the American Baritone. A5547 Hamlet (Thomas). Chanson Bachique (Drinking Song). In French, with orchestra. 12

2257 Ring on Sweet Bells (Geo. B. Nevin) Baritone and tenor, orch. accomp. Vernon Archibald-Royal Fish Tenor, orch. accomp. 12

PURPLE LABEL RECORDS. 60116 My Ain Countrie (Demarest-Hanna) Soprano Solo. Lucy Isabelle Marsh 10

SELECTED RECORDS LIST POPULAR.

Some Co-operative Work That Is Appreciated by Columbia Dealers and Customers.

As a valuable adjunct to its recently issued comprehensive catalog of records, the Columbia Graphophone Co. announced to its trade last week the compilation of a selected list of popular-priced Columbia double-disc records chosen from the general Columbia catalog and arranged alphabetically under various classifications.

The records listed on the pages of this catalog were chosen from the general catalog with special regard for the convenience of Columbia patrons in selecting a representative library of the popular-priced records that have been accorded the greatest favor by the public up to the present time.

Some idea of the scope of this auxiliary catalog may be gleaned from the fact that it lists records under every possible heading that a customer would be likely to desire. These headings include band music, dance selections, accordion numbers, hymns and sacred songs, orchestra records and many others.

WOULDN'T KNOW HOW.

"Have you any last words to say?" they asked the man about to be electrocuted. "I wouldn't know how," he said, "I'm married."

WHY OWN WEBSTER'S NEW INTERNATIONAL DICTIONARY THE MERRIAM WEBSTER? BECAUSE it is the only new unabridged dictionary in many years. BECAUSE it defines over 400,000 words, 2700 pages, 6000 illustrations.

THOMAS A. EDISON, INC.

BLUE AMBEROL REGULAR.

2252 Favorite Airs from "The Mascot" (Edmond Audran) orch. accomp. Edison Light Opera Co. 12



READE your trade paper! Get The Talking Machine World regularly—It is worth many times to you its annual cost.

There is but one talking machine paper covering this entire industry, and it is admitted by all that it is of great aid to the dealers in every part of this country.



New economic conditions make certain knowledge necessary on the part of merchants, and in every issue of The World there is contained educational matter, instructive service, business news and technical articles which are worth many times the cost of the paper.



Thousands have been benefited by the business articles which appear in The World, and every talking machine dealer should receive it regularly.



The only way to do that is to pay for it, and the cost is trifling—a little over eight cents a month, and for that small sum The World, with all its mine of information, is at your service.



If you do not receive the paper regularly, just put your dollar in an envelope and address it to the office of the publication, and you will say that it is the best investment that you have ever made.

Do not delay but send on your dollar now.

Recollect that your competitor is getting The World—getting it regularly, and in it he is securing some valuable pointers—information which places you at a disadvantage if you do not read the paper.

Do not overlook such a valuable contributing factor to your business success.

EDWARD LYMAN BILL

PUBLISHER

373 Fourth Avenue,

New York City



Three well-known Edison Salesmen are recommended to your consideration by Thomas A. Edison.

Their abilities to sell Edison Goods are certified to by him.

Turn to page 8 of this issue and see who they are.

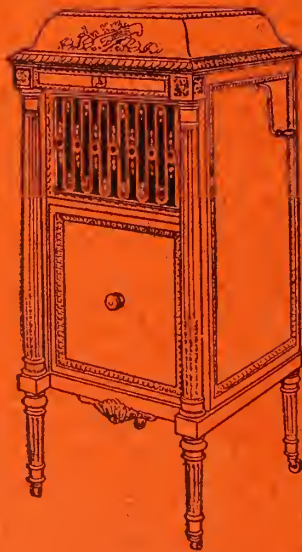

Louis XVI

Thomas A Edison
INCORPORATED

59 Lakeside Ave., ORANGE, N. J.

The TALKING MACHINE WORLD

AND
NOVELTY
NEWS

Published Each Month by Edward Lyman Bill at 373 Fourth Avenue, New York, May 15, 1914



A Corner of the Music Room
in the White House



Photo copyright by Waldon Fawcett, Washington, D. C.
Permission for reproduction granted to Victor Talking Machine Co., Camden, N. J.

Leading Jobbers of Talking Machines in America

Landay
BROS INC.

VICTOR JOBBERS Exclusively
What you want always in stock
400 Fifth Avenue
27 W. 34th Street
563 Fifth Avenue
153 W. 42d Street } **New York**

1856 **WURLITZER** 1914

VICTOR
DISTRIBUTERS
VICTORS EXCLUSIVELY

We make a specialty of getting the order out on time—every time.

The Rudolph Wurlitzer Co.
CINCINNATI and CHICAGO

Two points of supply; order from the nearer.

CHASE & WEST DES MOINES IOWA

Machines **Victor** Everything
Records in stock all
Cabinets the time.

WHOLESALE TO IOWA TRADE
Send us your name and address and we will mail you postpaid complete illustrated catalogues, giving detailed information concerning all Victor products. Showing the various styles of Victor Machines, list of all Victor Records, the entire line of Victor Cabinets, Repair Parts and all Accessories. Dealers, let us help you build a Victor business.

PERRY B. WHITSIT L. M. WELLER

PERRY B. WHITSIT CO.,

213 South High Street, Columbus, Ohio.

Edison Phonographs and Records **JOBBERS** Victor Talking Machines and Records

OLIVER DITSON COMPANY

Largest VICTOR Talking Machine Distributors East of Chicago.

Creators of "The Fastest Victor Service." Let us tell you more about our service.

BOSTON

W. J. DYER & BRO.
Saint Paul, Minn.

VICTOR & EDISON
Distributors

Quick Service for all points in the Northwest. Machines, Records, Supplies.

VICTOR DEALERS
TRY US FIRST

We carry the Largest Stock of VICTROLAS, RECORDS and CABINETS of any Distributor in the South.
THE CORLEY COMPANY, Richmond, Va.



Where Dealers May Secure

COLUMBIA

Product

Ready, Full Stocks, and Prompt Deliveries from Convenient Shipping Centers all over the United States.

Distributors

- Atlanta, Ga., Columbia Graphophone Co., 132 Peachtree St.
- Baltimore, Md., Columbia Graphophone Co., 305-307 North Howard St.
- Birmingham, Ala., Columbia Graphophone Co., 1818 Third Ave.
- Boston, Mass., Columbia Graphophone Co., 174 Tremont St.
- Buffalo, N. Y., Columbia Graphophone Co., 622 Main St.
- Chicago, Ill., Columbia Graphophone Co., 14 N. Michigan Ave.
- Cincinnati, O., Columbia Graphophone Co., 117-119 W. Fourth Ave.
- Cleveland, O., Columbia Graphophone Co., 913 Euclid Ave.
- Dallas, Tex., Southwestern Talking Machine Co., 1403 Main St.
- Denver, Colo., Columbia Stores Co., 505-507 Sixteenth St.
- Detroit, Mich., Columbia Graphophone Co., 114 Broadway.
- El Paso, Tex., Southwestern Talking Machine Co., Stanton and Texas Sts.
- Hartford, Conn., Columbia Graphophone Co., 719 Main St.
- Indianapolis, Ind., Columbia Graphophone Co., 27 N. Pennsylvania St.
- Kansas City, Mo., Columbia Graphophone Co., 112 Grand Ave.
- Lincoln, Nebr., The Grafonola Company, 1036 O St.
- Livingston, Mont., Schenber Drug Co.
- Los Angeles, Cal., Columbia Graphophone Co., 420-422 S. Broadway.
- Louisville, Ky., Columbia Graphophone Co., 425 South Fourth St.
- Milwaukee, Wis., Albert G. Kunde, 516 Grand Ave.
- Minneapolis, Minn., Columbia Graphophone Co., 424 Nicollet Ave.
- New Haven, Conn., Columbia Graphophone Co., 25 Church St.
- New Orleans, La., Columbia Graphophone Co., 933 Canal St.
- New York City, Columbia Graphophone Co., 89 Chambers St.; Columbia Graphophone Co., 35-37 W. 23d St.; Columbia Graphophone Co., 39 W. 125th St.
- Philadelphia, Pa., Pennsylvania Talking Mach. Co., 1109 Chestnut St.
- Pittsburgh, Pa., Columbia Graphophone Co., 101 Federal St.
- Portland, Me., Columbia Graphophone Co., 550 Congress St.
- Portland, Ore., Columbia Graphophone Co., 371 Washington St.; Eilers Music House.
- Providence, R. I., Columbia Graphophone Co., 119 Westminster St.
- Rochester, N. Y., The Grafonola Company, 38 South Ave.
- Sacramento, Cal., Kirk, Geary & Co.
- Salt Lake City, Utah, Daynes-Beebe Music Co., 45 Main St.
- San Francisco, Cal., Columbia Graphophone Co., 334 Sutter St.
- Seattle, Wash., Columbia Graphophone Co., 1511 First Ave.; Eilers Music House, 3d and University Sts.
- Spokane, Wash., Columbia Graphophone Co., 818 Sprague Ave.
- Springfield, Mass., Columbia Graphophone Co., 174 Worthington St.
- St. Louis, Mo., Columbia Graphophone Co., 1008 Olive St.
- St. Paul, Minn., Columbia Graphophone Co., 17 East Sixth St.
- Tampa, Fla., Tampa Hardware Co.
- Terre Haute, Ind., 640 Wabash Ave.
- Toledo, O., Columbia Graphophone Co., 229 Superior St.
- Washington, D. C., Columbia Graphophone Co., 1210 G St., N. W.

DEALERS WANTED—Exclusive selling rights given where we are not actively represented.

Write for particulars to the Columbia Graphophone Co., Wholesale Department, Woolworth Building, New York.

Headquarters for Canada:

Columbia Graphophone Co., 363-5-7 Sorara Ave. Toronto, Ont.

SANGER BROTHERS
Dallas, Texas

VICTOR
Distributors

"We ship the same day."

Southern Victor Dealers

Largest Stock VICTROLAS and RECORDS. Prompt Shipment and Low Freight Rates.

WALTER D. MOSES & CO.
Oldest Music House in Virginia or North Carolina.
RICHMOND, VA.

Edison Phonograph Distributors
for the SOUTHWEST

All Foreign Records in Stock

Houston Phonograph Co., HOUSTON, TEXAS

NEW ENGLAND
JOBBER HEADQUARTERS
EDISON AND VICTOR

Machines, Records and Supplies.

THE EASTERN TALKING MACHINE CO.
177 Tremont Street BOSTON, MASS.

PACIFIC COAST DISTRIBUTORS OF

Victor Talking Machines and RECORDS

STEINWAY PIANOS—LYON & HEALY

"OWN MAKE" BAND INSTRUMENTS

Sherman, Clay & Co. San Francisco Portland
Oakland Los Angeles

The Chicago Edison Jobber

The perfection of Musical Instruments—THE EDISON diamond disc PHONOGRAPH—with EDISON double disc records.

THE PERFECTION OF SERVICE—Our Service.

The Perfection of advertising for the dealer—Our plan.

The Phonograph Company
229 So. Wabash Ave. CHICAGO

Every Jobber in this country should be represented in this department. The cost is slight and the advantage is great. Be sure and have your card in the June List.

The Talking Machine World

Vol. 10. No. 5.

New York, May 15, 1914.

Price Ten Cents

W. STEVENS HOME FROM EUROPE.

Manager of Foreign Department of Thomas A. Edison, Inc., Completes Arrangements for Transferring European Business of Company to Orange—Increasing Popularity of Edison Products Abroad—Blue Amberol Liked.

Walter Stevens, manager of the foreign department of Thomas A. Edison, Inc., returned to Orange, N. J., recently after an extended trip to Europe, during which he visited, London, Berlin, Paris and other prominent European cities, but spending the major part of his time in London looking after the interests of the Edison companies.

Prior to Mr. Stevens' leaving for Europe the officials of Thomas A. Edison, Inc., had decided to transfer the entire European phonograph business to the main offices at Orange, leaving the various European branches free to concentrate their efforts on the development and cultivation of their moving picture film business. While abroad Mr. Stevens took care of the many details incidental to this important transfer.

Mr. Stevens found Edison products in Europe increasing their popularity steadily and consistently. The Blue Amberol records are proving ready sellers with the trade, while the advent of the Edison disc products is awaited with keen interest and expectation. In discussing the sale of records on the other side of the Atlantic Mr. Stevens remarked that there is a continued demand for ragtime selections, although there is a very heavy demand for dance selections. England particularly is manifesting an unusual interest in dance music.

SUIT AGAINST THE VITAPHONE CO.

Fred Stern, President of Chamber of Commerce of Newburgh, N. Y., Brings Action Against Plainfield Concern on Charge That It Failed to Keep Agreement to Move to Former City as It One Time Planned.

(Special to The Talking Machine World.)

NEWBURGH, N. Y., May 6.—Claiming that the Vitaphone Co., of Plainfield, N. J., a Delaware corporation, failed to live up to its agreement to locate a factory in Newburgh, N. Y., Fred Stern, president of the Chamber of Commerce of the latter city, has started suit in the New Jersey Supreme Court to recover \$500 paid for stock of the Vitaphone Co.

Papers in the suit were forwarded to Plainfield last week by Jacob L. Newman, attorney for Mr. Stern. As the parties concerned live in different counties the suit is brought in the Supreme Court. The Vitaphone Co. is authorized to do business in this State and has an officer here upon whom service may be made.

According to Mr. Stern's complaint, the Vitaphone Co. agreed to purchase property in Newburgh and build a factory for the manufacture of cabinets to contain the Vitaphone talking machine. With that understanding, Mr. Stern says, the citizens of Newburgh were prevailed upon to subscribe for stock. The Chamber of Commerce head says he bought fifty shares for which he paid \$500, receiving twenty shares of common stock as a bonus. He asserts that the Vitaphone Co. failed to buy any Newburgh property or locate a factory there.

The Vitaphone Co. manufactures its motors and assembles the metal parts in its factory at Plainfield. Mr. Stern says the agreement was that the motors were to be shipped to Newburgh for mounting in the cabinets to be manufactured there.

The Vitaphone Co. contends that the citizens of Newburgh failed to support the project and that it could not afford, therefore, to locate at Newburgh.

It is not so much what you are going to do as what you are doing that counts in the credit sheet.

MOVIES TO LEAD ORCHESTRAS.

Famous Conductors May Appear in Films in Dozens of Concerts at the Same Time.

A despatch to the New York World under recent date says that by means of films just placed on the market by the Meister Film Co. of Berlin the most famous musical directors will be enabled to conduct a dozen or more performances in different cities at the same time, and audiences of the future will be able to enjoy the conducting of great masters long after the musicians are dead.

This has been achieved by the use of master conductor films, and the film company will shortly give a huge concert here when all the most famous conductors will conduct by film-proxy.

Felix von Weingartner, after witnessing the first private performance, said:

"The success was extraordinary. The opera conducted was 'Carmen,' and the machinery for producing the film was so exact that after one trial the musicians were able to play with exactly the same accuracy as they would have done if a living conductor had been present. There is nothing mechanical about the performance, and the result is genius. A clever conductor can be transferred to a living orchestra for generations to come."

A number of well-known musicians have been invited to play in front of the moving films and a majority of them declare that the suggestive effect of movements shown on the film are quite as powerful as those of a living conductor.

The films already prepared show Weingartner conducting the "Egmont" overture, Geheime von Schuch of the Dresden Royal Orchestra conducting "Tannhauser" and Oscar Fried in Berlioz's symphony fantastique.

Arthur Nikisch says the new films are an epoch-making invention and adds:

"How valuable, for instance, it would be to the present generation if it could see exactly how Wagner conducted the ninth symphony at the famous Bayreuth festival in 1872!"

COLUMBIA CO. BRINGS SUIT

Against Several Companies for Infringement of Patents—Statement by Legal Department.

The legal department of the Columbia Graphophone Co. made the following announcement this week:

"The American Graphophone Co. owns and controls a number of United States patents relating to talking machines, records and accessories, and is the intention of the Graphophone Co. to attack infringements of their patent rights; and in earnest of its purpose it has already instituted several suits, among others against the American Parlograph Corporation, the Triton Phonograph Co., Inc., Gimbel Bros., and other suits are in course of preparation.

"Owing to changes in the practise in the Federal Courts it is uncertain at this time when these cases will be reached for trial; but the legal department of the American Graphophone Co., Mauro, Cameron, Lewis & Massie, New York City, expresses itself as ready for immediate trial and as entirely confident of success.

TAKES ON TALKING MACHINES.

(Special to The Talking Machine World.)

ANAHEIM, CAL., May 3.—The Graham Furniture Co., one of the largest and finest furniture houses in this part of the country, located in this city, has just taken on the agency for the Edison disc phonograph. Albert Graham, who owns and conducts the enterprise, will take a strong personal interest in the new department.

One realizes that what you get for nothing is worth just that, when a lot of voluntary advice is handed to you.

VICTROLA WINS SUPERVISORS.

Mrs. Clark Demonstrates Value of Victrolas in Schools at National Conference in St. Paul—Many Noted Musical Authorities Present.

(Special to The Talking Machine World.)

ST. PAUL, MINN., May 6.—The value of talking machines in school work was exemplified in a striking manner at the seventh annual meeting of the National Conference of Music Supervisors. Mrs. Frances E. Clark had almost a full line of Victrolas in the West Hotel, the headquarters of the convention, and her intelligent demonstrations of the use that talking machines might have in the schools attracted much favorable comment from the teachers. Many of the Minneapolis schools have instruments of various kinds and have been trained to distinguish between good music and trash, and the visitors were much interested to hear the young critics place their seal of approval or disapproval on a long series of musical numbers of varying order of merit. The program was made up of numbers which the youngsters had never heard before, and their unerring judgment, in picking out the good music, highly entertained the teachers.

Among those in attendance were: P. P. Claxton, United States Commissioner of Education; Will Carhart, Pittsburgh, Pa.; Theodore Fitz, Greeley, Col.; Miss Mary Conway, New Orleans, La.; Miss Elsie Shawe, St. Paul, Minn.; Charles Fansworth, Columbia University; P. W. Dykema, University of Wisconsin; Mrs. Elizabeth Casterton, Rochester, N. Y.; Charles Miller, Lincoln, Neb.; Dr. E. A. Winship, Boston, Mass.; Miss Frances Wright, Des Moines, Ia.; Ralph Baldwin, Hartford, Conn.; C. A. Fullerton, Cedar Rapids, Ia.; D. A. Clippinger, Chicago, Ill.; Arthur Mason, Columbus, Ind.; Miss Estelle Carpenter, San Francisco, Cal.; Miss Ida Fischer, San Jose, Cal.; D. B. Gebhart, Missouri Normal School, Kirksville, Mo.; Osburne McConathy, Northwestern University; Miss Lillian Watts, Marquette University, and numerous others of equal prominence in the musical world.

Their appreciation of Mrs. Clark's demonstration was universal, and the general verdict, if one had been called for, would have been that talking machines are indispensable in modern schools.

SETTLED IN NEW HOME.

American Phonograph Co. Completes Removal of Headquarters from Gloversville to Albany, N. Y.—Occupies Handsome and Commodious Quarters in the Latter City.

(Special to The Talking Machine World.)

ALBANY, N. Y., May 6.—The American Phonograph Co., the well-known Edison jobber, formerly of Gloversville, N. Y., is now fully settled in its handsome new home at 707-709 Broadway, this city. The building covers a floor space of 40x200, and the company occupies two entire floors.

The main floor is occupied by the executive and sales offices, and several attractively furnished soundproof booths are also located on this floor. Every possible convenience for the company's dealers is incorporated in the furnishings and sales systems in the new building, and a cordial invitation is extended to all Edison dealers to visit the American Phonograph Co.'s headquarters when in Albany. A splendid trade has already been closed in the new home, and the company is well pleased with the outlook. This company, which is an exclusive Edison jobber, has two traveling men who cover northern New York, northern Pennsylvania, Vermont, part of New Hampshire and western Massachusetts.

Don't keep shifting your footing on the Ladder of Success. You're apt to step on the fingers of the man below you.

BEAUTIFULLY ARRANGED TALKING MACHINE ROOMS

Are Those of the Silas E. Pearsall Co., the Old-Time Talking Machine House of New York, and of Which Charles Bobzin Is Now Manager—Illustrations Give an Idea of the Equipment and Artistic Arrangement—Possess a Certain Charm That Always Attracts.

The characteristics of splendor are fully in evidence at the Victor warerooms of the Silas E. Pearsall Co., of which Charles Bobzin is manager, 16-18 West Forty-sixth Street, New York,

seen the view in the Pearsall warerooms from the first booth looking toward the street. It is really but a glimpse of the actual store, and a visit to this place must be taken to really appreciate to



View of Pearsall Warerooms Looking Toward Street.

yet so artistically has the floor been arranged, that every detail is harmoniously related to its neighbor.

In one of the accompanying illustrations may be

just what extent these tasteful decorations enhance the interior beauty.

Finished throughout in light brown natural gum wood, with the decorative scheme in tints of brown,

EDISON DISC FOR MASONIC LODGE.

New Outfit Provides Excellent Means for Entertainment According to Officers of the Lodge—What De Witt C. Smith Has to Say.

(Special to The Talking Machine World.)

SAVANNA, ILL., May 7.—R. M. Garrett, the enterprising Edison phonograph dealer of this city, closed a sale of unusual interest recently when he sold a handsome Edison disc phonograph with a large supply of records to the Mississippi Lodge

385, A. F. and A. M., of this city. Edison disc machines have been placed in the lodge rooms of a number of prominent societies in this section of the country, and in every instance have given perfect satisfaction.

Mr. Garrett is featuring to splendid advantage the following expression of hearty praise sent him by De Witt C. Smith, the secretary of the lodge which recently purchased the Edison disc outfit:

"Since we have placed the Edison disc in our Temple it has been used very generously by members as a means of entertainment, and the unani-



Record Stock Room of Pearsall Co.

and furnished as luxuriantly as the Fifth avenue home, it is no wonder that this fashionable Victor headquarters numbers among its clients many of the wealthiest members of society.

This store is also the headquarters for the wholesale Victor business of the Pearsall Co., which has increased ten-fold since Mr. Bobzin assumed the managerial duties of the house. The record room, which is shown herewith, holds 100,000 records, while the storage rooms for machines contain a great many machines of all models. Thus the service rendered the dealers may be called "of speed and completeness," for Mr. Bobzin believes that the dealer comes first, and he aims to protect him in every instance. A great student of business conditions, Mr. Bobzin sees nothing but prosperity for the talking machine world in general, and, particularly, for his field mates in the Victor business.

mous verdict is that it is the right machine in the right place. Particular mention is frequently made by those who hear it that this is the last word in perfect tone reproduction."

MARRIAGE OF ABRAHAM DAVEGA.

The marriage of Abraham Davega, son of I. Davega, the well-known talking machine jobber, 125 West 125th street, will take place on June 18. This will be preceded by a bachelor dinner, at which time hosts of friends will tender him their good wishes.

The Success of Your Talking Machine Department

Is to a *large* extent dependent upon the service your distributor gives you.
This admitted makes it important that you secure the best service obtainable.

AND THAT IS EASTERN SERVICE

To use it is to swear *By* it not *At* it.

May we not have the opportunity to convince you that our service is exceptional?

EASTERN TALKING MACHINE COMPANY

177 TREMONT STREET, BOSTON, MASS.

EDISON

FOR NINETEEN YEARS TALKING MACHINES EXCLUSIVELY

VICTOR



The newest additions to
the exclusive Victor group
of the world's greatest artists

The policy of the Victor is to secure only the very best artists.
And it secures them because the Victor and Victrola alone
are able to reproduce their voices and art to absolute perfection.

Five artists who are the most recent to decide that only the
Victor can do justice to their voices, and are now under contract
to make records exclusively for the Victor, are:

Margarete Ober

the newest contralto addition to the Metropolitan Opera Co.

Emmy Destinn

the famous soprano of the Metropolitan Opera Co.

Giovanni Martinelli

of the Metropolitan—this season's "discovery" among tenors

Lucrezia Bori

the Metropolitan's new lyric soprano

Julia Culp

one of the most successful concert artists

Every new addition to the Victor ranks gives new prestige to the Victor and Victrola.

Victor Talking Machine Co., Camden, N. J., U. S. A.

Berliner Gramophone Co., Montreal, Canadian Distributors

Always use Victor Machines with Victor Records and Victor Needles—
the combination. There is no other way to get the unequalled Victor tone



FAMOUS RECORD ALBUMS

AT VERY LOW PRICES TO MEET COMPETITION

For Durability, Artistic Design and Finish, our Albums have no equal. They are made in the most substantial manner by skilled workmen.

Our Albums are first-class in every particular, and are sold at very low prices.

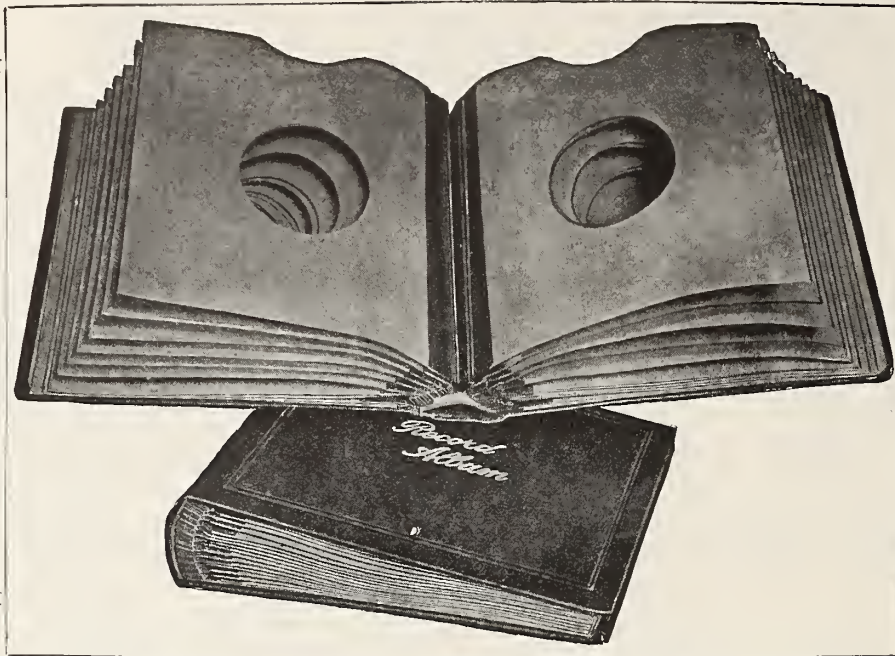

OUR SUPERB ALBUMS SHOWN OPEN AND CLOSED.

MADE IN TWO SIZES TO FIT ALL 10 AND 12-INCH DISC RECORDS.

These Albums contain 17 pockets made of strong fibre paper, each pocket having a hole in the center, as shown in the picture. These pockets are so made that they show very plainly both the single and double face titles on the Records. The Albums are bound in the finest quality of Brown Silk Finish Cloth, with gilt title on front cover. They are also bound in imitation leather. Write for sample and prices of our Albums, which are superior to all others.

Address NATIONAL PUBLISHING CO., 235 South American St., Philadelphia, Pa.

TWIN CITIES DANCE MAD.

Talking Machine Dealers Hard Put to Fill Demand for Dance Records—Tango Dancers Prove Strong Attraction at Cable Piano Co. Store—Records by Margaret Wilson Make Big Hit—Advance Demand Was Very Large.

(Special to The Talking Machine World.)

ST. PAUL, MINN., May 5.—St. Paul and Minneapolis have gone mad over dance music, and the dealers, whether they handle Victor, Columbia or Edison goods, hardly can supply the demand for terpsichorean records. The tango craze probably is responsible for the public craving for dance music, but, whatever the psychology of the condition may be, it is a gratifying one to the dealers.

One half of the Cable Piano Co.'s store in St. Paul is given up every afternoon to a pair of clever tango dancers, who draw capacity houses at each performance. Interest in the tango also is highly intensified by the appearance this week of the renowned Castles, both in Minneapolis and St. Paul. After their local engagements, it is fair to assume that the cities will be in an ecstasy of dance madness—and, at any rate, the dealers will try to help it along.

Columbia dealers receive many inquiries for the Margaret Wilson records, and C. P. Herman, manager of the St. Paul store, is looking for a big rush of sales. He reports the April sales as very satisfactory on the whole, though there was a falling off in business at the close of the month. His Dictaphone department is doing well, and the machine is making steady inroads in the business offices of St. Paul.

Archie Mathies, of the Talking Machine Co., handling Victor and Edison instruments, has discontinued the recitals for the summer season, but will resume the programs in the fall when people can be prevailed to come inside. Now they prefer the great outside.

The grand opera season, true to all predictions, helped the talking machine dealers considerably,

particularly in the matter of selling records. On the whole, there is a marked tone of satisfaction when the twin city dealers discuss local conditions.

HELD PARADE OF VICTROLAS.

W. H. Reynolds, of Mobile, Ala., Takes That Means of Impressing Local Residents with the Extent of His Victor Business and Stirs Up Much Interest and Good Business.

(Special to The Talking Machine World.)

MOBILE, ALA., May 8.—W. H. Reynolds, the well-known Victor distributor, recently received two carloads of Victrolas and decided to impress upon the music loving public of Mobile just what this large shipment signified, through the medium of a parade through the streets of the city before the Victrolas were placed in his store. This unique parade attracted general attention and comment, a number of newspapers mentioning it and referring to the rapidly growing popularity of the Victrola in this territory.

WANTED CARUSO IN "MISERY."

Geo. M. Richter, Jr., manager of the talking machine department of the Clark Music Co., Syracuse, N. Y., writing to The World under recent date, says:

"GENTLEMEN—Your comment in the April issue about salesmen having to be quick-witted at times, reminds me that very often we have such instances occur in our department. A few days ago a lady came in the store, and asked one of our salesladies if she had 'Caruso in Miserere'—but what she actually said was 'Have you Caruso in Misery?' To avoid embarrassment our clerk quickly handed her record No. 89,030, sung by Caruso and Alda. This suited her and she left contented and satisfied that she had it."

Diogenes didn't find the honest man because honest men haven't any great desire to be held up before the populace as worthy examples.

DISC RECORD ALBUMS

ARE WHAT EVERY

Talking Machine Owner

NEEDS AND MUST HAVE

With the index they make a complete system for filing away all disc Records, and can be added to, Album by Album, as Records accumulate, like books in a library.

A SUMMER SENSATION!

Two Dazzling Chicago Blondes Plan Unique Descent Upon Eastern Resorts—To Teach the Tango by Phonograph on the Beach.

Two beautiful blondes have arrived from Chicago to do something new in tango teaching.

Tall, lithe and fair, and with blue eyes, and Ethel Sykes and Dorothy Coffee by name, they were the tango sensations in the Windy City's lobster district all winter.

Their ultimate object in descending upon New York is to get speaking parts in stage plays. Heretofore their efforts in the uplift of the drama having been confined to motion pictures.

To keep their motor car in gasoline until September, the Misses Sykes and Coffee are going to take their tango scheme to the summer hotels along the Atlantic Coast.

These dazzling beauties purchased a Victrola on the instalment plan and thus will carry their own music with them.

They will put up at the Nassau Hotel at Long Beach, the Oriental at Manhattan Beach and the Marlborough-Blenheim at Atlantic City, and be ready at a moment's notice to teach the tango to anyone who may have the price, and their charges will be on a sliding scale, depending upon what the applicant has.

When they go in the surf, they will use alluring bathing suits, especially adapted to purposes of the turkey trot, and the Victrola will accompany them to the beach, and the sands will be turned into a ballroom. Those who have seen Miss Sykes and Miss Coffee in their bathing togs predict for them an overwhelming class when they teach on the beach, unless Anthony Comstock happens to wander along that way, when, well, you know what happened to September Morn!

An arbitrator is sometimes one who hears both sides of a quarrel and then decides to call the police.

JOBBER GET READY FOR REUNION AT ATLANTIC CITY.

Next Convention of the National Association of Talking Machine Jobbers to Be Held July 6, 7 and 8—Will Be Noteworthy in Many Respects Because of Its Educational Features—Committee Active in Perfecting Plans—Latest Developments of Interest.

The eighth annual convention of the National Association of Talking Machine Jobbers will be held at Atlantic City on July 6, 7 and 8.

The reason for choosing Atlantic City as the meeting place is set forth in the words of our talented and genial friend, James F. Bowers, of Lyon & Healy, Chicago, who once said: "There are only three places at which to hold conventions. The first is *Atlantic City*; the second is ATLANTIC CITY; and the third is ATLANTIC CITY!"

On April 18 J. C. Roush, of Pittsburgh, president of the association; L. C. Wiswell, of Chicago, chairman of the committee of arrangements, and Benj. Switky, of New York, met at Atlantic City to perfect plans for the most successful convention ever held.

The next convention will be noteworthy by reason of the educational features embodied in the program. The committee realizes that the mere offer of a good time is not in itself sufficient inducement for a jobber to travel from the Pacific to the Atlantic Coast. Therefore, they have set for themselves the task of making the next convention a good business proposition for every member who attends. This means that to be absent is to lose money.

In addition to the personal attendance of every member of every firm of distributors it is urged that association members bring along their managers, superintendents and right-hand men. There will be a mechanical exhibit and demonstration in Atlantic City such as has never before been attempted. It will be like bringing the mountain to Mahomet.

The why and wherefore of many things and policies that have puzzled the trade will be explained authoritatively by the men responsible for those things and policies. Questions of momentous

interest to both distributors and dealers will be discussed, debated and acted upon.

Members will find it to their interest to inspect the various lines of supplies and specialties that will be represented at the convention. Likewise, the opportunity of greeting factory officials should not be overlooked. Matters of personal interest can be taken up while visiting the East.

In order to induce members to bring along their wives, families and friends, a delightful social program has been arranged, in charge of special reception and entertainment committees. Automobile rides, luncheons, dances, cabarets, banquet, etc., are merely a hint of what is in store for members and their guests.

In addition to the business features, the plans of the arrangement committee include a banquet that promises to be one of the most enjoyable ever held under the auspices of the association. Arrangements have been made with Barney's Hotel, one of the most popular places in Atlantic City, to provide an enticing menu at a moderate price and to give the use of the regular hotel cabaret entertainers and orchestra for the entertainment of the diners. The banquet will be held on Tuesday evening, July 7, and the committee has also arranged for Mr. Barney to reserve the balcony in his cafe on Monday night for the association members and their friends, and from where they can watch the dancing on the main floor. Barney's will take the place of the Old Vienna this year, the latter place having closed, following the death of the proprietor.

Among the arrangements made for the entertainment of the ladies, while the convention is in session, is included an automobile trip to the Atlantic City Country Club on Monday, with luncheon at the club before returning.

The National Association of Talking Machine Jobbers has more than justified its existence. By reason of mutual interests it has banded together the jobbers of the United States. Through the officers and the executive committee many far-reaching and profitable results have been achieved. It is the duty of every member of the association to answer in person the roll-call at Atlantic City, if for no other reason than to show his appreciation of the excellent work of the executives and committeemen.

While the strength of the organization is measured by its membership, its vitality is gauged by the attendance at the annual convention. So get together, gentlemen. Don't shift it onto George. Be there yourselves. The convention dates were purposely chosen so as to blend with your Fourth of July celebration or your summer vacation.

CONCERTS FOR SHOPPERS.

An Excellent Means of Bringing the Talking Machine to the Attention of the Public.

A very excellent suggestion was that made by the Edison Phonograph Monthly, when it said: "Many dealers are located right in the shopping district. Here is a decided advantage if rightly used, and the advantage consists in the fact that so many women are doing the shopping and would be glad of a resting place just about noontime or shortly thereafter. The alert Edison dealer will not miss the opportunity. A recital planned at that time, will undoubtedly be well patronized, but some strong feature must be announced. One store recently announced that a contralto singer, prominent in a certain local church, would sing. The place was filled!

"But apart from the attracting of shoppers, there is great importance to be attracted right now to store recitals. By all means get the machinery in working order. Have an attendant who understands the Edison. See that the machine itself is in good shape and the records selected and ready to play. Make it a high-tone affair by a neat program, which may be varied from day to day.

Victrolas and Record Stocks Short

Be just to yourself and your customers

You owe it to yourself and your customers to give us a trial at filling your orders before you lose a sale by telling them that you "haven't got it and can't get it."

We cannot truthfully boast

about the completeness of machine and record stocks; nevertheless you can get from us certain types of machines and many selections of records that are not to be gotten elsewhere. New numbers are coming in daily.

TAKE NOTHING FOR GRANTED UNTIL YOU HAVE TRIED

BENJ. SWITKY, Victor Distributor NEW YORK, N. Y.



LOUIS XVI
Model A450, Circassian Walnut, \$450.00
Model A400, Mahogany, \$400.00



SHERATON
Model A275, Mahogany, \$275.00
Plain, \$275.00

Think About Your Different Kinds of Customers As Well As Your Line

Look at the goods you carry through other people's eyes.
Don't try to fit your customer to your line.
Sell the line that fits *all* your customers.

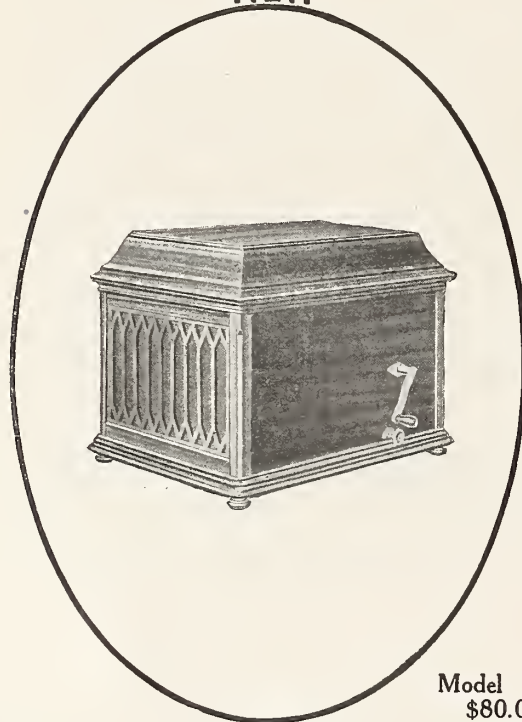

Model A80, Mahogany, \$80.00

Edison Phonographs

DIAMOND DISCS and AMBEROLLS

give you all the different kinds of phonographs which you need for all your different customers. They give your customers so unequalled a variety in Types, Models, Designs and Prices that their choice can never hesitate between the Edison and some *other* phonograph—it concentrates instantly on the Edison Line because its very size tells them that *some where* in that great line is the phonograph that *they* want.

Thomas A. Edison, Inc.



Model A200, Mahogany and Oak, \$200.00



Model A300 Circassian Walnut, \$300.00



BRATON
Model A290, Mahogany, Inlaid with marquetry, \$425.00

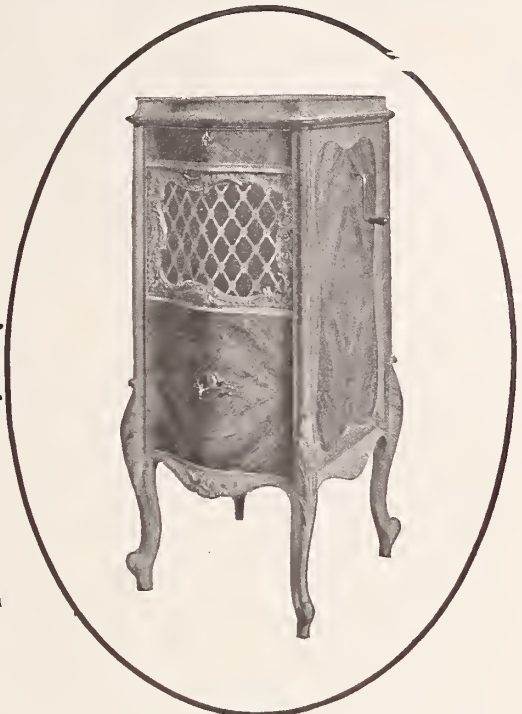

LOUIS XV
Model A425, Circassian Walnut, \$425.00
Model A375, Mahogany, \$375.00

Seven Customers Whom You Can Sell Right Away

Seven will buy Edison Phonographs from you right off the reel—and each one for a different reason. These seven buyers are:

- 1. The one who wants no bothering with needles.
- 2. The one who wants *all* the original music, overtones as well as fundamental tones.
- 3. The one who wants long playing records.
- 4. The one who wants records that the children won't break.
- 5. The one who wants steady speed and steady pitch.
- 6. The one who wants the only phonograph whose tone is suited to outdoors.
- 7. The one who wants his cabinet to match his indoor furnishings.

You want each of these seven customers to bring in seven more, and each of those to bring in still another seven, then you want the *full* Edison Line. Get in touch with your nearest jobber. Write us for his name now—to-day.

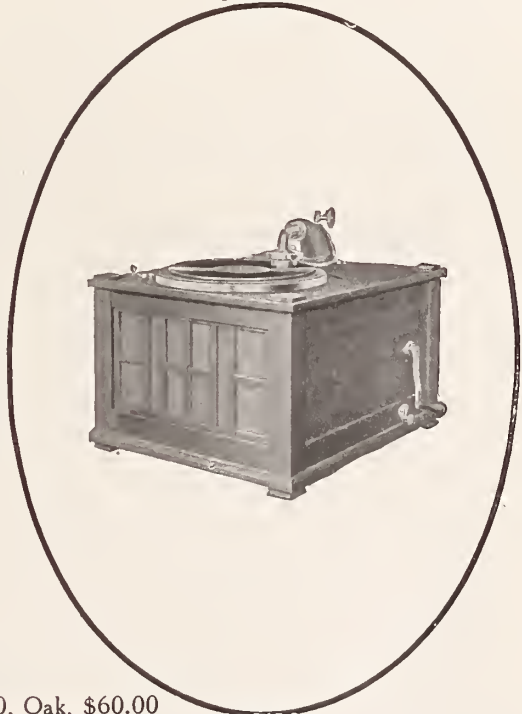

Model B60, Oak, \$60.00

Lakeside Ave., Orange, N. J.



Model A250, Mahogany and Oak, \$425.00



Model A150, Mahogany and Oak, \$150.00

CINCINNATI TRADE CONTINUES TO BE OPTIMISTIC.

Messrs. Rugles and Ahaus Invent New Needle Which Will Soon Be Put on the Market—
Millner Enlarging Victor Department—Whelan Tells of Columbia Expansion—Victor
Activity at Wurlitzers and Aeolian Hall—News of the Month Recorded in Detail.

(Special to The Talking Machine World.)

CINCINNATI, O., May 4.—P. B. Ruggles, a Cincinnati chemist, and Louis Ahaus, manager of the Victrola department of the Lyric Piano Co., have invented a new needle, which gives free use of the music without the scratching which so often mars the reproduction.

Messrs. Ruggles and Ahaus are preparing to put their invention on the market, though no company is to be formed for the present. The needle is said to be made of the quill of a feather, chemically treated. One can be used for ten selections, and soft, medium and loud effects can be secured through the new needle. A special holder will be required for the new contrivance. These are to be manufactured by the Cincinnatians. The needle is in the shape of a spear.

There have been no further developments in the affairs of John Arnold. Nothing has been heard of Mr. Arnold by his former business associates.

The Milner Musical Co. has discarded its sheet music department, and in about a week the Victrola section is to be enlarged. The latter work has been given in charge of Willis H. Strief. Manager Stotler expects to do considerable newspaper advertising very shortly.

Manager Whelen, of the Columbia Graphophone Co., expressed no dissatisfaction over the outcome of the month's business. He said: "During the first part of the month business was certainly on the 'boom,' but toward the latter part it sort of fell off, that is, as far as machines were concerned, but the record business held its own to the end. We have found it difficult to get in some of the larger types of machines from the factory, owing to the large demands, which the factory has been unable to supply. We are looking forward to a greater business as the summer season opens up, when the demand is great for machines and records for camping purposes. The 'Tango Outfit' has been greatly in demand, and inasmuch as it looks like the 'dance craze' is a permanent feature, machines and records will be more than ever in demand this summer."

Speaking of business in the outside territory, Mr. Whelen said: "We have closed with a large number of new dealers during the past month, all big accounts, and business seems to be good throughout the entire territory."

Victor business at Aeolian Hall has been entirely satisfactory the past month. The last week was especially active and gives promise that it will continue so during the next month.

Record sales picked up, especially in the dance music, which fell off during the Lenten season.

One of the most pleasing features of the month's business at Aeolian Hall was the demand for higher priced Victrolas. Victrola XVI was a big seller and a number of \$200 cash sales went through.

The record stock is in much better shape now than for some time past. Good use is being made of the attractive record catalogs recently gotten out by the Victor Co., and the Aeolian Co. continues to use large space in the daily papers in its advertising of the Victrola and Victor records.

The Rudolph Wurlitzer Co. makes the following report:

"In reviewing the business of the last thirty days and comparing it with the corresponding period in 1913, a splendid increase was found. During two

A VALUABLE ACQUISITION

To the Talking Machine Establishment of W. D. Andrews, of Buffalo, Is Prince Lei Lani, a Musically Gifted Hawaiian.

(Special to The Talking Machine World.)

BUFFALO, N. Y., May 7.—In musical circles in this city, Prince Lei Lani, who is a native of Hawaii, has made quite a number of friends. It was in 1901 that he came to the United States, spending his first two years in Stanford University improving his voice, which already possessed all that natural sweet quality peculiar only to the native Hawaiian.

His first appearance in public was with the famous Royal Hawaiian Band, which toured the world and played before the principal royalties of Europe, the prince appearing at each performance as a tenor soloist and a member of the Hawaiian octet.

During the great success of the "Bird of Paradise" the prince took a prominent part for two seasons as a member of the Hawaiian quintet. At the close of the season, in the spring of 1913, two of the number were killed in an automobile



Prince Lei Lani.

weeks of this period the record trade was rather light owing to unfavorable weather conditions, but taken as a whole the results were most satisfactory.

"The dance records continue to hold the interest of the public, and instead of showing a decrease the records are showing an increased sale, probably on account of larger shipments arriving, and a correspondingly more complete stock.

"We look forward to the summer without any misgivings as to trade conditions, and are already considering ways and means of handling the tremendous fall business which will surely result from the favorable conditions which now exist.

On May 13 Mr. and Mrs. Castle will give a performance in this city, and at this writing (May 4) the greatest interest is being shown in this event by Victrola owners, and the various demonstrating rooms are devoted almost entirely to demonstrating the new dance records.

"That the impression made upon the trade by this fad will have far-reaching results is beyond question, and there is no doubt when the dance craze dies out, if it does, the versatile Victrola will be no less an attraction in the homes where the dance craze has placed it."

accident near Boston. He has played the Orpheum circuit—also the Sullivan & Considine circuit. He was engaged at the Winter Garden for ten weeks during the late season of 1913 and scored quite a measure of success.

Prince Lei Lani, or E. K. Rose, as he is known off the stage, has a phenomenal voice. He sings with perfect ease tenor, baritone or soprano, and has a range of four octaves. During his appearance in Philadelphia in April, 1913, his ability attracted the attention of the Victor Talking Machine Co., which made Mr. Rose and his associates a flattering offer to appear at the laboratory and sing for the Victrola. These records were a success and have had a wonderful sale among all music lovers.

After the death of Mr. Rose's associates he decided to quit the stage and locate permanently. He selected Buffalo as the most desirable city. Since locating here last October Mr. Rose has appeared in many churches and clubs. His different voices, and several changes of costumes, enable him to give a full evening's entertainment. He has also had many out-of-town engagements in Western New York, Pennsylvania and Ohio.

Mr. Rose is permanently connected with the Victrola department of W. D. Andrews, 632-634 Main street, where he daily demonstrates his records to visitors.

MEDIUM IS IMPORTANT.

A drop of ink can still make millions think. But it has to be turned into live-wire language and printed in the right kind of paper to do it.

The DITSON Pledge

Is to see that our clientele has a better service than ever—setting a new standard in Victor jobbing deliveries. The demands of alert Victor dealers—the kind that grow—are many and varied, and we furnish the "first-aid" in every instance.

We believe this year's Victor business will be of tremendous proportions, and it will pay you to have

The Fastest Victor Service

which is a requisite in this hustling age. We possess the largest stocks, the best organization and most up-to-date equipment in the Eastern half of the country.

This covers Victor machines, records and supplies of every kind, not to mention cabinets, needles and trade-marked accessories.

Will you let us tell you more about Ditson co-operation? A postal gets this information!

OLIVER DITSON CO., Boston, Mass.



Whatever business the Columbia "Favorite" at \$50 is too expensive to meet, can certainly be met by the Columbia "Jewel" at \$35. You make a good profit on either and satisfy your customer in the bargain.



(Write for "Music Money," a book "full of meat" for those dealers interested in quick and frequent turnover of capital.)

Columbia Graphophone Company
Woolworth Building, New York

PRICE CUTTING KILLING THE TRADE IN ITALY.

Interesting Review of Talking Machine Situation in Italy by F. Passadoro, General Manager of Columbia Co.'s Italian Business—Price-Cutting Discouraging Legitimate Dealers—Horn Machines in Great Favor in That Country—Branch in Rome.

"The most serious draw-back to the development of the talking machine business in Italy is the terrific price cutting which is indulged in by the great majority of dealers in the country," said F. Passadoro, general manager of the Columbia Graphophone Co.'s Italian business, with headquarters at Milan, Italy. Mr. Passadoro sailed for Europe May 9th, on the steamer "Olympic," after a three week's stay in this country, during which he spent considerable time at the company's factories in Bridgeport, Conn. Mr. Passadoro has been connected with the talking machine industry for more than a score of years and is well acquainted with every detail of talking machine merchandising.

"As a result of this pernicious price-cutting," continued Mr. Passadoro, "we are losing many of our best types of dealers who prefer to place their investments in other lines of business, where they need not indulge in price-cutting wars and continually lose money. Price-cutting is the sole reason for the Italian talking machine dealer's failure to show any profits in his business. There are very few dealers, indeed, in our country who are making any money out of their business, and all because of their failure to maintain fixed prices on their products. They have the market and they have the product, but their lack of business foresight is driving many of them to ruin or out of the talking machine business.

"We are doing our utmost to convince the dealers that the one-price method of merchandising machines and records is their only salvation, if they wish to show a profit at the end of their year's work. We are handicapped, however, by the fact that we cannot compel the dealers by law to maintain a fixed price on any of our products. We have no association, and there is no concerted action in this direction, but at the present time several of the larger and more responsible companies, including ourselves, have in mind a co-operative plan whereby we can present the one-price doctrine to the dealer in an impressive and convincing way which may have the desired effect. There are only about 450 dealers in the entire country of Italy as a result of the continual kniving of prices, and many of the more successful of these merchants will retire from business in the near future, if conditions do not improve.

"Notwithstanding these handicaps, however, we closed in 1913 a very satisfactory year, and showed 40 per cent. increase over 1912 business. This increase was doubly gratifying in view of the general industrial depression of 1913, and the scarcity of money. With all the vast business that we and the other companies have closed in the past, we have just begun to scratch the surface of the talking machine possibilities in Italy. Our country is industrially improving steadily and consistently, and with this improvement of business

conditions, the field for talking machine development will increase in proportion.

"Italy, as is well known throughout the world, is an intensely musical country. Its inhabitants love and appreciate the better class of music, and this is well evidenced by the fact that the great majority of our record business consists of grand opera and vocal selections. It is a peculiar feature of our record business that we sell practically the same selections year after year. For 20 years I have known a large number of records that maintain a high average of annual sales, and will probably never lose the affection of the public. We differ radically from the American music-loving public, for with us there are no selections that score 'hits' one month and are practically 'dead' the next. The Italian talking machine dealer is, therefore, never in the position of having considerable dead stock on his hands, as his records sell year in and year out. This was illustrated when we cleaned out our cylinder record stock several years since; for, out of a total of more than 70,000 records, there were only 60 records dead stock, and these were all of one selection.

"Hornless machines are just beginning to make

LIVELY BUSINESS IN BUFFALO.

Prominent Makes of Machines in Strong Demand in That City According to Reports from Dealers—All Makes Popular.

(Special to The Talking Machine World)

BUFFALO, N. Y., May 2.—The advent of modern dances into the talking machine world has enlivened the trade considerably here in the last few weeks, according to reports of managers of the various stores. There has never been such a rush for dance records as has prevailed during the last few weeks, it is said, and there promises to be a bigger trade than ever this year.

The Victrolas are said to be selling rapidly and establishing records for sales. W. J. Bruehl, manager of the Neal, Clark & Neal Co., talking machine department, declared the Victrola and the Victor machines are at this time witnessing the biggest and most successful sales in their history.

The Columbia is also establishing records for sales and endorsements. The Buffalo branch of the Columbia Co. reports a most remarkable sales record during the past month. According to the manager of the store the Columbia branch in Buffalo has never before done such a good and steady business.

The Edison machines are also in the limelight and are doing better than holding their own. The Loud Piano Co., which handles this line, is elated over the sales during the past month. "Going good" is the way Mr. Loud put it.

some impression in Italy, although this impression is not yet of any particular depth. Personally I believe that the horn machine will never die in Italy, as it is firmly entrenched with the musical public. There is a certain form of reproduction possible with the horn machine and not with the hornless that is thoroughly appreciated by the Italian public, who believe the ideal machine is one that is equipped with a wooden horn.

"Over 80 per cent. of our business is closed with the poorer classes of people in our country. The laboring folk are passionately fond of good music, and the talking machine offers them the cheapest and best possible solution to gratify this love for music. The favorite method of merchandising machines and records in Italy is by means of the special outfits. These outfits, which consist of a machine, records and needles, are offered at various prices, and the most popular one at the present time is the outfit which retails at \$29. This outfit consists of a \$15 machine, \$14 worth of records and 300 needles, and is meeting with a ready sale throughout Italy.

"We have established dealers throughout the country, and in addition maintain a large distributing branch at Rome, with our executive offices at Milan. We also have a recording plant at the latter city which is kept busy all the year round. The outlook for this year is very bright, and I see no reason why our business in 1914 should not show a greater increase over 1913 than the 40 per cent. gain that we registered last year."

H. A. Yerkes, manager of the wholesale department of the Columbia Co., returned to his desk last week after a short trip through New England. Mr. Yerkes was well pleased with general conditions in this territory



Write today for our new catalogue giving you rock bottom prices of our specialties.

Springs for any kind of Talking Machines

No doubt you will find it interesting.



EMIL RIEDEL

Sächsische Sägen- u. Federstahlwaren-Fabrik.

Chemnitz-Gablenz, P. O. Box 10, Germany

The **TALKING**
For the makers & sellers of talking machines
MACHINE
WORLD

EDWARD LYMAN BILL, - - - Editor and Proprietor.

J. B. SPILLANE, Managing Editor.

Trade Representatives: GLAD. HENDERSON, C. CHACE, L. E. BOWERS, B. BRITAIN WILSON, A. J. NICKLIN, AUGUST J. TIMPE, L. M. ROBINSON.

Boston: JOHN H. WILSON, 324 Washington Street.
 Chicago Office: E. P. VAN HARLINGEN, Consumers' Building, 220 South State Street.
 HENRY S. KINGWILL, Associate. Telephone, Wabash 5774.

Philadelphia: R. W. KAUFFMAN. Minneapolis and St. Paul: ADOLF EDSTEN.
 San Francisco: S. H. GRAY, 88 First St. Cleveland: G. F. PRESCOTT.
 St. Louis: CLYDE JENNINGS. Cincinnati: JACOB W. WALTER.
 London, Eng., Office: 2 Gresham Buildings, Basinghall St. W. LIONEL STURDY, Manager.
 Representatives for Germany and Austria: VERLAG NEU SINIG, Berlin C. 19, Ross-Strasse 6,
 Germany. GEO. ROTHGIESSER, Director.

Published the 15th of every month at 373 Fourth Ave., New York.

SUBSCRIPTION (including postage), United States, Mexico, \$1.00 per Year; Canada, \$1.25; all other countries, \$1.75.

ADVERTISEMENTS: \$3.00 per inch, single column, per insertion. On quarterly or yearly contracts a special discount is allowed. Advertising pages, \$100.00.

REMITTANCES: should be made payable to Edward Lyman Bill by check or Post Office Money Order.

NOTICE TO ADVERTISERS.—Advertising copy should reach this office by the first of each month. By following this rule clients will greatly facilitate work at the publication headquarters.

Long Distance Telephones—Numbers 5982-5983 Madison Sq.
 Cable Address: "Elbill," New York.

NEW YORK, MAY 15, 1914

THERE are a number of timid Americans who seem to think that the strained relations now existing between Mexico and the United States will develop to such a point that a long and expensive war will result therefrom which will have a very depressing effect upon the business interests of the country.

Hardly true, and there is no use of borrowing trouble as to what the future may develop. As a matter of fact, war is not pleasant to contemplate from any viewpoint, but it has never meant immediate depression, particularly when a country has such resources as is possessed by the United States.

Far from having a depressing effect upon business, war, if it comes, will have a decidedly enlivening effect. The men who are hanging back to-day will then join with the President and will support him in whatever he does.

As a matter of fact, no matter how much we may criticize the treatment of the Mexican subject up to the present time, the fact remains that we, as a country, will have to face whatever develops. We will have to stand back of the President.

Many of us who have become personally acquainted with conditions in Mexico through travel, have been unable to understand how the Government at Washington should have been so misinformed as to the actual conditions, but there is no use to discuss that at the present time.

We are facing the present and will have to stand by future developments, be they what they may.

IF war comes, however, it will have a stimulating effect upon many lines of trade, and such a war as would be carried on in Mexico would be conducted without serious interference with the business affairs of this country, and, in our opinion, there is no reason to borrow trouble concerning the effects of war upon the trade of the nation.

If it comes some of us will suffer, but the country as a whole will hardly feel the shock, so let us go ahead and make our plans and forget about war troubles until they come. It will then be quite time enough to figure developments.

In the meanwhile, the spring promises to be active in many lines of trade, and the talking machine men should see to it that they get their full share of the business that is going around.

Business is not going to come easily—it rarely ever did, for that matter. It requires good, progressive work all the while.

It would seem to us that at such times as this, the collection

end of the business should be watched in a most careful manner, also the costs of doing business.

The causes of many business failures can be traced directly to ignorance of the actual cost of conducting a retail establishment, and the result of not knowing how to run your business spells business disaster at some time. The length of time is dependent entirely upon the resources of the house, but the final result is bound to be the same in the end, and the man who does not realize this will come to financial grief.

IT is, therefore, of the utmost importance that every business man should know the actual cost of conducting business and not fool himself with the idea that because he is doing what appears to be a fairly satisfactory bulk trade that he is making money. He may not be, because it is the net results that count. If he has permitted his expenses to grow to such an extent that he is not keeping track of his outlay he may face failure.

Probably 30 per cent. of the business failures of the country may be charged against ignorance and incompetence—then, of course, the granting of unwise credits.

The retailer oftentimes in his haste to get out goods does not ascertain as to the standing and ability of his customers to meet their deferred payments. A talking machine is very poorly sold to a party who is not financially able to own a machine, and, yet, if the character of people is thoroughly ascertained, there is no question but that talking machine leases constitute the finest kind of trade property, but in the talking machine trade there are a good many young men who do not safeguard their business interests in the manner in which they should. They should start in right, and most inexperienced young men think that the managing end of the business is quite easy. Some of them think it is no trouble at all, provided a man has a moderate amount of capital. It figures out finely in theory and looks very simple to take so many dollars worth of merchandise and sell that merchandise for a good liberal percentage of increase over its original cost, then figure the difference as clear profit!

Easy, indeed, in theory but it does not work out that way.

ANY man, however, can add to his store of knowledge if he carefully analyzes the conditions which surround his business operations day by day. Do not let them get away from you.

Many a good man, with splendid business possibilities, has permitted himself to drift out of contact with his business affairs, and the result has been failure which could have been easily avoided had he kept in touch with the business situation.

There is nothing easier than to permit business to get away from you, and there is nothing more expensive than to permit it to stay out of touch.

Some of the greatest business men of the country have a most intimate knowledge of all the interior workings of their great enterprises. They do not worry themselves much with details because they have men employed who supply them with reports, but they have a system so perfect that they are enabled, through reports from every department, to have at all times the closest contact with the workings of the great machinery which they are directing. There is where the enjoyment of conducting an enterprise comes in, is directing it and feeling that your thoughts, your energies, your inspirations, are directing a piece of machinery which is accomplishing greater results all the while, and the results—the tangible results—illustrated by the net profits—are what interest business men.

It is easy to figure out profits on paper, but the next thing is to translate them into bank balances. That is the real thing.

THE circular trade letter is not growing in favor with national advertisers. A good many who have tried the letter plan have not found it successful. One reason is that retailers are receiving too many circulars of various kinds to pay serious attention to any of them.

Much good brain matter is wasted in the preparation of attractive letter circulars which are supposed to whet the appetites of prospective customers, but they do not swallow this kind of bait with avidity.

When a man receives ten, twenty and sometimes fifty, circular

letters a day, it is but reasonable to suppose that he does not consider any of them seriously. A great portion of them reach the waste basket without even so much as having them scanned by the merchant to whom they are addressed.

The expense of this kind of advertising is tremendous when we consider the preparation of the circulars and the time spent in getting them ready to mail. The postage bills all mount up, and the result is that many who have tried this form of advertising are not satisfied with the results obtained.

Trade papers with a legitimate circulation receive careful attention from the same class of merchants who would cast the circular into the waste basket without glancing at it.

And why?

Because the trade paper represents an organized attention center and medium of publicity comparable to a clearing house or public market.

The merchant knows that there is a variety of information contained in the trade papers and a large portion of it is extremely valuable to him in his business, and he objects to being flooded with circulars, and incidentally the advertisers are beginning to find this system unsatisfactory.

WE know of some men who have sent as many as six circular letters to the same individual, and when they sent a representative to call upon him, he did not recall having received a communication from the house, and so this kind of literature did not even help the salesman; whereas the same money expended in a trade paper would have attracted attention. Proof of that is seen in the returns which advertisers receive from trade papers of reputation and standing.

The Talking Machine World in this respect occupies an unique position. It is the only paper reaching the talking machine trade, and it is read by thousands of people monthly who look upon it as the only medium from which to secure a fund of information obtainable from no other source.

We are in constant receipt of letters from subscribers who say they could not keep their business house in order without The World—that they would even pay \$10 a year for it rather than be without it.

We also are receiving constantly letters from advertisers who express themselves as pleased with the results obtained through advertising in its columns.

Talking machine jobbers do not use The World in the way which they should. It circulates among their local trade, and yet many of them do not patronize it through a false conception of the business situation.

Some figure that the manufacturers should do the advertising while they sit back and enjoy the results. That is the kind of policy which some of them adopt. Others—the most progressive—continue to use the columns of The World and they are getting results. They are going far ahead of their competitors, who, through their trade narrowing vision and lack of progressiveness fail to improve the avenues which lie open to them.

Here is an extract from a communication from a well-known

New York jobber, Silas E. Pearsall Co., who does not hesitate to credit The World with results:

"Emergency calls require special treatment and the shortage of records in the talking machine trade brought about a condition that made the Pearsall stock exceptionally valuable to the trade. There were several ways of reaching the people we desired to acquaint with the fine condition of our stock and we tried all of them. The way that brought best results was the way of The Talking Machine World. The terse advertisement in The World added a great many customers to our already large list and added them within two weeks after our advertisement was placed in the February number."

That is a communication from a business house which has tried the business building powers of The World with excellent results.

Others can secure the same results, for The World is a paper for everybody in the talking machine trade.

THE last issue of Good Storekeeping, commenting upon trade papers as a class, takes occasion to single out The World as a wonderful publication. It says, editorially:

"There is not a branch of modern business but has one or more publications devoted to it. It is difficult to understand how enough information can be procured to make all the papers interesting to their readers, especially in some cases where the field of discussion appears to be so limited. For instance, one would wonder where The Talking Machine World could possibly find enough material to fill its columns. Still Edward Lyman Bill, its publisher, makes this paper one of the most readable of the trade publications. How would the average editor like the job of getting out a sixty-page magazine every month on the single subject—the little talking machine?"

The constructive force of this publication is unquestioned and is not denied by the business builders of this industry.

IN the light of Governmental activity against restricting agreements in this country, the business practices of some other countries are most interesting. Consider this news from Uruguay:

The wholesale merchants of Montevideo have decided to enter into a ten-year mutual agreement, with liberty to extend it for another five years, to regulate trade operations. Control of the agreement is to be intrusted to a committee consisting of a bank manager and four importers, who will inflict a fine of \$2,000 for any infringement of the agreement. Some of the principal clauses of the agreement follow:

Sales are not to be effected on credits exceeding six months.

Goods sold must be invoiced in the same month, it being forbidden to deliver them in one month and date the invoice another.

A maximum of 6 per cent. discount to be allowed to purchasers paying for goods before the 15th of the month following the sale.

Payments made in the same month as the sale to be entitled to an extra discount of one-half of 1 per cent. Interest at 12 per cent. to be charged on any notes renewed.

Delivery of goods on consignment prohibited.

Beka Records

IN ALL LANGUAGES OF THE WORLD

High grade selections in

German, English, Italian, Spanish, Portuguese, French, Swedish, Slavonic, Ruthenian, Danish, Norwegian, Russian, Polish, Hungarian, Bohemian, Rumanian, Tschechisch, Croatian, Servian, Hebrew, Turkish, Persian, Arabic, Chinese, Malay, Japanese and seventeen different Indian dialects.

The cheapest and best machine on the market for \$2.50 upward

BEKA-RECORD AKT. GES., Berlin, S. O. 36 (Germany)

CATALOGUE IN FOUR LANGUAGES SENT FREE ON REQUEST



We are top, bottom, and both sides of the talking machine situation in a very sightly list of cities in these United States right now and getting a sure grip *everywhere else.*



(Write for "Music Money," a book "full of meat" for those dealers interested in quick and frequent turnover of capital.)

**Columbia Graphophone Company
Woolworth Building, New York**

IDENTITY OF WRITER REVEALED.

Under the Nom de Plume "D. A. Esrom" Mrs. Theo. Morse Has Written a Great Number of Songs Which Have Won National Popularity Through the Phonograph.

For many years lovers of popular songs have enjoyed those written by an unknown writer named D. A. Esrom. The identity of this lyric writer remained a secret for a long time. The songs were almost invariably adapted to music by Theo. Morse, of New York, and published by



D. A. Esrom (Mrs. Theo. Morse).

him. It remained for a representative of the Thos. A. Edison, Inc., to discover the secret of D. A. Esrom's identity.

Mr. Morse had been asked repeatedly on this point, and one day he very blushingly acknowledged that D. A. Esrom was his wife. "You see," he explained, "my wife's name is Dolly A. Morse—Esrom is merely Morse spelled backwards."

Of course after this the secret was out, and Mrs. Morse speedily became known as one of the great women writers of popular songs in the United States. Although she has originated enumerable lyrics that are especially clever, still she does not

think that a professional career is the best for women, for as she puts it, she does the housework with her hands and composes the songs in her head at the same time.

A large number of Mrs. Morse's songs have been made for Edison records and are especially popular. Among those that all Edison owners will remember are the following: "In the Land of Plankity Plank," "Luella Lee," "Sweet Anna Marie," "The Village Band," "Another Rag," "Bobbin Up and Down," "Lizabeth Ann," "Love Me Like I Love You," "Lets Buzz," "Something's Going to Happen to You," "Way Back Home," "When You're Lonesome Don't Forget My Number," "When Uncle Joe Plays a Rag on His Old Banjo," "Whistling Jim," "Who's Going to Love You When I'm Gone," "You Need a Rag."

The following have been written by D. A. Esrom but are not on the records: "When You Sang the Rosary to Me," "Until You Say Goodbye," "Three Things I Love," "Call Around Any Old Time," "When We Were College Boys."

MASTERPHONE CAMPAIGN

Of National Advertising Is Bound to Help Dealers' Sales Most Materially.

The Masterphone Corporation, manufacturers of the popular Masterphone device for clarifying and amplifying the tone of records, moved this week from 187 Broadway to Suite 1921, 61 Broadway where it will have increased floor space for its rapidly growing business.

"We are now in the midst of a national advertising campaign that should produce numerous inquiries for talking machine dealers throughout the country," said an official of the company. "This campaign is being confined to the leading national magazines, and the copy we are using, though not very large in size, is designed to attract general attention and, what is more important, produce live inquiries. We are planning to issue in the near future numerous dealer helps in the nature of window and store displays that will be attractively arranged and certain to attract interest."

The Masterphone Corporation has just issued an interesting and informative folder which explains in detail the value and workings of this clarifying

and amplifying attachment for talking machines. This folder shows by the means of excellent illustrations the simplicity of the Masterphone and shows how the device is adjusted on fiber or steel needles. The merits of the Masterphone are set forth clearly and lucidly, and dealers can use this folder to excellent advantage.

THE DOME RECORD CASE.

This Cleverly Constructed Device Holds Twenty Records—Useful for Concert or Demonstration Purposes—Distributed by W. D. Andrews, of Buffalo.

W. D. Andrews, 632 Main street, Buffalo, N. Y., has closed arrangements whereby in the future the Dome Record Case will be distributed by him. This record case—illustration of which is shown elsewhere—holds 20 records, all accessible for instant use. The case swings open so that the repertoire is displayed, while a convenient index shows where each record is located.

The Dome Record Case is very valuable, because not only does it permit the safe keeping of records, but it is a case that permits one to carry a small stock of records for either demonstration or concert use. Furnished in two sizes, 10 and 12 inch, and Mr. Andrews is making a specialty of sending samples of these filled with records, as selected by the customer.

For instance, if a dealer has 20 records that he is in need of and wants a sample Dome Record Case, Mr. Andrews will send the entire thing to him at the regular wholesale prices, and in the matter of deliveries, this house has thirteen lines of railroads, five express companies and the best lines on the Great Lakes, so deliveries can be made very quickly.

WURLITZER CO. IN HAMILTON.

An entire room in the new quarters recently opened at 119 South street, Hamilton, O., by the Rudolph Wurlitzer Co., of Cincinnati, has been set apart for Victrolas. There will be also several booths for the trying out of Victor records, of which this agency has over 10,000.

READY REFERENCE OF GENERAL SUPPLIES

DEALERS

Send for our "Trial Proposition" on the Regina Hexaphone—the latest and best paying popular priced coin-operated instrument for use in public places.

THE REGINA CO.

211 Marbridge Bldg., 34th St. and Broadway, New York City
Manufacturers of Regina Music Boxes; Reginaphones;
Coin-operated Mandolin Orchestrons; Vacuum
Cleaners and other specialties.

Mermod & Co.

505 Fifth Avenue New York

Manufacturers of

Talking Machine Supplies

Motors—Sapphire Points

Diamond Points a Specialty

Keep Your Record Stock with

THE Gelse SYSTEM

Costs about \$2.00 for 250 records for 50 years
Send for 20-page catalog

**THE SYRACUSE WIRE WORKS,
SYRACUSE NEW YORK**

CO-OPERATION BETWEEN JOBBER AND DEALER NEEDED

So That the Latter May Be Afforded Every Opportunity to Make His Record Business as Profitable as His Territory and Stock Will Permit—Well-Considered Remarks by V. W. Moody, Sales Manager of New York Talking Machine Co. on This Subject.

With the continued shortage of records and with the dealers throughout the country complaining at the marked scarcity of many of the most popular records in the library, it has long been apparent that there should exist perfect co-operation between the jobber and the dealer in order that the latter may be afforded every opportunity to make his record business just as profitable as his territory and stock will permit.

As an example of this co-operation between jobber and dealer, a new idea introduced this month by V. W. Moody, sales manager of the New York Talking Machine Co., 81 Chambers street, New York, Victor distributor, is well worth careful attention. Mr. Moody has for many years made a detailed study of sales methods and stock systems and his extended knowledge of this important branch of the Victor business has been largely offered to dealers who were desirous of improving or increasing the efficiency of their sales policies and systems.

Mr. Moody's latest dealer help was concerned with the dealers' advance order blank for new Victor records for the month of May. This advance order sheet is a very important factor in the dealer's business, as adequate ordering of the newly issued records means the closing of many a record sale that is lost if the new records are not on hand. The manufacturers and jobbers are invariably in a position to fill all advance orders for the new records, while the supply of certain records is frequently exhausted before the dealer places his second order.

Realizing the importance of this advance order sheet, Mr. Moody went to considerable trouble and expense to prepare a special revision sheet which he purposed to use in connection with the dealers' May advance record order. This revision sheet contained three columns headed, "You Ordered

Originally," "Our Suggested Revision" and "Your Final Order." The names and numbers of the May records, together with a special approval space for the dealer, formed the balance of this sheet.

As soon as the New York Talking Machine Co. started to receive its dealers' May advance orders, Mr. Moody began active work on his co-operative plan, which consisted of taking the dealers' orders and averaging them in order to secure a general average for each record. Mr. Moody waited until over 60 per cent. of the company's dealers had sent in their orders and then made up his averages. Using these averages as a basis for revising the individual dealer's order and working out a standard of comparison for each dealer's order sheet, Mr. Moody was enabled to send each dealer a revision sheet that represented suggestions based on actual figures as averaged from the large number of May orders received.

The dealer therefore received a suggested revision for his advance orders that was worth far more than a personal opinion or belief, and which represented the combined average orders of his fellow Victor dealers. Accompanying this revision sheet was a short letter which explained to the dealer the purpose of the revision sheet, how the suggested figures were arrived at and requested that the dealer give the order blank his careful attention before placing his final order.

"The results achieved by this revision sheet were entirely satisfactory," said Mr. Moody in a chat with *The World*. "Over 75 per cent. of our dealers who received the sheets replied immediately, placing their final order in accord with our suggestions, the great majority O. King the suggested revision in its entirety and others making changes here and there. In many cases our suggested revision order did not exceed the dealer's

original order, while in other instances the total was quite in advance of the dealer's first order.

"Many of our dealers expressed their appreciation of our co-operation and thoughtfulness, remarking that they were glad to be afforded this opportunity of benefiting from the ideas of their associate dealers. From our own standpoint, the revision sheet idea was a gratifying success and, in accord with our dealers' request, we are planning to continue the plan with the June advance order sheets."

TO CONTINUE CYLINDER LINE.

C. H. Wilson Issues Emphatic Denial That Thomas A. Edison, Inc., Plans to Stop Manufacturing Cylinder Phonographs and Records—Arrangements for Future Indicate Policy of Company.

C. H. Wilson, vice-president and general manager of Thomas A. Edison, Inc., made the following interesting announcement this week:

"On several occasions we have been told that a rumor is abroad to the general effect that we intend ultimately to abandon the manufacture of Edison cylinder phonographs and records and that there will be a diminishment of our activity in respect to these products. We wish to deny this most emphatically.

"The confidence of this company in the continued demand for the Edison cylinder product is proven by the enormous investment we have made in recent months in the improvement of this line and the further expenditures that are now being made with the same purpose in view.

"We expect to push the sale of the Edison Blue Amberol records and the Edison Diamond Amberols with renewed vigor, and are at present investigating several new methods of sales exploitation in order to find those best suited to this product.

"Such methods as test out satisfactorily will be submitted to the trade in due time. We expect to make an unusually vigorous campaign—commencing during the coming season."

S. B. DAVEGA COMPANY

831 BROADWAY, NEW YORK CITY

Dealers' Specialties

WILL KEEP YOU BUSY
ALL SUMMER

WE JOB THE
FOLLOWING LINES:

Ingersoll Watches

Reach Sporting Goods

Thermos Bottles

Gillette Razors and Blades

Gem Jr. Razors and Blades

Rubberset Shaving Brushes

Roller Skates

Police Whistles

DEALER'S WALL CATALOGUE RACK



THE HANDIEST NECESSITY FOR
ALL TALKING MACHINE STORES

Plenty of room for all Domestic and Foreign Record Catalogues, Monthly Supplements, Machine Catalogues and all Folders.

MADE IN GOLDEN OAK FINISH

PRICE \$4.00 F.O.B. NEW YORK

DISTRIBUTORS OF

Victor Talking

Machines

Records

Supplies

Cabinets

And accessories of every description

Edison Cylinder
Phonographs

AND BLUE AMBEROL RECORDS

HOW THE PATHESCOPE APPEALS.

Interesting Experience That Throws Light on the Value and Use of This Home Moving Picture Machine—W. A. Condon Joins Pathéscope Interests—Will Visit "Talker" Dealers.

Willard B. Cook, manager of the Pathéscope salon, 27 West Forty-second street, New York, relates the following incident with reference to the ease with which these home moving picture machines are selling through the country:

"A Brookline, Mass., gentleman happened to notice a Pathéscope advertisement in one of the newspapers, sent for a catalog, and then wrote to inquire if a person, who had never seen one of the instruments, could set it up and operate it without previous instructions. Upon our assuring him that the printed instructions were adequate, he promptly forwarded a check for \$250 for the most expensive model of the cabinet machine.

"Nearly a week elapsed and I was beginning to feel a little uneasy for I had not heard from the gentleman since he sent in his check, when one morning a smiling caller remarked, 'I am Mr. _____, of Brookline.

My wife and I enjoy the instrument immensely, but I haven't had time yet to read the instructions for operation; in fact, I didn't seem to need any.' Before leaving our salon, this gentleman had purchased a number of reels and had taken a year's subscription to the film exchange.

"If our instruments can be bought from the catalog description, and give perfect satisfaction, there is certainly a splendid field for the live-

wire talking machine dealer with the Pathéscope. We have received territory requests from a number of dealers who realize that the Pathéscope and the talking machine form the ideal home entertainment, and all our dealers are enthusiastic over the possibilities of the Pathéscope field." Mr. Cook is at present abroad, arranging for prompt shipments of instruments to meet the demand in this country.

W. A. Condon, well known in the talking machine trade, has joined the Pathéscope as travel-

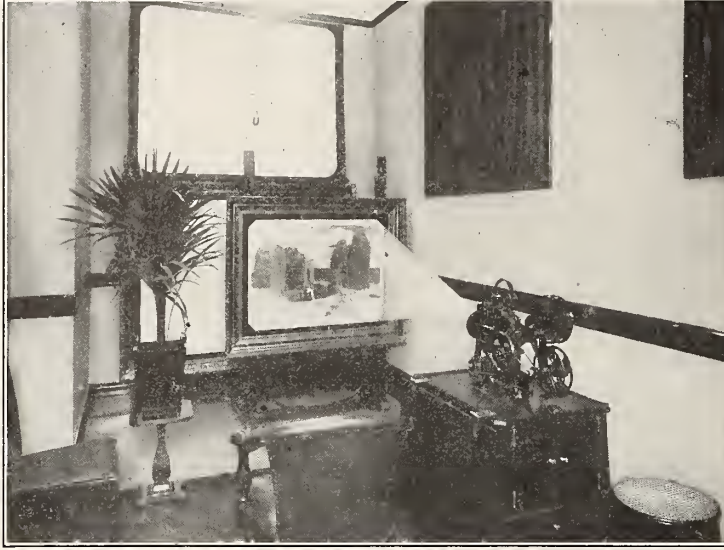

A Corner in the Pathéscope Salon, Aeolian Hall.

ing ambassador, and will concentrate on the development of the Pathéscope trade with talking machine dealers. Mr. Condon's lengthy experience in this field well equips him to achieve a marked success in his new connection.

When angry, think twice before speaking. That will give you time to call him a more resounding name.

BUSY MONTH IN BALTIMORE.

Reports from Leading Houses Most Encouraging—With All Concerns April Was Busy Month—More Room for E. F. Droop & Sons.

(Special to The Talking Machine World.)

BALTIMORE, MD., May 5.—Unlike the piano dealers, those engaged in the talking machine business in this section are making most encouraging reports concerning business conditions for April. The sum of all these reports would indicate that April was right up with the other months and that the dealers have every reason to look for just as good results during May.

Joseph Fink, of the Fink Talking Machine Co., declares that April was the largest month for sales since December as far as his firm is concerned. This firm handles both the Victor and Columbia lines.

E. F. Droop & Sons Co. has acquired the property in the rear of its present building, which it has been after for some time. The firm will make some elaborate improvements and will devote the additional space to the wholesale end of the business for receiving and distributing goods. Manager W. C. Roberts reports a big April with the Victor and Columbia lines, and is looking for May to keep up the good work.

The Kunkel Piano Co., handling the Victor and Edison lines, has a pretty window display in the shape of a music room in which it shows off to advantage the various styles of machines and records of the two lines.

S. A. Dennison, manager of the local branch of the Columbia Graphophone Co., has his monthly report posted conspicuously on his trustworthy slate, which says that April receipts were the largest ever taken in at the Baltimore store.. This gives some idea of what was done during April in the Columbia line. Mr. Dennison looks for as good results during May.

H. R. Eisenbrandt Sons, 306 and 308 North Howard street, one of the original Victor distributors, report a good month with the Victor line and records during April.

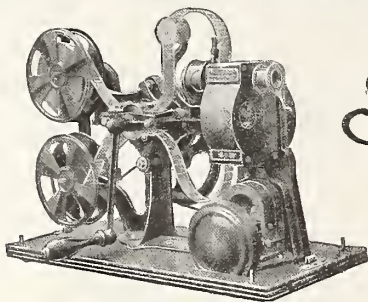

The first Safe, Simple and Perfect Home Motion Picture Machine

AN opportunity for you to double the volume of your business from your present clientele.

Why?—Because—

Phonographs and Pathéscopes Give the Ideal Combination of Music and Movies

—and you, as a Talking-Machine Dealer, are the logical distributor of the Home Motion Picture Machine.

The first Dealers to recognize the business possibilities offered by the Pathéscope will reap the largest profits. The field is ready and waiting.

Be the leader—the first Dealer in your neighborhood to show and sell Pathéscopes.

This space does not permit a full description of the machine nor the scope of your opportunity, but a postal will bring our catalogue and further data.

For Demonstrations or Catalogue address:

PATHÉSCOPE

Department W.

AEOLIAN HALL, NEW YORK.

Agencies:

414 Crozer Bldg., Philadelphia.

622 Kittredge Bldg., Denver.

1306 Marquette Bldg., Chicago.

Responsible representation desired elsewhere.



Mounted in the beautiful Mahogany or Quartered Oak Cabinet, the Pathéscope is an ornament to any Home, where it at once becomes the Companion Entertainer to the Talking Machine.



The increasing Columbia dance record business you are missing ought to make you nervous.



(Write for "Music Money," a book "full of meat" for those dealers interested in quick and frequent turnover of capital.)

Columbia Graphophone Company
Woolworth Building, New York

DETROIT MAKES CHEERY BUSINESS REPORT.

New Stores of the Columbia Co., and the J. L. Hudson Co. Will Be Ready for Christmas Trade—Business as a Whole Most Excellent—Dancing Craze Still Helping Record Sales—Many New Suburban Accounts Being Added—News of the Month.

(Special to The Talking Machine World.)

DETROIT, MICH., May 7.—The Victrola and Columbia lines will be at home in a swell and commodious new salesroom when the next Christmas season rolls around. The music trades department of the J. L. Hudson Co., which handles both lines, will occupy three floors of the new building, which is to replace the present old structure and two adjoining ones on Woodward avenue, and it is likely that one entire floor will be devoted to talking machines. This will give them a space of 84 feet front by 100 feet deep,

stories of hard times that certain interested politicians have sent broadcast over the country in an effort to create a belief that Detroit was about to go into bankruptcy.

Business Better Than Last Year.

Business also is better than last year, as much as 30 or 40 per cent. with some houses. The effects of Lent and Easter have passed, and the business has settled down for its usual excellent summer run. Detroit always is an exceedingly good point for talking machine business in summer time, owing to the many ways these prod-



Show Window of J. L. Hudson Co. Displaying Victrola.

and will constitute the largest talking machine department in the city.

Besides this, the talkers will have a magnificent show window on the street floor in which to advertise themselves to the passing throng. It will be a finer window than the present one, and the real significance of that statement can be judged by the photographic view of the existing one which is reproduced herewith. The feminine "salesman" in the picture is wax, but is so perfect and so elegantly appareled, and the "corner of the music room" is so elegantly laid out that the window has a big audience constantly. The machine in the window at the time the photo was taken, was a Victrola. Sometimes a Columbia grand is there.

Collections Are Excellent.

The most pleasing feature of the talking machine trade in Detroit just now is the excellence of the collections. They are better than last year, and with some houses, better than ever before, thus giving the direct retort courteous to the

ucts are used for outdoor entertainments—on boats, yachts, in camps and in summer resort cottages. Lent generally manages to crimp business a bit, because buying a talking machine is one of the easiest things to forego. Easter crimps it a little because the money is needed for new hats and other personal decorations. With these two periods by, sales always pick up rapidly.

It is likely that the agreement of the dealers to charge interest on time sales made last year has a good deal to do with the good collections, though the fact that thousands of men have resumed work on summer occupations after several months' lay-off helps. If there have been any lapses from the interest agreement, they are not specifically known. The agreement has a splendid effect in getting large first payments and in inducing prompt payments thereafter.

Keeping Track of Suburban Business.

The Columbia branch store here makes it a point to keep the new suburban business districts well covered. Every year Detroit builds on its

outskirts three or four new cities as large as good sized up-to-date municipalities. These suburbs have one or more lively business streets, and City Sales Manager S. E. Lind, of the Columbia, places an agency in all spots where the prospects for trade look good to him. He has several big prospects in the city, some down town, in view at present, but will make no announcements until contracts are closed. A new account has been opened in Delray, a down-river suburb.

Dancing Craze Still Prevalent.

Detroit is particularly ripe for the books issued by the Victor Co. and the Columbia Co. giving instruction in the steps and figures of all the new dances. While the sale of talking machines for the sole purpose of furnishing music for home dancing has been large for several months, this new aid to the terpsichorean art has given it an added impetus. In Detroit there is a fashion nowadays of building houses with large living rooms, thirty or more feet long, so that there is plenty of room in them for dancing, for small parties. With such a layout, a big talking machine in a corner furnishes all that is needed for a "swell time."

New Accounts Being Added.

Out in the State new accounts are being added constantly by the Detroit representatives of all companies. Agencies are placed in towns as small as 500 population. Of course, the business of the town is not much, but the sales to farmers in the surrounding territory are well worth while. The dealers in cities up to 2,500 population sell to farmers as much as they do to the residents of the cities.

Grinnell Bros., Victor jobbers, have an effective plan for inducing competition among salesmen, and thereby getting good results in the matter of terms as well as in volume of sales. Each salesman has an efficiency card. It shows the character of all sales, the size of first payments, the size of instalments, whether the customer keeps up his payment and other details of every sale made.

The firm is thus able to know to a dollar whether the salesman's work is profitable, and the salesmen know "who's ahead" and vie with each other for the supremacy.

As an example of the results of this system in the last fiscal year of the company, the leading salesman averaged in volume of first payments 40 per cent. of the value of the machines he sold. Several of them exceeded 25 per cent., and the lowest of all was 17 per cent.

I. DAVEGA, Jr.

125 WEST 125th STREET, NEW YORK

Victor Distributor

PROMPT AND ACCURATE SERVICE

DEALERS: Write for our Victor Pennant. Sent with our compliments.

THE TRADE IN BOSTON AND NEW ENGLAND

JOHN H. WILSON, MANAGER, 324 WASHINGTON STREET, BOSTON, MASS.

(Special to The Talking Machine World.)

BOSTON, MASS., May 11.—The feature in the local talking machine business is the advertising "stunt," really a gigantic undertaking, wherein the Boston American and the Columbia Graphophone Co. co-operated. It took several weeks to work out the details of this large scheme, and the American every day, for a week in advance, gave its readers some hint of what was to be expected on the following Sunday, which was May 3. On that day readers must have been aghast when they opened their American and found more than three pages devoted to the dance records of the Columbia. It is the latest dances that are featured and liberal space is given to a lesson on how to dance the one-step and several illustrations tell even more graphically how to perform it. In the course of the advertisement there is a coupon, which, with 25 cents, procures a Columbia disc, on one side of which is the music for the one-step, preceded, however, by some verbal directions how to start out. All the Columbia distributors throughout New England were well supplied in advance with this record, and promptly on Monday morning a big demand was made at all points, and several times the call came near exceeding the supply.

This is the first of a series that is to keep running for four successive weeks and there will, therefore, be three more. In the plan of advertising practically all of the Columbia distributors took space, so that in the sum total there was a large representation of advertisers. G. Hepburn Wilson, who supervises the dance records for the Columbia, was on the scene early, as he had a part in the general plan; and Arthur Erisman, the Boston manager of the Columbia, worked early and late superintending the arrangement of the advertisements and keeping a general oversight over the work. Naturally, he is getting his full mead of praise for the enormous amount of work he put into the scheme.

Arthur W. Chamberlain Resigns.

One of the surprising pieces of news of the month in talking machine circles, was the resignation of Arthur W. Chamberlain as manager of the wholesale department of Eastern Talking Machine Co. Mr. Chamberlain has hosts of friends in the business and his associates in the Eastern Co. were more than sorry to have him sever his connection, which had been very pleasant. It is understood that Mr. Chamberlain has certain plans

in view which have been maturing for some time. Next month your correspondent hopes to be able to make some definite announcement of Mr. Chamberlain's plans.

Mr. and Mrs. Vernon Castle in Dances.

Many talking machine men were numbered among the large audiences that packed the Boston Opera House on the afternoon and evening of April 27, when Mr. and Mrs. Vernon Castle gave two exhibitions of their famous dances. Dealers say that since they were in town, there is scarcely a home with a talking machine that has not gone fairly wild over the new dances and their accompanying music.

Move Will Eventually Help.

Work on the demolition of the neighboring building to the Columbia quarters in Tremont street is going on rapidly, and it will only be a short time now before it will be razed to the ground. Then will begin the work of rearing the side walls for the Columbia, and, if there is more or less inconvenience in the handling of goods inside the warerooms, the condition is easily offset by the thought of the unusual facilities that will be enjoyed when the new street is finally laid out, giving the Columbia such unequaled opportunities for advertising itself and its goods.

Working in Wholesale End.

James McDonald, who was one of the shining lights in the retail department of the Columbia Co., is now working in the wholesale end of the business. He is assisting Norman Mason, who has been making a great success since he devoted his attention to the outside end of the Columbia interests. Another transfer is that of George Krum-scheid, who also is now working in the wholesale department.

Busy Times with Oliver Ditson Co.

All the office staff working in happy conjunction with Manager Henry Winkelman, of the Victor department of the Oliver Ditson Co., are finding business more than good these days. Since the installation of the new sound-proof booths, the increased facilities are proving just what the company needed to properly cope with the increasing demand for goods.

Pleased with Visit to Victor Factory.

Billy Fitzgerald, Mark Reed and Mr. Splaine came back from the Victor laboratories with a sounder knowledge of the intricacies of the manufacture of records than they ever before possessed. Incidentally, they had a jolly good time, and their

three days' holiday put them in good shape to handle the business of the Eastern Co.

Business and Salesmanship.

The Columbia Business Building Club held an enthusiastic meeting on one of the last evenings of April, and there was a spirited talk on business and salesmanship. The mechanical construction of the Columbia machines was gone into quite thoroughly, and the Columbia staff was able to extract much useful knowledge out of the meeting.

Sylvester Makes Change.

Roy Sylvester, formerly on the floor of the Columbia Phonograph Co., has severed his relation with that house and now is with the Atherton Furniture Co., at Worcester, where he is in charge of that large concern's talking machine department.

Larger Quarters for Pardee-Ellenberger Co.

So large has the Edison business of the Pardee-Ellenberger Co. become, that Manager Silliman has been forced to look about for larger quarters. These have been found at 26 Oliver street, not a great way from the present location at 66 Battery-march street. The new quarters, which, it is hoped, will be fully occupied by June 1, comprise two floors of 10,000 square feet of space. Manager Silliman is planning to so move as to interfere with business as little as possible. The readers of this department will learn more about the new Edison quarters in next month's issue.

Expansion of Victor Business.

The Victor department of the C. C. Harvey Co., which has taken on a new lease of life since Francis White has assumed management, has been moved to larger and more convenient quarters on an upper floor. The department has been located in the basement, and it was expected that the move would have been made some time ago, but the quarters were not ready. The rooms are reached by excellent elevator service.

Exhibition of Modern Dances at Steinert's.

To the accompaniment in part of the music of a Victrola, the M. Steinert & Sons Co. entertained its friends with an exhibition of some of the modern dances a short time ago in Steinert Hall. The admission was by invitation and the hall was crowded with a fine audience. The exhibition was a success in every particular.

New Rosen Store.

Although Henry Rosen has not placed a permanent manager in charge of the new store at 246 Huntington avenue, he is already doing business there and has contracted with the Victor Co. for

IT IS the real music feature of the new Edison Diamond Disc Phonograph that has sent it flying into the homes and hearts of music loving people—of whom there are many more who haven't purchased an Edison. This is the class that will give you a profit in your own city if you will be an Edison man.

We'll back you up with the P-E Service, a composite organization of men, brains, money and action, instituted primarily to give you a co-operative service that is of business building character.

Ask us today for the entire story.

Real Music
At Last

The Pardee-Ellenberger Co.

Boston, Mass.

New Haven, Conn.

THE TRADE IN BOSTON AND NEW ENGLAND

JOHN H. WILSON, MANAGER, 324 WASHINGTON STREET, BOSTON, MASS.

a large stock of goods. Mr. Rosen, judging by the many customers that drop into the place, made no mistake when he established this new store.

H. A. Yerkes a Visitor.

H. A. Yerkes, the wholesale manager for the Columbia Co., was in town yesterday for a short visit. He had been on a tour of the New England agencies and before coming to Boston had made several stops throughout Connecticut and Rhode Island, and, after leaving Boston, he was on his way to points in Northern New England. Mr. Yerkes expressed himself as well satisfied with the trend of business, and especially enthusiastic was he over the way the new dance records are going.

Walter Van Brunt Welcomed.

Walter Van Brunt, who was playing a good engagement as he always does at Keith's Theatre a short while ago, was a frequent visitor to the quarters of the Eastern Co., which is only a few doors away from Keith's. The boys are always glad to welcome this excellent entertainer.

Columbias for Brookline Playground.

Manager Erisman tells your correspondent that ten Columbias have been ordered for the Brookline playground, and will be put into use as soon as the weather will allow the children getting more out of doors.

To Entertain the "Jackies."

When the battleship "Georgia" steamed away from the Charlestown Navy Yard the other day for the Mexican coast, it was well equipped with musical instruments, and among other things it had a fine talking machine with plenty of records. Wonder who can guess who furnished the equipment, and did it well too?

ADVISES SALESMEN NOT TO "KNOCK"

Buyers Inclined to Lose Faith in Man Who Knocks Former Line of Goods.

"Knocking" a line on the part of salesmen after they have changed positions was heartily condemned this week by a buyer for one of the big local stores, said the New York Times. "I always lose faith in a man who 'knocks' his former line after he makes a change," he said, "for I can never escape the thought that he was selling me those 'rotten' goods before he made the change. If the goods really were what he said of them, it shows me that the salesman has been trying to stick me; if they were not, how can I believe him when he commends his new line? Many a salesman who has been selling me for years has changed his base and 'knocked' his old line with the idea of selling me the new. What he has succeeded in doing, however, has been to lose my trade entirely."

FRATERNAL BODIES AS PROSPECTS.

Recording of Music of Various Organizations Adds Interest to Machine Outfits for Meeting Rooms—Popular Wherever Used.

In every town—we might almost say in every hamlet—there is at least one fraternal organization. It's either a Masonic, Knights of Columbus, O. U. A. M., Knights of Pythias, Y. M. C. A., Press Club, Boys' Club, Women's Club or some similar organization. They are usually excellent prospects for phonographs. The important point is to get in touch with the head part in each one and arrange for a recital at such times as is easiest for all the members to attend.

Out in Illinois recently our representative sold to the lodge rooms of a Masonic order at Savanna a \$150 Edison disc with several records. In Des Moines the Knights of Columbus purchased an Edison disc, and have installed it in their lodge rooms. The Press Club, also of Des Moines, having very elaborate rooms, purchased an expensive Edison disc with a large number of records, says the Edison Phonograph Monthly. Thereupon their secretary ordered another disc for his own home, with several records.

FORGOT WHAT HE WAS SELLING.

Fable of the Dealer Who Was So Full of Arguments That He Couldn't Stop to Sell Goods—A Hint as to the Handling of the "Man from Missouri" and Its Application.

There was once a phonograph dealer whose mentality was cluttered up with arguments. He was muscle-bound in the mind.

Whenever a customer came in to be shown, Mr. Dealer turned on the conversation. He called special attention to the fine old Circassian walnut in the cabinet and laid stress on the graceful lines.

Then he would open up the phonograph as if he were going to take it apart. He would call over the customer and hold a clinic, going into every phase of its anatomy.

Every time the customer started to say something he would interrupt with, "Just a minute, please," and then he would be off on another discourse; this time a technical rhapsody about motors.

Following which came several speeches from Mr. Dealer on the subject of acoustics. Overtones and timbres were all mixed up in the customer's mind and he was looking for a chance to break away and come up for air.

Suddenly Mr. Dealer was called away to answer a 'phone call. The customer beckoned to an assistant.

"Do you know how to work this phonograph?" said he.

The assistant allowed he did.

"Then make it play something," urged the customer.

Mr. Dealer was gone quite a while and he didn't see the smile of appreciation that broke over the customer's features. When he finally came back, says the Edison Phonograph Monthly, he found that the assistant had made a sale and had the money in the cash drawer. Also, he found a note left by the customer. It read:

"I came here to get a musical instrument, not a cross between a mechanical toy and a piece of furniture. Your assistant helped me to find what I wanted."

Moral: Hearing is Believing.

Sometimes silence means only that the man who listened has his opinion unchanged.

C. B. GORHAM MAKES A CHANGE.

Resigns from Denholm-McKay Co. to Become Associated with Worcester Phonograph Co., a Recently Organized Concern.

(Special to The Talking Machine World.)

WORCESTER, MASS., May 9.—C. B. Gorham, of the Denholm-McKay Co., has severed his relations with that concern, and has become associated with the Worcester Phonograph Co., which is a comparatively new concern. W. F. Howes, who at one time was the manager of the talking machine department of the Houghton & Dutton establishment in Boston, has succeeded Mr. Gorham, and he plans some new features for the Denholm-McKay Co. One of his plans is to screen off a part of the rug department and have demonstrations of dancing by a couple three afternoons each week, using a Columbia graphophone to furnish the music. Attention will be called to the demonstrations through the medium of some attractive window display.

SELLS HIGHER PRICED MACHINES.

G. W. Lord Meets with Success in Featuring the Better Grades of Machines in Lynn, Mass.—Reports a Growing Demand.

(Special to The Talking Machine World.)

LYNN, MASS., May 7.—G. W. Lord, of 34 Central square, is one of the large Columbia dealers who is making a great success of the higher priced machines. He has been featuring the \$100 mignonettes for some time past, and his sales have increased tremendously. Mr. Lord makes it a point of running up to Boston quite frequently and conferring with Manager Erisman, and, in this way, he keeps right up-to-date in everything.

NATICK, MASS., A LIVELY CENTER.

(Special to The Talking Machine World.)

NATICK, MASS., May 7.—Though this town is not a large place and is comparatively near to Boston, a large percentage of its citizens can boast the possession of a talking machine; and the medium of distribution for the Columbia outfits is Fairbanks & Sons, who have been doing a most creditable business, especially in the past month. The demand is largely for the higher priced outfits.

More needle styles than you actually need are made in this plant

THERE are many styles and kinds of needles; it is admitted that Bagshaw-steel is the best material, and we make all the styles of needles that have been tested by experts and are acknowledged to be the best means of reproducing sound. Some of these styles are LOUD, SOFT, DUPLEXETONE, which with the many different sizes gives a dominating needle line of unusual strength.

Established 1870

Pioneer
Needle Makers

W. H. BAGSHAW
Lowell, Mass.

Exclusively a

Victor Distributor

Our entire effort—

Our whole force—

Devoted to the sale of the Victor Talking Machine Company's product—why shouldn't we give you the best service in the country to-day?

Is it strange the dealer selling Victrolas and Records naturally turns to us—more so than ever in these times of GREAT DEMAND?

Certain dealers we know depend upon us, absolutely, for their stock. You would find it would pay you to be classed amongst those dealers.

Don't hesitate—start buying **RIGHT NOW**.

Begin thinking of your Fall business—Get in that stock order immediately.

It will pay you.



NEW YORK TALKING MACHINE CO.

81 Chambers Street,

New York City

NEW YORK TRADE SHOWS UP WELL DURING THE MONTH.

Continued Demand for Dance Records Proves Strong Factor in Business Despite Stock Shortage—Noticeable Increase in Local Advertising—Big Gains in Sales Reported—What the Various Jobbers and Dealers Say Regarding Present Conditions.

Business in local talking machine circles the past month has maintained a steady, even gait that has developed nothing startling nor extraordinary aside from the fact that the majority of jobbers and dealers closed the best April in their history. The pronounced record shortage continues to be the main topic of discussion and, in some instances, complaint, while the more popular models of machines are also extremely scarce in most parts of the city.

As was predicted six months ago, the dancing craze shows no signs of abating, although there has been a noticeable switch to some of the newer dances in preference to those introduced last fall. This change, however, has had no effect on the demand for dance records, as all of the new dances find their ideal interpretation through the medium of the talking machine. As it now stands, the dance craze has been the greatest boom to the record business that has ever been introduced. Many dealers can trace a considerable portion of their 1914 profits to the sale of dance records, and with the advent of the summer season there is no real reason why any dealer should complain because of lack of record business. The companies are making every effort to co-operate with their trade in developing their dance record business, and this co-operation is taking the forms of practicable selling helps that are producing results.

A feature of local trade the past few weeks has been the consistent advertising that has appeared in the leading newspapers on behalf of talking machine warerooms or departments. There was a noticeable let-up in "talker" advertising around Lent and Easter, but the past month has witnessed the use of very nearly as much printers' ink as usually appears about Christmas time. Service is the keynote of this advertising, the uniformity of selling prices of the machines and records eliminating the price question from the dealers' advertisements. Machine and record service is extended to all prospective customers, with the assurances that the records carried in stock are perfect and up to date.

Dance Posters Catch the Eye.

The Blackman Talking Machine Co., 97 Chambers street, New York, prominent Victor and Edison distributor, is displaying in its spacious show window a number of dance posters that have attracted the attention and praise of all passers-by. These window posters are distinctive and individual, having been made specially at the company's order. The testimonial on behalf of Victor records given by Mr. and Mrs. Vernon Castle is featured to excellent advantage, while the color schemes of these window displays harmonize with the quality of the illustrations.

Big Business Gain Reported in April.

"Our April business showed the substantial gain of 76 per cent. over that closed last April," said R. F. Bolton, manager of the Columbia Graphophone Co.'s wholesale quarters at 89 Chambers street, New York. "We are naturally well pleased with this splendid report, particularly in view of the fact that last April's business was generally satisfactory, and was ahead of April, 1912. Last month was a record-breaker in several respects, although the most important feature was the fact that the higher priced machines outsold by far the less expensive ones. Our 'Leader' and 'Mignonette' models are selling particularly strong."

Shipping to Summer Resorts.

"Sales of machines during the past few weeks have been very steady," said H. N. Purdy, in charge of the Edison disc department of Hardman, Peck & Co., 433 Fifth avenue, New York. "We have been shipping many machines to well-known summer resorts, together with substantial supplies of dance records, and judging from all indications, this phase of our business will assume imposing proportions during the rest of the month and in June. Our clientele is still evidencing a marked preference for the better grade of ma-

chines, our best selling machine being the handsome \$150 model."

Book on Dancing Stimulates Business.

Apropos of the recently issued Victor book on the modern dances, V. W. Moody, sales manager of the New York Talking Machine Co., 81 Chambers street, Victor distributor, remarked as follows: "The Victor Co.'s book of instructions on the three modern dances, one-step, hesitation and tango, is creating more interest than any piece of literature ever issued by the Victor Co. The demands for "Form 2338," the official ordering number for this book, are actually in excess of the call for the Victor complete record catalog, and the tremendous demand for the latter book is a matter of common knowledge. Due to the fact that all dealers, large and small, urban and interurban, are demanding so many of these dance books, the allotments have of necessity been small and the dealers are all circularizing their best trade and prospects, asking them to come in and get a copy."

Notable Increase in Agencies.

"The various new Columbia agencies around New York established during the past few months all report the closing of a healthy business in April, due to consistent advertising and the demand for the product. The Grafonola Shop, opened May 1 at 143 West 125th street, is located in the best shopping district of Harlem, and is already closing an excellent business. The store is situated in a most convenient spot, being accessible to all lines of transit and opposite the leading Harlem department store.

Takes Charge of Department.

John Y. Shepard has been appointed manager of the Victrola department of the Lawson Piano Co., Third avenue and 150th street, New York. Although Mr. Shepard is inexperienced in the merchandising of Victor machines and records he has started work in his new connection with vim and vigor, and his sales for the past fortnight have been very gratifying, showing a substantial increase over the corresponding period of last year. Before assuming charge of the Lawson Co.'s Victrola department Mr. Shepard visited the establishment of one of the leading local Victrola distributors, where he spent several days acquiring a detailed knowledge of stock system and selling methods.

New Machines Win Praise.

"Edison disc records are being praised by all our patrons," said Dana F. Parkhurst, manager of the Edison department of the Tower Manufacturing & Novelty Co., 326 Broadway. "The tonal quality of the latest shipments from the factory has been termed 'superb' by our customers, and this branch of our business is steadily increasing. The outlook is very bright and our list of live prospects is constantly increasing."

General optimism prevails in the trade just now, the following dealers expressing their satisfaction with business conditions: Benj. Switky (Victor), Christman Sons (Columbia), Krakauer Bros. (Edison disc), Landay Bros. (Victor), Kranich & Bach (Columbia), Greenhut-Siegel Cooper Co. (Edison and Victor), and many others in the local trade.

PROTEST PRICE CUTTING.

Prominent Retail Merchants of New York Hold Large Meeting in Aeolian Hall— Favor Bill Introduced in Congress by Representative Stevens of New Hampshire.

Several hundred independent retailers, representing many different branches of trades, including many prominent talking machine jobbers and dealers of this city, attended a meeting at Aeolian Hall April 24, under the auspices of the Committee for the Promotion of the Interests of Retail Merchants, at which the price-cutting practise of department and "chain," or syndicate stores were severely scored by the speakers. Dr. William C. Anderson, president of the New York Pharmaceutical Conference, presided, and spoke in favor of the bill introduced in Congress by Representative Stevens of New Hampshire, authorizing manufacturers of standard, advertised goods to prescribe the price at which the goods shall be sold by all retailers.

Alfred D. Woodruff, manager of the food supply store maintained by the New York Association for Improving the Condition of the Poor, spoke, and among the other speakers were Congressman Herman A. Metz, of Brooklyn; Ellis L. Holland, of The Journal of Commerce, and J. Leyden White, of Washington. The speakers said the public derived no benefit from price cutting, as the amount taken off the price of one article by the big stores, was added to another.

It was announced that similar meetings are to be held in Baltimore, Denver, St. Louis, San Francisco and Philadelphia and that plans are under way for a large protest meeting in Madison Square Garden on a later date.

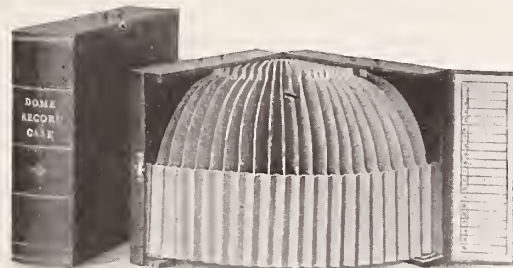
**Dome Record Case**

It holds 20 records, which are readily accessible for instant use. A convenient index shows just where each record is. Notice how the case swings open so the repertoire is displayed. It is constructed along different lines, being reinforced at the bottom with a nickel-plated metal support to keep the records in position.

Keeps Valuable Records Under Lock and Key

Try a sample of each, 10" and 12". If not satisfactory you may return them. Include record numbers you need and perhaps you want a particular model Victrola, which you are unable to get elsewhere. We have every model in stock. Our shipping facilities are the best; thirteen lines of Railroad and five Express companies; also boat lines on the Great Lakes.

By sending us your order you have two of the largest jobbing stocks at your service.

W. D. ANDREWS**Buffalo, N. Y.**

We will help you make money in 33 languages

How many foreigners are there in your locality? Italian, Hungarian, German, Poles—or whatever their mother-tongue may be?

Do you realize how anxious they are to spend their money in your store?



Columbia Records—a splendid repertory in all of the following languages—and a correct catalog for each:

- | | |
|---------------|--------------------|
| Arabic-Syrian | Finnish |
| Armenian | French-Canadian |
| Bohemian | Gaelic |
| Chinese | German-Austrian |
| Cuban | Greek |
| Danish | Hawaiian |
| | Hebrew-Jewish |
| | Hungarian |
| | Italian-Neapolitan |
| | Japanese |
| | Javanese |
| | Lithuanian |
| | Mexican |
| | Norwegian |
| | Polish |
| | Portuguese |
| | Roumanian |
| | Russian |
| | Ruthenian |
| | Scotch |
| | Serbo-Croatian |
| | Slavish-(Krainer) |
| | Slovak |
| | Spanish |
| | Swedish |
| | Turkish |
| | Welsh |

YOU know well enough that music means ten times more to the foreigner in your town than to the American citizen. Especially the music of his own native land—and even more especially if it is sung by the best known artists and played by the best known instrumentalists of his own country—names as familiar to him as your own front door is to you.

We are now prepared not only with a remarkable series of records in 33 languages and dialects, but with the means of getting the business for you.

Our Foreign Record Department will co-operate with you to the limit; we can tell you very nearly how many foreigners there are in reach of your store—and we have a pretty clear idea of what language they speak, too. And we can tell you just how to go about bringing them in. It's the easiest thing in the world—once you have been put in touch with them they will come to you.

The Columbia repertory of foreign records is by far the biggest and best in every language. Most of them were recorded in Europe, and all of them are in the pure native language or dialect.

Good business in every month of the year—no dull June, July or August for you if you have this highly profitable foreign trade coming in.

We can tell you how, and we can help you do it!

Write for particulars to the Foreign Record Department

COLUMBIA



Graphophone Company

102 West Thirty-Eighth Street,

New York City

TALKING MACHINE DEALERS HOLD ANNUAL DINNER

Members of Eastern Talking Machine Dealers' Association and Their Friends Participate in Enjoyable Affair at the Kaiserhof—Listen to Able and Interesting Addresses by Dr. Lee Galloway, Ernest John, Clinton E. Woods and Others—Association Plans.

The fourth annual dinner of the Eastern Talking Machine Dealers' Association, the largest and most successful affair ever held under the auspices of that association, took place at the Kaiserhof, Thirty-ninth street, New York, on Wednesday, May 6, with a particularly large number of dealers and their guests, the jobbers and factory representatives, in attendance. The general acquaintanceship among those present made the affair distinctly informal, and that fact added materially to the enjoyment of the occasion.

The arrangements for the dinner reflected the interest taken in the matter by the officers of the association, John G. Bremner, president; R. Montalvo, Jr., vice-president; Henry Rau, treasurer, and F. L. Steers, secretary, and of a number of the members, and the attendance indicated the growth of the association and the interest taken in it since its organization with a scant dozen members.

Following the dinner proper, President Bremner assumed the duties of toastmaster and introduced the first speaker in the person of Dr. Lee Galloway, professor of commerce and industry of the New York University School of Commerce, Accounts and Finance, who had for his subject "The Principles of Price Maintenance."

Dr. Galloway Speaks on Price Maintenance.

Dr. Galloway, who is one of the recognized authorities of the country on matters of commerce and business economics, handled his subject in a most comprehensive manner and presented a number of forceful and unusual arguments in support of the legal right of the manufacturer to control the resale prices on his trade-marked products.

"Many economists start out by ignoring price," said Dr. Galloway, "but all finally end by acknowledging that price is the most wonderful of all social phenomena. It is the one medium by which society tries to express its estimates of economic values—would it be too much to say social values as well?"

Dr. Galloway then explained in detail the two kinds of commodities—staple and merchandise—the first characterized by their relationship to human wants and the second including manufactured products not of that character.

"The first real distinction between staple and merchandise rests in the nature of the articles themselves. There are only a few grades of steel, but there are thousands of articles made from steel. Each of these articles has certain specific qualities. What corporation, for instance, could get a monopoly of watch springs, or of carving knives, or of razors? Therefore, with the ordinary legal safeguards against the restraint of trade, the manufacturer of merchandising products must set his price under competitive conditions."

After explaining at length the manner in which competitive conditions govern the question of price fixing by an independent manufacturer or dealer as compared to price fixing under monopolistic conditions, and the manner in which the great markets have been developed, Dr. Galloway said: "Not only must the manufacturer adopt the agency method if he would preserve his trade name, but he must adopt this manner of distribution if he would avoid the creation of enormous distribution corporations which would gradually monopolize not only the outlets of distribution but force the manufacturers themselves into a dependent position. The rapid growth of chain stores, mail order houses and department stores indicates the tendency toward concentration in the marketing of goods. Either the manufacturer must be given the right to maintain his resale price—in which case the position of the small distributor might be maintained—or he must establish his own branch house or agency to hold the market for him."

The speaker also dwelt upon the quantity price versus the one price to all from different angles, and likened the present conditions of trade, without fixed retail prices, to the primitive bartering methods wherein both buyer and seller spent much

time and effort in an endeavor to take unfair advantage of each other. He credited national advertising and the general acceptance of advertised trade-marked articles as the standards in their respective classes with placing modern merchandising on its present high plane.

In support of the inherent right of the manufacturer to fix the resale price on a trade-marked and advertised article of his manufacture, Dr. Galloway offered the following original and thoroughly convincing argument: "The manufacturer who spends millions of dollars in advertising his goods to the public creates, as we say, in the minds of the public a disposition to buy and to trust the concern which makes them. An important part of the advertising and an important element in establishing good will is the fixed price which is put upon the article. The community began to associate a certain article with a certain quality at a certain price. The right to this favorable social impression is regarded by the manufacturer as a good will property right, and he claims that when he disposes of his goods to the retailer he cannot in the nature of the case transfer to him also the right to dispose of or sell his reputation or good will at the same time. Therefore he wishes to divide the idea of possession which accompanied all goods, namely, the property right in the physical goods and the property right in the good will. The first of these he is willing to sell to the merchant, but the second he is unwilling to surrender unconditionally into the hands of any other person than himself. Thus he claims that when he sells a razor or a watch with his trade-mark on it, he is not

giving the merchant absolute title to all the property rights connected with it, and hence maintains that he should be permitted to name the resale price to the merchant. In this way the manufacturer can protect the name of his advertised goods against the price cutter, who, by selling it lower than advertised prices, creates an impression that the quality of the goods is not as advertised and so destroys the good will of the manufacturer.

"The whole question of price maintenance is closely associated with advertising. No man can afford to put a brand upon his goods and then spend millions of dollars in advertising if he is making a poor commodity and expects to remain in business. Every dollar he thus spends is advertising inferiority rather than establishing for himself a valuable property right and good will. Advertising in its early stages was almost a synonym for sharp practice merchandising, and the patent medicine advertisement was a type which was very prevalent. However, with the increase in trade-marked goods, advertising became more dependable, and to-day few reputable magazines would dare to take advertising which was palpably fraudulent. Thus the trade-marked goods have not only established standards for the consuming public but they have set standards for the advertising world. The special bargain, the fire and removal sales, etc., which have built up the fortunes of many big department stores and their like, are to-day bringing these stores more and more into ill repute with the public.

"Thus we predict that within a few years laws will be proposed and passed which will define fraudulent advertising, and severe punishment will be meted out to those who attempt to build up a business on the ignorance of a credulous public. And when this time comes we will see more plainly than ever the part that the standard trade-marked goods are playing in elevating business ethics and creating a broader field of commercial dependableness."

ERNEST JOHN, OF VICTOR CO., DISCUSSES "CO-OPERATION".

The next speaker was Ernest John, of the Victor Talking Machine Co., who had for his subject "Co-operation." He was listened to with interest and said in part:

"Co-operation means co-operation and nothing else—it does not mean co-operation up to a certain point. If I attempted to go into all its phases you might, by the time I had finished, have gone home or gone to sleep. You are safe, however, for I myself have suffered too often and too keenly from those who talk 'not wisely but too much.'

"We think we know a lot about the value of gold and diamonds and such things, but the value of co-operation is greater still. The whole social system is built on it. Whether it is a question of mailing a letter or making war on Mexico, we are dependent upon the co-operation of others. A man who earns \$50,000 salary is dependent upon the co-operation of someone else for food and clean shirts. It is true that he pays for them, but if there was no co-operation procurable at a price or otherwise he would have to do these things himself.

"That's how broad the subject is, but we no doubt are more interested in its specific application.

"First: You employ clerks to co-operate with you. Co-operation here means that two or more parties unite their mutual efforts for mutual benefit. When either one of the parties does less than his share we no longer have co-operation, but parasitism.

"Paradoxical as it may seem, there is such a thing as co-operation with competitors. Don't you know how, in a prize fight, there are certain mean tricks which no clean fighter will use, because in the long run they are likely to spoil the sport. For their mutual good they refrain from doing certain things.

"That's co-operation.

"You may say that they refrain from mean tricks because there's an umpire watching them. It may be so, though I would rather hold the other view; but don't forget that there's an umpire watching

the retailer, and instead of one man it is that powerful combination of men we call the public.

"Just as a community, a store or a nation thrives



Ernest John.

only so long as there is a reasonable co-operation for the common good, so with a trade. Every time a man tries to get the best of a competitor by foul means he does, to that extent, help to make business conditions harder for himself.

"The talking machine business has been fortunate—more fortunate than most—but if you remember nothing else that I say remember this, that every time you cut a corner off profitable business the loss is permanent for others, can, will and indeed must, follow you.

"I am not talking about price cutting because I believe you realize how impossible and disastrous that is. I am talking about giving terms which are unprofitable, and all that sort of thing. Depend upon it, you will all have to do business

(Continued on page 24.)



The Columbia sales policy is that of the open shop for the dealer. He can make his own business decisions—and we will boost both his demand and his supply.



(Write for "Music Money," a book "full of meat" for those dealers interested in quick and frequent turnover of capital.)

**Columbia Graphophone Company
Woolworth Building, New York**

TALKING MACHINE DEALERS HOLD ANNUAL DINNER—(Continued from page 23).

on the same basis, and whether that basis is profitable or unprofitable depends upon your policies. It depends on whether you realize that there is a benefit to each individual through co-operation with competitors. You may be positively certain that you yourselves will have to pay the piper for the tune to which you dance.

"On this point my message to you is—get together on the basis of friendliness and good will. To all intents and purposes you gentlemen are like a regiment of soldiers on a battlefield—at least you should be. Your interests are identical with those of your competitors just as surely as the individual soldier's interests are one and the same with those who march at his side.

"I said get together on the basis of friendliness and good will, and I mean just that. Get to know one another—know one another better than you know your customers.

"Here's Brown doing business on one side of the street and Smith doing business on the other side. They are rivals in business, but barring that they're friends. A customer comes to Brown and tells him that Smith has offered to let him have a Victrola for nothing down and a dollar a month. What happens? Brown can laugh in his customer's face if he wishes to, for he knows Smith; they're friends, they've talked over their business affairs, credit extensions and so on, each knows the other and trusts him, each knows that he isn't such a fool as to do business that way. Then the customer's bluff (and such tactics are often used) can safely be called. Without that mutual friendliness, that mutual respect, Brown will try to go one better perhaps, and then what?

"Gentlemen, what is it that you get out of that sort of thing? I'll tell you what you can get and all you can get—rotten business! That and nothing else. Rotten business that isn't worth the having and serves no other purpose than keeping you awake o' nights. What is the use?"

After asking the dealers for their earnest support of the Stevens bill now before Congress, Mr. John continued:

"I have had my say on co-operation from two points of view. For instance, you have a right to the co-operation of your clerks. You have a right to co-operation from your competitors—when you co-operate with them. It is also true that you have a right to co-operation from your manufacturer—when you co-operate with him.

"You have heard what happens to the man who is between two stools, and there is excellent authority for the statement that 'a house divided against itself falls.' Let me tell you that the best co-operation between dealer and manufacturer exists only in the exclusive store, the store which handles one line.

"Do you know what it is that the dealer does when he handles two or more similar competing lines? He acknowledges his own uncertainty as to their respective virtues.

"Before I knew anything about the talking machine business I went into a store where the three most prominent makes were carried in stock. I

was open to conviction to a very great extent, for my experience was very limited. In other words, I was in the same condition of mind as the average buyer. Among other things, I asked the salesman which instrument he thought was the best. His reply was: 'I really can't say.'

"Of course there was nothing else for him to do, but I was actually more confused when I came out of that store than I was when I went into it. Is that the condition of mind, think you, which is most likely to lead to a purchase? Was it co-operation, real co-operation with any one of the manufacturers in question? It wasn't.

"The retailer accepts certain obligations to the public when he becomes a retailer. He assumes the responsibility of supplying his customer with the best article obtainable when the customer on his part assumes the responsibility of paying for such article.

"In most commodities the customer knows nothing of values—he depends on the retailer's integrity. Incidentally, let me say that once that integrity is open to impeachment the end of that retailer comes swiftly. How then, under circumstances such as I have outlined, can a retailer look his customers squarely in the eye and say: 'This is the best,' when there is a monument to his own uncertainty grinning at him from the corner of the store?

"I repeat. When a dealer handles two or more similar competing lines he does acknowledge his own uncertainty, and by so doing he does not help but hinders the making of sales. In other words, he is not co-operating to the best advantage with himself. I know very well that the retailer puts his own money and his own energy into his business for his own benefit, but he defeats his own ends when, instead of stimulating the enthusiasm, he stimulates the confusion of his customers. I shall be told that there are two sides to every question. There are. But both of them can't be right. I think I know most of the arguments which are used in favor of having more than one line, although it has been my misfortune to have met no argument which justifies the practice.

"The one most commonly used is that in catering to the general public a merchant must be able to satisfy varying tastes. If that were so, the only successful retail establishments would be the de-

partment stores. But I would rather own Tiffany's than the best jewelry department in town, and so, I think, would you.

"Take the case of—well, a shoe dealer. When shoe dealer offers the public the best available shoe, the shoe which gives the greatest satisfaction to the greatest number of his customers, he does not, in handling that line, debar the public from procuring some other shoe—at some other store. I grant you he may lose the sale of an occasional pair of shoes, but what of that, if the line he carries is, generally speaking, the most satisfactory to the public with whom he does business?

"No one can get all the business there is, no matter how many lines he carries. Is it wisdom or policy to spend money and effort in pushing less satisfactory goods when the same money and effort might have been more profitably expended on the goods best suited to your own particular market?

"You can't possibly inject into your customers more enthusiasm than you yourself possess. Straddle the issue and you will find that your customers will follow suit. They, too, will 'straddle' until someone else, by the sheer force of his own convictions, carries off the prize bodily before your eyes.

"Please don't misunderstand me. I did not come here to-night to proselytize. I came to talk about co-operation as I see it, and I am dealing only in co-operation's first principles.

"I do not say to you, 'Throw out every other line and handle the Victor.' What I say to you is this: 'If you feel that the Victor will suit the majority of people best, handle that, and that only. If you think the Columbia is best, handle that, and that only.'

"A man cannot serve two masters. If you haven't any convictions of your own you can't expect to convince your customers. True enough, if your guess goes wrong you may be out of business in three months, but you will have learned the lesson in the cheapest way, and you will have paved the way for a future success.

"There would be no possible use in my coming here and rehashing for your benefit a quantity of second-hand platitudes. My only chance to say anything of real value is to express my honest convictions. That, Mr. President, is what I have endeavored to do."

CLINTON E. WOODS TALKS ON "SOUND RECORDING"

One of the most interesting and instructive addresses of the evening was that of Clinton E. Woods, E.E., M.E., of the American Graphophone Co., who offered "An Explanation of Sound Reproduction as Related to Talking Machines."

"Generally speaking, sound is primarily created by four things: First, by a fractional rubbing of some kind, such as drawing the bow of a violin across its strings; second, by a blow of some kind, such as the tongue of a bell on the bell itself; third, by the rapid movement of air over a vibratory medium, like the reed of a clarinet, the vocal cords

of the throat, etc., and fourth, the movement of air through certain forms of confinement, like a flute or the pipes of an organ, the results, which in turn disturb the air and set up a wave movement, the air thus acting as a medium of travel for the sound so created, different sounds being represented by a difference in the number of vibrations per second, with a resulting difference in the form of the sound wave.

"Sounds are audible to the human ear from about thirty vibrations per second to 16,000 or

(Continued on page 25.)

TALKING MACHINE DEALERS HOLD ANNUAL DINNER—(Continued from page 24).

20,000 per second, but in music sounds are used for about seven octaves only; that is, from forty vibrations per second to a little over 4,000 per second, and it is this range of vibration in sound that we have to contend with in the design of a recorder for talking machines.

"From this we can see that for musical reproduction the needle arm on a reproducer is called upon to make anywhere from forty to 4,000 vibrations or blows on the diaphragms a second, and to jump from perhaps forty to 4,000 times in the thousandth part of a second, and we can well wonder at the possibility of its being able to do so,

"We wonder at this still more when we consider the fact that all the different vibrations from instruments of an orchestra are put into one wave line on a record. We would naturally suppose that as each different instrument has a different tone wave and a different set of vibrations for each note, such a confusion of sound would be set up when they went into a recording instrument as to result in nothing but a conglomeration of noise, but such is not the case, for when the sound of an orchestra is recorded it imprints on the wax record a single composite wave line corresponding to a composite photograph; in other words, there is one general sound wave formed of all the other sound waves, which precipitates itself onto the diaphragm of the recording instrument and thus produces in the wax record a single wave line corresponding to it, and this in turn is used in connection with the reproducer in such a way that it throws off the same identical composite sound that was put into the original wax.

"This is brought about by the well-known process of putting a pointed needle in the groove of the finished record and allowing the record to rotate under the needle at the same speed at which the record was made. This causes the needle arm to vibrate (according to the wave groove on the record) against a flexible diaphragm, it might almost be called a miniature drumhead, and this in turn agitates the air on the inner side of the reproducer by setting up vibrations and consequently corresponding tone waves in the air, whose only means of exit is out through a tone arm and horn of proper proportion to amplify the volume required.

"Amplitude is another thing that must be taken into consideration in the proper design of a reproducer; that is, the minimum and maximum length of stroke to be made in order to get perfect vibration for long or short tone waves; that is, loud or soft tones. Right here is where we come to one of the most difficult things in reproducer design. If the diaphragm is too thick we do not have elasticity enough in it to give a full length stroke and so get a tubby sound; if it is too thin we have what is known as a raspy or edgy sound. At no point in the operation of a needle arm must the diaphragm be subjected to any mechanical strain; in other words, it must not exceed the limits of its elasticity. From this it can be seen that there is a mathematical relation between the diameter and the thickness of a diaphragm and the length of the needle arm in both directions from its pivoted center.

"Next, let us consider what a record is. It is a flat disc with a spiral groove, commencing at the outer edge and running in toward the center, which groove represents a sound recording of some kind. A record which will play about four minutes has, in the total length of its groove, an average of about 480,000 waves or vibrations; therefore, in playing a tune once through, the needle is made to oscillate against the walls of this groove something like 480,000 times, which, in turn, is delivered to the diaphragm of the reproducer. The depth of this groove is three one-thousandths of an inch; its average width is six one-thousandths of an inch, while the thickness of the wall between the spirals is on an average four one-thousandths of an inch, from all of which we can see that a tremendous amount of energy is required from an infinitesimal amount of material.

"We do not consider a record good in its wearing qualities unless it will play on an average at least 200 times; therefore before a record is worn out it will have delivered something like 96,000,000

complete strokes of the needle arm to a diaphragm, and the energy that will have been consumed in this work will have been equivalent to 18,000 foot-pounds, or the raising of 18,000 foot-pounds one foot high in one minute. This gives us some idea, in a general way, of the work the face of a record has to be constructed to do.

"Therefore a matter of great consequence is the selection of proper materials to do it with, as this terrific vibratory bombardment must have a material that will not only give great wearing qualities but will run as frictionless as possible; that is, must be as free from scratching due to the mechanical slide of the needle as possible; and, furthermore, must be a material that is absolutely impervious to moisture; otherwise the records will be very short lived, due to atmospheric or climatic variations.

"Such, in brief, are the elements that we have to deal with down to the present time in the development and use of the talking machine. Recent experiments and developments, however, lead me to say that I believe the talking machine business to-day is about as near being in its infancy as any industry in this country. For instance, the whole development of the art to-day has been practically



Clinton E. Woods.

one that is purely mechanical. Recent experiments in our laboratory show possibilities of coupling electricity up in connection with this work, and I have no hesitation whatever in saying that the time is now near when there will be some remarkable, some most remarkable, changes in the talking machine art and product.

"There are no great obstacles at the present moment to making a record in New York from a band playing in any other city within a radius of 100 or even 1,000 miles, and this can all be done by some well-known electrical methods in connection with some recent inventions which we are working on, and, gentlemen, this means a great deal to us.

"For instance, there is no reason whatever for confining the reproduction of sound to individual appliances as we do now. There is a possibility of there being a general diffusion of this throughout a room, so that it is not localized at any one point but will be the same in any part of the room and have a much greater volume and far superior quality of tone. There are, in fact, two paths before us for making electrical recording. One purely electrical, by which we cut into wax, and one magnetically, in which we will not use wax.

"There is another proposition which I think to be still more wonderful in its possibilities. Within sixty days I have actually seen a photograph of sound, which opens up an entirely new and wonderful field for us in the art of sound reproduction, which again leads me to say that we are approaching a new era in the talking machine business. If sound can be photographed we can enlarge such a photograph as many times as we want to, the same as they do in moving pictures. This will give us an opportunity to make a full analysis of any one

voice, instrument or concerted piece of any kind. Therefore we could take the voices of great artists and make a very minute analysis, a mathematical analysis, if you please, of the relative value of such voices. We could take the voice of a young singer and make an analysis of it and determine just what possibility lay before its possessor, often times saving a vast amount of time and money in its development, if not found up to some certain standard, or again, often encouraging to a complete development voices which might otherwise stay hidden.

"That home recording will soon be with us I have no doubt whatever, which means that a large amount of correspondence in the future will be dictated to a machine and reproduced by the recipient. The time is not far away when we will possibly have voice studios where anyone may go and have a record of their voice made as they now go and have photographs of themselves made. Posterity records, they might well be called. I said before that our work at the present time was very mechanical, and notwithstanding all talk to the contrary, we do not get perfect reproduction at present. To illustrate this: If tone waves were an inch in length in each of their vibrations, out of this original source of sound we have to perform a certain mechanical work, namely, the cutting of wax for preserving the sound or reproducing it. If we absorb two-tenths of an inch in the tone wave in the mechanical work of cutting the wax it is utterly impossible to get a perfect reproduction, because we are going to have only eight-tenths of an inch swing to the sound in the groove on the wax as against a full inch in the original sound, and by this difference there will always be a difference in the actual reproduction from its original source, this difference varying in different voices and different kinds of music. As I said before, there are two paths open to us for the making of sound recordings which are different from those now used, in which there will absolutely be no loss in the registration of the original source of sound. This is very important to a commercial development other than one of entertainment; within the last three or four months I have had some wonderfully satisfactory experiences in these things. You can readily understand that if we can reproduce sound, giving the full value of the original source, also without mechanical contact, we will probably reach as near a state of perfection in this science as it will be possible to go.

"The strong commercial phase in the near future of sound production is going to be in the taking of telephone and telegraphic communications, whereby we will get an actual record. The necessity of this you will perceive at once if you will stop to consider the tremendous volume of business which is daily transacted over the telephone, of which there is absolutely no record that could be produced in court or otherwise as a business transaction. I have seen this performed within the last month and I have taken, myself, telephone communications and put them on record from widely different sources, so this is not only a possibility but a probability, for I have seen apparatus that would do this work over a 1,500-mile circuit."

Other Addresses Made.

After a short address by G. W. Hollowell, manager of sales for Thomas A. Edison, Inc., the toastmaster introduced Francis L. Plummer, of the American Fair Trade League, who made a plea for the support of the talking machine dealer in the work of the league for price maintenance, and who also discussed the Stevens bill at length.

The final speaker was Edward Lyman Bill, editor of The Talking Machine World, who spoke of the benefits of association to talking machine men, and who advocated that the jobbers and dealers of New York get together in one large mutual association for general trade protection and betterment, with increased individual benefits as the final aim.

John G. Bremner, president of the association, also announced that he favored the bringing together of all the various jobbing and retail interests in the local talking machine trade into a large association that would prove a big factor in handling the many business and legislative problems that face the talking machine men to-day.

A NOVEL MUSICAL INSTRUMENT.

Much Interest Being Manifested in the New Instrument Regarding Which Mr. J. Hoffay Expects to Make an Announcement at an Early Date—Possesses Many Distinctive Features That Have Aroused Attention.

Matters have greatly advanced with J. Hoffay, of 67 Egerton Gardens, South Kensington, London, England, who expects to put on the market his greatly looked for instrument at an early date. Mr. Hoffay is very sanguine as to the trade field waiting for him. His instrument is fully protected by patents, which are already applied for in as many as forty-two countries.

Mr. Hoffay expects to have some definite information ready during the current month. His line of goods will be very attractive. He asserts that several features of his inventions will make certain the capture of the world's market, among which stands prominently the magnificent round musical and natural tone of the reproduction and also the point that one soundbox, without being detached, is all that is necessary to play perfectly all sorts of records. Such arrangement ensures perfect reproduction at all times with all makes of disc records—phono or zig-zag cut.

Other features will count as well, although the main one is perhaps the extreme simplicity of every part composing the instrument.

The announcement as to the trade-mark or name under which these instruments are to be known will be made shortly in this paper, together with the name of the winner of the £10 prize.

Catalogs are now being prepared and will be ready for distribution at an early date. Dealers should apply for same at once.

If you wish to be popular with other people don't show everybody how popular you are with yourself.

Some men are so afraid of hurting other people's feelings that they won't even grin when the weather man falls down on his prediction.

AN AID TO MERCHANTS.

Edison Advertising Compiled from Newspapers Which Is Used to Good Purpose by L. C. McChesney—Other Plans to Help Agents.

A striking aid for retail phonograph merchants was recently created under the direction of L. C. McChesney, advertising manager of Thomas A. Edison, Inc., Orange, N. J., when the department compiled from newspapers some twenty-four advertisements from all sections of the country in which the new Edison Diamond disc phonograph is exploited. These were reproduced in the regular size, and the various sheets were sent to all the Edison dealers to show them just what was being accomplished by their fellow merchants throughout the country. Under each of these advertisements were brief criticisms and suggestions for improvement, so that new dealers might be guided in their advertising work to the end that their publicity work would be of the strongest possible character.

In addition to the foregoing, Thomas A. Edison, Inc., also publishes a set of advertisements for dealers, covering many important points of construction and publicity, which, together with the foregoing set of proofs, furnish this trade with a tremendous amount of ammunition for creating new business.

Mr. McChesney spoke very highly of the methods and space used throughout the country by Edison dealers in featuring the new Diamond disc phonographs, and the trade is receiving the co-operation of this advertising office in order to secure the maximum results from their work.

NEW COLUMBIA REPRESENTATIVES.

Among the latest additions to the lists of Columbia representatives are the Thiebes Piano Co., St. Louis, Mo.; Daly & Poole, 181st street and St. Nicholas avenue, New York, and W. H. Becker & Co., Gloversville, N. Y. The Thiebes Piano Co. is one of the most successful piano houses in St. Louis and is planning to institute an aggressive



NYOIL

For polishing
varnished woodwork it is
extremely satisfactory. No oil is so clean.

Ask your watch repairer whose
oil he uses on your watch.

campaign on behalf of its Columbia department. All of these new agencies will pay particular attention to the sales of Columbia dance records.

FAMOUS PITCHER BECOMES BUYER.

(Special to The Talking Machine World.)

GETTYSBURG, PA., May 6.—The People's Drug Store, of this city, Victor dealer, sold a few weeks ago a Victrola XI to Eddie Plank, the famous pitcher of the Philadelphia Athletics, world's champions. This past master of the pitching art is an enthusiastic admirer of the Victor products, and purchased a substantial amount of Victor records to go with his machine.

A diluted optimist is a man who, though he can't be happy, insists on being a little less unhappy than his neighbor.

The Masterphone

GIVES

Perfect Detail

Rich Tone

Full Volume

Records remain perfect forever, as Victor Fibre Needles are used. Your customers will like the Masterphone, for it adds immeasurably to the value of their instruments.

YOU EARN ADDITIONAL PROFITS.

Write for Sample and Discounts.

Steel
Needles
Masterphone
\$1.00

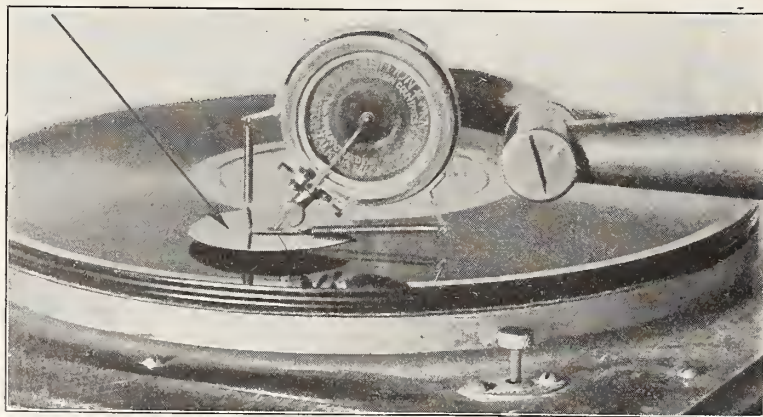

Fibre
Needles
Masterphone
\$1.50

THE MASTERPHONE CORPORATION

Suite 1924

61 Broadway

New York City

ARTISTIC ENVIRONMENT COUNTS.

Its Value Demonstrated in the Display of Edison Disc Phonographs at Hardman House, New York—An Idea of Its Effectiveness Apparent from the Photographs Below.

As symbolic of the standing of the present-day talking machine business, the accompanying views of the Edison disc department in the establishment of Hardman, Peck & Co., New York, furnish an

Hardman, Peck & Co. occupy an important position in the ranks of high-grade piano manufacturers and cater to a high-class clientele. Their products are sold by aggressive dealers throughout the country, and in arranging to handle the Edison disc products in their beautiful home office, Hardman House, the company paid a marked tribute to the merits of these machines and records.

The Edison disc department is located on the fifth floor of Hardman House and, as will be

fyng success, the company's piano clientele being quick to appreciate the musical worth of Edison disc machines and records. The higher priced machines have been the heaviest sellers in this department, while all types of records have met with a ready sale. Ashley B. Cohn, vice-president of the company, exercises a general supervision over the Edison department, while H. N. Purdy, well known in the local trade, is in personal charge of the Edison business.

TRITON CO. STATEMENT

Sent to the Trade in Answer to Certain Legal Phases in Connection with the Triton Phonograph and Its Manufacture.

The following letter is being sent by the Triton Phonograph Co., 41 Union square, New York, to its representatives and other members of the trade: "To Our Customers.—We are informed that the American Graphophone Co. is advising the trade that it has brought suit against us on certain of its patents. We wish to notify our customers that this suit will be vigorously defended by us, and we have the utmost confidence in the outcome of the litigation. We are advised by our patent counsel, Waldo G. Morse and John L. Lotsch, of 10 Wall street, New York, that we do not infringe any valid and existing patents owned by the American Graphophone Co. or any other company, and that we stand ready to defend our customers against all litigation. If you are served with any papers, communicate with us immediately.

"To the Trade—If you are sued, it will be to your interest to communicate with our patent counsel or us immediately.

"TRITON PHONOGRAPH CO., INC.,
"By Joel A. Kraus, as President."

VICTROLA CONCERT IN CLEVELAND.

Eclipse Musical Co. Provides Elaborate Program and Attracts Large Crowd of Music Lovers—Local Quartet Helps Out.

(Special to The Talking Machine World.)

CLEVELAND, O., May 8.—On Wednesday evening of this week the Eclipse Musical Co. gave a most interesting complimentary concert at the store of the company, 1130 Euclid avenue, and at which the music of the Victrola, in a variety of standard and operatic selections, was interspersed with selections by the Cleveland Apollo Quartet, with Charles T. Ferry as accompanist.

The concert was well advertised and attracted a large and representative crowd of music lovers. In order to make the concert of practical value the numbers of the Victor records used and the names of the artists making them were printed in the program.

EDUCATIONAL RECORD CATALOG

Which Will Prove of Real Assistance to Dealers in Developing Business.

The educational department of the Columbia Graphophone Co. issued the early part of the month a catalog of educational records which should prove of real assistance to Columbia dealers in developing their business in this field. This catalog was compiled with detailed care and consideration, containing an index that lists 24 sections under which Columbia educational records may be classified.

Among the various classes of music listed in this book, the majority of which are also sub-classified, are the following: Band selections, chamber music, choruses, dance music, glee clubs, grand opera, holy days, instrumental duets, light opera, lullabies, oratorios and cantatas, orchestral, overtures and suites, patriotic, piano solos, quartets, sacred songs, secular songs in English, solo orchestral instruments, standard songs (foreign) symphonies, talking, whistling.

It isn't always the brainiest man who forges ahead. A low-brow will often cause the crowd respectfully to make way for him—if he happens to be carrying a ladder.



Exterior and Interior of Their New Building, 483 Fifth Avenue.

1. Edison Disc Reception Room. 2. One of the Edison Sound-Proof Booths. 3. Where the Edison Disc Records Are Kept and Delivered. 4. Exterior View. 5. Entrance Floor—Approach to the Edison Disc Department.

The opening of this new department in this well-known piano house was chronicled in detail in the columns of The World a few months ago, but these photographs tell their own story of the dignity and quality which characterize the furnishings of these Edison disc warehouses.

seen by the illustrations herewith, the general reception room and demonstration booths are all in perfect harmony with the reputation of the Edison disc products and the standing of Hardman, Peck & Co.

In the few months that it has been open, the Hardman Edison department has achieved a grati-

"Standard" Record Cleaner

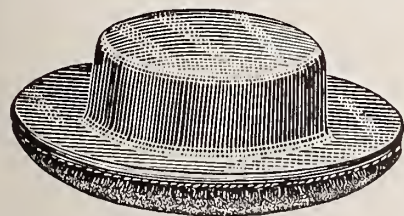

Price, 50 Cents, List

ARTISTIC AND ATTRACTIVE

Grips the record surface and clings as if on rails.

Extended brush area cleans record with one sweeping circuit.

Send 10 cents in stamps for a sample cleaner. Write on your business letter head only. Place regular orders through your jobber.

STANDARD GRAMOPHONE APPLIANCE CO.

173 LAFAYETTE STREET,

NEW YORK

INCREASING BUSINESS VOLUME AND DECREASING LOSS.

The Work of the Credit Man in Helping His House to Meet and Overcome Diminishing Business by Making Forced Expansion of Trade Really Safe—Speeding Up the Slow Accounts—Some Excellent Advice by Norman Fetter, of St. Louis.

Norman Fetter, vice-president of the St. Paul Association of Credit Men, made some timely remarks recently when he said:

The question that confronts every mercantile establishment is how to maintain the net profits in the face of the diminishing margin of profits and the increased expenses. So far only one solution has been found, and that is to increase the volume of business. By turning over the capital more frequently a fair return can still be obtained even with smaller profits and increased expenses. It should be borne in mind that the increased volume of business is not an end, but merely a means towards the end; and that is, the net profits.

Furthermore, when merchandise is sold, not for cash or delivery, but under an agreement on the part of the purchaser to pay at some future time—whether a day, a week, a month or a year hence—another factor enters into the calculation of the net profits, and that is, will the purchaser pay as agreed? Now, it is at this point that the credit man's duties begin, and in their performance he is confronted by two indisputable and at the same time antagonistic propositions. The first is, that the house must do a certain volume of business in order to show a net profit at the end of the year, and if the merchandising end of the business is properly conducted, the larger the volume of business the greater the net profits will be. The second proposition is, that losses on bad accounts must not be so great as to materially impair the net profits. Hence it may be stated that the fundamental duty of the credit man towards his firm is to assist in doing the largest possible volume of business with the least possible amount of losses.

Problem That Confronts the Credit Man.

If the problem that confronted the credit man were merely to avoid all losses on bad accounts, his task would be a great deal easier than it really is. By declining business from all doubtful customers and insisting upon prompt payment as soon as accounts become due he could probably escape losses, or very nearly do so; but it is safe to say that, by pursuing such a course he would reduce the volume of business of an ordinary wholesale house all the way from 25 to 50 per cent. It is superfluous to ask what would happen to the net profits if such course were pursued, or to ask what would happen to the credit man.

On the other hand, by accepting all orders without regard to the safety of the account, his firm would soon cease to be in business. It would become an asylum for all the financial decrepids or derelicts in his territory, and ultimately the losses on bad accounts would become too heavy to carry.

Combination of Two Elements.

It is, therefore, the combination of these two elements, the doing of the largest possible volume of business with the least possible amount of losses, that constitutes the problem of the credit man. This is the circle that he must forever attempt to square, for it must be admitted that no perfect solution of the problem is possible.

There should be harmonious co-operation between the sales department and the credit department. Let every salesman thoroughly understand that the credit department is alive to the necessity of doing a satisfactory and increasing volume of business, and that it is willing to run reasonable credit risks in order to get new business; but also let every salesman thoroughly understand that he is to co-operate with the credit department in preventing losses on bad accounts, and that he is not expected to solicit business from people who are known to be in poor credit standing. The result of such co-operation will be that the salesmen will avoid undesirable customers, and will devote their time, energy and the firm's money to securing a good line of customers. Such a course will head off a lot of trouble before it ever gets started, always a desirable thing to do.

The Slow Accounts.

Of course, we all have a great many accounts on the books, and, therefore, to accomplish results it is necessary for the credit man to concentrate his attention on the slow accounts.

As a rule, the customers who discount their bills or pay at maturity need comparatively little attention. In dealing with the slow accounts it is necessary for the credit man constantly to bear in mind that they form an important part in the volume of business done by his firm, and, what is still more important, the net profits realized from their business is considerable, for a slow customer is not nearly as apt to haggle about prices as the one who discounts his bills.

On the other hand, a slow account always presents to the credit man's mind the possibility of making a loss sooner or later. There is a proverb that "a long sickness is sure death," and usually long continued and chronic slowness in meeting bills presages business death. The credit man must, therefore, watch each slow account individually and constantly with a view to noting whether or not there is any improvement. He must ascertain, if possible, the reason for the customer's slowness. It will be readily seen that if the credit man can obtain the reasons for slowness of payment, he will have a flood of light to guide him in handling each individual account.

Clinton E. Woods, supervising engineer of the American Graphophone Co., Bridgeport, Conn., gave a very interesting address last week on "Reproduction of Sound" before the Men's Club of the Second Reformed Church, Hackensack, N. J. Mr. Woods gave a brief explanation of the construction of the reproducer. He explained the number of vibrations measured in the various notes, including the scope of music as well as scope of sound that could be heard by the human ear, and he explained the enormous energy represented by the surface of one disc record in the number of strokes which the needle arm of a disc reproducer gives to the diaphragm, measured according to the number of vibrations, etc., during the playing of one ordinary finished record.

MUTUAL.

"This," said the police judge, in the throbbing silence of the court room, "this is the seventeenth time you have been arrested. The country is wasting money trying to make you behave. I never want to see your face again—do you understand?"

The prisoner nodded an unsteady head.

"Judge," he whispered, "I asshure y' zat feelin' 's entir—hic!—tirely mutual. I re—hic!—reshiprocate!"

NEW TYPE OF VICTROLA XI.

Announcement Regarding This Latest Addition Just Made by Victor Co.

The Victor Talking Machine Co. sent out to its trade this week an announcement of a new type of Victrola XI, the \$100 model. This new style, which is designated as Victrola XI, Type "F," embodies a number of distinctive improvements over the model now on the market, including an interior arrangement for holding the records so that they may be kept lying in a flat position instead of standing on edge as formerly. Each shelf will hold eighteen records, with a portion cut away to allow free access to the records. There are eight shelves in this arrangement.

The company announces that the new type will be slightly larger in this three dimensions than the Victrola XI now being sold, and that shipments will be made in about two weeks. No change in price is announced and the company states that it contemplates no further changes in this model during the balance of this year.

SUPERVISING DANCE ROLL MAKING.

Miss Emily O'Keefe, assistant inspector and teacher of athletics, is supervising the making of all folk dance records for the Columbia Co. Miss O'Keefe is well known to educational authorities throughout the country, as she is assistant to Dr. Crampton, who is director of physical training in the New York public schools. The Columbia Co.'s educational department has just issued a very comprehensive catalog of educational records which should prove of considerable value to the dealer.

RETURNS TO EUROPE.

Louis S. Sterling, manager of the British interests of the Columbia Graphophone Co., sailed for England Saturday on the "Oceanic" after a month's stay in this country. While here, Mr. Sterling attended the wedding of General Manager Lyle's daughter and the twenty-fifth anniversary dinner of the Columbia Graphophone Co. A. H. Brooks, superintendent of the London recording department of the Columbia Co., will probably sail for England early next week.

WHERE THERE IS NO BARGAIN DAY.

New ideas are slow getting into some quarters. Who ever heard of a bargain day at a coal yard, for instance?

Things go so fast nowadays that the "model" husband of 1914 is hopelessly out of date by the time spring gets here.

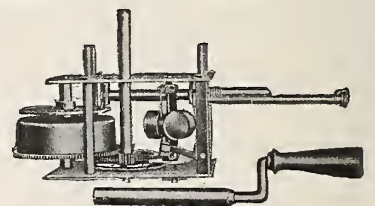

TRITON MOTOR

is simplicity and perfection combined. Not a surplus piece of metal about it—every part has its definite function to perform. So the cost has been kept exceedingly low. All parts of which are made in our Factory at Berlin, Germany. The TRITON MOTOR is simple, solid and durable. It is noiseless and may be wound while the instrument is playing.

For prices address

TRITON PHONOGRAPH CO.

41 UNION SQUARE

NEW YORK

SEND FOR SAMPLES "DUSTOFF" RECORD CLEANERS

Try them on some old or dusty record—you will be surprised, on playing the record, at the resulting clear and distinct tonal reproduction.

Clean all Makes of Records

"DUSTOFFS" are made of specially selected high-nap wilton fabric, which is specially processed, and gets into the minute sound grooves of the record.

As Nothing Else Can

In attractive display cartons. Liberal trade discount.

De Luxe Model	Regular Model
Metal Holder	Wooden Holder
Retails 50c.	Retails 15c.

Sold by most Victor and Edison jobbers, and by all Columbia distributors.

SAMPLES: Sent postpaid on approval to dealers writing giving jobber's name.

MINUTE SHINE COMPANY

183 Minute Shine Bldg. Providence, R. I., U. S. A.

NOTICE—All dealers and jobbers are cautioned against handling or selling record cleaners infringing against the "DUSTOFF" De Luxe (Simpson Patent) under full penalty of prosecution.

CONTINUED ACTIVITY IN QUAKER CITY TRADE.

Growth Most Marked as Compared with Last Year—Blake & Burkhart's Attractive Quarters—Alterations at Wanamaker Talking Machine Rooms—Buehn Progress—Columbia Wholesale Business Expanding Enormously—New Edison House—News of Month.

(Special to The Talking Machine World.)

PHILADELPHIA, PA., May 8.—The Philadelphia talking machine business, during the month of April, has shown the same satisfactory increase as during the other three months of the year. The increase is quite marked over last year, and each of the four months thus far shows a substantial gain with the prospects, as they look at present, of a continuation of such business for the rest of the year.

The Victor Co. has been keeping the dealers fairly well supplied, both with machines and records, and there is very little complaint at present of a shortage of goods. The only change of any note in the Victor is their announcement that the No. 11 will shortly come out with a new case design. The machine will be an inch higher and an inch wider, with a series of flat shelves similar to a music cabinet, giving a sufficient capacity to hold as many records as the average person cares to possess.

There has been no change in the Edison situation within the month. The local newspapers have been carrying large advertisements of this firm, and the dealers here seem to be doing well. On April 15 the new firm of Blake & Burkhart opened their warerooms at Eleventh and Walnut streets. They have most attractive parlors, richly furnished, and two large hearing rooms. In the basement they keep their stock. Every Monday afternoon they have special recitals from 3 to 5 o'clock, which have been attended by select guests brought there through personal mail effort. This firm consists of Herbert E. Blake and Irvin H. Burkhart. This is their first venture in the talking machine business, but they have been successfully engaged in a similar line of merchandise.

The Talking Machine Co., with three large stores in Philadelphia, has been doing a very fine business. It is arranging to make quite a change in its Broad and Walnut street store during the summer. It will cut through and have a number of salesrooms upstairs in addition to those on the first floor, in order that its customers will have more privacy. Its business is growing daily and it needs more room. The Columbia avenue and Broad street store has also been doing a very good business, and it is the best location outside of the center of the city.

Extensive alterations are to be begun at once in the Wanamaker talking machine department. A row of booths, which have already been constructed and are ready to be placed in position, will be erected in front of their Louis XV. room. The space will permit of double the number of rooms they have at present. The large room, which at present is filled with instruments, will hereafter be used merely as a concert room, and will be handsomely furnished and with a raised platform at one end, on which machines will be placed and concerts given from time to time.

Louis Buehn reports that his business in April was substantially ahead of last year; in fact, it ran ahead by a greater per cent. than any previous month of this year. His Edison dictating machine business has also been most satisfactory in April. An order has been closed for sixteen machines with the Atlas Powder Co., of Wilmington, Del., and at present a demonstration is being conducted with the Dupont Co., where he hopes to place a number of machines.

A new talking machine needle is about to be placed on the market in this city. It is not a diamond point, and it is made by a process known only to the manufacturers. When adjusted, no change is necessary for a long period, each needle playing at least 500 records before it becomes in any way impaired. It is said to be perfectly noiseless, and with no wear on the record. These needles will be retailed for 35 cents a piece.

H. H. Stewart, manager of the Gimbel Bros.' department, has been ill for a couple of weeks

with pleuro-pneumonia. For a long time little hope was entertained for his recovery, but he is now passed the critical point and is rapidly improving.

H. A. Weymann & Sons report that their Victor business has been most satisfactory. They have been having splendid success with their dance records, which they have been advertising heavily, giving away a little booklet that explains the dances to every purchaser of the records. Harry Weymann states that the first four months of the year have shown the greatest increase in the Victor line that they had in any four months in the history of the house. The demand still exceeds the supply. Their William H. Doerr is at present traveling through New Jersey, and Norbet Whately is through the State on his usual monthly trip. William Brewton is looking after the business in this city.

The retail business of the Pennsylvania Talking Machine Co. has been all that the management anticipated, and the Columbia wholesale business has been growing in a most satisfactory way. April of this year, Mr. Eckhart says, their business was better by 75 per cent over last year. "One thing that is particularly gratifying," he

says, "is the very prosperous condition of most of our accounts. Every dealer on our books is enjoying a very big business, which I attribute to the fact that we are giving them perfect satisfaction and perfect service. We have made a number of new and important accounts and have added several that were most desirable to our list during April."

The Pennsylvania Co. has rearranged its working force in the basement of its store—its shipping department. It has entirely reconstructed its stock rooms to better facilitate its business and give the dealers better and quicker service than ever before. By this rearrangement, it has been able to increase its Columbia record capacity by fully 100 per cent.

PAUL H. CROMELIN IN NEW FIELD.

Paul H. Cromelin, well known in the talking machine trade as vice-president of the Columbia Phonograph Co., and later as manager in Great Britain for Thomas A. Edison, Inc., is now located in New York as American representative for the Cosmofotofilm Co., with headquarters at 110 West Fortieth street. Mr. Cromelin has sent out an invitation to many of his friends in the trade to attend the first performance of the London Film Co.'s big photo play, "The House of Temperley," by Sir Arthur Conan Doyle, at the New Strand Theater, New York.

Premonition is one of many apprehensions which has happened to be fulfilled.

WE DON'T—DO YOU?

Do You Believe These Claims?

What does it mean to say, "We are the largest"—"We are the best"—"We always ship complete the same day," etc., etc.?

"Bosh"—Idle, Careless Claims

Who wants them? We don't know who is the "BIGGEST," etc., because it is not possible to get the details of a competitor's business.

You Want A Jobber to "Make Good"

We are here to SERVE YOU and have you JUDGE by what WE DO.

Try It Now—Send An Order

Let it be MACHINES or RECORDS. Don't let your Competitor be a "BLACKMAN DEALER" at your expense.

Very sincerely

BLACKMAN TALKING MACHINE CO.

J. NEWCOMB BLACKMAN, Pres.

97 CHAMBERS ST., NEW YORK



DEVELOPMENT OF AD SERVICE.

Success of the Abbott-Young-Adair Co., Chicago, in Catering to the Publicity Demands of the Talking Machine Trade—Most Convenient Cover for Mailing Record Supplements—Speeds Up the Reorder—Sales Aid.

(Special to The Talking Machine World.)

CHICAGO, ILL., May 9.—A business that has developed with proportionately the same speed as the talking machine business itself is that of the Abbott-Young-Adair Co., 542 South Dearborn street, Chicago.

The business of this company is that of providing an advertising service and sales promotional aid that is designed for the entire music trade. The success which the company has found in the talking machine trade has been especially noteworthy, due, in a great part, to the response that dealers the country over have met with following the use of the Chicago company's covers for mailing out record supplements.

These covers are permitted to be used by but one dealer in a town or territory, and possess every requisite of result-producing copy. They are attractive in design, are strikingly individual and link the dealer's name to his product in a fashion that creates an inseparable association between the two.

As the record buyer goes through the monthly supplement he can check without the slightest inconvenience the records desired on the detachable post card which forms a part of the cover.

It is by the use of such aggressive and forceful ideas that many talking machine dealers are forging far ahead of their competitors.

A FORCEFUL ADVERTISEMENT.

In this week's issue of the Saturday Evening Post the Victor Talking Machine Co. is using a striking double-spread advertisement in colors devoted to the company's dance records. This advertisement, which is one of the most forceful pieces of talking machine copy presented in some time, is certain to attract considerable attention by reason of the human interest touch given it by the numerous dancing figures and its effective coloring. A few well-chosen paragraphs on Victor dance music and the formal announcement of the Victor Co.'s new book on "How to Dance the One-step, Hesitation and Tango" complete this excellent advertisement.

A hen doesn't quit scratching just because the worms are scarce.

BUILDING BUSINESS IN TEXAS.

Southwestern Talking Machine Co. Using Attractive Billboards and Other Means of Publicity to Bring the Columbia Line to the Attention of People in That Section.

The Southwestern Talking Machine Co., Dallas, Tex., Columbia distributor, is closing an excellent

publicity. Rafael Cabanas, president of the company, is a firm believer in the value of aggressive consistent publicity, and utilizes all forms of high-grade advertising to present the Columbia products most effectively.

The accompanying illustration depicts one of the company's numerous bill boards, which are scattered throughout its territory. This bill board is well conceived in every detail, and in its orig-



A Billboard That Has Attracted Attention.

business in its territory, which is due, in a considerable measure, to its up-to-the-minute

inal coloring made a striking display wherever it was put on exhibition.

5-CENT FILM OPERA GOAL OF EDISON.

Inventor Is Working Bigger Part of Every Day to Improve the "Talkie-Movies."

Thomas A. Edison, to whom life is a deadly bore when he isn't working nineteen or twenty hours a day, is said to be defying his doctor and his family again and toiling pretty nearly all the way around the clock. He admitted Monday that in the last week he had spent fewer than six hours in his home, Glenmont, at Llewellyn Park, N. J.

Every night and every day he has been busy in his laboratory in West Orange, only occasionally snatching a few hours' rest on a couch. He is trying to perfect the details of the "talkie-movie."

"Opera and drama for the poor workingman and his family for a nickel is what we should

have, and what we eventually will have," Mr. Edison said. "The moving picture, like the phonograph, has been a great educator. Children can see the pyramids of Egypt on the screen, and can hear the strange music of the Orient on the disc. Both of these things are now as perfect as they can be, but we should have the combination of picture and sound perfected."

The phonograph and the moving picture—because they have brightened so many lives—have always been Mr. Edison's favorites among all his inventions.

MINUS MEAT, BUT PLUS ENERGY.

F. K. Dolbeer Reports Great Physical Improvement After Year of Abstinence from Meat and Looks the Part—Enables Him to Work at Full Speed at All Times.

Just a year ago to-day F. K. Dolbeer, the well-known phonograph man, stopped eating meat. He might go on and make a great many comments about this, but the only real comment that is necessary is that he is a better man physically to-day than ever, and has an energy surplus that gets him up at 5 o'clock mornings and makes him sleep soundly nights. To say he works hard is superfluous, for everyone knows this. That he will work harder he knows, for the problems in connection with the exploitation of the Phonograph Co. in New York, both wholesale and retail, will consume a great deal of time. Mr. Dolbeer states that he will keep on his meatless diet, for, as he puts it, this policy is extremely valuable for health building.

HOLDS SERIES OF TANGO TEAS.

A. D. Matthews' Sons, Inc., the prominent Brooklyn department store, which recently opened an extensive Columbia department, has been holding a series of tango teas, which has been drawing crowded houses at every performance. The Columbia Colonial "Grand" has been featured at these recitals, and the adaptability of Columbia dance records to the proper dancing of the modern dances is well evidenced by the gratifying comments of all the visitors to these tango teas.

NO, HE DOESN'T MIND.

A salesman doesn't mind turning into a mere "order taker"—after he has created a desire for goods in his customer's heart.

LONG CABINETS

A New Cabinet for
Edison Disc Phonographs

Write for Circulars of
DISC RECORD CABINETS
and
PLAYER ROLL CABINETS

The Geo. A. Long Cabinet Co.

Address

Clement Becroft, Sales Manager

309 W. Susquehanna Avenue
PHILADELPHIA, PA.

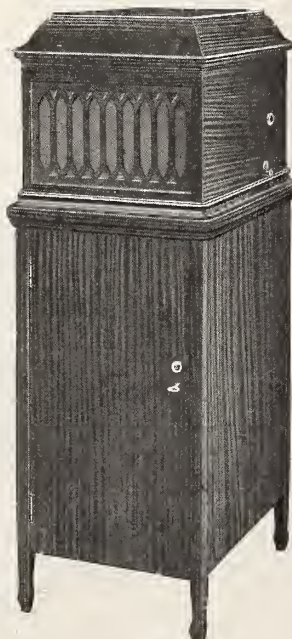

D 80

Mahogany, Golden Oak and Fumed
Finished all around.
For model A80
Edison Disc Phonograph.

NO UNCERTAINTY WITH "TALKERS."

Dealers in Talking Machines and Records in Los Angeles Among Few Business Men Doing Normal Business—Recent Trade Visitors—Southern California Music Co. Makes Change in Managers.

(Special to The Talking Machine World.)

LOS ANGELES, CAL., May 6.—April closed as a month of uncertainty in all general mercantile lines, except the talking machine line, which marks an era of exceptional vitality. The Mexican situation has caused uneasiness among merchants owing to the fact only that this section is so close to the so-called region of war and excitement. There is still a great shortage of Victor records, and dealers are hoping that their wants will be supplied in the near future by some mysterious means.

W. A. Manson, an enterprising Edison dealer of San Bernardino, Cal., was in Los Angeles for a couple of days and stated that prospects for future Edison disc and cylinder goods were very encouraging in his section.

J. W. Van Sant, of Raynard & Van Sant, Santa Monica, Cal., has recently sold his interests to his son and his former partner, W. J. Raynard. The firm will continue under the same name.

Barker Bros., 716-738 South Broadway, have very lately installed a complete line of Victor talking machines and records. F. C. Boothe, manager, states that wonderful returns have already come from this newly added line.

Ralph Paulin, who has been with the Gurnsey S. Brown Music Co., Santa Barbara, Cal., for many years, was in Los Angeles for a few days en route to the Imperial Valley, where he is very much interested in large land holdings in that rapid developing district.

The Eilers Music Co. is closing out its entire line of pianos, talking machines and musical merchandise and will discontinue the branch in this city.

One of the largest transactions in the musical line ever in the history of Los Angeles was recently completed when the Southern California Music Co. purchased and took over the entire stock of merchandise of the J. B. Brown Music Co., of this city. This not only increases the stock of the purchasing company, but gives it the agency for the Apollo player and other well-known pianos.

Chas. S. Ruggles, manager of Sherman, Clay & Co., of this city, reports the Victor distributing as doing unusually well considering the fact that the volume of business would have been much greater if it were not for the shortage in Victor records.

A number of changes has taken place within the past month at the Southern California Music Co. Jas. A. Stitt has taken over the managership of the

branch at San Diego, Cal. A. J. Morse, filling the same capacity in that city, becomes the head of the piano department here, and Geo. S. Marigold, first vice-president, has resigned and retired from active duties with the company. Fred E. Peterson resumes the duties of Mr. Marigold.

The Musical Record Co., 814 South Broadway, has added a complete line of Edison discs in connection with its large Victor stock.

The Victor department of the Geo. J. Birkel Co. has hit a high mark, according to the report of Manager A. Graham Cook.

A. C. Wisegarver, a prosperous Edison disc dealer of San Fernando, Cal., is scoring a big business.

Wm. Hobbs Richardson, department manager of the talking machine department of the Southern California Music Co., has left on an extended trip for several weeks, visiting New York and other Eastern cities. Mr. Richardson is accompanied by his wife.

INTERESTING RIEDEL CATALOG.

Noted German House Issues Volume in English That Is Invaluable to Talking Machine Men Who Need Supplies of All Kinds.

A very complete and striking catalog has been issued in English by Emil Riedel, of Chemnitz-Gablenz, Germany (P. O. Box 10). It covers a complete list of springs and a full line of supplies for talking machines. It is correct to a wonderful degree and shows a tremendous study of this particular field. This catalog also lists Riedel Patented Spring Winder, which is a necessary tool for every dealer in a repair shop. This machine is of unusual importance, being made in a practical way for universal use. This company also manufactures a complete line of stock springs, break-lever springs, screws and plates of various kinds. As for quality, the Riedel springs are made of Swedish clock spring style of the toughest quality, and a guarantee of quality and durability goes with each order.

REX CORPORATION IN WILMINGTON.

The Rex Talking Machine Corporation, of Philadelphia, has leased a building in Wilmington, Del., where it expects to locate within as short a time as it is practical to do so.

Philip Wohlstetter, general manager of this industry, advises The World that to secure a modern plant is in line with their policy, for they are rapidly making preparations for a seasonable autumn trade.

The man who insists on testing the silver lining of all his clouds deserves to get the acid in his eye occasionally.

PHONOGRAPH AS A BOOSTER.

Ad Club Quartet, of Los Angeles, Sings Booster Songs Into Edison Phonograph in Order that They May Be Circulated Among Advertising Organizations of the Country.

(Special to The Talking Machine World.)

LOS ANGELES, CAL., May 5.—A new local organization which has given its charm and peculiarity among music lovers is the Ad Club Quartet, which will leave Los Angeles June 1 for Toronto, Can., to attend the convention of the Associated Advertising Clubs of America. After leaving Toronto a general tour of the Eastern States will be made, and while in New York it will make records for one of the talking machine companies.

This unique quartet is composed of E. A.



Ad Club Quartet of Los Angeles.

Borgum, bass and banjo; Kenneth Wiseman, baritone and ukelele; Henry Hainert, first tenor and mandola, and Paul E. Adams, second tenor, guitar and piano. Mr. Borgum, the promoter of this club, has spent the last sixteen years in the talking machine business along the Pacific Coast. He is a live wire, and through him this organization has become very popular.

The Ad Club Quartet is carrying out a novel idea for advertising southern California, and all in a musical way. Many old song melodies have been set to new words by them and are often either in the form of an invitation to come to southern California or a brief description of the country's charms. Another novel feature of this quartet is their method of helping to teach and circulate their own songs so the public may quickly learn the words and melody, and that is by singing into an Edison phonograph to be recorded on a blank record. The result is that while the quartet itself cannot be in several places at the same time, the record speedily becomes circulated among all sorts of clubs, homes and civic organizations.

Many a man thinks he is full of ideas when he is simply full of talk.

The Silas E. Pearsall Company

Were first in the field as

Jobbers of Victor Products to believe in the Supremacy of the Victor

and are referred to as the house where VICTOR GOODS may be found when a shortage exists. Many dealers have been placed upon our books during the past strenuous six months.

Come in under our wing. We need you to help maintain Our Standard.

It will pay you to enter into correspondence.

SILAS E. PEARSALL COMPANY

VICTOR DISTRIBUTORS

18 West Forty-Sixth Street

(Near Fifth Avenue)

NEW YORK

We
Specialize
Foreign Records, Record Cabinets, Needles, Needle Cutters, Auto-stops, Corrugated Board Containers and Envelopes.

OUR MOTTO
Correctness and Despatch.

You Can Fill Every Machine With Colu

At \$25, at \$50, at \$75, at \$200—and all the way between and beyond—there is a Columbia instrument for everyone. Whatever style machine a man wants, whatever price he wants to pay, Columbia product will fill his want. The prestige behind and the demand beyond Columbia product make it a peculiarly profitable line for any dealer, and the profit to the seller and the satisfaction to the buyer on a \$25 instrument is as great in proportion as on a \$200 instrument.

If you don't yet carry Columbia Grafonolas and Colum you that a Columbia department will be *immediately* profitable because of the new and profitable sensations

For full particulars address: W

Columbia Graph

WOOLWORTH E

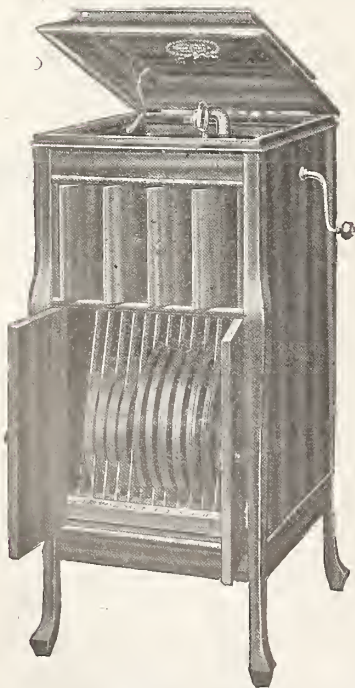

Leader, \$75



Eclipse, \$25



ant and Every Record Want a Product

From 65c. to \$7.50, there is a Columbia record for every demand. There are over 1000 65c. records—records retailing at 10c. less than any competitive record, yet carrying a larger percentage of profit on each record sold. Columbia dance records, endorsed by Vernon Castle are in greater demand than any other records made or sold. And all the way from One-step to Opera, the guaranteed tone quality and reproducing quality and endurance of Columbia records make a buyer every time the owner of a talking machine hears the first Columbia Record.

-Disc Records, why not? We are prepared to prove to you without extravagant investment and *continuously* e constantly springing in the talking machine field.

W. LYLE, General Manager

hone Company

NEW YORK



Favorite, \$50

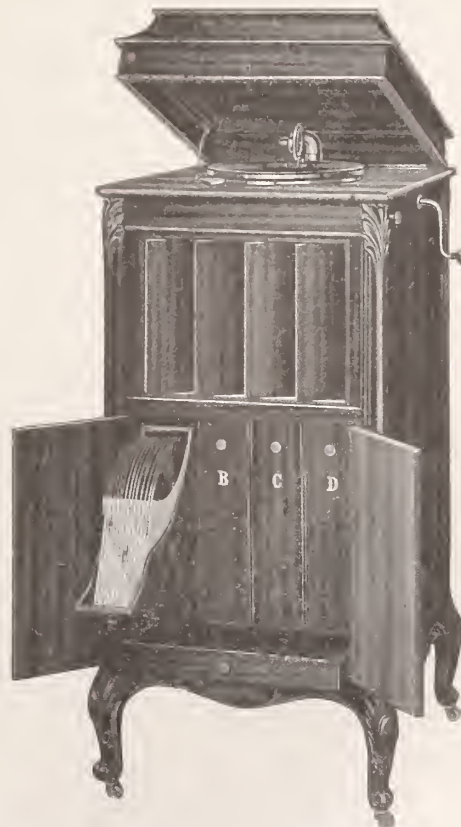

De Luxe, \$200

Notes



The more you realize that in the future of this industry, the best results are yet to come, the more freely you must admit that the Columbia is the line best worth the investment of your time, your energy, and your capital (Printing this every little while. Proving it all the time).



(Write for "Music Money," a book "full of meat" for those dealers interested in quick and frequent turnover of capital.)

Columbia Graphophone Company
Woolworth Building, New York

USES FOR WORN OUT WAX RECORDS.

May Serve to Take the Place of Paraffin for Many Purposes Especially in Electrical Work—May Be Handled as Solder.

That worn out phonograph records of the old style wax cylinder type, though of no value for the purpose of producing music, may still prove useful in another field is to be learned from the following contribution to the Technical World Magazine by a New Yorker with an experimental turn of mind, who says:

"When sealing up some windings, such as magnets, resistance coils, etc., and not having a sufficient quantity of wax or paraffin for the purpose, I made use of a few broken wax phonograph records. I was much surprised at the properties of this wax. In the first place, it was very hard compared with paraffin and had a rather high melting point, so that it would not soften and bend as paraffin, that is, it could not be made as flexible. I used this wax in constructing and repairing electrical instruments by coating the outer windings of the magnets, coils, etc., and then shaving down the wax. This looked exactly like hard rubber and had the advantage of being firmly fastened to the wire. I also used it in repairing broken magnet covers, filling the spots chipped out with the wax, with the result that it would take a close examination to detect the repair. Similarly it was used as insulation in constructing a one-inch coil, and although I could not test its dielectric

properties, I have had no trouble from leakage.

"This wax may be used for innumerable other purposes, as it can be melted and the article soaked in it, but it also can be handled in a more convenient manner, similar to soldering, by melting it with a piece of hot iron and applying it where needed, whereupon it is finished with a file and sandpaper, or turned in a lathe.

"The wax can be obtained from any dealer in phonographs, especially those keeping record exchanges. Be sure to get the wax records, not the indestructible ones made of vulcanized composition, as these will not melt. Various colors may be had, but black resembles hard rubber and gives a better appearance. The final finish may be done by polishing with a little benzine on a rag."

ORDINANCE AGAINST FAKE ADS.

Text in Full of the Ordinance Against Misleading Advertising Recently Passed by the Board of Aldermen of New York City.

Following the receipt of several inquiries from the trade regarding the recent ordinance passed by the aldermen of New York City against fraudulent advertising, we herewith reproduce the text of the ordinance in full.

The ordinance, as passed by the board, is as follows: "Any person, firm, corporation, or association who, with intent to sell or in any wise dispose of merchandise, securities, service, or any thing offered, directly or indirectly, by such person, firm, corporation or association to the public for sale or distribution, or with intent to increase the consumption thereof, or induce the public in any manner to enter into any obligation relating thereto, or to acquire the title thereto, or any interest therein, makes, publishes, disseminates, circulates, or places before the public, or causes directly or indirectly to be made, published, disseminated, circulated, or placed before the public in this city in any newspaper or other publication sold or offered for sale upon any public street, sidewalk, or other public place, or on any sign upon any street, sidewalk or public ground, or in any handbill or advertisement posted upon any street, sidewalk or public ground, or on any placard, advertisement, or handbill exhibited or carried in any street or public ground, or upon any sidewalk, or on any banner or sign flying across the street or from any house an advertisement of any sort regarding merchandise, securities, service, or anything so offered to the public which advertisement contains assertion, representation or statement which is untrue, deceptive or misleading, shall be fined not less than twenty-five (\$25) dollars nor more than two hundred and fifty (\$250) dollars, or by imprisonment not to exceed six months or by both such fine and imprisonment."

MANAGER OF GRAFONOLA SHOP.

August Bowers, formerly manager of the talking machine department of Bloomingdale Bros., Fifty-ninth street and Third avenue, New York, has been appointed manager of the Grafonola Shop, 143 West 125th street, the new Columbia representative, which was formally opened last week.

PROFITABLE AS A SIDE LINE.

Are the Vacuum Cleaners Made by the Regina Co.—Models Appeal to All Classes Owing to Their Variety and Their Prices.

Quite a few talking machine dealers have seized the opportunity to add to their profits by selling vacuum cleaners, which, by the way, are now being recognized as the most efficient way of keeping the home clean. Those who have handled these goods, particularly those who have featured the Regina products, report a profitable business that is constantly growing—a business that bids fair to make a remarkable showing in the course of a year.

Among the styles of vacuum cleaners made by the Regina Co., 47 West Thirty-fourth street (Marbridge building), New York, is electric model "C," which is the result of long and careful experimenting by competent engineers, and is capable of producing a greater vacuum and larger air displacement than can be obtained from any machine of its type. It is mounted on rubber-tired wheels; is powerful enough to remove not only

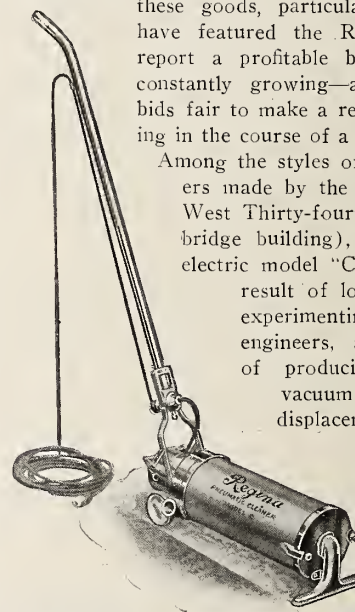

Electric Regina, Model C.

dust, but germs as well, and costs about one cent per hour to operate.

Then there is the Regina vacuum sweeper, model "J," which is a combined carpet sweeper



Regina Sweeper, Model J.

and vacuum cleaner, very easy to handle. A strong suction is produced by three bellows, while the sweeper is in motion on the floor in either direction. When desired, a hose and tools can be furnished for cleaning upholstered furniture, mattresses, curtains, etc.

All the Regina models constitute a line of vacuum cleaners suitable for all purposes—a line that includes high-grade machines at a price within the reach of those of modest means and of a quality to satisfy those who demand the best.

For Sale

8,000 10-inch single face records—Italian, French, Columbia, Zonophone and Spanish. Brand new clean stock at 8c. each. Fifty disc talking machines, all different makes, in good condition, which came in exchange, must be disposed of at any price. About 800 horns, fit the Columbia or any make, with a screw on the bottom size, 45 centimeter Red and Blue brand new in crates at 15c. each. Address "Records," care Talking Machine World, 373 Fourth avenue, New York.

For Sale

Talking machine business in live growing Southern California city of 15,000; fine country surrounds; practically no competition. Stock and fixtures will invoice about \$3,000. Have Victor, Edison Disc and Cylinder agencies. Don't answer unless you have the money. Address "Chance," care The Talking Machine World, 373 Fourth Ave., New York.

FOR SALE

The only music store in growing city of over 50,000 in Northern Ohio, with long lease; old established business, centrally located; complete but clean stock, including Victor and Columbia agencies; excellent reason for selling; great opportunity for right party. Address Mrs. H. E. P., care The Talking Machine World, 373 Fourth Ave., New York.

VICTOR BOOK ON POPULAR DANCES.

"Three Modern Dances" Contains, Among Other Features, Reproductions from Motion Pictures of Leading Dances as Posed for by Mr. and Mrs. Vernon Castle.

The Victor Talking Machine Co., with its customary aggressiveness and dealer co-operation, sent out to its trade recently a most valuable publication entitled "Three Modern Dances." This book illustrates by the means of moving pictures the one-step, hesitation and tango, the three popular dances of the modern dance series. These moving pictures were all posed by Mr. and Mrs. Vernon Castle, the most successful exponents of the present day dances, who supervise the production of all Victor dance records.

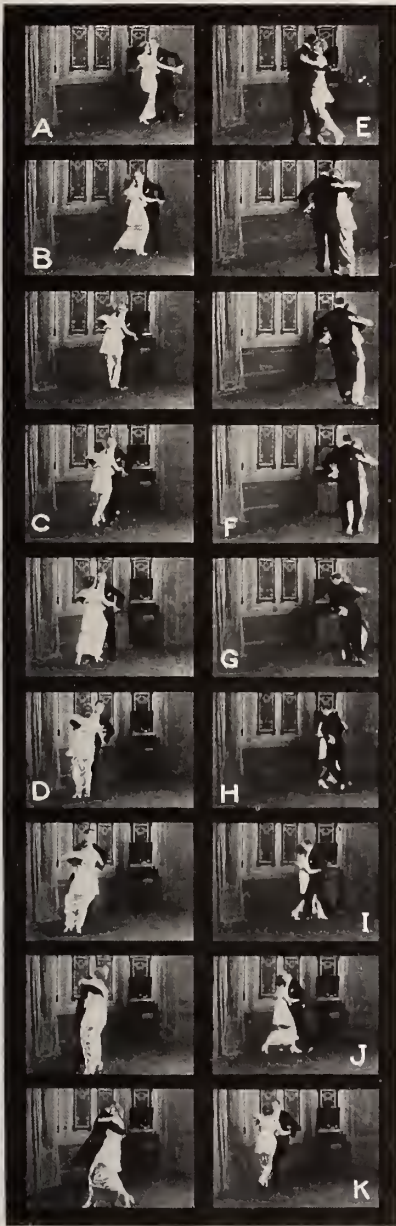

Illustration from Victor Dance Book.

The detailed moving pictures of these three dances are remarkably clear and distinct, giving simple instructions that will help the beginner to learn all the dances when used in conjunction with the rhythm and tempo of Victor dance records. The value to the dealer of this new book is incalculable, as he can undoubtedly use it as a medium for attracting new trade to his establishment, in addition to its use as a means for selling the latest dance records to his present customers.

The fame and prestige of Mr. and Mrs. Vernon Castle give a weight and influence to this Victor publication that will give it a ready entree in the homes of the most enthusiastic lovers of the modern dances, as every dance is shown step by step through its various formations. Five different styles of the one-step, five hesitation waltz steps and six different versions of the popular tango are all illustrated in this dance publication, affording a wide range of steps for all dance lovers.

The supply of these new books is limited, and the company suggests that Victor dealers distribute them discriminately, making the presenta-

tion of each book a personal matter, and asking the customer to visit the store for an individual copy.

The Victor Co. is to be congratulated on the high-class and dignified appearance of its latest aid to Victor dealers, as every page is typical of the high-grade character of all Victor publicity.

"STANDARD RECORD CLEANER"

Recently Placed on the Market by The Standard Gramophone Appliance Co., Is Winning a Large Measure of Favor in the Trade.

The Standard Gramophone Appliance Co., 173 Lafayette street, New York, placed on the market this month a cleaner for disc talking machine records which is officially designated as the "Standard Record Cleaner." Although this new cleaner has been on the market but a very short while, it has already won the general praise of the company's trade because of its numerous merits.

In a letter to the trade announcing the advent of this cleaner the company called attention to the fact that the device is fully protected by United States patent. The letter also remarks as follows: "Kindly pass this cleaner over a record; note how it automatically tends to grip and stay on the record, much as if it ran on rails. This highly desired result is due to the shape of the cleaning surface. Also note that the carpet area is sufficient to cover all lines of the record, first to last, the result being that one or two times around the record cleans it perfectly." The cleaner is made up very attractively and is designed to retail at 50 cents. The company is making an offer to the trade whereby responsible dealers may receive a sample cleaner on receipt of 10 cents.

In introducing this "Standard" record cleaner the Standard Gramophone Appliance Co. is adding to its already comprehensive line a valuable accessory which will doubtless be equally as successful as the well-known "Standard" automatic stop and the "Standard" fiber needle cutter which have achieved country-wide popularity. Both of these products are meeting with a ready sale from coast to coast and their perfected construction and practicability have been responsible for many testimonials that the company and dealers handling the devices have received from time to time.

The success of the company's various products can be attributed in a considerable measure to the careful supervision which is bestowed on every single device that is turned out of the plant, as Thomas W. Kirkman, general manager of the company, is a practical mechanical engineer, who personally directs the manufacturing end of the business.

PHONOGRAPH PROVES A SURPRISE.

Professor Jepson, of New Haven, Supervisor of Music, Enthusiastic Over Reproduction of Edison Disc Phonograph at Chamber of Commerce Luncheon in That City.

Professor B. Jepson, for many years supervisor of music in the public schools of New Haven, Conn. (and now supervisor emeritus), recently attended a luncheon at Hotel Taft, that city, given by the Chamber of Commerce. At the conclusion of the repast an Edison disc phonograph did the entertaining. The professor, who had never heard the Edison disc, thus expresses his surprise and delight:

"I must confess I was never more taken back in my life. A beautiful soprano voice launched into a solo. I was not surprised at that, but very much surprised as I looked around the room in vain for the soloist. I supposed, of course, that I would find the lady in the center of a group of men gathered in the rear of the room. I was greatly astonished to find that the beautiful voice emanated from a phonograph. To sum it all up I must say that Edison's new Diamond Disc is the 'last word' in the rendition of vocal or instrumental music."

Professor Jepson's opinion in musical matters is regarded with the highest respect. For over fifty years he has directed the musical functions and destinies of the New Haven schools, and stands high in the musical world.

How To Make Dollars

Yes, and how to make them grow with a comparatively small outlay of time and money.

That topic ought to interest you, Mr. Talking Machine Dealer!

Just figure how admirably you could work in pianos with your present line.

By pianos we mean those which are called both straight and player-pianos—in fact, every member of the piano family, including grands; but the main thing is to get your instruments right. In other words, at values which insure you liberal profits.

We have helped many a piano merchant to become a successful business man, because we have given him values which were not obtainable elsewhere, and we can help you. We can help you to show profits which will be particularly pleasing.

We would suggest that you do not delay an investigation of this matter, but take it up to-day—right now.

Don't waste your most valuable asset—time—by delaying too long!

H. P. NELSON COMPANY

Makers of Grands, Uprights and
Player-Pianos

North Kedzie, North Sawyer, West Chicago Aves.
and C., M. and St. Paul R. R., CHICAGO.

FROM OUR CHICAGO HEADQUARTERS

E. P. VAN HARLINGEN, Manager
HENRY S. KINGWILL, Associate

World Office
Consumers' Bldg., 220 South State St., Chicago
Telephone: Wabash 5774

(Special to The Talking Machine World.)

CHICAGO, ILL., May 9.—What should be a most careful bit of information to the talking machine trade is found in the report issued May 7 by the Department of Agriculture.

Uncle Sam's experts promise that 1914 will produce the largest crop of winter wheat ever grown, even exceeding by one-fifth the record yield of 1913. The wheat belt has been visited by a large amount of rainfall and the soil has been so thoroughly soaked that a yield of 630,000,000 bushels has been promised. We of the Middle West find much that is pleasant in the fact that Kansas will grow 132,000,000 bushels; that Nebraska will grow 63,000,000 bushels, and that Indiana, Illinois, Michigan, Ohio and Missouri have nearly perfect prospects. With this tremendous amount of wheat and the correspondingly good crops in other grains, 1914 should be a record breaking year in the sale of talking machines and records. Let us hope that every farmer in the Mississippi Valley will see fit to invest a little of the money that these crops will bring in a fine talking machine and a good library of records.

Present conditions in the local trade indicate that the major part of the business being done is in records of the popular sort, with an especially heavy call for dance records. A let-up in the dancing craze has been predicted by numerous people for a long time, but the immense sales of dance records have made it clear to the talking machine dealers that there is more strength behind this revival of the love of dancing than anyone thought. There seems to be a decided leaning by talking machine buyers toward machines running about \$100 in price. The more expensive machines also are enjoying a good demand. There is rather a lull in talking machine sales generally as compared with the past few months, though a comparison with April and May of last year shows an improvement.

"Start Them Off Right."

H. H. Schwenker, expert repair man from the Victor Co.'s factories, is on a trip through this territory instructing dealers in the art of repairing machines and keeping them in adjustment. "The problems with which I come in contact," said Mr. Schwenker, "are almost invariably different, but if I were asked what maxim I would suggest to the dealer I would say 'start the machines off right when you sell them,' that is, when

a machine leaves the dealer's hands it should be in perfect condition. In all probability he will have no further trouble. If the machine goes out, however, with some slight trouble, it is probable that the buyer, who knows nothing of machinery, will endeavor to fix it himself and does more harm than good. No matter how carefully packed, a talking machine is liable to suffer some little damage in transit, and the dealer should, upon receipt of machines, clean them, oil them and see that the adjustment is correct. The dealer should also be sure that he himself understands the mechanism of the machines which he sells."

Columbia Retail Growing.

Charles F. Baer, local manager of the Columbia Graphophone Co., reports that a most pleasing feature of the company's local business is that of the retail store on the first floor of the Ward building. This department has shown a steady increase every month since it was started, and the prospects for the continuance of the increase are of the brightest kind. The "De Luxe" style has been practically sold out in both the wholesale and retail departments, and steps are being taken to avoid the inability to deliver these machines. Other styles running around the \$100 mark are also in great demand. Columbia dance records continue to enjoy a tremendous sale and "Puppen" continues to lead in this direction. The complete revised catalog of foreign records has just been received and it is being used to great advantage by dealers all over the country. A big demand is also being met with on the new booklet on dancing entitled "How to Dance the Modern Dances," by G. Hepburn Wilson, who supervises the making of all Columbia dance records. These booklets are being furnished gratis to all Columbia dealers, who are receiving big demands for them. District Manager W. C. Fuhri announces that General Manager Geo. W. Lyle is expected to arrive here from New York about May 15.

John P. Byrne Dead.

John P. Byrne, one of the pioneers of the musical department business and at one time vice-president and treasurer of Lyon & Healy, died yesterday afternoon at his residence following a long illness. Mr. Byrne was sixty years of age and spent the greater part of his life in the music trade. Mr. Byrne is well known to the talking machine trade and the news of his loss will be received with great regret.

Big Call for New Style Victrola.

R. J. Keith, sales manager of the Talking Machine Co., announces that he is receiving a large advance demand on the new style Type F Victrola XI, which will make its appearance in a week or two. This style is about an inch larger all around than the preceding styles and which is made with an interior arrangement of eight shelves, each holding eighteen records and lying flat. This arrangement can be changed to receive records vertically. A number of dealers, Mr. Keith says, have ordered liberally for their fall stocks to insure deliveries when wanted.

Mr. Keith in a recent trip to Indianapolis aided in the installation of a fine up-to-the-minute Victor department in the large department store of the Pettis Dry Goods Co. The booths are remarkably soundproof; are constructed of solid mahogany and fitted up beautifully. Elmer Gay is the manager.

Mr. Keith also aided in the installation of a new Victor store at Kenosha, Wis., for O'Shea & Biddinger.

Dan Creed, credit manager of the Talking Machine Co., is spending two weeks at French Lick Springs recuperating from a long season of hard work.

Personals and Visitors.

Frances E. Clark, head of the educational department of the Victor Talking Machine Co., was in Chicago a few days on her way to Minneapolis, where she will attend a convention at which she will make an address.

William H. Richardson, manager of the Southern California Music Co., of Los Angeles, was a recent visitor to Chicago. Mr. Richardson is an old music trade man and has been connected with this house for a long time. He reports that although business lately on the Coast has not been all that could be desired, nevertheless a decided improvement is beginning to make itself felt. Mr. Richardson will visit the principal cities of the East, stopping at the Victor, Columbia and Edison factories.

N. Wurth, Escanaba, Mich., and W. & J. W. Sproesser, of Watertown, Wis., were visitors to the local trade this week. Mr. Wurth handles the Columbia goods exclusively.

R. W. Smith is a new Illinois traveler for Lyon & Healy, succeeding L. C. Cummings, who is to be married shortly. Mr. Smith has also a number of Iowa river towns.

S. M. Field, formerly floor manager of the Chi-

(Continued on page 38.)

THE WADE—THE PRACTICAL—THE WADE Fibre Needle Cutter

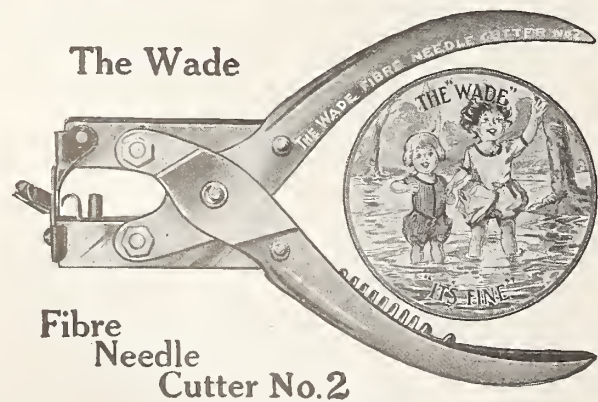

The Wade

Fibre
Needle
Cutter No. 2

The WADE embodies the *right principle*, worked out through *long experience*. It is simple, durable and accurate. It trims the needle at an angle resulting in the best tone.

The WADE cutters are made of the best steel and are absolutely guaranteed.

The WADE is the most economical cutter. It has a self-acting stop, which prevents waste and enables one to get from 12 to 15 perfect playing points. No. 2 has a double action, making it especially easy to operate and affording the most powerful cut of any tool made. No. 1 is a very popular cutter which has given excellent service.

RETAIL PRICES—No. 1, \$1.50; No. 2, \$2.00

Order from your regular Distributor—we sell to Jobbers only

WADE & WADE,

3807 Lake Ave.
PHONE, DOUGLAS 8108
CHICAGO, ILL.

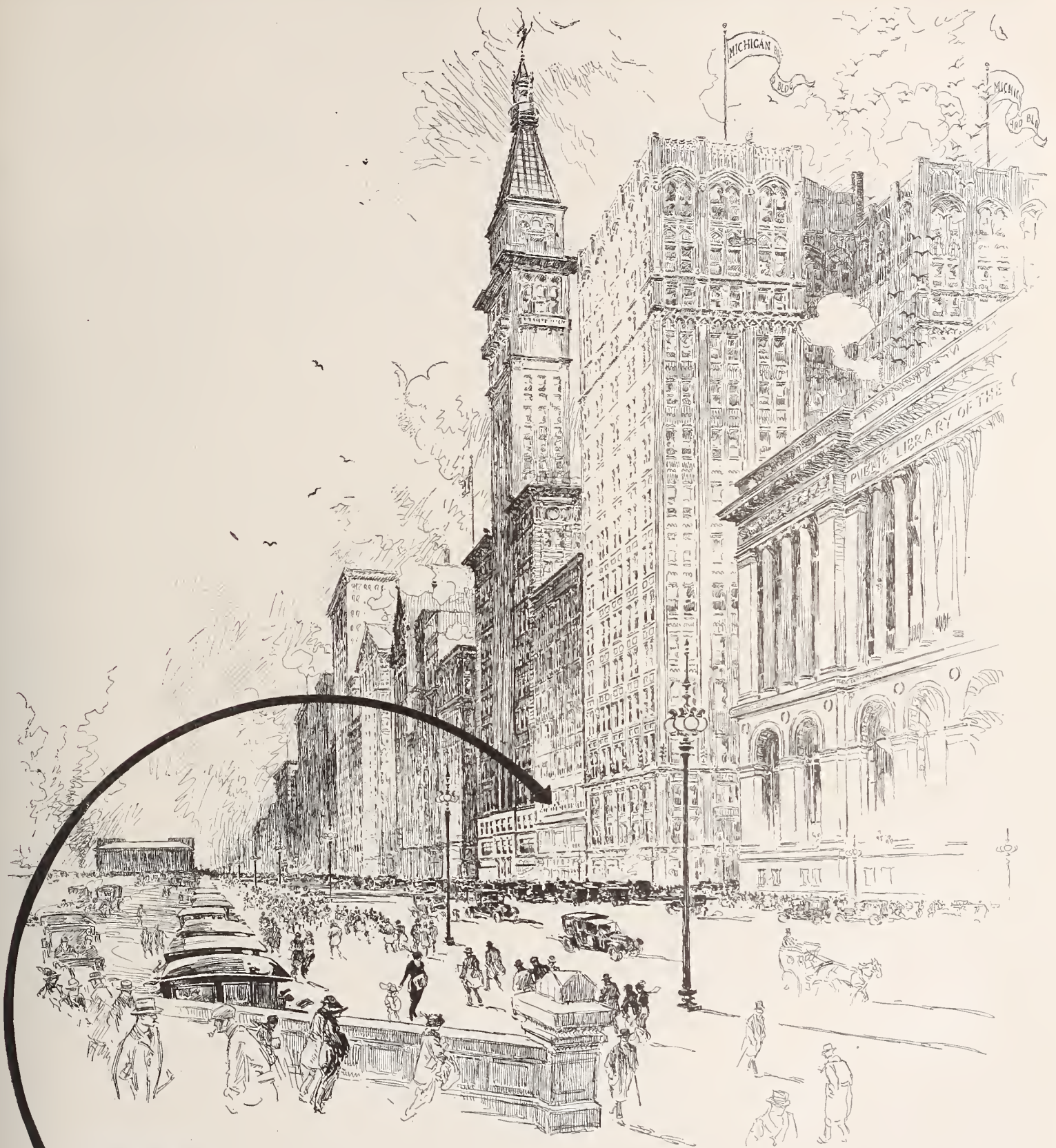

COPYRIGHT · 1914
CHARLES DANIEL PREY

A Good Looking Sky Line

OUR location excellent, isn't it?

140 feet on Michigan Boulevard — Plenty of Air and Light — all this makes for Service.

Our business has been developed into the **Largest Exclusive Victor Distributing Business in the World** — all on that one word — **SERVICE** —

You'll find we'll Make Good.

THE TALKING MACHINE COMPANY
12 North Michigan Avenue : : : : Chicago

FROM OUR CHICAGO HEADQUARTERS—(Continued from page 36).

Chicago Columbia store, was a recent visitor to Chicago. Mr. Field was lately appointed manager of the Grafonola department of the Gus Blass Dry Goods Co. at Little Rock, Ark.

Don C. Preston, traveler for the Talking Machine Co., who was recently married, spent a few days of his honeymoon in Chicago. Mrs. Preston is now accompanying her husband on a trip through the northern part of his territory, which includes Minnesota and Wisconsin.

Mr. Stewart, of the Stewart Bros. Furniture Co., of Columbus, O., was a recent visitor.

Lew Collins, manager of the contract department of the Victor Talking Machine Co., was a visitor for a few days to this section.

B. F. Dvorak is once more with the retail department of Rothschild & Co.

To Make a Fibre Needle, Also.

Louis K. Scotford, president of the Cleartone Talking Machine Co., 32 South Clinton street, announces that his company will not only manufacture the pneumatic turntable disc which it manufactures and which was recently described in *The Review*, but it will also manufacture an improved fibre needle, which has been prepared in such a manner as to greatly increase its durability by making it possible for each needle to be used four or five times without repointing. It is probable that the company will also handle additional talking machine accessories. The factory on South Clinton street is being rapidly put into shape and a large volume of the company's product will be turned out within the next month. The officers of the company are: Louis K. Scotford, president; M. L. Willard, vice-president; Arthur F. Agnew, secretary, and George A. McGriff, treasurer.

George Ade Delivers Speech

W. W. Parsons, manager of the Dictaphone department of the Columbia Co., made arrangements to-day whereby George Ade, the famous humorist and playwright, will deliver a speech to his fraternity brothers assembled in convention at Cleveland next week through the medium of the Dictaphone. After giving his talk into the Dictaphone, the record will be shipped to the committee in charge of the arrangements at Cleveland and the speech will in turn be delivered with the aid of a large horn. It is expected that 300 or 400 members will be in attendance and will have the opportunity of hearing very clearly every word that is spoken by Mr. Ade. Although an uncommon occurrence, this has been done before, and it is related that an octogenarian college professor once delivered a speech in this way to his former pupils, gray haired men themselves, who when they heard the voice of their old mentor remarked with tears in their eyes, "Isn't that just like him?" and "He hasn't changed a bit."

Lyon & Healy Start Children's Hour.

Lyon & Healy have started "The Children's Hour," a period of from 10 to 12 o'clock on Saturday mornings when the little sons and daughters of Lyon & Healy's patrons and the general public are entertained through the medium of the Victrola. The abundance of the Victor records listed under the caption of "Educational Series" gives a wonderful opportunity to instruct as well as to entertain the children and they will also be given an opportunity of hearing the beautiful standard works of musical art in such a way as to aid in the development of their musical sense. Miss Elsie Stein has been placed in charge of this work and explains the records to the children as they are played.

Manager L. C. Wiswell announces that Lyon & Healy business continues to be good and that May shows a decided increase over May of last year. "Machines around \$100 are selling very good," said Mr. Wiswell, "and in the record department those of the dance variety continue to be the big sellers. 'Cecile' leads, I believe, and all of the Castle House Orchestra records are going well."

Shop Presents the Castles.

The Talking Machine Shop scored another big hit when Mr. and Mrs. Vernon Castle were exhibited to a throng of enthusiastic admirers last week. The famous dancer and his very pretty

and equally capable dancing wife were introduced to visitors to the shop just before they took part in a matinee performance at Orchestra Hall. At this performance there was a dancing contest for the Castle cup, the winner of which was engaged by the management of the shop to dance all week. Mr. Castle gave a few instructions for dancing, dwelt on what not to do, and spoke of the excellency of the Victor dance records which he supervises. The winners of the contest were Mr. Youngs and Miss Hill, and they are dancing all this week and continuing to make publicity and friends for the shop and its management.

Klingsor Recital Soon.

The Klingsor Talking Machine Co. will give its introductory recital and demonstration within a week or two, according to a statement made by officers to-day. The line is being photographed and prepared for exploitation by July 1.

Great Singer Some Day.

The little girl born to George W. Davidson, of the Talking Machine Shop, last month is doing nicely, as well as her mother. The young lady gives promise of some day being a great singer, and no doubt her proud father will at some future time sell Red Seal records of her voice.

C. L. BYERS ADDRESSES CHICAGO BOARD OF ADVERTISING.

Retail Sales Manager of Columbia Graphophone Co. Gives Interesting Talk on Salesmanship and Has Something to Say Regarding the Progress of the Talking Machine.

(Special to The Talking Machine World.)

CHICAGO, ILL., May 7.—An interesting little talk was delivered by C. L. Byers, retail sales manager of the Columbia Co.'s store, Chicago, before the Board of Advertising, which consists of almost 200 advertising men and sales managers of Chicago concerns—at one of its recent meetings.

Mr. Byers, in his preliminary remarks, stated that salesmanship was a subject worthy of deep study, scientific investigation and philosophical speculation—that there was no vocation of man so comprehensive in its demand on all of the available elements of the entire being.

He discussed the evolution of the talking machine from the days when it was merely a toy to its present position in the musical world, where it has assumed a position of overwhelming importance, and said: "The talking machine to-day is truly entitled to be classed as a necessity just as much so as your newspaper, your magazine or your telephone. Its double educational and entertaining features make it indispensable in every home. I am sure you will admit that a home without music is a home without soul. Can you conceive of a more versatile, useful or reasonable priced musical instrument to-day than the talking machine?" He emphasized how the one-price system in vogue in the talking machine field was a boon to the merchant, and said: "While it does not eliminate competition between dealers of different lines, it does remove all possibility of the cut-throat competition between dealers of the same line. It also stimulates a splendid co-operative spirit among the dealers, each feeling that the interests of one is the interest of all."

Mr. Byers then proceeded to discuss the principal matter at issue, as follows:

Retail Selling of a Grafonola

To begin with, I will give you some idea of what is necessary in a successful Grafonola salesman.

First. Versatility—There is no business in which you are required to deal with every strata of society more than in the selling of the talking machine. One must have a personality of a chameleon nature. It must be able to harmonize quickly with every type of human character if it would be successful; for in our business you are not dealing with a particular class, but with every class. The rich and the poor, the ignorant and the learned, and the American and the foreigner. This versatility can be cultivated, it is not necessarily innate.

Some people think success in life depends upon circumstances, or upon chances. It is not to be denied that these things have their influence, and yet nine times out of ten, the men who win have cultivated qualities which have brought them their success and those who lose, have simply neglected this cultivation. Ninety-nine out of a hundred, who fail, could have succeeded if they had used their opportunities aright. And so the qualities which blend into versatility can surely be cultivated.

Second. Industry—A polite word for hard work. No profession is more responsive to hard work than salesmanship. And the measure of responsiveness is especially noticeable in the talking machine business.

Work is a word so comprehensive in its meaning

that the most indolent finds shelter in some technical sense of its use. But my conception of work is a real red-blooded, energetic, enthusiastic use of the mind and body to the end that definite results may be accomplished. This is the kind of industry that succeeds in the talking machine business. We have no fixed hours, our time being controlled entirely by the exigencies of the business. In fact, a real wide awake talking machine salesman sacrifices many an evening's pleasure in order that he may make a call and thus close a sale that might otherwise be lost. It is a peculiar fact that when a musical instrument is to be purchased the whole family buys it, and unless you make a call in the evening, when you can concentrate your versatility on the whole family, your chance of closing a deal is often lost. It is usually necessary to convince the parents that the spiritual life of the home cannot be better conserved than by one of these instruments with the beautiful sacred selections; and Amy, a blue-eyed beauty must be convinced that her tango and maxixe can be wonderfully improved with your instruments; and then too, wee Willie, though but a ruffle-haired boy, who usually must be seen and not heard, is a real important member of the board of strategy when a talking machine is to be purchased. He too must know that his cultivated taste for good music can be pampered by one of your instruments and your classic records, such as the Dill Pickle Rag, the International Rag or the Raggedy Rag. Then in order to make your work easier and your heart lighter, your prospective customer invites a number of his neighbors in to help decide the matter. In this manner you are the victim of soirees, and Kaffeeklatsches, whether you choose to be or not. Yet as an industrious patient and long-suffering salesman, you wait the time when with a real vengeance you get the name on the dotted line. Here is a real test for your versatility. This will either make a diplomat or a diplomaniac out of you.

In our business, sales are truly commensurate to the industry of the salesman.

Third. It takes a thorough knowledge of the business. The very first preparation of a salesman in any business is to familiarize himself with that business. Not merely the manufacture and merit of the goods, but every branch of the business, the policy of the firm, the advertising plans, the selling plans and the various methods of promoting and developing the market for the goods. After all the salesman is the firm incarnate in an individual. The better equipped the individual, the better represented is the firm. Though a man be a caddy, he should increase his efficiency by a thorough knowledge of golf. No work you engage in is so unimportant that it is unworthy of your study and investigation. Like the great Epaminondos of old, when elected garbage collector of the city, by his enemies accepted, and said: "If the position reflects no honor on me, I will reflect honor upon it." In our business, knowledge of the business is truly a great factor.

I have found in my experience that a salesman equipped with versatility, industry and a knowledge of his business has the three big elements that make for success.

(Continued on page 40.)

ABSOLUTELY NEW
Everlasting Dustless Record Cleaner

PATENT APPLIED FOR



FRONT VIEW

The Everlasting Dustless Record Cleaner is made of the finest grade of carefully selected wool skin with the wool cut short.

It polishes, cleans and prolongs the life of records. Makes them look like new. It positively cannot scratch or mar records in any way, and can be cleaned with benzine, gasoline or cleaner preparation.

Retails for 15 cents. Write us to-day.

Sold to dealers in dozen lots only.

\$1.25 per dozen

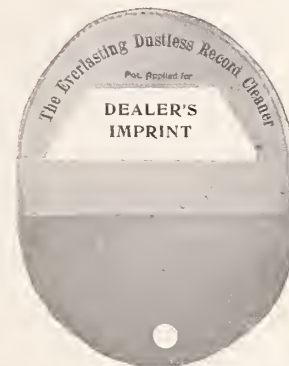

BACK VIEW

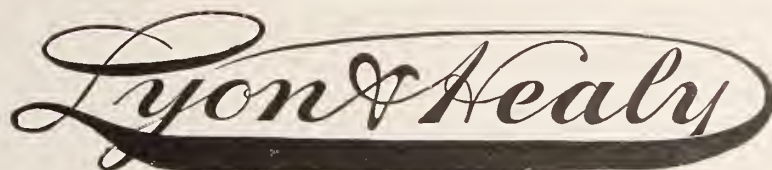

FIBRE NEEDLE CUTTER

**OVER
 50,000
 SATISFIED
 USERS**

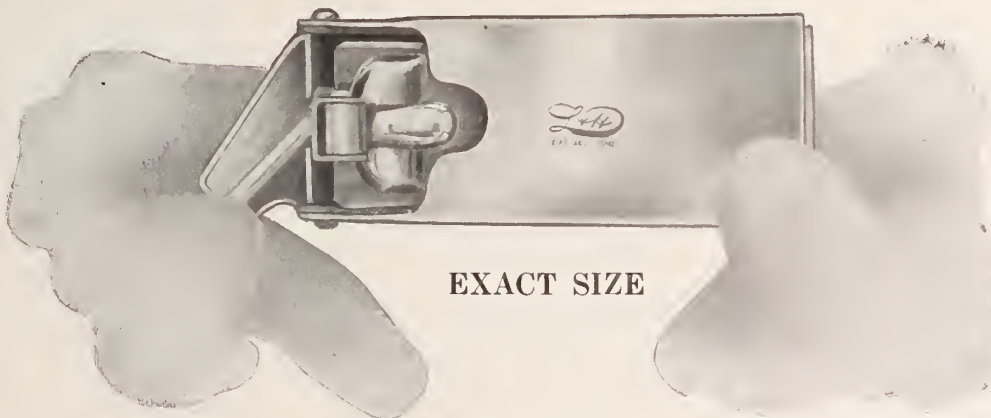

EXACT SIZE

You can order through your Jobber. He will supply you; if not, send your order to us.

The wonderful success of the Lyon & Healy Fibre Needle Cutter in the last two and a half years is due to the following facts about the cutter:

The Blades of the Lyon & Healy Fibre Needle Cutter are made of the finest grade of properly tempered tool steel. The upper blade is pivoted above and back of the cutting edge of the lower blade. It is held in place by a very high tensioned spring to insure correct leverage and a perfect point at every cutting.

The cutter is fitted with a guide that prevents the cutting away of too much of the needle, and also has a receptacle that receives all the waste. It is very simple and easy to operate, and with ordinary usage should last indefinitely without sharpening.

This cutter is invaluable to all users of the Fibre needle, as a needle may be used twelve to fifteen times where one of the cutters is in use.

Now is the time to get your order in and share in the profits.

Retail Price \$1.50

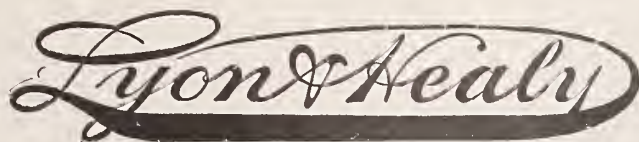

CHICAGO

Largest Victor Distributors

**SEND US
 YOUR
 ORDER
 TODAY**

**LIBERAL
 DISCOUNT
 TO THE
 TRADE**

FROM OUR CHICAGO HEADQUARTERS—(Continued from page 38).

The retailing of the Grafonola is done in two ways. In the store or outside of the store. With a well-organized sales force, as much is sold outside the store as in it.

The inside salesman takes the name and address of each customer to whom he has demonstrated but not sold an instrument, and turns it over to the prospect department. In addition to the name and address, he gives full information concerning the instrument which the prospect seemed most interested in, and above all, gives any information he has acquired concerning the nationality, personality or peculiarity of the prospect.

A card containing all of this data is given to the outside salesman as a lead, and is followed up systematically by the retail sales manager.

The detailed information is valuable assistance to the salesman, as it forearms him with the necessary intelligence of the customer's personality. The securing of this information concerning the customers, who seem only slightly interested is very important, since I have found very often that the tiniest nibble often proves the biggest fish.

In passing, I might say also, that the distribution of the prospects is the opportunity for the retail salesmanager to use his ability. If he is alive to every situation he has studied the respective abilities of his outside men, and is guided largely by this in the distribution.

Salary and commission is our plan of compensation. The salary to maintain a mutual and reciprocal sense of obligation as to hours, system, co-operation and duty. The commission to render the compensation fair and just and in exact accordance with the work and results of the salesman. I am heartily in favor of commission to sales people. I contend that on an exclusive salary basis one of two things exist. The salesman is either getting more than he is worth, or he is getting less than he is worth. Commission establishes an equilibrium in the compensation. It is especially successful in our line, since a good proportion of our sales are closed at night, and unless the compensation for each sale is worth while, the salesman, for lack of an incentive, will neglect the night calls and thus curtail the sales of the firm as well as his own.

The store and its arrangement is a great subject in itself, and one that cannot get too much consideration. Time will not permit me to dwell on this, but suffice it to say that the store must be nicely furnished and kept immaculately clean, especially where it is catering to the best people. The goods must be arranged with the element of human appeal in mind. Remember always the merchandise is primarily to sell, and secondarily to exhibit, and that the latter is merely the means to the end.

The window display surely comes very close to the advertising man. This is the place to work in the individuality of your sales manager. Here is where originality should play a prominent role. I make it a rule at our store to change the windows

completely once a week. All signs are made and outlined to harmonize with the display or season. The window to-day is considered the reflector of the store. It bespeaks the quality of your goods. It should be a forceful invitation to the passer-by to come in. There is a growing appreciation of the window as a very important part of a store's advertising, and a big asset to the business.

To close I want to call your attention to an element that has done more than anything else to make our sales continually increase: that is enthusiasm. It means to do what you do with all your might, it means to be "red-hot," in earnest, or enthusiastic in what you do. When a man is talking an article of merit, and he has no business talking any other kind, enthusiasm is necessary. One can feign enthusiasm, but it is not genuine. Enthusiasm that is not felt is false fire, but when it comes from the heart it accomplishes great things.

In the fields of salesmanship and advertising we have need of an all-consuming, fiery spirit of enthusiasm, and I am sure that the advertising men and the salesmen of this twentieth century, prompted by such a spirit, will blaze a path through the industrial world, solving all commercial problems, developing the best and crushing the worst in all business enterprises, and above all, rendering man a ruler over his commercial destinies, rather than a victim.

WILL SELL TALKING MACHINES.

(Special to The Talking Machine World.)

CHICAGO, ILL., May 11.—The management of the new \$8,000,000 mail order house of Lundin & Co. informs us that they will have a complete department of talking machines, pianos and accessories. The management referred inquiries as to the details to R. B. Handley, the new buyer for this department, but he was absent from the store for the day.

The new mail order house of Lundin & Co. is a combination of several concerns, of which the only ones at present made public are Lundin & Co., at present in the mail order business at 117 North Elizabeth street, and James A. Pugh and the Pugh Terminal Warehouse Co. at 365 East Illinois street. The new concern has been incorporated under the laws of Maine for \$8,000,000, and Mr. Lundin was very positive in his statement that all of the stock had been sold for par and that it was nearly all sold. The officers of the new incorporation are Frederick A. Lundin, president, and James A. Pugh, treasurer. The present offices are at 117 North Elizabeth street and the permanent address will be at 365 East Illinois street.

COURT DEBATES AT HOME.

Paris Palace of Justice to Have Phonographic Arrangement.

A novelty in the new buildings of the Palace of Justice, in Paris, France, is a "themisophone,"

which will be offered to all telephone subscribers for a small fee, so that they can hear all the debates in their homes.

Plates have been installed before the bar of the tribunal, in order, according to French journals, that the judges, knowing themselves heard by such a large audience, 'will be more strictly inclined to justice and intelligence.'

NEW STYLES IN SALTER CABINETS.

Latest Styles 60 and 80 Designed for Use with Edison Phonographs of Corresponding Numbers—Harmonize Perfectly with Finishes of Machines—Some of the Structural Details.

(Special to The Talking Machine World.)

CHICAGO, ILL., May 9.—The accompanying photograph shows the No. 60 Salter cabinet, which has been designed by the Salter Manufacturing Co. to be used with the No. 60 Edison disc machine.

Like the No. 80 Salter cabinet, which is advertised on another page of this issue, the No. 60

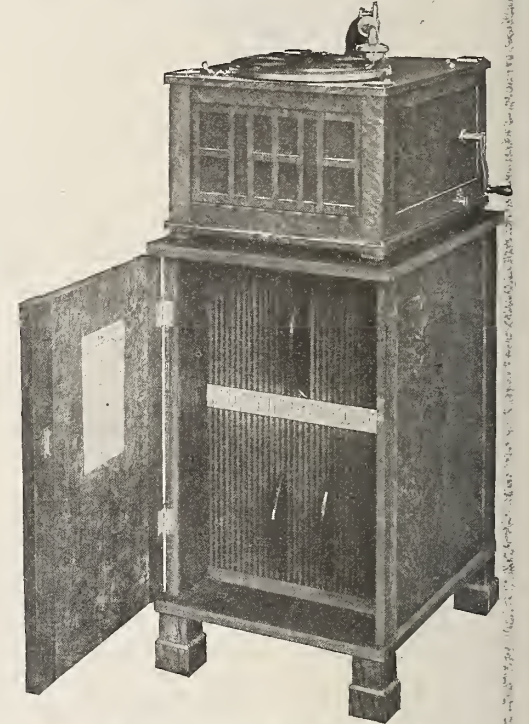

Salter Cabinet Style 60, Open.

harmonizes in every way with the machine it is designed to be used in conjunction with. The cabinet is finished in a fine grade of fumed oak, is mission in design and no doubt will enjoy the same popularity that all of the other cabinets designed by the Salter Manufacturing Co. for use with cabinetless machines have met with.

The No. 60 and the No. 80 cabinets are both fitted with the felt-lined compartments that have distinguished the Salter product. They also both possess a simple and accurate index that enables the owner to find the desired selection instantly.



Increase Your Record Business by Using This New Cover FOR MAIL-ING OUT Victrola Record Supplements

GETTING THE ORDER—The records desired can be marked on the return postal while the recipient is perusing the supplement. No inconvenience—no chance to forget. This means increased business for you.

ATTRACTIVENESS—Illustrations that create attention and tell their story vividly and convincingly at a glance. Color changed monthly to harmonize with the color scheme of the supplement.

DISTINCTIVENESS—A service that is open to but one Victrola dealer in a city.

INDIVIDUALITY—Your name and address printed on the cover. The cover appears to be of your own construction.

RESULT PRODUCING COPY—Appropriate for different occasions.

LINKING YOUR NAME WITH YOUR PRODUCT—Your message is placed before the recipient on every reference to the supplement. It creates an inseparable association between Victrolas and your store. One recalls the other.

PRACTICABILITY—These covers reach you monthly, prior to the arrival of your supplements. You have time to address them before supplements arrive. Merely draw the edge of the supplement over a moist sponge, insert the supplement and fold.

Write us for a sample cover and price list

ABBOTT-YOUNG-ADAIR-CO.
542 S. Dearborn St., Chicago

OUR NEW CUT
CATALOG FOR
SPRING AND
SUMMER
ADVERTISING
JUST
COMPLETED.
SEND FOR IT.

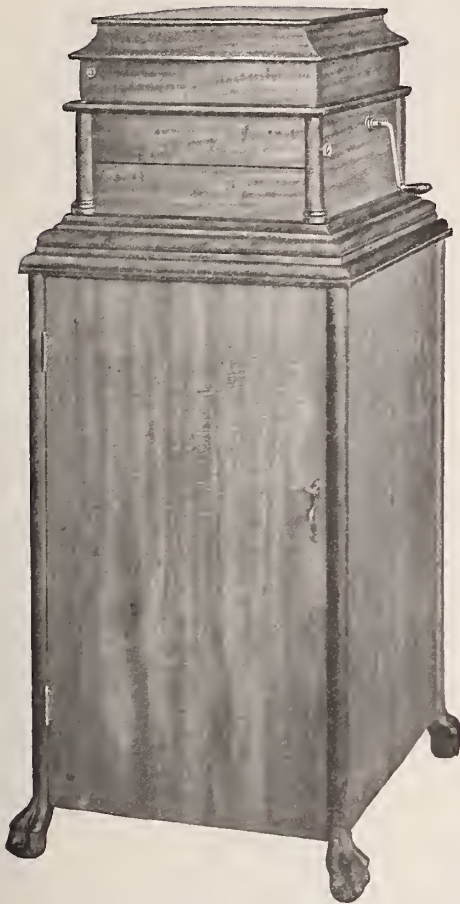

No. 112 Cabinet for Columbia "Favorite."

THE EXCLUSIVE FEATURES

of the

Salter Cabinets

are what make for perfect satisfaction on the customer's part.

NOWHERE ELSE CAN YOU OBTAIN THESE FEATURES. YOU NEED THEM TO-DAY.

Records are perfectly preserved by felt-lined, individual compartments from scratching and warping. Each Record instantly found by our simple indexing system. Dustproof.

THE SALTER LINE has the TALKING POINTS and SELLING FEATURES.

Every Columbia Dealer should write to-day for our Catalog.

SALTER MFG. CO.

337-43 North Oakley Boulevard

CHICAGO

PLANNING FOR SUMMER TRADE IN MILWAUKEE.

Talking Machine Men Expect Big Business from Vacationists—New Records Very Popular—Tisch-Hine Co. in New Quarters—Edison Recital Proves Big Attraction—What the Various Houses Are Doing to Capture Business—Edmund Gram Dansant.

(Special to The Talking Machine World.)

MILWAUKEE, Wis., May 11.—The retail talking machine business in Milwaukee is beginning to ease up somewhat, but dealers are confident that they will meet with a fair trade before the usual summer dullness settles down. One of the most hopeful signs of the situation is the fact that the annual summer resort trade will soon make its appearance. Wisconsin and Michigan are dotted with lakes of all sizes and descriptions, making an ideal summer resort territory. Not only Wisconsin and Michigan people, but people from many of the surrounding States have their summer homes in this district. It is only natural that these people want talking machines in their summer homes and camps, so an excellent field is opened up for the Wisconsin talking machine dealer. The Wisconsin dealer found several seasons ago that summer resorters were good customers for the purchase of smaller styles of machines to be taken to their summer homes. The owner of a large machine does not want to ship this away from his city home, but he is willing to take along a small machine, so that he can play his records and have his usual entertainment.

Dealers and wholesalers report that there is a considerable relief from the shortage of machines and records which has been experienced in Milwaukee during the past few months. Trade is not quite so brisk and dealers have been able to get their stocks up in fairly good shape once more. Jobbers still have some trouble in getting enough of the most popular styles of machines to meet the demands of their dealers, but this situation is not general with every style of machine as was the case a couple of months ago.

Business Outlook Is Excellent.

The general outlook is fairly good and dealers

and jobbers are inclined to be optimistic. Of course, the industrial situation is not quite as brisk as it might be, although it is improved over a month ago. The recently issued report of the Wisconsin Industrial Commission on the free employment bureaus about the state shows that there are few men out of employment. All the big heavy machinery plants in Milwaukee are in operation, although not all are working full time. The crop outlook all over Wisconsin is exceptionally good and reports from adjoining States in the Northwest are just as favorable. Farmers have completed their early spring seeding, and grain is up in most sections of the State. The soil has been in the best of condition all the spring, and, unless something unforeseen happens, a bumper grain crop ought to be harvested. Farmers are now preparing for their corn crop. When crops in this section of the Northwest are satisfactory, it always means that general business is pretty liable to be good.

The New Records Popular.

The new May records put out by the different companies have been selling especially well. Of course, all the dance records, particularly those of the tango type, are decidedly popular, and dealers are put to it to secure enough records in this line to meet the demands of the trade. The booklet just issued by the Victor Talking Machine Co., giving instructions in the new and popular dances, has been in big demand in Milwaukee, and dealers say that it has been a great business getter. Much favorable comment is heard on the excellent manner in which the book has been prepared, showing various poses of Mr. and Mrs. Vernon Castle and moving pictures of the various dance steps.

May Take on Talking Machines.

Frederick D. D. Holmes, manager of the Milwaukee branch store of the F. G. Smith Piano

Co., may take on the agency for a well-known line of talking machines if the necessary quarters can be arranged in the company's store at 90 Wisconsin street.

Move Into New Quarters.

The Tisch-Hine Co., handling the Edison dictating machine in Milwaukee, Wisconsin and upper Michigan, has moved into new and larger quarters at 450 Jackson street. The company has been meeting with such a brisk business in the dictating machines that it was absolutely necessary to secure larger and more quarters.

Crowds Enjoy Edison Recital.

The interesting Edison recital, given recently in the red room of the Hotel Pfister by William Idle, special representative of the Thomas A. Edison, Inc., was a decided success and brought out large numbers of people who were anxious to hear the new Edison disc machines. Mr. Idle, who has been in Milwaukee for several weeks, assisting the Phonograph Co., of Milwaukee, in securing new dealers and otherwise getting the public thoroughly acquainted with the Edison goods, had issued invitations to hundreds of Milwaukeeans. It is said that sales of the Edison disc machines at the handsome new Edison Shop, operated by the Phonograph Co., of Milwaukee, and at all the other Edison agencies, have shown a steady increase since the recital at the Hotel Pfister.

New Edison Agents.

Among the many concerns about Wisconsin, which have taken up the agency for the Edison goods of late, is the Heppes Cash Store at Hartford, Wis. The firm has arranged attractive new parlors on the second floor of its store and has been holding a series of public recitals to acquaint the public with the new Edison disc machines. The Phonograph Co., of Milwaukee, now has several hundred Edison dealers in Wisconsin alone.

Mrs. Frances E. Clark a Visitor.

Mrs. Frances E. Clark, formerly supervisor of music in the Milwaukee public schools and now head of the educational department of the Victor Talking Machine Co., is in Milwaukee at the

(Continued on page 42.)

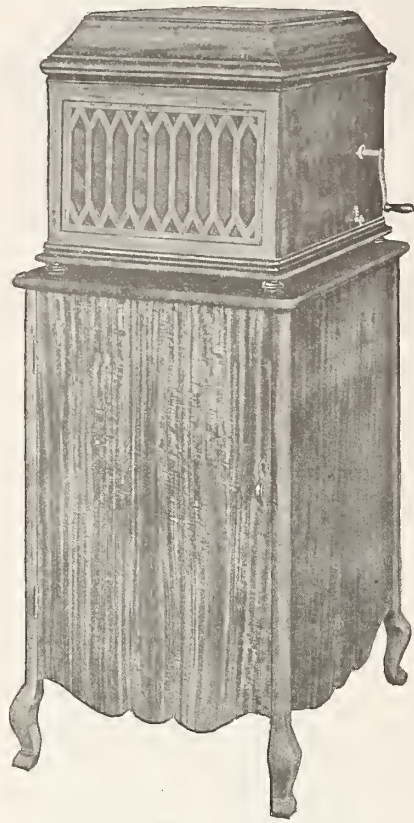

For No. 80 Edison Disc Machines.

The New Salter EDISON Cabinet

With an Individual Felt-Lined
Compartment for Each Record

Front, Back and Sides of 5-ply stock. Outer surfaced with selected figured Mahogany or quarter-sawed White Oak. The heavy round columns are one piece. Top solid Mahogany or Oak, finished to match machines. Trimmings all heavily nickel-plated.

Size 33 $\frac{1}{4}$ inches high by 20 $\frac{1}{4}$ x 25 inches

Holds 72 Records

SALTER MFG. CO.

337-43 North Oakley Boulevard

CHICAGO

PLANNING FOR SUMMER TRADE IN MILWAUKEE

(Continued from page 41.)

present writing as the guest of Miss Margaret L. Canty, supervisor of primary work in the local public schools. Mrs. Clark stopped over in Milwaukee on her return from the music supervisors' national conference in Minneapolis. Mrs. Clark, while connected with the Milwaukee schools, was the first to introduce the talking machine as an agency in the teaching of music, and her phenomenal success here attracted the attention of educators all over the country.

Closed Many Victrola Sales.

Paul A. Seeger, manager of the Victor department at the Edmund Gram Piano House, has been especially fortunate of late in securing a large number of high-grade Victrola sales. The talking machine business at the Gram house is double that experienced a year ago.

Gimbel Bros. Concentration.

The recent action of Gimbel Bros., in combining their piano and Victor departments in connection with the Victor quarters on the second floor, seems to have been a most satisfactory arrangement, as L. C. Parker, manager of both departments, reports that business in both lines has shown steady increase of late. The Victor business at the Gimbel store during April attained a new high mark.

To Enlarge Quarters.

C. W. Abbott, manager of the Victor department at the Boston store, has completed plans for enlarging the present Victor quarters at the store. Handsome new booths will be installed and double the space will be available. It is expected that the work will be done before next fall. A brisk business is reported by Mr. Abbott.

Record Shortage Still Noticeable.

Harry T. Fitzpatrick, manager of the Wisconsin Talking Machine Co., jobber for the Victor line, says that several new Victor dealers have been secured in Milwaukee and about the State during the past month. Mr. Fitzpatrick reports that his company is now able to meet the demands

of dealers for Victor machines, but that a record shortage is experienced at times. Miss Gertrude F. Gannon, head of the Wisconsin Talking Machine Co., has returned from a visit to her former home at Dixon, Ill.

Battin Managing Schuster Department.

A. H. Battin has assumed the management of the Victor department of the Edward Schuster & Co.'s department store at Twelfth and Vliet streets. Plans are under way for arranging new and larger quarters for the Victor department at the Schuster store on Third and Garfield streets. Miss Elizabeth Hughes is in direct charge of this department. Miss Hughes has been meeting with a fine business of late.

Window Displays Interest.

J. H. Becker, Jr., manager of the Victor department of the Hoeffler Manufacturing Co., 306 West Water street, has been arranging some unusually interesting window displays since he assumed charge of his former position at the Hoeffler store. Mr. Becker has been engaged in the talking machine business in Milwaukee for the past ten years and the many friends whom he has made have followed him to the Hoeffler store, so the business of the talking machine department of that store has shown a decided increase of late.

Prominent Dancers Interest.

Mr. and Mrs. Vernon Castle, the well-known society dancers of New York, were scheduled to appear at the Pabst Theater in Milwaukee on May 11, and every Victor house in the city has made the most of the advertising opportunities which the event has afforded. The Castles' testimonial regarding the Victor line has been featured in the local papers, while dealers all over the city have begun sending to their customers the little booklet, issued by the Victor Talking Machine Co., called "Three Modern Dances," illustrated by moving pictures, with complete instructions and full size photographs of Mr. and

Mrs. Castle. The sales of dance records have, naturally, increased at a remarkable rate as a result of the visit of the Castles.

Kunde Featuring Columbia Line.

A. G. Kunde, Columbia jobber and retailer, has moved from his former location at 516 Grand avenue to temporary quarters at 915 Grand avenue, where a very attractive and high-class store has been opened to the public. Three new booths have been erected and new fixtures have been installed throughout. The Miller Brewing Co. is preparing to erect a large store and office building on the site of the store formerly occupied by Mr. Kunde and, when it is completed, probably about October 1, Mr. Kunde will open a large and handsome store in the new structure. Mr. Kunde says that the new store will be one of the finest in Milwaukee, and one that will do justice to the Columbia line.

Report Big Business.

Officials of the Gensch-Smith Co., featuring the Victor line at 730 Grand avenue, say that if business in both the talking machine and piano line continues to improve as it did in April, it will be necessary to seek larger quarters. The sales force covering Milwaukee has been increased several times of late.

Fashionable Dansant Attracts.

Something new for Milwaukee piano houses was inaugurated by the Edmund Gram Piano House on May 8, when it featured a "dansant" in its Steinway parlors. Miss Frances Pritchard and Chester Hemmer, both of New York, demonstrated the new dances and showed what perfect music is furnished by the Victrola and the Pianola. Two programs were rendered, one at 4 o'clock in the afternoon and one at 8.30 in the evening. Tea was served in the afternoon and refreshments in the evening. Large crowds of people attended, and the affair proved to be a great advertising scheme for the Victrola and the dancing records. Paul A. Seeger, manager of the Victrola department at the Gram store, operated the Victrola XVI., which was used.



No One Can Tell THAT THE MACHINE AND CABINET Are Not Built As One

This pleases customers and helps sales. Other features of all **SALTER** Cabinets are powerful influences for sales. The separate, felt-lined compartments assure a customer. He can see that Records will not scratch or warp, but remain as good as new.

THE **SALTER** LINE is a great help to any dealer in making A PROFITABLE BUSINESS

Write for our complete Catalog.

SALTER MFG. CO.

No. 19 Cabinet for No. IX Victor Machine.

337-43 North Oakley Boulevard

CHICAGO

ENTERS TERPSICHOREAN FIELD.

R. M. Hunting Resigns from New York Talking Machine Co. to Exploit Modern Dances.

R. M. (Bob) Hunting, Jr., one of the popular members of the road sales staff of the New York Talking Machine Co., 81 Chambers street, New York, Victor distributor, resigned from this position last week in order to devote all his time to the exploitation of the modern dances. Mr. Hunting ranks with the most successful professional dancers now before the public, being exceptionally gifted in this direction.

At the present time Mr. Hunting is confining his dancing primarily to the presentation of the modern dances in conjunction with Victor products. Mr. Hunting is calling on many of the leading Victor dealers and arranging to demonstrate at their warerooms the adaptability of Victor dance records to the artistic interpretation of the modern dances. His many years of experience in the Victor selling field, coupled with his remarkable dancing talent, have enabled Mr. Hunting to offer real co-operative service that has resulted in the

dealers' closing numerous sales of machines and dance records.

MORTIMER D. EASTON MARRIED.

Mortimer D. Easton, son of President Easton, of the Columbia Graphophone Co. and advertising manager of the Dictaphone, was married last Saturday to Miss Marie Rankin, of Goshen, N. Y. The wedding, which was held at the home of the bride, was a very simple one, only the near relatives of the bride and groom attending.

Mr. and Mrs. Easton sailed Tuesday for a six weeks' trip abroad and according to their present plans will visit England, France, Switzerland and Italy, returning to America by way of the Riviera. While abroad Mr. Easton will pay a visit to the London office of the Columbia Co.

NEW J. N. ADAM VICTOR MANAGER.

Westley R. Clifford, formerly connected with the Victrola department of the Forbes & Wallace store at Springfield, Mass., has been appointed manager of the Victrola department of J. N. Adam & Co.,

Buffalo, N. Y., one of the stores controlled by the Musical Instrument Sales Co., New York. E. P. Cornell, Victrola purchasing agent of the M. I. S. Co., visited Buffalo this week to attend Mr. Clifford's installation as manager.

CHANGE MADE IN WAREROOMS.

Talking Machine Department of Pease Piano Co., Brooklyn, Moved to First Floor.

The talking machine department of the Pease Piano Co.'s branch at 34 Flatbush avenue, Brooklyn, handling both Victor and Columbia products, has been moved from the basement to the first floor of the store, with the convenience of customers as the main object. Three attractive sound-proof rooms have been fitted up in the rear of the main warerooms for the display of talking machines and the demonstration of records.

DANCING HELPS BUSINESS.

Up-State Merchant Says Demand for Music Records Is Active.

"Business up the State is dull," said a merchant from a northern town yesterday. "There is only one line of my trade that is active, and that is growing so fast I can hardly keep up with it. It is due to the craze for dancing.

"I put in a talking machine department some time ago, and business in it has been pretty regular until people began to dance. Lately I have had to increase my force in that department, and it is doing a big trade. The biggest demand is for dancing records. I cannot get them in sufficient quantities to supply the demand."—New York Times.

TRUTH WELL STATED.

"When a manufacturer puts his business name and the retail price on his merchandise, he has practically signed a contract with the public to deliver goods worth that price. His success depends upon public approval of the quality at the price."—American Fair Trade League.

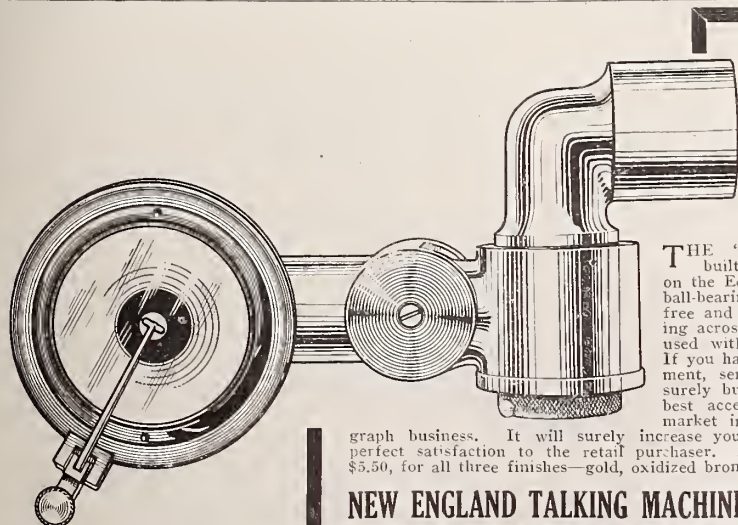

Edison DISC Phonograph Dealers

THE "Perfection" Attachment is built to play lateral cut records on the Edison Disc Phonograph. The ball-bearing hanger joint gives it a free and flexible motion when traveling across the record; also it can be used with or without the feed rake. If you haven't seen or had this attachment, send us an order. You will surely buy more, as it is one of the best accessories ever placed on the market in the history of the phonograph business. It will surely increase your machine sales, as it gives perfect satisfaction to the retail purchaser. Reproducer and Attachment, \$5.50, for all three finishes—gold, oxidized bronze and nickel.

NEW ENGLAND TALKING MACHINE CO. 132 Boylston Street BOSTON, MASS.



Pavlowa, the incomparable, rehearses to the music of Columbia instruments and Columbia dance records. Do you grasp the significance of such an endorsement as an advertising possibility in your locality?



(Write for "Music Money," a book "full of meat" for those dealers interested in quick and frequent turnover of capital.)

**Columbia Graphophone Company
Woolworth Building, New York**

TALKING MACHINE TRADE BOOMING IN ST. LOUIS.

Jobbers Report Excellent Volume of Orders from Out-of-Town Dealers—Aeolian Co., Department Getting Settled in New Quarters—Columbia Co. Store to Be Remodeled—Many New Additions to List of Edison Disc Dealers—Recent Visitors to the City.

(Special to The Talking Machine World.)

St. Louis, Mo., May 9.—The talking machine business in this vicinity is keeping up the merry clip that it has set for this year. There may be a slight lull in the retail business, but what has occurred there is more than offset by the pace set by the jobbing business. The jobbers, without exception are declaring that out-of-town trade has been excellent and gives every indication of continuing so. The orders, too, are very satisfactory in that they are for fairly high-priced machines. The day of shipping any old thing to the country evidently has passed. The same is true of records. The jobbing business on records has been along the same numbers as that demanded by the town trade. The dance continues to be the thing.

Harry Levy, manager of the Aeolian Co. talking machine department, reports excellent jobbing business while he is getting settled in his new quar-

ters at the Furniture Exchange Building at Fourteenth and Locust streets. Already, he says, it has been demonstrated that business can be handled with more facility in the new quarters, where his force has sufficient space to handle several orders at once, than in the old cramped quarters. He also is learning how much time it takes to build the necessary furniture for a healthy jobbing talking machine business. At the old plant they built here and there as the furniture was required, and when it came to moving this plant and building what was needed in addition, he finds that it is more of a job than he anticipated and, instead of being ready for business in the best form by the 1st of May, he is counting on getting to regular pace in dispatching orders by May 15.

Stocks are in better shape, Mr. Levy reports, and despite handicaps, he has been handling the business in excellent form.

"The record business has been the retail feature," Mr. Levy said. "While the grand opera season made a demand for records of that class, it cannot be denied that the dance is the thing and that most people would rather remain at home or go to a neighbor's and dance to a talking machine than go to hear any of the real opera stars. The free book showing how to execute three of the new dances is going to be an excellent business promoter."

At the Columbia Co.'s warerooms General Manager Duffy and Retail Manager Duffy each have one principal object in their present work. Mr. Reid is looking forward to the remodeling of the store, and he hopes to see this work begin any day now. The start has been delayed because of the weather, which has been decidedly uncertain, and as the contemplated changes include the practical taking off of the building, none there is anxious that it shall begin until they are at least assured of tarpaulin weather until the changes can be made. The company will stay in the quarters while the changes are being made and expects some inconvenience while the work is under way, but it expects to more than make up for lost time when the new store is attractive to visitors.

Mr. Duffy's principal object of attack is that purely summer form of trade that comes from summer clubs, outing organizations and the like, and he has a nice line of this business lined up, some of them for rather high-priced machines, and he has delivered a number of the smaller machines for the outing clubs that do not have quarters sufficient to justify the investment in a high-class machine. The Columbia sales force believes that the dance fad of this year will bring increased trade along this line.

The Columbia made considerable effort to realize on the grand opera records after the brief season of that music, and is convinced that it captured its share of the trade that resulted.

Mark Silverstone, of the Edison Shop, says that he has at last found an insurmountable difficulty to

selling an Edison disc machine. He did not think there was such a thing until a few days ago, when he voluntarily took back a machine that had been placed in the home and the sale signed, sealed and delivered in the most proper form. The obstacle to the deal came from a most unexpected quarter. It was a note from the agent of the apartment house in which the purchaser lived to the owner, notifying him that phonographs were not permitted in the building and that he had waived the privilege of such music when he had signed the lease for the apartments. The letter continued:

"The other tenants are complaining about your machine, not so much because of objections to a phonograph, but rather in the spirit that if you are permitted to have a phonograph they should be permitted to have one too."

The purchaser of the Edison disc was probably the most disappointed person concerned in the deal. He had had the machine in his apartment long enough to get very much attached to it, and it was with regret that he returned it.

Miss M. L. Sutter, secretary of the Silverstone Music Co., has given notice of her intended retirement in the near future, as she will be married to W. W. Ohlweiler the latter part of June.

M. L. Reynolds, the Silverstone traveler, is in Arkansas and southern Missouri this month, and is reporting some excellent business and new disc dealers.

The Silverstone Music Co. list of Edison disc jobbers has reached the century mark, twelve of whom are in the city. The 100th firm put on the list was the Hollenberg Music Co., of Little Rock, Ark. Some other new dealers are: A. B. Carne, Pierce City, Mo.; Benedict-Boyce Music Co., Galesburg, Ill.; McQueen Bros., Carrollton, Mo.; C. W. Hess, Butler, Mo.; Bush & Carne, Dyersburg, Tenn.; T. J. Evans, Pittsburg, Kan.; W. H. Moreland, Jr., Metropolis, Ill.; N. T. Holbrook, Carthage, Mo.; H. L. Hoover, Springfield, Mo.; J. W. Guisinger, Fayetteville, Ark.

E. E. Paddon has been added to the office force of the Silverstone Music Co.

Some recent visitors from near-by territory were: J. J. Dowdy, of Dexter, Mo.; F. J. Haley, Jr., Louisiana, Mo.; Miss Benedict, of the Benedict-Boyce Music Co., Galesburg, Ill., and John Prader, of Paris, Mo.

A COMPREHENSIVE TRADE LINE.

Attractive Specialties Carried by the S. B. Davega Co. Which Will Interest Dealers.

The S. B. Davega Co., 831 Broadway, New York, is a business enterprise conducted in an up-to-date manner in every respect. Aside from being large jobbers of talking machines, this company jobs a line of specialties which have been found by many to go perfectly with the talking machine line. Included in this are Ingersoll watches, sporting goods of various kinds, Gillette razors, Thermos bottles, roller skates, etc. During the dull season the talking machine dealers have found that these accessories blend closely with the talking machine business, making it possible to create a patronage for the various lines which help to meet overhead expenses.

Simplest and Most Accurate.

Net weight only 1½ oz.

Standard Automatic Stop

Nickel . . . \$2.00

Gold . . . 3.00

*Send 25 cents stamps
for free sample*

Order through your jobber.

Liberal Discounts.

**Standard Gramophone
Appliance Co.**

173 Lafayette St., New York

FINE QUARTERS IN PITTSBURGH.

Work of Remodeling Store of Columbia Co., Burned Out Some Time Ago, Progressing Rapidly—Kaufmann Bros. Elaborate Department Now Completed—Talker Department for Sterling Piano Co.—Other News.

(Special to The Talking Machine World.)

PITTSBURGH, PA., May 8.—Work on the local Columbia branch, which burned out the first of the year, is progressing rapidly and Manager S. H. Nichols says it will be ready for occupancy by about May 15. When completed, the store will be one of the finest and most up to date in this section of the country. The demonstrating rooms, which have been increased to nine, are finished in mahogany and will be made practically sound-proof. The entire inner part of the building has been rebuilt and the mezzanine floor, which will be occupied by the offices and bookkeeping department, has been greatly enlarged. The company has had temporary offices in the Bessemer building and also opened a temporary store in the Fulton building, as soon as a new stock could be se-

cured after the fire. In spite of the great handicap under which business has been carried on, Manager Nichols reports that the trade for April was much larger than that of the same month last year.

The Kaufmann Bro.'s Victrola department, which started out last January under many disadvantages of lack of equipment, has been brought, within the past few weeks, to a point that closely approaches perfection, through the untiring efforts of the manager, H. N. Rudderow. The department is on the eleventh floor of the splendid new Kaufmann building. It contains eight demonstrating rooms, measuring ten by ten feet, and made of double French plate glass. These booths were planned by Mr. Rudderow in conjunction with the architect, and alone cost \$17,000 to erect. Another feature is the record shelves, also designed by Mr. Rudderow, to accommodate the two complete stocks of records which are kept on hand. Taken as a whole, the department is of the most complete and carefully appointed to be found anywhere. Just off of the Victrola and piano departments there is under construction a

large concert hall, which promises to be unique in every way. In size and from the viewpoint of architecture and decoration it will rival many of the local theaters. The lower floor will seat close to 1,000, and the balcony, which surrounds three sides of the auditorium, will accommodate four or five hundred more. Victrola concerts will be held here at regular intervals, Saturday being set aside for entertaining juvenile audiences. Manager Rudderow, who was formerly with E. F. Droop & Sons Co., Washington, D. C., feels justly proud of what has been accomplished thus far in the Kaufmann Bros. new department, and he declares that the outlook is exceedingly bright.

An indication of the tremendous demand for Victor talking machines in this territory is apparent on a visit to the busy quarters of the Standard Talking Machine Co., of which J. C. Roush is manager. The output of Victors is breaking all records, and the indications now point to a year that will mark a new precedent.

The Sterling Piano Co. is contemplating the installation of a talking machine line, but plans have not yet fully matured, nor has any particular line been decided upon.

The S. Hamilton Co.'s talking machine department reports a splendid business for its first month at 815-817 Liberty avenue. The S. Hamilton Co. has been featuring the "V. E. C. Triplets."

The Boggs & Buhl talking machine department, recently removed from the second floor to its splendid up-to-date quarters on the fourth floor with the new piano department, has had a very encouraging amount of business. A large addition has been made to the stock of records, and preparations are being made to handle a rapidly growing trade.

The McCreery & Co. Victrola department, under the new management of Chas. S. Hotaling, reports an exceptionally good business for the past month, and a promising outlook for the future. Although the department is not as large as some in the city, there are few anywhere that can compare with it in point of furnishing and equipment. There are five elegantly furnished demonstrating rooms and one large parlor for displaying instruments. All are lit by the indirect system, which brings out the beauty of the instruments, furniture and draperies to the fullest extent. The highest class of trade is catered to exclusively, and no expense has been spared in making this one of the finest sections in the McCreery store. The department was installed a year and a half ago by the Musical Instrument Sales Co., of New York, making this another link in their long chain of Victrola and piano departments in many large cities all over the country. Mr. Hotaling, who has been with the company ever since its coming into existence, was recently sent to put the Pittsburgh department on a higher basis. With the hearty co-operation of McCreery & Co. his success here has exceeded even the highest expectations.

A. N. THOMAS TO GO TO MANILA.

A. N. Thomas, connected with the Columbia Graphophone Co.'s retail department for a number of years, will sail next week for Manila to become manager of the talking machine department of I. Beck, Inc., a large and progressive store in that enterprising city.

PATHE FRERES CO.'S NEW QUARTERS.

The Pathe Freres Phonograph Co. has leased the entire second floor of the building just erected at 29-33 West Thirty-eighth street, New York. The company will announce its plans for the usage of this 5,000 square feet of floor space in the very near future.

LYNCH APPOINTED MANAGER.

W. Lynch, formerly connected with Landay Bros. and Sol Bloom, well-known local Victor representatives, was this week appointed manager of the Victrola department of the O'Neill-Adams Co., New York. John L. Post, manager of this store's piano department, had also been acting as manager of the Victrola department prior to Mr. Lynch's appointment.

41 Union Sq., New York**TO OUR CUSTOMERS:**

We are informed that a certain company is advising the trade that it has brought suit against us on certain of its patents.

We wish to notify our customers that this suit will be vigorously defended by us, and we have the utmost confidence in the outcome of the litigation. We are advised by our patent counsel,

Mr. Waldo G. Morse and
Mr. John L. Lotsch, of 10 Wall Street,
New York, N. Y.,

that we do not infringe any valid and existing patents owned by *any* company, and that we stand ready to defend our customers against all litigation. If you are served with any papers, communicate with us immediately.

TRITON PHONOGRAPH CO., Inc.

By JOEL A. KRAUS, As President.

TO THE TRADE:

If you are sued it will be to your interest to communicate with our patent counsel or us immediately.

ACTIVITY IN INDIANAPOLIS.

The Leading Talking Machine Establishments Handling the Various Lines Are Doing a Very Satisfactory Business—Stewart Talking Machine Co. Removes Its Wholesale Rooms—News of Month Worth Recording.

(Special to The Talking Machine World.)

INDIANAPOLIS, IND., May 4.—Although there has been a great deal of unrest in connection with the county and township primaries which will be held Tuesday, May 5, the talking machine business has not been affected. All dealers report good business conditions.

The Columbia Graphophone Co.'s store at 27 North Pennsylvania street, reports a large sale of the records made by Margaret Woodrow Wilson. An attractive window display was put on by the Columbia Co., showing a photograph of Miss Wilson and a small American Flag which was kept flapping by a hidden electric fan.

The Stewart Talking Machine Co. is enjoying a good business, and W. S. Barringer, manager, and his help is somewhat more cheerful as the result of the Victor factory sending some goods out this way. The Stewart company has the faculty of getting the orders. Its only difficulty has been to get the goods to fill the orders.

The Stewart Talking Machine Co. has moved its wholesale warerooms from North Alabama and Court streets to the Wulsin building, a new industrial block, in East Ohio street, just east of North Delaware street. The new wholesale department of the Stewart Talking Machine Co. is very attractive and much more roomy. The additional business which is being handled by the company made necessary the move into larger quarters.

The Kipp-Link Co., distributor of the Edison machine, is enjoying a decided increase in the sale of the new Edison disc machines. Announcement of several downtown depots where the Edison disc machine may be obtained is expected from the Kipp-Link Co. in a few days. It is known that contracts for several places have been made between downtown stores and the Kipp-Link Co.

OPERATIC RECITALS IN DALLAS.

The Dallas Talking Machine Co., of Dallas, Tex., has been featuring extensively during the past few weeks a series of operatic lectures by Prof. Hans Kreissig, a well-known musical authority. The operas presented by Prof. Kreissig included "Tosca," "Rigoletto," "La Boheme" and "Aida." Victor records were used to illustrate each opera, and the series of lectures attracted crowded houses.

VICTROLA FOR IMPERSONATOR.

Miss Ruth Graham Purchases Instrument from Neal, Clark & Neal Co. After Many Tests.

(Special to The Talking Machine World.)

BUFFALO, N. Y., April 30.—Miss Ruth Graham, an impersonator, who has made the Littlest House at Williamsville, N. Y., her permanent home, has purchased a Victrola from the Neal, Clark & Neal Co., Main street, this city. Miss Graham is a New York artist, playing chiefly for New York's four hundred. When Miss Graham bought the Victrola she told W. J. Bruehl, manager of Neal, Clark & Neal's, that she decided to take the Victrola because of its fine tone and the remarkable range of music at her disposal.

INTRODUCES THE TRITON MOTOR.

Quite a large demand is being created for motors for talking machines, and, it is said, that this field of endeavor is proving very prolific to the companies having the proper line of merchandise. The Triton Phonograph Co., 41 Union Square, New York, in addition to selling the Triton Phonograph, which retails for \$10, is offering a line of talking machine accessories among which is the Triton motor.

This is illustrated elsewhere in this issue, the main feature of the Triton motor, being its simplicity. "There is not a surplus piece of metal about the Triton motor," added Mr. Kraus, manager, "and every part has its definite function to perform. This makes the cost exceedingly low. All parts of it are made at our factory at Berlin, Germany, and we guarantee it to be solid and durable. It is noiseless and may be wound while the instrument is playing."

BREAKING ALL RECORDS.

"Up to the present time we have closed the best year in our history," said G. T. Williams, manager of the New York Talking Machine Co., 81 Chambers street, New York, the prominent Victor distributor. "Month for month we have shown a splendid gain over the preceding months of 1913, and our business up to the 20th of April exceeded that of the entire month of April of last year, which was, by the way, the best April in our history."

When you look about in a moving picture show in the afternoon and wonder how in the world so many men fool away time in that fashion, you can be sure that's just the thought that occurs to the other men!

FIVE NEW ARTISTS IN LINE.

Mme. Kitty Berger, of Harp-Zither Fame, and Elias Breeskin, Violinist, and Three Vocalists Make Records for Thos. A. Edison, Inc.

Five artists are being featured by Thos. A. Edison, Inc., in its July list of records, all of whom make contributions of merit; two, in par-



Eugene Emmett.



Homer Rodeheaver.

ticular, have won a national reputation which will insure their records being received with consideration and approval.

Elias Breeskin, who got his early instruction in the Imperial Conservatory of Ekaterinoslav, Russia,



Irving Kaufman.



Elias Breeskin.

and who was a student of Franz Kneisel after his arrival in this country, is represented by two numbers for the violin—Schumann's "Traumerei" and "Romance." This young Russian produces a full, rich, authoritative tone of noble quality.

Mme. Kitty Berger, the celebrated harp-zither player, who is unique in this field and widely known and esteemed in musical circles, introduces herself and this beautiful instrument in that lovely Irish melody of Moore: "Believe Me If All Those Endearing Young Charms." The harp-zither makes a remarkable record, and as played by Mme. Berger is an artistic treat.



Kitty Berger.

Eugene Emmett sings with rare charm and native ability "Norah McNamara," a typical Irish song, in which he displays a tenor voice which is a keen delight. Irving Kaufman, tenor, sings "I Love the Ladies" with vim and enthusiasm, while Mr. Rodeheaver, who is musical director of the evangelist meetings of "Billy" Sunday, makes admirable records of six revival hymns, which he sings in a robust baritone voice with tremendous force and conviction.

RECEIVER FOR ALBUM MAKER.

Charles L. Brookheim has been appointed receiver in bankruptcy for Edwin F. Skinner, manufacturer of albums for holding talking machine records at 27-29 Walker street, New York, under the title of the Shafford Album Co. A meeting of the creditors will be held on May 1 at the office of Peter B. Olney, referee in bankruptcy, at 68 William street.

Special

Send for a package of our Improved Half-Tone and Loud Tone Needles in New Style Envelopes.

If you want to advertise yourself, we will put your own name or trade-mark on the envelopes, or will pack in Puritone envelopes.

Quality Guaranteed

The Best Needles mean profit and satisfaction.

If you want to sell 1,000 Needles at a time instead of 100, use the "Dean-packed" Needles. Five boxes of 200 each, Extra Loud, Loud, Opera, Medium and Soft packed in a carton. The best package and fastest seller on the market. Write for samples.

JOHN M. DEAN, CORP.

Talking Machine Needle Manufacturers

PUTNAM, CONN.

TRADE PULLING POWERS OF CLOSE OBSERVATION.

Ability to Observe Closely Is of Inestimable Value to the Talking Machine Dealer—An Art That Should Be Developed—Represents the Key That Has Unlocked the Doors of Success to an Army of Business Men—Practical Talk for Practical People.

When that troublesome customer, Business Depression, pays you a visit, as he has a way of doing with every member of the "talker" fraternity at some time or other, and you find yourself groping about in the murk of despondency, bring your forces of observation into action. Find out what your more fortunate competitor is doing and follow his lead, adding thereto, sundry elaborate variations of your own.

All that any business man endowed with a normal brain needs nowadays in order that he may achieve at least a modest portion of success is an idea in embryo to work upon. Therefore, when the storm clouds heralding the approach of the failure tempest loom blackest, go out and find that idea. A simple solution of the problem, is it not? Your journeying need not be extensive. You may find what you want in the same block. It may be gazing out at you from the window next door or from the one across the way. At all events, you will find it somewhere and in short order if your power to observe has been developed to a sufficient sensitiveness.

A very good way to get at the wished-for idea is to make a comparison between the other fellow's store and your own. This proceeding being carried out with care and deliberation, arrive at a conclusion from the data at hand, whether the said comparison is in the other fellow's favor; and if so, in what particular? That point being made clear, all you have to do is to borrow a little of his superiority. Then the storm clouds dissolve, and the sunshine of success invades your establishment once again.

Were I a talking machine dealer, Mr. "Talker" Man, my method of getting at a trade-bringing idea in the shortest possible space of time would be through the medium of a trade journal. Do you ever peruse the pages of The World for any other purpose than to run through the local news and the advertisements? Let me ask you a personal question: Do you see this periodical every month? In the mountains of Kentucky there are folks who cannot call the President of the United States by name, and who have never heard the strains of a phonograph—two deplorable proofs of their primitiveness. It seems to me, Mr. Dealer, that the "talker" man who does not subscribe to The World resides in the vicinity of the Kentucky mountains, so far as trade doings are concerned.

The function of a trade journal is to provide a rich mine of information relating to the particular field of which it is the representative, and to neglect taking advantage of the opportunities it presents to acquire valuable recipes for big business is a great mistake and shows a poorly developed sense of observation.

Believe me, I am not writing this to curry favor with my editors. They may think this story sounds too much like an advertisement, and return the manuscript, for all I know. However, my deep-seated respect for what The World means to every talking machine dealer who subscribes to it, bids me take a chance. Therefore I boldly state that some day I hope; yes, and expect, to see it in the hands of every "talker" man on the globe. It is unique in its line. Why should it not be thus widely circulated.

Another thing that I desire to get off my chest is the fact that The World is mighty good reading for the owners as well as the sellers of talking machines. Its instructive articles relative to the latest developments in graph and phone manufacture, the advance record lists, the able editorials, the latest patents, etc., are all of vital interest to everyone who owns a "talker."

In glancing through the April number I find no less than eleven stories which I guarantee to provide absorbing entertainment to the public at large. I back up my assertions as follows:

- Page 4, Makes Records of Birds' Voices.
- Page 7, Process for Enlarging and Reducing Disc Records.

Page 36, F. J. Bowers, Pathé Freres, Tells of World Trip.

Page 38, Reminiscences of Early Talking Machine Days.

Page 39, Miss Wilson's Columbia Records.

Page 43, Supervising Dance Records.

Page 50, The Rimington Color Organ.

Page 51, "Stage Fright" Before the Talking Machines.

Page 51, Will Reward Inventors.

Page 52, Latest Patents Relating to Talking Machines and Records.

Page 54, Record Bulletins for May, 1914.

Read the above list carefully, and you cannot but agree with me.

I don't suppose you ever thought to show The World to your customers, or to explain to them why they should subscribe? It will be to your interests to do this, because after a careful perusal of its pages they will not only cease to be tyros at the "talker" game but will come to you equipped to talk trade in your own tongue. This will save your vocal organs from the exertion of answering what must often seem foolish questions and place you on a mutually agreeable footing. Try it and see.

There is no reason whatever why a business periodical as newsy and instructive as The World should confine its circulation strictly to trade boundaries, and the sooner you realize this and pass the good word along to your patrons, the better it will be for everybody concerned.

Returning to the subject, "The Trade Pulling Power of Close Observation," the Philadelphia Evening Telegraph has this to say:

"The power of observation is indeed a wonderful gift, a gift no worker on the success road can afford to slight or overlook. It is the factor that causes men to rise from obscurity to fame.

"Strange as it may seem, at times a perfect stranger to the inner workings of a business can suggest ideas and innovations which the person who is on the inside fails to observe, simply because he lacks concentrated power of observation. As an example, the owner of a small store in the outlying district of the city was one day observed by a salesman looking intently at his windows, at the same time scanning the store front of his

neighbor, and also competitor, in the next block.

"He noted that trade seemed to pass by his store and make for the store in the next block, but for what reason he could not fathom. Both stores sold about the same line of goods at almost identical prices; both rendered about the same service; the location of both was on a par. The salesman also noticed the store front of the concern that seemed to be getting the business was brightly painted; presto! he had the solution.

"Turning to the merchant he said: 'The reason your trade is falling off is that your store presents an antiquated appearance, the front is badly in need of a coat of paint; the passer-by thinks the goods on your shelves are on a par with the exterior of your store. Note the bright, spic and span



How Keen Observation Counts.

appearance of your rival; the paint and woodwork fairly glisten in the sunlight.'

"The merchant for the moment was insulted.

"Said he to the observant salesman: 'What do you know about storekeeping? You never kept a store.'

"No," replied the alert salesman, "I never did; on the other hand, I never laid an egg, but I know a good omelet."

By way of finale, Mr. Dealer, allow me to suggest that you consider with sufficient gravity two questions:

First—The great stimulus that can be given your business through the faculty of keen observance.

Second—that the relations between your patrons and yourself can be mutually enhanced by introducing to them The Talking Machine World.

HOWARD TAYLOR MIDDLETON.

"Don'ts and cant's" are among the greatest stumbling block on the road to success.

UNION SOUND BOX



PRICE: Gold plated, \$5.00. Nickel, or oxidized, \$4.00.

4 EASY SELLERS—

AT the left is the new UNION Sound Box just out, taking Fibre or any make of needle. It is the latest improvement in sound reproduction, and fits all Disc Machines.

UNION TALKING MACHINE SPECIALTIES

The upper right-hand illustration shows UNION No. 1, for playing Columbia and Victor records on Edison Machines. UNION No. 1 contains the UNION Modifier feature. The lower right-hand illustration shows the UNION Needle, a quick-selling device, giving Edison, Victor and Columbia owners absolute control over the volume of sound. The UNION NEEDLE BOX fills another long-felt want.

Write to-day for descriptive folders and prices on these four easy-selling specialties.

List prices shown here, usual discount to dealers

All persons selling goods infringing our patents are liable to suit for such infringement.

THE UNION SPECIALTY AND PLATING CO.

409 Prospect Ave., N. W. Cleveland, Ohio

UNION No. 1
Patent No. 776-672, others pending.



PRICE: Gold plated \$2.50
Nickel or oxidized .. 2.50

UNION NEEDLE BOX for Edison Machine.



PRICE: Finished in Mahogany, Circassian Walnut or Fumed Oak, any finish, 50c.

UNION MODIFIER



Pat. Pend.

WRITE FOR NEW FOLDERS

PRICE: Gold plated, \$1.00
Nickel or oxidized... 1.00

OPEN NEW VICTOR DEPARTMENT.

Elaborate Preparations Being Made for Handling the Line in the Store of Lindsay & Morgan Co., Savannah.

(Special to The Talking Machine World.)

SAVANNAH, GA., April 27.—A Victor talking machine department has been added to the business of the Lindsay & Morgan Co. Workmen are now engaged in the construction of booths and the converting of space on the main floor for the new department.

The matter of the new department has been under the consideration of the officers of the company for some time and it was decided that the time was ripe for the company to enter the field. The decision carried with it provision for an extensive line of Victor machines and records.

The new department will be under the management of Benjamin F. Rensing, who has been connected with the company for a number of years as cashier.

HIGH PRICED EDISONS SELLING.

A. W. Toennies, Jr., of the Eclipse Phonograph Co., Tells of Business Developments.

"The higher priced models of Edison disc machines are continuing to outsell by far the cheaper machines," said A. W. Toennies, Jr., of the Eclipse Phonograph Co., 208 Washington street, Hoboken, N. J., exclusive Edison disc and cylinder jobbers. "The machines retailing from \$150 upward are the types that are meeting with a ready sale in our dealers' establishments, and the demand for this class of goods has naturally created splendid clientele for our patrons.

"April business showed a gratifying increase over last April, although each month so far this year has been ahead of the corresponding 1913 month. The outlook is generally satisfactory, and during the past few weeks we closed contracts with a number of well-known dealers to handle the complete Edison disc line."

A NEW FILING SYSTEM.

The Ogden Invention Meets with Requirements of Talking Machine Men.

The Ogden Record Sectional Unit and Filing System is one which will appeal to talking machine men. This constitutes a complete record filing system and enables the filing of records so that it is possible to locate any desired record instantaneously. It is equipped with spring in each compartment that holds all records in upright position regardless of quantity of records filed. Warping in any way is prevented.

One feature of the Ogden system is the small space required for its big record capacity. It has a large accessory and supply drawer at base. It constitutes a simple, adjustable signal system for quick filing. The manufacturer, J. B. Ogden, Lynchburg, Va., will be pleased to supply descriptive circular and price list to all interested parties.

A number of talking machine men who investigated this system have been pleased with the results.

Sweet, Reed & Housed, who have succeeded the Penna. Music Co. in Williamsport, Pa., report a steadily increased business in Columbia talking machines in their very attractive quarters in the Y. M. C. A. Building in that city. The members of the firm are all progressive men who intend to be heard from.

Philadelphia can be likened to the palm of the shipping hand, for as the thumb and fingers extend, so does the delivery service of

Louis Buehn Philadelphia

cover all important points within several hundred miles of this city. This enables speed in delivery, and you can rest assured that our stocks are as complete as it is possible to get them.

Edison Cylinder and Victor Disc Products

"HOW TO DANCE MODERN DANCES."

Title of an Important Publication Issued by the Columbia Co.—Comprehensive in Its Scope.

The Columbia Graphophone Co. issued this month an important publication entitled "How to Dance the Modern Dances" that should prove one



Illustrations from Columbia Dance Book.

of the most valuable dealer helps the company has ever offered its trade. There is no doubt but that the present-day dances have not yet reached by any means the summit of their popularity and any assistance that is rendered the dealers in developing this profitable field is greatly appreciated.

The new book issued by the Columbia Co. is edited and compiled by G. Hepburn Wilson, M. B., one of the best known dancing teachers in the country and a leading exponent of the modern dances. Mr. Wilson has for some time been supervising the making of all Columbia dance records and it is due in a considerable measure to his careful supervision and detailed knowledge of the present-day dances that Columbia dance records have scored such a country-wide popularity.

The dances presented in this publication include the one-step, hesitation, maxixe and Argentine tango. Mr. Wilson discusses these popular dances as though he were giving private instructions in one of the many artistic studios and every movement is illustrated by pictures which were posed for by Mr. Wilson and one of his capable staff teachers. Every change of step in each of these dances is included in the description of the dance and suggestions as to the proper carriage, position, swing, etc., of the dancers accompany each illustration and general description.

In referring to this new volume a member of the Columbia staff said: "With the completeness of this new dance publication Columbia dealers can offer it to their patrons or prospective customers with the assurance that its careful perusal will give the reader a proper and thoroughly adequate understanding of the most popular modern dances.

"As a dealer help this dance book is entitled to premier consideration in the realm of talking machine literature and the Columbia Co. in offering its dealers this important co-operation is carrying out its fixed policy of giving Columbia dealers every possible assistance in the development of their business and the consistent growth of their profits."

"TALKER" RECORDS FOR HOSPITALS.

The New York visiting committee of the State Charities Aid Association has been making an appeal through the medium of the local press for talking machine records for use in New York City's hospitals and almshouses. Attention is called to the fact that the great majority of institutions have some kind of talking machines, though many more could be used to advantage. There is a great need of records, however, and the committee states that every kind of record is acceptable.



The Columbia automatic stop. The most accurate automatic stop made and the easiest to operate.

Gun Metal, \$2.00 list. Nickel Plated, \$2.50 list. Gold Plated, \$3.00 list.

May be adjusted to both Columbia and Victor disc machines. Order from any Columbia Distributor.

EDISON DISC PHONOGRAPH JOBBERS DINE F. K. DOLBEER

Tender Him Testimonial Dinner at Hotel Knickerbocker—Presented with Chest of Silver—Initiated into Jobbers' Association After Due Ceremonies—A Most Enjoyable Occasion Which Closes with a Lively Session at Churchill's—Those in Attendance.

Frank K. Dolbeer, who recently retired as manager of phonograph sales of Thos. A. Edison, Inc., to assume the management of the Phonograph Corporation of Manhattan, 443 Broadway, New York, received a welcome into the ranks of the Edison jobbers on April 20, when he was tendered a testimonial dinner at the Hotel Knickerbocker by the Edison disc jobbers of the United States and Canada. H. H. Blish presided, and the dinner committee consisted of W. O. Pardee, L. N. Bloom, N. D. Griffin and C. B. Haynes. Men journeyed from Canada, Minnesota, Iowa, Virginia and other far away points to pay a tribute of honor and respect to their old friend, eighteen being present.

After the dinner proper, during the course of which the party was entertained by a pianist and a monologue artist, the candidate, in the person of Mr. Dolbeer was prepared for the ceremony

tory information, and was then shown and advised regarding the details of a new style of Amberola, about three inches high.

There were a number of impromptu speeches and countless tokens of esteem, ending with the presentation of a beautiful chest of silver. Mr. Dolbeer was overwhelmed by this splendid manifestation of friendship on the part of his new associates in the jobbing field, for he is now a full-fledged member of the Edison Jobbers' Association, having been elected unanimously after a very "trying ordeal" and "duly initiated into a knowledge of the Edison line" and its splendid merits.

At the conclusion of the initiation, the party left the Knickerbocker and, following Walter Kipp and his "nanny" goat, paraded up Broadway to Churchill's where tables had been reserved. A pleasing surprise was the presence in Churchill's of Elizabeth Spencer, the well-known singer, who

McKee Surgical Instrument Co., Washington, D. C.; W. A. Meyers Co., Williamsport, Pa.; Milwaukee Phonograph Co., Milwaukee, Wis.; Pacific



F. K. Dolbeer,

Phonograph Co.; San Francisco, Cal., Pardee-Ellenberger Co., Boston, Mass.; F. H. Silliman, Boston, Mass.; W. O. Pardee and H. L. Ellenberger, New Haven, Mass.; The Phonograph Co., Chicago, Ill.; The Phonograph Co., Kansas City, Mo.; Proudfit Sporting Goods Co., Ogden, Utah; Schultz Bros., Omaha, Neb.; Silverstone Music Co., St. Louis, Mo.; Southern California Music Co., Los Angeles, Cal.; Southern Talking Machine Co., Dallas, Tex.; the Phonograph Co., Cleveland, O., B. W. Smith and L. N. Bloom; R. S. Williams & Sons Co., Ltd., Toronto, Ont., H. G. Stanton; American Phonograph Co., Detroit, Mich., E. P. Ashton; American Phonograph Co., Gloversville, N. Y., N. D. Griffin; F. E. Bolway, Sr. and Jr., Oswego, N. Y.; Buehn Phonograph Co., Pittsburgh, Albert A. Buehn; Denver Dry Goods Co., Denver, Col., H. N. Richards, and Eclipse Phonograph Co., Hoboken, N. J., A. William Toennies.

OPENS STORE IN MONTGOMERY.

(Special to The Talking Machine World.)

MONTGOMERY, ALA., May 7.—E. W. Dahlberg, for several years business manager of the talking machine department of the E. E. Forbes Piano Co., has purchased the entire department from this concern. He has opened the Dahlberg Talking Machine Co. at 110 Dexter avenue, this city, where he intends to augment the following, which he has won through his very successful methods in developing business.

AIDS CHURCH FUNDS.

The Koch & Droge Piano Co., well-known Victor dealer, lent a Victrola recently to the Christ Lutheran Church, of that city, which was giving a Victrola concert to raise funds. This concert was a gratifying success, and the company's courtesy and consideration were greatly appreciated by the congregation.

Clarence, you can rest assured that when a man cannot think of anything to kick about it is a sure sign that he is failing mentally.—New Orleans States.

Pattern your facts after dollars. If they ring true and are full weight, they're "legal tender" anywhere.



Well-Known Men at Dinner in Honor of Frank K. Dolbeer.

of initiation into the ranks of the Edison Disc Jobbers' Association and it was a "trying ordeal." First came the election, and, upon opening the ballot-box, it was discovered to have been stuffed outrageously with white and black balls about equally proportioned.

A rising vote, unanimous, made Mr. Dolbeer a regular member of the association without further ado, although he still had to pass through the "second degree." The final degree consisted of being requested to ride a toy "nanny" goat with a large, although artificial voice, in approved lodge style, and then accept a loving cup. The latter was a plain tin cup with three handles, roughly soldered on, and from which all present drank the health of their guest. Having passed through the mysteries of initiation, the candidate was then declared entitled to all inside fac-

has made many Edison records, and who sang a verse directed particularly at Mr. Dolbeer, and paying tribute to his many good qualities, arousing great applause.

It was a great evening, thoroughly informal and exceedingly enjoyable. It shows the esteem in which Mr. Dolbeer is held when men journey thousands of miles to pay him honor. It is indeed worth while living to attain such a position of esteem in the trade world.

The various firms represented at the dinner, greeting, were the Girard Phonograph Co., Philadelphia, R. P. Cope; Harger & Blish, Des Moines, Ia., H. H. Blish; Hayes Music Co., Toledo, O., W. H. Hug; C. B. Haynes & Co., Richmond, Va., C. B. Haynes; Kipp-Link Phonograph Co., Indianapolis, Ind., W. E. Kipp; Lawrence H. Lucker, Minneapolis, Minn.;

Send 50 cents in stamps for sample "Standard Fibre Needle Cutter." The easiest selling accessory ever offered the trade. Appeals to the women buyers. Retains chips. Artistic. Built like a watch. Compact. Powerful. Liberal discounts. Order through your jobber.

**STANDARD GRAMAPHONE APPLIANCE CO.
173 LAFAYETTE STREET, NEW YORK CITY**



Every money-making reason for carrying the Columbia line of records gets a 50% increase in strength by the addition of the new Columbia Double-Disc Dance Records listed in the June supplement (out May 20th).



(Write for "Music Money," a book "full of meat" for those dealers interested in quick and frequent turnover of capital.)

Columbia Graphophone Company
Woolworth Building, New York

ACTIVE DEMAND FOR MACHINES ON THE PACIFIC COAST.

Increased Interest in Talking Machines Attributed to Dancing Craze—Exposition Bringing Many People to City—New Columbia Department Opened at Sacramento—Sherman, Clay & Co. Open Branch with Victor Line in Eureka—New Edison Agents.

(Special to The Talking Machine World.)

SAN FRANCISCO, CAL., April 29.—Various talking machine interests here emphasize the fact that the demand for machines was particularly good the past month. In some instances it is reported that the machine part of the business was almost equal to December, and by others that the machine sales were the best for any month in a long time, with the exception of December. The increased interest in machines is attributed to the continuous appeal to the public to use the talking machine in connection with dancing, the craze for which continues unabated in this vicinity, as shown by the ever increasing demand for the new dance records. Local dealers have reason to anticipate business keeping up fairly well all summer. The exposition is already bringing many people to the city and the work to be done between now and the opening of the fair will require not only the presence of mechanics, but large clerical and executive forces as well to look after the concessions and the installation of exhibits. This, it is expected, will compensate to a large extent for the regular exodus from the city during the vacation season.

Pacific Phonograph Co. in New Quarters.

The move of the Pacific Phonograph Co. to its new quarters in the Sachs Building on Geary street the past month marked a decided forward step for that concern. The new establishment has been fitted up on an elaborate scale for a jobbing business. The building is new and of modern construction, designed specially for offices, so the company was particularly fortunate in securing large quarters in it, occupying, as it does, the entire third floor and nearly all the fourth.

A. G. McCarthy Interested in Exposition.

Andrew G. McCarthy, who looks after the Victor-Victrola part of Sherman, Clay & Co.'s business, as well as Phil T. Clay, is giving considerable attention to exposition work. Both served on the special committee which arranged for the elaborate Phoenix Fête on the grounds May 1, 2 and 3. Mr. McCarthy visited the company's wholesale Victor warerooms in Los Angeles the latter part of April, and reports things in good shape down there. He says all the Sherman, Clay stores did a satisfactory talking machine business the past month, the reports being particularly good from the Northwest.

Lively Columbia Business for April.

W. S. Gray, district manager for the Columbia Graphophone Co., left for the Northwest a few days ago on a short trip with the intention of bringing A. Glenn, manager of the Portland office, who has been ill for some little time, to California thinking that he might improve more rapidly down here. F. R. Anglemeier, who looks after the wholesale end at the local warerooms, says the sales of machines proper for April was almost equal to December, the \$75 and \$100 styles coming in very strong. Record business for the month

was also ahead of the other months so far this year. C. P. Leroy, traveler from this office, has just returned from a trip down the Coast, on which he found dealers enjoying a normal business, and preparing for better times in the fall.

Chas. S. Mauzy Married.

Chas. S. Mauzy, who is associated with his father in the Byron Mauzy music business on Stockton street, having charge of the talking machine department, was married on April 29 in this city to Miss Mildred Alice Dovey. The young couple are now away on a honeymoon trip and upon their return will make their home here. Byron Mauzy reports a very good showing for April in the talking machine department, where Victor, Columbia and Edison products are handled.

New Columbia Department in Sacramento.

A new Columbia department was opened in Sacramento, Cal., the middle of April, by the Wasserman-Gattmann Co., who conduct a general department store business there. The formal opening of the new department was one of the most elaborate events of its kind ever held in that city. Large floor space has been assigned to that part of the business, and a large stock of machines and records was assembled prior to the opening, which was heralded by large ads in the daily papers. The store was specially decorated for the occasion and much interest was shown in the expansion of the business.

Bacigalupi's Good Report.

Peter Bacigalupi, Jr., who operates the Bacigalupi talking machine business, reports a very good business the past month in both Victor and Edison products. He enjoyed an outing the first of the month with Leon F. Douglas of the Victor Co., who resides in Marin County, California.

Better Trade with Kohler & Chase.

P. H. Beck, proprietor of the Kohler & Chase talking machine department, says business for March and April showed improvement over the first two months of the year in both machines and records. Higher priced records are in better demand than for some time, and the \$100 Victor-Victrola is having a big call.

New Edison Disc Dealers.

Several more California dealers have signed up for the Edison disc line recently. They include the Avery Drug Co., Yreka; Sisson Drug Co., Sisson; Hawthorne & Broderman, Long Beach, and the Weed Mercantile Co., Weed.

New Store in Richmond, Cal.

P. C. Hawley has opened a new music store in Richmond, Cal., under the name of the Hawley Piano Co. He has a well-stocked Victor-Victrola department, and is making a strong feature of that part of the business.

Sherman, Clay & Co., Branch in Eureka, Cal. Sherman, Clay & Co., who are distributors for the Victor Talking Machine Co. for the Pacific

Coast, and who retail Victor products at their various branch stores, are opening a new branch in Eureka, Cal., under the management of Geo. C. Dillon, who was connected with the trade in that city some time ago.

The appearance of several artists making records for talking machines on the Coast the past month, including Mischa Elman and David Bisham, has stimulated interest in high-class records generally.

SECURE EDISON DISC AGENCY.

The Flanner-Hafsoos Music House Selected by the Milwaukee Phonograph Co. to Handle Edison Line on East Side.

(Special to The Talking Machine World.)

MILWAUKEE, WIS., May 8.—The Edison disc phonograph line has been taken up by the Flanner-Hafsoos Music House at 417 Broadway, handling the A. B. Chase, Estey, Christman, Lauter, Wegman, Lyon & Healy and Brinkerhoff pianos.

The Milwaukee Phonograph Co., jobber in Wisconsin and upper Michigan for the Thomas A. Edison, Inc., has been desirous of letting one of the east side piano houses carry the Edison goods, and chose the Flanner-Hafsoos house because of its high standing and because it did not carry any other line of talking machines.

A full stock of the Edison goods has been received at the store and is being featured in the windows of the establishment. Florian F. Flanner, junior member of the firm, says that three large parlors will be installed on the main floor so that the Edison line may be featured properly.

The master minds of constructive statesmanship molded the American Government. The master mind of an inventive genius forced Edison to reveal to the world the wonders of electricity.

**PHONOGRAPHISCHE
ZEITSCHRIFT**
BERLIN C. 19, GERMANY

The oldest and most up-to-date trade paper covering the talking machine line published in the German Language.

PUBLISHED WEEKLY. FOUNDED 1900

Circulates all over the world.

SPECIAL EXPORT NUMBERS appear in four different languages at regular intervals.

Subscriptions for this talking machine publication 10 Marks yearly. Sample copies sent free.

FROM OUR EUROPEAN HEADQUARTERS

2 GRESHAM BUILDING, BASINGHALL STREET E. C., LONDON, W. LIONEL STURDY, MANAGER.

Trade Conditions in London and Throughout England Are Certainly Not Overbright—Various Reasons Assigned in Explanation of Sales Slump—Cheapening of Record Prices, Better Quality of Goods and the Class of Trade Indulged Have Been Factors of Moment—German Manufacturers Combine to Fight Price Cutting—A Momentous Move—Scala Record Co., Ltd., Suffers from Fire—Interesting Issues of Records for the Month—New Columbia Artists—Edison Cylinder Records Will Continue to Be Made—News of the Month Worth Recording.

(Special to The Talking Machine World.)

LONDON, E. C., May 2.—Elements adverse to the sale of musical instruments and records have obtained this last few weeks, and not a few traders assert that the period has arrived when the official season may reasonably be regarded as over. One must admit that gramophone trade conditions are certainly not bright; indeed it would really seem that business is, for the time being, suffering under a cloud of depression of unusual duration and strength. Various reasons are assigned in explanation of the sales slump, notably the fine summerlike weather, holidays, strikes and disturbed industrial conditions generally, all of which does not militate in favor of sales progress.

The aftermath of the shilling record proposition has also contributed largely to an unsettled market, payments being exceptionally bad, and credit doubtful in several cases. Confidential information discloses anything but a pleasing prospect in relation to the future welfare of some of the cheap record houses. The class of trading indulged in has been all along more or less unprofitable, and the inevitable consequence is gradually yet surely making itself felt. Leading gramophone men and others whose interest in the talking machine trade is more than superficial, regard the situation as being very unsatisfactory, alike from the viewpoint of its immediate as well as its ultimate effect upon an already severely tried market. I have it on unquestionable authority that a deal was recently made in good double-sided records at the remarkable figure of four pence halfpenny each, this price including copyright dues and freightage. Such amazing evidence as this is clear indication that the cheap record proposition is still a live one. Far from nearing its doom, it is a bright hope within whose comforting protection many a financially depressed house may (on paper) temporarily recover a questionable equilibrium. For how long necessarily depends upon circumstances. One or two have already piled up their obligations, and news is not wanting of the closing of other firms within the near future. Financially exhausted, these latter are existing from day to day more or less indifferent to what the morrow may bring forth. It is altogether an unedifying situation, and we can but fervently hope that next season may commence with a clean bill of health for the good of the whole trade. From a report elsewhere it will be seen that the leading German gramophone houses have associated together with a view to serious co-operation in fighting the price cutting, record duplication and other trenchant evils which have for too long hampered the progress of an otherwise growing industry. When will the British trade do likewise?

To Fix Record Prices in Germany.

An important development in German record manufacturing circles is made known by our esteemed contemporary, the Phonographische Zeitschrift. The report gives currency to the formation of an organization consisting of the large manufacturing firms in Germany whose object is the fixing of retail prices for records and the regulation of other important trade matters of general effect. While this arrangement assures to all sections of the trade a reasonable profit, it in no way places a premium on competition, except in so far

as may result from a rather peculiar clause affecting the yearly profits of each concern. This point is really interesting; it stipulates that "should the record output of any one maker exceed in 1914 the production of 1913, for every record over the value of 2.20 marks, 20 pfennig must be paid into the convention cash account for distribution among those firms whose turnover shows a decrease." A remarkable idea, to say the least. It has too many possibilities. However, we read that competition will be mainly confined to the quality of the records. A number of firms have refrained from joining the Convention of Manufacturers, as it is called, but they are at liberty so to do if they wish. It is intended to control the various distributing sources, and to this end a list of factors and dealers has been prepared. Although each manufacturer has a free hand in the choice of wholesale distributing agencies, no one must be supplied outside the agreed list. An agreement also covers the relations of the manufacturers and the chosen retailers, the gist of which is that the latter bind themselves to handle exclusively the productions of associated makers, who include the following important companies. Deutsche Gramophon, International Zonophon, Carl Lindstrom, Beka, Favorite, International Talking Machine, Odeon, Lyrophon, Dacapo, Homophon, Anker, Kaiuope and Polyphon Musikwerke. For the different makes of records a standard price agreement has been drawn up and ratified by the convention, which has also sanctioned a limit being placed upon the number of records to be issued per month by each concern. Another clause provides for the regulation of wholesale and retail profits, and the practice of annual or bi-yearly exchanges is considerably revised. Unsalable records may, however, be returned for partial credit under certain prescribed conditions. For breaches of the agreed terms and stipulations a system of fines has been instituted. The convention agreement operates as from July 1 next, and remains in force for twelve months. Leo. B. Cohn, H. Eisner and Mr. Seligsohn are entrusted with the management of this praiseworthy endeavor to clean the Augean stable.

New Hearing in Big Copyright Case.

The adjourned proceedings in the great copyright case (reported in my last contribution) again came on for hearing before Mr. Biron, the magistrate, at the Old street police court, London. Defendants were William Jennings, trading as the Runwell Cycle Co., of 16 Great Eastern street; Blum & Co., Ltd., of 220 Old street, and W. H. Reynolds, Ltd., of 95 Great Eastern street, all of London. There were four summonses against each defendant for "unlawfully and knowingly offering for sale an infringing copy of a copyright work, contrary to the provisions of the Copyright Act, 1911." The subjects of the summonses were records of "The Gondoliers," "Pipes of Pan," "The Lost Chord" and two other songs. Through their counsel the Runwell Cycle Co. and W. H. Reynolds, Ltd., pleaded that they were not the makers of the infringing records, and as dealers they did not "knowingly" offer them for sale and could not therefore be held responsible in law. After very considerable legal argument this view was eventually accepted by the magistrate, whose finding clearly demonstrates that a dealer cannot be mulcted in damages for selling records without a copyright stamp unless it is proved that he did so "knowingly." The case against Blum & Co., Ltd., as manufacturers of certain of the records proceeded after an adjournment to another court. The summonses were taken out by the Mechanical Copyright Licensees Co., Ltd., whose counsel succeeded in making good their complaints in three instances, although defendants brought evidence that the records in question were circulated by accident. The magistrate said he considered the case proved and imposed a penalty of 40 shillings on each of the three summonses, with

£10 costs. An order was made for delivering up of the unstamped records and masters, which, it was said, had already been destroyed.

Scala Record Co. Suffers Fire Loss.

The premises of the Scala Record Co., Ltd., 80 City road, London, were the scene of a somewhat serious fire on the afternoon of April 27. Just after the luncheon hour flames were discovered issuing from the basement, which contained a large stock of records, gramophone cabinets, wooden trumpets, motors, etc. A strong contingent of firemen with their engines and apparatus were soon at work, but owing to the dense black smoke, attributed to the burning records, by the way, it became necessary for several men to descend into the basement and so secure a direct attack on the flames. For this purpose smoke helmets or breathing apparatus were utilized, and as soon as possible men with powerful hydrants got to work. By this time the basement and ground floor had been very severely damaged. After an hour's hard work, however, the firemen gained control and completely extinguished the outbreak. The damage to premises and stock is roughly estimated in the neighborhood of four figures. Messrs. Lockwood's premises situated next door to the burnt building, fortunately escaped, apart from some slight damage from smoke and water.

Your representative arrived on the scene early, and afterward was enabled to make what was necessarily but a superficial survey of the damaged building. Everywhere was confusion and wreckage. A more complete examination on the next day revealed the power of fire and water. To wreak such havoc as was apparent in so short a time as sixty minutes was really surprising. The basement had received over four feet of water; the floor was still slightly covered, and piles of half-burnt stock, soaking wet, were to be seen all around. At the time of writing the actual cause of the fire had not been ascertained and no information was available beyond the fact that it had originated in the basement, where it is believed some wood shavings used for packing purposes caught fire.

Harold Bosman, a director of the Scala Record Co., informed your representative that he had received many expressions of sympathy and offers of help from the trade. He was very much indebted to Mr. Cullum, proprietor of Lockwood's, for assistance rendered, his many kind acts going a long way toward mitigating the great business inconvenience caused. O. Ruhl, Ltd., also gave great assistance and has offered the Scala Co. the use of a warehouse for the time being.

From later evidence it is obvious that the Scala officials mean to lose no time in straightening out matters so that business may be as little interfered with as possible.

New Summer Model of "H. M. V." Machine.

A special summer model of extreme value at the price, 6 guineas, is announced by "His Master's Voice" Co. Of particularly handsome appearance, this new instrument carries the following specifications: Fumed oak cabinet 16¾x20¼ inches (height 12¾ inches), with lid; internal horn with wooden grille; double-spring motor; "H. M. V." tapered tone arm with gooseneck and exhibition sound box, etc. It makes a fine table-grand machine and should be an excellent line for summer trade.

The news was not conveyed to dealers in the ordinary way; it reached them by registered letter post. A smart and enterprising idea, without a doubt, for it is questionable whether any other method would have aroused such great interest in the new article as that adopted. One expects "value" by registered package; "H. M. V." dealers say they've got it.

Short Time from Sydney to San Francisco.

The announcement is made that from June next

(Continued on page 54.)

ARRIVED AT LAST

"The World's Musical Instrument"

Gives *all* records the same chance!

SOON ON THE MARKET.

✿

Sounds
that are
truly
MUSICAL!

✿



✿

Voices
that are
truly
HUMAN!

✿

PLAYS TO PERFECTION,

without change of sound-boxes, EVERY disc record ever made and in such a realistic manner as never heard from any "Talking Machine," "Gramophone" or "Disc Phonograph" before.

(Read the views of the able Representative of this paper in London, about this new Instrument, on page 45 of March 15th, 1914.)

J. HOFFAY

67 Egerton Gardens, South Kensington, London, England.

IN THE PAST

A certain reproducing instrument brought its owners success and fame—it was about the best!

Competitors did not possess the same reproducing means to show off their records, which perhaps were just as good.

Dealers were compelled to bind themselves!

IN THE FUTURE

“The World’s Musical Instrument”

will sell, on equal merits, records of ALL makes.

All competitors will have the same means to “fight” with, and “quality” in recordings will predominate exclusively.

Dealers will surely stock all makes.

Dealers will surely gain their liberty.

Dealers will surely dominate the field.

Ask for catalogues, etc., at once.

J. HOFFAY

67 Egerton Gardens, South Kensington, London, England.

FROM OUR LONDON HEADQUARTERS—(Continued from page 51).

the new vessels of the Oceanic Steamship Co. will perform the journey between Sydney and San Francisco in sixteen and one-half days, and that, linked up as they are with the express boats of the Cunard and other Atlantic lines and by the mail trains of the United States, a great saving of time all around will be effected.

In Voluntary Liquidation.

The Britannic Record Co., Ltd., of City road, London, has gone into voluntary liquidation. The liquidator is Joseph Misener, 205 Willesden lane, London, N. W.

Be a Record Business for 1913.

Advance information anent the Beka Record, A. G., turnover for last year is published by a German contemporary. The figures quoted disclose a net profit of 593,910 marks, after deducting 121,977 marks for working expenses. At the general meeting a dividend of 12 per cent. is to be proposed.

German Record Concern in Liquidation.

The Jumbo Record Fabrik, G. m. b. H., Berlin, is in voluntary liquidation. Richard Seligsohn, the former manager, has been appointed liquidator.

Performing Rights, Ltd., Organized.

Apropos of the formation of the new corporation, Performing Rights, Ltd., I learn that a somewhat similar move has been made by the American publishers and authors, who have registered a company with the title American Society of Authors, Composers and Publishers. Both societies will be run on similar lines to the Societe de Authors in Paris. The objects are the collection of fees for performing rights and like royalties. I believe I am correct in saying that the three societies will co-operate for the mutual protection of their members' interests in the various countries in which each society operates.

Latest "His Master's Voice" Records.

In the latest batch of record issues announced by "His Master's Voice" Company for May, the live agent will, undoubtedly, find much upon which to justify a special campaign; a special effort to make known the magnificence of these records to

the great gramophone public. It is certainly a grand musical program, and we are assured it will make a very wide appeal alike on account of its general merit, and its comprehensive choice of titles. A special feature of the list is an exceptionally strong presentation of Russian music, sung by native artists, and these record offerings one may reasonably expect to create quite an unusual amount of interest. A careful perusal should be made of the full program as follows: 12-inch, double-sided—"Bavarian Dances, Op. 27, No. 3 (Elgar), and "Mignon Overture" (Thomas), Bournemouth Municipal Orchestra; "Ent'r Acte à la Gavotte" (Eric Coates), and "Sunshine and Shadow," waltz, (W. Piercy), Mayfair Orchestra; "Prince Igor," Overture, Parts I. and II. (Borodin), Borodin Symphonic Orchestra; "Sur la Riviera" (Daniderff), Jacobs and his Trocadero Orchestra, and "Verviene Valse" (Robt. Cox), Mayfair Orchestra. 10-inch double-sided—"Bobbing Up and Down" and "International Rag" (Irving Berlin), Metropolitan Band; "Patria Jova" (A. Marcet), and "La Vica de Casa" (E. Morera), Spanish Band of La Principal del Prelada. 12-inch single-sided—"Fifth Symphony," First Movement, Part I. (Beethoven), Berlin Philharmonic Orchestra; "Fifth Symphony," First Movement, Part II. (Beethoven), Berlin Philharmonic Orchestra; "Der Erl König" (The Erl King) (Loewe), (Sung in German), Dr. George Menschel (bass); "Nobody Else" (Crimp), Miss Alice Lakin (contralto); "Who Can Tell Me Where She Dwells," ("Rob Roy," Act 3), (R. de Koven), Wakefield and Pollock; "Valse-Coppetia Ballet" (Déliibes), Lipkowskaya (Russian soprano), (Sung in Russian); "Les Filles de Cadiz" (Déliibes), Neshdanava (Russian soprano), (sung in Spanish); Aria from "A May Night"—"Sleep My Beauty" (Rimsky-Korsakoff), Smirnoff (tenor), (sung in Russian); "Arise, Red Sun" (Russian Folk Song), Chaliapin (bass) (with chorus), (sung in Russian); "The Devout Lover" (M. V. White), Stewart Gardner (baritone); "Prize Song—Meistersinger" (Wagner, aria by A. Wilhelm),

Mischa Elman (violin); (a) "Study, Op. 10, No. 7," (b) "Waltz in D flat" (Chopin), Wilhelm Backhaus (piano); "Lack-a-Day" (Crampton), Ernest Crampton. 10-inch, single-sided—"A Farewell" (Liddle), John McCormack (tenor); "Song of the Shepherd Lehl," "Snow Maiden" (Rimsky-Korsakoff), Alma Gluck (soprano); "Come to Me" (Wadham), Hubert Eisdell; "Thou Art Risen, My Beloved" (Coleridge-Taylor), Robert Radford (bass); "A Rose Memory" (Deacon), John Harrison (tenor); "My Fairy Prince" ("Her Little Highness") (R. de Koven), Olive Kline (soprano); E Lucevan le Stelle "Tosca" ("The Stars Were Shining") (Puccini) Martinelli (tenor), (sung in Italian); "A Hundred Years Ago" (Crampton), Ernest Crampton.

New Zonophone Records.

This month's (May) Zonophone records comprise an exceptionally well chosen program of good music with a plentiful sprinkling of each class: classical, sentimental, humorous, etc. The famous Royal Irish Fusiliers Band is again in evidence with a superb contribution, "The Jolly Village Smith," coupled with which is the waltz song "Il Bacio," as a cornet solo by Corp. Williams. Another special is record No. 1281, containing two pretty songs by Sidney Coltham, the great Zono tenor who has in a few short months secured renown as a record-maker of exceptional merit. A really good banjo duet record is listed as the work of "the world's greatest duettists," Alfred Cammeyer and Oly Oakley. In addition, there is to be noted exclusive contributions by Miss Violet Oppenshaw (contralto), Mary Law (violin), Black Diamond Band, Peerless Orchestra, Peter Dawson, Church Choir with Organ, Florrie Ford, Harry Fay, and other favorites.

Has Many Popular Songs.

"Hullo Tango!" the London Hippodrome Revue is most prolific in its provision of attractive songs, and the various record companies have, naturally, been very busy. "His Master's Voice" company, as usual, has secured the original artists to make



To T.M. the King and Queen of Spain



To H.M. the King of Sweden



To H.H. the Khedive of Egypt



To H.M. the King of Italy



To H.M. the Shah of Persia



By Appointment To H.M. Queen Alexandra

"His Master's Voice"

—the trade-mark that is recognised throughout the world as the

Hall-mark of Quality

AUSTRIA: Oesterr. Grammophon-Gesellschaft, m. b. H., 8, Krugstrasse, Vienna.
 BELGIUM: Cie. Française du Gramophone, 51, Avenue de la Porte de Hal, Brussels.
 DENMARK: Skandinavisk Grammophon-Aktieselskab, Frihavnens, Copenhagen.
 FRANCE: Cie. Française du Gramophone, 115 Boulevard Richard Lenoir, Place de la République, Paris.
 GERMANY: Deutsche Grammophon-Aktiengesellschaft, 35, Ritterstrasse, Berlin, S42.
 HOLLAND: American Import Co., 22a, Amsterd. Veerkade, The Hague.
 HUNGARY: The Gramophone Co., Ltd., IV, Kossuth Lajos-Utca 8, Budapest.
 SPAIN: Cia. Francesa del Gramophone, 56, Balmes, Barcelona.
 SWEDEN: Skandinaviska Grammophon-Aktiöbolaget, 52, Appelbergsgatan, Stockholm.

RUSSIA: The Gramophone Co., Ltd., 45, Nevsky Prospect, St. Petersburg; 9, Golovinsky Prospect, Tiflis; 30, Nowia Swit, Warsaw.
 EGYPT: The Gramophone Co., Ltd., 13, Rue Stamboul, Alexandria; Rue Mousky, Cairo.
 EAST AFRICA: Bayley & Co., 8 Beira, Lourenço Marques.
 SOUTH AFRICA: Darter & Sons, Adderley St., Cape Town; Mackay Bros., Rissik Street, Johannesburg; Mackay Bros. & McMahon, 443, West Street, Durban; Ivan H. Haarburger, Maitland St., Bloemfontein.
 INDIA: The Gramophone Co., Ltd., 139, Balliaghatta Road, Calcutta; 7, Bell Lane, Fort, Bombay.
 AUSTRALIA: The Gramophone Co., Ltd., Hoffmungs Chambers, Pitt Street, Sydney.
 GREAT BRITAIN: The Gramophone Co., Ltd., 21, City Road, London, E.C.



Great Britain:

The Gramophone Company Ltd
 21 City Road London EC

FROM OUR LONDON HEADQUARTERS—(Continued from page 54).

some sparkling records of the most popular numbers, and these were recently announced in a special colored supplement, fully illustrated, and most pleasingly produced.

Two New Columbia Artists.

Two more big names are added to the Columbia catalog this month, and, in each case, an especially fine record serves as introduction. The celebrities in question are Madame Carolina White, the prima donna soprano of the Philadelphia-Chicago Opera Company, and Henri Scott, the famous American basso. Mr. Scott is the leading basso of the New York and Philadelphia-Chicago opera houses, and is known for the exceptionally deep and rich timbre of his voice, features which immediately strike the hearer of his first record carrying "The Heart Bowed Down" and "In Happy Moments."

To Continue Making Edison Cylinder Goods.

Concerning the rumors in trade circles that the Edison Co. would ultimately abandon the manufacture of phonographs and records, Mr. Walter Stevens, manager of the foreign department of Thomas A. Edison, Inc., very strongly disclaims any such intention. He writes (in part)—"We wish to deny this most emphatically. The confidence of this company in a continued demand for the Edison cylinder product is proven by the enormous investment we have made in recent months in the improvement of this line and the further expenditures now being made. We believe this assurance will dispel any uncertainty existing in the minds of our friends abroad regarding our future policy. We expect to push the sale of the Blue Amberol record and Edison phonographs with renewed vigor * * * In a recent interview with your representative, A. F.

Wagner, the British manager of the Edison Co., made pertinent reference to the fact that while all cylinder business was being conducted direct from the States, it had not in the slightest degree militated against British trade interests. "As a matter of fact," continued Mr. Wagner, "we are doing a very large and satisfactory business, and I believe that for many a year to come, the Edison phonograph and records on musical merit and as a sales proposition will continue to offer dealers a lucrative field for development."

Columbia Record Notes of Interest.

The announcement of a record by Ivor Foster on Columbia-Rena this month is an interesting event, for Mr. Foster is an old Columbia friend, his first introduction to the record world being, if we remember rightly, on Columbia some nine or ten years back.

In the Columbia May list we have such great names as the Scots Guards Band, the Ellery Band, Hans Kronold ('cello), George Barrere (flute), Anderson Nicol and Gertrude Woodall in duets, Ivor Foster, H. Lane Wilson, Thorpe Bates, Cooper Mitchell, and others.

Henry Burr, the famous American tenor, is announced on this month's Columbia-Rena records in a beautiful song "Sing Me 'The Rosary,'" founded on the Nevin's famous melody, and in a barcarolle duet with Miss Clara Moister.

Another of the two-part orchestral records, for which Columbia-Rena has become famous, is announced this month. It provides Weber's wonderful "Der Freischütz" Overture, the opera thus represented having been termed the foundation of German opera.

The first ten-inch record of Sir Edward Elgar's much-talked-of new work, "Carissima," is issued

on Columbia-Rena this month. It has interested a great many buyers of high-class music.

The Milan Symphony Orchestra, under Maestro Romani, has created a new monument to Columbia recording quality. This month's issue should be even more popular, for while the previous records have shown the orchestra in delicate work, this record displays the players in "Lohengrin" and "Tannhauser" selections calling for power and volume, and the most exacting critic on these points will find he has all he could wish.

H. Lane-Wilson, the celebrated baritone, sings on Columbia-Rena this month, his own new song, "Before You Came."

"Deiro, the marvelous," the Italian wizard of the accordeon, offers two dashing march selections ("Bersaglieri" is one of them) as his Columbia-Rena contributions this month.

Reed Miller, the popular American tenor, is represented by a twelve-inch record of oratorio on Columbia this month. He sings "If With All Your Hearts" and the companion aria "Then Shall the Righteous," from "Elijah."

Cristeta Goni, the fourteen-year-old violinist, whose first record on Columbia-Rena last month caused quite a flutter in the trade, will be found on a twelve-inch record this month, in a "Nocturne" of Ambrosio, and Drdla's "Serenade."

Three further remarkable records are issued in the Columbia "Grand Opera at a popular price" series this month. One is the celebrated Polverosi in "La donna e mobile" and "Questa o quella," another two "Barber of Seville" numbers by Coradetti, and the third two "Dramatic Moments" from "Aida," to-wit, the consecration scene in the temple of Fta, and the concerted piece sung in honor of the sacred Nile.

BUSINESS LIVELY IN BELFAST.

Talk of "Revolution" and Home Rule Question Does Not Interfere with Business—Talking Pictures Much in Evidence and Are Successfully Shown at Panopticon Theatre.

(Special to The Talking Machine World.)

BELFAST, IRELAND, May 1.—Despite the talk of "revolution" and troublesome times over the Home Rule question, business goes on uninterruptedly in this city. This is particularly true so far as the talking machine trade is concerned, which is constantly expanding.

Talking pictures are now very much in evidence in all the picture theatres, and one of the most successful combinations of picture and Gramophone is that which has been in evidence at the Panopticon Picture Theatre situated on High street. For the purpose the proprietor, Frederick Stewart, has adopted the celebrated Auxetophone which he secured from Thos. Edens Osborne, of 11 Wellington place, who carries one of the largest stock of talking machines and records in the north of Ireland. The cabinet of this instrument is of Flemish style and is of Spanish carved oak, the selling price of which is £110 (\$550). The Auxetophone, by the way, is the invention of a celebrated Irishman, the Hon. Chas. Parsons, of Turbine engine fame.

The reproduction of Gramophone records by this instrument is loud, clear and distinct, and every word—in fact, every syllable—can be heard distinctly throughout the entire picture theater. The synchronization is remarkably good, and the habits of the Panopticon seemed to be all charmed not only with the instrument but with the pictures shown in conjunction with the Auxetophone, which is the most expensive and loudest disc talking machine in the world.

THE "WIZARD" HOMOPHONE.

A new harmony gramophone, called the "Wizard" Homophone, has been put on the market by Andres Bro. Ltd., of London. It is a portable horn-hidden instrument, constructed of dark colored wood and is fitted with a 10-inch turntable, speed regulator, spring brake and a strong and very silent running board. One of the prominent characteristics of the machine is the reflex horn,

which is devised in the lift up cover of the cabinet. The instrument emits a surprisingly clear and full tone and is expected to be a popular seller.

SEES BOUNTIFUL BUSINESS.

C. H. Bagshaw Looks for an Enormous Trade in Needles the Present Year Owing to the Dancing Craze Which Is Steadily Growing.

Asked to give his opinion on the remaining months of the year's business on talking machines, C. H. Bagshaw, general manager of W. H. Bagshaw, Lowell, Mass., the big talking machine needle house, said:

"From my observation of the industry, I can see nothing but a very bountiful business for both manufacturers and dealers, in 1914. The craze for dancing has demonstrated the versatility of the talking machine, and indications point to the fact that this craze will not die out for a long while. As far as the needle business goes, this bears out what we say, and the orders, now on our books, show that there will be a great many more needles used this year than ever before. I can see nothing but prosperity for the talking machine industry, not only for the balance of this year, but for many years to come."

Occasionally a man can be judged by the company he keeps away from.

TRIUMPHON Co., Ltd.
ESTABLISHED 1884
Berlin, S. W., 47/5
MANUFACTURERS
OF ALL ACCESSORIES SUCH AS

MOTORS

10 different models, ready and complete to be fitted into cabinets. From the cheapest to the best.

40 DIFFERENT MODELS

SOUND BOXES

for Gramophone or Edison Cut Records. First-class workmanship.

TONE ARMS

For Horn and Hornless Machines. To fit all size cabinets.

COMPLETE TALKING MACHINES WITH AND WITHOUT HORN

Apply for Catalogues



Piccolo is a complete Talking Machine. Easily to be carried like a portmanteau. Most suitable for picnic or rover parties in summer, and easily carried to social gatherings in winter. Plays 12-inch records. Is not a toy. Weight without records only 5 kg. Measurements: 11x13¼x7¼ inches.

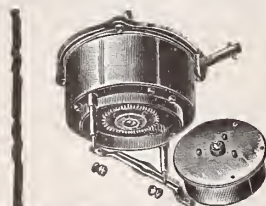

Special Motors HYDRA SYSTEM

Single and double spring, 6 different models. Are the only existing construction which allows the exchanging of the spring and spring case without taking the motor out of the cabinet. After loosening one nut, a child is able to replace any defective spring or springbox within 20 seconds.

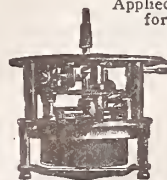

Patents Applied for.



ECLIPSE PHONOGRAPH COMPANY

203 Washington Street

A. W. TOENNIES & SON

Hoboken, N. J.

Jobbers of Edison Disc and Cylinder Phonographs Exclusively

Dealers of New York and New Jersey
Write for terms and discounts.



COLUMBIA STAFF ENJOYS DANCE.

Heads of Departments and Employes of Executive Offices of the Company Participate in Informal Affairs at St. George Hotel, Brooklyn—Demonstrate Finer Points of Terpsichorean Art Like Famous Dancers.

There were sounds of revelry and great joy at the St. George Hotel, Brooklyn, N. Y., on the night of April 27, when the heads of departments and the employes of the Columbia Graphophone Co.'s executive office in the Woolworth Building

most important virtues of this brand of music is that you can get all the encores you want without being obliged to persuade or placate an obdurate orchestra leader.

The Columbia executive staff and employes gave a splendid account of themselves in the performance of the terpsichorean art, and it was a very small percentage indeed of those present who decided to watch the dancers in preference to participating. Usually the heads of the departments were to be found dancing the hesitation or the one-step with the best of the younger folk, and in

flavor was given the event by the appearance of three of the company's European representatives, F. Passadora, Louis Sterling and Arthur Brooks.



Portion of Columbia Staff Enjoying Dance at St. George Hotel, Brooklyn.

gathered at this prominent hostelry to participate in an informal dance.

The music furnished for this enjoyable affair was exclusively Columbia, consisting of dance records and a Columbia machine, and in the opinion of all those present it was "some music." Almost every dance was encored, and one of the

fact everybody had such a good time that another dance will be held in the very near future.

President Easton had intended to be present, but was prevented at the last moment from attending. Edward N. Burns, vice-president, put in five hours of steady dancing, and H. L. Willson, assistant general manager, did the same. Quite an international



No. 1—New England—dignified but sprightly and always educational. No. 2—The English delegation. No. 3—Piracy and highway robbery. No. 4—Export Department providing American-Mexican entente. No. 5—Scientific dancing by Advertising Department. No. 6—Recording Department, strenuous and conscientious.

The export department sent a strong representation from Latin-America. Every department was well represented, and many came as personal guests of the Columbia folk or friends of the company.

Theodore Novakoski, of the treasury department, and Prof. Frederic Goodwin, of the educational department, were in charge of the arrangements for the dance, and both gentlemen did their work well.

Time is like a typewriter eraser. It rubs out our disagreeable experiences—but leaves the paper of life thinner in that particular spot.



"DOLLAR" MOTORS

LATEST SENSATION—DETACHABLE SPRING CAGE

Without any dismantling of the motor, a NEW SPRING may be inserted within a few seconds.

Many patents both at home and in every civilized country applied for.

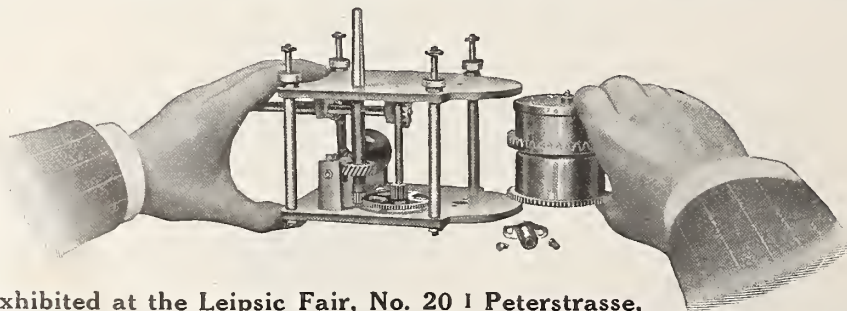

Exhibited at the Leipsic Fair, No. 20 1 Peterstrasse, Hotel de Russie, Zimmer No. 6.

ARE UNQUESTIONABLY THE BEST AND CHEAPEST

Our Export Catalogue in four languages, covering 30 styles of motors adapted for Talking Machines, sent free of charge, postage prepaid, for the asking.

Advantages of our Motors:
Noiseless movement
Supreme accuracy
Highest grade of materials
Greatest money value

GEBRÜDER STEIDINGER, Fabrik für St. Georgen (Schwarzwald), Deutschland
Feinmechanik

Cable Address: Gebrüder Steidinger Sanctgeorgenschwarzwald.

TENDENCY TOWARD IMPROVEMENT IN CLEVELAND

Noticeable in All Branches of Talking Machine Trade—The Phonograph Co.'s Expectations Being Realized—Various Dealers Report Great Demand for Victors—Columbia Co.'s New Store—Call for Union Specialty and Plating Co. Products.

(Special to The Talking Machine World.)

CLEVELAND, O., May 9.—Conditions in the talking machine business have remained about the same and are still in an unsettled state, although there is an evident tendency toward improvement. In spite of deterrent conditions, the aggregate volume of business in both machines and records in April was generally satisfactory, notwithstanding a shortage in the Victor line.

The demand for the May records is excellent. This includes the Victor, Columbia and Edison lists, and sales are expanding.

When John McCormack, the celebrated tenor, was in the city recently he made it a point to visit the Eclipse Musical Co., where he was entertained with his own Victor records. He is an appreciative listener to his own productions, as well as are the thousands of his admirers. The Eclipse people were highly pleased with his visit.

A. W. Robertson, for a number of years with the local Columbia store, is now with the William Taylor, Son & Co.

The business expectations of The Phonograph Co., distributor of Edison phonographs, are being more than realized. L. N. Bloom, secretary, said: "Both in the wholesale and retail line business was very good during the past month. There has been a big demand for dance records. Dealers all through the State are ordering heavily. The dancing parties held in our beautiful recital hall drew the society people of the city, and it was necessary to hold two sessions daily to accommodate the crowds." Harold E. Moore, who for a number of years was manager of one of the largest talking machine houses in London, has joined the store's selling force.

The Eclipse Musical Co. reports business good in both the wholesale and retail departments. Mr. Towell says the annoyance of a shortage in both machines and records still continues. The company has just added a new auto truck to its service. It is very attractively finished and painted, showing the Victor dog in a most life-like form. The company gave a complimentary concert on the evening of May 6, the program consisting of selected Victor records interspersed with selections by a quartet of local note.

Business is moving along smoothly and prosperously at the new quarters of the Columbia Graphophone Co. Having disposed of the retail department to the Grafonola Co., the Columbia is now confining operations exclusively to the wholesale trade and the Dictaphone. All Columbia dealers appreciate the change in the policy of the Cleveland store. The new quarters are most thoroughly equipped for conducting the business, being convenient for handling stock and ideal for receiving and shipping. "We can fill all orders the same day received," said G. R. Madson, manager, "and give dealers practically 100 per cent. efficiency in filling orders."

The following new dealers are reported in the Cleveland territory: O. B. Marvin & Co., Findlay; F. E. Shaw Piano Co., New London; the Gentz Co., Canal Dover, and the Grossman Drug Co. (three stores), Cleveland.

"Yes, I know people say business is slack," said E. A. Friedlander, manager of the Bailey talking machine department, "but our business is considerably better than it was a year ago."

Ethel M. Volk, manager of the May Co.'s phonograph department, is busy these days and reports that business is excellent both in machines and records.

Business at the new store of the H. M. Brainard Piano Co. has opened in the most satisfactory manner. The store is particularly attractive and is located in the new piano center of Cleveland, on Euclid avenue at the junction of Huron road. One-half of the store has been dedicated exclusively to the Columbia graphophone machines and records. The sound-proof demonstrating booths of heavy plate glass, the top border of art glass, with the invisible lighting system and elegantly furnished, are especially attractive. This department is under the management of G. E. Morton, who comes to Cleveland from the Columbia Graphophone Co., of Atlanta, Ga. The company has retained from the local Columbia store force Miss Letha Touby, J. H. McClelland, Earl Hamler and Miss Martha Francek. The company features in pianos the Kranich & Bach line, which is notably popular here. The officers of the company are: H. M. Brainard, president; F. J. Ott, vice-president, and George M. Ott, secretary and treasurer.

Considering business conditions generally, trade at the store of the W. F. Frederick Piano Co. was very satisfactory. "Quite a large number of Victor machines have been sold during the past month," said N. H. Cook, manager of the talking machine department, "and the demand for records, especially from the dance lists, is quite up to the average."

Phil. Dorn, while apparently immersed in the sporting goods line of the Collister & Sayle Co., is watchful of the talking machine department, and his judgment of the condition of that business is always pretty accurate. Business, he says, is coming along all right, although a little slow owing to the inability of the manufacturers to supply the increasing demand. He reports trade equally good in both the wholesale and retail departments.

Business is fair in the Victor machine line, with a good record trade, at Buescher & Sons Co. W. J. Roberts, Jr., who has been with the company for some time, has resigned to engage in other business.

The Grafonola Co., successor of the Columbia Phonograph Co.'s retail business, is doing fine. C. A. Routh, manager, said: "Business is exceed-

ing our most sanguine expectations. Our trade is increasing day by day, and we are meeting with wonderful success. The popularity of Columbia machines and records judging from our sales, is unquestioned."

The large and growing clientele of the B. Dreher's Sons Co. is the result of persistent effort and a liberal publicity policy, backed with a complete stock of Victrolas and records in connection with its piano trade. William G. Bowie, manager of the talking machine department, is quite optimistic in view of the increase of business thus far this year. He reports sales of a number of machines during the past month, with good sales of records.

There is an ever increasing number of side line dealers who are adding the talking machine to their business, and all are having a promising trade.

The Union Specialty & Plating Co. is as busy as ever supplying the trade with the Union attachments. Mr. McNulty says the business is constantly expanding to surprisingly large proportions.

BIG BUSINESS IN ALTOONA, PA.

Occupancy of New Warehouse Marks Progress of W. F. Frederick Co. Store Under Manager Nestor—Immense Victor Stock Carried.

(Special to The Talking Machine World.)

ALTOONA, PA., May 8.—The local branch of the W. F. Frederick Piano Co., under the energetic management of French Nestor, is now fully settled in its commodious new five-story building at 916-20 Eleventh avenue, which will be used as a storage house annex to the retail store of the company at 1208 Eighth avenue. The new building will be used chiefly for the storage of Victor talking machines and records, in which the company does an enormous business as distributor and retailer.

The first floor of the building contains, besides the offices of Mr. Nestor and his assistants, the garage and shipping department, the commodious record rooms, containing racks measuring 180 feet in length and 8 feet high, which are designed to hold about 75,000 records when the stocks are complete. The second and third floors are given over to the storage of machines of various models, cabinets and accessories.

One of the interesting features of the new building is the completely equipped repair and tuning department on the fourth floor, which equals many smaller factories in the facilities. The machinery equipment is up to the minute and is driven by individual electric motors.

The success of the Frederick Co. business in this section is especially noticeable since Mr. Nestor became manager about two years ago, during which time the business of the company has increased wonderfully throughout central Pennsylvania.

Habit and appetite are products of the mind. Bad habits and abnormal appetites are formed either by a weak or an unorganized intellect. Habits are of man's own making because he has the power to organize, train and strengthen the mind that forms the habit.

HERMANN THORENS, Ste. Croix (Switzerland)

TALKING MACHINE WORKS

Motors and Sound Boxes a Specialty

CONCEDED TO BE THE BEST MANUFACTURED

OVER THIRTY DIFFERENT STYLES

Machines with or without Horns

FIRST QUALITY ONLY

Noiseless Motors

HIGHEST RECOMMENDATIONS

WRITE FOR DESCRIPTIVE CATALOGUE

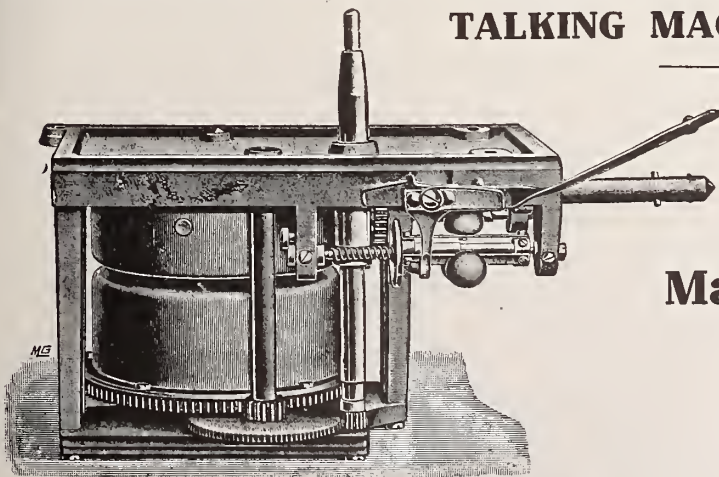

COLUMBIA GRAPHOPHONE CO.'S 25th ANNIVERSARY

The Occasion of a Most Interesting Reunion and Dinner of the Directors, Officials and Executives of the Company Held at the Arcola Country Club, Arcola, N. J., on Saturday, April 11—Some Interesting Remarks by President E. D. Easton and Others.

There was a large and festive noise, indicative of much jubilation, in the neighborhood of the Arcola (N. J.) Country Club April 11, when Edward D. Easton, president of the Columbia Graphophone Co., and a large party of the directors, officials and employes foregathered to celebrate the twenty-fifth anniversary of the founding of the company. Most of the guests made the club early in the afternoon, for the weather was perfect and the club kept open house, indoors and out. The golf course claimed a good many and some remarkable scores were made.

It was one of the occasions—they do happen every once in a while—when the Columbia organization lifted the lid and cut loose, and the invited guests were permitted to see something of the good fellowship, co-operation and mutual loyalty that exists in the organization—the spirit which, in short, has been the dominant factor in building it up. It is a thing about which not much has been said, but it is there. It is a constant and wholehearted reinforcement one of another by everyone, from the president down to the executive office door boy.

It is that spirit which has created and recreated the Columbia Graphophone Co.—and it started from the top. President E. D. Easton's personality, never blatant, tremendously magnetic, together with his genius for the selection and inspiration of his forces, has been one of the biggest things that the talking machine trade has known since its very inception. And Saturday night's foregathering early resolved itself into a large and enthusiastic utterance of tributes to the man.

At the dinner in the evening covers were laid for fifty. President E. D. Easton himself was in the chair, and those present were as follows: George W. Lyle, vice-president and general manager; E. N. Burns, vice-president and manager of the export department; Senator William M. Johnson, director; Dr. David St. John, director; F. J. Warburton, director; C. W. Cox, director; C. A. L. Massie, director and patent counsel; H. L. Willson, assistant general manager; Mervin E. Lyle, factory manager; H. A. Budlong, assistant factory manager; C. E. Woods, supervising engineer; Horace Sheble, efficiency engineer; E. K. Camp, counsel; Ralph L. Scott, patent counsel; Marion Dorian, auditor and treasurer; T. Allan Laurie, assistant auditor; G. L. Funnell, London factory manager; J. I. Brereton, purchasing agent; G. C. Jell, chairman record committee; V. H. Emerson, manager record department; C. W. Woddrop, secretary and assistant treasurer; T. E. Novakoski, assistant treasurer; A. E. Garmaize, export department; Louis Sterling, European sales manager; A. G. Farquharson, Canadian manager; Otis C. Dorian, assistant Canadian manager; E. B. Jordan, Jr., guest; W. S. Scherman, advertising department; F. L. Capps, experimental department; F. E. Goodwin, education department; H. B. Ray, advertising manager; M. D. Easton, dictaphone advertising manager; G. P. Metzger, advertising counsel; H. A. Yerkes, wholesale department manager; Frank Dorian, dictaphone manager; J. D. Westervelt, manager of dictaphone agencies; John Button, assistant dictaphone manager; N. F. Milnor, New York dictaphone sales manager; Thomas F. Murray, guest; Homer W. Reid, chief accountant, Bridgeport, Conn.; Hayward Cleveland, manager Thirty-third street store; H. C. Grove, manager Washington store; R. F. Bolton, New York wholesale manager; Anton Heindl, manager of foreign record department; J. C. Ray, assistant to Mr. Willson; Harold Lyle, foreign record department; Walton Mayer, Pittsburgh, guest; E. E. Robinson, representative of the export department in the Orient; Henry E. Parker, advertising department.

There was no set program of speeches, but a whole lot of interesting talk followed the dinner.

President E. D. Easton, arising amid cheering, said:

"Gentlemen, the Columbia Phonograph Co. was

born on January 15, 1889, so that it was twenty-five years old nearly three months ago. But we were not quite ready then to celebrate, therefore it was postponed until to-night in order that more of us could meet together. I want to express to you all my very great affection and regard and appreciation of your services. We have no program for this evening, but I will exercise the privilege of calling upon many of those who, are present for impromptu speeches. I only want to say that I am very happy indeed to be here with you and to see all these splendid men, and hope that you may carry away pleasant memories of the evening. I think the first speaker should be the



Edward D. Easton, President.

man who has, next to myself, been longest in the service of the company—Frank Dorian—who has had the full twenty-five years' service with us."

Frank Dorian Heard From.

Frank Dorian, general manager of the dictaphone, spoke briefly—so briefly, in fact, that someone suggested that he felt embarrassed because there was no dictaphone to dictate to. He said: "I can only echo the words of our president. It is indeed a great pleasure to be here and with the company, and a great privilege to have been associated with Mr. Easton. I may not hope for another twenty-five years, but I do not feel that my education is yet completed, and I hope to be associated with him for many years to come."

H. A. Budlong, assistant factory manager, who was called upon, expressed his pleasure at being present.

Men Who Have Distinguished Themselves.

E. D. Easton arose at this juncture and said that he had been struck with the presence of so many of his previous secretaries—Mervin E. Lyle, Otis C. Dorian, M. D. Easton, Frank Dorian, J. C. Button, H. L. Willson and H. A. Budlong. Said he: "My secretaries have many of them distinguished themselves since. Frank Dorian was for many years our European general manager. Mervin Lyle has just taken one of our biggest posts as manager of the factory in Bridgeport. Otis Dorian is now assistant manager in Canada. Mr. Willson is now serving as assistant general manager of the company. Mr. Budlong has long had charge of very responsible work in the factory, of which he is the assistant manager, and J. C. Button and M. D. Easton are doing important work in the executive office."

Elisha K. Camp's Remarks.

Elisha K. Camp, of the legal department, said: "It does seem to me on an occasion of this sort, when brief speeches are the order, that I am the most inappropriate person to be called on. Because if any one man, more than another, should be expected to be able to speak a lot it would be the attorney for a talking machine company. Of

the many cackling chicks hatched by the North American Phonograph Co., the Columbia was the only one that was able to last for any length of time. Mr. Easton, as you all know, was the man who got the exclusive rights from the North American Phonograph Co. for Delaware, Maryland and the District of Columbia, which he transferred to the Columbia Phonograph Co., and he was very careful at the time—with his usual foresight—to have read into his contract the express covenant of the grantor that it would not come into the ceded territory. I think that, of all those sub-licensees, the Columbia Phonograph Co. was the only one with that express covenant, and that was due to Mr. Easton's foresight. While the celebration to-night is in itself a great event, I think we have even greater cause for celebration in that we have preserved to us the man who originally made the Columbia Phonograph Co. and who has brought it along up to the present time to what it is now. You all remember what a serious illness he recently passed through and how successfully he has recovered, even as we had all prayed that he would come through as well as he has. And while we are celebrating to-night we should be very thankful to think that he is with us in such splendid health and spirits, ready to be with us for another twenty-five years or even more (applause). I do not know of any man who has the ability to infuse the same enthusiasm into his colleagues as Mr. Easton. I do not know of a body of men who have responded more loyally to their chief than the men who are here and the men who have served the company of which he has been such a distinguished head." (Cheers.)

Some Other Speakers.

Marion Dorian, auditor, next made a few brief remarks, and was followed by Louis Sterling, European general sales manager, who declared that he had "been having such a very good time that he didn't want to interrupt it by saying anything. His only cause for regret was that he had never served as a secretary to Mr. Easton (laughter). It was a pleasure and an inspiration to come across to this side of the water every once in a while and to realize the magnitude of the business with which he was connected. During the four and a half years during which he had been with the Columbia they had carried the Columbia flag throughout Europe and they had succeeded in showing Europe that American ideas could be worth a very great deal indeed."

George P. Metzger, advertising counsel, made a humorous speech, mainly about golf, and was followed by Mervin Lyle, manager of the Bridgeport factory, who said that although his actual service with the company only covered a period of twelve years, he had really been associated in a commercial way a long while before that, as far as 1892, when it had a store in Baltimore.

Big Improvements Coming Say Woods.

C. E. Woods, supervisor of engineering, arising amid cheers, said that he felt pretty young in the business. "It seems to me," he continued, "that I have never seen a more glorious opportunity for the development of the business. Our future is full of possibilities, and it does seem that we can't get to them quick enough. There is almost virgin field in many directions. We are making the talking machine to-day as we have made it for many years, but yet I think there are big improvements coming. I am looking forward to the time when we can bring the talking machine up to a point where it will be regarded just as much a household necessity as the piano, and more so. It is only a matter of education." Mr. Woods spoke at further length on the eminent prospects of extensive improvements in the science of sound reproduction.

Horace Sheble's "Experiences."

Horace Sheble, formerly factory manager and at present efficiency engineer, said his experiences with the company dated back over twenty years, and said over twenty years ago he had been a salesman selling to the company. He had sold them their first typewriter. Mr. Easton had reciprocated by selling him one of the first graphophones. And then he himself got even by supplying the company with sapphire points at ten cents apiece.

C. A. L. Massie was another one to express his



"Cohen on the Telephone," the most humorous record issued since the famous Weber & Fields series. A 65c. Columbia Double Disc Record.



(Write for "Music Money," a book "full of meat" for those dealers interested in quick and frequent turnover of capital.)

**Columbia Graphophone Company
Woolworth Building, New York**

COLUMBIA GRAPHOPHONE CO.'S 25th ANNIVERSARY.

(Continued from page 58.)

high satisfaction at being present in very brief terms.

V. H. Emerson, the company's recording superintendent, was next on the list, and gave flashes of championship form as a monologist.

Messrs. Farquharson and Willson were others who spoke with excessive brevity, and J. C. Button made a hit with a humorous and appropriate story.

Why Prof. Goodwin Is an Optimist.

Prof. Frederic Goodwin, head of the educational department, said his personal association with the company did not go very far back into its history. He only knew of its past record and its present

guard that I feel for you." Speaking from his own present individual experience, although his crew of men might look very small in comparison with the company's forces, at the same time one of the biggest pleasures that he had to-day came from the fact that he had a selling organization in New York of every man of which he was mighty proud. They had neither a "boozier" nor a "borrower" in the whole force. There wasn't a man who had ever attempted to misrepresent the product he had to sell and their drawing accounts were never overdrawn. He had never seen an organization that pulled together as did their own.



Snap Shot Taken at Banquet of Columbia Forces at Twenty-fifth Anniversary Dinner.

prosperity. The history of the graphophone was the history of most inventions: First, a matter of smiles, then a subject of amusement, and then it came into its own field of real usefulness. He himself was an optimist, and from what he had already seen of the advances they had made in conjunction with national education, he anticipated a tremendous development in the future.

Messrs. E. B. Jordan, Jr., and T. F. Murray followed, the latter making the briefest speech of the evening. Anton Heindl, New York manager of foreign recording, then drew on a fund of personal reminiscences of past happenings and anticipated the future with a magnificent optimism.

A Strong Body of Men.

N. F. Milnor, Dictaphone sales manager, of New York, said that as he looked back at his own past experience in sales organizations in many cities he had never in his life met a force of men whose acquaintance had been worth more than those who were in the service of the Columbia Graphophone Co. To Mr. Easton was the credit due for having assembled and inspired as clean a body of men as any organization ever had. Mr. Easton in his remarks that evening had used one phrase that had appealed to him very strongly, a phrase which it seemed to him served to indicate the foundation of the Columbia spirit. He had said, "I want you to know the affection and re-

mercial corporation. This one is remarkable in that the head of the organization who first founded it is still the honored head of the company to-day. I have often wondered how it was and where it was that you got together such a magnificent force of enthusiastic, brainy, earnest, industrious and successful men. I suppose it is because you catch them young—like Mervin Lyle. Of course, you naturally get good results, but that could not have been achieved if it had not been for the enthusiasm and the untiring example that Mr. Easton has demonstrated to the forces of this company for all these years. I never knew a man possessed of a greater degree of enthusiasm and confidence nor one who has a greater faculty than he has for inspiring that spirit in others. That is a very big part of the success this organization has achieved. Mr. Easton selected the right men and then inspired them with his own enthusiasm.

"This company's success is traceable in a large degree to the unusual character of that one man. This argues well for the future of the company. It has taken a good many years to build up this body of men. And the result is that the Columbia Graphophone Co. to-day has more than its mere financial and physical existence. Imagine for a minute what would happen were this magnificent force to be disbanded! How many years would it take to build up an organization equal to this? You and I know that it would be the task of years. Therefore we are proud to know that this period of twenty-five years has resulted in establishing an organization which now we regard as in its prime, in its full maturity, and prepared to go forward to greater victories even than it has accomplished in the past. I want to propose the health of our honored president, E. D. Easton.

The toast was drunk standing and with cheers.

Mr. Easton briefly acknowledged the toast and again thanked the men for their devotion and services. After a short speech by Dr. St. John, who said he would sooner remove an appendix than make a speech any day, the gathering adjourned.

PEASE PIANO CO. EXPANSION

To Cope with Growing Business—P. Decker Again in Charge of the Department.

The Pease Piano Co., 128 West Forty-second street, New York, has enlarged its talking machine department to take care of its fast growing trade. P. Decker has again taken charge of this department after spending some time with the Berliner Gramophone Co., Montreal. Mr. Decker opened the Pease talking machine department two and a half years ago, and is therefore well acquainted with the Pease clientele. A complete stock of Victor and Columbia products is handled in this department.

CHEMISCHE FABRIK E. SAUERLANDT FLURSTEDT
 The largest manufacturing plant in the world devoted exclusively to the
 manufacture of Master-Waxes and Master-Blanks for
Gramophone and Phonograph Recording
 Sole Manufacturer of Wax "P." the best recording material for Berliner-cut.

LATEST PATENTS RELATING TO TALKING MACHINES AND RECORDS

(Special to The Talking Machine World.)

WASHINGTON, D. C., May 6.—PHONOGRAPH—Newman H. Holland, assignor to the New Jersey Patent Co., of West Orange, N. J. Patent No. 1,092,911.

This invention relates to phonographs and more particularly to new and improved means whereby the record of a phonograph may be readily disengaged from its support without damage to the record surface.

As ordinary phonograph records change in diameter to a considerable extent under different temperature conditions expanding under heat and contracting under cold, and as the supports upon which the records are mounted change but little in diameter under the same conditions and are so constructed that when the records are slipped thereon, a tight engagement will be maintained between the same and the records, it frequently happens that the latter become so tightly locked to their supports that it is practically impossible to remove them by hand without damage to them.

It is the principal object of this invention to overcome this difficulty by providing improved means for automatically loosening the record from its support so as to permit it to be readily removed by hand. In conformity with this object,

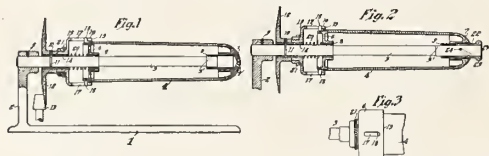

a movable record support is preferably provided and means mounted in proximity thereto for shifting the record relatively to the said support when the mandrel is moved from its normal position.

Other objects of the invention consist in the construction of parts and combinations of elements as will be more particularly pointed out in the claims.

Figure 1 represents a vertical longitudinal section through the center of the mandrel of a phonograph embodying my invention; Fig. 2 represents a similar view of a modification; and Fig. 3 represents a plan view of the left hand end of the mandrel.

SOUND BOX.—William W. Zackey, Philadelphia, Pa. Patent No. 1,092,552.

This invention relates to sound boxes for sound recording and reproducing machines, and has for an object to provide a diaphragm and mounting therefor, whereby not only is the sound reproduced in a desirable volume, but it is also perfect in quality and tone being free from metallic, grinding or scratching sounds.

It has for a further object to provide a sound box in which a portion of the diaphragm substantially floats within the box, and operates in conjunction with a flexible member formed of a

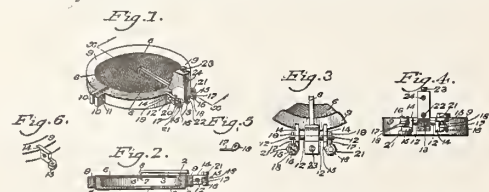

suitable fabric whereby a sensitive and delicate means of transmitting sound waves is provided.

It has for a further object to provide a novel mounting for the stylus bar which operates in conjunction with the novel diaphragm construction to produce a balanced condition which materially increases the effective action of the diaphragm in the reproduction of sounds.

Figure 1 represents a perspective of a sound box embodying my invention. Fig. 2 represents a section on line x-x of Fig. 1. Fig. 3 represents a plan of a portion of the sound box showing details of the stylus bar mounting. Fig. 4 repre-

sents a side elevation of the part shown in Fig. 3. Fig. 5 represents a perspective of one of the diaphragm springs. Fig. 6 represents a perspective of one of the stylus bar supporting ears.

RECORD-HOLDER.—Julius Roeber, New York City. Patent No. 1,094,476.

This invention relates to improvements in record holders for phonograph records and especially to that class of holders which are mounted on a wheel or other rotary device, so that the records can be brought into successive operation. In record holders of this kind it has been found difficult to get a structure which would permit of a record being easily slipped on or off the holder, and at the same time permit of the record being easily adjusted so that the needle of the reproducer will strike exactly in the right point of the record.

The object of the invention is to produce a record holder which will permit a record to be instantly slipped on endwise over the holder without the necessity of operating or adjusting any mechanism, and in which the record can then be accurately adjusted in relation to the stylus of the reproducer.

A further object of the invention is to produce a holder which is cheap to manufacture and simple in construction, and one in which the friction of rotation is reduced to a minimum.

Other objects of the invention are to produce a record holder upon which a record can be easily placed or removed, and on which the ends of the record are left entirely free so that there is no danger of breaking them, and nothing to interfere with their adjustment, and further to produce a record holder which can not only be adjusted in and out on its supports, but has a central driving

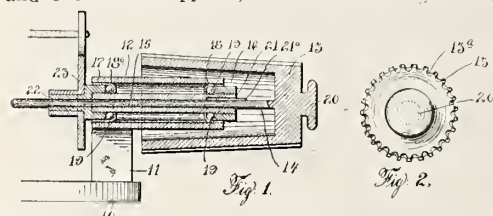

spindle extending through the support, and which can be entirely removed when necessary.

Another important feature of the invention is this: Phonograph records are of two general kinds, known in the trade as "wax records" and "indestructible records." The indestructible records can be carried on a skeleton holder, but the wax records cannot, because they are likely to collapse. Moreover, on record holders having a solid face, the wax records in either very warm or very cold weather are likely to stick so that they break in taking them off. I provide my record holder, however, with longitudinal corrugations so that it presents a good gripping surface to the inner wall of the cylinder, but will not stick closely to the wax record, and so such records can be easily placed on or taken off the record holder, while the holder is also as well adapted to securing a so-called indestructible record.

Figure 1 is a longitudinal section of a record holder embodying my invention, and Fig. 2 is an end view of the holder proper.

TONE-ARM FOR TALKING MACHINES.—Edmund Peltovitz, East Orange, N. J. Patent No. 1,094,166.

This invention has reference, generally, to improvements in tone arms for talking machines; and, the invention relates, more particularly, to a novel form of accordion-plaited stem for use with machines of the character above stated and with the amplifying horns employed with such machine, with a view of providing a means which will permit the sound box to be readily raised from its reproducing contact with the record cylinder of the phonograph, or from the record-disc of the gramophone or talking machine, without in the least affecting the relatively fixed position of

the amplifying horn; and, also to provide a tone-arm which will swing laterally as the sound box moves along the cylinder or from the central portion of the disc to the outer circumferential edge of the latter.

The invention has for its further object to provide a simple and effectively operating means which will modify the sound and will overcome absolutely the metallic or squeaky sounds caused by the usual amplifying horns.

The said invention consists, primarily, in the novel accordion-plaited tone-arm for phonographs and talking machines of the various constructions, and the amplifying horns therefor, hereinafter set forth; and, the said invention consists, furthermore, in the general arrangements and combinations of the various devices and parts, as well as in the details of the construction of the same, all of which will be more fully embodied in the clauses of the claim which are appended to and which form an essential part of this specification.

Figure 1 is a side elevation of one form of

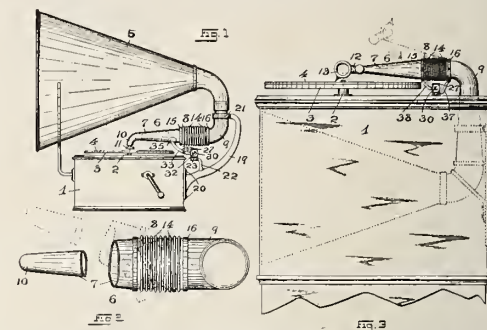

talking machine and amplifying horn, with an accordion-plaited tone-arm made according to and embodying the principles of the present invention, said view illustrating also in connection with the said devices, one means for securing the tone-arm in its operative position with relation to the record-disc of the machine and to the amplifying horn. Fig. 2 is an enlarged top view of portions of the said accordion-plaited tone-arm, said view illustrating, also, the oscillatory relation of the parts of the said arm to each other. Fig. 3 is a view similar to that represented in said Fig. 1, showing the application of the accordion-plaited tone-arm to that style of talking machine or gramophone in which the amplifying horn is contained in the case or box of the talking machine.

Fig. 4 is an enlarged longitudinal vertical section of the accordion-plaited or bellows-portion of the tone-arm; Fig. 5 is a horizontal section of one form of supporting bracket for the tone-arm, said section being taken on line 5-5 in said Fig. 4, looking in the direction of the arrow x, and the parts of the supporting bracket being shown in their normal initial positions. Fig. 6 is a view

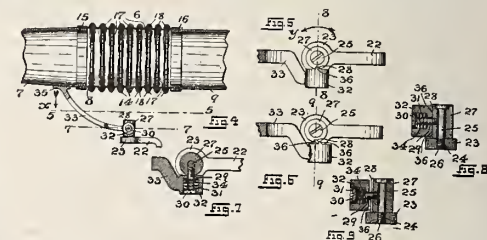

similar to that represented in said Fig. 5, the parts of the supporting-bracket being represented in their operated positions when one of the arm-sections, with which the sound box is connected, is slightly raised so as to elevate the sound box above the surface of and out of contact with the record-disc or cylinder. Fig. 7 is a horizontal section taken on line 7-7 in said Fig. 4; Fig. 8 is a transverse vertical section, taken on line 8-8 in Fig. 5; and Fig. 9 is a similar section, taken on line 9-9 in Fig. 6, all of said views being made upon a much larger scale.

TALKING MACHINE.—Joshua Green, of London, Eng. Patent No. 1,094,067.

This invention relates to improvements in talking machines and has mainly for its object to provide a machine which, while possessing a horn of full, or approximately full dimensions, yet when not required for use can be packed into a small space, thus rendering the machine eminent-

LATEST PATENTS RELATING TO TALKING MACHINES—(Continued from page 60).

ly suitable for many purposes, for example, for transport from place to place.

According to the invention the talking machine is constructed with a horn made in a number, preferably two, of parts, one of which is fixed within the casing of the machine and the other or others is or are adapted to telescope relatively thereto, so that when not required for use the said part or parts can be pushed partially or wholly within the fixed portion, but when required for use can be drawn out and turned into position to receive the tone-arm.

The invention can be advantageously employed in combination with the known type of machine in which the horn is placed below the motor and in which the case of the machine is of cylindrical construction. With such a machine I combine a horn consisting of a fixed or stationary portion arranged within the said cylinder so that its larger or flared end is flush with one end thereof, and of a second movable elbow shaped portion which can telescope into the fixed part. This movable part, which slides within the fixed portion, is preferably also of a taper shape so that when the complete horn is extended, it is of the normal, or approximately the normal contour. The meeting ends of the two parts of the horn are preferably screw-threaded, or provided with any other suitable device, by means of which they can be locked in position when the movable elbow part is drawn out and turned to bring it into the proper position for receiving the tone-arm, which, in the form of gramophone under consideration, is at the top of the cylinder body. The end of the casing which receives the moving elbow part of the horn is closed with a cover, which, however, is provided with a slotted portion at its lower part to

with during recording. It is also desirable that the recorder-reproducer be capable of lateral as well as vertical play when reproducing, but he locked absolutely against lateral play during recording; and in said patent this is accomplished by means of the engagement of the forward portion or nose of said weight within a fixed support. However, in the practical operation of the device of said prior Macdonald patent, it has been found that during the operation of recording, the suspended weight is so connected to the stem or neck of the recorder-reproducer as to exert upon the latter a drag, which although slight, is sometimes appreciable in preventing perfect accuracy of operation; and it has also been found that, owing perhaps to lack of utmost precision in wholesale manufacturing operations, the unintended looseness of the parts sometimes permits a slight lateral play of the diaphragm-head during recording.

According to the present invention, the vertically-swinging weight, though mounted upon the diaphragm-head or recorder-reproducer, is pivoted

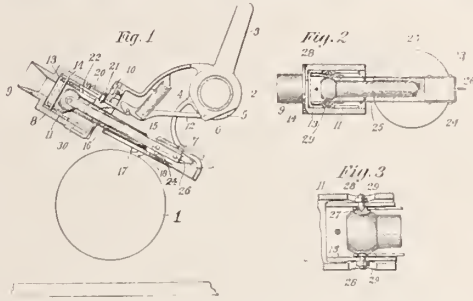

thereon concentrically of the horizontal pivot or axis of the latter, so that the weight and the recorder-reproducer, in swinging vertically, swing independently of each other and without interference from each other.

One feature of the invention, then, consists of the novel arrangement and mounting of the weight.

Another feature of the invention consists of improved means for securing the recorder-reproducer against lateral play when recording. And the invention consists further in the various features of construction and arrangement hereinafter pointed out and claimed.

Figure 1 is an end view, partly in transverse section, of a dictation graphophone equipped with a preferred embodiment of the present invention; Fig. 2 is a longitudinal section through the novel mounting of the speaker and of the weight; and Fig. 3 is a similar view on an enlarged scale.

SOUND BOX AND MOUNTING THEREFOR.—Thomas H. Macdonald, assignor to the American Graphophone Co., Bridgeport, Conn. Patent No. 1,093,710.

This invention relates to talking machines, particularly the type for carrying a disc record with lateral undulations and comprises an improved construction of sound-box and an improved manner of mounting it, preferably upon the well-known horizontally-swinging hollow arm that connects with the flaring horn.

The invention consists further in certain details that will be pointed out and claimed.

In the drawings, Figure 1 is a side elevation of the sound-box and arm attached to a machine.

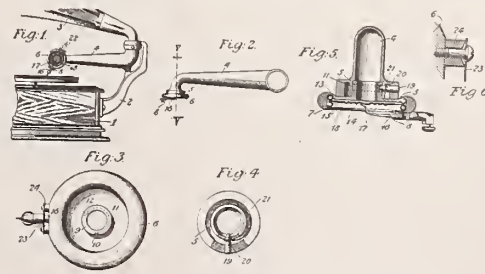

Fig. 2 is a top view of the sound-box and the arm on which it is mounted. Figs. 3 and 4 are details on a larger scale showing respectively the adjacent faces of the sound-box and of the end of the arm. Fig. 5 is a transverse section, through the line V-V of Fig. 2. Fig. 6 is a detail show-

ing the manner of securing the stylus-bar to the sound-box.

TALKING MACHINE.—Eugene A. Friedlander, of Cleveland, O. Patent No. 1,093,611.

The present invention relates in general to talking machines, and is intended particularly to provide protection for the delicate mechanism employed in such machines.

The general object of the invention, therefore, is to provide a protective inclosure for talking machines which will still allow the swinging move-

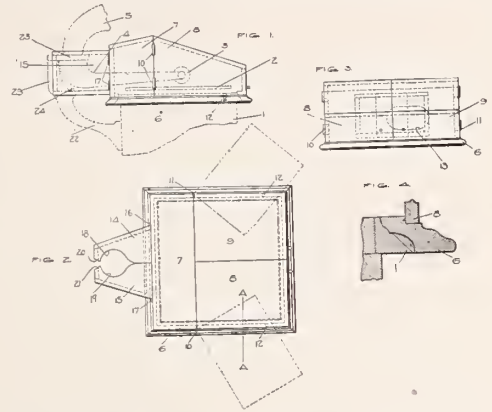

ment of the tone-arm, and which will also allow easy access to the reproducing mechanism.

In said annexed drawings:—Figure 1 is a side elevation of a machine embodying my invention, certain parts being diagrammatically shown; Fig. 2 is a top plan, certain parts being diagrammatically shown in alternative positions; Fig. 3 is a front elevation, and Fig. 4 is a section on the line A A of Fig. 2.

CONTAINS INTERESTING FEATURES.

The Victor Co.'s Semi-Annual Catalog, Complete to Date, Just Issued—Publication Devoted to Dance Records Exclusively.

The Victor Co. sent out recently its regular semi-annual complete catalog of all Victor records issued to date. Arranged and compiled in the usual thorough and high-grade Victor style, this catalog embodies certain additions and improvements which should considerably enhance its value. Accompanying this record catalog was an attractive publication listing Victor dance records exclusively. Mr. and Mrs. Vernon Castle, the popular interpreters of the modern dances, are shown dancing all the latest dances, while an original feature of this publication is the listing of the number of measures or bars to each minute, after the name of each selection. Customers can thus select records played at any speed desired.

T. A. EDISON HOME FROM FLORIDA.

Thomas A. Edison returned to his home April 20 after an outing to Florida which he enjoyed very much and which benefited him considerably. On his trip South Mr. Edison was accompanied by a number of prominent captains of industry, including Henry Ford, the well-known automobile manufacturer.

60 YEARS' EXPERIENCE

PATENTS

TRADE MARKS
DESIGNS
COPYRIGHTS & C.

Anyone sending a sketch and description may quickly ascertain our opinion free whether an invention is probably patentable. Communications strictly confidential. HANDBOOK on Patents sent free. Oldest agency for securing patents. Patents taken through Munn & Co. receive special notice, without charge, in the

Scientific American.

A handsomely illustrated weekly. Largest circulation of any scientific journal. Terms, \$3 a year; four months, \$1. Sold by all newsdealers.

MUNN & Co. 361 Broadway, New York
Branch Office, 625 F St., Washington, D. C.

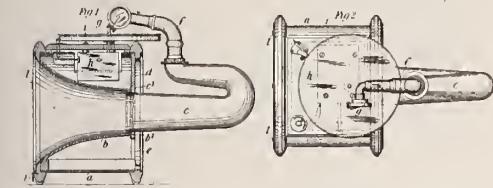

receive the extremity of the horn when the latter is turned down and telescoped into the fixed horn part. It will thus be seen that when the machine is dismantled it occupies a space which practically corresponds with that of the casing. Furthermore, means may advantageously be provided in conjunction with the flared end of the horn whereby the said end may be adapted to receive a carrier or holder for records or the usual turntable when the machine is not required for use. The holder or turn-table thus constitutes a cover to the open end of the horn which may serve as a receptacle for the tone-arm.

In the accompanying drawings—Figure 1 is a sectional side view of one form of gramophone machine made according to the invention. Fig. 2 is a plan view thereof. Fig. 3 is a view similar to Fig. 1 but showing the horn in the collapsed position, and Fig. 4 is an end view showing the parts in the position illustrated in Fig. 3.

COMBINED RECORDER AND REPRODUCER.—John J. Scully, assignor to the American Graphophone Co., Bridgeport, Conn. Patent No. 1,093,732.

This invention relates to talking machines whose "speaker" or "diaphragm-head," sometimes referred to as the "recorder-reproducer," is provided with two styli upon the one diaphragm, and is adapted to be shifted longitudinally for use interchangeably as a recorder or as a reproducer.

More particularly, the present invention may be regarded as an improvement upon the structure set forth in the prior Macdonald Patent No. 1,003,625, granted September 19, 1911. In instruments of this character it is desirable that the recorder-reproducer be comparatively light when recording, but comparatively heavy when reproducing; and in said Patent No. 1,003,625, this is accomplished by means of a vertically-movable weight pivoted upon the neck of the diaphragm-head in such manner that it will bear its full weight upon the upper face of said head during the operation of reproducing, but will be held out of contact there-

RECORD BULLETINS FOR JUNE, 1914

THOMAS A. EDISON, INC.

- EIGHT SPECIAL DANCE RECORDS.
- 2291 Dengozo—Maxixe—Tango Brazilian (Ernesto Nazareth).....National Promenade Band
 - 2292 Maurice—Hesitation Waltz (Jas. M. Shaw).....National Promenade Band
 - 2293 Isle D'Amour—Waltz Hesitation (Leo Edwards).....National Promenade Band
 - 2294 Leg of Mutton—One-step (S. Romberg).....National Promenade Band
 - 2295 The Queen of the Movies Medley—Turkey Trot (Jean Gilbert).....National Promenade Band
 - 2296 Rye Waltzes—Scotch Melodies.....National Promenade Band
 - 2297 Some Smoke—One-step (S. Romberg).....National Promenade Band
 - 2298 The Poem—Waltz Boston (S. Romberg).....National Promenade Band
- REGULAR AMBEROLA LIST.
- 2299 Favorite Airs from "The Prince of Pilsen" (Gustav Luders).....Edison Light Opera Company
 - 2300 In the Valley of the Moon (Jeff Brannen). Soprano and Baritone Solo, orch. accomp.....Elizabeth Spencer and Vernon Archibald
 - 2301 Flower Song (G. Lange). Violin, Violoncello, Flute and Harp.....Venetian Instrumental Quartet
 - 2302 When the Maple Leaves were Falling (Tell Taylor). Contralto and Tenor, orch. accomp.....Helen Clark and Emory B. Randolph
 - 2303 Why is the Ocean so Near the Shore?—When Claudia Smiles (Clarence Jones). Comic Song, orch. accomp.....Ada Jones
 - 2304 In the Town Where I was Born (Al Harriman). Baritone and Chorus, orch. accomp.....Owen J. McCormack and Chorus
 - 2305 While the Rivers of Love Flow On (Ernest R. Ball). Tenor Solo, orch. accomp.....Charles W. Harrison
 - 2306 St. John 14:1-3, and A Home on High (Geo. C. Stebbins). Scripture Lesson with Hymn, organ accomp.....Rev. Madison C. Peters, DD, and Edison Mixed Quartet
 - 2307 Sweet Thoughts of Home (Julian Edwards). Contralto Solo, orch. accomp.....Mary Jordan
 - 2308 Going Back to Arkansas. Vaudeville Sketch.....Golden and Hughes
 - 2309 Lord, I'm Coming Home (Wm. J. Kirkpatrick). Sacred Solo, orch. accomp.....John Young and Frederick J. Wheeler
 - 2310 She's Dancing Her Heart Away (Kerry Mills). Tenor Solo, orch. accomp.....Manuel Romain
 - 2311 Where Can I Meet You To-night? (Arthur Lange). Conversational Duet, orch. accomp.....Ada Jones and Billy Murray
 - 2312 I Love You Just Like Lincoln Loved the Old Red, White and Blue (Jean Schwartz). Male voices and orch. accomp.....Peerless Quartet
 - 2313 At the Mermaids' Fancy Ball (Harry Israel). Comic Song, orch. accomp.....Billy Murray
 - 2314 Celebratin' Day in Tennessee (Jack Glogau). Coon Duet, orch. accomp.....Arthur Collins and Byron G. Harlan
 - 2315 In the Valley Where the Blue-Birds Sing (Alfred Solman). Tenor and Chorus, orch. accomp.....Emory B. Randolph and Chorus
 - 2316 Mother's Dear Old Chair (Genevieve Scott). Contralto and Tenor, orch. accomp.....Helen Clark and Harvey Hindemeyer
- B. P. O. E. RECORDS.
- 2317 Elks' Opening and Closing Odes.....Knickerbocker Quartet
 - 2318 Elks' Initory March and "Nearer My God to Thee".....Organ and Knickerbocker Quartet
 - 2319 Elks' Funeral Odes.....Knickerbocker Quartet
 - 2320 B. P. O. E.—Elks' Song.....Nat M. Wills
 - 2321 Elks' Minstrels.....Nat M. Wills
- LOYAL MOOSE RECORDS.
- 2322 Loyal Order of Moose Opening and Memorial Odes.....Male Quartet
 - 2323 Loyal Order of Moose Initory Odes.....Male Quartet
 - 2324 Loyal Order of Moose Closing Ode.....Male Quartet
- SPECIAL FOR CANADA.
- 2290 Medley of French-Canadian Airs (J. Vézina).....Edison Concert Band

COLUMBIA GRAPOPHONE CO.

- SYMPHONY SINGLE-DISC RECORDS.
- | | | |
|-------|---|-------|
| No. | | Size. |
| 36860 | The Low Back'd Car (Lover) Soprano Solo in English with orch. accomp.....Margaret Woodrow Wilson | 12 |
| 39267 | Leezie Lindsay (Old Scotch Melody). Soprano Solo in English with orch. accomp.....Margaret Woodrow Wilson | 10 |
| 39195 | My Laddie (Thayer). Soprano Solo in English with orch. accomp.....Margaret Woodrow Wilson | 10 |
- SYMPHONY DISC RECORDS.
- By Bernice de Pasquali 12 inch records.
- | | | |
|---------|---|--------|
| Double. | | Single |
| A5554 | Lo, Here the Gentle Lark (Bishop). Soprano Solo in English with orch. accomp.....Henri Scott | 36826 |
| | Carmen (Bizet) Michaela's Aria—"I Say to the Dread that Assails Me." Soprano Solo in English, with orch. accomp.....Henri Scott | 36911 |
| A5552 | Magic Flute (Mozart). "In diesen heil'gen Hallen" (Within this sacred dwelling). Bass Solo in German, with orch. accomp.....Henri Scott | 12 |
| | Ernani (Verdi). "Infelice e tuo credevi" (Unhappy one, that I so trusted). Bass Solo in Italian, with orch. accomp.....Henri Scott | 12 |
| A5550 | Gnomemreigen (Liszt). Pianoforte Solo.....Leopold Godowsky | 12 |
| | Polonaise in A Flat (Chopin). Pianoforte Solo.....Leopold Godowsky | 12 |
| A5551 | Nada (Mott). Tenor Solo, orch. accomp.....Morgan Kingston | 12 |
| | My Message (D'Hardelot) Tenor Solo, orch. accomp.....Morgan Kingston | 12 |
- BLUE-LABEL DOUBLE-DISC RECORD.
- A1518 Zigeunerweisen (Gypsy Air) (Sarasate). Violin Solo.....Jules Falk
 - Madrigale (Simonetti). Violin Solo.....Jules Falk
- DOUBLE-DISC RECORDS.
- A1516 Cohen on the Telephone. Humorous sketch.....Joe Hayman
 - Happy Tho' Married. Humorous sketch.....Fred Duprez
 - A1517 Music Store Echoes (Smith).....Prince's Orchestra
 - The Ghost's Cabaret (Smith).....Prince's Orchestra
 - A1522 Mona (Adams). Tenor Solo, orch. accomp.....Harry McClaskey
 - Resignation (Caro Roma). Counter-Tenor Solo, orch. accomp.....Frank Coombs

- A1519 The Gypsy (Wottitz).....Berkes-Bela Gypsy Orchestra
 - Spoontime (H. Von Tilzer).....Berkes-Bela Gypsy Orchestra
 - A5553 Three Fishers Went Sailing (Hullan). Contralto Solo, orch. accomp.....Carrie Herwin
 - Husheen (Needham). Contralto Solo, orch. accomp.....Carrie Herwin
- DANCE RECORDS UNDER SUPERVISION OF G. HEPBURN WILSON.
- A5549 Dengozo (Nazareth). Maxixe.....Prince's Band
 - All for the Girlies (Gilbert). One-Step.....Prince's Band
 - A5556 You're Here and I'm Here (Kern). One-step.....Prince's Band
 - Kissing Cup (Platzman). Waltz-Hesitation.....Prince's Band
 - A5557 Camp Meeting Band (Gilbert and Muir). One-step.....Prince's Band
 - You Can't Get Away From It (Schwartz). One-step.....Prince's Band
 - A5555 Fascination (Smith). One-step.....Prince's Band
 - You and I (Langey). Waltz-Hesitation.....Prince's Band
- POPULAR SUCCESSES FOR JUNE.
- A1523 Everybody Loves My Girl (Ayer). Orch. accomp.....Peerless Quartet
 - If I Had Someone at Home Like You (Mona). Soprano Solo, orch. accomp.....Elida Morris
 - A1521 In the Heart of the City That Has No Heart (Daly). Tenor Solo, orch. accomp.....Henry Burr
 - Why Don't You Tell Me You Love Me, When You Know You Do? (Reed). Tenor Duet, orch. accomp.....A. Campbell and H. Burr
 - A1524 Do You Remember (Carroll). Tenor Solo, orch. accomp.....Chas. W. Harrison
 - That's a Real Moving Picture from Life (H. Von Tilzer). Counter-Tenor Solo, orch. accomp.....Manuel Romain
 - A1525 Celebrating Day in Tennessee (Glogau). Baritone and Tenor Duet, orch. accomp.....Arthur Collins and Byron G. Harlan
 - He's a Devil in His Own Home Town (Berlin). Baritone Solo, orch. accomp.....Ed. Morton
 - A1526 Smother Me with Kisses (Carroll). Soprano and Tenor Duet, orch. accomp.....Ada Jones and Billy Watkins
 - Hands Off (H. Von Tilzer). Tenor Solo, orch. accomp.....Billy Watkins

VICTOR TALKING MACHINE CO.

- | | | |
|-------|---|-------|
| No. | | Size. |
| 17559 | Ha-Za-Za, from "Sari" including "Pick a Husband"—One-step. (Kálmán).....Victor Military Band | 10 |
| | A Zut Alors (As You Please)—One-step (L. La Mont).....Victor Military Band | 10 |
| 35380 | While They Were Dancing Around Medley—One-step.....Victor Military Band | 12 |
| | Crazy Bone Rag—One-step (C. L. Johnson).....United States Marine Band | 12 |
| 17575 | Too Much Ginger—One step (Jos. M. Daly) (Banjo, piano and drums).....Vap Eps Trio | 10 |
| | The Smiler Rag Medley—One-step (Percy Wenrich).....Van Eps Trio | 10 |
| 17540 | In that Blue Ridge Vale of Love (Mohr).....Edna Brown-James F. Harrison | 10 |
| | While the Rivers of Love Flow On (Geo. Graff, Jr.-Ernest Ball).....Wilfred Glenn | 10 |
| 17573 | Hesitate Me Around, Bill (Jerome-Franklin).....Collins and Harlan | 10 |
| | Celebratin' Day in Tennessee (Brown-Glogau).....Collins and Harlan | 10 |
| 35381 | Jewels of the Madonna—1st Entr' acte (Intermezzo between Acts I and II) (Wolf-Ferrari).....Victor Concert Orchestra | 12 |
| | Danse macabre (Saint-Saëns).....Vessella's Italian Band | 12 |
- TWO LATEST POPULAR HITS.
- 17584 This is the Life (Irving Berlin).....Billy Murray
 - Everybody Loves My Girl (Lew Brown-Nat. D. Ayer).....Billy Watkins
- TWO NEW MEDLEYS BY PIETRO.
- 17574 This is the Life Medley (Irving Berlin) (Accordion) Introducing "My Arverne Rose".....Pietro Deiro
 - Down in Chattanooga Medley (Irving Berlin) (Accordeon) Introducing "Kiss Your Sailor Boy Good-Bye".....Pietro Deiro
- TWO TUNEFUL MUSICAL PRODUCTION NUMBERS.
- 17572 Love's Hesitation, from "The Beauty Shop" (Maurice E. Marks-Chas. J. Gebest).....Edna Brown-James F. Harrison
 - Dream Girl o' Mine, from Chauncey Olcott's new play "Shameen Dhu" (Cass Freeborn).....Reed Miller
- RED SEAL RECORDS.
- By Caruso, Hempel, Duchene, Rothier, De Seguro, with Metropolitan Opera Chorus, G. Setti, director In Italian.
 - 89076 Masked Ball (Ballo in Maschera) (Quintetto, "E scherzo, od è folia"—Your Prophecy Absurd!) (Act I) (Verdi).....12
 - 88459 Les Rameaux (The Palms) (Jean Faure) In French. Tenor solo.....Enrico Caruso
 - 88453 La Traviata—Parigi o cara (Far from Gay Paris) (Act III) Soprano and Tenor Duet in Italian. (Verdi).....Lucrezia Bori-John McCormack
 - 88478 Gioconda—Suicidio! (Suicide Only Remains!) (Act IV) Soprano Solo in Italian (Ponchielli).....Emmy Destinn
 - 88479 Angel's Serenade (Gaetano Braga) Tenor Solo, with violin and piano accomp. In English.....J. McCormack, F. Kreisler and V. O'Brien
 - 87188 I Hear You Calling Me (Charles Marshall) Soprano Solo in English.....Lucrezia Bori
 - 74386 My Old Kentucky Home (Stephen Foster) (Soprano Solo in English).....Alma Gluck
 - 74387 Indian Lament (Dvorak-Kreisler) Violin Solo, piano by V. O'Brien).....Fritz Kreisler
 - 64423 Come Where My Love Lies Dreaming (Stephen C. Foster) Tenor Solo with Male Chorus in English.....John McCormack

INCORPORATED.

The New England Imperial Phonograph Co., Portland, Me., has been incorporated with capital stock of \$150,000 for the purpose of manufacturing and dealing in phonographs, records, etc. H. Knowlton, of Portland, is secretary and treasurer.

PAVLOWA AND THE GRAFONOLA.

The Internationally Famous Russian Dancer Pays a Great Tribute to the Grafonola and Columbia Records in Recent Letter.

A most notable testimonial to the merits of the Grafonola was received last week by the Columbia Graphophone Co. from Anna Pavlowa, the famous Russian dancer, whose tour in this country has been a continual chain of triumphs. From coast to coast Mlle. Pavlowa has been the subject of the most enthusiastic praise from well-known critics and artists, and her interpretations of numerous beautiful dances have been commended even through the medium of editorial articles in the country's leading newspapers. Her exceptional grace and charm have given a prestige to the terpsichorean art that has made her internationally famous.

Mlle. Pavlowa's praise of the Columbia Grafo-



Mlle. Anna Pavlowa, the Famous Danseuse.

nola and Columbia records, dance selections in particular, is embodied in the following interesting letter written under date of April 20:

"Since I have been in your country I have been amazed to see the popularity of the talking machine record when used with the dance. This so excited my curiosity that I have made it a great study and think it is due you to say that Columbia instruments and Columbia dance records over all others have my unqualified endorsement.

"I used your Grafonola and dance records in my rehearsals with complete satisfaction, and find your dance records truly represent the very spirit of the dance. Their tempo, rhythm, clarity and musical qualities simply charm me. I am convinced that all who dance can get great satisfaction from the use of your Grafonola and records. Sincerely yours, (Signed) ANNA PAVLOWA."

EMPHASIZED VICTOR CO-OPERATION.

In sending out its usual monthly batch of newspaper advertisements the Victor Co. called attention to the article published in the Philadelphia Ledger some time since, wherein the consistency of Victor advertising was described in detail. The company suggests that Victor dealers should take advantage of the co-operation offered them by the use of these regular Victor advertisements.

WHY OWN WEBSTER'S NEW INTERNATIONAL DICTIONARY

THE MERRIAM WEBSTER?

BECAUSE it is the only new unabridged dictionary in many years. BECAUSE it defines over 400,000 words, 2700 pages, 6000 illustrations. BECAUSE it is the only dictionary with the new divided page. BECAUSE he who knows *Why Succeed*. Let us tell you about this new work. WRITE for specimens of the new divided page, full particulars, etc.

G. & C. MERRIAM CO., Springfield, Mass.

Mention this paper, receive FREE, set of Pocket Maps



READ your trade paper! Get The Talking Machine World regularly—It is worth many times to you its annual cost.

There is but one talking machine paper covering this entire industry, and it is admitted by all that it is of great aid to the dealers in every part of this country.

New economic conditions make certain knowledge necessary on the part of merchants, and in every issue of The World there is contained educational matter, instructive service, business news and technical articles which are worth many times the cost of the paper.

Thousands have been benefited by the business articles which appear in The World, and every talking machine dealer should receive it regularly.

The only way to do that is to pay for it, and the cost is trifling—a little over eight cents a month, and for that small sum The World, with all its mine of information, is at your service.

If you do not receive the paper regularly, just put your dollar in an envelope and address it to the office of the publication, and you will say that it is the best investment that you have ever made.

Do not delay but send on your dollar now.

Recollect that your competitor is getting The World—getting it regularly, and in it he is securing some valuable pointers—information which places you at a disadvantage if you do not read the paper.

Do not overlook such a valuable contributing factor to your business success.

EDWARD LYMAN BILL

PUBLISHER

373 Fourth Avenue,

New York City

“Tell him what he
wants to hear”—

“Sell him what he
wants to buy”

These two basic selling rules
were old when the world
was young. You use them
with the utmost freedom in
selling the full Edison Line
because of its tremendous
variety of talking points.

No matter what your cus-
tomer's tastes, you can
always find some Edison
superiority he's been wanting
to hear about and so you
can *always* sell him what
he wants to buy.



Edison Disc and Cylinder Phonographs



Thomas A Edison
INCORPORATED

59 Lakeside Ave., ORANGE, N. J.

The TALKING MACHINE WORLD

AND
NOVELTY
NEWS

Published Each Month by Edward Lyman Bill at 373 Fourth Avenue, New York, June 15, 1914



Victor-Victrola XVI, \$200
Mahogany or quartered oak

The instrument by which the value of
all musical instruments is measured



Leading Jobbers of Talking Machines in America

Landay
BROS INC.

VICTOR JOBBERS Exclusively
What you want always in stock
400 Fifth Avenue
27 W. 34th Street
563 Fifth Avenue
153 W. 42d Street } **New York**

1856 **WURLITZER** 1914

VICTOR
DISTRIBUTERS
VICTORS EXCLUSIVELY

We make a specialty of getting the order out on time—every time.

The Rudolph Wurlitzer Co.
CINCINNATI and CHICAGO

Two points of supply; order from the nearer.

CHASE & WEST DES MOINES IOWA

Machines **Victor** Everything
Records in stock all
Cabinets the time.

WHOLESALE TO IOWA TRADE
Send us your name and address and we will mail you postpaid complete illustrated catalogues, giving detailed information concerning all Victor products. Showing the various styles of Victor Machines, list of all Victor Records, the entire line of Victor Cabinets, Repair Parts and all Accessories. Dealers, let us help you build a Victor business.

PERRY B. WHITSIT L. M. WELLER

PERRY B. WHITSIT CO.,

213 South High Street, Columbus, Ohio.

Edison Phonographs and Records **JOBBERS** Victor Talking Machines and Records

**OLIVER
DITSON
COMPANY**

Largest VICTOR Talking Machine Distributors East of Chicago.

Creators of "The Fastest Victor Service." Let us tell you more about our service.

BOSTON

W. J. DYER & BRO.

Saint Paul, Minn.

VICTOR & EDISON
Distributors

Quick Service for all points in the Northwest. Machines, Records, Supplies.

**VICTOR DEALERS
TRY US FIRST**

We carry the Largest Stock of VICTROLAS, RECORDS and CABINETS of any Distributor in the South.

THE CORLEY COMPANY, Richmond, Va.



Where Dealers May Secure

COLUMBIA

Product

Ready, Full Stocks, and Prompt Deliveries from Convenient Shipping Centers all over the United States.

Distributors

- Atlanta, Ga., Columbia Graphophone Co., 132 Peachtree St.
- Baltimore, Md., Columbia Graphophone Co., 805-807 North Howard St.
- Birmingham, Ala., Columbia Graphophone Co., 1818 Third Ave.
- Boston, Mass., Columbia Graphophone Co., 174 Tremont St.
- Buffalo, N. Y., Columbia Graphophone Co., 622 Main St.
- Chicago, Ill., Columbia Graphophone Co., 14 N. Michigan Ave.
- Cincinnati, O., Columbia Graphophone Co., 117-119 W. Fourth Ave.
- Cleveland, O., Columbia Graphophone Co., 1375 Euclid Ave.
- Dallas, Tex., Southwestern Talking Machine Co., 1403 Main St.
- Denver, Colo., Columbia Stores Co., 505-507 Sixteenth St.
- Detroit, Mich., Columbia Graphophone Co., 114 Broadway.
- El Paso, Tex., Southwestern Talking Machine Co., Stanton and Texas Sts.
- Hartford, Conn., Columbia Graphophone Co., 719 Main St.
- Indianapolis, Ind., Columbia Graphophone Co., 27 N. Pennsylvania St.
- Kansas City, Mo., Columbia Graphophone Co., 1112 Grand Ave.
- Lincoln, Nebr., The Grafonola Company, 1036 O St.
- Livingston, Mont., Schenber Drug Co.
- Los Angeles, Cal., Columbia Graphophone Co., 420-422 S. Broadway.
- Louisville, Ky., Columbia Graphophone Co., 425 South Fourth St.
- Milwaukee, Wis., Albert G. Kunde, 516 Grand Ave.
- Minneapolis, Minn., Columbia Graphophone Co., 424 Nicollet Ave.
- New Haven, Conn., Columbia Graphophone Co., 25 Church St.
- New Orleans, La., Columbia Graphophone Co., 933 Canal St.
- New York City, Columbia Graphophone Co., 89 Chambers St.
- Philadelphia, Pa., Pennsylvania Talking Mach. Co., 1109 Chestnut St.
- Pittsburgh, Pa., Columbia Graphophone Co., 810 Bessemer Building.
- Portland, Me., Columbia Graphophone Co., 559 Congress St.
- Portland, Ore., Columbia Graphophone Co., 371 Washington St.; Eilers Music House.
- Providence, R. I., Columbia Graphophone Co., 119 Westminster St.
- Rochester, N. Y., The Grafonola Company, 23 Clinton Ave., South.
- Sacramento, Cal., Kirk, Geary & Co.
- Salt Lake City, Utah, Daynes-Beebe Music Co., 45 Main St.
- San Francisco, Cal., Columbia Graphophone Co., 334 Sutter St.
- Seattle, Wash., Columbia Graphophone Co., 1311 First Ave.; Eilers Music House, 3d and University Sts.
- Spokane, Wash., Columbia Graphophone Co., 818 Sprague Ave.
- Springfield, Mass., Columbia Graphophone Co., 174 Worthington St.
- St. Louis, Mo., Columbia Graphophone Co., 1008 Olive St.
- St. Paul, Minn., Columbia Graphophone Co., 17 East Sixth St.
- Tampa, Fla., Tampa Hardware Co.
- Terre Haute, Ind., 640 Wabash Ave.
- Toledo, O., Columbia Graphophone Co., 229 Superior St.
- Washington, D. C., Columbia Graphophone Co., 1210 G St., N. W.

DEALERS WANTED—Exclusive selling rights given where we are not actively represented.

Write for particulars to the Columbia Graphophone Co., Wholesale Department, Woolworth Building, New York.

Headquarters for Canada:

Columbia Graphophone Co., 363-5-7 Sorauren Ave. Toronto, Ont.

SANGER BROTHERS
Dallas, Texas

VICTOR
Distributors

"We ship the same day."

Southern Victor Dealers

Largest Stock VICTROLAS and RECORDS. Prompt Shipment and Low Freight Rates.

WALTER D. MOSES & CO.
Oldest Music House in Virginia or North Carolina.
RICHMOND, VA.

Edison Phonograph Distributors
for the SOUTHWEST

All Foreign Records in Stock

Houston Phonograph Co., HOUSTON, TEXAS

NEW ENGLAND
JOBBOING HEADQUARTERS
EDISON AND VICTOR

Machines, Records and Supplies.

THE EASTERN TALKING MACHINE CO.
177 Tremont Street BOSTON, MASS.

PACIFIC COAST DISTRIBUTORS OF

Victor Talking Machines and RECORDS
STEINWAY PIANOS—LYON & HEALY
"OWN MAKE" BAND INSTRUMENTS

Sherman, Clay & Co. San Francisco Portland
Oakland Los Angeles

The Chicago Edison Jobber

The perfection of Musical Instruments—THE EDISON diamond disc PHONOGRAPH—with EDISON double disc records.

THE PERFECTION OF SERVICE—Our Service.

The Perfection of advertising for the dealer—Our plan.

The Phonograph Company
229 So. Wabash Ave. CHICAGO

Every Jobber in this country should be represented in this department. The cost is slight and the advantage is great. Be sure and have your card in the July List.

The Talking Machine World

Vol. 10. No. 6.

New York, June 15, 1914.

Price Ten Cents

ALL READY FOR BIG CONVENTION AT ATLANTIC CITY.

Officers of National Association of Talking Machine Jobbers Have Perfected Plans for Big Gathering to Be Held at the Hotel Chalfonte, Atlantic City, on July 6, 7 and 8—Indications Point to a Large Attendance—Arrangements Committee Working Hard.

Plans have all been completed for the big annual convention of the National Association of Talking Machine Jobbers to be held at the Hotel Chalfonte at Atlantic City on July 6, 7 and 8, and the only thing now lacking is the enthusiastic crowd of association members. The present prospects are that the Convention will be the best attended and most successful ever held under the auspices of the association, and the committee in charge of the arrangements, of which L. C. Wiswell is chairman, has spared no pains to lay out a program that will make every moment interesting.

In addition to a number of talks and discussions of a strictly business nature, but of great importance to the jobbers, and which will take up most of the time in the regular session, the matter of pleasure has also received due attention. The entertainment under this head will be automobile rides for the ladies, lunches, dances, cabarets and a big banquet on Tuesday evening, July 7.

The indications are that the banquet will be a record-breaker on the point of pure joyousness, for it will be held at Barney's Hotel, one of the most popular places in Atlantic City, and the excellent menu will be supplemented by an entertainment provided by the regular hotel orchestra and force of cabaret artists. One of the principal speakers in addition to the prominent members of the trade will be the Hon. Walter I. McCoy, Congressman of the Ninth District of New Jersey, who will address the jobbers on the subject of "Unfair Competitions."

On Monday night, after the strenuous day of association work, the members and their lady folk will adjourn to Barney's, where a balcony has been reserved for the party.

The officers of the association and the various committees have worked hard to insure a record-breaking attendance at the meeting. Postcards and letters galore have been sent to members to preclude any possibility of their forgetting the Atlantic City session. One of the reminders is in the form of a shipping tag, on the back of which appears the words, "Tie this string on the middle finger of your left hand so you won't forget the date of the big show. Selah!"

In his efforts to insure a big attendance, Chairman Wiswell, of the Arrangement Committee, even lapsed into verse, and was responsible for the following effusion in one of his letters to association members:

GOOD RECORD TURNS TRAITOR.

Old Couple Shocked When Sacred Record Produced Air of Popular Song—A Joke That Worked to Perfection—Has a Happy Ending.

The World of Records, the bright little magazine issued every month by the London organization of the Columbia Graphophone Co., tells the following good story:

"An elderly friend of mine once won a graphophone in a competition. One record only accompanied the instrument, a sacred piece, which was played over and over again, to the great delight of the old gentleman and his wife. Their knowledge of graphophones was very limited and they had no idea that records of other songs could be bought and played by the instrument. Getting to know this, I thought I would have some fun with the old couple. Having some records of the right size, I called on my 'victims' one evening and managed to substitute 'Salvation Nell' for their sacred tune record. Out came the instrument in due course,

BE A BOOSTER.

"Be a Booster, friend of mine,
It cannot do you harm;
'Twill give you prestige every time
To tell where you are from.

Don't be ashamed of what you do,
Speak out and let them see;
That you're a Booster thru and thru,
And a Booster you will be.

For the meeting place, Atlantic City face,
July, the merry time
We're going to make that Boardwalk shake,
With song and jolly rhyme.

It's up to you, it's up to me,
To Boost along the game;
Just be on hand and then you'll see
All troubles put to shame.

Get in line, say you'll go,
Let the other fellow see,
That you are ready now to show
What the Association ought to be."

Benj. Switky, chairman of the Reception Committee, not to be outdone, took "The Eighth Annual Convention" as the subject, and developed the following bit of verse, in which will be noticed that the first letters of each line taken together have a meaning all their own:

DEAR FELLOW-JOBBER, ATTENTION!

THE EIGHTH ANNUAL CONVENTION,
Hotel Chalfonte, Atlantic City, N. J.,
Expects your presence without fail.

Every Jobber should attend
In the interest of his business.
Go to Atlantic City, July 6, 7, and 8.
Hear, see and profit.
There will be lots to learn.
Have a jolly time incidentally.

And bring your wife and friends along.
No money was ever spent more wisely.
Never was time put to better account.
Urge your fellow-Jobber to attend.
All should work for the welfare of the Association.
Let's make this Convention a howling success!

Compare notes with fellow-members.
Opinions are wanted regarding certain policies.
New ideas will be proposed and discussed.
Victor record shortage will be explained—satisfactorily.
Everything of interest and profit will be reviewed.
No Jobber can afford to stay away.
The Victor Co. has some thing to show you.
Important announcements will be made.
Organized action begets results.
Notify Chairman Wiswell that you're coming.

This is going to be a wonderful convention! Everybody says so. Atlantic City is the favorite resort of the jobbers, and they will prove their interest in both the resort and the association by arriving there in large numbers.

and I think I never saw such a look of blank amazement as was pictured on the faces of that couple as their graphophone gurgled out the words of that song. They were as mystified as a prehistoric man might have been in similar circumstances. Before I went home I contrived to replace the original record, and until I took pity on them and explained how it happened, some weeks later, the pair were quite unable to account for that sad lapse of their strictly moral and religious graphophone."

RECORD DISPLAY STAND.

The Chambers street headquarters of the Columbia Co. sent to local dealers this week a record display stand that embodies a number of distinctive features which are making it very popular with the trade. The stand is very attractive in its design and a complete service of new record strips, together with the stand, is furnished the dealers at a cost of seventy-five cents per month for a period of six months.

DOLBEER GOES WITH VICTOR CO.

Popular Talking Machine Man Joins Victor Organization, Succeeding Oliver Jones, Who Resigns to Enter the Real Estate Business.

(Special to The Talking Machine World.)

CAMDEN, N. J., June 10.—Louis F. Geissler, general manager of the Victor Talking Machine Co., issued the attached announcement to-day:

"It is with much pleasure that we announce to the many business friends of F. K. Dolbeer, his affiliation with this company in the capacity of credit manager and for such other duties as his long experience in the talking machine trade has so eminently fitted him.

"Mr. Dolbeer will assume his duties with us on July 1, and we feel sure that his personal friends and ours will extend to him an unusually warm welcome to the Victor fold."

Frank K. Dolbeer, who recently resigned from his position as sales manager of Thomas A. Edison, Inc., to engage in the jobbing business in New York, is one of the most popular men in the trade, and has an intimate acquaintance with the talking machine jobbers and dealers throughout the country, all of whom entertain the warmest personal and business regard for him.

This new move will come somewhat in the nature of a surprise to his many friends throughout the trade, and he is assured of a warm welcome from Victor representatives everywhere.

Mr. Dolbeer will not begin his connection with the Victor Co. until the first of July, and he is at present taking several weeks' vacation at the Thousand Islands.

Oliver Jones, who has been connected with the Victor Co. ever since its formation, and whom Mr. Dolbeer succeeds, has resigned in order to enter the real estate field in Atlantic City and Philadelphia, where he has considerable holdings.

ARE THERE IDEAL DAYS?

The Advantage of Present Hustle—Many Salesmen Quick to Lay Down at Complaints.

The man that comes back a little stronger for every obstacle he encounters gets there just the same.

Good times in any locality are when everybody is feeling good and full of push. If there is any complaining in a certain section 80 per cent. of the salesmen, that is those with a weak spine, lay down.

Generally speaking, there is just as much business done in that locality as there was the year before, and the other 20 per cent. of the men that cannot be run out have a good deal better chance for business than they had before.

The business man gets to feeling that business is bad sometimes when there is only as much doing as there was in the year previous. He may be doing just as much business as he did the year before, and is just as well off. The only difference is in his condition of mind.

Of course, every business man likes to see business increase, but if it does not increase it is because he is waiting for something to turn up and does not go out and turn it up himself.

Everybody has his own troubles and succeeds in spite of them, or fails because his power of resistance is weak.

As a rule the man that glories in obstacles gets the most happiness out of business.

THE PORTER PHONETOSCOPE CO.

(Special to The Talking Machine World.)

DOVER, DEL., June 8.—The Porter Phonotoscope Co. filed a certificate of incorporation this week with the Secretary of State to manufacture phonetic apparatus for talking, singing and moving pictures. The capital is mentioned as \$1,500,000 and the incorporators as F. R. Hansell, Philadelphia, Pa.; George H. B. Martin and S. C. Seymour, Camden, N. J.

DEALERS AFTER SUMMER TRADE ON PACIFIC COAST.

Cheaper Grades of Portable Machines Being Advertised for Use at Cottages and Camps
—Various Houses Carrying Out Improvements in Their Quarters—Good Reports from
the Interior—New Manager in Seattle—Talker Music for Convicts.

(Special to The Talking Machine World.)

SAN FRANCISCO, CAL., June 6.—Emphasis is now being placed on the cheaper machines suitable for summer cottage and camp use, and considerable business has been done on this class of talking machines in the past two weeks, with indications that the demand will increase as the warm weather sets in and schools close, which marks the opening of the vacation period proper. The demand, however, is not confined to the cheaper products, as May generally was a very good month. All prices of machines had a normal call, and record business was thoroughly satisfactory, considering the general level of business in other lines. Some managers report a larger volume of business for May than April, and no complaints were registered in April. No falling off is noted as yet in the demand for dance records and none is anticipated by the local trade for some time to come. The tendency among talking machine interests of this city to seek more desirable locations and provide increased facilities is very good evidence that the trade is in a healthy condition.

P. H. Beck & Co. Plan Improvements.

P. H. Beck & Co., who operate the department on the mezzanine floor of the Kohler & Chase building, are the latest concern to signify intention of making improvements this summer. They are negotiating for additional space in the building adjoining, which will give them practically double the floor space now available. Mr. Beck has felt the need of larger quarters for several months and will begin the remodeling of the department as soon as possible. He plans to install seven demonstration rooms in the new space, which will be connected with the present quarters by an archway. He says May business in his department showed a gain over April.

Work on New Babson Bros.' Store.

Alterations started two weeks ago at the store, 235 Geary street, upon which Babson Bros. secured a lease a short time ago, and work is progressing nicely. The plans call for the installation of a new front and a general renovation of the interior, including the installation of several sound-proof demonstration rooms and a recital hall. Upon moving to the new quarters the firm name will be changed to the Phonograph Co. of San Francisco, which is a newly formed local corporation organized to take over the business. J. S. Baley will continue as manager, and Edison products will be handled exclusively at the new establishment the same as heretofore.

W. S. Gray Spends Much Time on Road.

W. S. Gray, Coast manager of the Columbia Graphophone Co., has not been at headquarters much the past month. A few days after his return from the Northwest he left for Modesto, Cal., to attend the formal opening of the new Columbia department installed by the Weil Furniture Co., of that city. While in that vicinity he called on the trade in the neighboring towns and later in the month made a trip up into Sonoma County, with Santa Rosa as his objective point, the principal object of his visit being to attend the formal opening of a new Columbia department by the Santa Rosa Furniture Co. Both the Weil Co. and the Santa Rosa concern have arranged to devote particular attention to their new departments. They have fitted up well-appointed quarters and have started with complete stocks of machines and records. Mr. Gray says the country looks fine all along the line and that dealers are in very good spirits over the outlook for fall business.

Columbia Business Keeps Up Well.

F. R. Anglemier, wholesale manager at the local Columbia warerooms, says business in both machines and records kept up in good shape the past month.

"Talker" Man on Long Auto Trip.

Charles Moran, manager of the talking machine and small goods departments of the Hauschildt Music Co., accompanied Henry Hauschildt, head of the firm, and family on an eight-day motor trip up to Lakeport, Mendocino County, the latter part of May.

Frank and Clarence Anrys in the East.

Clarence Anrys, of the Wiley B. Allen Co.'s talking machine department, left for the East on May 20 with his father, Frank Anrys, general manager of the Allen Co. They planned to be gone for five or six weeks, visiting various factories whose lines are handled by the company, including a visit to the factory of the Victor Talking Machine Co.

Retail Victor Business Grows.

Andrew G. McCarthy, treasurer of Sherman, Clay & Co., says their retail Victor Victrola business for May this year showed a gain over the corresponding month of last year, while the wholesale department held its own very well also.

New Manager in Seattle.

The Kohler & Chase talking machine department in Seattle, Wash., is now under the management of Andrew Love, who was formerly with the Columbia Graphophone Co. in that city, succeeding Mr. Dawley, who resigned a short time ago.

Columbia Leader Machines Popular.

A. A. Schell, manager of the Emporium music department, has just returned from a combined business and pleasure trip to Portland, Ore. He says business is keeping up in fine shape in the talking machine section, where the demand runs strongly to Columbia "Leader" machines. Many people were attracted to the department one day last week when a special recital of Margaret Woodrow Wilson's records was given.

Talking Machine Music in Jail.

An innovation has been introduced at the Alameda County jail by Sheriff Frank Barnet in the way of providing music during the social half hour from 4 to 4.30 each afternoon. For this purpose he has had a phonograph placed in the main corridor of the jail and has donated 100 records to start with, promising to buy more from time to time as requests are made. The entire expense of the machine and records was borne by the Sheriff, who stated upon making the purchase that he believed that the innovation would not only give pleasure to those serving sentence, but would serve as an aid in discipline.

Trade Shift at Long Beach.

The stock of talking machines, small goods, etc., of the Mason Music Co., of Long Beach, Cal., has been purchased by the Carlton Music Co., of that city. The Carlton Co. already had the selling agency for the Columbia Grafonola line, and by buying out the Mason Co. secured the agencies for the Victor and Edison lines. The son of Mr. Mason, of the retiring company, who was associated with his father in the business, has accepted a position with the Carlton Co.

IN NEW QUARTERS JUNE 1.

Ray Bros., who have built up a large talking machine business in Louisville, Ky., moved on June 1 from their old store at 308 West Jefferson street, to the new Paul Jones Building on Fourth street, where they have spacious quarters with a full equipment of sound-proof booths. The officers of the company are: C. A. Ray, Jr., president; L. J. Ray, secretary; H. G. Ray, treasurer.

TAKES ON TALKING MACHINES.

(Special to The Talking Machine World.)

ANAHEIM, CAL., June 6.—The Graham Furniture Co., one of the largest and finest furniture houses in this part of the country, located in this city, has just taken on the agency for the Edison disc phonograph. Albert Graham, who owns and conducts the enterprise, will take a strong personal interest in the new department.

Many a man who is credited with being wise enough to keep silent, is really growing deaf—but won't acknowledge it.

The Success of Your Talking Machine Department

Is to a *large* extent dependent upon the service your distributor gives you.
This admitted makes it important that you secure the best service obtainable.

AND THAT IS EASTERN SERVICE

To use it is to swear *By* it not *At* it.
May we not have the opportunity to convince you that our service is exceptional?

EASTERN TALKING MACHINE COMPANY

177 TREMONT STREET, BOSTON, MASS.

EDISON

FOR NINETEEN YEARS TALKING MACHINES EXCLUSIVELY

VICTOR

OUR DISC RECORD ALBUMS

ARE THE BEST FOR VICTOR, COLUMBIA
AND ALL OTHER TALKING MACHINES

THE ONLY CONVENIENT AND SAFE WAY TO PROTECT DISC RECORDS

These Record Albums will Pay for Themselves in a Short Time by Preserving Records.
When Full the Albums are Flat and Even Like Books. They will Fit in a Library
Cabinet or Book Case, or They will Lie Flat on One Another.

For Durability, Artistic Design and Finish, our Albums have no equal. They are made in the most substantial manner by skilled workman, and are first-class in every particular. We sell them at very low prices to meet competition.

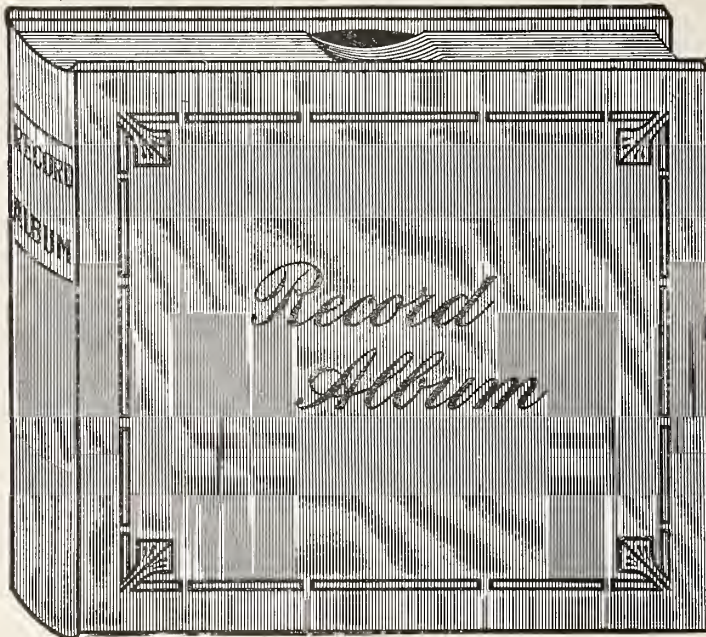

DISC RECORD ALBUMS

ARE WHAT EVERY
Talking Machine Owner

MUST NOW HAVE

With the index they make a complete system for filing away all disc Records, and can be added to, Album by Album, as Records accumulate, like books in a library.

Write for sample and prices of our Albums, which are superior to all others.

Address NATIONAL PUBLISHING CO., 235 South American St., Philadelphia, Pa.

THE EDISON SHOP IN ST. PAUL

To Be Opened by Laurence H. Lucker on July 1—Mr. and Mrs. Matheis on Auto Tour—Columbia Products with Golden Rule Store—Dance Instruction Records Much in Vogue—News of Month.

(Special to The Talking Machine World.)

MINNEAPOLIS AND ST. PAUL, June 8.—St. Paul will have a new talking machine palace about July 1 under the management of Laurence H. Lucker. It will be called the Edison Shop and will be located in the center of the best business district. Mr. Lucker says that he purposes to make this the finest retail phonograph store in the Northwest and will work hard for the retail trade in that city. It will have no connection with the Minnesota Phonograph Co. at 58 East Seventh street, St. Paul, which is controlled by Mr. Lucker's brother.

Speaking of the May business, Mr. Lucker said that the volume both in the wholesale and retail departments exceeded that of May, 1913, by 100 per cent. The indications are that the demand for Edison's instruments and records not only will continue but will greatly increase. A carload of \$80 disc machines, received June 2, is disappearing like mist before the sun.

Mr. and Mrs. Archie Matheis, of the Talking Machine Co., Minnesota, are planning an automobile tour from Minneapolis to the Victor works at Camden, N. J. They will leave about June 25 and are to be gone five or six weeks, camping out every night. They will tour through Iowa, Illinois, will make a short stop near Columbus, O., at Mrs. Matheis' former home and will then proceed east. A sleeping tent and a full camping outfit will complete their caravan. Mr. Matheis states that he has had great success of late with the new Victrola No. 11, which seems to fill a general demand, in Minneapolis at least. May business was beyond all expectations and June is likely to show equally large returns, as the annual migration from town to the lakes is stimulating the demand for machines, but particularly for records.

The new dance instruction records issued by the Columbia Co. are making a most decided hit in St. Paul and Minneapolis. With a set of these records any of the modern dances can be learned without a teacher, and that in short order, while the dance music selections are the best in their class. These records are being featured in all the Columbia publicity work campaigns in the Twin Cities and are expected to make a wide appeal to cottagers and campers at summer resorts of the Northwest.

C. P. Herdman, manager of the Columbia St. Paul store, will leave soon on a two weeks' vacation, which he will spend among friends and relatives in Cincinnati.

A rather unique advertising feature is being introduced by the Minneapolis Brewing Co., which, in order to advertise its new brew, "Zumalweiss," is giving away free talking machine records of a song in which the name of the new brew appears.

The Golden Rule department store, in its new building in St. Paul, which covers almost an entire block, will put in a full line of Columbia instruments and records in its talking machine department. It now handles only the Victor line.

WIN IN COLLECTING CONTEST.

Employees of the Branch of the Columbia Graphophone Co., in Washington, D. C., Prove the Victors and Are Entertained at Dinner—Some of Those Present.

(Special to The Talking Machine World.)

WASHINGTON, D. C., June 6.—Employees of the Columbia Graphophone Co. were tendered a banquet recently in celebration of the victory of the Washington office force in winning first prize in an account collecting contest, conducted by the main office. Those present included Harry C. Grove, local manager; William T. Graves, Howard E. Stewart, Raymond H. Keller, LeRoy McDowell, Charles Hill, Harry Green, Milton McIntosh, Charles Thomas, William Matthews, John Affatica, Henry McGee, Edward Wittier, Waldon Fawcett and Paul Cromelin.

"CANNED" TRAVEL TALKS NEW IDEA.

Hamburg-American Line Introduces Records Reproducing Lectures by Noted World Travelers Big Library Being Prepared.

A new attraction has been added to the talking machine by the introduction of travel talks, or illustrated lecture records. A famous lecturer is engaged to speak on some popular subject and his voice is "canned" just as in the case of some great singer. To complete the illusion of listening to an illustrated lecture in one's own home the record is illustrated by an attractively illustrated booklet. As the voice of the lecturer describes many famous scenes one has merely to turn the pages of the booklet to have the scene actually before the eyes.

A complete library of travel records delivered by the most popular lecturers is being prepared so that every taste may be satisfied. The records are of standard make and every care is taken to obtain perfect reproduction. The "canned" travel talk has many advantages over the original lecture. If one wishes to linger over a particular scene the lecturer will very obligingly repeat his travel talk or any part of it.

The first of these travel records entitled "A Day in Berlin," prepared and delivered by E. M. Newman, has proved an instantaneous success. Thousands of owners of phonographs who are constantly looking for some new record have taken advantage of this unique educational feature.

The records are prepared by the Travel Record Department of the Hamburg-American Line and sold at the nominal price of twenty-five cents, to cover packing and shipping. The record will be followed by similar travel talks on Paris, London and Hamburg. Other records will describe and illustrate a trip in a Zeppelin air ship, and short trips in Germany, France, England, the Land of the Midnight Sun, and a description of the "Waterland," the world's largest ship.

Idle clerks are a sign of a lazy manager.

THE VALUE OF ADVERTISING

is Now Recognized by Progressive Men in All Trade Fields—Like the Magnet It Draws Trade in Unexpected and Unaccountable Ways—How It Compares with Electricity.

Advertising is a magnet of unmeasured strength. It draws trade in unexpected and unaccountable ways. Like electricity, it is an art yet in its infancy, and while it has been wonderfully developed its unknown possibilities are far greater than those with which we are all familiar.

Electricity is daily surprising us with new miracles, none of which is more marvelous than wireless telegraphy. An apt illustration of the way in which wireless spreads to every quarter of the world is that given by a country school teacher, who likened it to the effect on a pool of water when a stone is cast into it and causes rippling waves to spread out over a large surface. The same idea can be applied to advertising. Words placed in a good advertising medium are distributed over large areas and messages sent out reach many people who would otherwise never know of the existence of the advertising firm.

Like electricity again, advertising is a wonderful current revivifying and oftentimes rejuvenating a business that has fallen into a rut or become dormant. Yet, like electricity, advertising is dangerous to fool with. Woe to the man who advertises falsely! His business electrocution, or at least severe burns, are sure to follow a current of words carelessly handled.

The results of advertising are measured in dollars and cents, the meter being the cash drawer—again proving similar to the electrical current, its strength being measured in watts and candlepower.

Both are mighty factors in the modern development of business, but both advertising and electricity have often been improperly employed in the past, being used as trick performers use other novelties to confuse and puzzle, rather than to enlighten the people. However, the public is only momentarily dazzled, and, unless these strong fac-

tors are properly handled, like a flash the power is short-circuited and the value lost.

The wise advertiser will store up his energy and charge his batteries only with reliable information, and will find that, with truth as a foundation, his messages will be considered of sufficient value to be carried far beyond their measured destinations, and returns will flow in from various unknown quarters.

NEW DEPARTMENT IN INDIANAPOLIS.

New York Store, One of the Largest Department Stores in the City, to Handle the Victor Line—General Run of Trade Excellent—Fraud Advertising Receiving Attention.

(Special to The Talking Machine World.)

INDIANAPOLIS, IND., June 8.—The New York Store, one of the largest department stores in the Middle West, situated in East Washington street, Indianapolis, has opened a Victor talking machine department. Practically all the large department stores now have such a department. The New York Store will obtain its machines and records from the Stewart Talking Machine Co., jobbers in Indiana for the Victor Co.

Although the mercury has been climbing higher, the demand for dance records has not diminished in the Hoosier capital. The record put out by the Columbia Graphophone Co. explaining the tango step is having a large sale.

While there appears to be a slump in the piano business, talking machine dealers assert that they are surprised at the manner in which business in their line is holding up. Slack trade is expected at this time of year, but the talking machine dealers say they have no grounds for complaint.

The Victor department of the Aeolian Co.'s branch house here is enjoying an excellent trade for this time of the year. While this department is filling the big demand for dance records, classical records are also being sold often. More records are available now than for the last few months.

One of the windows of the Columbia Grapho-

phone Co., in North Pennsylvania street, is attracting wide attention. Life-size plaster paris figures of an infantryman and a dreadnought gunner occupy the center of the window and several army muskets which could tell tales of bloody battles in the Civil War are on display. The window was designed by H. M. Wright especially for Memorial Day. The large crowds in the city for the speedway automobile race paid particular attention to the unusual display.

One division of the Chamber of Commerce is paying attention to fraudulent advertising. This division is paying for advertisements in the local newspapers, requesting persons who suffer through such advertising to make known to the division that advantage has been taken of them. An attorney has been employed to handle such cases.

Little sensational or alleged fraudulent advertising from musical instrument houses has found its way into Indianapolis newspapers, but there have been one or two complaints. It is the object of the Chamber of Commerce to wipe out fraudulent advertising and thus strengthen the confidence of the buyer in the representations made in newspaper advertisements.

Local talking machine men and managers of piano houses are thoroughly in accord with the plans of the Chamber of Commerce along these lines.

ATTRACTIVE VICTOR FOLDER.

The Victor Talking Machine Co. sent out to its trade recently an attractive four-page folder giving a list of the Victor dance records that have been personally selected by Mr. and Mrs. Vernon Castle for use at Castle House and on board the Hamburg-American line steamer "Victoria Luise," where a Castle House instructor will teach the modern dances on her various cruises. The cover showed, in two colors, Castle House on Forty-sixth street, New York, and the "Victoria Luise," which is one of the most popular ships now making cruises to different parts of the world. The Victor records listed include tangos, maxixes, hesitation waltzes and one-steps.

Victrolas and Record Stocks Short

Be just to yourself and your customers

You owe it to yourself and your customers to give us a trial at filling your orders before you lose a sale by telling them that you "haven't got it and can't get it."

We cannot truthfully boast

about the completeness of machine and record stocks; nevertheless you can get from us certain types of machines and many selections of records that are not to be gotten elsewhere. New numbers are coming in daily.

TAKE NOTHING FOR GRANTED UNTIL YOU HAVE TRIED

BENJ. SWITKY, Victor Distributor NEW YORK, N. Y.

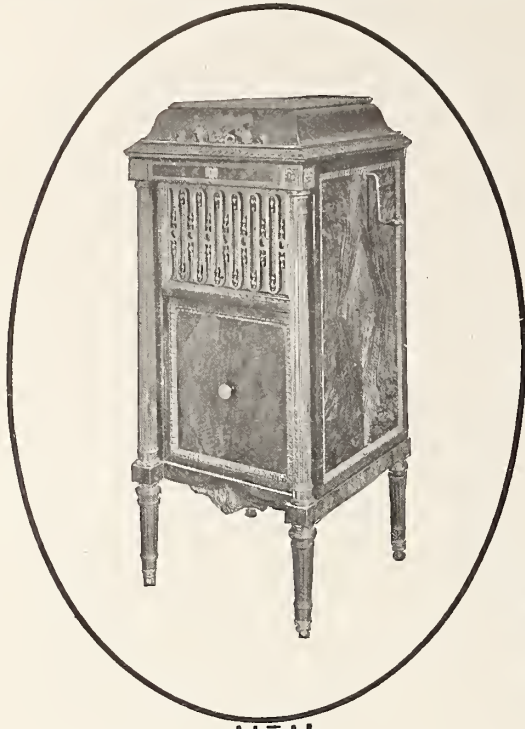

LOUIS XVI
Model A450, Circassian
Walnut, \$450.00
Model A400, Mahogany,
\$400.00



SHERATON
Model A210,
Mahogany,
Plain, \$500.00

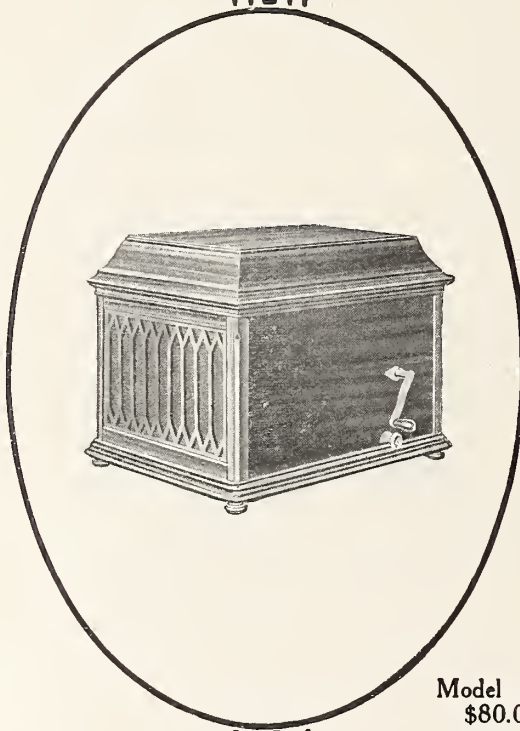

Model A80, Mahogany,
\$80.00

Edison Phonographs Speak for Themselves

Always, everywhere, the Edison Phonograph, whether Diamond Disc or Amberola, has proved itself its own best salesman.

It does more than speak for itself—it sells itself.

Most people know a good deal about phonographs these days. They know a good phonograph when they hear one.

They know what it means to have all the bother of changing needles completely eliminated.

They can appreciate Edison tone, the full sweet tone that brings out the true quality of the original music—and *all* of it.

Thomas A. Edison,



Model A200, Mahogany
and Oak, \$200.00



Model A50, Circassian
Walnut,
\$300.00



RATON
290, Ma-
Inlaid
quetry,
00

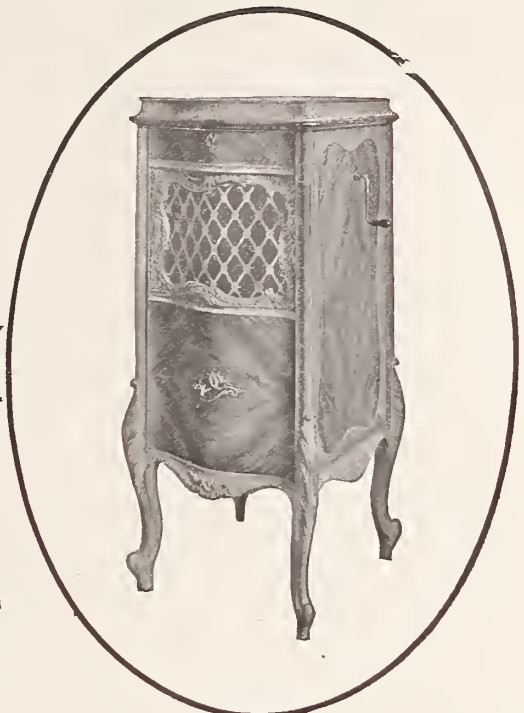

LOUIS XV

Model A425, Circassian
Walnut, \$425.00
Model A375, Mahogany,
\$375.00

They are mighty glad to find records that the children can easily handle.

They like a phonograph with volume of tone that suits it for singing music and out-of-door use.

They are quick to notice Edison steady speed and constant pitch.

And last, but by no means least, they appreciate the tastefully finished Edison cabinets that fit in with any scheme of interior decoration.

That is why Edison dealers have found that people who really love phonographs are always their best prospects.

The nearest Edison jobber will give you full details as to price and terms.

We shall be glad to give you his name.

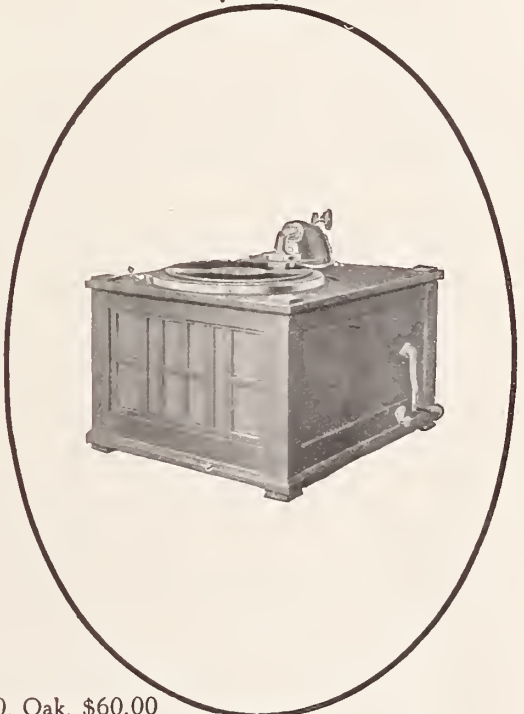

Model B60, Oak, \$60.00

Lakeside Ave., Orange, N. J.



250, Ma-
and Oak,
00



Model A150, Mahogany
and Oak, \$150.00

A FEW BUSINESS SUGGESTIONS FOR THE DEALER.

Benj. Switky the Prominent Victor Distributer of New York Discusses Means for Improving Summer Business and Proper Methods of Store Cleaning and Urges Early Preparation for Fall Trade—Machine and Record Stock Should Be in Perfect Trim.

Even at the risk of being called a garrulous, meddlesome, would-be-know-it-all, I can conceive of nothing more beneficial than to talk to dealers and salesmen about their own affairs. The object is not so much to impress upon them my own ideas as to spur them on to devote more time and thought to the upbuilding of their business. Should some of my suggestions sound so simple as to seem silly or superfluous please remember, dear reader, that I am talking to the other fellow and not you.

What are you going to do this summer? Have you any definite plan of action? While we don't like to admit it, it is a fact, nevertheless, that business falls off somewhat with most dealers during the summer months.

Suppose we were to plan a campaign of activity to offset the inactivity. I would suggest dividing the campaign into three sections, as follows:

1. How to improve summer business.
2. General store-cleaning.
3. Anticipating fall business.

How to Improve Summer Business.

Feature as strongly as possible the small size Victrolas and the dance records. Right now is the time to make an attractive window display, calling attention of passers-by to the advantages offered by the little Victrolas as regards quality, price, portability and easy terms.

Many owners of large Victrolas will welcome the suggestion that they take a small machine with them to the country, rather than risk carting the big machine to and fro.

Some of the prospects that you have been working on and which are not likely to be consummated as sales until next fall can be closed at once by offering to sell them a small Victrola for summer use, with the promise of redeeming it at full value in the fall when they are ready to get the big machine.

It might also be well to offer to rent a number of small machines at moderate charge, to encourage the sale of records during the summer.

This summer there will be a golden harvest for those dealers who will plug hard for the suburban, country and seashore trade. House-to-house canvassing, with a sample machine and records for demonstration, will bring the results.

The dance craze is neither a past nor passing fancy. The European love of outdoor dancing will yet be transplanted to this country—and this summer you will see the beginning. The small machines, from \$15 to \$50, together with popular

dance records, will surely be greatly in demand.

Of course, it is to be hoped that the manufacturers will be on the job and see to it that the supply shall be plentiful; otherwise it will be another case of "the best laid plans of mice and men (jobbers and dealers) aft gang alee."

General Store-Cleaning.

Begin by taking inventory, if you have not already done so recently. The benefits are two-fold: If the returns show favorably, you cannot help but feel optimistic in spite of the lull in business—which is a good way to feel in the summer time. If the stock taking figures poorly, it will act as a warning that something is wrong somewhere.

Next you will tackle the instalment and the charge accounts—those which have been overlooked or neglected. You should make these accounts mark time and keep in step. Then you will get after the surplus stock. In the summer time you are able to devote a little extra time and effort in trying to work off surplus.

Some dealers will discover, through their inventory, that they have scattered about the store a lot of miscellaneous machines which were taken in exchange during the past few months. With a little attention, these nondescript, more-or-less junky outfits can be put in salable condition—missing parts replaced, motors overhauled, etc. Every time you sell one of these outfits it feels like finding money, or at least like doing business on a hundred per cent. margin.

Do you regularly run your fingers through your record stock just to see if any records are misplaced? If not, try it! You will find it worth your while.

Overhaul your mailing list. Cut out those names which you know to be valueless. There are several ways of testing the value of names on your list. Have made a little rubber stamp, which will imprint on every envelope the words, "If undeliverable, sender will forward postage for return," or words to that effect. Or, by using two-cent stamps occasionally, instead of one-cent stamps, the post-office will return all mail that is undeliverable for any reason.

A still better way is to send out double post-card asking your customers to use the reply card to let you know whether they are interested in receiving the monthly supplements. You will then be in a position to strike off the list the names of those who did not feel it worth while to respond.

Every retail store will supply quite a lot of just

such work, and summer is the best time to do it.

Anticipating Fall Business.

There are still a goodly number of stores that are not tuned ready for playing. There is room for inexpensive, but much-needed improvement in the way of attractive interior decoration and arrangement. The installation of soundproof rooms is a good summer resolution. This work should be done now. Don't be like the fellow that Uncle Josh tells us about—the chap whose house had a leaky roof. When it rained he couldn't fix it, and when it wasn't raining it didn't need fixing. It is no excuse to say that when you are busy alteration or building is impossible, and when you are not busy you do not feel like spending the money. Remember the past and prepare for the future.

The outside appearance of the store should receive some thought, also. A good impression is the first requisite to a sale. Outside signs that catch the eye from a distance of 100 or 200 feet are equivalent to a saving in rent. They give you the prominence to be had only by a store near the corner, and we all know that rent is highest at the corner.

The final act of preparedness in anticipation of fall business is to get your machine and record stock in perfect trim—as perfect as conditions will allow at least. You are now ready for the real rush. It will come, and you will get your share because you will have done everything to deserve it.

CONDITIONS IN TEXAS

Discussed by Rafael Cabanas, President of the Mexican Phonograph Co. and the Southwestern Talking Machine Co. of Dallas and El Paso—Mexican Situation Discouraging.

Rafael Cabanas, president of the Mexican Phonograph Co., Mexico City, Mex., and the Southwestern Talking Machine Co., Dallas and El Paso, Tex., all of which are exclusive Columbia dealers and distributors, was a visitor for a few days this week at the executive offices of the Columbia Graphophone Co., Woolworth building, New York.

In a chat with The Review Mr. Cabanas spoke very encouragingly regarding the Dallas house of his company, stating that so far this year all previous records for corresponding months have been broken. The company but recently moved into larger quarters, which were made necessary by its increased and rapidly growing business. The El Paso branch is also making satisfactory headway and doing a very pleasing business notwithstanding its close proximity to the Mexican border and a general business depression in this part of the State. The Mexican situation shows no change for the better and the immediate outlook here is not encouraging.

The DITSON Pledge

Is to see that our clientele has a better service than ever—setting a new standard in Victor jobbing deliveries. The demands of alert Victor dealers—the kind that grow—are many and varied, and we furnish the "first-aid" in every instance.

We believe this year's Victor business will be of tremendous proportions, and it will pay you to have

The Fastest Victor Service

which is a requisite in this hustling age. We possess the largest stocks, the best organization and most up-to-date equipment in the Eastern half of the country.

This covers Victor machines, records and supplies of every kind, not to mention cabinets, needles and trade-marked accessories.

Will you let us tell you more about Ditson co-operation? A postal gets this information!

OLIVER DITSON CO., Boston, Mass.

As an aid in the schoolroom the talking machine now ranks foremost, and in addition it is recognized as the greatest assistance in acquiring a correct understanding of music. The layman in the home of refinement considers music a necessity, and the talking machine as an entertainer in home life is becoming a wonderful force.

EFFECTIVE means of publicity has helped very materially to increase public interest in the talking machine and the advertising end of the business is more than kept busy with the rapid strides in popularity made by this product the past year.

A word regarding a national advertised product.

This is maintained by experts as symbolic of the very highest type of modern publicity, and in view of the consistent and impressive magazine and newspaper advertising carried on by the great manufacturers it is not to be wondered at that the sales of talking machines and records are steadily growing.

PPRICE maintenance on patented articles does not mean a monopoly. On the contrary, it affords a legitimate protection to the trade and to the public.

In order that business may be conducted along sound, progressive lines, it is necessary that the customer should have confidence not only in the quality of the article, but in the fairness of the price which he pays.

There is a tremendous element of strength afforded talking machine dealers by standardizing prices, and price maintenance is a trade principle that every talking machine merchant, as well as every merchant in other lines should be interested in, for price maintenance means that uncertainty and haggling are eliminated—like-wise unjust discrimination among customers.

It guarantees for the purchaser a standard of quality, and there is no other way in which a high standard of value is secured in the retail world than through a uniform selling price.

The large department store, with its millions of patrons, cannot sell standardized or price-regulated articles cheaper than the small man who has a small store stowed away in an inconspicuous place in a town remote from the great cities.

Price maintenance is protection for all, and it does away wholly with the system of cut-throat practices which in the end are bound to demoralize business.

American people are becoming better and better educated as to value all the while, and they have, through arguments which have been made in many journals throughout the land, become acquainted with the advantages of fixed prices. They realize that it means protection to the public, and it behooves every business man to use his influence to the greatest extent to see that fixed prices are maintained.

WHEN the manufacturer maintains his price he is naturally compelled to maintain his quality, and as a result, throughout the mercantile world, a number of standard articles have been familiarized to the people of the country who can judge the qualities of articles within their own class.

National advertising of trade-marked articles has cleared the atmosphere, and has removed many disagreeable features from the retail department. Had there been no standard trade-marked creations there would have been comparatively little national advertising, and with no national standards.

By maintaining standards the people have been gradually educated in special values so that to-day they know that when claims of quality are made by national advertisers that those claims can be substantiated in a large degree.

Price maintenance is closely associated with national advertising, for no individual or corporation can afford to advertise a certain brand of goods if the quality of the advertised products are lowered as the demand grows through advertising.

No one can afford to advertise inferiority and expect to remain in business.

SPECIAL World reports from various parts of the country indicate that general business is not up to grade. There is little buying of merchandise, save to meet with present demands, but one of the best reasons for optimism at the present time is found in the promise of bountiful crops.

The new official estimates of the combined winter and spring wheat prospects indicate a promise of a total wheat harvest of 880,000,000 bushels, or 127,000,000 bushels more than last year. That fact alone is pleasant to contemplate, because it affords a foundation for stable business, and adds confidence in the trade situation which needs all the bolstering up possible.

THERE ought to be no more doubt as to a business man's duty when he hears false business doctrines presented than there is about the physician's duty when he hears a man putting false notions into the minds of the untutored regarding, we will say, the germ theory of disease.

Everybody is interested in business, and if they only knew it, not simply in the innumerable details which enter into business transactions, but in the principles which underlie these transactions, principles which the vast number have no grasp of.

Our time is so mortgaged to the succession of events that we fail to realize what significance there is in them, with the result that when things go wrong we make a hit and miss guess at the cause and probably lay the blame on some incident having no more relation to the wrong results than gold buried 400 fathoms under the sea has to the high cost of living.

Every decision in business based upon prejudice is helping to build up the mountain of obstacles in the progress of business toward a stable position. Therefore is it not the duty of business men to shake men out of their prejudices, not roughly, nor with that air of superiority which always defeats good purposes, but perhaps humorously, always good-naturedly, through that power of persuasion which comes by studying men's whims?

Many are all the while letting slip the opportunity to give a new or wider vision. In other words, to lead the men prejudiced by narrow outlook into a rational view. If a man has a lazy streak in him, the temptation is to let the fellow with the false notions wallow in them.

Beka Records

IN ALL LANGUAGES OF THE WORLD

High grade selections in

German, English, Italian, Spanish, Portuguese, French, Swedish, Slavonic, Ruthenian, Danish, Norwegian, Russian, Polish, Hungarian, Bohemian, Rumanian, Tschechisch, Croatian, Servian, Hebrew, Turkish, Persian, Arabic, Chinese, Malay, Japanese and seventeen different Indian dialects.

The cheapest and best machine on the market for \$2.50 upward

BEKA-RECORD AKT. GES., Berlin, S. O. 36 (Germany)

CATALOGUE IN FOUR LANGUAGES SENT FREE ON REQUEST

ANALYZING THE HUMAN SINGING VOICE.

Some Developments of the Research of New York Professors That Should Prove of Interest to Makers and Uses of Talking Machine Records—The Human Voice as Compared with the Tones of Various Instruments—How It Appears on the Records.

Until the present day the nearest approach to accuracy in the gauging of musical tone has been afforded by the human ear. Those interested in the development of their own voices or of the voices of singers or students have been as dependent upon the not altogether faithful and infallible judgment obtained by the individual sense of hearing as the importer or distributor of tea or coffee is dependent

nature and derived from abstract and not from physical subjects. This is shown by the indefinite terminology used by the voice teachers and critics in their work of vocal tone description. On the other hand, the sense of sight is held to be the most accurate and unfailling, because it has the advantage of a permanent material object that may be deliberately studied and analyzed. It is by far the most discriminating sense we have, and therefore impressions received through it are capable of exact description.

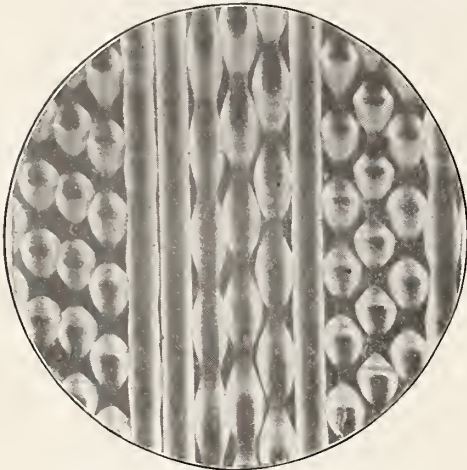

Soprano Song, "My Dreams."

upon the verdict of the professional sampler, or taster.

As the sense of taste is seldom exactly the same with two persons, and tea tasters will often be found to disagree as to the flavor and quality of a brand they may be sampling, so the sense of hearing is subject to disagreement—the more so, indeed, because its impressions are of a transitory

Photographic tone analysis is an ultra-modern device of science, which promises to exert a vital influence upon the development of the voice, as, indeed, it may also, upon the manufacture of musical instruments. It is in the formulation of the theory of correct tone production that the exact analysis of tone by photography has accomplished its most valuable function thus far.

Dr. Floyd S. Muckey, of New York City, who was associated with the late William Hallock, professor of physics at Columbia University, in a scientific investigation of the physical laws of the voice which lasted more than twenty years, has

evolved a scientific method of voice production, a method which especially takes into consideration the factor of interference with the correct action of the voice mechanism. It is by photographic tone analysis that he specifically sets forth the part which interference plays in preventing the full use of the vocal capabilities. Interference is also shown to be the direct cause in the deterioration of the vocal instrument. He accomplishes his analysis of vocal tones, and, likewise, his analysis of instrumental tones by the use of the Koenig manometric flame

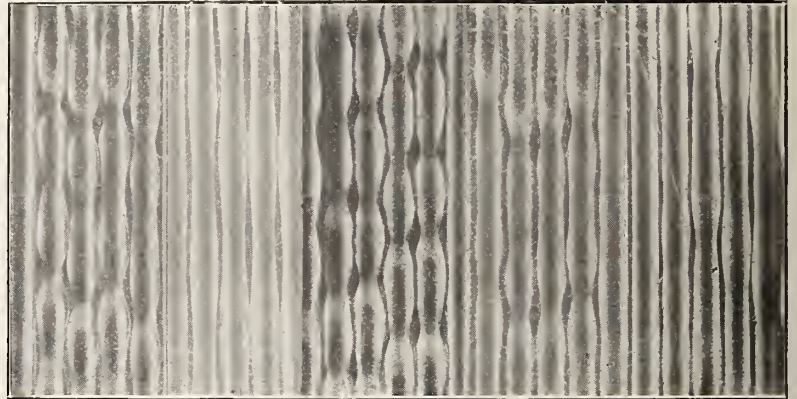

A E I O U
Tenor Voice Sounding Vowels in E Flat.

analyzer which has been greatly improved for this work by Prof. Hallock.

The photographic "tone analyzer," as the apparatus might more popularly be termed, provides an actual and permanent record of tone quality and shows the definite convention of cause and effect between interference with the mechanism and the resulting tone. How these tone photographs bear out the principles advocated by him is thus outlined by Dr. Muckey in the Scientific American:

"The roof of the mouth ends posteriorly in the soft palate, which rises in the act of swallowing to prevent the entrance of food into the cavities of

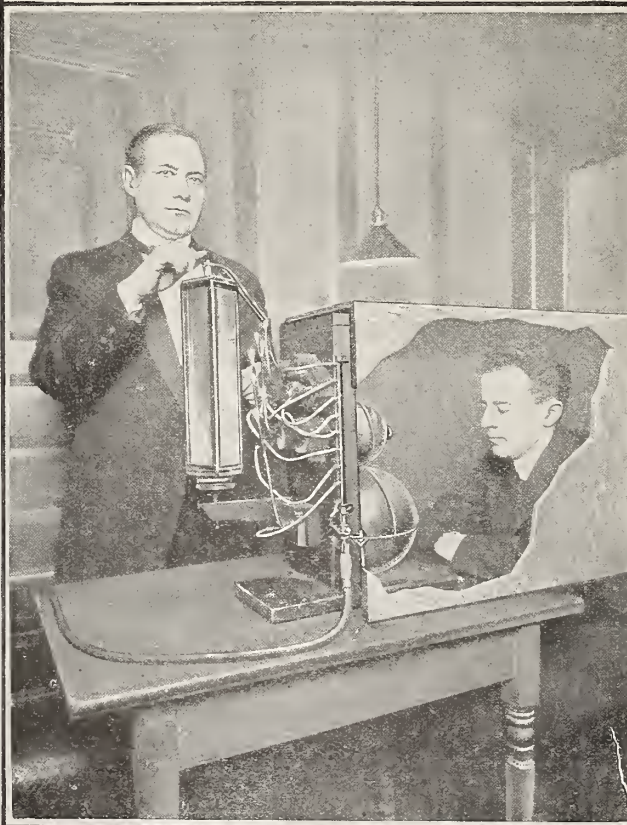
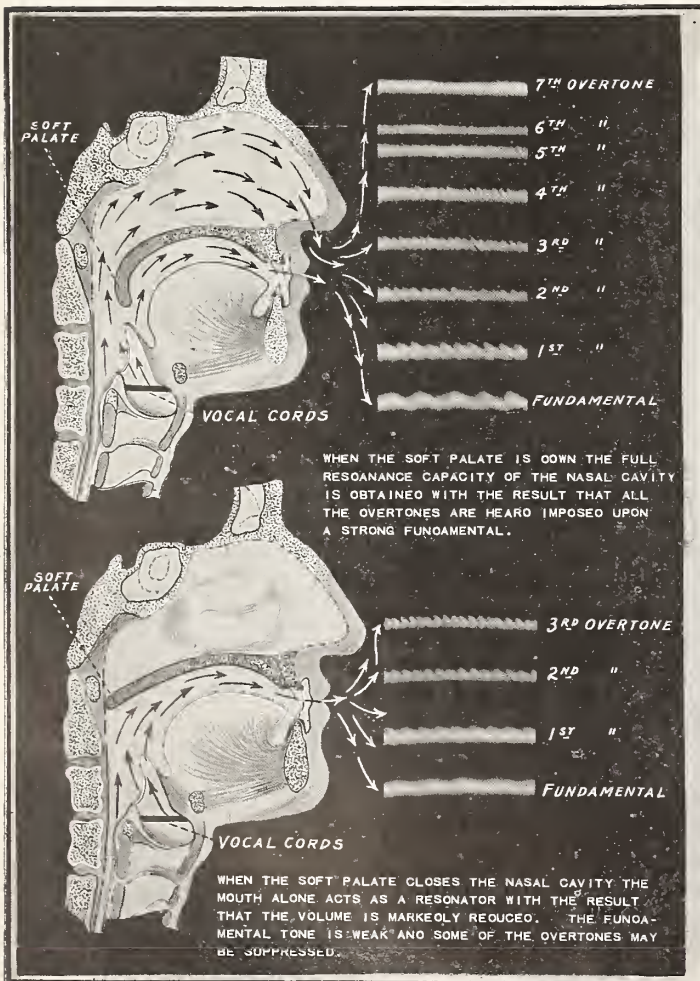

—Illustration by courtesy of Scientific American.

The Koenig manometric flame analyzer consists of a number of Helmholtz resonators connected by tubes with gas jets. As the subject tested sings, the flames vibrate. They are reflected in the vertical mirror, which the operator can turn by hand, so that the vibrating flames are seen as in the photographs on the left hand side of this page. The mirror is not used in making the photographs; a plate holder in a camera is merely shifted laterally during exposure, thus producing the effect shown in our picture. Before the late Prof. Hallock of Columbia University improved the Koenig manometric flame analyzer photographs such as those reproduced on this page could not be made. Experimenters made drawings by watching the reflection of the flames in the mirror. The photographs herewith reproduced are among the first ever obtained by means of the Koenig apparatus.

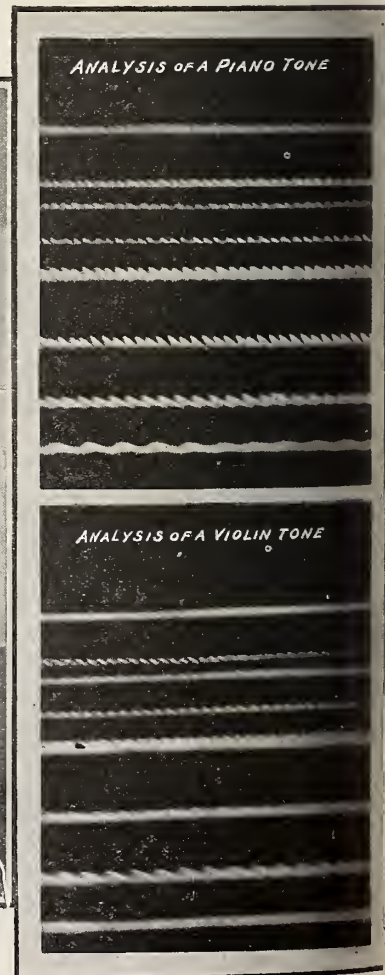

Tones of the pianoforte and violin, respectively, sounded upon lower C. In the piano record the fundamental tone represented by the first line is weak, but the overtones are highly developed. In the violin record the lower line, being bass C (128 vibrations), records no air-waves, because air-waves of that length were not sounded; the second line is the octave of bass C (256 vibrations) and the fundamental of this set of partials

The effect of correct and incorrect placing of the soft palate is shown by the photographs of tones appearing opposite the mouths. Note that when the full resonance capacity of the nose is used, as in the upper picture, a strong fundamental tone with good overtones is obtained; the lower picture shows how markedly poor is the effect when the soft palate is up. The photographs of the fundamental tones and the corresponding overtones, appearing opposite each drawing of the human head, were obtained by means of the Improved Koenig manometric flame apparatus shown in the center engraving on this page. They give instrumental evidence (better than any personal opinion) of the effect which the position of the soft palate has on tone production.

SHOULD A JOBBER ADVERTISE AND WHY?

By B. W. Smith, of The Phonograph Co., Cleveland and Cincinnati.

The question at the head of this article belongs to the same class as the classic "Is water wet?" The answer is so obvious that one wonders why it should be asked at all. As a matter of fact, however, it is asked for the main purpose of bringing out how and when the jobber should advertise in order to stimulate trade in his territory.

In the first place it needs no argument to prove that the most complete co-operation between the dealer and the jobber is necessary in order to produce the best results, and as a step in this direction a systematic advertising campaign on the part of the jobber is one of the most useful and profitable undertakings that can be entered upon.

The dealer, especially the small dealer, has neither the ability nor the knowledge to advertise in a business-building manner, with the result that whatever money he may spend in this direction is largely wasted and quite likely to have the adverse effect of making him think that because his advertising did not sell phonographs there is something wrong with the machine, for he will certainly never admit to himself that the trouble is with his own inefficient advertising.

The jobber, however, with his greater experience, wider knowledge and general grasp of the entire field and the problems in it, is in a position to secure the knowledge of just when and how to advertise. He is able to appreciate the fact that there is very little to be gained by haphazard methods, and everything by planning and carrying through a systematic, carefully worked up campaign. In certain cases he will find it to his advantage to furnish copy and advice for the publicity work of the dealer, but entirely apart from this he should maintain a distinct plan of his own, carefully worked out on a proved scientific basis such as will inevitably produce results in due time.

The old days of hit and miss guesswork in advertising have gone never to return, and in their place has come a scientific knowledge of the principles of publicity, as well as the appreciation of the fact that no one medium is sufficient in itself to answer all the requirements of any given campaign. In other words, the advertiser must study his field and make use of every possible means of securing legitimate publicity.

When a jobber does this he cannot fail, in the course of a reasonable time, to impress upon the minds of the public at large the fact that the Edison phonograph is something to be reckoned with, that it has features superior to all other phonographs, says Mr. Smith in the Edison Phonograph Monthly, that its merits do not have to be taken for granted, because the public is invited to compare it rigidly with any other machine and to note its superiority. There is no cause for evasion of any kind, because the Edison is actually the best and, as such, invites rather than wishes to avoid competition.

Should a jobber advertise? Most certainly and

decidedly, yes. But let him not go blindly into the wide field of publicity and stray around without fixed ideas. Let him carefully plan his line of action with the advice and assistance of someone who knows, and then he is able to go ahead with the absolute knowledge that every dollar he spends is an actual investment that will bear fruit in due season.



A NOCTURNAL RECORD ARTIST.

When the creek's silver mirror,
And the moon rides round and high,
And the whip-poor-will is calling
Across the windswept sky—

Then the great horned owl sits blinking
On the gnarled old maple limb.
Why don't you get your phonograph,
And make a date with him?

For his bass is rich and mellow,
And his song, though quite forlorn,
Will thrill all nature lovers
When rendered through a horn.

So I pray you, record makers,
To consider my avowal,
And list within your catalogs,
Solos by G. H. Owl.

HOWARD TAYLOR MIDDLETON.

Recently some office men with Chinese signatures have started the commendable practice of having their names written in type at the left of the signature. Splendid! Let us hope that others who delight in executing fancy strokes to the inconvenience of their friends will do likewise.

The egotist wouldn't be satisfied with himself unless he felt that everybody else was also satisfied with him.

BIG CONVENTION ATTENDANCE.

Arrangement Committee Believes That All Previous Attendance Records Will Be Broken at the Big Talking Machine Jobbers' Meeting at Atlantic City—Business Session Will Be Consummated in One Day—Interesting Demonstration by the Victor Co. of Departmental Work—Attractive Program Arranged.

Preparations for the 1914 convention are shaping themselves rapidly under the able management of the arrangement committee of the association, headed by L. C. Wiswell.

The tentative program given out by the arrangement committee shows the business session of the convention on Monday, July 6. It is the intention of the officers to inaugurate this year a one-day business session by calling the meeting to order on Monday morning and not considering a motion to adjourn before the meeting is all closed up. It is thought that this plan will be an improvement over the one previously used of having three or four business meetings of short duration. A buffet lunch will be served in the meeting room. Ladies will be entertained at luncheon and taken for an automobile ride during the afternoon. Monday evening there will be an entertainment at Barney's for all. Plans for Tuesday are not in shape as yet to announce. Tuesday evening the annual banquet will be held at Barney's. Wednesday's arrangements will be announced later.

A campaign is being carried on having as its purpose the breaking of all attendance records at National Association of Talking Machine Jobbers meetings. The officers figure that the increase in the talking machine business in the last twelve months alone has been something tremendous with every member, and are hoping to prevail upon the heads of all jobbing houses to attend the meeting along with their department managers. In hopes of getting these gentlemen to attend, a strong appeal is being made to them.

A distinct feature of this year's convention is going to be the presence of all the Victor officials as well as their department managers and superintendents. The Victor people propose to give actual demonstration of different departments of their work and their product at Atlantic City on the 7th. Nothing of this nature has ever been attempted before. It is safe to say that every jobber who attends will see things which he has seldom seen—even at the factory. The Victor Co. is anxious to have the heads of the Victor jobbing firms present at the 1914 meeting of the association, as it is going to considerable trouble and expense to put on this educational stunt.

Naturally the annual banquet will occupy a prominent place on the program. It will be held Tuesday evening the 7th, at "Barney's." James F. Bowers, of Lyon & Healy, will be toastmaster. Excellent speaking, a fine orchestra and a cabaret show are already assured to instruct and amuse the banqueters. Hon. Walter I. McCoy, Congressman from the Ninth New Jersey District, has been obtained as one of the principal speakers, and will deliver an address on "Unfair Competition."

Louis F. Geissler, general manager of the Victor Talking Machine Co., and Edward Lyman Bill, editor The Talking Machine World, will be heard from.

PRAISES DANCE RECORDS.

The St. Louis, Mo., branch of the Columbia Graphophone Co. received last week an interesting letter of endorsement from W. T. Clark, 3806 Oliver street, that city, proprietor of the Westminster Dancing Academy, one of the best known exponents of the modern dances in St. Louis. This letter reads as follows:

"Our experience with the Columbia dance records has proven more than satisfactory. We have used them daily in our studio this season for private dancing lessons and find them unsurpassed in music, time, durability and also saving the expense of a musician. They are without doubt the modern musician of the day, and I gladly recommend them to our patrons. Very truly yours,
(Signed) William T. Clark."

Every talking machine sold without an Automatic Stop means lost profit to the dealer, distributor and manufacturer. Are you treating the trade right?

The simplest to attach; the most accurate; the one giving you the largest profit is the

STANDARD AUTOMATIC STOP

Nickel Finish, \$2.00

Gold Finish, \$3.00

We are the pioneer inventors and manufacturers of Automatic Stops. Send 25 cents in stamps for a sample. Write on your business letter-head only. Place regular orders through your jobber.

STANDARD GRAMAPHONE APPLIANCE CO.

173 LAFAYETTE STREET,

NEW YORK

THE TRADE IN BOSTON AND NEW ENGLAND

JOHN H. WILSON, MANAGER, 324 WASHINGTON STREET, BOSTON, MASS.

(Special to The Talking Machine World.)

BOSTON, MASS., June 6.—May certainly has been the dance month in Boston, for with dancing exhibitions at two theaters and one large hall there have been crowds of people given a new interest in the latest movements. Besides this one large concern in co-operation with a leading daily paper spread a wide knowledge of the hesitation, tango, one-step, etc., throughout New England, and this has helped the sale of dance records. Many of the local houses are getting ready to supply outfits for summer cottages at mountain and seashore, and this has helped to increase the volume of business most perceptibly.

Enlarging Chickerling Victor Rooms.

The Victor warerooms of Chickering & Sons, 169 Tremont street, show constant evidences of popularity, and Manager W. W. Longfellow is finding business good for this season of the year. He will not be able to get away on his vacation quite as early this year as he otherwise might like, as he must be on hand to superintend some improvements that are to be made in a few weeks. These include an enlargement of the quarters on the second floor by taking a large middle room which just now is used for a piano wareroom. This will give the Victor department just double the capacity, but it is figured that this space will be used to good advantage, as the business is increasing rapidly under Manager Longfellow.

Donates Fifty-eight Prize Cups.

The Boston dancing contest at the Boston Theater, in which a number of well-known exponents of the new dances took part, was a marked success and large audiences were the rule at every performance for an entire week. The Eastern Talking Machine Co. was especially interested in the contest, as in all it offered fifty-eight cups as trophies, fifty-six of which were small ones, and two large ones for final competition on Saturday night. "Billy" Fitzgerald, of the Eastern Co., was especially active in the success of the week's exhibition, and he had installed on the stage an Auxetophone, which was used for the dances in which the amateurs took part. Throughout the week fully 10,000 copies of the book of modern dances issued by the Victor Co. were distributed.

W. J. Fitzgerald Promoted.

Speaking of the Eastern Talking Machine Co., it is pleasant to note the fact that W. J. Fitzgerald—Billy to all his friends—has been raised to the responsible post of wholesale manager for the

Eastern Co. Billy is a capable man, has had considerable varied experience in the talking machine business and has been especially prominent in introducing the machines into the schools in and around Boston. Any promotion that comes to this popular man in the trade will be welcomed by his many friends, as he has a large following throughout the trade.

Enters Supply Business.

A. W. Chamberlain, who formerly was wholesale manager of the Eastern Co., and who resigned a couple of months ago, has established himself at 120 Boylston street, where he makes a specialty of talking machine supplies. Mr. Chamberlain is the inventor of a safety needle device that is well spoken of by those who have tried it, and this he will make a special feature of.

Dance Carnival a Success.

On the afternoon and evening of May 14 there was a dancing carnival in Mechanics' Hall under the personal direction of G. Hepburn Wilson, M.B., who is the supervisor of dance music for the Columbia Co. He was assisted by Paul Swan and teachers and pupils from Mr. Wilson's seven dancing studios in New York. The music was furnished by the entire dance orchestra of the Columbia Graphophone Co., which came over to Boston especially for this carnival. The program was a long and varied one, and was heartily enjoyed by two audiences.

New Victor Warerooms Completed.

Now that the Victor department of the C. C. Harvey Co. is permanently established on the second floor of this concern's large warerooms at 144 Boylston street, Francis T. White is better able than ever before to meet the needs of his customers. The quarters pleasantly overlook Boston Common and are comfortably furnished and fully equipped with various styles of Victors and a large assortment of records to suit all tastes.

Returns After Six Months' Trip.

"Billy" Ellsler, who has been away from the Columbia Co. on a six months' leave of absence, during which he was manager for Holbrook Blynn, the theatrical star, is back at his post of floor manager, and the trade is glad to welcome him again. Two other new men with the Columbia Co. are S. B. Bowman and A. G. Haskell, both salesmen in the retail department.

Record Sales to Theatrical Folk.

Sallie Fisher, the comedienne, and her husband, Arthur Houghton, who is manager for Montgom-

ery and Stone, the stars of the theatrical world, were recent callers at the Eastern Co.'s warerooms, and left a large order for records to be sent to their summer place, Fisher Camp, Songo Lock, Lake Sabago, Maine.

Moving to Summer Home.

Manager Arthur Erisman, of the Columbia Co., and family, have planned to spend the summer on the Shore drive at Lynn, and will move there from the Cambridge within a fortnight.

Visits New England Dealers.

Manager Royer, of the Victor department of the M. Steinert & Sons Co., has lately been making a tour of the Southern New England agencies. He reports quite a good demand for goods for the uses of summer cottagers and he has mapped out an extensive summer campaign program on which his sales force will shortly embark. Mr. Royer expects to go to the Atlantic City convention of talking machine men.

Opening for Successful Manager.

Although Henry Rosen, of School street, has had his Back Bay talking machine store open several weeks and is doing a good business there he has thus far been unable to find just the right man to manage the establishment. This despite the fact that he has advertised for an experienced salesman and one that possesses initiative. Mr. Rosen is planning to take a trip to Chicago and other Western places this summer, a trip that he has wanted to start upon several times before. On the trip he will make a careful study of ways and means as they pertain to the talking machine business.

Splendid Record Business.

Manager Batchelder, of the Victor department of the Henry F. Miller Co., finds his customers busily engaged these days making a careful selection of records for use during their summer recreation at the shore or country cottages. One of his good customers for many weeks past has been D. C. Jennings, of the "Under Cover" company, playing at the Plymouth Theater, who runs in every few days. This piece has been running for twenty-four weeks thus far, so Mr. Jennings feels like a regular Bostonian. A large shipment of records was made lately to Peru, where a Miller customer is making an extended visit.

New Columbia Representatives.

Manager Erisman has closed contracts with several large houses for the handling of Columbia goods, which should considerably add to the out-

GO WHERE you will and there is only one universal opinion to the Edison Diamond Disc Phonograph—that it is an almost human means of producing human music. It is this feature that so appeals to music lovers.

Those who are Edison men now are building a business on the foundation of satisfaction, and there is no limit to their profits.

If you sell the Edison, you will have the same opportunity. We will help you with our organization, too.

The
Pardee-Ellenberger Co.
BOSTON, MASS.

**Real Music
At Last**

The
Pardee-Ellenberger Co.
NEW HAVEN, CONN.

THE TRADE IN BOSTON AND NEW ENGLAND

JOHN H. WILSON, MANAGER, 324 WASHINGTON STREET, BOSTON, MASS.

put. Among these are Kennedy & McInnis, of Pittsfield, which is a large concern of Western Massachusetts; Mason Bros., of Bellows Falls, and the Household Supply Co., of Rutland, Vt., which is one of the leading houses of the Green Mountain State.

Close Successful Year.

The Eastern Talking Machine Co. has just closed a most successful school year and much of the credit belongs to "Ed" Welch, who has labored long and hard to popularize the Victor outfits with institutions of learning in Boston and the suburbs.

Imperial Phonograph Co. Opens.

The Imperial Phonograph Co. is the name of a new concern which is now open for business in Boston. The company has established offices at 9 Doane street, in the downtown section of the city, where it has a suite of offices on the third floor. The president of the company is O. B. Cole and Charles F. Simes is the sales manager, and the latter now is engaged in assembling his field force. The machines and records are being manufactured in the city, and already the first invoice is ready for the trade.

Columbia Used at Harvard.

The Columbia Grafonola is being used with much success at Harvard in the teaching of the German language. The pronunciation of the Teutonic speech has been difficult for some of the students and so the head of one of the German courses has fallen back upon a machine to help him out. German folksongs have been used considerably for the desired purpose, as the accent is thus given to a musical accompaniment.

Looking Forward to the Convention.

Henry Winkelman, of the Victor department of the Oliver Ditson Co., is looking forward to his trip to Atlantic City on the occasion of the annual convention early in July. Likewise he is planning for his summer vacation, which he will embark upon soon after his return home.

A LUBRICANT TO TRADE.

How Men in All Trades Are Waking Up to the Necessity of Publicity.

Ability of a high order is required to successfully conduct manufacturing and retail establishments. It is one thing to create and another to successfully market. Each function is interdependent, and both are of prime importance. The sales manager or the executive must be well grounded in the principles of advertising even if the details of that department are entrusted to a manager.

It is advertising which acts as a great lubricant to business, whether it be wholesaling or retailing. Talking machine men are understanding this great necessity more and more. It is true that some of them still deserve to be awakened, but the great majority of them have become alive to the fact that their business cannot survive unless they use up-to-date methods of publicity.

Everyone is an advertiser to-day. The only man who does not advertise is a "dead one." Advertising means making known, and practically every word or act in this world is an advertisement. We give up our seats in a car to ladies to advertise that we are gentlemen. We attend the opera to advertise that we are cultured. We keep out of jail to advertise that we are honest. The man who stands pat on four hearts tries to advertise that he has a flush. If he is called, it is not the fault of the advertising, but due to the fact that he failed to observe the cardinal law of business, "have goods to back your advertising." Each year makes a terrible loss in the ranks of the once mighty host whose battle cry is "My business is different; it can't be advertised." The banks, doctors, schools and public service corporations have surrendered. Everyone is an advertiser. The only one who isn't is a dead man. Whether one's advertising is a success or not depends upon methods. The word

advertising has been localized until it has come to mean the art of making known certain facts for the purpose of inducing certain people to follow a specified course of action. It makes no difference whether one is trying to make a man buy a certain make of "talker," or make a woman get off a car the right way, the method by which it is made known is an advertising campaign.

The purpose of an advertisement is to sell goods. Newspaper space is too expensive a medium to be used for the exploitation of the writer's wit or cleverness. The ad writer who constantly bears this purpose in mind will produce effective ads despite faults of grammatical construction or display. When the simplicity of purpose of an ad is realized, it will be seen that its preparation is merely a matter of salesmanship. The duties of the ad writer and the salesman are identical and their methods should be the same. Every salesman should have a well defined system of approaching, interesting and selling goods to a customer, and the principles of this system can be applied equally well to an advertisement. Any successful salesman who is capable of analyzing his system of selling goods, who can tell just how and why he induced the customer to buy, is also capable of constructing an advertisement if he applies the principles of his salesmanship to his advertisement.

BUSINESS BEST IN SMALL TOWNS.

Salesmen who cover the smaller cities and towns of the country have no reason to envy their brethren who take in the larger ones. According to one of the prominent local manufacturers fully seventy per cent. of the present business is coming from cities and towns under 75,000 population. The reason for this, it appears, is that stocks are not so heavy in the smaller centers of the country because of the more limited purchasing power, and that these stocks are consequently turned so frequently that the small buyer is ready to take on new merchandise in fair quantities at almost any time. The fact that the buyers for the smaller stores are as a rule not hampered by the supervision of a merchandise man is also cited as a reason for the small center's better buying. While these men are said to make for a better and safer system of merchandising, they are sometimes responsible for the buyer's losing some

specially attractive offerings because his or her appropriation has been temporarily exhausted. From the present condition of business in most lines, the opinion is advanced that many appropriations are exhausted at the moment.

OCCUPYING HANDSOME QUARTERS.

Pardee-Ellenberger Co. Located in New Home, Which Is Up-to-Date in Every Detail—Immense Floor Space at Company's Disposal.

(Special to The Talking Machine World.)

BOSTON, MASS., June 9.—The Pardee-Ellenberger Co. is now comfortably located in its new quarters at 26 Oliver street, and handsomer warerooms it would be hard to find. The main quarters are on the ground floor, and the whole interior is finished in Circassian walnut of handsome grain. The clerical office occupies a large part of the Oliver street front, and the clerks can work under the best possible conditions, and there is an abundance of daylight. All the furniture is brand new, even the large safe. Off this apartment is Manager Silliman's private office, and he too has an entirely new equipment of office furnishings. Directly at the rear is the main show room, off of which is a smaller room, where dealers can take customers privately and give a demonstration of the Edison disc machine. The main show room, like the rest of the floor, is finished in Circassian walnut, and a large, handsome rug covers most of the floor. All about the sides are the various types of Edison machines. All the ceilings are of the metal type, and the artificial lighting is by the indirect electric system. The shipping room occupies the entire rear half of the floor, and looks out into an alley, where the wagons can take on their goods to be shipped with very little handling. This shipping room is unusually large. The head man of the shipping room has a private office, and beside it is a good-sized repair shop, fully equipped to meet all emergencies. One entire side of the shipping room is given over to record racks, filled with thousands of discs and cylinders. In addition to this enormous ground floor space, the Pardee-Ellenberger Co. has still another floor for storage purposes. Thus is the company now in a better position than ever to meet the requirements of its growing trade, which covers entire New England.

An almost railroad schedule of deliveries of Bagshaw-made Needles

IN OPERATING a needle manufacturing business the size of ours, it is absolutely necessary to follow certain well-defined lines as regards deliveries, for we recognize the importance of filling the requirements of our customers as needed. So you can be sure that an order placed with us for so many millions of needles monthly for a year will be shipped promptly.

We wish to make this statement now as to shipments, for this is an important link to the Bagshaw service.

Established 1870
Pioneer
Needle Makers

W. H. BAGSHAW
Lowell, Mass.

Jobbers: "On To Atlantic City"

¶ This year the Mecca for Victor jobbers will be Atlantic City the 6th and 7th of July.

¶ Object: The eighth annual convention of the National Association of Talking Machine Jobbers.

¶ "'Taint always the biggest Rooster that has the most sand in his crop."

¶ This convention isn't as large as some others, but—

¶ If you are the head of a Victor jobbing business, you preferably—or at least one representing you—or better, both, ought to be there to learn what the foremost men in the Victor business are thinking, saying, doing.

¶ These conventions are full of Optimism, Good-cheer and Inspiration; you are welcome to bring along all the ideas you have and to take home more than you bring. If you are an optimist, you will want to come; if you are a pessimist you certainly need to.

¶ There will be talks by able men. Daily discussions. Friendly arguments. Ideas galore. You may have had the ideas yourself but mislaid them somewhere.

¶ You surely don't want to miss this chance to meet or renew acquaintances with the worth-while people in your line of business. It is a duty you mustn't neglect.

¶ For your entertainment an arrangement committee has been working faithfully for months, and it has up its sleeve several innovations which it is claimed will make even the regular attendants sit up and take nourishment. Some of these will be announced shortly, while others are said to be too good to announce, but must actually be seen to be appreciated.

¶ It isn't too early now to talk it over with the city ticket office and reserve accommodations to the "Playground of America" for Saturday, July 4; earlier if needs be.

¶ The Association officials are going to handle all the business in one big day—and Tuesday will be devoted to the usual open meeting, at which Victor officials will talk and listen.

¶ Even though you do not admit it, you need the "change"; besides think of those delightful daily dips in the briny.

¶ Of course you are busy, but come to Atlantic City and forget it.

¶ Just communicate with L. C. Wiswell, care of Lyon & Healy, chairman of the arrangement committee, and say "count on me."

LANDAY BROS. NEW FIFTH AVENUE STORE.

The Latest Addition to the Landay Victor Establishments, at 427 Fifth Avenue, is Most Palatially Equipped and Superbly Furnished to Meet the Demands of the Clientele of This Firm—Description and Illustrations Will Give Idea of Its Completeness.

The accompanying illustrations showing the exterior and interior of the new Landay Bros. store at 427 Fifth Avenue, New York, will give a fair idea of the attractiveness of this latest addition to the chain of Landay Victor establishments. This store,

the booths and furniture and the total absence of the "cramped" atmosphere which is frequently found in high grade specialty stores. A cozy corner near the right hand side of the entrance enhances this feeling of good cheer and comfort.

The illustration depicting the exterior view of the new Landay store is especially worthy of attention as representing one of the finest pictures of this kind that has ever been produced. This photograph is a faithful and accurate view of the appearance of the store at



View Upon Entering New Landay Store.

which was recently opened, is one of the show places of the local Victor trade and has won the admiration of business men all along Fifth Avenue.

Located between Thirty-eighth and Thirty-ninth streets, in the heart of Piano Row, and directly opposite the new home of Lord & Taylor, this store has been furnished throughout in a quiet, subdued tone, entirely in keeping with the character of its surroundings. Eleven demonstration rooms, larger than most rooms of this nature, are placed along the main and mezzanine floors, all furnished with a view of offering customers and visitors every com-

night time, the picture having been taken at 1 o'clock in the morning.

The favorable impression that this new Landay establishment has created is well summed up in the following letter sent Landay Bros. last month by the Fifth Avenue Association, one of the most influential organizations of its kind in



Looking Towards Fifth Avenue from Center of Store.

fort and convenience. These rooms are finished in typical French style, the color design being a gray and green, delicately blending to harmonize with the other decorations.

Upon entering the store the visitor is immediately impressed with the spacious arrangement of

jectionable, and, after all, we are all working together for a common object, the preservation of this great thoroughfare as an asset for high-class business. Yours very truly, (Signed) Robert Grier Cooke, President."

Roy Forbes, connected with Landay Bros. for

several years, is manager of the store at 427 Fifth Avenue and, assisted by a capable corps of sales people, has already laid the foundation for an extensive clientele among Fifth Avenue's shoppers and music lovers.

FORM A PERMANENT ASSOCIATION.

Committee of Retailers of New York Brought Together in Support of the Stevens Bill Will Prove a Permanent Body and Extend Its Activities in a Mutual, Protective Sense.

The committee of retail merchants of New York and vicinity which attended the big mass meeting held recently at Aeolian Hall under the auspices of the American Fair Trade League for the purpose of supporting the Stevens bill for price maintenance, has taken the form of a permanent organization and will branch out in its efforts to aid retail merchants.

The temporary committee held another meeting later and decided to proceed with a permanent organization, to embrace any retail organiza-



427 Fifth Avenue, Night View of Landay Bros.' Store.

any city of the country:

"On behalf of my associates, as well as myself, I hope you will allow me to extend to you my congratulations upon the exceedingly attractive place which you have at Thirty-eighth street and Fifth Avenue. The general layout and the details you have worked out are most alluring. In fact, I should think it would be very difficult for anyone, musically inclined, to pass your place without going inside.

"You see we are just as ready to give due credit for things that we believe deserve it as we are to criticize what we consider ob-

jections which may desire to affiliate with it. Already something like twelve associations in and around New York City are enrolled and plans are to be made for adopting a constitution and by-laws and superseding the temporary officers, who will serve in their respective capacities till their successors are elected.

It is planned to make the committee a conference, composed of probably three delegates from each affiliated body and a certain number of outside independent members not connected with definite bodies; to open permanent offices and to be supported by a per capita tax on the several affiliated associations. The committee on by-laws comprises the following: William G. Anderson (pharmaceutical conference), John H. Steeneck (retail grocers), John G. Bremner (talking machine dealers), J. H. Booze (photographic trade), J. M. Kohlmeier (hardware and supply dealers) and Nicholas Ehrlich (retail tobacconists).

TO HANDLE COLUMBIA LINE.

E. L. Ward, Oneonta, N. Y., has completed arrangements to handle the Columbia Graphophone Co.'s line. Mr. Ward is planning to institute an energetic campaign for Columbia products, making a special effort to promote dance record business.

ORDERING IN ADVANCE VS. HURRY-UP ORDERS

Discussed in a Most Interesting and Illuminating Way by H. G. Stanton, Vice-President and General Manager of the R. S. Williams & Sons Co., Ltd., Toronto, Can., in Edison Phonograph Monthly—Has Had Long Experience as Jobber and Is Popular.

The importance of a plan that will insure delivery of goods when most desired is unfortunately overlooked by many dealers, for lack of that one successful element in business—looking ahead. So many merchants form the habit of leaving everything to the last minute instead of anticipating the future as far ahead as they can, laying their plans out to meet it successfully, and thus be always ready. Many dealers have no conception of how the step in anticipating their wants or planning ahead will simplify matters for them, increase their business, increase their profits, and relieve the worry, confusion and loss which follow inevitably as a result of "scrambling." Lack of preparation, confined specifically to placing of advance orders, is usually the result of lack of capital, resulting in fear of being overstocked and unable to meet obligations; lack of confidence in the goods you are selling, and the ability of your organization to sell them, or lack of ordinary business observation covering local trade conditions. Any man in business, with ordinary business prudence, should be able to estimate with reasonable exactness how many machines and how many records he will sell six months in advance, and still more exactly what his sales will be for three months in advance. Many dealers, however, give this phase of the business no consideration, because of the service they get and because they meet their requirements with reasonable satisfaction. As a result of this, when the heavy fall and Christmas season approaches, the habit of placing orders only as actually required is formed, and the thought of anticipating requirements for fall and Christmas is not taken seriously by them. As a consequence of this, there is what might be termed a "jam," to the jobber, to the manufacturer, to the transportation companies and to themselves, which results in aggravating delays, serious loss of business and an unknown but undoubtedly serious loss of future patronage.

We contend that anywhere from 75 to 95 per cent. of this trouble can be eliminated by the placing of advance orders. This can be done by every dealer, and instead of placing an order for what he will be requiring to-day or to-morrow, place one order now for what he may want for immediate shipments, another order for what he may want for shipment on the first of next month, and another order for what he may want on the first of the second month, and so on, as far ahead as local conditions may warrant; this depending, of course, largely upon his distance from source of supply, transportation facilities, etc. The only problem that presents itself in ordering in advance (and this is a slight one) is that of properly recording orders placed, so that if they are to be added to or in any way altered, it can be done without confusion either to the dealer or the jobber. If orders are placed ahead, and then for want of some system are not recorded, but left to memory, and later on the order duplicated, confusion will, of course, follow; but by having a card system or a book so arranged that each type of machine is represented, and on the page so headed, the number of machines on order, the whole proposition is simplified and results in having improved business and many other benefits to the satisfaction of all.

CARD SHOWING ORDERS.

Type.	Amberola V.	\$100.00 Style.		
In Stock.	Order.	Date.	Rec'd.	Date.
			3	May 19
3	10	Aug. 1-14	7	May 28
4	6	Sept. 1-14	6	June 10
3	25	Oct. 1-14		For shipment
			13	rush
			12	Nov. 1, 1914.

To permit of our travelers co-operating with our dealers, in placing advance orders, we furnish our representatives each week with a record showing the amount of monthly business done by each dealer in the town visited. With this knowledge brought to the dealer's attention, it is a simple

matter to show him that his business should run 10 or 20 per cent. ahead of the previous year (or whatever percentage of increase or decrease trade conditions in their judgment, warrants) and ordering a proportionately greater or lesser amount than was done in the same month of the previous year. Even if this is carried out in the most conservative manner possible, and orders placed for one, two or three months ahead (and at distant points, four months ahead) and dealer subsequently requested to add as much again to each month's order, there is a decided gain; even if, finally his advance order is for only one-half, that assists us materially. We are sure every dealer will appreciate these facts if brought home to him by his jobber; the only condition which works against it is lack of system. Therefore, we think if a card system, such as herein shown, were adopted it would relieve the situation materially, and it would be appreciated by jobber, dealer and the public.

If the same plan were followed in connection with records—standing orders for so many each of new issues, so many each of any special issues, the same convenience would apply to these.

This problem has been such a serious one with phonograph dealers for so many years, we believe the situation can best be met by each jobber reaching his trade frequently and persistently throughout the months of August and September, so that when his traveler calls during September and October, material increase in "advance orders" would be made; and if a little improvement is made this year and developed along still better lines next, undoubtedly conditions will improve to the advantage of all.

The above conditions would apply to every dealer, whether he is the exclusive Edison dealer in his town or has numerous competitors; but where there are competitors, certainly the necessity for placing advance orders will be even greater than where there is a limited or no competition. Why one dealer will permit his competitor to excel him in the matter of service when it is so simple to anticipate wants thirty or sixty days ahead, we cannot account for, unless it is that the neglectful dealer deliberately tries to help his opponent, for we know of few better ways of doing this than to be out of stock of popular selling types of machines or records when you competitor has them.

The placing of advance orders for new issue records is of such vital importance to the development of the trade that we think it should be the dealer's first duty after the establishing of a dealership.

The regular dealers' order sheet for new issue records, sent direct from the factory, and the forms generally used by dealers in placing their advance orders for new issue records are undoubtedly good ones, but we have found that dealers sometimes mislay or neglect to place their advance orders, so that in addition to the form referred to from the factory, we have a special postcard bearing our address on one side and on the reverse the following,

"Kindly enter my order for each of the new issue records until I notify you to discontinue,"

which we send to each of our Edison dealers, accompanied by a letter, drawing his attention to the advisability of becoming acquainted with the new records that are being issued each month. It permits of his more intelligently ordering for his regular stock requirements, and at the same time to permit his customers to know that on a certain day or evening of each month they can hear the entire list of new issue records, all of which means better service, better satisfaction to his patrons and more business for him.

When the cards are returned to us we place a standing order on our files for the quantity of records mentioned. These records are sent out on the date of shipment, but in the meantime should we receive one of the order blanks from the same dealer (who overlooked he had placed a standing



NYOIL

For polishing varnished woodwork it is extremely satisfactory. No oil is so clean.

Ask your watch repairer whose oil he uses on your watch.

order with us for one or two or three of each record each month) we would take his order blank, but not increase his order beyond his standing order if it was for just two records. But where he ordered four or six or ten, we would send this quantity. In any event, by his returning the postcard placing a standing order with us for one or more of each record, he would be assured of receiving the quantity specified promptly on the new issue dates.

Where advance orders cannot be obtained and the jobber has to depend upon "hurry up" service, it is necessary, of course, that the jobber anticipate his own wants. Sufficient stock room space in which to conveniently arrange records for the quick filling of orders, and an efficient staff of order clerks and shippers must be kept available; but it is hard to accomplish all this without some check upon service and despatch. To obtain this we have a time stamp with which every order received is not only dated, but timed as to the minute of arrival. The order of "write off" to the department is also so dated and timed, and the schedule of the department provides that every order received in his department up to 2 p. m. must be shipped that day if a freight order, and up to 4.30 p. m. if an express order, and there must be some very good reason for deviation from this schedule.

Many dealers wire orders or indicate a special necessity for their being rushed, in which case special attention is given them from the time they are received until the time they leave our shipping room. They are, in other words, given express service. They are specially marked when written off, they are specially followed through by the senior clerk of the department, and they are specially marked when they reach the shipping room, so that if they reach that department after the hours above specified, they are given special attention. In this way we try to serve our urgent dealers in the most efficient manner possible.

There are, of course, frequent delays from causes beyond our control; and, no matter how efficient the service, there cannot be the same convenience and assurance with rush orders as there are with advance orders, to say nothing of the big saving between freight and express charges.

If the card system was adopted more than half the worry during the fall and Christmas season will be turned into pleasure.

THE SECRET OF TRUE SOUND.

"The Secret of True Sound" is the name of a card issued by the Little One-Der Co. featuring the correct color value of sound and incidentally claims about the merit of the Little One-Der, which is an attachment for talking machines. A. S. B. Little, the inventor and manufacturer, reports that this Little One-Der is selling rapidly all over the country, and the outlook for it is very encouraging, particularly for the fact that it sells wherever practically introduced.



The decease of Mme Nordica has created an increased demand for her records. If you don't carry them, you lose.



(Write for "Music Money," a book "full of meat" for those dealers interested in quick and frequent turnover of capital.)

Columbia Graphophone Company
Woolworth Building, New York

NO OCCASION FOR PESSIMISM IN CLEVELAND.

Talking Machine Business Seems to be Exempt from Many of the Complaints Which Attach Itself to Other Lines of Trade—Talking of a Victor Dealers' Association in Cleveland—Grafonola Co.'s Handsome Quarters—What Run Around the Trade Reveals.

(Special to The Talking Machine World.)

CLEVELAND, O., June 8.—The talking machine dealers of Cleveland are doing nicely, and during the month of May the general business transacted was of large proportions. Notwithstanding the times seem to be out of joint, money appears to be plentiful with all classes, and sales of machines, of the various types, from the cheapest to the most costly, are in daily evidence. The following reports of the various dealers clearly demonstrate that there is no occasion for pessimism in the talking machine trade.

J. Laurie, auditor of the Columbia Graphophone Co., spent several days at the local office the first of the month. He expressed himself pleased with the condition of the company's business in this locality.

W. J. Roberts, Jr., practically the pioneer in the talking machine business in Cleveland, and who recently retired from the Buescher Co., has, following in the footsteps of several other talking machine men, engaged in the automobile business. He has hundreds of "talking" friends who wish him success.

H. E. McMillin, Jr., vice-president and general manager of the McMillin Co., who was absent from his office for several days, owing to illness, is back at his desk, having fully recovered.

A. O. Peterson, manager of the Cincinnati branch of the Phonograph Co., spent a few days in the city recently, enjoying a visit with his many friends here. He is highly pleased with the success he is meeting with in that city.

The Cleveland Victor dealers, of which there are a large number in the city, are agitating the formation of a talking machine association. A number have already signified their intention of becoming members.

The summer season has opened up auspiciously with the Eclipse Musical Co., especially in the educational line, as it has sold quite a few school machines recently. Mr. Lane and Mr. Dinslow, of the company, have both had years of personal, practical experience, and know how to handle Victrola prospects with tact and skill. They have jointly started on a follow-up campaign, in the way of a canvass, and within two weeks nineteen machines and several hundred records were sold.

L. N. Bloom, secretary of the Phonograph Co., says business for the month of May was very good. Reports, he said, from dealers locally, and throughout the State, indicated that the sale of Edison machines and records was as brisk as ever.

Owing to the peculiar business conditions generally, the warm weather and building operations going on in enlarging and remodeling the store, business, said W. J. Davies, manager of the talking machine department of the Wm. Taylor Son & Co., is slowing down. This company, however, is doing a very fair business.

Manager Madson, of the local Columbia store, is

highly pleased with the new location, and the increasing volume of business, which he says is way ahead of last month. The demand for the Leader and the Mignonette types of machines was said to be especially good. One of the last piano houses in the Cleveland territory, that were not handling talking machines, has just taken on a complete line of the Columbia goods, handling them exclusively.

At the talking machine department of the Bailey Co., business is reported very good in the machine line, with a large record trade. The larger call at present was said to be for the smaller type of machines and for dance records, for the summer resorts and boating parties.

The Grafonola Co. of Cleveland, who fell heir to the old location of the Columbia Graphophone

TRADE CONDITIONS IN BALTIMORE

Have Been Very Satisfactory During May and Early June—Large Suburban Business Being Done Owing to the Movement of Citizens to the Country—All the Leading Makes of Machines Are in Active Demand.

(Special to The Talking Machine World.)

BALTIMORE, MD., June 5.—The talking machine situation in this section has kept up in its usual good shape during May, and the dealers feel that they will be able to make just as satisfactory reports for the present month. Thus far the business for June has been very desirable and the dealers predict that it will continue right on through the summer.

The dealers have received a number of orders for suburban homes and from those persons who spend the summer in the mountains or at some of the watering shores. These instruments at such places are very popular, especially at night, when the young folks gather for an impromptu dance.

Reports show that the Victrolas and Columbias are becoming a great fad with the dancers and these machines are used at times in preference to some other musical instruments because they give good time and keep the dancers in their proper stride all through the time that they are on the floor.

H. R. Eisenbrandt Sons, who are among the regular distributors for the Victor line, report an excellent May, and have reasons to believe that the good things will continue indefinitely.

Manager W. C. Roberts, of E. F. Droop & Sons Co., says that he has no reason to change his usual statement with regard to the business done by his firm with the Victors and Edisons. He says that sales have gone along in fine shape all during May, and the prospects on hand are a good indication that his sales force will be kept busy all during the warm weather in an effort to reduce these prospects to real sales.

Co., at 913 Euclid avenue, is prospering beyond all expectations. Mr. Routh, manager, said: "Business is on the increase, and even though some other dealers are complaining. If the business of the Grafonola Co. continues increasing at the present rate, we will not have room next fall to take care of our trade."

The Buescher & Sons Co. report business moving along prosperously, and that daily sales are being made of the various types of Victor machines, with a good record trade. The June list was said to be popular and taking especially well.

"The Victrola business of the McMillin Co.," said Mr. Kellogg, "has shown a marked increase over that of any previous year. The sales show a demand for the higher priced instruments, a number of \$200 Victrolas having been sold during the past months. The noticeably increased demand for the more expensive machines is owing to the fact that the dance craze has taken the whole country by storm, and the larger Victrolas are more popular and suitable for dancing purposes, especially for the summer hotels and country homes."

Manager F. A. Dennison, of the local branch of the Columbia Graphophone Co., talks in the same enthusiastic strain as his fellow dealers. Mr. Dennison declares that May was a great month, and that prospects for the future were as bright as they could ever expect to be.

Joe Fink, head of the Fink Talking Machine Co., has similar words of cheer to say with regard to the business he has done during May with the Victor and Columbia lines.

Albert Bowden, who is head of the sales force for Sanders & Stayman Co., Inc., states that it gives him great pleasure to be able to say that the talking machine business is in such excellent shape and this alone will help to make him enjoy his two months' trip in Germany. Mr. Bowden will sail on June 24 for his home in Cologne, where he will visit his parents. Mr. Bowden has not been to his home for twenty-five years, and looks forward to his trip with a great deal of enthusiasm. Mr. Bowden is booked to sail from Germany for America in the latter part of August.

WINNERS OF VICTOR PRIZES.

Those Who Secured Awards in Record Describing Contest and the Records They Selected.

The prize winners in the contest announced a short while since in the "Voice of the Victor" for the three best descriptions of Victor records are the following: First prize, Robert Walsh, Rudolph Wurlitzer Co., Cincinnati, O.; second prize, Miss Besse Patterson, with Frank L. Young, Mount Vernon, O.; third prize, Miss Bertha Moselle, Arison's Music Store, New York, N. Y.

Mr. Walsh described the selection "From the Land of the Sky Blue Water;" Miss Patterson discussed "Erlkoenig," and Miss Moselle described the "Monologo from Hamlet."

Perhaps the man who is looking for trouble is better prepared to dodge it when it comes,

An Amazing Sale of the World's Greatest Machines



Style No. 25

The Keen-o-phone—most marvelous producer the age has known and the absolute masterpiece of all talking machines—offered the trade at give-away prices for quick clearance.

There are very few dealers who are not familiar with the wonder of the Keen-o-phone—how the inventor, after realizing his ideal of the world's perfect talking machine, lost out because he failed to realize that "making" is one thing and "creating a market" another; how the factory went on turning out these superb instruments with no real market developed. When the crash came shrewd dealers snapped up most of the surplus, but there are still about

2000 of these machines left and offered to you at a discount of 70%, which means:

We can supply this machine with same style top as No. 20 if desired.

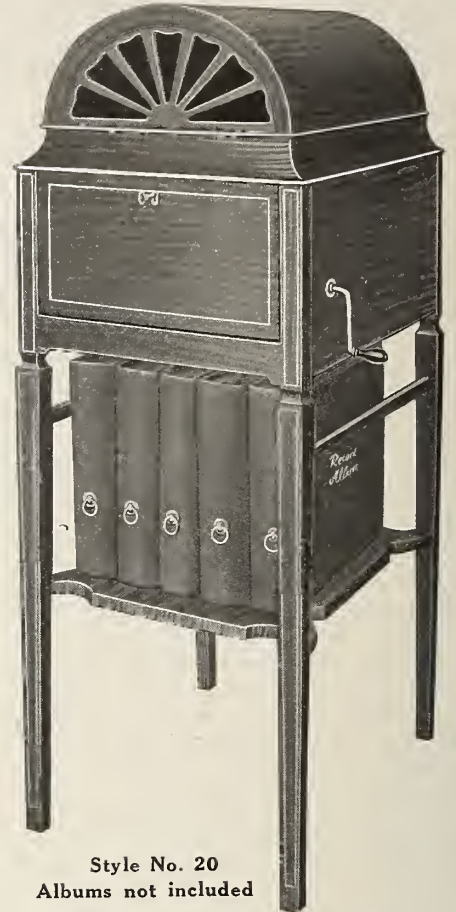

Style No. 20
Albums not included

\$100,000 Worth of Machines for \$30,000

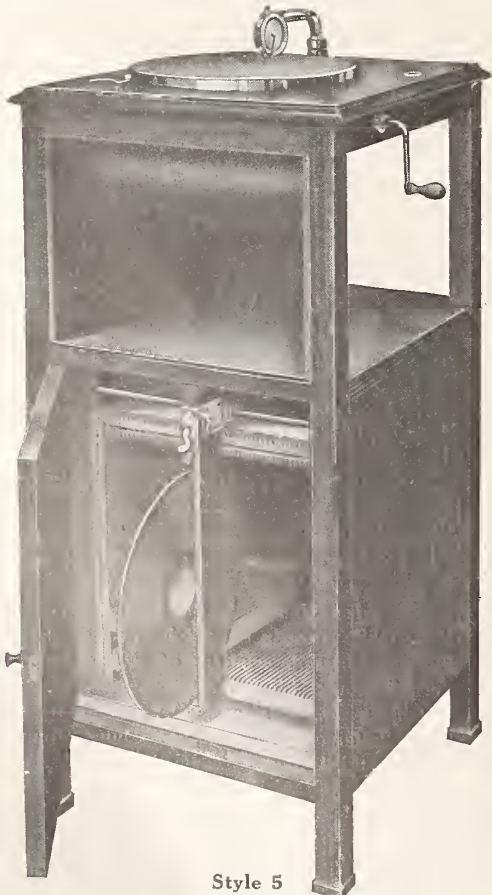

Style 5
Containing a Famous Filing Device

Read the High Lights on this Remarkable Machine

- ☐ *The Keen-o-phone will play any Disc record made.*
- ☐ *Its patented features eliminate all scratching, rasping and all foreign noises of any kind.*
- ☐ *This silvery clearness and purity of tone in itself marks the Keen-o-phone's decisive supremacy over all other machines.*
- ☐ *All the cabinet work was designed and made by Pooley—evidence enough that these are among the most artistic finely finished oak, mahogany and Circassian walnut cabinets built.*

There are five styles left—more of some than others. Several styles are equipped with the famous Pooley Filing Device. And remember! all are perfect high-grade machines—and cannot last long. Hurry your reservation to-day! Reserve *the first time* as many as you can use, or write quick for appointment at address below, or for any information wanted.

Address all inquiries to

E. BAUER, Special Selling Agent
214-218 So. 12th Street
PHILADELPHIA, PA.

IN DOLLARS AND CENTS:			
\$175	Keen-o-phones	for	\$52.50
125	" "	" "	37.50
85	" "	" "	25.50
75	" "	" "	22.50
60	" "	" "	18.00
			All Net

CLOSES IMPORTANT DEALS.

Clifford R. Ely Arranged with Prominent Houses in Memphis, Tenn., and Washington, D. C., to Handle the Columbia Graphophone Co.'s Products—The Two Concerns Distinctly Prominent in Their Territories.

Clifford R. Ely, road ambassador for the wholesale department of the Columbia Graphophone Co., returned to New York last week after a month's



C. R. Ely.

trip through the South and near-by Eastern territory that was unusually successful even for this result-producing road man. Mr. Ely reached New York headquarters in time to greet the host of dealers attending the annual convention of the National Association of Piano Merchants, many of whom are Columbia advocates, maintaining extensive and successful Columbia departments.

Two of the more important deals closed by Mr. Ely on this trip were the D. B. Lowenstein Co., of Memphis, Tenn., and Woodward & Lathrop, Washington, D. C. In a chat with *The World* Mr. Ely called attention to the importance of these new accounts, which he states are deserving of far more than passing attention.

"The D. B. Lowenstein Co., of Memphis, Tenn.," stated Mr. Ely, "is known as the 'Marshall Field' and 'John Wanamaker' of the South and caters to a class of people who thoroughly appreciate quality and value. The D. B. Lowenstein Co. is the largest store in Memphis, and the fact that it has decided to maintain a Columbia department is indeed a valuable indication of the prestige of Columbia products. The store is planning to go after business energetically and has already erected five demonstration booths which are furnished in a dignified and high-class way. Earl Silliman, formerly assistant manager of the Columbia Graphophone Co.'s headquarters in Birmingham, Ala., has been appointed manager of this new and important department.

"Woodward & Lathrop, Washington, D. C., which is one of the finest department stores in the country, is the aristocratic store of the capital city. This store has never heretofore carried on anything but a strictly cash business, and the placing of Columbia products in this famous establishment is indeed a tribute to our company and its standing. About five booths are now being constructed, and John Affitica, formerly connected with the Flatbush avenue Columbia department of F. G. Smith, has been appointed manager. These two deals are but a part of the total results of this Southern trip, but they give a fair idea of the success that Columbia products are achieving."

The whole business world rests on a foundation of confidence. When confidence is gone business is gone. Individual salesmanship depends upon confidence as much as any other transactions in business.

MISAPPREHENSION AS TO COPYRIGHT.

When Can a Copyright Be Obtained—Modus Operandi—Numerous Inquiries Answered in Connection with the Present Interest Displayed in the Designed Registration Bill.

The interest in the "design registration" bill now in Congress has caused numerous inquiries to come to us from manufacturers and dealers who wish to know what rights they have in designs and names at the present time, and this has also brought forth the question from many sources whether or not they could not "copyright" this word, or title, or device, sometimes referring to a letterhead, sometimes to a trade-mark, sometimes to a descriptive phrase and sometimes to a design. These inquiries indicate that there is a general misapprehension as to copyright which should be corrected, and which will be clearly seen when it is understood that the only things that one can possibly copyright under the law are works of literature, music, drama and the fine arts. A title, a name, an outline cannot be copyrighted.

Sometimes protection may be had for trade-marks or trade names under the State laws or under the trade-mark laws of the United States, but this protection has nothing to do with copyrights. Trade-marks are registered in the Patent Office as are design patents, which are issued for various terms of years. However, trade-mark right may not be obtained in a geographical name or an adjective or phrase of description or in a proper name, while a design patent must show some novelty and invention.

Under the proposed design registration law protection would be afforded to the registrant who is first to register a particular design, irrespective of whether it contained novelty or invention, and the registration would practically date from the time the same was sent to Washington with the fee, without any waiting for the same to be passed upon by the Patent Office. Every original production in the way of a design would be entitled to registration protection as against imitation or duplication, one of the advantages of the proposed registration being the facility and cheapness by which the registration would be obtained. There is no doubt that under the present laws as to design patents greater protection is afforded the manufacturer than under the proposed design registration law, because if a manufacturer now receives a design patent he can restrain as an infringement any design that looks to the casual buyer to be the same as his, whether or not the outlines are identical. But the trouble with the present law lies in the delay in getting the design patent and the expense incurred.

To those who have proposed the use of the copyright as a substitute for both, we assure them, says *The Jewelers' Circular Weekly*, that their suggestion is absolutely without merit or reason, as the copyright law contains no provisions under which any such protection can be granted.

To guy visitors or to give short, flippant answers even to stupid or impudent people is a great mistake. Meet rudeness with unfailing patience and politeness and see how much better you feel.

DEVELOPING COUNTRY TRADE.

How J. J. Bennett, of the Columbia Traveling Staff, Toured the Ozark Mountain Foothills—Made Some Important Connections.

(Special to *The Talking Machine World*.)

St. Louis, Mo., June 10.—J. J. Bennett, of the Columbia traveling staff here, returned early this month from four days at Sullivan, Mo., in the Ozark Mountain foothills, where he assisted J. H. Bennett, not related, in getting started in rather a novel talking machine undertaking, at least for this section:

Sullivan is only a small town, and is not equal to supporting a pretentious talking machine business, but Mr. Bennett proposes to make the "whole mountains and valleys" his field. He is a former real estate man, and knows well the character of the residents in and about Sullivan, and he has concluded that they are as anxious to welcome the talking machines in their homes as their fathers and mothers were the sewing machine, and he is going to present it to them in exactly the same way.

As a starter, Mr. Bennett has bought two automobiles and two horse rigs, and has hired men as solicitors. Each will take a capacity load and go out and demonstrate wherever he can get an audience, and sell wherever he can get the money. Mr. Bennett believes there are great possibilities in his field, and he is going into the business on a large scale, expecting to have fully 100 men in the field before the summer is over. His activities during the winter will depend largely upon the weather and other conditions, but he believes that he can keep his force at work during the winter, too, when the evenings are long and entertainment is needed.

The first four days the four rigs were out eleven sales were reported. That, Mr. Bennett says, was a fair record for the untrained men. He thinks they will do even better after they get into the work. "The dance craze is reaching everywhere, and music is becoming a necessity, even in the mountains," says Mr. Bennett, "and I am going to carry good music where a piano would be useless."

There is a peculiar feature about Mr. Bennett's territory, in that scores of city families have summer homes on the mountain sides, and many of these have good machines at home, but have not taken them to the summer cottages, and a good many have expressed a willingness to buy low-priced machines for use in summer. Indeed, it was these expressions that gave to Mr. Bennett his idea, and then he saw the great void in hundreds of prosperous farm homes that he knew, and decided it was both a mission and a business field.

As a starter for his business, Mr. Bennett bought more than sixty of the United States machines when that stock was sold out. He will make the Columbia line his leader, and will sell Edison cylinder machines.

The Columbia warerooms in this city have been following a somewhat similar line of work in developing the summer hotel and clubhouse trade. Along the Meremac River, a popular boating stream, are hundreds of clubhouses and farm homes where city folk spend the heated weeks. Salesman Odell has been traveling this country and other summer resort territory, giving concerts at clubhouses and at farm homes wherever there is a sizable party of summer boarders. After an evening of splendid entertainment or dancing, and this dancing thing will not down even for a terrific heat that marked the last of May and first weeks of June in this country, he talks sale. Very few clubs or landlords fail to come across, for the average summer host, even if he is a farmer, fully realizes that a contented party of boarders is a whole lot more easily fed than those city folk who find the attractions of the pig pen and the cow lot growing stale to their city-trained ideas.

Miss Bessie Fireside, of the Columbia staff, will spend her vacation in Vienna, Ill.

When you have found out what line of goods attract the most people in your store, go into that line as strong as you can.

"Standard" Record Cleaner

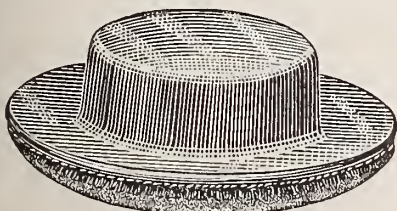

Price, 50 Cents, List
Patented June 2, 1914.

ARTISTIC AND ATTRACTIVE
Grips the record surface and
clings as if on rails.

Extended brush area cleans record
with one sweeping circuit.

Send 10 cents in stamps for a sample cleaner. Write on your business letter head only. Place regular orders through your jobber.

STANDARD GRAMAPHONE APPLIANCE CO.

173 LAFAYETTE STREET,

NEW YORK

NEW YORK TRADE CLOSING GOOD SUMMER BUSINESS.

Jobbers and Dealers Co-operating to Secure Hotel and Camp Trade—Record Shortage Not So Acute—Higher-Priced Machines in Demand—Recitals Attracting Many Out-of-Town Callers—Red Seal Records Maintain Popularity—New Columbia Record Stand.

The local talking machine trade the past month has been generally satisfactory to all members of the industry, although here and there some of the dealers have complained that the business depression which has been hurting business throughout the country affected their sales during the past few weeks. On the whole, however, the talking machine business has fared exceptionally good, and May kept up the excellent record attained by the previous four months' sales totals.

There is no doubt but that the active and progressive talking machine dealer realizes that the summer season should not be passed up as the natural dull season of the year. On the contrary, the majority of dealers are making energetic efforts to make the summer months compare favorably with the other seasons of the year. With the dance craze continuing unabated, the 1914 summer months should prove profitable to the aggressive dealer who takes advantage of the various summer amusements to drive home the fact that the talking machine with a goodly supply of records is practically indispensable to ideal summer camp or bungalow life. The hearty endorsements given the talking machine and records by the leading exponents of the modern dances can be used to excellent advantage by the dealers who really try to secure summer business.

Summer Hotel Prospects.

New York's proximity to so many watering places permits the local dealers to make a special effort to develop the possibilities of summer business, and the results to date have been very gratifying. The consistent solicitation of the summer hotels has convinced the dealers that this class of sales has been sadly neglected during the past few years and even though the present dance craze should subside, the opportunities for closing sales to summer hotel owners, campers and general vacationists will be followed up closely by the members of the local trade.

Record Situation Clearing.

The jobbers and dealers have not complained as emphatically during the past month regarding record shortage as they did in the first four months of the year, although this does not signify that record business has fallen off. As a matter of fact, the majority of the dealers and jobbers closed a splendid May record business, but the cessation of general complaint is probably due to the fact that the trade as a whole realizes that the manufacturers are turning out more records than ever before, and that the scarcity of records can be attributed to the remarkable increase in the demand for records that has taken place in the past six months.

Blackman Co. Closes Good Month.

The Blackman Talking Machine Co., 97 Chambers street, New York, the well-known Victor and Edison cylinder distributor, reports the closing of a very satisfactory business during the past month, particularly in its Victor record department. The company is not only selling large quantities of dance records, but is steadily increasing its Red Seal record business. This class of trade is being consistently developed by the Blackman dealers, and a growing appreciation of the better class of music by the general public can be traced indirectly to the activities of talking machine dealers to increase their sales of Red Seal and operatic records.

New Columbia Record Display Stand.

"May was one of the best spring months we ever experienced," said R. F. Bolton, manager of the wholesale headquarters of the Columbia Graphophone Co., 89 Chambers street. "Our gain

over last May was about 30 per cent., and we are very well pleased with this figure in view of the general business depression that has been current in all mercantile lines. We are selling more of the higher priced machines than ever before, and the "Leader" at \$75 is gaining popularity week after week." This wholesale branch recently sent out to its dealers in New York a handsome and attractive record display stand that is winning favor wherever it is introduced. The stand is constructed of oak finished boards, and the coloring harmonizes perfectly with the neat and refined layout of the design. The stand, together with record strips to the number of forty, are sent to Columbia dealers in local territory at the nominal cost of seventy-five cents per month for a period of six months.

New Victrolas Sell Well.

"The new types of Victrolas X and XI are being praised by all our dealers," said G. T. Williams, manager of the New York Talking Machine Co., 81 Chambers street, Victor distributor. "The many points of refinement in these new types are appreciated by our clientele, who state that the new designs are meeting with a ready sale. The month of May just closed was the best in our history, showing a substantial gain over last May, which was a record-breaker. Both in machines and records our sales were considerably in advance of last year, and the outlook just now is very encouraging. Our efforts to co-operate with our dealers are being more and more appreciated, particularly in view of the recent record shortage, as we have endeavored to point out to our trade just how they can secure the most profits out of their record stocks."

Holding Edison Recitals.

The Edison disc department of Hardman, Peck & Co., 433 Fifth avenue, is holding informal recitals at its showrooms on the fifth floor of Hardman House, at which the Edison disc products are featured. H. N. Purdy, manager of this department, states that these recitals are proving very successful, attracting many interested music lovers, who are enthusiastic regarding the tone qualities of the Edison machines and records. Sales of high priced machines continue to have the call at this department, the high grade Hardman clientele evidently preferring to have the better grades of machines in their homes to harmonize with their decorations and furnishings.

Occupying New Home.

The new Fifth avenue home of the Columbia Graphophone Co. in the handsome establishment of F. G. Smith, 335 Fifth avenue, is now entirely completed, and Manager Hayward Cleveland can well afford to look upon his department with pride and admiration, as every detail in this new store is in complete accord with the prestige of Fifth avenue trade and surroundings. Assisted by a capable sales staff, Mr. Cleveland is already proving the value of this location, and being situated in the heart of the high grade piano and shopping district, is in an excellent position to secure high class business.

New Records Well Received.

In a chat with The World, A. N. Struck, the newly appointed manager of the Edison department of the Tower Manufacturing & Novelty Co., 326 Broadway, states that the new Edison disc records now being issued are winning words of approval from all his patrons. This particularly applies to the new dance records, which are making a hit with summer vacationists, who wish to take them along for their week-end parties.

In the Department Stores.

The Victor and Columbia department at Gimbel Bros. store, Thirty-third street and Sixth avenue, is making a special display of dance records, a separate table being allotted to each popular dance, with appropriate records displayed at each table. This unique arrangement is attracting attention and producing sales.

The Columbia and Victor department in the Simpson-Crawford store, Twentieth street and Sixth avenue, was moved this week from the third to the fourth floor, where it occupies handsome quarters immediately adjoining the piano ware-rooms. A number of booths have been fitted up in modern, up-to-date fashion, and Manager Allan Welburn states that business has shown a steady increase during the past few weeks.

FEATURING EDISONS IN ST. LOUIS.

Silverstone Relegates Piano Stock to Standing of a Side Line and Goes After Phonograph Business in Energetic Manner.

(Special to The Talking Machine World.)

ST. LOUIS, Mo., June 9.—Mark Silverstone, Edison jobber, is featuring the name Edison more and more strongly in his advertising, and he makes no secret of the fact that he would use the name for his store except that he is still handling pianos as a side line to his talking machines, a department that he established when he first removed into the large building that he now occupies. He did not then anticipate the record-breaking jobbing business that would result from the Edison disc introduction.

Already plans have been completed for this summer's work of giving to the store increased facilities for the demonstration of the Edison machines. The present plan is to remove the cylinder machines and records to the second floor, which can be reached either by stairway or elevator, and converting three of the present demonstration rooms now used for cylinder trade into a recital hall, which will be soundproof, and will have a eleven-foot vaulted ceiling, and will seat sixty persons in comfortable chairs. Two additional demonstration rooms will be built on the main floor, and the general decoration scheme will be changed.

O. A. Reynolds, of the Silverstone sales staff, is making an extended trip into Mississippi, Tennessee, Alabama and Georgia. He is making an excellent record in the establishment of selling agents in the Southern country, and they promise much business if the cotton crop develops.

Mr. Schulte, of the sales force, recently went to the Roe Grammar School in this city and made cylinder records of the chorus work in each of the grades. The records will be kept at the school for future demonstration.

EILERS T. M. CO. INCORPORATED.

The Eilers Talking Machine Co. was recently incorporated at Seattle, Wash., for \$3,000, the incorporators named being C. H. Hopper, E. P. Kelly and J. W. Roberts. The new firm takes over the business of the Eilers Music House but will not present any new faces to the trade, for both Messrs. Hopper and Kelly are well known in talking machine circles in Seattle as being connected for a number of years with the Eilers house, Mr. Hopper being assistant manager. The officers of the company will be C. H. Hopper, president; J. W. Roberts, vice-president; E. P. Kelly, secretary. The headquarters are in the Alaska Building.

BASIS OF GOOD HABITS.

Good habits are produced by an organized mind. The more good habits a man has the more efficient and useful he becomes. For a habit once formed acts with very little expense of energy, thus energy is conserved for the pursuit of other work. A well organized mind is one of the most valuable possessions within the reach of man. Just how to secure it is too large a problem to discuss in the short space allotted here, except to say, conscientious, constructive work is the basis of its possession.



Collect Your Over Due Accounts WITH "RICKERT'S" COLLECTION PICTURES

The newest and most successful collection method ever devised. Printed on imported gummed paper, in startling colors, size of a postage stamp—humorous so as not to offend—yet serious enough to make the money come. Simply moisten them and stick to statement or invoice and mail. No dunning letters required. Fifteen designs. Illustration shows one. For \$1.00 bill, will mail prepaid 1,000 assorted. Sample free.

WILSON E. RICKERT, Allentown, Penna

Italian



Chinese

Polish



A Most Potent Salesman

Reach Your Prospects Through the Medium of Their Mother Tongues.

- | | | |
|------------------|-------------|------------|
| Arabian | Hawaiian | Norwegian |
| Bohemian | Hebrew | Polish |
| Canadian | Hollandishe | Portuguese |
| Chinese | Hungarian | Roumanian |
| Croatian-Servian | Italian | Ruthenian |
| Cuban | Japanese | Russian |
| Danish | Jewish | Servian |
| Deutsch | Korean | Slovak |
| Finnish | Latin | Swedish |
| French | Lithuanian | Spanish |
| German | Mexican | Turkish |
| Greek | Neapolitan | Yiddish |

In addition to the largest and most complete stock of Domestic Records in the United States, we carry the entire Catalog of Victor Foreign Records.



Hebrew

Greek



Japanese



German

NEW YORK TALKING MACHINE COMPANY
81 Chambers Street, New York

SEND US YOUR ORDER FOR RECORDS AND LITERATURE.



The four Columbia Dance Instruction Records will make the talking machine dealer's Summer months the liveliest kind of a period. If you don't want to dance don't listen to them.



(Write for "Music Money," a book "full of meat" for those dealers interested in quick and frequent turnover of capital.)

Columbia Graphophone Company
Woolworth Building, New York

CANADIAN TALKING MACHINE DOINGS SUMMARIZED.

Demand for Foreign Records Growing in Canada—Pathé Freres Appoint Special Representatives—Nordheimer Piano & Music Co. to Remove—Will Have Spacious Quarters as Well as Recital Hall—Columbia Demonstration by Miss O'Brien Interesting.

(Special to The Talking Machine World.)

TORONTO, CAN., June 10.—H. V. Smith, of Smith & Smith, North Sydney, C. B., was a recent trade visitor to Toronto en route for Chicago, New York and other United States points. This eastern Canadian firm has a growing talking machine and record business.

A new 46-page catalog of Columbia-Rena records has been recently issued by the Columbia Graphophone Co., Toronto, containing the cream of its English records.

Miss Mary O'Brien, special school representative of the Columbia Graphophone Co., Toronto, is carrying on important educational work for that firm. Three demonstrations and lectures have been given in Toronto before the Catholic teachers and separate school boards, one at each of the Loretto Abbey, St. Joseph's Convent and De La Salle Institute. Miss O'Brien, who has gained valuable experience in newspaper work, was assisted by Professor Frederick Goodwin, head of the Columbia firm's educational department at New York.

I. Montagnes & Co., European manufacturers' agents, whose special agencies include talking machine needles, have removed to new premises in the new Ryrie building, Toronto.

The well-known European house of Pathé Freres, London and Paris, have now a special representative in Canada in the person of Frank J. Bowers, who is here in the interests of that firm.

Mr. Bowers spent a week in Toronto, and while



Safety Needle Controller

A sound box handle which every Victor owner should have.

Prevents sound box from damaging records; no pricking fingers with needles; permits full view of record for proper starting.

Retails 25c. (Liberal Discount)

Sample sent for 20c. stamps and name of jobber.

C. & C. SALES CO.

120 BOYLSTON STREET, BOSTON, MASS.

here practically concluded arrangements for the distribution in Ontario of Pathéphones and Pathé disc records. It is his purpose to arrange for a wholesale agency in each Province. Mr. Bowers departed for the West, and on his return to Toronto those of the local trade who have not already inspected the Pathé line will be given an opportunity to hear disc records on the Pathéphone. This machine uses a sapphire reproducer, and the Pathé line is well-known the world over. Pathé Freres have factories in London and Paris, and arrangements are now being made for a United States plant.

Field for Foreign Records Widening.

There are dealers in Canada who have awakened to the possibilities there are for the sale of talking machines and records to foreigners. The key to the situation is, of course, the wide range of foreign records. Although some retailers are deriving a good substantial profit from the sale of foreign records, it is a field ready for harvest that has been only scratched over on the surface.

According to the last census there were in Canada 107,535 Scandinavians, or persons of Scandinavian descent; 75,681 Jewish; 27,774 Chinese; 45,411 Italian; 2,054,890 French; 393,320 German; 15,497 Finnish; 33,365 Polish; 9,021 Japanese, and other nationalities varying from 2,500 up. These amounts since the census was concluded some time ago have increased by many thousands.

Plans Out for New Nordheimer Building.

After seventy years on King street East, Toronto, the old established firm of Nordheimer Piano & Music Co., Ltd., has gotten out plans for a new building on the northwest corner of Yonge and Albert streets, opposite Eaton's, having a frontage of 110 feet on Albert street. There is a lane at the rear from which goods will be despatched and received directly to and from the freight elevator to be located in the northwest corner of the building. The new building is to be of six stories and basement, with entrances from Albert street and from Yonge street. A recital hall with a seating capacity for 500 persons is to be located on the first floor, and ample provision will be made for artists' studios. The basement will be devoted to the talking machine department, which it is proposed to enlarge, and the sheet music retail department will have a prominent location on the ground floor, where also will be located large piano showrooms. The immense frontage of plate glass on two streets will give an unusually large window display space, the pedestrian and vehicular traffic being particularly heavy at this point.

Successful selling depends on three things:

Getting a Customer.
Selling Him.
Keeping Him.

BUSINESS OUTLOOK EXCELLENT.

Schmelzer Arms Co. Break All Banner Records in Trade Growth.

(Special to The Talking Machine World.)

KANSAS CITY, MO., June 6.—A. A. Trostler, manager of the talking machine department of the Schmelzer Arms Co., is enthusiastic over present trade conditions. He remarked to The World that the first five months of 1914 had surpassed any five months in the talking machine business since the



Schmelzer Arms Co. Showroom.

firm was established. Last year was the biggest Victor year in the history of the Schmelzer Arms Co. Mr. Trostler added: "We are frank to say that prospects for the balance of the year, with the two hundred million bushels of wheat in the State of Kansas alone, and the same proportion of crops in the States of Oklahoma, Nebraska and Missouri, will create a business which will correspond to any twelve months that we have ever enjoyed."

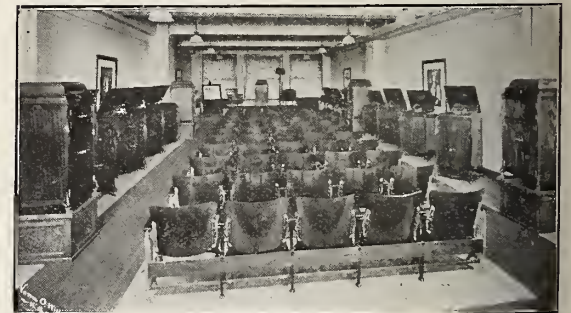

The Recital Hall.

The views shown herewith represent the concert hall, one of the Victor display rooms, which is used for demonstrating. The company devotes a space of seventy-five feet frontage by 135 feet deep to the retail Victor department. Complimentary concerts are given daily in the concert hall from 10 a. m. to 5 p. m.

ENLARGE "TALKER" SPACE.

The Denver Dry Goods Co., of Denver, Col., has greatly enlarged the space devoted to its talking machine department to the new quarters, superbly decorated, have attracted many customers. W. C. Wyatt is manager.

The reason there is plenty of room at the top is because most of the people who get there fall off.

ANTI-BUSINESS LEGISLATION.

Should Congress Create an Interstate Commission, the Consumer Would Bear the Brunt of Total Yearly Cost of \$58,000,000, According to James E. Bennett—"Talker" Trade No Exception to the General Rule.

Not long ago a New York newspaper printed an article in which it stated that about \$10,000,000 would cover the total yearly cost to the consumer of the proposed Interstate Trade Commission. The creation of this commission is now being discussed by Congress, and according to good authority there seems every likelihood that the legislators at Washington will establish such a body.

If such is the case every corporation will be amenable to investigation by the commission. The piano industry will not be exempted.

Concerning the stupendous expense of such a commission, which cost will ultimately be paid by the consumer, James E. Bennett, general secretary of the Printing Press Manufacturers' Association, has written the following letter:

"The total yearly cost of this commission, which Congress seems determined to create, will amount to approximately \$58,000,000, all of which ultimately must be paid by the consumer.

"There are about 309,000 corporations which filed income tax reports, and after deducting the 7,500 national banks, 17,000 State and savings banks, 3,000 railroad corporations under the Interstate Commerce Commission, and making allowance for corporations which do no business across any State line, it is estimated that there are about 150,000 corporations which will be subject to this erroneously named 'anti-trust bill.'

"The commission of five men will have many tasks. One is 'to investigate the organization, business, financial condition, conduct, management, and its relation to other corporations of any corporation engaged in commerce.' If it investigates one corporation and makes its report public, it ought in fairness to investigate all; and if it does not investigate all, then some guilty corporations may escape. Now if one examiner can investigate an average of one corporation each week, he could look after fifty a year. That would require 3,000 examiners. They, being experts, would require salaries of at least \$3,000 a year, or a total of \$9,000,000 for this item.

"Each corporation must also file annual reports. Such reports to be useful for the purposes of the commission must be very specific and include copies of all trade agreements and contracts and be under oath and certified by public accountants. To make up such reports would easily cost each corporation an average of \$150 a year, or a total of \$22,500,000 for this item.

"These reports must all be indexed, filed, analyzed and compared for traces of possible shady stock issues, baseless bonds, derelict directors and interlocking interests of monopolistic tendencies. This would take a large and very competent office force. The cost of tabulating and publishing the 1910 census will be \$8,500,000, so it is safe to say that this item of the operation of the trade commission will be at least \$4,500,000.

"Every person who is a director in two or more corporations carrying on a competitive business must either resign or file a petition with the commission, have a hearing and try to get an order permitting him to serve in both corporations. To employ attorneys, attend hearings in Washington and get this proceeding through will cost on an average

\$300, and as probably 20,000 such applications will be made the first year, this item would cost the corporations \$6,000,000.

"All 'holding' companies must either dissolve or within one year make application for permission to continue business. Such applications will entail tedious hearings and exhaustive evidence taking, and will easily cost an average of \$1,000 to the corporation. There are probably 10,000 such corporations, and to carry out these proceedings would cost the corporations \$10,000,000.

"To cap the climax, Section 12 provides that where stock is to be issued for property the commission shall investigate the value of the property and issue a certificate before the stock can be issued. There are at least 20,000 corporations organized each year in the various States which contemplate engaging in commerce and which buy some property with stock. All of these would have to submit their inventories and appraisals to the commission and probably have hearings and offer evidence. The question of value of 'good will' would be a very troublesome problem, and each of these proceedings would undoubtedly cost the corporation on an average of \$300, or a total of \$6,000,000. Incidentally, with all these duties and many others, the commission would soon be years behind in its work and the business men would have to await their turn for relief.

"Of course, this looks absurd, and it certainly is. Nevertheless it is true, and if this ridiculous trade commission is formed with its far-reaching and preposterous powers, the ordinary citizen will have

to pay this penalty. The benefits derived will be nothing except to the employes of the commission, who will nearly all be exempt from civil service requirements and only need a 'pull' to get positions.

"Millions spent to spank the industries of the country in order to regulate them! This bill in principle is an attempt to work the 'third degree' upon every business corporation, and is the essence of 'Government by Suspicion.'"

WHAT DANCE EXPERTS SAY.

The Haverty Furniture Co., Savannah, Ga., Columbia dealer, recently received the following letter from Mr. and Mrs. Sol C. Rice, prominent dancing instructors in this city:

"We are using the Columbia 'Favorite' Grafonola and Columbia records at our dancing academy, where they are attracting extraordinary attention. The records are played in perfect dance time, and our patrons are delighted and frequently encore them. If at any time we can be of any assistance to you, we are at your command, Yours very truly (Signed), Mr. and Mrs. Sol C. Rice."

SUFFERED FROM FIRE.

In the fire which occurred recently in Marion, Ind., the Butler Music Co., which occupied quarters in the Wyandotte Block, suffered considerable damage to its stock of supplies and instruments in the basement of the storehouse.

1897 SEVENTEEN YEARS 1914

SEVENTEEN YEARS' EXPERIENCE IS VALUABLE

In 1897 J. NEWCOMB BLACKMAN started in the TALKING MACHINE business and STUCK TO IT. It was a case of CONFIDENCE, PLUCK, HARD WORK and a firm belief that FAIR DEALING and SERVICE still mean SUCCESS.

SUCCESS HAS NOT YET BEEN CORNERED

If it had been the BLACKMAN TALKING MACHINE CO. could not have just celebrated WITH ITS EMPLOYEES the close of its 12th successful year and keep in force A PROFIT-SHARING plan established FIVE YEARS AGO.

DOES THIS INTEREST DEALERS? READ ON

VITALLY so—if they are BLACKMAN DEALERS or will become so. Don't you think SEVENTEEN YEARS of SUCCESSFUL CONCENTRATION shows up in BLACKMAN SERVICE? Does TEAM WORK and HARMONY among EMPLOYEES produce SATISFACTION for customers? Who don't know the ANSWER?

IT'S WORTH REAL MONEY TO BE A "BLACKMAN DEALER"

Are you going to be SATISFIED with anything claimed to be "JUST AS GOOD"? Not when you can TRY the GENUINE and AT THE SAME PRICE.

When will it be? Join us NOW.

BLACKMAN TALKING MACHINE CO.

J. NEWCOMB BLACKMAN, Pres.

97 CHAMBERS ST., NEW YORK



NAME PLATES
DECALCOMANIE

Why not apply a transfer nameplate on your talking machine cabinets?

WRITE FOR SAMPLES AND PRICES. SKETCHES FREE

GEO. A. SMITH & CO. INC.
74 CORTLANDT ST., N. Y.

EDISON
Winnipeg Piano Co.
Koch & Davy
W. A. T. E. F. Co.



Full dance instructions on one side and a complete dance selection on the other.



Full dance instructions on one side and a complete dance selection on the other.

The biggest talking machine business since the demonstration

You know very well that millions of people in this country who could learn all alone in this expense of private lessons

Well, they can do it

Each of these

Four Dance Records

has a regular dance selection of present records. But now with *instructions how to dance* the One-Step, the Hesitation, the

Ten million people are reading the Saturday Evening Post and away those who come to you you going to follow along and cash in on the biggest talking machine business since the demonstration

Your nearest Columbia dealer (see list of this issue) has a supply of these for you.

COLUMBIA



Graphophone

WOOLWORTH BROS.

In the record the Columbia cord.

hundreds of thousands
be dancing if only they
es without going to the
blicity of class lessons.

tion Records

ne side—just like our
er side *are complete*
particular dance—the
and the Tango.

out these records in the
Are you going to turn
or those records; or are
of least resistance and
his dance business?

(see inside cover page
records on hand to send

COLUMBIA

ompany

NEW YORK



Full dance instructions on one side and a complete dance selection on the other.



Full dance instructions on one side and a complete dance selection on the other.



Joan Sawyer, vaudeville's most popular danseuse, has her own Persian Garden Orchestra making Columbia dance records. One of these records will be announced shortly.



(Write for "Music Money," a book "full of meat" for those dealers interested in quick and frequent turnover of capital.)

**Columbia Graphophone Company
Woolworth Building, New York**

KRAKAUER AND THE EDISON.

The Well-Known Piano House of New York Featuring the Edison Disc Phonograph to Excellent Purpose — Handsome Display Quarters and Special Recitals Interest the Public and Win Customers and Friends.

Krakauer Bros., one of the old-time distinguished piano houses, which recently secured the agency for Edison disc phonographs, are displaying them to great advantage in their ware-

A. Edison, Inc., they say: "We find the Edison instrument a worthy adjunct, as to quality of tone, to the Krakauer pianos. The disc has given entire satisfaction and has caused many surprises to musicians and critical minds." And the sales of records prove the correctness of this deduction.

Andrew H. Mangold, manager of the Krakauer establishment, has demonstrated the Edison instruments at a number of musicales recently and has attracted most fashionable audiences, who have been aroused to great enthusiasm in connection

founder, Simon Krakauer, of whom a portrait appeared. The house of Krakauer has long been noted for its adherence to the highest ideals in the constructive department of piano making, having paid particular attention to the development of tone quality.

H. C. BROWN ADDRESSES PIANO MEN.

Advertising Manager of Victor Co. Emphasizes Importance of Truthful Advertising and the One-Price System at Banquet of National Association of Piano Merchants.

Henry C. Brown, advertising manager of the Victor Talking Machine Co., was one of the speakers at the annual banquet in connection with the convention of the National Association of Piano Merchants at the Hotel Astor on June 9 and which was attended by over 650 piano men and their friends. Mr. Brown delivered an interesting address on the importance of truthfulness in advertising and the necessity of the one-price system as conditions precedent to success in business, and closed with an appeal for the piano men to do all in their power for the support of the Stevens bill, which provides for the maintenance of prices on trade-marked articles. The arrival of Governor Glynn, of New York, the guest of honor, during Mr. Brown's address, forced the latter to deliver his speech in sections, as it were, but nevertheless he created an excellent impression.

PLAYED GREAT GAME.

At Least We Are Sure the Winning Team of the Forces of the New York Talking Machine Co. Did—Particulars Later.

There was great excitement in Van Cortlandt Park last Saturday afternoon. Diamond No. 3 was surrounded by the forces of the New York Talking Machine Co., carrying on an active campaign of "rooting" for their favorite team. The participants in the struggle for baseball honors were the Married vs. the Single Men of the New York Talking Machine Co. As The World closed its last form before the result was known, we are safe in saying that the best team won. But even that will be determined later, for a return game is inevitable.

Make sure of your aim—no one feels meaner than the fellow who sends a wink across, and it doesn't land.

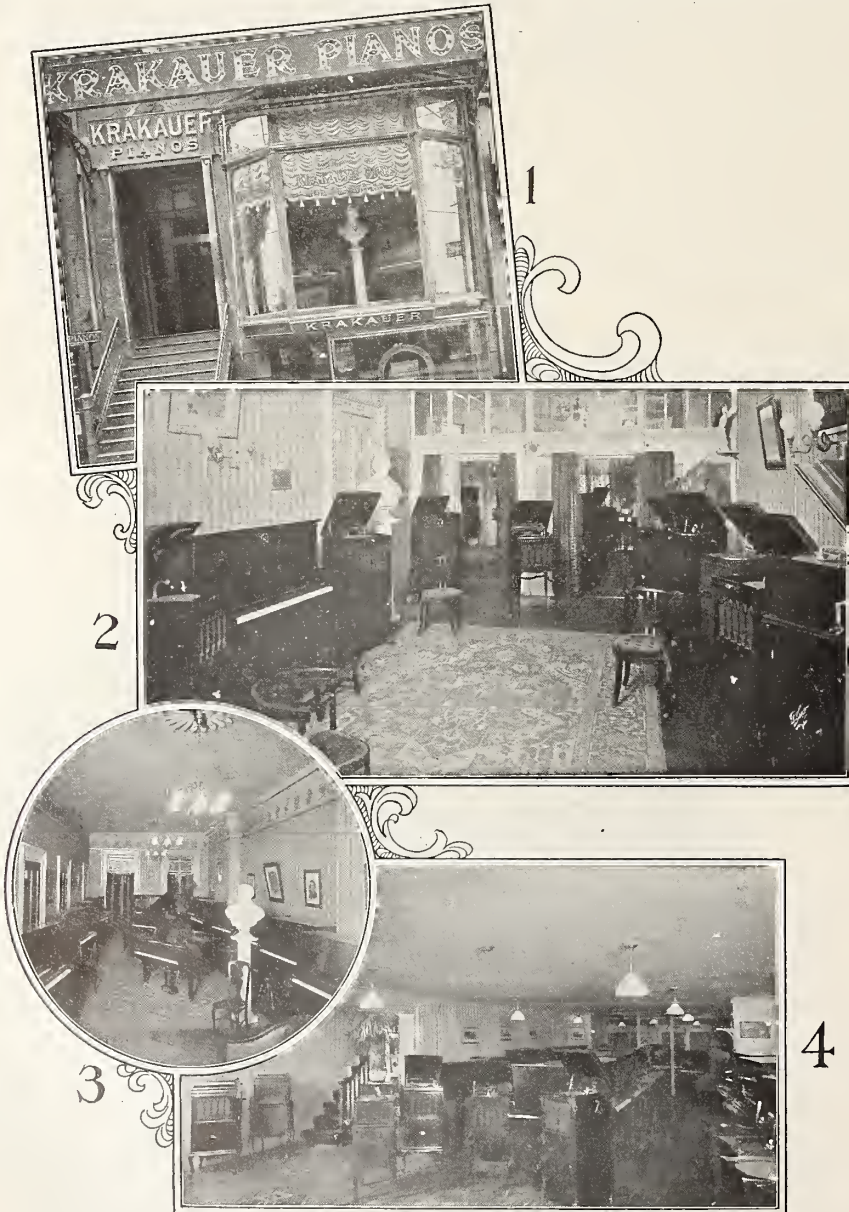

Exterior and Interior Views Krakauer Bros., New York.

1. Exterior of Office Building, 17 East Fourteenth Street. 2. One of the Edison Disc Recital Parlors. 3. Entrance to Edison Recital Parlors. 4. Edison Salesroom.

rooms at 17 East Fourteenth street, New York. The illustration herewith will give an idea of the extent and equipment of the Krakauer quarters.

Krakauer Bros. have expressed the greatest pleasure and satisfaction with the wonderful tone qualities of Edison discs, and in a letter to Thomas

with the interpretation of the programs prepared by him.

The Edison Phonograph Monthly, by the way, recently devoted considerable space to the Krakauer establishment, giving a history of the house and extended reference to its distinguished

I. DAVEGA, Jr.

125 WEST 125th STREET, NEW YORK

Victor Distributor

PROMPT AND ACCURATE SERVICE

DEALERS: Write for our Victor Pennant. Sent with our compliments.

SIX NEW EDISON ARTISTS

Who Will Make Their Debut in the Blue Amberol List for August—All Prominent in Their Respective Spheres of Activity—Have Made Some Very Notable Records.

Six new artists will make their appearance in the list of Blue Amberol records for August issued by Thomas A. Edison, Inc. They will include



Paul Althouse, Tenor.



Mildred Howson Hartley, Contralto.

Paul Althouse, one of the distinguished members of the Metropolitan Opera House Co., a tenor of distinction, who has been heard with great appreciation and interest. He is a pupil of Oscar



Arthur Blight, Baritone.



Edwin Swain, Tenor.

Saenger, the New York teacher, who has turned out so many eminent artists. Mr. Althouse has selected that beautiful number from "Faust," "All Hail, Thou Dwelling Lowly," in which to make



Hendrika Troostwyk, Violinist.



Fred Duprez, Monologist.

his debut. Other artists who will be heard in the August list are Mildred Howson Hartley, contralto, who has appeared in opera and concert with great success. She sings Blumenthal's "Sunshine and Rain." Arthur Blight, a baritone of recognized worth, will be represented in the August list by "Beauty's Eyes," a lovely song, which will undoubtedly appeal to his admirers. Another gifted artist who makes her debut for the Edison Co. is Hendrika Troostwyk, violinist, who has played with a number of orchestras, winning great acclaim. She is heard in a composition of her own entitled "Springtime," which displays her technique and musicianship most effectively. A concert singer widely known is Edward Swain, who long occupied a position as soloist with the Lafayette Avenue Presbyterian Church, New York. Mr. Swain's

voice is a remarkable one, and he is especially noted for his perfect diction—a valuable acquisition. This varied list is made complete by the appearance of Fred Duprez, monologist, who has chosen as his initial selection for the Edison Co. "How to Be Happy Tho' Married." This monologue has been given by him in theaters all over the world and has been laughed at by millions. It now enters into a new sphere of publicity.

HE USED THE ECLIPSE ALL RIGHT!

The Columbia Co.'s advertising department was greatly surprised the other day to receive a proof from one of the local newspapers wherein a cut of an eclipse of the sun was prominently displayed. It seemed that this advertisement was intended for the exploitation of the company's "Eclipse" machine and dance records, and as no cut of the machine was available, the newspaper was instructed that a cut of an "eclipse" was to be inserted. The compositor read these instructions literally, and the proof as submitted showed a glorious illustration of an eclipse of the sun or moon that would have delighted astronomers but

would hardly have been appreciated by talking machine prospects.

TO TEACH MUSIC CRITICISM.

There is a class at the Chicago Musical College where students are taught how to become music critics. It would be interesting, remarks the London Daily Telegraph, to know the methods adopted. But no matter. For evidently the pupils are on the right road to achieving distinction in that particular walk in life. Edward Moore, their teacher, asked them recently to write their impressions of a certain "soulful" composition. "Whenever I hear it," wrote one girl pupil, "I feel like putting my head on some one's shoulder." To which the professor appended the comment: "Concert seats next to yours are bound to be at a premium when you become a critic."

Women wear so much false hair nowadays that it is extremely difficult to tell which is switch.

The man who feels that he has a message for the world generally sends it collect.

(From Scientific American, May 23, 1914.)

"An Attachment for Talking Machines and Gramophones Which Improves Their Reproduction"

IN THE Scientific American of September 27th, 1913, we published an article on an invention patented by Mr. M. B. Claussen for amplifying the reproductions of talking machine records, which invention consisted in inserting the steel reproducing needle through a specially formed celluloid disk. Simple as the invention is, the effect is remarkable. With a fine needle a volume of sound can be obtained which exceeds that produced by a coarse needle, with the additional result that all the delicate shades which only a fine needle can reproduce and which escape a coarse needle, are heard. Mr. Claussen has patented a modification which permits the use of the fiber needle. If anything, the effect of the celluloid disk is even more pronounced than with the steel needle. Those who use fiber needles know that they are superior to steel points because the scratching is reduced, the tone is purer, and the records are not worn away so quickly. Mr. Claussen passes the fiber needle through a ball and socket joint in the center of the disk, so the needle can be adjusted to any angle. It is now possible with this invention to use the fiber needle with those records for which it is peculiarly adapted, with the assurance that the sound to be obtained is greatly amplified and a richness of quality obtained otherwise quite impossible."

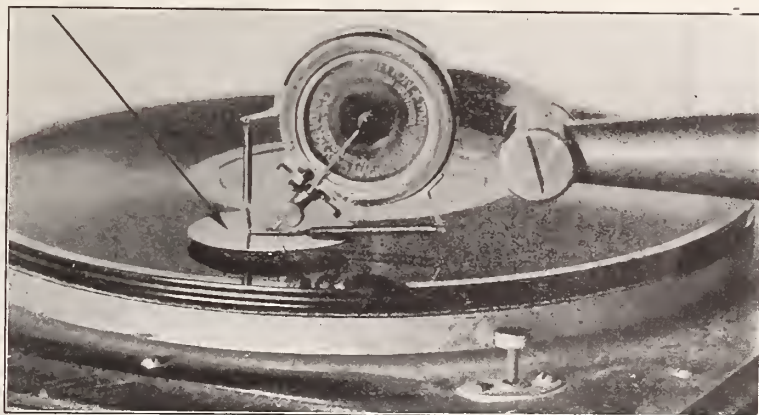

Steel Needles Masterphone, \$1.00

For Fibre Needles, \$1.50

DEALERS—Write for Special Offer during Summer months. It is a money-maker and custom builder.

The Masterphone Corporation

Room 192 45 Broadway New York City

FROM OUR CHICAGO HEADQUARTERS

E. P. VAN HARLINGEN, Manager
HENRY S. KINGWILL, Associate

World Office
Consumers' Bldg., 220 South State St., Chicago
Telephone: Wabash 5774

(Special to The Talking Machine World.)

CHICAGO, ILL., June 11.—Talking machine dealers feel assured of not only a good but a large fall business. The Farmer (with a big F) is going to have money to spend this year, and he has already evinced a predilection for talking machines, which the dealers and makers will try to satisfy. The reason for this feeling is the continuance of the highly favorable crop reports from the territory most immediately tributary to Chicago. The wheat situation is most unusual. The acreage is larger than ever before, the condition better than before known, and the reports from our chief foreign competitors are such as to promise that prices will remain at least fair. On this basis of facts the American farmer will be some half a billion dollars better off on account of his wheat crop alone, while the other small grains, especially oats, are in almost as good a position as wheat, except that there is not so much of them. If corn fulfils its present promise the barns of the country will be actually bursting with wealth of this season's harvest—and what will the farmer buy? Apparently, from recent examples, autos to go about in and talking machines and player-pianos to amuse him at home.

G. W. Davidson Painfully Injured.

G. W. Davidson, of the Talking Machine Shops, was painfully injured a short time ago, when an automobile which he was driving came into collision with a truck. Three fingers of one hand were badly lacerated and Mr. Davidson suffered severely from the pain and loss of blood.

Miss I. Caldwell, of the Shops, leaves for a trip through Europe June 18, sailing on the "Calgary" of the Allan Line leaving Quebec. Miss Caldwell will be gone for three months and will visit England, Scotland, Holland, Belgium, France, Spain and Italy, also making other stops at Mediterranean ports. She will return by one of the White Star steamers over the Southern route.

Attractive L. & H. Window.

Lyon & Healy are showing by illustration how essential to the proper equipment of a family camping-out party is a talking machine. In their window they have placed a graphic representation of a party of campers, consisting of father, mother and child. The child is playing around with a dog, the mother is listening to a Victrola, and father—he is catching fish, as is quite proper when a father

of a family takes his wife and offspring out into the wilds beyond the end of the horsecar line or more modern trolley. The scene is pretty and suggestive that a Victrola would not be out of place on such an excursion. The scene is made the more complete and realistic by the introduction of a real babbling brook, beside which the tents are set, and squirrels and turkeys and other presumable residents of the locality to which our campers have hid themselves to be near to nature and her charms and away from the distractions of the city. Seriously, it is worth many times the trouble of carrying to have even a small machine and a limited selection of records to while away rainy days and evenings in camp and to entertain the welcome visitor.

C. E. Goodwin on Vacation.

C. E. Goodwin, manager of the Phonograph Co., is on a three weeks' trip to the East. The journey is made as a combination business and pleasure trip, for Mr. Goodwin plans to put in several days of hard work at the Edison factories at Orange, N. J.

Fibre Needles in Summer Use.

That fibre needles are constantly increasing in popularity and are being used even by machine owners who are taking their instruments with them to their summer homes is the conclusion reached by Wade & Wade, for the big sales of the Wade fibre needle cutter at the present time can be quite clearly traced to the summer influence.

Columbia Notes.

Wholesale business of the Columbia Co. is reported by District Manager W. C. Fuhri as being very good for this time of the year, with especially heavy calls from dealers on the summer dancing outfits that the Columbia Co. has so generously advertised. Dance records continue to be the main call in the Columbia record warehouses.

A distinguished visitor of the month was George W. Lyle, who came to the city on a short tour of inspection. Mr. Lyle is well satisfied with conditions generally and viewed the business situation with optimism.

C. E. Baer and his wife started for New York June 8, accompanied by Mr. and Mrs. Edward Blimke. They will motor the entire distance and will be gone about three weeks. While in the East the two Columbia men will visit the factory.

An All-Efficiency Office.

W. W. Parsons, local Dictaphone manager, has

made his office the ultimate in the matter of business efficiency by installing a Dictagraph outfit, whereby he may talk to or listen to any one of the other people in the office, or to all at once, without rising from his desk or even reaching out his hand for a telephone. The Dictagraph is similar to that made use of by many detective agencies, although much changed to meet the requirements of business institutions. It is very interesting to see Mr. Parsons at his desk dictating letters into a Dictaphone and directing the employes of the big offices at almost the same time. His is the all-efficiency office. Mr. Parsons reports that B. F. Swanson & Co., of Des Moines, Ia., and C. H. Rollins & Son, of Keokuk, Ia., are two new agents for the Dictaphone.

Mr. Herdman, manager of the St. Paul office of the Dictaphone Co. was a visitor to the local offices.

New Wurlitzer Man.

L. E. Noble is the new man in the wholesale talking machine department of Wurlitzer's, succeeding F. C. Harnden. Mr. Noble is a young man who has had extensive sales experience and under the direction of Assistant Manager Fred A. Siemon he is making such experience felt. Mr. Noble is devoting considerable time in the solution of dealers' problems and no doubt his ideas will prove to be of great value.

Special Summer Sales Plans.

Some very effective sales promoting plans designed to answer the requirements of summer conditions have been prepared by the Talking Machine Co. and are already being made heavy use of by numerous dealers. The immense call for Styles IV, VI and VIII to be used by vacationers in the woods and on the lakes suggested what the possibilities of the summer trade could amount to. Customers who have entered stores in answer to advertisements of summer and dancing outfits have been appealed to by the talking machine's wonderful possibilities for perhaps the first time and the result in many cases has been that the prospective buyer has left after ordering one of the larger machines. The buyer is easily impressed with the fact that the additional cost of a larger machine can soon be paid off and the result to buyer and seller is always most satisfactory.

The past month has shown good business for the Talking Machine Co., due in part to the replenished record stocks and to the generous purchases of Styles IX and X in fumed oak and the new Style X and XI machines.

(Continued on page 36.)

THE WADE—THE PRACTICAL—THE WADE Fibre Needle Cutter

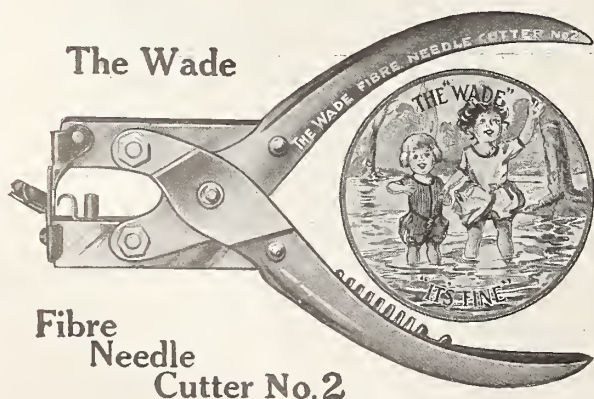

The WADE embodies the *right principle*, worked out through *long experience*. It is simple, durable and accurate. It trims the needle at an angle resulting in the best tone.

The WADE cutters are made of the best steel and are absolutely guaranteed.

The WADE is the most economical cutter. It has a self-acting stop, which prevents waste and enables one to get from 12 to 15 perfect playing points. No. 2 has a double action, making it especially easy to operate and affording the most powerful cut of any tool made. No. 1 is a very popular cutter which has given excellent service.

RETAIL PRICES—No. 1, \$1.50; No. 2, \$2.00

Order from your regular Distributor—we sell to Jobbers only

WADE & WADE,

3807 Lake Ave.
PHONE, DOUGLAS 8108
CHICAGO, ILL.

Two Successful Ideas

Lyon & Healy's Idea of the Victrola

From the very beginning we have advocated the highest and best in the handling of the Talking Machine proposition. We have always felt that its rightful place was in first-class surroundings. Dealers, whose conception of the business agrees with ours, can obtain many helpful hints from us. Write to us about your problems. We will tell you what we would do under similar circumstances.

LYON & HEALY
Victrola Distributors
CHICAGO



MORTON
©

Lyon & Healy's Idea of Service

Years ago we inaugurated so high a standard in taking care of the wants of dealers that many said we were aiming at the impossible. To-day our standard is higher than ever, but we have a host of imitators. Dealers will find EXTRAORDINARY ALERTNESS to be the keynote of our Victrola and Record business.

Send your orders to us and you will find that you will have strong co-operation. We have made a success of our own retail Victrola business and we can greatly help you by means of the unique Lyon & Healy Service to make a success of your business.

LYON & HEALY
Victrola Distributors
CHICAGO

LYON & HEALY
Victrola Distributors
CHICAGO

FROM OUR CHICAGO HEADQUARTERS—(Continued from page 34).

R. J. Keith, sales manager, recently made a short trip which included a stop at Indianapolis to witness the motor races. While there Mr. Keith was the guest of James Whitcomb Riley, the famous Hoosier poet, and together with Howard Chandler Christy, the illustrator; Mr. Johnson, owner of Century Magazine, and Carl Fisher, one of the owners of the speedway, enjoyed the courtesy of the judges' stand.

Increases and Improves the Tone Values.

A talking machine attachment has been invented and placed on the market by A. S. B. Little, of Nashville, Tenn., which is highly spoken of by those who have heard it. The object of this invention is to do away with the more or less destructive influences and effects of rigidly held needles on the records. In playing his records on his own machine Mr. Little noted the damage done and the imperfect renditions obtained by rigidly held needles and made and applied to his own machine the "Little One-der" attachment. This attachment can be used on any standard disc Victor or Columbia record on any standard machine. It cannot be used on the new Edison talking machine. The claim is made that it will play any record much better than a rigidly held needle, and while it improves the playing of new and perfect records and much prolongs their life, it is also stated most positively that by the use of the "Little One-der" records that have been discarded as useless because of some scratch or crack can be played anew. The use of the "Little One-der" necessitates no change in the machines or the needles. The price is low and it should prove a good seller with little pushing.

Notes and Visitors.

H. G. Power, manager of the talking machine department of the Taylor Carpet Co., was a visitor to the local trade.

L. C. Parker, manager of the piano and talking machine departments of Gimbel's, of Milwaukee, passed through the city on his way to the piano men's convention at New York.

Word has been received here that Mr. Haile, formerly with the Eggleston Music House at Champaign, Ill., is now with Geo. H. Wheelock, of South Bend, Ind.

John Green, a talking machine man of Grand Rapids, who is well-known to the local trade, is on a motoring trip to New York City.

Ike Kupfenberg, Milwaukee avenue Victor dealer, recently made an Eastern trip which included a visit to the Victor factories at Camden.

A. H. Forson & Son, of Austin, are the latest to establish a Victor department.

W. E. Ericson, Inc., are conducting a series of Victrola dancing exhibitions at its Evanston shop.

E. J. Melich has moved into new and larger quarters at 3938 West Twelfth street.

M. C. Conlin & Sons, Madison and Western avenues, have resumed business following a serious fire suffered recently. The shop has been remodeled and the stock much enlarged.

George Mickel, of Mickel Bros., Des Moines, Ia., called at the offices of the Talking Machine Co. on his way to Detroit, where he will spend a vacation.

The P. A. Starck Piano Co. attracted much business and attention recently with an elaborate "Queen of the Movies" window. The arrangement of photographs of the company and the prominence of the records displayed did much to produce a large sale.

News has come from Peoria that Mr. Kiess, formerly with the Wookey Co., is now the head of the new talking machine department of the Block & Kuhl department store.

P. H. Hughes, formerly with the Wisconsin Music House, of Janesville, Wis., has opened a piano and talking machine store at Oshkosh, Wis.

Some of the month's visiting dealers were: H. B. Eger, Libertyville, Ill.; B. A. Zechlin, Frankfort, Ill.; Mr. Willis, Mayview, Ill.; John Danlin, St. Charles, Ill., and S. L. Cook, Indiana Harbor, Ind.

Miss Theresa Dondero, for seven years in the local Columbia offices, will on June 24 become Mrs. Clarence O'Donnell. Best wishes.

J. B. Ryde has been appointed assistant manager of the wholesale talking machine department of Lyon & Healy. Mr. Ryde is one of the well-known

stand-bys of the house, having been with Lyon & Healy for the past sixteen years. He has covered the State of Illinois for the firm and is popular with the trade.

Congratulations are being offered Miss M. O. Tapper, of the wholesale talking machine department of Lyon & Healy, on her approaching marriage. The date has been set for June 27, and the name of the happy groom that is to be is R. E. Nordquist.

A. G. Nelson, manager of the Tri-City Piano Co., of Moline, Ill., has been a visitor, but found time to devote to something besides talking machines. He visited the races at Indianapolis, motor-ing with a party of friends from Chicago.

L. C. Wiswell, manager of the wholesale talking

more than ordinarily attractive, and Lyon & Healy offer a rare opportunity for Victor dealers to secure splendid publicity.

DEMAND FOR KLINGSOR NEEDLES.

Manager Reports Receipt of Twelve Million Needles of Various Styles with Twenty-five Million More in Transit.

(Special to The Talking Machine World.)

CHICAGO, ILL., June 9.—The American Klingsor Works has established offices in rooms 1316-18, North American building, under the management of Arthur Soudek, a man who is not only well acquainted with the needs of the American market, but who has also had extensive experience in the European trade.

Victrola
"The Ever-Ready Home Orchestra"

From \$15 to \$250
Easy Terms

DEALERS IMPRINT HERE

Come and hear the
New Models

New Lyon & Healy Poster.

machine department of Lyon & Healy, has been absent from the store for some days owing to a rather severe though not dangerous cold.

Henry Saak and A. G. Kunde, both of Milwaukee, were recent visitors to the local talking machine trade.

Nick Wurth, Columbia dealer of Escanaba, Mich., was one of the dealers who were in recently.

A New Lyon & Healy Poster.

A reduced fac-simile of the new Lyon & Healy Victrola poster is shown herewith. The great Chicago house is printing a number of these billboard posters for itself and it would be glad to run a few extra ones for Victor dealers in other cities. These will be supplied practically at cost to the Victor dealers.

Just now, when all the world is out of doors, these posters on principal billboards, and in towns adjacent to the dealer's place of business, will be

The popularity and growth of the demand for the Klingsor needles has been remarkable and a striking instance is afforded in Mr. Soudek's statement that he has just received a shipment of 12,000,000 needles of various styles and that another shipment of 25,000,000 is in transit. These needles can be used with the Victor, Edison and Columbia machines and are made in ten different styles adaptable to any variety of record.

A VISITOR FROM OMAHA.

A. J. Sanderson, Manager of the Edison Department of Hayden Bros. Speaks of Conditions in His City and Expresses Great Admiration for the Talking Machine World.

(Special to The Talking Machine World.)

CHICAGO, ILL., June 8.—A. J. Sanderson, manager of the big Edison department of Hayden Bros. Department Store, Sixteenth and Douglas streets,

"KLINGSOR" Talking Machine NEEDLES

(MADE IN GERMANY)

ARE THE BEST ON THE MARKET

10 STYLES

Write for Samples and Prices to the

AMERICAN KLINGSOR WORKS

1316-18 North American Building

CHICAGO

Omaha, Neb., is one of the first of the vacation-bent talking machine dealers to visit Chicago—the great central summer resort.

Mr. Sanderson came armed with all of the equipment of one determined upon having a good time, including a kodak wherewith to record the said good time for future reference.

Mr. Sanderson reported an excellent Edison year, saying that the past month's sales more than doubled those of the corresponding period of last year, and had the supply of goods been sufficient to supply the demand the record would have been

an even better one. "The larger Edison machines have been our long suit," said Mr. Sanderson. "They seem to sell easier than the cheaper grades.

"While I have the opportunity I want to tell you how much I appreciate The Talking Machine World. I receive copies both at my home and office and the minute The World comes I start to read it through. There is not a paragraph I do not see. I get something good out of it every month—things that give me a little more 'backbone' and a few more ideas. I think The World is the best thing that a man in this business can invest in."

and four days later the sale had to be called off until another order could be placed for additional stock.

There was no definite announcement as to the total of the sales, but it was understood they reached something like \$5,000 in the two weeks the sale ran.

One of the most important features of the plan, as it was found to work out, was a discount of 10 cents on each payment made in advance. The result of this offer was that a very large number of purchasers made several payments ahead at the time the machine was delivered. This insured the company against the person who might consider the plan an easy means to obtain a machine for a few weeks and then return it. The discount, carried through the entire course of payments, amounted to \$3.90, or nearly 10 per cent. As a matter of fact, many took advantage of discounts, running from \$2 to \$3.

It was reported, says Printers' Ink, that there were a few cases—less than a dozen—where purchasers had desired to return the machines after making two or three small payments, but in practically every case a little straight-from-the-shoulder talk convinced such purchasers that it would be better for them to keep the machines and pay for them. The discounts, however, in the hands of trained salespeople, minimized such troubles to a great extent.

THE SALES FORCE REFLECTS POLICY OF THE HOUSE.

Interesting Paper Read at Recent Convention of Indiana Piano Merchants' Association by Fred L. Paige, of Terre Haute, Which Possesses Many Points of Interest for Members of Retail Branch of Talking Machine Industry—Views of a Practical Man.

The employing of salesmen results from the desire on the part of the employer to do as much business as his capital warrants, and sometimes from his personal inability as a salesman or his lack of ambition in that direction. Whatever may be the reason the employing of salesmen seems to be a very necessary part of the piano business, and to get, make and keep good men is certainly one of the largest problems of the employer.

A salesman to be successful must have a personality, making for himself and his house hosts of friends, not only the real buyers, but the kind that will go out of their way to point out a real sale and help boost the making of it. He must first of all be absolutely honest, not only to his house, but to his customers also, and conscientiously give to them the value he has represented to them as giving. He must be ever and always on the job, alert and strenuously careful that his house has a hearing with every customer, if not a successful one. He must work ever with the aim of closing his sales to the best advantage as to terms, not being content with simply following the line of least resistance, and closing on the minimum terms, just because a customer thinks it to be to his advantage to make the terms low. He should use extreme care in the selection of his sales, yet exercise a judgment born of experience, and not be afraid to make a sale even if the payments are low, providing it can be safely made and at a sufficient profit to justify. He must be able to discriminate between the customer who pleads poverty and talks for low terms, when an investigation will show that there is absolutely no reason for his not paying even better terms than asked for.

A salesman should and I think usually does reflect the policy and business morals of the employer, and one brought up in a house of tricky tactics and immoral surroundings usually brings to his next job many bad habits hard to break. The selling of pianos should be on a plane with works of art and other artistic merchandise, but I am sorry to be compelled to admit that through the exploiting of ruthless money grabbers, not merchandise, it has in many sections fallen to the level of the despised sewing machine and lightning rod business. It is the mission of the best class of salesmen to raise the standard of the business, and this can be done only by a strict adherence to honest methods.

It has always been considered that salesmen are born not made, and while many are called, few are chosen. The gift of salesmanship seems to fall on few, and some do not recognize it early enough to get out of the kindergarten class, while others take up some line in which they are especially interested, and so thoroughly acquaint themselves with that line that with tact, persistence and persuasion, the average customer falls a willing victim and forever afterward sings his praise. Salesmen are employed under various forms of contract, their compensation depending on their ability to sell goods, to do a clean business and to maintain for their employer a reputation which admits of no criticism. While there are many in the trade whose qualifications along these lines fail to measure up as they should, there are still a limited number of those bright intelligent fellows particularly endowed with powers of argument and persuasion, and possessed of a keen sense of honor and morality, making them salesmen of whom a house may justly be proud.

Our experience with salesmen has been somewhat limited, as we have not hired promiscuously and have for the most part taken young men and educated them along the lines of our own methods and house policy. We have usually hired on the straight salary basis, feeling that with our one-price system and simple organization our interests are best served by this arrangement. We pay salaries ranging from \$12 per week up, and expect of a salesman sufficient business during a period of six months or a year to make the "salesman cost" from 15 to 19 per cent. While we must confess we fall short of this ideal and still retain the services of the man, it is because of the character of his business and his ability to make himself of service in many other ways outside of selling. I believe that there are many salesmen whose services are valuable to their employers who are not producers of high business.

The out-of-town business we find cannot be produced on as low a per cent. as the city business, and it is a grave question with us if the out-of-town business is at all profitable except as an advertisement and for its swelling the number of sales made and incidentally assisting the manufacturers to dispose of their stock. I believe the business has undergone some radical changes during the past few years, and in one way this is seen in the doing away by some houses of outside canvassers or the ringing of door bells, as it is commonly called, and the business of to-day is being brought in to the house more and more.

Business also has turned largely from the old methods of argument in which the salesmen depended almost entirely on the credulity of their customer and their own ability to so color the unbelievable as to make it appear a fact. The present day salesman must know his goods and be able to describe them so vividly as to make a catalog unnecessary. But, as before said, of much more importance is his personality and ability to inspire confidence both in himself and his house. The selling of pianos being specially a personal appeal, it is very difficult to lay down any absolute rules.

"PROGRESSIVE INSTALMENT PLAN"

Recently Introduced in Indianapolis Strikes a New Chord in This Line of Merchandising, Particulars of Which Will Interest Piano Men—Size of Payments Increase Steadily Until Goods Have Been Fully Paid For.

In view of the many forms of instalment sales that prevail in the music trade industry, it is interesting to note how this form of work is conducted in other lines—for instance, the sewing machine field. "The progressive instalment" plan recently inaugurated by L. S. Ayres & Co., of Indianapolis, will interest a great many in the piano field because of its novelty and rather ingenious means of attracting the attention of the public.

Ayres & Co. advertise the Standard Rotary sewing machine, on payments starting at 5 cents for the first week and increasing 5 cents a week until the total is paid, and is reported to have had excellent returns from the sale.

The price of the model so sold is \$39, and the payments on this basis extended over a period of thirty-nine weeks, the last payment being in the neighborhood of \$2.50. It is said that forty machines were sold the first day of the novel sale.

EDISON BANS CIGARETTES.

Workers Can't Use Them, Though He Smokes Cigars and Chews.

The 6,700 employes of the Edison shops in West Orange, N. J., the other day were confronted on every side with printed signs bearing this warning:

.....
: Cigarettes NOT TOLERATED. They :
: Dull the Brain. :
:.....

As a result of correspondence with Henry Ford, the Detroit automobile manufacturer, Thomas A. Edison decided to be a crusader against the cigarette. At the request of Mr. Ford Mr. Edison made an analysis of at least twenty brands of cigarettes. While he found the tobacco contained in them was of all qualities, he found poisonous matter in all the papers in which they were rolled. Said Mr. Edison:

"That poison attacks the brain and works havoc with a man's mental activity. His mind becomes clouded. Evaristo Madero, brother of the late President of Mexico, told here a few days ago that men, women and children are inveterate smokers of cigarettes in the Southern republic."

Mr. Edison has always abhorred cigarettes, but he is a heavy smoker of cigars, and he likes to chew tobacco.

SEND FOR SAMPLES

Patented.



Regular Model

De Luxe Model
(Patented)

Each in a box and every dozen in a display carton.

Retails for 50c each

"DUSTOFF" RECORD CLEANERS

Add life to records. Keep the tone pure and clear. Get into the minute sound grooves of the record and thoroughly remove all accumulated dust and dirt.

CLEAN ALL MAKES OF RECORDS

Distributed by most Victor and Edison Jobbers and all Columbia distributors.

SAMPLES Sent postpaid, on approval, if you write on your business stationery giving jobber's name.

Every dozen in a counter display carton.
Retails for 15c. each.



MINUTE SHINE CO.
189 Canal Street Providence, R. I.

ADVERTISING SCHEMES THAT INCLUDE PRIZES

Which Are Dependent Wholly or in Part Upon Chance, Stand a Poor Show at the Post Office Department These Days—Interesting Information on This Subject Submitted For Benefit of Readers of Talking Machine World—What Is and What Is Not Affected.

Advertising schemes that offer prizes dependent wholly or in part upon lot or chance stand a poor show at the Post Office Department these days. The use of the United States mails for the promotion of lotteries is, as is well known, prohibited, but it is not so generally realized that the Department is little, if any, more lenient toward certain prize schemes, gift enterprises and guessing contests. This policy has an especial significance for advertisers since the recent revival by the Postmaster-General of the practice of issuing fraud orders against offenders pending the disposition of the cases in the courts. This method has, of course, the effect of shutting off an advertiser's mail without waiting for the courts to pass upon the case.

In a recent report to the Postmaster-General, the assistant attorney-general for the Post Office Department declares that a very voluminous correspondence between his office and postmasters throughout the country is necessary in connection with the enforcement of the statute which declares unmailable all letters, cards, circulars, certificates and other matter concerning lotteries and gift enterprises.

Outlining his policy in such cases, the law officer of the Department says:

"Postmasters throughout the country make requests daily for rulings from this office upon the mailability of matter handled by them relating to every conceivable kind of contest contemplating the award of prizes of one nature or another. Many of the enterprises, such as 'guessing' or 'estimating' contests, certain classes of prize card-parties, contests in which prizes are to be distributed according to the priority of receipt of the answers, prize-package schemes, all drawings, raffles, etc., also 'endless-chain' enterprises designed for the sale or disposition of merchandise or other things of value through the circulation or distribution of 'coupons,' 'tickets,' 'certificates,' 'introductions,' 'contracts' and the like, which are as well inherently fraudulent, are invariably held to be embraced in the terms 'lottery, gift enterprise, or similar schemes offering prizes dependent, in whole or in part, upon lot or chance' as used in the postal lottery statutes; and in the administration of these laws postmasters and other postal officials are instructed as occasion arises to with-

draw from the mails all publications, circulars, cards, pamphlets and other matter containing advertisements or notices or other information of any kind concerning such schemes.

Window Displays Affected.

"There are also presented numerous other propositions which may not in themselves be in violation of the lottery statutes but which, when first submitted, usually embrace some features rendering them unmailable under the law in question. They include such enterprises as those involving the offer of prizes for the most votes secured in newspaper subscription and other contests, for the correct, or nearest correct, solutions of puzzles, problems, etc., and for the supplying of words, letters, or sentences missing from published matter; for the best window displays of different articles; for the best names to be used for various purposes; the best essays, compositions, productions, etc.; also some in which are involved the distribution of lots or tracts of land in town-site and other land-openings, etc. When the objectionable features are eliminated and certain required conditions incorporated in such of these contests as admit of reformation, the matter is allowed admission to the mails."

For advertisers, the significance of this pronouncement is found in the final sentence wherein there is seemingly indicated the willingness of the Department to pass in advance upon the mailability of advertising matter relative to schemes and contests of one kind or another. Presumably, to be sure, the matter must be submitted through the advertiser's local postmaster, but the important point is that the matter can be referred direct to headquarters with the presumption that an advertiser can obtain an authoritative opinion on his copy ere he has gone to the expense of printing and posting his literature.

In short, this is much the same sort of advance advisory policy which has been adopted by other departments, with reference to manufacturers' labels on food and drug products. And in the case of the Post Office Department, says Printers' Ink, such a policy is assuredly in marked and gratifying contrast to the policy which has obtained at certain stages in the past when the officials of the division of classification and others in authority were wont to refuse to give any advice to an ad-

vertiser or to intimate what their decision would be with reference to any submitted piece of advertising literature. They took the absurd position that an advertiser must "put his head in the noose" by actually mailing the matter regarding the status of which he was in doubt, ere the Department would give any indication whether or not such matter was deemed to be clearly in violation of law.

COLUMBIA LINE FOR WESER BROS.

Prominent Piano Concern to Handle Grafophones and Records in Retail Stores.

The Columbia Graphophone Co. closed arrangements recently with Weser Bros., 131 West Twenty-third street, New York, whereby this well-known piano house will handle a complete line of Columbia products in its warerooms at this address. Weser Bros. are well-known in the piano industry, as their pianos and player-pianos are handled by representative dealers from coast to coast. Their warerooms on Twenty-third street are very successful, and Columbia machines and records will undoubtedly meet with a ready sale there.

PICTURES FOR DELINQUENTS.

Wilson E. Rickert, of Allentown, Pa., has devised a new series of collection pictures which have



COPYRIGHT 1914 WILSON E. RICKERT ALLENTOWN, PA.

been particularly useful in attaching to invoices to delinquents. It has been found to be a successful and diplomatic way of getting in money. Mr.



COPYRIGHT 1914 WILSON E. RICKERT ALLENTOWN, PA.

Rickert has a number of designs besides those attached, concerning which he will be glad to send full particulars.

NEW CONCERN IN BUTTE, MONT.

(Special to The Talking Machine World.)

BUTTE, MONT., June 6.—Joseph Lutey and L. V. Williams, of this city, have just opened a new talking machine store under the name of the Butte Phonograph Co., and will handle nothing but talking machines and records. The new quarters are fitted up in first-class style, there being three large soundproof demonstration rooms, with attractive furnishings and decorations. A complete line of Edison products will be carried in the new store, and George A. Renner, Northwestern representative of Thomas A. Edison, Inc., directed the arrangement of the store and the selection of stock. He will also assist the company in staging demonstrations for the next few months.

PRAISES DANCE RECORDS.

The Columbia Co. received this week an interesting letter from the Georgia Brown Dramatic School of Art, Kansas City, Mo., relative to the merits of Columbia dance records. This school is one of the best known institutions of its kind in Kansas City, and has numbered among its pupils many well known Middle West actors. The letter reads as follows:

"I wish to extend my congratulations to the Columbia Graphophone Co. upon the splendid records for dancing which I am using in my school. My pupils enjoy the perfect dance time and superior quality of music. Columbia records are beyond doubt a joy forever. Very truly yours, (Signed) Mrs. Georgia Brown."

LONG CABINETS

HAVE MANY FRIENDS

D 67, D 62, D 32 are now furnished
in FUMED OAK finish

Write for Circulars of
RECORD CABINETS
and
PLAYER ROLL CABINETS

The Geo. A. Long Cabinet Co.

Address all trade communications to

Clement Beecroft, Sales Manager

309 W. Susquehanna Avenue
PHILADELPHIA, PA.

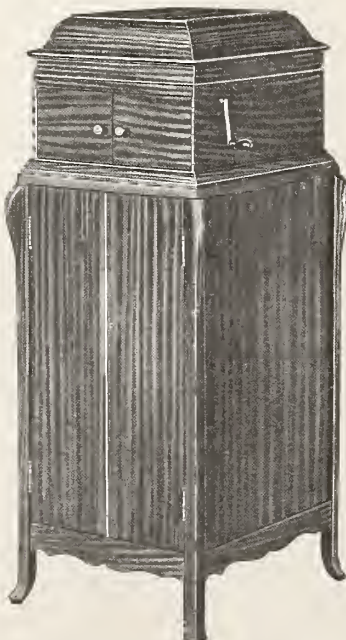

D 67

Mahogany, Fumed Oak, G. O. and W. O.
Sliding Record Shelf. For IX Victrolas,
Capacity, 192 12-in. records.

WEBB TELLS HOW HIS "TALKIE-MOVIES" WORK.

Interesting Personality of George R. Webb, Who Is Giving His Attention to Synchronization of Talking Machine and Film—While a Capitalist and Organizer, He Also Possesses a Mechanical Turn—How Investigation Was Conceived and Obstacles Overcome.

George R. Webb, whose "talkie-movies" are being shown here for the first time in the Fulton Theater, isn't at all the usual type of showman. Mr. Webb is rather a capitalist, an organizer, with a mechanical turn. Before he became interested in the synchronization of the talking machine and the film he was a railroad man, a telephone man and a dozen other things.

His first venture into a field remotely resembling his present one was the installation in Wilmington of a system by which telephone subscribers might be able to hear music in their homes, music which was produced by a talking machine at "central" and carried over the wires to the subscriber. The plan is still in operation.

His Friends Scoffed.

The step from this to the synchronization of the record and the film was a short one. Mr. Webb, telling of his work, said that when he first conceived it and told of it, his friends laughed and told him he was in his dotage.

"The trouble with them was," said Webb, "that they didn't realize, as I did, that the motion picture was to be the popular amusement of the future, and that a fortune awaited the man who made even the most unimportant improvements in its manufacture.

"Most persons have seen the crude earlier attempts to harness the talking machine and the cinematograph, which from time to time have made their appearance in this city. They were never satisfactory. It seemed, in the first place, that the "talker" was always a talking machine and the motion picture always a motion picture, and that when even the nearest approach to perfect synchronization was made the task of believing that the picture on the screen was actually talking or singing was too much for the most agile imagination.

"I had seen this trouble, too, and had noticed further that the power of a single talking machine was all too slight for use in a large hall.

Utilizes Electricity.

"I thought of coupling up a half a dozen talking machines, but I realized how impossible it would be to keep them all together. After casting about for months I suddenly thought of the telephone. Why not use the electrical current for carrying the sound from a single record to half a dozen horns? By such multiplication I could be sure of a sufficiency of sound, and of a complete unison between the horns. That, briefly, is the plan I have adopted.

"Of course, that is the merest outline. There are a hundred details. You will want to know, for instance, how I can have talking machine records of the voices of Caruso or Farrar singing to the motions of persons who are evidently not Caruso and Farrar.

"Well, I begin with a Caruso record. I play that record half a dozen times, or a dozen times, if necessary, before the person who is going to act for the camera, until he is entirely familiar with the tempo, the enunciation, the breathing and all such technical details. When he is letter perfect I put the record on a talking machine which is electrically connected with the motion picture camera. I start the record and the projecting apparatus at the same time, and the person whose picture is being taken sings in entire unison with the original record. It so happens then, as you will see, that I have a motion picture film of a man or a woman singing exactly the words on the record.

Only One Talking Machine.

"When the time for the show comes I simply start the record and the projecting apparatus at the same time. There is only one talking machine, remember, which is directly connected with the lantern.

"From this talking machine run wires to half a dozen horns arranged around the screen on which the picture is connected. Each one of these horns has a reproducing apparatus similar to the receiver in the telephone, only so sensitized that instead of giving forth a mere whisper, as the telephone does, it magnifies the sound to the power of the original.

"The operator turns the crank. The film starts, and the music starts with it. If the start is right, anything less than perfect synchronization is impossible. The audience looks at the singer pronouncing his words, or the banjoist fingering his stops, and they hear the sounds at the same instant the mouth forms the requisite consonant. It sounds complicated, but the principle is simple."

SECURES VERDICT.

Architect Recovers \$600 for Plans Drawn for Vitaphone Co.

Philip Raque, a Jersey City architect, was awarded \$600 by a jury in Judge Speer's court with interest from January 1, 1913, in his suit to recover compensation for professional services rendered to the Vitaphone Co., of New York.

The plaintiff had drawn up plans for buildings to be erected in Plainfield.

Frederick Colton represented Mr. Raque and Neison Runyon appeared for the defendant company.—Hudson Dispatch, June 9.

VISITED THE SOUTH.

V. W. Moody, sales manager of the New York Talking Machine Co., 81 Chambers street, New York, Victor distributor, spent the Decoration Day week-end in a visit to Old Point Comfort, Norfolk and Richmond, Va.

JOAN SAWYER WITH COLUMBIA CO.

Well-Known Conductor of Persian Garden Arranges to Supervise the Making of a Special Series of Dance Records for the Columbia Graphophone Co.—A Columbia Enthusiast.

The Columbia Graphophone Co. announced recently that it had closed a deal with Joan Sawyer whereby this well-known artist would supervise the production of several series of special dance records for the Columbia library. Miss Sawyer has already supervised the recording of one of these series by the Joan Sawyer Persian Garden Orchestra and these records are now being sent out to the trade. Joan Sawyer conducts the Persian Garden at 50th street and Broadway, New York, and is one of the best-known exponents of the modern dances in the country, having been markedly successful with her magnificent Persian Garden. Miss Sawyer, who will leave shortly for an extended tour of the country, accompanied by her orchestra, speaks in the following terms of Columbia dance records:

"I think it is only fair that having found Columbia dance records so immeasurably superior to all others, I should write you a line in appreciation of your successful endeavors to supply the dancing public with the very best in dance music that can be possibly had. Personally I am so impressed with Columbia dance recording that I have decided to have you make records for me of the dances I have been using in my own work and shall loan you for the purpose my special dance orchestra from the Persian Garden, New York. I look for some unusually interesting and excellent results. Believe me, Sincerely yours (Signed) Joan Sawyer."

ON TRIP THROUGH THE WEST.

Dan W. Moor Calling on Trade for Standard Gramophone Appliance Co.'s Specialties—New Record Cleaner Popular with Dealers.

Dan W. Moor, road ambassador for the Standard Gramophone Appliance Co., 173 Lafayette street, New York, is at present in the West on an extended trip that will include visits to all the leading trade centers. Mr. Moor will return the early part of next month in order to be on hand for the annual jobbers' convention, which will be held this year at Atlantic City, N. J.

"We are greatly pleased at the heavy demand for our new 'Standard' record cleaner," said Thomas W. Kirkman, manager of the company, in a chat with The World. "Although this cleaner has been on the market but a few weeks we are already receiving repeat orders, and Mr. Moor, our road ambassador, is booking gross orders from all the leading jobbers. The convenient form of our cleaner, coupled with its artistic appearance, combine to make it an accessory of unusual value and sales possibilities. The call for our 'Standard' fibre needle cutter also keeps up very strong, and at the present time we are working to full capacity to handle the orders of our patrons for this cutter."

All the music—and nothing else.

Our slogan: "Please thy neighbor as well as thyself."

Modify and clarify the music. Play old favorite records now discarded because of the scratches.

Agents Wanted.

You must act quickly to secure territory.

PATENTED MAY, 1914. By A. S. B. LITTLE

THE "LITTLE ONE-DER" ATTACHMENT



THE LITTLE ONE-DER CO., Calvin Ave., Nashville, Tennessee

It fits Victor and Columbia Machines and Records.

Place it in the needle-holder and insert needle in the orifice.

Uses standard needles.

Eliminates the scratch and scrape noises in new or old records.

Retails for \$1.00.

Low prices to dealers in lots of fifty.

Get literature and send for sample.

ANNUAL OUTING OF BLACKMAN CO.'S EMPLOYEES

Which Occurred on June 6, Most Enjoyable in Every Way—Sports of All Kinds Part of the Program—Annual Distribution of Dividends a Feature of the Outing—Entire Party Attends Palace Theater in the Evening—Sales Force Wins Ball Game.

June 6 was a red letter day for the employes of the Blackman Talking Machine Co., 97 Chambers street, New York, Victor and Edison cylinder distributor, as it marked the holding of the fifth annual outing and banquet tendered to the employes by the company. For the first time in these



The Winning Nine. J. N. Blackman Standing Second from Left.

five years the day scheduled for the Blackman outing was an ideal one, the four previous outings having been marred by rains and thunderstorms. Needless to say, the employes, together with the officers of the company and a few invited guests, determined to take full advantage of the blue skies and tempting sunshine, and it was a happy party of 35 that left the Blackman warehouses at 12:15, bound for Whitestone Landing, on the Sound, where the 1914 outing was scheduled to take place.

By special arrangement with the Long Island Railroad, a special car had been ordered, and this car left the Pennsylvania Terminal at 1:20, bringing the party to Whitestone Landing about 2 p. m. A varied program of games had been prepared for the early afternoon amusement, and at 2:15 the first race was called.

This race, which was termed a shoe race for men, was won by J. B. McGovern, with John Mills a close second. A 440-yard relay race between the office and sales forces and the shipping room force was next on the program, and after a nip and tuck struggle, the office and sales force team was returned the victor; the winning team consisting of President J. Newcomb Blackman, J. B. McGovern, L. W. Bishop and F. R. Burnham, Jr. A potato race for ladies furnished general amusement, Miss Hattie Ott being returned the victor, with Miss M. Hennig second and Miss C. A. Pratt third. This order of finishing also held good for the 50-yard dash for ladies, which was on the program later in the afternoon.

The 220-yard dash for men resulted in a neck



Frank Roberts and a Bevy of "Fanesses."

and neck finish between L. W. Bishop and John Hanley, the former winning on the last few strides, with Albert M. Blackman, son of President Blackman, a good third. The next event, the running broad jump, proved the star event of the afternoon's games, as it brought out some splendid jumps and keen competition. L. W. Bishop of the

sales force, who had distinguished himself in various other capacities in the earlier part of the program, also won this event with the remarkably good jump of 16 feet, which is "some" jump for the average amateur performer. John Hanley finished second and J. B. McGovern third. A 150-yard relay race for stout people (two men and two women) was won by Miss L. Peters and George Thaw, after an exciting race between the two ladies. The ladies then held a five-frame bowling contest, which was captured by Mrs. M. G. Smith, with Mrs. George Thaw second and Mrs. John Spillane third.

The entire party then adjourned to the ball-field, where the main event of the day's entertainment, in the nature of a ball game between the shipping room and the office and sales force, took place. Interest in this game was at fever heat, as the rivalry between the two forces was intense, and good natured bantering as to the probable result had been going on for a fortnight prior to the game.

The teams lined up as follows: Office and sales force nine—Albert M. Blackman, shortstop; J. B. McGovern, 2d base; F. R. Burnham, Jr., 3d base; J. Newcomb Blackman, 1st base; J. F. Ashby, centerfield; John Spillane, right field; Charles Reinhart, left field; L. W. Bishop, pitcher; R. B. Caldwell, catcher. Shipping room nine—Edward Steinecker, 3d base; John Mills, shortstop; John Hanley, catcher; Charles Krauss, 2d base; A. G. Camerano, 1st base; Robert Harkins, left field; C. W. Cornwall, right field; Charles Marquis, center field; George Thaw, pitcher.



J. N. Blackman Fouling Off a Good One.

The game itself was unusually close and well played, and although it had been freely predicted that the shipping room team would be the winners by a one-sided score, a big surprise was in store for the entire party, as the office and sales force team was returned the winner after an exciting tussle by the score of three to two, regular major league figures.

Vice-President Caldwell sent in the winning run in the second inning when his two-bagger sent two runs across the plate, breaking the tie score. President Blackman, on 1st base, fielded his position in topnotch form, and let nothing get away from him. Albert Blackman at short and J. B. McGovern at 2d base were also prominent in the office nine's victory,

while L. W. Bishop pitched air-tight ball after the second inning. For the losers George Thaw is deserving of special mention, as his control was perfect, and his speed baffling. A. G. Camerano at 1st base covered a lot of ground, and was also there with the "willow." The game as a whole was well worth seeing, and was thoroughly enjoyed

by all the spectators. F. R. Burnham umpired a fair, impartial game, judging the balls and strikes with the precision of a league arbiter.

After the ball game excitement had subdued the party adjourned to Duer's Hotel, where an elaborate Long Island shore dinner was served, amidst continual laughter and good cheer. This dinner was typical of Long Island culinary achievements, and formed a fitting finale for the afternoon's fun. A feature of the dinner was the distribution of humorous and appropriate postcards, together with trick souvenirs that kept the table in an uproar. A few of the more timorous ladies refused to eat their asparagus because of the appearance of monster beetles thereon, which on closer investigation proved to be made of colored paper. Score one for practical jokers J. Newcomb Blackman and R. B. Caldwell.

At 7:16 the Blackman party boarded their special car for New York, en route to the "Palace"



Shipping Room Team.

Theatre, the city's leading vaudeville show-place. While en route to New York, President Blackman announced the annual distribution of dividends which always takes place at the yearly outings. Mr. Blackman believes in the policy of permitting his employes to share the profits of his business with him, and the efficiency of the Blackman organization is a tribute to his generous policies and liberal methods. Every employe who has been connected with the company for a year or more is entitled to a share in the dividends, and whereas there were fourteen participants last year, this year there were sixteen. The first one to receive a dividend was Frank Roberts, the veteran of the Blackman forces, and personally known to every Blackman dealer on the books. Following Mr. Roberts, dividends were handed to the following



R. B. Caldwell in His "Armor."

members of the Blackman staff: John Spillane, J. F. Ashby, A. G. Camerano, Charles Reinhart, L. W. Bishop, Miss L. Peters, H. C. Lansell, Miss M. V. Ward, Robert Harkins, George Thaw, Miss



Our forty-two distributing centers are ready to supply you promptly with the biggest dividend diggers in the trade today—including the very latest in dance music.



(Write for "Music Money," a book "full of meat" for those dealers interested in quick and frequent turnover of capital.)

Columbia Graphophone Company
Woolworth Building, New York

H. Ott, F. R. Burnham, Jr., C. W. Cornwall, Miss M. Hennig.

At the Palace a splendid bill was all that was needed to make the day a long-to-be remembered one, and at the close of the performance, Mr. Blackman was given a hearty vote of thanks by all present for the thoroughly enjoyable day that they had passed as guests of the Blackman Talking Machine Co. These guests included the wives of the officers and staff, while Mrs. Ada L. Blackman, secretary of the company, was an important factor in the entertainment of the ladies.

As indicative of the modern trend of co-operation and liberal attitude towards employes, the annual Blackman outings are in the right direction of progress and humane ideas as applied to mercantile life. The loyalty of the Blackman forces and the efficiency of the entire staff is but the outward sign of the results that these outings are achieving, while the good-fellowship and bon camaraderie that exists among the Blackman employes the year round is another tribute to the broad policies of its president and officers.

NEW VICTROLA MODEL PLEASURES.

New Victrola XI "F" Delights Visitors to the Showrooms of New York Talking Machine Co., New York—Great Success Predicted.

The New York Talking Machine Co., 81 Chambers street, New York, Victor distributor, is displaying in its show window one of the first models to be seen in the local trade of the new Victrola XI, type "F," which, as announced in a recent issue of *The World*, embodies certain distinctive refinements which should insure its popularity with Victor dealers throughout the country.

V. W. Moody, sales manager of the company, states that every dealer who has visited the showrooms during the past month is enthusiastic over the artistic appearance of this new \$100 Victrola, and they all predict that it will be favorably received throughout the country. The new arrangement in this model whereby the records may be filed horizontally instead of vertically, as heretofore, is praised by the trade as being a decidedly valuable selling argument.

POLLACK IN NEW QUARTERS.

Well-Known Talking Machine Dealer of Poughkeepsie Locates in Heart of Business Section of That City—Handles the Columbia Line.

(Special to *The Talking Machine World*.)

POUGHKEEPSIE, N. Y., June 8.—S. Pollack, the well-known talking machine dealer of this city, has just moved into new quarters at 209 Main street, the leading business street in Poughkeepsie. Mr. Pollack formerly occupied a store at 2 Garden street, but his rapidly increasing trade made it necessary for him to secure more pretentious quarters. The store at 209 Main street is a large and attractive one, and is furnished in a tasteful manner. Mr. Pollack handles the Columbia line exclusively, making a specialty of foreign record business.

Second thoughts are best, when they are less expensive.

"TALKERS" FOR JOHN SHILLITO CO.

Prominent Talking Machine Store to Add This Line—Drabelle Opens Grafonola Department in Dine's Furniture House—Victor Business with the Leading Stores Very Active—Manager Whelen of Columbia Headquarters Optimistic Over Trade Outlook.

(Special to *The Talking Machine World*.)

CINCINNATI, O., June 4.—One of the real surprises of the past month was the resignation of Harry B. Drabelle from the Victor department of the Rudolph Wurlitzer Co., and his blossoming forth as the manager of the Grafonola department of Dine's Furniture House, 1123 and 1125 Main street.

The move therefore is of double interest to the trade, since it means that the Columbia folks have opened another local outlet for their business and Drabelle is in charge of the department. Drabelle was supposed to be one of the fixtures at the Wurlitzer store. He has quite a following about town.

The John Shillito Co. will soon take on a talking machine line. Overtures are now being made with the different companies. The exact status cannot be learned at this time. It appears to be a question as to how the manufacturer or the jobber is willing to place his goods there.

Generally speaking, business is somewhat quiet. The dealers are featuring the smaller instruments in order to attract the attention of the campers, and in some respects have been quite successful.

Manager Whelen, of the local Columbia store, seemed to be very optimistic about the general outlook. He said, "I cannot complain, as the final wind-up in May showed an increase over last year and the prospects for a lively summer business look good. The first part of May started out very brisk, but toward the latter part of the month there seemed to be a "dropping off," but June has been holding its own very nicely. We give the "dance craze," which continues to hold a foremost place in the minds of the general public, credit for a large part of the summer "boom" in our line, and

also the popularity of the Grafonola for summer cottages and camps. This, of course, creates a demand for the smaller machines, although the demand for the larger machines continues to hold its own."

Mr. Whelen further stated that the wholesale business throughout the entire territory seemed to be holding its own, with the exception of the dealers in the milling districts, where they depend on the mill hands to stimulate business.

Clifford Ely, special traveling representative of the Columbia Co. was in the Cincinnati store for a few days, stopping over on his way to New York.

Ben L. Brown, who has been concentrating his efforts on the school proposition this winter, seems to be perfectly satisfied with the net results, and when asked about conditions, said: "There is no doubt in my mind but the time is coming and coming fast, when Columbia Grafonolas and records will be part of the legitimate equipment of every public school in the country."

Victor business at Aeolian Hall has been very satisfactory the past month, both in machines and records. The demand for dance music continues active. A great many Victrola owners arranged to have their machines packed up and shipped to their summer homes—more, in fact, than in any previous season at the same date. This is due, largely, it is thought, to the interest in dancing and plans for home dances during the heated term.

A number of sales of the lower-priced Victrolas have been made, due, no doubt, to the Aeolian Co., featuring the light-weight, easy-to-carry styles in their newspaper advertising.

One of the most attractive Victrola window displays seen in a long while was gotten up for Decoration Day. It showed a camp scene with a Style VI Victrola placed on a tree stump. All the details were carefully worked out and the window attracted a great deal of favorable notice.

Watch the new customers and cultivate their acquaintance, for they sometimes turn out to be the best customers.

Perfect In Every Detail

As artistic, compact, and powerful as this illustration suggests.

Thousands of satisfied users signify surpassing excellence and substantial profits.



Send 50 cents in stamps for sample. Write on your business letter-head only. Place regular orders through your jobber.

STANDARD GRAMAPHONE APPLIANCE CO.

173 LAFAYETTE STREET,

NEW YORK

PITTSBURGH A LIVELY CENTER.

Frederick Co. Opens Talking Machine Store at Woodlawn—Kaufmann Bros.' New Auditorium—Busy Month with Buehn—Columbia Store Being Remodeled—Most Attractively Arranged—News of the Month.

(Special to The Talking Machine World.)

PITTSBURGH, PA., June 10.—The W. F. Frederick Piano Co., on June 1, opened a talking machine store at Woodlawn, Pa., where the Victor line is being handled exclusively as at the Pittsburgh headquarters. During the past few weeks the W. F. Frederick Co. has given over one of its large Smithfield street windows to a Victrola camp outfit display in which a typical camp scene is depicted. The Victrola is shown in use with the shipping box used as a cabinet. It is this feature of the outfit that makes it particularly adaptable for outing purposes.

The Kaufmann Bros. Victrola department during the past month has been brought to a point that approaches perfection in every particular. The new auditorium, in which Victrola recitals will be given from time to time, is being rushed to completion and will be open to the public within the next few weeks. The decorators are now at work finishing the interior in gold and terra cotta, which sets off the weathered oak woodwork to an excellent advantage. Manager H. N. Rudderow reports that the Victrola department is doing a splendid business for this season of the year and that two men have been assigned to outside sales work. There has also been a marked improvement in record sales during the past few weeks.

The Schroeder Piano Co. opened its new talking machine department about May 18 and reports an exceptionally fine business from the start. A full line of Grafonolas is being carried, as well as a complete stock of records costing \$7,000. Six up-to-date booths have been installed on the first and second floors, and the arrangement is one of attractiveness and convenience throughout. The opening of the department was most auspicious, as fifteen machines were sold on the first two days. Miss H. R. Dunn, formerly of the McCreery department is in charge.

A. A. Buehn, of the Buehn Phonograph Co., reports that the month of June has started off very briskly and promises to be much better than May. The company has recently added to its list of dealers handling its line the Edison, Clyde Ament at Apollo, Pa., and the Poling Music Co. at Elton, W. Va. Both of these carry the disc line. Mr. Buehn, in discussing the present condition of business, said that the improvement noted during the past few weeks is due largely to the fact that the railroads are putting on more men and that if the mines resume their operations to a greater extent trade will continue to improve.

J. C. Roush, of the Standard Talking Machine Co., declares that trade is as good as can be expected at this season of the year and is considerably better than at this time last year.

George S. Hards and French Nestor, of the W. F. Frederick Co., and J. C. Roush, of the Standard

Talking Machine Co., will be among those who will attend the jobbers' convention.

The Pittsburgh branch of the Columbia Graphophone Co. has reopened its store at Sixth street and Duquesne Way after remodeling it into one of the finest in the city. Within the past two weeks the entire stock has been transferred from the second floor of the Fulton building, where temporary quarters had been occupied, into the company's new home. The office force has also moved its quarters from the Bessemer building onto the new mezzanine which has been erected in the rear of the store. In point of appearance and equipment there are few talking machine stores that can rival the new Pittsburgh home of the Columbia. A brisk business is being carried on and, in spite of the inconvenience experienced by the fire which occurred the first of the year, the branch has lost little time.

THE VALUE OF COURTESY.

How Business Establishments May Be Materially Aided.

Business is frequently turned away from many business establishments through lack of courtesy on the part of someone connected with the establishment.

Some railways in this country have built up an enormous patronage and made millions of dollars by a policy of helpfulness and courtesy by their employes to their patrons, while some parallel roads have been unsuccessful and have gone into the hands of a receiver largely because of the lack of courtesy, kindness and obligingness of their employes. Courtesy pays in every business institution. Human nature is so constituted that people will often put themselves to great inconvenience, will even put up with an inferior article or with discomforts, rather than patronize houses that treat their customers rudely. Courtesy is to business and society what oil is to machinery. It makes things run smoothly, for it eliminates the jar and friction and the nerve-racking. The officers of a bank, for instance, know that they must win and hold the favor of the public or go to the wall. They know that they cannot snub their customers to-day as they once would when there were fewer banks, without losing business. With a score of banks soliciting his business and offering every possible inducement to secure it, it does not require a very keen insight into human nature to know that, other things being equal, the business man will patronize the bank that has the most pleasing, the most agreeable officers and clerks. It is human nature to like to be treated with courtesy, with consideration. Bank officials often wonder why Mr. So-and-So has withdrawn his patronage, and they will probably never know that it turned upon a hasty remark of a teller, a little disposition on the part of some petty official to be unaccommodating. On the other hand, men often go out of their way in order to deposit at a bank where the cashier or tellers have been kind to them and have always shown a disposition to accommodate. A successful business man has tried to impress this idea upon the minds of his force: "Always think of what the cus-

tomers will say when he gets out of the store." Competition has become so keen and the bid for public patronage so insistent that it is a matter of first importance for the business institution which would succeed to-day to be popular to have the good will of its patrons.

TRIBUTE TO ADOLPH GLENN.

One of the Noble Silent Workers in the Trade Field in Portland.

(Special to The Talking Machine World.)

PORTLAND, Ore., June 1.—Henry Eilers, founder and head of the Eilers Music Co., was a great admirer of the late Adolph Glenn, manager of the Columbia Graphophone Co. interests in this city. Mr. Eilers says: "He was one of the silent workers of the trade, doing big things in a big but quiet way; beloved by all with whom he came in contact, a good man whose purposes and aims were high, whose tongue was gentle and whose life was clean and who deserves this little tribute from his friends and business associates throughout the States."

TO RESTRICT USE OF SOUNDBOXES.

Victor Talking Machine Co. Prohibits Use of Victor Soundboxes or Connections on Other Machines—Customer Must Sign Agreement.

The Victor Talking Machine Co. sent out a letter to its trade recently, wherein it prohibited the use of Victor soundboxes in connection with any other talking machine. This letter enclosed a Victor soundbox certificate, which is to be signed by the customer who desires to replace or secure a new Victor soundbox. The order for the extra soundbox in the future from dealer to distributor or from the distributor to the Victor Talking Machine Co. must be accompanied by this certificate, which reads as follows:

"Fully understanding that the Victor Talking Machine Co.'s patented soundboxes are licensed for use only in connection with Victor talking machines and Victor records, I,, of, certify that I have in my possession a Victor talking machine, style, serial number, type, and agree that the Victor soundbox, style, serial number, will be used only on the Victor talking machine named above. (Signature of purchaser.)"

"I,, of, a regularly licensed dealer in the Victor Talking Machine Co.'s products, have witnessed the signature attached hereto, and have satisfied myself that the soundbox also enumerated is to be used only on the said Victor talking machine. (Signature of dealer.)"

REMOVE TO NEW QUARTERS.

Parks & Weiss, a well-known advertising agency handling among other accounts that of the Pathe-scope, Aeolian Hall, New York, moved this month from 141 West Thirty-sixth street to 56 West Forty-fifth street, New York.

TRITON MOTORS

Spring may be replaced within a few seconds.

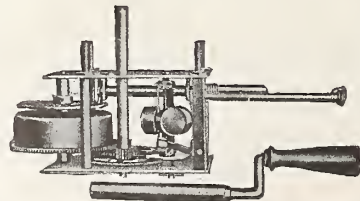

Noiseless Movements
Simplicity—Perfection

Can be wound while instrument is playing.

Quantity Price 75c., F. O. B. N. Y.

TRITON PHONOGRAPH CO.

41 UNION SQUARE, NEW YORK

Samples SENT UPON REQUEST \$1.25 EACH, CHECK WITH ORDER

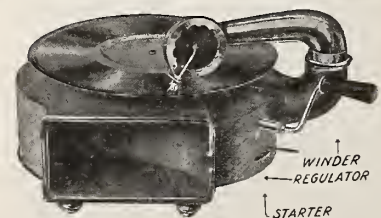

The Triton Phonograph
Retail at \$10.00

This machine gives you a chance to make a lot of money. Plays any needle disc record. Solidly built. Beautiful tone. Send for wholesale prices. Sample \$10.00.

TRADE CONTINUES VERY ACTIVE IN MILWAUKEE.

Summer Resort Trade Makes Its Appearance Earlier Than Usual—Miss Gertrude F. Gannon Married—Flanner-Hafsoos House Adds New Parlors—Effective Columbia Publicity—Affairs of Goodale—Large Victor Trade at Gimbels—New Edison Disc Dealers.

(Special to The Talking Machine World.)

MILWAUKEE, WIS., June 9.—The retail talking machine business is holding up well, considering the dulness which is being experienced in some lines of trade. While sales are beginning to fall off somewhat, the total volume of business is very satisfactory. Record sales have been unusually good during the past month, due in part to the brisk demand for dance records of all kinds. The new June records seem to be taking exceptionally well with the trade.

The annual summer resort trade has made its appearance considerably earlier this season, a result probably of the hot weather experienced since the latter part of May. Milwaukeeans will make their exodus to their summer homes from now on, the real rush beginning just as soon as the schools are out. Nearly everybody who owns a summer home owns a talking machine, and, in case the machine is a large one, the owner does not usually care to move it to the summer home, but prefers to buy a smaller machine. The sale of records to summer resorters has been remarkably good thus far, as no one wants to go to the lake without a liberal supply of the latest records.

Dealers and jobbers are confident that the coming fall trade will be satisfactory. One of the most hopeful signs is found in the first Wisconsin crop report of the present season, recently issued by James C. MacKenzie, secretary of the State Board of Agriculture. The condition of winter wheat is reported at 92.2 per cent, as compared with a year ago. The condition of practically all other crops shows satisfactory gains, while the general acreage is considerably larger. When crops in Wisconsin and surrounding States are good, it is an unerring sign that general business will be good. Retailers about the State seem to have confidence in the outlook, as most of them have been placing good orders for machines and records.

An event of more than usual interest in Milwaukee talking machine circles took place on June 1, when Miss Gertrude F. Gannon, until recently head of the Wisconsin Talking Machine Co., jobber for the Victor line in this State, was married to Edward J. Yockey, District Attorney of Milwaukee County. The ceremony was performed at St. Patrick's Roman Catholic Church in Dixon, Ill., the former home of the bride, by the Rev. Father Michael Foley. Among the wedding guests were Mrs. Yockey, mother of the bridegroom; his brother, Chauncey Yockey, exalted ruler of the Milwaukee Elks; Sheriff and Mrs. Lawrence McGreal, sister and brother-in-law of the bride; Assistant Superintendent of the Chicago, Milwaukee & St. Paul James Davoy and wife, of Milwaukee. Mr. and Mrs. Yockey are spending most of their honeymoon at Asbury Park, N. J., and on their return to Milwaukee will reside at 476 Bradford avenue.

Mrs. Yockey long had the distinction of being the only woman talking machine jobber in the United States, and there have been few young women in the talking machine business who have been as widely known as she. Mrs. Yockey also owned the McGreal retail Victor store at 312 Grand avenue, where she built up an extensive retail trade. The goom has acquired prominence in the office of district attorney as a prosecutor of unusual ability, and he is known as one of the youngest district attorneys in a city of this size in the country.

The Flanner-Hafsoos Piano House, 417 Broadway, recently opened its three new and handsome parlors, where the Edison line of machines is being featured to advantage. The parlors are separated by sound proof walls and are decorated in conformity with the other portions of the main floor of the piano establishment. The house has had the agency for the Edison line less than two months, but both Florian F. Flanner and Eric S. Hafsoos say that business has far exceeded their expectations.

Victor sales during the month of May at the Edmund Gram Piano House established a new high record, according to Paul A. Seeger, manager of the Victor department. Mr. Seeger and family recently returned from a business and pleasure trip to his former home at Milton Junction, Wis.

The Columbia line of machines, as well as A. G. Kunde, 615 Grand avenue, Columbia jobber and dealer, received some fine publicity during April and May, as the result of Mr. Kunde's action in disposing of five Columbia graphophones to the Milwaukee Free Press for distribution as prizes, in the big \$20,000 circulation contest, recently brought to a close by the Milwaukee daily. Pictures of the machines, together with Mr. Kunde's name, were published frequently by the Free Press during the contest, and the result was that Mr. Kunde has been meeting with a decided increase in business. Those who won Columbia machines in the contest included: August Motha, Theresa Schumann, F. A. Jewett, Delvigne Zeller and Floyd Bienfang, the latter a resident of Jefferson, Wis.

With their fight against extradition to Milwaukee pending before the United States Supreme Court, where it had been taken from the Court of Appeals of the District of Columbia, Franklin C. Goodale and his wife, Pearl, charged with obtaining money under false pretenses in selling stock in the Goodale Phonograph Co., of Washington, D. C., returned voluntarily to Milwaukee recently. They were accompanied by a Washington attorney, and they immediately began efforts to have the case brought against them by Miss Hattie Kluber dismissed. Goodale and his wife assured District Attorney Yockey that they were ready to refund \$250 to Miss Kluber, and that they would settle any other claims which might be brought against them in Milwaukee. On request of the district attorney, the case against the Goodales was dismissed. It had been alleged that Goodale and his wife had disposed of considerable stock in the Goodale Phonograph Co. to many working girls of Milwaukee, after having painted in rosy colors the great future of the concern and the big dividends which might be expected.

"These hard working girls will get their money back," said Assistant District Attorney Sloan, to the court, "and that is all we want. I had rather settle the case this way than to go to trial, for in that event the girls would get nothing."

According to the assistant district attorney, the Goodale Phonograph Co. is incorporated in Washington, D. C., and Goodale has an invention that is highly thought of by many.

The H. C. Block Co., 445 Milwaukee street, representative of the Columbia Dictaphone in Milwaukee, has been making sales to some of the largest business houses in Milwaukee. H. H. Block, secretary-treasurer of the company, says that business is double that of a year ago.

C. W. Abbott, manager of the Victor department at the Boston store, reports an exceptionally fine demand for machines and records from people who are preparing to leave for their summer homes. An unusually good business from this source is also being received by L. C. Parker, manager of the Victor department of Gimbel Bros. Mr. Parker says that trade during the month of May was considerably in excess of the corresponding month of 1913.

Since J. H. Becker, Jr., resumed the management of the talking machine department at the Hoeffler Manufacturing Co., 306 West Water street, he has been keeping the trade busy watching the attractive window displays which he has been arranging. Mr. Becker reports some fine Victrola sales during the past few weeks.

William A. Schmidt, general manager of The Phonograph Co., of Milwaukee, jobber in Wisconsin and Upper Michigan for the Edison line of machines, is in Northern Michigan, where he is establishing several new Edison disc dealers. The

Edison list of dealers in Wisconsin and Upper Michigan has been showing steady increase of late. A brisk retail trade in The Edison Shop, also under the supervision of The Phonograph Co., of Milwaukee, is reported by Miss Margaret Schumacher, office manager of the company.

L. F. Bidinger & Co., of Kenosha, Wis., have leased the Kent building at 458 Market street, that city, where they have been enabled to double their Victor quarters. The Kent building has been thoroughly remodeled for the Bidinger concern.

Joseph F. Gannon, brother of Mrs. E. J. Yockey, formerly Miss Gertrude F. Gannon, until recently head of the Wisconsin Talking Machine Co., was married on June 3 in Dixon, Ill., his native city, to Miss Gladys Roddenbau, a well known young woman of Milwaukee. Mr. Gannon, who is a deputy sheriff of Milwaukee county, was formerly assistant manager of the Wisconsin Talking Machine Co., jobber for the Victor line.

When you hear a fellow boasting that he has money to burn, don't be in any hurry to call out the fire department.

UNION No. 1

Patent No. 776-672, others pending.



PRICES:
Gold plated\$5.00
Nickel or oxidized .. 4.00

4 Easy Sellers—



UNION MODIFIER Pat. Pend.

PRICE.
Gold plated, nickel or oxidized....\$1.00

THE upper illustration shows UNION No. 1, for playing Columbia and Victor records on Edison Machines. UNION No. 1 contains the UNION Modifier feature. The second illustration shows the UNION Modifier, a quick-selling device, giving Edison, Victor and Columbia owners absolute control over the volume of sound.

UNION TALKING MACHINE SPECIALTIES

AT the right is the new UNION Sound Box, just out, taking Fibre or any make of needle. It is the latest improvement in sound reproduction, and fits all Disc Machines.

UNION SOUND BOX

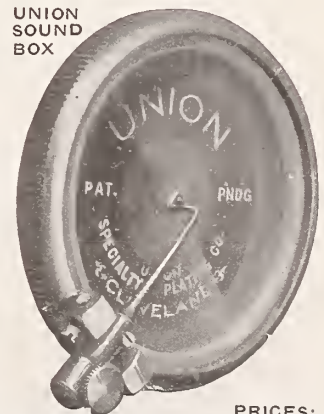

The UNION Needle Box shown below fills another long-felt want.

Write to-day for descriptive folders and prices on these four easy-selling specialties.

All persons selling goods infringing our patents are liable to suit for such infringement.

PRICES:
Gold plated, \$5.00.
Nickel, or oxidized, \$4.00.

The Union Specialty and Plating Co.

409 Prospect Ave., N. W. Cleveland, Ohio

LIST PRICES SHOWN HERE UNION NEEDLE BOX for Edison Machine. USUAL DISCOUNT TO DEALERS

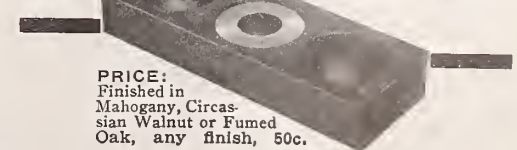

PRICE:
Finished in Mahogany, Circassian Walnut or Fumed Oak, any finish, 50c.

THE COST OF DOING BUSINESS

Should Be Understood by Merchants in Every Line in Order That They May Know Exactly Where They Are at and Develop Their Business Along Successful and Healthy Lines.

Ignorance regarding the actual cost of doing business is frequently the cause of many business failures. "During the next few years some of the tidiest profits in American industry will be saved out of operations. Heretofore, much of our profit has been made; but saving profit is a different thing altogether." That is the keynote of the remarkable interest in manufacturing and most of production systems which has appeared since 1905. A nation of born salesmen and advertisers, we have heretofore solved the problem of making more profits by getting more sales. Competition has now forced us to realize that an increase of advertising and selling expense will not continue to increase the business in direct proportion to the increase of expense. Such conditions must be met not only by advertising and good salesmanship, but we must go a step further. It means better systems of bookkeeping, closer inventories, more careful checking of every item of income and outgo, more accurate methods of knowing what each employe produces—in short, one must know what it really costs him to sell goods in order to make the right price. The same principle rules business in all lines. Cost, more than price, fixes profits. The public fixes the price it will pay. The dealer may keep it high, but the public fixes the limit, low or high, of what that price must be.

Many manufacturers depend on their balance sheets to determine cost, and their competitors to fix price. This is guesswork of the most treacherous and deceiving sort. Even the street faker selling collar buttons knows what his costs are, and in this respect knows more than some large enterprises, which really know surprisingly little about how much it costs to put their output down at the point of final delivery. Many a retailer doing a business of \$50,000 a year will tell you that "a cost system is only for manufacturers." It has been well said that the average business executive fails to get more than a small fraction of the vital facts and statistics that he should have to intelligently control the activities of a business. The desire to dodge the expense of the necessary system that will bring such vital statistics to the executive desk has made this condition. Contrary to the somewhat prevalent idea, however, there is no inherent complexity in system just because it is a system. It may, however, be suggested that the observance of any logical routine in the handling of business is so repugnant to the training and style of some business men that they take refuge in the absurdity that "all system is red tape," with the often painful result that they fail without knowing why, therefore being denied the important lesson their failure could have taught a man with a more analytical mind. That this attitude on the part of business men is too general and often fatal is generally conceded by those whose occupations, such as bankers, lawyers, judges, expert accountants, referees in bankruptcy, etc., bring them into close contact with business troubles or failures.

Every talking machine merchant should keep in close touch with his selling cost.

When you leave your customer before she gets her change and package, don't forget the package. Be on the alert to hand it to her as soon as ready.

AN ARTISTIC CUT-OUT WINDOW DISPLAY

Is That Which is Now Being Issued by the Columbia Graphophone Co. and Designed to Assist Dealers in Developing Their Dance Record Business—Where Properly Displayed It Has Won Universal Approval and Has Been a Big Factor in Increasing Business.

The Columbia Graphophone Co. has just issued an artistic cut-out window display that is attracting considerable attention wherever it is shown. Designed to assist the dealers in developing their dance record business, this window display certainly fulfills its mission well, as many dealers

panying illustration, is attractively conceived in every detail. The machine featured is the new "Mignonette," which is quite a favorite with Columbia dance enthusiasts. The human interest poses of the dancers adds to the appeal of this window display, and the harmonious blending of



have written letters of praise to the company's advertising department relative to the display's distinctive merits.

The new Columbia dance display stands over two feet in height, and, as will be seen by the accom-

panying illustration, serves to further emphasize its high-class finish.

As an aid to the talking machine dealer in increasing his dance business this sign possesses many novel and commendable features.

RETURNS FROM WESTERN TRIP.

George W. Lyle, general manager of the Columbia Graphophone Co., returned to his desk Tuesday after a short trip to several of the leading trade centers of the country, including St. Louis, Chicago, Indianapolis and Pittsburgh. Mr. Lyle was very optimistic in his reports of business conditions in these cities, stating that everyone he met was well pleased with the outlook, and predicted a prosperous fall trade. Mr. Lyle also advised the managers regarding a number of important deals while on his trip whereby the Columbia products will greatly enhance their prestige. These new deals will be announced in the near future.

Mr. Lyle was the recipient of congratulations from all the Columbia staff on the occasion of the celebration of his twenty-fourth wedding anniversary, which took place on Wednesday. There are rumors of some large happenings among the Columbia employes on the same date next year.

A certain eminent lawyer has said, in reference to the Sherman act: Strictly speaking, it would be a violation if you and I were to agree to live until the year 1920, for this would constitute a combination in restraint of the undertaker's trade.

There is just as much difference between fact and fiction as there is between a woman and her photograph.



The Columbia automatic stop. The most accurate automatic stop made and the easiest to operate.

Gun Metal, \$2.00 list. Nickel Plated, \$2.50 list. Gold Plated, \$3.00 list.

May be adjusted to both Columbia and Victor disc machines. Order from any Columbia Distributor.

COLUMBIA GRAFONOLA PARLOR

In Atlantic City, N. J., Is Meeting with Great Success—Is Operated by Joseph Piacentini, Who Is a Former Member of the Well-Known Vessella's Band—Building Up Good Trade.

One of the many live-wire Columbia dealers near New York is the Columbia Grafonola Parlor, Atlantic City, N. J., operated by Jos. Piacentini, and

products through his ability to discourse informatively on this subject.

Aside from his musical ability, Mr. Piacentini is a most aggressive merchant and takes advantage of every opportunity to profit by Columbia publicity, co-operation or service. On the occasions of the visits of Columbia artists to Atlantic City, which are frequent occurrences, Mr. Piacentini uses excellent copy in the daily newspapers calling attention to the appearance of the various artists and

rheum, or pink eye. Every man we come to has a grouch, complains of dull times, and doesn't believe in advertising any way. If we are out early, we are too early, and if we come later, we are too late.

If they have good times, the buyers tell us they do not need to advertise because they are getting more business than they can take care of. If somebody tells them times are dull, they pull a long face that would make an undertaker green with envy, every time they see a salesman.

By the way, we have our old friend Dull Times with us always. There is always some locality somewhere in the United States any month in the year where the calamity howlers rule things with a high hand, and pessimism is like a pestilence.

PATHÉ FRERES PHONOGRAPH CO.

Now Established in New Home at 29 West Thirty-eighth Street, New York—Occupying Entire Second Floor of Spacious Building—Expects to Be Ready for the American Market Early in August.

The Pathé Freres Phonograph Co. is now established in its new home at 29 West Thirty-eighth street, New York, where it occupies the entire second floor of a new building with a floor space of 5,500 square feet. The officials of the company state that they will be ready for the American market about the first of August, and, in the meantime, they are conducting a recording laboratory at this address, in addition to maintaining showrooms.

T. Labrely, chief engineer of all the Pathé industries in Paris, France, is at present in New York, supervising the equipment of a pressing plant, which will probably be located in Brooklyn, N. Y. Russell Hunting, well known in the talking machine industry, has been appointed chief director of recording.

There are now on display at the showrooms a complete line of the machines which the company expects to market this summer, including the Pathephone, Pathegraph and Pathedisks.

MANAGING TOWER'S DEPARTMENT.

A. N. Struck, formerly connected with the Edison disc department of Krakauer Bros.' warehouses, 17 East Fourteenth street, New York, was recently appointed manager of the Edison department of the Tower Manufacturing & Novelty Co., 326 Broadway, New York. Mr. Struck succeeds Dana F. Parkhurst, who returned to his home in Topeka, Kan., prior to starting on an extended concert tour of the country. Mr. Parkhurst is a baritone of considerable prominence.



Columbia Grafonola Parlor at Atlantic City, N. J.

the interior of which is shown in the accompanying illustration. A former member of the popular Vessella's Band, Mr. Piacentini has succeeded in securing an extensive list of patrons in his territory who are frequent visitors at his establishment. Mr. Piacentini finds his comprehensive musical knowledge invaluable to him in his present business, and has won many friends for Columbia

emphasizing the fact that they have recorded for the Columbia library.

The up-to-date appearance of the Columbia Grafonola Parlor is in keeping with its owner's progressiveness and up-to-date methods, and by the use of ear cards, theater program advertising and high-grade publicity of every description Mr. Piacentini keeps the booths in the store well filled.

Either the weather man spills something disagreeable, or the thermometer is trying to break the record, or there has been seventeen salesmen ahead of us (maybe eighteen), everybody says he has bought, or that we are robbers, or that our goods are not up to snuff, or there is a local agent that is trying to monopolize everything, or we are troubled with a cold in the head, rheumatism, salt

DEMAND FOR RECORD ALBUMS.

The National Sales Are Steadily Growing with Live Talking Machine Men.

The demand for the disc record albums manufactured by the National Publishing Co., 235 South American street, Philadelphia, is growing steadily in popular favor. They are made in the most substantial manner by skilled workmen and are very substantially built, so that hard handling does not wear them out. They will fit in any library cabinet or bookcase, or they will lie flat on one and other.

There are seventeen pockets for records, which are made of extra strong manila paper and firmly secured to heavy guards in the back of the album. They are bound in a fine quality of brown silk finish cloth, the cover being stamped Record Album on the front. An embossed border line enhances the beauty of both front and back cover. For the convenience of customers who at any time desire to rearrange their discs, there are six pages for indexing, three in front and three in the back. Each page of the index contains seventeen consecutive numbers, each number having two lines, thus making a title page to register records as placed in the pockets, the pockets being numbered one to seventeen in regular order.

Talking machine men have had very satisfactory results from the sale of National albums, and the demand for them is greater than ever before, showing that where they have been properly displayed there has been a steady demand for same.

GETTING RID OF THE GROUCH.

Did you ever notice how many ideal days there are, and how many there are of the other kind? By an ideal day we mean one in which it is neither too hot nor too cold, it does not rain or snow, every man we come to is ready to talk business, nobody has ever tried to sell him any goods, nobody says our price is too high, nobody kicks about anything, and every man gives us an order.

Some houses do more business

than others, and the only explanation of this feature, when the products are the same, is the quality of the service rendered by the jobber to the dealer. This explains the rapid development and large growth of

Louis Buehn
Philadelphia

for in catering to your wants and aiding you to close sales by giving quick deliveries, you know and appreciate the value of our work.

Edison Cylinder and Victor Products

We told you so!

Told you what?

That 1914 would be *the* Columbia year in the talking machine trade. The middle of 1914 is here—and we're right here with it, where we said we would be.



(Write for "Music Money," a book "full of meat" for those dealers interested in quick and frequent turnover of capital.)

Columbia Graphophone Company
Woolworth Building, New York

THE QUAKER CITY TRADE AHEAD OF A YEAR AGO.

This Satisfactory Condition Exists in Very Few Lines, but the Talking Machine Is an Exception—Dealers Handling all Makes of Talking Machines Active in Developing Their Business and Making Their Stores More Attractive—News Budget of Month.

(Special to The Talking Machine World.)

PHILADELPHIA, PA., June 8.—The talking machine business in Philadelphia during May progressed in a most satisfactory way, and while there has been some falling off in comparison with the business done during the previous four months of the year, yet this was naturally to be expected, and generally May was better than the May of 1913. There is very little complaint among the dealers at present, for the factories are keeping them pretty well supplied.

During the month of May there have been no changes in Philadelphia in the way of new dealers, and there are not likely to be any during the summer. There is a lull in the booming of the little talkers for the reason that the dealers recognize that business is bad and we are getting into the mid-summer season, and that money would be wasted by an aggressive campaign.

The Victor Co. has again sent out an appeal for the support of the Stevens Price Standardization bill, known as H. R. 13305. The intention of this bill is to establish the one-price-to-all principle on branded merchandise, and to militate against price-cutting, dishonest advertising and other unfair practices of great trading monopolies.

Gimbel Bros. still have a great many Keen-ophones on hand which they were able to dispose of at their recent sale, and they are running a bargain sale on these instruments this week.

Louis Buehn reports that his business in May was most satisfactory, although showing a slight falling off in comparison with the previous months of the season, but an advance over May of last year. He has at present the biggest stock on hand that he has ever had in the history of his business. His Edison dictating machine business has shown an increase during May. He completed the installation of these machines with the Atlas Powder Co., of Wilmington; placed additional machines with R. G. Dun & Co., and placed a number of machines with the Frank H. Stewart Electric Co. and with other firms.

Lit Bros., whose talking machine department is in charge of A. L. Münchweiler, have been making a feature of dance records and have been advertising them heavily. Their sales on these records have been large.

The business at Gimbel Bros., during the month of May, was at least double that of last year, owing, no doubt, to the great publicity brought to their department by their advertising schemes. Manager H. H. Stewart, who is in charge of the department, and who has been ill for some weeks, has so far recovered that he is able to be removed to Atlantic City to recuperate. He has gone there with his family for an indefinite period. David Davidson, who was connected with the talking machine department as salesman, has resigned.

Manager Elwell, of the Heppe wholesale depart-

ment, notes that business in May was very satisfactory, "when you consider that it was May." "We more than held our own," he says, "and we look for a good summer business, and will be able to take good care of it now that machines and records are coming through so promptly."

The Pennsylvania Talking Machine Co. reports that it has been having a remarkably good retail business in May—very much better than last year, and Manager Eckhart says: "We feel, considering what others say, that we have been very fortunate." The firm has placed no new agencies during the month, but it has some good prospects pending. Mr. Eckhart will go to Atlantic City at the end of this week to rent a cottage where he will take his family during the summer.

After about two months of renovation the Wanamaker talking machine department has finally been completed, and, in its present improved condition, not only presents a much better appearance, but it greatly facilitates the department in handling customers. The hearing rooms have been more than doubled, and the large concert hall will be an appreciated attraction when the fall activity sets in.

A CHANGE IN MILWAUKEE.

Miss Gertrude F. Gannon, Who Recently Married, Disposes of Her Interest in Wisconsin Talking Machine Co. to C. M. Backus.

(Special to The Talking Machine World.)

MILWAUKEE, Wis., June 11.—Following the announcement of the marriage on June 1 of Miss Gertrude F. Gannon to Edward J. Yockey, district attorney of Milwaukee county, comes the news that Mrs. Yockey has disposed of her interests in the Wisconsin Talking Machine Co., jobber for the Victor goods, and has sold her retail store at 312 Grand avenue.

C. M. Backus, of Chicago, who was formerly a stockholder in the Wisconsin Talking Machine Co., purchased most of Mrs. Yockey's holdings, although there are other stockholders in Chicago and Milwaukee. The Victor jobbing business will be conducted under the same name, the Wisconsin Talking Machine Co., but the retail store, conducted for many years under the McGreal name, will be designated under a new name, not yet selected. Officers of the Wisconsin Talking Machine Co. have not been definitely selected at this writing.

Harry R. Fitzpatrick, who so efficiently served as general manager of the Wisconsin Talking Machine Co., during the time that Miss Gannon was president of the company, remains in charge and has plans under way for pushing the business with even greater vigor than in the past. L. E. Dresel, formerly of Chicago, will be in Milwaukee as representative of the main stockholder, C. M. Backus, and will act as treasurer of the company.

Blake & Burkart, the Edison dealers, with parlors at Walnut and Eleventh streets, have still further improved their handsome rooms, and although they have been in the talking machine business only about two months, they have established an excellent trade and their business has been very good. It dropped off a little bit the end of May, but thus far in June it has been elegant. They were favored this week with a visit from Greger Skolnik, the eminent violinist, who makes records for the Edison. His "Andalusia Romanza" is one of their most popular instrumental sellers. They have closed their weekly concerts, which have been very well attended, and will not resume them until the cool fall weather. They have taken on a new salesman named Harry Wilson, who has been doing very well. On the back of the Edison machine, as well as their record catalogs, they are using an excellent picture of the interior of their warerooms, which are the finest talking machine rooms in this city in elaborateness and taste in furnishing.

H. A. Weymann & Sons have never had as many orders booked ahead for their fall business on the Victor as at present. Not so long ago they sent each customer a letter calling attention to the desirability of ordering early, and that they had gotten an unusually big supply of both machines and records on hand, and in consequence their dealers are placing their orders with the view evidently that business was going to be excellent this fall.

SOME NOTABLE ARTISTS.

The July list of Victor records will present the first records made by four new Victor artists, Margaret Ober, Paul Althouse, Margaret Romaine and George MacFarlane. All of these artists are well known in either the concert or operatic world.

PHONOGRAPHISCHE ZEITSCHRIFT

BERLIN C. 19, GERMANY

The oldest and most up-to-date trade paper covering the talking machine line published in the German Language.

PUBLISHED WEEKLY. FOUNDED 1900

Circulates all over the world.

SPECIAL EXPORT NUMBERS
appear in four different languages at regular intervals.

Subscriptions for this talking machine publication 10 Marks yearly.
Sample copies sent free.

FROM OUR EUROPEAN HEADQUARTERS

2 GRESHAM BUILDING, BASINGHALL STREET E. C., LONDON, W. LIONEL STURDY, MANAGER.

General Review of Trade Conditions Shows Pessimism Having a Firm Hold in Industry—Nevertheless Profit Figures for the Year Will Compare Favorably with Those for the Same Period of a Year Ago—The Cheap Record Policy Comes in for Severe Criticism—Room for Uniform Remedial Action—Lack of Co-operation Among Manufacturers a Subject of Regret—Important Musical Copyright Case Comes Up Again for Consideration—Papers Read at Music Trade Convention—News of the Month Worth Recording.

(Special to The Talking Machine World.)

LONDON, E. C., June 6.—Talking machine trade in this country would seem to be in a somewhat parlous state if one's opinion be guided or influenced by the pessimistic section, whose mission in life is to decry any and everything. Not for one moment do I suggest that trade conditions are anywhere near as healthy as we should like, nor can it be said that sales are altogether satisfactory. Business is certainly quiet, but, circumstances and time of year considered, I do not believe that, comparatively, we are much behind the profit figures of even time last year. Present-day figures may in bulk show even an increase; it costs considerably more, however, to secure a given turnover, and thus on the profit side a slight setback may obtain. This, of course, is one effect of the cheap-record policy introduced at the commencement of this last season and vigorously maintained ever since. Special inquiries made around the trade elicit information which tends to confirm the belief that manufacturers will not withdraw the shilling proposition except under general agreement. The British Zonophone Co. has intimated to me that it does not propose to vary its policy in respect of the half-crown Zono records, or the thirtepenney "Cinch" record, but all other manufacturers, I believe, would be quite willing to eliminate this unprofitable business. Briefly, the lack of co-operation among manufacturers has resulted in the gradual introduction of cheap records until to-day the market is flooded with passably good discs at one shilling retail. These may be sold at anything from 4s. 6d. per dozen upwards to 8s. 6d. wholesale. The former price is absolutely below first cost, and whatever reason determined such trade, the result, with which I am mainly concerned at the moment, is obviously appalling in its effect. Its pernicious influence is felt right along the line to all sections of the trade and we find all classes of dealers descend to price cutting, if the term can be applied to records, of which many do not even carry a semblance of fixed selling price. Now arrives a talk of agreement among manufacturers to abolish records below eightpence in price, establish a definite policy of trading, rigidly enforce price maintenance, fix wholesale and retail prices and generally control the distribution of goods even to the extent of refusing supplies to those dealers who do not exclusively handle the products of the associated houses. There would be no attempt to exploit the retailers, the plan in all its phases being devised for their protection. Both the manufacturing and wholesale sections should bind themselves under monetary penalty against a breach of any "understanding" come to, and it is further planned to exclude any free and open competition.

Musical Copyright Again Up.

Notwithstanding the general assumption of the sheet-music publishers that the Copyright Act of 1911 was framed along lines more favorable to gramophone record manufacturers than themselves, a totally different complexion is given the case by the judicial bench in its searching examination of the many obscurely worded clauses and provisions of this contentious act.

Several important actions have been tried out, with results mainly adverse to the gramophone

record industry. These actions have from time to time been fully reported in our columns, and those who have followed with care the growing favorable position of the publishers as disclosed by the judicial findings in question realize that at least the latter's complaints have little foundation in fact under the copyright laws, whose gradual elucidation is not so palatable as the gramophone trade would wish.

An assignee's right in musical copyright formed the subject of a recent case for judicial opinion, in the result of which, of course, general trade interest was keenly manifest. Messrs, Chappell & Co., Ltd., the great music publishers, claimed the right to restrict record manufacturers from copying the music of songs of which the copyright was vested in them under an assignment. It was purely a test action and the Columbia Graphophone Co. was cited as the defendant. Infringement was alleged in regard to a song called "Where My Caravan Has Rested."

Judgment.

Justice Neville: The defendants in this case copied the music of the song the copyright in which was vested in the plaintiffs under an assignment. The assignment was made prior to the Copyright Act of 1911. The music was copied in this way. It was published with a pianoforte accompaniment and the defendants adapted it for an orchestra in a written score. I think if this were all it would amount to an infringement to the plaintiffs' copyright. It is a copy of the musical work and it is not within the exceptions enumerated in Section 2 and the act. The orchestration was, however, for the purpose of obtaining a gramophone record of the song with orchestral accompaniment. Does the purpose for which the copy was made exonerate the defendants from the charge of infringement? Prior to the act of 1911 it had been held that rolls constructed for the purpose of mechanically reproducing the music were not copies and no infringement. See *Boosey vs. Wright*, 1900, 1 Chancery 122. Nor would I think, having regard to that decision, the creation of a gramophone record to be a copy or an infringement. The act of 1911 gives a limited right to the author or owner of a musical work in respect of records created for the purpose of mechanically reproducing the music. In the case of an assignment prior to the act this right is given to the author and not to the assignee. Assuming what the defendants have done to have been no infringement of the author's right in respect to the record, can that alter or limit the right of the assignee to the protection for the musical work which vested in him at the date of the assignment? I do not think it can. The act of 1911 does not purport to affect or diminish the copyright of the assignee and I think that such right is not altered. I have already said that what the defendants have done would in itself, and taken by itself, be an infringement, and I think it remains so notwithstanding the right to protection given to the author in respect of mechanical records.

I think, therefore, the plaintiffs' action should succeed and that they are entitled to the relief asked under claims 1, 2 and 3 and to the costs of the action.

Mr. Gore-Brown: I do not know whether my learned friend would be content with a declaration in this case. Of course it has been treated quite fairly as a test case by those concerned.

Mr. Jenkins: My instructions are to ask for an injunction and I think in the absence of instructions your clients must communicate with mine, and I must take your Lordship's order for the present.

Justice Neville: If you are both agreed you can draw it up in the form of a declaration;

otherwise I think I am bound to grant the injunction asked for.

Mr. Gore-Brown: In paragraph 2 of the statement of claim they ask for "an injunction to restrain the defendants, their servants and agents from using any copies of the music of the said song without the plaintiffs' consent." I want the word "made" in before the word "without."

Justice Neville: Very well.

Mr. Gore-Brown: We have only one copy and we will deliver that up.

Mr. Jenkins: Yes.

The Music Trades' Convention.

The papers read and subjects discussed at the fourth music trades' convention, held at beautiful Bournemouth, May 7 to 12, inclusive, were for the most part of a highly practical nature and well calculated to exert a powerful influence in the campaign against the several commercial troubles peculiar to the music industry. A conspicuous feature of this convention was the total absence of anything bearing upon the talking machine trade beyond the importance of the musical arrangements of the "His Master's Voice" Co. The chairman of the convention paid a well-merited tribute of thanks to the company for the talented artists who, at its instigation, had so immensely added to members' enjoyment by the excellence of their concerts. The whole musical program was organized by S. W. Dixon, a director of the Gramophone Co., Ltd., assisted by Messrs. Ricketts, Colledge and Langley. Aside from the high importance of this representation, it is a matter for very great regret that the gramophone industry was not otherwise in evidence on the business side of the convention. H. J. Cullum filled the gap last year and it must be heartily desired that we shall not again lose so fine an opportunity of associating this trade with other branches of the musical industry.

The Death of Barry Owen.

The recent death of Barry Owen calls to mind that he was mainly instrumental in founding the Gramophone Co., Ltd., then styled the Gramophone & Typewriter, Ltd. In 1898, I believe, Mr. Owen came to this country from America with the object of introducing what was then regarded as a wonderful toy. He it was who brought over the first gramophone that operated by hand. In those days such a thing as mechanical drive for rotating the turntable had scarcely been thought of. Anyway, this talking instrument created enormous interest. For the exploitation of this novel invention of Berliner's, Barry Owen endeavored to float a big company, Trevor Williams, the present chairman of the company, quick to perceive its commercial possibilities, went right in and soon incorporated a large company. It proved phenomenally successful, so much so that when the sanguine Barry Owen found the public willing to subscribe, as they did, by the way, enormous sums of money, it is said, he had misgivings as to the ability of the concern to pay any dividend on such a large capital. Not to rely, therefore, upon the gramophone alone, he persuaded the directors to take up the sale of a new typewriter—the Lambert, I think it was called—and so was born the name Gramophone and Typewriter, Ltd. Although the company has long since dropped the word typewriter, even to-day it is occasionally used by correspondents and visitors. But that by the way. Barry Owen never quite recovered his confidence in the business and he eventually sold out his shares, I am informed, at twelve shillings each. Since then those same shares have reached over £4 in value and to-day stand at 28s. 6d.!

Trade with China.

The need of a thorough investigation into the conditions and prospects of British trade in China
(Continued on page 48.)

FROM OUR LONDON HEADQUARTERS—(Continued from page 47).

has been urged by manufacturing circles and on the recommendation of the advisory committee on commercial intelligence the president of the Board of Trade has appointed T. M. Ainscough as a special commissioner to proceed to China for the purpose named.

New Companies Incorporated.

Ajax Record Manufacturing Co., Ltd. Capital, £1,000. Office, 54 Redcross street, London, E. C. Newtillities Syndicate, Ltd., gramophone manufacturers. Capital, £500. Office, 35 Glasshouse street, London, W.

Louis Sterling Returns.

Underlying the world-wide ramifications of the Columbia Graphophone Co. is a commercial organization second to none in efficiency and foresight. It has reached that pitch of perfection which should count in round figures as an asset in their balance sheet. Preparations for the season's campaign have to be made months ahead. That is where organization tells. Special attention is given to the individual requirements of each market and no stone is left unturned to insure perfection in every detail. In accordance, therefore, with this policy we find the executive of the Columbia company in conclave at the American quarters with prominent officials from the London branch. Louis Sterling has just returned and your correspondent seized an early opportunity of indulging in a short chat with him on trade matters in general. "It would be somewhat premature at the moment to review our arrangements for the season," said he, "but in conformity with our policy of developing trade, particularly in the high-grade Columbia lines of records and machines, we have made certain arrangements for still further improvement and intend to push this end of the business vigorously during the coming season."

Notwithstanding increased competitive conditions here, the Columbia trade progress is comparatively unaffected; indeed as against any previous year the company's sales figures are substantially up.

"The position of this company," continued Mr. Sterling, "was never stronger than it is to-day; our policy is a settled one and the trade confidence we enjoy in consequence is good enough encouragement for us to continue and even strengthen a service which is obviously productive of such mutual satisfaction."

While in the States Mr. Sterling naturally spent much time with his people, whom he found fit and well. He met several old friends there, notably Paul H. Cromelin, whose thoughtful message of remembrance to friends this side has been received with evident pleasure. I am desirous on their behalf to proffer per this medium hearty reciprocations.

Already in Harness.

Although but a few weeks old, the Performing Rights Co. has already got to work in a very practical manner. One of its objects is the collection of royalty fees from bands, orchestras and other public performers of copyright songs and musical selections. Places affected include hotels, restaurants, theaters, cinemas, kiosks, seaside pavilions and similar institutions. The company has acceded to the society's demand, although the hotel's manager expresses himself as dissatisfied. "We think ourselves not too well treated, as our musical performances are not for actual gain," he said, "but there is a legal point involved which it would be long and costly to fight, and so we respond to the demand for payment on the basis of a yearly contract." The figure involved is said to reach three figures. P. Sarpy, secretary of Performing Rights, Ltd., states: "We are only getting for British musicians and publishers what foreign musicians have had for years past. England has been the only country where music-makers were not organized for the purpose. Not all composers have joined us yet, but it is, I think, only a matter of time; already Messrs. Paul Rubens, Lionel Monckton, Hermann Lohr, Howard Talbot, Hermann Finck and Archibald Joyce are members. I don't think there is any likelihood of the work of these popular composers being

dropped because a fee is chargeable on performances.

"The fees will be strictly graduated in proportion to the size and importance of the establishment. We are exercising a legal right which has been in abeyance."

Excellent Selection of Records.

A prominent feature of "His Master's Voice" list of records for June is the excellence and number of the dance selections issued on double-sided records. As will be seen, the orchestras chosen for this work represent the very cream of the world's musicians, and the sparkling morceaux they contribute range from the one-step to the very latest vogue, that of the "hesitation." Other "jems" may be noted from a perusal of the full list, as follows:

Twelve-inch, double-sided: "Madame Butterfly," selection (Puccini), and "Dream Pictures" (Lumbly), Pryor's Band; "Queen of the Movies," two-step ("Kino Konigin") (Jean Gilbert), and "Somebody's Coming to My House," medley, Metropolitan Band; "La Boheme," selection I and II (Puccini), Mayfair Orchestra; "You're My Baby" (Nat. D. Ayer), and "Je Lais que vous etes polie" (Christiné), Jacobs and his Trocadero Orchestra.

Ten-inch, double-sided: "On Jhelum River"—Will the Red Sun Never Set, and "Oh Jhelum River"—The Song of the Bride (A. Woodforde-Finden, arr. by P. E. Fletcher), Band of H. M. Coldstream Guards; "Admiration," Waltz Hesitation (Carza), and "Toreador One-Step or Turkey Trot" (Gascon), Metropolitan Band; "If I Only Knew," waltz; "Schwindelmeier & Co." (R. Nelson) and "Valse Boston" (R. Drigo), Palais de Danse Orchestra.

Twelve-inch, single-sided: "Sylvia Ballet," intermezzo and valse lente (Delibes), New Symphony Orchestra; "Sylvia Ballet," cortege de Bacchus (Delibes), Ney Symphony Orchestra; "A Furtive Tear," "Elixir of Love" (Donizetti), Charles W. Harrison; "Comfort" (C. Novello

(Continued on page 50.)



To T.M. the King and Queen of Spain



To H.M. the King of Sweden



To H.H. the Khedive of Egypt



To H.M. the King of Italy



To H.M. the Shah of Persia



By Appointment To H.M. Queen Alexandra

"His Master's Voice"

—the trade-mark that is recognised throughout the world as the

Hall-mark of Quality

AUSTRIA: Oesterr. Gramophon-Gesellschaft, m. b. H., 8, Krugstrasse, Vienna.
 BELGIUM: Cie. Francaise du Gramophone, 51, Avenue de la Porte de Hal, Brussels.
 DENMARK: Skandinavisk Gramophon-Aktieselskab, Frihavnens, Copenhagen.
 FRANCE: Cie. Francaise du Gramophone, 115 Boulevard Richard Lenoir, Place de la République, Paris.
 GERMANY: Deutsche Gramophon-Aktiengesellschaft, 35, Ritterstrasse, Berlin, S42.
 HOLLAND: American Import Co., 22a, Amsterd, Veerkade, The Hague.
 HUNGARY: The Gramophone Co., Ltd., IV, Kossuth Lajos-Utca 8, Budapest.
 SPAIN: Cia. Francaesa del Gramophone, 56, Balma, Barcelona.
 SWEDEN: Skandinaviska Gramophon-Aktiebolaget, 52, Appelbergsgatan, Stockholm.

RUSSIA: The Gramophone Co., Ltd., 45, Nevsky Prospect, St. Petersburg; 9, Golovinsky Prospect, Tiflis; 30, Nowia Svit, Warsaw.
 EGYPT: The Gramophone Co., Ltd., 13, Rue Stamboul, Alexandria; Rue Mousky, Cairo.
 EAST AFRICA: Bayley & Co., 8 Beira, Lourenço Marques.
 SOUTH AFRICA: Darter & Sons, Adderley St., Cape Town; Mackay Bros., Rissik Street, Johannesburg; Mackay Bros. & McMahon, 443, West Street, Durban.
 INDIA: The Gramophone Co., Ltd., 139, Balliaghatta Road, Calcutta; 7, Bell Lane, Fort Bombay.
 AUSTRALIA: The Gramophone Co., Ltd., Hoffnungs Chambers, Pitt Street, Sydney.
 GREAT BRITAIN: The Gramophone Co., Ltd., 21, City Road, London, E.C.

Great Britain:

The Gramophone Company Ltd
 21 City Road London EC



ARRIVED AT LAST

"The World's Musical Instrument"

Gives *all* records the same chance!

SOON ON THE MARKET.

✿
Sounds
that are
truly
MUSICAL!



✿
Voices
that are
truly
HUMAN!

PLAYS TO PERFECTION,

without change of sound-boxes, EVERY disc record ever made and in such a realistic manner as never heard from any "Talking Machine," "Gramophone" or "Disc Phonograph" before.

(Read the views of the able Representative of this paper in London, about this new Instrument, on page 45 of March 15th, 1914.)

J. HOFFAY

67 Egerton Gardens, South Kensington, London, England.

FROM OUR LONDON HEADQUARTERS—(Continued from page 48).

Davies), Miss Alice Lakin (contralto); "What's It Got to Do With You" (Tennent), Miss Margaret Cooper; "An Old World's Garden" (Crampton, Ernest Crampton and Marjorie Vernon); "The Raven," Part I and II (on two records) (Edgar Allen Poe), Percy Hemus (dramatic reciter); "Beautiful, Beautiful Bed" (Murphy and Tipton), Alfred Lester.

Ten-inch, Single-sided: "Have You Seen But a Whyte Lillie Grow," Miss Alma Gluck (soprano); "The Carnival" (J. L. Malloy) Stewart Gardner (baritone); "Sweethearts Three" (Robert Coverley), Harry Dearth (bass); "Bye and Bye You Will Miss Me" (Stamper), Ethel Levey.

Real Bird Records.

A few years ago the Gramophone Co. issued a record upon which was engraved the sweet notes of a captive nightingale (this record, by the way, is still one of my treasured possessions), and now comes the welcome news that after very considerable patience a further series of real bird trills have been secured. These include two records by a captive sparrow, two more of a nightingale and one each of a blackbird and thrush. The records are most successful. Herr Carl Reich, of Bremen, who owns the birds, explains in an interesting manner some of the difficulties of securing these records. He says in part:

"Four years passed before we attained success. Only when I was alone with the bird would it sing; as soon as the recording machine was put into operation the bird would stop abruptly. Even if we do get the bird to sing with all his might he will cease singing the moment the machine is set in motion. He simply flies off to another spot. Where we have trained a bird to sing just in front of the horn he invariably slips to one side the moment he hears the noise of the machine working—and, of course, half the sound is lost, and often he will stop singing altogether.

"These difficulties seemed to point to the impossibility of success. I persevered, however, until at length I overcame this timidity of the birds. First of all I allowed the birds to fly about in the room. They were taught to return to the proper cage always. Their favorite food was placed in the mouth of the horn, behind which was erected a dummy recording machine. Whenever they went into the horn to fetch their pet food the clockwork was set in motion. To give more confidence to the birds I often got them to eat food out of my own hand. Inborn love of the birds, together with endless patience, enabled me after many years to get the birds accustomed to losing all their shyness and fear. In this way the machine and the horn became familiar to them. It was, so to speak, part of their life, like the beautiful park and woods they could see from their windows."

New Kind of Trumpet.

A new kind of trumpet is announced by the National Gramophone Co., Ltd. It is named "Resopan" and is made of a skin so cleverly treated as to represent a perfect imitation of wood, mahogany, chestnut, maple, etc. Without detriment to shape, it gives slightly under pressure, but cannot crack or break. Compared with a

wood horn, the "Resopan" gives forth a bright and solid tone and is in some respects much superior. The retail price of the new product is one guinea.

Must File a Balance Sheet.

Replying to a query in the House of Commons, the president of the Board of Trade said: "By Section 274 of the Companies (consolidation) Act, 1908, every company incorporated outside the United Kingdom which establishes a place of business within the United Kingdom is under the same obligation to file a balance sheet as a company registered under the Companies Act.

To Open in Manchester.

The Coliseum Record Co. informs me of its intention to open up a central depot in Manchester. This move is necessitated by its rapidly expanding trade up north. In addition to full stocks of records, the depot will carry full equipments of every known accessory and part connected with talking machines.

The Great Tenors in Duets.

The standing of Morgan Kingston as an English tenor of whom we have every reason to be proud, has been considerably enhanced by the news of his glowing success in grand opera in New York. This success, too, invests with particular interest the twelve-inch record bearing Mr. Kingston's name in the Columbia-Rena list for June, for on it that fine artist is to be heard in duets with Louis Kreidler, the leading baritone of the Grand Opera Company, in which Mr. Kingston has been singing. We thus have an additional attraction in the record, the two great voices giving us the duet, "Mimi's So Fickle-Hearted," from "La Boheme," and that favorite ballad, "The Moon Has Raised Her Lamp Above."

Plantor Home Recorder.

An interesting apparatus just introduced is the Plantor Home Recorder for disc machines. Its chief advantages as a commercial proposition are vested in extreme simplicity of construction, rendering it adaptable for use on any make of instrument, sensitiveness to even a whisper, and cheap recording-blank equipment. This latter represents a cardboard disc with wax surface, which is easily made, and can be sold very cheaply. Of ten-inch diameter, its capacity is an average of 1,000 words, although a rapid speaker could dictate to the tune of double this number on one disc. Your correspondent recently inspected this appliance, and found it in every way of practical value. As a commercial dictating machine, or as a home entertainer, this invention should fill adequately the proverbial long-felt want; for, in the latter connection especially, if there is anything lacking to complete the triumph of the gramophone, it is the means to record and reproduce one's own vocal efforts, without great expense. In this regard, therefore, a hearty welcome should await the Plantor Home

ATTRACTS WORLD-WIDE ATTENTION

Nearly Five Hundred Inquiries Received by J. Hobbay from United States and Canadian Dealers as a Result of Two Advertisements in the Talking Machine World.

(Special to The Talking Machine World.)

LONDON, ENGLAND, June 3.—Information has reached us from J. Hoffay, of 67 Edgerton Gardens, South Kensington, London, who is bringing out a new gramophone which some have called "the world's musical instrument," that widespread interest is created in this new product. Mr. Hoffay is expected to announce in The World within the near future the trade name under which the instrument is to be sold. He says he has found it more difficult to get hold of the right name than to complete his invention. He speaks very highly of the interest aroused among the dealers in the United States and Canada, and says that he has received over 400 letters, for which he gives credit to the advertising power of The Talking Machine World.

Mr. Hoffay is sure that his instrument will satisfy the expectations of the trade in every particular and will constitute an important asset to the dealer for the sale of records.

Definite information as to its selling policy, terms, etc., will soon be ready. He expects certain developments in his patent at an early date which will enable him to send out particulars, together with catalog.

Recorder, for which B. Frankel, of the British Plantor Co., 63 Theobald road, London, W. C., holds the exclusive agency covering Great Britain and its colonies.

Recordings of London String Quartet.

The famous London String Quartet is represented by exclusive recordings on a 12-inch Columbia-Rena record this month. The selections they play include Tschaiakowsky's beautiful "Andante Cantabile" (a record which has been much in demand of late), and Haydn's Hymn to the Emperor, also known as the Kaiser Quartet, but perhaps best known for its melody as the Austrian Hymn. It is doubtful whether two better titles could have been chosen to display the artistry and consummate mastery of the quartet, and our congratulations are due alike to Columbia and the record world on the issue of so notable a record in a standard catalog.

New Records by Mme. Fremstad.

A new record by the great Wagnerian soprano, Mme. Olive Fremstad, is always an event of moment, but the issue on the Columbia Celebrity series this month is rendered doubly so by the fact that it shows her in excerpts from two of her greatest Wagnerian roles. As heard in Brunnhilde's battle cry, we have the wonderful voice in superb control, while in "Du bist der lenz," the lyrical passage from the same work ("Die Walkure"), we have a number of immense beauty, both revealing the famous soprano in flawless voice.

One of the most interesting announcements of the month is that of a new Columbia record by Madame Cavalieri. She sings "O Solo Mio," while Tosti's popular "Nattinata" is given on the reverse of the 10-inch disc.

TRIUMPHON CO., Ltd.

ESTABLISHED 1884

Berlin, S. W., 47/5
MANUFACTURERS

OF ALL ACCESSORIES SUCH AS

MOTORS

10 different models, ready and complete to be fitted into cabinets. From the cheapest to the best.

SOUND BOXES

for Gramophone or Edison Cut Records.
First-class workmanship.

TONE ARMS

For Horn and Hornless Machines.
To fit all size cabinets.

40 DIFFERENT
MODELS

COMPLETE TALKING MACHINES

WITH AND WITH-
OUT HORN

Apply for Catalogues



Piccolo is a complete Talking Machine. Easily to be carried like a portmanteau. Most suitable for picnic or rover parties in summer, and easily carried to social gatherings in winter. Plays 12-inch records. Is not a toy. Weight without records only 5 kg. Measurements: 11x13¼x7¾ inches.

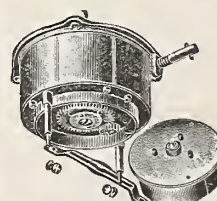

Special Motors HYDRA SYSTEM

Single and double spring, 6 different models. Are the only existing construction which allows the exchanging of the spring and spring case without taking the motor out of the cabinet. After loosening one nut, a child is able to replace any defective spring or springbox within 20 seconds.

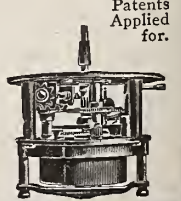

Patents
Applied
for.

ST. LOUIS TRADE GIVES GOOD ACCOUNT OF ITSELF.

Because of Excellent Volume Despite Extraordinary Heat and Talk of Business Depression—Month's News Record One of Advance with All Leading Concerns Who Are Doing a Good Business or Planning for Immense Activity During the Fall Season.

(Special to The Talking Machine World.)

ST. LOUIS, Mo., June 10.—The talking machine business is giving a very fair account of itself despite the extraordinary heat, the dry weather and general depression that is affecting all other lines and is making so many business houses hustle to equal totals of the current months of previous years.

Not so with the talking machines. The month's totals look better each month as compared with a year ago, and the business generally appears on a sounder basis than ever before, despite the new comers who might be expected to split the trade in many directions. The Victor jobber, the Aeolian Co., and the Koerber-Brenner Music Co., report a very satisfactory business, as to the Columbia wholesale departments and the Silverstone Music Co., of the Edison. The retailers have grasped the summer trade idea, that it must be gone after in the homes, on the porches or lawns, or at the clubhouse, wherever people are amusing themselves, but that is ready. Most dealers agree with Manager Robinson of the Thiebes Piano Co., that the summer trade, even that for the clubhouses and canoes, is of a higher class than ever before. That where \$15 and \$25 machines were in demand in previous years, \$40 to \$50 is the average investment this year.

Mr. Robinson printed a very attractive drawing in connection with a House of Thiebes ad. the first Sunday of this month. It presented the prow of a motor boat, with a talking machine dispensing music to the great gratification of the young man and woman seated in the boat. The head of the ad. was "Don't fail to take a Victrola, new Edison (diamond disc) or a Columbia gramophone with you on your summer outing." Mr. Robinson says the ad. has been an excellent puller and many of the later inquiries were traced directly to it.

The fact that the Thiebes Piano Co. has the three machines and offers a trial of all three side by side, the same numbers and in the same demonstration room, has been an excellent card for this firm. "Every time a single line dealer knocks a machine that he does not handle, it is a boost for our ads," says Mr. Robinson. "It is easy to make a prospective customer suspicious, and nowadays practically every purchaser knows the names of the three machines, and if the salesman says anything

to make them suspicious, he comes where he can hear all of them. We let them choose, and we often get much interested in watching to see which way the choice is going to fall. It is very difficult to predict until the sale is closed."

The Field-Lippmann piano store also have the three machines on exhibition, but they have not made the comparison idea as strong as the Thiebes Piano Co., in their advertising.

Alex Robinson, at the Grand Leader department store, reports some excellent business along the summer lines.

W. C. Ligon, who was in charge of the talking machine department at the Famous-Barr department store, has been transferred to the piano staff and Miss Elizabeth Vandeventer is in charge of the talking machines, under the direction of James B. Campion, of the piano department. Miss Vandeventer, who was in charge of the Victor department at Bollman Bros. Piano Co. for a long time prior to the failure of that company, is well known to the local trade.

Recently the Famous-Barr has been giving dual recitals with Victrolas and Edison disc machines, and Mr. Campion says that it is interesting to watch the conclusions reached by persons who hear the two machines under exactly similar conditions, and what peculiar advantages that go to make the sales.

The Columbia warerooms here were in sad disarray for three weeks, beginning May 20. The delayed work of remodeling the building was then begun in earnest, and one of the first things the working men found necessary was to tear out the demonstration booths and oust the office force, including Manager Irby Reid. The latter found refuge in the stockroom, which is apart from the main warerooms. Retail Manager Duffy remained on the job, sometimes here and other times there, wherever the workmen did not want to be. He had stock for three demonstration rooms near-by, and grouped his machines just as though they were surrounded by walls, and did the best he could under the circumstances. He spent most of his time planning stunts for the sales force, that would keep them and their prospective customers away from the store, but still bring in some business. Under the new plan, the retail department will have six demonstration booths and almost double

the machine display space as previously, and much better arranged. The entire main floor will be thrown together or divided by glass partitions, the office force having smaller but more workable quarters than before. The dictaphone department, which formerly held forth near the front door, will go to the second floor, where a large stock room will be arranged on a scientific plan. The changes include a convenient stairway to the second floor, new ceilings and complete new decorations for the entire building, and greatly increased light throughout the building. Mr. Duffy says:

"Without the shadow of a doubt we are going to have the handsomest talking machine store in this section of the country. We are staying right on the job while the duty is being added and we are taking care of all of our trade, but we cannot do much of the initiative under our present handicap. By the middle of this month we will have a worthy home for the Columbia, and then we will go abroad and invite everyone in to see our home and our machines, and to listen to the music and, of course, buy to meet their requirements."

New dealers added to the Columbia list are: J. M. Cline, druggist, Marion, Ill.; W. J. Fitzgerald, hardware, West Frankfort, Ill.; Busy Bee, candy, Shelbyville, Ill.; L. Shaver, Paris, Ill.

George Brown, Jr., of Hillsboro, Ill., has gone into the talking machine business on rather extensive lines for a small city dealer in this section. He is selling Columbias and Edison disc machines. He intends to thoroughly cover his community, and has established branches in the small towns and villages where one or more machines will be on demonstration, and he will be at call if the local salesman needs aid or different model machine than in carried in stock there. J. J. Bennett, of the Columbia sales force, was recently over the local territory with Mr. Brown, spreading cheer and confidence among the salespeople. Mr. Bennett says that with an automobile, such as Mr. Brown will use, any person who believes in talking machines can stir up a wonderful business in the country, for the farm homes are all open to some such intelligent entertainment as the talking machine brings. Mr. Bennett predicts that within a few years every county in the Middle West will have at least one energetic dealer who will cover the country districts and will make an excellent revenue from his work.

Only a few years ago the talking machine furnished the excuse for a piano house to keep open Saturday afternoons and late each evening, the idea being that the wage earners who bought talking machines as substitutes for pianos, organs or other high-priced music instruments, could not get in at other times to pay on their accounts.

This year, when the summer closing movement was started, no such excuses were presented. Instead, the leading talking machine stores are the leaders in early closing. The Field-Lippmann piano stores, Thiebes Piano Co., and Aeolian Hall were the first three to agree to close Saturday afternoons and at 5 p. m. during June. The Silverstone Music Co. moved up to 5.30 for June.

DISPLAYS OLD-TIME MACHINE.

Berliner Gramophone of the 1899 Model Compared with Modern Victrola XVI. in Window of Benj. Switky's Store.

Much attention was recently attracted to the show window of the store of Benj. Switky, the prominent Victor distributor at 9 West Twenty-third street, through the display in juxtaposition of one of the first of the old Berliner gramophones, placed on the market in 1899, and a modern Victrola XVI. The presence of the Victor dog added much to the effectiveness of the display, and suitable signs told just what the old machine represented as compared with the latest Victrola.

A merchant's success depends much upon his knowing the profitable sellers. It may be easy to sell nails, "but what's there in nails?" It may be good business to make every effort to increase your volume of business, but "what's in the volume" if you are selling mostly articles that are sold at a low or cut price?

Special

Send for a package of our Improved Half-Tone and Loud Tone Needles in New Style Envelopes.

If you want to advertise yourself, we will put your own name or trade-mark on the envelopes, or will pack in Puritone envelopes.

Quality Guaranteed

The Best Needles mean profit and satisfaction.

If you want to sell 1,000 Needles at a time instead of 100, use the "Dean-packed" Needles. Five boxes of 200 each, Extra Loud, Loud, Opera, Medium and Soft packed in a carton. The best package and fastest seller on the market. Write for samples.

JOHN M. DEAN, CORP.

Talking Machine Needle Manufacturers

PUTNAM, CONN.

SERVES NOTICE OF LEGAL ACTION BEING TAKEN.

Suit for an Injunction and an Accounting Filed Against Thomas A. Edison, Inc.—Claimed That Disc Machine and Attachments Infringe Victor Patents—Warning Against the Handling of Records Labeled to Imitate the Red Seal Records.

The Victor Talking Machine Co. sent out to its representatives recently a letter giving information relative to certain legal action which it is contemplating, portions of which are appended:

"It becomes our duty to notify the trade and the public generally that the Victor Talking Machine Co. has filed a suit for an injunction and an accounting of profits and damages against Thomas A. Edison, Inc., under the United States Letters Patent Nos. 785,362, 814,786 and 1,060,550, issued to and owned by the Victor Talking Machine Co. This suit was filed in the United States District Court for the Southern District of New York on April 29, 1914, Equity No. E 11/190.

"In this suit against Thomas A. Edison, Inc., for infringement of the letters patent enumerated, we contend not only that the disc talking machine manufactured and sold by that company is an infringement, but also that the attachment manufactured and sold for use with the Edison disc machine by which Victor records may be played thereon is also an infringement.

"Not only attachments supplied by the Edison Co. itself, but other attachments made and sold by other parties, hereinafter referred to, for use upon the Edison machine by means of which Victor records may be played thereon clearly infringe, among others, the letters patent above referred to.

"Under the letters patent owned and controlled by the Victor Talking Machine Co. it is contended all disc records of the gramophone type (laterally undulating or zigzag groove), all Victrola types of machine, and all taper tone-arm constructions now upon the market come under the claims of the letters patent enumerated and others owned by

this company, and there is an apparent tendency of increasing activity in such infringements, which will be dealt with as the occasion requires.

"The companies referred to which have been notified of the infringement of certain of the Victor Co.'s letters patent are as follows: Crescent Talking Machine Co., 106-108 Reade street, New York, N. Y.; Diamond Talking Machine Co., 401 Prospect avenue, N.W., Cleveland, O.; Independent German-American Talking Machine Co., 155 East Fourth street, New York, N. Y.; A. F. Meisselbach & Bro., Newark, N. J.; New England Talking Machine Co., 132 Boylston street, Boston, Mass.; F. H. Thomas Co., 689 Boylston street, Boston, Mass.; Triton Phonograph Co., 41 Union square, New York, N. Y.; Union Specialty & Plating Co., 409 Prospect avenue, N.W., Cleveland, O.; United Patent Co., 75 Fifth avenue, New York, N. Y.; Unit Motor Co., 108 Worth street, New York, N. Y.

"Recently there have also appeared in the United States gramophone disc records of the Victor type, both from Europe and from Japan, having red labels thereon. These records not only infringe the Victor Co.'s letters patent, but also this company's trade-mark No. 49,364, registered January 30, 1906, in the United States Patent Office. This registration covers the exclusive right to the use of the trade-mark consisting of a red disc applied to the center of a talking machine record. Therefore, all who handle or use these records so having the red disc are also infringing this company's exclusive trade-mark, and suitable warning is hereby given of such infringement to the trade and public generally."

NOTICE FROM THOMAS A. EDISON, INC.

Issues Answer to Circular of Victor Co. Announcing Suits for Infringement of Patents—Deny Claims Made by Plaintiff Company.

Thomas A. Edison, Inc., Orange, N. J., under date of May 26, issued the following notice to the talking machine trade:

"Our attention has been called to a circular issued by the Victor Talking Machine Co., under date of May 20, and addressed 'To the Trade.' It contains a statement to the effect that the disc phonographs and attachments for playing lateral cut records put out by this company are infringements of three United States patents upon which suit has been brought against this company in the United States District Court for the Southern District of New York.

"We wish to assure the trade that a careful examination of these three patents has been made by our patent counsel and that in his opinion there is no basis whatever for any charge of infringement by reason of the use or sale of our apparatus. Jobbers and dealers should not be alarmed or mis-

led by any circularized statements of this character, and in case of any suit being brought against them or of any threats being made, they should immediately communicate with us. We stand ready to assure the defense of any patent suit brought against any jobber, dealer or user based upon the sale or use of any of our disc phonograph apparatus. Yours very truly,

"THOS. A. EDISON, INC.,
"C. H. Wilson, Vice-President."

MOVE TO LARGER QUARTERS.

The Newark Talking Machine Co., of Newark, N. J., has removed just next door to its former location, corner Broad street and Central avenue, to much larger elaborate quarters, having four large demonstration booths and one large display room. M. Buchner, president, and Chas. Buchner, treasurer, report an excellent volume of Victor business with their house.

Some men are so wise that it seems as though they must have been born at a much earlier age than the rest of us.

COULDN'T SELL THE RECORDS.

Maxwell Corkedale Could Give Away Talking Machines, but the Records Proved White Elephants—Settles Suit with Company Who Started the Plan—So Ends the Tale.

(Special to The Talking Machine World.)

NEWBURGH, N. Y., June 6.—After being out less than an hour last week the jury in the action brought by Thomas F. Johns, doing business as Harmony Talking Machine Co., against Maxwell Corkedale, decided that if Mr. Corkedale would pay to the plaintiff the amount he claimed and admitted he owed to the company it would satisfy the ends of justice. Mr. Corkedale had accepted representations of an agent of the talking machine and then signed a document calling for the shipment of goods. The first shipment was valued at \$61.85, and a year's interest will go with it. As Mr. Corkedale had tendered the amount prior to the case coming to trial the costs will fall on the plaintiff, and there will be small chance of meeting expenses out of the case.

Corkedale, who runs a store in this city, made a contract on June 24, 1912, with B. Blankman, representing Thomas F. Johns, who was doing business under the title of the Harmony Talking Machine Co., of Chicago, Ill., whereby Corkedale became agent for the company in this city. The machines were to be furnished in dozen lots and to be given away as prizes when buying goods to the value of \$35 or more. The profit was to be made in selling records to those who received the machines, the records to sell at 65 cents and costing the agent 39 cents. The needles and other accessories were also to be sold. All goods were to be paid for in thirty days after delivery. The first shipment included a machine, carton of records and needles, etc., to the amount of \$23.15, and shortly after there came another shipment of a dozen talking machines and twelve cartons of records, valued at \$234.

Corkedale testified that he had not ordered these and had sent them back after finding there was no sale for the records. After having given the first machines away he found that people would not buy records at 65 cents.

The settlement effected was for the goods received under the first bill, supplemented by other articles disposed of from the second shipment, the total value of all being \$61.85.

MISS EDISON TO BE MARRIED.

The marriage of Miss Madeline Edison, daughter of Mr. and Mrs. Thomas A. Edison, and John Sloane, son of Dr. and Mrs. T. O'Connor Sloane, will take place on Wednesday afternoon, June 17, at the home of the bride-elect's parents. The wedding promises to be one of the social events of the season.

NEW CONCERN IN BUTTE, MONT.

The Butte Phonograph Co., composed of Joseph Lutey and L. V. Williams, has opened an exclusive talking machine store in Butte, Mont., where Edison products will be handled.

**"DOLLAR" MOTORS**

LATEST SENSATION—DETACHABLE SPRING CAGE

Without any dismantling of the motor, a NEW SPRING may be inserted within a few seconds.

Many patents both at home and in every civilized country applied for.

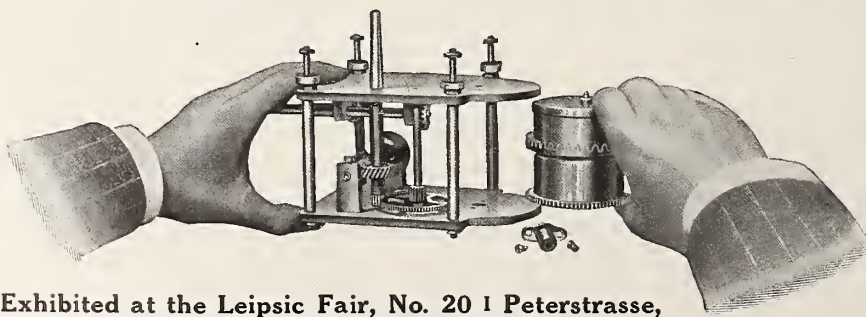

Exhibited at the Leipsic Fair, No. 20 1 Peterstrasse, Hotel de Russie, Zimmer No. 6.

GEBRÜDER STEIDINGER, Fabrik für St. Georgen (Schwarzwald), Deutschland

Cable Address: Gebrüder Steidinger Sanctgeorgenschwarzwald.

ARE UNQUESTIONABLY THE BEST AND CHEAPEST

Our Export Catalogue in four languages, covering 30 styles of motors adapted for Talking Machines, sent free of charge, postage prepaid, for the asking.

Advantages of our Motors:

Noiseless movement
Supreme accuracy
Highest grade of materials
Greatest money value

"TALKER" AND PLAYER COMBINED. GAIN OF 35 PER CENT. IN BUSINESS.

Two Furniture Men of St. Louis Evolve a Simple and Practical Combination of the Two Popular Instruments—How the Desired Result Is Obtained Interestingly Described.

(Special to The Talking Machine World.)

ST. LOUIS, Mo., June 6.—The very simple and practical combination of player-piano with talking machine which is here reproduced is the invention of Isadore Fry and Jacob Shanks, two young furniture men of this city.

It has been prophesied that when a successful combination of these two instruments was made it would be by some one outside of the music trade,

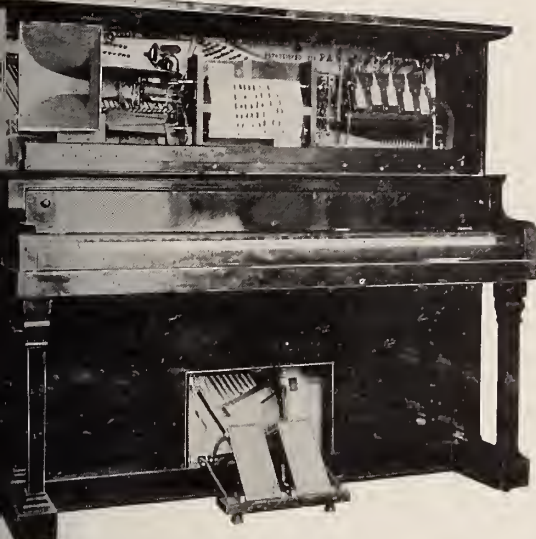

Showing Operation of the Player and the Talking Machine.

and the simplicity of this instrument, together with its accurate synchronization, makes this seem true. The talking machine is operated by the same motor as the player and receives its power by means of a delicately adjusted sprocket wheel and chain located on the left side of the lower spool. A clutch is also provided whereby the talking machine may be thrown into gear or not as desired. Either machine may be worked separately.

The bellows are adjusted to carry the additional



Showing Outside of Instrument.

load in a novel way. The sound box of the talking machine sits back in the piano, close to the plate. The aperture or bell of the machine is brought out on the left-hand side of the upper panel as shown in the picture.

The inventors claim this machine can be installed in an hour's time in any piano that is of ordinary depth.

CLEANNOTE PAD saves tunes, talks. Improves tone. Lessens scratch. Trebles life records. 25c. Get circular. Agents wanted.

VOX HUMANA TALKING MACHINE CO.
Nantucket, Mass.

This Is the Record of Louis Buehn, of Philadelphia, in Comparing Business with the First Five Months of This Year with the Same Period of 1913—An Invitation to Jobbers Visiting Atlantic City to Make His Place Their Headquarters.

(Special to The Talking Machine World.)

PHILADELPHIA, PA., June 9.—In a chat with a representative of The Talking Machine World, Louis Buehn, Victor jobber of this city, made the very interesting statement that, notwithstanding the business transacted by him, last year was the largest in its history; that the first five months of this year in comparison had shown a gain in volume of business of approximately 35 per cent. This is a remarkable increase, and simply shows what can be accomplished in this day of commercial activity when the pessimist is about with his large pitcher full of cold water.

Mr. Buehn aims first to co-operate with the retail merchant, and naturally this assistance on his part so pleases the trade that it is their endeavor to use every means to aid him in maintaining the co-operative service that the house of Buehn is noted for.

Mr. Buehn is planning to attend the convention at Atlantic City, and in this connection he invites all the visitors to drop in and see his establishment at 825 Arch street, in this city, which is in a very convenient location, and in addition Mr. Buehn would be pleased to have the visitors use his office as their headquarters while in this section.

MACHINE TO DETECT SOUNDS.

New York Inventor Thinks Device Will Prevent Sea Collisions.

Elias E. Ries, an electrician and inventor of 116 Nassau street, wrote recently to President Wilson asking his aid in getting a Government test of a sound detecting apparatus, which Mr. Ries believes will enable ships at sea to find the position of icebergs or any approaching object by means of echoes long before it has come into the range of normal hearing. This apparatus, Mr. Ries thinks, would have prevented the "Empress of Ireland" disaster.

The principle of the system, which is now before the United States Patent Office, is the same as that of human hearing, only the mechanical ears are microphones at either end of a long arm attached to the mast of a ship. This arm moves about and explores sound waves reaching it, and when the sound in both receivers is of equal intensity a special device, the inventor says, reckons the exact distance and direction of the object from which the sound comes.

The receivers are connected with ear pieces for the ship's lookout and also for the captain. At the bow of the boat the ordinary siren sends out its sound waves and it is the echo from these that the lookout waits for. With ordinary sounds a man instinctively turns his head until the sound wave strikes equally on both ear drums. The long arm with the receivers on it has length enough to fall into the circle of the sound wave from afar and when this has been exactly accomplished, Mr. Ries says, a device shows the distance without any reckoning on the part of the lookout.

A STARTLING INSCRIPTION.

A traveling salesman died suddenly in Kalamazoo and his relatives telegraphed the florist to make a wreath, ordered that the ribbon should be extra wide with the inscription, "Rest in Peace" on both sides, and if there was room, "We Shall Meet in Heaven." The florist was out of town and his new assistant handled the job. It was a startling floral piece which turned up at the funeral. The ribbon was extra wide and bore the inscription, "Rest in Peace on Both Sides, and If There Is Room We Shall Meet in Heaven."—Sel.

Benjamin Franklin undoubtedly possessed the best organized mind that history records. How his master mind was organized is interestingly told in his autobiography.

A Great Business Opportunity

Are you looking for opportunities to increase your net profits?

Are you interested in lines which blend satisfactorily with talking machines which will add materially to your business success?

If you are, we can help you, and the sooner you get in communication with us the more rapidly your profits will accumulate.

Do you realize how splendidly pianos and player-pianos blend with talking machines?

We have created one of the largest manufacturing enterprises in the world in a short space of time, and we have done it through the delivery of values.

We are in a position, through our unexcelled factory facilities, to supply you with pianos and player-pianos at prices which will enable you to make splendid profits.

Our instruments are reliable in every particular, and our prices will appeal to people of moderate means.

Let us take up this subject with you.

It will pay you!

H. P. NELSON COMPANY

Makers of Grands, Uprights and Player-Pianos

North Kedzie, North Sawyer, West Chicago Aves. and C., M. and St. Paul R. R., CHICAGO.



Columbia instruments: a line to fit the pocketbook of every possible buyer of a talking machine. Columbia records: a line from which every dealer can meet the musical preferences of anyone who owns a talking machine.



(Write for "Music Money," a book "full of meat" for those dealers interested in quick and frequent turnover of capital.)

Columbia Graphophone Company
Woolworth Building, New York

MY FRIEND THE DEALER PUTS OVER A FEW NEW ONES.

An Informal Interview in Which a Prominent Talking Machine Man Suggests Some Timely and Remunerative Stunts for the Good Old Summer Time—A Mexican War Record Wanted—Some Hints Relative to Revitalizing the Art of Home Record Making.

It was deliciously cool and quiet in the sanctum of John Jones, The Elite Talker Shop proprietor, after the heat and hubbub of the street, and I sank into the easy chair he pushed toward me with a sigh of contentment. An electric fan purred above his desk and an iced jar of spring water, aglitter with moisture, reposed invitingly at his right hand. It was an ideal place for the making of big business and I told Mr. Jones as much.

He shrugged his silk-shirted shoulders and smiled.

"There are two things most essential to me in the manufacture of my trade ideas, viz: comfort and quiet. The brain works fastest when the body is at rest and when there are no jarring discords of sound to divert the attention."

He looked at me inquiringly: "Is The Talking Machine World representative seeking an interview, I wonder? and will he have a cigar?"

"He is and he will, and he thanks his hospitable host very kindly."

A moment of stillness, broken by the scratching of our matches, then Mr. Jones asked another question: "How can the present situation in Mexico be turned to account by the 'talker' man?"

"I would be charmed to have you tell The World readers about it," I replied feelingly.

With a puff at his weed, he continued: "Well, I have been indulging, along with the scholarly Woodrow, in a policy of watchful waiting. I have eagerly watched the monthly bulletins and I have waited most impatiently for a special announcement from one or even all of the great triumvirate regarding a series of records describing the capture of Vera Cruz, the funeral of Poinsett, etc. The demand for records celebrating events of this character is enormous. My customers ask me every day why such selections have not yet been issued. I have invariably told them that they have only to be patient for a little while and their wishes will be gratified. Let us pray that this is true.

"Please ask the manufacturers for me through the columns of The World to bring out a "Capture of Vera Cruz" record at once; I need it in my business."

He laid his cigar in the ash tray and leaned forward in his chair: "Let us go back to the time of the Spanish war. Do you remember the records made by the chief bugler of Roosevelt's Rough Riders?"

I nodded an affirmative.

"The calls played over the graves of Hamilton Fish and Captain Capron, and marketed by what was then the Columbia Phonograph Co., of New York and Paris, were wonderful sellers; I couldn't get enough of them. "The Capture of Santiago" and "The Charge of Roosevelt's Rough Riders," put out by the same company, made pronounced hits also.

"There are several ways in which our present misunderstanding with Senor Huerta can be suc-

cessfully utilized by the talking machine dealer, and it is a great surprise to me that a movement of this kind has not been started ere this."

Mr. Jones reached for his dead cigar. He relighted it with much care and leaned comfortably back in his seat, sending smoke rings ceilingward.

"Now that Miss Margaret Woodrow Wilson is singing into the horns, would not a record of her voice in "La Paloma" create a sensation?"

More smoke rings.

"I can see the advertisement now:

Mexico's Most Popular Song

La Paloma, The Dove

Sung by America's Most Prominent Vocalist
MISS MARGARET WOODROW WILSON

Daughter of the Nation's Chief Executive
"Some combination, what?"

"The talking machine business should be con-



"Taps."

ducted along the same lines as a newspaper, so far as taking care of unusual occurrences is concerned. Just as a city daily indulges in extra editions to keep its readers posted upon the latest developments of a war, so should the 'talker' manufacturer get out special descriptive selections recorded with care and brilliancy. A representative should be sent to the front if necessary in order that the records may be faithful reproductions of the real conflict"

"Are you sure it would pay to go to that extremity, Mr. Jones?" I asked skeptically.

"My dear boy, there is no doubt about it. If the public had reason to believe that the records

were echoes from a genuine and bloody war, and not imitations concocted from the barren imagination of a laboratory manager, they would fall over one another like suffragettes in an art gallery to get them. Oh, yes, they'd sell all right, believe me."

Opening a drawer of his desk he drew forth a magazine and handed it to me.

"Ever go in for photography?" he inquired.

"Yes, I'm exceedingly fond of it, why?"

"That copy of Popular Photography, which, by the way, is a corking good periodical for the amateur picture maker, gave me an idea. If you will turn to the editorial page you will learn that they offer monthly prizes for photographs. Glancing through the pages you will find from the generous amount of worthwhile pictures displayed there, that the contest is exceedingly popular and widely patronized. Such being the case, why would it not pay a talking machine dealer to inaugurate a prize recording contest? For the purpose of boosting home record making, it seems to me this scheme is a winner, and I wonder why this also has not already been done.

"Every live 'talker' man has a fat list of patrons who have machines which will record. What will stimulate their interest like asking them to sing, play or talk for a prize? Offer them whatever inducement you deem consistent with your business and your pocketbook and watch the shaving machine whirr and the stock of blanks melt away.

"Mention the contest in all your advertising matter. Everything in the line of publicity that leaves your store should talk about the contest."

"Are you trying it out?" I asked curiously.

"Uh huh! Stop in the packing room on your way out and you'll think so.

"Just a moment"—as I rose to depart—"and I will explain with becoming brevity how I conduct my recording contests. I leave the choice of selection entirely to my patrons. I simply state that the record must be made with an apparatus purchased from me, and that a prize of \$5 will be paid each month for the record which seems from every possible standpoint to be the best. A committee of three, selected from my sales force, judge the records and make the awards. You see, home recording is a very fascinating pastime; especially when there is the possible chance of making something out of it in the way of a small financial return. The element of honor also enters in to a small degree, and it is very satisfying to Mr. Record Amateur to know that his success as a 'talker' artist is worthy of a prize.

"When the scheme is put into effect by several dealers, thus increasing the market for amateur records, the demand for blank cylinders and recording outfits will soar by leaps and bounds."

How about this contest idea, Mr. Dealer? Worth a thought or two, is it not?

HOWARD TAYLOR MIDDLETON.

CHEMISCHE
FABRIK

E. SAUERLANDT

FLURSTEDT
bel Apolda i. Th., Germany

The largest manufacturing plant in the world devoted exclusively to the manufacture of Master-Waxes and Master-Blanks for

Gramophone and Phonograph Recording

Sole Manufacturer of Wax "P." the best recording material for Berliner-cut.

DETROIT DEALERS LOOK FOR A VERY BUSY FALL

Following a Lively Summer Season with Its Demands for Dance Records—Hudson Co.'s Talking Machine Department—Max Strasburg Co. Completes Alterations—General Conditions Analyzed with Favorable Conclusions—Developing Near-by Territory.

(Special to The Talking Machine World.)

DETROIT, MICH., June 8.—Though May was a quiet month in the talking machine business in Detroit, the dealers have every reason to believe that a revival is close at hand. The summer months always are good ones in Detroit, because of the extensive summer resort facilities of the city. The present-day propensity of all dancers to dance to talking machine music is expected to add to the normal summer activity in the trade. Dance music will get into many a summer home on lake shore and island where it hitherto has been unknown because orchestras are too expensive. It also will be heard at hotels and aboard yachts. Very few yachts, and only the largest ones, ever have orchestras aboard, but many of them have enough deck room for dancing. And dancing afloat is the most enjoyable kind.

March and April were good months, and there is no particular reason for the falling off in May. This is taken as further ground for belief in a prosperous summer. Collections are good. Selling terms also remain good there seeming to be plenty of cash in evidence when a purchaser discovers that he can save 6 per cent. by using it. Basic business conditions in Detroit are good, this being evidenced by the tremendous activity in the building trades. People are building their own homes in newly created suburbs. Temporarily, this may affect the talking machine business, for the home builders will need their spare cash for real estate payments, but eventually thousands of them will want phonographs in their new homes.

Detroit now extends along Detroit River and the shore of Lake St. Clair for a distance of thirty miles, and all along the east, west and north city lines new subdivisions are being built up. This gives employment to an army of many thousands of workmen, with the resultant increase of purchasing power. Still there are idle men here. But most of them are outsiders who came here in search of prosperity.

The talking machine department of the J. L. Hudson Co. now is in new quarters on the seventh floor of the main building of the company, there to remain until the completion of a new ten-story building next November, one of the principal fea-

tures of which will be a grand music trades department. There the talking machines will have an entire floor.

For the present the Victrolas and the Grafonolas are adjacent to the pianos, but have an elevator entrance of their own. The record cases are with them, placed in a very handy arrangement. While the main body of the music trades department is finished in ash gray, the talking machine division is made distinctive by white enamel.

The Hudson Co. is laying in a very large stock of machines, following the policy of last year, which protected it from the annual scarcity of



Exterior of Max Strasburg's Establishment.

machines at Christmas time. More will be needed than can be accommodated in the present quarters, but they will be brought to town and stored until the doors of the new store are thrown open. The company, with millions of capital, has promised Manager Andrew that his department shall be one of the finest talking machine stores in the United States.

The Max Strasburg Co. recently completed alterations which make this exclusive Victrola and Columbia shop finer than ever. The accompanying photograph shows the exterior of the store. The many plate glass partitions between the demonstrating rooms queered all efforts to make a picture of the interior, the refraction of light on the glass making more scintillations than the camera could stand for. The automobile, used for delivery of talking machines and records, is one of the additions to efficiency instituted by the company.

The store is a corner one, with entrances on two streets. The rows of Victor dogs in the windows show the extent of it. The Victrola electric sign is not as prone to partiality as would seem, as it says "Grafonolas" on the other side. The store is a

deep one as well as a wide one, extending back 100 feet from the street. The entire basement has been divided into demonstrating rooms. Only two years and a half have passed since it was established, and its growth has been truly wonderful. It caters to a very high class of trade. This is what made the automobile necessary. Regular patrons 'phone their orders for records. Each day these orders are routed and filled in the same manner big mercantile houses handle their various lines of goods. The records are sent on approval, selections to be made within twenty-four hours. This system has made the record end of the business very profitable for the Strasburg Co.

The extension of the number of Detroit accounts seems to have ceased for the time being. The city is about as well covered as it can be, though incipient outlying business districts soon will open up new fields for agencies.

NEW EDISON AGENTS APPOINTED

In Various Points Adjacent to New York City—Edison Output Grows.

Thomas A. Edison, Inc., is continuing to add many new names to its already extensive lists of Edison disc dealers in near-by territory. During the past month a number of live-wire dealers arranged to handle Edison disc machines and records, including the following: W. B. Thompson, Port Richmond, S. I.; Louis Barg, Bay Ridge, Brooklyn; and Dutcher Bros., Nyack, N. Y.

All of these new representatives are enthusiastic admirers of the Edison disc product, and are planning to conduct their Edison departments on lines entirely in keeping with the musical value of the Edison disc machines and records. These products are increasing in popularity rapidly.

LOSS BY FRAUDULENT FAILURES.

Statistics show that manufacturers and jobbers lost more than \$2,000,000 last year in questionable, if not fraudulent failures. This loss has shown such a marked increase each year that the National Association of Credit Men and other organizations undertook the work of investigating many of these failures with the view of punishing the guilty, as a warning to others inclined in that direction, and thereby stop the growth of the losses on this account and get them back to a nominal figure. That this work has been successful is evidenced by the fact that only a few months ago a gang engaged in this work on a large scale, with headquarters in St. Louis and branches in five other large cities extending as far East as Baltimore, were rounded up through the work of these associations and convicted. The evidence showed that the gang in six or seven months prior to their apprehension defrauded creditors out of more than a half million dollars. These prosecutions also will tend to benefit the small, honest retailer in more ways than one. So society generally will be benefited by reducing this practice to the minimum, or stopping it entirely, if possible. Wide publicity by newspapers of such prosecutions is the best means possible for educating those inclined to this practice of the folly of their ideas.

HERMANN THORENS, Ste. Croix (Switzerland) TALKING MACHINE WORKS

Motors and Sound Boxes a Specialty

CONCEDED TO BE THE BEST MANUFACTURED

OVER THIRTY DIFFERENT STYLES

Machines with or without Horns

FIRST QUALITY ONLY

Noiseless Motors

HIGHEST RECOMMENDATIONS

WRITE FOR DESCRIPTIVE CATALOGUE

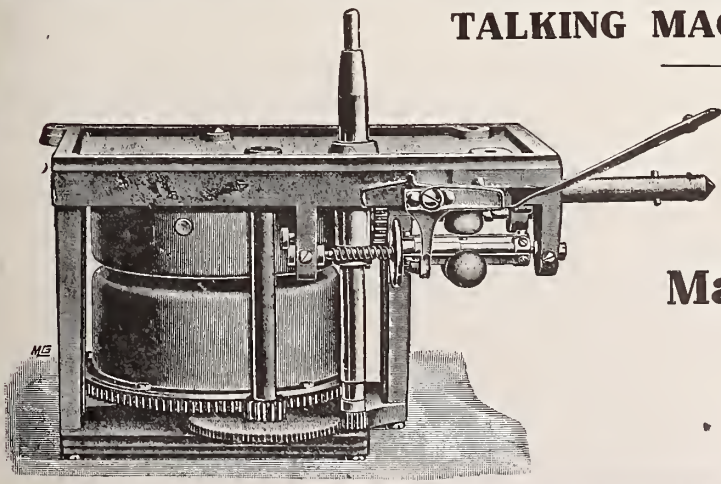

LATEST PATENTS RELATING TO TALKING MACHINES AND RECORDS

(Special to The Talking Machine World.)

WASHINGTON, D. C., June 8.—PHONOGRAPHIC DOLL.—William Rotter and Richard S. Arthur, Newark, N. J. Said Arthur assignor to said Rotter. Patent No. 1,097,771.

The objects of this invention are to provide a doll in which sound reproducing apparatus is arranged so that the doll will appear to talk; to obtain the issuance of sound from the proper part of the doll's body; to enable the sound reproducing apparatus to be conveniently operated and controlled, and records to be readily and easily changed; to arrange the parts of the apparatus so that they will not be easily tampered with; to provide means for retaining the record drum in idle position to receive the thrust required to insert a record; to provide improved means for releasing the feed nut from the thread bar when the record has been played; to provide improved means for returning the record to its initial position after having been played and the feed nut removed; to

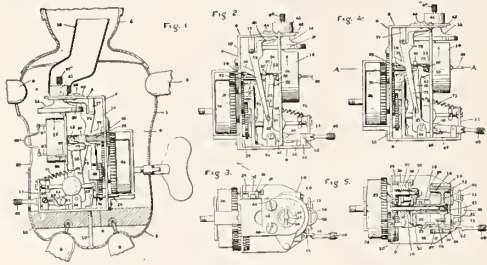

provide means for positively removing the sapphire from the record during the return of the record to initial position; to maintain the feed nut in true relation to the thread bar; to secure simplicity of construction and operation, and to obtain other advantages and results as may be brought out in the following description.

Referring to the accompanying drawings, in which like numerals of reference indicate the same parts throughout the several views, Fig. 1 is a central sectional view through a doll, looking from the back toward the front of the same, and showing our improved mechanism mounted therein;

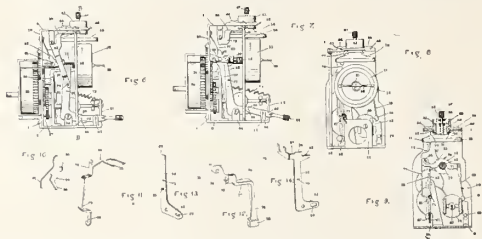
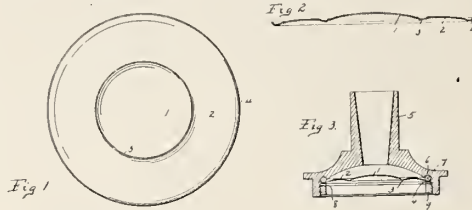

Fig. 2 is a view of said mechanism from the front with the doll body removed; Fig. 3 is a top view of the same; Fig. 4 is a view similar to Fig. 2, showing the operating lever partly depressed; Fig. 5 is a sectional view on line A—A of Fig. 4 looking down; Fig. 6 is a view similar to Fig. 2 showing a modified construction with a detent for holding certain levers while the record is being played; Fig. 7 is a similar view showing said levers engaged by the detent; Fig. 8 is an elevation looking from the right hand side of Fig. 6; Fig. 9 is a vertical sectional view taken on line B—B of Fig. 6; Fig. 10 is a perspective view of the detent for retaining said levers; Fig. 11 is a perspective view of the arm for raising the reproducer; Fig. 12 is a perspective view of the feed nut and its attached brake; Fig. 13 is a perspective view of a certain raising lever, and Fig. 14 is a similar perspective view of a locking lever.

DIAPHRAGM FOR PHONOGRAPH SOUND-BOXES.—Peter Weber, Orange, N. J. Patent No. 1,098,340.

This invention relates to diaphragms and has for its object the provision of a central stiff vibrating zone surrounded by an elastic, flexible, annular zone, and it has for its object the preservation of the clearness and distinctness of sound transmitted by the diaphragm as well as the obviation of the deflection of sound waves and their consequent interference with one another.

It also has for a further object the provision of means whereby the diaphragm may be properly centered within the sound box without contact with the metallic portions thereof.



These and other objects will appear from the following detailed description taken in connection with the accompanying drawing, wherein—

Fig. 1 illustrates a plan view of this improved diaphragm. Fig. 2 is a central or diametrical section of the diaphragm. Fig. 3 is a vertical section through a sound box showing the improved diaphragm in position.

HORN-SUPPORT.—Pliny Catucci, Newark, N. J. Assignor to A. F. Meisselbach & Bro. Patent No. 1,098,313.

The object of this invention is to provide a rigid, substantial support, to be secured to the motor plate of a phonograph, for carrying the amplifying horn, and also for supporting the sound box in a position adjacent the sound record to be played upon the instrument.

In the design patent No. 41,499 dated June 20, 1911, the inventor has shown substantially the same form of structure, and in his patent application

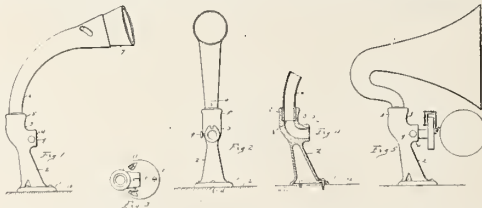

filed May 29, 1911, Ser. No. 630,170, he has shown similar horn supports, specially adapted to the purposes disclosed therein, and my present application may be considered a division of said application so far as it relates to common subject matter.

In the accompanying drawing Fig. 1 is a side elevation of the support. Fig. 2 is a front elevation. Fig. 3 is a plan view. Fig. 4 is a sectional view taken on line 4—4 of Fig. 2. Fig. 5 is a side elevation showing the support in connection with a well known form of horn.

PHONOGRAPH.—Charles S. Osborne, West Orange, N. J. Assignor, by mesne assignments, to New Jersey Patent Co., West Orange, N. J. Patent No. 1,097,987.

This invention relates to phonographs, particularly those adapted for commercial purposes, al-

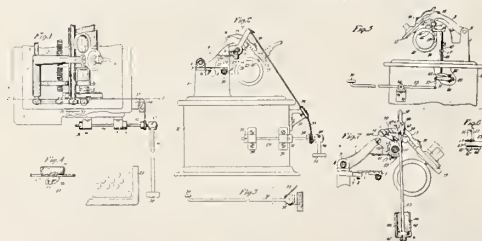

though obviously its use is not limited to machines of this type.

In transcribing a commercial record the transcriber frequently finds it necessary to repeat a portion of the record. It has accordingly been customary to provide commercial phonographs with mechanism whereby the carrier arm supporting the reproducer may be stepped in a rearward direction along the record as shown, for example, in U. S. Patent No. 847,631, granted on March 19, 1907, to E. L. Aiken. With devices of this character, however, as heretofore known and constructed, it has been impossible to place the controlling member for

the repeating mechanism in a convenient position for actuation by the transcriber while operating the typewriting machine.

The principal object of the present invention is to obviate this difficulty by providing means whereby the carrier arm may be readily raised and stepped in a rearward direction from a point in proximity to the keyboard of the typewriter or from any other desired point.

The invention also comprises certain other details of construction which will be hereinafter more fully set forth.

Referring to the accompanying drawing in which like parts are designated by the same reference numerals, Fig. 1 is a plan view illustrating a phonograph located in proximity to the keyboard of the typewriter and embodying one form of the invention; Fig. 2 is an end elevation partly in section on the line 2—2 of Fig. 1; Figs. 3 and 4 are elevations illustrating details of construction; Fig. 5 is an end elevation of a modification; Fig. 6 is a plan view of a detail of construction employed in the modification shown in Fig. 5; and Fig. 7 is an elevation partly in section of another modification.

PHONOGRAPH-REPRODUCER.—Adolph F. Gall, West Orange, N. J. Assignor to New Jersey Patent Co., West Orange, N. J. Patent No. 1,097,972.

This invention relates to phonograph reproducers of the Edison type in which a floating weight is

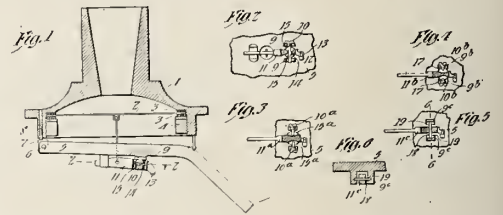

pivoted to the body of the reproducer, and the stylus is carried by a lever pivoted to the floating weight and connected to a reproducer diaphragm or other means for producing sound vibrations.

The invention has for its object the mounting of the said lever in such a way that the stylus shall be free to move up and down and also horizontally or laterally, but which mounting will not permit the stylus lever to move longitudinally or to turn about a longitudinal axis, whereby the stylus responds very readily to irregularities in the record groove, is adapted to track a record groove having a pitch as small as one two-hundredth of an inch or less, and produces at all times a loud and clear reproduction.

Reference is hereby made to the accompanying drawing of which

Fig. 1 is a central vertical section of a phonograph reproducer constructed in accordance with this invention; Fig. 2 is a section on line 2—2 of Fig. 1; Figs. 3, 4 and 5 are similar views of modifications, and Fig. 6 is a section on line 6—6 of Fig. 5.

FLEXIBLE JOINT FOR THE TONE ARMS OF TALKING MACHINES.—Alex Fischer, Kensington, London, England. Patent No. 1,097,618.

This invention refers to flexible joints for the tone arms of talking machines and has for its object the removal of the tendency to bind, that in joints for which the inventor obtained Letters Patent No. 879,755 has been found to occur between the convex portion of the flange attached to the moving member and the concave portion of the flange attached to the fixed member.

The flexible joint made according to the present invention comprises as in the previous case, two members, a fixed member in connection with the trumpet and a movable member in connection with the tone arm, but in place of providing curved flanges with their center of curvature on the same side of the joint as the moving member, the inventor provides a flange in connection with one of the members which flange is curved and has the center of curvature located on the same side of the joint as the fixed member, the other member being provided with a bearing surface corresponding to and concentric with the aforesaid flange and being in addition provided with parts extending beyond and around the edge of the flange carrying means coming on the other side of the flange to keep the flange and the corresponding surface in contact.

In one way of carrying out the present invention,

LATEST PATENTS RELATING TO TALKING MACHINES—(Continued from page 56).

in place of providing a convex flange on the moving member coming between two flanges attached to the fixed member, the inventor provides the fixed member with a convex flange, such flange being convex at the outer and concave at the inner surface, the curvatures being both struck from the same center and also provides the moving member, that is, the tone arm, with two flanges curved so as to correspond to the inner and outer surfaces of the aforesaid fixed member and connected together so as to form a species of cap. The moving member is thus supported by the two flanges attached to it and enabled to move in conformity with the convex flange of the fixed member.

There may either be two flanges attached to the moving member coming directly into contact with the convex flange attached to the fixed member in a manner analogous to that described and shown in connection with Fig. 3 of the aforesaid specification, or balls may be employed coming between any of the bearing surfaces either resting directly upon

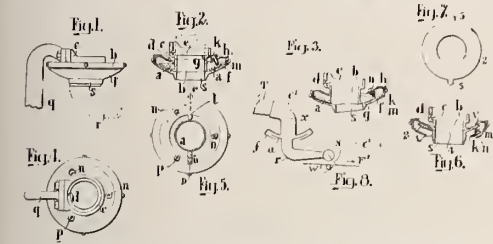

such surfaces or working in grooves therein. Where it is desired to adjust the balls screws are provided coming at the back of the balls, which screws pass through the cap. The directions in which the holes or grooves for the reception of the balls should be drilled shall be radial with respect to the center of rotation of the joint.

In another way of carrying out the invention the moving member is provided with a flange and the fixed member with two flanges forming a species of cap. In this case the center of curvature is on the trumpet side of the joint, corresponding alterations being made in the rest of the construction.

Fig. 1 shows side elevation of one form of the joint; Fig. 2 shows same in vertical longitudinal section; Fig. 3 shows similar view to Fig. 2, but with the moving member in its extreme position. Fig. 4 shows plan of Fig. 1. Fig. 5 shows plan of Fig. 2 with a portion cut by the line A B Fig. 2 in section. Fig. 6 shows sectional elevation similar to Fig. 2 of another form of the invention. Fig. 7 shows plan of a detail. Fig. 8 is a diagram of the essential features of the invention.

REPRODUCER FOR TALKING MACHINES.—Clinton E. Woods, Bridgeport, Conn. Assignor to American Graphophone Co. Patent No. 1,096,661.

This invention relates to reproducers for talking machines, and while the invention in some of its phases is applicable to the reproduction of either the vertically undulating or the laterally undulating style of record, the greatest benefits through its use are secured in connection with the laterally undulating or zig-zag form of record groove.

In many records there are portions in which the amplitude of vibration of the recorded sound greatly exceeds that of the main body of the record. So also in some records the amplitudes of the vibrations of the record taken as a whole greatly exceed those of other records in which the amplitude is comparatively small. Little difficulty is experienced in reproducing the sounds represented by the undulations of minute or of the average amplitude of vibration, but when the stylus bar is actuated by the undulations of great amplitude a sudden blow is struck upon the diaphragm, producing harsh and disagreeable reproductions, commonly referred to in the art as "blasts," and it is one of the objects of the present invention to provide a reproducer which shall avoid the "blasts" or harsh and foreign noises referred to. This is accomplished in the present invention by providing a connection between the stylus bar and the diaphragm which shall be sufficiently rigid and unyielding to transmit all of the smaller or more minute vibrations from the record to the diaphragm undiminished, which connection, however, is slightly yielding in character under the influence of a sudden or harder blow

which would be transmitted as the result of the stylus of the reproducer being actuated by the undulations of great amplitude. The result of this construction is that the blow which would be imparted to the diaphragm by the undulations of great amplitude is cushioned, thereby softening down the resultant note in reproduction, and avoiding the "blast" or harsh and foreign noise heretofore resulting from this cause.

It has heretofore been proposed in reproducers for talking machines to employ a diaphragm of metal, such as aluminum, having annular corrugations on the central portion of the diaphragm with radial corrugations extending from the annular corrugations out toward the periphery of the diaphragm. Such diaphragm, when made of aluminum, possesses many superior and desirable qualities, but it has been found that in actual practice it is liable to become buckled, thus materially lessening the fine qualities of the reproducer.

A further object, therefore, of the present invention is to provide means whereby the buckling of such diaphragm may be avoided and its fine qualities preserved.

In its preferred form, therefore, the invention consists of a metallic diaphragm, preferably of aluminum, having an axial opening of some considerable extent, preferably from three-eighths to one-half inch in diameter, surrounding which opening there is a plurality of annular corrugations on the central portion of the diaphragm with radial corrugations extending from the annular corrugations outward toward the periphery of the diaphragm. Secured over the axial opening is a cork disc which is much thicker than the diaphragm itself and of a diameter approximating that of the outer annular corrugation, the cork disc being secured to the diaphragm in any suitable way, as by cement. The end of the stylus bar opposite the stylus proper is connected preferably to the center of this cork disc, and the diaphragm is mounted in a suitable frame or box of metal between cork gaskets, the whole being held in place in any suitable manner, as by an elastic split ring, whose outer

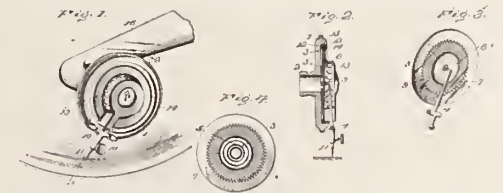

periphery enters an undercut groove in the walls of the diaphragm casing. If desired, the diaphragm may be, and preferably is, protected by a suitable shield or cover which likewise may be held in place by the split ring.

The inventive idea involved is capable of receiving a variety of mechanical expressions, one of which, for the purpose of illustrating the invention, is shown in the accompanying drawings, but it is to be expressly understood that such drawings are for the purpose of illustration only, and are not designed to define the limits of the invention, reference being had to the claims for this purpose.

In the drawings Fig. 1 is a perspective view of the reproducer mounted in position on the end of a suitable tone arm; Fig. 2 is a central sectional view on the line 2-2 of Fig. 1; Fig. 3 is a perspective view of the diaphragm, cork disc, and the stylus bar separated from the sound box or casing. Fig. 4 is a plan view of the diaphragm alone.

METHOD OF MAKING ACOUSTIC DIAPHRAGMS.—William W. Young, Agavam, Mass. Assignor by mesne assignments to Lucy A. Young. Patent No. 1,097,499.

This invention relates to improvements in methods of making acoustic diaphragms for talking machines, telephones and the like, and consists broadly and generally in roughening or indenting one or both surfaces or faces of a diaphragmal member and applying thereto a compound, emulsion, solution, or mixture which is capable of hardening and forming a coating and of permanently uniting with said member, as hereinafter set forth.

The object of the invention is to produce an acoustic diaphragm, of the class mentioned above, which possesses superlatively in addition to the ab-

solutely essential the otherwise desirable and long sought characteristics and qualities of a device of this kind, among which characteristics and qualities mention may be made here of durability and stability, resiliency and resonance, capability of giving out clear, loud and distinct tones of great volume and depth, and of evenly distributing the sound

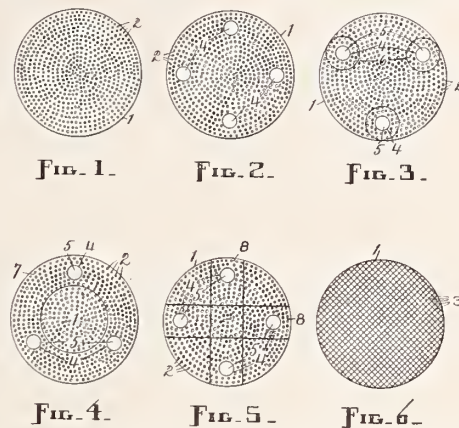

waves and immunity from blasts and scratching sounds and other alien and discordant noises.

Other objects will appear in the course of the following description.

A diaphragm constructed in accordance with the method broadly and generally outlined above may be improved for some and probably many purposes by perforating it and transforming the perforations or perforated parts into lesser diaphragms, or even by perforating and leaving the perforations open, as will be subsequently explained.

In the accompanying drawings, which form part of this application and in which like characters of reference indicate like parts throughout the several views, Fig. 1 is a face view of an imperforate diaphragm, and Fig. 2 a similar view of a perforated diaphragm, both made in accordance with this method; Figs. 3, 4 and 5 each a face view of a diaphragm including some form of the lesser-diaphragmal feature and made in accordance with said method, and Fig. 6 a face view of a diaphragm produced in the same manner as the others, except that it is checked instead of pitted.

ONE STYLE OF FIBRE NEEDLES.

The Victor Talking Machine Co. sent out last week the following letter announcing the discontinuance of one of the styles of its fibre needles:

"Our experience has shown us that it is unnecessary to market two styles of fibre needles. This seems to be the judgment of the trade also, as our sales have run mainly to the No. 1 size.

"We will, therefore, no longer supply the No. 2 Victor fibre needles, but will continue to furnish the No. 1 in envelopes of 100 and cartons of 250 at the established prices. All orders on file with us for the No. 2 will be canceled, and we suggest that you place your additional orders for the No. 1 needle accordingly."

An ounce of prevention may be worth a pound of cure, but it is just as well to be supplied with a little of both.

60 YEARS' EXPERIENCE

PATENTS

TRADE MARKS
DESIGNS
COPYRIGHTS & C.

Anyone sending a sketch and description may quickly ascertain our opinion free whether an invention is probably patentable. Communications strictly confidential. HANDBOOK on Patents sent free. Oldest agency for securing patents. Patents taken through Munn & Co. receive special notice, without charge, in the

Scientific American.

A handsomely illustrated weekly. Largest circulation of any scientific journal. Terms, \$3 a year; four months, \$1. Sold by all newdealers.

MUNN & Co. 361 Broadway, New York
Branch Office, 625 F St., Washington, D. C.

RECORD BULLETINS FOR JULY, 1914

VICTOR TALKING MACHINE CO.

No.	Title	Size.
17585	Sympathy—Waltz Hesitation, from "The Firefly" (Rudolph Friml).....Victor Military Band	10
	Swanee Ripples Rag—One-step (H. C. Thompson).....Victor Military Band	10
17588	Hesitation Waltz (F. Henri Klickmann).....Victor Military Band	10
	Who Paid the Rent for Rip Van Winkle Medley—One-step.....Victor Military Band	10
35374	Bayo Baya Maxixe (Dick Stone).....Castle House Orchestra, F. W. McKee, Dir.	12
	Creole Girl Maxixe (Vem Cá Mulata) (Francis Salabert). Castle House Orch., F.W. McKee, Dir.	12
	POPULAR BALLADS.	
17576	He's a Devil in His Own Home Town (Grant-Clark-Irving Berlin).....Billy Murray	10
	If They'd Only Moved Old Ireland Over Here (Blanche Ring's Hit in "When Claudia Smiles" (Kelly-Klein-Gillen).....Ada Jones	10
17587	When the Angelus is Ringing (Young Grant).....Lyric Quartet	10
	In the Valley of the Moon (Jeff Brannen).....Helen Clark-Henry Burr	10
17586	You Broke My Heart to Pass the Time Away (Leo Wood-Joe Goodwin).....Henry Burr	10
	That's a Real Moving Picture from Life (Sterling-H. Von Tilzer).....Billy Watkins	10
17589	If I Had Someone Like You at Home (I Wouldn't Want to Go Out) (McCarthy-Monaco).....Peerless Quartet	10
	Hands Off (Sterling-H. Van Tilzer). I. Kaufman	10
	MARCHES BY THE U. S. MARINE BAND.	
17577	National Emblem March (E. E. Bagley).....United States Marine Band	10
	German Fidelity March (Germanentreue) (H. L. Blankenburg).....United States Marine Band	10
	"GEMS" FROM RECENT MUSICAL PRODUCTIONS.	
35382	Gems from "High Jinks" (Hauerbach-Friml).....Victor Light Opera Co.	12
	Gems from "The Beauty Shop" (Pollock-Wolf-Gebest-Marks).....Victor Light Opera Co.	12
	PAUL ALTHOUSE SINGS FOR THE VICTOR.	
	Double-faced, Blue-Label.	
45055	Tosca—E lucevan le stelle (The Stars Were Shining) (Act III) (Puccini) In Italian.....Paul Althouse	10
	Pagliacci—Vesti la giubba (On with the Play) (Act I) (Leoncavallo) In Italian.....P. Althouse	10
	PURPLE LABEL RECORDS.	
60118	Oh Gustave! from "The Midnight Girl" (Das Mitternacht Maedel) (Paulton-Briquet-Philipp) Soprano and Baritone Duet.....Margaret Romaine and George MacFarlane	10
60119	The Castilian Maid (Thomas Moore-Liza Lehmann) Soprano Solo.....Margaret Romaine	10
60120	Look in Her Eyes. (Rourke-Kern) Baritone Solo. (Sung by Mr. MacFarlane with great success in "Miss Caprice").....George MacFarlane	10
	RED SEAL RECORDS.	
64442	Gioconda—Stella del marinar (Star of the Mariner) (Act II) (Ponchinelli) Mezzo-Soprano.. Margaret Ober	10
88491	La Bandoline—Rondeau (F. Couperin) Piano Solo.....Ignace Jan Paderewski	12
87193	Jewels of the Madonna—Serenata Raffaele (Raffaele's Serenade) (Act II) (Wolf-Ferrari) Baritone solo with Metropolitan Opera Chorus. In Italian.....Pasquale Amata	10
87182	Du, Du Liegst mir im Herzen (You Live in My Heart) (Folk Song). (Pax-arr. Wilhelm Berger) Soprano and Tenor Duet in German.....Alma Gluck and Paul Reimers	10
89078	Il Guarany—Sento una forza indomita (An Indomitable Force) (Antonio Gomez) Soprano and Tenor Duet. In Italian.....Emmy Destinn and Enrico Caruso	12
64414	All Through the Night (Old Welsh Air) Mezzo-Soprano in English.....Julia Culp	10
64434	A Dream (Poem by Chas. B. Cory, music by J. C. Bartlett) Tenor Solo in English.....John McCormack	10
87192	Ave Maria, adapted to the "Intermezzo" from "Cavalleria Rusticana" (Sacred words by F. E. Weatherly) (Mascagni) Tenor Solo, violin accomp. by Fritz Kreisler, violinist, and pianoforte by Vincent O'Brien—In English.....John McCormack	10
89079	Traviata—Dite alla giovine (Say to Thy Daughter) (Act II, Scene I) (Verdi) Soprano and Baritone Duet, In Italian.....Frieda Hempel and Pasquale Amato	12

COLUMBIA GRAPHOPHONE CO.

SYMPHONY DISC RECORDS.		
A5564	The Moon Has Raised Her Lamp Above (Benedict). Tenor and Baritone Duet in English with orch.....Morgan Kingstom & Louis Kreidler	12
	The Last Watch (Pinsuti). Tenor Solo, in English with orch.....Morgan Kingstom	12
36888	Will Ye No Come Back Again? (Nairne) Soprano Solo in English, with orch.....Margaret Woodrow Wilson	12
A5558	I Puritani (Bellini) "Suoni la tromba" (Sound the Trumpet). Baritone and Bass Duet, in Italian, with orch.....H. Dufranne and H. Scott Thais (Massenet) "Voila donc la terrible cite" (Behold the terrible city). Baritone Solo in French with orch.....Hector Dufranne	12
E1552	Prelude to the Deluge (Saint-Saens) Violin Solo Arthur Gramm	10
	Spanish Dance (Rehfeld). Violin Solo. A. Gramm	10
	Felix Weingartner, Conductor.	
A5559	Carmen (Bizet). Overture and Intermezzo.....Columbia Symphony Orchestra	12
	L'Arlesienne Suite (Bizet). Prelude and Adagio.....Columbia Symphony Orchestra	12
	DOUBLE DISC RECORDS.	
A1537	Southern Zephyrs (Levy).....Prince's Orchestra	10
	Warbler's Farewell (Tobani). Violin, Flute, and Harp..George Stehl, Marshall P. Lufsky and Charles Schuetze	10
A1527	Summer (Chaminade). Boy-Soprano, orch. accomp.....Walter Lawrence	10
	A Spring Morning (A Pastoral) (Carey) Boy-Soprano, orch accomp.....Walter Lawrence	10
A1528	Through the Panama Canal (Von der Mahden) Prince's Band	10
	From Ocean to Ocean (Smith). Prince's Band	10
A1529	Catch Me If You Can (Noel). Concertina.....Alexander Prince	10
	Pride of the Roses (Lavalle). Accordoon.....Pietro Deiro	10
A1530	Years Ago (Devonne). Tenor Solo, orch. accomp.....Harry McClaskey	10
	Can't You Hear Me Callin'? (Caro Roma). Counter-tenor, orch. accomp.....Frank Coombs	10

A5560	Medley of Old Songs—One-step (Arr. by M. Smith).....Prince's Band	12
	Kitty Mackay (Platzan). Hesitation-Waltz.....Prince's Band	12
A5561	Joan Sawyer Maxixe (Stagliano). Prince's Band	12
	All Aboard for Dixie Land—One-step. (Cobb) Prince's Band	12
A5562	The Castle Walk (Europe and Dabney).....Prince's Band	12
	Castle's Half and Half (Europe and Dabney).....Prince's Band	12
A5563	Esmeralda (Castle Innovation Waltz) (De Mesquita).....Prince's Band	12
	Pepper Pot (Ivers)—One-step.....Prince's Band	12
	SONG HITS FOR JULY.	
A1532	Who Paid the Rent for Mrs. Rip Van Winkle? (Bryan and Fischer). Tenor Solo, orch. accomp.....Billy Watkins	10
	Follow Up the Big Brass Band (Reed). Orch. Peerless Quartet	10
A1535	He'd Push it Along (Abrahams). Baritone Solo, orch. accomp.....William Halley	10
	They Don't Hesitate Any More (Puck) Baritone Solo, orch. accomp.....William Halley	10
A1536	Harmony Bay (Sherman). Orch. accomp.....Peerless Quartet	10
	On the Island of Pines (Carroll). First and Second Tenor Duet, orch. accomp.....Albert Campbell and Henry Burr	10
A1533	When the Angelus is Ringing (Young and Grant). Orch. accomp.....Peerless Quartet	10
	In the Valley of the Moon (Brannen). Soprano and Tenor Duet, orch. accomp.....Helen Clark and Henry Burr	10
A1534	Me and Mandy Lee (Mills). Baritone and Tenor Duet, orch. accomp.....Arthur Collins and Byron G. Harlan	10
	When They Christened Brother Johnson's Child (Tracy and Jentes). Orch. accomp.....Peerless Quartet	10
A1531	If I Were the Ocean and You Were the Shore. (Bryan and Wells). Tenor Solo, orch. accomp.....Henry Burr	10
	Just a Little Bit of Green (Brauen and Lange). Baritone Solo, orch. accomp.....John E. Meyer	10

THOMAS A. EDISON, INC.

BLUE AMBEROL REGULAR.		
2325	Fourth of July Patrol, with Chorus.....New York Military Band	
2326	Fourth of July at Punkin Center (Stewart). Talking.....Cal Stewart	
2327	Favorite Airs from "Ernani" (Giuseppe Verdi) orch accomp.....Edison Light Opera Co.	
2328	I Love the Ladies (Jean Schwartz). Tenor, with orch accomp.....Irving Kaufman	
2329	Gippsland March (Alex. F. Lithgow).....New York Military Band	
2330	Love's Hesitation—The Beauty Shop (Chas J. Gebest) Soprano and Baritone, orch accomp.....Elizabeth Spencer and Vernon Archibald	
2331	Sing Rock-a-bye Baby to Me (Webb Long) Counter-tenor, orch. accomp.....Will Oakland	
2332	On the Banks of Lovelight Bay (W. R. Williams) Contralto and Tenor, orch. accomp.....Helen Clark and Emory B. Randolph	
2333	Off with the Old Love, On with the New (Harry Carroll). Tenor, orch. accomp.....Walter Van Brunt	
2334	Hesitate Me Around, Bill (Malvin Franklin). Comic auct, orch. accomp.....Arthur Collins and Byron G. Harlan	
2335	He's Working in the Movies Now (Henry Lodge) Comic song, orch. accomp.....Billy Murray	
2336	In the Heart of the City that Has No Heart (Joseph M. Daly) Contralto and tenor, orch. accomp.....Ada Jones and Irving Gillette	
2337	The Wedding of the Rose—Intermezzo (Leon Jessel).....American Standard Orchestra	
2338	Norah McNamara (Fiske O'Hara) Tenor, orch. accomp.....Eugene Emmett	
2339	(a) Traümerci (Schumann); (b) Romance (Schumann). Violin.....Elias Breeskin	
2340	Sans Souci—Maxixe Bresilienne (A. N. Green). For dancing.....National Promenade Band	
2341	A Farewell (Samuel Liddle). Tenor and chorus. Emory B. Randolph and Chorus	
2342	Believe Me If All Those Endearing Young Charms (Thomas Moore). Harp-Zither.Kitty Berger	
2343	Passing of Salome—Waltz Hesitation (Archibald Joyce). For dancing.....National Promenade Band	
2344	On the Shores of Italy (Jack Glogau). Tenor duet, orch. accomp.....A. H. Campbell & I. Gillette	
2345	Dream Girl o' Mine—Chauncey Olcott's "Shameen Dhu" (Cass Freeborn). Tenor, orch. accomp.....Reed Miller	
2346	He'd Have to Get Under—Get Out and Get Under Medley—Turkey Trot. For dancing.....National Promenade Band	
2347	Chicken Reel (Jos. M. Daly). Coon song, orch. accomp.....Edward Meeker	
2348	Pepper Pot One-step (Harold Ivers). For dancing. National Promenade Band	
	SIX BLUE AMBEROL RECORDS	
	By Homer Rodeheaver	
	Records with organ accompaniment of six of the best known revival hymns sung at "Billy" Sunday's meetings. Mr. Rodeheaver is musical director of the evangelistic meetings of Mr. Sunday, and is soloist as well.	
2349	If Your Heart Keeps Right (B. D. Ackley).....	
2350	I Walk With the King (B. D. Ackley).....	
2351	Mother's Prayers Have Followed Me (B. D. Ackley).....	
2352	My Father Watches Over Me (Chas. H. Gaeriel).....	
2353	Old Fashioned Faith (B. D. Ackley).....	
2354	Somebody Cares (Homer Rodeheaver).....	

WHY OWN WEBSTER'S NEW INTERNATIONAL DICTIONARY

THE MERRIAM WEBSTER?

BECAUSE it is the only new unabridged dictionary in many years. BECAUSE it defines over 400,000 Words. 2700 Pages. 6000 Illustrations. BECAUSE it is the only dictionary with the new divided page. BECAUSE he who knows Wins Success. Let us tell you about this new work. WRITE for specimens of the new divided page, full particulars, etc.

G. & C. MERRIAM CO., Springfield, Mass.

Mention this paper, receive FREE, set of Pocket Maps

NEW YORK'S NEW TRADE MARK.

Merchants' Association of New York Announces Prize Award for Suitable City Emblem to Be Used by All Shippers—Many Designs Submitted in Contest—Other Cities Have Emblems—A Handsome Design.

New York now has her own trade-mark, designed so that the products of Gotham that find their way throughout the world may carry an advertisement of the city and thus emphasize the commercial importance. The new city emblem was evolved by the Merchants' Association after a prize competition in which a large number of drawings were submitted. It is a circular design, showing a three-quarter view of the Statue of Liberty upon its pedestal, thrown into relief against a background displaying the harbor and shipping and a typical portion of the skyline of lower Manhattan, with the name "New York" above. The design lends itself admirably to reproduction either in colors, in half-tone, in line drawing, or as a stencil.



COPYRIGHT, 1914 THE MERCHANTS' ASSOCIATION OF NEW YORK

The emblem was announced at the dinner given by the members' council of the Merchants' Association for the sons of members at the Waldorf-Astoria on Tuesday of this week.

The competition which resulted in the production of the emblem was inaugurated by the Merchants' Association several months ago. Its terms provided for a prize of \$150 for the most meritorious design, and a second prize of \$50 for the design which was judged to be next in merit.

The first prize was won by David B. Hills, of Brooklyn. Mr. Hills is a student in the Art Students' League of New York, and is employed by the Iron Age. He has won several other competitions.

The second prize was awarded to Raphael Beck, of Buffalo, an artist who holds prizes awarded to him at several expositions.

When the contest closed 248 designs had been submitted from all over the country. The designs offered a great variety of treatment and of artistic merit, some of them being only rough sketches to serve as suggestions, while others were elaborately worked out.

In making the award it was necessary to take into consideration the adaptability of each design for reproduction as a stencil, as well as for printing in black and white or in colors. This eliminated many meritorious designs which were too elaborate for reproduction to stencil form.

It is the intention of the association that merchants and manufacturers who ship goods from New York to all parts of the country shall attach to each package shipped a reproduction of the design in the form of a paster, stencil, tag, or in any other form that the shipper may prefer. In this manner the immense volume of merchandise which goes out annually from this city will advertise New York's supremacy as a commercial center all over the world.

The design has been copyrighted by the Merchants' Association as a precautionary measure. Permission to use it will gladly be given to merchants, manufacturers and others upon application to the association.

Most other cities already have commercial emblems which are used for advertising purposes, but no such emblem has heretofore been adopted by New York.

\$ \$ \$ \$ \$ \$ \$ \$ \$

\$ \$ \$

\$ \$ \$

\$ \$ \$

\$ \$ \$

\$ \$ \$

READE your trade paper! Get The Talking Machine World regularly—It is worth many times to you its annual cost.

There is but one talking machine paper covering this entire industry, and it is admitted by all that it is of great aid to the dealers in every part of this country.

New economic conditions make certain knowledge necessary on the part of merchants, and in every issue of The World there is contained educational matter, instructive service, business news and technical articles which are worth many times the cost of the paper.

Thousands have been benefited by the business articles which appear in The World, and every talking machine dealer should receive it regularly.

The only way to do that is to pay for it, and the cost is trifling—a little over eight cents a month, and for that small sum The World, with all its mine of information, is at your service.

If you do not receive the paper regularly, just put your dollar in an envelope and address it to the office of the publication, and you will say that it is the best investment that you have ever made.

Do not delay but send on your dollar now.

Recollect that your competitor is getting The World—getting it regularly, and in it he is securing some valuable pointers—information which places you at a disadvantage if you do not read the paper.

Do not overlook such a valuable contributing factor to your business success.

EDWARD LYMAN BILL
PUBLISHER

373 Fourth Avenue,

New York City



The Sales Arguments for Edison Phonographs

were built into them by the inventor whose name they bear.

As he incorporated each detail in the finished instrument, adding some improvement here, some refinement there, he was unconsciously creating the greatest arguments that a merchant ever found at his disposal.

Are you one of those merchants who sees the wisdom of handling the kind of merchandise that speaks for itself?

Thomas A Edison

INCORPORATED

59 Lakeside Ave., ORANGE, N. J.



The TALKING MACHINE WORLD

AND
NOVELTY
NEWS

Published Each Month by Edward Lyman Bill at 373 Fourth Avenue, New York, July 15, 1914



The best-known trade mark in the world

"The Victor talking machine's design, 'His Master's Voice,' has become a household word, and the quaint little fox terrier at attention before the horn is familiar to more Americans than any of the world's great masterpieces"—*Collier's Weekly*.

The Pathéscope and Motion Pictures

Were the Great Features of the Jobbers' Convention at Atlantic City

The Pathéscope was Demonstrated and Universally Endorsed as

The Companion Entertainer to the Talking Machine

Pathéscope Motion Pictures taken of the jobbers at the Chalfonte, on the Boardwalk, and Tangoing on the Beach, can be seen at the Pathéscope Salon, Aeolian Hall. Copies of this film furnished gratuitously to Pathéscope dealers requesting them.



Phonographs and Pathéscopes Combine Music and Movies

A heart to heart Talk with the Dealer in Talking Machines.

Wherein is suggested an opportunity for making two sales grow where only one grew before



YOU, as a Dealer in Talking-Machines, have helped to bring to the homes of an enormous public the opportunity of enjoying all kinds of music, ranging from the vaudeville parody to grand opera scores of the world's greatest composers.

The Motion Picture has made it possible for this same public to enjoy all kinds of acting, from poor comedy to the master-pieces of the world's greatest dramatists, but heretofore only in the Theatre.

Probably you have felt the competition of the Motion Picture Show as a rival Entertainment to the Talking Machine.

Instead of buying new machines or more records, thousands of people, with money to spend for Entertainment or Amusement, are yielding to the fascination of the Motion Picture.

Instead of losing business by the competition of Music and Movies, why not increase your business by their combination?

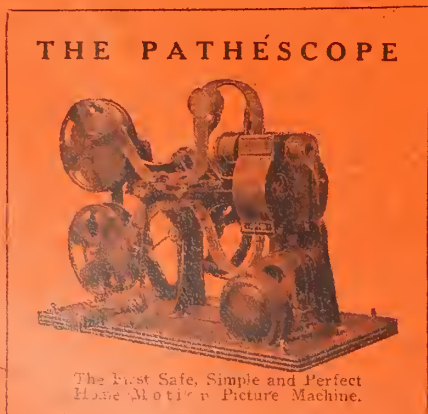

The First Safe, Simple and Perfect Home Motion Picture Machine.

THE PATHÉSCOPE

YOU CAN!!

The Talking-Machine and the Motion Picture Machine should go together and give the owner of both the fullest measure of Entertainment and Amusement.

You, as a Talking-Machine Dealer, are the logical distributor

of the Home Motion Picture Machine. In Europe, where the Art of Cinematography is far more advanced than in this country, the great firm of **Pathé Frères** (Capital 30,000,000 Francs), has been working for years perfecting the *Pathéscope*.

In its simplest form it requires no electric connections whatever. The simple act of turning the handle actuates the film, generates its own (incandescent) electric light and protects the picture in **living, fascinating motion on the screen.**

Other models take current from an ordinary electric light socket, project a larger picture, and require no cranking.

These instruments are a marvel of mechanical construction, combining a beauty of finish with a perfection of operation that create the greatest enthusiasm and delighted amazement wherever shown.

The use of a special, narrow-width, **non-inflammable film** insures absolute safety, without fire risk, or insurance restrictions. In this respect the *Pathéscope* stands unique and alone. The only instrument and film **approved by the National Board of Fire Underwriters.**

The owner of a *Pathéscope* may exchange his Reels as often as desired by the payment of a small fee to the *Pathéscope* Film Exchanges.

Progressive Dealers can readily see that a new field of profitable opportunity awaits development.

Every customer who has bought a good Talking-Machine, or Player-Piano, is a prospective purchaser of a *Pathéscope* in addition.

You don't have to develop new clients constantly as you do in your sale of Musical Instruments. You can commercialize the good will of your old customers and increase their appreciation by selling them a *Pathéscope*. Double your volume of business and, without a corresponding increase in your rent, or overhead expenses, **you may triple or quadruple your net profits.**

Why not investigate the profitable possibilities in owning a local Film Exchange?

For Demonstrations or Catalogue address:

Announcement

The Wanamaker Stores in New York have been appointed Retail Distributors for the *Pathéscope*, where it is displayed and demonstrated in the appropriate environment of their magnificent Talking Machine Department.

PATHÉSCOPE

Department 4

AEOLIAN HALL, NEW YORK

Agencies:

515 Crozer Bldg., PHILADELPHIA
1306 Marquette Bldg., CHICAGO

622 Kittredge Bldg., DENVER
613 1/2 Second Ave., SEATTLE

Responsible Representation desired elsewhere

The Talking Machine World

Vol. 10. No. 7.

New York, July 15, 1914.

Price Ten Cents

BIG COLUMBIA DEPARTMENT.

Western Fancy Dry Goods Co., Sole Distributors for Columbia Products in Large Section of Western Canada, Opens Separate Quarters for Department Under Management of Robert Shaw Assisted by Competent Staff.

(Special to The Talking Machine World.)

WINNIPEG, MAN., July 3.—The Western Fancy Dry Goods Co., sole distributor for the Columbia Graphophone Co. for the provinces of Manitoba, Saskatchewan, Alberta and British Columbia, has made special preparations to take care of the rapid increase in the business in that department, which has been located in special quarters in the Gowans Kent building, this city, and placed under the direct management of Robert Shaw. Mr. Shaw is an aggressive and thoroughly experienced talking machine man and a Columbia enthusiast, and is well known to the trade in the States owing to his having attended several of the conventions of the National Association of Talking Machine Jobbers.

Mr. Shaw has brought together an increased staff of assistants and has started a live campaign in favor of the Columbia line among the trade in Western Canada, and in which strong letters and bulletins are proving big factors.

VICTOR MUSIC, FOR DANCING. A HIT.

Exhibition of Dances to Victor Music in Store of Southern California Music Co. Attracts Large and Enthusiastic Crowd.

(Special to The Talking Machine World.)

LOS ANGELES, CAL., July 4.—Demonstrating the practicability of the modern talking machine as a desirable instrument for furnishing the latest dance music, more than 300 visitors yesterday enjoyed the exhibition given by Miss Norma Gould, assisted by Erwin Volze, at the store of the Southern California Music Co. and declared it an unqualified success.

The initial exhibition proved so popular that the company has decided to give instructions and demonstrations each Tuesday and Friday from 2 until 4 o'clock, and invites the public to participate.

WILLSON INTERVIEW FEATURED.

The greatly increased demand for talking machines and records due to the present dancing craze formed the subject of a lengthy and interesting article which appeared in the New York Tribune of June 21. A reporter for that paper visited the headquarters of the Columbia Graphophone Co., and in a chat with H. L. Willson, assistant general manager, he referred to the development of the business and its varied aspects in a most comprehensive way. The interview was most readable and informing to that section of the general public which has not kept in touch with the remarkable growth of the business of the Columbia Graphophone Co. and the expansion of the talking machine business generally.

GLOBE TROTTER GRAHAM.

A line from Jake Graham, the globe trotter, from Melbourne, Australia, says, according to his version, the dealers in Auckland, New Zealand, and in Melbourne lack the progressiveness of the American and English dealers. Mr. Graham sends kindly remembrances to all of his American friends.

VICTROLA WITH THE ORGAN.

Charles H. Demorest gave a novel program on the organ in Tally's Broadway Theater in Los Angeles, recently in which the Victrola was used with organ accompaniment in Leoncavallo's arioso from "I Pagliacci," sung by Caruso, and in John McCormack's singing of Marshall's "I Hear You Calling Me."

SELECTING THE CHORUS GIRL.

Using the Phonograph for Tests of Voice—How the Record Is Replacing the Army of Stage Struck Girls in Managers' Offices.

There will be a visible decrease in the size of the army of stage struck girls who invade Broadway this summer.

R. H. Burnside and Bruce Edwards, Charles Dillingham executives, are busy listening to a phonograph in the Globe Theater these days. They are picking chorus girls from records which have been sent to them.

In order to get a wider selection than heretofore, Mr. Dillingham recently announced that any girl



How the Artist Pictures Present Conditions.

who was ambitious or crazy to go on the stage could go to the nearest phonograph store, make a record of her voice, and send it, together with her photograph to his office.

"We have discovered three remarkable voices possessed by beautiful girls, if the photographs submitted are their own," said Mr. Burnside recently. "We have sent for these young women, and if they are what we think they are, they will be members of one of our companies next fall. From the number of records and photographs which we are receiving, I believe we can announce a canned peach chorus for next season."

E. BLOUT ENLARGES QUARTERS.

Prominent Victor Distributer and Dealer Installs Series of Demonstration Booths in Store Adjoining Present Quarters—Handles High Class of Trade in His Territory.

Emanuel Blout, the prominent Victor distributor of 2799 Broadway, New York, who does a large and growing retail business in the exclusive residence section in which he is located, has found it necessary to secure the store immediately south of his present quarters on Broadway for the housing of additional demonstration booths to the number of five, making twelve booths in all now in service. The booths are enclosed in plate glass, and the wood work is finished in a rich shade of light gray with just enough decoration to make it attractive.

Mr. Blout enjoys a strong demand for the higher priced types of Victrolas and the records of the Red Seal quality from his retail customers. The record racks in the basement have also been increased in number and the facilities for handling both machines and records greatly improved. An automobile delivery service, with uniformed attendants is also an attractive and convenient feature of the Blout system. A storage warehouse in 110th street takes care of reserve and surplus stocks of machines and records.

It is well to remember that a fifteen-foot diameter balloon holding hundreds of thousands of cubic feet of gas can be punctured by a ten-cent pocketknife.

TO HEAR OPERA STARS IN ADVANCE.

Patrons of Grand Opera in Baltimore to Listen to Records Made by New Opera Singers Before the Season Opens in that City.

(Special to The Talking Machine World.)

BALTIMORE, MD., July 3.—At a conference between Bernard Ulrich, general manager of the Chicago Grand Opera Co., and Wilbur F. Kinsey, manager of the Lyric, last week, it was tentatively agreed that early in the fall the patrons of the grand opera will be invited to the assembly hall of the Lyric to hear the new opera stars, who will appear here this coming winter, on the phonograph.

The records have never been played in America, and both men think that the plan is a good one.

MUSIC MAKES BETTER RACE HORSES

Particularly Ragtime Soothes Equine Nerves, Says Trainer Who Uses Talking Machine.

(Special to The Talking Machine World.)

CINCINNATI, O., July 3.—Bill Perkins, noted horse trainer, is a believer in music to soothe nervous racers.

Perkins is at the Latonia race course, and has installed a talking machine in his stable. The stable hands have been working it overtime. The trainer says there is nothing like music to quiet a nervous horse just before it goes to the post or returns from a race. He says the animals prefer ragtime.

Perkins thinks he has solved a great problem. Nervousness is characteristic of the thoroughbred, something trainers have been unable to cure. Perkins believes his idea in soothing strained nerves with music may mean an evolution of training methods. Already his innovation is working wonders, he says.

DEATH OF ADEMOR M. PETIT.

(Special to The Talking Machine World.)

WEST ORANGE, N. J., July 2.—The friends of Ademor M. Petit will be sorry to learn of his sudden death, which occurred in this town last week. Mr. Petit at one time worked in the laboratory of Thomas A. Edison, Inc., and later conducted a business in Baltimore. During the past few years he was not connected with any concern and carried on experimental work for the manufacture of talking machines. He had invented parts of some of these machines. His inability to sell a few recent inventions, among them a process for manufacturing chewing gum, resulted in periods of melancholia.

The deceased was born in Canada some forty-eight years ago, and had made his home for about twenty years in West Orange. Besides his widow and daughter he is survived by two brothers and a sister.

BUY BUILDING IN MERIDIAN.

(Special to The Talking Machine World.)

MERIDIAN, MISS., July 3.—The A. Gressert Music House, which handles the Victor and Edison lines of machines and records in this territory with great success, has just secured what is known as the Wagner property, adjoining the Citizens' Bank building, this city, and at the expiration of present leases will remodel and occupy the entire building. The consideration was \$21,000. The Gressert Music House owns the property on Fifth street it occupies at present, and which it will occupy until the new store is ready.

SUCCESSFUL SELLING FORCE.

Says a merchant of wide experience: The successful selling forces of to-day are made up of men who can think and who do think, and men who can be relied upon to do the right things at the right time; men who are always capable of taking advantage of any situation that may arise.

The Nation's Wisest Heads

Selected

RICHMOND, VIRGINIA

As the Fifth Regional Bank City

Make the South's largest Victor Distributors your Supply House for

VICTORS VICTROLAS RECORDS and SUPPLIES

A glance at the map will convince you of our advantageous location for

Quick Shipments Low Freight Rates Early Deliveries

In addition we offer SERVICE OF THE HIGHEST ORDER—LARGEST STOCK TO CHOOSE FROM—UNLIMITED DEALER CO-OPERATION.

Place Your Orders Where Service and Satisfaction Go Hand-in-Hand

It means a time and money saving—it means a better, more efficient handling of Rush Orders—it means just what you want, when you want it. Get busy—test us.



Complete
Stock
of
Foreign
Records

The Corley Company

The South's Largest Victor Distributors

RICHMOND, VIRGINIA



SUBSTANTIAL GAINS THE FIRST HALF OF THE YEAR

Reported by the Talking Machine Trade of San Francisco—General Outlook Most Pleasing—Eilers Planning Expansion—Sherman, Clay in Spokane—Columbia Co. to Make Records of Best Exposition Song—Interesting Budget of News from the Pacific Coast.

(Special to The Talking Machine World.)

SAN FRANCISCO, CAL., July 3.—Talking machine interests in this city are fairly well pleased with the outcome of the first half of the year's business. In some instances the gains were hardly so large as were anticipated at the first of the year, but few complaints are being registered, as it is generally conceded by both wholesalers and retailers that talking machines have held their own better so far this year than most other lines of business, and now things seem to be taking a turn for the better all around, so no uneasiness is felt regarding the prospects for fall. Country trade is already showing the effects of the harvesting of bountiful crops, and activity is being resumed in all the principal underlying industries of this section. One effect of the rather quiet spring is that business men generally are conducting more active campaigns for summer trade than in former years. Heretofore summer dullness has been accepted as inevitable and dealers in most lines of business, including music houses, have relinquished their efforts noticeably during the vacation period, but this year various ways and means are being tried out to stimulate business during what is normally the quietest period of the year. In the talking machine quarters the extra exertion is making itself felt, as no falling off in sales of either records or machines has been noted the past month. Additions and improvements of talking machine departments continue in order along the coast. The past month two more firms have inaugurated extensive alterations at certain stores, which will give talking machines considerable more prominence.

Larger Department for Eilers.

Eilers Music House in this city, which has given but little attention to talking machines in the past, is installing a well equipped department, and is preparing to carry a large stock, including Victor, Columbia and Edison products. The new department is being fitted up on the main floor of the establishment, where four large soundproof demonstration rooms are provided, besides general display space. Additional space is also available on the floor above. H. P. Rothermel has been named manager of the department. He is well known to the Coast trade, and particularly in San Francisco, as this was his home until a few years ago, when he became identified with Eilers Music House in Portland. He expects to have his stock sufficiently complete to make a compre-

hensive showing by time the department is ready for use, which will be in about two weeks.

Modernizing Stores Everywhere.

(Sherman, Clay & Co., Coast distributors of Victor products, who have spent large sums of money in the last few years modernizing their stores in various Coast cities, with the result that they have a chain of stores which would do credit to any section of the country, are this summer making extensive improvements in their Spokane establishment. Heretofore they have occupied only one floor of the building in which they are located there, but in the future they will have the entire four-story and basement. The plans for the alterations in the structure amount practically to its rebuilding, and necessitates the removal of the business to temporary quarters while the work is in progress. All departments will benefit by the enlargement of the store and none more than the talking machine section. The retail department will be located on the ground floor, and quarters will be fitted up in the basement for the wholesale department. F. W. Stephenson, secretary of the company, visited the firm's interests in the Northwest the past month, and reports conditions improving in that section.

Substantial Gain for Wiley B. Allen Co.

J. J. Black, manager of the Wiley B. Allen department, reports sales for June showing a substantial gain over the corresponding period of last year. The demand for the smaller machines for vacation use was a feature of the month's business, but interest was not confined to the smaller outfits by any means. The new models X and XI Victrolas especially in fumed oak attracted very favorable attention. Clarence Anrys of the sales-force returned from the East recently after an enjoyable trip to the markets with his father, Frank Anrys, manager of the Allen Co. They combined business and pleasure, attending the national piano convention at New York, and visiting various factories with which the company does business. F. P. Corcoran and C. E. Edwards spent their June vacations in the Santa Cruz mountain district.

Visitors to Columbia Co.

The local headquarters of the Columbia Graphophone Co. were visited the past month by W. E. Henry, manager of the company's interests in Pittsburgh, and also by Chas. A. Prince, musical director of the Columbia Co. The latter is a native of San Francisco, and was visiting his

parents and renewing acquaintances in this city.

Records of Best Exposition Song.

An announcement published recently in one of the local daily papers has already brought many inquiries to the office of the Columbia Graphophone Co. It stated that the paper had arranged with the Columbia Graphophone Co., through the Pacific Coast manager, W. S. Gray, for the production and wide circulation of records containing the best exposition song composed by a California writer, the details of the contest to be announced later. Mr. Gray says there will be a substantial prize for the winner of the contest, and he thinks such a composition would do much to boost the Golden State and the exposition. In a telegram to Mr. Gray, Geo. W. Lyle, general manager of the Columbia Co., said: "Assure the Bulletin that our confidence in the musical ability of California authors is such that we pledge ourselves to make records of and widely advertise prize-winning song obtained through its contest."

Personals and Visitors.

C. P. LeRoy, traveling ambassador of this office of the Columbia Graphophone Co., was married here recently, and is now away on his honeymoon. Wholesale Manager F. R. Anglemeier says country business is keeping up in splendid shape, and he attributes much of the increasing interest in talking machines to the dance records, which he says are in demand everywhere.

Mr. Ridgeway, representing Lyon & Healy, Chicago, was a recent visitor to the Coast trade.

J. E. McCracken, representing the Pacific Phonograph Co., jobbers of Edison products, called on the trade in southern California the past month, and A. R. Pommer, head of the business, says he was successful in lining up several new accounts in that section.

HUSTLING BALTIMORE HOUSE.

Cohen & Hughes Have Developed a Thriving Jobbing Trade.

(Special to The Talking Machine World.)

BALTIMORE, MD., July 7.—Cohen & Hughes, the well-known Victor distributors, are splendidly located in this city, where they have superb facilities to take care of the jobbing trade. This firm is conceded to be one of the most progressive in this part of the country, and the talking machine dealers in Baltimore and contributory territory have found that their service is excellent. They carry a large stock of Victor talking machines, records and accessories of all kinds and make a specialty of filling orders with promptness.

In Baltimore this company stands admittedly high in business circles, and its enterprise has always been conducted along consistent and progressive lines.

The Success of Your Talking Machine Department

Is to a *large* extent dependent upon the service your distributor gives you.
This admitted makes it important that you secure the best service obtainable.

AND THAT IS EASTERN SERVICE

To use it is to swear *By* it not *At* it.
May we not have the opportunity to convince you that our service is exceptional?

EASTERN TALKING MACHINE COMPANY

177 TREMONT STREET, BOSTON, MASS.

EDISON

FOR NINETEEN YEARS TALKING MACHINES EXCLUSIVELY

VICTOR

OUR DISC RECORD ALBUMS

ARE THE BEST FOR VICTOR, COLUMBIA
AND ALL OTHER TALKING MACHINES

THE ONLY CONVENIENT AND SAFE WAY TO PROTECT DISC RECORDS

These Record Albums will Pay for Themselves in a Short Time by Preserving Records. When Full the Albums are Flat and Even Like Books. They will Fit in a Library Cabinet or Book Case, or They will Lie Flat on One Another.

For Durability, Artistic Design and Finish, our Albums have no equal. They are made in the most substantial manner by skilled workman, and are first-class in every particular. We sell them at very low prices to meet competition.

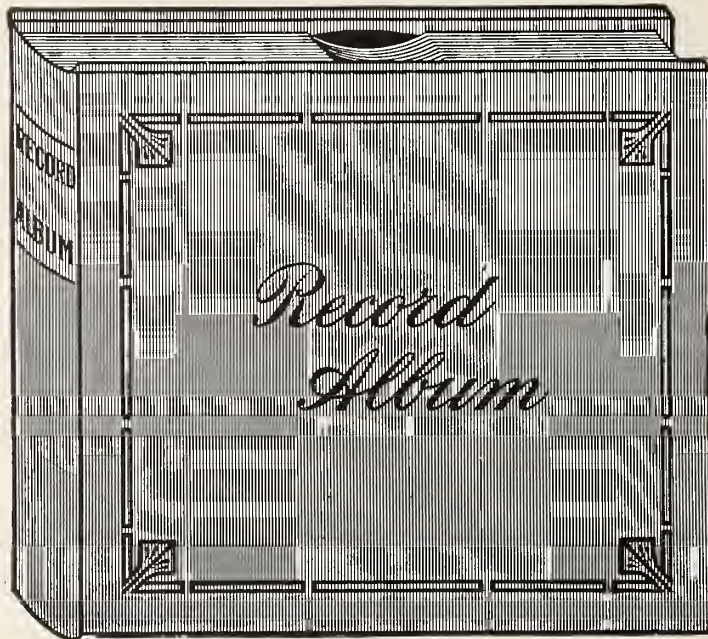

TO DEALERS:

In reply to the many requests we are now receiving for RECORD ALBUMS containing 10 pockets, we have to say we make Albums, containing any number of pockets that are wanted and to fit all styles of Cabinets.

Write for sample and prices of our Albums, which are superior to all others

Address NATIONAL PUBLISHING CO., 235 South American St., Philadelphia, Pa.

NEW DEPARTMENT FOR ATLANTA.

Chamberlain-Johnson-DuBose Co. Opens New Parlors with Three Complete Lines of Products—T. F. DeLaney in Charge.

(Special to The Talking Machine World.)

ATLANTA, GA., July 8.—This month witnesses another entry into the hustling company of local talking machine dealers.

The Chamberlain-Johnson-DuBose Co., one of the oldest, largest and best-known department stores in the South has entered the talking machine game with the same thorough method that characterizes its business in other departments.

The firm has built five beautiful and commodious demonstration booths at the entrance to its furniture department on the first floor and have stocked a full line of Columbia, Victor and Sonora machines and records.

The new department is in charge of Thomas F. DeLaney, formerly with the Columbia Chambers street headquarters, and later manager of the talking machine department of Otto Wissner, Inc. Mr. DeLaney is a man of broad experience and sterling ability, and on this account, as well as by reason of his genial personality, is making friends and good business for his new connection.

Yes, it has been hot; no question about that, but not too hot for porch dances nor too hot for the enterprising talking machine dealer to make full capital of the public's amiable weakness in that direction.

Every one of Atlanta's six most select clubs has its talking machine and a full supply of dance records, and there is hardly a moment from sundown to midnight when they are not playing for some dancing party, large or small. This, of course, breeds an endless number of prospects for the dealer, and the various departments are showing almost mid-winter activity.

It is just as hard for a man to mend his ways as for a woman to patch up a quarrel.

IMMORAL RECORDS IN GERMANY.

Strong Effort Being Made to Stamp Out Evil in That Country—Record Censors Suggested as Solution of Difficulty.

The German trade press has lately devoted quite an amount of space to the immoral record question, which is evidently much more acute on the Continent than in this country. One of the subjects of legislation in the next Parliamentary session has reference to the suppression of immoral literature, and it is expected that records will be brought within this category. In view of this prospect the German trade has before it a suggestion to institute a voluntary censure committee, whose duty would be to adjudicate upon any new records the character of which might be called into question. There is some sort of law in existence, but it is not regarded as strong enough to meet the case. Although the confiscation of "questionable" records is not infrequent, they are still issued, doubtless unwittingly, having regard to the liberal temperament of the people. The trade now desires to avoid giving offense even to the most puritanical sect, and the best means to this end is the proper organization of a committee of representative men as record censors. The Phonographische Zeitschrift avers that the expenses of such a committee would be more than counterbalanced by the saving of the substantial costs involved by the confiscation of indecent records. It is on this very point, however, that the proposal hangs fire, for although many manufacturers recognize the advantage of it, they fear the cost of administration. But for protection's sake the gramophone trade is urged to solve the problem in the way suggested.

Judge Hand in the United States District Court last week confirmed a composition of Edwin F. Skinner, trading as the Schafford Album Co., 27 Walker street, New York, with creditors at twenty cents on the dollar.

BELIEVES IN WINDOW VALUE.

How the Wallace Co., of Pittsfield, Mass., Features the Columbia Line Which It Handles—Notable Artists Introduced.

The Wallace Co., of Pittsfield, Mass., which recently arranged to handle the products of the Columbia Graphophone Co., certainly has the correct idea of the value of attractive window displays, as the accompanying illustration evidences. The win-



Window Display of Wallace Co., Pittsfield.

dow shown herewith was the first display used by the company to feature its Columbia agency, and the excellent results achieved by the display have encouraged the Wallace Co. to plan other original and artistic windows for use throughout the year.

The featuring of various Columbia artists in this window display was one of the factors that contributed to the success of the window, as the personal element invariably attracts attention from passers-by, and particularly when the products are displayed for the first time in new quarters. The pleasing arrangement of the machines and records in this display is well worth commendation and notice.

Don't judge by appearances. The fellow who indulges in hot air usually lacks steam.

SEE HOW THE JOBBERS IN THE WORLD CAN SUPPLY YOUR WANTS.

MORE NEED OF CO-OPERATION.

The Final Settlement of the Rooney Bankruptcy Matter Serves to Illustrate the Value of Creditors Co-operating with One Another and Appointing a Receiver Who Is Interested in the Adjustment of the Bankrupt's Affairs.

Judge Hand last week confirmed a composition of John J. Rooney, a dealer in talking machines at 1983 Broadway, New York, with creditors at 33 1-3 cents on the dollar. The Rooney stock of machines and records was purchased from the receiver in bankruptcy some time ago by A. H. Mayers, of 790 Ninth avenue, New York.

The final settlement of this bankruptcy case serves to illustrate the value of creditors co-operating with one another, and of appointing as a receiver one who is actively interested in the successful adjustment of the bankrupt's affairs. In this case the principal creditors held a meeting as soon as the bankruptcy was an established fact, and as they realized that a business administration would be best given by someone experienced, J. Newcomb Blackman, president of the Blackman Talking Machine Co., 97 Chambers street, New York, and one of the largest creditors involved in the bankruptcy, was appointed receiver.

Mr. Blackman immediately took hold of the business, and conducted it for a short while in order to find out just how matters stood. Incidentally, in connection with his work as receiver, Mr. Blackman ascertained that there were further assets obtainable other than those outlined in the schedule. By careful work, which was due in a considerable measure to the co-operation of the principal creditors, the receiver was able to get the bankrupt to raise sufficient cash so that a compromise settlement was eventually obtained of 33 1-3 cents on the dollar, whereas under ordinary conditions, with legal matters interfering, a settlement of 15 per cent. would have been the maximum amount offered the creditors. Of course, it should be considered that Mr. Blackman saved the

creditors from \$600 to \$700, through his detailed knowledge of the business and by acting as receiver, as he asked no customary receiver's compensation, which is usually considerable.

When interviewed by a representative of The World regarding his connection with this case, Mr. Blackman remarked as follows: "My experience in this case has merely confirmed what I have always maintained, namely, that any dealer who is in financial troubles will find it advisable to get in touch with his creditors, and secure their co-operation and help, rather than hurry to the nearest attorney, who is not in a position to render him the assistance that his creditors can and are willing to offer.

"The dealer will often find that by securing the co-operation of his creditors he will be actually saved from bankruptcy instead of being plunged into it by hurrying for legal help. The people who have every reason to help the dealer in his financial troubles are his creditors, and even in this particular case we could have rendered the dealer valuable help if he had co-operated with us long ago."

TERRITORY MUCH ENLARGED.

Columbia Store in Spokane Now Has Western Half of Montana, Which with Eastern Washington and Northern Idaho Makes One of Best Working Territories in the Country.

(Special to The Talking Machine World.)

SPokane, WASH., July 3.—Willis S. Storms, local manager of the Columbia Graphophone Co., has just returned from a trip into Canada, where he visited the cities of Vancouver and Victoria. He found that while conditions in these cities are below normal the talking machine trade seems to be exceptionally active. T. A. Switzer, managing director of Fletcher Bros. in these cities, stated that their business had been very satisfactory. This firm are Columbia jobbers for British Columbia and report a big demand for the new Mignonette.

In a chat with Mr. Storms, he said: "We are preparing for the largest fall trade in our history. George W. Lyle, general manager of the business, has recently given us the western half of Montana, which territory was originally handled by the Sheuberg Drug Co., of Livingston. With this territory added to eastern Washington and northern Idaho, which we now control, we have one of the best territories in the United States in which to operate. It is safe to say that there are probably more goods in our line sold right in the State of Montana than in any other State in the Union. I expect to make an extended trip through Montana the latter part of August, calling upon the trade."

The local Columbia store has placed an order with the Curran Electric Sign Co., of Spokane, for a large electric sign, reading, "Columbia Gramophones." This will be one of the most attractive and largest signs in the city.

MUSIC SOOTHES HIS COWS.

Tunes from the Phonograph Also Make Them Give More Milk.

(Special to The Talking Machine World.)

MIDDLETOWN, N. Y., July 8.—Robert A. Harrat, a dairyman at Bloomingburg, near here, reports that he has installed a phonograph in his barn for use at milking time. The dairyman's object has been to increase the flow of milk from the cows through the playing of soothing melodies, and he declares that the experiment has fully equaled his expectations.

There has been a marked increase in the flow of milk and the cows appear to fully appreciate the music, as they are as gentle as lambs. Harrat claims that the average increase from each cow is about two quarts, and he believes that it will be still larger as the season advances.

I. W. Guisinger, a well-known piano dealer of Fayetteville, Ark., was a visitor to New York early in the month. While here Mr. Guisinger, who maintains a successful Victor department, spent some time at the headquarters of the New York Talking Machine Co., 81 Chambers street.

Twelve Years of Service Giving

That's our record.
We know the thing a dealer appreciates most is service—quick service.

The principal Victor dealers throughout Ohio "bank" on us to give them the goods—quick.

To be sure, at times we are short on goods, but who isn't?

What we have you get quick.

Just let us have that next order, please.

The Perry B. Whitsit Co.
COLUMBUS, OHIO

PERFECT IN EVERY DETAIL



ARTISTIC
BUILT LIKE A WATCH
COMPACT, POWERFUL

Thousands of satisfied users bespeak its excellence.

Send 50 cents stamps for sample. Write on your business letter-head only. Place regular order through your jobber.

**STANDARD GRAMAPHONE
APPLIANCE COMPANY**
173 Lafayette St., New York



LOUIS XVI
Model A450, Circassian
Walnut, \$450.00
Model A400, Mahogany,
\$400.00



SHERATON
Model A275 M
Mahogany, 1 1/2
Plain, \$270.00

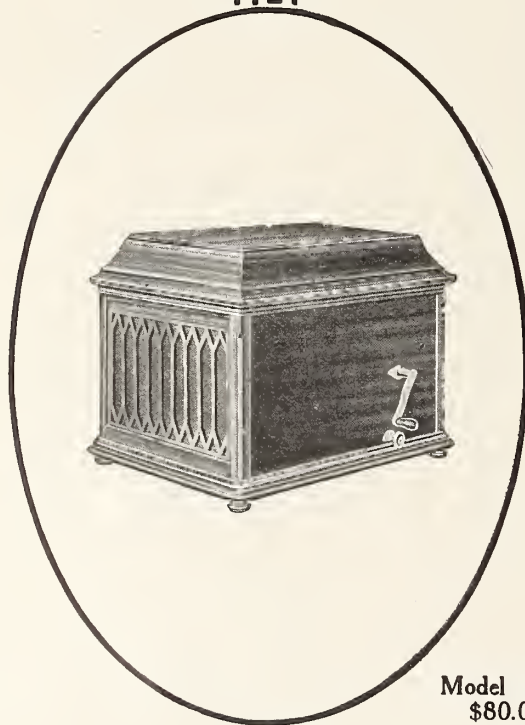

Model A80, Mahogany,
\$80.00

Permanency

Ever think how many things there are about an Edison Phonograph associated with the idea of permanency?

There's the permanent diamond point that has done away forever with the bother of changing needles. There's the Edison record, impervious to wear, practically indestructible, and there's the never changing efficiency of the motor. Above all, there's the permanency of the Edison Phonograph's tone quality that makes it the constant leader.

All these things mean the permanent enthusiasm of permanent customers. In

Thomas A. Edison, Inc.

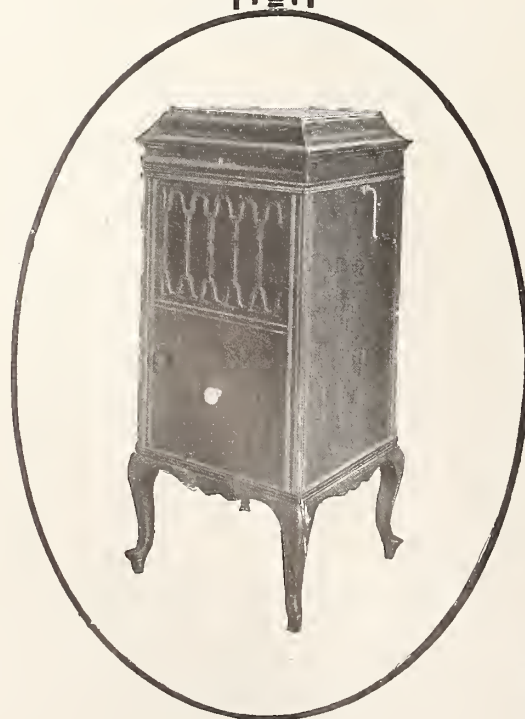

Model A200, Mahogany
and Oak, \$200.00



Model A30, Cir
cassian Walnut
\$300.00



BRATON
A290, Ma-
y, Inlaid
quetry,
00

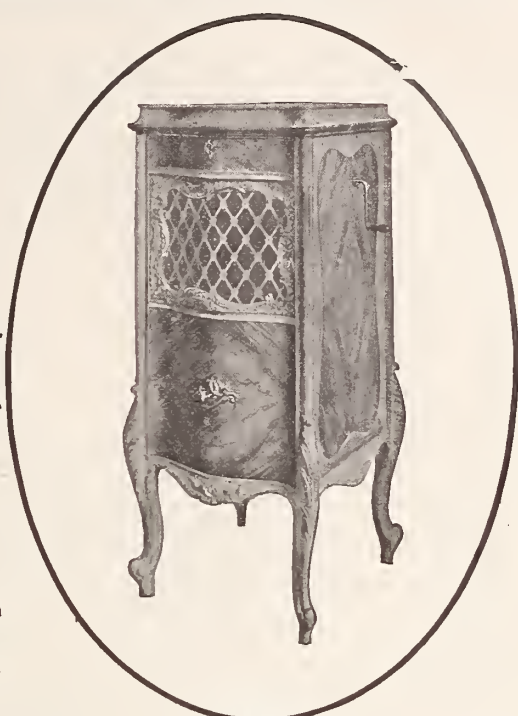

LOUIS XV
Model A425, Circassian
Walnut, \$425.00
Model A375, Mahogany,
\$375.00

parasmodic sales to stray purchasers there's no profit to you. You want customers who will come back to you with new trade because they are convinced that the Edison Phonograph is the one instrument that they can go on enthusing over. You're after the type of customer who shares his enthusiasm with his friends, and who's interested in every phase of the phonograph's development.

To meet every demand of all sorts of customers it is necessary that you handle the full line of Edison Phonographs. It's no trouble to create the desire for an Edison Phonograph. The customer who hears a few records played inevitably and instantly acquires it. But you do not want to let that man go out of your store unsatisfied because he cannot find the type of instrument that he wants at the price he wants to pay.

We will gladly send you the name of the nearest jobber who will tell you about terms and prices.

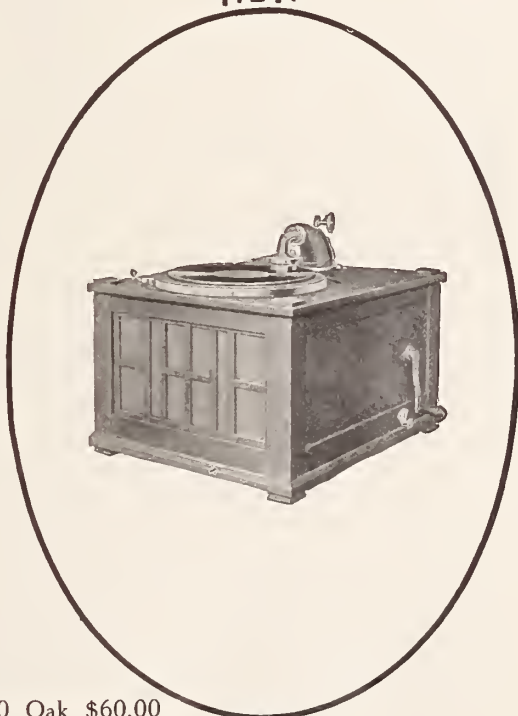

Model B60, Oak, \$60.00

Lakeside Ave., Orange, N. J.



A250, Ma-
and Oak,
00



Model A150, Mahogany
and Oak, \$150.00

SWITKY'S

Service

With

Intelligent

Treatment

VICTOR
DISTRIBUTOR

TRADE ADVANCE IN OUAKER CITY

For the Six Months of 1914 Reported by Majority of Talking Machine Men—Preparing for Lively Fall—Wanamaker Department Enlarged—Attend Jobbers' Convention.

(Special to The Talking Machine World.)

PHILADELPHIA, PA., July 9.—And still the business in Philadelphia is showing a substantial advance. During every one of the first six months of this year the Philadelphia dealers in talking machines have run considerably ahead of last year. The dealers are not so certain that this condition will continue, although naturally they are hoping for the best.

There is very little change in the situation here and no new dealers have entered the field. The firms all seem to be preparing for a hot fall campaign. The Edison proposition was sprung upon the dealers pretty late in the active season, and those who have taken that instrument are laying low, awaiting developments.

Wanamakers have made a great improvement in their talking machine department and have doubled their number of booths, which brings their Louis XIV room in the center of the department, and which they will hereafter use as a demonstration room for the general public. On the days following the arrival of the new Victor records this room is overcrowded with enthusiasts. They will not use all of the new rooms they have constructed for their talking machine department, but will devote several of them to small goods, which are now across the aisle on the same floor. They will go more extensively into the handling of such goods the coming active season. Both Manager Comerer and J. C. Angle attended the sessions at the Atlantic City convention this week.

All three members of the firm of H. A. Weymann & Son are at Atlantic City most of the week, and will be at Harry W. Weymann's cottage at Chelsea. The head of the firm reports that the talking machine business has been very active.

The past several weeks have been active at the Victor factory in Camden on account of the Lubin Co. taking moving pictures of the various departments, which were shown to the dealers during the convention. This exhibition was no doubt one of the features of the convention.

Connor & O'Neill report their business at 103 South Twelfth street has been keeping up very well. They are doing an exceptionally heavy repair and adjustment work, which is in charge of W. A. Sheppard, a man of wide experience.

Emil Bauer is continuing to act as special selling agent for the Keen-o-Phone talking machines, with offices at 214-18 South Twelfth street. He is disposing of all the stock still on hand.

Manager Eckhart, of the Pennsylvania Talking Machine Co., who has refurnished his private office, says he is very optimistic over the business situation and believes he is justified in getting ready for the biggest fall business his firm has ever had. He has been making a flying visit among

increased business, which affected its piano and talking machine departments to the extent that in the latter it sold more than double the number of machines it did during June of a year ago, and an even greater percentage of records.

Gimbels have their plans laid for an extensive enlargement of their talking machine department this fall.

NORTHERN OHIO DEALERS ORGANIZE.

Form Organization at Meeting Held in Cleveland and Elect Officers—Plan to Hold Monthly Meetings to Discuss Trade Promotion.

(Special to The Talking Machine World.)

CLEVELAND, O., July 8.—The Victor talking machine dealers of northern Ohio have organized an association, and held their first meeting in the Advertising Club rooms at the Hollenden Hotel, June 1. There were twenty of the local dealers and jobbers present. The following officers were elected: W. G. Bowie, president, of the B. Dreher's Sons Co.; O. E. Kellogg, vice-president, of the H. E. McMillin & Son Co.; G. F. Smith, secretary, of the Euclid Music Co., and R. W. Schirring, treasurer, of the Caldwell Piano Co. The executive committee consists of the officers and Phillip Dorn, of the Collister & Sayle Co.; P. J. Towell, of the Eclipse Musical Co., and James Card, of the W. H. Buescher & Sons Co. The association will meet the second Monday of each month and discuss plans for the promotion and elevation of trade interests, and for social intercourse.

Valabhdas Runchordas, of the Talking Machine & Indian Record Co., whose main office is in Bombay, India, sailed from that city recently for Europe. It is his intention to visit Switzerland, and from there he goes to London, Berlin, Hamburg and possibly New York. The Talking Machine & Indian Record Co. has built up a great business in India, and issues a lot of literature covering talking machines and records, which is published in English and in the native languages.

Keeps

You

'Satisfied

SERVICE

NEW YORK CITY

all of his dealers and is well satisfied with conditions as he found them. Mr. Eckhart is shaping matters so that he will be able to take a short trip to Europe at the end of July. One day early this week Mr. Eckhart was in Atlantic City assisting in the installation of the Columbia Grafonola at "The Garden of Dances," one of the greatest dance halls in America.

Louis Buehn has added another man, George L. Austin, to his Edison dictating machine department. He has done a heavy business in this department in June, having placed new machines with the Barber Asphalt Co., the Millville, N. J., Manufacturing Co., H. C. Kahn, the big instalment man; John T. Lewis Bros., R. G. Dun & Co., the Philadelphia Electric Co., the Lehigh Coal & Navigation Co. and the New England Cotton Co. Like the other firms here, Mr. Buehn notes a substantial increase in his talking machine department.

During June the Strawbridge & Clothier firm held its forty-sixth anniversary and advertised it heavily, and in consequence it had a greatly



Columbia dealers are holding a mid-summer Convention of their own, largely attended by people who have money to spend.



(Write for "Music Money," a book "full of meat" for those dealers interested in quick and frequent turnover of capital.)

**Columbia Graphophone Company
Woolworth Building, New York**

CLEVELAND DEALERS ARE REPLENISHING STOCKS.

Will Not Be Caught Napping the Coming Fall and Winter—Business, However, Not Quite as Brisk as Previous Months—W. H. Buescher & Sons Co. Lease Warerooms for Exclusive Jobbing Business—Masters of Dancing Praise the Columbia Grafonola.

(Special to The Talking Machine World.)

CLEVELAND, O., July 8.—There has been no material change in the talking machine trade in Cleveland during the past month. Business was not quite so brisk generally, but the volume was sufficient to keep the dealers busy and hopefully confident. Dealers are all putting forth efforts to increase business and are replenishing stocks to meet increasing demands. While there is still some complaint among Victor dealers, supplies are more readily obtained than heretofore, and there is a better feeling in the respect all around.

The W. H. Buescher & Sons Co. has leased a wareroom containing 11,000 square feet of space on Chestnut street, where an exclusive Victor jobbing store has been opened. The new store is one block from the present retail location. It has been fitted up in attractive style, with special facilities for handling the business expeditiously.

Warren L. Kellogg, traveling representative of the Victor Co., Camden, a brother of O. E. Kellogg, secretary of the H. E. McMillin & Son Co., was a visitor at the store recently.

F. D. Witt, of the Witt Music Co., at Lorain and Elyria, Columbia dealer, was a visitor at the local Columbia store this week. He said business was satisfactory and as good as expected at this season of the year. The following new Columbia dealers were scheduled at the local store the past month: W. H. Hetrick & Co., Oak Harbor, O.; J. V. Hartel, Barberton and Wadsworth, O.; Carnahan Music Store, Ravenna, O.

Notwithstanding the fact that weather conditions have been adverse, the business of the Grafonola Co. has far exceeded the expectations of Mr. Routh, who says he believes in going after outside business strong, and that even in the hottest weather, when people will not stir from their homes, they will buy if the goods are taken to them. An auto, he says, is of great assistance in cooling the customer off on a hot evening and putting him in a frame of mind to purchase a \$200 Grafonola when he contemplates an investment of a \$50 machine.

The Eclipse Musical Co., notwithstanding the slowing down in business, is doing nicely in both the wholesale and retail departments. Good sales of Victor machines are being made.

Phil Dorn, of the Collister & ayle Co., says business is good, considerably ahead of last year at this season, and that the prospects are flattering.

Manager Madson, of the Columbia store, was greatly pleased at the receipt of the following communication, dated Pittsburgh, Pa., June 15, 1914, and addressed to the Columbia Graphophone Co., Cleveland. It read:

"Gentlemen: At a regular meeting of the American National Association Masters of Dancing, in convention at the Hotel Statler, Cleveland, O., this convention highly indorses and recommends the

use of Columbia Grafonolas and Columbia dance records for the use of our members. Your records are played in perfect dance time and their reproduction by your instruments enables us to enthusiastically indorse your product for our use. Very truly yours, The American National Association Masters of Dancing, Thomas McDougall, Secretary."

The Phonograph Co. registered the usual quota of Edison business during the past month. Mr. Bloom, secretary, stated trade was moving briskly, about normal for the season. Retail dealers, he said, were doing well all along the line.

The H. E. McMillin & Son Co. has been making a number of improvements in the Victrola depart-

BUYING A RECORD.

An Experience Rather Familiar to Salesmen in the Talking Machine Store, but Which Is Interesting to the General Public.

He rushed into the talking machine department of the store about 5 o'clock in the afternoon and said to the young woman in charge:

"My wife told me to run in here and get a 12-inch record of—let me see; oh, what is it? Well, I can't remember it. I've got it written down somewhere. Just let me find it."

But a five minute search through his multitudinous pockets failed to find a trace of his memorandum, and he was much perturbed.

"She's got to have it to-night, too," he continued. "Lot of people coming to spend the evening. Very musical, too. They'll all want to hear this."

"Is it a song or an instrumental number?" helpfully asked the young woman.

"Blamed if I can tell you," rasped the customer, "and I've only ten minutes to get my car, too. Have to wait twenty minutes if I miss that one. Let's see. As near as I can remember it's something about pegs. I think I'd know it if I heard it. Pegs, I think it is. Yes, pegs. What have you got in fresh pegs, I mean just pegs?"

The nonplussed saleswoman thought a moment and suggested "Peg o' My Heart."

ment during the past month, but it evidently has not interfered with the demand for sales of Victors. Mr. Kellogg expressed himself pleased with the showing.

Mr. McNulty, of the Union Specialty & Plating Co., is a very happy man these days, owing to the fact that there is no let-up to the demand for Union talking machine specialties. He says everything is running nicely, and that the factory is kept busy continuously on its products.

Activity is manifest in the talking machine and music department of the Bailey Co., and Mr. Friedlander reports some excellent sales of machines and records during the past month.

The various members of the trade are all most optimistic regarding the prospects for the late summer and fall, and this is the report made by T. A. Davies, manager of the talking machine department of William Taylor, Son & Co.; R. W. Shirring, manager of the talking machine department of the Caldwell Piano Co.; the Euclid Music Co., W. H. Buescher & Sons Co. and H. M. Brainard Co.

"No, that isn't it," fumed the little man, "nothin' as sensible as that. I'd 'a' remembered that."

"Well, perhaps it's a violin solo of Paganini's." "Nope. You're nearer, though. It's about as crazy as that. Try again."

"Well, we have a comic number called 'Peg Along;' could that be it?"

"Oh, no, no, no! That isn't it. It's something highfalutin."

"Well, it may not be peg at all. Might it not be nail, tack, screw or tie? How about 'Thais?'"

"Nothin' doin'. It's peg, as near as I could get it on the paper wife wrote out for me."

After another five minutes had been wasted the young woman had an inspiration. She handed him a catalog and said:

"Suppose you look over this; you may see it."

He grabbed it out of her extended hand, clapped a pair of eyeglasses upon his eyes, opened his mouth and was soon going down the list with an index finger. In a minute more he was pointing to the prologue from "Pagliacci," as sung by Scotti, and exclaiming:

"Here it is! Here it is! Didn't I tell you it looked something like peg? Get me one and wrap it up, quick. How much? Here you are, even change. Now give it to me and let me run. I'll make that car yet. And next time wife wants some of that dago canned stuff she can get it herself!"—The Sun.

THE TALKING MACHINE CO.

OF TEXAS

Exclusively Wholesale

AUSTIN, TEXAS



EDWARD LYMAN BILL, - - - Editor and Proprietor.

J. B. SPILLANE, Managing Editor.

Trade Representatives: GLAD. HENDERSON, C. CHACE, L. E. BOWERS, B. BRITAIN WILSON, A. J. NICKLIN, AUGUST J. TIMPE, L. M. ROBINSON.

Boston: JOHN H. WILSON, 324 Washington Street.

Chicago Office: E. P. VAN HARTINGEN, Consumers' Building, 220 South State Street.

HENRY S. KINGWILL, Associate. Telephone, Wabash 5774.

London, Eng., Office: 2 Gresham Buildings, Basinghall St. W. LIONEL STURDY, Manager.
Representatives for Germany and Austria: VERLAG NEC SINIT, Berlin C. 19, Ross-Strasse 6, Germany. GEO. ROTHGIESER, Director.

The Talking Machine World has regular correspondents located in all of the principal cities throughout America.

Published the 15th of every month at 373 Fourth Ave., New York.

SUBSCRIPTION (including postage), United States, Mexico, \$1.00 per Year; Canada, \$1.25; all other countries, \$1.75.

ADVERTISEMENTS: \$3.00 per inch, single column, per insertion. On quarterly or yearly contracts a special discount is allowed. Advertising pages, \$100.00.

REMITTANCES: should be made payable to Edward Lyman Bill by check or Post Office Money Order.

NOTICE TO ADVERTISERS.—Advertising copy should reach this office by the first of each month. By following this rule clients will greatly facilitate work at the publication headquarters.

Long Distance Telephones—Numbers 5982-5983 Madison Sq.
Cable Address: "Elbill," New York.

NEW YORK, JULY 15, 1914.

THE 1914 Convention of the National Association of Talking Machine Jobbers is fully reported elsewhere in this publication, and unquestionably every member of the trade who journeyed to Atlantic City to attend the national meet felt more than repaid by what he heard and what he saw.

The members of the Committee of Arrangements certainly deserve credit for the excellent manner in which they worked out all the details in connection with the Convention program. They overlooked nothing which would make for the entertainment of the delegates, and certainly a record was established which will be difficult to overtop in future years.

The demonstration given by the Victor Talking Machine Co. by a series of moving pictures of the different departments of the Victor factory was a remarkable contribution to the entertainment of the Conventionists. Never before in the history of conventions have the selling forces of an industry been permitted to view in detail by a series of moving pictures an entire factory organization. At an expense of thousands of dollars the Victor directors presented an actual demonstration of the different departments of their enterprise. Even if all of the beholders had been permitted to view the factories individually they could hardly have gotten such a comprehensive idea of the entire manufacturing enterprise as was presented to them by the means of moving pictures at the Atlantic City Convention.

There are few manufacturing firms in the world, if any, who would have gone to such an expense in order to show the workings of their creative department to their representatives. The Victor Co., however, has never stopped at the cost of any enterprise which it deemed of benefit to its factors.

The inner glimpses of the Victor factory were entertaining and instructive, and needless to add, the social part of the Victor entertainment was along the same generous lines which has characterized the hospitality of the Victor officials on former occasions.

When you say that an entertainment was up to the Victor grade, it means that there was nothing left undone that could have added to the pleasure and comfort of the guests.

THERE is no denying the fact that the general business of the country is not up to grade.

There is no denying the fact that trade in all lines is suffering, and there is no denying the fact that this condition is not merely psychological. You cannot supply a man with psychological business and psychological money and help him out of a depressed condition when he wants actual trade and hard cash.

There is no denying the fact that the people as a whole are interested in seeing this country adjust itself to the present conditions before new and possibly indigestible laws are placed upon our statutes.

There is no denying the fact that the country as a whole will take an optimistic view of the business future if the politicians will only permit them an opportunity to do so.

There is no denying the fact that one of the best reasons for optimism at the present time is found in the promise of abundant crops.

There is no denying the fact that this condition will help immeasurably to pump new life into the dried arteries of trade.

The wealth of the harvest fields will soon be a powerful factor in aiding stagnant trade, but how about the talking machine business? That is of particular interest to World readers.

Talking machine dealers certainly rank among the most fortunate of all men engaged in trade, and, during the summer, which is admittedly dull, the talking machine institutions are busy.

And why?

Because the summer hotels, camping out parties, country clubs and yacht clubs are all purchasers of talking machines and records.

Now that all of the world is out of doors, all the world demands to be entertained, and the great big national entertainer is the talking machine.

It is surprising how the talking machine has superseded instrumental musicians in every way. Take the thousands of informal dances—it is the talking machine that supplies the music rather than some local orchestra. Now that the "thé dansant" has captured the world, the talking machine comes in as its chief accessory. Go out to almost any summer hotel and you will find not merely one little dancing party, but a number during the evening, and you will find the one source supplying the musical entertainment is the talking machine.

The unusual summer activity in talking machine circles is but a logical development of the tango spirit which has been pulsing through all America during the winter months. This is a spirit that the live talking machine dealers are profiting by. They realize the strength of their position and they are improving it as they should.

VACATION time makes the talking machine business good in every part of the country, and there is precisely where the men in the trade to which The World directly appeals are in an enviable position compared with the general merchant; but this business will not come to every man unless he improves his opportunities. That is hardly to be expected, but we are perfectly correct in saying that the talking machine dealer belongs to the trade elect more especially this summer than during any other. Instead of the season being a stagnant one, it should be particularly good, and it will be if the progressive element of the trade realizes what taking advantage of the tango, hesitation, maxixe, one-step condition means.

If every dealer would make a systematic campaign of his local territory—figure out the number of summer hotels, boarding houses, outdoor clubs and parties and canvass them, he would win profitable trade in return for his efforts. Get out attractive literature to the managers, show them how the talking machine will aid as an entertainer, that it should be a feature that they cannot overlook. Make all those points clear, not once but several times. In other words, improve the present opportunities to the utmost. Go at the development of summer trade with well directed effort, because to succeed even moderately well one must concentrate, and in that way direct results may be secured.

IT is useless to say that trade will come crowding in at your door, even if you have a most attractive proposition. To assume such a condition is to admit business defeat and to show incompetence.

The day of random effort is past. Definiteness and concentration make for the elimination of useless effort.

Concentrating your efforts intelligently upon the building up of the talking machine trade during the summer months will insure you success. It will stamp you as an efficient business man and show that you realize the trade possibilities of your profession.

Scan the history of the big and successful houses in this trade,

or in any other trade for that matter, and you will find invariably that they pursued a definite business policy—that they concentrated their efforts along certain lines until they succeeded, and then moved on to other points.

THE man who wins is the one who concentrates and who devotes himself to his work, and does not the talking machine with its wonderful entertainment possibilities come in as a rare trade stimulator during vacation?

Try concentrated action on the development of your summer trade. Get right down to brass tacks and make up your mind to do your work well.

Succeed! Of course, you will. But do not stop in thinking success—work for success. Keep at it and the results will astonish you.

Really the more one goes into the entertaining powers of the talking machine the more admiration must be developed for it, and right here is where salesmen could materially aid in building up their own income earning powers—if they would place a little more enthusiasm—ginger, if you will—into their work.

This can be accomplished by increasing their interest in the possibilities of the talking machine, not merely as a means to build an income for themselves, but as a means to entertain and charm purchasers.

It truly is a marvelous creation and the more you analyze it, the more you go into it, so much the more those essential features become impressed upon our being.

Develop new trade in hot weather? Of course, you can, and plenty of it.

EVERY talking machine dealer in these good old United States should read *The World*. Thousands of them do, and they secure from it pointers which are of value to them.

Live advertisers know that *The World* is read, and that as a business getter its power is growing all the while.

The progressive jobbers know that publicity in *The World* columns pays them and it keeps their business constantly before the dealers of their territory.

Here is a communication received from the manager of the Little One-der Co., of Nashville, Tenn., manufacturer of a recently perfected accessory. Under date of June 20 the manager writes to *The World*:

"During the last 20 years I have spent possibly millions of dollars in advertising in trade papers—more particularly in engineering papers, steel papers and those devoted to the coal industry. I have come across some good ones, but, speaking of trade papers, I want to tell you that *The Talking Machine World*, in my opinion, is the 'daddy' of them all.

"I got my copy last night, containing our advertisement, and, of course, there has hardly been time for your subscribers to read their copies and send a letter through the mails to reach here. Notwithstanding this fact, in this morning's mail we have four orders—which, I may say, is more than I got from all of my advertising in some of the big associated magazines and in some of the well-known weekly and monthly national magazines—the cost of advertising in same being an approximate total of \$200.

"I look upon this morning's mail as a beginning, and, if it keeps up this way, I don't know just where we will finish.

"Another thing, whereas the orders from the magazines are from consumers who order one attachment, your orders are from dealers who order in bulk.

"Needless to say, I want you to continue the advertisement—although the results are so good we do not seem to need any more advertising.

"This letter is quite unsolicited, and if you care to use it in advocating your magazine as the most successful medium for bringing quickly to dealers the merits of a new device, you are at perfect liberty to do so."

Get *The World* habit—it is good to have. J. H. Hoffay, London, writes: "I have received four hundred replies to a single advertisement in the *May World*."

These are just two of the many illustrations showing that *The World* as a stimulating power to trade is excellent. If you are a jobber be proud of your business, as you should be, represented in every issue of the one paper which fairly and thoroughly represents your trade.

DITSON Victor Service

Is Supreme in New England

Your first order will prove
this—fast and complete—
Machines and Records.

OLIVER DITSON COMPANY
BOSTON, MASS.



THE DITSON BUILDING AT BOSTON.

We will help you make money in 33 languages

How many foreigners are there in your locality? Italian, Hungarian, German, Jewish, Bohemian, Russian, Swedish, Polish—or whatever their mother-tongue may be?

Do you realize how anxious they are to spend their money in your store?



Columbia Records—a splendid repertory in all of the following languages—and a correct catalog for each:

- | | |
|---------------|--------------------|
| Arabic-Syrian | Finnish |
| Armenian | French-Canadian |
| Bohemian | Gaelic |
| Chinese | German-Austrian |
| Cuban | Greek |
| Danish | Hawaiian |
| | Hebrew-Jewish |
| | Hungarian |
| | Italian-Neapolitan |
| | Japanese |
| | Javanese |
| | Lithuanian |
| | Mexican |
| | Norwegian |
| | Polish |
| | Portuguese |
| | Roumanian |
| | Russian |
| | Ruthenian |
| | Scotch |
| | Serbo-Croatian |
| | Slavish-(Krainer) |
| | Slovak |
| | Spanish |
| | Swedish |
| | Turkish |
| | Welsh |

YOU know well enough that music means ten times more to the foreigner in your town than to the American citizen. Especially the music of his own native land—and even more especially if it is sung by the best known artists and played by the best known instrumentalists of his own country—names as familiar to him as your own front door is to you.

We are now prepared not only with a remarkable series of records in 33 languages and dialects, but with the means of getting the business for you.

Our Foreign Record Department will co-operate with you to the limit; we can tell you very nearly how many foreigners there are in reach of your store—and we have a pretty clear idea of what language they speak, too. And we can tell you just how to go about bringing them in. It's the easiest thing in the world—once you have been put in touch with them they will come to you.

The Columbia repertory of foreign records is by far the biggest and best in every language. Most of them were recorded in Europe, and all of them are in the pure native language or dialect.

Good business in every month of the year—no dull summer months for you if you have this highly profitable foreign trade coming in. We can tell you how, and we can help you do it!

Write for particulars to the Foreign Record Department
102 West Thirty-Eighth Street, New York City



Graphophone Company, Woolworth Bldg., N. Y.





For every argument that might occur to you as to the wisdom of not carrying Columbia Grafonolas and Records along with competitive product we will show you a letter from a dealer who has gotten by the argument stage and has the proof right in his bankbook.



(Write for "Music Money," a book "full of meat" for those dealers interested in quick and frequent turnover of capital.)

Columbia Graphophone Company
Woolworth Building, New York

TRADE NEWS FROM CINCINNATI.

Cable Company Installs Victrola Department—Leading Jobbers Report an Excellent Volume of June Business Despite Unusually Hot Weather—Second Hand Talking Machines Utilized for Children's Playgrounds.

(Special to The Talking Machine World.)

CINCINNATI, O., July 7.—One of the real surprises of the past month was the announcement that the Cable Company's branch in this city would soon have a Victrola department. In fact Wholesale Manager Summey is now looking for an enterprising manager, and is already figuring on letting contracts for a series of booths with a view of having these ready for business by August 1. Some stationery, calling attention to the new field of this piano house, has made its appearance.

Manager Rudolph Dittrich, of the talking machine department of the Rudolph Wurlitzer Co., left Thursday evening for Atlantic City, to take part in the annual meeting of the talking machine jobbers which opened Monday. Just before leaving, in speaking of the business in his department, he said:

"The month of June being one of the hottest and driest on record in Cincinnati, naturally did not show favorable conditions for the talking machine trade, but even with adverse conditions existing, we made a very creditable showing. With the people leaving in large numbers for summer resorts, and with the remaining number much interested in planning their vacations, there was comparatively very little opportunity of pushing the sale of Victor goods very extensively. The exception which the demand for small Victrolas created modified the conditions somewhat."

The new Victrolas, Styles Nos. 10 and 11, have been received and have made a great impression on the trade. There is no question but what these improvements will greatly increase the sales of these two popular types and that they will develop a field of their own without injuring to any great extent the sales of Victrolas Nos. 14 and 16.

The local Columbia store reports remarkably good business, both wholesale and retail, in June.

In speaking of the matter Manager Whelen said: "When you consider that it was June, we more than held our own and we anticipate a good summer business. We feel, considering what others say, that we are fortunate. The dance craze still continues and is an added stimulus to the summer business. We have had especially heavy calls for the new dance instruction records both retail and from the dealers.

"The exclusive engagement of Joan Sawyer, the famous dancing star, and her Persian Garden Orchestra brings another of the most famous dancers of the day into association with the Columbia Co., and her records have created quite a furore among the dance loving public."

Ben L. Brown, the assistant manager of the local Columbia store, was in New York the first of the month visiting the executive offices and making a tour of the factory at Bridgeport.

Cliff Herdman, formerly connected with the Columbia Graphophone store in this city, but now manager at St. Paul, Minn., spent ten days in Cincinnati renewing old acquaintances. Mr. Herdman was always a favorite and his visit was very much enjoyed by his former associates in the Cincinnati store.

J. D. Westervelt, supervisor of Dictaphone agencies made a flying trip to Cincinnati and left very well satisfied with the local Dictaphone situation.

The Lyric Piano Co. enjoyed a fairly good business last month. The Victrola department of the Otto Grau Piano Co. is now well established and has proven quite a success. Mr. Strief, manager of the Victrola department of the Milner Musical Co., is disposing of all second-hand talking machines of obsolete makes, but which are in good running condition and capable of making good music in an original and very useful manner. He is turning these machines over to the Board of Park Commissioners for use in the Children's Playgrounds. Cincinnati takes considerable pride in her splendid parks and playgrounds. A number of the playgrounds already have pianos and with a talking machine furnished by the Milner Musical Co. their equipment along the musical line will be complete.

Business with the Milner Musical Co. has been extremely satisfactory during the past month. Many small outfits are being sold to campers and to parties leaving the city for summer homes along the Great Lakes.

THE MAN WHO TOOK ADVICE.

The Merchant Who Actually Succeeded in Spite of the "Listen to Me Stuff."

Once upon a time (as all good fairy stories begin) there was a man who actually took advice. He was the joy and satisfaction of the entire neighborhood; and whenever any gabby resident of those parts ribbed up a lot of "now-listen-to-me" stuff, he knew that the man who lived in the little gray house on the corner would eat it up and ask for more.

The strange part of it was that after years of advice-taking the man in the gray house kept right on prospering. He didn't fail; he didn't go into the hands of a receiver; he didn't have to shoot his life insurance into a pawnshop in order to pull out a beefsteak, says the Whitaker Paper Co.'s Paragraph.

So one day the Curious Guy in the middle of the block spread his feet out, poked his finger at the prosperous man's middle vest button, and demanded:

"What's your recipe?"

To which the Prosperous Man replied promptly: "Why, I take everybody's advice. I've taken a lot of yours, if you must know. It's hard to do, but—"

The Wise Guy shook his head. "I never knew it to work before," said he in a whispered aside.

"But," continued the Prosperous Man, "I took your advice and the advice of everybody else and—coppered it—went the other way.

"Your advice is all in perfectly good condition, stored away down cellar; any time you want it, or any time any of my other good friends want it, it's yours for the asking. Perfectly good, unused, and worth exactly as much as the day it was given to me."

Moral—But all of us don't know when to play the red in place of the black!

READY REFERENCE OF GENERAL SUPPLIES

DEALERS

Send for our "Trial Proposition" on the Regina Hexaphone—the latest and best paying popular priced coin-operated instrument for use in public places.

THE REGINA CO.

211 Marbridge Bldg., 34th St. and Broadway, New York City
Manufacturers of Regina Music Boxes; Reginaphones;
Coin-operated Mandolin Orchestrons; Vacuum
Cleaners and other specialties.

Mermod & Co.

505 Fifth Avenue New York

Manufacturers of

Talking Machine Supplies

Motors—Sapphire Points

Diamond Points a Specialty

Keep Your Record Stock with

THE
Heise
SYSTEM
TRADE MARK

Costs about \$2.00 for 250 records for 50 years
Send for 20-page catalog

THE SYRACUSE WIRE WORKS,
SYRACUSE NEW YORK

Albums for Victor, Columbia and Edison Records



We are making the most complete line of record albums on the market, including the regular 16 or 17 pocket styles, and a new 12-pocket album, which adapts itself for use in the new cabinets with flat shelves.

The new album for Edison disc records is made with the same care and precision and of the same high-grade materials as our regular albums, except that it is spaced wider and has ten pockets.

No More Scratching of Cabinets and Tables

All our albums are equipped with the new LEATHER COVERED RING PULL, which makes the handling of the book easier than with the plain leather pull and has all the practical advantages of the metal ring.

Write for full particulars and trade prices.

NEW YORK ALBUM & CARD CO., Inc., 23-25 Lispenard Street, New York

(Formerly New York Post Card Album Mfg. Co.)

MONTHLY TOTALS SHOW NO DULL TIMES IN ST. LOUIS

Despite Complaints in Other Lines—Collections Rather Slow, However, with Jobbing Trade—Those Who Attended Convention—Jobbers Benefiting from Package Car Service—Missouri Music Teachers Approve of Talking Machines—Columbia Co. News.

(Special to The Talking Machine World.)

St. Louis, Mo., July 8.—The talking machine dealers of this community are not complaining, although they have been hit somewhat by the dull business that appears to have pervaded all lines throughout the country, but they will make a better mark than they have in previous years in monthly totals, which they says is about all that they can expect. Advertising has been rather light of late and the very unseasonable hot weather that held this entire section of the country in such close grip for three weeks caused a let up in the very sharp demand for dance records. There was the usual sharp increase in record sales for the Fourth of July. The demand for the last few weeks has been running to rather smaller machines.

The jobbing trade reports rather slow collections, but that always is the case in this country during the season when farm work is especially heavy, as the banks are making unusual demands because of the country's need for money. Cash expenses keep the farmers from paying bills and the flow of cash through the regular channels is restricted, but the increase within a few weeks will soon even things up.

Orders are fairly plentiful and of fair volume despite the vacations everywhere and all jobbers report excellent prospects for new dealers in the early fall months.

Harry Levy, of the talking machine department of Aeolian Hall, was not able to get east for the Victor convention this year as he had hoped. He is getting well settled in his new jobbing quarters in the Furniture Exchange building and reports that business is running smoothly under the new arrangement.

E. C. Rauth, secretary of the Koerber-Brenner Music Co., Victor jobbers, is planning a pleasant trip after the Atlantic City Convention. He went from here to Chicago to join the special car of Northwestern jobbers, and after the conclusion of the sessions he will join Lester Burchfield, of Sanger Bros., of Dallas, and W. H. Reynolds, of Mobile, and they will go to New Orleans on a non-stop boat. Parham Werlein, of New Orleans, is expected to join them on this trip, and Mr. Rauth probably will go from New Orleans to Mobile with Mr. Reynolds for a few days fishing on the Snapper banks near that city.

Mr. Rauth is now writing with his left hand, much to the surprise of his associates, who declare

that he writes better than he formerly did. The change came about through a severe case of writer's cramp which made his right hand entirely undependable for writing, and he was forced to learn to use his left, which he does very readily, and reports writing complete letters in long hand by his new method.

Mr. Rauth recently has been giving considerable attention to the movement to push the one-cent postage bill and is meeting with a great deal of success in organizing for this movement. He is practically a pioneer in this field.

Talking machine jobbers are among those who are profiting largely through the package car service recently inaugurated on the railroads out of St. Louis through the Business Men's League, the chief commercial organization in the city. The service is designed to load merchandise for certain districts in full cars to break bulk at a definite point for distribution. It puts Nashville, Tenn., and some Carolina in the second day delivery points and maps are issued showing in circles just what way points can be reached on the second day. The bulk breaking point usually is designated as the beginning of the local freight run so that the car can be taken out that day on the local freight run and all points reached the same day. It has been thoroughly organized on all roads and for the Southwest often solid freight trains leave for a second and third day point. The cars leave in the evening on preferred freight runs and so seldom miss their destination time that the result is practically an express delivery on freight platform at freight rate. As talking machines are seldom delivered from the jobbers in carlots, this gives to them exactly the service they have been seeking and supplies up to a five-day service which reaches the Coast both in the Northeast and Northwest. It is not infrequently the case that local talking machine jobbers ship regularly into towns within 100 miles of other jobbers and perhaps 500 miles from here with greater definiteness of arrival than the near-by jobber where this service is not organized.

At the Silverstone Music Co. the Edison disc machine continues to hold the entire force close to high speed work, and they talk of jobbing business "100 per cent. better than a year ago."

A recent caller there was J. H. Bennett, the Missourian, who recently concluded to go into the talking machine business on the ground plan of the sewing machine men of a generation ago, and who has out a number of teams and men and some crews working with autos selling machines into the homes where summer boarders are, as well as the prosperous Ozark mountain home where boarders are not needed. Mr. Bennett was looking for stock and was a liberal buyer of Edison cylinder machines, as he confines his efforts to these machines and Columbias. He entertains no doubts as to the success of his enterprise.

Miss Minnie Louise Sutter who, for a number of years, was in charge of the offices for Mr. Silverstone, was married June 30 to W. W. Oelwiller at the home of the bridegroom in Bethel, Conn. She resigned a month ago. The Silverstone

JUST TO REMIND YOU

THAT OUR LOCATION IS CENTRAL FOR ALL PARTS OF NEW YORK AND BROOKLYN AND SURROUNDING TERRITORY.

OUR OFFICE AND STOCK ROOMS ARE ONLY ONE MINUTE'S WALK FROM THE NEVINS STREET STATION OF THE SUBWAY, AND TEN MINUTES' RIDE BY SUBWAY FROM NEW YORK CITY HALL.

MESSENGER SERVICE TO ALL POINTS IN NEW YORK CITY.
VICTOR DISTRIBUTORS EXCLUSIVELY FOR 11 YEARS.
SERVICE EQUAL TO THE BEST.

BE AN "AMERICAN" DEALER

TELEPHONE 3762 MAIN

AMERICAN TALKING MACHINE CO.

368 LIVINGSTON ST.

BROOKLYN, N. Y.

Prepare for Fall Business Increase Your Record Sales

BY PLACING THIS HANDSOME FLEXIBLE
COVER IN THE HANDS OF YOUR PATRONS

This attractive flexible cover is designed to hold the Victor or Columbia semi-annual record catalog, and is bound in mahogany colored imitation leather, and lined with black silk cloth.

The price of this flexible cover is so low that it permits you to give same free to your customers with the record catalog inclosed, thereby making a useful souvenir and a *permanent* advertisement; or you may charge a nominal sum for it if you desire. In lots of 100 or more, your name will be stamped on face of cover in gilt lettering *free of charge*. Send 20c. in stamps for a sample cover, with special trade prices.

NEW YORK ALBUM & CARD CO., Inc.

23-25 Lispenard Street, NEW YORK

(Formerly New York Post Card Album Mfg. Co.)

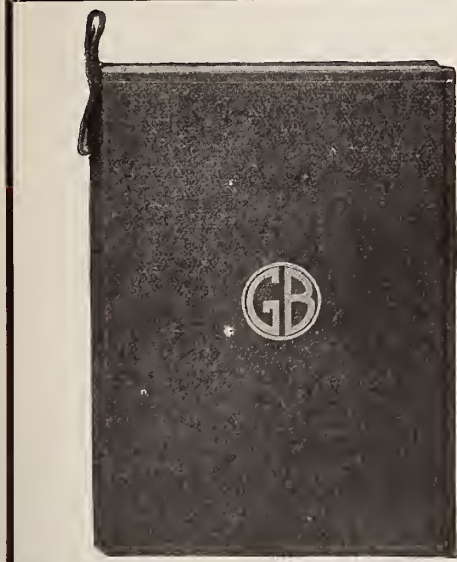

force sent to the bride a congratulatory telegram and a handsome present.

C. S. Gardner, the Edison factory representative who has been working in this territory for six months, has left for the East. During his stay in this vicinity, Mr. Gardner placed Edison disc machines with more than forty dealers and became well known to the trade and was much in demand for straightening out sales tangles and machine difficulties.

The Missouri Music Teachers' Association gave the stamp of approval to talking machines, if applause is a reliable judge. W. L. Calhoun, a music college proprietor of Carthage and Joplin, declared in an address that approval of classical music was more general than a few years ago. He declared that the increased appreciation was due chiefly to the influence of the talking machine and player-piano.

"Mechanical music devices," he said, "have put good music into the home." It is only necessary for a man to hear good music for him to prefer it to the popular kind." The remarks were freely applauded by the music teachers present.

Probably by the time this issue of *The World* reaches its readers the Columbia Co.'s local staff will be thoroughly settled in its new home. There is practically nothing of the old building left except the four walls. Floors, ceilings, roof and all interior arrangements have been changed. A ventilation system is installed and the interior is being finished at this writing and then will come new furniture, carpets, etc.

On the main floor, besides a handsome office suite that can be enclosed or thrown open as may be the wish, there are six demonstration booths with record racks of easy access. The front part of the floor will be used for machine display. The show window, larger than the two former windows, is one of the handsomest on Olive street and will admit of a splendid display. Retail Manager Duff will have desk room at one corner of the display floor space. General Manager Reid will have a private office and reception room at the rear of the main floor with both the accounting department and the order department within call and the shipping rooms and repair departments only a step away. Convenience, comfort and beauty have all been considered in the new arrangement. The lighting system is by the indirect system with silver hangings for the glass bowls that fits well into the dove and cream color scheme for the entire room.

Of course, while these changes were being made the departments were somewhat handicapped as to business, but Manager Reid says the record for a month will be a creditable one, and Retail Manager Duffy has kept his force engaged by working on the summer trade, which is sold chiefly away from the store.

The entire Columbia force is looking forward to a season of big trade. Manager Reid talks of the rain that came the first of the month in the ideal season to relieve the fears in this section that there would be no late fall crops to support the bumper wheat crop that has been harvested.

Manager Seager, of the talking machine depart-

ment of The Vandervoort Music Salon, is doing some unusual advertising work this summer. One of his first ventures was sending a fine Victor machine to Kansas City on the special train for the Elks who went there to attend the State meeting. The B. P. O. E. boys fell in with the idea for their amusement and they arranged for a "Tango Car" which was devoted to music and dancing. B. F. Martin, of the sales staff, accompanied the car to attend to the talking machine and have general charge of the amusement. The music made quite an impression on members of the party.

His second move was to present a Victor machine and \$200 worth of records to the museum department of the Board of Education for the training of teachers who care to investigate. This part of the Board of Education work is practically a training school for the city school teachers and the records available for the machine are those which fit into the scheme of the school work and they will be explained to the teachers who then can carry the idea into their own work. In this city about the only way to provide talking machines for the school is for the Patrons' Association to buy the machines with funds which are raised in connection with these organizations. Most of the pianos in the schools are bought in the same way and the teachers' wishes and expressed desires have much to do with these purchases, as the committees of the Patrons' Associations keep in close touch with the school work.

A third innovation to the credit of Mr. Seager is the introducing of a \$200 Victrola into "Dream-

land," a popular dance hall, in the place of the orchestra that is on duty in winter. The Victrola is much liked because of the different character of music that is possible for the intermissions.

The Field-Lippman Piano Stores are using the billboards to inform the public that in their talking machine department the Victor, Columbia and Edison Disc machines can be compared and the customer is free to choose the one he likes the best. The announcement is in rather unusual form, as it is a full size, eight sheet bill and carries its message in the fewest possible words in large, plain type, and adds no comment and stands out well on the large boards.

TEL-ELECTRIC CO. FALLS INTO LINE.

Arranges to Handle Talking Machines and Will Carry the Entire Columbia Line.

The Columbia Graphophone Co. closed a deal last week with the Tel-Electric Co., 299 Fifth avenue, New York, whereby this well-known piano player house will handle the complete Columbia line. Gilbert A. Pond, general sales manager of the company, is well pleased with the outlook for closing an excellent Columbia business with the Tel-Electric clientel, and has made arrangements to have constructed seven sound-proof demonstration rooms, which will be ready in a very short while. The manager for this new Columbia department has not yet been selected, but will be announced next week.

VICTOR

A complete line of Victor products, from the smallest repair part to the biggest model of machine. Every shipment made promptly.

EDISON

Cylinder goods, machines and records; full stocks and immediate deliveries. A good popular-priced line for most any territory.

Louis Buehn Philadelphia

SUMMER ADVERTISING CAMPAIGN IN MILWAUKEE

Is Being Carried on with Great Success—The Satisfactory Crop Outlook Means Enormous Business in the Fall—Milwaukee System and Service Co. to Handle Edison Dictating Machines—New Columbia Agencies—Some Striking Displays—News of Month.

(Special to The Talking Machine World.)

MILWAUKEE, WIS., July 9.—Milwaukee talking machine men believe that the excellent crop outlook gives promise of a good future business, and everyone is looking for a good fall trade.

There probably has not been a summer when Milwaukee dealers have advertised so consistently as they are doing this season. Practically all the leading houses are running good-sized advertisements in the local papers at stated intervals, and the results which are being obtained have been entirely satisfactory. One of the houses which has been advertising especially strong is the J. B. Bradford Piano Co., featuring the Victor line, and officials of the company say that sales have held up remarkably well.

McGreal for Congress.

Lawrence A. McGreal, formerly Edison jobber in Milwaukee, and one of the former presidents of the National Association of Talking Machine Jobbers, has announced that he will be a candidate for Congress on the Democratic ticket from the Fifth Congressional District, comprising a portion of the city of Milwaukee. Mr. McGreal is now sheriff of Milwaukee County.

To Handle Edison Dictating Machines.

The Milwaukee System & Service Co. has been organized to succeed the Tisch-Hine Co., 450 Jackson street, representative of the Edison dictating machine, and will now act as distributor of this machine for the entire State of Wisconsin. Officers of the new company have been elected as follows: President, Julius Tisch; vice-president, William Finger; secretary and treasurer, A. B. Cooper. William Tisch is acting as manager.

L. C. Parker, enterprising manager of the Victor and piano departments at Gimbel Bros.' store, was the only talking machine man in this city who attended the annual convention of the National Association of Piano Merchants held in New York June 8, 9, 10 and 11. The Victor business at the Gimbel store during the month of June attained a new high mark for that month.

Takes the Victor Agency.

The Young Cash Store, at Hartford, Wis., has taken up the agency for Victor goods in that city. The store has arranged handsome new booths for the demonstration of the Victor machines and is meeting with much success in handling the line.

Paul A. Seeger, manager of the Victor department at the Edmund Gram Music House, is especially well pleased with the way the demand for the large Victrolas has been maintained thus far this season.

Enthusiastic Over Trade Outlook.

Officials of the Flanner-Hafsoos Piano House are enthusiastic over the manner in which the Edison disc machines are selling in Milwaukee. The house took on the line only recently, but it has met with a much larger business than it had anticipated. Charles H. Schefft & Sons, 849 Third street, carrying both the Victor and Edison goods, and C. Niss & Sons, 697 Third street, featuring the Edison goods, have been meeting with a brisk business.

William Idle Succeeds Hope.

William Idle, who has been assisting William A. Schmidt, manager of the Phonograph Co., of Milwaukee, in locating new Edison dealers about Wisconsin, has been made traveling wholesale representative of the Thomas A. Edison Co., Inc., in Wisconsin and upper Michigan, succeeding William P. Hope, who is now Edison jobber in Kansas City. Mr. Idle is now spending his vacation at his home in the East. Mr. Idle and Mr. Schmidt established eight new dealers on their recent trip through Northern Michigan.

New Columbia Agents.

A. G. Kunde, 615 Grand avenue, Columbia jobber and dealer, has established two new Columbia agencies in Milwaukee. Otto Hausmann, who conducts a retail business at 1208 Kinnickinnic avenue, has taken on the agency for the Columbia goods and is meeting with excellent success. Otto F. Leidel, who opened a new retail piano store in this city some time ago, is now featuring the Columbia machines and records and is meeting with a brisk business. Mr. Leidel has just moved into first floor quarters at 879 Third street, where he is arranging some attractive new booths. Mr. Kunde expects to be located in his handsome new store in the building which is being erected at his former location, 516 Grand avenue, by September 1. The new store will have seven demonstration rooms and will be one of the finest retail stores in Milwaukee.

Change of Name.

The name of the McGreal retail Victor store at

312 Grand avenue has been changed to the Backus Victrola Shop. The final organization of the Wisconsin Talking Machine Co., the jobber in this State for the Victrola line, will be completed within the near future, when officers will be elected and other details perfected.

Victrola for Steamship Minnesota.

The Gensch-Smith Co., 730 Grand avenue, recently sold a Victrola Style XIV. to the Crosby Transportation Co., for use on the company's lake vessel, "Minnesota," plying between Milwaukee and Buffalo. An order for \$50 worth of records accompanied the sale of the machine.

Striking Fourth of July Window.

J. H. Becker, Jr., manager of the Victor department of the Hoeffler Manufacturing Co., attracted attention to the Hoeffler windows by a novel Victor ante-July 4 display, bearing these placards: "Celebrate the Fourth of July with a Victrola;" "Fireworks Dangerous and Don't Last Long—A Victrola Keeps on Entertaining the Year Around;" "Spend a Safe and Sane Fourth—The Victrola Plays Patriotic Music." Other interesting window cards illuminated, showed photographs of Alma Gluck, John McCormack and other Victor stars, and called attention to the records by these artists. The attractive windows, arranged by Mr. Becker, have been a strong factor in bringing a big business to the Hoeffler company. Manager Becker says that trade during the month of June was better than that experienced during April and May.

Brieflets.

Roy J. Keith, of The Talking Machine Co., of Chicago, and U. P. Gibbs, representing The Rudolph Wurlitzer Co., recently called upon the Milwaukee trade.

THE EILERS TALKING MACHINE CO.

The Eilers Talking Machine Co., which was recently incorporated in Seattle, Wash., with a capital stock of \$25,000, is transacting a very excellent business. The new firm is composed of C. H. Hopper, president and treasurer; John W. Roberts, vice-president, and Edward P. Kelly, secretary and sales manager. They are all practical business men and have had a long experience in the talking machine field. The company is occupying spacious and well equipped quarters on the second floor of the Eilers building, and all concerned are most sanguine regarding the future of the talking machine business. The Victor, Edison and Columbia lines are handled.

EASY TO CRITICISE.

It is easy to sit in the sunshine
And talk to the man in the shade;
It is easy to float in a well-trimmed boat,
And point out the place to wade.
But once we pass into the shadows,
We murmur and fret and frown,
And our length from the bank we shout for plank,
Or throw up our hands and go down.

It is easy to sit in our carriage
And counsel the man on foot;
But get down and walk, you'll change your talk,
As you feel the peg in your boot.
It is easy to tell the toiler
How best he can carry his pack;
But no one can rate a burden's weight
Until it has been on his back.

—The Poster.

"ANALYZING THE HUMAN VOICE."

In connection with the article on "Analyzing the Human Voice," by Dr. Floyd S. Muckey, which was reprinted on page 14 in The Talking Machine World of last month by permission of the Scientific American, there were several cuts used, two of them showing a soprano solo and a tenor voice sounding vowels, as they appear on Edison phonograph records. Through an error this fact was omitted under the captions of these cuts, thus confusing them with the illustrations and data in Dr. Muckey's article.

Dr. Muckey desires it understood that the two cuts were unauthorized by him and were not a part of his original article. The extra cuts were inserted by The World merely for the purpose of adding to the trade interest in the article, and with no desire to discredit Dr. Muckey or his work, and we feel that this explanation, which we gladly make, is due him.

To Southern Dealers

If you want to send your orders where they will be
FILLED—

If you want prompt and accurate service—

If you wish to deal with a distributor who takes
PERSONAL interest in YOUR success—

If you want your orders to go where they will be
appreciated—

If you want—in short—SATISFACTION—

SEND YOUR ORDERS TO

Reynalds Music House

W. H. REYNALDS, Prop.

Victor Distributors

Edison Cylinder Jobbers

167 Dauphin Street

MOBILE, ALA.

The best-known trademark in the world

“The Victor talking machine’s design, ‘His Master’s Voice,’ has become a household word, and the quaint little fox terrier at attention before the horn is familiar to more Americans than any of the world’s great masterpieces.”—*Collier’s Weekly*.



The most valuable trademark in the world

Valuable to every Victor dealer—to the entire music trade.

It stands for all that is best in music. It is the mark of quality that leads the way to music trade success; that brings with it profit and prestige and insures continued prosperity.

"The future of our nationa



1. Kindergarten Games, Milwaukee, Wis.
2. Morris Dance, St. Cloud, Minn.
3. Music Appreciation, Fitchburg, Mass.
4. Folk Dancing, Weatherford, Tex.
5. Christmas Entertainment, Baltimore, Md.
6. High School hears Caruso, Temple, Tex.
7. "Study hard and the Victor will play," Seattle, Wash.
8. Highland Fling, Council Bluffs, Iowa.
9. Csardas, New York City.
10. I See You, Rochester, N. Y.
11. Calisthenics, Denver, Col.
12. Butterfly Dance, Philadelphia.
13. Klapdans, Allentown, Pa.
14. Children's Games, Spokane, Wash.
15. Calisthenics, Fort Worth, Tex.
16. The Motif, Emporia, Kan.
17. Virginia Reel, Camden, N. J.
18. Eleven Nationalities, Seattle, Wash.
19. Physical Culture, Dallas, Tex.
20. May Pole Dance, Port Huron, Mich.

Just a few of the 5,000
Victor in a great variety of
than 1200 cities.

And this means that the
life of all these children, and
the Victor idea right into the

This immense success of
only one of the big influences
greatest commercial success

Music rests with the schools"



Children who are using the
Victor in the schools of more

Victor is a part of the daily
life of these children are carrying
the Victor home.

"Victor in the schools" is
the Victor that has made the Victor the
center of the whole music industry.

21. Deaf girls watch teacher, Central Park, New York City.
22. Interpreting "Jewel Song" from Faust, Washington, D. C.
23. Classic Dance, Bloomington, Ill.
24. Listening Lesson, Chicago, Ill.
25. Calisthenics, Delaware, Ohio.
26. Elementary Class, Little Rock, Ark.
27. Opera Lecture, Athens, Tenn.
28. Wand Drill, Atlanta, Ga.
29. Melba Sings, Evanston, Ill.
30. Appreciation, Brooklyn, N. Y.
31. Field Day, Tacoma, Wash.
32. Deaf Mutes hearing the Victor, Mount Airy, Philadelphia.
33. Moccasin Dance, St. Paul, Minn.
34. Little Lady of Six in Folk-Dance, Cleveland, Ohio.
35. Wand Drill, Springfield, Mo.
36. Marching—School Dismissal, Portland, Me.
37. Toothbrush Drill, Providence, R. I.
38. During Recess, Stockton, Cal.
39. Oxdansen, Berkeley, Cal.
40. Kindergarten, Cedar Rapids, Iowa.



The greatest musical industry in the world

The center of music trade activity. The dominant factor in the prosperity of the music trade.

Its influence extends to every part of the world. Its products have brought success to music dealers everywhere.

The growth of the immense Victor plant is co-incident with the growth of Victor dealers. Every new addition has carried them from one success to another still greater—and the Victor factories and Victor business keep right on growing.

Factory extensions, costing more than \$1,500,000, are being added this spring and summer to the Victor plant as pictured above.

This is the Victor Company's answer to the demand for more Victors, Victrolas and Victor Records.

THE IMMACULATE SHOP AS A TRADE BOOSTER.

Have Your Store Clean to the Point of Spotlessness, Mr. Dealer, and Attract the Particular Folks—A Few Illustrations of How Much a Spic and Span Establishment Will Aid Its Owner in Acquiring the Most Exclusive Trade—Critical but Constructive Hints.

I do not mean to insinuate, Mr. Talker Man, that you are not careful as to the general appearance of your place of business; I am very sure you are. The point is this: Are you careful to the point of being what your employes may term finical? If not, I would suggest that you acquire the habit at once, for by so doing you will attract a class of trade which now passes you by on its way to the immaculate shop up the avenue.

The immaculate shop makes a specialty of cleanliness. From its show window to the most inconspicuous corner of its record racks you may search all day, if you like, and no fleck of dust or plague-spreading fly will reward your efforts. This place is clean!

The word "record" brings to mind an experience of the writer along the proper channels for narration at this time, so please bear with him as kindly as you can. He had occasion once, during his brief career as a talking machine salesman, to purchase fifty records for a finical woman. Her house, I will have you know, was famous for its antagonism toward dirt. The most bescrubbed cottage in Spotlestown had nothing on her abode, I assure you.

Well, to resume, he bought the records for her at a long-established and highly successful talking machine store in his home town, never glimpsing the storm clouds lifting themselves above his trade horizon. He delivered the order in due course, and was very much surprised to find in his morning mail a few days afterward, instead of the check he expected, a letter from Mrs. S. asking him to call and get his goods. Upon his arrival at her home, she informed him in very strenuous terms that she would not accept the filthy things, and, with more force than diplomacy, accused him of selling her a second-hand product. This accusation naturally made the writer rather sore, for he had spent the greater part of a day picking out the selections he thought would most tickle her fancy. Having done so, he felt that to be treated in this absurd fashion was unpardonable, and he told the lady so. By way of answer, she raised a record carton from among its fellows and blew sharply upon it. Like unto a sandstorm upon the Sahara was the result.

"Now, young man," exclaimed the outraged customer between coughs, "take these records back and bring me some that are clean!"

This experience was made possible simply through neglect on the part of the jobber in keeping his stock free from dust. It put the writer in bad with a good patron also, but at the same time it proved beneficial, viz., thereafter when he had an order to deliver he saw to it that the goods were clean. They had to pass the high standard set by Mrs. S., and that was going some.

Let us gaze into the show window a moment, Mr. Dealer. The general effect is very good. The display is well executed and correctly set up, but there prevails a certain lack of freshness. The snap and ginger which the window gave out to the passer-by when newly dressed has disappeared, and in its place has come an air of dowdiness. Milady is impressed with pretty things, but she demands them freshly and daintily served. When she goes tripping into the Cafe Dansant and orders her

lettuce sandwich and pot of tea, the lettuce must be crisp and the napery well laundered, or Louie is soundly scolded and made to try again. Thus it is with your show window, Mr. Dealer, for she will pass by your store on her way downtown some day, and if you would have her pause and admire, you must bedeck it in the style that will most attract her, which means that it must be immaculate as well as artistic.

Another thing that goes far toward making a good impression along the line of cleanliness is the careful dressing of employes. It is really rather disgusting to do business with a talker shop where the clerks are slovenly apparelled; where soiled collars, rusty footgear and dark finger nails are the rule. I am very glad to be able to vouch for the fact that this lack of attention to dress among talking machine employes is greatly in the minority, but it does exist, and therefore, is a menace to trade.

Even though this condition of inelegance may not be noticeable in your place of business, Mr.



Makes Specialty of Cleanliness.

Dealer, why not look the boys over when they come in to-morrow, and, if there is room for improvement, suggest, in a fatherly manner, that they take a few moments' more time each morning in the preparation of their toilets. There is absolutely no reason why they should take offense at this request when they understand what it will mean to you mutually to have the establishment immaculate.

Oh, by the way, while upon this subject it might be well to speak to them upon the theme of immaculate conversation. There is a tendency among young clerks to prove their manliness by indulging in remarks that are verging on the risqué. I have been in talker shops where I have listened to stories fit only for a barroom, and, very often, during the rendition of such a yarn there was a lady within hearing. Is not this very wrong? Does it not place the establishment where it is allowed to occur upon a low plane?

I do not mean to infer that these young raconteurs of the risqué are vicious citizens; far from it. They are entering the borderland of maturity, when all things blasé seem clever, and a heart-to-heart talk with their boss will give them just the proper impetus in the right direction, and if delivered at the psychological moment will correct this evil. Try it and see.

I received from a talking machine dealer the other day a beautiful booklet. From the standpoint of the author, the artist and the publisher it was a triumph, but from cover to cover it was decorated throughout with grimy finger marks. The hands that prepared that pamphlet for mailing

had not been on speaking terms with soap and water for "some considerable period," as Harry Lauder says it. Now, honestly, is it not lamentable that an artistic creation, upon which three skilled minds labored with infinite success, should be marred through the medium of a pair of dirty hands?

Are you sure, Mr. Dealer, that your literature is going out to your customers as clean and bright as it comes to you from the printer or the factory? I would look this matter up if I were you and satisfy yourself that your advertising is as clean as your shelves, your window, and the collars of your clerks.

I will end this little talk about immaculate things by telling you of how great value the talking machine has proven to the Chautauqua. The Chautauqua of which I speak has its home in Swarthmore, Pa., from which quaint town it sends out to the country at large 200 branches. Each branch gives, inside its spacious tent, clean and highly entertaining concerts, lectures by great men and band recitals. I was fortunate enough to be present last week at the Mount Holly, N. J., Chautauqua. It was Junior Chautauqua Day, and the youngsters of the town were gathered together under the wing of the superintendent and drilled in a little play entitled "In Mother Nature's Flower Garden." They all went through their many parts splendidly, due to the fact that the music supplied for the songs and dances was in perfect tempo and rendered most melodiously. Of course, this music was furnished by a talking machine. A clean instrument in a clean field. Let us see to it that the present standard is maintained.

HOWARD TAYLOR MIDDLETON.

"TALKER" MUSIC WHILE YOU WAIT.

How the Shoe Shining Parlors of Indianapolis Entertain Their Customers.

(Special to The Talking Machine World.)

INDIANAPOLIS, IND., July 9.—Shoe shining parlors in Indianapolis are equipped with talking machines, and while the energetic Greek boys shine and polish shoes the customers are entertained with the latest music of the day. Some of the better equipped parlors have talking machines of which no person would need to be ashamed, while others have the very small instruments. But whatever the size, the music is there. The Greek boys appear to enjoy this innovation as much as does the customer. In one instance one of the boys stopped work long enough to put on a new record and then he went back to work cleaning and shining shoes, singing and humming the tune being played on the machine.

SIGNS UP NEW EDISON DEALERS.

(Special to The Talking Machine World.)

St. Louis, Mo., July 6.—M. L. Reynolds, traveling salesman for the Silverstone Music Co., Edison disc jobber of this city, is signing up many new Edison dealers in southern Missouri and Arkansas. Among the new Edison dealers recently enrolled are the Hollenberg Music Co., Little Rock, Ark.; A. B. Carne, Pierce City, Mo.; the Benedict-Boyce Music Co., Galesburg, Ill.; McQueen Bros., Carrollton, Mo.; C. W. Hess, Butler, Mo.; Bush & Carne, Dyersburg, Tenn.; T. J. Evans, Pittsburg, Kan.; W. H. Moreland, Jr., Metropolis, Ill.; Holbrook, Carthage, Mo.; H. L. Hoover, Springfield, Mo.; J. W. Guisinger, Fayetteville, Ark.

BE WITH THE LIVE ONES!

Mr. W. V. D.—(Full name Western Victor Dealer) Let us help your Victor business by prompt and complete shipments. Why pay exorbitant freight rates from eastern points when we have a tremendous stock and are waiting to fill your orders? In our fortieth year of service. Write us today.



The Knight Campbell Music Co.

Exclusive Victor Distributors

DENVER, COLORADO



THE TRADE IN BOSTON AND NEW ENGLAND

JOHN H. WILSON, MANAGER, 324 WASHINGTON STREET, BOSTON, MASS.

(Special to The Talking Machine World.)

BOSTON, MASS., July 6.—The Salem conflagration continues to enlist the attention of the talking machine trade, for in that \$12,000,000 blaze there were a number of machines destroyed. One, the property of a resident of Lafayette street, was a Columbia "Grand" but for the most part they were the more inexpensive equipments. As far as known, the only talking machine house burned out was that of Jacob Schare, in Lafayette street, a Columbia dealer. Two concerns, distributors of Edison goods, who fortunately escaped, as they were not in the fire zone, were the Salem Talking Machine Co., at 87 Central street, and W. W. Ballard, of 175 Essex street. Both houses had a number of machines out in the burned district, however.

One of the Heroes of the Fire.

One of the heroes of the fire was Norman Mason, wholesale man for the Columbia Co., who happened to be near the scene of the fire just as the alarm was sounded. He was only a few blocks away and, seeing the smoke, rushed to the immediate vicinity and with a group of others was instrumental in carrying or leading several women and children to places of safety. Mr. Mason remained on the scene for nearly six hours, and some of the scenes he witnessed, he says, it will take a long time to forget.

Business Is Normal.

Summer business in the talking machine trade has been about normal, and most of the orders now come from the country or seashore homes of city people. Some of the houses report a good call from summer camps, some of them camps for boys or girls, of which there are many in Maine, and others of a more private character, family camps one might call them. As this letter is being written many of the local managers are leaving for the Atlantic City convention and some of the delegates are looking for a busy time, and all of them to a merry one. As most of them have been to Atlantic City before they know just what that resort has to offer.

Making Rapid Progress in Building.

Work on the changes in the building occupied by the Columbia Graphophone Co. continues to make rapid headway, and it will be only a few weeks before the Avery street side will be completed. Large plate glass windows will make the long line of demonstration booths among the most attractive in the city, and the advantages for advertising will be unsurpassed. As the outside be-

gins to assume more normal conditions, similarly is the inside of the Columbia quarters taking on a new dress, and Manager Erisman will be all ready for the fall business, which promises to set in unusually early this season.

Looking Forward to Vacations.

The camp crowd at the Eastern Talking Machine Co. is looking eagerly forward to their vacations at Southport, Me., where "Tisours" is always ready to welcome guests, especially as the boys take enough of good things down with them to make camp life quite bearable. Billy Fitzgerald and Jerry Spillane will be the first to go, and Hark Reed and Ed Welch will follow a fortnight later. So through August there will be something doing all the time, especially as the boys are planning to charter a motor boat.

Chamberlain's Western Trip.

A. W. Chamberlain, who lately established himself in Boylston street, has been on a tour through the West, taken in the interests of business. Mr. Chamberlain has invented a talking machine device which promises to be a favorite with the trade. He and his friend Gately, likewise widely known in the trade, have been taking week-end trips up to New Found Lake, N. H., where Mr. Chamberlain has a cottage.

Handsome Fourth of July Window.

The window of the C. C. Harvey Co. contained a handsome display for the Fourth of July holiday, and in the arrangement of red, white and blue the Victrolas played an important part. These had been carefully arranged by Francis T. White, manager of the Victor department, and as the window was brilliantly illuminated at evening many persons stopped to enjoy the display.

Vacations at Henry F. Miller & Co.

Vacations are now in order at the Henry F. Miller & Co. Victor department, and the first to go away is Frank H. Jenkins, who has gone over to New York. Percy Baker starts the last two weeks in August. Manager Warren Batchelder is not planning to go away, but will spend his vacation at home, as he is expecting to entertain visitors.

Rearrangement at Steinert's.

Manager Royer, of the Arch street Victor quarters of the M. Steinert & Sons Co., has undertaken quite an extensive rearrangement of the Victor department, and on the ground floor new demonstration booths are being installed, which will add considerably to the facilities for caring for customers. When the changes are completed there will be

four new good-sized booths leading off an aisle which can be kept quite apart from the main room. At the rear there will be a small chute to the floor above so that all desired records can be sent down from the stock room without the salesman going out to the front of the store at all. On the second floor all the offices will be changed about, and Manager Royer's private office will be near the door rather than at the other end of the floor, as is now the case.

In Charge of Lowell Branch.

Manager Royer announces that L. P. Comet, who formerly was in charge of the Victor department of the Steinert's New Haven, Conn., store, has been placed in charge of the company's Lowell establishment, and he already has entered upon his new duties. Mr. Comet knows the talking machine business thoroughly, and the Lowell store should forge ahead under his supervision.

The First Batch of Vacationists.

The first four persons to leave the Eastern Talking Machine Co. for their summer vacations are Miss Crowley, of the memorandum department; Miss Sheehan, of the office; William Doherty, one of the shippers, and the errand boy. One of the additions to the staff of the Eastern is Miss Held, formerly with the Kahn talking machine house in the Arcade.

Attended the Convention.

Manager Royer, of the Victor department of the Steinert Co., and A. M. Hume, of the Hume and Jewett piano companies attended the Atlantic City jobbers' convention. They will later visit the Victor laboratories at Camden.

Pardee-Ellenberger New Quarters.

Manager Silliman, of the Boston quarters of the Pardee-Ellenberger Co., can now rest easy nights, as most of the work incident to removal to the new quarters in Oliver street is finished. When mention was made last month of the change there were a number of small things to be done before the house was permanently settled, but now that everything is just as it should be, one cannot but marvel at the change that has come over this well-known distributing agency, and never before in this city were the Edison goods shown under just such advantageous conditions as now. The main showroom with its handsome carpet and the various styles of Edison disc machines placed conveniently about the room show up unusually well, especially when the inverted lighting system is turned on.

WE FORMALLY announce the opening of our new headquarters at 26 Oliver Street, Boston, Mass., where we have secured greatly increased floor space and have installed the most modern facilities for the quick handling of Edison goods.

Special attention has been given to the shipping department, which is of unusually large size, where will be maintained a most complete stock of Edison Disc and Cylinder Machines and Records.

You are invited to call and inspect our new building.



The
Pardee-Ellenberger Co.
26 Oliver Street, BOSTON, MASS.

Southern New England Offices at
NEW HAVEN, CONN.

With the big demand for Edison Disc Phonographs, you should transact a big Summer business, to say nothing of the Fall and the years to come. Want us to tell you how?

THE TRADE IN BOSTON AND NEW ENGLAND

JOHN H. WILSON, MANAGER, 324 WASHINGTON STREET, BOSTON, MASS.

Going to Make a Record.

Billy Fitzgerald, so his friends say, is plugging for all he is worth as the new head of the wholesale department of the Eastern Talking Machine Co., and he is destined to make a record both for himself and for the company.

Summering at Nantasket.

Harland R. Skelton, of the Edison Co., is spending the summer at Nantasket, where he and his family have a cottage.

Rusticating in Maine.

Guy R. Coner, of the Pardee-Ellenberger Co., left a few days ago for his annual vacation in Maine; L. H. Ripley is going away this week, and Robert C. Peck will follow soon after.

Reports Busy Times in New Haven.

W. O. Pardee, of the Pardee-Ellenberger Co., of New Haven, when he was in town this week reported that business down his way was very fair and there was more activity noticed than in some time. Several of the concerns in his city, he said, are canvassing among the hotels, and with considerable success, and this has led to looking into the shore resort proposition, which promises to be a fruitful field. Mr. Pardee instanced several cases where small orchestras were being supplanted by Edison disc machines, the managers having become convinced that these equipments could furnish greater variety than the players because of the vocal as well as instrumental concerts they were able to provide. In such cases where the hotel managers have had any trouble with their musicians there has been prompt decision to resort to these Edison machines, and everywhere that they are in use they are giving much satisfaction, besides furnishing a splendid medium of advertising among the guests.

Ellenberger Motored from New Haven.

H. L. Ellenberger, of the Pardee-Ellenberger Co., was in town with his family a few days ago, making his headquarters while here with Manager Silliman, the Boston manager of the company. Mr. Ellenberger and his family motored up from New Haven in their new car, which ran very smoothly. Mr. Ellenberger does not get over to Boston very often, and therefore was doubly welcome.

Winkelman at Atlantic City.

Henry Winkelman, manager of the Victor department of the Oliver Ditson Co., was one of those who took a few days off from business to go to the Atlantic City convention last week. In August Mr. Winkelman will go with his family to Swan's Pond, Me., where they have summered for several seasons.

HASSETT BUYS PEABODY STORE.

(Special to The Talking Machine World.)

PORTSMOUTH, N. H., July 6.—Fred W. Peabody has disposed of his store in this city to Joseph N. Hassett, who for a number of years was manager of Mr. Peabody's interests. Mr. Peabody was able to build up a large business in talking machines in this city, and Mr. Hassett is not only perfectly familiar with the business but has a host of friends who are wishing him all kinds of good luck in his new undertaking. The store is centrally located and Mr. Hassett should be able to push even further a business so well established.

Enthusiasm is the white heat which fuses all a man's business qualities—ability, initiative, knowledge, tact, industry and the rest—into one effective whole.

TALKING MACHINE JOBBERS WHO ADVERTISE IN THE WORLD ARE LIVE ONES, TRY THEM!

Dignity is powerful. Familiarity weakens your cause.

AN ATTRACTIVE SUMMER WINDOW

Is That Recently Arranged and Brought to Public Notice by the Grafonola Parlors of Boston—Has Been Highly Commended.

(Special to The Talking Machine World.)

BOSTON, MASS., July 6.—This city has long been known as the home of unusual window displays in all lines of mercantile life, and in this well-deserved praise the talking machine trade is entitled

even in the picture. As a summer scene this window embodies every detail that should insure its sales value, and the many machine and record sales closed as a direct result of the display were certainly warranted by its originality.

A BIRD'S-EYE VIEW.

Took a bird's-eye view to-day, along and over the whole glad way that reaches out across the year, and there is nothing we need fear.

The way has been a little rough, but you've kept

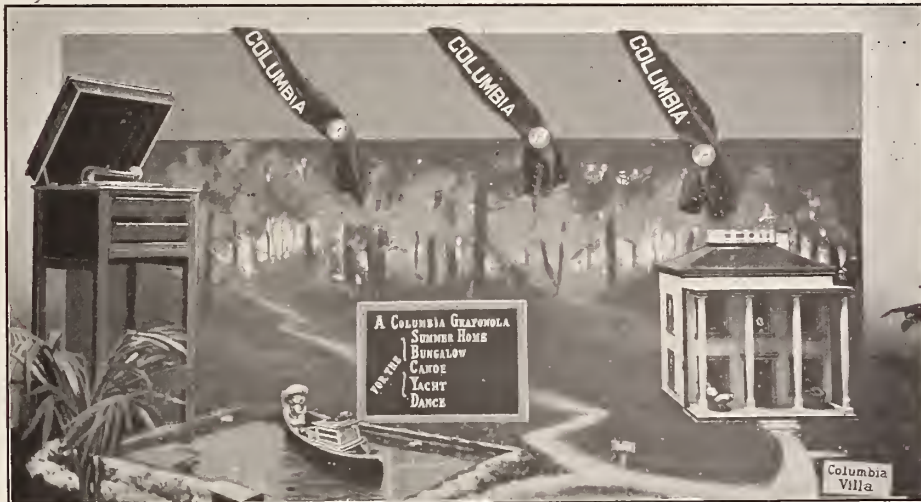

Grafonola Parlor's Seasonable Window Display.

to a good-sized share. As a matter of fact, the various members of the talking machine trade have produced timely and attractive displays throughout the year that have won the praise and admiration of many merchants in other fields, who expressed regret that their products did not adapt themselves so favorably to artistic display and arrangement.

An excellent example of this progressiveness of the local trade is shown in the window herewith, which was designed and arranged by the Grafonola Parlor, the successful Columbia representative. The timeliness and value of this display as a magnet for summer trade is beyond doubt, while the detailed perfection of the display is evident

going—that's the stuff—and haven't brought yourself to think that everything is on the "blink." That's right—and now stay on the ground, no matter who may come around and whisper loudly in your ear, that this will be one awful year. Let 'em whisper, then forget it, never for a moment let it hinder you from going on, nor hide from you the unclouded dawn of that glad era—overdue—yet coming sure for us and you. Even now we're just that near it lots of folks have caught the spirit, and are pushing back the gloom that might choke off the coming boom. But there isn't any danger, pass the word to friend and stranger; tell 'em in this bird's-eye view nothing but the sky looks blue.

MANY kinds of needles have been introduced to the trade recently, made of many materials, all launched with a view of improving the "tone" of the talking machine but none "make good" except to prove the superiority and reliability of the renowned steel needles made by

W. H. Bagshaw
LOWELL, MASS.

Our sales are constantly growing, for the steel needle as we make it is the true, scientific factor of tone reproduction. Bagshaw-made needles are BEST—remember this!

STRINGS FOR ALL MUSICAL INSTRUMENTS

INCLUDING THE CELEBRATED DURRO STRINGS KNOWN ALL OVER THE WORLD
 A MOST DESIRABLE ADDITION TO YOUR BUSINESS
 OVER 250% PROFIT. REQUIRES NO SALESMAN

Our Silent Salesman String Show Case No. 6 Absolutely *FREE!*

Takes up very little room. Each String is packed in separate envelope, plainly marked, and has its separate compartment.

Any child can sell Strings from this Case, without errors. An added attraction to any store.



No. 6. The Size of the Case is 12 1/2 x 16 1/4, and 4 inches deep.

Show Case Contains the Following Assortment of Strings for All Instruments:

	Cost.	Sell.	Total selling price.		Cost.	Sell.	Total selling price.
15 Durro E	\$1.25	\$0.25 each.	\$3.75	12 Imperial Mandolin E..	\$0.12	\$0.05 each.	\$0.60
10 " A.....	.84	.25 "	2.50	12 " " A..	.12	.05 "	.60
6 " D.....	.60	.25 "	1.50	12 " " D..	.22	.10 "	1.20
6 " G.....	.38	.25 "	1.50	12 " " G..	.28	.10 "	1.20
15 Blue Ribbon E.....	\$0.68	\$0.10 each.	\$1.50	12 Imperial Banjo 1st....	\$0.12	\$0.05 each.	\$0.60
10 " " A.....	.45	.10 "	1.00	12 " " 2d.....	.12	.05 "	.60
6 " " D.....	.35	.10 "	.60	12 " " 3d.....	.12	.05 "	.60
6 " " G.....	.15	.10 "	.60	12 " " 5th....	.12	.05 "	.60
15 Durro E Silk.....	\$1.12	\$0.25 each.	\$3.75	12 " " 4th....	.25	.10 "	1.20
15 Durro E Silk Cord....	1.00	.25 each.	3.75	12 Imperial Guitar E....	\$0.12	\$0.05 each.	\$0.60
12 Imperial Violin E.....	\$0.10	\$0.05 each.	\$0.60	12 " " B....	.12	.05 "	.60
12 " " A.....	.10	.05 "	.60	12 " " G Spun	.22	.10 "	1.20
12 " " D.....	.10	.05 "	.60	12 " " D....	.28	.10 "	1.20
12 " " G.....	.20	.10 "	1.20	12 " " A....	.35	.10 "	1.20
				12 " " E 6th.	.45	.10 "	1.20

Contents of case at net WHOLESALE price cost \$10.33
 SELLING PRICE - - - - - \$36.65
 Leaving you a net profit of - - - - - \$26.32
 AND THIS HANDSOME GLASS SHOW CASE FREE!

BUEGELEISEN & JACOBSON
 ORIGINATORS, NOT IMITATORS

113-115 UNIVERSITY PLACE

NEW YORK



Eighth Annual Convention

of the

National Association of Talking Machine Jobbers

Atlantic City, N. J., July 6 and 7, 1914

(Special to The Talking Machine World.)

ATLANTIC CITY, N. J., July 7.—In the matter of full attendance and harmony the eighth annual convention of the National Association of Talking Machine Jobbers' which was held at the Chalfonte Hotel yesterday will stand forth in the association's history as the most successful annual session ever held by the body. In regard to the attendance, particularly, the success of the meeting was not accidental. The officers of the association, L. C. Wiswell, the chairman, and other members of the arrangements committee, and Louis F. Geissler, general manager of the Victor Talking Machine Co., by means of his recent letter to the jobbers urging them to attend the session, all put forth strenuous efforts to make the gathering a notable

ishing condition of the association at the present time is doubly pleasing in view of the fact that conditions have changed wonderfully during the past year in the talking machine industry.

"The Edison disc jobbers have formed an association which should be of immense value to those handling the Edison disc line, and this has created a condition in our membership which should tend towards bettering our association, inasmuch as our association now virtually consists of Victor jobbers, this feature bringing us much closer to our source of supply, as is shown by the tone of General Manager Louis F. Geissler's letter to the jobbing trade, under date of June 20, inviting the heads of Victor jobbing firms to be present at our eighth annual convention.

"Your various committees have been received by the Victor officials during the past year with every consideration and every possible attention has been given our various requests.

"Financially, the association is stronger than ever and in its present form much can be expected in betterments during the coming year.

"During my term I considered it advisable to appoint an advisory committee to consist of all ex-presidents still actively engaged in the jobbing of talking machines, the junior retiring president to be chairman, this committee to be subject to call of the executive committee for any advice and work deemed necessary by them. I would recommend that our by-laws be amended to make this committee a permanent one.

"I would further recommend that our by-laws be changed at this meeting in order that our membership be strengthened. For instance, we have a number of jobbing firms who are jobbers in two or more cities yet who are members of the association only at one point. I believe it would be wise to amend our by-laws to read that jobbing firms having two or more jobbing branches be admitted to membership at the regular dues of \$15 per year at the home office, and \$5 per year for each branch house.

President Roush, in his report before the executive committee at its final meeting on Sunday, also suggested that the by-laws of the association be amended as outlined, and the amendments were adopted in the meeting unanimously.

Secretary Whitsit next presented his annual report as follows:

Secretary Whitsit's Report.

"The membership of the N. A. T. M. J. September 15, 1913, was 108 members, composed of fifty-nine jobbers of Victor goods, twenty-five jobbers who handle both Edison and Victor, and twenty-four jobbers who handle only the Edison product. Since that time we have had thirteen resignations of jobbers who were handling Edison goods only, and your executive committee dropped from mem-



J. C. Roush, Retiring President.

one. The result was that seventy-four of the eighty-five jobbing houses, now members of the association, answered to the roll call in the meeting and representatives of two other houses reached convention headquarters on the day following, making the wonderful total of seventy-six out of eighty-five members represented, or 90 per cent. It is, indeed, rare that in any association convention such a record is made.

Following the roll call, reading of minutes and other preliminary business, Joseph C. Roush, president of the association presented his report for the year, which was as follows:

President Roush's Report.

"Since taking office, September 15, 1913, I have deemed it necessary to call two meetings of the executive committee to discuss matters of importance to the talking machine trade, the first meeting being held in Chicago, September 21, 1913, and the second at Philadelphia, February 15, 1914. I am happy to say that at each meeting the entire executive board was present. Many matters of interest were discussed and Secretary Whitsit will give complete details in his annual report.

"The work accomplished during the year has been very gratifying to your officers, and the flour-



Perry B. Whitsit, Retiring Secretary.

bership nine concerns for non-payment of dues. There have been four jobbers who have discontinued business, therefore have been dropped from membership in the association, making a total loss of twenty-six members in the association. We have had two new members, which makes the association now stand at a total of eighty-four members.

"There has been collected and turned over to the treasurer through this office the sum of \$1,380.

"The executive committee since the seventh convention has had two meetings, one at Chicago, September 21, 1913, and one at Philadelphia, February 15, 1914.

"Every member of the executive committee was present at the Chicago meeting, as well as a number of other members of the association. A number of subjects of interest to the association were acted upon at this time and a committee was appointed to confer with the Victor Co. in regard to them.

"The following resolution was unanimously adopted at that time:

"Resolved, That an advisory committee be created, this committee to be made up of the ex-presidents of the N. A. T. M. J. actively engaged in the wholesale distributing of talking machines

(Continued on page 28.)

Officers of the National Talking Machine Jobbers' Association for 1914-1915.

President—George E. Mickel, Nebraska Cycle Co., Omaha, Neb.

Vice President—E. F. Taft, Eastern Talking Machine Co., Boston, Mass.

Secretary—E. C. Rauth, Koerber-Brenner Music Co., St. Louis, Mo.

Treasurer—W. H. Reynolds, Reynolds Music Co., Mobile, Ala.

"In closing, on behalf of your retiring officers, executive committee, and myself, I wish to thank each and every member for the courtesy and support given your officers and executive committee during their term of office. We also wish to thank you for your promptness in answering various communications which were very important to our association."

Next Convention City San Francisco



A View of Conventionists Taken in Front of the Chalfonte After the Day's Session. The Satisfied Expression Upon Their Faces Shows That the Atlantic City Breezes Blew Dull Care Away.

who are members of the association in good standing, the duty of this committee being to confer with the executive committee upon matters of moment, the retired president each year to become automatically chairman of this committee.'

"At the meeting held in Philadelphia February 15 all members of the executive committee were present, as well as J. N. Blackman, chairman of the advisory committee, and a number of other members of the association."

The Treasurer's Report.

The report of the treasurer, W. H. Reynolds, was next presented and showed that the finances of the association were in excellent shape, with a substantial balance on hand. Every active member of the association had paid up dues to October 1, 1914, an excellent record.

Topics Discussed.

A number of discussions of great importance to Victor jobbers and the trade in general were considered, among them being a discussion of the desirability of charging interest on all instalment sales. It was the consensus of opinion that the charging of interest was fast becoming an actual necessity and it is probable that the manufacturers will be asked to arrange their contracts to provide for interest charges.

General Improvement in Stocks.

Reports from members indicated that there had been a general improvement in the stocks of the Victor jobbers throughout the country, though there was still a decided shortage in certain of the more popular records despite the tremendous increase in the record output of the Victor Co. The transfer bureau, operated at heavy expense by the bureau, has proved a most valuable aid to the jobbers in keeping their stocks of machines and records balanced and in good shape by reducing much of the surplus.

Report of Traffic Committee.

One of the interesting committee reports filed at the meeting was that of the traffic committee, of which L. C. Wiswell is chairman, and which was as follows:

"It would seem that the hand of fate was especially considerate of the talking machine industry during the past year, for so far as your committee can learn, no changes in the rates of transportation or classification have been made, other than the proposed 5 per cent. horizontal increase in the freight rates on the territory east of the Mississippi and north of the Potomac and Ohio rivers, which proposed advance was suspended by the Interstate Commerce Commission in November last, and is still held in abeyance by them, nor are any under contemplation by the various classification committees, in fact, the condition is one of which we should congratulate ourselves.

"Your committee received from the entire membership of the association only two complaints during the past year, one of which concerned the seeming overcharge on the transporting of some record cabinets, and the other was in relation to delays to shipments en route from the factory to destination. Your committee in each instance gave the matters careful and immediate attention.

"Your committee has noted with keen interest the hearings which were held by the Interstate Commerce Commission, relative to the proposed 5 per cent. horizontal increase in freight rates for the Eastern roads, and took occasion at the meeting of the executive committee, which was held at Philadelphia on February 15, to inquire of the executive committee as to their position relative to this proposed increase and requested instructions. The executive committee's opinion was that the association take a stand in the premises affirmatively.

"It is the desire of the committee to be of genuine assistance to the entire association membership and any communications addressed to the committee with reference to delays in shipments, errors in freight expense bills, etc., will be given prompt and careful attention."

Mr. Wiswell and Associates Thanked.

The arrangement committee, of which L. C. Wiswell was chairman, also presented its report, but the success of the committee's work was too evident to make a written report necessary. The as-

CONVENTION OF THE NATIONAL ASSOCIATION OF TALKING MACHINE JOBBERS—(Continued from page 28).

sociation tendered a rising vote of thanks to Mr. Wiswell and his associates for their earnest efforts in making the present convention a memorable one.

New Officers Elected.

Next in order came the annual election, and as a result the following gentlemen will preside over the destinies of the association for the ensuing twelve months:

President, George E. Mickel, Omaha, Neb.

Vice-president, E. F. Taft, Boston, Mass.

Secretary, E. C. Rauth, St. Louis, Mo.

Treasurer, W. H. Reynolds, Mobile, Ala.

Executive committee: O. K. Houck, R. H. Morris, Parham Werlein, C. J. Schmelzer and W. O. Crew.

Following the election the thanks of the association was tendered to the retiring officers for their efficient service.

E. R. Johnson Elected as Honorary Member.

In appreciation of the efforts of the Victor Co. in furthering the work of the association in many directions, the association, by unanimous vote, elected Eldridge R. Johnson, president of the Vic-

Oliver Jones Sends Greetings.

While the meeting was in progress a telegram dated Albany, N. Y., was received from Oliver Jones, formerly credit manager for the Victor Co., and now in the real estate business, expressing his



George E. Mickel, President.

regret at being unable to be present at the convention and sending his best wishes to the jobbers. The association then adopted a resolution testifying to the high esteem in which Mr. Jones was held by the jobbers, with best wishes for his success.

One Continuous Session a Success.

The announced plan of transacting the entire business to come before the convention in one continuous session was an unqualified success. An elaborate buffet luncheon was served in the meeting to preclude any possibility of the members scattering, and there was absolutely no lost motion from the time the meeting was called to order at 9.30 a. m. until it adjourned at 3.30 p. m. The result was that the members left the meeting free



E. F. Taft, Vice-President.

to enjoy the elaborate program of entertainment provided by both the association and the Victor Co.

Ladies Entertained.

While the jobbers were in session the ladies in attendance at the convention were taken in automobiles to the Atlantic City Country Club, several miles from the hotel, where they were entertained at luncheon. After a rest at the club the party was driven back to convention headquarters by a cir-

cuitous route, which enabled the ladies to observe the various points of interest in and near the city.

Those Present.

Those present were W. D. Andrews, Syracuse, N. Y., W. D. Andrews, Mrs. E. C. Babcock, Miss Rhea McEvers; W. D. Andrews, Buffalo, N. Y., C. N. Andrews, Mrs. C. N. Andrews; American Talking Machine Co., Brooklyn, N. Y., R. H. Morris, Wm. Barker; The Aeolian Co., New York, Miss Ruby Spaulding; Andrews Music House, Bangor, Me., M. H. Andrews, W. G. Jordan; Blackman Talking Machine Co., New York, J. Newcomb Blackman, Mrs. J. Newcomb Blackman; Emanuel Blout, New York, Mr. and Mrs. Emanuel Blout, Misses Jeanette and Mildred Blout; Louis Buehn, Philadelphia, Pa.; W. H. Buescher & Sons Co., Cleveland, O., Mr. and Mrs. W. H. Buescher, A. H. Buescher, Mr. and Mrs. J. G. Card, Miss E. Volk, Mr. and Mrs. MacCall; C. Bruno & Sons Co., New York, Chas. F. Bruno, E. G. Evans; Cressey & Allen, Portland, Me., Frank C. Allen, Louis W. Fickett; the Corley Co., Richmond, Va., F. W. Corley, Fred R. Kesney, J. W. Greenor;



E. C. Rauth, Secretary.

Cohen & Hughes, Baltimore, Md., Mr. and Mrs. Cohen, E. Greensfelder; I. Davega, Jr., New York, Mr. and Mrs. I. Davega; C. H. Ditson & Co., New York, Paul Carlson; E. F. Droop & Sons Co., Washington, D. C., Mr. and Mrs. C. L. Houser, Miss Jones, Carl A. Droop, W. C. Roberts; W. J. Dyer & Bro., St. Paul, Minn., G. A. Mairs; Oliver Ditson Co., Boston, Mass., H. A. Winkelman; Elmira Arms Co., Elmira, N. Y., W. O. Crew; Eclipse Musical Co., Cleveland, O., T. H. Towell; Eastern Talking Machine Co., Boston, Mass., E. F. Taft; E. F. Eisenbrandt & Sons, Baltimore, Md., C. H. Eisenbrandt; Elyea-Austell Co., Atlanta, Ga., Mr. and Mrs. E. N. Upshaw; Finch & Hahn, Albany, N. Y., Mr. Finch, Mr. Young; Florida Talking Machine Co., Jacksonville, Fla., W. N. Dunham; W. F. Frederick Piano Co., Altoona, Pa., French Nestor, W. F. Frederick; J. B. Greenhut Co., New York, Mr. and Mrs. N. Goldfinger; Grinnell Bros., Detroit, Mich., Mr. and Mrs. H. Rupp, Mr. and Mrs. I. L. Grinnell, Miss Grinnell; Thos. Goggan & Bros., San Antonio, Tex., Fernando de Arredondo; C. J. Heppe & Son, Philadelphia, Pa., H. E. Ziegler, W. J. Elwell, F. J. Heppe; O. K. Houck Piano Co., Memphis, Tenn., O. K. Houck; O. K. Houck Piano Co., Little Rock, Ark., J. F. Houck; O. K. Houck Piano Co., Nashville, Tenn., Olney Davies; A. Hospe Co., Omaha, Neb., A. Hospe; Charles Jacob, New York; J. W. Jenkins' Sons Music Co., Kansas City, Mo., Burton J. Pierce; Knight-Campbell Music Co., Denver, Col., Col. R. H. Arbenz;

(Continued on page 30.)



W. H. Reynolds, Treasurer.

tor Co., to honorary membership in the organization.

At the present time only eight jobbers of the Victor goods are not members of the association and of the present membership of 85 only two concerns are not exclusive Victor jobbers.

During the course of the meeting numerous inner trade problems of importance to Victor jobbers were taken up for discussion and action and were referred to the incoming executive committee for what final action might be considered necessary.

Next Convention in San Francisco.

At the close of the session invitations from a number of cities were read and it was decided to hold the next annual convention of the association in San Francisco at a time approximating that fixed by the National Association of Piano Merchants for its 1915 meeting, owing to the fact that a number of the jobbers are also piano dealers and members of the merchants' association.

The choice of San Francisco as the next meeting place was made largely as a result of the efforts of L. S. Sherman, head of the prominent Pacific Coast music house, of Sherman, Clay & Co., who made a trip to the convention for the special purpose of securing the next convention of the association for his home city. Mr. Sherman was armed with a letter of invitation from the Hon. James Rolph, Jr., Mayor of San Francisco, and also a letter from Chas. P. Moore, president of the Panama-Pacific International Exposition.

CONVENTION OF THE NATIONAL ASSOCIATION OF TALKING MACHINE JOBBERS—(Continued from page 29).

Koerber-Brenner Music Co., St. Louis, Mo., E. C. Rauth; Landay Bros., New York, James B. Landay, Max Landay; Frederick Loeser & Co., Brooklyn, N. Y., Mr. and Mrs. E. Paul Hamilton; C. C. Mellor Co., Pittsburgh, Pa., J. Fisher, W. C. Dierks;

& Co., San Francisco, A. G. McCarthy, L. S. Sherman, C. S. Ruggles; Sanger Bros., Dallas, Tex., Elihu A. Sanger, Lester Burchfield; Benj. Switky, New York, B. Switky, Geo. W. Morgan, Mr. and Mrs. J. H. Dodin, S. Semels; Talking Machine

ton, Wilson Avenue Talking Machine Co.; Mr. and Mrs. D. W. Moor, Miss A. King, Standard Gramophone Appliance Co.; Clement Beecroft, H. C. Niall, Geo. A. Long Cabinet Co.; Harry Chapin Plummer; J. T. Edling, Velvatone Wood Needle



Some of Those Who Attended the Convention Snapped in Front of Hotel Chalfonte—Photo by Prince.

Neal, Clark & Neal Co., Buffalo, N. Y., B. E. Neal, O. L. Neal; New York Talking Machine Co., New York, Mr. and Mrs. A. D. Geissler, Nebraska Cycle Co., Omaha, Neb., Geo. E. Mickel; Price Talking Machine Co., Newark, N. J., Mr. and Mrs. Price; Silas E. Pearsall Co., New York, Chas. Bobzin; Putnam-Page Co., Peoria, Ill., Fred H. Putnam; Pennsylvania Phonograph Co., Philadelphia, Pa., Mr. and Mrs. John B. Miller, Mr. and Mrs. H. F. Miller, Mr. and Mrs. P. W. Barnhill, Mr. Cope; Reynalds Music Co., Mobile, Ala., W. H. Reynalds; Robert C. Rogers Co., Washington, D. C., Robert Rogers, Mrs. J. T. O'Keefe, Miss G. F. Golden; Standard Talking Machine Co., Pittsburgh, Pa., C. A. Bruce, A. G. Higgins, J. C. Roush; Schmelzer Arms Co., Kansas City, Mo., C. J. Schmelzer, A. A. Trostler; Stewart Talking Machine Co., Indianapolis, A. M. Stewart, Geo. E. Stewart; Sherman, Clay

Co., Birmingham, Ala., Mr. Williams and daughters; Talking Machine Co., Austin, Tex., W. E. Parker; Talking Machine Co., Philadelphia, H. A. Ellis; the Rudolph Wurlitzer Co., Chicago, F. A. Siemon, E. H. Uhl; Perry B. Whitsit Co., Columbus, O., Perry B. Whitsit; the Rudolph Wurlitzer Co., Cincinnati, O., J. H. Dietrich; Whitney-Currier Co., Toledo, O., J. G. Parmenter; W. A. Weymann's Son, Philadelphia, Pa., Mr. and Mrs. A. C. Weymann, Mr. and Mrs. H. W. Weymann, Mr. and Mrs. Wm. A. Weymann, Mr. and Mrs. Geo. Huver; the W. G. Walz Co., El Paso, Tex., G. G. Neville; John Wanamaker, New York, Mr. and Mrs. Gerson; Lyon & Healy, Chicago, L. C. Wiswell, M. A. Healy, J. F. Bowers, G. E. Meagher; Philip Werlein, Ltd., New Orleans, P. Werlein.

Others present at the convention festivities were Jos. Fink, Fink Talking Machine Co.; A. C. Fen-

Co.; E. H. Lansing and wife, Boston; M. A. Cappel, Herzog Art Furn. Co., Saginaw, Mich.; M. Mazur Mazur Piano Co., Baltimore; Chas. F. Johnson, Pooley Cabinet Co., Philadelphia; Edw. G. Schloss, E. Schloss & Co., New York; Mr. and Mrs. Max Strasburg, Mr. and Mrs. W. D. Trump, the Max Strasburg Co., Detroit; Wm. A. Condon, Willard V. Cook, Pathscope, New York; Geo. P. Troyer, J. R. Jones, National Publishing Co., New York; Wm. Reiser, Stewart & Co., Baltimore; J. B. Ogden, Lynchburg, Va.; Mr. and Mrs. S. O. Wade, Wade & Wade, Chicago; H. A. Dalley, Geo. W. Smith & Co., Philadelphia; S. Semels, L. Bamberger & Co., Newark, N. J.; B. B. Wilson, Talking Machine World; R. Montalvo, Jr., New Brunswick, N. J.; Milton Isaacs, New York; M. B. Clausen, Masterphone Corporation, New York, and George E. Bates, New York Album & Card Co.

Motion Picture Views of Victor Co.'s Plant.

Impressive Exhibition of the Process of Manufacture of Victrolas and Records From the Lumber Yard to the Shipping Platform, Given in Atlantic City During Convention—C. G. Child Discusses Recording Problems—Mrs. Frances E. Clark Gives Illustrated Lecture on Progress of Educational Campaign.

(Special to The Talking Machine World.)

ATLANTIC CITY, N. J., July 8.—Never before in the talking machine trade and probably not in any industrial field has the process of manufacture of an article been set forth so completely and in such detail as was the making of Victor talking machines and records when motion picture views of each of the departments of the factory from the lumber yards to the shipping platform were flashed upon the screen at the Apollo Theater yesterday for the benefit of those attending the convention of the National Association of Talking Machine Jobbers.

The pictures required three weeks of constant work on the part of the operators and much careful thought and effort on the part of the factory officials for their production, and although the jobbers had learned through indirect channels that the films were of an elaborate character, they were not prepared for the magnificent and impressive exhibition that was offered to them.

Beginning with the immense lumber yard, the great piles of lumber, some as high as a four-story house, were first shown on the screen, with the men at work stacking newly received lumber, or, preparing stock for removal to the dry-kiln. From this point the consecutive operations connected with the manufacture of Victrola cabinets were shown in detail including the cutting and carving of various parts, with scores of wonderful automatic machines of original design making for both speed and absolute accuracy; the staining and finishing of the complete cabinet after the parts had been assembled in a trifle over a minute, and the final inspection.

Next came the pictures of motor making which included views of the machines making all the various parts, even to the tiniest screws, the powerful presses for stamping out the spring cases and the machinery for making the springs themselves. The inspecting, testing and assembling of the motors was shown in a most comprehensive manner.

The pictures then lead through the various other departments to the shipping department, where machines were shown as they were finally inspected, crated, checked, and, lastly, placed in the waiting trucks for shipment.

No detail was overlooked and every operation was shown as actually carried on, general views of entire departments being supplemented with close up views of the actual operation of the various and wonderful machines.

C. G. Child Discusses Recording Problems.

After the presentation of the views of the manufacturing departments as relating to the machines, Louis F. Geissler, general manager of the Victor Talking Machine Co., introduced Calvin G. Child, head of the Victor recording laboratories, who gave a most interesting summary of the problems faced by those whose duty it is to secure the artists and select the music from which to make up the record lists. He said:

Some years ago, we conceived the idea that the only way to protect our business was, in the words of the phrase which we coined at that time, "to take it out of Coney Island." By that I mean to give it a permanent and authentic standing in the musical world; to make the Victor an acknowledged musical instrument by obtaining for you the best music and the greatest singers that were to be had in the world.

We have our dance craze; we have our rag-time craze; we have our good old summer times; we have the days of the Banks of the Wabash, and you know as well as we do, how short lived most of these sudden popular crazes are, they come as quickly as they go.

The backbone of the Victor business has been the Red Seal work, the records and music given to you by the great singers of the world who are

represented in the Victor catalog. It is just as necessary for me to make the contracts and arrangements for the Victor Co. with these people interesting and profitable as it is for the Victor Co. to give you a fair and generous profit on the business which you are doing, and we can only do this with your help.

The field of what is known as the bel canto music and style of singing of the older Italian composers grows more and more limited each year, and we are compelled to turn to the concert field and the concert repertoire to give our artists a certain number of new representations each year. It is a fact that Mme. Marcella Sembrich goes on concert tour through the United States and fills the theaters in which she sings, giving a wonderful program of Brahms, Schubert, Schumann, and that her audiences are always interested and instructed. It is a fact that perhaps one of the most successful concert tours in the history of concert managers was that of Miss Geraldine Farrar in the fall of 1913, and it is a fact that selections of this kind when listed in the Victor Co.'s catalogue meet with little recognition from our dealers, and a great many come back to us on exchange propositions.

I have in mind a little song of Mme. Schumann-Heink's "Die Forelle" ("The Trout") a little fishing story in German. The sales on this record have been so very small that we feel almost compelled to withdraw it from the catalog; yet all my friends who have heard this record are delighted with it. Some friends from Chicago said on hearing the record, "that brings me nearer to Schumann-Heink than I have ever been before."

We listed quite a number of the selections which Miss Farrar was to use from coast to coast in her concert tour last year and the majority of them have met with the usual lack of success of concert songs listed in our catalog. I do not know to just what cause this lack of interest in this better music may be attributed. It is not quite as easy to sell as "Care Nome" or the Miserere from "Il Trovatore" or the Quartet from "Rigoletto," but as soon as the patron becomes interested in these better things, he will turn more and more to them.

I find with much regret that quite a few of the Victor jobbers with whom I have talked, do not really know the monthly bulletin. It would seem to me that with the great interests which you have in this business, a serious study of the monthly bulletins would be of wonderful help.

We must go on making records by our big artists; we must show them each year an increasing royalty account for selling their records; royalty is the only way in which we can keep the artists alive to the interests of the Victor Co., therefore, I ask you gentlemen if you will not try and aid us in an effort to make this really better historical music in Victor records move faster than it is doing at present.

The profits on the Red Seal records are greater to you than any, and we believe that a careful study of the lieder and concert songs by your sales people will awaken them to the possibilities of this kind of music, and we hope that you will see the real necessity of helping us to get better results from this field.

The activity of the records in our Red Seal catalog is one of the greatest importance to the Victor business, and I hope that you gentlemen will consider my appeal to look into the class of music to which I have referred and see if it cannot be handled and put before your customers in a way that will create a greater interest in it. There are few left of the older operas which we have not already drawn on very heavily. The new grand opera of to-day is largely a musical drama with recitative work and not with the

wonderful melodies which we find in things like "Traviata," "William Tell," "Faust" and the older operas, but the field of the lieder and concert songs is almost unlimited and we must draw upon it for future work and we must not permit our artists to become discouraged at their small sale.

I wish it were possible for you gentlemen and you good ladies to know these great singers as I know them. I am asked frequently: "Do you not have all sorts of trouble with these singers?" And I say frankly, very little. They have their temperamental side, without which no singer can be great; but I find them very human and I could tell you story after story of the great singers which would show you that they are all real people, with a very human side, all keenly interested in what we are doing with them and anxious above all things, to have their records just as good as it is possible to make them.

When we first began this work, almost anything was considered good enough by some of the singers, but they very quickly realized that if they did not sing the very best they knew how for their records, it reflected on them and not on the machine, and it is quite a common thing to have a date with one of the big singers cancelled, because while they feel that they are perfectly fit to go through an operatic performance before an audience in the opera house, they feel that they are not just in condition to hand down a record of their work to posterity.

We have had, at times, some criticism from you gentlemen on repetition of repertoire, but I ask you to look at your sales on such things as the Prologo from "Pagliacci" and other popular operatic numbers of this kind and I have to tell you that when a new baritone comes and makes a great success in "Pagliacci," we must give to you for the friends and admirers of that singer the "Prologo" and your sales show that this has been a wise policy.

I thank you very much for the attention which you have given these few remarks and I hope that they will have the effect of calling your earnest attention to the class of music to which I have referred.

Views of the Recording Laboratories.

Following Mr. Child's address there were thrown on the screen views of the recording laboratories with six prominent members of the Victor Light Opera Co. in the act of recording the Sextet from "Lucia," accompanied by the Victor Symphony orchestra. Next was shown the other side of the partition with the master record in the actual process of the making and then the record was followed through the various details of manufacture from the raw material and to the placing of the finished record in the envelope for delivery. The exhibition wound up with pictures of over six thousand employes of the Victor Co. leaving the various buildings of the plant—a veritable army of men and women of a distinctly high-type—and finally views of General Manager Geissler addressing the employes, and the members of the light opera company singing the Sextet from "Lucia" in the open.

The exhibition was opened with a short address by Louis F. Geissler, general manager of the Victor Co., and as the pictures were thrown on the screen they were explained by Henry C. Brown, advertising manager of the company who, with the assistance of the department heads, had gathered together a great fund of valuable and interesting information regarding the various sections of the work. He made an excellent lecturer.

The entire exhibition was both impressive and inspiring, showing, as it did, the inner workings of one of the largest manufacturing industries in the United States. It proved that the enormous

(Continued on page 32.)

MOTION PICTURE VIEWS OF VICTOR CO.'S PLANT—(Continued from page 31).

business of the Victor Co. is built upon a foundation of progressiveness and efficiency, although with all the progress it has not kept pace with the enormous increase in the demand.

Mrs. Frances E. Clark's Interesting Address.

Before the presentation of the motion pictures Mrs. Frances E. Clark, head of the educational department of the Victor Co., delivered an address on the progress of the campaign to place the Victor in the schools during the three years she has been engaged in the work.

Mrs. Clark's address, which was illustrated with an interesting series of slides showing the Victor in schools in various sections of the country, was as follows:

Education is and has always been the highest function of the State. Of what that education shall consist has furnished material for controversy in all ages, and yet, the processes of learning, the methods of teaching, the subject matter for instruction, have remained more stable than any other phase of the evolution of government. Recent translations of ancient tablets, buried for eons of years, give their mute testimony of the learning of ancient people in the forgotten civilizations of Babylon and Nineveh.

In the past decade our schools have been undergoing more vital changes in the fundamental purposes of education than has taken place in hundreds of preceding years.

Our colleges are based squarely on the traditions of Cambridge and Oxford; our medical and scientific schools largely on the great universities of Germany; our law and theology on that of ancient Rome, by way of the wonderful schools of England.

Our high schools were but modified, miniature colleges, and the grammar schools were forced to adapt their courses of study to serve the high schools in the latter's efforts to fit the entrance requirements of the colleges.

As standards advanced, the entire cycle became enslaved to pedantic courses of study, growing more and more away from the real needs of life of a great majority of the people, and at the worst, artificial, stilted and inadequate.

The great impetus given to industry and manufacture by the discovery of new methods of making iron and steel with anthracite, the discovery of gas and oil, the discovery of gold and silver and copper and other metals in commercial quantity, the invention of many labor-saving machines, and more than all these by the stupendous movement of immigrants from caste ridden Europe, rushing here to better their condition, demanded a revolution in educational methods. The schools were slow, frightfully slow, in responding, and so steeped were they in tradition that not until ten or fifteen years ago did the movement gain much headway. Then manual training was cautiously introduced, trade schools were established, a taste of domestic science, cooking and sewing were tried for girls, and finally trade schools for these as well as for boys. Finally the whole educational world became intoxicated with the new idea, and went literally mad with zeal to introduce vocational training. Industrial topics filled the program of our conventions to the exclusion of other subjects. Out of it come a great awakening in our greatest asset, agriculture. Boys and girls' clubs were formed and two ears of corn were made to grow where one grew before. School gardens have taught a great art. The agricultural schools have brought scientific farming, which, with irrigation, has transformed millions of waste acres into homes. A healthful respect for manual labor has come, and in all the schools has arisen a desire to aggrandize real knowledge of real things.

At one commencement a few weeks ago, all the graduation exercises were concrete illustrations of helpful things learned in the course. One girl with tubs and modern equipment, taught how washing should be done. One boy illustrated, with a real pony, the care of horses—another with block and cleaver, and a dressed veal calf, taught the science of meat cutting. This is an improve-

ment over the "Beyond the Alps lies Italy" stage, and argues well for the future.

With all this much needed reform there has been a very grave danger of too radical a departure from time honored standards amounting in places to a sort of moblike cry for throwing away everything save a smattering of the sacred three R's. Leading educators are now counseling caution and pleading for a clinging to the cultural studies that must be taught if we would not subordinate our schools wholly to the commercial, industrial and utilitarian. A program being given this week at the National Education Association in St. Paul has such titles as "Training For Social Responsibilities," "The Humanities, Old and New," "Vocational Education, its Menace," "Let Both Grow Together Until the Harvest." Some culture for the masses we must retain or forfeit utterly the respect of Europe's civilization and descend to the mere money grubbing of which we are accused.

Next to reading and literature, music contains more elements of culture, refinement and beauty than any other one thing. It is universally innate and touches individual and community life in more places and in more ways than any other one branch taught in the schools. It possesses also remarkable powers in mental development, quickens the imagination, stirs and controls the emotions, and takes high rank in disciplinary, remedial and medicinal powers.

It was not then wholly theory that led up to the inauguration of this nation-wide movement of using "The Victor in the Schools" but a knowledge of conditions in the education world.

Co-incident with the recent great awakening in music in all lines, the school people were discovering that music possessed intrinsic merit—at once cultural, delightful and strongly educational. How to get enough of it to do any good was the problem; sight-singing was not enough; rote songs were not adequate; very occasional concerts by local artists only isolated cases in a great desert—and then—under Divine Providence—came the perfection of the Victor and Victor recording of the great music of the world which could be brought into every school, suburban or rural—and to the hearing of every child—not for amusement, not for entertainment (although it is entertainment of the highest order) but for a great and vital power in education.

Lincoln once said, "You can fool some of the people all the time, and all the people some of the time, but you cannot fool all of the people all of the time," and the great underlying fact which accounts for over 1,760 cities accepting our educational plan is, that it has in it inherent truth—it is of real use and genuinely educational—it suits the needs of the school people everywhere and furnishes at a most opportune moment an acceptable diversion from the industrial craze, and, happily, one that is entirely democratic, equally loved by all the children of all the people.

While we have sought to furnish special records to fit in with the special activities of the school day, the great field lies in the realm of appreciation of great music.

Just what is meant by appreciation of music? It is a term being used and abused indiscriminately. Appreciation of anything means that one understands it or can assimilate it and make it one's own, or that one can compare things known and relate them to the like unknown; or to estimate or judge of the merits; or to esteem and value highly. To appreciate an ideal thing, to build a vivid mental picture of things not seen, or to create a tonal conception of things not heard requires an experience in like sights and sounds as material for evolving such ideals. Our ideals are mirrored in our reals. No ideal is attained without having achieved many reals on the way.

Aspiration is creating images of the ideal from the materials of the real things at hand. Dr. Winship says, "Appreciation is the real thing while aspiring to the ideal thing." Appreciation is picking a bale of cotton while aspiring to "Wear a white robe all over God's Heaven." Appreciation is building a home in a two acre lot full of beautiful trees while aspiring to walk down "Unter den Linden" or visit Westminster Abbey.

One person can appreciate a great painting, because he has studied balance, tone, perspective, values and color. Another sees only a picture.

One walks through a woods and finds beauty at every step—trees are recognized by bark, leaf, limb—here a medicinal plant—there an orchid—on that twig hangs an oriole's nest—in that hole a flicker's—in that tuft of grass a flock of quails

—over on that swinging reed a red wing and on that thistle a gold finch; here a trillium, or May apple, or a Judas tree, or a thorn apple. Another walks stumbling along, merely grateful for shade. "A primrose by the river brim, a yellow primrose was to him—and it was nothing more."

One walked through the electrical display at the Buffalo Exposition and saw visions—another thought the lights pretty. One goes into a great machine shop and is thrilled and learns something from every bolt and screw—another is merely annoyed at the noise.

To appreciate music, in one sense, means that one must know enough music to be able to judge correctly of relative values—in another sense, that one has heard enough to have created a love and desire for hearing more of it.

A Victor in a school, properly used and sufficiently equipped with educational records, is a well spring of Victor publicity, and an open sesame to every home in the community. The school Victor is only the Joshua who spies out the Victorland for the whole army of people, who hear of it through the children.

We are proud of our 1,760 cities and the thousands of schools who have followed our plan. Without any doubt six or seven million children are now becoming Victor enthusiasts through the schools and considering the three years of effort, this is astonishing and most gratifying, but we have only just begun. The great field of the rural school is not yet touched. There are 212,000 one-room rural schools enrolling 6,700,000 children. In two or more room rural schools there are enrolled 4,466,000. We have only nicely started in the best of our States and cities. There are over 525,000 schools in this country enrolling 22,900,000 pupils, and we have as yet reached but a comparatively small per cent. In 1911 there were 10,234 public high schools and 1,781 private high schools, enrolling 1,115,326 pupils, in every one of which should be a Victor. Since 1911 this number has been materially increased.

This present year there were graduated from the elementary schools 1,600,000 pupils; from the high or secondary schools 160,000; from the normal schools 35,000, and from the colleges 25,000, totaling 1,940,000. As each June sends out of the schools a new army of graduates to take their places in the world, each September fills the broken ranks with many times as many more.

In addition to these schools there are evening schools, continuation schools, business schools, music schools, the prison and reformatory schools and the entire list of Governmental Indian schools, totaling 1,300,000 pupils.

Is it not plain that if 1,940,000 pupils graduating from the schools this year (and a like or greater number next year, and the next) may, by means of the Victor service, hear the music of the masters during their school life, that we shall have set in motion the greatest force ever known in the history of the world for the building of music appreciation—a love for and working knowledge of music in all forms?

These pupils going out into life, forming homes and furnishing the most valuable addition to our labor quota, must, in the next ten years, form the most vital element in our body politics, for our schools are the melting pots which transform all elements into our composite civilization.

If the 20,960,000 undergraduate pupils may have the same opportunity to learn to appreciate and know the music of all nations, in all ages, we have an immediate audience of startling proportions. If even 75 per cent. of all these pupils carry this enthusiasm and much of the actual music into the homes to three other persons, which is the average, our audience is multiplied to the astonishing number of 74,425,000. Here is missionary work worthy the devotion and consecration of our best efforts. A missionary brings good tidings to needy souls. The schools need good music—we have it.

The Victor Co. is sending good music to the children of America and through the children to the homes. The desires, wants and needs of the children are the most potent appeal that can be presented to fathers and mothers, relatives and all lovers of children. The Master knew this when he said, "And a little child shall lead them." Victor music in the hearts and on the lips of the children of America is not only the highest possible endorsement from a commercial standpoint, but it is far more and infinitely higher than that. It is our power for good under God's hands for the betterment of the race to each life touched. "The Victor in the Schools" brings "Light in dark places," carries joy, delight and happiness to the children of whom Dickens said:

They are idols of heart and of household;
They are angels of God in disguise;
His sunlight still sleeps in their tresses;
His glory still gleams in their eyes.
Oh those truants from home and from heaven,
They have made me more manly and mild.
And I know now how Jesus could liken
The kingdom of God to a child.

Annual Banquet of The Jobbers' Association

Held at Barnay's Restaurant, Atlantic City, on July 7, Was a Notable Affair—Over Two Hundred Jobbers and Guests Present—Addresses Made by Louis F. Geissler, Col. Edward Lyman Bill and Congressman McCoy.

(Special to The Talking Machine World.)

ATLANTIC CITY, N. J., July 8.—The annual banquet of the National Association of Talking Machine Jobbers, for which elaborate preparations had been made, was held at Barnay's Restaurant last night and was particularly notable for the large attendance, over 200 jobbers and their guests being present. The committee had worked hard to make the banquet a success, and despite certain drawbacks due to the service offered achieved its purpose in a most satisfactory degree.

The menu was presented in a most attractive form in a folder of sky blue, printed in dark blue and silver; a most effective combination. The dinner proper was carried on amidst general jollification. Burton J. Pierce and his famous "Angel Chorus" to the number of thirteen occupied a large round table in the center of the room and made themselves heard at the slightest excuse. The banqueter who did not make an effort to add to the general joyousness was mighty lonesome.

Following the lighting of the cigars, James F. Bowers was introduced as toastmaster by Joseph C. Roush, the retiring president, and proceeded to attend to the duties of his office in his well-known and inimitable manner, first paying a most graceful compliment to the many ladies present, and thus insuring respect and attention.

The toastmaster introduced as the first speaker Louis F. Geissler, general manager of the Victor Talking Machine Co., who was received with tumultuous applause by the assembled diners and who said:

Louis F. Geissler's Address.

I express my appreciation of the honor of being again requested to address your association.

This is the eighth consecutive year that this compliment has been paid me as the representative of my company, and, as the years have rolled by, the members of your association and your families have grown closer and closer to me and entered into my business life, until you have pre-empted the recesses of a very friendly heart.

In consequence of the frequent and pleasant meetings with your committees, and our distributors in person, it becomes increasingly difficult to hit upon a subject for discussion here that has not already received attention at such meetings, and I will refrain from recapitulating statements made at past annual banquets, as it seems to me that I have covered in past talks all the main points of our own company's organization and its condition as well as the patent field in its generalities as far as you would be interested.

I have also, from time to time, appealed to you for co-operation and assistance in defending your own and our position in the fields of patents and commercial methods and I may say that, with very few exceptions, we have to thank you for the heartiest response.

Improved Methods of Merchandising.

We are, moreover, thankful to-day for the very evident disposition on the part of dealers and merchants generally throughout America to take a prominent and assertive position in the ranks of those merchants committed to broad, decent and fair methods of merchandising.

Since your last annual meeting, we have passed through one of the most crucial tests in our history; I refer to the unsettlement and doubt relative to the maintenance of the one price system as engendered by recent court decisions and agitations, which happily have almost disappeared and our dealers have gone on their way, with the least possible inconvenience to their business, endorsing and showing thereby the utmost confidence in the newly adopted distributing methods of our company.

No one can expect uninterrupted and unqualified success in any enterprise or undertaking—there will always be ups and downs—but, during

this time, there has been no toleration of the degrading practices of price cutting nor will such practices, in the future, become more than a passing incident in the history of the art.

A Prophecy That Was Fulfilled.

I would like to quote one of the opening paragraphs of my talk to you last year at Niagara Falls, touching on the business conditions then existent. I said, that:

"While probably few of you have been affected and some sections of the United States are absolutely free, there is no doubt that taken in its entirety, i. e., including the field of industrial securities, there is a declining tendency noticeable in total business results. However, the continuous and increasing demand of ninety-five million popu-



Louis F. Geissler.

lation in this country, to say nothing of our wonderfully increasing export trade, is always sufficient to make certain a vast volume of business for the merchant and manufacturer."

Notwithstanding the demonstrated truth of that statement of a year ago, you all know how we have been blessed with a peculiar success, not only during the last half of 1913 but the first half of 1914; but, to claim that business conditions at the present time are generally satisfactory would be foolish.

There are several and various causes for business depression apparent to us all, but every man of business experience and thought realizes that it is only a question of time when we shall see a decided improvement and this country will again surpass her past records for prosperity. Evidence accumulates that nature is this year determined to compensate us for the afflictions or deficiencies of business or politics.

Your ever increasing success—which is reflected in our own—at times when other industries are not prosperous, is inconceivable to outsiders, and, in some cases, has aroused a spirit of jealous envy.

The failure of imitators and usurpers to successfully detract from your success must be apparent on all sides. The "bigness" of your success has been, and will continue to be, the magnet to draw the attacks of pigmies.

The "big things" that our Government has accomplished and the big things that private citizens have achieved were once the glory of America and have been our boast.

It is an easy matter to find people who will whack and hammer the prosperity of the successful. Few people realize how interwoven are the interests of all.

A Mania for Littleness.

The recent proposal of one of our senators that no corporation in any line of business should be allowed more than a specified capital is characteristic of the mania for littleness which has seized on the legislators, but, when the destinies of nations are determined by most colossal international trade wars, who shall and how can we restrict the assets of American giants without respect to the enormous resources of their competitors; it would conduce only to America's downfall, for there is no place for pigmies in a war of titans.

Roosevelt remarked but a few days since—and I hope his sentiment may be a plank in the platform of any winning party: "That we must encourage honest business and allow that business concentration which will give the power necessary to serve. This policy of the encouragement of decent business is as important to the welfare of our people as is our other policy of effective warfare against corrupt and unfair business."

Size and strength are, however, by no means synonymous; sad is the lot of the giant in business who lacks the strength to bear the burden of his size.

Abraham S. Hewitt once remarked that "Many large combinations carried within themselves the seeds of suicide." He referred particularly to abuse of power to control output and prices, and, through the unfortunate history of great business concerns which have unduly expanded within the last generation, this fact has been frequently illustrated.

Fortunately for us, and our constituents, there are no entangling alliances, no combinations or understandings with competitors to hamper us in an expansion with which we hope to successfully cope.

I should like to take this opportunity to impress upon the minds of my merchant auditors, in connection with the laudable ambition to do a big business, that all important—but recently hackneyed—phrase of "Safety First"—"Safety First."

For Permanent and Healthful Increase.

The Victor Co. is very anxious to go on increasing its business, but along permanent and healthful lines—through certain mediums and a certain quality of concerns, which are, in a great measure, a guarantee of permanent success.

Relative to expansion, it may be that even we do not appreciate nor grasp the possibilities of expansion in the talking machine trade, but, at least, we have been proof against allurements and blandishments on dozens of occasions where our goods have been sought in enormous quantities by those whom we considered undesirable representatives.

We have inveighed against inordinate expansion on the part of those with more enterprise and imagination than cool judgment and capital.

We quite naturally desire our distributors and dealers to continue successfully in their present expansions; but—"Safety First"—not a permanent dollar is to be gained by dangerous accounts. Your own bad debts and your own overstocked dealers are our liabilities; we would pay, in the end, by a decreasing business and loss of enthusiasm for our wares. We do not consider a machine nor a record really sold until it has reached the hands of the consumer.

On the Subject of Credits.

Your credit department is either one of your most expert salesmen or a serious drag upon your business.

(Continued on page 34.)

BANQUET OF THE NATIONAL ASSOCIATION OF TALKING MACHINE JOBBERS—(Continued from page 33.)

I would not for a moment create the impression—I would not dare to talk on this subject if I thought to create an atmosphere of ultra-conservatism. I plead for extensions of credit, with judgment; for a credit that can safely be extended, not meaning to coldbloodedly extend or restrict credit on a mercantile report—I mean to suggest most careful personal investigation of your debtors by your credit man.

The fact is, our business lends itself peculiarly to extensive credits and more especially on the part of those who are dealing in talking machines exclusively—practically, those dealers must fail in business to cause you loss and this is not a frequent occurrence and will not be unless they fail to exercise proper business judgment and precaution by limiting their credits and enforcing their collections.

You are not doing the overambitious young merchant a kindness by encouraging him to go too far beyond his capital or immediate good prospects for business; you would be spoiling your customers and you would soon have them in an unhealthy and hopeless condition, harassed by a financial condition that detracts from their efficiency as a salesman.

* * * *

In those of you who retail largely, there lurks a germ which I fear—I refer more especially to the piano and instalment houses.

I know just how easy it is for a concern, habituated to piano instalments, to attempt or incline to apply piano reasoning and financing to the Victor or Victrola business.

I beg of you to see that your Victrola department stands on its own feet; that the small percentages of piano payments are not applied to your Victrola department—it is not necessary; your customers do not expect it, and, in some cases, it will quickly consume your capital, and stop healthy progress if you persist in it.

If each of you would make up your mind to let the "other fellow" have the undesirable business, the undesirable business would disappear.

I was once told by a senior partner that "There are plenty of good people in this world to sell goods to without going after lame ducks." This is absolutely true.

A Lesson from the Piano Men.

You all have had experience with piano salesmen who seem to be totally unfit to talk to anybody that can afford to pay over \$6 a month on a piano and who always meet with the utmost success in reducing a \$20 a month prospect to a \$10 a month payment and then exult over their doubtful success.

You all know that there are peddlers by the thousand who could never think higher than 25 cents a week payment on a rug or a clock—don't employ that kind.

The Victor Co. does not propose to finance that kind of a distributor and the distributor should not, and cannot (if the prescribed Victor credit terms are conscientiously complied with) carry that kind of a dealer. Your aim and ours must be to so conduct our business as to conduce to the longevity thereof—to reiterate—"Safety First."

Forming Dealers' Association.

I am pleased to note that my suggestion of last year that "You form and encourage to be formed dealers' associations in the respective cities" has been acted upon to some extent.

The talking machine trade people are a friendly people—generally more friendly than many other lines of competition—and the spirit of fraternity and courtesy, one to another, will change the entire atmosphere, remove damaging and cutthroat competition, and, if this association effort is persisted in, there can be established, through it, in each city a spirit of friendly, though active, competition and a confidence and candor as gratifying as that which we can flatter ourselves exists between us here.

I will not attempt to make promises or prophecies at this time relative to Victor goods nor Victor improvements or innovations. I have

nothing sensational to spring—I will only state, generally, that our laboratories are as busy and enterprising as ever. You will have new goods or improvements as rapidly as we think you can healthfully digest or take care of them.

We shall continue our efforts to justify your confidence in us and our policies, and I beg for your continued interested assistance in carrying them out in every detail.

I beg that you will not be sidetracked or attracted by seemingly profitable "side lines" of a



James F. Bowers, Toastmaster.

claptrap character. You are directly attacking your own interests as well as ours by such.

In closing, I desire to congratulate your association on this wonderful convention; you have attracted this year many faces unfamiliar to previous conventions, and I hope you will all return to your homes feeling that you have done yourselves and the manufacturers much good by your visit.

The next speaker was Col. Edward Lyman Bill, editor of *The Talking Machine World*, who spoke as follows:

Col. Edward Lyman Bill's Speech.

Caruso, a link in the artistic chain with which you are all familiar, was motoring in the country recently when his car broke down in the midst of a severe storm, and while the chauffeur was repairing it he entered a farmhouse to get warmed up a bit. He chatted with the farmer before the wood stove in the kitchen, when the latter asked him his name and he told him it was Caruso. At that he threw up both his hands. "Caruso,"



Edward Lyman Bill.

he exclaimed, "Robinson Caruso, the great traveler! Little did I expect ever to see a man like you in this 'ere humble kitchen." Even the farmer was a link.

Link by link the chain of business success is forged, and it is of the utmost necessity that each link be strengthened in every possible way, because, should there be a weak link, when the crucial moment comes the chain is parted, and to repair it may mean material loss. It may mean a serious setback while the machinery is halted undergoing repairs.

Chains should be constructed with a careful avoidance of weak links, because when the stress and strain comes a sad collapse may occur.

A great link in the business chain is the manu-

facturer, the one who produces. This link should be strongly welded and should be composed of forces which will stand any strain, for if a weakness occurs in the producing link then disaster is bound to follow.

In the talking machine trade the manufacturing links have been composed of elements which have withstood the strain and wear to which industrial and commercial usage subjects them.

Another important link is the jobber—the intermediate link between the manufacturer and the dealer. The jobbers are dealing with large interests, and it is necessary that their link be composed of fine metal capable of standing terrific strain.

Then the next link is the retailer, the man who sells to the ultimate consumer. This link in the business chain is brought into the most intimate contact with our purchasing public. It is perhaps more delicately susceptible to public sentiment than any other composing the chain. It is a link which easily gathers a big accumulation of grievances, and it is too close, perhaps, to the consuming masses to ever be wholly removed from them.

Another important link is advertising; the power that creates demand; the power that acquaints the public with what man has accomplished in the special fields of human endeavor; the power that makes the industrial world move on. This is a chain that creates vast aggregate buying power, and, I may add, that it was not long ago when this power constituted an exceedingly weak link in the chain, by reason of the dishonest methods adopted by some national advertisers.

If it be criminal for a salesman to lie and to deceive one man in trying to close one sale, is not the advertising man or the publisher equally criminal when he spreads that lie before the confiding eyes of millions of Americans? But happily that link has been strengthened and some of the men who years ago were putting forth misleading, dangerous and lying advertisements have now materially changed their policies.

The people are entitled to protection, and advertising is too vast a power—too noble a calling, to suffer from the misdeeds of the few.

In the old days trickery and deceit in retailing was aided and encouraged by fraudulent methods of publicity, but as in everything else the world had to be educated. It has been a slow process, but no one can deny that within the past ten years marvelous steps have been taken which makes merchandising better and advertising cleaner in all lines. We see these conditions reflected in the publicity world, in the link in the chain in which I am specially interested.

There are plenty of papers that will not accept questionable advertising, or advertising in which there is an element of doubt as to the ability of the advertiser to live up to the statements made in his announcement. In other words, the advertising pages of the big publicity mediums reflect honesty in merchandising in a greater degree than ever before. Hence it means, as a natural sequence, that out of these conditions there should come price standardization.

Now, unless there be fixed prices, what is the real object of manufacturing institutions spending millions of dollars to create a trade-mark value in the homes of purchasers? If advertised articles can be cut and slashed according to the whims of the price-cutter, then why advertise to reach the public because everyone knows that price-cutting has no other effect than the lowering of the standard of values, and surely the individual or corporation whose money is invested in a manufacturing enterprise has the right to say what the public shall pay for their articles. Surely the public will not pay more than an article is worth and continue to purchase it.

The manufacturer's rights should be respected, and when one price is established generally by manufacturers, the unscrupulous merchant will be forced to abandon his plan of substituting cheap and inferior articles for the standard. In this way the producer will be a stronger link in the chain, for he will secure in a larger degree his rights as a maker, and the retail link will be

BANQUET OF THE NATIONAL ASSOCIATION OF TALKING MACHINE JOBBERS—(Continued from page 34).

strengthened because it will have a guarantee of protection in so far as price and quality are concerned, and the whole system of bartering and haggling, which almost amounts to a battle of wits, will be done away with.

The Supreme Court, by a hardly understandable decision, has stated that the maker of a nationalized product has no right to say how much the retailer shall ask the public for it, and yet the Government compels the railroads to maintain one price for all, and would not this provision prevent the manufacturer of trade-marked articles from doing the same thing which the Government exacts from the railroads?

With a standard trade-marked article the small dealer can meet in successful competition the large trade organization which has millions of assets, and yet cannot offer a standardized article at a less price than the small dealer who may occupy an obscure position in a great city.

The trade-mark is the rainbow of trade—without it modern advertising could not exist, and one of the great links in the business chain would be materially weakened. There could be no standardization of values and prices—no profit assurance for the future.

With a trade-marked article, a good merchant is always able to cope successfully with unfair competition and he is assured of a continuity of profits to a degree not deemed possible through any other means.

And so, we are all links in the great business chain, and we should remember that the chain is no stronger than its weakest link.

George D. Ornstein Arouses Enthusiasm.

The toastmaster next called upon Geo. D. Ornstein, manager of salesmen for the Victor Talking Machine Co., who was enthusiastically received by the assembled jobbers, who took the occasion to show their great respect both for Mr. Ornstein's personal characteristics and his ability in his chosen field.

L. S. Sherman's Address.

Mr. Ornstein delivered a short talk in a happy vein and was followed by L. S. Sherman, of Sherman, Clay & Co., San Francisco, who gave some interesting reminiscences of the manner in which Mr. Geissler first became connected with the talking machine end of the business while employed by Sherman, Clay & Co. and cast his lot in a new field to meet with the success that has attended his efforts.

Mr. Sherman told of the employ of Mr. Geissler to take charge of the small goods department of his house nearly a quarter of a century ago, and said regarding subsequent happenings: "In the very infancy of the talking machine industry, even before it had fairly started in this country, to use a Frenchman's expression, a wholesale liquor dealer came to me in the 'garbage of a gentleman,' stating that a sample talking machine had been sent out to him from New York with the request that his house take on the representation of it or place it with some responsible concern.

"As it was claimed to be a musical instrument he came to see me.

"If we were to take it on I realized that it should be handled by our small goods department, so I took the gentleman to Mr. Geissler's office.

"From the result of that interview the sample was sent us to inspect. The machine told some funny stories and made an attempt at being musical.

"A sample order was placed, soon followed by many others, and we became fully launched in the talking machine business. The business at the factory end was poorly handled. I believe they tried to run the factory from the lawyer's offices, where most of the stock was owned.

"The principal owners wanted us to buy some of the stock. There seemed to be signs of approaching disintegration that gave no hope for future permanency with them.

"Mr. Geissler was so dissatisfied with existing conditions that he came East to thoroughly canvass the situation.

"The result of that trip was that Mr. Geissler decided to cast our lot with Mr. Johnson and Mr.

Douglass; the wisdom of that throw has long since been verified.

"I do not have to tell you the history of the talking machine business since Mr. Johnson and his associates entered the talking machine arena, for you all know of the foes they have vanquished and of the victories they have achieved.

"When Mr. Douglass' health became impaired, necessitating his taking a complete rest, the Victor Co. needed a big man to fill a big position; they complimented our house in placing their choice upon our most important man.

"Mr. Geissler was an honored director and officer in our corporation; he resigned his position with us to assume the great responsibilities which now devolve upon him.

"You can now appreciate the importance of the little ad I wrote more than twenty-five years ago and its present influence upon the talking machine industry in transferring Mr. Geissler from the Doman Music Co., of Nashville, Tenn., to the responsible position he now occupies with the Victor Co. All credit to him for the transfer."

F. K. Dolbeer Well Received.

Frank K. Dolbeer, who recently joined the forces of the Victor Co. as credit manager, was next introduced and was accorded a hearty reception by his many friends among the guests. Mr. Dolbeer expressed his appreciation of the honor paid him in a graceful manner.

Walter I. McCoy Discusses Price Maintenance.

The final speaker was Congressman Walter I. McCoy, of the Ninth New Jersey District, who delivered a lengthy address on the subject of unfair competition and who dwelt at some length on the question of price fixing. Mr. McCoy explained the Sherman law and its aim and objects in a broad way, and cited a number of decisions of the Federal courts in some of the best known cases tried under that law, including the Standard Oil and the tobacco cases. He outlined just what the law was designed to accomplish. In the matter of price fixings Mr. McCoy said in part:

The court, as you know, has in several cases passed upon the question adversely to the right to control resale prices. Your contention is that under certain circumstances and surrounded by proper safeguards the fixing of resale prices, especially if it is accompanied by standardization of prices, is an economically sound proposition which, put into operation, will in the end and on the whole result to the benefit of the consumer, and so far as I am concerned I believe that your contention is sound. I do not propose to elaborate the arguments which to my mind lead to this conclusion. I have heard them made so ably before the Committee on the Judiciary of the House of Representatives by persons whose competency to make them is based on large experience and deep study, and whose arguments I know you have read, so that I should be simply carrying coals to Newcastle if I were to attempt to go into that particular part of the discussion.

Selfishness Behind Price Cutting.

I have been satisfied by those arguments that many of those who indulge in price cutting do so solely for their own selfish purposes; that they have not the slightest desire to serve the public by giving them good value at a low price; that in using standard and largely advertised goods as leaders at cut prices they are morally, if not legally, taking another man's property for their own benefit without any return for its use; that in the long run the net result of these unfair methods will be to deprive the community of its power to purchase some standard articles bearing a good reputation at any price at all, and in many other instances to put communities, especially small ones, to great inconvenience through their inability to have such articles at hand where they can easily be purchased, thereby forcing them to do business with non-resident dealers. I believe that many other evils result from these unfair practices, but, as I say, you know them better than I do.

Is there any ground for hope that the Supreme Court, in view of these considerations, may change its view as to price fixing? Very little, I should say, notwithstanding that, as I have stated, it has

apparently left to itself by its opinions on the Sherman act the power largely to guide a development of the law as though there were no statute; and, of course, courts have been known to reverse their previous decisions.

It is strange that it is possible for a man to part with the good will of his business and to agree legally not to compete with the purchaser of it while, on the other hand, a man may not sell the product of his business, but may not protect the good will of it by making a reasonable contract as to that product—the man who is going out of business may protect another, but the man who stays in business may not protect himself though injuring no one.

Remedy in Legislation.

If I am right you are left to legislation for your remedy, and it will probably have to be legislation like the Stevens bill directly establishing your right to fix prices, for it is not likely that any bill creating a trade commission will for the present at least give you relief, though the bill entitled "Act to Create a Federal Trade Commission" proposes to make unfair competition unlawful. The Sherman law will still be in your way.

You have before you a hard task and you might better admit it, however clear to your minds is the justice of your contention. Legislative sentiment is against you to-day, I feel certain, and so perhaps is public sentiment—at any rate, the majority of members of Congress whom I have talked to have that belief. If public sentiment is against you you will have to change it. If, in addition to that fact, Congressional sentiment is hostile, you will have to demonstrate to Congress through the public as well as by hearing that none of "the evils which led to the public outcry against monopolies and the final denial of the power to make them" are likely to result from legalized price fixing. Those evils are stated by the Supreme Court as appears from one of my previous quotations, to be (1) injury to the public; (2) limitation of production; (3) deterioration in quality, demonstrate not only that none of these evils come from price fixing, but show affirmatively that the very opposite is the case and you will succeed especially if you can demonstrate further that if you are not given the right which you seek, the practice of retail distribution as now prevailing may be seriously curtailed if not wiped out and a retail monopoly established in its stead.

How the Stevens' Bill Will Help.

As I read the Stevens bill, which undertakes to give you the right which you want to have, it successfully guards against the evils which were enumerated in the Standard Oil case, for it gives you nothing if you have any monopoly or control of the market for articles belonging to the same general class of merchandise as that in which you are dealing; or if you have even so much as an "understanding" with a competitor in regard to prices, and it is the possibility that such understandings can be more easily arrived at if you have the power to fix prices, which is used as one of the strongest arguments against your contentions. The provision in the bill for a standard and publicly announced price will go a long way, I believe, in bringing public sentiment to your side of the proposition.

It has occurred to me to suggest that maybe you will have to accept a provision which will provide that the prices fixed for any article shall be reasonable. Of course, the objection which is immediately raised to such a proposition is that it will lead to uncertainty and litigation, but the fear of unreasonable prices is one of the things that have stood in your way so far as Congress is concerned, and, in fact, is the very fear which leads to the enactment of the Sherman law, namely, that under monopoly or partial monopoly prices are raised to an unreasonable height.

The only people who can be flattered by telling them they are clever are those who aren't.

PROGRESSIVE JOBBERS ADVERTISE IN THE TALKING MACHINE WORLD. CONSULT THEIR ANNOUNCEMENTS.



View of the Banquet Hall on the Roof Garden of the Bellevue-Stratford on the Evening of July 8 During the Banquet Given by the Victor Co. to the Visiting Jobbers. This Was the Great Function of Convention Week, and at the Close of the Banquet the Assemblage Adjourned to the Dome Room Directly Connecting, Where It Was "On with the Dance; Let Joy Be Unconfined," "Till the Wee Sma' Hours.

The Victor Co.'s Royal Entertainment.

Members of Jobbers' Association Taken to Philadelphia as Guests of the Company for an Entire Day of Festivities—
Attended Interesting Baseball Game and See the Champion Athletics—Brilliant Banquet and Entertainment on Roof Gardens of Bellevue-Stratford Completes Enjoyable Day.

(Special to The Talking Machine World.)

PHILADELPHIA, PA., July 9.—The word "royally" has been used on many occasions to describe happenings of particular splendor, but the word has seldom been used with greater accuracy than in describing the manner in which the Victor Talking Machine Co. entertained the members of the National Association of Talking Machine Jobbers and their families who were the all-day guests of the company yesterday.

From the time the jobbers and their families boarded the special train at Atlantic City at 11 a. m. until they left for their respective homes this morning, every detail had been planned for them and set forth in a cleverly conceived time-table, illustrated with humorous sketches and which provided for every hour in the day. There was nothing left to guesswork. When the guests of the company arrived at the Bellevue-Stratford Hotel they found rooms assigned to them and their baggage carefully placed therein as the result of forethought of the Victor officials, and other carefully thought arrangements for their comfort and peace of mind were in evidence throughout the day.

Upon arrival at the hotel an elaborate buffet luncheon was served in the Clover Room, a luncheon thoroughly delightful in every detail. The party next entered automobiles, over fifty of them, flying the Victor pennant with the famous dog prominent thereon and started for Shibe Park, where the famous Philadelphia Athletics of the American League and world's champions for 1913, were scheduled to cross bats with the Detroit Tigers and face the peerless Ty Cobb. A large section of the upper grandstand of the park had been reserved for the Victor Co. guests, and a large sign running across the front of the stand proclaimed the fact with the Victor dog, highly magnified in profile board, prominent in the center.

Before and during the game the jobbers were entertained by the playing of the Victor Military

Band, which made its first appearance in public on that occasion. As the lively music was rendered between the innings, visitors kept time with the music by waving the Victor pennants with which each one had been provided, and the general effect was most beautiful.

That baseball is the national game was never more thoroughly demonstrated than by the jobbers. Men from Maine and Texas, from Illinois and Florida, vied with each other rooting for one or the other of the teams and in giving advice to the players in the recognized manner. The Athletics cleaned up with a score of 3 to 0, probably in honor of their distinguished guests, and immediately after the game the party was whisked back to the hotel to prepare for the elaborate entertainment of the evening.

It is probable that never before in the history of the trade has there been such a brilliant banquet tendered to its members, for the famous facilities of the Bellevue-Stratford were drawn upon to provide dinner and service measuring up to the exacting demands of those in charge of the arrangements, though the dinner itself was but a section of the program. Each guest found at his or her plate a beautifully engraved menu and program in book form and for the ladies there were also provided handsome bouquets of flowers. The menu was as follows:

Clover Club Cocktails		
Crab Meat Flakes Cocktails		
Consomme Bellevue, Whipped Cream on top		
Relishes		
Salted Almonds	Pecan Nuts	Celery
Barsac		Olive
Bonnd Brook Trout, Saute Meuniere		
Cucumber Salad, Pink Dressing		
Moet & Chandon White Seal—Cup		
Filet Mignon, Oriental		
Young Lima Beans		
Kirschwasser Sherbet		

Cold Pressed Rouen Duckling in Jelly		
Hearts of Lettuce Salad		
Coupe aux Peches, St. Jacques		
Flutes		Macarons
Cigarettes	Cigars	Liqueurs
Special Coffee		

During the banquet the diners were entertained by a vaudeville bill of exceptional excellence, supplied by professionals of reputation in the "big time" and who included Walter C. Kelly, "The Virginia Judge," and one of the most popular monologists on the stage; "The Five Seminary Girls"; Mlle. Meserau, Parisienne danseuse; several comedy and cabaret acts and other features of high class, including selections by the Neapolitans, a capable quintet of instrumentalists and singers.

Cablegram from Eldridge R. Johnson.

Just as the guests were seated Louis F. Geissler, general manager of the Victor Co., read the following cablegram from Eldridge R. Johnson, president of the company, who is at present in London:

"The Victor Co. has now reached the enviable position when it has the right to expect the respect and confidence of the trade. Tell our guests that my greatest ambition is for the Victor Co. to maintain that position and to continue the prosperity of all concerned with it in Victor policies by fair dealing. I congratulate you, the Victor organization and jobbers, on a splendid half year. Our business will prosper as we deserve it."

Mr. Johnson's message was received with great enthusiasm by the jobbers, and the following answer was cabled from the banquet hall to Mr. Johnson:

"E. R. Johnson, Gramophone Co., London:

"From the dinner table at the Bellevue-Stratford, the National Association of Talking Machine Jobbers sends to you best felicitations, and wishes for your continued good health and prosperity."

"GEORGE E. MICKEL, President."

(Continued on page 38.)



View of the Banquet Hall on the Bellevue-Stratford Roof Garden When the Victor Program Was Being Carried Out and Mlle. Meserau Was on the Stage. In the Center of the Room Will Be Seen the Neapolitan Orchestra Which Was Taken from New York for This Special Occasion.

THE VICTOR CO.'S ROYAL ENTERTAINMENT—(Continued from page 37).

Mr. Geissler then welcomed the guests of the evening in an eloquent manner, a welcome which the many members of the Victor organization supported by arising.

Edward Lyman Bill, for the guests, next proposed a toast of appreciation to Mr. Geissler, which was drunk standing and amid great enthusiasm.

Exhibition Dancing Interests.

Following the banquet proper, the guests repaired to the Dome Room of the hotel, where Holton Herr, the distinguished dancer and his partner, Miss Janet McIlwaine, with a corps of assistants, demonstrated the modern dances for the edification of the jobbers. A most interesting feature of this section of the entertainment was the exhibition dancing of Henry C. Brown, Jr., son of the advertising manager of the Victor Co., who, with his graceful partner, rank close to the top among the amateur dancers of the country.

The guests then took the floor and gave themselves up to the enjoyment of the art of Terpsichore until the early morning hours.

An Elaborate Entertainment.

The elaborate character of the entertainment, the machine-like precision with which the program was carried out, and the brilliancy of the whole affair will long remain fresh in the memories of those who enjoyed the privilege of being present.

The success of arrangements was due largely to the untiring efforts of Henry C. Brown, the popular advertising manager of the company, who was here, there and everywhere throughout the day and evening to see that there was no hitch in the plans. Mr. Brown had the assistance of F. K. Dolbeer, Ernest John, C. K. Bennett and other members of the Victor staff in looking after the comfort of the guests.

The spirit of camaraderie existing between the company officials and their distributors was never more forcibly illustrated than during the entire entertainment. It was a fitting climax to what is universally acknowledged to have been the best convention ever held by the talking machine men.

The Guests of the Victor Co.

The guests of the Victor Co. and the officials of the company who acted as hosts included Frank C. Allen, M. H. Andrews, Mr. and Mrs. C. N. Andrews, W. D. Andrews, J. C. Angle, R. H. Arbenz, Wallis F. Armstrong, A. W. Atkinson, Mrs. E. C. Babcock, Wm. H. Barker, Mr. and Mrs. T. W. Barnhill, Harry Beach, C. K. Bennett, Edward Lyman Bill, Mr. and Mrs. J. N. Blackman, E. P. Bliss, Mr. Blount, Mr. and Mrs. Emanuel Blount, Chas. Bobzin, J. F. Bowers, Mr. and Mrs. H. C. Brown, H. C. Brown, Jr.; C. A. Brown, Miss Editha Wells Brown, C. A. Bruce, C. F. Bruno, Louis Buehn, A. H. Buescher, Mr. and Mrs. W. H. Buescher, Miss Frances Bullard, Lester Burchfield, Mr. and Mrs. I. F. Burton, Mr. and Mrs. J. G. Card, Paul Carlson, C. G. Child, Mrs. Frances Elliot Clark, The Misses Cohn, L. W. Collings, D. P. Comerer, B. B. Cope, F. W. Corley, W. O. Crew, Mr. and Mrs. I. Davega, S. B. Davega, Olney Davies, Fernando DeArredondo, Mr. and Mrs. Albert Deisinger, W. C. Dierks, J. H. Dietrich, E. J. Dingley, Mr. and Mrs. F. K. Dolbeer, Miss Edna Dolbeer, Miss Dreschler, Mr. and Mrs. Dodin, Carl A. Droop, W. N. Dunham, C. H. Eisenbrandt, W. F. Eitler, Mr. and Mrs. Harry Ellis, W. J. Elwell, E. G. Evans, Lewis W. Fickett, Mr. Finch, J. Fisher, J. Frawley, W. F. Frederick, R. L. Freeman, Mr. and Mrs. W. B. Fulghum, Louis F. Geissler, Mr. and Mrs. A. D. Geissler, Mr. and Mrs. L. J. Gerson, Miss G. F. Golden, Mr. and Mrs. N. Goldfinger, J. W. Greener, E. Greenfelder, H. E. Green, Tom Green, I. L. Grinnell, Miss Grinnell, Mrs. Grinnell, C. K. Haddon, Mr. and Mrs. E. Paul Hamilton, Marquette A. Healy, A. G. Higgins, Mr. and Mrs. E. E. Hipple, Wm. Hooley, Henry Horton, A. Hospe, J. F. Houck, O. K. Houck, Mr. and Mrs. C. L. Howser, A. M. Hume, Mr. and Mrs. Geo. Huver, Ernest John, W. G. Jordan, E. I. Kern, F. R. Kessnich, E. T. Kieffer, J. B. Landay, Max Landay, Mrs. Lowenstein, Geo. Lyons, Mr. and Mrs. MacCall, J. S. MacDonald, G. A. Mairs, W. L. Marshall, A. G. McCarthy, Hon. Walter I. McCoy, Miss Rhea Mc-

Evers, J. E. Meagher, Geo. E. Mickell, Mr. and Mrs. John B. Miller, Mr. and Mrs. H. F. Miller, Mr. and Mrs. D. P. Mitchell, R. Montalvo, Geo. W. Morgan, R. H. Morris, Billy Murray, H. H. Murray, B. E. Neal, O. L. Neal, French Nestor, G. G. Neville, Mr. and Mrs. C. H. North, H. Nugent, Will Oakland, Mrs. J. T. O'Keefe, Mr. and Mrs. Geo. D. Ornstein, Dan O'Neil, W. E. Parker, J. J. Parmenter, Burton J. Pierce, Steve Porter, Clarence Price, Mr. and Mrs. M. G. Price, Fred H. Putnam, E. C. Rauth, W. H. Reynolds, W. G. Roberts, Robt. C. Rogers, J. C. Roush, S. H. Rous, Belford G. Royal, Miss Ethel Royal, Miss Ruth Royal, Mrs. Belford G. Royal, Herbert L. Royer, C. S. Ruggles, Mr. and Mrs. Harry Rupp, C. J. Schmelzer, H. J. Shartle, L. S. Sherman, Fred A. Siemon, Mr. and Mrs. E. K. Smith, Mr. and Mrs. I. Son Cohn, Miss Spaulding, Miss Ruby Spaulding, Mr. and Mrs. W. J. Staats, A. M. Stewart, Max Strassburg, Mrs. Strassburg, Benj. Switky, E. F. Taft, T. H. Towell, A. A. Trostler, E. H. Uhl, Mr. and Mrs. E. N. Upshaw, Mr. Van Winkle, Miss Ethel Vogt, Miss Watkins, Parham Werlein, Mr. and Mrs. Albert C. Weymann, Mr. and Mrs. H. W. Weymann, Mr. and Mrs. Wm. A. Weymann, Perry B. Whitsit, Mr. Williams, the Misses Williams, B. B. Wilson, H. A. Winkelman, L. C. Wiswell, Howard Wurlitzer, Raymond Wurlitzer, Mr. Wurtle, Mr. Young, H. E. Ziegler.

* * * *

Talking machine jobbers who visited New York on their way home to their respective cities were loud in their expressions of appreciation of the really magnificent reception given them by the Victor Co.—something absolutely unique in its way, and conducted in a manner so perfect and satisfactory as to show the extreme care with which everything had been handled in preparation for this event. It only goes to show that when the Victor Co. does anything in a public way it does it well.

PROGRESSIVE JOBBERS ADVERTISE IN THE TALKING MACHINE WORLD. CONSULT THEIR ANNOUNCEMENTS.

Yours For Better Victor Service!

COHEN AND HUGHES, Inc.

Victor Distributors

BALTIMORE, MARYLAND

WHEN YOUR LOCAL DEALER IS JUST OUT—TRY US—WE CAN SUPPLY YOU!

WE MAKE A SPECIALTY
of carrying
A COMPLETE STOCK
of the
SPECIAL FINISHES
in All Styles of
VICTROLAS

**SYSTEMATIC DAILY
RECORD ORDERING**

By our daily ordering of records from the factory, and anticipating our wants for 90 days on advance sales, we have now an almost COMPLETE STOCK. A visit to our enormous wholesale record rooms, where the immense complete stock is carried, will make good our assertion.

The profit made on one record which you cannot secure from your local jobber will not only keep your trade, but your profit on this one record will pay the freight on the entire shipment.

YOURS FOR BETTER VICTOR SERVICE

We ship by Parcel Post, Express, Freight and Boat, which is exceptionally low from Baltimore, and often less than shorter distance to you by rail.

ORDERS SHIPPED COMPLETE DAY RECEIVED

No Order Too Large or Too Small

Order Blanks on Application

COHEN & HUGHES, Inc., BALTIMORE, MD.

Kindly Mention The Talking Machine World.

Convention Snap Shots and Impressions.

O. K. Houck, of Memphis—there is only one O. K., so further details are unnecessary—arrived late on Sunday at Atlantic City, N. J., with his brother Jesse Houck and Olney Davies, and feeling fit for a strenuous session.

Mr. Houck, who is the Big Mastiff of the Ancient and Effervescent Order of the Yellow Dog, came to the convention with the paraphernalia for conducting the initiation of candidates into the noble order, and was busy every minute of the day initiating classes of candidates gathered together by



Big Mastiff Houck Conferring the Yellow Dog Degree Upon an Enthusiastic Class.

squads of willing workers. No one was overlooked, from Louis F. Geissler and other Victor officials, down to the hotel staff. Mr. Geissler's speech in German dialect after his initiation on the train bound for Philadelphia should be preserved in the archives of the order for all time. It was a classic.

Big Mastiff Houck explains the objects of the order to the candidates as follows:

"This is a little social order founded on friendship, fidelity and fun, fun being the potent factor of the degree.

"We call it the Yellow Dog. You might wonder why we would call such a magnificent order as this the Yellow Dog, but fidelity also cuts a part in this order, and there is nothing in this world so faithful to his master as a little yellow dog.

"You can kick him and cuff him around and starve him to death, and yet he is willing to lay at



Houck and His Yellow Dog.

your feet and guard you while you sleep; hence we take that name for our noble order. It matters not where your travels may lead, you will find Yellow Dogs, and when you find one you will have found a friend."

This is followed by the secret work of the order, much appreciated by those who can answer to the hailing sign of the Yellow Dog. Mr. Houck's work was the hit of the convention.

O. K. Houck, just to be remembered, brought with him and distributed nearly a hundred huge nickel-plated keys to the city of Memphis, each tied with a red ribbon and bearing the name of the O. K. Houck Piano Co. The keys were tried, but failed to open any of the refreshment parlors of Atlantic City until after midnight on Sunday, when the doors were opened to the thirsty hordes.

If the various jobbers have their way, the films showing in detail the manufacture of Victrolas and records will be shown before audiences in all sec-

tions of the country. Several of the jobbers are particularly anxious to show the pictures to their dealers, even if the public is not invited, believing that the immensity of the Victor Co. plant and its efficiency, to say nothing of the army of high-class workers employed and shown as they march from the buildings, will serve to leave a strong impression on the dealer and arouse his enthusiasm over Victor goods.

One of the jobbers to receive a particularly cordial reception was L. S. Sherman, head of Sherman, Clay & Co., and dean of the music trade on the Pacific Coast. Mr. Sherman made the trip for the fixed purpose of getting the next convention of the association for his own city, and his letters from the Mayor of San Francisco, from the Director-General of the Panama-Pacific Exposition, and other officials, coupled with his own eloquence, won the convention for the Exposition City without a dissenting vote.

Mr. Sherman declares that, although the distance is calculated to frighten some of the jobbers, the



The distinguished gentleman in the foreground is L. S. Sherman of San Francisco. At his right is H. C. Brown, Advertising Manager of the Victor Co. Just behind Mr. Brown stands Andrew McCarthy, of Sherman, Clay & Co., San Francisco.

fact remains that, with the special inducements offered by the railroads and hotels during the period of the Exposition, the cost of attending the convention will be surprisingly low and the presence of attractions of world-wide importance made the spring of 1915 a most favorable time for visiting the Pacific Coast. Mr. Sherman came armed with folders, rate sheets and other printed arguments in support of his contention, but he won his victory without being compelled to use them. "San Fran-



Left to right: Fred A. Siemon, Raymond Wur'tizer, Branson M. DeCou, W. A. Condon, C. S. Ruggles, Marquette A. Healy and C. J. Schmelzer Enjoying the Briny Deep.

cisco Bound" is the watchword of the association for the coming year.

The Lone Star State was particularly well represented at the convention this year, and the showing should convince the trade of the interest that the Texans are taking in the talking machine business. Those who registered included G. G. Neville,



Four Long-Horns from Texas.

Left to right: Lester Burchfield, Sanger Bros., Dallas; W. E. Parker, Talking Machine Co., of Texas, Austin; G. G. Neville, W. G. Walz Co., El Paso and Fernando de Arredondo, Thos. Goggan & Bros., San Antonio.

with the W. G. Walz Co., El Paso; Elihu A. Sanger and Lester Burchfield, of Sanger Bros., Dallas; F. De Arredondo, with Thomas Goggan & Bro., San Antonio, and W. E. Parker, with the Talking Machine Co., of Austin, Tex. All the Texans were



S. O. Wade and Mrs. Wade Watching the Sights at Atlantic City.

enthusiastic over the conditions and the outlook in their State, with its immense territory and constantly increasing growing population.

Among the officials and representatives of the Victor Co. who attended the convention or looked after the comfort of the visiting jobbers in Philadelphia, were Louis

F. Geissler, general manager; Charles K. Haddon, vice-president and treasurer; Walter J. Staats, comptroller; Belford G. Royal; Henry C. Brown, advertising manager; Frank K. Dolbeer, credit manager; W. B. Fulghum; George D. Ornstein, manager of salesmen; Ernest John, C. K. Bennett, E. E. Hipple, Jr.; H. A. Beach, C. H.

(Continued on page 41.)



Khaki Moving Cover Showing How Two Machines May Be Carried With Ease By a Single Messenger.

The Lansing Khaki Covers can be so easily adjusted that there is a large saving in time over the ordinary method, which, of course, means money as well.

The durability of these covers will be apparent to all. The service which they will render with reasonable care will be long, no matter how hard the usage to which they are exposed. With the Lansing Cover the machine is effectually protected from wet and cold weather, dust, scratches, bruises, finger prints, etc., which makes possible the delivery, of machines in the homes of purchasers in as perfect condition as when taken from the warerooms, thereby pleasing the customer.

It has four sides and a top especially for lettering.

No other covering is necessary, hence a large saving is made in time and material that would otherwise be used—also in expense of repairing and repolishing.

The manufacturer has such confidence in this product, and its aid to talking machine men everywhere, that he will send these covers on approval to interested parties. Covers so ordered may be returned at once to the factory if not found satisfactory.

The fullest information given concerning prices upon application.

The Lansing Khaki Moving Cover

Did You See It at the Convention of Talking Machine Jobbers at Atlantic City?

All Who Examined This Special Creation Were Quick To See Its Dollar Saving Power and Dollar Earning Power To Their Business.

The Lansing device is not only unique and original in every essential, but it provides talking machine dealers with a device which simplifies the delivery of talking machines and saves the cabinets from injuries which might come through careless handling in the way of varnish scratches and bruises.

A word of description in this connection: The outside of the Lansing Moving Cover is made of Government Khaki and the inside lining of cotton flannel. Four thicknesses of heavy felt are used for interlining, and all of these are firmly quilted in order to provide uniform thickness and durability. The large coverings have heavy straps passing underneath the machine terminating in handles half way up the sides, which are held closed in by heavy horizontal stays. This distributes the weight entirely upon the straps, there being no weight whatever upon either the machine or the cover.

These covers are made to fit all of the different talking machine models, and they effectually protect against scratches or other damage in transit, and the covers have been found invaluable in making deliveries.

A description of this product hardly suffices to convey to the mind of the reader just what it means to talking machine men. It saves much time in preparing machines for local delivery, and it prevents them from receiving any damage in transit through scratches or bruises. It saves money in doing completely away with paper and all wrapping material.



Arrangement of Straps on Khaki Moving Cover Showing a Practical Demonstration of Use of Straps Going Upstairs.



Lansing Khaki Moving Cover. Showing Ease of Adjustment.

E. H. LANSING

Manufacturer

611 Washington St.

Boston, Mass.

CONVENTION SNAP-SHOTS AND IMPRESSIONS—(Continued from page 39).

North, Thomas F. Green, Howard Shartle, Jas. E. Corneal, B. M. De Cou and others. Will Oakland, Steve Porter and several other recording artists were present at the banquet.

Through the efforts of L. C. Wiswell, chairman of the arrangements committee, a number of the Western distributors assembled in Chicago and



L. C. Wiswell.

came to the conventions in a body, leaving Chicago on a special car attached to the Manhattan Limited of the Pennsylvania Road on Saturday morning and arriving in Atlantic City on Sunday morning. The party included C. J. Schmelzer, Kansas City, Mo.; A. A. Trostler, Kansas City, Mo.; L. Burchfield, Dallas, Tex.; A. Hospe, Omaha, Neb.; G. E. Mickel, Omaha, Neb.; B. J. Pierce, Kansas City, Mo.; W. H. Reynolds, Mobile, Ala.; E. C. Rauth, St. Louis, Mo.; Geo. Mairs, St. Paul, Minn.; Fred. Seimon, Chicago, Ill.; Mr. and Mrs. S. O. Wade, Chicago, Ill.; J. E. Meagher, Chicago, Ill.; Robt. Fenton, Chicago, Ill.; Fred. Putnam, Peoria, Ill.; L. C. Wiswell, Chicago, Ill. At Pittsburgh the party was joined by J. C. Roush, president of the association; Perry B. Whitsit, F. C. Bruce and T. H. Towell.

The trip was a thorough success in every way.



Putting the "O. K." on the Landay Bros.

James B. Landay (left), Max Landay (right), O. K. Houck, (center).

though some of those on the train arrived a trifle red-eyed from lack of sleep. The car was well stocked with the materials essential to keeping dust and cinders out of the throat and the time-tried prescriptions were in considerable demand. Playing cards and swapping drummers' yarns served to pass the time pleasantly.

When Mr. Wiswell's small son placed a package of "sparklers" in his grip to insure his daddy enjoying a pleasant July Fourth celebration, the little fellow did not realize the trouble he was stirring up. A member of the Chicago party, who shall be nameless for this occasion, retired early on the train and was deep in the arms of Morpheus when Lester Burchfield lit a sparkler and held it in the berth. The slumbering one awoke to see the berth filled with fiery stars, and yelled "Fire!" and reached for the emergency cord simultaneously. It was some time before the atmosphere of the car got back to normal.

James and Max Landay, the Landay Bros. of New York, for the first time attended the convention together and mingled with the crowd on every occasion. The convention was somewhat new to James Landay, but Max took his brother over the ropes at a fast clip and saw to it that there was no lonesomeness.

Victor H. Rapke, the former jobber, who was elected mascot of the association some years ago,



Victor H. Rapke in Argumentative Mood.

was very much on hand at Atlantic City and was full of information regarding the developments of the trade and how things are and should be done. Mr. Rapke, who is at present in the automobile business, is shown in the accompanying snapshot just settling a discussion regarding conditions in some of the horn factories of days long past. Everybody knows Victor, 'cause he doesn't hide his light under a bushel.

A goodly group of travel-stained conventioners held a "death watch" in the hotel parlors until midnight Sunday when, it then being Monday, the thirst parlors could open for a short time. At the stroke the crowd hustled out, only to discover that a party who had been sitting on the curb, waiting, had gotten the first table.

One of the most enthusiastic of the conventioners



Autos Ready to Leave Hotel for Country Club.

was L. S. Sherman, who had never met with the talking machine men before. Mr. Sherman was not only impressed with the harmony existing in the association ranks, but was particularly interested in



Group of Ladies Ready for Auto Trip. Photo by Prince.

the exhibition of the Victor Co. and the abundant information regarding manufacturing and selling problems supplied to the jobbers by the department heads and other members of the Victor organization. Mr. Sherman stated that, though he had been in the talking machine business since its infancy, he had gained much new and valuable knowledge of trade matters during his stay at the convention.

Only two of the jobbers traveled to the convention city in their automobiles, they being Emanuel



Mr. and Mrs. Emanuel Blout on the Boardwalk.

Blout, of New York City, who was accompanied by Mrs. Blout and the two Misses B'out; and Benj. Switky, of New York, who brought down with him Mr. and Mrs. J. H. Dodin and George W. Morgan. Both gentlemen loaned their cars to the committee for taking the ladies on the auto trip to the Country Club on Monday.

Lester Burchfield as usual came to the convention with so many new tricks in his trunk there was hardly room for his clothes. A musical clothes brush was only one of a number of nerve destroyers.

E. N. Upshaw, of the Elyea-Austell Co., Atlanta, is possessed of a "Rebel yell" which was probably handed down from the last generation, but has

(Continued on page 44.)

Another Talk Conve

TO BE held right here and now.
You are the membership, the

Just one topic for discussion:
out into more general merchandising a

Well, what about it?

Was any question of equal importa
Atlantic City?

You are a merchant, dealing in m
yourself down to a restricted one-line
people want if there is money in it.

Suppose you had been "in" on the three-months
the dance furor first and Columbia dealers were makin
fore any one else could touch it.

Somebody is buying a huge and increasing oupu
ing no other make of records, and thousands of the b
you a good clear slant on how near home those goo m

People who come in through your door and inst
those others who have your business sized up from re
as well have as not. Those people won't come in a d
precisely what they have been doing right along, gcs
of talking machine product, and to them that's as god

There are so many things to tell you about re
stricted line that we would like to be asked to lay tem

So we take this occasion to suggest that you w

Geo. W. Lye,

Columbia Grapho

Woolworth Bu



ng Machine

ntion

s, and all the committees.

the talking machine dealer broaden
handle all lines that are in demand?"

to *you* brought up for discussion at

l instruments. You should not hold
specialty trade, but carry whatever the

bia lead on dance records for instance? We saw
policy turn-over every week for a good long time be-

olumbia machines and records—some of them buy-
Columbia records certainly half of the time. Have
spending customers are?

olumbia records are really nothing to judge by. It's
e, whom you never see, whose trade you might just
force you to supply them—they will continue to do
ere else. They know that you handle only one line
directory of where *not* to buy.

reasons for handling a general line instead of a re-
e you.

certain live information to

ral Manager

hone Company

, New York



CONVENTION SNAP-SHOTS AND IMPRESSIONS—(Continued from page 41).

lost none of its force. Mr. Upshaw brought the yell with him to the convention and insisted upon letting it loose whenever the bands or orchestras played "Dixie," and which was very frequent. If the Upshaw yell had been with Lee, the late unpleasantness might have ended differently.

As though the sessions of the conventions and the entertainments in connection therewith did not furnish enough excitement, those visitors having rooms on the ocean side of the hotel were awakened on Tuesday morning by cries coming from the water, and saw a thrilling rescue of two drowning men by a trio of hotel porters before the regular lifeguards were on



Benj. Switky Always Spic and Span.



C. K. Bennett, of the Victor Co. Taking an Order for a Carload of Needles from G. A. Mairs, of W. J. Dyer & Bro., St. Paul.

duty. Several of the talking machine men also had unpleasant experiences with the heavy undertow, though not sufficiently serious to require rescuing by the guards.

Fernando De Arredondo was particularly interested in the convention and things generally in the East. Mr. Arredondo is a native of San Antonio and until his trip to Atlantic City had never been beyond the borders of his native State, and found much during the journey to demand his attention.

One of the features of the ball game that appealed particularly to many of the visitors was the parade of the "bleacherites" after the game. The crowd from the open stand crossing the



View Across the Ball Field After the Game Closed.

field in the sun gave an excellent idea of what constitutes a crowd of fans. The accompanying snapshot was taken from the Victor Co.'s section of the stand while the guests were waiting for the crowd to pass out before proceeding to the automobiles waiting for them.

Charles Bobzin, of the Silas Pearsall Co., New

York, one of the veterans of the trade, was early on the ground greeting old friends and exchanging reminiscences of the former days when the Victor dog was a pup. Mr. Bobzin is full of information regarding trade conditions that is based on a long and broad experience.

To all intents and purposes James F. Bowers' annual job as toastmaster at the banquets of the association will last just about as long as Mr.

Bowers is willing to favor the jobbers with extracts from his rich fund of wit and humor, a wit which has a distinctly Celtic touch to it and is therefore never lacking in point. One jobber dubbed Mr. Bowers the "toastmaster laureate" of the association which phrase describes his standing in perfection. Incidentally Mr. Bowers' ready wit and ability to put things clearly has saved more than one situation in the meeting room during business sessions.

THE EXHIBITS AT THE JOBBERS' CONVENTION.

There were a number of manufacturers of accessories, cabinets, needles, etc., who had exhibits in the various rooms of the Chalfonte and other hotels during the convention though an arrangement between the hotel, and the association barred exhibits in the public rooms and corridors as was formerly the case.

Among those who had displays at the Chalfonte was Clement Beecroft, of Philadelphia, representing the Long Cabinet Co. The various popular models of Long cabinets for the leading makes of machines were exhibited and the jobbers who were not already familiar with the quality of the Long cabinets were generally impressed. Mr. Beecroft also represented the well-known Bagshaw needles and other specialties at the convention.

J. T. Edling, head of the Velvaton Wood Needle Co., Kansas City, Mo., was early on the ground with samples of the Velvaton needles for the purpose of demonstrating them before the jobbers. Mr. Edling also showed the process of manufacturing the needles from the time the lumber was first sawn until the finished needle came from the hardening solution. It is the claim of the company that by giving the needle a quarter turn after each reproduction ten or more records may be played without changing the needle.

M. A. Carpell, representing the Herzog Art Furniture Co., was also on hand with a cabinet exhibit, which included a new style revolving cabinet.

M. B. Claussen, of the Masterphone Corporation, New York, was also on hand for the purpose of demonstrating the Masterphone for the benefit of those few jobbers not already familiar with the merits of this device in the improvement of tone.

KHAKI MOVING COVERS

For Talking Machines Displayed by E. H. Lansing During Convention Attract Attention—A Genuine Convenience.

Among the prominent exhibits at Atlantic City during the jobbers' convention was the display of E. H. Lansing, 611 Washington street, Boston, Mass., manufacturer of khaki moving covers for talking machines, which are designed for the convenient and safe carriage of talking machines and other musical instruments. In the delivery of these instruments, it frequently happens that the highly polished surfaces of the cabinet work is scratched, which not only mars the appearance of the instrument but causes a repair bill that is liable to total more than the cost of one cover, to say nothing of the uncertainty of matching the damaged spot with the balance of the varnished surface. Lansing covers protect machines from rain, snow, dust, extreme cold or heat, as well as from scratches, bruises, finger prints and other damage.

Lansing khaki covers are made in two styles, one for the dealer and the other for home use, both of which are sold under the unconditional guarantee of absolute satisfaction or money refunded.

The outside of Lansing covers is made of Government khaki and the inside lining of cotton flannel. Four thicknesses of heavy felt are used for interlining and all is firmly quilted to keep it of uniform thickness and durability. The straps are heavy (three-ply) webbing and are not riveted to the cover but held in place by tapes. Patent buckles are used. The foregoing covers the description of the covers designed for commercial

purposes while the home covers are made of cotton flannel, print, felt, rubber, mackintosh, etc., the prices of the latter running from 50 cents to \$3.

Mr. Lansing was personally in charge of his Atlantic City display, and the booth was visited by not alone the delegates but by many other people, to whom the value of the Lansing cover was apparent without much discussion on his part, and he took a number of orders for all the styles of covers that he manufactures.

OUR
**VICTOR
SERVICE**
IS SAFE
PROMPT
EFFICIENT

We safeguard our patrons' every interest. Try us next time. Mail orders receive prompt attention.

ELMIRA ARMS CO.
117 MAIN ST., ELMIRA, N. Y.

SEE HOW THE JOBBERS IN THE WORLD CAN SUPPLY YOUR WANTS.



Columbia Double-Disc Records A-5542, A-5531, A-5549, A-5494—a few One-steps and Hesitations that a majority of Columbia dealers are finding hard to keep in stock.



(Write for "Music Money," a book "full of meat" for those dealers interested in quick and frequent turnover of capital.)

**Columbia Graphophone Company
Woolworth Building, New York**

NEW EDISON ARTISTS

To Make Their Debut in the Edison Blue Amberol List for September.

Three prominent artists will make their debut in the Thomas A. Edison Blue Amberol list for September. The trio is headed by Alessandro Liberatti, the distinguished bandmaster and cornet



A. Liberatti.



F. Martin



S. Gardner.

soloist, who has been touring the United States with great success for the past thirty-six years.

In the September list Liberatti's Band is represented by "The March of the Inland Tribes," "La Mia Speranza Waltz" and "The Suffragettes March." These compositions of Liberatti are played by his band with a finish and charm that is inspiring. The instrumentation of the band is admirable for recording purposes.

Frederic Martin, who will make his debut in September with the Edison talent, is a basso of

international fame, having appeared with all the leading orchestras and musical festivals throughout the country. He has a large and noble voice, rich in quality and well controlled, notable, moreover, for a wide range. Mr. Martin, who is basso of the Fifth Avenue Presbyterian Church Quartet, sings that notable song of Schubert's, "The Wanderer."

Last but not least comes Samuel Gardner, a clever young violinist, who made his debut last year in New York. He is a pupil of Franz Kneisel, and one in whom he has taken a great interest. Although born in Russia, he is essentially an American product. Comparatively a youngster, he plays like a veteran, as is evidenced in his rendition of Dvorak's exceedingly popular "Humoresque." There is authority, charm and perfection in his playing that will make his records popular.

EX-GOVERNOR DOUGLAS A BUYER.

Among the Victor sales to noted people by the Oliver Ditson Co., Boston, Mass., was a machine to Ex-Gov. Wm. L. Douglas, who, in addition to his public life, is a well-known shoe manufacturer.

TALKING MACHINE JOBBERS WHO ADVERTISE IN THE WORLD ARE LIVE ONES, TRY THEM!

FURNISHES FUNERAL MUSIC.

(Special to The Talking Machine World.)

NEWTON, LA., July 9.—An Edison disc phonograph furnished the music at a funeral in this city last week. The music had been overlooked until next to the last minute and the local talent in this town was both mediocre and scarce. Accordingly an Edison disc phonograph was used to play "Lead Kindly Light," "In the Sweet Bye and Bye," and "One Sweetly So'lemn Thought." The substitution was pronounced highly appropriate by the mourners.

TO HANDLE COLUMBIA LINE.

The Columbia Graphophone Co. closed arrangements this week with the New Jersey Piano Co., Plainfield, N. J. whereby this well-known piano concern will handle a complete line of Columbia products and feature them in an extensive publicity and selling campaign.

A TRIO OF NOTABLES.

Edward D. Easton, president of the Columbia Graphophone Co., accompanied by H. L. Willson, assistant general manager of the company, and Senator William E. Johnson, a prominent captain of industry, sailed recently on the steamer "Imperator" for a four weeks' trip abroad, visiting England and Continental Europe.

C. E. GOODWIN TO EUROPE.

C. E. Goodwin, of The Phonograph Co., Chicago, is visiting Europe on his annual vacation, expecting to return in about one month.

The Silas E. Pearsall Company

Were first in the field as

Jobbers of Victor Products to believe in the Supremacy of the Victor

and are referred to as the house where VICTOR GOODS may be found when a shortage exists. Many dealers have been placed upon our books during the past strenuous six months.

Come in under our wing. We need you to help maintain Our Standard.

It will pay you to enter into correspondence.

SILAS E. PEARSALL COMPANY

VICTOR DISTRIBUTORS

18 West Forty-Sixth Street

(Near Fifth Avenue)

NEW YORK

We Specialize Foreign Records, Record Cabinets, Needles, Needle Cutters, Auto-stops, Corrugated Board Containers and Envelopes.

OUR MOTTO
Correctness and Despatch.

A Practical RECORD System FOR DEALERS

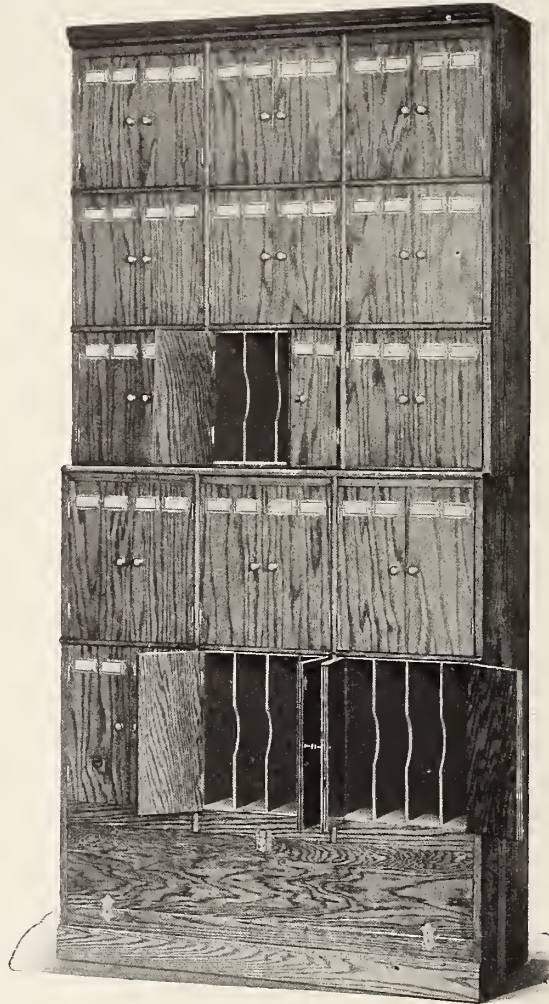

The New Tamaco Stock Record Rack

Capacity 1000 Records

Price All Oak Finishes, \$27.50
Mahogany and White Enamel, \$31.50

Write for circular describing this record rack—it has new features—you'll be interested.

OUR new Record Stock System Pamphlet is ready. This system shows you which are the big, live sellers in your record stock—shows you just how many you have sold during the past month or year of any number, enables you to order without fear of overstocking—prevents an accumulation of slow selling records, and the loss of profits by not having records your customer wants. It shows your exact investment and turnover—is a perpetual inventory and automatically reorders—is simple and inexpensive to install and operate.

You'll be interested in our Summer Sales Ideas, too.

THE TALKING MACHINE COMPANY

12 North Michigan Avenue : : : : : Chicago, Illinois

FROM OUR CHICAGO HEADQUARTERS

E. P. VAN HARLINGEN, Manager
HENRY S. KINGWILL, Associate

World Office
Consumers' Bldg., 220 South State St., Chicago
Telephone: Wabash 5774

(Special to The Talking Machine World.)

CHICAGO, ILL., July 9.—The talking machine men are not complaining about dull times, and everywhere throughout this specially favored section of the country crop reports are excellent, and they tend to give a new life and impetus to business.

A number of our well-known local talking machine men have been absent attending the national convention of Talking Machine Jobbers at Atlantic City. J. F. Bowers has never missed a meeting since he was instrumental in founding the organization at Buffalo, and this year Marquette Healy has paid his first visit to the national meet of talking machine men, and no doubt he will be impressed with what he sees and hears at Atlantic City.

Edward H. Uhl, local manager of the Wurlitzer interests, and Mr. Simon, as well as S. O. Wade and Mrs. Wade, journeyed down to enjoy the cooling breezes of the favorite Eastern resort during convention week.

While chatting with the talking machine men locally, one is more and more convinced that the talking machine trade is one of the very few which is enjoying prosperity, and of course with the big crops which we seem reasonably sure of securing now, there will be a greater demand than ever before upon the manufacturing resources of the industry.

The talking machine trade has grown some since its inception and is continuing to go forward by leaps and bounds. The conditions surrounding it were never better than to-day, and one delightful thing about the trade is that there has been no price cutting and slashing. Pick up the papers containing the advertisements. They are always of the appealing, educational character rather than of price cutting. How much better it would be if some of these methods were engrafted upon the piano business. It would be refreshing indeed to turn to papers containing announcements of pianos and find that the intent of the advertiser was to interest purchasers on the basis of supplying them with useful, necessary and valuable home accessories rather than to catch them on a price baiting proposition.

Certainly, there are arguments everywhere for standardized prices and the fixed price principle must commend itself to merchants everywhere, because it will do away with price haggling very materially.

Safeguarding Deferred Payment Contracts.

The attention of the Chicago Association of Credit Men has been called to the necessity of some legal action to safeguard merchandise sold on deferred payment contracts. The party pushing the move is the Moneyweight Scale Co. It sells its scales on deferred monthly payments and finds that the only protection it has against the attaching creditor or a court action is the filing of a chattel mortgage. Of course, when a chattel mortgage is given it must be by the owner of the article, so that it becomes necessary, to have complete protection, to pass the ownership with the first payment and then take back a chattel mortgage for the deferred payments. The making and recording of the mortgage is expensive, unnecessarily so, the makers of the scale contend. They believe that the same end would be attained and even greater security afforded the seller if a law were placed on the statute books by which the contract of sale could be made a matter of record.

This matter is one that deeply interests the music trade of Illinois, where a majority of the instruments are sold on contracts of sale providing for payments extending through a term of many months, during which almost anything is likely to happen. The piano dealers have tried to secure such a law several times, and have also tried to secure a modification of the chattel mortgage act which would permit of their being acknowledged before a notary instead of going before the municipal court. In both cases the attempt was futile.

A law similar to that asked for in Illinois is in force in New York State, and there seems no good reason why the same rule should not prevail in this State. As it is, the seller of a piano or talking machine, unless he goes to the trouble and expense of taking a chattel mortgage and recording it, is at the mercy of an insolvent buyer. The bankruptcy courts positively refuse to recognize these sales, and the contract has been declared of no effect as against an innocent purchaser of the instrument so that some such action as urged by the Moneyweight Scale Co. would be very welcome; and now that the music dealers are reinforced by lines other than their own they may be able to secure some action. The Credit Men's Association has the matter before the legislative committee, of which Mr. Whitlock, of Belding Bros. Co., is the chairman.

At the W. W. Kimball Co. Mr. Blanchard said: "You can put this company down as heartily in favor of any legitimate effort to accomplish the above reform in relation to the recording of contracts of sale. I, personally, worked for this object in previous attempts and am aware of the obstacles that the measure had to pass in the Legislature. It may be that present conditions will make it easier to do something. At any rate we should try and have the united support of all parties who will be benefited by the proposed change in the law. It is useless for individuals to try and accomplish anything."

At Lyon & Healy's the credit department was very strongly in favor of some such move or any move that would give safety. "The bankruptcy courts absolutely refuse to allow claims under a contract, and all we can do is file our claim with the other creditors for the unpaid balance and see the piano or Victrola that is really our property included in the assets of the bankrupt. We heartily hope that the attempt will succeed."

Mr. Whitlock, chairman of the legislative committee of the Chicago Association of Credit Men, is receiving co-operation of a number of members of the music trade throughout the State. Those wishing to co-operate are invited to communicate with him.

Big Columbia Record Sales.

Charles F. Baer, local manager of the Columbia Graphophone Co., reports that the past month has shown an excellent sales record with a particularly heavy business in the record department. Sales of the Columbia records have been mounting steadily in the past thirty days and have shown what a wonderful impetus the liberal Columbia advertising machine has created. Sales of the medium-priced machines for use in summer homes are also marked, and in this the Columbia advertising department must also be thanked. Mr. Baer returned to his office from a three weeks' motor trip to the East in excellent health and well prepared for a heavy fall business.

W. C. Fuhri, district manager of the Columbia interests, is on a three weeks' vacation at Spring Lake, Mich., and is enjoying boating and fishing.

A. J. Tucker, who is in charge of the wholesale order department, is confined to his home by a serious illness that his physicians fear may develop into typhoid fever.

Increases Capital Stock.

The Phonograph Co., local Edison jobber, has
(Continued on page 49.)

THE WADE—THE PRACTICAL—THE WADE Fibre Needle Cutter

The WADE embodies the right principle, worked out through long experience. It is simple, durable and accurate. It trims the needle at an angle resulting in the best tone. The WADE cutters are made of the best steel and are absolutely guaranteed.

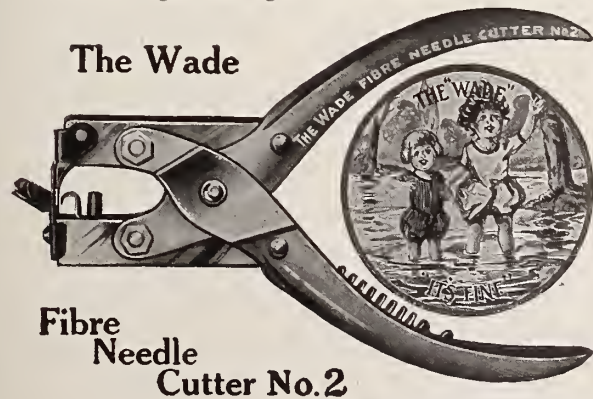

The Wade

Fibre
Needle
Cutter No. 2

The WADE is the most economical cutter. It has a self-acting stop, which prevents waste and enables one to get from 12 to 15 perfect points. No. 2 has a double action, making it especially easy to operate and affording the most powerful cut of any tool made. No. 1 is a very popular cutter which has given excellent service.

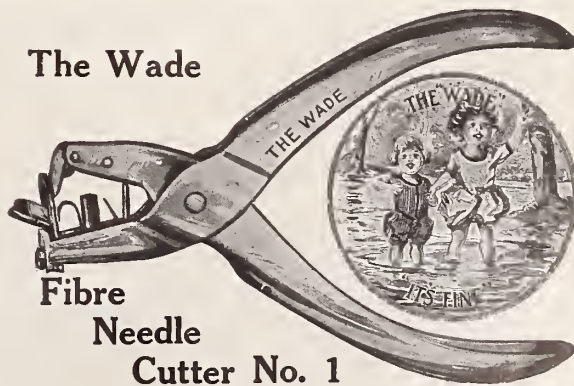

The Wade

Fibre
Needle
Cutter No. 1

RETAIL PRICES—No. 1, \$1.50; No. 2, \$2.00

Order from your regular Distributor—we sell to Jobbers only

WADE & WADE,

3807 Lake Ave.
PHONE, DOUGLAS 8108
CHICAGO, ILL.

Satisfy Your Customers!



Send Your Record Orders to
us. Our Record Stock is now

95% COMPLETE

Lyon & Healy

CHICAGO

FROM OUR CHICAGO HEADQUARTERS—(Continued from page 47).

recorded an increase of the capital stock from \$50,000 to \$100,000. The increase was necessitated because of the greatly enlarged business that the company is doing.

Personals and Visitors.

Some recent visitors to the local trade were F. R. Pancoast, Hastings, Ill.; Herman Marks, Emmetsburg, Ia.; C. B. Tousley, Fort Atkinson, Wis., and W. H. Hale, manager of the Victor department of G. W. Wheelock & Co., South Bend, Ind.

Other talking machine men visiting the Great Central Market were H. G. Power, of the Taylor Carpet Co., Indianapolis, Ind.; L. C. Peck, of the Peck Hardware Co., Berlin, Wis., and Mrs. Weise, of Bradford Weise & Co., of Waverly, Ill.

Mr. and Mrs. Fulton De Forest spent a part of their honeymoon at Chicago during the past month and called at the offices of the Talking Machine Co.

Guy Miller, T. J. Miller & Sons, piano and talking machine dealers of Dixon, Ill., was a visitor to the Lyon & Healy offices this week.

E. S. Wilson, of the Wilson Music House, was also a caller at the big Wabash avenue institution, motoring in from Oshkosh, Wis., where his business is located.

George Israel, formerly buyer of talking machine department of Hillman's, has taken charge of the same department at Rothschild's succeeding Harry Solomon, who now has charge of other departments. Mr. Price, formerly of Grand Rapids and Detroit, Mich., has been selected to take direct charge of the talker department.

J. Stanislanis, Thirty-second and Halsted streets, prominent Lithuanian music dealer, has just placed a large order for Victor goods and will cater chiefly to the Lithuanian trade.

Mr. Davies, manager talking machine department of John Taylor & Sons, Cleveland, O., was in Chicago during the month. His firm is making

Albert M. Mansfield, Eastern representative for Lyon & Healy, was a recent visitor to Chicago.

George C. Jewel, Rhinelander, Wis., was a visiting dealer this month.

S. M. Ladd, of Morrison, Ill., and John Dahlin, St. Charles, Ill., were Edison dealers in Chicago recently.

A. D. Wayne, retail manager of the Edison Co., is on a vacation at Fox Lake, Ill.

W. C. Motershead, assistant advertising manager of Lyon & Healy, is spending a two weeks' vacation at one of the Wisconsin lakes.

Edmiston's Ingenuity.

H. E. Edmiston, retail manager of the F. G. Smith Piano Co., was seized with a brilliant idea the other day and proceeded to put in into execution. A Columbia Grafonola sign representing a stage where a young man and a pretty girl are dancing to the music of the Grafonola was placed in the window. The sign was not intended to be an illuminated one, but Mr. Edmiston, in a few minutes, rigged up an electric lighting arrangement which gave the sign the most realistic appearance and which, in the late hours of

the night, stood out in the Wabash avenue darkness like a cameo. As late as 11 o'clock, passers-by were stopping to admire the display and reading the prices of the various instruments in the window.

Reasons for His Faith.

Arthur Soudek, manager of the American Klingsor Works, reports that dealers all over the country are preparing for a big fall business. Mr. Soudek said to The World: "I base my belief on the big demand we are receiving for our needles, and when calls for such an accessory come in so heavily at this time of year it would seem that the dealers themselves believe that 1914 and 1915 will break all records. The remarkable response to our announcement in The World last month has satisfied me that there is a big demand for needles suited to the requirements of the different kinds of records. The fact that the Klingsor needles can be used with either the Victor, the Edison or the Columbia machines is another point in favor of the dealer who handles our product as every owner of a machine, no matter what kind, is a prospect."

HOW LYON & HEALY UTILIZE WINDOW DISPLAY SPACE.

Window Trim Connecting Vacation Season with the Victrola Which Has Won High Praise—
Enjoyment of Camping Enhanced by Music—Suggestions for Dealer with Small Window.

(Special to The Talking Machine World.)

CHICAGO, ILL., July 9.—About this time of the year thousands of city dwellers, both business men and those not so busy, are thinking of the delights of the North woods, are overhauling their camp equipment, replacing that which has served its time, eliminating those articles which have been proven unnecessary and adding those new devices that experience has proven will be of value and add to the pleasure of the trip.

Aware of this fact, Lyon & Healy have so deco-

well-pitched tent beside one of those clear Northern brooks, the backlog glowing and the fire blazing fitfully, the clear, crisp air fragrant with the odor of the forests and through the trees the stars glowing and sparkling with the brilliancy peculiar to those Northern woods, and then think of listening under such conditions to Tito's Serenade or the sextet from Lucia or the voices of the great singers, with all the beauty and haunting melody of their greatest successes. Would this be a little bit of all right?



Clever Window Display Made by Lyon & Healy and Devoted to the Victrola, Which Is a Model in Every Respect.

extensive improvements in his department.

Otto F. Leidel, formerly at 875 Third street, Milwaukee, has opened a new and very commodious ground floor store at 881 Third street in that city. Mr. Leidel features the Columbia line.

Robert Fenton, of the Wilson Avenue Talking Machine Co., was one of those present at the jobbers' convention at Atlantic City.

J. E. Meagher, Lyon & Healy traveler in Wisconsin, was in the city for a short stay and reports excellent business prospects.

Archie Mathias, talking machine dealer of Minneapolis, passed through Chicago on his way to Pittsburgh and Columbus. Mr. Mathias made the trip of automobile.

Miss Steel, expert saleswoman of the W. W. Kimball forces, is taking advantage of the dull season to take a vacation.

Ellis B. Hansen, head window dresser for the Wurlitzer stores, suffered considerable anxiety recently because of the serious illness of his wife. Mrs. Hansen is now much better.

rated their great front display window that it suggests most emphatically the necessity of including in the outfit for this season is a portable Victrola. And could there be a better suggestion? Take a

The photo herewith will help you understand this window display. To the right of the scene is the tent. On a stump before the tent is the Vic-
(Continued on page 50.)

"KLINGSOR" Talking Machine NEEDLES
(MADE IN GERMANY)
ARE THE BEST ON THE MARKET
10 STYLES
Write for Samples and Prices to the
AMERICAN KLINGSOR WORKS
1316-18 North American Building CHICAGO

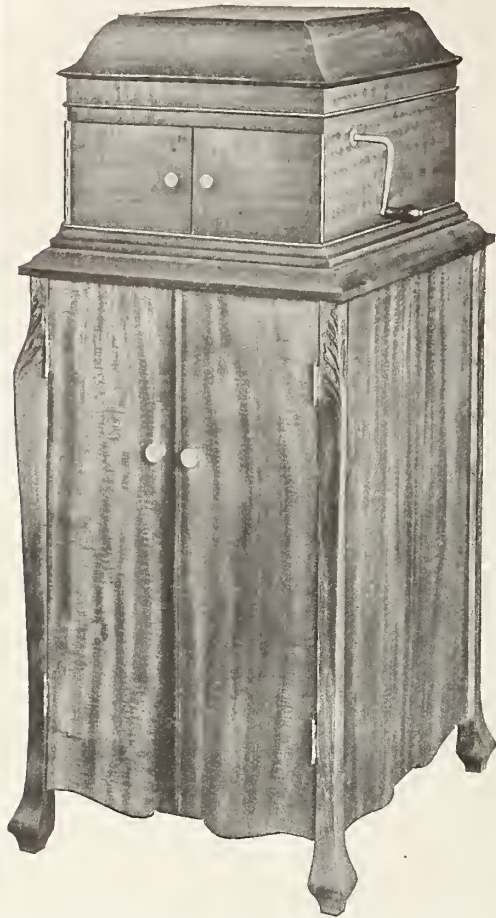

Salter's Patent Felt-Lined Shelf Cabinets
Are One of the Institutions of the
Industry. They Are Standard.

Better Make Your Cabinet Plans Now.

Don't let the Summer weather make you forget about Fall. Fall always means "rush" and "work." Summer is a good time to "think." Better plan to make this a big Salter Cabinet year—and place your orders *early*, because an ounce of preparation means a pound of profits.

We have Cabinets suited to

EDISON VICTOR and COLUMBIA Machines

They harmonize perfectly and are built so as to appear as one.

PLACE ORDERS EARLY.

SALTER MFG. CO.

339 North Oakley Boulevard

CHICAGO

trola, which commands the attention of the lady of the party. Her son restrains a dog, while to the left the man of the party is engaged in casting the fly. The background shows a Northern forest and the foreground is trimmed to represent a glade with a brook running through the foreground. This brook is the great attraction, and all the more because it contains a number of genuine brook trout from Michigan. The running water and the fish gliding about as if thoroughly at home in their environment make this the most interesting part of the scene to many spectators. This very attractive window picture is the work of W. J. Stewart, the window trimmer for Lyon & Healy. The large size of the display space in this window makes such work possible as this window and that of a year ago, when a full-sized electric launch was shown in motion, the party on board listening to the music of a Victrola.

There are few windows that could reproduce this set scene in its entirety, but there are many that could use motives from it. For example, that

portion of the scene showing the tent flap with the Victrola on a stump could be easily set. If the figures were not available the display would be suggestive and accomplish its purpose with only the tent and the Victrola. A still smaller window could be made from the idea by showing a tent directly across the back, making the end of the tent the background for the window. In the foreground could be placed a stump or log of wood, either being usually obtainable. On this place the Victrola. The floor of the window should be covered with some imitation of grass unless the window trimmer wishes to be very realistic, in which case a flooring of sod might be used. But in this case, as in most other cases of stage work, the imitation will be found to look more life-like than the real article. Trim the sides and top with branches of trees with plenty of green leaves, add anything that can be had in the shape of stuffed wild animals, and the trick is done.

A companion scene would be a representation

of a campfire at night, the fire burnt low and the figures shown lying down, wrapped in their blankets. No figures would really be needed, as the blankets could be arranged around piles of cloth or any substance that could be shaped to represent the outline of a human figure. The fire is easily represented by making a pile of partly burnt sticks and ashes against a backlog and under the pile placing an electric light with a red bulb. This can be made to glow from the center of the campfire in a very realistic fashion.

In all cases appropriate window cards would make the lesson plain by announcing that you could supply portable Victrolas to vacationists immediately or whenever wanted. Another card would call attention to your stock of records.



Write today for our new catalogue giving you rock bottom prices of our specialties.

Springs for any kind of Talking Machines

No doubt you will find it interesting.

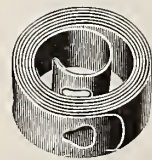

EMIL RIEDEL

Sächsische Sägen- u. Federstahlwaren-
Fabrik.

Chemnitz-Gablenz, P. O. Box 10, Germany

"Standard" Record Cleaner

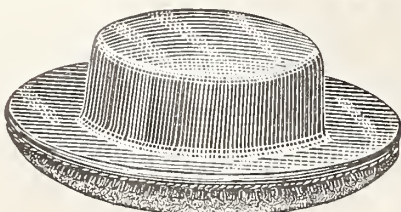

Price, 50 Cents, List
Patented June 2, 1914.

Send 10 cents in stamps for a sample cleaner. Write on your business letter head only. Place regular orders through your jobber.

STANDARD GRAMAPHONE APPLIANCE CO.

173 LAFAYETTE STREET,

NEW YORK

ARTISTIC AND ATTRACTIVE

Grips the record surface and
clings as if on rails.

Extended brush area cleans record
with one sweeping circuit.

YEAR'S CROPS OF RECORD VALUE.

Wheat, Corn, Oats, and Barley Worth the Stupendous Total of \$3,418,000,000—Promise 5,210,000,000 Bushels—Corn Crop Will Be a Larger One Than Usual, Government Reports Show, with Wheat a Bumper.

(Special to The Talking Machine World.)

WASHINGTON, D. C., July 8.—It will be joyful news to talking machine men and to all lines of trade that the four leading American cereal crops this year will cross the 5,000,000,000-bushel mark for the first time, which an approximate increase of \$200,000,000 in value over the average production and price for the last five years.

This staggering fact is contained in to-day's announcement by the Crop Reporting Board of the Department of Agriculture, forecasting the 1914 crop of wheat, corn, oats and barley. The forecast is based on the condition of the crops on July 1 as reported by the correspondents of the Government throughout the country.

The total crop of wheat, corn, barley and oats is expected to amount to 5,210,000,000 bushels. The five-year average production of these crops from 1909 to 1913 was 4,777,000,000 bushels. On the basis of the prices per bushel actually prevailing for these products on July 1 the estimated crop of wheat, corn, barley and oats this year will be worth \$3,418,000,000. On the basis of the average price for the last five years, \$3,218,000,000. The aggregate of these crops will be 433,000,000 bushels above the five-year average production.

The most valuable of these crops this year will be corn. The forecast is 2,868,000,000 bushels. The price of corn on July 1 was 75.5 cents a bushel, giving this crop an approximate value of \$2,151,000,000. The corn crop forecast is expected to exceed the five-year average by 160,000,000 bushels, and its value would correspondingly exceed the average annual value by \$283,000,000.

The forecast for winter wheat is 655,000,000 bushels, as compared with the annual average production for five years of 523,561,000 bushels. On the basis of the July 1 price of 76.9 cents a bushel, the crop will be worth \$503,695,000. This year's crop, on the basis of July 1 prices, will be worth only \$1,186,000 more than the annual average crop for the past five years.

The forecast for spring wheat is 275,000,000 bushels compared with an annual average of 239,819,000 bushels. This year's crop is expected to be worth about \$209,000,000 on the basis of the July 1 price of 76.9 cents a bushel.

The forecast for the oat crop is 1,201,000,000 bushels compared with an average production of 1,121,768,000 bushels a year during the last five years. At the July 1 price, 38.8 cents a bushel, this year's crop is expected to be worth \$456,380,000 as compared with \$504,450,000, which represents the average value of our oat crop for the last five years.

The forecast for barley is 211,000,000 bushels, as compared with 178,189,000 bushels on the average for five years. Barley was worth 47.5 cents a bushel on July 1. On that basis this year's crop will be worth \$99,170,000.

VICTROLA XVI. BEING FEATURED.

The Victor Talking Machine Co. sent out to its dealers this week an attractive summer folder featuring the Victrola XVI., which retails at \$200, as a machine particularly adaptable for dancing purposes. The company also mailed one of these folders to every summer hotel, yacht club and country club in the United States, in order that Victor dealers might reap the fullest possible benefits from this wide field of summer prospects.

H. A. Yerkes, manager of the Columbia Co.'s wholesale department, left last week for his summer vacation, which he will spend, as usual, at his old home in Washington, D. C.

TALKING MACHINE JOBBERS WHO ADVERTISE IN THE WORLD ARE LIVE ONES, TRY THEM!

WANTS BUSINESS PHONOGRAPHS.

The secretary of a prominent and progressive wholesale hardware house in the United Kingdom has manifested an interest in securing the agency for a phonographic machine for registering dictated correspondence, etc. No machine of this type have as yet made their appearance in the district, which has a population of over 1,000,000, and includes a number of good sized cities.

GREATEST OF EDUCATORS.

The talking machine is the greatest of all educators. It puts the artisan on speaking terms with the great composers. Humanity at large enjoy their masterpieces—a pleasure formerly confined to a favored few among professional musicians.

THE CORTELLA TALKING PICTURE CO.

(Special to The Talking Machine World.)

DOVER, DEL., July 7.—The Cortella Talking Picture Co. filed a certificate of incorporation this week with the Secretary of State to manufacture talking machines. The capital is given at \$300,000, and the incorporators are: A. Antonelli, W. T. Jones and H. L. Tourney, Philadelphia, Pa.

NEW NOISE PRODUCING MACHINE.

(Special to The Talking Machine World.)

CHEBOYGAN, MICH., July 7.—W. A. Rideout, Jr., is erecting a factory in which to manufacture a French noise producing machine to be used in theaters, imitating all sorts of noises and operated by a system of keys similar to those of a piano.



The "OGDEN" Record Sectional Unit and Filing System

IS A BIG SUCCESS!

Popular demand for this ideal record filing system has made it necessary to double the order with the factory. Illustration shows 10 section outfit (3,000 record capacity) all sections dust proof. Springs in each compartment, positively keeps records from warping.

GETS ANY RECORD IN 4 SECONDS

By the use of adjustable numerical signals Class (Color) Signals show you every similar record in stock. Without referring to catalog they indicate all Modern Dance records, Sacred Songs, etc. Also marks "slow-sellers" and "cut-outs" and prevents reordering. You can attach these signals 1 a second.

Each section has a capacity of 300 records. Finished to match your interior. Condenses stock, saving time and space and increases sales to pleased customers because of speedy record service, filed in a dignified system.

Finding, Filing and Re-ordering in one-half the usual time.

WRITE FOR DESCRIPTIVE BOOKLET,

naming your jobber. If he has secured the agency they can be shipped direct to you and billed by him.

Guaranteed as represented.

J. B. OGDEN, Lynchburg, Va.

"Puts Any Record in your hand in 4 seconds."



The number of talking machine dealers who restrict their business to one line of product alone is becoming less by every mail.



(Write for "Music Money," a book "full of meat" for those dealers interested in quick and frequent turnover of capital.)

**Columbia Graphophone Company
Woolworth Building, New York**

TO BOOM OUR FOREIGN TRADE.

New Downtown Club Organized, of Which James A. Farrell, President of United States Steel Corporation, Is President—To Develop Interest in Foreign Markets for American Goods—Prominent Men Interested.

For the accommodation of those engaged in or devoted to the development of American foreign trade a new downtown club has been organized in New York, to be known as India House.

At a recent meeting of a number of persons interested in this project, James A. Farrell, president of the United States Steel Corporation, was elected president; J. P. Grace, president of W. R. Grace & Co., treasurer, and Willard Straight, of J. P. Morgan & Co., secretary. Alba B. Johnson, president of the Baldwin Locomotive Works, Philadelphia; Edward N. Hurley, president of the Machine Co. of Chicago, and James R. Morse, of the American Trading Co., were elected vice-presidents.

The three-story building at No. 1 Hanover square, long occupied by W. R. Grace & Co., and formerly the New York Cotton Exchange, has been leased and is now being remodeled and decorated in harmony with the early traditions of the United States, which it is the purpose of the club to perpetuate. The membership will be national in character.

The organization committee consists of prominent men in New York, Philadelphia and Chicago. The organization will be promptly completed and it is expected that the club will be opened on November 15.

Mortimer D. Easton, son of President Edward D. Easton and advertising manager of the Dictaphone, arrived in New York recently on the steamer "Hamburg," accompanied by Mrs. Mortimer D. Easton. Mr. and Mrs. Easton had spent their honeymoon abroad, visiting during the past six weeks all the leading countries on the Continent. Mr. Easton also spent some time at the Dictaphone headquarters in London.

AN ENTHUSIASTIC LETTER.

The Boston branch of the Columbia Graphophone Co. received last week the following interesting letter from Don S. Ferguson, Beachmont, a prominent dancing instructor, who is the owner of a "Mignonette" machine and practically every dance record in the Columbia library:

"I received my graphophone in good condition and desire to thank you for the promptness in delivery. While acknowledging receipt of machine, I take pleasure in extending my appreciation for the splendid results obtained by the use of this instrument. There is nothing more worthy to receive than praise that originates from complete satisfaction. You are the receiver of my congratulations upon the product you are now marketing for dance records. My pupils and myself are unanimous in the opinion that they cannot be excelled. The tempo is perfect, the music inspiring, the tone inviting; three essentials for modern dancing. May our future relations continue in accordance. (Signed) Don S. Ferguson."

LONG CABINETS

Have Many Friends

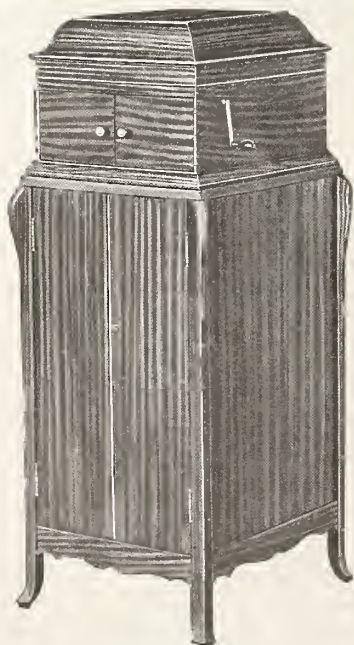

D65, D66, D67.
FOR VI., VIII., and IX. VICTROLAS.
Mahogany, Fumed Oak, G. O. and W. O.

A splendid line of well made, elegantly finished, Record and Player Roll Cabinets.

Prices and printed matter for the asking.

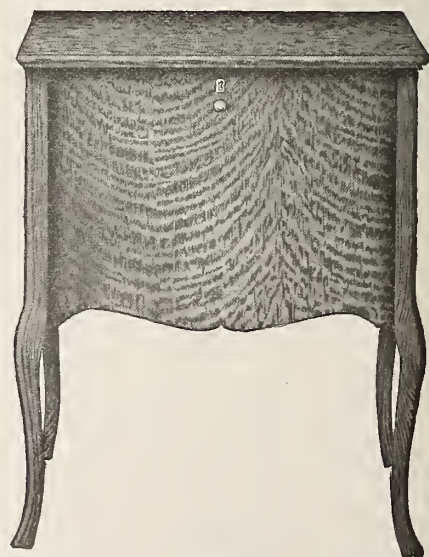

D32
Mahogany, Fumed Oak, G. O. and W. O.
Will Hold All Machines.

THE GEO. A. LONG CABINET CO., Hanover, Pa.

**Address CLEMENT BEECROFT, Sales Manager
309 W. Susquehanna Avenue, Philadelphia**



July 15th, 1914.

TO VICTOR DEALERS:

Between now and Fall, PROGRESSIVE VICTOR DEALERS will try and IMPROVE THEIR SERVICE and thus BE PREPARED for INCREASED BUSINESS during the coming season.

They will study the methods of others, SUCCESSFUL in their line, and will PROFIT accordingly.

PROGRESSIVE DEALERS are also realizing that they must study the METHODS OF ALL JOBBERS--TEST their SERVICE--be sure they have the EXPERIENCE, ORGANIZATION and CAPITAL to meet demands at ALL times.

The steady, healthy growth of this Company is the result of "BLACKMAN SERVICE" and it enters every transaction.

If you are not a "BLACKMAN DEALER", we extend you a cordial invitation to become one and IMPROVE YOUR SERVICE.

Yours truly,

BLACKMAN TALKING MACHINE CO.

J. Newcomb Blackman
President

CARRY LARGE STOCK OF GOODS

In Their Spacious Quarters at 351-353 Fourth Avenue, New York, C. Bruno & Son, Inc., Carry an Extensive Line of Victor Talking Machines and Records for Ready Shipment to Their Dealers in Territory They Control.

It is interesting to note the service extended by C. Bruno & Son, Inc., Victor distributors, 351-353 Fourth Avenue, New York. The accompanying



Showing Section of C. Bruno & Son, Inc., Record Stock Room.

illustration showing a portion of the record rooms gives an idea of the large stock carried. In addition to handling a large amount of merchandise, the company make a specialty of prompt shipment, it being their custom to forward goods on the same day that the order is received.

The record racks, the ends of which may be seen in the photograph showing a section of the record stock room, extend a considerable distance to the left as well as in the direction shown in the photograph, and these racks have a very large storage capacity. The records on the counter are being prepared for shipment to dealers. By maintaining an adequate stock it is possible to be of the greatest assistance to the dealer.

A visit to the rooms showing a part of the machine stock clearly indicates the volume of

goods constantly carried by this house. Not only is a large stock carried here, but additional storage facilities are secured in a warehouse in another section of the city. For the convenience of visiting dealers, the company maintains a display room on the Fourth Avenue and Twenty-sixth Street corner of their premises, where a complete line of Victor machines is on exhibition.

The Victor department of C. Bruno & Son, Inc., is under the direct charge of Charles F. Bruno, one of the officers of the corporation. Mr. Bruno devotes his entire time to the promotion of this particular department, the merchandising of Victor goods being not alone a hobby with him, but a feature of the business that has secured his interest for many years. Frequently dealers go to him for counsel and advice on business problems which always receive his careful attention.

The House of Bruno, which has been established for 80 years, the cornerstone of which was laid in 1834, is a monument to a successful business policy that is enjoyed by but few concerns. Its standing in the musical merchandise field is high.

One of the most forceful and helpful policies of this house is its exclusive wholesale plan, which never interferes with any retail sale of a merchant, wherever that merchant may be located.

NEW USE FOR RECORDS.

"I've found a new use for those phonograph records you bought last week and which cost such a lot of money," said his wife, according to the San Francisco Chronicle.

"How clever you are!" he exclaimed. "What is your latest?"

"In the first place," she began, "I hold a skein of wool over my arm, tie one end of the wool on a reel, place the reel on the graphophone pin and then start the machine. The wool is wound up in no time."

PROGRESSIVE JOBBERS ADVERTISE IN THE TALKING MACHINE WORLD. CONSULT THEIR ANNOUNCEMENTS.

The fond husband gasped in admiration.

"But that is not all," she continued. "To-morrow I shall place a little bath brick on one end of the records, start the gramophone, and so clean the knives."

He is still gasping.

INCORPORATED.

The Hutz Automatic Phonograph Co., of Brooklyn, N. Y., was incorporated this week with a capital stock of \$25,000 for the purpose of manufacturing and retailing musical instruments. Those interested are M. and H. Hutz and H. T. Reeb.

'Twould be great if people, when they want to air their views, could hang them on the clothesline in the backyard, as they do an old coat.

TALKING MACHINE JOBBERS WHO ADVERTISE IN THE WORLD ARE LIVE ONES, TRY THEM!

FOR SALE

For Sale—Very cheap to quick buyer, 60 Edison Firesides, 25 Standards, 10 Homes, all good order. 2,000 Blue Amberol Records run of catalogue. Address "F.," care The Talking Machine World, 373 Fourth Ave., New York City.

POSITION WANTED

Position Wanted—By live salesman, capable of being manager; 10 years' experience in talking machines and pianos; am at present manager of El Paso firm carrying the New Edison Disc. Address "C.," care The Talking Machine World, 373 Fourth Ave., New York City.

MANAGER WANTED

An experienced and capable phonograph man to qualify as manager of a jobbing and retail proposition. Edison Disc and Cylinder line. Address application to "Smith," care The Talking Machine World, 373 Fourth Ave., New York City.

MANAGER WANTED

Splendid opportunity for talking machine manager with one thousand dollars to invest in department, in one of the best department stores in Middle West. Policy of store requires investment for department managers. Address "J. 114," care The Talking Machine World, 220 So. State St., Chicago, Ill.

OPEN FOR ENGAGEMENT

Talking machine man with 15 years' experience, wholesale and retail, would like to connect with an appreciative concern; satisfactory references assured. Address "J. J. J.," care The Talking Machine World, 373 Fourth Ave., New York City.

WANTED

Manager for Victor-Victrola Department; state age and experience; all applications treated confidentially if desired. Address The Cable Co., 137 W. 4th St., Cincinnati, Ohio.

TRITON MOTORS

Spring may be replaced within a few seconds.

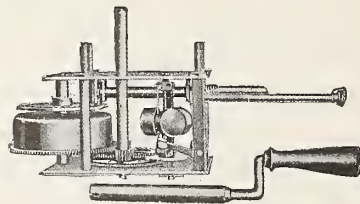

Noiseless Movements
Simplicity—Perfection

Can be wound while instrument is playing.

Quantity Price 75c., F. O. B. N. Y.

TRITON PHONOGRAPH CO.

41 UNION SQUARE, NEW YORK

Samples SENT UPON REQUEST \$1.25 EACH, CHECK WITH ORDER

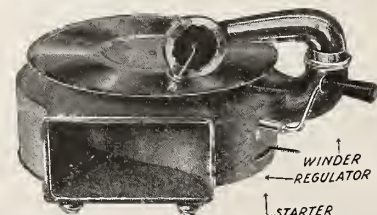

The Triton Phonograph

Retails at \$10.00

This machine gives you a chance to make a lot of money. Plays any needle disc record. Solidly built. Beautiful tone. Send for wholesale prices. Sample \$10.00.

TRADE CHANGE IN 50 YEARS.

Vast Growth of Exports Over Imports in the Last Half Century—Some Interesting Figures Set Forth That Are Worth Study.

The annual report on the commerce and navigation of the United States in the fiscal year 1913, just issued by the Bureau of Foreign and Domestic Commerce, reveals conditions of trade and industry in marked contrast with those prevailing in earlier years.

In a total trade of \$4,279,000,000 last year, exports exceeded imports by \$653,000,000, while at the middle of the last century, as shown by earlier reports of the series, imports were largely in excess of exports. Then imports of manufactures were more than five times the exports thereof, while in 1913 exports of manufactures were more than six times the imports of like classes. Meanwhile manufactured articles have largely replaced farm products and raw materials, except cotton, as the leading articles contributing to the export trade. Only in the carrying trade has the United States lost ground in the last half century. In 1850, for example, 70 per cent. of the foreign commerce was carried in American bottoms, while last year 80 per cent. was carried in foreign bottoms.

Additional interest attaches to the 1913 report, entitled "Commerce and Navigation of the United States," by reason of the fact that it contains the final statistical exhibit of the commerce handled at individual ports, many of which, under the reorganization effective July 1 last, lost their identity and are now included in rearranged customs districts bearing general titles, such as Massachusetts, Michigan and St. Lawrence. The continued relative advance in importance of the Southern ports is strikingly brought out in the report. While New York still holds a pre-eminent position, having handled \$2,000,000,000 of the \$4,500,000,000 worth of merchandise making up our foreign trade, Galveston has rapidly gained and is easily the second port of the country. Other Southern ports and certain of those on the Ca-

nadian border and Pacific Coast are also growing rapidly in commercial importance. New Orleans is the third port, Boston fourth, Philadelphia fifth, Baltimore sixth, San Francisco seventh, the Puget Sound ports eighth and Buffalo ninth, closely followed by Detroit.

Customs revenues last year aggregated \$313,000,000, and particulars regarding over 3,000 classes, varying in importance from such great groups as cotton laces, embroideries, etc., which paid \$22,000,000 in duties, to snowshoes, paying \$633,000,000.

NO INSIDE DISCOUNTS.

Printers' Ink Comments on a Recent Action of the Victor Talking Machine Co. and Tells Why It Came Into Being.

The July 9 issue of Printers' Ink contained an interesting article by one of the staff writers, relative to the new rule which the Victor Talking Machine Co. has inaugurated, whereby all discounts to employes and stockholders are abolished. This article reads as follows:

"Along with the increasing sentiment against the quantity discount has come a feeling that the granting of 'inside' discounts to employes, stockholders, etc., is likewise a danger to fair-trade principles. Especially among concerns which try to maintain resale prices, it is coming to be recognized that any variation from the principle of treating every buyer exactly alike as regards price is a mistake in policy.

"That the situation has become acute in some quarters may be surmised from a new ruling just announced by the Victor Talking Machine Co., to the effect that henceforth 'not an officer, director or stockholder of the Victor Co. can secure a Victor or a record at less than full list royalty.' Simultaneously with the announcement of this ruling, which is declared to 'conserve the real interests of our distributors and dealers,' there has gone forth from the general offices of the company at Camden a notice to all wholesalers and retailers handling

Victor goods that reads as follows: 'We shall construe it a violation of our license agreement if any discounts whatever from the full license royalty upon Victor machines, records or other patented appurtenances are given to any member of your firm, officer, director or stockholder of a corporation, or employe of either.'

Why the Victor Co. Changed Its Policy.

"Formerly the Victor Co. did not raise any objections to the trade giving complimentary discount to legitimate employes, and the Victor Co. followed this practice with the 6,000 workmen in its manufacturing plant. The circumstances which led to the present radical change of policy may not be without significance for advertisers and manufacturers who are marketing specialties of wide popular appeal. It has all come about from the fact that various department stores throughout the country took advantage of the Victor Co.'s leniency in this regard to inaugurate what practically amounted to a cut-price campaign. The offer of a ten per cent. discount was made openly in the pay envelopes of all the department-store employes, and the possibilities of this wholesale shaving of prices—there being 50,000 department-store employes in New York City alone—aroused the Victor Co. to action.

"The matter would be serious enough if the loss to manufacturers and distributors through the advantage taken of the ten per cent. discount were confined to legitimate employes and the relatives that they might endeavor to favor openly or surreptitiously. However, manufacturers who have studied the situation say that it has a yet more serious side in that employes have been tempted in not a few instances to split the discount with comparative strangers who desire to purchase the goods and who contract to buy them through an employe, in order to save a fraction of the list price—say five per cent., while the employe retains five per cent. for conducting the transaction."

PROGRESSIVE JOBBERS ADVERTISE IN THE TALKING MACHINE WORLD. CONSULT THEIR ANNOUNCEMENTS.

Flexible Star Needle



"One Plays Twelve"

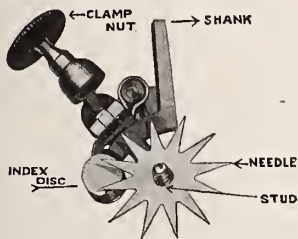

The complete attachment—simple, quick and easy to handle.

THE right hand illustration shows the Flexible Star Needle and Holder in proper position on a disc record. It can be easily applied to any sound-box having a screw fastening to hold the needle.

TO APPLY

To apply the needle holder, insert the shank into the needle opening in the same way as an ordinary pin and tighten the screw firmly.

TO CHANGE NEEDLES

The illustration at the left shows the clamp-nut open in position to change Star Needle. The needle is placed over stud as indicated. The clamp-nut is dropped down over stud and tightened firmly.

AFTER PLAYING

After playing a record to bring a new point into position, the crank-handle is turned one revolution.

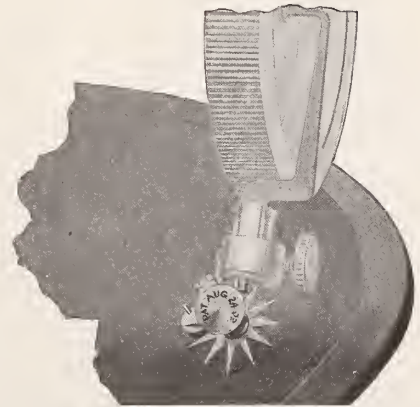

Price—Complete Set

Needle holder and 300 points... \$3.00
Extra points, package of 300... 1.00

Complete descriptive folder mailed on request.

FLEXIBLE STAR NEEDLE CO.
CLEVELAND, OHIO

701 Commercial Building
2056 East Fourth Street

REMODEL "TALKER" QUARTERS.

Rosenblatt Piano Co., Bristol, Tenn., Installs New Soundproof Booths and Makes Other Improvements of Importance.

(Special to The Talking Machine World.)

BRISTOL, TENN., July 6.—The Rosenblatt Piano Co., of this city, which handles the products of the Victor Talking Machine Co., has just completed a number of changes in its Victor department which greatly enhance the attractiveness and facilities of this division of its business. Oscar Simmons, well known in the local talking machine trade, is manager of the Victor business of the Rosenblatt Piano Co. and to date has achieved a well-deserved success.

Among the improvements introduced by the company in its Victor department is the construction of three sound-proof demonstration rooms for the convenience of its patrons. This is especially noteworthy as showing the rapid strides that the Victor products are achieving in the smaller cities of the South, in company with the larger trade centers. As recently as two years ago sound-proof demonstration rooms in a city the size of Bristol were practically unheard of, but to-day they can be found in small towns from coast to coast.

IMPORTANT TESTIMONIAL.

Another important addition to its valuable collection of testimonials on behalf of Columbia dance products was received the other day by the Columbia Co. from Morgan D. Stern, head of the modern dance society study bearing his name at Broadway and Fifty-seventh street, New York. Mr. Stern, who is prominent throughout the East as an authority on the present dances, writes as follows:

"Kindly place on record my order for an additional 'Dengozo' matchiche record. The perfect rhythm and beautiful tone which this record possesses, aside from its greater length and lower price, places it superior to any other matchiche record so far produced—in fact, all Columbia dance records embody the one important requirement toward perfection—namely, accurate time. The Columbia dance records are in continual use in all my studios, both in private and class instruction. For the latter purpose I consider them preferable to other musical instruments. Yours very truly, (Signed) Morgan D. Stern."

CHARTERED TO DO BUSINESS.

The M. G. H. Corporation has been chartered under the laws of New Jersey to engage in the phonograph business. The capital stock of the new concern is \$500,000 and the incorporators are J. T. Magee, B. McCall and A. J. Stobbart.

TO MAKE LOW PRICED MACHINE.

It is reported that a company is being organized in Chicago for the manufacture of a talking machine that will retail for from \$5 to \$10, and which is said by the promoters to be a remarkably serviceable instrument. Records will be made to fit it that are but a few inches in diameter.

When you get to the store in the morning be sure that you look and feel like work. If you don't feel that way there is something the matter.

SEE HOW THE JOBBERS IN THE WORLD CAN SUPPLY YOUR WANTS.

OUR SILENT SALESMAN ASSORTMENTS

A Place for Everything and Everything in Its Place

These Handsome Glass Show Cases

ABSOLUTELY FREE!

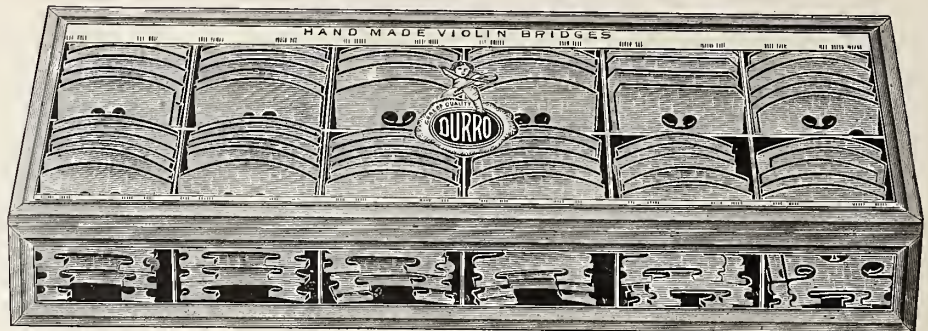

Size 5" x 12".

Contents of Bridge Assortment No. 1

1 doz. No. 705 Bridges.....	\$0.15	1 doz. No. 12 Bridges.....	\$1.20
1 " " 706 "25	1 " " 18 "	1.50
1 " " 708 "25	1 " " 1205 "15
1 " " 708½ "40	1 " " 1206 "25
1 " " 709 "50	1 " " 1305 "15
1 " " 11 "	1.00	1 " " 1306 "25

Sells for	-	-	-	-	-	-	-	-	\$20.40	\$6.05
Net Cost to You	-	-	-	-	-	-	-	-	\$6.05	
Your Net Profit	-	-	-	-	-	-	-	-	\$14.35	

Contents of Mandolin Pick Assortment No. 3

6 doz. No. 7 Picks.....	\$0.04	\$0.24	3 doz. No. 25 Picks.....	\$0.25	\$0.76
4 " " 7½ "04	.16	2 " " 31 "25	.50
1 gr. " 100 "50	3 " " 1 "20	.60
4 doz. B. & J. "10	.40	3 " " 51P "40	1.20
3 " No. 6 "20	.60	2 " " 10½ "35	.70
3 " " 8½ "22	.66	2 " " 46 "16	.32

Sells for	-	-	-	-	-	-	-	-	\$36.00	\$6.64
Net Cost to You	-	-	-	-	-	-	-	-	\$6.64	
Your Net Profit	-	-	-	-	-	-	-	-	\$29.36	

Contents of Tailpiece Assortment No. 4

½ doz. No. 710 Tailpieces....	\$0.75	\$0.38	½ doz. No. 100 Tailpieces...	\$3.00	\$1.50
½ " " 712 "	1.00	.50	¼ " " 710¾ "75	.19
½ " " 714 "	1.20	.60	¼ " " 710½ "75	.19
½ " " 176 "	2.50	1.25	24 pieces Tail Gut.....	.01	.24

Sells for	-	-	-	-	-	-	-	-	\$14.40	\$4.85
Net Cost to You	-	-	-	-	-	-	-	-	\$4.85	
Your Net Profit	-	-	-	-	-	-	-	-	\$9.55	

Contents of Peg and Mute Assortment No. 5

1 doz. No. 730 Pegs.....	\$0.36	½ doz. No. 746 Mutes.....	\$0.90
1 " " 731 "50	1 " " 743 "30
1 " " 1 "50	1 " " 745 "40
1 " " 2 "60	1 " " 755 "70
1 " " 444 "90	1 " " 748 "	1.40
½ " " 730¾ Size.....	\$0.36	1 " " 762 "	1.00
½ " " 730½ "36		

Sells for	-	-	-	-	-	-	-	-	\$21.70	\$7.92
Net Cost to You	-	-	-	-	-	-	-	-	\$7.92	
Your Net Profit	-	-	-	-	-	-	-	-	\$13.78	

And a Handsome Glass Show Case ABSOLUTELY FREE!

You Can Carry a Complete Line of Musical Sundries in a Space 20 Inches by 12 Inches, with an Average Profit of 200 to 250%.

BUEGELEISEN & JACOBSON

113-115 UNIVERSITY PL., NEW YORK

"DURRO, N. Y.," Will Reach Us



The Columbia automatic stop. The most accurate automatic stop made and the easiest to operate.

Gun Metal, \$2.00 list. Nickel Plated, \$2.50 list. Gold Plated, \$3.00 list.

May be adjusted to both Columbia and Victor disc machines.

Order from any Columbia Distributor.



The Columbia Grafonola "Mignonette"—\$100—has been designed and built with a view to providing the best quality for \$100 that this Company—or any other company—has ever produced, and it is proving itself all that.



(Write for "Music Money," a book "full of meat" for those dealers interested in quick and frequent turnover of capital.)

**Columbia Graphophone Company
Woolworth Building, New York**

PLEASED WITH TRADE PROSPECTS.

Indianapolis Surprised at Summer Activity—Cultivating Canoe Trade—Piano Houses Take on Victor Line—News of the Month.

(Special to The Talking Machine World.)

INDIANAPOLIS, IND., July 9.—Indianapolis talking machine dealers assert they are surprised at the manner in which the talking machine business is holding up during the hot weather. None of them

is complaining of business conditions. All are predicting that they will have more trade this fall than ever before.

A. W. Moos, manager of the local store of the Columbia Graphophone Co., has a salesman in H. M. Wright who believes in going to the river for business. Mr. Wright has created a great deal of favorable comment, and, what is more important, has been making a large number of sales by equipping a canoe with a Columbia Grafonola. The canoe is painted red. On the end of the canoe, in silver leafing, is the name "Columbia Grafonola." The craft flies two flags—the American flag and a Columbia pennant. Concerts are given by Mr. Wright every Saturday afternoon and evening. As a result nearly every canoe on the river at Riverside Park is equipped with a talking machine.

Mr. Wright also has designed an attractive mid-summer window. A real Indian wigwam, surrounded by real grass—which Mr. Wright sprinkles each day, and several rabbits make up the window display. Back of the wigwam is an old-fashioned rail fence. On a stump is a Columbia talking machine. Hundreds of passers-by pause at the window every day.

"Business is holding up good," said Mr. Roos in discussing business conditions. "The prospects are that it will continue to be good all summer."

George W. Lyle, general manager of the Columbia Graphophone Co., visited the Indianapolis branch recently.

Alexander M. Stewart, and his son, George Stewart, both of the Stewart Talking Machine Co., have left Indiana for an extended trip through the East. They expect to attend the convention at Atlantic City. They will visit a number of the Eastern cities before returning.

The installation of Victor talking machine departments by the Pearson Piano Co. and the People's Outfitting Co. is announced by the Stewart Talking Machine Co., through whom these companies will get their Victor goods.

The Pearson Piano Co. is planning extensive improvements, and when the company's building has been remodeled the talking machine department will have adequate quarters on the first floor. The People's Outfitting Co. also will make room for a special talking machine department. Both will handle the entire Victor line.

"Business conditions are fine," said W. S. Barringer, manager of the Stewart Talking Machine Co. "We placed our expectations away up and they are now being fulfilled ahead of what we expected."

To add to the efficiency of the Stewart Talking Machine Co. a motor truck for rapid service has been bought by the company. The company will use this truck in addition to a large horse truck.

The Kipp-Link Phonograph Co., which handles the Edison line of talking machines, reports good business conditions for the time of the year. Walter E. Kipp left Indianapolis recently on a visit to the Edison factory.

Some people have so little confidence in themselves that they really don't think they could plan a house better than the architect.

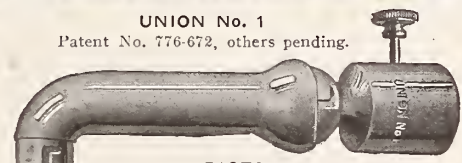

UNION No. 1
Patent No. 776-672, others pending.

PRICES:
Gold plated, Nickel or oxidized .. \$2.50.

4 Easy Sellers—



UNION MODIFIER
Pat. Pend.

PRICE.
Gold plated, nickel or oxidized... \$1.00

THE upper illustration shows UNION No. 1, for playing Columbia and Victor records on Edison Machines. UNION No. 1 contains the UNION Modifier feature. The second illustration shows the UNION Modifier, a quick-selling device, giving Edison, Victor and Columbia owners absolute control over the volume of sound.

UNION TALKING MACHINE SPECIALTIES

AT the right is the new UNION Sound Box, just out, taking Fibre or any make of needle. It is the latest improvement in sound reproduction, and fits all Disc Machines.

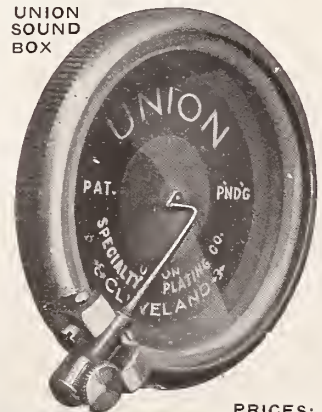

UNION SOUND BOX

The UNION Needle Box shown below fills another long-felt want.

Write to-day for descriptive folders and prices on these four easy-selling specialties.

All persons selling goods infringing our patents are liable to suit for such infringement.

PRICES:
\$4.00.
Gold plated, Nickel, or oxidized,

The Union Specialty and Plating Co.

409 Prospect Ave., N. W. Cleveland, Ohio

LIST PRICES SHOWN HERE

UNION NEEDLE BOX for Edison Machine.

USUAL DISCOUNT TO DEALERS



PRICE:
Finished in Mahogany, Circassian Walnut or Fumed Oak, any finish, 50c.



C. J. HEPPE & SON

VICTOR Distributors

1117-1119 Chestnut Street
PHILADELPHIA, PA.

PHONOGRAPHISCHE ZEITSCHRIFT
BERLIN C. 19, GERMANY

The oldest and most up-to-date trade paper covering the talking machine line published in the German Language.

PUBLISHED WEEKLY. FOUNDED 1900

Circulates all over the world.

SPECIAL EXPORT NUMBERS appear in four different languages at regular intervals.

Subscriptions for this talking machine publication 10 Marks yearly. Sample copies sent free.

PROGRESSIVE JOBBERS ADVERTISE IN THE TALKING MACHINE WORLD. CONSULT THEIR ANNOUNCEMENTS.



The **VELVATONE** talking machine needles can be used on all disc records. Perfect music with the **VELVATONE**—no scratching. Jobbers and dealers who have seen and heard them are enthusiastic over their merits. Get in your order now; be on the right side of the needle argument. It will help you to sell talking machines by making them more popular.

One needle will play a number of records by simply turning the needle **ONE-QUARTER** way round after playing each record.



VELVATONE NEEDLES are easy and convenient to use, and you add a great deal to the enjoyment you now derive from your instrument.



The tone is soft and sweet, and just the proper volume for the home. It is possible that in the first trial you may not obtain the best results, as it is necessary to play the records over a few times with **VELVATONE NEEDLES**, as they will lubricate and polish the grooves of the record. The production will then be clear and smooth, and the **RECORDS** will last indefinitely.

One Velvaton Needle Will Play A Surprising Number of Records

The Chemical process with which **VELVATONE WOOD NEEDLES** are treated contains an oily substance, which acts as a Lubricant, and thus polishes and smooths the grooves of the record to a great extent each time the record is played.



Write for Jobbers' discounts.

Instructions for Using Velvaton Wood Needles—Self Sharpening

Place the needle in the sound box in the same manner as an ordinary steel needle, then, in order to avoid injuring the point of the needle, place it carefully into the groove of the revolving record; let the needle remain in the same position in the sound box as long as it will reproduce perfectly. When it is necessary to change the needle do not throw it away, but turn it one-quarter way round and it will reproduce as clearly as at first. This can be repeated a number of times before the needle is worn out.

The number of records that can be played with a single **VELVATONE NEEDLE** depends upon the condition of the record.

Before perfect results are obtained with some records it may be necessary to play them over several times with a **VELVATONE NEEDLE**.

Jobbers who heard the **VELVATONE** at the Atlantic City Convention were surprised at the wonderful effects produced, and they placed goodly orders for them.

Do likewise—do it now, and quicken your business pulse.



50c. Per Package of 100

Liberal discounts to Jobbers. Full information given upon application

MANUFACTURED ONLY BY THE

VELVATONE WOOD NEEDLE CO.

KANSAS CITY, MO., U. S. A.

THE PATHÉSCOPE WITH WANAMAKER

The Great New York Department Store to Establish Pathéscope Salon to Demonstrate This Amazingly Successful Machine—Pathéscope Exchange of Philadelphia Organized.

It was announced this week at the offices of the Pathéscope, 27 West Forty-second street, New York, that arrangements had been completed with John Wanamaker, New York, whereby this prominent department store would establish a Pathéscope

EDUCATORS KEENLY INTERESTED

In the Talking Machine at Their Annual Convention in St. Paul—New Building, Perhaps, for Lawrence H. Lucker in St. Paul for His Edison Interests—News of Month.

(Special to The Talking Machine World.)

MINNEAPOLIS AND ST. PAUL, MINN., July 8.—Twelve thousand teachers assembled in St. Paul for the fifty-third annual convention of the National Education Association have put the talking machine dealers of the twin cities on their mettle to engage the hungry-eyed, information-seeking pedagogues. The Victor Co. went right into the camp of the teachers with an educational exhibit in the National Guard Armory, where all the teachers registered and where the book publishers and school-supply dealers had their exhibits.

Educators realize the tremendous benefits obtained by the intelligent use of talking machines, and the time will come when every school, in addition to its piano and stereopticon, also will have a high-class phonograph, and the present convention is likely to give a greater impetus to the movement than its predecessors. While the Victor is the only house to get right in to the inner camp, the other houses, through local dealers, are making strong appeals to the teachers through window displays and newspaper advertising.

The Columbia is making a big card of its Grafonola Mobile, which can be trundled from one room to another on its rubber-tired wheels in a moment and without any disturbance. That the device will appeal to principals of large schools is quite natural.

P. P. Claxton, the United States Commissioner of Education, while declining to commit the Government wholly to the use of mechanical devices as aids in teaching and entertaining, said that his bureau workers had made considerable study of phonographs and stereopticons, and while there had as yet been no official report as to their investigation it is well known, he said, that both can be made useful under intelligent administration.

F. A. Westerfeld, superintendent of Dictaphone

agents of the Columbia Co., was in the Twin Cities last week. He stated that the dictaphone was growing in popularity among lawyers and others having large correspondence, and nowhere more rapidly than in the Middle West. Every up-to-date office, even a small one, in time will have an arrangement as part of the necessary furnishings of the office. T. A. Lowrey, traveling auditor of the company, has also been through the Northwest, and it is believed that he found the branch houses doing well.

It is reported in St. Paul that Laurence H. Lucker has obtained the triangular building at Sixth and St. Peter streets, St. Paul, for his proposed Edison shop. The location is in the heart of what is expected to be the new department store district, while the building itself hardly could be improved upon for display purposes, as it has a conspicuous position and ample street frontage. No public announcements have appeared, but there is no question but that Mr. Lucker will put through his plans.

General trade has resolved itself to midsummer conditions. The record trade keeps up among the lake resorters, but the sale of machines is not especially brisk. Still it is as good as last year, and with many dealers a whole lot better.

A CLEVER FILING CABINET.

The Ogden Invention Captures Good Orders from the Trade.

J. B. Ogden, Lynchburg, Va., had one of his new patented record filing cabinets at the Chalfonte, which was greatly admired by visiting jobber at the Atlantic City convention. As a result of the interest which it created, Mr. Ogden took back a substantial number of orders with him.

The Ogden record cabinet enables the dealer to place his hands on any record in stock most quickly. It is equipped with a spring in each compartment that holds all records in an upright position regardless of quantity of records filed and keeps them from warping. It has a simple adjustable signal system which makes quick filing possible and enables the salesman to locate a record immediately. It requires but small space and has a large record capacity. These cabinets are made on the sectional unit system. The record capacity of these cabinets is unusually large and dealers would do well to write to Mr. Ogden for full particulars. He has a special proposition for jobbers.

The fellow who is always forgetting himself has no right to kick when he is forgotten.

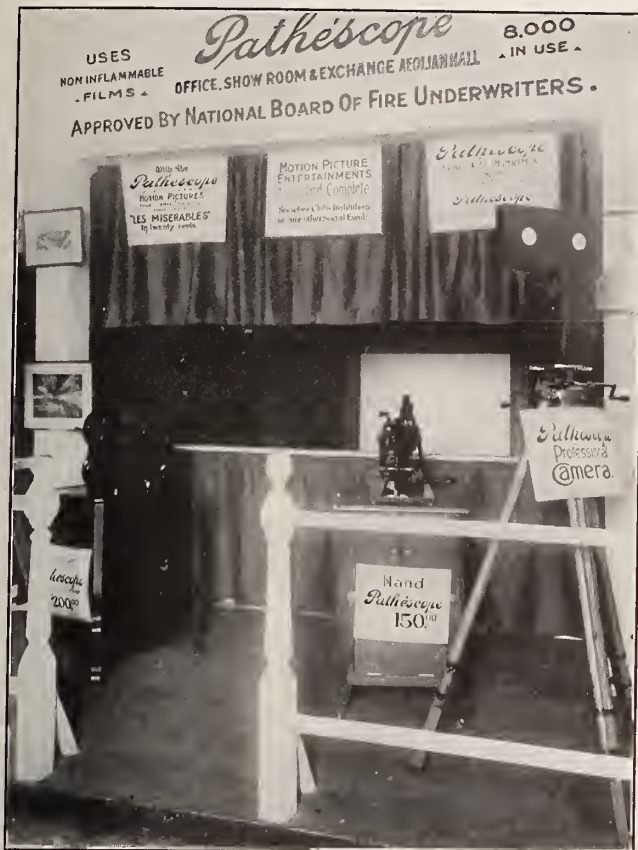

Pathéscope Booth at the Moving Picture Exposition.

salon to demonstrate this successful machine. Loujs J. Gerson, manager of the Wanamaker talking machine departments has carefully investigated the merits of the Pathéscope and is enthusiastic over its future in this country. Mr. Gerson is planning to visit the factory of Pathé Freres, Paris, this summer on his trip abroad.

When seen by a representative of The World, an official of the Pathéscope remarked as follows regarding the firm's progress: "The Pathéscope Exchange of Philadelphia, organized solely to market the Pathéscope in southeastern Pennsylvania and southern New Jersey, has just received its first order of over fifty instruments and sufficient films to conduct a film exchange for their owners. One of their initial transactions was a sale of ten instruments and 16,000 feet of film to a prominent Philadelphia industrial concern.

"One of our recent sales from this office was a motor-driven instrument for the Indian school at Sitka, Alaska. The purchase was made by the Presbyterian Mission, which supports the institution and which has also arranged for monthly service of new films to be supplied regularly from the New York Pathéscope Exchange.

"Our booth at the recent Exposition of the Moving Picture Art at Grand Central Palace, New York, was a decided success. This was partly on account of the smooth operation of our instruments and very largely because, after the first few days, every other motion picture machine on the first floor was stopped by the insurance authorities. On account of its approval by the National Board of Fire Underwriters the Pathéscope was allowed to continue its exhibition without interruption."

It may be a lofty ambition to hitch your wagon to a star, but it is safer to drop your anchor in the mud.

TALKING MACHINE JOBBERS WHO ADVERTISE IN THE WORLD ARE LIVE ONES, TRY THEM!

Service That's Profitable

The VICTOR Machines and Records That You WANT WHEN You Want Them.

Stocks That Meet the Demands of the Dealers Without Disappointment.

Shipping Facilities That Insure Promptness

ACTIONS—NOT PROMISES

That's BLOUT SERVICE

EMANUEL BLOUT

Victor Distributor



2795-2799 BROADWAY (At 108th Street,) NEW YORK

TRADE IN NEW YORK RUNNING AHEAD OF LAST SUMMER.

Jobbers and Dealers Now Placing Their Orders for Expected Fall Trade—No Evidences of the Slightest Business Depression in the Reports of Local Members of the Industry—Sales to Yacht Owners—Noteworthy Speed Record of Well-Known Sales Manager.

The most important topic of discussion the past month among talking machine dealers has been the marked contrast of their business to general mercantile affairs. It is indeed gratifying to visit the various dealers and find that, with practically no exceptions, their business during the month just closed showed a substantial increase over the corresponding period of last year.

To the business man in other mercantile lines this optimism is a great surprise, as general conditions the past month have been very poor and unsettled. The Claffin failure was a bomb-shell in all lines of business throughout the country, and particularly affected New York industrial conditions. Notwithstanding this unrest, however, talking machine distributors and dealers in this territory are emphatic in declaring that their business the past three months has been entirely satisfactory, and that their trade as a whole gives every indication of breaking all previous records by the end of the year.

The local talking machine trade has been an important factor in newspaper advertising the past few weeks. The advent of vacation time, with the consequent demand for dance records and small machines, impressed the dealers with the fact that their advertising in the newspapers would be both timely and effective, and accordingly, good-sized advertisements featuring machines, records and service were inserted at frequent intervals and produced excellent results.

The record problem has steadily improved, and at the present time there is scarcely a ripple of complaint among the distributors or dealers regarding record shortage. The factories are to be congratulated on this excellent situation, as the record demand has been tremendous and beyond all expectation. The increased facilities provided by the manufacturers and the efficiency of their sales organizations have been very important factors in handling this phenomenal record trade.

Business Better Than Normal.

"Our June business was much better than normal," said J. Newcomb Blackman, president of the Blackman Talking Machine Co., 97 Chambers street, New York, Victor and Edison cylinder jobber, "because stocks have been so low that factory shipments are coming through much better than heretofore. This, of course, produces considerable business for the jobbers and dealers who are stocking up at the present time. I believe that the dealers also realize that it is a good, safe plan for them, and to their advantage, to put in machine and record stock now, and carry a larger stock than usual for this year's fall trade.

"Summer business so far has been somewhat better than ordinarily, due in a considerable measure to the continuance of the dance craze. Talking machines are being taken away to summer resorts by their owners for dancing purposes, which also stimulates the demand for the regular catalog records. On the whole, the talking machine business seems to be in remarkable contrast with general business, which is dull and psychologically poor, consequently the talking machine business must be in turn psychologically better than other lines of business, all of which would tend to the belief that psychology is a friend of the talking machine business."

I. DAVEGA, Jr.

125 WEST 125th STREET, NEW YORK

Victor Distributor

PROMPT AND ACCURATE SERVICE

DEALERS: Write for our Victor Pennant. Sent with our compliments.

Reports Gain of 50 Per Cent.

"We showed a gain of over 50 per cent. in our last month's business, as compared with June, 1913," remarked R. F. Bolton, manager of the Columbia Graphophone Co.'s wholesale headquarters, 89 Chambers street, New York. "This gain is doubly pleasing when the general business depression is taken into mind. Collections have been very satisfactory, everything considered, and the outlook is decidedly encouraging. The most important phase of our business in June was the steady demand for the higher priced machines as compared with last June, when the cheaper machines were more in demand."

Demonstrations Attract Trade.

"Our daily demonstrations have proven very successful," said H. N. Purdy, manager of the Edison disc department of Hardman, Peck & Co., 433 Fifth avenue, the prominent piano house, "and we believe they have contributed materially to the excellent June business which we closed in both Edison disc machines and records. As a matter of fact, our sales totals last month exceeded our expectations, and for a summer month were really fine. The Edison disc records are meeting with a ready sale and winning the admiration of all our clients."

A Remarkable Achievement.

Apropos of the recent disastrous fire which almost cleaned out the New York Talking Machine Co., Victor distributor, as noted in detail in another section of this paper, some idea of the tremendous labor involved in replacing the company's stock may be gathered from the following incident: V. W. Moody, sales manager of the company, as soon as the temporary quarters at 77 Reade street had been rented the day after the fire, started, with the help of several men from the Victor factory, to reorder the company's record stock, which had been practically destroyed in its entirety, and to replace the 1,500 machines, which had also been ruined by fire and water. The reordering of the machines presented a comparatively easy problem, as a definite order of the machine number and the style of finish was sufficient. The Victor records could not be ordered in that way, however, as every one of the 5,000 records in the Victor catalog required individual consideration.

It was on this day and night job that Mr. Moody was busily engaged on Thursday morning in company with the factory men when he received a long-distance telephone call from Philadelphia requesting his presence there that afternoon to give testimony in a certain case before the court. At 11:35 Mr. Moody and his three co-workers left the company's headquarters, and at 12 o'clock were on their way to Philadelphia. A table was provided for their use in the dining car, and they continued working until the train reached the "Quaker City" at 1.50. In ten more minutes Mr. Moody was on the witness stand, and, after finishing his testimony, crossed the Delaware River at the other end of Philadelphia and rejoined the factory men at Camden, N. J., at 4.10, which, we may remark, is some traveling.

Columbia Trade Active in New York.

H. A. Yerkes, wholesale manager of the Columbia Co., in a chat with The World, remarked on the excellent reports which are being sent him by all the new dealers who have recently opened Columbia departments in local territory. The aggressive and high-class methods which these dealers have used to secure machine and record business have produced excellent results, as evidenced in the letters Mr. Yerkes is receiving. The enlarged Columbia department at the F. G. Smith store, 335 Fifth avenue, is achieving noteworthy success under the management of Hayward Cleveland, one of the veterans and best-known men in the trade. The Columbia departments in the Kranich & Bach store, Cowperthwait stores and Christman Sons' piano house are all gaining new patrons with pleasing regularity.

Sales to Yacht Owners.

A. N. Struck, manager of the Edison department of the Tower Manufacturing & Novelty Co., 326 Broadway, New York, has been making energetic efforts to develop his trade in specialized fields. Discussing this phase of the Edison business, Mr. Struck remarked as follows: "During the past few weeks we have sold four \$250 Edison disc machines to owners of private yachts who are planning to leave on extended summer cruises. These purchasers, who include prominent business men and financiers, are enthusiastic regarding the tonal qualities of the Edison disc machines and records, and I expect to close several other machine sales to yacht owners within the next few days. The \$250 machine is the most popular seller with all our trade, who consider it the ideal machine from all standpoints."

MICA PRODUCTION LARGE.

North Carolina Yields More Than Half of Country's Output.

(Special to The Talking Machine World.)

WASHINGTON, D. C., July 3.—Mica, which is used to such good purpose in the talking machine field, is found in crystals ranging from small ones to those several feet across. Crystals two feet in diameter are not uncommon. The value of the mica produced in the United States in 1913 was \$436,060, North Carolina contributing \$267,913. The total value of the output in 1913 was \$104,164 greater than in 1912 and was the largest ever reported. The production of sheet mica as reported to the United States Geological Survey amounted to 1,700,677 pounds, valued at \$353,517, compared with 845,483 pounds, valued at \$282,823, in 1912. The production of scrap mica in 1913 amounted to 5,322 tons, valued at \$82,543, compared with 3,226 tons, valued at \$49,073, in 1912.

The survey has just issued its annual report on the production of mica, by Douglas B. Sterrett, but in addition to the statistics of production, markets, etc., this report contains an interesting statement of the mode of occurrence of mica and the kinds of rocks in which it is found, methods of prospecting and mining, and treatment of the product for market, as well as the economic uses of the various kinds of mica.

INCORPORATED IN DELAWARE.

(Special to The Talking Machine World.)

DOVER, DEL., July 6.—The Cortella Talking Picture Machine Co. this week filed a certificate of incorporation with the Secretary of State to engage in the manufacture of talking machines. The capital is given as \$300,000, and the incorporators are A. Antonelli, W. T. Jones and H. L. Touray, Philadelphia, Pa.

VICTOR FOR CHURCH USE.

The Talking Machine Co., of Philadelphia, Victor representative, recently furnished the large congregation of the Bethany Evangelical Lutheran Church with an excellent concert of hymns and sacred music.

It is just as well, when you bottle your wrath, to throw away the corkscrew.

TALKING MACHINE JOBBERS WHO ADVERTISE IN THE WORLD ARE LIVE ONES. TRY THEM!

NAME PLATES
DECALCOMANIE

Why not apply a transfer nameplate on your talking machine cabinets?

WRITE FOR SAMPLES AND PRICES. SKETCHES FREE



GEO. A. SMITH & CO. INC.
74 CORTLANDT ST., N. Y.

Enlightening The Talking Machine World

Our Service—Victor Service.

If it is a physical possibility to fill
an order complete—we will do it.

You will appreciate our Service—
our ability to help.

We ship from Maine to San Fran-
cisco—no matter where you are
located.

*If you are ever short
of goods—wire us*



New York Talking Machine Co.

81 Chambers Street, New York



The increasing Columbia business you are missing ought to make you nervous.

(Reprinted from last year's Convention number. That increase has multiplied since, and by the same token that nervousness of yours can hardly be improving much.)



(Write for "Music Money," a book "full of meat" for those dealers interested in quick and frequent turnover of capital.)

Columbia Graphophone Company
Woolworth Building, New York

THE CORLEY SERVICE APPRECIATED.

Splendid Enterprise Built Up by Progressive Richmond Jobbers—Conducting a Business Over a Large Territory—Attribute Success to the Service Given to Customers.

(Special to The Talking Machine World.)

RICHMOND, VA., July 8.—Mention of Richmond conjures up visions of an historic past, rich in memories of bygone days when all the South acclaimed it the logical location for its capital. It is not, however, of the glories of the past that we have to

three years, until to-day the annual business will approximate a quarter-million dollars! This department is under the direct supervision of Frank W. Corley as general manager, assisted by Fredk. Kessnich, wholesale manager, and a very capable and efficient force of assistants. Hardly a town or village in the entire South is too remote to receive the benefits of the Corley Co.'s Victor service, and the territory is practically bounded by the Gulf Stream, thousands of dollars' worth of goods being shipped annually to New Orleans and even further points. It is a striking com-

service. Particular attention is paid to the exploitation of the latest and most popular numbers of the foreign records, and a stock sufficient to fill any order at a moment's notice is always carried in the record vaults of the company. Another feature worthy of mention adopted for the benefit of their customers is that wherein suggestions for advertising and advertising literature prepared to meet the individual requirements of the customer are designed gratis by the Corley Co.'s advertising department and furnished freely upon request. The success of the Corley Co. in the jobbing line has been marked and emphatic, and it shows what splendid results may be attained from a business built on efficient service.

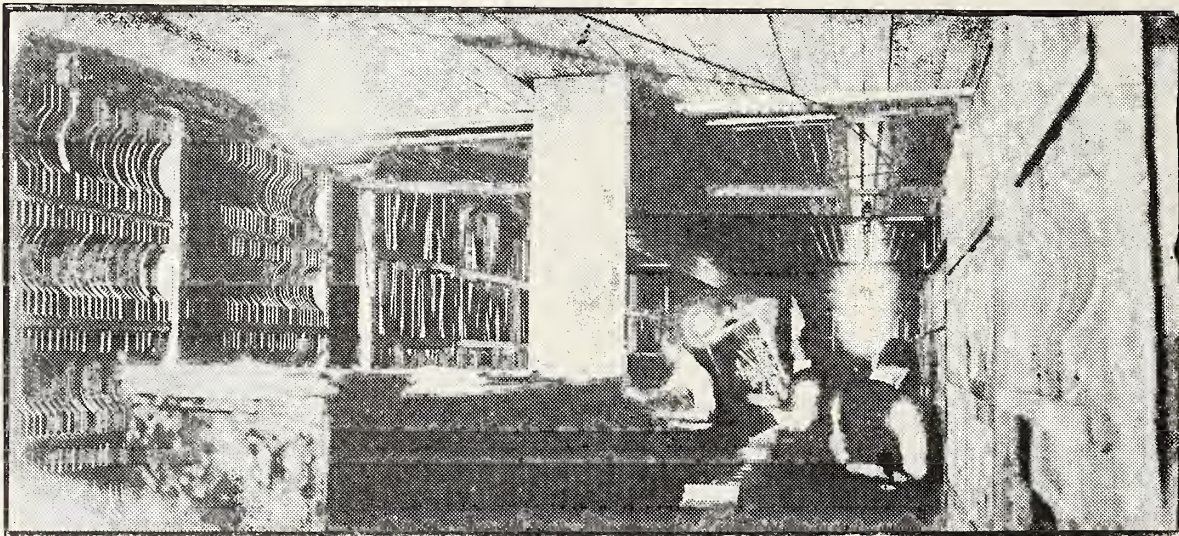

Part of the Vaults of the Corley Co., Richmond, Va.

do with in this article, but of the tremendous commercial activities of the present day in general and the wonderful expansion in the Victor department of the Corley Co. in particular. In the ten years since this department was established the growth has been phenomenally great, exceeding even the wildest dreams of its founders, forging ahead by leaps and bounds from year to year, actually doubling the sales for each of the past

mentary on the business sagacity of the Southern dealers that they have been quick to grasp the manifest advantages of dealing through this progressive house, for the admirable location insures quick deliveries, low freight rates and excellent shipping facilities, and a complete stock of "Everything the Victor Co. makes." makes a combination of irresistible attractiveness, and doubtless explains the success of Corley

piano advertising of a sensational nature for some time past. This law reads:

"Any person, firm, corporation or association who or which in a newspaper, circular or form letter or other publication published in this State wilfully or knowingly makes or disseminates any statement or assertion of fact concerning the quality, the quantity, the value, the method of production or manufacture or the reason for the price of his or their merchandise or the manner or source or the possession of awards, prizes or distinction conferring a gain on such merchandise, or the motive or purpose of a sale, intended to give the appearance of an offer advantageous to the purchaser which is false and fraudulent, shall be guilty of a misdemeanor."

Violations of the new law are punishable by fines of not less than \$25 or more than \$100 for each offense.

"TALKER" MUSIC ON TRAINS.

Talking machines furnish novel amusement on transcontinental trains of the Union Pacific & Northwestern Railroads, where the passengers dance up and down the cleared buffet and dining cars to the merry strains of the latest Victor tango records as played on the Victrola.

TALKING MACHINE JOBBERS WHO ADVERTISE IN THE WORLD ARE LIVE ONES, TRY THEM!

No Talking Machine Is Complete Without An Automatic Stop

STANDARD AUTOMATIC STOP

The Most Perfect Automatic Stop Made

NICKEL FINISH \$2.00

GOLD FINISH \$3.00

Thousands of our Automatic Stops in use over a period of two years, giving satisfaction, silently testify to the excellence of these devices.

Send 25 cents stamps for sample. Write on your business letterhead only. Place regular orders through your jobber.

STANDARD GRAMOPHONE APPLIANCE CO., 173 Lafayette St. NEW YORK

TAKES ON THE COLUMBIA LINE.

The Schoen Music Co., Who Recently Took on This Line Reports Encouraging Business—Schroeder Piano Co. Doing Well in Talking Machines—Henry's Taken Over by A. J. Meyer—Kaufmann Bros.' Big Victrola Business—Other Pittsburgh Happenings.

(Special to The Talking Machine World.)

PITTSBURGH, PA., July 9.—The Schoen Music Co., 119 Federal street, North Side, has taken on the Columbia line and reports a very encouraging business. One of the large show windows has been given over to an effective display of machines and records and is attracting much attention. Mr. Schoen says that the sales of records have been unusually high during the past few weeks. The Schoen Music Co. has heretofore confined its business almost exclusively to pianos.

The new talking machine department of the Schroeder Piano Co. has far exceeded all expectations by its business for the first month of its existence and the outlook is very promising. The sales of \$200 machines are reported as having been especially good. The Columbia line is being handled exclusively. Miss H. R. Dunn, who is so successfully managing the department, is planning to leave soon on a three weeks' vacation trip, most of which she will spend on the Great Lakes.

H. N. Rudderow, manager of the Kaufmann Bros. Victrola department, states that business has been very good especially during the past two or three weeks. The two outside salesmen are handling some very good trade, and the inside salesforce has been increased by the addition of another saleslady. Mr. Rudderow reports that the new style Victrolas are meeting with a very favorable reception. Since the beginning of the camping and vacation season a large space of the eleventh floor just off of the Victrola and piano department has been given over to a realistic camping scene with the Victrola camp outfit in use. Tents, hammocks, canoes and the indispensable Victrola are shown in the environ-

ment of an ideal camp among the woods and hills. The exhibit is one of the finest and most pretentious of its kind ever shown here.

Henry's, 614 Penn avenue, in the last week of June was taken over by A. J. Meyer who is now almost sole owner, although the company still remains a corporation with several others holding a small amount of the stock. E. A. Grau has retired from the business and is contemplating entering some other line. Mr. Henry, who now resides in California, sold his interests in the firm to Mr. Meyer about three years ago. The name of Henry's is being retained, however, on account of the prestige acquired by the old firm of Powers & Henry, which was one of the pioneer talking machine houses of Pittsburgh. Mr. Meyer is very sanguine over the outlook of the Victrola business and reports that there has recently been a marked increase in both inquiries and sales.

Among Pittsburghers attending the national convention of the Talking Machine Jobbers' Association at Atlantic City, are J. C. Roush, of the Standard Talking Machine Co., and French Nestor, manager of the W. F. Frederick Co.'s stores.

Mr. Harned, of the W. F. Frederick Co.'s Victrola department, reports that for the first six months of 1914 a gain of 90 per cent. has been made over the sales of the same period of last year. Camp outfits are being featured with splendid success.

SOME BALTIMORE BRIEFLETS.

Convention Attracts Some Baltimoreans—Droop Enlarges Store—Business Is of Fair Volume—Vacations Now Under Way at All Stores.

(Special to The Talking Machine World.)

BALTIMORE, MD., July 9.—Most of the Victor jobbers are in Atlantic City this week attending the convention, but despite this fact, reports at the various stores indicate that the summer months are having little effect upon the sales. Business has been keeping up in good shape and many substantial sales have been placed on the books. These include a number of the high-priced machines of the various makes.

W. C. Roberts, of E. F. Droop & Sons Co., and Joseph Fink, of the Fink Talking Machine Co., are among those taking in the Atlantic City convention. Before leaving for the seashore both of them reported that they had a very satisfactory June with regard to sales of machines and records.

The store of E. F. Droop & Sons Co. has been greatly improved and enlarged during the month so that the firm now has twice as much room as it had formerly. The offices have been placed in the rear where the new addition was made and the salesrooms are in the front and have been doubled in capacity.

F. A. Dennison, manager of the local branch of the Columbia Graphophone Co., is away on his vacation for two weeks. Mr. Dennison is spending his time at Rehobeth Beach, Del. Reports at the store show that June was likewise an excellent month for the Columbia trade.

Reports from H. R. Eisenbrandt Sons show that this firm enjoyed the fruits of a good June trade and that indications point to a duplication of the good results during the present month. This firm handles the Victor lines.

The Kunkel Piano Co., which also handles the Victor line, is playing up the talking machine business very elaborately and with good results. The firm has a very neat Victor window display this month.

The Sanders & Stayman Co., Inc., which handles both the Victor and Columbia lines, announces that both ends of the business have been quite prosperous during June.

BURGLARS DESTROY STOCK.

A band of motor-car thieves visited Yonkers and robbed several residences and a number of stores last week. Among the stores visited was that of the Yonkers Talking Machine Co., where little was taken but considerable property wantonly destroyed.

TALKING MACHINE JOBBERS WHO ADVERTISE IN THE WORLD ARE LIVE ONES. TRY THEM!

GOOD SERVICE

Easy to promise—but does your jobber MAKE GOOD during the ELEVENTH HOUR RUSH?

Does he WHOLESAL ONLY, or is he a retailing jobber?

WE GUARANTEE FILLING ORDERS FROM OUR REGULAR DEALERS THIS FALL—COMPLETE ON THE DATES SPECIFIED—but to obtain our service

YOU SHOULD BE ONE OF OUR REGULAR DEALERS if you expect to get this special service.

EVERY ORDER SHIPPED TO YOU
THE DAY IT IS RECEIVED BY US.

STANDARD TALKING MACHINE COMPANY

We are wholesalers only—Victors Exclusively

800-802 PENN AVENUE

PITTSBURGH, PENNA.



We have enough big news for Columbia dealers this Fall to make them think that their best months heretofore were only promises.



(Write for "Music Money," a book "full of meat" for those dealers interested in quick and frequent turnover of capital.)

Columbia Graphophone Company
Woolworth Building, New York

SOME INTERESTING CUSTOMERS I HAVE MET

As Told by Benj. Switky, the Prominent Victor Distributer of New York—The Necessity of Studying Human Nature with a View to Reading the Minds of Customers, Illustrated by Some Actual Experiences—A Great Diversity of Desires to Be Catered To.

If the boss isn't looking, I would like to whisper something into the ear of his salesman, to the effect that he is getting, over and above his salary, a certain compensation or advantage not nominated in the bond. I hope not to be taken too seriously when I point out the fact that a salesman in a talking machine store has a beautiful opportunity to study psychology without going to college and without paying any tuition fee.

Psychology is the study of the mind. It is recognized as a distinct branch of science. It has to do with observation of the workings of the human brain—whether normal or abnormal—marking the deviations, the conscious and subconscious impressions made on the brain, and the subsequent thoughts and actions.

"But what has all this to do with selling records?" you may ask. A great deal. Every salesman depends on his "instinct" in handling his customer. He sizes up the clothes, deportment and features of the prospective buyer. Whether demonstrating the line of machines or playing records, the salesman tries to read the thoughts of his customer. He watches his expression to learn what class of music he prefers. He tries to impress his own thoughts on the mind of his customer, so that he will buy a higher priced machine or decide to take home certain records which the salesman feels sure his customer should buy. All this mental work involves psychology.

The better the salesman the more proficient is his ability to read his customer's mind; and I don't know of any business that yields a better opportunity to study psychology—or human nature, as it is sometimes expressed. But no matter how expert the judgment, it often goes wrong.

An Aristocratic Buyer Misjudged.

I once waited on "a lady of quality." She was recommended by a customer of mine, with whom she made an appointment to meet at my store, to buy a Victor. She arrived in grand style, with carriage and pair, liveried coachman and footman, and all the trappings that accompany a grande dame living on Fifth avenue, right off Central Park, New York City. At that time our best machine was the Victor VI. Without deigning to examine the machine, she wanted to know if that was the best made. Likewise we had to assure her that there was not likely to be a better one marketed in the near future.

Then came the selection of records. By all means she wanted all the fine records that her friend suggested. In addition she must have the expensive Red Seals which she had heard around the homes of her many friends. After that I got the shock of my life when she beckoned to me with her lorgnette that I should step closer. With a most engaging smile she asked me sort of confidentially, "Have you got anything in the way of a real nice, refined coon song?" When she heard "Nigger Loves His Possum" she was delighted.

After that I made up a special collection of coon songs, ragtime music, minstrels, etc., which she kept as her very own. The others were intended for company only.

Real Lovers of Music.

New York is a wonderful city—wonderful because of its extremes. The superlative in everything abounds here. The greatest wealth and the most abject poverty; hundreds of amusement palaces catering to the gay, and hundreds of ill-smelling lodging houses patronized by the miserable; awe-inspiring skyscrapers rubbing elbows with two-story shanties. Likewise, it is nothing unusual to be selling records to a millionaire in one booth and to a collarless mechanic on the other side of the partition. The former may be selecting tangos and trots to help him in his dancing lessons, whereas the other wants the heavenly kind of music, the kind that will help him to forget his troubles for the time being.

One of my most appreciative customers was an Italian tailor. He and his wife would call regularly on Saturday on their way home from the cloak shop where they were both employed, of which there are many in the vicinity of Fifth avenue below Twenty-third street. They always carried with them a thumbworn catalog in which they had marked off the records bought to date, as well as those they intended to own just as quickly as their meager earnings would permit.

After listening to two or three selections they would choose one and assure me that they meant to buy the others also—but not to-day. Every Saturday for nearly two years they would spend two or three dollars—rarely four—for a new record.

I shall never forget the ecstasy with which they listened to the seven-dollar Sextet. I played it for them on several different occasions just to give them a treat. At last they fell. The temptation was too great. The wife's birthday was near at hand, and they decided to buy it on my suggestion that they could pay for it in two or three payments.

It is a well-known fact that Caruso's voice is to be heard floating through more than one open window any summer's evening or Sunday in Mulberry street or Elizabeth street.

The Educational Value of the Talking Machine.

About two years ago a gentleman and a little girl came into the store. It was just before Christmas. They had spent the greater part of the day "rubbing" in the department stores, enjoying the holiday exhibits and decorations for which this class of stores is famous, particularly in the metropolis. It seems that this little girl coaxed her father to enter the store under the pretext that she felt tired, and possibly because the big leather upholstered armchairs looked so inviting.

It just happened that there was a lull in business, so I offered to play for them a record or

two by way of diversion. Turning to the gentleman, I inquired whether there was any particular selection that he would like to hear.

"Me? No, thanks. I wouldn't give one of them things house room!" was the reply.

"Wouldn't you like to hear something nice?" I inquired of the girl, nothing daunted. "We have some nice records for children. There's 'The Tin Gee Gee,' or a laughing song by Harry Lauder, or a funny story by Uncle Josh."

"Oh, no," she answered, "my favorite is the 'Barcarolle,'" and she hummed the air from the "Tales of Hoffman."

"My girl has outgrown all that baby trash," chimed in the father, proudly.

There was my cue, and I followed it up. First, I complimented him on the fine home training that his little girl showed. Then I argued with him that in justice to the child it was his duty to provide her with a Victrola; that, being susceptible to good music, she should be surrounded with every possible musical influence that would aid in educating and refining the child. I pointed out to him the fact that the girl evinced decided talent musically and that he should lose no time in obtaining for her a piano teacher. This suggestion delighted the girl.

But the interesting part of my story is not only that the thought-seed sown in the father's mind took root, but in addition to her music lessons, he surprised her one year later with a Victrola as a Christmas present to aid her in her studies. And, what is more, the father finds pleasure and comfort in listening to the Victrola.

Parental interest and pride in their offspring is the most vulnerable spot in the armor of indifference which the salesman often is called on to combat.

If we but knew how many machines are bought just for the sake of the children we would make it our business to cater still more to the little ones. "Suffer little children to come unto me" is a teaching that is as good and true for us to-day as it was when Christ uttered it. And the conversion of the parents from a state of indifference to the state of music lovers has been the mission of the talking machine. Oliver Goldsmith expresses the thought beautifully in one of his works, when he says, "And those who came to scoff remained to pray."

Customers That Don't Want What They Want.

"I want a funny record for a child," declared a lady one day, as she seated herself prepared to listen. I played six records, each of different

**ANDREWS MUSIC
HOUSE CO.**

98 Main Street
BANGOR, MAINE

VICTOR DISTRIBUTERS

character, but all that I thought would surely please any child. Not even the slightest sign of approval could I get from the lady. I was commencing to size her up as a time-killer. I'll admit that my patience was well-nigh exhausted. However, I thought I would stick to it just a record or two longer.

"What is that record being played over in that other booth?" she inquired.

"That, madam, is Liszt's 'Hungarian Rhapsody,'" I replied.

"Beautiful! I want that by all means."

After I had sold her about \$10 worth, all classic music; I still tried to learn why she could not decide on a record for the baby.

"Well, you see, while I wanted to get a record especially for the baby, I realized that it would be played all day long and that we would be obliged to listen to it—and I just couldn't stand it!"

Helping the Customer to Select Records.

It is surprising to notice how abnormally some people can behave while choosing records. I have known otherwise good-natured customers to, tax the patience of the salesman, have him play a dozen or more of the finest and best selling records, find nothing that appeals to them, and finally, from sheer desperation, select a record just to repay us for our trouble.

It was not because of any cussedness, or meanness of spirit, or economy of purse. They would gladly buy if they could be suited. The fault lies in the fact that they have no musical taste or judgment. Fearful of the criticisms of the folks at home, they feel helpless, vacillating, undecided. It requires the dominating judgment of the salesman to force upon them the good records, assuring them and convincing them that after several hearings the records will surely appeal to them more strongly.

Every salesman can recall from experience making sales of certain selections which were rejected on first hearing one day and bought on second hearing another day. While this fact may occasionally be attributed to the difference in the buyer's mood or disposition on the two different occasions, it is more likely that the second playing pleased because the customer became more familiar with the music by repetition.

It is a well-known fact that familiar music sells more readily. While there are certain compositions that are so striking and so abstrusively good or catchy that they appeal instantly to the average listener, there are, on the other hand, many beautiful compositions, particularly among the classics, which must be heard several times to be appreciated.

Why Certain Records Sell Readily.

Such compositions as the "Anvil Chorus," "Toreador Song," Intermezzo from "Cavalleria Rusticana" and the "Merry Widow Waltz" are ready sellers for one of two reasons: either because the selection is a familiar one, or, as in the case of the "Merry Widow Waltz," because the melody is sing-song, very simple and oft-repeated from start to finish of the record. These selections are grasped by even the weakest of musical brains.

On the other hand, selections such as "The Angelus," from "Sweethearts," "Merry Wives of Windsor Overture," "Song of the Soul," "Le Nil"—all of them beautiful compositions—do not sell so readily because they must first filter or percolate through the average brain. On the first hearing such music does not usually quicken the pulse sufficiently nor stir the hearer into decisive action. It is good salesmanship to play over such selections a second time for the customer.

We must try to reason out and appreciate the workings of the customer's brain, so as to be able to help him to arrive at a decision in the selection of records. The gratitude of the buyer will well repay the salesman. He will feel that nowhere else could he receive such good treatment.

I hope that I have made clear to the reader the benefit, pleasure and self-culture that falls to his lot as the result of intelligent intercourse with the many different specimens of humanity that circulate in every talking machine store wherever located.

We Do Not Retail

THERE is a world of support and profit to the dealer in *this policy of ours.*

We are here to serve *you only*, without exception, and thus our efforts are entirely and continually applied to that purpose.

An adequate stock, complete and modern equipment, and a superior organization make it possible for us to serve you well and that is the result we strive for and attain.

C. Bruno & Son, Inc.

ESTABLISHED 1834

Victor Distributors
Musical Instruments

351-353 Fourth Avenue
(From 25th to 26th Street)

NEW YORK

A PROFITABLE SIDE LINE.

Many Talking Machine Dealers Realize the Possibilities That Exist for the Promotion of a Successful Musical Merchandise Business, but There Are Others Who Overlook This Fact—Importance of Getting in Touch with Buegeleisen & Jacobson and the Advantages Therefrom Interestingly Set Forth.

"I am certain that if talking machine dealers throughout the country fully realized the possibilities that exist for the development of the musical merchandise business there would be very few dealers indeed who would not be carrying sufficient stocks of musical instrument strings and the smaller wares to take care of the demands of their trade," said Samuel Buegeleisen, head of the prominent musical merchandise house of Buegeleisen & Jacobson, 113 University place, New York, and one of the best informed men in the industry.

"There was a time, and not so long ago, that talking machine dealers who contemplated han-



The Durro String Pouch.

dling small goods as a part of their business were confronted with the problem of securing additional floor space, experienced sales people and other incidental requirements which would soon eat up all the profits. The question of room was a particularly troublesome one, and many talking machine dealers, who would otherwise have arranged to handle lines of musical merchandise, were deterred from so doing because of a lack of sufficient floor space and disinclination to increase their rent.

"Realizing this condition, we labored for some time to perfect a series of dealer helps and articles which would occupy a minimum amount of room in the dealer's establishment, practically act as silent salesmen, and contain sufficient merchandise to give the dealer an adequate stock to cater to the needs of his patrons. Our 'Silent Salesmen' glass show cases solved this problem,

as these practical display cases permit the dealer to carry a full line of up-to-date small goods, show them to the best possible advantage, and all in a space five by twelve inches. These glass show cases can be placed on top of each other, and in every way are well worth the attention of the live-wire talking machine dealer.

"We carry quite a number of these 'Silent Salesmen' show cases in stock, and particularly feature those cases displaying the violin bridge assortment, clarinet pad assortment, mandolin pick assortment, violin tail-piece and tail gut assortment, violin peg and mute assortment. The merchandise contained in these glass show cases is of first class quality, and so priced that the dealer may secure an excellent profit from its sale. The glass show cases are furnished free of charge with the various assortments.

"In presenting our No. 6 show case, which is an attractive cabinet designed to display strings for all instruments, we believe that we have perfected an article that the talking machine dealer can use to splendid advantage. The importance of the string business is generally recognized, but the dealer has heretofore found it difficult to secure enough of the right stock and was often at a loss just how to display it. Our string cabinet occupies very little room, measuring actually 12½ inches by 16¼ inches and 4 inches in depth. In this very small space the dealer can display assortments of strings for the violin, mandolin, banjo and guitar. This handsome show case is also furnished free of charge with the strings, and I may say that the strings furnished with this cabinet are fully guaranteed in every detail.

"We are constantly aiming to introduce novelties that will help dealers close sales and increase their profits, one of the most recent of which is our 'Durro' string pouch. This pouch has been on the market a short while, but has already won the approval of our trade throughout the country. It is of practical value to the violinist, and we are including it without charge with the orders for the Durro strings contained in the pouch."

WIRELESS MUSIC 200 MILES.

Strains from a Gramophone Picked Up by a Ship at Sea.

Strains from a gramophone playing "The Merry Widow Waltz" and "God Save the King" were heard lately by wireless in the Nelson Line steamship "Highland Scot" during a voyage from London to Buenos Aires by the third officer. The boat was passing Vigo at the time, and afterward it was found that the ship from which the wireless came was a private yacht 200 miles away.

Mr. Marconi, commenting on this report, said: "They were probably experimenting with a gramophone and a wireless telephone transmitter aboard the private yacht. Tunes are transmitted and caught up in this way. I never heard of its being done over such a long distance, but it is quite possible. Gramophone tunes have been sent by wireless telephony from Marconi House to my house at Fawley, near Southampton."



NYOIL
For polishing varnished woodwork it is extremely satisfactory. No oil is so clean.

Ask your watch repairer whose oil he uses on your watch.

WALZ'S VICTROLA SIGN

In El Paso, Tex., Is Attracting Attention—Is Imposing and Well Arranged.

(Special to The Talking Machine World.)
EL PASO, TEX., July 6.—The W. G. Walz Co., the prominent talking machine establishment of this city, has recently erected a very imposing electric sign devoted to the exploitation of the Victor talk-



Imposing Victrola Electric Sign.

ing machine, a small cut of which appears herewith. As may be judged, the sign is a very large one and very effectively arranged, so that it never fails to attract the attention of the public. The Walz Co. reports a very large business in the talking machine field, and with the excellent crop prospects throughout its territory looks for a very large volume of trade the coming fall and winter.

TALKING MACHINE JOBBERS WHO ADVERTISE IN THE WORLD ARE LIVE ONES. TRY THEM!

All the music—and nothing else.

Our slogan: "Please thy neighbor as well as thyself."

Modify and clarify the music. Play old favorite records now discarded because of the scratches.

Agents Wanted.

You must act quickly to secure territory.

PATENTED MAY, 1914. By A. S. B. LITTLE

THE "LITTLE ONE-DER" ATTACHMENT



THE LITTLE ONE-DER CO., Calvin Ave., Nashville, Tennessee

It fits Victor and Columbia Machines and Records.

Place it in the needle-holder and insert needle in the orifice.

Uses standard needles.

Eliminates the scratch and scrape noises in new or old records.

Retails for \$1.00.

Low prices to dealers in lots of fifty.

Get literature and send for sample.

The Unusual Attractiveness of the Victor Plant.

A Tour of the Factories is an Inspiration and a Revelation—A Million and a Half of Money to be Expended in New Productive Facilities—An Industrial Organization in Which Everything Moves With Mathematical Precision—The Work Conducted Under the Most Favorable Conditions.

Visualize upon the little insert illustration shown in the upper right hand corner of the scene depicted below, then halt a moment to survey the wonderful array of factories pictured underneath it. What a view of industrial expansion is shown here! Can there be a better illustration of the marvelous—almost miraculous—development of a business within a brief period of time?

This illustrates in concrete form what the forces behind the Victor enterprise have accomplished

A tour of the Victor plant is an education in itself, and no one can inspect the productive departments of this enterprise without departing with a greater admiration than ever before for the industry itself. One must feel a new pride in the talking machine industry, a new inspiration to carry on the work in relation thereto, and yet the growth of this immense business is reflected in the corresponding growth of Victor dealers. Every time new additions are made it means, nec-

statement will give some idea of the system and exactness necessary in every department in order to successfully utilize such a vast working force, avoiding congestion or delay at any point, every department moving on in perfect harmony, so that there is no deviating from the fixed rules throughout the entire factory organization. This system is in evidence straight down to the shipping department, where the crating of Victrolas shows that every departmental system has been



The Immense Plant of the Victor Talking Machine Co., Camden, N. J.

since 1898, and surely, as one surveys this magnificent array of buildings devoted to the creation of Victor products, one would think that a halt—a breathing space—might be indulged in by the creative departments; but no, there is no halting—that word is not in the Victor vocabulary.

In the illustration, where the numbers "18" and "19" appear, will shortly be erected a magnificent administration building which will contain the general offices of the company. This will cost \$50,000. Then, if we trace down the picture toward the river, we locate ground where shortly space will be devoted to the enormously increasing present factory facilities of the Victor Co. In brief, there will be during the next twelve months a million and a half of money spent on factory betterments by this corporation. That fact alone emphasizes the resources of the Victor Co. and its desire to fill the orders which are constantly pouring in upon it for machines and records.

Thus, by a study of the factory panorama, it will be seen how the little acorn planted in 1898 has grown into a mighty industrial oak whose branches are constantly extending their sheltering influence to all parts of the world.

One should not pass by this illustration without careful study, and talking machine representatives in every part of the world should feel a thrill of pride in having an organization with such immense resources behind them.

A study of this picture should be supplemented by a visit to the Victor plant, because all the descriptive matter which might be written fails to give an adequate impression of the tremendous Victor manufacturing resources. It is easy to say on paper, "Acres and acres of floor space devoted to the production of machines and records," but yet that statement slips off the tongue easily without perhaps conveying the proper impression to the mind of the reader.

essarily, to jobbers and dealers, a vaster outlet for Victor products. In other words, greater prosperity for Victor representatives everywhere.

At Camden one can go through Victor buildings where, for hundreds of feet, nothing can be seen but an endless row of men and machinery busily engaged in carrying on detailed work, and on and on through acres of floor space until the brain is appalled at the magnitude of the enterprise.

Every part is moving in such complete harmony with every other part. To tell the story of the operations would require a volume in itself, but there is in every department the same rhythmic movement, the same exactness and thoroughness which wins the admiration of all beholders.

In each department there are special features which are of great interest, and this becomes intensified as the visitor moves on through the several buildings.

One thing that must particularly impress sight-seers in the Victor factories is the splendid sanitary conditions under which the operatives work. In all of the buildings every point which makes for health advance has been considered, so that there is splendid light and ventilation afforded on each floor. Even in the motor working rooms, where under ordinary conditions there would be an accumulation of metal dust, all of this is taken care of by exhaust pipes which render the air pure and clear.

There is probably not a factory in the world where there has been greater care and attention given to the healthful condition of operatives than in the Victor plant. Perfect light and air are factors in keeping up the highest grade of efficiency on the part of the workmen, and when we consider what an army of men enters the Victor factories each day the importance of this environment will be made clear. Over six thousand operatives constitute the Victor army. That

figured out in the most exacting and painstaking manner.

It would be difficult to tell which factory department possesses the greatest interest for the sight-seer. All in turn possess charm and attractive power which is maintained right through to the finish, where the speed and exactness with which the Victrolas are crated and shipped is a revelation to the uninformed.

SEE HOW THE JOBBERS IN THE WORLD CAN SUPPLY YOUR WANTS.

**Victor
Distributors
Edison Cylinder
Jobbers**

Penn Phonograph Co.

17 SOUTH NINTH STREET
Opposite Post Office PHILA., PA.

NEW RECORD DISPLAY STAND

Put Out by the Local Headquarters of Columbia Graphophone Co. Has Made Quite a Hit with Dealers Who Find It a Most Effective Means of Attracting the Attitude of the Public.

"The success of our new record display stand has exceeded all our expectations," said R. F. Bolton, manager of the wholesale headquarters of the Columbia Graphophone Co., 89 Chambers street, New York. "Although we have not given this stand any publicity aside from our salesmen carrying a sample stand with them on their trips, we have received orders for the stand and the



record slips from all parts of our territory, and even from the adjoining States.

"Our dealers appreciate the fact that an attractive display of the month's new records cannot fail to be commented on very favorably by their prospects, customers and passers-by, and the high-grade character of this display has served to make it a prime favorite. We furnish the stand and the record slips to our trade at a cost of 75 cents a month for a period of six months."

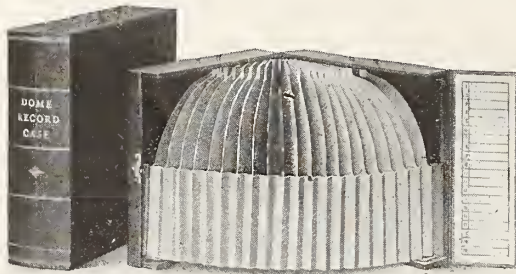

Dome Record Case

It holds 20 records, which are readily accessible for instant use. A convenient index shows just where each record is. Notice how the case swings open so the repertoire is displayed. It is constructed along different lines, being reinforced at the bottom with a nickel-plated metal support to keep the records in position.

Keeps Valuable Records Under Lock and Key

Try a sample of each, 10" and 12". If not satisfactory you may return them. Include record numbers you need and perhaps you want a particular model Victrola, which you are unable to get elsewhere. We have every model in stock.

Our shipping facilities are the best; thirteen lines of Railroad and five Express companies; also boat lines on the Great Lakes.

By sending us your order you have two of the largest jobbing stocks at your service.

W. D. ANDREWS

Buffalo, N. Y.

TRIUMPH FOR MARRIED MEN.

Great Combat on the Ball Field Between the Single and the Married Men of the New York Talking Machine Co. Results in Victory for the Latter—Game Aroused a Great Deal of Enthusiasm—Some "Star" Work.

An event of unusual interest was staged on Saturday, June 13, when the married men of the New York Talking Machine Co., 81 Chambers street, New York, Victor distributor, engaged in combat on the ball field with the single men of that company. This game is an annual affair, and invariably proves exciting and even thrilling. This year's game was no exception, for after a hard-fought match, replete with sensational catches and fierce batting rallies, the married men emerged victors with the long end of a 11 to 9 score. This victory upset all traditions and precedents, as the bachelor contingent had confidently expected to "walk away" with the game.

The game was played on diamond No. 3 at Van Cortlandt Park, New York, and the weather conditions were ideal, the temperature being just right to make for the comfort and convenience of the players and the spectators. After preliminary practice had occupied the attention of the "fans" for a short while the following line-ups for the two teams were announced: Married men—Davin, left field; Hambridge, right field; Bieling, second base; Moffatt, third base; Moody, center field; Owens J. Doty, first base; Beers, shortstop; Arthur D. Geissler, pitcher; Heimberger, catcher. Single men—Radke, left field; Graham, right field; Turner, second base; Dansinger, third base; Pyatt, center field; Howells, first base; Miller, shortstop; M. Owens, pitcher; Slattery, catcher. Messrs. Kingston and Revis, representing the benedicts and the bachelors, respectively, were announced as the official umpires for the pastime.

The first inning proved an easy one for both teams, Davin of the married men missing a sure hit through a remarkable catch by Turner. A. D. Geissler, pitching for the benedicts, was invincible in this inning, only three men facing him. The second inning, however, was the occasion of some old fashioned slugging on the part of the married men, seven runs crossing the rubber through clean hitting, coupled with a brace of errors; Davin of the married contingent sending in three runs and scoring himself on a hit which should have been an "out," or at best a single, but was fumbled and badly handled by the bachelors' infield.

In nowise dismayed or daunted by this terrific batting spree, the single men turned their entire attention to the game for the next few innings,

and Pitcher Owens refused to let the married men add to their already imposing total. In the meanwhile the "singles" were batting the ball at a merry clip, and when the smoke subsided at the end of the seventh inning the bachelors had the game in hand by a score of 8 to 7, and to all appearances had plenty of reserve force for the next two innings. Home runs by Miller and Howells featured the heavy artillery batting during these "joy fests" on the part of the single men.

In the eighth inning a triple play, that rarity of baseball, was pulled off by the bachelors when the married men had three on bases and seemed on the sure road to victory. The ninth inning opened with the score still 8 to 7 in favor of the single men, and with strong resolution evidenced in their every motion, the married men prepared to place the game where they believed it justly belonged—in their victory column. Sales Manager Moody, the first man up, to the great surprise of himself, his friends and the fans, tripled to deep center. Doty followed with a double, scoring Mr.



My, but the Benedicts Felt Joyful.

Moody, and Beers worked Pitcher Owens for a pass. With the score tied and two on the bags, Pitcher A. D. Geissler faced the opposing pitcher with confidence and grim determination. With the grand stand imploring him to send in the winning runs, Mr. Geissler's college baseball training came to the fore, and a hot liner which no one could touch sent two runs across the plate and enabled Connolly, who was running for Mr. Geissler, to also score, giving the married men a total score of 11. In their half of the ninth the single men tried hard to pull the game out of the fire, but fell just a little short, being only able to score a single run before Radke ended the game by striking out.

The grand stand was filled with the wives, friends and children of the company's employes, among those rooting for the married men being the following: Mrs. A. D. Geissler, Mrs. V. M. Moody, Mrs. John Owens, Mrs. Doty and Mrs. Donovan. All the young lady employes of the company, it is needless to say, were enthusiastic rooters for the single men's nine.

GRANT DRAWBACK ALLOWANCE.

The Treasury Department has granted to the Sonora Phonograph Corporation, of New York, a drawback allowance on phonographs manufactured with the use of imported motors, sound-boxes, tone-arms and automatic stops.

George Brown, Jr., has opened a talking machine store in Hissboro, Ill. He will handle Columbia and Edison machines and records, and use automobiles for covering a wide territory.

Many a man is so small that even his own opinion of himself doesn't fit him.

TALKING MACHINE JOBBERS WHO ADVERTISE IN THE WORLD ARE LIVE ONES. TRY THEM!

FROM OUR EUROPEAN HEADQUARTERS

2 GRESHAM BUILDING, BASINGHALL STREET E. C., LONDON, W. LIONEL STURDY, MANAGER.

Comparatively Good Trade Showing Maintained During Dull Months—Plenty of Time for Vacations and Plans for New Conquests—Chappell & Co. Copyright Action Creates Comment—Ramifications of New Copyright Law Being Disclosed—Utility Trading Co. Representing Favorite Record Co.—Recently Formed Understanding Among German Talking Machine Manufacturers Not Working Along Satisfactory Lines—Hoffay's New Gramophone—Cupid Buys at Columbia Headquarters—Conditions with Lindstrom.

(Special to The Talking Machine Wor.)

LONDON, E. C., ENGLAND, July 5.—Considering that business generally is not overbright, the leading gramophone companies are to be congratulated upon the comparatively good trade showing maintained during the past month. It is, of course, an ever-green subject of discussion why the average dealer will persist in regarding summer trade prospects with indifference when proof in many directions is available to show that with persistent effort fairly good business is possible, and were it not for this apathy, at least the belief exists in manufacturing quarters, there would be eliminated the chief cause for much of the unilluminating explanations anent so-called seasons. Be that as it may, at the moment we can but deplore this absence of intelligent interest and neglect of the hundred and one channels of prospective sales which the summer months furnish the enterprising minority of retailers who laugh at rising temperatures and pursue their work unswervingly. To pass on, I find during a round of the trade the majority of firms are by no means busy. It is not, therefore, surprising that gramophone men should be studying timetables and making preparations for a vacation. Several are already on holiday, enjoying themselves at the seaside, on the breezy moors or where fancy leads.

The copyright action between Chappell & Co., Ltd., and the Columbia Graphophone Co. continues to excite great interest in gramophone circles, chiefly on account of the defendant's intention to appeal against the lower court's decision. In this Justice Neville ruled that to orchestrate a copyright song in place of its original pianoforte accompaniment for purposes of recording was an infringement of the copyright in that it was not a "reasonable adaptation" within the meaning of the act. The result of the appeal will therefore be awaited with keen interest, since the point at issue is of vital importance to all makers of records.

For purposes of accompaniment the chosen instrument or instruments must be those calculated as most suitable in the production of good records. In recording with the pianoforte many difficulties arise, more so than with other instruments, and as sales to a large extent depend upon the production of successful records, it is perhaps only natural that the pianoforte is not so widely used as one might wish for recording song accompaniments.

Having regard to the action mentioned above, it is rather significant, however, that an increasing number of records bear accompaniments with a piano in place of the usual orchestral setting. The latter is still regarded by manufacturers as the more desirable for record-making purposes, although one cannot really criticise the copyright owner's right to indicate in what manner his work shall be offered in record form to the public. It may be mentioned, however, that many copyright owners leave record makers free to choose the kind of accompaniment most successful for recording.

An instance of the new order of things is found in the latest Zonophone list, which contains no less than six vocal records with pianoforte accompaniment, as against two with orchestra.

Power of New Copyright Act.

The full scope and power of the copyright act is gradually being disclosed by new claims almost

every month. The latest is brought to light by Performing Rights, Ltd., recently established in the interests of British composers. It has started right in for the collection of fees from musicians performing at theaters, hotels, restaurants, kinema shows, seaside pavilions, etc. Controlling a number of big hotels, the Midland Railway Co. has made a contract for a yearly payment in respect of performances by hotel orchestras of the works of members of the society. The amount is said to reach three figures. To a newspaper reporter Mr. Towle, the manager of the Midland Co.'s hotels, said on the subject: "We think ourselves not too well treated, as our performances seem to us hardly performances of music for gain; but, of course, there is a legal point involved, which it would be long and costly to fight, so it seemed simpler to agree to the demand."

For the other side, P. Sarpy, secretary of Performing Rights, Ltd., said: "We are only getting for British musicians and publishers what foreign musicians have had for years past. England has been the only country where music makers were not organized for the purpose. Not all composers have joined us yet; but it is, I think, only a matter of time; already Paul Rubens, Lionel Monckton, Hermann Lohr, Howard Talbot, Hermann Finck and Archibald Joyce are members.

"I don't think there is any likelihood of the work of these popular composers being dropped because a fee is chargeable on performances.

"The fees will be strictly graduated in proportion to the size and importance of the establishment. We are exercising a legal right which has been in abeyance."

Favorite Record Co. Appoints Agent.

Some few months ago the Favorite Record Co. announced its intention to retire from this market and place its interests in the hands of an approved agent. The plan is now fait accompli, the new agent being the Utility Trading Co., of 21 Paper street, London, E. C. As representing the talking machine press of two continents, your correspondent was given some exclusive particulars of this departure at an interview with Mr. Gilbery, one of the directors of the Utility Co., who, by the way, has been actively interested in the gramophone business for some time past. Indeed Mr. Gilbery is an enthusiast, and, in common with his partner, Mr. Hessel, possesses unqualified confidence in the Favorite records and instruments, the market for which, it may be mentioned, is an expanding one in all directions. Said Mr. Gilbery: "Yes, we have been appointed sole sales agents of the Favorite goods for the United Kingdom. At the same time we shall not lose sight of the colonial market, which is quite open to us as selling agents. The present prices, i.e. 10-inch 1s. 6d.; 12-inch, 2s. 6d., remain unaltered. Of special interest, however, is the fact that all our new records will be recorded in England, and in future pressed at the Beka factory in Hertford, so that the Favorite record will be entirely of British manufacture."

Upon the policy of the company Mr. Gilbery said it would encourage a good class of trade and had in course of preparation for issue in August a fine de luxe list of titles by leading Continental vocalists and popular instrumentalists; this being quite apart from the ordinary issues, which would total not less than twenty-four new titles each month regularly. "We are out to fulfil all orders promptly," continued my informant, "and with that end in view have equipped our premises to hold enormous stocks of records, in addition to machines. Furthermore, we will follow this up by aiding dealers all we possibly can by the provision of good publicity literature, as a sample of which I may mention our new catalog, printed in three-color illustrations throughout." Another matter of important trade interest mentioned by Mr. Gilbery was his company's plans to cater for the cheap record business by the issuance of a

10-inch double disc at the competitive price of one shilling retail. This is expected to be ready within a few weeks, and further details as to name, etc., will then be announced.

Finally, I would take this opportunity of conveying to the Utility Trading Co. The World's hearty good wishes for the complete success of its new undertaking.

Chappell & Co., Ltd., vs. the Columbia Co.

In the Chancery Division on June 19 Justice Neville had again before him the test action brought by Chappell & Co., Ltd., song and music publishers, of Bond street, to restrain the Columbia Graphophone Co. from infringing their copyright in a song called "Where My Caravan Has Rested."

On May 19 His Lordship held that there had been infringement by the defendants, and granted plaintiffs an injunction. The matter now came up on a motion by the plaintiffs to vary the minutes of the judgment.

Mr. Jenkins, K.C. (for plaintiffs), said that in addition to the paper MSS. and band parts, the defendants had in their possession or control certain records made from these copies of plaintiffs' song. These, he submitted, were equally an infringement, and were restrained by the injunction, and the delivery up followed as a matter of course. They presumed on their pleadings that they would get everything that could be called a copy, and therefore did not specifically ask for the delivery up of the records. That was what they wanted now. The defendants had served notice of appeal, and it was common ground that it was likely to go to the House of Lords. Therefore they should like to have the point decided, as they desired to know where they were.

His Lordship—How can I decide it when it was never put to me?

Mr. Jenkins admitted that the actual relief to be given was never on record.

His Lordship—I cannot rehear it.

Mr. Jenkins—You can have it put in the paper for reargument. The point was not present to our minds.

His Lordship—If a thing has escaped the attention of the Court, you cannot have it put in by asking to vary the minutes. It must be set down for rehearing, unless you are agreed.

Gore Brown, K.C. (for defendants), said he wanted to consider the point. The plaintiffs never asked for an injunction restraining defendants from continuing the use of their records, but only copies of the MSS.

His Lordship—No, it was not considered.

Gore Brown—No case was made out for it.

His Lordship said he thought the point should be decided, and he would have the case put down for the point to be tried on a motion to amend the pleadings.

The matter was again argued on Tuesday, June 23, and in the result His Lordship said he thought that the records ought to be delivered up to be destroyed under the circumstances of this case. It seemed to him that the records were the product of a wrongful act, and that as such they could not be retained by the defendants. That he thought it was just as equitable to-day as before the act of 1911, but having regard to the fact that this was a test case he was of opinion that it would be better if the records were delivered into the hands of the plaintiffs' solicitors, to be held by them pending the result of the appeal.

Trouble Among German Combination.

The recently formed convention of German gramophone manufacturers, particulars of which have been published in our columns, is reported to be meeting with considerable opposition from firms outside the compact and from certain wholesalers and dealers. There is a possibility of a rival organization coming into existence for the purpose of combatting the growing influence of the conven-

(Continued on page 70.)

FROM OUR LONDON HEADQUARTERS—(Continued from page 69).

tion houses, and in addition certain concessions from the latter are demanded by the German Dealers' Association, which recently met to consider the convention agreement. The Hamburg section wants to know whether or not its members may handle Pathé products if Pathé Frères decide to remain outside the convention. Dealers who have in stock records other than those of the convention manufacturers seek to have them exchanged, one for one, for any of the latter's make on October 1. In addition, other minor requests are put forward by the dealers' association members in North Germany, to which the convention will doubtless reply in due course. Following the Hamburg discussion a general meeting of the association resolved that members would be ill-advised to sign the convention agreement in its present form. At this meeting considerable dissatisfaction with the convention in general was apparent. It remains to be seen what attitude manufacturers will now adopt in the face of this undoubtedly serious opposition.

J. Hoffay's Gramophone.

Pending the christening of J. Hoffay's new gramophone, the title applied to it pro tem., i. e. "The World's Musical Instrument," is becoming so familiar as almost to convince us that it should remain a permanent one. In any case we believe the description will continue as subsidiary to the chosen title. This latter we hope to announce in our next issue, when doubtless we shall also be in a position to satisfy the interest of our readers the world over by the publication of detailed particulars of this much-debated instrument. We are assured it is not the inventor's fault that a certain amount of secrecy is observed regarding its exact principle of construction and the method whereby such marvelously natural tone quality is possible, but the fact is that, pending the complete acceptance of the several patents covering this instrument, it is perhaps only natural that Mr. Hoffay should adopt this means of safeguarding his interests. From all parts of the globe inquiries have reached him through his announcements in this trade news-

paper, and as one might reasonably expect, Mr. Hoffay is anxious to publish definite particulars at the earliest possible moment.

At a second private demonstration of "The World's Musical Instrument" on June 11 I was agreeably surprised to note an improvement upon the first test of its tonal quality, wonderfully pure and faithful as that was in strength and detail. Questioned upon this, Mr. Hoffay laughingly admitted that he had made what he was pleased to describe as some little adjustments, but he remained severely mute as to their nature. Anyway, in its present shape I am of opinion the instrument will cause not a little astonishment in gramophone circles that such close alignment to art from the merely mechanical is not only possible but is fait accompli in Mr. Hoffay's invention. I write in no spirit of exaggeration, the opinion set forth here being the result of my own observation at the two demonstrations given me of this new gramophone.

Of the financial, manufacturing and sales arrangements, Mr. Hoffay informed me that everything is shaping out as he would wish, good progress having been registered in all departments.

New Companies Incorporated.

Blum & Co., Ltd., gramophone manufacturers; capital, £50,000. Registered office: 220 Old street, London, E. C. Dictators, Ltd., manufacturers of dictating machines; capital, £5,000. Office: 14 Red Lion Court, Fleet street, London, E. C.

Sound Transmitted Long Distance.

The strains of a gramophone were recently heard by a steamship when passing Vigo, and upon subsequent inquiry the officials found that the sound was transmitted by wireless from a private yacht over 200 miles away. Commenting on this report, Signor Marconi is stated to have said: "They were probably experimenting with a gramophone and a wireless telephone transmitter on board the private yacht. Tunes are transmitted and caught up in this way. I have never heard of it being done over such a long distance, but of course it is really quite feasible. From Marconi House in

the Strand I have sent gramophone tunes by wireless, telephony to my house at Fawley, near Southampton."

Not the Fault of the Columbia Co.

An unusually interesting item of news reaches me this month from the Columbia Co., which takes pardonable pride in announcing that no less than seven members of its staff contemplate marriage this year. With unerring aim Cupid has dispatched many arrows, but surely never so many in one comparatively little trading community as this. It pleases us mightily, and we hasten to extend to all the happy ones right hearty felicitations and general good wishes for their future prosperity and happiness. The full list is as follows: The Misses Maud Schindel, Hetty Durrant, Rose Green, and H. Moorby Smith, A. E. Norman, Sidney Hulme and D. O. Jeffery.

Advertising Summer Records.

"Hot Sellers for the Hot Weather" is the slogan used by the British Zonophone Co. descriptive of its excellent program of vocal and instrumental records for July. The description is well justified by the general high quality of the records in question, which bear a wide variety of suitable music by artists whose reputation alone is quite sufficient to insure a big demand for their record contributions.

Carl Lindstrom's Good Report.

At the general meeting of Carl Lindstrom, A.G., at which, by the way, a dividend of 15 per cent. was approved, the chairman gave voice to some significant words regarding the fluctuations of record prices. To check this the board had decided to join the Deutsche Grammophon, A.G., and other principal makers, in the convention. With the same object in view they had absorbed the business of Dr. Grünbaum & Thomas, embracing the taking over of the Favorite concern, Linden, Hanover, and arrangements now carried out would, in the opinion of the board, eliminate any necessity for further amalgamations. It is common property that the Lindstrom people now control a big pro-

(Continued on page 72.)



To T.M. the King and Queen of Spain



To H.M. the King of Sweden



To H.H. the Khedive of Egypt



To H.M. the King of Italy



To H.M. the Shah of Persia



By Appointment To H.M. Queen Alexandra

"His Master's Voice"
—the trade-mark that is recognised throughout the world as the
Hall-mark of Quality

AUSTRIA: Oesterr. Grammophon-Gesellschaft, m. b. H., 8, Krugerstrasse, Vienna.
BELGIUM: Cie. Française du Gramophone, 51, Avenue de la Porte de Hal, Brussels.
DENMARK: Skandinavisk Grammophon-Aktieselskab, Frihavnens, Copenhagen.
FRANCE: Cie. Française du Gramophone, 115 Boulevard Richard Lenoir, Place de la République, Paris.
GERMANY: Deutsche Grammophon-Aktiengesellschaft, 35, Ritterstrasse, Berlin, S42.
HOLLAND: American Import Co., 22a, Amsterd. Veerkade, The Hague.
HUNGARY: The Gramophone Co., Ltd., IV, Kossuth Lajos-Utca 8, Budapest.
SPAIN: Cia. Francesa del Gramophone, 56, Balmas, Barcelona.
SWEDEN: Skandinaviska Grammophon-Aktiebolaget, 52, Appelbergsgatan, Stockholm.

RUSSIA: The Gramophone Co., Ltd., 45, Nevsky Prospect, St. Petersburg; 9, Golovinsky Prospect, Tiflis; 30, Novia Svit, Warsaw.
EGYPT: The Gramophone Co., Ltd., 13, Rue Stamboul, Alexandria; Rue Mousky, Cairo.
EAST AFRICA: Bayley & Co., 8 Beira, Lourenço Marques.
SOUTH AFRICA: Darter & Sons, Adderley St., Cape Town; Mackay Bros., Rissik Street, Johannesburg; Mackay Bros. & McMahon, 443, West Street, Durban; Ivan H. Haarburger, Maitland St., Bloemfontein.
INDIA: The Gramophone Co., Ltd., 139, Ballighatta Road, Calcutta; 7, Bell Lane, Fort, Bombay.
AUSTRALIA: The Gramophone Co., Ltd., Hoffnungs Chambers, Pitt Street, Sydney.
GREAT BRITAIN: The Gramophone Co., Ltd., 21, City Road, London, E.C.

Great Britain:

The Gramophone Company Ltd
21 City Road London EC



[Patents Granted or Pending the World Over.]



“The World’s Musical Instrument”

PLAYS to *equal* perfection every disc record ever made, band, instrumental, orchestras, string organizations, tenor, baritone or bass; soprano, mezzo or contralto—irrespective of the make of the record or “cut” of same.

PLAYS Columbia, Edison, His Master’s Voice (Victor), Marathon, etc., records without additional attachments or change of sound boxes.

PLAYS to suit the small room or the large hall (without additional attachments or closing “doors”) and *its tone* is absolutely the same in every case.

BRINGS *independence* and *more profits* to dealers.

BRINGS increase of record sales to *all* manufacturers.

SOON READY

J. HOFFAY

67 Egerton Gardens, South Kensington, London, England

"MIRACLES HAPPEN EVERY DAY"

That is what an old Philosopher said, and it is certainly true in our case.

The Miracle we have perpetrated is in producing Gramophones and Records in such extraordinarily marvellous qualities and at such astounding low prices as to compel Talking Machine men to say emphatically that we "have wrought a miracle."

For instance, we can supply a Gramophone with an Oak Case, measuring about 13 x 13 x 6½ inches high, with Tapered Tone Arm, a Crackerjack Sound Box, 10-inch Turn Table, and a Motor to run one 12-inch Record good, for the low price of \$2.50. Further, we give a year's unequivocal guarantee with each. We have other machines which cost more money, and they're all of "Top-Notch" value.

The charm of the Gramophone or Talking Machine is in the variety of Records which one can obtain. Now let us send you some of our Double-Sided 10-inch "DIPLOMA" or "PIONEER" Records, which regularly sell here for 37½ cents each. Our price to you is a terrific cut on that. Or, if you can give a big enough order, we will make you records with your own label thereon.

We make and sell everything for the Talking Machine Factor or Dealer, so why not write us now and get our Record Lists and Illustrated Catalogue of Machines. Don't pay fancy prices. Don't pay for Expired Patents. Don't pay for Names. Just pay for the goods and the intrinsic value of them. Our goods sell all the time just as well as the much-boasted ones, because Talking Machines, when all is said and done, "Speak for Themselves."

WRITE RIGHT NOW

BLUM & COMPANY, LIMITED

Manufacturers

Offices and Showrooms: 220 OLD STREET (Corner of City Road), LONDON, ENGLAND

Cables: Blumogram, London.

Codes: A. B. C., 4th Edition, Western Union, Reuters, Liebers.



FROM OUR LONDON HEADQUARTERS—(Continued from page 70).

portion of the record trade on the Continent, and one may reasonably expect that this fact, in conjunction with the policy of the manufacturers' convention, will go far to regulate prices and place the gramophone trade in Germany on a healthier footing.

Records by International Artists.

A grand list of new records by international artists is announced by "His Master's Voice" Co. The list makes a timely appearance, coinciding as it does with the performances of these famous singers in London. Melba, Caruso, Chaliapin, Frieda Hempel, Destinn, Amato, Martinelli, Kirkby Lunn, in addition to Titta Ruffo and Cicolini, contribute to the list some really exquisite records which all operatic lovers should not fail to hear.

Records of "The Passing Show."

The latest London revue, "The Passing Show," now being played at the Palace Theater, offers many attractive numbers, which "His Master's Voice" Co. was quick to appreciate as good material for recording. Seven fine records is the result, two orchestral, one by the Light Opera Company, one by Basil Hallam, two by Miss Elsie Janis, and last, but not least, one as a duet by these popular vocalists. It is said that the Palace authorities doubted whether Miss Elsie Janis' big American salary could be made "good" here. The public decided, and that American salary has been paid very willingly ever since she captivated her first audience.

Good Business Report.

Brown Bros., Ltd., the big cycle and gramophone manufacturing house on Great Eastern street, this city, announce particulars of their balance sheet, which discloses a very healthy condition as regards last year's trading. The report is as follows: "After making provision for depreciation of leaseholds and fixtures, the profit for the year to December 19, 1913, is £26,938. It is proposed to pay a dividend of 7½ per cent., free of tax, on the ordinary shares, to place £5,000 to reserve (making

it £50,000), and to allocate £306 to depreciation of investments, to bring them to market value, carrying forward £15,618, against £15,429 brought in."

To Introduce New Record.

The "Ajax" is a new record to be placed on this market at the retail price of one shilling. It is 10-inch double-sided, and will sell under fixed price maintenance conditions. The first list comprises some 350 records, and new supplements will be issued regularly each month.

"Casse-Noisette" Suite on Columbia.

A special supplement announces the issue of four Columbia-Rena 12-inch records, comprising the complete "Casse-Noisette" Suite of Tchaikowsky. With its invariable rule of "doing the thing properly," the Columbia has issued the Suite in an artistic album containing an art print of the composer and details of the numbers making up the Suite. The Suite is a collection of the pieces written for the fairy scenes, and consequently abounds in light and delicate melodies in keeping with the fairy setting. It contains eight distinct numbers:

1. Miniature Overture.
2. Marche.
3. Dance of the Sugar-Plum Fairy.
4. Russian Dance, "Trepak."
5. Danse Arabe.
6. Chinese Dance.
7. Danse des Mirlitons (reed-pipes).
8. Valse des Fleurs.

These Columbia records were specially recorded by the justly famed orchestra of the Palace Theater, London, and conducted by Hermann Finck, the composer of "In the Shadows," etc., who has done so much to raise the standard of music in London variety theaters.

Budget of New Records.

Leo Ornstein, the nineteen-year-old pianist who attained quite some notice in London during the past two months, has made a record of two piano Classics, Grieg's "Butterfly" and Poldini's "Marche Mignonne." These are in the Columbia-Rena 10-inch record list this month.

Charles W. Clark, the prominent American baritone, is another newcomer in the Columbia list, having made records of two sacred numbers for

the Columbia De Luxe series. Alice Zeppilli is also represented in the Columbia list this month, coincident with her appearance at Covent Garden.

The Columbia Supplementary List for July in its design makes an interesting departure, the two-color illustration on the cover depicting a scene from "Parsifal," and thus pertinently drawing attention to the two records of the opera which lead off this list. These records, by the way, have been especially recorded by the Milan Symphony Orchestra, under Maestro Romani, and, coming at a time when "Parsifal" has met with renewed success at Covent Garden, make an opportune appeal. It is interesting to observe that the writer of the descriptive notes concerning these new Columbia issues remarks that "'Parsifal,' to be appreciated musically, must be approached with a mind free to receive impressions, its moods and motives are so varied, yet withal so clearly defined, that, heard in a receptive spirit, the music cannot fail to make a profound impression."

A remarkable record of two splendid grand opera choruses finds a place among the Columbia-Rena 10-inch records this month—the "Soldiers' Chorus" from "Faust," and "Lombardi," Pilgrim's Chorus.

"The Cinema Star" is the title of the new play by Jean Gilbert at the Shaftesbury Theater. Its original title is "Kinokonigin," which, when produced in America, was changed to "Queen of the Movies." It is from the "Queen of the Movies" that two vocal selections appearing on the Columbia-Rena July list are quoted. One of them, "In the Night," we already know here instrumentally, it having been a very popular orchestral selection for some months past, but this is, we believe, the first vocal record of the charming air. The other, "Oh, Cecilia," is a vocal setting of a light and jingly one-step tune.

H. Lane Wilson's third record is listed in the Columbia-Rena July Supplement, and his commanding voice will be highly appreciated both in the fine character song, "Brian of Glenaar," and the old English air "Twankydllo."

Phones { 5048 } London Wall.
 { 5049 }

RECOVERS RAPIDLY FROM THE EFFECT OF BIG FIRE.

The New York Talking Machine Co., with Indomitable Energy and Enterprise, Conquers Damage Caused by Great Fire Which Visited It on Chambers Street, June 21—Shipments Being Made in Regular Order—Will Get Back to Old Home Shortly.

A fire which started at 4 p. m. Sunday, June 21, and lasted for nearly two hours destroyed over 170,000 Victor records and about 1,500 Victrolas and Victor machines which were stored in the basement and sub-basement of the New York Talking Machine Co., 81 Chambers street, New York, one of the largest Victor distributors in the country. The fire was one of the wickedest that the New York firemen have encountered for some time, and the fumes of various poisonous substances and leaking gas overcame nineteen fire fighters, who were restored to consciousness through the use of the pulmator and other modern appliances. No lives were lost in the fire, which, it is thought, was started through defective insulation. Both the company's stock and the building it occupied are fully covered by insurance.

The New York Talking Machine Co. occupied the store floor, basement and sub-basement of the building at 81 Chambers street, all three floors running through to 63 Reade street. The store floor was devoted to the company's executive and sales offices, while the lower floors contained the stock, shipping and repair departments. The company also utilized as a warehouse for additional stock a floor in the building at 77 Reade street.

The length of the floors, together with the inflammable nature of the stock, handicapped the firemen from the very start of the fire, and the damage wrought by water exceeded that caused by the flames. The lower floors were completely destroyed, while the store floor was considerably damaged and the demonstration booths flooded with water.

Arthur D. Geissler, vice-president and managing director; G. T. Williams, manager, and V. W. Moody, sales manager of the company, were advised of the fire as soon as it started, and were on the scene before the firemen had it under control. Together with other members of the sales and office staffs they labored indefatigably through the greater part of the night, and on Monday morning announced that they had secured temporary quarters at 77 Reade street, where they would be doing business before the close of the day.

All of the books, stock records and accounting paraphernalia had escaped the ravages of the fire, and were removed at once to the new quarters.

With indomitable energy the officers and staff worked incessantly putting the new offices in shape by Tuesday morning. Shipments of machines and records were started at once and have continued since that time. The company's surplus stock at 77 Reade street was a salvation, and Vice-President Geissler availed himself of some of the hearty offers of assistance which were extended to him by Victor distributors in all parts of the country, who sent telegrams offering all possible help as soon as they learned of the fire.

The July records were sent out to the company's dealers on schedule time, and the aggressiveness of the staff is well exemplified in the

hustling activity that is now apparent in the Reade street quarters.

The record stock is rapidly being replaced, and at the present writing is almost as large as it was before the fire. Machine shipments are being received daily, and, in short, the company has recovered with exceptional rapidity from a fire which would dishearten the most optimistic business man.

The space now occupied by the company includes the store floor, cellar, sub-cellar, third and fourth floors of the building at 77 Reade street and lofts in buildings at 63 Reade street and 9 Murray street. A portion of the executive staff and the showrooms remain at 81 Chambers street, the home of the company, where a force of workmen are working day and night to remove the wreckage from the three floors.

When seen by a representative of The World the day after the fire Mr. Geissler said: "This fire has been, of course, a severe blow, but we are now making shipments from our temporary quarters and can assure our dealers that our service will continue without interruption. We have already started to rebuild the floors which were destroyed, although we do not expect to be back in our building for the next few weeks. Shipments of records and machines are being received daily, and the assistance offered us by Victor jobbers throughout the country is greatly appreciated.

"Our safes and records all remained intact, and we are utilizing every possible means to give our dealers the prompt service to which they are accustomed. Our surplus stock at 77 Reade street has enabled us to continue shipments with only a few hours' interruption, and we wish to thank our dealers for their hearty co-operation."

BUILDING UP A LARGE BUSINESS.

(Special to The Talking Machine World.)

INDIANAPOLIS, IND., July 6.—One of the aggressive representatives of the Victor lines, which gets its goods through the jobbing house of the Stewart Talking Machine Co., is the Holloway-Wright Co., of New Castle, Ind. This company's main line is furniture, but the talking machine line is not neglected. Instead, the Holloway-Wright Co. figures that in pushing the talking machine line it not only increases its sales in that line, but gets customers for its other lines. The company has been arranging very fine Victor windows.

NEW OFFICE BUILDING FOR VICTOR CO.

The Victor Talking Machine Co. has just had plans prepared for the erection of an eight-story office building, 75x150 feet, which will house the executive offices and clerical departments of the company's business. The new office building is expected to cost in excess of \$50,000.

The New Brighton Talking Machine Co. is the title of a new concern in Beaver Falls, Pa.

A Great Business Opportunity

Are you looking for opportunities to increase your net profits?

Are you interested in lines which blend satisfactorily with talking machines which will add materially to your business success?

If you are, we can help you, and the sooner you get in communication with us the more rapidly your profits will accumulate.

Do you realize how splendidly pianos and player-pianos blend with talking machines?

We have created one of the largest manufacturing enterprises in the world in a short space of time, and we have done it through the delivery of values.

We are in a position, through our unexcelled factory facilities, to supply you with pianos and player-pianos at prices which will enable you to make splendid profits.

Our instruments are reliable in every particular, and our prices will appeal to people of moderate means.

Let us take up this subject with you.

It will pay you!

H. P. NELSON COMPANY

Makers of Grands, Uprights and Player-Pianos

North Kedzie, North Sawyer, West Chicago Aves. and C., M. and St. Paul R. R., CHICAGO.

Triumphon Co., Ltd., Berlin, S. W. 47/5

Established 1884

Manufacturers

Of All Accessories

Such as

Motors, Soundboxes, Tone Arms

Complete Talking Machines

APPLY FOR CATALOGUES

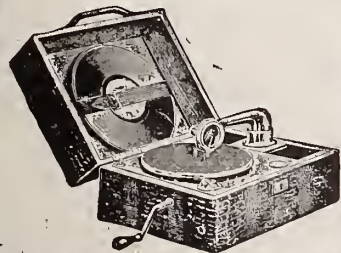

Piccolo is a complete Talking Machine. Easily to be carried like a portmanteau. Most suitable for picnic or rover parties in summer, and easily carried to social gatherings in winter. Plays 12-inch records. Is not a toy. Weight without records, only 5 kg. Measurements: 11 x 13 3/4 x 7 3/4 inches.

Special Motors**HYDRA SYSTEM**

Single and double spring, six different models. Are the only existing construction which allows the exchanging of the spring and spring case without taking the motor out of the cabinet. After loosening one nut, a child is able to replace any defective spring or springbox within 20 seconds.

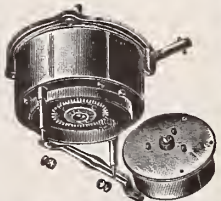

Patents Applied for.



If by any chance you haven't heard the four Columbia Instruction Records, you've missed something.



(Write for "Music Money," a book "full of meat" for those dealers interested in quick and frequent turnover of capital.)

Columbia Graphophone Company
Woolworth Building, New York

MAKING THE STEEL NEEDLE ARM.

An unusual photograph is shown herewith, depicting the process of making the steel needle arm used on the products of the Columbia Graphophone Co. As explained by operations, this photograph shows the following:

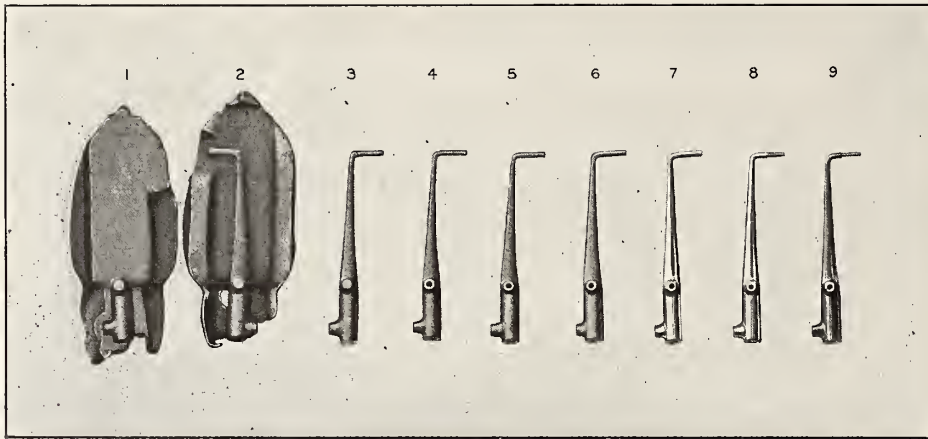

Evolution of the Columbia Steel Needle Arm.

1. Shows first operation to form needle holder end under drop press.
2. Shows second forming which completes the outline of the needle arm under the drop press.
3. Shows the third operation in trimming press, cutting away all surplus metal.
4. Shows fourth operation of drilling the four

holes and tapping for the needle-holding screw.

5. Shows the broaching for the triangular hole for the fibre needle.
6. Shows the rough polishing and grinding.
7. Shows the finishing, polishing and buffing.
8. Shows threading on small end of arm for nuts that hold the diaphragm.

cessful piano house will open a new department for the exclusive presentation of Edison disc products. This department is now practically completed and includes all modern perfections for the comfort and convenience of patrons. Miller Bros. but recently moved into new quarters, which give them increased space and facilities for handling their fast growing business.

TWO YEARS OF PROGRESS.

Thos. W. Kirkman, Manager of the Standard Gramophone Co., Tells of Growth in Popularity of Various "Standard" Specialties.

"It is now two years since we first introduced our automatic stops at the Atlantic City convention," said Thomas W. Kirkman, manager of the Standard Gramophone Appliance Co., 173 Lafayette street, New York. "The automatic stop that we introduced at that time was the well-known 'Simplex,' and the practical nature of this stop was an important factor in its emphatic success. During the past two years the market for automatic stops has steadily increased, and to fill the demand that exists for automatic stops at a nominal price we perfected our 'Standard' stop, which is every bit as effective as our 'Simplex,' and which, in the short time it has been on the market, has achieved country-wide popularity.

"About a year ago we decided to market our 'Standard' fibre needle cutter, which we had had in course of perfection and manufacture for nearly a year. The labor and expense we had bestowed on the preliminary details of this cutter practically insured the success of this accessory, and the sales of this cutter have grown so rapidly that we are now devoting a separate department of our business solely to its manufacture. We have a special department where every cutter is tested by actually taking a number of cuts on a fibre needle.

"The most gratifying feature of our business the past few months, however, was the remarkably cordial reception accorded our 'Standard' record cleaner, as the orders received for this cleaner have been so heavy that we have been obliged to run two presses constantly to handle the demand.

"As we consider this convention a second anniversary, we wish to thank the trade for its generous and hearty co-operation and appreciated patronage during the past two years."

Mr. Kirkman also remarked that the company had recently consummated a deal to double its available manufacturing space by leasing another entire floor in its present location.

UNIQUE CABINET EFFECT.

The Victrola section of the New York store of John Wanamaker, Eighth street and Astor place, introduced something new this month in the nature of a Victrola on wheels, designed especially for summer use. This unique combination consists of a Victrola IX, which retails at \$50, with a wheel cabinet that permits of the convenient moving of the Victrola from one part of the house to the other. The cabinet portion of the arrangement contains racks for the usual number of records. The complete wheel-cabinet retails at \$75.

Special

Send for a package of our Improved Half-Tone and Loud Tone Needles in New Style Envelopes.

If you want to advertise yourself, we will put your own name or trade-mark on the envelopes, or will pack in Puritone envelopes.

Quality Guaranteed

The Best Needles mean profit and satisfaction.

If you want to sell 1,000 Needles at a time instead of 100, use the "Dean-packed" Needles. Five boxes of 200 each, Extra Loud, Loud, Opera, Medium and Soft packed in a carton. The best package and fastest seller on the market. Write for samples.

JOHN M. DEAN, CORP.

Talking Machine Needle Manufacturers

PUTNAM, CONN.

HIGHER RANGE OF PRICES PREVAILS IN DETROIT

For All Makes of Talking Machines—The Demand Now Is from \$100 Up—June Trade Somewhat Slow in Detroit—Special Store for Hudson Co.—Bayley Discusses Salesmanship of Pianos and Talking Machines—Looking Forward to a Large Fall Trade.

(Special to The Talking Machine World.)

DETROIT, MICH., July 8.—June was not a very good month for the talking machine business in Detroit. In fact, it was the dulllest summer month in a long time. This was somewhat of a surprise, for generally Detroit is a good summer town for the business, because talking machines are in demand for yachts and boats of all kinds and for the thousands of summer cottages which are established on lakes, islands and rivers within a radius of thirty or forty miles from the city.

There is no reason for the slackening, for business in the city is good. Real estate is booming, new business buildings, hotels and factories are being erected, including a doubling of the already mammoth Ford plant, and residences by the thousand are being built. Contracts indicate an even more active month in July. All this makes jobs for workmen and business for commercial enterprises of all kinds. So the falling off in talking machine sales is regarded as but momentary, and due to the inexplicable "luck" which causes short periods of dulness in any line of business occasionally, always to be followed by greater activity than ever. As a matter of fact, business is not bad—simply not as good as it has been in other summers.

That confidence in the situation is unshaken is evidenced by the fact that the largest houses already are looking forward to the fall trade, and providing for it by placing big orders with jobbers for early delivery. One house paid spot cash, in the first week in July, for \$10,000 worth of Victrolas for delivery this month. The same house is placing orders with other jobbers.

Range of Prices Working Higher.

The range of prices seems to be working higher than ever. The fashionable demand now is from \$100 up. A year ago it was from \$75 up, and two years ago the \$50 styles marked the dividing line between the active machines and those only desultorily sold. The answer seems to be that a better class of people, that is, a better-off financially class, than ever are buying them. They want the finest cases as well as the finest tone. This class of trade augments the record sales materially, for talking machine owners who have wealth do not hesitate to select liberally of the new catalogs. If in doubt, they take it, and if they don't like it particularly they throw it away. Several weeks ago a wealthy Victrola owner purchased a big bunch of records. A daughter entertained a party of young people with them. As she finished playing them she laid them on top of a steam radiator, where they remained all night. In the morning they were warped out of shape. So pater bought another cargo. Of course, the dealer didn't mourn, particularly.

"Whereas a few years ago wealthy people would not have a phonograph in their basements, or

anywhere else, now they are placing them in their front parlors, and entertaining their most honored guests with them," said this dealer. "The talking machines are becoming more and more educational. The fact that classical records of the best standard can be obtained at any time is weaning people from ragtime. After they have been accustomed to the best music they decline to listen to ragtime at all. In these days people of refined tastes cannot get away from the sound of ragtime altogether, no matter how hard they try. It is heard on the streets, in hotels, in parks and summer resorts and in theaters. Educated people detest most of it. The talking machines give them their own selection of good music. Moreover, the talkers educate them more and more to prefer the good music. The records render the good music properly. People know that it is properly rendered, and accept the renditions as a standard of excellence. People of education like this excellence, and people who desire to acquire musical education want it to teach them. That is why trade trends continually to higher levels."

Attending the Jobbers' Convention.

Harry Rupp, manager of the talking machine department of Grinnell Bros., and Max Strasburg, of the Max Strasburg Co., are in the East in attendance at the annual convention of the talking machine jobbers at Atlantic City. Mr. Strasburg is en tour in a motor car. He traveled by boat to Buffalo, then took to the motor roads. Besides Atlantic City he will visit Philadelphia and Washington. He will be gone a month. Mrs. Strasburg is with him. When Mr. Strasburg was manager at Grinnell Bros. a few years ago he was a member of the association, and he is now anxious to renew old acquaintances for a day or two.

Important J. L. Hudson Co. Move.

The talking machine department of the J. L. Hudson Co. will be in a separate building with the pianos again next year instead of on certain floors of the main building. The Hudson Co. has acquired another building especially to house its music trade departments, it having been decided that this would be more appropriate and better business than losing the individual identity of the store in a much larger establishment.

As a matter of fact, the piano and talking machine business of the company is very large. Standing by itself, its magnitude is instantly apparent to all, and prestige in accordance with its merit is conceded it. But merged with a great general store its magnitude is lost.

Also, a ground floor location and show windows are now generally recognized as indispensable. This is especially so of small trade, and in the talking machine business the sale of records is a very large item. People want to buy them

handily. If one store has them on upper floors and another on the ground floor, the latter will get the trade. To a large extent the same is true of the talking machines themselves. If a nice talking machine is displayed in a window, and the people who are attracted by it can just step inside and see a lot more of them and hear them without trouble, they are much more apt to buy.

The building is five stories in height, has thirty feet frontage on Woodward avenue, in the very best location, and will be fitted up regardless of expense. The talking machine business is recognized by the company as a most profitable enterprise, and every facility will be provided for its efficient transaction.

Bayley Discusses Edison Phonograph Addition.

Frank J. Bayley, who recently added the Edison line of talking machines to his piano business, is rapidly becoming proficient in his new line of salesmanship. "It's easier than selling pianos," he remarked. "While there isn't as much profit in a single deal, we make more deals, and in proportion to the amount involved we get much better terms. Consequently it does not require so large an investment to make a given profit. Then, it adds variety to the business. Every piano house ought to have the talkers on hand. Often we find that people who come in for the purpose of buying a piano cannot find exactly what they want, either in price or instrument, and we interest them in the talking machines and make a sale. It is business we would have lost entirely without the phonographs. I sometimes wonder why I failed to consider this long ago, and did business so many years without them."

INTRODUCE TWO NEW ALBUMS.

The New York Album & Card Co. Tells of Latest Addition to Its Line—Report an Excellent Demand for Its Various Products.

The New York Album & Card Co., Inc., 23 Lispenard street, New York, the well-known manufacturer of talking machine record albums, has just added two new albums to its already comprehensive line which should prove valuable additions. These new albums consist of a new 12-pocket album which is particularly adapted for use in the new cabinets with flat shelves and an album for holding Edison disc records. This latter style is made like the regular albums turned out by this company, except that it is spaced wider and has ten pockets. Both of these new albums have won praise from all of the company's customers, who predict a splendid sale for them.

George Bates, secretary of the company, stated in a chat with The World that the various products manufactured by the New York Album & Card Co. are meeting with pleasing success throughout the country, notwithstanding the general business depression. Mr. Bates remarked on the widespread popularity of the company's flexible cover designed to hold the semi-annual record catalogs, which, he states, is one of the most successful articles the company has yet introduced.

BE WITH THE LIVE ONES!

Beka Records

IN ALL LANGUAGES OF THE WORLD

High grade selections in

German, English, Italian, Spanish, Portuguese, French, Swedish, Slavonic, Ruthenian, Danish, Norwegian, Russian, Polish, Hungarian, Bohemian, Rumanian, Tschechisch, Croatian, Servian, Hebrew, Turkish, Persian, Arabic, Chinese, Malay, Japanese and seventeen different Indian dialects.

The cheapest and best machine on the market for \$2.50 upward

BEKA-RECORD AKT. GES., Berlin, S. O. 36 (Germany)

CATALOGUE IN FOUR LANGUAGES SENT FREE ON REQUEST

LATEST PATENTS RELATING TO TALKING MACHINES AND RECORDS

(Special to The Talking Machine World.)

WASHINGTON, D. C., July 8.—PHONOGRAPH.—Alexander N. Pierman, Newark, N. J. Assignor to New Jersey Patent Co., West Orange, N. J. Patent No. 1,097,989.

This invention relates to phonographs and allied talking machines and particularly to improvements in the lever which carries the reproducer ball or point. In the reproduction of sounds by means of a phonograph it is of the utmost importance that the vibrations imparted to the stylus in its travel over the minute undulations of the record surface be faithfully transmitted to the diaphragm without any change whatever due to foreign causes, such, for example, as lost motion. Since the extreme width of the record groove in the standard phonograph record cylinder is not over one one-hundredth of an inch and it does not exceed in depth one one-thousandth of an inch, it is evident that the slightest lost motion will affect very seriously the reproduction of sound, and this is the more true because it is the practice in instruments of this type to amplify the vibrations of the stylus which are imparted to the diaphragm which results also in multiplying any lost motion which may be present. This amplification is usually accomplished

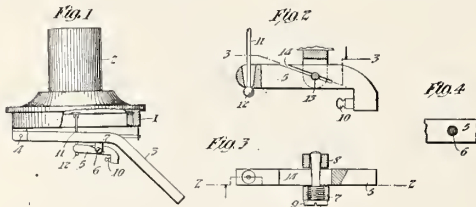

by mounting the reproducing ball or point on the shorter arm of a pivoted lever the opposite and longer arm whereof is connected to the diaphragm. In this art the reproducing ball or point is often termed the reproducing stylus, and for convenience of reference the lever carrying the same is hereinafter called the stylus lever.

It is the object of this invention to provide a stylus lever for the phonograph so constructed that all possibility of lost motion due to the pivoting of the said lever in its support shall be overcome.

In order that the invention may be fully understood, attention is directed to the accompanying drawing wherein the same reference numerals are applied uniformly to the same parts, and in which

Fig. 1 is a view in side elevation of a phonograph reproducer equipped with this improvement, and Figs. 2, 3 and 4 are sectional detail views, Fig. 2 being taken on the line 2—2 of Fig. 3 and Fig. 3 being taken on the line 3—3 of Fig. 2.

ATTACHMENT FOR SOUND-REPRODUCING INSTRUMENTS, Sylvain Dayan, Montreal, Quebec, Can. Patent No. 1,095,195.

This invention relates to attachments for sound-reproducing machines, and more particularly for gramophones of a type similar to the Victor.

The object of the invention is to provide a jointed tube adapted to be inserted between the sound box and goose neck, so that the sound box may be suitably adjusted to use either steel or sapphire needles.

A further object is to provide a device of this character which will not require to be removed each time a change is made from steel to sapphire needles.

There are several important recognized principles in connection with sound reproduction which must be thoroughly understood before the full importance of the present invention becomes apparent. First it must be understood that the disposing of the diaphragm or sound box, whatever the character of the needles used is dependent upon the nature of the record groove, whether vertically undulatory or laterally undulatory, that when using either steel or sapphire needles, the best results are obtained when the needles are arranged at an angle of approximately forty-five degrees to the record groove, that the arc of movement of the needle should pass through the axis of rotation of the

record. In other words, a line drawn through the axis of rotation of the tone arm and the needle point should be at all times substantially tangent to the grooves of the sound record. The drag of the moving record on a properly placed needle has absolutely no tendency to move it either toward or away from the record center and therefore the needle presses equally against each side of the record groove. If, however, the needle is placed

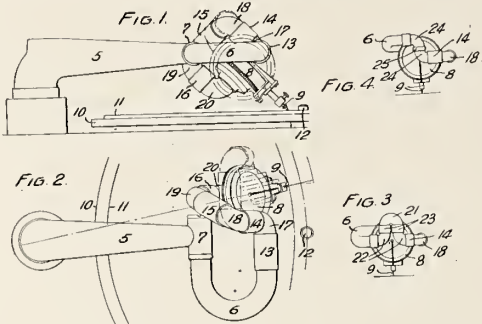

on the opposite side of the record axis from the tone arm axis, the needle will drag against the inner walls of the record grooves and be uncertain in action. The pressure of the needle, however, upon the groove walls when the needle is located between the record and tone arm axes is the same for the same distance from the axis, but in opposite direction.

This invention consists in providing a flexible tube made of relatively revoluble sections connected by elbows adapted to be permanently inserted between the goose neck and sound box, so that the sound box may be arranged in any position and the needle adjusted to any angle for playing with either steel or sapphire needles, and may be adjusted either inside or outside of the record center, so that the needle will press against one side or the other of the record grooves to overcome centrifugal force and to correct any skipping tendency.

In the drawings which illustrate the invention Fig. 1 is a side elevation of the device in operative position, showing in full lines the adjustment for using a sapphire needle, and in dotted lines the adjustment for using a steel needle. Fig. 2 is a plan view corresponding to Fig. 1. Figs. 3 and 4 are front elevations of slightly modified forms of the device.

TALKING MACHINE.—Giuseppe di Stanislao, Camden, N. J. Patent No. 1,095,747.

This invention has for its object to provide a device in which the different supports, the horn, a number of records and other accessories used in the playing of a talking machine may be held in the casing and cover thereof, making a relatively small compact package, permitting the same to be readily transported from place to place in a single covering.

A further object of the invention is to provide a collapsible bracket or support for the horn which may be readily placed in the drawer of the casing or cabinet.

A further object of the invention is to provide an adjustable rest for the smaller end of the horn in order that the reproducer may be held out of

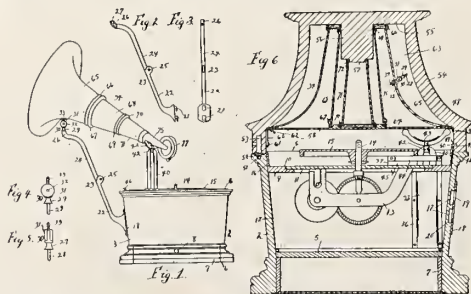

contact with the record disc or turn table while the needles are being changed or when the machine is not being played.

Another object of the invention is to produce a sectional horn, the sections of which may be taken

apart and telescoped one in the other within the cover of the cabinet.

Figure 1 is a side elevation of the improved talking machine, the cover of the cabinet being removed and showing the horn engaging the rest. Fig. 2, a side elevation of the horn support or bracket, a portion thereof being broken away to clearly illustrate the construction. Fig. 3, a similar view at right angles to Fig. 2. Fig. 4, a side elevation of the hinged or pivot number for mounting the horn upon the bracket. Fig. 5, an edge view thereof. Fig. 6, a vertical sectional view of the cabinet and cover thereon, showing the horn in said cover and illustrating the position of the different parts when the machine is ready for transportation. Fig. 7, a side elevation of the horn disconnected and having portions thereof broken away to clearly illustrate the construction. Fig. 8, a vertical sectional view of a portion of the cabinet, showing an edge view of the rest. Fig. 9, a similar view illustrating the front elevation of the rest, and Fig. 10, a perspective view of one form of cover or carrying case.

TALKING MACHINE.—Eugene Earl Norton, Bridgeport, Conn., assignor to James Albert Whitman, New York. Patent No. 1,095,225.

This invention relates to talking machines, and especially to propelling devices for the sound boxes thereof.

The invention is distinguished by a propelling device for disc records, having up and down cuts. The records are distinguished from the zig-zag records, where the variations are in horizontal planes, while the records for which this invention is applicable have surfaces inclined to horizontal

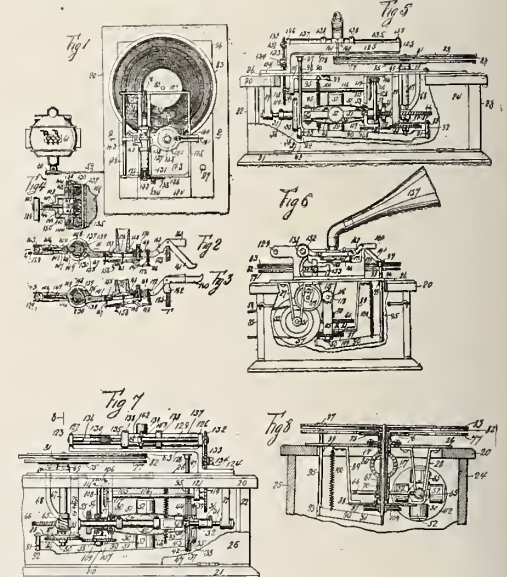

planes. The sounds with this device are produced by the contact of the needle point with said inclined surfaces, and the mechanism of the invention propels the point across the horizontal plane of the records.

The invention also relates to means for rotating and instantly starting or stopping the disc carrying the disc record.

In the accompanying drawings Fig. 1 shows a top plan view of the invention, Fig. 2 represents an enlarged partial section of Fig. 1 on the line 2, 2, Fig. 3 is similar to Fig. 2 with some of the elements in a changed position, Fig. 4 is a partial section as on the line 4, 4 of Fig. 2, Fig. 5 is an enlarged right-hand view of Fig. 1 with a portion of its case broken away, Fig. 6 shows a left-hand view of Fig. 5, Fig. 7 represents a left-hand view of Fig. 6 with the case broken away, and Fig. 8 shows a section of Fig. 7 on the line 8, 8.

GRAPHOPHONE.—John A. Weser, New York, N. Y. Patent No. 1,100,107.

It has been proposed to control the operation of

LATEST PATENTS RELATING TO TALKING MACHINES—(Continued from page 76).

a graphophone by means acting automatically and in proper sequence whereby the proper starting and stopping thereof is effected and different records successively placed in operative position. Such means have usually been mechanically connected to the actuating mechanism of the disc turn table, and once the device was set in motion various controlling devices had to perform their respective functions before a different record could be placed in position and the parts reset. Further, in these prior devices it was not possible to repeat a portion of the composition on the particular record in operative position. The transfer of records in such arrangements has usually been effected by the bodily movement of suitable frame supports therefor, and the means to effect the movement of the frames when desired have necessarily been too complicated and delicate for general use and did not admit of the application of the devices to any graphophone. Further, the control mechanisms have never been so related to each other and to a common source of power that those movements which should properly be co-ordinated and yet independent of other sequential control movements could be initiated independently. Neither has any arrangement been provided to permit the operations of a graphophone to be controlled from a distance by an attendant.

Accordingly, it is an object of this invention to overcome the disadvantages hitherto encountered in automatically controlled graphophones and to provide a machine which shall be of comparatively simple construction, substantial in its nature, of relatively few moving parts, inexpensive to manufacture, invariable in its operation, susceptible of control at all stages of its operation and at a distance, and generally of a character which shall commend itself to users of all classes.

A further object is to construct the controlling devices so that they may be readily attached to any graphophone without altering materially the construction of the latter.

In accordance with the invention, several records may be placed in superposed position on the turn table of the graphophone, after which the prime mover therefor may be started. By an independent source of power and a pneumatic control disposed at any desired place the sound box, together with the needle, may be lowered to operative position in engagement with the disc, whereupon the composition thereof will be rendered. When desired, other pneumatically controlled devices may be set in motion to lift the needle from the record and permit the sound box to be returned to a predetermined starting position; the rotation of the turn table stopped; the uppermost record removed from its position on the turn table, thus bringing the record immediately thereunder into operative position; the turn table released to permit its further rotation, and the sound box and needle lowered to engage operatively the uppermost record, after which the operations above outlined are repeated or modified at the will of the operator until the lowermost record has been removed from the turn table.

In the embodiment herein illustrated the several control devices are actuated pneumatically, a switch being provided at any desired place between the source of power and the several independent pneumatic controlling devices, whereby the latter are set in operation at will.

Further improvements will appear as this description proceeds, among which may here be mentioned the means for controlling the volume of sound to regulate the expression, means to insure automatically the return of the sound box to any desired predetermined position with respect to the record and a multiple needle holding device for the sound box.

The invention will be more fully described with reference to the accompanying drawings, in which Fig. 1 is a view in plan of a graphophone embodying the present invention and showing certain of the pneumatic controlling devices, the latter being in the normal position immediately prior to the rotation of the turn table. Fig. 2 is a sectional view taken on the plane indicated by the line

2-2 of Fig. 1 looking in the direction of the arrows. Fig. 3 is a diagrammatic view of the several control devices, showing their connections to the common pneumatic control through the switch, which is located at any desired place and adapted to be manually operated to set in motion any one of the series of pneumatic controls. Fig. 4 is an enlarged detail view in side elevation of a fragment of the sound box, showing the pneumatic control device for raising and lowering the same. Fig. 5 is a view in end elevation of the bellows shown in Fig. 4 and illustrating the automatically actuated valve connected thereto and operable to

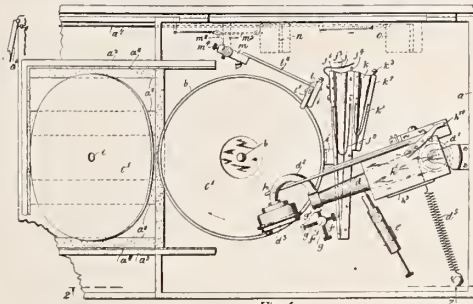

Fig. 1.

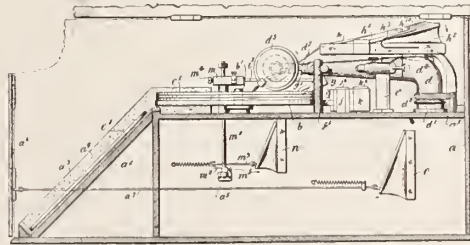
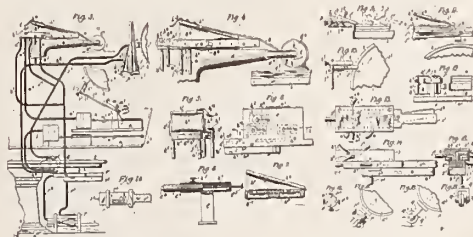

Fig. 2.

place one of the independent control devices under the influence of the master bellows. Fig. 6 is a plan view of the bellows shown in Fig. 4, illustrating in dotted lines the independent connections thereto from the master bellows. Fig. 7 is a view taken on the plane indicated by the line 7-7 of Fig. 6. Fig. 8 is a detail view partially in section of an adjustable stop whereby the return of the sound box to a predetermined starting position is insured. Fig. 9 is a fragmentary view showing the relation of the record changing means to the records. Fig. 10 is a fragmentary view in plan of the devices shown in Fig. 9. Fig. 11 is a fragmentary



view in side elevation of the two bellows controlling respectively the starting and stopping of the turn table, the parts being shown in released position. Fig. 12 is a fragmentary view in end elevation of the devices shown in Fig. 11. Fig. 13 is a view in plan of the controlling switch, which may be located at any desired place and connected through suitable tubing to the master bellows and the several pneumatic controls. Fig. 14 is a view in side elevation thereof. Fig. 15 is a view taken on the plane indicated by the line 15-15 of Fig. 13 and looking in the direction of the arrows. Figs. 16 and 17 are detail views of an improved multiple needle-holder. Figs. 18 and 19 are detail views of a modified form of multiple needle-holder. Fig. 20 is a view in plan of the master bellows illustrated in Fig. 3.

TALKING MACHINE.—Graham W. Brogan, Mount Vernon, N. Y. Patent No. 1,099,913.

In sound producing machines, such as those commonly called "talking machines," "graphophones," and the like, it has been customary to manually apply and remove each sound record or disc for each musical composition, speech, or the like, to be rendered, entailing considerable pauses in the continuity of rendition of the pieces required by the time necessarily consumed in removing and replacing the records.

The object of this invention is to provide means to support one upon another a series of sound records for discs, and to automatically apply, one after another, the records or discs in position for co-operation with the pin of the soundbox, and to automatically cause the required movement of the soundbox to and from the records or discs after the latter have been successively placed in position for rotation, whereby when a series of superposed records have been placed in the machine, and the driving mechanism is started, the musical compositions, speeches or the like, will be rendered from said records one after another, without requiring the machine to be stopped until all of such records have been used.

In carrying out this invention there is provided in a sound producing machine having any suitable means for supporting and rotating sound records or discs and the sound box to coact therewith, means to support a series or plurality of superposed records or discs, means to lower and raise said records and to separate from the series the lowermost record and deposit it upon the record or records that have been used upon the record rotating devices, and means to cause the sound box to be raised and moved away from the records that have been used, and to be moved back over and lowered toward the new record that has been deposited for use, whereby the records may be used successively with the sound box while the machine continues to operate.

Fig. 1 is a side elevation of a talking machine embodying this invention; Fig. 2 is an end view of Fig. 1, looking from the right-hand side, parts being removed, and showing the parts in the playing position; Fig. 3 is a cross-section substantially on the line 3, 3, in Fig. 1; Figs. 4, 5 and 6 are detail views illustrating, in different positions, the dog for separating and depositing one after another

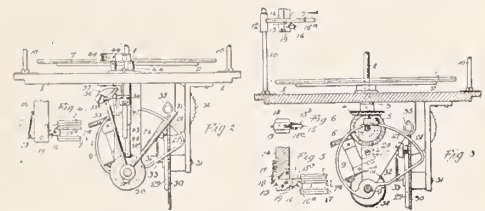

other the superposed records or discs; Fig. 7 is a side elevation illustrating the parts in the positions assumed when the records are lowered to deposit an unused record in position for use, parts being omitted; Fig. 8 is a plan view of Fig. 7; Fig. 9 is

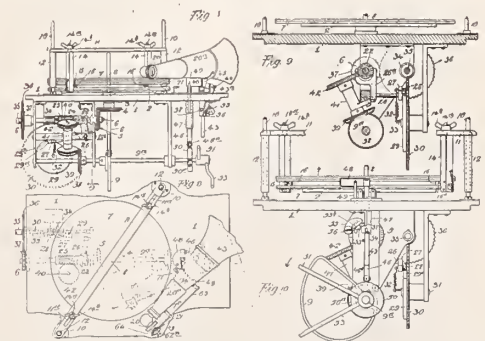

a section substantially on the line 9, 9 in Fig. 7, and Fig. 10 is an end view showing the parts in the position illustrated in Fig. 7, parts being removed; Fig. 11 is an enlarged section on the plane of the line 11, 11 in Fig. 1; Fig. 12 is a similar view on the line 12, 12 in Fig. 1, and Fig. 13 is a detail view of part of the sound pin operating device.

GOOD CHEER CONVEYOR.

The Williams Phonograph Co., of Pueblo, Col., possesses an energetic salesman in J. D. Williams who has operated a "Phonograph Wagon" through the snow-bound farmlands simply to keep the farmers supplied with blue amberols.

TALKING MACHINE JOBBERS WHO ADVERTISE IN THE WORLD ARE LIVE ONES. TRY THEM!

RECORD BULLETINS FOR AUGUST, 1914

COLUMBIA GRAPHOPHONE CO.

SYMPHONY DOUBLE DISC RECORDS.

A5565 Le Prophete (Meyerbeer). "Ah, mon fils" (Oh, my son). Contralto solo in French with orch. Otilie Metzger 12

Samson and Delilah (Saint-Saëns). "Amour viens aider ma faiblesse" (Love lend me thine aid). Contralto solo in French with orch. Otilie Metzger 12

A5570 Il Trovatore (Verdi). "Tempest of the Heart." Baritone solo in English with orch. Louis Kreidler 12

Un Ballo in Maschera (Verdi). "Tis Thou Hast Sullied," Baritone solo in English with orch. Louis Kreidler 12

A5571 Serenata (Tosti). Soprano solo in Italian with orch. Carolina White 12

L'Ultima Canzone (The Last Song) (Tosti). Soprano solo in Italian with orch. Carolina White 12

BLUE-LABEL DOUBLE DISC RECORDS.

Four Dance Instruction Records.

A1540 Columbia Modern Dance Instruction Record—The Maxixe 10

Florence Maxixe 10

A1541 Columbia Modern Dance Instruction Record—The Tango 10

El Farrista—Tango 10

A1542 Columbia Modern Dance Instruction Record—The One-step. 10

Good-bye Broadway—One-step. 10

A1543 Columbia Modern Dance Instruction Record—The Hesitation 10

Columbian Hesitation Waltz. 10

A1546 The Mountains (Gladden). Williams College Glee Club 10

The Royal Purple (Bartlett), and Come, Fill Your Glasses Up (Sousa). Williams College Mandolin Club 10

A5574 Love Has Wings, from "Sari" (Kalman). Soprano and Tenor duet, orch. accomp. Grace Kerns and Chas. W. Harrison 12

Love's Own Sweet Song, from "Sari" (Kalman). Soprano and Tenor duet with orch. accomp. Grace Kerns and Chas. W. Harrison 12

DOUBLE DISC RECORDS.

A1548 Columbia, the Gem of the Ocean (Shaw). With orch. accomp. Columbia Stellar Quartet 10

Medley of American War Songs (Arr by Maurice Smith). Prince's Band 10

A1538 Rain Song (Cook). Sung by the Afro-American Folk-Song Singers. 10

Swing Along (Cook). Song by the Afro-American Folk-song Singers. 10

A1539 Medley of Harry Lauder Songs (Lauder). Prince's Orchestra 10

Moonlight Waltz (Holmes). Prince's Orchestra 10

A1545 Mystic Shrine March (Bond). Prince's Band 10

Marche Turque (Over the Hot Sands) (Ellenberg). Prince's Band 10

A5568 Jesus, Refuge of My Soul (Martyr). Orch. accomp. Columbia Stellar Quartet 12

What a Saviour (Bliss). Baritone solo, orch. accomp. Andrea Sarto 12

TWO PAVLOWA DANCES.

(Recorded Exactly as Danced by this Internationally Famous Dancer.)

A5566 Pavlowa Gavotte (The Glow Worm) (Lincke). Prince's Orchestra 12

Love's Melody (Daniderff). Waltz Hesitation. Prince's Band 12

A5567 Pavlowa (Air de Ballet) (Bendix). Prince's Orchestra 12

Kathlyn (Smith). Waltz-Hesitation. Prince's Band 12

A5572 Joan Waltz-Hesitation (Sawyer). Prince's Band 12

Joan Sawyer's Persian Garden Orchestra 12

Bregeiro (Rio Brazilian Maxixe) (Nazareth). Joan Sawyer's Persian Garden Orchestra 12

Latest Dances Recorded Under Supervision of G. Hepburn Wilson.

A5573 Patriotic Medley (Bernstein). One-step. Prince's Band 12

La Brulante (Winne). One-step. Prince's Band. 12

A5575 "Sympathy" Waltz from "The Firefly" (Frimli). Waltz-Hesitation. Prince's Band 12

Moon Winks (Stevens). Three-step. Prince's Band. 12

A5576 Who Paid the Rent For Mrs. Rip Van Winkle? (Bryan and Fischer). One-step. Prince's Band. 12

The Walla-Walla Man (Bennett). One-step. Prince's Band. 12

Mid-Summer Song Hits.

A1552 When You're All Dressed Up and No Place to Go (Hein). Baritone solo, orch. accomp. William Halley 10

Good-bye, Broadway (Bernstein). Baritone solo, with orch. accomp. Ed. Morton and Peerless Quartet 10

A1551 You can Tango, You Can Trot, Dear, But Be Sure and Hesitate (Von Tilzer). Soprano solo, orch. accomp. Ada Jones 10

Do They Love It? (Abrahams). Baritone solo, orch. accomp. William Halley 10

A1550 Mootching Along (Gilbert and Muir). Baritone and Tenor duet, orch. accomp. Arthur Collins and Byron G. Harlan 10

They Had to Swim Back to Shore (Von Tilzer). Soprano and Tenor duet, orch. accomp. Ada Jones and Billy Watkins 10

A1547 Gone Are the Days ("Z"). Tenor solo, orch. accomp. Charles Harrison 10

I'm Coming Back to Dixie and You (Lyons, Yosco and Mullane). With orch. accomp. Peerless Quartet 10

A1553 My Love Would Fill a Thousand Hearts (Heif). Counter-tenor solo, with orch. accomp. Manuel Romain 10

When You Play in the Game of Love (Feist). Tenor solo, orch. accomp. Geo. W. Ballard 10

A1549 You Planted a Rose in the Garden of Love (Ball). Tenor solo, orch. accomp. Henry Burr 10

Over the Alpine Mountains (Fischer). Tenor duet, with orch. accomp. Albert Campbell (first), Henry Burr (second) 10

VICTOR TALKING MACHINE CO.

No. No. 17592 The Moorish ("Maurice") Glide—One-step (Gus Haenschen). Victor Military Band 10

They're on Their Way to Mexico—One-step (Irving Berlin; arr. by Wm. Schulz). Victor Military Band 10

17595 Valse June—Hesitation (Lionel Baxter). Victor Military Band 10

Love's Hesitation Waltz, from "The Beauty Shop" (Charles Gebest). Victor Military Band 10

35383 Passing of Salome—Waltz Hesitation (Joyce). Victor Military Band 12

Barcarolle—Waltz Hesitation, from "Tales of Hoffman" (Offenbach). Victor Military Band 12

35384 Camp Meeting Band Melody One-step (Gilbert-Muir). Victor Military Band 12

I Love the Ladies Medley One-step. Victor Military Band 12

TWO MORE STANDARD NUMBERS BY "PIETRO"

35367 Rigoletto Quartet (Verdi) (Accordeon). Pietro Diero 12

Light Cavalry Overture (Suppé) (Accordeon). Pietro Diero 12

CATCHY SONG HITS OF THE MONTH.

17590 The Rose of the Mountain Trail (Jack Caddigan-Jas. A. Brennan). Peerless Quartet 10

Alice of Old Vincennes (I Love You) (Keithley-Thompson). Henry Burr 10

17591 When It's Moonlight on the Alamo (Alfred Bryan-Fred Fischer). Peerless Quartet 10

Do You Remember? (Earl Carroll-Music by "Z"). Frederick Wheeler 10

17560 I Love the Ladies (Clarke-Schwartz). Will Halley 10

By the Beautiful Sea (Harold Atteridge-Harry Carroll). Heidelberg Quintet 10

17594 When You Play the Game of Love (Joe Goodwin-Al Piantadosi) Edna Brown-J. F. Harrison 10

Off with the Old Love, On with the New (Ballard Macdonald-Harry Carroll). Albert Campbell-Henry Burr 10

17599 They're On Their Way to Mexico (Irving Berlin) Heidelberg Quintet with Will Oakland 10

Across the Rio Grande (Graff, Jr.-Reed-Ball). Heidelberg Quintet with Will Oakland 10

NEW RECORDS BY THE TOLLEFSEN TRIO AND THE FLORENTINE PLAYERS.

17600 Serenade (Dirgo) (Violin-cello-flute-harp). Florentine Quartet 10

At the Brook (René de Boisdeffre, Op. 52) (Violin-cello-flute-harp). Tollefson Trio 10

35385 Gems from "Follies of 1914" (Buck-Stamper-Hubbart-Hubbell). Victor Light Opera Co. 12

Gems from "Iole" (R. W. Chambers-Wm. F. Peters). Victor Light Opera Co. 12

BLUE LABEL RECORDS.

45056 Old Black Joe (Stephen Foster). Christine Miller 10

Come Out, Mr. Sunshine (Frank Stanton-Paul Bliss). Christine Miller 10

RED SEAL RECORDS FOR AUGUST.

89077 Masked Ball (Ballo in Maschera) ("La rivedrà nell'estasi"—I Shall Behold Her) (Act I) (Verdi) in Italian. With Metropolitan Opera Chorus, G. Setti, director; orch. conducted by G. Scognamiglio. Caruso, Hempel, Rothier, De Seguro 12

88486 Cristoforo Colombo—Aman lassu le stelle (Our Love is Like the Stars). Baritone Solo in Italian. (Franchetti). Tita Ruffo 12

88465 Manella Mia (V. Valente). Tenor Solo. Enrico Caruso 12

88498 Good-Night (Folk Song) (Do Bru Noc, Má Mislá) from "Twenty Bohemian Folk Songs" (Translated and compiled by Rev. Vincent Pisek, D.D.). Soprano and Baritone duet in Bohemian. Emmy Destinn and Dinah Gilly 12

64411 Beautiful Isle of Somewhere. Tenor solo in English. (Mrs. J. B. Pounds-J. S. Fearis). Evan Williams 12

74357 (a) Bourée (J. S. Bach); (b) Menuett (C. W. von Gluck). Violin solos, piano accomp. by George Falkenstein. Maud Powell 12

87198 Rock of Ages (Words by Rev. A. M. Toplady, tune by Dr. Thomas Hastings). Soprano and Contralto duet. Alma Gluck-Louise Homer 10

74346 Good-bye (Tosti). Tenor solo in English. John McCormack 12

NEW EDUCATIONAL RECORDS.

17569 Over the Summer Sea from "Rigoletto" (Verdi) (from "School Song Book"—C. C. Birchard & Co.) Raymond Dixon 10

The Blacksmith (Mozart) (from "School Song Book"—C. C. Birchard & Co.) Reinald Werrenrath 10

17596 1—Blowing Bubbles; 2—Pit-a-Pat; 3—The Sailor. Piano accomp. (from "Songs of Child World, No. 1") (Riley-Gaynor). Elsie Baker 10

1—See-Saw; 2—The Giants; 3—Froggies' Swimming School (Piano accomp.) (from "Songs of Child World, No. 1") (Riley-Gaynor). Elsie Baker 10

17597 Rory O'More (Samuel Lover). Raymond Dixon 10

The Girl I Left Behind Me (Samuel Lover). Raymond Dixon 10

35378 The Bear Story, that Alex Yist Maked Up His Own Se'f (Part I) (James Whitcomb Riley). Harry E. Humphrey 12

The Bear Story (Part II) (James Whitcomb Riley). Harry E. Humphrey 12

EDISON TALKING MACHINE CO.

CONCERT LIST.

28195 Faust—All Hail, Thou Dwelling Lowly! (Gounod) Tenor solo, orch. accomp. Paul Althouse 10

28196 Tannhäuser—The Evening Star (Richard Wagner). Baritone solo, orch. accomp. Thos. Chalmers 10

REGULAR LIST.

2355 Favorite Airs from "Olivette" (Edmond Audran) Orch. accomp. Edison Light Opera Co. 10

2356 A Real Moving Picture from Life (Harry Von Tilzer). Tenor solo, orch. accomp. Walter Van Brunt 12

2357 On the Banks of the Brandywine (Anatol Friedland) Tenor solo, orch. accomp. Eugene Emmet 10

2358 Beauty's Eyes. (F. Paolo Tosti) Baritone solo, orch. accomp. Arthur Blight 10

2359 Will o' the Wisp—Polka (J. S. Cox). Piccolo solo, orch. accomp. Henry Heidelberg and Eugene C. Rose 10

2360 While They were Dancing Around (James V. Monaco). Tenor solo, orch. accomp. Irving Kaufman 10

2361 The Whistling Coquette (Joe Belmont). Whistling and singing, introducing Joe Belmont, orch. accomp. Ada Jones and Billy Murray 10

2362 Sunshine and Rain (Jacques Blumenthal) Contralto solo, orch. accomp. Mildred Howson Hartley 10

2363 Springtime (Erna Troostwyk) Violin solo, piano accomp. Hendrika Troostwyk 10

2364 Do You Remember? Tenor solo, orch. accomp. Irving Gillette 10

2365 Hark! Hark! My Soul (John B. Dykes). Sacred solo, orch. accomp. Edison Mixed Quartet 10

2366 You Broke My Heart, to Pass the Time Away (Joe Goodwin) Tenor solo, orch. accomp. Manuel Romain 10

2367 On the High Alps (Ludwig Andre) Violin, cello, flute and harp. Venetian Instrumental Quartet 10

2368 A Perfect Day (Jacobs-Bond) Mixed voices, orch. accomp. Metropolitan Quartet 10

2369 That Reuben Tango Huskin' Bee (Bert Grant) Rube song, orch. accomp. Byron G. Harlan 10

2370 Looking This Way (J. W. Van De Venter) Soprano and contralto, orch. accomp. Elizabeth Spencer and E. Eleanor Patterson 10

2371 Kathlyn—Waltz Hesitation (Lee Orian Smith) For dancing. National Promenade Band 10

2372 Harmony Bay (Terry Sherman) Tenor duet, orch. accomp. A. H. Campbell and Irving Gillette 10

2373 Happy Tho' Married (Duprez) Monolog. Fred Duprez 10

2374 Amapa Maxixe—Tango Brazilian (J. Storoni) For dancing. National Promenade Band 10

2375 This Is the Life (Irving Berlin). Tenor solo, orch. accomp. Billy Murray and Chorus 10

2376 Three for Jack (W. H. Squire). Baritone solo, orch. accomp. Edwin Swain 10

2377 Down Home Rag—One-step (Wilber C. Sweatman). Banjo, piano and drum. Van Eps Trio 10

2378 Me and Mandy Lee (Kerry Mills) Orch. accomp. Arthur Collins and Byron G. Harlan 10

2379 Who Paid the Rent for Mrs. Rip Van Winkle Medley—Turkey Trot. For dancing. National Promenade Band 10

2380 Stick to Your Mother, Tom. Counter-tenor solo, orch. accomp. Will Oakland and Chorus 10

2381 Ballet Music from "William Tell" (Rossini) Edison Concert Band 10

2382 Whistling Pete. Vaudeville Sketch. Billy Golden and Joe Hughes 10

2383 Baby Mine (A. Johnston). Soprano solo, orch. accomp. Elizabeth Spencer 10

2384 Buck Dance Medley (Kimble). Accordeon, piano accomp. John Kimble 10

PHONOGRAPH CO. OF THE ORANGES.

(Special to The Talking Machine World.)

TRENTON, N. J., June 22.—The Phonograph Co. of the Oranges, with headquarters at East Orange, N. J., filed a certificate of incorporation this week with the Secretary of State. The capital is given as \$10,000, and the incorporators are W. L. Eckert, R. J. Bolan and W. A. Hardy.

THE EDISON AT CLINICS.

Among the many uses which have been devised for the Edison phonograph is one proposed by a prominent London hospital surgeon to record the characteristic changes in the voice—sounds which mark the presence and progress of a variety of diseases. The whoop of the whooping cough and also the hoarse utterances of those suffering from acute or chronic diseases of the throat or lungs were successfully reproduced.

This new application of the phonograph to the purposes of diagnostic and chemical instruction will revolutionize chemical teaching in medical colleges.

WHY MAX LANDAY IS JOYOUS.

Max Landay, the popular Victor distributor, is receiving the congratulations of his many friends in the trade upon the arrival at the Landay domicile on June 5 of Donald Malcolm Landay, weight seven pounds. Mr. Landay, Jr., is already giving indications of rivaling in tonal volume the leading operatic artists in the Victor library.

60 YEARS' EXPERIENCE

PATENTS

TRADE MARKS DESIGNS COPYRIGHTS & C.

Anyone sending a sketch and description may quickly ascertain our opinion free whether an invention is probably patentable. Communications strictly confidential. HANDBOOK on Patents sent free. Oldest agency for securing patents. Patents taken through Munn & Co. receive special notice, without charge, in the

Scientific American.

A handsomely illustrated weekly. Largest circulation of any scientific journal. Terms, \$3 a year; four months, \$1. Sold by all newdealers.

MUNN & Co. 361 Broadway, New York
Branch Office, 625 F St., Washington, D. C.

CHEMISCHE FABRIK E. SAUERLANDT FLURSTEDT bei Apolda i. Th., Germany

The largest manufacturing plant in the world devoted exclusively to the manufacture of Master-Waxes and Master-Blanks for

Gramophone and Phonograph Recording

Sole Manufacturer of Wax "P." the best recording material for Berliner-cut.

Leading Jobbers of Talking Machines in America

Landay
BROS INC.

VICTOR JOBBERS Exclusively
What you want always in stock
400 Fifth Avenue
27 W. 34th Street
563 Fifth Avenue
153 W. 42d Street } New York

1856 WURLITZER 1914

VICTOR
DISTRIBUTERS
VICTORS EXCLUSIVELY

We make a specialty of getting the order out on time—every time.

The Rudolph Wurlitzer Co.
CINCINNATI and CHICAGO

Two points of supply; order from the nearer.

CHASE & WEST DES MOINES IOWA

Machines **Victor** Everything
Records in stock all
Cabinets the time.

WHOLESALE TO IOWA TRADE

Send us your name and address and we will mail you postpaid complete illustrated catalogues, giving detailed information concerning all Victor products. Showing the various styles of Victor Machines, list of all Victor Records, the entire line of Victor Cabinets, Repair Parts and all Accessories. Dealers, let us help you build a Victor business.

PERRY B. WHITSIT L. M. WELLER

PERRY B. WHITSIT CO.,

113 South High Street, Columbus, Ohio.

Edison Phonographs and Records **JOBBERS** Victor Talking Machines and Records

**OLIVER
DITSON
COMPANY**
BOSTON

Largest VICTOR Talking Machine Distributors East of Chicago.

Creators of "The Finest Victor Service." Let us tell you more about our service.

W. J. DYER & BRO.
Saint Paul, Minn.

VICTOR & EDISON
Distributors

Quick Service for all points in the Northwest. Machines, Records, Supplies.



Where Dealers May Secure

COLUMBIA

Product

Ready, Full Stocks, and Prompt Deliveries from Convenient Shipping Centers all over the United States.

Distributors

- Atlanta, Ga., Columbia Graphophone Co., 183 Peachtree St.
- Baltimore, Md., Columbia Graphophone Co., 305-307 North Howard St.
- Birmingham, Ala., Columbia Graphophone Co., 1818 Third Ave.
- Boston, Mass., Columbia Graphophons Co., 174 Tremont St.
- Buffalo, N. Y., Columbia Graphophone Co., 622 Main St.
- Chicago, Ill., Columbia Graphophone Co., 14 N. Michigan Ave.
- Cincinnati, O., Columbia Graphophons Co., 117-119 W. Fourth Ave.
- Cleveland, O., Columbia Graphophone Co., 1375 Euclid Ave.
- Dallas, Tex., Southwestern Talking Machine Co., 1403 Main St.
- Denver, Colo., Columbia Stores Co., 505-507 Sixteenth St.
- Detroit, Mich., Columbia Graphophons Co., 114 Broadway.
- El Paso, Tex., Southwestern Talking Machine Co., Stanton and Texas Sts.
- Hartford, Conn., Columbia Graphophone Co., 719 Main St.
- Indianapolis, Ind., Columbia Graphophone Co., 27 N. Pennsylvania St.
- Kansas City, Mo., Columbia Graphophone Co., 1112 Grand Ave.
- Lincoln, Nebr., The Grafonola Company, 1036 O St.
- Livingston, Mont., Scheuber Drug Co.
- Los Angeles, Cal., Columbia Graphophons Co., 420-422 S. Broadway.
- Louisville, Ky., Columbia Graphophone Co., 425 South Fourth St.
- Milwaukee, Wis., Albert G. Kunde, 518 Grand Ave.
- Minneapolis, Minn., Columbia Graphophone Co., 424 Nicollet Ave.
- New Haven, Conn., Columbia Graphophone Co., 25 Church St.
- New Orleans, La., Columbia Graphophone Co., 933 Canal St.
- New York City, Columbia Graphophone Co., 89 Chambers St.
- Philadelphia, Pa., Pennsylvania Talking Mach. Co., 1109 Chestnut St.
- Pittsburgh, Pa., Columbia Graphophone Co., 810 Bossmer Building.
- Portland, Me., Columbia Graphophons Co., 550 Congress St.
- Portland, Ore., Columbia Graphophone Co., 371 Washington St.; Eilers Music House.
- Providence, R. I., Columbia Graphophone Co., 119 Westminster St.
- Rochester, N. Y., The Grafonola Company, 23 Clinton Ave., South.
- Sacramento, Cal., Kirk, Geary & Co.
- Salt Lake City, Utah, Daynes-Beebe Music Co., 45 Main St.
- San Francisco, Cal., Columbia Graphophone Co., 834 Sutter St.
- Seattle, Wash., Columbia Graphophone Co., 1311 First Ave.; Eilers Music House, 3d and University Sts.
- Spokane, Wash., Columbia Graphophone Co., 818 Sprague Ave.
- Springfield, Mass., Columbia Graphophone Co., 174 Worthington St.
- St. Louis, Mo., Columbia Graphophone Co., 1008 Olive St.
- St. Paul, Minn., Columbia Graphophone Co., 17 East Sixth St.
- Tampa, Fla., Tampa Hardware Co.
- Terre Haute, Ind., 640 Wabash Ave.
- Toledo, O., Columbia Graphophone Co., 229 Superior St.
- Washington, D. C., Columbia Graphophone Co., 1210 G St., N. W.

DEALERS WANTED—Exclusive selling rights given where we are not actively represented.

Write for particulars to the Columbia Graphophone Co., Wholesale Department, Woolworth Building, New York.

Headquarters for Canada:

Columbia Graphophone Co., 363-5-7 Sorauren Ave. Toronto, Ont.

SANGER BROTHERS
Dallas, Texas

VICTOR
Distributors

"We ship the same day."

Southern Victor Dealers

Largest Stock VICTROLAS and RECORDS. Prompt Shipment and Low Freight Rates.

WALTER D. MOSES & CO.
Oldest Music House in Virginia or North Carolina.
RICHMOND, VA.

Edison Phonograph Distributors
for the SOUTHWEST

All Foreign Records in Stock

Houston Phonograph Co., HOUSTON, TEXAS

NEW ENGLAND
JOBBER HEADQUARTERS
EDISON AND VICTOR

Machines, Records and Supplies.

THE EASTERN TALKING MACHINE CO.
177 Tremont Street BOSTON, MASS.

PACIFIC COAST DISTRIBUTORS OF

Victor Talking Machines and RECORDS
STEINWAY PIANOS—LYON & HEALY
"OWN MAKE" BAND INSTRUMENTS

Sherman, Clay & Co. San Francisco Portland
Oakland Los Angeles

The Chicago Edison Jobber

The perfection of Musical Instruments—THE EDISON diamond disc PHONOGRAPH—with EDISON double disc records.

THE PERFECTION OF SERVICE—Our Service.

The Perfection of advertising for the dealer—Our plan.

The Phonograph Company
229 So. Wabash Ave. CHICAGO

Every Jobber in this country should be represented in this department. The cost is slight and the advantage is great. Be sure and have your card in the August List.

VICTOR DEALERS
TRY US FIRST

We carry the Largest Stock of VICTROLAS, RECORDS and CABINETS of any Distributor in the South.

THE CORLEY COMPANY, Richmond, Va.



When you handle the full line of Edison Phonographs you are making for yourself a permanent trade among permanent Edison enthusiasts.

They are the customers who return to you with their friends and with constantly renewed interest in the progress of Edison development.

You do not want to let that sort of customer leave your store unsatisfied because he cannot find the sort of Edison that he wants.

Thomas A Edison

INCORPORATED

59 Lakeside Ave., ORANGE, N. J.



The TALKING MACHINE WORLD

AND
NOVELTY
NEWS

Published Each Month by Edward Lyman Bill at 373 Fourth Avenue, New York, August 15, 1914



Victor-Victrola

A Corner of the Music Room
in the White House



Photo copyright by Waldon Fawcett, Washington, D. C.
Permission for reproduction granted to Victor Talking Machine Co., Camden, N. J.

Leading Jobbers of Talking Machines in America

SERVICE FIRST

EXCLUSIVE VICTOR JOBBERS
WHOLESALE ONLY

Standard Talking Machine Co.
PITTSBURGH, PA.

1856 **WURLITZER** 1914

VICTOR DISTRIBUTERS

VICTORS EXCLUSIVELY

We make a specialty of getting the order out on time—every time.

The Rudolph Wurlitzer Co.
CINCINNATI and CHICAGO

Two points of supply; order from the nearer.

CHASE & WEST

DES MOINES IOWA

Machines **Victor** Everything
Records in stock all
Cabinets the time.

WHOLESALE TO IOWA TRADE

Send us your name and address and we will mail you postpaid complete illustrated catalogues, giving detailed information concerning all Victor products. Showing the various styles of Victor Machines, list of all Victor Records, the entire line of Victor Cabinets, Repair Parts and all Accessories. Dealers, let us help you build a Victor business.

PERRY B. WHITSIT L. M. WELLER

PERRY B. WHITSIT CO.,

213 South High Street, Columbus, Ohio.

Edison Phonographs and Records **JOBBERS** Victor Talking Machines and Records

OLIVER DITSON COMPANY

BOSTON

Largest VICTOR Talking Machine Distributors East of Chicago.

Creators of "The Fastest Victor Service." Let us tell you more about our service.

W. J. DYER & BRO.

Saint Paul, Minn.

VICTOR & EDISON Distributors

Quick Service for all points in the Northwest. Machines, Records, Supplies.

Southern Victor Dealers

Largest Stock VICTROLAS and RECORDS. Prompt Shipment and Low Freight Rates.

WALTER D. MOSES & CO.
Oldest Music House in Virginia or North Carolina.
RICHMOND, VA.



Where Dealers May Secure

COLUMBIA

Product

Ready, Full Stocks, and Prompt Deliveries from Convenient Shipping Centers all over the United States.

Distributors

- Atlanta, Ga., Columbia Graphophone Co., 132 Peachtree St.
- Baltimore, Md., Columbia Graphophone Co., 305-307 North Howard St.
- Birmingham, Ala., Columbia Graphophone Co., 1818 Third Ave.
- Boston, Mass., Columbia Graphophone Co., 174 Tremont St.
- Buffalo, N. Y., Columbia Graphophone Co., 622 Main St.
- Chicago, Ill., Columbia Graphophone Co., 14 N. Michigan Ave.
- Cincinnati, O., Columbia Graphophone Co., 117-119 W. Fourth Ave.
- Cleveland, O., Columbia Graphophone Co., 1375 Euclid Ave.
- Dallas, Tex., Southwestern Talking Machine Co., 1407 Main St.
- Denver, Colo., Columbia Stores Co., 505-507 Sixteenth St.
- Detroit, Mich., Columbia Graphophone Co., 114 Broadway.
- El Paso, Tex., Southwestern Talking Machine Co., Stanton and Texas Sts.
- Hartford, Conn., Columbia Graphophone Co., 719 Main St.
- Indianapolis, Ind., Columbia Graphophone Co., 27 N. Pennsylvania St.
- Kansas City, Mo., Columbia Graphophone Co., 1112 Grand Ave.
- Lincoln, Nebr., The Grafonola Company, 1036 O St.
- Livingston, Mont., Scheuber Drug Co.
- Los Angeles, Cal., Columbia Graphophone Co., 420-422 S. Broadway.
- Louisville, Ky., Columbia Graphophone Co., 425 South Fourth St.
- Milwaukee, Wis., Albert G. Kunde, 516 Grand Ave.
- Minneapolis, Minn., Columbia Graphophone Co., 424 Nicollet Ave.
- New Haven, Conn., Columbia Graphophone Co., 25 Church St.
- New Orleans, La., Columbia Graphophone Co., 933 Canal St.
- New York City, Columbia Graphophone Co., 89 Chambers St.
- Philadelphia, Pa., Pennsylvania Talking Mach. Co., 1309 Chestnut St.
- Pittsburgh, Pa., Columbia Graphophone Co., 810 Bessemer Building.
- Portland, Me., Columbia Graphophone Co., 550 Congress St.
- Portland, Ore., Columbia Graphophone Co., 371 Washington St.; Eilers Music House.
- Providence, R. I., Columbia Graphophone Co., 110 Westminster St.
- Rochester, N. Y., The Grafonola Company, 23 Clinton Ave., South.
- Sacramento, Cal., Kirk, Geary & Co.
- Salt Lake City, Utah, Daynes-Beebe Music Co., 45 Main St.
- San Francisco, Cal., Columbia Graphophone Co., 334 Sutter St.
- Seattle, Wash., Columbia Graphophone Co., 1311 First Ave.; Eilers Music House, 3d and University Sts.
- Spokane, Wash., Columbia Graphophone Co., 818 Sprague Ave.
- Springfield, Mass., Columbia Graphophone Co., 174 Worthington St.
- St. Louis, Mo., Columbia Graphophone Co., 1008 Olive St.
- St. Paul, Minn., Columbia Graphophone Co., 17 East Sixth St.
- Tampa, Fla., Tampa Hardware Co.
- Terre Haute, Ind., 640 Wabash Ave.
- Toledo, O., Columbia Graphophone Co., 229 Superior St.
- Washington, D. C., Columbia Graphophone Co., 1210 G St., N. W.

DEALERS WANTED—Exclusive selling rights given where we are not actively represented.

Write for particulars to the Columbia Graphophone Co., Wholesale Department, Woolworth Building, New York.

Headquarters for Canada:

Columbia Graphophone Co., 363-5-7 Spadina Ave. Toronto, Ont.

Every Jobber in this country should be represented in this department. The cost is slight and the advantage is great. Be sure and have your card in the September List.

Landay BROS INC.

VICTOR JOBBERS Exclusively

What you want always in stock
427 Fifth Avenue
27 W. 34th Street
563 Fifth Avenue
153 W. 42d Street } New York

SANGER BROTHERS

Dallas, Texas

VICTOR Distributors

"We ship the same day."

Edison Phonograph Distributors

for the SOUTHWEST

All Foreign Records in Stock

Houston Phonograph Co., HOUSTON, TEXAS

NEW ENGLAND

JOBBER HEADQUARTERS

EDISON AND VICTOR

Machines, Records and Supplies.

THE EASTERN TALKING MACHINE CO.
177 Tremont Street BOSTON, MASS.

PACIFIC COAST DISTRIBUTORS OF

Victor Talking Machines and RECORDS

STEINWAY PIANOS—LYON & HEALY

"OWN MAKE" BAND INSTRUMENTS

Sherman, Clay & Co. San Francisco Portland
Oakland Los Angeles

The Chicago Edison Jobber

The perfection of Musical Instruments—THE EDISON diamond disc PHONOGRAPH—with EDISON double disc records.

THE PERFECTION OF SERVICE—Our Service.

The Perfection of advertising for the dealer—Our plan.

The Phonograph Company

229 So. Wabash Ave. CHICAGO

The Talking Machine World

Vol. 10. No. 8.

New York, August 15, 1914.

Price Ten Cents

BUSINESS AND THE EUROPEAN WARS.

The Effect on Our Industries Will Temporarily Be Bad—But Disturbed Conditions May Be Followed by Domestic Activity and Merchant Marine Development to Handle Exports.

In discussing the effects of the European wars on business in this country the financial expert of the New York Times on Sunday said the fact that it would have a profound and lasting effect on the principal industries of the country was everywhere conceded. War on a large scale between the nations in Europe which manufacture for the world's markets would curtail, if not destroy for the time being, their export trade. There is only one nation that could take that trade, and that is the United States. This country would export less raw cotton and more cotton goods. The same would be true of other fabrics as well as of manufactures of metal, and, of course, foodstuffs. Means would be discovered or created to attend to the carrying of exports where they were needed. Temporarily, at least, this country would show a tremendous expansion of foreign trade, and the same causes would prevent the importation of many things that in ordinary times come from abroad. American manufacturers would not only monopolize the domestic field, but would go far toward doing the same in many of the foreign ones as well. The only check would be in the things which would be declared to be contraband of war. And, even as to the latter, there would be many venturesome enough to take chances.

All of this would stimulate hugely the productivity of factories and workshops and give employment to labor in vast volume. It would also result in articles of American manufacture being introduced, and put to use in many countries, where the products of foreign origin are now the vogue.

PRESIDENT GEO. E. MICKEL APPOINTS COMMITTEES.

Complete Roster of Official Committees of the National Association of Talking Machine Jobbers Just Announced—Representative Trade Members on Lists.

Geo. E. Mickel, president of the National Association of Talking Machine Jobbers, has just announced his appointments for the various committees for the ensuing year, as follows:

Executive Committee.—O. K. Houck, O. K. Houck Piano Co., Memphis, Tenn.; R. H. Morris, American Talking Machine Co., Brooklyn, N. Y.; C. J. Schmelzer, Schmelzer Arms Co., Kansas City, Mo.; W. O. Crew, Elmira Arms Co., Elmira, N. Y.; P. Werlein, Philip Werlein, Ltd., New Orleans, La., and officers.

Advisory Committee.—J. C. Roush, chairman, Standard Talking Machine Co., Pittsburgh, Pa.; J. F. Bowers, Lyon & Healy, Chicago, Ill.; P. B. Whitsit, Perry B. Whitsit Co., Columbus, O.; J. N. Blackman, Blackman Talking Machine Co., New York City.

Membership Committee.—O. K. Houck, chairman, O. K. Houck Piano Co., Memphis, Tenn.; L. Burchfield, Sanger Bros., Dallas, Tex.; M. Landay, Landay Bros., New York City; F. A. Simon, Rudolph Wurlitzer Co., Chicago, Ill.; F. Nestor, W. F. Frederick Piano Co., Altoona, Pa.

Legislative Committee.—J. F. Bowers, chairman, Lyon & Healy, Chicago, Ill.; C. Droop, E. F. Droop & Sons, Baltimore, Md.; L. H. Clement, Whitney Carrier Co., Toledo, O.; F. W. Corley, the Corley Co., Richmond, Va.; J. C. Roush, Standard Talking Machine Co., Pittsburgh, Pa.

Traffic Committee.—L. C. Wiswell, chairman, Lyon & Healy, Chicago, Ill.; B. L. Crew, Philips & Crew, Atlanta, Ga.; C. A. Mairs, W. J. Dyer & Bro., St. Paul, Minn.; B. J. Pierce, J. W. Jenkins' Sons Music Co., Kansas City, Mo.; H. L. Royer, M. Steinert & Sons Co., Boston, Mass.

Press Committee.—J. C. Roush, chairman, Standard Talking Machine Co., Pittsburgh, Pa.; P. B. Whitsit, Perry B. Whitsit Co., Columbus, O.; T. H. Towell, Eclipse Musical Co., Cleveland, O.; R. Rogers, Robert C. Rogers Co., Washington, D. C.;

The persons in such countries would become accustomed to the American things and familiar with their merits, and would continue the use of them thereafter. In other words, there would be a constant demand created for the American goods that would result in a permanent increase of the export trade. This would show itself with regard to the nations of South America as well as those of the Orient, the Far East and Africa. Ultimately, of course, war of the kind would hurt trade with the countries engaged in it, because of the reduced purchasing power of the peoples caused by the strife and the ruinous taxation that would follow.

CHAS. F. THAYER BECOMES MANAGER

Of the New Columbia Department of the Tel-Electric Co., New York City.

Charles F. Thayer has been appointed manager of the new Columbia department in the warehouses of the Tel-Electric Co., 299 Fifth avenue, New York. This department will probably be ready for formal opening in a week or two, and in the meantime a number of sound-proof demonstration booths are being erected and every possible detail being embodied in the decorations and furnishings to conduce to the comfort and convenience of visitors to the department.

Mr. Thayer is well known in the local trade having been connected with the Columbia Graphophone Co. for the past three years in various sales capacities. His first Columbia connection was under the capable guidance of Hayward Cleveland, the veteran Columbia retail manager. Mr. Thayer also accompanied Frank R. Robertson, the noted travelogue lecturer, on a country-wide tour with the Columbia product, and subsequently joined the sales department of the Columbia educational division.

EFFECTIVE CAMP WINDOW DISPLAY

Made by the Ross P. Curtice Co., of Lincoln, Neb., Wins the Highest Praise—How It Was Prepared Explained for Benefit of the Trade.

(Special to The Talking Machine World.)

LINCOLN, NEB., August 8.—A very attractive camp window display recently made by the Ross P. Curtice Co., Victor jobbers, of this city, made a tremendous sensation, and through the interest it accentuated well repaid those interested in its construction. In telling of its construction C. W. Long, for the Curtice Co., said:

"The 'grass' we made out of excelsior dyed green with green aniline mixed with water; the campfire was made to glow in a very realistic manner by placing a red globe under the red cloth, which was mounted over wire netting to hold it up; the globe we placed in a shade and laid it on



Ross P. Curtice Co.'s Attractive Window.

a mirror so that the light was reflected, and the window had a border of red lights all around it, so that it had an excellent appearance from the outside, and by placing twigs over the fire the leaves and branches diffused the light so that the fire was 'almost' real.

"The accompanying photograph was taken at 2 o'clock in the morning so that there would be no reflection from the street lights, and was made with the aid of 2,250 watt lights, with a twenty-minute exposure. The crowds that were around the window certainly repaid us, and many comments were heard about it, especially the coffee pot, which we beat almost out of shape and blackened with a candle so as to give it a 'used' appearance."

THE ELECTRIC DISC-STOP CO.

The Electric Disc-Stop Co., of Monroe, N. Y., filed a certificate of incorporation this month with the Secretary of State at Albany, N. Y., to manufacture talking-machine accessories. The capital is given as \$6,000 and the incorporators are S. V. Dowling, F. B. Knowlton and D. A. Cashin.

TRAVELING IN WISCONSIN.

William Ide, who was formerly associated with the Phonograph Co., of Milwaukee, Wis., Edison distributor, has been appointed traveling wholesale representative for Thomas A. Edison, Inc., in Wisconsin and upper Michigan, succeeding Wm. P. Hope, who is now Edison jobber at Kansas City, Mo.

A. M. Stewart, Stewart Talking Machine Co., Indianapolis, Ind.

Grievance Committee.—E. F. Taft, chairman, Eastern Talking Machine Co., Boston, Mass.; C. H. Eisenbrandt, E. F. Eisenbrandt & Sons, Baltimore, Md.; H. W. Weymann, W. A. Weymann's Son, Philadelphia, Pa.; F. H. Putnam, Putnam Page Co., Peoria, Ill.; B. N. Neal, Neal, Clark & Neal, Buffalo, N. Y.

Resolution Committee.—R. H. Morris, American Talking Machine Co., Brooklyn, N. Y.; L. Buehn, Louis Buehn, Philadelphia, Pa.; H. A. Winkelman, Oliver Ditson Co., Boston, Mass.; W. N. Dunham, Florida Talking Machine Co., Jacksonville, Fla.; C. N. Andrews, W. D. Andrews, Buffalo, N. Y.

Arrangement Committee.—A. G. McCarthy, chairman, Sherman Clay & Co., San Francisco, Cal.; L. S. Sherman, Sherman Clay & Co., San Francisco, Cal.; C. S. Ruggles, Sherman Clay & Co., Los Angeles, Cal.; A. A. Trostler, Schmelzer Arms Co., Kansas City, Mo.; B. Switzky, Benj. Switzky, New York City.

In sending out this list J. C. Roush, chairman of the press committee, mentions that plans already are being prepared for the 1915 convention to be held at San Francisco. Many special features in connection therewith will be outlined in an early issue of The World. It is expected that a great many members of the association will take in this trip to the convention and the Panama-Pacific Exposition, accompanied by their friends and some of their largest dealers.

The officers of the association elected at the convention in Atlantic City for 1914-1915 are George E. Mickel, president, Nebraska Cycle Co., Omaha, Neb.; Elton F. Taft, vice-president, Eastern Talking Machine Co., Boston, Mass.; Edwin C. Rauth, secretary, Koerber Brenner Music Co., St. Louis, Mo.; William H. Reynolds, treasurer, Reynolds Music House, Mobile, Ala.

PANAMA CANAL WILL HELP PACIFIC COAST MERCHANTS

This Method of Shipping from the East Will Effect a Great Saving in Freight Rates—
San Francisco Pleased at Its Selection for Next Jobbers' Convention—The Phonograph Co.'s New Store to Open This Month—News of the Month Worth Recording.

(Special to The Talking Machine World.)

SAN FRANCISCO, CAL., August 5.—Vacations have about gone the rounds at the various music establishments here, and the forces are in good trim to begin fall campaigns. City schools opened the last week in July, bringing many families home from the country, which naturally acts as a stimulus to business in practically all lines. For this reason most of the business houses arrange their vacations to coincide pretty closely with the school vacations, and the reopening of schools is the signal for resumption of regular duties all round. In the talking machine quarters no time will be lost during the remainder of the year. Business kept up fairly well even when the vacation season was at its height, and all indications point to a good fall. Particular attention is now being called to the new records which were placed on the market while certain patrons were out of town, and the record sections are quite busy. Dealers and distributors of musical instruments generally are looking forward with considerable interest to the opening of the Panama Canal for commerce about the middle of August, as the new method of shipment will mean a great saving to Coast interests receiving goods from the Atlantic seaboard.

Pleased at Selection of San Francisco.

The local trade is elated over the selection of San Francisco as the next meeting place for the annual convention of the National Talking Machine Jobbers' Association. Every effort will be exerted by the trade to make the session a big success, and with the added attractions of the exposition, a large attendance is expected.

Sherman, Clay & Co. were well represented at the national convention last month, L. S. Sherman, Andrew G. McCarthy and Chas. S. Ruggles attending, all having gone East for that purpose exclusively. Naturally they and their houses are especially gratified at the recognition given their city. Mr. Sherman came home directly after the festivities at Atlantic City were over, but Messrs. McCarthy and Ruggles remained over a few days to visit the factory of the Victor Talking Machine Co. Mr. McCarthy, who is treasurer of Sherman, Clay & Co., gives his personal attention to the Victor department of the business, and Mr. Ruggles is manager of the company's Victor distributing branch at Los Angeles. Upon their return to headquarters they pronounced the convention a big success in every particular, and spoke enthusiastically over the hospitality extended to the delegates by the Victor Co. Sherman, Clay &

Co. have just completed the redecoration of their first floors and windows and are celebrating the end of their renovations by a fine display of Victor goods and high class pianos and players.

Peter Bacigalupi, Jr., Retires.

The tendency in the local trade for some time has been toward additions and expansions, but the order of things has been reversed this month by the announcement from Peter Bacigalupi, Jr., that he is retiring from the talking machine business immediately. In fact, he has already vacated the old quarters on the second floor of the Douglas building, 908 Market street, and moved the remainder of his stock to a smaller room in the same building. The name of Bacigalupi has long been identified with the talking machine trade of this city, the business having been conducted under the name of Bacigalupi & Son to date, although the father and son divided their interests about two years ago, Peter, Jr., as he is generally known, taking the talking machines, and Mr. Bacigalupi, Sr., assuming full charge of the electric pianos and Edison dictating machine parts of the business. In the talking machine department a retail and jobbing business in Victor and Edison products was conducted. Peter, Jr., has not announced future plans, but his retirement does not affect his father's business.

Columbia Co. News.

W. S. Gray, district manager of the Columbia Graphophone Co., spent most of the past month away on vacation. He and Mrs. Gray enjoyed a pleasant outing at Lake Tahoe. It was the first real vacation Mr. Gray had taken in about five years and he made the most of it, returning to work with renewed vigor and optimism. F. R. Anglemeier, wholesale manager at the local Columbia warerooms, is spending two weeks in Sonoma County. During his absence C. J. Moore, traveling ambassador for the establishment, is keeping up his end of the work.

The contest for an exposition song, which was announced by the Bulletin a few weeks ago, is now open and full details will be announced shortly. The assurance of the Columbia Graphophone Co., through Pacific Coast Manager W. S. Gray, that the song will be made into a record and will be published by Jos. W. Stern & Co., of New York, has aroused much interest in the contest even at this early date.

Formal Opening of Phonograph Co.

The Phonograph Co., of San Francisco, expects to hold its formal opening in the new Edison

shop on Geary street early in August. The remodeling of the premises is rapidly nearing completion and some of the stock is being moved from the old location on Post street, where the business was conducted under the name of Babson Bros. The new place has been fitted up in first class shape and increased business is anticipated by Manager J. S. Baley in the new location. He reports a good July business in spite of the attention given to preparations for moving, and with the improved facilities and more desirable location he considers prospects bright for fall trade.

Morgan Resigns.

J. J. Morgan has resigned his position with the Emporium as manager of the talking machine department. General Manager A. A. Schell, of the Emporium music sections, says each month so far this year has shown an increase over the corresponding period of last year in the talking machine section, where Columbia goods are handled exclusively.

Pacific Phonograph Co. Plans.

R. A. Pommer, head of the Pacific Phonograph Co., has resumed his duties incumbent upon his business after a vacation at Lake Tahoe. J. E. McCracken, traveler for the company, spent several weeks in southern California and secured several new accounts in that section. He returned to San Francisco a few days ago, and is now establishing his bride in a home here, having been married just before leaving for the South. Arrangements have been made with Edw. Borgum to represent the Pacific Co. in the southern part of the State, with headquarters in Los Angeles. He was formerly with the Southern California Music Co., of that city. Mr. Pommer reports a better business for July than for June.

Manager J. J. Black, of the Wiley B. Allen talking machine department, says the demand for dance records continues a potent factor in the business, and the new style No. XI. Victor Victrola is the favored machine.

FAVORITE WITH SCHOOL CHILDREN.

(Special to The Talking Machine World.)

STUBENVILLE, O., August 3.—At a recent outing given the pupils of the Washington School of this city, a Columbia "Favorite" machine played a prominent part in the day's festivities. The school owns this machine and a goodly number of records, which were purchased from the National Talking Machine Co. after the energetic sales efforts of Lambert Friedl, the company's manager. The school-children danced to the music of the "Favorite" and evidently thoroughly enjoyed and appreciated the various records.

Opportunity has knocked at many a man's door when he was down at the corner saying, "Here's good luck."

The Success of Your Talking Machine Department

Is to a *large* extent dependent upon the service your distributor gives you.
This admitted makes it important that you secure the best service obtainable.

AND THAT IS EASTERN SERVICE

To use it is to swear *By* it not *At* it.
May we not have the opportunity to convince you that our service is exceptional?

EASTERN TALKING MACHINE COMPANY

177 TREMONT STREET, BOSTON, MASS.

EDISON

FOR NINETEEN YEARS TALKING MACHINES EXCLUSIVELY

VICTOR

OUR DISC RECORD ALBUMS

ARE THE BEST FOR VICTOR, COLUMBIA
AND ALL OTHER TALKING MACHINES

THE ONLY CONVENIENT AND SAFE WAY TO PROTECT DISC RECORDS

These Record Albums will Pay for Themselves in a Short Time by Preserving Records. When Full the Albums are Flat and Even Like Books. They will Fit in a Library Cabinet or Book Case, or They will Lie Flat on One Another.

For Durability, Artistic Design and Finish, our Albums have no equal. They are made in the most substantial manner by skilled workman, and are first-class in every particular. We sell them at very low prices to meet competition.

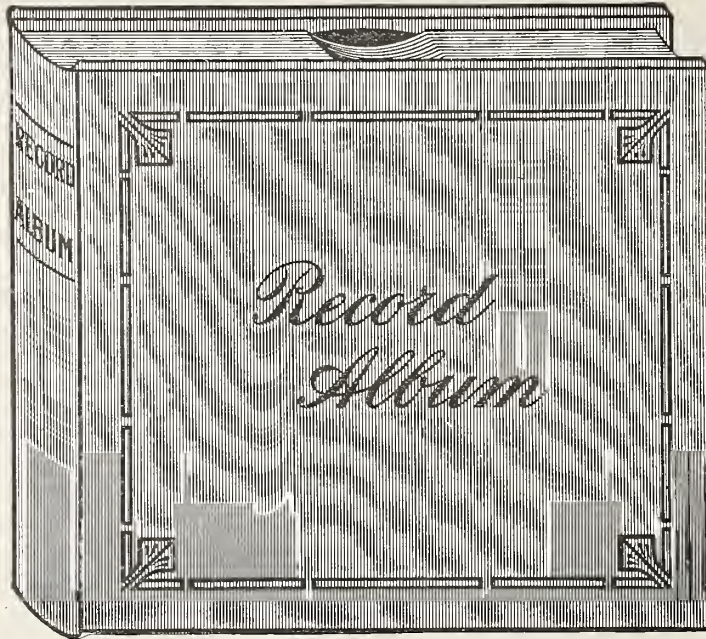

TO DEALERS:

In reply to the many requests we are now receiving for

RECORD ALBUMS containing 10 pockets, we have to say we make Albums, containing any number of pockets that are wanted and to fit all styles of Cabinets.

Write for sample and prices of our Albums, which are superior to all others
Address **NATIONAL PUBLISHING CO., 235 South American St., Philadelphia, Pa.**

KIPP-LINK CO.'S STREET PARADE

Makes Indianapolis "Sit Up and Take Notice" When Twenty-two Drays of Edison Phonographs Paraded the Streets Recently—Only a Partial Shipment—Columbia Business for July 50 Per Cent. Better Than Last Year.

(Special to The Talking Machine World.)

INDIANAPOLIS, IND., August 9.—Indianapolis literally "sat up and took notice" a few days ago when the Kipp-Link Phonograph Co., 345 Massachusetts avenue, jobbers for the Edison disc phonographs, put on a parade in the streets of Indianapolis the equal of which probably was never seen before in this city.

Passers-by on the downtown streets, seeing a dray loaded down with boxes, glanced at it for a moment and then looked in another direction. Then they happened to look again and they paused and wondered. There was not one dray, but twenty-two drays, all loaded to the "brim."

The drays were appropriately decorated with placards announcing that in the boxes on the twenty-two drays were boxes containing the first partial shipment of Edison disc phonographs to the Kipp-Link Phonograph Co. The procession w nearly two blocks long and it passed through all of the downtown streets and finally proceeded to the Kipp-Link warehouse. The entire shipment, valued at \$50,000 by Walter E. Kipp, president and general manager of the Kipp-Link Co., was brought from the freight house to the warehouse in the remarkably short time of five hours.

Enthusiasm was rampant in the vicinity of the Kipp-Link house for a few hours after the shipment had arrived. Persons who had seen the parade came in to inquire about the Edison goods.

Mr. Kipp said the shipment just received represents approximately one-fourth of the goods which have been ordered for the fall trade by the Kipp-Link Co.

"We have been working every night for the last two weeks preparing for fall business," said Mr.

Kipp. "While business is not flourishing in this hot weather, the indications are that we will have an extraordinarily large business this fall. Reports from our dealers in this part of the country point to that end. There is every reason to count on good business this fall, and we are preparing to meet all demands."

Business conditions in the talking machine line have not been flourishing, but still business has been fairly good. A. W. Roos, manager of the local Columbia Graphophone Co.'s store, says an examination of his records shows that business in July was 50 per cent. better this year than it was a year ago in the same month. Mr. Roos is also counting on rushing business early this fall. He says the indications are that business in his line will be especially good.

The Stewart Talking Machine Co., jobbers for the Victor machines, reports good business conditions and is preparing for a large fall trade.

The Carlin Music Co., 23 North Pennsylvania street, has put in a line of Crescent talking machines. It is claimed that all disc talking machine records can be played by this machine.

THE SALESMAN OR THE CONCERN.

How the Personal Friendship of the Dealer and Salesman Can Be Utilized as an Advertising Asset for Their Establishments.

Salesmen as a rule are not life fixtures with a manufacturer. They are very apt to be here to-day and with some competitor to-morrow. For this reason many concerns hesitate to help the salesman build personal good will by the use of personal letters, which might make it easier for him to carry a string of customers with him when he leaves. For the same reason it is also the practice of some to circularize their dealers with this object in view, emphasizing the fact that the service and co-operation they are receiving comes from the company and not the salesman. Yet it is obvious that the personal friendship of dealer and

salesman is an advertising asset too great to overlook.

Commenting on this idea, Printers' Ink proceeds to tell about one method of constructing a letter so as to cash in on a salesman's personal acquaintanceship, and yet making it strictly a company appeal, illustrated in the following letter used by the Parry Manufacturing Co., Indianapolis, Ind.:

"Mr. Brown, who calls on the Massachusetts trade, feels that in pursuing your sales activities you cannot afford to overlook features that have made our line the hardest hitting and most liberal money making proposition now before the local dealer. He suggests the following reasons why:

"Our * * * line is the very line you are going to need. It meets your wants, maintains your custom and makes you money. It is a lie that stands out pre-eminently in Massachusetts to-day because of its peculiar adaptability to the specific trade conditions, and Mr. Brown is convinced that you are the logical dealer in Blank to handle it."

Here one has a good example of getting the personal element into the letter without submerging the company. The value of the introduction of the salesman's name is the more apparent if considered with the name omitted. This little personal touch makes all the difference in the world—it takes the letter out of the circular class and puts it into the letter class.

NARROW ESCAPE FROM FIRE.

The lumber yards of the Victor Talking Machine Co., Camden, N. J., had a narrow escape from fire at the foot of Market street recently, causing damage to the amount of \$10,000. The firemen battled for nearly four hours with the flames before they were subdued.

PROGRESSIVE JOBBERS ADVERTISING IN THE TALKING MACHINE WORLD. CONSULT THEIR ANNOUNCEMENTS.

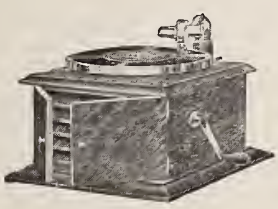

Victrola IV, \$15
Oak



Victrola VI, \$25
Oak

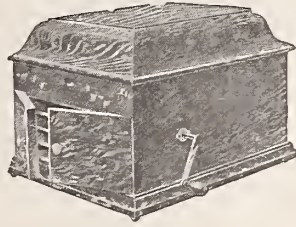

Victrola VIII, \$40
Oak

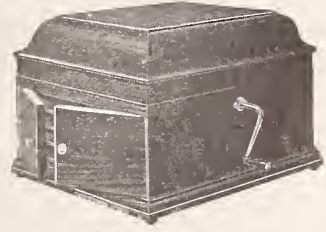

Victrola IX, \$50
Mahogany or oak

To the public, "Victrola" means the world's best music.

To the music dealer it means all that—and more. It is the very foundation of music trade success.



Victor Talking Machine Co.

Camden, N. J., U. S. A.

Berliner Gramophone Co., Montreal, Canadian Distributors.

Always use Victor Machines with Victor Records and Victor Needles—the combination. There is no other way to get the unequalled Victor tone.



Victrola X, \$75
Mahogany or oak

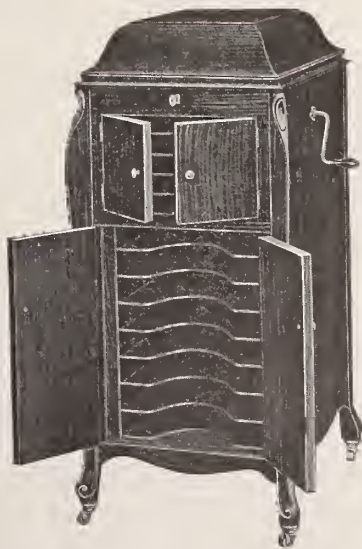

Victrola XI, \$100
Mahogany or oak

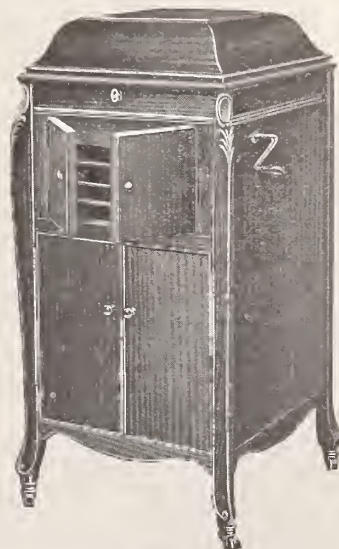

Victrola XIV, \$150
Mahogany or oak



Victrola XVI, \$200
Mahogany or oak

FEATURING NATIONALLY ADVERTISED GOODS

Notable Exhibition Made by J. L. Hudson Co. of Detroit—Victor Display of Significance and Attracts Great Attention—Columbia Graphophone Co. and Other Concerns Look for Immense Trade This Fall—European War Will Not Hurt as Much as Expected.

(Special to The Talking Machine World.)

DETROIT, MICH., August 9.—Victor talking machines formed a part of a noteworthy exhibition in Detroit during the last two weeks of July—a manufacturers' exposition of nationally advertised goods held by the J. L. Hudson Co. The object was to make the citizens of Detroit familiar with the mercantile establishment at which could be obtained the lines of goods which are advertised throughout the country by means of the magazines and other publications of country-wide circulation and prestige. Only manufacturers who do national advertising were invited to participate and, space being comparatively limited, though the store is a

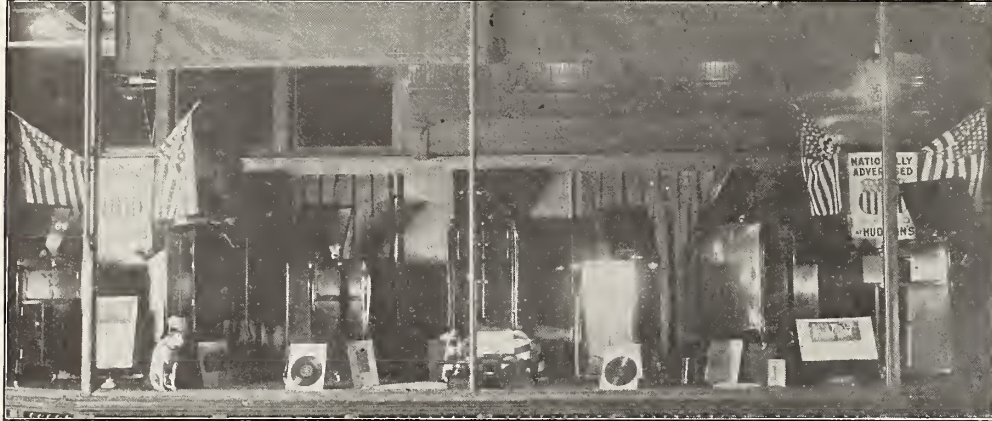

Display of Victors in the J. L. Hudson Co. Window.

very large one, not more than one line of any kind of goods could be accommodated. As a line must be drawn somewhere, it was decided to limit the number of manufacturers participating to 100, this including all kinds of articles from pianos to tooth powders.

The most important articles were exhibited both in the salesrooms and in the show windows. The accompanying photograph shows the Victor exhibit in one of the windows.

The exposition was a large success and will be repeated next year, though it will not be held until September. In September the natural autumn quickening of trade will bring many more people to the store than in July, and there will be more national advertising to be interested in. Talking machines are so widely and consistently advertised that the exposition was of particular benefit to this line of merchandise.

Inquiry from talking machine dealers of both

city and State indicates that the coming fall and winter season will be by far the best the trade ever has known. The branch house of the Columbia Graphophone Co. has several new accounts lined up in Detroit to be opened in September, and inquiries from the smaller cities of the State have been so encouraging that S. E. Lind, assistant manager, will make a personal trip through lower Michigan within a few weeks to take up the good business that has been offered.

Advices received from present representatives of the company indicate that many of them will use a great many more machines this year than they formerly have. It is in the small towns that the

effects of the big crops will be felt first. The farmers already are beginning to spend their money, though they will not be over-active in this way until they get a rest from harvesting. Life with them, in the late summer, is "just one darn crop after another."

Grinnell Bros., Victor jobbers, are having similar experiences. Dealers from a wide range of territory are planning to lay in big stocks for the fall trade. Unsolicited orders and inquiries have come from several States some distance away, and in greater numbers from Ohio, Indiana and Michigan, which Grinnell Bros. cover quite thoroughly.

"We haven't been able to accumulate any large stock, though we have tried," said Harry Rupp, manager of the talking machine department of Grinnell's. "We are constantly short of the \$25, \$75 and \$150 styles. We do not get any too many of the other styles. They seem to go out as fast as they come in. The indications are that in spite

of the greatly increased production of the factories, there is likely to be a shortage again next December, because of the greatly increased demand. If we are just playing even now, what may we expect when the real activity comes?"

Detroit dealers are not much perturbed by the war in Europe. It is likely to abstract from 10,000 to 20,000 men from Detroit's citizenship, but the bulk of the foreigners called away are not of the buying kind. Their departure may cause a shortage of labor in the city, but it will give more work to Americans, at better pay, and the Americans will spend more money, and spend it right at home, whereas the foreigners, most of them, spend but little and send the bulk of their earnings to Europe.

They are not valuable citizens for that reason. They live as cheaply as they can, thousands of them in absolute squalor, recent investigations have developed. In the way of business they produce nothing, because they consume hardly anything except food. Even their food is of the cheapest kind. The money they earn, therefore, does not help make business for anybody. Detroit business men will not be a bit sorry to see a big decrease in population if that is the class to leave.

Max Strasburg, of the Max Strasburg Co., has returned from an automobile tour of several thousand miles through the East. He took in the talking machine jobbers' convention at Atlantic City for a while, meeting old friends, then went on to Philadelphia and Washington. Mr. Strasburg is the most optimistic of all the talking machine dealers in Detroit. He never has known really dull times since he established his store three years ago. The visitor does not need to be informed of this, for always there is at least one customer in the store, and generally several; sometimes a crowd.

TRADE IN AUSTRIA-HUNGARY.

In a commercial review of Austria-Hungary, published in the July 28 issue of the Daily Consular and Trade Reports, Consul General Charles Denby, stationed at Vienna, Austria, refers to the piano situation in that empire as follows:

"The piano trade is almost German, the American imports being noticeable only in pianos (small upright pianos) and reed organs, and in the trade in these goods no great figure was reached."

The official figures in this article show that Austria-Hungary exported to the United States musical instruments to the value of \$173,457 in 1912 as compared with \$200,244 in 1913. It is also stated that Austria-Hungary imported phonographs valued at \$1,000,000 direct from Germany in 1912, while from the United States the importation of phonographs valued only \$3,600. The consul general remarks, however, that a large proportion of the imports of phonographs from Germany are undoubtedly American goods.

The DITSON Pledge

is to see that our clientele has a better service than ever—setting a new standard in Victor jobbing deliveries. The demands of alert Victor dealers—the kind that grow—are many and varied, and we furnish the "first-aid" in every instance.

We believe this year's Victor business will be of tremendous proportions, and it will pay you to have

The Fastest Victor Service

which is a requisite in this hustling age. We possess the largest stocks, the best organization and most up-to-date equipment in the Eastern half of the country.

This covers Victor machines, records and supplies of every kind.

Will you let us tell you more about Ditson co-operation? A postal gets this information!

OLIVER DITSON CO., Boston, Mass.



With every German and Russian and Austrian and Servian and Belgian and Frenchman in this country breathing battle and oozing patriotism, the completeness of the Columbia foreign record catalogues, is a boon to every dealer who can reach a foreign colony.



(Write for "Music Money," a book "full of meat" for those dealers interested in quick and frequent turnover of capital.)

Columbia Graphophone Company
Woolworth Building, New York

CINCINNATI TRADE RATHER QUIET

For the Past Month Owing to the Absence of People at Summer Homes—Outlook for Fall Is Exceptionally Good and This Is the Report of Leading Houses—News of the Month.

(Special to The Talking Machine World.)

CINCINNATI, O., August 9.—Generally speaking, business was quiet in the talking machine field during July. This was due to the average dullness and the absence from the city of the best record buyers. Business was practically confined to records, the volume of sales for the month being fairly good. This might be said to be due to the manner in which the attaches of the various houses are keeping in touch with their clients.

The Sheriff's office next Saturday morning will offer at auction, under foreclosure proceedings, the home of John Arnold, former Elm street dealer, who left the city earlier in the year. The disposal of his home in Hyde Park will mark his actual passing away from the local field. Mr. Arnold is now supposed to be in Denver.

Manager Dittrich, of the Rudolph Wurlitzer Co., in discussing business for the past month, said:

"The month of July, in spite of the general business conditions, showed a very satisfactory increase over last year. The last two weeks were especially good, and at the present time we are enjoying a big demand for Victor goods, both wholesale and retail. As usual, our fall shipments were ordered well in advance. We are now storing Victrolas so as to be better able to meet the demand when the rush for orders will begin and when the stock will not be so plentiful.

"From reports reaching us through our representatives, and also from correspondence and orders from our wholesale trade, we gather that conditions are exceptionally good. The talking machine dealer is surely in a position 'all by himself,' as he is enjoying a most active trade at the time of year when the product would be considered as out of season, and the best period of the year will shortly be reached without any intermediate dull period. The new styles, No. 10 and No. 11, have made a most favorable impression, and these two popular styles will undoubtedly enjoy even greater popularity than heretofore. The fumed oaks, No. 9 and No. 10, have taken this part of the country by storm, and our estimate, although we made it very large, was not miscalculated. We have already booked a number of orders for fall delivery, and every day

is adding to the number. The good prospects are especially appreciated at this time because of the probability of a plentiful supply.

"In our retail department we never before were holding so many orders for fall delivery, and our files never held so many prospective purchasers at this time of the year. The fall business will undoubtedly be a record-breaker."

When approached on business conditions, Manager Whelen of the local Columbia store, said: "Despite the fact, the inevitable fact, that business is bad, I must say that we have held our own and made a slight increase over the same period of last year. The 'dance craze' has to a certain extent held up the retail end, and dealers throughout the territory do not appear to be discouraged in any way, in fact, talk very optimistic of the summer business so far and are very enthusiastic about the fall prospects."

No one has been engaged as yet to take charge of the Victrola department of the Cable Company, which will be in operation before the end of this month. Mr. Summey hoped to have this department ready by last Saturday. His goods have reached the city, but there has been a delay in putting up the booths as well as getting the right kind of a man for handling the work.

The record wants was the feature of the Lyric Co.'s business during July, according to Manager Ahaus.

RETURNS TO ITS OLD HOME.

The New York Talking Machine Co. Again at 81 Chambers Street—Many Improvements Installed—Great Achievement in Handling Business While in Temporary Quarters.

The New York Talking Machine Co., Victor distributor, which had been occupying temporary quarters at 77 Reade street, New York, since its disastrous fire on June 21, moved back this week to its building at 81 Chambers street. Workmen are still engaged in removing all traces of the conflagration at this latter address, although the progress that has been made in the past five weeks is really remarkable.

In order to give its patrons every possible convenience, the New York Talking Machine Co. took advantage of the incidental renovating and remodeling to make several changes in the equipment of their warerooms which should prove of value to visiting dealers. One of these improvements is the construction of additional demonstration booths for the use of the company's dealers. These booths are being built along somewhat novel lines, and when completed will be as soundproof as human ingenuity can make them. The new booths will give the warerooms an equipment of ten rooms, all furnished and arranged in a dignified, tasteful fashion.

The basement and sub-basement at 81 Chambers street, which were practically destroyed by the fire, have practically regained their normal appearance, and Sales Manager Moody, assisted by a corps of assistants, is busily engaged in refilling the thousands of stock bins. According to present plans, the company will retain its auxiliary stock rooms in several buildings nearby, as it has in the past.

When it is considered that the New York Talking Machine Co. did not cease its shipments for a single day after the fire destroyed its stock of 170,000 records and 1,500 machines, some idea of the efficiency and calibre of its sales organization may be gleaned.

The fire, as a matter of fact, had not been halted in its ruinous course when Vice-President Geissler secured temporary quarters for the executive and sales departments. Since June 22 the company's business has been conducted at these quarters with thoroughness and dispatch, and Manager Williams and Sales Manager Moody have worked indefatigably to give the dealers every possible co-operation in the face of terrific handicaps.

Habit is a master of man's own making, but one he serves with unconscious zeal. An organized or trained mind is the best of masters. It cannot be defined. It is progressive and expanding. A complete description to-day would not apply to the mind of to-morrow.

PERFECT IN EVERY DETAIL



ARTISTIC
BUILT LIKE A WATCH
COMPACT, POWERFUL

Thousands of satisfied users bespeak its excellence.

Send 50 cents stamps for sample. Write on your business letter-head only. Place regular order through your jobber.

STANDARD GRAMAPHONE
APPLIANCE COMPANY
173 Lafayette St., New York

NAME PLATES
DECALCOMANIE

Why not apply a transfer nameplate on your talking machine cabinets?

WRITE FOR SAMPLES AND PRICES. SKETCHES FREE

GEO. A. SMITH & CO., INC.
74 CORTLANDT ST., N. Y.

EDISON
Winnipeg Piano Co.
Koch & Drow
Brooklyn Piano Co.

RECORD LIBRARY OVERFLOWS

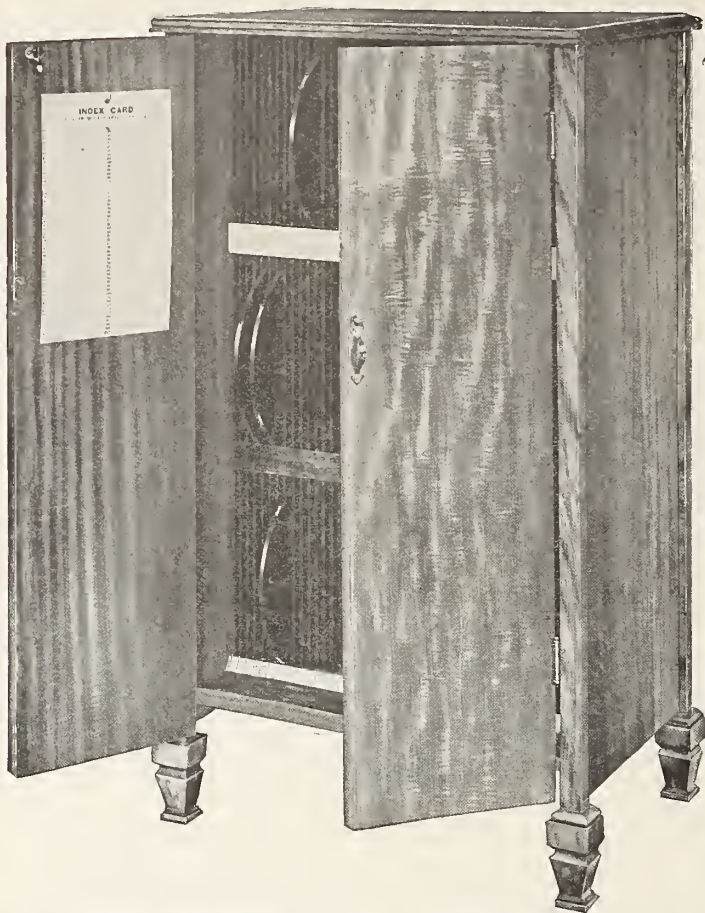

SALTER FELT-LINED CABINET No. 20

ARE CAUSING A BIG DEMAND FOR ADDITIONAL FILING FACILITIES

Such calls can best be met with the Salter (Style 20) Cabinet.

This Cabinet was designed to be used in conjunction with the EDISON disc phonographs, but it made such a tremendous hit that we were obliged almost immediately to construct it also for COLUMBIA and VICTOR records, of which it holds 159. It holds 132 EDISON records. Our catalog shows it in detail.

THIS CABINET OFFERS SOME BIG SALES- MAKING OPPORTUNITIES. JUST FIGURE OUT ITS POSSIBILITIES IN YOUR OWN CASE

N. B.—Orders for your Fall cabinet stock will receive the most complete attention if sent in now. Don't delay.

SALTER'S FELT-LINED CABINETS ARE STANDARD IN THE INDUSTRY

Salter Mfg. Co.

337-43 N. Oakley Blvd.

CHICAGO

PHILADELPHIA TRADE PLANS FOR IMMENSE BUSINESS.

War Troubles Abroad Do Not Daunt Quaker City Trade, Which Is Enlarging and Making More Attractive Its Talking Machine Quarters Preparing for an Immense Fall Business—New Office Building for the Victor Co. Now Under Way—News of the Month.

(Special to The Talking Machine World.)

PHILADELPHIA, PA., August 8.—The talking machine business in Philadelphia has been very much better in the month of July than it was in 1913, and as every month of this year thus far has shown a good substantial increase it is easy to be seen how well satisfied the dealers should be, and they apparently are. At houses where the piano business has been running slightly behind last year they have been forging ahead on talking machines and the outlook is most promising for a continuation of the same conditions during the remainder of the year.

Several of the firms are making extensive improvements in their stores, getting them in shape for the fall and winter business. The Talking Machine Co. has taken the second floor of the building at 143 South Broad street and is having a wide stairway installed from the first floor to the second. This will practically double its space. It will have two private hearing rooms on the first floor and the appearance of the place will be very much improved. A fourth store will shortly be opened at Forty-second street and Lancaster avenue. This will give the firm four locations that are wide apart and yet in densely populated sections.

H. A. Weymann & Sons are having the entire first floor of the store repapered and repainted. This includes the talking machine department. It will be bright and attractive when finished. They have been doing a splendid business all through July, especially in their wholesale department, where the circulars they have sent out urging the trade to order early have had the effect desired, and to-day they have more than double the amount of advance business over last year. Of the Weymann sales force the following have been away on vacations: Malcolm Fox, J. W. Walsh and Mau-

rice Luckenbach. Mr. and Mrs. William A. Weymann and their daughter, Miss Helen Weymann, are summering at Wildwood.

C. J. Heppe & Sons have added at least a third more record racks to their already extensive department in the wholesale section. Manager Ellwell notes that the business is much better than last year and he is of the opinion that the trade will enjoy an excellent fall and winter business.

The Pennsylvania Talking Machine Co., the headquarters for the Columbia in Philadelphia, is having the interior of its store entirely redecorated and is otherwise making the place more attractive than ever before. Its business all summer has been showing wonderful gains and if the present ratio is kept up it will not surprise the management if they gain nearly 100 per cent. over last year. Joseph Patrick Murphy, for a long time head floor man at the Pennsylvania company, was married on June 10. The announcement came somewhat suddenly, for the rumor that Joe was to be married had been in the air off and on for the past two years. He has taken his bride to a dove cote in Germantown. Walter L. Eckhart, manager of the Pennsylvania company, will spend several weeks at Atlantic City this month. Business interests in that city have brought about this decision to spend his holidays at Philadelphia's popular resort.

G. F. Wuertle, of the Gimbel Bros. talking machine department, is responsible for the statement that they have run way ahead every month of the current year. Mr. Wuertle will take his vacation the second and third week in August. A. Carabine has just returned from his vacation, which was spent in New York State and at and near his old home in Meriden, Conn.

John Wanamaker has completed the improvements in his talking machine department, and I

doubt whether there is a finer department in the United States. Additional hearing space is represented in twelve rooms, which are built about the large concert hall in which will be given, during the fall and winter, the most remarkable series of recitals ever heard in this city. The Victor will be exploited, and artists will play with the machine showing its great breadth as an entertainer.

The trade here is generally pleased with the prospects of the Victor Co. adopting the proposed clause in its contract that interest be charged on deferred payments. This, they all feel, is the only sure way of securing the relief so much desired, for a Victor suggestion is always carried out to the letter.

The Edison dealers, Messrs. Burkhart & Blake, who have fine warerooms at Eleventh and Walnut streets, contemplate the addition of an extra hearing room shortly. They have enjoyed a very good business all summer and have been doggedly keeping at it and their success has been far beyond their expectations. They believe the public is going to recognize the marvelous clarity of tone of the Edison this fall and that that instrument is going to forge right ahead.

The great office building which is being erected for the Victor Talking Machine Co. is now well under way, and when completed will cost \$500,000. Activity continues unimpaired at the Victor works, although there is much talk of some of the employes who were born in Europe going off to fight for their Fatherlands. This is rather doubtful now in view of the fact that the consuls of the various countries claim they cannot transport the men abroad. This, of course, will keep those who had proposed fighting for their country at their work.

Among the incorporations filed with the Secretary of State at Delaware this week was that of the Symphony Instrument Co., with the object of manufacturing phonographs and other musical instruments; capital \$250,000. The incorporators are: F. R. Hansell, Philadelphia, Pa., G. H. B. Martin and D. T. Vennel, Camden, N. J.

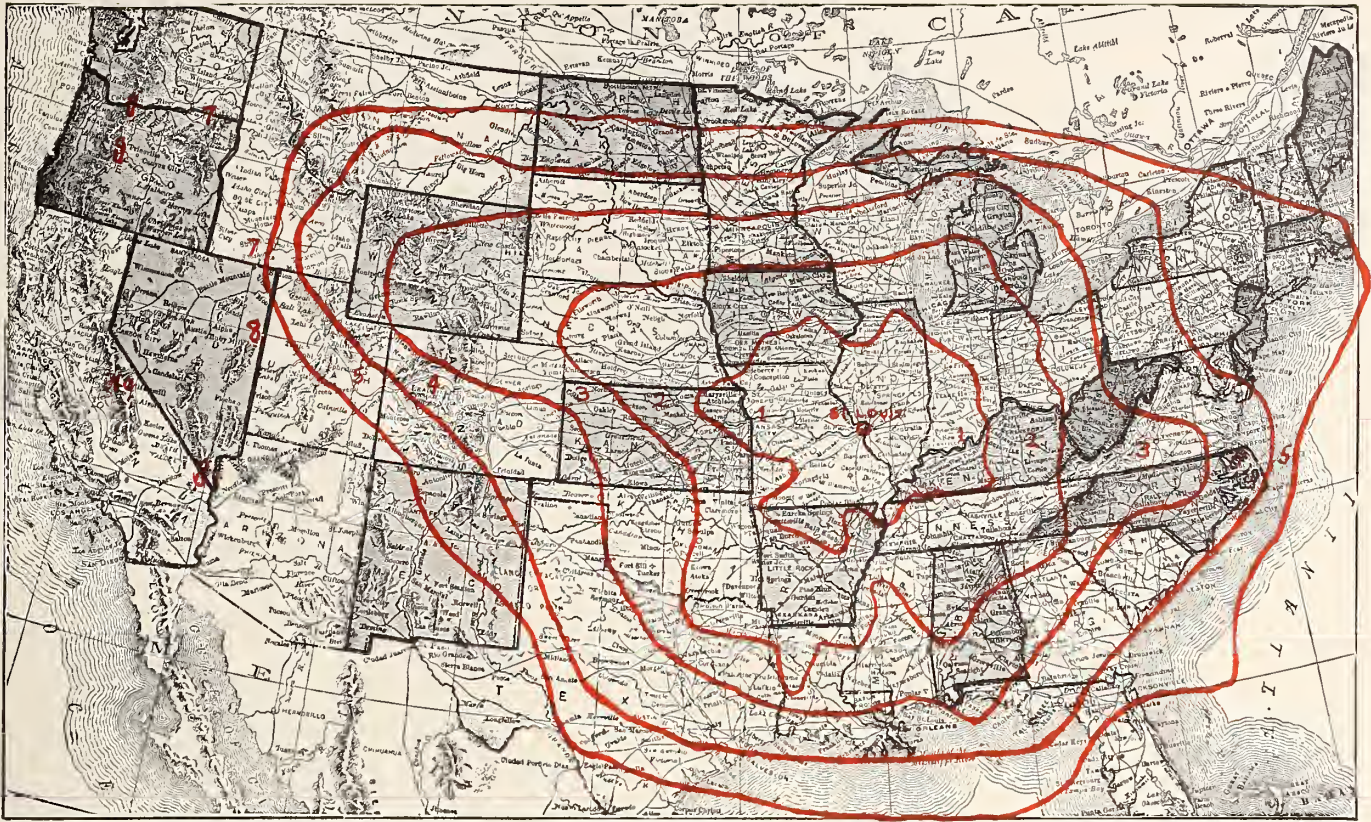

Saint Louis is at your door!

THIS map shows just how long it takes a freight shipment to reach you from our **COMPLETE Victor Stock** in Saint Louis.

Every day in the year over twelve hundred "Package" cars leave Saint Louis with small freight shipments—and these cars arrive at their break-bulk destinations **ON SCHEDULE!**

Each circle on the map represents one day from Saint Louis by "Package" car.

Express and parcel post shipments from Saint Louis travel faster, of course. But the map shows that Saint Louis is at your door even on a freight basis.

And so you see, our COMPLETE Victor Stock is at your door!

Koerber-Brenner Company



Victor Distributors

Saint Louis



Harry G. Koerber
President & Treasurer

Edwin C. Rauth
Vice-President & Secretary

The BIG Victor Stock is in Saint Louis!

HERE, at the very center of the country is a Victor stock so big that we easily fill a large part of the orders other jobbers are short on.

So high a percentage of such orders are filled by us that we now SOLICIT the "short" orders your regular jobber can't fill.

We couldn't solicit such business if we were not prepared to take care of it! But we ARE prepared. We have the one BIG Victor Stock—Records, Machines and Accessories—and if anybody in America has what you want and can't get from your regular jobber, we are that house.

Send US your "Short" orders.

Buy your Victor goods from whomsoever you will—but when you get a letter of regret, just send us the short items and we'll fill them mighty quick.

All over the country, the big dealers now depend upon us for this sort of service. And we're glad to get the business. Just send us the orders your regular Victor Jobber can't fill.

Koerber-Brenner Company



Victor Distributors

Saint Louis



Harry G. Koerber
President & Treasurer

Edwin C. Rauth
Vice-President & Secretary

THE TRADE OUTLOOK NEVER BETTER IN MILWAUKEE.

Crop Conditions and General Spirit of the People Indicate That Talking Machines and Records Will Be in Great Demand This Fall—Plans of the Badger Talking Machine Co.—Summer Advertising—Leading Jobbers Report Business Expansion.

(Special to The Talking Machine World.)

MILWAUKEE, Wis., August 10.—Plans for a big fall trade are being made by Milwaukee jobbers and retailers and there is every indication that these preparations will not be made in vain. Jobbers say that dealers all over the State have rather light stocks of both machines and records on hand, and that more active buying will start at any time. Just at present dealers are inclined to buy only for their immediate needs, but even this trade is amounting to a considerable total, according to jobbers. The outlook was never better than it is at the present time. A bumper crop is being harvested in Wisconsin and surrounding States, and this is naturally going a long way toward increasing general confidence. The corn crop seems to be in excellent condition all over the State, and this will go a long way in furthering prosperity. Industrial conditions in Milwaukee are showing steady improvement. Most of the large machinery manufacturing plants are now operating from 65 to 80 per cent. of their normal capacity, which is a decided improvement over conditions which existed a couple of months ago.

Promotion for Paul A. Seeger.

Paul A. Seeger, manager of the Victrola department of the Edmund Gram Piano House, is slated for the first vice-presidency of the Edmund Gram Piano Co., the successor to the Gram-Richtsteig Piano Co., and operating the factory which is manufacturing the Edmund Gram pianos and players at Winnebago and Eleventh streets. The stockholders of the company will meet within the near future and complete the organization of the concern by the election of officers. Mr. Seeger is now enjoying a vacation of two weeks' duration with his family and other relatives at Sister Bay, Wis., a well-known summer resort on Lake Michigan.

Good Sales of Edison Disc Phonographs.

Officials of the Flanner-Hafsoos Music House, 417 Broadway, have been making some good sales of the Edison disc phonograph, even during the hot summer months. Both Eric Hafsoos and Florian F. Flanner, members of the firm, are enthusiastic regarding the possibilities to be derived from the talking machine line, and are encouraging their salesmen to push this business in connection with the piano trade.

Continue Advertising Campaign.

Most of the Milwaukee talking machine houses have been continuing the campaign of advertising which was started earlier in the season in the effort to keep business up to the normal mark, despite the hot weather and the depression in some lines. The J. B. Bradford Piano Co., the Edmund Gram Piano House, Gimbel Bros., and the Boston store, all featuring the Victor line; the Flanner-Hafsoos Music House, the Charles H. Schefft & Sons, and the Edison Shop, handling the Edison goods, and A. G. Kunde, carrying the Columbia,

have been carrying on a persistent campaign of advertising in the Milwaukee papers which has been bringing results.

Another Piano House to Handle Talkers.

It is rumored that another of the large downtown piano houses is seriously considering the plan of taking on the agency for a well-known line of talking machines. Those piano houses which have added a talking machine line have been meeting with such success that it has been encouraging other houses to follow the same plan.

Victrola Music for Picnic.

One of the most popular features of the annual picnic of the employes of the Espenhain department store in Milwaukee recently, was a Victrola furnished by John H. Becker, Jr., manager of the Victor department of the Hoeffler Manufacturing Co. Mr. Becker was formerly manager of the Victor department at the Espenhain store, when this department was in operation, and it had always been his custom to furnish a Victrola for the various gatherings of the store employes.

Using Street Car Advertising.

The George H. Eichholz Co., featuring the Victor line, at 542 Twelfth street, has been securing wide publicity and has been doubling its business as a result of the campaign of street car advertising which it is carrying on. An attractively written card, bearing the pictures of both members of the firm and a Victrola, is to be found in nearly every car in Milwaukee.

Advertising Pays.

Persistent advertising, combined with unusual personal efforts, is bringing C. W. Abbott, manager of the Victor department at the Boston store, a business which is showing a decided gain over the summer months of 1913.

Badger Talking Machine Co. in Charge.

The Wisconsin Talking Machine Co., formerly jobber for the Victor line and the former McGreal retail store, one of the well-known downtown Victor shops in Milwaukee, were taken over last month by the Badger Talking Machine Co., launched with a capital stock of \$50,000 by George F. Ruez, of Ishpeming, Mich., Samuel W. Goldsmith and Harry A. Goldsmith. The jobbing business is being conducted under the name of the Badger Talking Machine Co., and the retail store, at 312 Grand avenue, under the name of the Badger Victrola Shop. George F. Ruez has been elected president; Samuel W. Goldsmith, vice-president, and Harry A. Goldsmith, secretary.

The jobbing and retail business had been purchased only recently by C. M. Backus, of Chicago, from Mrs. Edward Yockey, formerly Miss Gertrude F. Gannon, but Mr. Backus decided to confine his attention to his real estate and loan business in Chicago and so disposed of his talking machine interests. The change places the business in the hands of three most enterprising and

capable young men. S. W. Goldsmith, who will have general charge of the jobbing business, is well known in the Wisconsin trade, having traveled over the field for the Victor Talking Machine Co. for several years. Both H. A. Goldsmith and George F. Ruez have been engaged in the brokerage business. H. A. Goldsmith will pay particular attention to the retail store, but will also assist in the general management of the jobbing business. Mr. Ruez, the president of the company, will move to Milwaukee within the near future and will take an active interest in the business.

Harry R. Fitzpatrick, formerly manager of the Wisconsin Talking Machine Co., who made a host of friends in Milwaukee and about Wisconsin during the years that he was engaged in the jobbing business, has gone with his wife to Philadelphia, his former home. He will either resume his position of traveler for the Victor Co., a position which he formerly filled before coming to Milwaukee, or will become a Victor jobber at some point.

Adding Many New Dealers to List.

William A. Schmidt, general manager of the Phonograph Co., of Milwaukee, jobber in Wisconsin and Upper Michigan, has been making good use of the summer months to establish new Edison disc dealers all over his territory. The Edison line has been in good demand for this season of the year, and Mr. Schmidt is confident that the coming fall trade will establish a new high mark. Mr. Schmidt expects to leave on his vacation during the latter part of August. William Idle, traveling wholesale representative in Wisconsin and northern Michigan, has returned from his vacation spent at his home near the Edison factory in the East, and is again on the job.

Summer Trade Ahead of Last Year.

The Gensch-Smith Co., 730 Grand avenue, featuring the Victor line, has not been experiencing any of the usual summer dullness, as sales made during July and August have been more than double those of a year ago.

EDISON DISC LINE IN BIRMINGHAM.

(Special to The Talking Machine World.)

BIRMINGHAM, ALA., August 7.—One of the most recent of the prominent houses in this vicinity to take on the Edison disc line is the large department store in this city of Foreman, Joseph & Loeb, which sent its initial order this week. This store, which is one of the finest in the South, has an attractive department for the display of Edison disc products and has already closed quite a number of important machine and record sales. Their account is being taken care of by the Silverstone Music Co., St. Louis, Mo., well-known Edison distributor.

According to the latest advices received in the East, quite a large number of progressive dealers in California have arranged to handle the Edison disc line. This fertile field is receiving the careful attention of "boosters" of the Edison disc product, with the result that new accounts are being signed up regularly. Among the most recent are the following: Wilson Music Co., Pasadena; Merle & Son, Escondido; William Torkington & Son, San Andreas; John Breuner Co., Sacramento.



Elbert Hubbard, writing in the July issue of "The Fra," says of the Little One-Der attachment for talking machines: "It restores lost chords and takes the wreck out of records." This is only one of the many very strong endorsements we have received for our patent needle holder (shock absorber)

from the hundreds of delighted owners of talking machines. A \$10,000 man writes that he is able to play perfectly with the Little One-Der attachment records 10 years old.

Here is a "Little Hint" for the dealer: In addition to trying out a sample on your own perfect demonstrating machine, using perfect new records, and getting demonstrations of the fine color-value, ask your customers to bring in their old records.

You will thus make a sale of an attachment and yourself get enthusiastic over our patent.

You will bring old customers into your store to investigate, and it is a simple matter then to get them to try out some of the new records. Result,

sale of a Little One-Der and of several new records.

Another way to sell attachments, if you cannot induce all your customers to come in for a demonstration, offer to send one out to the home for trial. We guarantee you will make a sale every time.

Write for 2 or 3 dozen attachments, which we will send on approval. At the end of 30 days return those you have not sold, and we will not charge you for them. Our introductory price on this trial offer is 60c. each, and you retail for \$1. Special price on quantities.

Sole Maker

A. S. B. LITTLE
Nashville, Tennessee



LOUIS XVI
Model A450, Circassian Walnut, \$450.00
Model A400, Mahogany, \$400.00



SHERATON
Model A27, Mahogany, Plain, \$200.00

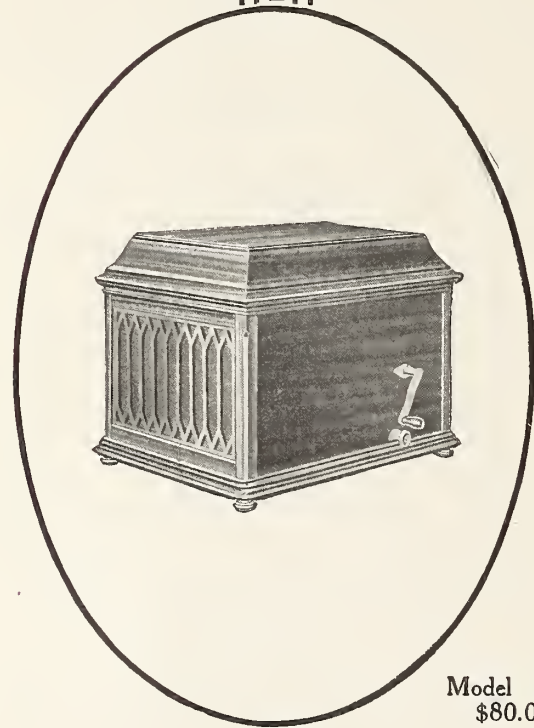

Model A80, Mahogany, \$80.00

Think About Your Different Kinds Of Customers As Well As Your Line

Look at the goods you carry through other people's eyes. Don't try to fit your customer to your line. Sell the line that fits *all* your customers.

Edison Phonographs **DIAMOND DISC** and **AMBEROLIS**

give you all the different kinds of phonographs which you need for all your different customers. They give your customers so unequalled a variety in Types, Models, Designs and Prices that their choice can never hesitate between the Edison and some *other* phonograph—it concentrates instantly on the Edison Line because its very size tells them that *some* where in that great line is the phonograph that *they* want.

Thomas A. Edison, Inc.



Model A200, Mahogany and Oak, \$200.00



Model A30, Circassian Walnut, \$300.00



ATON
290, Ma-
Inlaid
quetry,
00

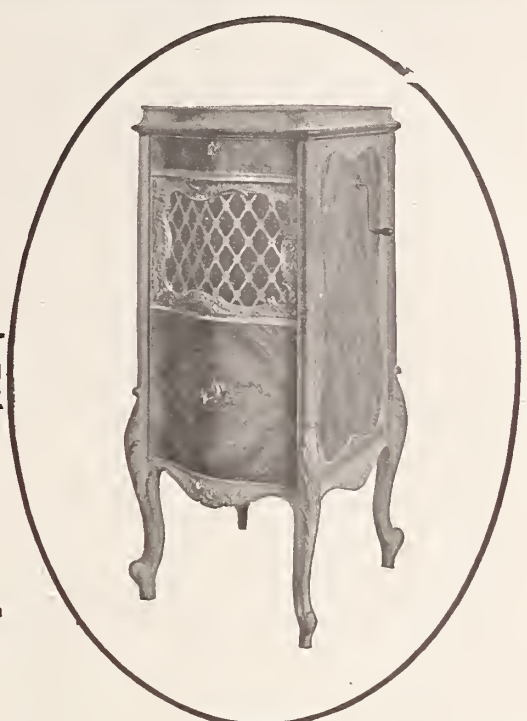

LOUIS XV
Model A425, Circassian
Walnut, \$425.00
Model A375, Mahogany,
\$375.00

Seven Customers Whom You Can Sell Right Away

Seven will buy Edison Phonographs from you right off the reel—and each one buy for a different reason. These seven buyers are:

- The one who wants no bothering with needles.
- The one who wants *all* the original music, overtones as well as fundamental tones.
- The one who wants long playing records.
- The one who wants records that the children won't break.
- The one who wants steady speed and steady pitch.
- The one who wants the only phonograph whose tone is suited to outdoors.
- The one who wants his cabinet to match his indoor furnishings.

You want each of these seven customers to bring in seven more, and each of those bring in still another seven, then you want the *full* Edison Line. Get in touch with your nearest jobber. Write us for his name now—to-day.

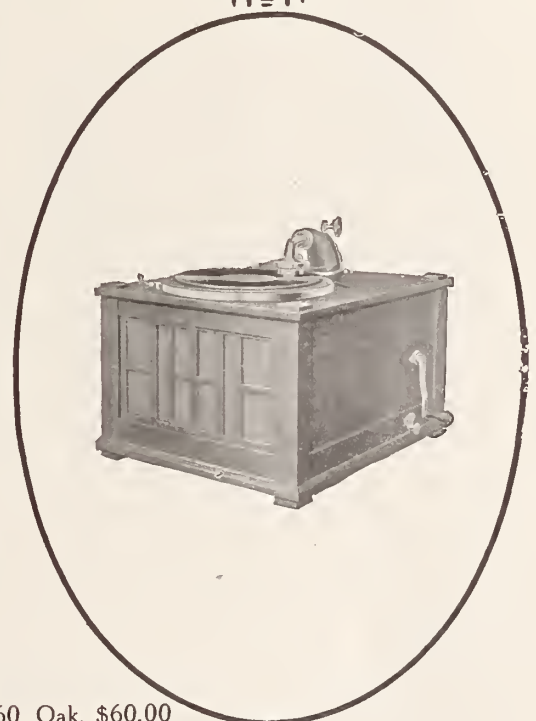

Model B60, Oak, \$60.00

Lakeside Ave., Orange, N. J.



250, Ma-
and Oak,
00



Model A150, Mahogany
and Oak, \$150.00

The **TALKING**
MACHINE
WORLD

For the makers & sellers of talking machines

EDWARD LYMAN BILL, - - - Editor and Proprietor.

J. B. SPILLANE, Managing Editor.

Trade Representatives: GLAD. HENDERSON, C. CHACE, L. E. BOWERS, B. BRITAIN WILSON, A. J. NICKLIN, AUGUST J. TIMPE, L. M. ROBINSON.

Boston: JOHN H. WILSON, 324 Washington Street.
Chicago Office: E. P. VAN HARLINGEN, Consumers' Building, 220 South State Street.
 HENRY S. KINGWILL, Associate. Telephone, Wabash 5774.
London, Eng., Office: 2 Gresham Buildings, Basinghall St. W. LIONEL STURDY, Manager.
Representatives for Germany and Austria: VERLAG NEC SINIT, Berlin C. 19, Ross-Strasse 6, Germany. GEO. ROTHGESSER, Director.

The Talking Machine World has regular correspondents located in all of the principal cities throughout America.

Published the 15th of every month at 373 Fourth Ave., New York.

SUBSCRIPTION (including postage), United States, Mexico, \$1.00 per Year; Canada, \$1.25; all other countries, \$1.75.

ADVERTISEMENTS: \$3.00 per inch, single column, per insertion. On quarterly or yearly contracts a special discount is allowed. Advertising pages, \$100.00.

REMITTANCES: should be made payable to Edward Lyman Bill by check or Post Office Money Order.

NOTICE TO ADVERTISERS.—Advertising copy should reach this office by the first of each month. By following this rule clients will greatly facilitate work at the publication headquarters.

Long Distance Telephones—Numbers 5982-5983 Madison Sq.
 Cable Address: "Elbill," New York.

NEW YORK, AUGUST 15, 1914.

BANNER crop products, now practically assured, are aiding business everywhere. Americans, almost to a man, are anxious to go ahead, and it would seem that the reports which indicate a record-breaking wheat yield, a good corn crop and a generous yield of all others would help along business very materially, and should do away in a large degree, if not completely, with the business gloom which has depressed the country during the past few months.

Certainly every business man in every part of the country, in every trade, should be interested in doing his utmost to get the gloom and grouch out of his particular locality. In other words, to get men out of the pessimistic rut, for the more we talk hard times or the effect of European wars the more we emphasize them and the longer they will remain with us.

Now why not discuss the other side? Why not emphasize the fact that the natural resources of this country are greater than ever?

Why not emphasize the fact that the crops, which promise to be most abundant, will add from ten to twelve billions to the wealth of the nation? Whether it is ten or twelve it does not matter, because a billion is a tidy sum.

Why not emphasize the fact that the business men who create the industrial wealth of the country were never so mentally equipped before in their lives?

Why not emphasize the fact that they are ready to increase their business and increase their sales in every possible way?

The President says that the depression in business is "merely psychological." Call it what you will, but let us get out of the state of mind whereby we emphasize business depression in such a prominent way.

The great essential in everything is confidence; and it is confidence in the management of the great industrial affairs which makes for success, and public sentiment based on the confidence of the American nation to do things will loom up larger and stronger than any men or set of men who may be placed temporarily in charge of the political destinies of the nation. Therefore, instead of talking depression, and going around with bowed heads and sorrowful tones, why not emphasize the big resources of the country?

Why not go at business with a gingery touch which makes for success?

THE talking machine trade has been particularly fortunate over any other line which we may mention. Possibly this

may be due to the dance wave which has swept over the entire country.

Be that as it may, the fact remains that the talking machine industry has been peculiarly blessed, not only during 1913 but the first half of the present year as well. Business has been ever increasing even when other industries have been declining.

Of course, this cannot forever go on unless the general conditions be prosperous as well, because every industry is in more or less sympathetic relation with every other industry; and while our lawmakers are evidently not in touch with the necessities of the business interests of the country, yet it is not probable that the great force of public opinion will fail to influence the lawmakers of the land.

The talking machine men have been blessed in many ways, and there is no reason why there should be any influence injected which should detract in any way from the stability of trade.

There is no good reason why dealers should announce in the daily papers that a talking machine can be purchased for so many cents a day. It has the effect on the public mind to cheapen the talking machine, and that is the very thing the men who are directly interested in its future should avoid. The talking machine should not be cheapened, and to our minds the public should not be encouraged in the belief that talking machines can be purchased for a mere trifle per day. Better a mighty sight to educate the public to the fact that talking machines are on a dignified plane and not upon a bargain basis. They are sold on strict business principles—sold at their real value and at fixed prices, and there is no reason why ridiculous monthly payments should be accepted when machines are sold on the deferred payment plan.

There is no good reason why interest clauses should not be inserted in every talking machine lease.

Simply why?

Because it is good business. It is healthy and it is keeping business up in a dignified manner, where it should ever remain.

TRADER stability should be encouraged by every talking machine association in the land, and dealers in the great cities should form local talking machine associations. These could be extended in territorial area, so that practically all of the trade might be gathered together with local associations covering the entire country.

In this way many matters of interest could be discussed and business principles which make for permanent betterment would be rigidly adhered to.

There are some men who need education.

No doubt about that; and in order to secure the dollar of to-day they would be willing to sacrifice the dollar and a half of to-morrow.

After all, business in every line can be built only through a process of education.

When the attention of men is drawn to a variety of ways in which a product may be successfully exploited they see it in a different way, and there is where the influence of local associations comes in. It not only generates a healthful and more friendly spirit, but it makes men see the necessity of buttressing their business future about with all of the strength possible.

PRICE maintenance has been the sheet anchor of the talking machine trade.

The Supreme Court, by a decision hardly understandable to the lay mind, has said that the maker of a nationalized product has no right to say how much the retailer shall ask the public for it, and yet the Government compels the railways to maintain one price for all, and would not this provision prevent the manufacturer of a trade-marked article from doing the same thing which the Government exacts from the railroads?

With a standard trade-marked article the small dealer can meet in successful competition the large merchant who has millions of assets and who cannot offer a standardized article at a less price than the little fellow who may occupy some small store in close proximity to his great competitor.

Congressman McCoy stated before the talking machine men at Atlantic City, while discussing the Stevens bill, that the believers in fixed prices would probably have to accept a provision

which provides that prices fixed for any article shall be reasonable, and he said that fear of unreasonable prices is one of the things that has influenced Congress thus far. In fact, he added, that under monopoly, or partial monopoly, prices are raised to an unreasonable height.

We can hardly say that the correctness of this assertion is borne out by trade history.

In any line fixed prices for national products have not brought about unreasonable prices, and so far as we are able to determine fixed prices are not brought about by unreasonable pricings.

NATURALLY, we are interested in the permanent success of the line to which The Talking Machine World directly appeals; but if price maintenance were not right in principle it would not appeal to the talking machine trade any more than to any other. It is, however, a protection to the public against dis-

honest prices, and that one point seems to have been overlooked by the enemies of price control in Congress.

The American people will not pay more than an article is worth for a very long time, and no manufacturer can succeed in his enterprise by asking a price which exceeds the actual worth of the product offered and expect to remain long in business.

Trade expansion and trade stability are materially aided through a fixity of prices.

Much must be brought about by the power of education.

The public has been educated to the belief that fixed prices on various products has meant a standard of values, and the public expects to secure value for every dollar expended.

In the Clayton bill it is proposed to deprive manufacturers of all products, patented included, of the power to fix prices on the articles created by them. This clause appears in the bill which is popularly known as the administration measure, and which has powerful forces behind it.

STIMULATING BUSINESS BY 'PHONE.

Personal Equation Can Be Brought Into Play Even by Long Distance Use of Voice—How and When to Use This Form of Approach.

One of the most successful salesmen we know uses the telephone for an hour or more every day. And we are disposed to think that this method which proves so successful in his case might be followed by others to excellent advantage, says the Voice of the Victor. When a record customer begins to show signs of cooling off there is no better way of reawakening interest. The telephone offers the best possible substitute for a personal visit because all the enthusiasm, the good will and the magnetism that the tones of the voice convey can be conveyed over the telephone. In other words, it is vastly easier to introduce the personal equation over the 'phone than by letter or any other such method, and every salesman realizes the value of the personal equation in business.

Not long ago a Connecticut merchant, with this very idea in view, provided each of his salesmen with a separate telephone and a separate order table, putting in an exchange so that customers could immediately be put in touch with the man with whom they were accustomed to do business.

It is one thing to call up a store and complain that goods delivered were something less than satisfactory, but it is quite another thing to be able to reprove the man who was directly responsible. There is more satisfaction in it and it does more good—moreover, a feeling of mutual trust is developed more quickly than in any other way. The direct contact of individuals diminishes the likelihood of error, because personal tastes and personal abilities are more clearly understood.

Like everything else, salesmanship by telephone may be overdone—it can, indeed, become offensive, and then more harm than good will result. Call up half a dozen people haphazard and try to get an order and you will more than likely find that your efforts instead of being appreciated quite possibly will produce the opposite effect.

There must be a reason for telephoning, and the tactful salesman uses his brains in finding a number of suitable reasons. Having done that, the rest is comparatively easy.

It will occur to anyone, for instance, to call up some good record customer with a weakness for violin records and say: "By the way, Mrs. Blank, there's an exquisite record of the 'Largo' out this month by Fritz Kreisler. His interpretation is as big as the music itself, and of course plenty of tone and the clean precision that the man is famous for. I want you to hear it."

That's one reason—one opening wedge for a nice little order—and there are plenty of others.

You learn that one of your Victrola prospects is about to give a dinner, and you will run small risk of giving offense if you telephone and say: "It occurred to me that you might like your Victrola in time for your dinner. Suppose you let me send it up."

On rainy days, when most people are likely to feel a trifle blue, you may be sure that the suggestion of a few new dance records will not be taken amiss. Watch out for every little occasion and make use of it.

This sort of thing is possible only when the salesman regards his customers as business friends and makes a point of keeping in touch with their varied interests. The man who never sees and

never thinks of a customer after the store door has closed behind that customer had better leave telephone salesmanship alone. To be more exact, he had better leave salesmanship alone.



Lansing Khaki Moving Cover. Showing Ease of Adjustment.

Arrangement of Straps on Khaki Moving Cover Showing Use of Straps Going Upstairs.

No More Dust, Scratches, Bruises or Finger Prints

on your talking machines, either in stock or in delivering, for the Lansing method of protection keeps the finish of machines in perfect condition. These covers fit all makes of machines, and the straps on the outside of the covers facilitate the work of delivering. Clothe your machines with the

Lansing Khaki Moving Cover

and don't deliver them "naked." Saves time and expense of polishing, fixing scratches and other marks, and enables a perfect-finish machine to go from your store to the house without a mar. Protection in cold and hot weather, too. Place for your name and address on the outside. Price very low and sold on the "satisfaction or money refunded" basis.

Description

Made of Government khaki, lined on inside with cotton flannel. Interlined with four thicknesses of heavy felt, firmly and evenly quilted. Furnished with straps and handles to facilitate carrying. Made strongly for durability.

Send for booklet and prices. Better include a request for a sample cover, too.

E. H. LANSING

611 WASHINGTON STREET, BOSTON, MASS.

SWITKY'S

Service

With

Intelligent

Treatment

VICTOR
DISTRIBUTOR

TRADE SITUATION IN CLEVELAND.

August Opened Propitiously and Gradually Increasing Demand for Talking Machines and Records Is in Evidence at the Principal Houses—Talking Machine Used for Variety of Purposes—News of the Month.

(Special to The Talking Machine World.)

CLEVELAND, O., August 8—The close of last month was a rather quiet one in the talking machine trade, although the aggregate volume of business was large, covering all types of machines and records. August has opened rather more propitiously and trade was somewhat improved during the past week, but is considerably less than normal at this season of the year. A gradually increasing demand is noted by the wholesale dealers, accentuated by the recent establishment of an exclusive Victor distributing store, and both the retailers and wholesalers are well stocked with machines, cabinets and records and are in excellent position to meet every requirement of the trade.

Good fortune is favoring the farmers of Ohio, this year, and their prosperity will largely redound to the talking machine trade.

A great many of the lower priced machines have been sold this season to excursionists on the lake boats, to the camps and numerous lake shore resorts. Added to this demand for machines there has been large sales of records, which materially improved conditions.

Business at the Columbia Graphophone Co.'s store is moving along conservatively, although with a fairly good volume of trade. Mr. Madson, manager, said reports received from dealers throughout this section, especially in the farming districts, are very favorable. All the dealers, he said, are exceptionally enthusiastic over the prospects of a big fall trade.

Conditions with the Eclipse Musical Co. are reported favorable. Mr. Lane, manager, said: "Vacationists are returning with renewed energy for the fall campaign. A Victrola furnished by the Eclipse is being used at a local theater this week very ef-

fectively. A twelve-inch record by John McCormack is played entirely through, the Victrola giving every prominent part in the act. C. H. Denslow, the progressive outside salesman of the Eclipse, has just returned from an automobile trip to Pennsylvania. He says black bass fishing where he was is fine, and that after drinking about a barrel of Cambridge Spring water he feels fine and in good condition to tackle the big fall business which we all expect to do.

Mr. Morton, manager of the talking machine department of the Brainard Piano Co., says that although business is at present rather quiet, it will undoubtedly be very good the coming fall. He says they are making sales of machines daily and have a good record trade, while the piano sales round out a most satisfactory business.

An "Ideal Garden Exposition" has been an attraction here for several days. The Columbia Co. has installed a graphophone, and with a select list of records entertains the crowds daily.

company's large piano business, results in a very satisfactory situation.

The W. H. Buescher & Sons Co. has installed a complete line of Victor goods at the new wholesale store on Chestnut street and is already doing a thriving business.

The Phonograph Co. reports business satisfactory in the entire line of Edison goods, Mr. Blom, manager, said trade was quite as good as he had reason to expect, and that Edison instruments and records were growing in favor, as the daily sales demonstrated.

The other dealers in the city are doing their full quota of business and hopefully looking forward to a large fall increase.

POINTERS FROM MANCHESTER, ENG.

The United States Consul There Tells How Talking Machines and Records Can Be Profitably Introduced in That Territory.

In a very interesting article published in the July 9 issue of the Daily Consular and Trade Reports, Consul W. Henry Robertson, stationed at Manchester, England, calls attention to the fact that talking machines and talking machine records could be profitably introduced in this prosperous district.

Referring to Manchester as a market for American goods, the Consul remarked as follows: "The Manchester consular district, with its tremendous population of well-paid consumers, should be one of the best markets in the world for American products, especially when the similarity of American and European tastes is considered. During the last year this consulate has endeavored to show many excellent openings for articles here that are not being properly pushed at present. In some cases these articles could be readily sold directly here, while in others they could best be marketed through general selling agencies in London. But the chief point is that they are in demand and that they can be disposed of at competitive prices, especially if sent through the cheaper and more direct route of the Manchester Ship Canal."

Keeps

You

'Satisfied

SERVICE

NEW YORK CITY

The Grafonola Co., which succeeded to the retail business of the Columbia Co., is sailing on the high tide of prosperity. "Business," said Mr. Routh, manager, "during July was greatly on the increase over that of a year ago, and the outlook for August is even better. I find that when you can get salesmen interested in looking for and working up future business, as well as taking care of to-day's sales, one need not worry over to-morrow's sales. I have heard salesmen, having a fit of the blues, say, 'I wish I knew where I could sell an instrument,' when within an hour's time, on the phone, he could get two or three good orders, and if he had been keeping the phone hot in his spare moments he would not be lamenting his lack of prospects. I attribute our increase in business to a great extent to the liberal use of the telephone in spare moments of our entire sales force."

Improvement in business within the past two weeks at the B. Dreher's Sons Co. is reported by Mr. Bowie, manager of the talking machine department. The talking machine trade, with the



A fall and winter season of unparalleled commercial activity is already in sight. For those dealers still inclined to linger over the Columbia proposition there never was a worse time to hesitate.



Come right in.

(Write for "Music Money," a book "full of meat" for those dealers interested in quick and frequent turnover of capital.)

**Columbia Graphophone Company
Woolworth Building, New York**

BLACKMAN ENJOYS OUTING.

Eleven Days' Automobile Trip Through the Berkshires and White Mountains Source of Pleasure—Stores Energy for Fall Campaign.

J. Newcomb Blackman, president of the Blackman Talking Machine Co., 97 Chambers street, New York, Victor and Edison cylinder distributor, returned to his desk last week after an eleven days' automobile trip through the Berkshire hills,



Between Manchester and Lake Sunapee, N. H. covering the routes and territory of what is familiarly known as the "Ideal Tour" for automobilists. This tour takes the visitor over a thousand miles of the best highways in New England and through sections which are noted far and near for their beautiful scenery.

Mr. Blackman, who was accompanied by Mrs. Blackman and their son Albert, made the trip in his new six-cylinder 1914 model "Buick" which gave him perfect service from start to finish. All of the ordinary hills were climbed at high gear, and the smooth running of the car was a source of great pleasure to the party.



While on this tour Mr. Blackman played his first game of golf, turning in a very creditable card on the Poland Springs Links. Judging from his enthusiastic reports and his expressed admiration for the game, Mr. Blackman will be an ardent golfer in a very short while. The trip on the whole was a most pleasant one, and Mr. Blackman returned to his office with a store of accumulated energy and optimism to combat the exigencies of the fall and winter seasons.

DISC PHONOGRAPH FOR ELKS' LODGE.

The G. B. Baker Piano Co., of Ottumwa, Ia., Edison disc representative, has reported the sale of a \$250 Edison disc phonograph to the Elks lodge of that progressive and hustling city. This sale adds another lodge of this famous organization to the ranks of Edison disc phonograph owners, as quite a number of sales have been closed of expensive disc models to local Elks lodges.

PROGRESSIVE JOBBERS ADVERTISE IN THE TALKING MACHINE WORLD. CONSULT THEIR ANNOUNCEMENTS.

ADVERTISING DURING "BAD TIMES."

Writer in Printers' Ink Points Out How Prominent Advertisers Increase Appropriations During Times of Depression.

Referring to the way in which national advertisers have handled advertising problems in times of financial depressions or panics, a writer in a recent issue of Printers' Ink commented thus on the policies of the Victor Talking Machine Co.: "You may remember how Hart Schaffner & Marx, instead of "cutting down expenses" that year, opened the advertising throttle wide—and their timid competitors paid in the sales they lost and H. S. & M. got.

"The Victor Talking Machine Co. met the situation similarly.

"Just to emphasize our own belief in the efficiency of good advertising, let me recall a little incident that happened during the financial scare of 1907," said Advertising Manager H. C. Brown at the Baltimore Convention.

"With the executive board of our company I sat at a little table in the office of our advertising agents discussing ways and means of meeting the emergency that threatened serious curtailment in the sales of many established lines of merchandise, and, following the suggestion of one of our officers, \$287,000 was added to the regular appropriation and made immediately available for extending our magazine advertising.

"The wisdom of this move was absolutely proven when the Victor Co. held its sales up through those panicky times and went into 1908 facing a demand far in excess of our factory capacity.

"This extra appropriation has since continued available for each year's advertising, and the results gathered each year, by which the value of our advertising is measured, will undoubtedly see it increased before any part of it is taken away."

"Mr. Brown might have added that in 1907 and 1908 the Victor Co. paid its usual 7 per cent. dividends on its \$500,000 preferred, and its usual 6 per cent. on its \$5,000,000 common stock. Also he

might have mentioned that in 1912 the Victor Co. paid 7 per cent. on its preferred, and began paying 20 per cent. on its common—and, in addition, had \$3,655,260 undivided profits.

"Do you think this would have happened if the Victor Co. had rushed to cover and canceled everything. I don't."

EDISON FOR WM. JENNINGS BRYAN.

Secretary of State Writes Enthusiastically on the Merits of the Edison Disc Phonograph in a Letter to the McKee Instrument Co.

(Special to The Talking Machine World.)

WASHINGTON, D. C., August 7.—The McKee Instrument Co., of this city, successful Edison disc representative, recently closed a sale of unusual importance and prestige when it sold a handsome \$450 model Edison disc phonograph to William Jennings Bryan, Secretary of State.

Secretary Bryan stopped in at the show-rooms of the McKee Instrument Co. a few weeks since, and after listening to two records was so well pleased with the tonal qualities of the Edison disc product that he instructed the company to send an Edison disc phonograph to his residence pending his final decision as to its purchase. Notwithstanding that the Secretary of State has had momentous matters for consideration ever since he entered the Cabinet, he evidently found a little spare time to listen to the phonograph, for he purchased it and a generous supply of records. Secretary Bryan's delight with his phonograph is outlined in the following letter he recently sent to the McKee Instrument Co.:

"I have been enjoying the Edison disc phonograph long enough to be sure that I shall like it, and from your list of records we have selected a number that please us very much. I am not surprised that there is an ever-increasing demand for these instruments. They give to families, at small cost, the best there is in music, and are a real and permanent addition to the amusements of the masses."

No Talking Machine Is Complete Without An Automatic Stop

STANDARD AUTOMATIC STOP

The Most Perfect Automatic Stop Made

NICKEL FINISH \$2.00

GOLD FINISH \$3.00

Thousands of our Automatic Stops in use over a period of two years, giving satisfaction, silently testify to the excellence of these devices.

Send 25 cents stamps for sample. Write on your business letterhead only. Place regular orders through your jobber.

STANDARD GRAMAPHONE APPLIANCE CO., 173 Lafayette St. NEW YORK

THE TRADE IN BOSTON AND NEW ENGLAND

JOHN H. WILSON, MANAGER, 324 WASHINGTON STREET, BOSTON, MASS.

(Special to The Talking Machine World.)

BOSTON, MASS., August 9.—Business up to the first of the month has been much better in the talking machine stores than one would expect; in fact, it showed a marked improvement over last summer. There has been a surprising demand from shore and country, and this despite the fact that the resorts have not been so liberally patronized as formerly. Since the first of the month, however, there has been a little falling off, due, as is the case with many other branches of trade and industry, to the scare occasioned by the declaration of war and the consequent fear of a money stringency. Now that there is a better feeling growing as to the safety of the monetary question on this side there is likely to be a general resumption of business, momentarily suspended. In anticipation of big business, many houses are considerably enlarging their facilities.

Need of a Local Organization.

Harry Rosen, the hustling School street talking machine dealer, is anxious to see some sort of an organization effected among the dealers and salesmen of the city, for he believes that great good could come through having a closer cooperation among the trade. Mr. Rosen has talked this matter over with a number of "the boys," and they are all agreed that much could be gained through a solidifying of interests such as is done among so many business men, those allied with some single industry; practically all trades have their own organizations, and the Boston Music Trade Association and the Boston Music Publishers' Association may be cited as types of organizations whose members are allied to musical interests. "And why not the talking machine business?" asks Mr. Rosen. Mr. Rosen believes that there is much yet to be learned about the business and a general exchange of ideas might prove of benefit all around. One of the especial needs, he thinks, is a more comprehensive knowledge of salesmanship, and he thinks there would be more of a future for a class of men who have just about remained stationary for years simply because they have not taken the trouble to know the business better, to study human nature, and thoroughly understand the fine art of properly selling goods. Then, again, a good organization could serve as a clearing house, and it could be in possession of a central bureau where dealers, without each making a personal investigation on his own account, could learn of the standing of those who might wish to do business with them, how they stood in their

accounts, whether they were good pay or slow pay, and so on. It is Mr. Rosen's hope that in the early fall some such movement may take definite shape; and it would be well, he believes, to first assemble a group of leading men in the business to informally discuss the feasibility of the plan. Then later a meeting of all dealers and salesmen could be called.

Columbia Changes Near Completion.

The changes in the Columbia Phonograph Co.'s Boston store, made necessary by the continuation of Avery street into Tremont street, are nearly completed, and in a few weeks, by September 1, probably, the large number of patrons will find welcome in an almost completely new establishment. Already the side of the building has been rebuilt and all the windows along the Avery street side are in place and, as previously mentioned, this will give ample light and will afford a splendid opportunity for advertising. The location under its new conditions will be an admirable one to attract people. All the demonstration booths are to be rebuilt and will be only eight feet high, and this will give a free circulation of air across the whole top of the first floor, and the sashes will be pivoted so the various rooms can be thrown in together if needed. There will be the inverted system of lighting. The tone of the warerooms will be French gray. Manager Erisman has worked exceedingly hard to make this one of the handsomest and best arranged talking machine establishments in the city.

Completes 1,400 Mile Automobile Trip.

Manager Royer, of the Arch street Victor headquarters of the M. Steinert & Sons Co., has just completed a 1,400 mile automobile trip into Canada, and he had as his guests a group of his faithful sales force, who enjoyed the trip quite as much as the hospitable host. With Mr. Royer were Frank Cunningham, Perley White and Charles Morrill, all of the Victor department, and a fifth one of the party was a relative of Mr. Royer's. The party was gone eight days, and the route lay through Keene, N. H.; Rutland and Burlington, Vt., to Montreal and Sorel, Canada, where Mr. Royer's wife is spending the summer. The return route was by way of Burlington, skirting Lake Champlain, St. Johnsbury, into the White Mountains, on to Bretton Woods and back to Boston. Much of the trip was over superb roads, and the famous King's Highway was found to be all that is claimed for it. Later, when Mrs. Royer decides to come home, Mr. Royer will again take

his Paige-Detroit car up to Canada, and the two will motor back leisurely.

Pardee-Ellenberger Co. Vacations.

Manager Silliman, of the Pardee-Ellenberger Co.'s Boston establishment, says that the demand for the Edison disc outfits has been surprisingly large for midsummer and July proved an unusual month, the business from all of New England during that time quite surprising everyone connected with the office. Mr. Silliman has not been away on a vacation as yet, but probably will plan to get off toward the end of the month. His son, H. H. Silliman, who will enter Harvard this fall, is spending the summer giving Edison disc recitals at a number of the summer hotels, and what an Edison machine can do has been ably demonstrated by him at Watch Hill, Block Island, Jamestown and Narragansett Pier. Young Mr. Silliman has certain traits, both of social and business worth, that should make him valuable to the Edison people.

Chickering Add the Edison Line.

Manager W. W. Longfellow, of the talking machine department of Chickering & Sons, in Tremont street, which has been confined to Victor outfits, has taken on a line of Edison disc machines, and already there has been considerable of an inquiry for them. The quarters at Chickering's at the rear of the second floor are quiet and exclusive, and thus one is able to have a demonstration of the machines under the best possible conditions. Manager Longfellow has laid in a large stock, so a customer has plenty of styles from which to make a selection.

In the meantime, in order to prepare for the expected large business this coming fall, the quarters are being considerably enlarged and three handsome booths are now in course of construction. These will be as soundproof as thick plate glass and walls lined with hair and paper can make them. Manager Longfellow has postponed his vacation so as to see the improvements completed before starting away. He will go to East Dennis, on Cape Cod. His brother, Ralph W. Longfellow, who is with him, has just returned from East Harwich.

Dudley Takes Columbia Line for Three Stores.

Manager Erisman reports that H. H. Dudley, who conducts a chain of stores at Brockton, Whitman and Bridgewater, has become interested in the Columbia proposition, and he has equipped all of his establishments with a large line. Davis Brothers, of 683 Washington street, who also

EDISON DIAMOND DISC PHONOGRAPHS

Are conceded to be the greatest sound reproducing machines ever made and the country is going wild about them. You ought to have this line in your store and if you will write to

THE PARDEE-ELLENBERGER CO., Inc.

Boston, Mass.

New Haven, Conn.

you will secure the complete information regarding the qualities of this line and our plan for laying out your department for the general promotion of business that will eventually mean a whole lot of profits for you.

Send for this data to-day.

Real Music
At Last

Real Music
At Last

THE TRADE IN BOSTON AND NEW ENGLAND

JOHN H. WILSON, MANAGER, 324 WASHINGTON STREET, BOSTON, MASS.

conduct stores at Providence, Lawrence and other places, have become Columbia enthusiasts, says Manager Erisman, and they have taken on a large assortment of outfits. Manager Erisman states that the July business of his store was 62 per cent. greater than July of last year.

Expects Big Fall Business.

The Eastern Talking Machine Co. is getting ready for a big fall business and is engaged in installing on the third floor a new retail department for Victor goods. The department will be finished and furnished in good taste, and some of the Eastern's competent staff will be on hand to look after the wants of customers.

To Move to More Central Section.

The Imperial Phonograph Co., now located in Doane street, reports that thus far business has proved excellent. The company feels that its location could be bettered, especially as larger quarters are needed, and in a few weeks it will move to a building more in the central part of the business section, probably in Devonshire street. The company says that it has been able to interest quite a number of dealers in its proposition and that its machines are in many homes in and around Boston.

With the Vacationists.

Billy Fitzgerald and Elton Taft, Jr., son of the manager of the Eastern Co., are on their vacation at "Camp Tisours," at Southport, Me. In a week's time Mark Reed and Ed Welch will go to the Maine camp, a place where the quartet has been for several years. John Maguire, of the same house, is in New Hampshire.

Manager White, of the Victor department of the C. C. Harvey Co., is taking a few weeks away from business. Chester J. Sylvester, who looks well after the interests of the talking machine department of C. E. Osgood & Co.'s large department store, is spending his vacation with his wife up in New Hampshire.

The traveling staff of the Pardee-Ellenberger Co. is thus distributed at this time: Robert C. Peck is in New Hampshire, after having spent his vacation pleasantly at Virginia Beach; L. H. Ripley is making a special trip to Vermont and will take his vacation in September, and Guy R. Coner has just returned from Southport, Me., and is again "on the job."

Distinguished Visitors.

George W. Lyle, the general manager of the Columbia Co., and Walter Eckhardt, the Philadelphia manager of the same company, were in Boston a short time ago, and spent considerable time looking over the changes which are being made under Manager Erisman's supervision. Mr. Eckhardt is making some changes in his Philadelphia store, and he was able to get some valuable "points" while here.

Fred Erisman, assistant manager of the Columbia Co., left to-day with his wife for a fortnight's vacation at Bethlehem, N. H.

Giving Series of Recitals.

Harland R. Skelton, of the Edison Co., is giving a series of recitals down along Cape Cod, and his fine demonstrations of the Edison disc machines have drawn crowds of people nightly to the hotels.

FELL IN LOVE WITH THE VICTOR DOG.

A Humorous Incident Which Occurred Recently at the Warerooms of the Kraft, Bates & Spencer Co. of Boston.

(Special to The Talking Machine World.)

BOSTON, MASS., August 6.—The salesmen on the wareroom floor of the Kraft, Bates & Spencer Co., of this city are still laughing over a humorous incident that occurred in the store last month. It seems that a lady, accompanied by a little girl, entered the company's store to select a player-piano. During the time that the prospective purchaser was discussing terms, prices, etc., with one

of the floor men, her diminutive daughter managed to lose herself thoroughly and adequately. Persistent search of every corner and nook in the ware-rooms failed to give up any sign of the lost "little lady" till finally the mother and the salesman, on the point of distraction, went outside the store to look up and down Boylston street. To his surprise

the salesman observed a number of spectators looking in the front window and smiling broadly, and further investigation revealed the fact that the little girl was perched on a pile of Victor records in the front window, while bestowing ardent affection upon one of the standard Victor trade-marks—a clean, white Victor papier-mache dog.

WILMOT BUYS EDISON DISC PHONOGRAPHS BY CARLOAD

How Citizens of Fall River, Mass., Realized That the Edison Disc Phonograph Had Arrived When W. D. Wilmot Held a Parade in Connection with a Big Shipment.

Everyone in Fall River, Mass., knows Wilmot, the phonograph man, so when it came to pass that his business increased so rapidly that he began buying the new Edison diamond disc phonographs in carload lots, naturally he took special pride in

the rear of the car being one of the Edison \$250 models.

Following this, he leased six big furniture vans and loaded each one to within a few pounds of the carrying weight guarantee given by the van



Carload of Edison Diamond Disc Phonographs with Fall River Boat as Background.

showing the citizens of that community how fast the sale of these goods is going. So when the first car arrived—Wilmot says more are coming—he backed it up against the Fall River boat to give it "atmosphere" and had a photograph taken of it. Brother Wilmot is seen driving the motor car, in

makers, put big signs on each one and paraded them all over the city. That they caused a hit is the least that can be said about them—the sales of Edison phonographs tells the story. Truly W. D. Wilmot is one of the live wires in the phonograph game.

Fairbanks & Son, who handle the Columbia line in Natick, Mass., have just reported the sale of four Leader Grafonolas to the schools of that city as follows: One each to the Nathan Rise School, the Wilson School, the Bacon School and the Nathan Goodnow School. This is good work

on the part of Messrs. Fairbanks & Son and indicates that they are alive to opportunities lying in the educational end of the Grafonola business.

There are three species of smiles: smiles, grins and leers. Don't get 'em mixed.

The Finish of Needles

is an important step and you will notice that all Bagshaw-made Needles have a glossy steel look—just as if each needle were like a Damascus sword. This comes from our special process of polishing, which although costing more, gives Bagshaw-made Needles the prominence in the talking machine world that is justified by the superiority of our needles.

W. H. Bagshaw
LOWELL, MASS.

Established 1870

Pioneer Needle Maker

NEW QUARTERS OF THE PARDEE-ELLENBERGER CO.

Every Modern Facility Adopted in New Home at 26 Oliver Street, Boston, for the Rapid Handling of Growing Business of This Company—Have Area Four Times as Large as Late Quarters in Batterymach Street—Are Jobbers of Edison Goods Exclusively.

(Special to The Talking Machine World.)

BOSTON, MASS., August 9.—Although the accompanying illustrations give a comprehensive idea of

Silliman was placed in charge. His only orders from the chiefs, W. O. Pardee and H. L. Ellenberger, was to "show New England dealers that

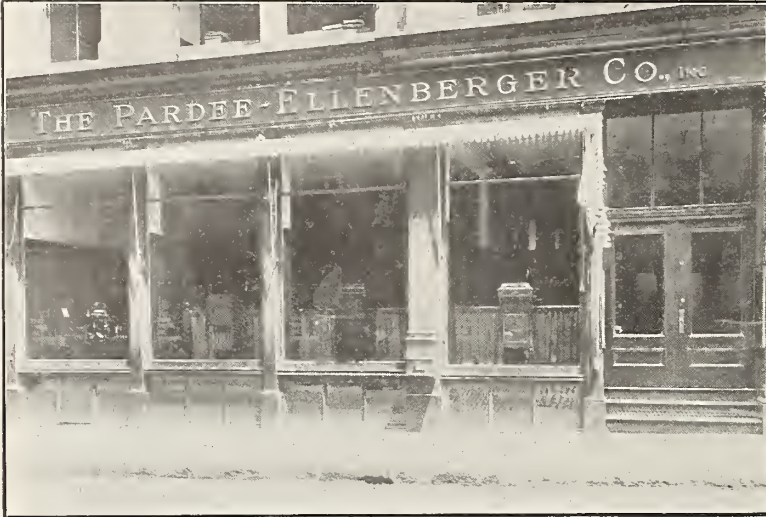

No. 1. Exterior of Pardee-Ellenberger Building.



No. 2. General Offices of the Pardee-Ellenberger Co.

the beautiful new quarters of the Pardee-Ellenberger Co., Inc., 26 Oliver street, still one should visit them to see for himself that every modern facility has been adopted in the new building of this company, so that its clients may be served in the best possible way.

When the company took over an old-established

good profits could be made by exploiting Edison goods," and it came to pass as the weeks rolled by that new dealers crept into the fold; that the business gradually extended and increased so that at the Batterymarch quarters everyone was rubbing elbows with his neighbor and the stock of goods grew so fast that the store couldn't accommodate them.

These photographs show to just what extensive scope the business of the Pardee-Ellenberger Co., Inc., has grown, and it was all accomplished by the highest quality of service. Service goes far beyond the bare exchange of merchandise for money, and is very vital for the development of "big business" to use the term.

In connection with this article it is fitting to show the executive staff of the Pardee-Ellenberger Co., Inc., Boston, Mass., and New Haven, Conn., comprising W. O. Pardee, president and treasurer; H. H. Ellenberger, secretary; F. H. Silliman, manager Boston offices, and Guy R. Coner, F. T. Keeney, R. C. Peck and F. H. Ripley—four high grade purveyors of P-E service.

INCORPORATED.

The Colonial Talking Machine Co., of Rochester, was incorporated with the Secretary of State at Albany, N. Y., recently with a capital stock of \$10,000. The parties interested are H. B. Howard, R. C. Cash and L. Weyranch.

A woman whose husband had quite unexpectedly made a lot of money returned from a trip to Europe and was besieged by friends who wanted to know about her experiences. "I've been all over the world," said the good lady; "I've seen all the al frescoes in them Dago chapels and pitchers of kings and pheasants in every city in Eurupp and the World's Fair; but to my mind there ain't anything in the art line that can touch that piece by Millet they call the Los Angeles."

A man is apt to think his latest good resolution is the best he ever broke.



W. O. PARDEE
Pres. and Treas.



F. H. SILLIMAN
In charge of the
Boston Office



H. H. ELLENBERGER
Secretary



GUY R. CONER
Salesman



F. T. KEENEY
Salesman



R. C. PECK
Salesman



F. H. RIPLEY
Salesman

Edison business here and put Boston on the map as an energetic exclusive Edison house by creating a Boston store at 66 Batterymarch street, F. H.

the interior being finished in Circassian walnut with harmonious decorations that present the appearance of a banking quarters.

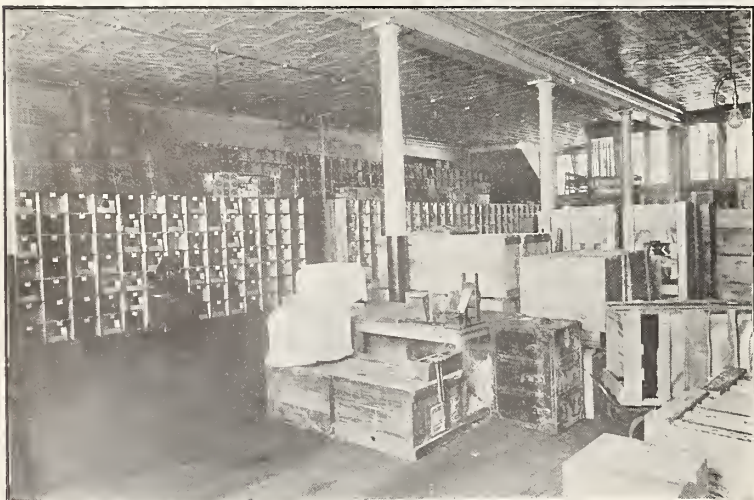

No. 4. Section of the Immense Stock Floor.



No. 3. One of the Reception Rooms.



Already 10,000 Columbia dealers—and more than enough business to go round: that's what this coming fall and winter look like. If you're not getting your share of it already, better come in on it quickly.



(Write for "Music Money," a book "full of meat" for those dealers interested in quick and frequent turnover of capital.)

Columbia Graphophone Company
Woolworth Building, New York

SOME ECHOES OF THE RECENT JOBBERS' CONVENTION

Benj. Switky, the Prominent Victor Distributer, Sets Forth His Impressions of Important and Interesting Happenings in and Out of the Session—Lesson Set Forth by Motion Picture Exhibition—Some Remarks on Loyalty—Record Problems and Solutions.

The Talking Machine World for July reported fully and conscientiously the doings of the recent jobbers' convention, but withal there is more to be said about the jobbers' association and the work and benefits of convention attendance. Replete with business and social features, there was plenty of opportunity for educational observation as well as the stimulating and beneficial effect of interchange of thoughts and ideas outside of the business meetings. It is impossible to draw a line of demarcation, separating the business from the social intercourse.

The member who attends in order to learn and profit, who goes in a receptive mood, is sure to draw inspiration from the most unexpected source and at the least expected time.

Traveling with Eyes and Ears Open.

I have been asked by certain friends in the trade to tell them something of what I saw and heard at the convention; and, strange as it may sound, one of my questioners was himself present at the convention.

To begin with, I would point out the fact that no two travelers see the same sights nor hear the same sounds, even though they be seated side by side, making the same journey. This is because of the personal equation. One's mind, eyes, and ears must be attuned responsively in order to receive vibrations in harmony with surrounding sights and sounds.

If you go to a convention in a receptive mood it is like being seated forward in a train. You see things as they approach. You have the advantage of an advance view, a side view, and, if interested, you may turn around and look backward.

If you go to a convention in a negative or an indifferent spirit, it is like traveling seated backward. You don't see things until they are past and the mental grasp is weak and deficient.

The Moving Picture Exhibit.

To me the most interesting feature of the convention program was the exhibition prepared for the jobbers and guests by the Victor Company, in the form of an educational moving picture show. To say that they deserve unstinted praise for their enterprise and disregard of expense would be to lack appreciation of the value of the exhibit. Those pictures should be shown in every city of the United States. Every dealer, every employe, even a great percentage of the public, would be grateful for the opportunity of seeing them. As an educational force, their worth cannot be overestimated. Besides, think of their advertising value!

The exhibit reproduced in every detail the processes and problems of manufacture.

The silent pictures spoke eloquently!

They answered many questions and complaints which I and others have from time to time asked and written about.

All the explanations and excuses given by the factory as to the record shortage were not half so

convincing as the ocular demonstration and proofs offered by the pictures. After seeing the special machinery required to do the work of grinding and mixing the record material; after seeing the presses, the care and time required to press each record, as well as the buffing; after noticing the skill required of each operative to insure an acceptable product, one ceases to wonder why the factory has been unable to cope with the extraordinary demands made on it for records.

After seeing all this, one is not inclined to be so harsh in criticising them and demanding that they install more presses and take on more help forthwith to take care of the demand.

One realizes that the problems of manufacturing are colossal. It is not merely a matter of doubling the number of presses and hiring enough help to man them. It takes time to break in new help to do skilled work.

Furthermore, of what use are additional presses and operatives if the grinding and mixing equipment are unable to furnish the additional quantity of record material needed for pressing?

And of what use is the machinery if there is no space for its installation? This means that new buildings are needed. At this point we must stop and admit that the Victor Company has been erecting buildings as fast as possible.

Therefore we must be patient. It is good to be unsatisfied; but let us not be dissatisfied.

All of which points to the moral that most criticism and fault-finding are the direct result of ignorance of conditions.

Loyalty to the Manufacturer.

We would also point out to the manufacturer the fact that complaint or criticism, even though based on ignorance, is *not* unfair. In the absence of proper explanation as to causes, it is but natural that men who are devoting their lives and fortunes to the business should complain or question the wisdom of policies that affect them vitally.

To answer "We are doing the best we can," should be, but is not always, a good and sufficient reply. To accept it as satisfactory requires a loyalty of an unusually high (?) order.

I question the real value of such loyalty.

There are two kinds of loyalty: The first is to accept every visitation in a "Thy-will-be-done" spirit; to accept every order and every policy as emanating from an infallible source. The other kind of loyalty is the one that seeks by criticism, by suggestion and by well-founded complaint, to improve conditions; it obeys orders intelligently, not passively. Analytical loyalty is neither socialistic nor anarchistic so long as it keeps within the bounds of patriotism and works for the common welfare along constructive lines.

Prevention and Distribution of Surplus Records.
To return to the moving picture exhibit.

As I watched the work of pressing records and recalled the discomfort and loss suffered during

the past season because of the shortage, it made my heart ache as I thought of the tens of thousands of records (up-to-date selections) listed as surplus stock by the different jobbers—records that had been pressed during the period of acutest shortage.

It seemed to me that there was something wrong somewhere. There ought to be a way of regulating the output of the pressing plant so as to supply first those selections which are needed the most.

The Transfer Bureau does noble work in distributing the surplus stock—taking away what one does not want and shipping it to the jobber that needs it.

Great as is the work of distributing surplus, it would be an even greater accomplishment to *prevent* surplus.

While the accumulation of surplus stock is not altogether avoidable, most of it *is* avoidable. The process is so simple as to seem ridiculous. The only difficulty is in getting the co-operation of those who control the situation.

If we cannot increase the output of the pressing plant, we *can* regulate its work so as to give the greatest benefit.

During April, May and June, when the factory was confining itself mostly to shipping quantities of the newest selections, jobbers were piling up surplus record stock at an unprecedented pace.

Had the factory been in closer personal touch with their jobbers and dealers—the men behind the counters—they could have served them better.

It was a mistake of judgment to presume that it meant better service to press and ship 500 of one selection than to work on 100 each of five different selections.

Giving the preference to those selections ordered in the greatest quantity tended to delay indefinitely the shipping of small orders for minor selections; hence the demoralization of the jobber's stock of catalog numbers.

The uncertainty of obtaining duplicate shipments within a reasonable time encouraged jobbers to place excessive initial orders. A condition of frenzied plunging was created, with the result that thousands of records were pressed and shipped that were destined to remain unsold for a long time, to the detriment of other selections which could have been pressed and would have found a ready sale because they were sadly needed.

Should the same policy be pursued this fall, we may expect an even greater demoralization in the record service.

The factory should encourage conservative ordering. This can be brought about by assuring the jobbers that repeat orders will be filled promptly. Under no circumstances should the first shipment of an order be held up for four weeks—or longer. As surely as this is done orders will be piled in without regard to actual requirements. Surplus will accumulate; business will suffer, and it will waste the energies and resources of factory, jobber and dealer.

(Next month there will appear Part II. of Echoes of the Recent Jobbers' Association Convention, using as a text one or two casual remarks made by fellow jobbers on the Boardwalk.)

TALKING MACHINE DEALERS OF ST. LOUIS ORGANIZE.

How an Association Was Organized and Successfully Developed—Platform on Which It Is Conducted—A. C. Thiebes, of the Thiebes Piano Co. Is President—Punishment for Those Who Break the Rules—Those Who Registered as Members of the Association.

(Special to The Talking Machine World.)

ST. LOUIS, Mo., August 12.—The Associated Talking Machine Dealers of St. Louis, with practically every dealer in the city as a member, is already making its force felt in the trade and the members are enthusiastic over the work they have planned through this organization.

The association was organized at a meeting called by Manager Fred A. Niemoeller, of the Associated Retail Merchants of St. Louis, and he aided materially in the organization work. The first plan was that the talking machine dealers should become a part of the associated retailers, but certain changes must be made in the by-laws of the larger association to permit this, and such changes cannot be made at present because so many of the directors of the retailers are out of the city. In the meantime the talking machine dealers will carry on their work with the association, of which A. C. Thiebes, of the Thiebes Piano Co., is president; Val Reis, of the Val Reis Piano Co., secretary, and A. P. Lyon, of Stix, Baer & Fuller, treasurer.

The organization meetings were about the most educative sessions the St. Louis talking machine dealers ever have enjoyed. They were very frank in their statements to each other and one confessed that of more than \$500 worth of records he had sent to one customer for approval in six months he had sold less than 7 per cent. Others told how they had been fooled into eliminating interest charges through reports of terms offered by rival houses, and these rivals were frank enough to admit the charges in some cases, but they pleaded not guilty in enough instances to show that the customers had misled them in the matter of terms.

The main points in the platform of the new association will be: Ten per cent. down on all instruments, but no cash payment to be less than \$5; records sent on approval can be kept but forty-eight hours and at least 25 per cent. must be retained or customer loses approval privilege; on new sale at least 25 per cent. of record bill must be cash; interest shall be charged on all deferred payments. No action has been taken on the thirty-day free trial of machines, but that is becoming a smaller evil daily because the houses are being imposed upon by so many persons who want machines for only a limited time, such as

during the convalescence of an invalid, while they have company for a series of entertainments and then they return them.

The first public appearance of the Associated Talking Machine Dealers was in notices placed in all packages of records sent on approval. These notices were printed without reference to any house, but were signed by the association and stated the terms of approval service.

There was some complaint during the first two weeks that some members were violating the spirit of the agreement, although complying with the text. The complaints were against offers to probable purchasers of small machines. An initial payment of less than \$5 was offered, provided the customer paid for all records. The required initial payment is \$5 on the machine and 25 per cent. of the record bill. If case was required for all records, it was easy to make the initial payment the amount of the required first payment, but stating it the other way was a salesman's trick. It is for such cases as these that the affiliation with the retailers is sought, as it is believed that an official outside of the trade and as well trained in complaints as Manager Niemoeller, of the retailers, could better police the selling situation than a tradesman whose competitors would be suspicious of his motives.

The organization was effected with excellent spirit, and dealers in all three lines joined hands in their efforts to get together and all became leaders. The downtown men were much surprised at the attendance of outside district men, and considerable time was required to introduce the dealers, as this was the first general meeting and all were surprised at the number present. The East St. Louis dealers are joining in the work.

The following are members of the association, and other dealers have applications on file:

Firm. Representative and Address.
 Aeolian Company—Wm. H. Alfring, 1004 Olive St.
 Concordia Music Co.—John D. Barthel, 912 Pine St.
 Columbia Phonograph Co.—I. W. Reed, 1008 Olive St.
 Davies Bros.—W. P. Davies, 621 N. Vandeventer St.
 Dinmore Piano Co.—Carl Brueggeman, 3565 Olive St.
 Famous-Barr D. G. Co.—James Campion, 6th and Olive Sts.
 Field-Lippman Piano Co.—Chas. F. Lippman, 1114 Olive St.
 Home Phonograph Co.—Fred Schanzle, Jr., 1807 S. B'way.
 Koerber-Brenner Co.—E. C. Rauth, 1508 Washington St.
 Lehman Piano House.—Fred Lehman, East St. Louis.
 Menzel-Tubbesing Music Co.—A. F. Mengel, 4300 Olive St.
 Scruggs-Vandervoorts-Barney—R. A. Seager, 10th & Olive Sts.
 Silverstone Music Co.—M. Silverstone, 1124 Olive St.
 Stix-Paer-Fuller D. G. Co.—A. P. Lyons, 6th & Washington.
 Thiebes Piano Co.—A. C. Thiebes, 1006 Olive St.
 Val Reis Piano Co.—Val A. Reis, 1005 Olive St.



NYOIL

For polishing
varnished woodwork it is
extremely satisfactory. No oil is so clean.

Ask your watch repairer whose
oil he uses on your watch.

NO MARRING OR SCRATCHING

Possible When Delivering or Moving Talking Machines When the Lansing Khaki Moving Cover Is Used—An Admirable Device.

After a talking machine is sold in a retail store the next problem is to get it from the store to the



home without danger of scratching or marring the highly polished surfaces, and to do so at the least possible expense.

This was the thought in the mind of E. H. Lansing, 611 Washington street, Boston, Mass., when he designed the Lansing Khaki moving cover, this being a cover that slips over

Shows Convenient Handling the machine, and by the use of straps two men can easily take the larger sized models and deliver them quickly. By the use of the Lansing cover the smaller sized machines can be delivered by messenger boy at a small cost.

The accompanying illustration shows Mr. Lansing and an assistant picking up one of the large types of Victor talking machines.

The outside of the Lansing moving cover is made of Government khaki, the inside being lined with cotton flannel. Four thicknesses of heavy felt are used for interlining, all being firmly quilted to a uniform thickness.

The straps passing underneath the machine terminate in handles half way up the side, which are held in by heavy horizontal stays. This distributes the weight entirely upon the straps, there being no weight upon either the machine or the cover.

Mr. Lansing reports a large demand for these covers from dealers all over the country who appreciate its value.

BUSY TIMES IN KANSAS CITY, MO.

Frazier-LoBello Music Co. Report Big Demand for Edison Phonographs in Its Territory.

(Special to The Talking Machine World.)

KANSAS CITY, Mo., August 6.—The Frazier-LoBello Music Co., of this city, successful piano house, which recently arranged to handle the Edison disc line, reports the closing of a very pleasing business with its new line, which, it states, is working in perfect co-operation with their piano and player-piano business. The first week that the company had the Edison disc products in its warehouses it sold five phonographs, two of these being \$200 models and one a \$250 instrument. Sales Manager Ware is delighted with the favorable impression that the Edison disc products are making with his patrons.

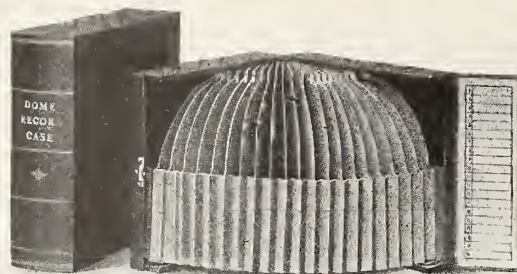

Dome Record Case

It holds 20 records, which are readily accessible for instant use. A convenient index shows just where each record is. Notice how the case swings open so the repertoire is displayed. It is constructed along different lines, being reinforced at the bottom with a nickel-plated metal support to keep the records in position.

Keeps Valuable Records Under Lock and Key

Try a sample of each, 10" and 12". If not satisfactory you may return them. Include record numbers you need and perhaps you want a particular model Victrola, which you are unable to get elsewhere. We have every model in stock.

Our shipping facilities are the best; thirteen lines of Railroad and five Express companies; also boat lines on the Great Lakes.

By sending us your order you have two of the largest jobbing stocks at your service.

W. D. ANDREWS

Buffalo, N. Y.

LOOK FOR BIGGER BUSINESS THE COMING FALL

In Los Angeles and Southern California—C. S. Ruggles Delighted with Eastern Trip—Managers of Leading Houses Are Optimistic—Electric Tablet System for Barker Bros.—Talking Machine Men Are All Most Optimistic Over the General Outlook.

(Special to The Talking Machine World.)

LOS ANGELES, CAL., August 5.—The so-called "wave of depression" seems to have dealt lightly with our beautiful City of the Angels, at least so think we of the talking machine business.

From reports of all jobbers and retail dealers business is still on the increase and the prospects for bigger business this fall are good. No place in the world do people seem to get as much enjoyment from their machines as here in Southern California, where the climatic conditions admit of impromptu concerts out of doors as well as in.

Charles S. Ruggles, local manager for Sherman, Clay & Co., has just returned from a delightful trip to the eastern coast. Mr. Ruggles took in the big convention, where he met many friends and made a great many more. He says he was treated royally by everyone and had the time of his life. He visited the Victor factory at Camden. During his absence the business was capably managed by William Campbell, his able assistant, who will not take his vacation until next September.

O. A. Lovejoy, head of the wholesale talking machine department of the Southern California Music Co., has just returned from a three weeks' sojourn in the mountains. He claims he will have to work nights to clean up the Edison business that has accumulated during his absence.

A. Graham Cook, of the Birkel Music Co., reports a fine business the last two months, especially in the large model Victrolas. They are redecorating their demonstrating rooms and when finished will have one of the really beautiful talking machine departments in Southern California.

Guy Pooler, of the Birkel Music Co., is enjoying a two weeks' vacation at the present time.

C. R. Wilson, president of the Wilson Music Co., 180 East Colorado street, Pasadena, is putting in three modern soundproof ventilated demonstrating rooms to take care of his large and growing business.

The Carlton Music Co., of Long Beach, Cal., has adopted a novel way of advertising its talking machine business. Mr. Carlton has secured the services of a small boy and a goat, and has built an attractive sandwich sign containing Victor, Edison and Columbia posters. This slips over the boy's head and rests on his wagon, and he and the goat do the rest by parading up and down the main streets of Long Beach.

V. B. Chatten, recently connected with the Musical Record Co., on South Broadway, has joined the forces of the Carlton Music Co., of Long Beach, for the summer.

J. W. Booth, manager of the talking machine department for Barker Bros., has just returned from an Eastern visit, and is quite enthusiastic over the Edison disc. While in the East he had the good fortune to meet Mr. Edison during his visit to the factory. In the near future Mr. Booth intends installing the electric tablet system in all record booths and demonstrating rooms. Any salesman wishing a record from the stock room has merely to write the number on the tablet, which in turn registers it on a duplicate tablet for the stock clerk, who immediately brings the record to him, thus making only one trip instead of two.

R. E. Daynes, of the Barker Bros. force, recently sold two Columbia Grafonola Regents the same day, thereby demonstrating the popularity of that Columbia model.

F. S. Allen, proprietor of the Musical Record Shop, has a very unique window display of dancing figures run by three talking machines. By an ingenious arrangement of mirrors the number of figures is multiplied many times. An advertisement of this kind never fails to attract and brings many prospects into the store.

T. T. Gardner, of Gardena, Cal., one of our new dealers, says he is doing a fine business in Victor, Columbia and Edison cylinder. His territory is located between Los Angeles and the beaches, and he is building up a fine trade.

Miss Alice Brown, manager of the talking machine department at Baxter & Northrup's, has just returned from San Francisco, where she spent her vacation. She is a very optimistic young lady and predicts a big increase from now on in both Columbia and Victor sales.

R. S. Odell, formerly with the F. G. Smith Music Co., of St. Louis, Mo., is now with Baxter Northrup, and is delighted with California.

The Southern California Music Co. is redecorating its extensive talking machine department. By the addition of two more rooms, formerly used by the piano department, it now has eighteen demonstrating rooms, occupying the entire third floor.

R. E. Wolfinger, in charge of the talking ma-

chine department at the Wiley B. Allen Co., reports a brisk trade in the Victor line, especially in the larger Victrolas.

The Andrews Talking Machine Co. has enjoyed its share of the summer trade, and is expecting to keep busy from now until the holidays.

W. F. Stidham, who is in charge of the Columbia Graphophone Co., wholesale, of Los Angeles, is very much pleased at the way Columbia goods are moving, especially the grands, a great many of which have been installed in the best homes in Southern California. He reports several new agencies in the near-by towns.

HEARD FROM IN LONDON.

Arthur D. Geissler, vice-president and managing director of the New York Talking Machine Co., Victor distributor, who sailed for Europe last month, has advised his office that, according to present plans, he will sail for home on the 19th of this month. During the wars abroad Mr. Geissler has been marooned in London, from which he expects to sail.



Motion Picture Dancing Lessons At Home! With the Pathéscope

THIS IS ONLY ONE OF THE MANY DELIGHTS THAT THIS SAFE, SIMPLE, AND PERFECT MOTION PICTURE MACHINE CAN BRING TO ANY HOME THAT OWNS ONE

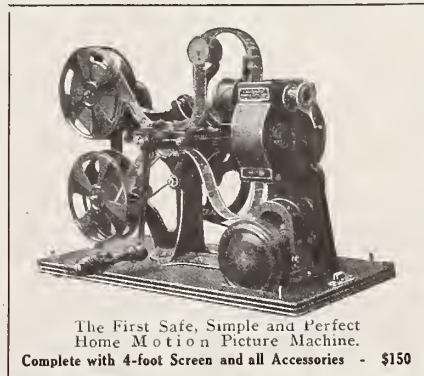

The First Safe, Simple and Perfect Home Motion Picture Machine. Complete with 4-foot Screen and all Accessories - \$150

THE Pathéscope is an extremely simple and compact, yet essentially practical Motion Picture Machine for use in the Home, School, Club, etc. It is not a diminutive model of the large professional machine, but a startlingly original design of projector, which in its simplest form is entirely self-contained, and requires no wiring, no electric connections, no equipment of any kind, but an ordinary table on which to set the machine.

By a remarkably ingenious arrangement, the simple action of turning the handle actuates the film, generates its own (incandescent) electric light, and projects the pictures in living, fascinating motion upon the screen.

For Demonstrations or Catalogue Address:

PATHÉSCOPE

Dept. 5, Aeolian Hall New York

AGENCIES: 515 Crozer Bldg., Philadelphia 1101 F St., Washington 507 American Bldg., Baltimore
459 Washington St., Buffalo 108 6th St., Pittsburgh 622 Kittredge Bldg., Denver 1516 3d Ave., Seattle

RESPONSIBLE REPRESENTATION DESIRED ELSEWHERE

An exceptional opportunity for Talking Machine Dealers to add a PATHÉSCOPE DEPARTMENT and FILM EXCHANGE, or for Enterprising Men with some capital to establish a Permanent and Profitable Business of their own. Write for Agents' Circular.

NEW YORK TRADE DISCUSSES EUROPEAN WAR.

The Effect on Business in the Metropolis and Throughout the Country Naturally Interests
—Business Up to Expectations According to Leading Members of the Trade—Optimistic Over the Outlook—New Edison Shop Near Completion—Other Timely News.

The most discussed topic in the local talking machine trade the past two weeks, as in all other lines of mercantile life, has been the frightful war now raging in Europe. Manufacturers, jobbers and dealers are carefully weighing all the pros and cons of the situation to the best of their ability, and the consensus of opinion seems to be that the war will not disturb the talking machine industry as a whole, but, on the contrary, may act as an additional tonic to increased business. Quite a number of the jobbers and dealers have members of their families or business staffs abroad at the present time, and the cables received have been reassuring in every case.

The European War and Business.

The most tangible effect of the European disturbances to date in connection with local business has been the marked increase in the demand for foreign records, particularly those selections recorded in the mother tongues of the warring nations. In certain sections of the city the dealers are unable to supply the orders they are receiving for patriotic selections in foreign languages, and should the war be protracted this demand is certain to increase by leaps and bounds.

New York is generally acknowledged to be the cosmopolitan city of the world, it being an oft-expressed axiom that in the boundaries of Greater New York there are residing more people of certain nationalities than are left in the home countries. This is, of course, an exaggeration, but well illustrates the magnitude of New York's foreign population. A large proportion of this population is available for solicitation as talking machine record prospects, and as the latest advices indicate that the reservists of several of the foreign countries will not be able to leave this country to go to the front, patriotism for the fatherland will undoubtedly be at high pitch during the course of the deplorable catastrophe abroad, and patriotic selections will be purchased for many homes throughout the land.

All of the manufacturers have European factories and branches, which will necessarily suffer materially from the effects of the war. Although no official announcements have yet been made, it is highly probable that some of these factories, if not all of them, will be obliged to shut down indefinitely. Aside from the fact that shipping is at a standstill throughout Europe, a considerable proportion of the workmen have departed for the front, with no likelihood of their places being filled before the close of the war. In times of peace the closing of the European factories by the manufacturers for any length of time would necessitate the plants in this country diverting a certain part of their output for shipment abroad, but as there is no demand for talking machines and records in Europe at the present time, and as foreign shipping has practically ceased, the European market will await the close of the war and the resumption of the factories on a normal basis.

Month's Business Up to Expectations.

In local circles business the past month has been fully up to expectations, and in the majority of instances showed a gain over last year. In the minds of many of the jobbers and dealers August is not expected to be quite as good as last year, this opinion probably being influenced by the unsettled conditions prevailing throughout the world. In any event, the first two weeks of the month have been generally satisfactory, slight losses being reported by some of the dealers and corresponding increases by others.

New Edison Shop Nearing Completion.

The new home of Thomas A. Edison, Inc., at 473 Fifth avenue, New York, is rapidly nearing completion, and all indications point to its being ready for occupancy early next month. The exterior of the building is attracting the attention of all passers-by on Fifth avenue, who pronounce the decorations as being unusually artistic and pleasing for a commercial structure. The color

scheme is gold and white, and when finished both the interior and exterior promise to be representative of modern perfection in building construction. The location of the new Edison Shop, as the building will be termed, is ideal, facing the New York Public Library and is in the heart of the best retail district of New York. The block between Fortieth and Forty-first streets, where the building is situated, is considered by many business men as the best business street along Fifth avenue, and the opening of the Edison Shop will be awaited with interest by the trade.

Collections Good with Columbia Co.

"Collections have been very good for this time of the year," said R. F. Bolton, manager of the wholesale headquarters of the Columbia Co., at 89 Chambers street, New York, "and to my great surprise are comparatively better than July of 1913, notwithstanding the business depression since the first of the year. Our dealers report a steady demand for our product, particularly in the larger machines, while the call for dance records continues to keep up at an amazing pace. The outlook as a whole for the next few months is decidedly encouraging, and I fail to see how the terrible wars in Europe can injure local business."

Optimistic Over Business Outlook.

J. Newcomb Blackman, president of the Blackman Talking Machine Co., 97 Chambers street, well-known Victor distributor, under present conditions, said as follows: "Our business for the past month shows a very nice increase over last year, and the first three months of our fiscal year—May, June and July—have been very satisfactory, showing gains over the corresponding months of 1913. I feel very optimistic regarding the immediate business outlook, and base this optimism on the fact that our country has been running on low gear so long that it is about ready for good business. The wars abroad should not injure business in this country to any appreciable extent, and eventually will work to our benefit. If exports are held up prices will be lowered, for this country will be obliged to absorb not only its natural consumption but an extra amount of vast proportions. On the other hand, if the foreign wars result in increased exports of food-stuffs, and prices are comparatively higher, busy factories and busy people will offset this. I believe that the legislation which we have had has put this country in a position to conserve its financial resources if it takes advantage of the opportunities presented."

"July Business Surprising," Says Purdy.

"July business was surprising in many respects," said H. N. Purdy, manager of the Edison disc department in the prominent piano house of Hardman, Peck & Co., 433 Fifth avenue, New York. "We had expected that trade would slow up considerably with the advent of very warm weather, and were therefore unprepared for the steady call for machines and records which we experienced the entire month of July. Record trade was especially strong, while our sales of the higher priced Edison disc phonographs maintained the high average we have had since this department first opened. In addition to selling several of the \$250 models to prominent yacht owners, we have just placed two of these machines in boat club houses in near-by cities, where they are being used for dancing purposes with great success."

Columbia Concentration on Summer Trade.

The many local representatives of the Columbia Graphophone Co. have been concentrating their activities the past months on the development of timely summer business, paying particular attention to the sale of smaller machines for bungalows, summer camps, etc., and leaving no stone unturned to build up their record sales. The results of this campaign have been gratifying to all the dealers, who state that the popular "Favorite" and the new "Jewel" machines have been sold

to vacationists in resorts throughout New York State for entertainment during vacation time. The new dance records recently issued by the Columbia Co. and placed on sale this month are creating a furore with the patrons of the local trade, according to the reports the dealers are sending headquarters.

Feeling Quite "At Home."

Back in their former quarters and feeling perfectly at home, the New York Talking Machine Co., 81 Chambers street, New York, Victor distributor, has resumed its creative work for the assistance of its dealers, and the officials are busy planning new helps for the coming fall. In the meantime business is going steadily forward, and notwithstanding the well-nigh insurmountable handicaps under which the company has worked since its disastrous fire on June 21, Sales Manager Moody reports a gain of 25 to 33½ per cent. for the month of July, as compared with last year. This is a truly remarkable record and one which looms up still more impressive when it is considered that last July was a record-breaker.

Completes New Co-operative Idea.

When a representative of The World visited the company's headquarters last week Mr. Moody was busily engaged in the completion of a new co-operative idea which will be used in connection with the company's stock system of racks, bags and stock envelopes. Mr. Moody has perfected a plan whereby the dealer may use colored labels which, when placed in various positions on the envelope, signify vital points concerning this record, such as over-stock, good selection, quick seller, etc. To further carry out the value of this plan, colors have been designed to denote various styles of records. For example, white signifies sacred, green is comic, black is bands, red is choruses, etc. Other divisions which have a separate color are male quartets, instrumental novelties, vaudeville sketches, orchestras, popular songs, etc. When the label is of a smaller size, a foreign record of a certain language is signified. It is planned to send these signal sets out with the company's regular stock outfit, besides furnishing them free of charge with all large orders for the New York Co.'s stock envelopes.

Landay Improvements.

Landay Bros., the well-known Victor distributors, are making numerous improvements to their warerooms at 563 Fifth avenue, New York, which will considerably increase their stock facilities. Additional demonstration rooms are being constructed on the main floor and new stock rooms on the sub-floor.

PAYS TRIBUTE TO THE "TALKER."

(Special to The Talking Machine World.)

NORWOOD, O., August 8.—D. S. Tarbell, a Victor enthusiast of this city, who is the owner of an exceptionally large library of Victor records, recently issued a new personal catalog, in which he pays a tribute to the Victor products in a "foreword" as follows:

"I have printed this book, just a very, very few copies, for my own particular, individual gratification, and yet, at one and the same time, have not been unmindful of the opportunity it may give me—through the acceptance of the invitation it carries to 'come and hear'—to add a bit to the enjoyment of those I especially like because of the fact that their ideas, or their lives, at least in part, run in my groove.

"The book comes into existence as a sort of observance of the thing which has so generously contributed to my life—in the morning, starting many a wrong day right; in the evening, furnishing a welcome diversion; and in the dead, lonesome hours of the night, when sleep refuses its good offices, bringing that peace and comfort and rest that neither gold nor silver can buy in any other way. Therefore, am I grateful.

"D. S. T."

Many a deckle-edged, rough-finished man has a better fibre than his evenly enameled rival.

SEE HOW THE JOBBERS IN THE WORLD CAN SUPPLY YOUR WANTS.



Do not let Your Record Stock run down

YOUR Success Depends on Two Things:

- Knowing What Your Trade Wants
- And Keeping it in Stock

Now toward the end of the busy season don't let your stock run out. Keep ahead of the demand. Send us your orders.

And special rush, "customers-waiting" orders — don't risk sending them to a jobber whose Victor stock is not complete. Any Victor article you order from us we can ship within a *few hours* of the receipt of the order.

Order Now—a Post Card Does It

NEW YORK TALKING MACHINE COMPANY

81 Chambers Street, New York

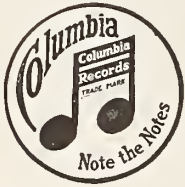

\$17.50 to \$500—that gives you \$482.50 worth of price variety in the Columbia Catalogue of Columbia Instruments: and there's good going every step of the way from one end to the other.



(Write for "Music Money," a book "full of meat" for those dealers interested in quick and frequent turnover of capital.)

**Columbia Graphophone Company
Woolworth Building, New York**

THE CHOICE OF WORDS

An Important Consideration in the Preparation of Advertising Copy.

Printers' Ink, the well-known advertising magazine, has been carrying a discussion in its editorial pages of the value of one-part or one-syllable words as compared with longer words in the preparation of advertising copy. One of the recent communications in this discussion was sent the magazine by W. G. Armstrong, of the Worcester Pressed Steel Co., Worcester, Mass., and reads as follows: "Re article in July 9 Printers' Ink, 'Words the Public Wants,' by F. R. Feland.

"Mr. Feland's article interested me, and reminded me of a piece of copy by George P. Metzger for the Columbia Graphophone Co. Here it is:

"Here's the whole story—both ends of it.

"Your end of it: You get started the first minute you are ready—no waiting for anybody. You keep it up steadily or work at it off and on as the case may be. You can talk full speed or as slowly as you like. You can correct yourself and repeat as often as you care to. In the meantime your typist is typewriting all day long—no part of the day given to note taking. If you have much dictating to do, she will have a good lot of letters already written and ready to sign before you get through dictating.

"Your typist's end of it: She reads your words, not her notes of your words. She is sure to enjoy her work better because she doesn't have to stop and wait every time you stop and think. She gets what you said, just as you said it. She can make you repeat forty times if she needs to.

"In this article there are 168 words; 137 one part, twenty-five two part, and only six three part.

"In my letters I try to use simple English—just plain Anglo-Saxon—but it is surely hard not to get lazy sometimes and let the big words work for me."

Several members of the executive staff of the Columbia Co. are sporting expensive Panama hats—hats that are 'way beyond the five or ten dollar class—through the generosity of E. F. Sause, of the export department, who recently returned from South America with the hats as souvenirs.

Large Retail Chain Stores Require **Talking Machine Managers**

Aggressive Talking Machine dealer (Victor) with chain of stores in East and Middle West, will have openings for several high class Talking Machine Managers September 1. Only men of real initiative, thorough experience and good character will be considered. Exceptional opportunity.

Applications held in strict confidence.

Address Box 650, care of
THE TALKING MACHINE WORLD
373 Fourth Avenue, New York

PATHÉSCOPE SALON IN THE JOHN WANAMAKER STORE.

Amid Artistic Environment the Pathéscope Is Shown to Crowds of Interested People at the Great Wanamaker Emporium in New York.

The Pathéscope salon in the John Wanamaker store in New York is attracting crowds of interested spectators daily, and the store's success with the Pathéscope is very pleasing to all concerned. The Pathéscope is demonstrated in ideal surroundings, as shown by the accompanying illustration,

Wanamaker Auditorium a motion picture exhibition of five reels selected from the beautiful Pathéscope photo-dramatic reproduction of Victor Hugo's deathless masterpiece, "Les Miserables." This is the same production arranged for the Pathéscope which entertained thousands of people

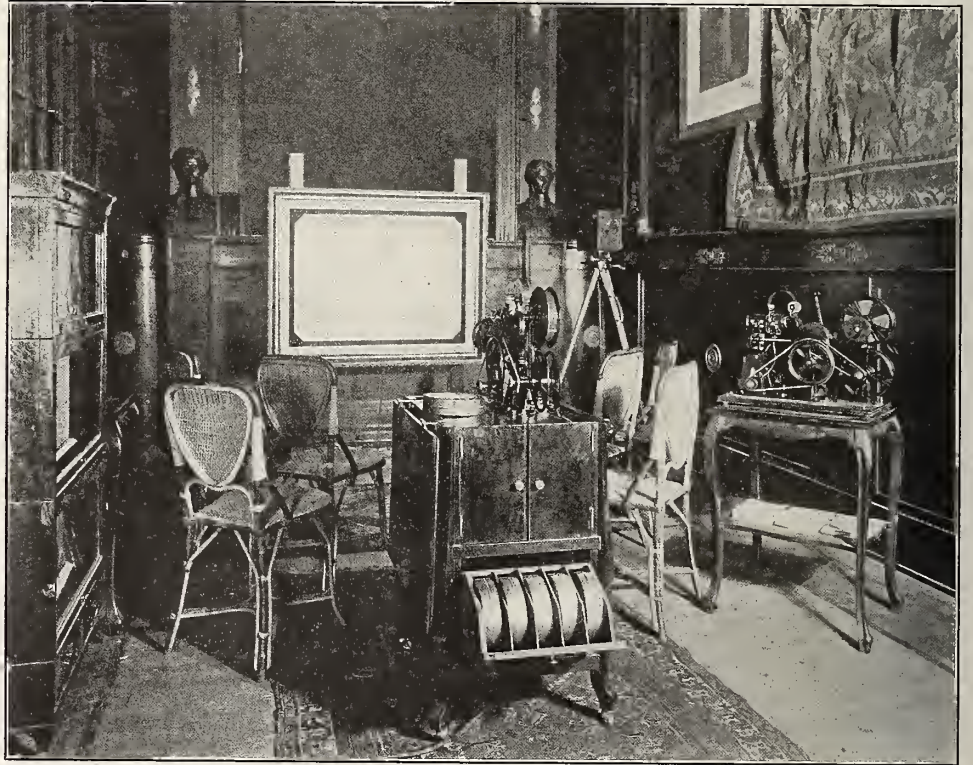

The Pathéscope Salon in the John Wanamaker Store in New York.

and the splendid publicity that the Wanamaker store is using on behalf of the Pathéscope is in accord with the high standards of this institution.

In conjunction with the demonstration of the Pathéscope there is being given between the musical numbers of the regular afternoon concerts in the

the past winter at Carnegie Lyceum, New York. The unique character of this entertainment, which is under the direction of Alexander Russell, concert director at Wanamaker's, and the perfect satisfaction rendered by the Pathéscope have made these performances unusually successful.

AN INTERESTING LETTER.

The Columbia Co. received this week the following interesting letter from a prominent dancing instructor of New Rochelle, N. Y., in praise of Columbia dance product:

"I have the most successful school of modern dancing in New Rochelle, and I want to tell you that your records have been a big factor in building up that success. My patrons prefer them—in fact many of them are insisting on them. You know by the time a pupil has had a couple of lessons or so he begins to know what he wants in music, and it is naturally to my profit to let him have it. It is, I think, a significant fact that practically every one of the records in big demand is a Columbia double-disc record. Very truly yours,
(Signed) Hazel Townsend."

STILL THEY WANT TO VOTE.

"There is a lady in this city," says E. A. Sanger, of Sanger Bros., Dallas, Tex., "who has a Victrola, and she played the 'Lucia' sextet for a friend of hers one day when her friend called on her. After playing the above mentioned record, she said to her guest: 'There is one particular record which I certainly want to get some day, but it is more expensive than I can afford at the present time, namely, the "Rigoletto" quartet, which costs \$6.' Her guest, who also had a Victrola, answered her: 'I have the "Rigoletto" quartet at home, but it only cost \$1.25; perhaps the reason I secured it for \$1.25 instead of \$6 is because mine is sung by only two voices instead of four.'"

And such things happen every day.

NEW SOUND DISTRIBUTING DEVICE.

Tones of the World's Greatest Artists Distributed Over a Large Area by Means of a Boy's Unique Invention—Some Details Regarding the New Loud Telephone—Experts Enthuse Over Possibilities.

(Special to The Talking Machine World.)

LOS ANGELES, CAL., August 5.—By the genius of two high school boys of this city the city will be enabled at a nominal cost to give to the public arias from the grand operas by the world's greatest artists. Their invention, a loud-speaking telephone, has just been perfected at the country home of Judge Charles Silent, near Glendora. The boys are Earl Hanson, aged twenty, of 2534 Fourth avenue, and Harold Silent, seventeen-year-old grandson of the Judge.

Their "central station" is the roomy country home of the Judge, from which the boys flood with melody the charming little groves and grottoes that surround the Rancho, Los Alisco.

The invention, credit for which belongs to Hanson, has been worked out by the boys together. For several years they have been studying electricity and applying it, and only recently have perfected the system whereby the voice of one person or the music from an instrument is carried in powerful volume to any part of the hundreds of acres surrounding the home.

Success was achieved by abandoning attempts to force one transmitter of a telephone to do more than has been demonstrated to be possible. They have devised a system of their own in collecting and distributing sound similar to the one employed by electric power companies. They generate a tremendous volume, which through their transformer is collected for transmission over a double wire the same as the ordinary telephone. Thus the sound is carried to be turned loose in as many places as desired. They made their first experiment with a phonograph. A large number of transmitters collect the tones and carry them to the transformer, which sends them wherever needed. The volume attainable is unlimited.

Also Dictograph Device.

The boys' loud telephone can also be used as a dictograph, so that while music in romantic corners of the woodlands might be inspiring to lovers it might also be dangerous for them to whisper endearments, as the slightest sound would be rushed back to the central station, to be distributed wherever the operator might desire.

Experts who have seen the wonderful invention of the lads are very enthusiastic concerning it, and predict a great future for it. The boys are experimenting with a wireless telephone, and expect to be able to get the same results as over the wire. Judge Silent is one of their greatest admirers and thoroughly enjoys the beautiful concerts the boys give him from the tree tops. The Judge is in hopes that it will be possible to hold municipal concerts in all the city parks through one central station.

ROSEN'S UNIQUE AND EFFECTIVE AD.

(Special to The Talking Machine World.)

BOSTON, MASS., August 8.—Local newspapers recently announced the opening of the new store of Harry Rosen, the live-wire dealer, at 246 Huntington avenue, in the following interesting manner:

"Perhaps there is nothing that pleases Harry Rosen, whose store at 3 School street has long been popular with the music-loving public, more than to announce the opening of his new talking machine parlors at 246 Huntington avenue. Mr. Rosen has built up an ever-increasing patronage by fair dealing and courteous treatment to all. From a small stock of machines and records, only a few years ago, he has made rapid strides, and it now takes a number of clerks and four times the room formerly required to handle his patrons. Among the many innovations to be found there will be a music library with its wealth of information concerning composers and their music."

PROGRESSIVE JOBBERS ADVERTISE IN THE TALKING MACHINE WORLD. CONSULT THEIR ANNOUNCEMENTS.

PITTSBURGH TRADE IN GOOD SHAPE.

Buehn Phonograph Co. Reports Substantial Business Increase During July—Good Record Made by Kaufmann Bros. Department—New Dealers Announced—Visitors of the Month.

(Special to The Talking Machine World.)

PITTSBURGH, PA., August 10.—J. A. Phelps, manager of the Boggs & Buhl Victrola department, has just returned from a two weeks' vacation spent at Dayton, O. The Ohio city is Mr. Phelps' "old home," and a restful visit spent among old friends and amid old memories constitute, in Mr. Phelps' opinion, the best sort of a vacation. Business with the Victrola department of the big store has been fair. Buying has not been as brisk as it might be, but in view of the time of the year little complaint can be made.

Business with the Buehn Phonograph Co., Inc., 713 Penn avenue, has been particularly brisk this season. July was an exceptionally good month, the business during that month being 50 per cent. greater than the same month in 1913, according to Mr. Buehn. In order to take care of this extra business and to keep up the average a news salesman, for the western Pennsylvania territory has been secured in the person of C. S. Gardner, who has already started out on his premier trip. Mr. Gardner was formerly connected with the Edison factory and is a well versed salesman of the Edison machines.

The Buehn Co. has also within the past month established connections with several more dealers

in western Pennsylvania. These include W. A. Kulp, of Braddock, Pa.; K. G. Koch, of Oil City, Pa., and Half Bros., of Homestead, Pa.

The good business of the past month is attributed by Mr. Buehn to the exceptionally good record service that has been put in force by the Edison people. The new weekly listing has been perhaps the greatest factor in boosting business, and much new trade can be traced directly to this service.

H. N. Rudderow, manager of the Victrola department of Kaufmann Bros., has brought the business up to an apex this month when a record of the best business for the past four months was established. The buying has centered chiefly on machines, and record buying has fallen off to a certain extent. Sales of the new records are good, but as machine buying has forged so far ahead, the record end has been somewhat eclipsed.

Visitors to the trade during the past month included T. B. Windsor, of Tarentum, and C. R. Kerr, of Sistrerville, W. Va.

COLUMBIA CO. WHOLESALE TRADE.

"Our business is keeping up very well for this time of the year," said H. A. Yerkes, wholesale manager of the Columbia Graphophone Co., who returned to his desk last week after a fortnight's rest. "As a matter of fact, we are enjoying quite a spurt at the present time, and the outlook for fall trade is distinctly encouraging. All types of machines are going well, with dance records in particularly heavy demand."

"BE PREPARED"

THAT IS THE "BOY SCOUTS" MOTTO

It should be every LIVE VICTOR DEALER'S MOTTO to "BE PREPARED" for the coming FALL and HOLIDAY Season.

"TO BECOME A BLACKMAN DEALER IS TO BE PREPARED"

(BLACKMAN)

Prepare to become a "BLACKMAN DEALER" by sending a few trial orders. "BLACKMAN SERVICE" will hold you.

BLACKMAN TALKING MACHINE CO.

J. NEWCOMB BLACKMAN, Pres.

97 CHAMBERS ST., NEW YORK



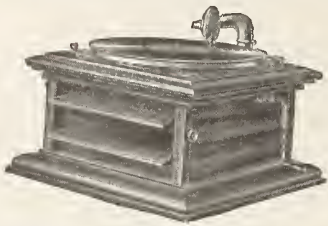

The "Eclipse"—\$25



The Grafonola "Baby Regent"—\$100



The Grafonola "Colonial"—\$150

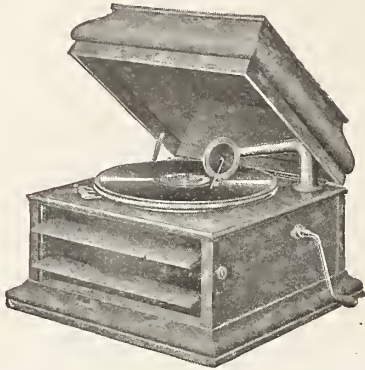

The Grafonola "Jewel"—\$35

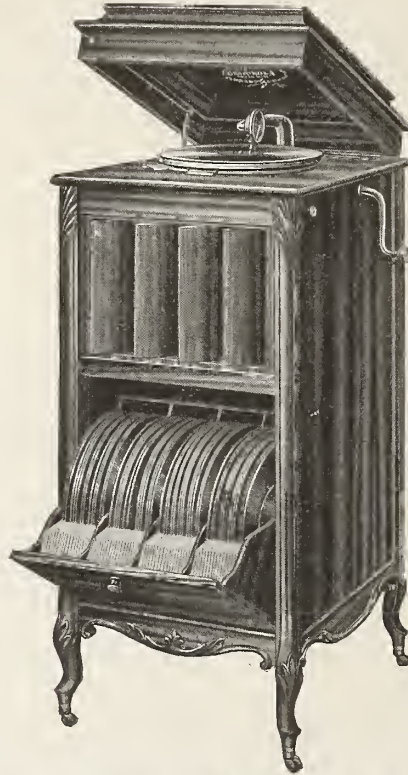

The Grafonola "Mignonette"—\$100



The Grafonola "Favorite"—\$50

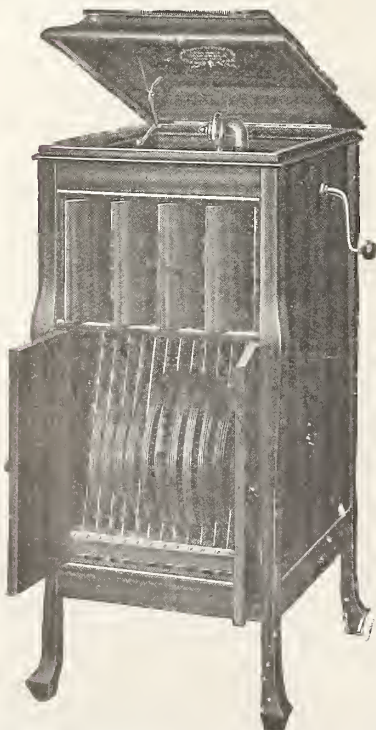

The Grafonola "Leader"—\$75

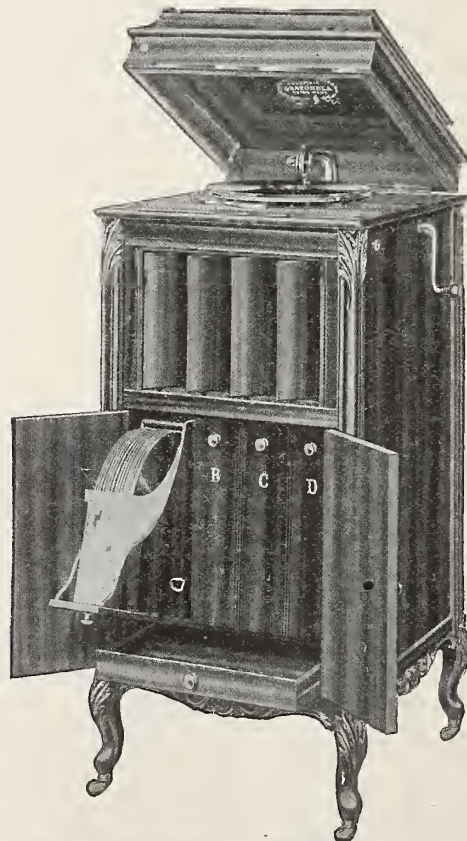

The Grafonola "Nonpareil"—\$150

Our Oppor

To-day the United States is not only the most important nation at peace, but we peace, but a vast measure of prosperity is surely indicated by our exports from our great crop-produce.

The countries of Europe cannot produce.

But they cannot cease to demand. Their demands for food, and other necessities, do not abate. It is imperative that they be supplied; it is clear that this country must do a large share of the supply.

This means that the very large amount of money that this country now sends out in return for imports from Europe, must remain in this country. It is an appreciable proportion of the money of the day which the present European countries must come into this country to purchase commodities which we alone can supply.

It behooves the American people to stand solidly; to meet the present European demand with steady industry undisturbed by any reasonless perturbation.

The promptness and efficiency of our...



Gram

Wo

(We for
deals in

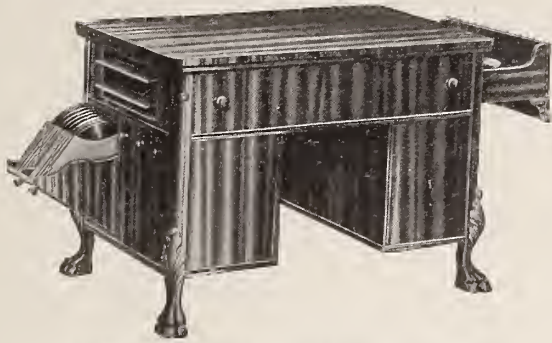

The Grafonola "Regent"—\$200

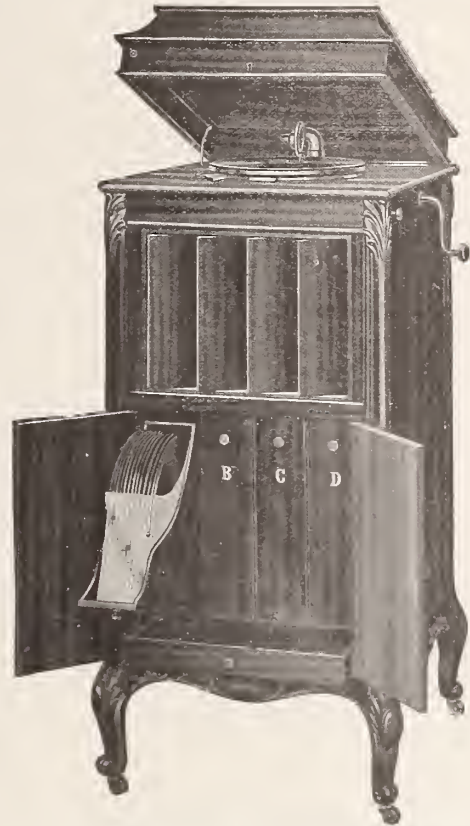

The Grafonola "De Luxe"—\$200

taken by the Government and the big business men of this country ensure the financial stability of the United States.

It is for the business men of America to avail themselves to the utmost of their temporary exaltation to the leadership of the world's production marts.

The slight, though generally declared, depression of the Summer must inevitably give way to a Fall and Winter season of tremendous activity and proportionate prosperity wherein all those engaged in legitimate commerce will participate directly or indirectly, and whence, therefore, we in the talking machine trade will reap our full share of the resultant profit.

Columbia dealers will continue to receive the full support of the Columbia producing, distributing and advertising organization.

You talking machine dealers know very well indeed that your business depends on your customer's pocket just as much as on the quality and variety of the goods you offer.

The dealer who carries Columbia product knows that he has the one grade of quality all the time; and he has the further comforting knowledge that he has something to match up in price with pretty well every pocket that is brought into his store.



The Columbia Grafonola "Grand"—\$500

COLUMBIA

Gramophone Company

Building, New York

"a book full of meat for those and frequent turnover of capital.)"

MAKING A BAND RECORD FOR THE PHONOGRAPH.

In Its Publication for Bandsmen the R. S. Williams Sons Co., of Toronto, Sets Forth Some of the Difficulties Experienced in Securing a Satisfactory Record of Band Music—Some of the Factors That Enter Into the Art of Recording Interestingly Explained.

The R. S. Williams & Sons Co., Ltd., of Toronto, distributor in Canada for the Edison products, issues a bright little paper called The Canadian Bandsman. In a recent number it printed an illustrated article on the making of band records for the phonograph, which is of such general trade interest that it is here given:

"It requires much skill to make a good band record for the phonograph. An outsider usually has the impression that a satisfactory band record is easily obtained by a band playing a tune over once or twice. But the fact is that it requires ten or twelve or even more playings to get a record that will pass muster. These repetitions are necessary in order to get the record properly balanced, for while a good recording department knows

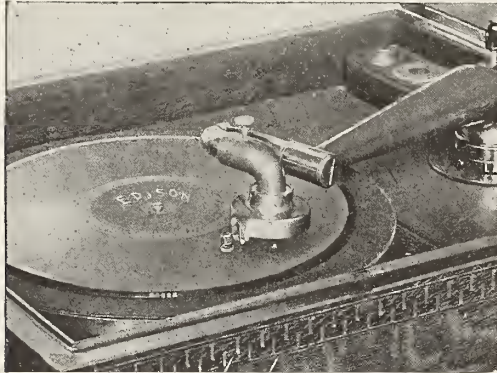

Increase Your Sales

HERE are two quick-selling specialties that appeal to your customers:

UNION TALKING MACHINE SPECIALTIES

UNION No. 2 (upper illustration) plays Edison Records on Victor Machines. No alteration is necessary. Price, gold-plated \$9.00, nickel, \$8.00, with Diamond Point.

UNION No. 3 (lower illustration) plays Edison Records on Columbia Machines without altering machine in any way. Price, gold-plated \$9.00, nickel \$8.00, with Diamond Point. Sapphire Point, \$1.50 less.

Liberal discount to jobbers and dealers

The Union Specialty & Plating Co.

409 Prospect Ave., N. W. Cleveland, Ohio



pretty nearly how the several bandsmen should be arranged before a recording horn, yet individual playing varies in force and clearness, in resonance and in good recording properties. To determine how to balance all these so as to produce a record that will give right value to all the instruments played is a high art, and one that is not acquired by an offhand playing.

"To begin with, the men selected to play in a band before a recording horn are all picked musicians—they are the very best the metropolis furnishes. This is very important, for it is a well-known fact that the slightest error made while playing in a concert, for instance, would pass off instantly with hardly any notice except by a very attentive bandmaster. But if the slightest error is made before a recording horn the band must start all over again. For this reason accurate playing must be secured regardless of expense. Each and every musician must be a soloist in his particular line. He must be expert in handling his instrument and as free as possible from mannerisms in playing.

The laboratory in which the records of the Edison Phonograph Co. does its recording is located on the eighteenth floor of a New York City skyscraper. Here quarters have been specially built for the band, where they can make all the noise they want to without disturbing other tenants of the building. Even so high up in the air, their playing is heard seven, eight or ten blocks away, and often it is a conundrum to pedestrians where the band is located.

"The record on which the sounds are recorded is known as a master record. Usually two masters are secured of any playing so as to insure against any defect in one or the other, as well as to provide for possible contingencies in the manufacturing process to follow.

"The horn used to record band music is considerably larger than the horn used for other kinds of recording. It is about forty-eight inches long and the large opening about eighteen inches in diameter. This horn is placed in a horizontal position about four feet from the floor, and the bass instruments, such as tubas, are placed at a distance of three to five feet from the horn; the altos about seven feet; the trombones about eight feet, and raised about two feet from the floor, so that they will focus the recording horn properly. Cornets are placed between trombones at a distance from eight to nine feet. The piccolos have a position between two and three feet from the horn, and the clarinets are raised two or three feet from the floor and lined up in two rows, one on each side of the horn, blowing across. The snare drums are placed two or three feet away, and are never allowed to play except when they have a solo part. Bass drums and cymbals should never be used, as they have a tendency to fog the record.

"After the artists are arranged in this position a number of recorders are selected and the band is made to play a small part of the record to each one. The results are then carefully inspected and the best records selected. A record is then made the full length and again carefully inspected and listened to in order to see that the band is properly balanced. It is very important that one instrument should not overbalance another. This is where the experience in band recording is very valuable. The diagram below will give the positions, and they will be of special interest to bandsmen.

"After two good master records are made they are carefully placed within a special tube lined with cotton felt, ends sealed up and sent to the factory to be duplicated. These master molds are handled and preserved with extreme care. They are used only to make sub-master molds and then put in a vault for safe keeping. All the records used for commercial purposes are made from the sub-masters, and in case any accident happens to a sub-master (as is sometimes the case)

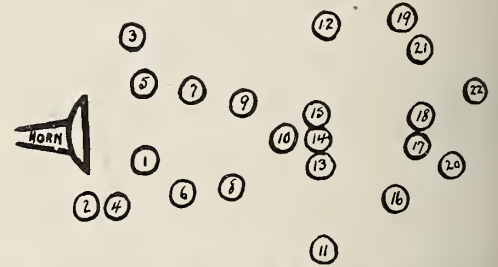

Diagram Showing Position of Each Instrument in Making a Band Record.

- | | |
|------------------------|--|
| 1—Piccolo | 12—Drum |
| 2—Oboe | 13, 14, 15—First, second and third horns |
| 3—E flat clarinet | 16, 20—Second and third cornets |
| 4, 5, 7—Solo clarinets | 19, 21—First and second trombones |
| 6—Second clarinet | 22—Brass trombone |
| 8—Third clarinet | |
| 9—First clarinet | |
| 10—Baritone | |
| 11—Tuba | |

resort is made to one of the original master records and another sub-master made from it.

"The process of making the records after a master record is obtained is another story too long to tell here.

"Many famous bands and orchestras have been recorded from the phonograph. Sousa's Band, Pryor's Band, the New York Military Band, Highlanders' Bagpipe Band, Bohumir Kryl's Band, National Military Band, Edison, Concert Band, United States Marine Band, National Promenade Band, and many others have all made several excellent records on the phonograph.

"It is possible for any band to make records of their playing before the recording horn of the phonograph and obtain excellent results. They need a good Edison phonograph, some blank wax records especially made for recording purposes, and a special recording horn. The same arrangement as outlined below for positions before the horn should be observed. If it is impossible to elevate the men as described, the different relations of the instruments can usually be made by having the tubas and altos sit down and the cornets, trombones and clarinets stand up. Considerable practice will be necessary, however, before a good

"Standard" Record Cleaner

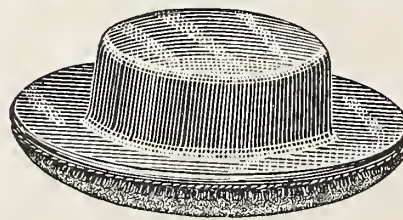

Price, 50 Cents, List
Patented June 2, 1914.

Send 10 cents in stamps for a sample cleaner. Write on your business letter head only. Place regular orders through your jobber.

STANDARD GRAMAPHONE APPLIANCE CO.

173 LAFAYETTE STREET,

NEW YORK

ARTISTIC AND ATTRACTIVE

Grips the record surface and clings as if on rails.

Extended brush area cleans record with one sweeping circuit.

record can be obtained, and much care and patience will be needed to test results as the recording is being done. When the knack of proper positions, proper blending of instruments and careful, accurate playing is secured the results will be highly encouraging and satisfactory. Such a record ought to have a value in educating those who, as amateurs, wish to bring their band playing up to the best."

EXTENDING SPHERE OF ACTION.

Koerber-Brenner Co. Combining Complete Stock and Quick Transportation Arguments in Latest Business—Show St. Louis as a Business Center in Most Artistic Supplement.

The Koerber-Brenner Co., the prominent Victor distributor of St. Louis, Mo., is carrying on a strong campaign of business expansion and calling the attention of dealers and prospective dealers in Victor goods in the Middle West territory to the quick deliveries that can be made by freight, and at a consequently low price in that section.

The special supplement of the Koerber-Brenner Co., appearing in another section of The World this month, shows a map of the United States with the approximate distances "package car" freight can be transported from St. Louis in from one to five days, which means that even quicker deliveries may be made, when required, by express and parcel post.

The Koerber-Brenner Co. calls attention to its large stocks of both machines and records, but its campaign is also interesting in indicating to what extent the business of the country is facilitated by the modern transportation systems, and how a live concern is prepared to take advantage of such systems to extend its sphere of activity.

HERE'S A NEW "TEASER."

A clever "teaser" campaign was recently carried out by the S. Hamilton Co., Pittsburgh. On one page a two-inch letter "V" appeared, on another page the letter "E," on still another the letter "C." On the following page in the same space, and in the same position at the bottom of the page was this message: 'Coming V-E-C Triplets Next Week.'

When the teaser ads had been used for a week, a 400-line advertisement announced that the "V-E-C" Triplets had arrived." The "V" stood for "Master Victor Vec," the "E" for "Master Edison Vec," and the "C" for "Miss Columbia Vec." The message was that these little people had come to minister to the musical wants of the people.

The ad read: "They bring good cheer, happiness, laughter; they will speak for you, sing for you, play for you. They will help educate your children; they will bring more laughter and sunshine into your life than all other triplets put together."

The large copy was illustrated with a motor truck carrying the three little characters described in the advertisement. The advertiser said that he was very well satisfied with the results of this copy because it created widespread comment and accomplished the publicity results for which it was intended.—Printers' Ink.

STILL IN EUROPE.

Edward N. Burns, vice-president an manager of the export department of the Columbia Co., and G. C. Jell, chairman of the record committee, who sailed for Europe late in July are among the thousands of Americans marooned somewhere in the war zone.

Geo. C. Selzer, vice-president of Harger & Blish, Des Moines, Ia., was a recent visitor to Boston in the course of a Great Lakes tour and was entertained by F. H. Sillman, manager of the Boston office of the Pardee-Ellenberger Co.

Looking inward gives you mental strabismus, a peevish personality and an ingrowing disposition. Look out.

SEE HOW THE JOBBERS IN THE WORLD CAN SUPPLY YOUR WANTS.

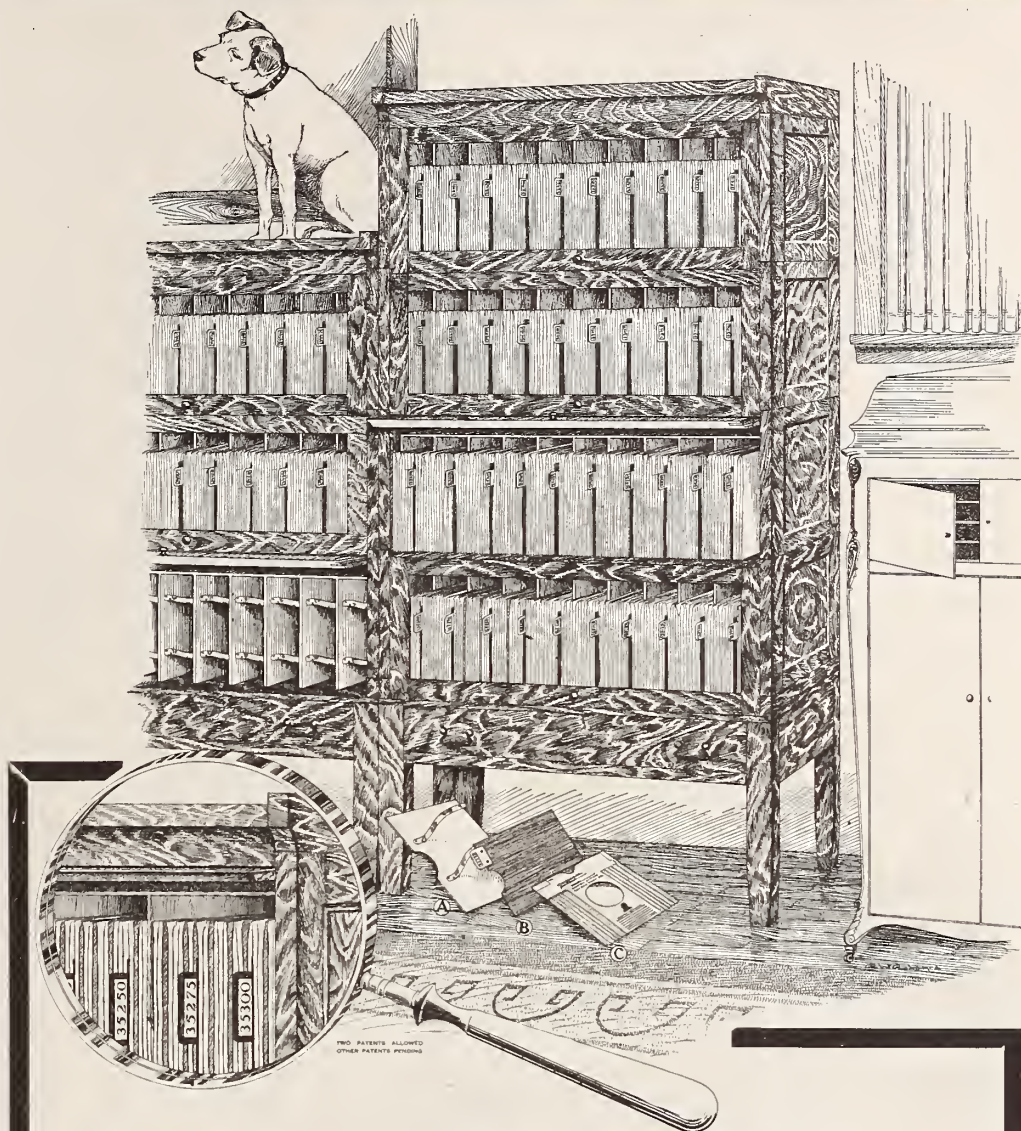

The "OGDEN"

Sectional Record Cabinet, Filing and Sales System—Proves a Wonder—The Best Yet!

Advantages of the "OGDEN" that you Can't Ignore . . .

- Saves time, space and money!
- Dust-proof — warp-proof — visible.
- Complete sales system keeps track of what you sell and what you need.
- Built of properly seasoned, heavy timber — guaranteed never to warp—will last a lifetime.
- Enables you to put your hand on any desired record in 4 seconds.
- Durable springs in each compartment hold records upright and positively prevent warping.
- Sectional feature provides for any size business—300 to 6,000 records.
- Accessory drawer in sanitary base equipped with perfect, automatic re-order system.
- Movable, numerical signals show every record instantly and permit stock to be rearranged in a few minutes without relabeling.
- Numerical signals locate every record—class signals show Songs, Quartettes, Bands, Dance Records, etc., without reference to title or number.
- Money promptly refunded if not satisfactory in every way.

Exhibited at the Atlantic City Convention and pronounced the best and most satisfactory filing system ever offered. Superior in every particular to all other filing systems. Aside from the filing system, the accessory drawer in sanitary base is equipped with automatic re-ordering system.

Explanation of Cut

"A" is a partition showing the double springs that hold the records upright and prevent warping. "B" is a numerical divider and signal that tells you where any record desired is located. This signal is movable, and once your cabinet is arranged it stays arranged, regardless of increase or decrease in stock—no change of labels required. "C" is a sales system envelope that keeps a complete record of sales and automatic inventory, showing the profitable sellers and when to cut out "slow sellers." The magnifying glass shows the method of using the signal system.

Jobbers are enthusiastic! Write for descriptive price list and give name of your nearest jobber

J. B. OGDEN
Lynchburg - - Va.

"Puts any Record in Your Hands in 4 Seconds"



Different buyers have different exchequers; that's why price variety is as important as quality product.

The Columbia dealer always has both.



(Write for "Music Money," a book "full of meat" for those dealers interested in quick and frequent turnover of capital.)

Columbia Graphophone Company
Woolworth Building, New York

CO-OPERATING WITH THE DEALER.

The Little One-Der Co. Supply Striking Colored Signs and Lantern Slides to Aid Dealer in Interesting Public in This Specialty.

The Little One-Der Co., Nashville, Tenn., reports an increasing interest in its device for clarifying the tone of records, and reports that, in response to its advertisement in *The World*, it has received orders from Canada, Hawaii, Bermuda, Buenos Aires and Mexico. While this shows the wide field covered by *The World*, it also empha-

PROGRESS IS THE KEYNOTE

Of the Business and Policy of I. Davega Who Has Built Up a Great Business in Har'lem—His Assistants Have Greatly Aided Him.

No. 125 West 125th street, New York City, isn't a hard number to remember. It's the site of a great big talking machine and sporting goods store; it also is the uptown agency for Ford automobiles, the latter being sold with the same exertion that is consumed in the sale of a fishing reel. But this isn't an automobile story, so we'll shift to Victor and Edison goods and tell about the house of I. Davega, Jr., Inc., which has handled talking machines for many years, not only having the jobbing rights for Victor and Edison cylinder products, but maintaining a retail department that for size and efficiency is an object lesson for dealers who like to see modern merchandising of these goods.

I Davega, the president, started in the hardware business in 1880. A man who works hard is bound to succeed, and Mr. Davega worked. He added kodaks, bicycles, sporting goods, and when talking machines came into vogue he helped introduce these

to the public. As the business grew he had to get more space and to-day the present big store is a worthy testimonial to his efforts. It's big enough to be termed a "large" store, few stores on that busy thoroughfare equaling it in size.

The talking machine, department, wholesale and retail, is under the direction of Manager Schwartz, and, possessing direct experience in the retailing of these goods, this organization is able to show a dealer just how to sell the goods efficiently, and as a rule a dealer trained by Davega is a successful one.

Although Mr. Davega keeps an active line on his many affairs, still the business is too large to be a "one man" affair, and the general executive work falls upon the shoulders of J. Florian, who is the business manager. Mr. Florian plans business moves like a man playing checkers, with a view to driving his work rather than to let the work drive him, and this systematic planning enables him to accomplish a wonderful amount of work. Every detail is closely watched by him, which explains why the business runs so smoothly.

Abram Davega, son of I. Davega, who is vice-president of the corporation, is being trained under the guidance of his father, and on account of his marked ability he is making a record for himself.

SEE HOW THE JOBBERS IN THE WORLD CAN SUPPLY YOUR WANTS.

WHAT IS ADVERTISING?

A Definition That Won the Prize Offered by the Pompeian Co.

As the result of a prize contest announced by the Pompeian Co., for the best definition of advertising, Walter I. Hamburger, of Hochschild, Kohn & Co., Baltimore, was awarded the prize of \$25 for the following definition:

"Advertising—the force which enables the modern business man to disregard the distance between himself and his prospective customers.

"The force which gives him a million eloquent tongues with which to tell his business story to the world.

"The force which enables him to create new desires and to point out new ways of supplying old needs.

"The force which, properly directed, will make a worthy business prosper, but which no matter how cleverly applied, cannot give prominence to an enterprise founded on falsehood.

"The force by which, a business may be built or wrecked, and which, in the last analysis, brings to him who uses it just that measure of success that his efforts deserve.

"Advertising—the force which has transformed the parlor melodeon into a pianola, the cracker barrel into an Inner Seal package, the crane over the hearth into a fireless cooker, and everything else in the world in like degree."

NEW COLUMBIA DISPLAY SIGN.

The advertising department of the Columbia Co. now has ready for the trade a new muslin display sign measuring 10 feet in length by 3 feet in width. The sign embodies numerous improvements over the first sign of this nature introduced by the company some time ago. The well-known Columbia trade-mark is prominently displayed and a cut of the new "Favorite" lends additional strength to the sign. The color scheme is blue and gold on a white background. It is quite attractive.

A MELBA ANECDOTE.

Madame Melba is fond of telling a curious story of her school days at the High School at Mazawattee, which foreshadowed her success on the lyric stage. On her arrival at the school with several other newcomers, the head mistress asked, "Which of you is Nellie Mitchell?" and the future prima donna replied with ungrammatical emphasis, "Me, me." As a result she was at once nicknamed "Mimi," in accurate anticipation of her ultimate identification with the heroine of Puccini's opera.

"By recent report, two new Metropolitan boxholders are paying \$200,000 each to enter the Golden Horseshoe this year," says the *New York Sun*. Only two other transfers of parterre boxes are recalled since the owning company was formed a generation ago. In those cases \$100,000 was the price. The original investment was \$30,000 for each of the thirty-five shares. Broadway's biggest theater has thus appreciated in value from \$1,000,000 in 1883 to \$7,000,000 now."



Slide for Featuring the One-Der Sound Reproducer.

sizes the interest in the products of this company.

One of the effective means of bringing the Little One-Der device to the attention of the general public is the illustration (in black and white) which is reproduced herewith. Of course it must be understood that the full effect of this illustration can only be obtained in the colored signs and lantern slides provided by the Little One-Der Co., and which, with the dealer's name inserted, forms an excellent means of publicity for the local dealer handling this specialty when featured through the local moving picture house.

A good liar doesn't weaken in the midst of a tale simply because his listener looks incredulous. He opens the muffler and goes ahead.

I. DAVEGA, Jr.

125 WEST 125th STREET, NEW YORK

Victor Distributor

PROMPT AND ACCURATE SERVICE

DEALERS: Write for our Victor Pennant. Sent with our compliments.

"TALKERS" IN CHAUTAUQUA CIRCUIT.

Educational Value of the Talking Machine Recognized in the Broadest Kind of Way.

The educational department of the Victor Talking Machine Co. recently called the attention of its trade to the marked progress that the Victor products have achieved in the activities of the Chautauqua circuit. It was pointed out that numerous directors of the Chautauqua had recognized the value of the folk-dance records issued by the Victor Co. and had recommended them for use in over 500 cities under the auspices of both the regular and junior Chautauquas.

Referring to the individual activities of the members of its educational department, this Chautauqua article remarked in part as follows:

"Then there are the Chautauquas themselves. In Minneapolis the State University has given an extension tour of Chautauquas in twenty-four towns, employing some of their best talent. One of the features of the tour has been a daily lecture on 'The Message of Music Illustrated by the Victrola,' given by our William H. Nolan and Leroy C. Case. In Pennsylvania and New Jersey our Harold D. Smith and Branson M. DeCou will give a similar course of lectures on the Junior's Eastern circuit.

"Our lecturers have engagements in some fifty of the large summer schools in normals and universities. A part of the force will hold a Victor demonstration at the National Education Association in St. Paul, while Mrs. Clark will be speaking before the National Catholic Educational Association at Atlantic City.

"Our Miss Ada G. Jordan has just appeared on the program of the Northwestern Music Teachers' Association at Portland, Ore.; Mr. DeCou is managing demonstrations at the New York State Music Teachers' Association at Saratoga Springs, and William H. Nolan is showing the Y. M. C. A. secretaries how to use the Victor in their summer camp at Lake Geneva, Wis."

PROVES VALUE OF RECITALS.

Haddorff Music House of Des Moines Adopts Plan Long Advocated by The World.

(Special to The Talking Machine World.)

DES MOINES, IA., August 7.—The Haddorff Music House, of this city, is instituting a novel idea to introduce new Victor records which is meeting with marked success. On the 28th of each month, when the new records for the following month are ready for announcement, the company sends out a postal to all its clients and prospective patrons inviting them to be present at a recital of advanced Victor records. The postal states that the recital will be held at Haddorff Hall, Ninth and Walnut streets, and the recipients are invited to bring along their friends. It is suggested that there are plenty of fans in the recital hall with which to keep cool, and refreshments are served. To date the plan has resulted in the closing of many record sales which might otherwise have been lost to the house.

LATEST PORTRAIT OF SLEZAK.

Famous Tenor Shown in Unconventional Pose at His Home in Europe.



One often hears of temperamental artists getting "up in the air," but it is rare to see a prominent artist in exactly the reverse position. The accompanying unconventional snapshot of Slezak, the famous tenor, whose records on the Columbia have proven so popular, was taken at his home in Europe, and shows how the singer spends his period of rest. Not being a dancer, the picture is interesting only as showing Slezak upside down.

NEW EDISON ARTISTS

To Be Represented in the October List Are Dan Beddoe, the Famous Tenor, and Redferne Hollinshead—Both Artists Are Represented by Some Admirable Records.

Two new artists, both singers of national fame, will make their debut in the list of concert records to be issued by Thomas A. Edison, Inc., in Oc-



Dan Beddoe.



R. Hollinshead.

tober. The first artist is Dan Beddoe, widely known in the concert and oratorio field as a tenor of distinction. He has a voice of unusual charm, range and quality, which he uses like a true artist. His number for the cylinder list for October consists of that ever popular duet, "Home to Our Mountains," from "Il Trovatore," which he sings with Margaret Keyes, a contralto, who is also widely known and appreciated for her charming personality and beautiful quality of voice. The two voices combine beautifully.

The second artist in evidence is Redferne Hollinshead, a newcomer among Edison artists, who has a voice of excellent range and sweet timbre. He is represented by two numbers, the Buzzi Paccia "Lolita," a typical Spanish serenade, and Tosti's "Parted," a love song which is sung with sincerity and pathos.

GIVES CONCERT IN CHURCH HALL.

(Special to The Talking Machine World.)

NEW CASTLE, DEL., August 7.—E. E. Bridgewater, successful Victor dealer in this city, is utilizing various progressive modes of publicity to develop and increase his already profitable clientele. One of his most recent ideas was the giving of a successful Victrola concert in the lecture room of the Presbyterian church before an appreciative audience.

LIVELY BUSINESS IN TWIN CITIES.

Difficult to Get Enough Stock in Certain Lines Is the Claim of Dealers—Big Edison Parade Attracts Attention—July Good Month for Columbia—General News of Interest.

(Special to The Talking Machine World.)

MINNEAPOLIS and ST. PAUL, MINN., August 8.—"We are selling Victor talking machines and records so rapidly that the factory cannot supply us with goods fast enough to satisfy the hungry demand," pathetically complains David M. Dyer, of the old house of W. J. Dyer & Bro. "We had an excellent trade all through July, but regret to say that we were unable to fill all the orders. It feels something like losing real money to be without goods that have been ordered, but I guess we will have to grin and bear it. Other Victrola stores like Foster & Waldo, the Talking Machine Co., relate identical tales of their woes, but the story is not a new one and hence not particularly interesting.

An Edison parade was one of the features of the Minneapolis week in musical circles. The Minnesota Phonograph Co. received seven carloads of Edison goods Tuesday (August 4) and because it was the biggest shipment of its kind into the Northwest, Laurence H. Lucker, president of the company, hired a band, also twenty-seven motor trucks and vans and had a parade. It was a most effective bit of advertising, for many spectators remarked that they did not suppose that there were so many talking machines in the world, and the appearance of twenty-seven trucks and vans loaded to the limit with phonographs made them stop and think. The Edison shop in St. Paul is a certainty and will be located at one of the most commanding retail corners in the entire city, but of this more later.

July was a much better month than June for the Columbia stores in Minneapolis and St. Paul, and the month likewise showed a substantial increase over the business of June, 1913. Except that everybody is happy and the Columbia rapidly is growing in popularity, the local managers, not even C. P. Herdman, of the St. Paul store, have much to say this week.

While bankers are showing some anxiety over the war situation, the merchants generally are not worrying. They are quite sure that there will be no serious interruptions to the business prosperity that has been heading this way for several months.

Lots of failures can be traced to the belief that other people are not quite as smart as we are.

VICTOR

A complete line of Victor products, from the smallest repair part to the biggest model of machine. Every shipment made promptly.

EDISON

Cylinder goods, machines and records; full stocks and immediate deliveries. A good popular-priced line for most any territory.

Louis Buehn

Philadelphia



Don't let the scare-mongers hobble your hopes. Crops are good; money is sound; European cash is coming this way and it looks like the biggest Fall and Winter in history.



(Write for "Music Money," a book "full of meat" for those dealers interested in quick and frequent turnover of capital.)

Columbia Graphophone Company
Woolworth Building, New York

HERZ VICTROLA DEPARTMENT

Just Opened in Terre Haute, Under the Management of Chester I. Abelowitz, Is Admirably Fitted Up to Handle Large Trade.

(Special to The Talking Machine World.)

TERRE HAUTE, IND., August 11.—The new Victrola department of the A. Herz department store in this city was opened to-day under the management of Chester I. Abelowitz. Mr. Abelowitz has had about fifteen years' experience in the talking machine business, starting at the time the Victor was first introduced to the public, when he was



New Victrola Department in Store of A. Herz, Terre Haute, Ind.

connected with this line in the East. About two years ago Mr. Abelowitz was sent to Buffalo, where he was placed in charge of the Victor department of the J. N. Adams Co., and remained there four months. At the end of this time he was sent to take charge of the Root Dry Goods Store Co. at Terre Haute, where he remained until his recent change to manager of the Victor department for the Herz store.

It is said that Mr. Abelowitz has a most remarkable memory for both the names and num-

bers of Victor records, and that if you give him the name he will give you the number, or mention the number, and he will tell you the name of almost any record in the Victor catalog. This is a wonderful accomplishment when the fact that the Victor catalog contains several thousand records is taken into consideration.

The Victrola department is on the fourth floor of the Herz store and is equipped with soundproof booths corresponding with the other fixtures in the store.

The Terre Haute Sunday Star advertised the opening of the new department in part as follows:

"Terre Haute first saw a 'talking machine' in the old Dowling Hall many years ago. An admission fee of 10 cents was charged for the privilege of inspecting the wonderful invention, a crude machine, turned by hand, and producing more or less unsatisfactory tone and voice effects by means of foil records. Tomorrow Terre Haute is to have the chance of seeing a new and complete stock of Victrolas, the remarkable sound-recording, sound-producing instruments that had their inspiration in the poor little 'talking machine' of thirty years ago.

"The Victrola of to-day brings direct to you—into your own home—the music of the world; the wonderful voices of Caruso and Melba and Tetzlaff and other stars of grand opera; the instrumental music of Kubelik and Mischa Elman and Paderewski, and others that are holding audiences spell-bound wherever they appear; the comic, sentimental and popular songs of the day sung by men and women of pleasing voice and wide reputation; the music of the master bands of the world, concerts by famous orchestras, dance music that will set your foot busy at beating an accompaniment—songs and music from every quarter of the globe, German, Greek, Yiddish, Chinese, and records in various other tongues. All yours in the secluded comfort of your own home, for the mere shifting of a rubber disc, the changing of a little steel needle and the turn of a lever. And you will not tire of the music, for every month brings a fresh supply of excellent records—a long list for you to choose from at small expense. It is this opportunity to renew your selection of records every month that keeps the Victrola ever new and ever pleasing.

With so little to be proud of, it is hard to see what makes the weather vane.

SEE HOW THE JOBBERS IN THE WORLD CAN SUPPLY YOUR WANTS.

LOVING CUP FOR MISS McGRATH.

Popular Young Lady in Executive Office of Columbia Co. Displays Her Terpsichorean Ability and Secures Handsome Prize.

Miss C. McGrath, one of the most popular young ladies in the executive offices of the Columbia Graphophone Co., in the Woolworth building, who transcribes most of the excellent copy turned out by the company's advertising department, is evidently as proficient with her toes as with her fingers, which is paying the former quite a compliment.



Miss McGrath returned from her annual vacation last week, wearing under her arm an imposing looking quart mug of solid silver. On closer investigation it was revealed that this utensil was in reality a very handsome loving-cup suitably engraved with an inscription proclaiming the fact that Miss McGrath had won the cup for her perfect tango dancing at Lake Hopatcong, N. J., after she and her partner had outdistanced all competitors. Miss McGrath is bearing her honors modestly and attributing her terpsichorean proficiency to the perfect rhythm of Columbia dance records, which she utilizes for practice purposes.

Some men are like roosters—they crow pretty well, but when it comes to work, they let others do it.

We live and learn, but those who live fastest don't always learn most.

AGENTS WANTED

We have still some choice territory open for exclusive selling rights on Little One-Der attachments (patented). Splendid side line for energetic young man. No money required. We supply 12 attachments and you pay when you get your money and send for new supply. Demonstration at customer's home means a sure sale every time. Will play any record using steel needle. Big profits, quick returns. A. C. B. Little, Nashville, Tenn.

PARTNER WANTED

Increasing demand for a new patent requires most of my time, and I want a live active managing partner, capable of handling wealthy Red Seal trade; business paying fine all summer; wealthy city of 35,000 and I have three-quarters of all the talking machine trade—Victor and Edison. Address "Partner," care the Talking Machine World, 373 Fourth Ave., New York.



Write today for our new catalogue giving you rock bottom prices of our specialties.

Springs for any kind of Talking Machines

No doubt you will find it interesting.

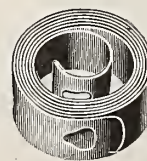

EMIL RIEDEL

Sächsische Sägen- u. Federstahlwaren-Fabrik.

Chemnitz-Gablenz, P. O. Box 10, Germany

NOTABLE TRADE IMPROVEMENT REPORTED IN ST. LOUIS

Business Slump Appears to Have Passed By—Higher-Priced Machines Have Many Admirers—Columbia Manager in the East—Eighteen Columbia Machines for Children's Playgrounds—Home from the Convention—Recent Trade Visitors of Record.

(Special to The Talking Machine World.)

St. Louis, Mo., August 11.—The talking machine trade, which has been of fair volume during the summer, has been greatly improved since the beginning of the last week in July, according to dealers here. The relief from the extremely hot weather that was so depressing during the early summer apparently revived the spirits of the talking machine users and a spirited demand for records began at once and an improved machine trade within a few days later.

A local dealer ran over his machine contracts, calling amounts, for The World correspondent. Despite the fact that his advertising recently has been pushing machines at \$50 and less, he has as many \$200 contracts in his list as \$15 ones and a large percentage more at \$50 and above than below \$50. This, despite the fact that several of the machines were especially for summer home use. This ratio probably is true of all the dealers, as they say that the very cheap machines now are purchased only for special occasions.

Jobbers say the outlook for fall trade is excellent and that advance orders being received are for excellent totals.

Harry Levy, of the Aeolian Co., has not been able to take his vacation as yet, and he declares that the fall trade has begun in such form that he is doubtful of getting away.

Manager Irby W. Reid, of the Columbia warehouses, is in the East at this writing, combining pleasure and vacation on an extended trip. He is expected to return to his desk about the middle of the month. Charles R. Salmon, manager of the local wholesale department, is occupying Mr. Reid's office during his absence and directing the affairs of the local trade. The last reports from Mr. Reid were that he had spent several days at the factory and had been the guest of President Easton, at Arcola, N. J., for a week and that he was going to tour the Eastern stores and see how Columbias are handled there and pick up any suggestions he could to push the trade in St. Louis.

Mr. Salmon said that the trade had been excellent since the newly decorated and furnished store had been placed in shipshape and that especially that improvement had been noted in the retail record sales in the last two weeks. The wholesale trade, he said, had been very good and the fall outlook is excellent indeed.

Retail Manager Durry is taking a good deal of satisfaction in an order for eighteen machines delivered to the children's playgrounds. The fact that this sale was made to Miss Charlotte Rumbold, a municipal officer who governs the playgrounds, was especially pleasing to him. Only 48 records were sent out with the machines, but that was because Miss Rumbold did not have the time to go farther through the list. She expects to buy many more records as soon as she has the opportunity. The machines will be handled by the playground instructors, all of whom are city

school teachers who accept this work as summer employment and the records used are all of an educational nature. The folk dance records are especially popular with the children. Mr. Duffy regards this sale as an especially helpful one toward promoting the use of the talking machines in the schools, for the parents visit the playgrounds frequently and become more familiar with the work there than during the school season.

In making her purchases Miss Rumbold was confronted with the necessity of making a small appropriation go as far as possible. After careful consideration she decided to economize by buying single, low priced machines and she explained that the trouble of winding up the machine would be the least of the instructor's troubles, as there were plenty of willing workers on the playgrounds.

Returning from the convention Edwin C. Rauth, secretary of the Koerber-Brenner Co., St. Louis; W. H. Reynolds, of the Reynolds Music House, Mobile, Ala., and Lester Burchfield, of Sanger Bros., Dallas, Tex., took a sea trip. They went from New York to New Orleans on Southern Pacific steamer "Protius" and claim that for landlubbers their sea legs worked very well. Secretary Rauth says that nearly all the men on board were initiated into the order of the "Yellow Dog" and that during the trip a very successful badger fight was pulled off, a gentleman from Canada, whose name will not be mentioned, taking the principal part—risking his life in dragging the "vicious badger" from his lair.

Mr. Rauth says that since his return business has been very good indeed—many orders for fall deliveries being on file—and that conditions seem to be improving daily.

Mr. Rauth was elected secretary of the Jobbers' National Association for the coming year and is busily engaged in getting his work lined up. Many matters of considerable importance not only to the jobbers but to the trade will call for active work on Mr. Rauth's part. His complete familiarity with the talking machine business and with selling problems in general will make him a very valuable man in the position which the association has so wisely tendered to him.

At the Silverstone Music Co. store everybody is busy preparing for the changes that are to be made during August, which already have been mentioned in The World and include a concert hall that will seat forty or more persons and will be on the ground floor and easy of access and open for auditors at all times in addition to the stated concerts for the promotion of machine and record sales. They are quite anxious to get the work done by early fall so that the exploitation of the weekly record list can be begun and the fact impressed upon the public that there are new Edison disc records each week.

A. C. Ireton, sales manager for Thos. A. Edison, Inc., was a recent visitor. He came to get acquainted and to talk over fall business,

and, of course, to write the fall order, and Mr. Silverstone talked in three and five carload shipment lots of his needs. Mr. Ireton brought the news that Story & Clark had signed for the sales of Edison disc machines in their thirteen retail piano stores and he left the \$5,000 order for the the St. Louis store with Mr. Silverstone while he was here. It so happens that there is an Edison jobber in each of the Story & Clark towns, so thirteen jobbers get a nice order each from the deal.

F. S. Hemenway, of Alexandria, La., president of the Alexandria Furniture Co., and one of the long distance customers of the Silverstone Co. for Edison discs, was a recent visitor at the store and he remained over a few days to see how retail trade is handled here. Another notable visitor was Eugene Zimmerman, president of the Peoria, Ill., Phonograph Co., Edison cylinder jobbers but Edison disc customers of the Silverstone Co. Mr. Zimmerman reports an excellent trade for the high priced machines in this thriving city.

J. E. Bennett, of Sullivan, Mo., who is selling Edison cylinder and Columbia machines in the Ozark mountain foothills, like sewing machines used to be exploited, was a recent visitor to this city. Mr. Bennett started his crews out in wagons and automobiles to test the efficiency of each vehicle. Now he has stopped the autos, as he says experience proves that the rapid travel over the country roads is too much for the talking machines and he will stick to the wagons. His business is proving very successful, he says.

J. A. Carter, of Mexico, Mo., has been installed as manager of the wholesale department of the Silverstone Music Co.

A recent Silverstone feat in the advertising line that caused considerable talk followed the use of a half page ad by a cigarette company headed: "Mr. Edison Made a Mistake." The ad was an attractive one, and, of course, referred to the inventor's recent condemnation of cigarettes. Mr. Silverstone, the next Sunday, used a half page wide space with the same sort of display line and announced "Mr. Edison Makes no Mistakes." Then his ad plunged into the fact that Mr. Edison had announced that he had put certain qualities into talking machines that previously had been overlooked and that experience had shown that he was right in his statements beyond dispute. Not a word was said about cigarettes in the ad.

THE SOUND REPRODUCTION CO.

The Sound Reproduction Co. was incorporated last week by the Secretary of State, Albany, N. Y., to engage in the manufacture of reproducing machines. The incorporators are A. Joseph Geist, H. C. Burinstein and H. W. Hess, and the capital is placed at \$5,000.

Thomas A. Edison, Inc., recently filed injunction proceedings against the Trafford Music Co., of Mason City, Ia. The Edison Co. claims that the Trafford people have removed the Edison identifications and then offered its machines for sale, in spite of the fact that the Chalmers Music Co. has sole selling rights in that city.

READY REFERENCE OF GENERAL SUPPLIES**DEALERS**

Send for our "Trial Proposition" on the Regina Hexaphone—the latest and best paying popular priced coin-operated instrument for use in public places.

THE REGINA CO.

211 Marbridge Bldg., 34th St. and Broadway, New York City
Manufacturers of Regina Music Boxes; Reginaphones;
Coin-operated Mandolin Orchestrons; Vacuum
Cleaners and other specialties.

Mermod & Co.
505 Fifth Avenue New York

Manufacturers of
Talking Machine Supplies
Motors—Sapphire Points
Diamond Points a Specialty

Keep Your Record Stock with

THE GEISE SYSTEM

Costs about \$2.00 for 250 records for 50 years
Send for 20-page catalog

THE SYRACUSE WIRE WORKS,
SYRACUSE NEW YORK

If it's in the
Victor Catalog
—We've got it



Suppose—MR. DEALER

your Distributor hasn't got it.
Suppose—you have to wait
until he sends to the factory
for it.

By the time they send it to
him and he sends it to you—
Your customer has forgotten
he ever ordered it—

You've Lost Your Customer

We Have the Largest and Most Complete
Victor Stock in the World

A Record of 99.3% Orders Filled

Send us your rush orders—*If it's in
the Victor Catalog—We've got it.*

Order now—be prepared to meet
your demand—

Don't risk losing an order.

An Order Filled Means a Satisfied Customer

THE TALKING MACHINE COMPANY
12 North Michigan Avenue : : : Chicago, Illinois

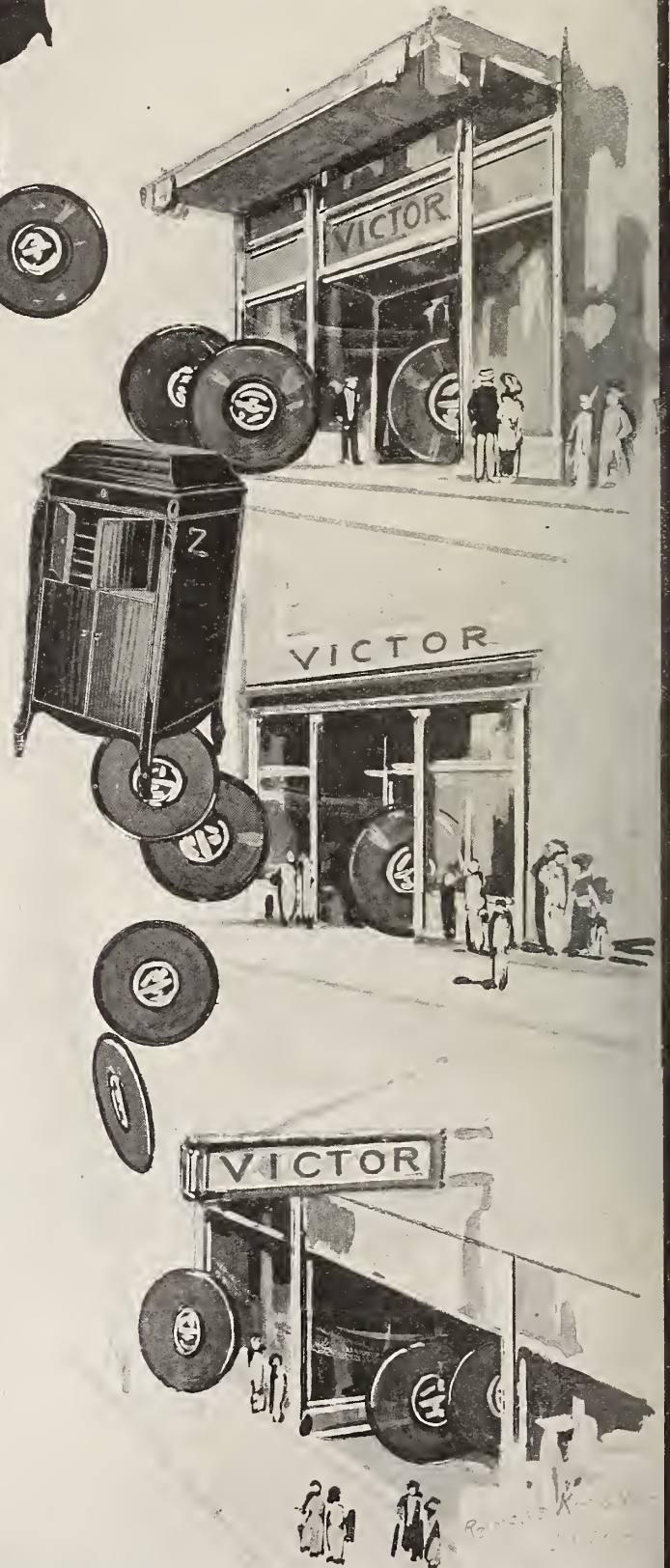

FROM OUR CHICAGO HEADQUARTERS

E. P. VAN HARLINGEN, Manager
HENRY S. KINGWILL, Associate

World Office
Consumers' Bldg., 220 South State St., Chicago
Telephone: Wabash 5774

(Special to The Talking Machine World.)

CHICAGO, ILL., August 8.—The local talking machine trade is much interested in the fate of several of its members who were so unfortunate as to be caught in the chaos caused by the European wars.

Paul Healy, president of Lyon & Healy, is lost somewhere in Europe, but whether in France, Germany or England the officials of the company have been unable to find out. A. D. Geissler, head of the Talking Machine Co., is in Europe somewhere and his exact whereabouts also are unknown. Henry Babson, of Babson Bros., and his wife are believed to be in London, but no word has been heard from him. C. E. Goodwin, head of the Phonograph Co., arrived in this country from France just in time. Had he attempted to leave two or three days later he would have found it impossible.

Miss Caldwell, of the Talking Machine Shops, is one of a party which is reported by the dailies to have arrived safely in London after suffering considerable inconveniences in getting out of France. Several dealers of Chicago and contiguous territory are also known to be in various parts of the Old World, and in almost every case it has been impossible to get in touch with them.

But little effect is expected to be shown in the coming season because of the war and any slight depression that may be resultant will, in the opinion of the local jobbers, be more than offset by the tremendous crops and general conditions that are assured us.

Talking machine men, in company with other members of the general music trade, are planning an aggressive campaign in South America during the coming year. It is generally agreed that the United States never had a better opportunity to compete with Germany and introduce our products into the great southern continent than at the present time, and if we can convince South Americans of the quality of our goods and the advantages of doing business with us, it is thought that the business can be held permanently.

One of the dailies has suggested that many of the artists who do considerable recording work may be obliged to devote their services to their various countries. Titta Ruffo, whose income as a singer is said to be almost a quarter of a million a year, may be compelled to fight for six dollars a month in the Italian army. Enrico Caruso, it

is also suggested, may be called upon to shoulder a gun. In addition to these there are a number of singers of other countries who may, because of the strict military requirements of their various countries, be compelled to join in the work of war. A local dealer deprecated the idea, saying that Italy, France and Germany appreciate these men too much to risk their loss by placing them on the firing line, although they may be called upon to serve their countries in different ways.

Talking Machine Man to Marry.

L. E. Noble, assistant manager of the wholesale talking machine department of the Wurlitzer Co., will be married September 1 to Miss Helen Jackson. The young couple will enjoy an extended honeymoon and will take up their residence on the South Side. Congratulations!

Big Wade Business in the East.

S. O. Wade, head of Wade & Wade, manufacturers of fibre needle cutters, arrived home from the convention held at Atlantic City and the trip which followed it, much pleased with the convention and the treatment received from Eastern jobbers afterward.

"The convention itself was a most interesting one," said Mr. Wade, "and in my ease the business done was more than satisfactory. I also received numerous big orders for our cutters afterward when I called upon the jobbers in various Eastern cities. We are anticipating a fine fall and do not believe that the war scare will seriously affect the talking machine trade of this country."

Demand for Filing Cabinets.

Manager Mortenson, of the Salter Manufacturing Co., reports that present indications would show one of the most prosperous fall seasons the company has ever enjoyed.

"A particularly noticeable aspect of the trade during the past month has been in the unusual demand for filing cabinets," said Mr. Mortenson. "Owners of talking machines are beginning to take a serious interest in their libraries and, with the additional fact that the average library is rapidly increasing, it is no wonder that dealers are receiving a call for record filing facilities."

Some Visiting Dealers.

Ray Bannon, of Morris, Ill.; J. Lowenstein, of Valparaiso, Ind., and Mr. Wilkinson, of the Wilkinson Piano Co., of Joliet, Ill., were visiting dealers of the week.

Stimulating Musical Interest.

A perusal of a number of newspapers from all over the country show that a very live interest is being taken in community music. There are more band concerts than ever before in the parks, and there are many concerts, free for the public, in the social centers and small park auditoriums even in the winter in the large cities. This is all of immense import to the talking machine trade, and anything that has the effect of stimulating interest in music and especially in the better class of music serves to increase the sales of pianos, player-pianos, small goods and talking machines. The interest in things musical is growing with special rapidity in the Middle West. In view of all this it is rather surprising to find that musical instrument dealers are comparatively seldom discovered doing their very best to further such plans. They should be supporters of the artistically musical in their vicinity. They should organize musical associations of various kinds and secure appearances of noted vocal and music instrumental artists. Of course there are some dealers of whom nothing can be complained in this regard, but as a matter of fact there are not near so many who realize the close connection between the arousing of musical interest and the enhancement of their business as you would expect to find. This is almost incredible, but it is absolutely true. Furthermore, it is just as true of the large centers as it is of the small cities and towns.

Move to Enlarged Store.

Tresch, Fearn & Co. are removing their business five doors south of their present location at 130 North Fifth avenue. The removal brings with it many advantages, principally in the way of space in the new quarters, which offers three times as much room as the old. Five large booths of sound-proof construction have been erected under the direction of Mr. Fearn, who has at last had an opportunity to work out his own ideas of what sound-proof construction should be. Mr. Fearn's plan embodies an air space of about two inches surrounded on either side by two thicknesses of heavily pressed felt. The felt is in turn reinforced by wood, and over the wood there is laid an attractively finished beaver board laid out in panels and trimmed in mahogany. Each booth is tastefully furnished and is large enough to accommodate three or four different styles of machines. The booths are illuminated in brilliant fashion, while the store itself is lit with large clusters of

(Continued on page 39.)

THE WADE—THE PRACTICAL—THE WADE Fibre Needle Cutter

The WADE embodies the right principle, worked out through long experience. It is simple, durable and accurate. It trims the needle at an angle resulting in the best tone. The WADE cutters are made of the best steel and are absolutely guaranteed.

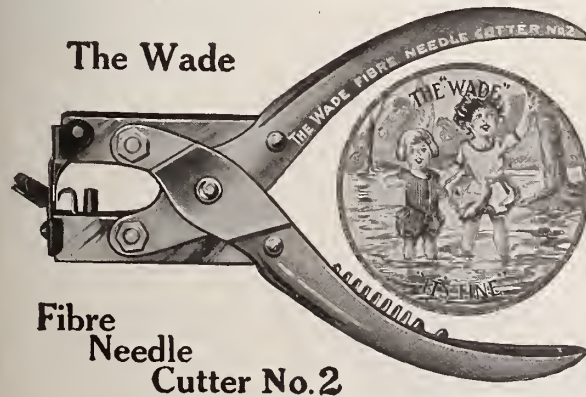

The Wade
Fibre
Needle
Cutter No. 2

The WADE is the most economical cutter. It has a self-acting stop, which prevents waste and enables one to get from 12 to 15 perfect playing points. No. 2 has a double action, making it especially easy to operate and affording the most powerful cut of any tool made. No. 1 is a very popular cutter which has given excellent service.

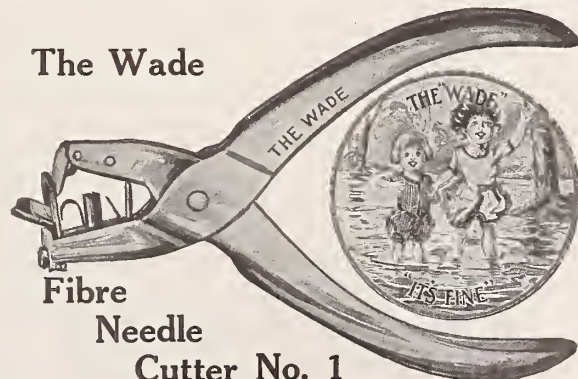

The Wade
Fibre
Needle
Cutter No. 1

RETAIL PRICES—No. 1, \$1.50; No. 2, \$2.00

Order from your regular Distributor—we sell to Jobbers only

WADE & WADE,

3807 Lake Ave.
PHONE, DOUGLAS 8108
CHICAGO, ILL.

TWO NECESSARY TALKING MACHINE ACCESSORIES

The Lyon & Healy Fibre Needle Cutter and The Dustless Record Cleaner

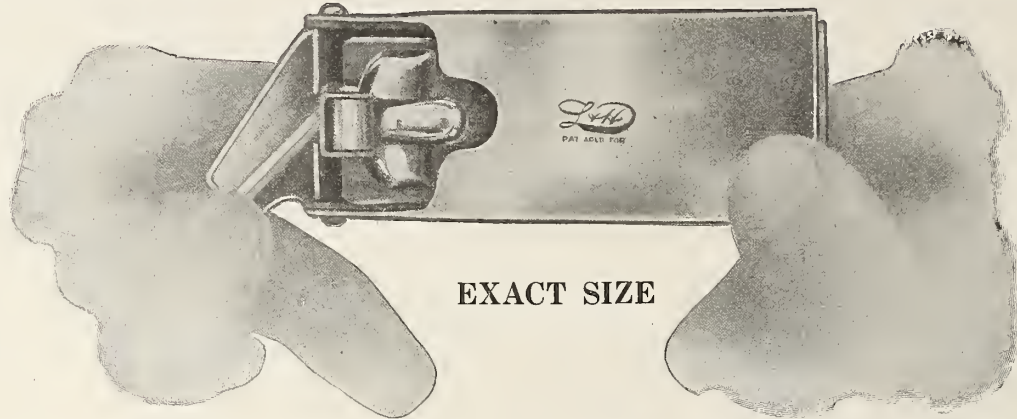

Over 50,000 Satisfied Users of the Lyon & Healy Fibre Needle Cutters!
Is not that enough to convince you that you ought not wait another minute before writing for our liberal terms of discount and a supply of the Lyon & Healy Fibre Needle Cutters?

The wonderful success of the Lyon & Healy Fibre Needle Cutter is due to the following facts:

The blades are made of the finest grade of tool steel, properly tempered; the upper blade is pivoted above and back of the cutting edge of the lower blade. It is held in place by a very high tensioned spring to insure correct leverage and a perfect point at every cutting.

The cutter is fitted with a guide that prevents the cutting away of too much of the needle and also has a receptacle that receives all the waste. It is very simple and easy to operate and, with ordinary usage, should last indefinitely without sharpening.

This cutter is invaluable to all users of the Fibre Needle, as a needle may be used twelve to fifteen times where one of the cutters is in use.

We give our absolute guarantee with every cutter sold.

RETAIL PRICE \$1.50

The everlasting Dustless Record Cleaner is an article that every Victrola owner should have.

It is made from carefully selected Wool Skin with the Wool cut short.

It polishes, cleans, prolongs the life of records and makes them look like new. Will positively not scratch the records.

RETAIL PRICE 15 CENTS



FRONT VIEW

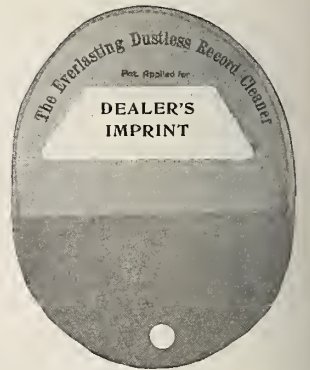

BACK VIEW

**DON'T WAIT
SEND US
YOUR ORDER
TO-DAY**

Lyon & Healy

CHICAGO

**LIBERAL
DISCOUNT
TO THE
TRADE**

FROM OUR CHICAGO HEADQUARTERS—(Continued from page 37).

SPENDS HONEYMOON TRIP ON STREET CAR.**Columbia Grafonola Furnishes Music for a Novel Stunt in the Matter of Up-to-Date After Marriage Celebration Which Has Won Much Notice for All Concerned.**

(Special to The Talking Machine World.)

CHICAGO, ILL., August 11.—When George E. Stoddard, author and playwright, wrote the book of "The Elopers" he did not realize that in a short time he, too, would be eloping. Certainly he did not realize that his honeymoon trip would be made in a street car, with his friends dancing the tango and hesitation to the music of a talking machine. But so it was.

Shortly after the first performance, Mr. Stoddard met a very pretty member of the chorus, who appealed to him as no other woman ever had.

phone Co., had been invited to be present and furnish the music. They did so with the aid of a Columbia "Favorite" Grafonola and a few Columbia records, such as "Puppchen" and "Dreaming." A half dozen of the company could dance quite comfortably at a time, and in the accompanying picture we see two of the leading women, Miss Sylvia De Frankie (on the left) and Miss Olga De Baugh (on the right) dancing with the two comedians, Mr. Dunlay and Mr. Kelso, respectively. Miss Kennedy is seated at the left of the picture.

The "Herald Movies" man discovered the party

powerful electric lights. These lights, because of the construction of the bulb and the fact that it is filled with a gas, furnishes a soft, very brilliant flood of light. A large basement is a part of the new establishment, and in it there will be located a commodious salesroom and a large space for the storage of records. Mr. Fearn promises that the system of record storage and filing will be the last word in that direction. Tresch, Fearn & Co. are one of the few dealers in Chicago who handle the Victor, Edison and Columbia lines.

Brings Out New Record Cabinet.

James I. Lyons, Chicago's pioneer talking machine dealer, has designed and is putting on the market a cabinet that is especially fitted to the storage of Edison Amberol records. The cabinet is finished in various woods and contains five drawers, each capable of holding thirty-six cylinder records in their boxes. Provision is made for setting an Edison machine upon the top of the cabinet, and as the cylinders are placed in the drawer with the titles on the boxes facing upward, it is but the work of a second to select the record desired. Mr. Lyons is receiving numerous inquiries regarding this much needed cabinet.

Personals and Visitors.

Miss Mary M. Cockrell, of the Talking Machine Shops, is on a two weeks trip to Niagara Falls.

Manager Cullom, of the talking machine department of the W. W. Kimball Co., has returned from a vacation at Roscommon, Mich.

John Greene, buyer of the Victrola department of the Young & Chaffee Co., of Grand Rapids, Mich., was a visitor to the office of the Talking Machine Co.

Mr. Brodt, of Stewart Bros., Columbus, O., was also a visitor to the local trade. He reported a satisfactory business and said that considerable trade was attracted to the store following a novel demonstration of the new dances that were presented in the show windows of the establishment. Some of the juvenile pupils of a local academy were secured who were glad to furnish their services at a reasonable cost.

Among a number of other prominent dealers who visited the Great Central Market recently were George H. Mee, of Faribault, Minn.; Mr. Siegler, of Foster's Picture Shop, Lafayette, Ind., and R. M. Rhodes, president of the Rhodes Furniture Co., of Memphis, Tenn.

R. A. Seager, manager of the Victrola department of Scruggs, Vandervoort & Barney, St. Louis, Mo., was a visitor to the local trade.

E. A. Moore, in charge of the piano and Victrola department of the Pelletier Co., Sioux City, Ia., was a visitor to Chicago recently.

A. G. Kunde, Milwaukee Columbia representative, was in Chicago for a short stay a few days ago.

R. L. Du Bois, assistant manager of The Phonograph Co., left shortly after the return of C. E. Goodwin on a two weeks trip to Green Bay, Wis.

F. A. Copeland, Edison dealer of Elgin, Ill., was a visitor to the offices of the Phonograph Co., as was also Charles Dahlen, of St. Charles, Ill.

A visiting Edison dealer of Chesterton, Ind., was J. B. Lundberg.

W. F. Standke, New Orleans manager of the Columbia Graphophone Co., visited the city recently. Mr. Standke reported that business in the Southern States was very good, with every prospect for a record-breaking fall.

Honeymooners Visit Us.

B. M. Buck and his bride, of Lansing, Mich., were visitors to Chicago recently. The Newlyweds were entertained by G. P. Ellis, of the Talking Machine Co., who informed us confidentially that while here the groom displayed much interest in the lady ice skaters at the College Inn, which almost caused a family row.

Open New Department.

C. I. Abelowitz has been appointed manager of the new Victrola department of A. Herg, Terre Haute, Ind., which concern operates the largest department store in that city. Mr. Abelowitz was in Chicago recently for the purpose of placing his initial order with the Talking Machine Co., and announced that he was opening a first class de-

**Dancing the Tango to Columbia Music on Street Car.**

He proposed and was accepted, but his endeavors to keep the news from the other members of the company did not meet with success, and Miss Frances Kennedy, singing comedienne and star of the show, invited the newly weds to a mysterious party to be given at Thirty-ninth street and Cottage Grove avenue, where the blushing bride and groom found Miss Kennedy and the other members of the company awaiting them at the car barns. The completed assemblage was hustled into a private Cottage Grove avenue car and the honeymoon was begun.

W. W. Parsons, local manager of the Dictaphone Co., and Mr. Winter, of the Columbia Grapho-

partment, equipped with new booths and furnished in the latest fashion. The opening of the department was set for the early part of this month.

Prophecies Big Fall Business.

W. C. Fuhri, district manager of the Columbia Graphophone Co., returned a short time ago from an enjoyable vacation spent at Pine Lake, Mich. Mr. Fuhri returned to find reports coming from all sections of the Middle West, indicating that this fall is to be a most favorable one to the talking machine trade.

C. F. Baer, local Columbia manager, also was most optimistic about prospects for the coming season, and upon returning from a trip through Iowa, said to The World: "Crops are in excellent shape in every part that I visited. Factories are starting up and business will be in full blast by early fall. Railroad companies are loosening up in their expenditures, and some of them are pushing construction and development work hard. From the present outlook I think that the coming fall will be a big one for us."

Mr. Baer added that while the war in Europe would injure this country greatly in some respects, it would also be the means of opening up old factories and perhaps permanently reviving some of

shortly after it started and took pictures of this remarkable elopement, which were later shown through the medium of the movie shows to over half a million people of Chicago. We are indebted to the "Herald Movies" for this clipping from their film.

Mr. Parsons and Mr. Winters are to be congratulated upon getting in on this, for they secured for their company some very desirable publicity and enjoyed a very pleasant time themselves.

"We experienced no trouble in operating the machine," said Mr. Parsons, "for the roadbed was good and, though the car swayed considerably at times, the 'Favorite' worked to perfection."

the industries that suffered from the reduced tariff.

Satisfactory L. & H. Business.

L. C. Wiswell, manager of the talking machine department of Lyon & Healy, tells The World that while business was quiet, as is the custom at this time of year, the month of July showed a very satisfactory business both in the wholesale and retail departments over the corresponding months of last year. Mr. Wiswell was greatly pleased with the convention held at Atlantic City, and spoke very highly of the entertainment given by the Victor Co. to the visiting jobbers.

Mr. Wiswell leaves shortly on a cruise through the Great Lakes, and will go as far as Buffalo. He will be accompanied by his wife and four children.

Almost all of the Lyon & Healy travelers are returning from their various vacations. E. P. Bliss, the Michigan traveler, returning from a trip to Jamaica; H. R. Smith, the Illinois traveler, returning from two weeks in the Catskills, where he said he discovered the man who paid the rent for Mrs. Rip Van Winkle, and J. B. Ryde, returning from Michigan. W. P. Roach, who handles

(Continued on page 40.)

FROM OUR CHICAGO HEADQUARTERS—(Continued from page 39).

the Chicago business, enjoyed a vacation in Iowa. **Victor Lecturer Here.**

L. C. Case, lecturer of the educational department of the Victor Talking Machine Co., spent the past two weeks in Chicago. Mr. Case was busily engaged while here in demonstrating the educational value and instructive possibilities in all phases of musical work to a large number of summer school classes.

Roy J. Keith Had Great Vacation.

Bronzed with the sun and wind and looking the picture of good health, Roy J. Keith, sales manager of the Talking Machine Co., returned this week from what he characterized as the "best vacation I have ever had." And judging from the photographs that he brought back with him, it must have been a most enjoyable outing.

"We were away up on the northern—the Cana-



Keith with Prizes of Vacation.

dian—shore of Lake Superior, up where almost the only people that we saw were a few Indians and traders. Arriving at Michipicoten, four of us chartered a fishing tug which carried us to Michipicoten Island. Here we unpacked our outfits, and after enjoying the island for a while paddled to the shore of Superior, some twenty miles in. From this point we slowly worked our way back to Michipicoten, 125 miles away, fishing at the mouths of six rivers. We were in two canoes and did most of our paddling at night, when the breeze had died down. We hugged the shore pretty closely, for at times we ran into rough weather and on a few occasions we were unable to put out at all. We had some excellent luck fishing and caught some brook trout, such as those shown in the picture, that fairly melted in our mouths. This particular string averaged two pounds."

Western Pathéscope Business Increasing.

Francis Reno, Chicago representative of the Pathéscope Sales Co., 1306 Marquette building, reports to The World that the Continental wars will not interfere in the slightest with the conduct of their business and the supplying of dealers with stock. "We have very large stocks of both machines and films in this country," said Mr. Reno, "more than sufficient, I believe, to last us through the war. Films are manufactured by women in the big factory near Paris, and they have not been obliged to leave their work. Present indications are that steamships will be running again soon between France and this country, and this of

course brings matters back to normal. We are doing a very good business with talking machine dealers in this section, and already a large number of those who have taken on the line are coming back with reorders. The talking machine dealer is peculiarly adapted to handle our line and is rapidly finding it out."

Mr. Reno showed the Pathéscope and its uses to an admiring attendance at the recent Downers Grove (Ill.) Chautauqua. M. M. Blackman, of the talking machine department of Lyon & Healy, made the arrangements with Mr. Reno.

Talking Machine Travelers Return.

Traveling salesmen of the Talking Machine Co., of Chicago, are now, with one or two exceptions, back from their various outings. George Cheatle, traveling sales manager, and his wife, spent some time on a ranch at Folsom, Cal. Mr. Cheatle has once more resumed his travels on the sunny coast. D. C. Preston, Wisconsin traveler, and his bride have returned from a month's vacation spent at Clear Lake, Ia. E. L. Barker enjoyed his summer's rest at a Michigan summer resort. Mr. Barker travels in Illinois and Indiana. H. L. Flentye, city salesman, is at present at the sanitarium at Battle Creek, Mich., recovering from an illness that unfortunately attacked him just as he started on his vacation.

L. C. Parker, manager of the piano department of Gimbel Bros., is reported here to have left for Sturgeon Bay, Wis., where his father is ill.

Up in the Air.

The accompanying photograph shows the members of the Victrola department of the Stewart Dry Goods Co., of Louisville, Ky., as they were snapped while on the roof of the company's establishment one day not very long ago. The photograph shows only nine people, but in the busy months the force is increased to about fifteen. The department is under the management of L. M. Knickerbocker, who has at his disposal an excellent salesroom and a large record room. The salesroom is fitted with five sound-proof booths constructed of reinforced plate glass. The depart-



Members of Victrola Department Stewart Dry Goods Co.

ment was opened in June, 1913, and with the force of five people, was G. P. Ellis, who is now connected with the Talking Machine Co., Victor jobbers of Chicago. The department was successful from the first, Mr. Ellis instituting ideas which were the cause of an increased business from their

inception. Under the management of Mr. Knickerbocker the department has continued to expand, and at the present rate the coming fall season will necessitate a force much larger than the company has been obliged to use before.

"Summer Sales Ideas."

That is the title of a most efficient little symposium of ideas for the creation of summer sales that has been issued by the Talking Machine Co. under the direction of Sales Manager Roy J. Keith.

The booklet is made up of nine sheets, each sheet bringing out in detail some method of approaching prospective customers that can be well handled during the summer season. Typical letters are suggested, as well as supplementary and follow-up matter. The possibilities of hotels and summer resorts are particularly dwelt upon and methods for presenting demonstration dancing exhibitions are explained.

Big Chicago Industries Rumored.

There are numerous rumors in the trade that refuse to be downed anent the establishment in Chicago of two large factories for the production of talking machines. Both are said to be backed financially by large Western corporations who see big opportunities for handsome returns on some idle capital in this business. It is also stated on good authority that a plant for the manufacture of records is soon to be established here and that the machinery to be used in a new process of record making is already contracted for.

CONDITIONS IN CUBA

Are Generally Satisfactory, Says E. E. Robinson of the Export Department of the Columbia Co.—Robins & Co.'s Good Business.

E. E. Robinson, the well-known globe-trotting representative of the export department of the Columbia Graphophone Co., returned to New York this week after a month's trip to Cuba. Mr. Robinson was accompanied on this trip by Clyde Emerson, of the Columbia record laboratories, and a veteran of the talking machine industry:

"Business conditions in Cuba are generally satisfactory in view of the unsettled state of affairs throughout the world," said Mr. Robinson in a chat with The Review. "The sugar crop was unusually good, but the decline of the tobacco crop proved a disappointment to business men in Cuba. The outlook is encouraging, however, in practically all lines of business.

"Our representatives in Cuba, Frank G. Robins & Co., are closing an excellent business, both in machines and records. Their progressive and energetic sales methods and extensive advertising campaign are well calculated to produce far-reaching results. While in Cuba on this trip we secured quite a number of records by well-known artists and prominent orchestras."



The Columbia automatic stop. The most accurate automatic stop made and the easiest to operate.

Gun Metal, \$2.00 list. Nickel Plated, \$2.50 list. Gold Plated, \$3.00 list.

May be adjusted to both Columbia and Victor disc machines. Order from any Columbia Distributor.

TERRITORIAL LINES FOR JOBBER AND DEALER.

An Interesting Presentation of an Important Subject by H. H. Blish, Secretary and Treasurer of Harger & Blish of Des Moines, Ia., and President of the Edison Disc Jobbers' Association—His Viewpoint of This Situation Is Both Helpful and Timely.

One of the greatest handicaps that the jobber has been working under in the past, in the mind of the writer, has been the difficulty in engaging the attention of firms of recognized standing as to the permanency of the proposition and the stability of the line. They point out, and with justice too, that anybody who can scrape up enough to buy three machines and 100 records can get into the game, only to find later on that

to spend whatever sum in reason, was necessary to get results. They want to feel that their investment is stable and that the risks now being run by reason of the kind of competition with which they have to contend, is done away with.

The jobbers territory should be prescribed in the same way, by placing a jobber in complete control of all the business within a prescribed field. He being on the ground, is in a far better posi-

local jobber or get out of the business, will see to it that his standing on the books is all that the credit man desires. The jobber, when he lines up the right sort of representation in his field, can afford to extend every bit of help financially within the range of his ability, as well as with the help that his salesmen can render, without feeling that just as soon as he has developed a customer worth while, he loses him to some other jobber through the personality, possibly, of some first-class salesman, and all of his days and nights spent in developing that dealer is lost.

If a jobber in automobiles wants to buy Ford cars, there is only one place to go. Same way for the jobber in buying Edison machines. Why not the same condition for the dealer. You may argue

that it doesn't seem fair or good business to ask a dealer to buy of a jobber if the service rendered is inadequate or if possibly the jobber may, at the time, be temporarily out of the goods desired. In this regard, I would put it up to the next nearest jobber to fill the order immediately, charging the jobber from whose territory the order came, the dealer's discount. He thereby secures the profit that he is entitled to by reason of his having the goods, and the jobber who first secured the order is penalized the profit by reason of his failure to supply the order promptly, and in addition carries the account. This, he should prefer doing, for it prevents a good customer from getting on another jobber's books, and keeps the credit standing of the dealer wholly within his hands.

To sum up, I would say that there are altogether too many small stocks

in the field and we can never interest capital to the extent that we should, until they can be given a definite and defined territory to work in, and be made to feel that in due time all the results of their efforts will revert to them and to them alone.

PARLOR PROVES ATTRACTION.

J. E. Crayton & Co., of Charlotte, N. C., who recently added to their line the new Edison diamond disc phonograph, have found it necessary to install a handsome parlor or hall for the entertainment of the music lovers of that city. It is proving a very popular attraction.

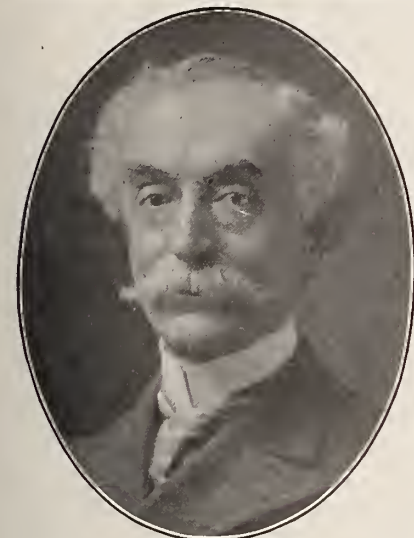

B. M. Harger, President.



Geo. C. Silzer, Vice-President.

Officers of the House of Harger & Blish, Des Moines, and Sioux City, Iowa, the enterprising Edison jobbers, whose business was founded in 1887, and incorporated in 1904.



H. H. Blish, Secretary and Treasurer.

the same degree of salesmanship must be used to dispose of them as is required of any other line of merchandise. The dealer by reason of his incompetency, loses interest and wants his money, which, more times than otherwise leads to price cutting on the side, and in doing so, completely discourages the good dealer who has spent freely of his time and money in placing the proposition on a safe and sane basis. In arguing the question recently with a large dealer who was spending in advertising, a large percentage of his earnings from that department, said "what inducement is there in it for me to carry the amount of money that I have in these goods and to continue doing so, working by day in demonstration at the store, and by night in the lodge, school room or home, only to find that by my activity, later on, I have excited the envy and cupidity of some competitor, who finds the field that I have been engaged in tilling, looking so good that when I should be harvesting the results of my labor, he steps in with an inconsequential purchase of three machines and shares with me the results of my effort." There is no question but that there is little incentive to first-class dealers carrying complete stocks unless this protection is afforded them.

I have, for a long time, advocated definite and positive territorial lines for both jobber and dealer as the best solution of this question. While this need not involve necessarily an exclusive sale proposition in the literal sense, he can be given to understand that no solicitation for business will be tolerated in his prescribed field. I would go even further than this and require that any dealer receiving an order from outside the territory allotted to him, should be required to split with the dealer from whose territory the order came. The Vose Piano Co., of Boston, has been working this plan for years, to the entire satisfaction of all concerned. The automobile industry absolutely prohibits a sale in outside territory under penalty of forfeiture of contract. While right in the family we have a precedent in the dictating machine department requiring all work done strictly within territorial lines. The carrying out of such a proposition would tend greatly to lessen the number of dealers and jobbers but would get men into the business who would feel justified in carrying large stocks and would stand ready and willing

tion than anyone else to decide as to the desirability of an applicant. By holding the jobber to a strict account of his territory for development, it is up to that jobber to either improve it or relinquish that field. Most important of all is the question of credits which would be entirely solved were territorial lines placed around the jobber, and, in this, the factory is as much a beneficiary as is the jobber.

We all know of the kind of trade that gets in to the limit with one jobber, then tries jobber number two and three, until each have credit tied up exceeding many times the dealer's ability to pay—then a settlement of 30 or 40 cents on the dollar. A dealer knowing that he must pay his

LONG CABINETS

HAVE MANY FRIENDS



A splendid line of well made, elegantly finished, Record and Player Roll Cabinets.

Prices and printed matter for the asking.

Kindly anticipate your requirements for Fall, naming dates for shipments.

The Geo. A. Long Cabinet Co.
Hanover, Pa.

Address **Clement Beecroft, Sales Manager**
309 W. Susquehanna Avenue, Philadelphia

D65, D66, D67.
FOR VI., VIII., and IX. VICTROLAS.
Mahogany, Fumed Oak, G. O. and W. O.



The dealer who carries Columbia product knows that he has one grade of quality all the time: also he has the comforting knowledge that the range of prices gives him something to match up with every variety of pocket that is brought into his store.



(Write for "Music Money," a book "full of meat" for those dealers interested in quick and frequent turnover of capital.)

**Columbia Graphophone Company
Woolworth Building, New York**

NEW QUARTERS IN DALLAS, TEX.

Southwestern Talking Machine Co. Occupying Handsome Home in Heart of Retail District.

Upon the occasion of his recent visit to the New York headquarters of the Columbia Graphophone Co. last month, Rafael Cabanas, president of the Mexican Phonograph Co., Genl. Mexico City, Mex., and the Southwestern Talking Ma-

chine Co., Dallas and El Paso, Texas, both exclusive Columbia distributors, gave an interesting account of the new home that the latter is now occupying in Dallas, its headquarters. Situated at 1011 Elm street, this new building is in the heart of the retail piano and talking machine district, and easily accessible to the best class of retail trade. The building runs clear back to Pacific street, where a railroad siding at the door

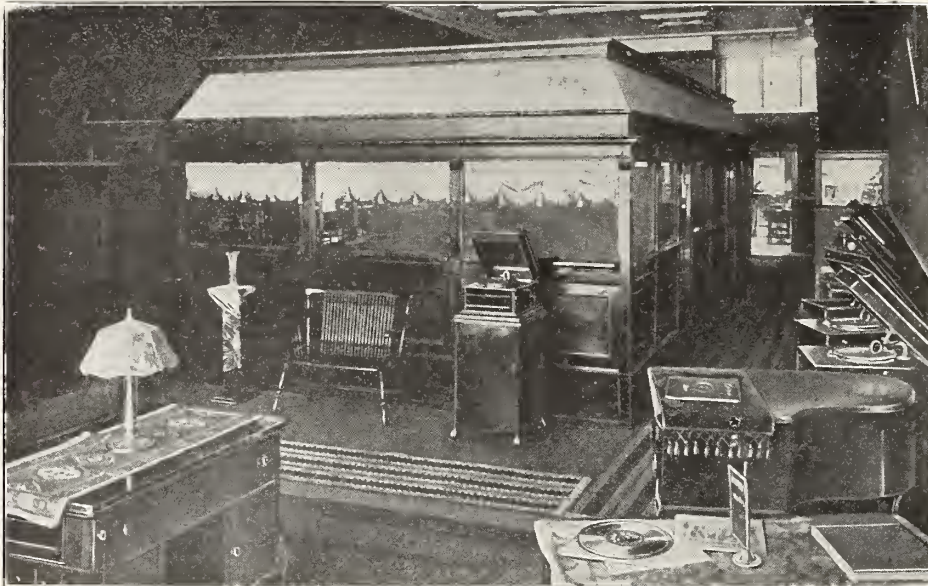

New Warerooms of the Southwestern Talking Machine Co., Dallas, Tex.

gives maximum shipping and freight efficiency. Before taking possession, the company constructed an entirely new exterior and interior, and as it now stands, the building is one of the show places of the Dallas retail district. There are three handsomely furnished demonstration booths on the main floor of the warerooms, and the walls are finished in green and gold with the ceiling in ivory and bur-lap wainscoting. The indirect system of lighting adds to the dignified appearance of the warerooms.

The new warerooms of the Southwestern Talking Machine Co. have been visited by many of the city's prominent artists, while the auditorium has already been the scene of several excellent concerts given by successful local clubs and societies. R. R. Souders is the capable manager of this company, while A. B. Giles, who directs the publicity and advertising has been an important factor in the company's pronounced success.

DEMONSTRATED EDISON DISC RECORD

(Special to The Talking Machine World.)

TOPEKA, KAN., August 4.—The Santa Fe Watch Co., Edison disc representative in this city, recently gave an unusual and successful demonstration of the Edison disc product before the Topeka Cooking School. A formal program of representative disc selections was arranged for the occasion, and at its close additional records were played for the edification of the audience, which was delighted with the tonal beauties of the Edison disc machine and records.

VICTROLA WITH THE ORGAN.

Charles H. Demorest gave a novel program on the organ in Tally's Broadway Theater in Los Angeles, recently in which the Victrola was used with organ accompaniment in Leoncavallo's arioso from "I Pagliacci," sung by Caruso, and in John McCormack's singing of Marshall's "I Hear You Calling Me."

PHILADELPHIANS ON THE SEA.

Talking Machine Men from Snellenberg & Co. the Guests of E. G. Evans, of C. Bruno & Son, Inc., on a Fishing Trip Outside Sandy Hook—Some Happenings of Interest.

R. B. Cope, E. W. Eisenhart, W. C. Stiver, Jr., and Wm. S. Irwin, of the talking machine department of N. Snellenberg & Co., Philadelphia, motored to New York recently, where they were the guests of E. G. Evans, of C. Bruno & Son, Inc., 353 Fourth avenue, New York, the musical merchandise jobbers.

With his usual hospitality, Mr. Evans invited the party to a fishing trip on his motor yacht, and with a "properly loaded" boat the party struck the sea just outside of Sandy Hook. A fair sea was running, so the story goes, and the semi-circular rail stunts of Bro. Cope would do justice to any acrobat of Barnum's circus, reliability and speed being the chief points of merit. But the other members were pulling in sea bass and fluke by the (thousands, hundreds)—take your choice as you read—in any event, totaling a very good score. Evans, it seems, has a special map of the fishing grounds.

The party got back to the landing successfully, and about 12 o'clock at night started to motor back to Philadelphia. In an hour they were caught by the big thunder and lightning storm, but this time they toured through the water without the use of "Mothersills."

INCORPORATED.

The Hutz Automatic Phonograph Co., of Brooklyn, N. Y., was incorporated this week with a capital stock of \$25,000 for the purpose of manufacturing and retailing musical instruments. Those interested are M. and H. Hutz, and H. T. Reeb.

AN ESSENTIAL HOME REQUISITE

Is the Dome Record Case Made by W. D. Andrews of Buffalo—Popular with Users.

One of the strong selling specialties in the talking machine trade is the Dome Record Case made by W. D. Andrews, Buffalo, N. Y. This case holds 20 records, accessible for instant use, and by following the index the owner can find just where each record is. Built strongly, with a nickel-plated metal support to keep records in position, its durability is unquestioned. Another feature is its lock, which enables the owner of a machine to keep valuable records from promiscuous use. Furnished in ten and twelve-inch record sizes.

As the trade knows, W. H. Andrews is a Victor jobber who prides himself upon his good service, not only from the stock standpoint but for facilities. He has thirteen lines of railroads and five express companies assisting him, as well as boat lines on the Great Lakes. One of his specialties is furnishing records in Dome Record Cases.

**PHONOGRAPHISCHE
ZEITSCHRIFT
BERLIN C. 19, GERMANY**

The oldest and most up-to-date trade paper covering the talking machine line published in the German Language.

PUBLISHED WEEKLY. FOUNDED 1900

Circulates all over the world.

SPECIAL EXPORT NUMBERS appear in four different languages at regular intervals.

Subscriptions for this talking machine publication 10 Marks yearly. Sample copies sent free.

FROM OUR EUROPEAN HEADQUARTERS

2 GRESHAM BUILDING, BASINGHALL STREET E. C., LONDON, W. LIONEL STURDY, MANAGER.

Slack Season in the Gramophone Trade—War on the Continent Causes Concern—Unprofitable Trading in the Wholesale Field Brings About Chaotic Conditions—Co-operation Among Manufacturers Necessary—Performing Rights Society Has Its Troubles—German Manufacturers Revise Agreement—New Gramophone Introduced—Interesting Lists of Records Issued—His Master's Voice Co. Publicity—Larger Quarters for Reynolds—New Models for Blum Models—The Trade Situation in Germany—News of the Month.

(Special to The Talking Machine World.)

LONDON, E. C., August 6.—General business returns published recently go to show that the slack period is upon us, and it is not therefore surprising to receive adverse reports concerning gramophone trade conditions from even the chief centers of industry. Home affairs are quite satisfactory if one excepts the tendency of the Irish Home Rule impasse to disorganize trade, but the foreign outlook at the moment of writing is naturally causing some little concern to all seriously minded men. What the position will be when these lines appear in print one would be foolish to predict. The European situation is, nevertheless, by no means reassuring, though it is generally felt that things will so far adjust themselves as to dispel the war clouds which now darken the horizon.

In the retail field trade is not over healthy. Reports indicate that fair sales are resulting from the featuring of portable hornless instruments, but little trade is being done in other models. Manufacturers and wholesale houses are, however, quite busy in booking orders from dealers for the coming season's new models and quite a number of firms have already established stock rooms in the large towns. The activity is as yet mainly confined to travellers and the result of their efforts will be early apparent in increase of staffs and general speeding-up at the various factories.

A brief survey of the gramophone trade situation is, however, of unsatisfactory prospect from the viewpoint of its present internal chaotic state. Those who follow the trend of events foretell something in the nature of an upheaval within the near future. On the existing basis of unprofitable trading, in which not a few firms are unhappily engaged, matters cannot continue indefinitely. Since last September when the cheap record war commenced, the situation has developed perceptively in the only direction one could reasonably anticipate. The commercially unsound nature of this class of trade, quite apart from its destructive effect on the sales of higher-priced products, has, unfortunately, compelled three or four firms already to seek sanctuary in Carey street, the destination of all involved within the meshes of financial difficulty, or otherwise to seek oblivion by choice rather than jeopardize their credit. Party from necessity and other reasons arising from the effects of lowered record rates, the probability is that two or three more firms will close down before the season commences. Competition has its limits, although such an outcome is perhaps more the result of the price-war than competitive conditions, keen as they, undoubtedly, are. Again, the grouping of several continental manufacturers will exert a big influence on British record trade this season. Certain forces are at work across the channel, and it is known that preparations for a stronger onslaught on this market must soon crystallize into activity. In this regard some interesting announcements may shortly be expected.

Meantime, the worst attributes of sordid commerce continue to exercise sway, and handicapped by these elements of retardation the gramophone trade has to work out its salvation. Progress may be, in fact is, slow, for it is the lack of understanding, the setting up of false pride and the encouragement of isolated action that obscures the

light of common sense, and temporarily, at least, holds up that which must eventually develop from the present chaotic state—co-operation among manufacturers for the mutual protection of general interests, among which the most important is the regulation of prices. The trade must, ultimately, emerge triumphant, but far better an immediate reorganization of existing forces than a continuance of this financially exhausting and commercially detrimental policy.

Comments on Judicial Decision.

The subjoined comments on the judicial decision in the recent copyright case between Chappell & Co., Ltd., music publishers, etc., and the Columbia Graphophone Co., are from the Author newspaper, and will be perused with much interest:

"We do not claim to know the motives of Chappell & Co. in taking this action, but the effect of the judgment delivered will not, so far as we can see, be to help composers who are anxious that their works should be reproduced mechanically.

"In effect it amounts to this, that a composer may assign his mechanical instrument rights to the publisher, who may, if he chooses, make it almost impossible for the mechanical instrument trade to take up the work.

"The publisher—if the composer foolishly allows him to hold the copyright—has only to refuse to allow the reproducer to make the manuscript orchestral accompaniment which is necessary for the manufacture of the record.

"We believe that Chappell & Co. are now engaged in the manufacture and sale of contrivances for the mechanical reproduction of music, and if they have succeeded by this action in abolishing the competition of their rival, we hope that composers will be wise enough to see that they get for the transfer of their rights to Messrs. Chappell something much more substantial than the fees laid down in the act. These fees were fixed by the legislature as representing what—rightly or wrongly, we think wrongly—was regarded as a fair return from the mechanical instrument trade for the use of the composer's work. It must be remembered, however, that they were not fixed as a fair return for the exclusive use by any one firm."

The New Disc Recorder.

The new disc recorder which has been marketed here under the title of the Plantor Home Recorder is meeting with a phenomenal success, due as much to its simplicity as to the provision of flexible cardboard discs having a fine wax surface whereon to record, thereby eliminating the need of expensive blanks and shaving apparatus. The discs will take up to about one thousand words, and their cost is but 2s. 6d. per dozen. Leading wholesale houses now stock the Plantor device, and great interest is evinced in it by the trade generally.

Another Copyright Suit.

Another summons under the copyright act was heard at a London police court recently when Ray Duskwick, a gramophone dealer of Wardour street, London, had to answer to having unlawfully sold an infringing copy of "Across the Meadows," a work in which copyright exists. Evidence having been given by the composer, Percy S. Robinson, and Boosey & Co. that neither had given authority for a gramophone record to be taken of the work in question, defendant disclaimed knowledge that she was breaking the law, as she bought the records from a wholesale dealer in the ordinary way of business. The London agent of the Turmaline Record Co., Berlin, the makers of the record, said about last March he engaged Mr. Robinson to play this particular dance, and paid him for so doing. He understood that permission to make a record was then given. Royalty stamps had been purchased from Messrs. Boosey, but there was no stamp on the record in question. The magistrate imposed a penalty of 40s. with 10 guineas costs.

German Decision Upset.

After practically declaring the Eufon patent on hornless machines void, the German patent officials have had their decision upset by the German High Court. According to a contemporary the patent is of great importance.

Performing Rights Society Meets Opposition.

The recently established Performing Rights Society, of which I wrote last month, is meeting with considerable opposition from a number of influential publishers and composers, who take the view that as the popularity of their works is often dependent to a large extent upon their frequent performance all over the country, they should not attempt to place restrictions upon artists desirous of singing or playing the work.

It is further argued that as a form of advertisement the composer receives full value by means of royalties payable on sales, and to place a premium on this freely given publicity is obviously contrary to business ethics. The situation would seem to call for co-operation among artists with a view to the protection of their interests. I have received intimation from several large publishers condemning the incidence of this society and its objects, with the further advice that no charge will be made for the performance of any works they control. Some very interesting views upon this much debated society are given by eminent publishers and composers in a leading London newspaper which has devoted several columns to this purpose. The gist of the correspondence would seem to indicate that great divergence of opinion prevails in musical circles regarding the wisdom of charging artists for the public performance of copyright works. Comparison, too, is drawn between conditions in this country and particularly the continent, where sheet music sales are but a fraction of those in the United Kingdom. It is argued that the Performing Rights Society's legal right to make a charge for performance is quite outweighed by the publisher's (or composer's) dependence upon prominent artists to popularize works which in the majority of cases would otherwise not attain commercial value. It is surely against sound business principals, but opinion prevails in responsible quarters that the society will eventually win the battle now in operation.

Revision of German Convention Agreement.

As from July 1st when the convention came into force officially, dealers who have not or do not sign the agreement will be refused supplies of records made by convention manufacturers or sold wholesale by those factors who are signatory to the convention terms. A considerable body of retailers dissent from the principle of the scheme altogether, but for protective reasons have been persuaded to sign the agreement. Others of more independent spirit carry their opposition so far as an absolute refusal to participate in what they term a trust. Whether or not there is reasonable ground for this attitude time alone can determine, but the fact remains, rightly or wrongly, that many look upon the convention with great misgiving. Owing to the distrust and opposition which the manufacturers' proposals met with in retail circles, it became necessary to embody some important changes in the first agreement ratified by the convention. For instance the various German dealer's associations demanded the right and freedom to continue the sale of Pathé discs notwithstanding that Pathé Freres remain out of the convention. Permission to sell these records was therefore given to convention factors and dealers until July 1, 1915, providing that they maintain list prices. The time for disposal of stocks of non-convention records is extended from October to December 31, but no modification of the original arrangement regarding exchanges of worn-out records can be made. On the question of sell-

(Continued on page 44.)

FROM OUR LONDON HEADQUARTERS—(Continued from page 43).

ing records to the staff of convention firms, it is expressly laid down that manufacturers must not extend this usual privilege except in the month of December. The limit is twenty-five records, and this only on the understanding that such records bearing a "not for sale" label are for the purchasers' own use or for Xmas presents. It is further agreed that all fines for breaches of the convention agreement shall be disposed of by the German Talking Machine Dealers' Association, and after making other provision for arbitration in disputes, etc., the document embodying the foregoing modifications of the original proposals closes with a plea for co-operation on the part of the dealers' own society.

Various opinions obtained and published by the Phonographische Zeitschrift lead to the belief that among manufacturers at any rate the convention scheme finds favor.

On the retail sign the modified agreement it is said has met with the practical support and approval of about three-fifths of the trade. The final success of this German convention scheme has, naturally, awakened great interest among British gramophone traders, but so far the example has not materially encouraged our manufacturers to do likewise. There has been some talk about it, and in theory the convention plan is approved—for Germany!—but the time is considered inexpedient for any like attempt to be made in London.

New Gramophone Submitted.

A first model of an entirely new gramophone of the interior horn, or so-called hornless type, was recently submitted to my inspection, and a brief description of it will, I think, appeal to all those having the interests and progress of the gramophone industry at heart. It is the invention of W. D. Sternberg, of 19 City Road, London, and is well-named the "Sterno-phone." In outward appearance it very closely resembles that of an ordinary hornless instrument. One realizes the comparative difference upon examination. There is no open front or horn, the sound-amplifying chamber being situated at the back. Delivered

direct from the tone-arm into this chamber the sound passes upward and is deflected from the lid which acts as a sound-board. The tone is thus evenly distributed at the right angle in all directions. But perhaps the most ingenious feature of interest is an interior device by means of which the trouble of starting and stopping the instrument is embodied in one action. Pending acceptance of patents I am unable to describe this equipment in detail, saving what it accomplishes. To play a record one has only to insert the needle, the rest is done automatically by simply closing the lid. This operation brings the sound-box into the correct position and starts the motor revolving at full speed almost before the lid is quite closed down. When played through, the sound arm is lifted and the motor stopped by just opening the lid. That, in brief, conveys some idea—I admit, an inadequate one—of this undoubtedly novel, yet withal practical invention. A future occasion may furnish me with an opportunity of fully describing the Sterno-phone, which, I believe, it is Mr. Sternberg's intention to place on the market at an early date. Few have as yet seen this new gramophone, but those who speak of it as representing a decided advance both in construction and tonal qualities over that of its confrere.

Zonophone Records of Merit.

A goodly program of music just suitable for prevailing tastes is this month (August) offered by the British Zonophone Co., with whom Colonial dealers should get into touch. The list under mention embraces a wealth of good selections contributed by London's most popular instrumental and vocal artists—the Black Diamond Band, Sydney Coltham, Peter Dawson, Florrie Forde, and Harry Fay among others. Altogether, a list of undisputed merit!

Discusses Edison Disc Records.

At a recent meeting of the North London Talking Machine Society, the president, Henry Seymour, demonstrated some Edison disc records and ventured upon a description of their cut, material, and the process of manufacture. He

said the material, if not actually celluloid, was of a celluloid nature resembling that used in the Amberol record. The cut was 150 to the inch. He had tested the records under fair conditions and found they gave the best results under a reproducer of 2½ inches in diameter (using a diamond point) fitted to the arm of an ordinary gramophone at an angle of 45 degrees or thereabouts. Mr. Seymour spoke very highly of the quality of these records, which he said represented the dawn of a new era, and set a standard to which all manufacturers would be compelled to work. The records were afterward played through, and for three hours the members of the society, all enthusiasts, sat entranced. It was generally conceded that Mr. Edison had solved the problem of mechanical music, and absolutely eliminated all objections, which any one could hold against the gramophone. Altogether, it was a delighted audience (there were many prominent gramophone men present) which, finally, but very reluctantly, turned toward home.

Jack Johnson at the Recording Horn.

The boxing champion has created many records, and by means of a record, of another kind, tells the story of how he has been able to do it. Johnson is apparently fond of music, at least, if the many hours spent at the Edison Bell West End Depot listening to records is any criterion. It was on one of these occasions that he received an invitation from J. E. Hough to make what will perhaps prove a more permanent record than those of pugilistic renown. Taking advantage of an early opportunity, Johnson, in company with his wife, made a direct journey from Paris to the Edison Bell recording laboratory and duly accomplished the object of his visit. The record is, doubtless, by this time on sale.

Osborne Believes in Advertising.

Notwithstanding that this is the generally chosen period when dealers regard expenditure upon advertising as useless, Thos. Edens Osborne, of Belfast, continues to make attractive use of

(Continued on page 46.)



To T.M. the King and Queen of Spain



To H.M. the King of Sweden



To H.H. the Khedive of Egypt



To H.M. the King of Italy



To H.M. the Shah of Persia



By Appointment To H.M. Queen Alexandra

"His Master's Voice"

—the trade-mark that is recognised throughout the world as the

Hall-mark of Quality

AUSTRIA: Oesterr. Gramophon-Gesellschaft, m. b. H., 8, Krugerstrasse, Vienna.
 BELGIUM: Cie. Française du Gramophone, 51, Avenue de la Porte de Hal, Brussels.
 DENMARK: Skandinavisk Gramophon-Aktieselskab, Frihavnens, Copenhagen.
 FRANCE: Cie. Française du Gramophone, 115 Boulevard Richard Lenoir, Place de la République, Paris.
 GERMANY: Deutsche Gramophon-Aktiengesellschaft, 35, Ritterstrasse, Berlin, S42.
 HOLLAND: American Import Co., 22a, Amsterd. Veerkade, The Hague.
 HUNGARY: The Gramophone Co., Ltd., IV, Kosuth Lajos-Utca 8, Budapest.
 SPAIN: Cia. Francesa del Gramophone, 56, Balmas, Barcelona.
 SWEDEN: Skandinaviska Gramophon-Aktiebolaget, 52, Appelbergsgatan, Stockholm.

RUSSIA: The Gramophone Co., Ltd., 45, Nevsky Prospect, St. Petersburg; 9, Golovinsky Prospect, Tiflis; 30, Nowia Svit, Warsaw.
 EGYPT: The Gramophone Co., Ltd., 13, Rue Stamboul, Alexandria; Rue Mousky, Cairo.
 EAST AFRICA: Bayley & Co., 8 Beira, Lourenço Marques.
 SOUTH AFRICA: Darter & Sons, Adderley St., Cape Town; Mackay Bros., Rissik Street, Johannesburg; Mackay Bros. & McMahon, 443, West Street, Durban; Ivan H. Haarburger, Maitland St., Bloemfontein.
 INDIA: The Gramophone Co., Ltd., 139, Ballaghatta Road, Calcutta; 7, Bell Lane, Fort, Bombay.
 AUSTRALIA: The Gramophone Co., Ltd., Hoffnungs Chambers, Pitt Street, Sydney.
 GREAT BRITAIN: The Gramophone Co., Ltd., 21, City Road, London, E.C.



Great Britain:

The Gramophone Company Ltd
 21 City Road London EC

[Patents Granted or Pending the World Over.]



“The World’s Musical Instrument”

PLAYS to *equal* perfection every disc record ever made, band, instrumental, orchestras, string organizations, tenor, baritone or bass; soprano, mezzo or contralto—irrespective of the make of the record or “cut” of same.

PLAYS Columbia, Edison, His Master’s Voice (Victor), Marathon, etc., records without additional attachments or change of sound boxes.

PLAYS to suit the small room or the large hall (without additional attachments or closing “doors”) and *its tone* is absolutely the same in every case.

BRINGS *independence* and *more profits* to dealers.

BRINGS increase of record sales to *all* manufacturers.

SOON READY

J. HOFFAY

67 Egerton Gardens, South Kensington, London, England

“MIRACLES HAPPEN EVERY DAY”

In the last issue of this journal we kind of proved it, so “nuff said”—BUT just take a note that we can supply Gramophones, made in such a way that all the trouble has been left out of them, at from \$2.50 each. We sold 20,000 at this price last year in this market alone.

As for Records—Needle Cut—10 inch double sided, made with the finest “stock” in the world—we can quote you prices f. o. b. London or otherwise, at your option—that no other firm—never mind how big they are—can approach. Try us and *write right now* for eye opener quotations.



BLUM & COMPANY, LIMITED

Manufacturers

Offices and Showrooms: 220 OLD STREET (Corner of City Road), LONDON, ENGLAND

Cables: Blumogram, London.

Codes: A. B. C., 4th Edition, Western Union, Reuters, Liebers.

Phones $\left\{ \begin{array}{l} 5048 \\ 5049 \end{array} \right\}$ London Wall.

FROM OUR LONDON HEADQUARTERS—(Continued from page 44).

local organs for the purpose of stimulating a wider appreciation of the gramophone as “a delightful relief from the monotony and quietude of life in the country.” This from Ulster is almost too good! Even rural life in Ireland one would have thought to be exciting, these days of political strife. Still, there is doubtless value in music that tends to soothe the savage breasts, only Mr. Osborne is too shy to admit it.

Joking apart, our Belfast friend is more than faithful in his belief in the value of publicity, especially under the circumstances which exist in Ireland to-day.

A Great August List.

An advance copy of the August “H. M. V.” list at hand, reveals a master mind at work in the choice selection of records itemized thereon. It is an aggregation of charming musical items, all of first-class merit, and sufficiently comprehensive to suit a variety of taste, be it gay or otherwise. This fine program commences with two 12-inch discs bearing Beethoven’s “Fifth Symphony”—Finale, Part III. and IV., which completes the set covering the whole of this magnificent and truly noble work. Mention should be made that the Berlin Philharmonic Orchestra under the baton of Herr Arthur Nikisch, is again responsible for a fine performance on both records. Among violinists of the fair sex, the pre-eminence of Miss Marie Hall is, if anything, enhanced by a piece of splendid bowing in her rendition of “Canzonetta, op. 6” (d’Ambrosio), which, as a solo, ranks among the best yet issued on record. A humorous number in the vocal section is “Souvenirs,” composed and rendered by Tom Clare, and those who favor concert parties will enjoy the “Great-Grandmamma” record by the Crampton Party. There is also the Minster Singers in a medley of “Sea Songs,” and the Light Opera Company who present some gems from “The Night Bird.” The ballad section is throughout good, and the full list coupled with that of the double-sided selections (omitting titles mentioned above) is as follows:

Twelve-inch, double-sided—“Sizihetta,” serenade (Von Blon), and “Turkish Idyll” (S. V. Hays), Band of H. M. Coldstream Guards; “Peg o’ My Heart,” one-step or turkey trot (Fischer), and “Horse Trot,” one-step or turkey trot (Davies), Metropolitan Band; “Two Little Dances, a la Minuctte, a la Gavotti” (Finck), and “Valse Joyeuse” (Finck), Mayfair Orchestra; “A Tango Dream” (Maxwell), and “Smiles, Then Kisses,” valse (Ancliffe), Jacobs and his Trocadero Orchestra.

Ten-inch, double-sided.—“Colonel Bogey,” march (Alford), and “Youth and Vigor,” march (Lantenschlager), Band of H. M. Coldstream Guards.

Twelve-inch, single-sided.—“Speak” (Tosti), Hubert Eisdell, tenor; “Spring’s Awakening” (Sanderson), Miss Evelyn Harding, soprano; “Somber Woods” (Lully, Arr. by A. L.), Robert Radford, bass; “Joe, the Gipsy” (Batten), Harry Dearth, bass.

Ten-inch, single-sided.—“Genevieve” (Tucker), John McCormack, tenor; “Das Wandern” (Schubert), Sir George Henschel, bass; “Just,” (Bradford), Miss Alice Lakin, contralto; “Our Land of Dreams” (Thompson), Miss Gertie Dickeson, soprano.

Some Striking Publicity.

In accordance with a prearranged plan of campaign for the summer months, His Master’s Voice Co. lead the way in regards to newspaper publicity, some striking full page and half double-column spaces having been taken recently in the chief organs of the press. I have it on good authority that the result is highly satisfactory, sales this last month or so when, be it noted, even general business eases up, proving that this expenditure is well justified. The company’s agents have enjoyed the full benefit of the scheme, for inquiries are, as usual, tabulated and passed on to the dealer or dealers from whose locality they emanate.

New Companies Incorporated.

Diamond Disc Record Co., Ltd. Capital, £200. Office: 81 City Road, London, E. C.

National Gramophone Co. (1914) Ltd., trust deed to secure £6,000 third debenture stock, charged on certain inventions and patents and the company’s undertaking and property, present and future, including uncalled capital, subject to first mortgage debentures and such second debenture stock outstanding. Trustees: J. V. E. Taylor, 41 King William street, Strand, W. C., and F. Adler, Throgmorton street, London, E. C.

The Man of Many Parts.

W. H. Reynolds, of above fame, announces that expansion of business compels larger premises. He has, therefore, removed from Great Eastern street, and Hinton road, to a centralized warehouse at 45 City road, London, until lately in occupation by The Favorite Record Co. In conversation with the writer, Mr. Reynolds made the claim that he now stocks over one thousand parts and accessories for different makes of instruments.

An interesting reference to the time, not far ahead, when wireless telephony for commercial purposes will be possible, is made in the report presented by the directors of the Marconi Co. at the annual meeting. Rapid progress, says the board, has been made in the development of wireless telephone apparatus, and the company has recently introduced a practical and commercial set for moderate distances. Further important developments are proceeding, and it is contemplated that apparatus will shortly be available for the transmission of speech over considerable distances. Signor Marconi himself states that he expects to be able to telephone by wireless to New York before the end of the year.

A Remarkable Age.

To be sure this is a marvellous age. Commercial enterprise and science have contributed to the establishment of a complete wireless installation on a traveler’s motor van, enabling him to communicate immediately at any time of the day with his firm—the Ardath Tobacco Co., of London. The equipment has a radius of twenty miles. The method adopted for completing the

FROM OUR LONDON HEADQUARTERS—(Continued from page 46).

circuit and making "an earth" is by dropping a metal chain on to metallic manholes, on drains, or by trailing the chain in water. Wonderful!

Trade Conditions in Germany.

Some indication of trade conditions in Germany is found in the fact that one of the principal record companies, i. e., the Kalliope Aktiengesellschaft made a loss of over one million marks on last year's trading. The actual amount is given as 1,051,852 marks. This is very obviously a most serious matter, especially having in mind that the company's capital is but 1,470,000 marks. An affiliated concern, the Anker Phonogram Co., has paid its way and will continue trading, although it is a heavy creditor of the Kalliope firm. At the moment of writing it has been decided that both concerns shall continue trading subject to the voting result of the creditors who will meet to discuss the pros and cons fully.

The Linguaphone System.

The gramophone as an aid to the study of foreign tongues is being brought into prominence by Blum & Co., Ltd., 220 Old street, London, E. C., who have issued a series of French and German records on what is known as the Linguaphone System. This is a simplified method whereby with the aid of specially prepared text-books the student is able to follow the words and sentences on the record and repeat them frequently until perfect pronunciation is assured.

Announce New Models.

Blum & Co.'s new gramophone models for the coming season have now been submitted to the leading factors and we understand they have been much approved and are considered to be a distinct advance in construction. The cases and tone arms are of new design and said to be practically frictionless. The motors have been brought right up-to-date and brass to brass small gears have been entirely eliminated. Messrs. Blum state they are using their unbreakable springs which gave such unqualified satisfaction last season. These springs are made of French steel and tempered by a new process. They cost twice as much as ordinary springs, but that is counterbalanced by the confidence which their use inspires in the dealer and customer.

Messrs. Blum's hornless machines are all of new design, and although some of them sell to the factor at less than \$3, they give a loud, clear and resonant reproduction. They are turning out over 70,000 of these small hornless machines for one house abroad. Messrs. Blum say, "Give us quantities and we will figure with any house in the trade."

Over a Hundred Melodies in Medley Form.

Two of the most interesting records of the season give the presentation by Columbia of a new copyright arrangement of over a hundred melodies, under the name of "Tangled Tunes." The tunes so tangled, include classical, operatic and popular excerpts, strung together in irresistibly fascinating, and in many cases, amusing sequence. Thus, we have the first part opening with "Rule, Britannia," dropped straight into "Three Blind

Mice," which again breaks into "The Mistletoe Bough," and so on, every melody being distinct and easily recognizable—a clever collection arranged by Albert W. Ketelbey.

To make these records of additional interest, the list of melodies so introduced has been rearranged in alphabetical order instead of in the sequence in which they occur in the records. This has been done for two reasons—one to provide the purchasers with the novel and interesting task of testing their knowledge of music by arranging them in their proper order, the other to afford an opportunity for a novel prize competition.

For this latter purpose, too, twelve of the most familiar airs in the records have been omitted from the printed list—three from each of the four parts—so that the hearer of the records has the additional task of supplying the omissions. This, however, is easy, for the airs so omitted are, we are informed, as well known as "God Save the King."

The Columbia Co. announces the first recordings this month of Miss Rosini Buckmann, soprano of the grand opera season at Covent Garden. Her representation includes the "Black Bird" and the "Fairy Pipers." Other records of interest are the Barcarolle from "The Tales of Hoffmann" as a duet, sung by Andrea de Segurolla, basso, and Mme. de Pasquali, soprano; the waltz song from the musical play, "Adele," which is issued as a 10-inch Columbia Rena record, and the musical hits from the play to be had in a 12-inch record in the same list.

"Queen of the Movies," one-step and the two vocal numbers, "In the Night" and "Oh, Cecilia," are also proving big sellers. Will Oakland, the well-known counter-tenor is back on the Columbia list this month and his singing of "The Lass From County Mayo" and "You Can't Make Me Stop Loving You" made a Columbia Rena record of great merit.

A great Wagnerian soprano in one of the greatest of all Wagnerian roles—that is a fitting description of the new record by O'ive Fremstad issued in the Columbia grand opera series this month. A continuous demand for more excerpts from her heroic Wagnerian roles has induced Mme. Fremstad to record the beautiful "Liebestod" from "Tristan and Isolde" an opera which this artist has made peculiarly her own. With this superb number has been combined Verdi's famous old aria, the one surviving air from "Don Carlos."

JAKE GRAHAM "AT THE OLD STAND"

In Business Harness After a Remarkable Trip Around the World—Tells of the Extent of His Travels Which Have Been the Subject of Much Comment in the Liverpool Papers.

(Special to The Talking Machine World.)

LIVERPOOL, ENG., August 3.—Jake Graham, the prominent gramophone man, of 74-76 Renshaw street, who has just returned home after a trip around the world, has been interviewed and

"written up" by the newspaper men in the local papers at considerable length, who have found in him a veritable mine of information. In the course of a chat with The World representative he said:

"I arrived home after my wanderings and wonderings in strange countries, which commenced at Southampton just over twelve months ago; New York, my first stop, where I got in touch with the heads of our trade, also visiting the Victor, Columbia and Edison factories, and getting information first hand, which will be of great benefit to me. Now I've returned to manage my business here. I've got my back to the wall and the old flag will fly higher than ever, though, I must say, I'd love to return to America (somewhere warm) and handle the talker, because I see enormous possibilities your way that don't and cannot exist here.

"After spending about two months in New York and district I went right through the States to the New York of the West, 'Seattle,' stopping and visiting on my way, Niagara, Buffalo, Chicago, St. Paul, Yellowstone Park, etc. After doing Seattle, a place where the natives seem to have heaps of energy and everything was very prosperous, I went on to Victoria, which was typically English; then on to Vancouver, where I made great chums and friends, especially with Mr. Switzer, of Fletcher Bros., who treated me like a brother. Then on to my goal, Honolulu, where I stayed for nearly seven months, and where I had many interesting experiences, one in which I nearly lost my life, being lost up the mountains (having to make my bed up a tree), but which ended (much of my experience as an athlete) eventually in my getting out of the terrible fix I was in. Then I went on to the Fiji Islands, Suva being most interesting to me, and on to New Zealand (Auckland), then on to Sydney, Melbourne, Adelaide, Fremantle. I then journeyed to Ceylon (Colombo), Aden (Oh, what a gray, dry spot it is); Suez, on through the canal to Port Said, to Messina, Marseilles, Gibraltar, Tangiers, and on to Plymouth for London, to visit my friends in the trade; and on to Liverpool to tackle my business again, where I'm sure my customers are jolly pleased to see me. Things have improved since my return, and I'm looking forward to the biggest season (so called, no need to be a season trade) in the history of my affairs, and for the trade generally."

During his visit to New Zealand Mr. Graham met his brother, who is connected with a large piano house in that city. Needless to say, the meeting was a joyful one.

Many queer expressions of praise for the talking machine reach the dealer. "Since we got our Victrola I find the children awake when I get home and dinner is usually late," is a testimonial received from a New York manufacturer.

Perhaps more men would go to church if they had to sneak in through a side door.

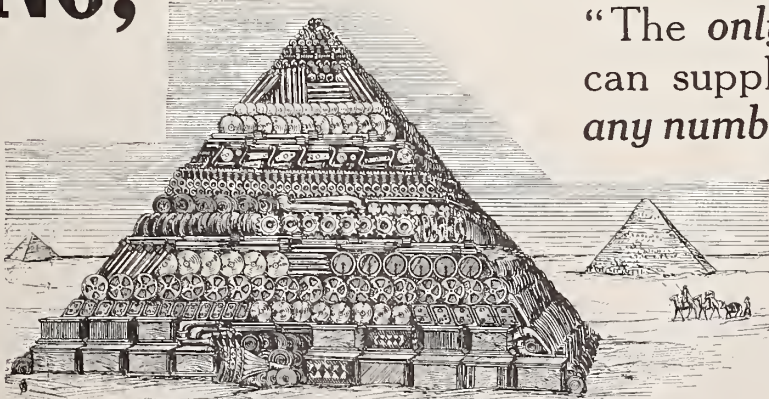
"RENO, THE MAN OF MANY PARTS"

"The *only* man in the world who can supply you with *one* part—or *any number* of parts for *any* Talking machine *ever* made from Adam to Edison."—Roosevelt.

64 Page Catalogue Yours for Asking

W. H. REYNOLDS, Ltd.

"KNOTASLEPE"

London, England

WHO SAID TEXAS WAS NOT RIGHT UP TO DATE?

Proof Adduced That It Is in the Enterprise Manifested by the Gunst Piano Co.'s Exploitation of the Victrola and Public Display of Dancing Which Interested Thousands.

(Special to The Talking Machine World.)

CORPUS CHRISTI, TEX., August 3.—New Yorkers must not get away with the idea that Texas is not up to date. Thanks to the Victrola, this State is keeping quite in line with terpsichorean developments, and this was forcefully and pleasingly

parade the float was stopped at the street crossings, the latest dances on the Victrola started and an exhibit given of the latest dances for the edification and education of the crowds looking on, thus demonstrating the fitness of the Victrola for dance purposes. Needless to say, the float attracted



Public Exhibit of Dancing to Music of the Victor.

demonstrated in the display made by the Gunst Piano Co. during the Fourth of July celebration in this city.

As may be seen from the illustration, the Victrola was used on the float, and two professional dancers engaged for the occasion. During the

NEW PLAN FOR DISC DISTRIBUTION.

Thos. A. Edison, Inc., Announces New Plan for Distributing Disc Records Which Has Many Merits That Will Appeal to the Trade.

Thomas A. Edison, Inc., announced to its trade this week a new plan for the distribution of Edison disc records which should prove considerably superior to the present plan of distribution. This plan was submitted some time ago to Thomas A. Edison, Inc., by the executive committee of the Edison Disc Jobbers' Association, who gave the company every assurance of the jobbers' and deal-

ers' co-operation if the plan is accepted by the company.

As formally announced by the company, the new plan presents the following important points: "We discontinue at once the present method of infrequently listing records in supplements. Instead, we shall begin to manufacture and ship weekly supplements of six records. The records will be numbered in the usual way.

"Under the new plan there will be no constant and universal date on which the records are to go on sale. Instead, an entirely new arrangement has been adopted by which the supplements are to be

released for sale by States. This is the way of it; when each jobber receives his shipment he immediately wires to the factory a notice of the fact. When all jobbers doing substantial business in any one State have been heard from, the date for mailing supplements and placing the records on sale in that State will be wired by factory to each of such jobbers. In this way the factory, as far as possible, will endeavor to prevent encroachments upon territory and unfair advantage being taken by one jobber of another. When the jobber fills the dealer's weekly supplement order for new disc records he will invariably accompany the same with a communication containing the following: 'The date on which Thomas A. Edison, Inc., authorized these records to go on sale in the State of _____ is _____ (here date will be inserted). They must not be displayed, demonstrated, offered for sale or sold before 8 a. m. of that day.'

"Dealers will be required to observe this strictly.

"It is understood that the factory is not to be held to a hard and fast obligation to continue to supply six new records each week. It may sometimes be necessary to run over, say, ten days or more in getting out a particular supplement of six records, but the weekly schedule will be resumed in such instances as soon as possible."

The company states further that there are many advantages incidental to the new plan of distribution, most important of which are the following:

"It insures an immediate and continuous flow of absolutely new records and in satisfactory quantities with which to attract the interest of the prospective customer and retain the good will and invaluable 'boost' of the old. The listing of a new record practically every day is a strong talking point. The weekly lists of new records give the dealers a great opening for newspaper advertising and show window placarding.

"It contributes to the rapid building of a representative catalog.

"It enables the factory to list timely, popular selections and place them in the hands of the trade when the wave of their popularity is on the rise. Fully two months' time will be gained in this way, and no jobber will receive an advantage over another, as is the case under the present scheme, where a selection may have lost its popularity in some sections of the country by the time it is listed—although still popular in other sections.

"It does not confine the factory to an announced, cataloged supplement, in manufacturing which unforeseen delays may present themselves to the common disadvantage of all concerned.

"It makes it possible for the factory to incorporate in a weekly supplement selections that have taken on a new spurt of popularity or on which the demand has greatly exceeded the original orders; as also may selections that we have been unable to supply and that are now temporarily withdrawn."

TAXING COMMERCIAL TRAVELERS.
Taxes Imposed by South American Countries on Traveling Men Are Far from Being Prohibitive to the Average Exporter.

Taxes imposed by South American countries on commercial travelers are far from being prohibitive to the average exporter. While various license fees are prescribed by law in those countries, their purpose, as explained in a report just issued by the Bureau of Foreign and Domestic Commerce of the Department of Commerce, is chiefly to prevent unfair competition with local concerns, which are themselves subject to similar taxes. By associating himself with some local house, the traveler may obtain exemption from all but a few of the more moderate taxes. The rates of license fees and the conditions under which samples may be temporarily admitted free of duty in practically all the countries of South America are shown in the report, entitled "Commercial Travelers and Samples in South America" (Tariff Series No. 19A), copies of which may be purchased for five cents each from the Superintendent of Documents, Government Printing Office.

Special

Send for a package of our Improved Half-Tone and Loud Tone Needles in New Style Envelopes.

If you want to advertise yourself, we will put your own name or trade-mark on the envelopes, or will pack in Puritone envelopes.

Quality Guaranteed

The Best Needles mean profit and satisfaction.

If you want to sell 1,000 Needles at a time instead of 100, use the "Dean-packed" Needles. Five boxes of 200 each, Extra Loud, Loud, Opera, Medium and Soft packed in a carton. The best package and fastest seller on the market. Write for samples.

JOHN M. DEAN, CORP.

Talking Machine Needle Manufacturers

PUTNAM, CONN.

PLAYING THAT FIRST RECORD.

Find the One Piece of Music That Means More to Your Prospect Than Any Other and the Deal Will Be Made Then and There.

When you have a Victor or Victrola prospect up to the point when he wants to hear the instrument, let him choose the first record you play; in fact, make him choose it. To come "pretty close" is not coming close enough.

Music is a curious thing. It makes a more direct appeal to the emotions than any other thing in the world. The tremendous descending chords of the Chopin funeral march bring home the poignancy of death more vividly than any other element in the most impressive funeral service. The vivacity of a well-written, well-played piece of rag-time will tickle the feet and good humor of the most inveterate grouch. Not literature, not art, not even the breezy clatter of a sympathetic friend, can so subtly and so swiftly lift us from one condition of mind to another. If you doubt it play "Dixie," and then for contrast sake play the "Unfinished Symphony," and you will realize that the music itself can make a much more powerful appeal than the most skilfully chosen phrases at your command.

There is always some one favorite piece—some musical composition which is laden with association either grave or gay for every single individual except the few, the very few persons who are tone deaf, says "The Voice of the Victor."

That is a point which no good salesman should overlook. Take a little time or a lot of time, but keep at it as diplomatically as you know how, and don't play anything for that customer until you are sure the thing you are to play means something to him.

A very frequent mistake and a very natural one is to play the things which appeal to you. Don't do it. Carry a list in your mind which has little or nothing to do with your own musical taste, but which contains the best known things from hymn tunes to symphonies, and make your customer choose for himself.

He is likely enough to say, "Yes, play that!" by the time you have suggested half a dozen, but if you watch him closely you will find that he says it in a perfunctory sort of way. Keep on suggesting. Before you get very far you will see his eyes brighten at the name of some record. Eagerness will take the place of casual interest. It will show in his eyes, in the tone of his voice and his quickened gestures. Then you have it. Play that record and see that there is no interruption. If you are in a demonstrating booth, use a half-tone needle. It will be easy enough to show him later, how much volume can be developed, but for that first playing sacrifice everything to smoothness and melody. Usually it is a mistake to use a big needle in the restricted space of a demonstrating booth.

The selection may be a hymn tune, a band piece, a violin solo, a dance, an opera number, a symphony, or what not. That is unimportant, if, for a few moments you give that man a glimpse of half-forgotten joys or sorrows, for, as a writer in *The Voice of The Victor* says, in those few moments the Victrola will have been changed by the swift alchemy of imagination from a merely beautiful piece of cabinet work to the essence of things hoped for in the past or dreamed of in the future.

EDISON FIELD DAY ENJOYED

By the Employes and Officials of Thos. A. Edison, Inc.—More Than 2,500 Present—Thos. A. Edison Honorary Referee.

Thomas A. Edison and a group of the officials of his several manufacturing interests directed the sports and games attendant to Edison Field Day, which was held recently at Olympic Park, Irvington, N. J., a suburb of Newark, N. J. This day is a banner one for the employes of the Edison plants, and the attendance this year was a record-breaker, more than 2,500 persons being present. The invited guests embraced employes from the Edison factories at Orange, N. J.; Silver Lake, N. J.; those of the Edison Bronx Studio, and of the Edison Portland Cement Co., Stewartsville, N. J.

Mr. Edison acted as honorary referee at the many hotly contested games and pitched the first ball in the Edison league baseball game, which was won by the Edison Bronx Studio from the office employes of the Orange factory by a score of 10 to 7.

One of the added attractions to the meet was a trotting race between horses driven by C. H. Wilson, vice-president and general manager of the Edison interests, and William Maxwell, second vice-president. Mr. Wilson won the last two heats after a close finish.

DOUBLE-DISC RECORD CATALOG.

The Semi-Annual Catalog Issued by the Columbia Graphophone Co. Is Imposing in Size and in the Character of Its Contents—Admirably Produced Typographically.

The Columbia Graphophone Co. has just issued its regular semi-annual double disc record catalog, which is considerably bulkier than the preceding edition and contains 464 pages. There are 1,720 double disc records listed, which, together with a few single discs, give a total of about 3,500 musical selections in the new Columbia book.

A number of new artists are presented in this catalog, a few of the most important ones being Maggie Teyte, Miss Margaret Woodrow Wilson, Oscar Seagle, Charles Clark and Louis Kreidler. These artists had not recorded any selections prior to their engagements with the Columbia Co.

The indexing and cross-indexing is simpler and more complete than ever before. A number of minor improvements are embodied in the indexing arrangements, conducing to the maximum convenience of the dealers and their patrons. Apart from the actual list of titles there is considerable information concerning artists and composers that is well worth the attention of users of the book. It is well printed on good paper and strongly bound together.

Never be so well satisfied with your work that you can't see how it might be improved.

An Added Line That Will Make You Money



The H. P. Nelson Small Grand

The talking machine dealer can carry a small stock of pianos to the greatest advantage because he is the possessor of certain natural facilities that, of themselves, bring him sales.

The profits on a piano sale are large. The expense of carrying a few instruments is almost negligible and their sales come oftener than you, perhaps, think.

Our line of uprights, players and grands is especially adaptable to the wants of the talking machine dealer who to a certain extent relies upon the instrument to sell itself. We have built up a tremendous business upon our policy of giving the greatest return for the least money and the value of our products is so apparent that even those least acquainted with pianos are instantly aware of their worth.

Get our special proposition to you

H. P. NELSON COMPANY

816 N. Kedzie Avenue, CHICAGO



Not that we relish depending on other folks' calamities for our own good fortunes, but this European war certainly is the most active trade tonic that ever happened to those talking machine dealers who are carrying Columbia foreign records.



(Write for "Music Money," a book "full of meat" for those dealers interested in quick and frequent turnover of capital.)

Columbia Graphophone Company
Woolworth Building, New York

TRADE CONDITIONS IN BALTIMORE.

Satisfactory Reports Made by Talking Machine Dealers—Showing for Past Month Above Average—Vacations Much in Evidence at Principal Houses—News of Month.

(Special to The Talking Machine World.)

BALTIMORE, Md., August 8.—While the warm weather and other matters that have held the center of the public attention during July have naturally had the effect of cutting down the volume of business done in that month as compared with previous months, the showings made by the various dealers as a whole were very satisfactory to all concerned. The month as a whole showed up better than July of 1913, and the dealers are very confident that the war or no other cause is going to have any bad effect on the trade during the coming fall and winter. They are still mapping out plans to break all previous records.

Manager S. A. Dennison, of the local branch store of the Columbia Graphophone Co., has returned from Rehobeth Beach, Del., where he spent a most delightful vacation. Mr. Dennison reports a number of good sales of machines and records during July, including higher priced machines.

Manager W. C. Roberts, of the E. F. Droop & Sons Co., has gone to Atlantic City for two weeks after closing out a very satisfactory July with the Victor and Edison machines and records. A number of Victrolas were disposed of during the month, while demands for high priced records came in very strong.

Joseph Fink, proprietor of the Fink Phonograph Co., reports a very substantial month with the Victor and Columbia lines. Mr. Fink is preparing to spend his vacation at Atlantic City for a rest in order to tune up for the coming fall and winter campaign.

The Victor line also went off well at the store of H. R. Eisenbrandt, which handles this line. The sales were rather substantial for July and high priced records were very much sought after.

At the store of the Sanders & Stayman Co., Inc., it was reported that the Columbia and Victor lines came in for their shares of the profits during July and indications are for a fine fall and winter trade. Manager Holmes, who has charge of the piano and talking machine departments for Gom-

DAHLBERG TALKING MACHINE CO.

Is a Progressive House Which Believes in High Class Advertising and Gets Results—Handles the Columbia Line with Marked Success.

(Special to The Talking Machine World.)

MONTGOMERY, ALA., Aug. 7.—One of the successful talking machine stores in the South is the

company closing a constantly increasing business.

As will be seen by the accompanying illustration, the Dahlberg Talking Machine Co. thoroughly appreciates the sales value of attractively furnished warerooms, and the atmosphere of comfort which is apparent even in this photograph is characteristic of the entire warerooms.

The company handles the complete Columbia line, making a specialty of developing the trade in

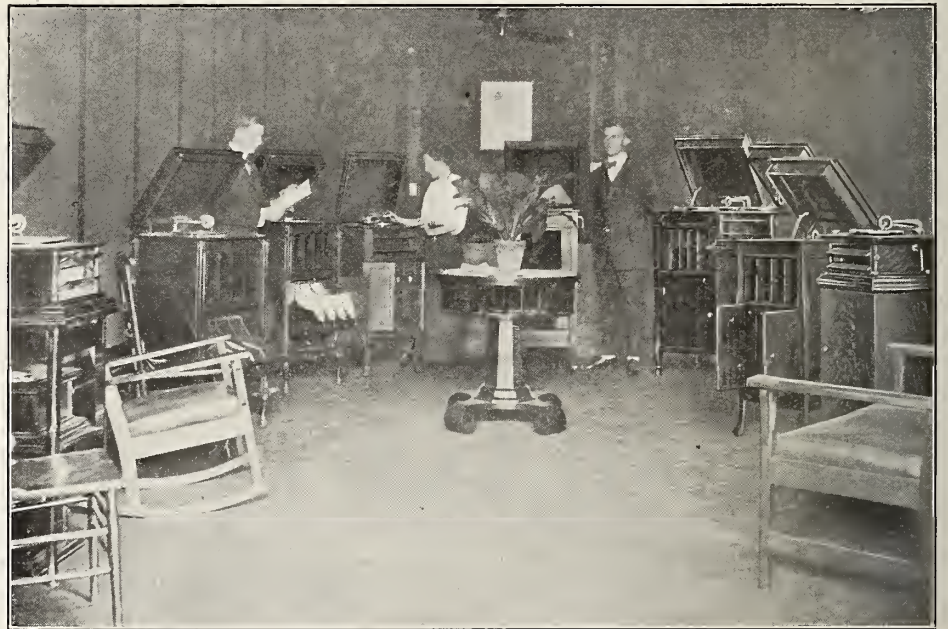

View of Attractive Showrooms of Dahlberg Talking Machine Co., Montgomery, Ala.

Dahlberg Talking Machine Co., of this city. This house is a consistent advertiser in the local newspapers, which, coupled with energetic sales efforts along progressive lines, has resulted in the

the higher priced Columbia machines. In the picture, reading from left to right, are seen E. W. Dahlberg, manager; Miss Clara Patterson, secretary; M. T. Ansley, assistant manager.

precht & Benesch, reports a good business for July with the Victor line, which the firm handles. Prospects also point to a good demand all during the fall and winter.

Some ad writers put so much "punch" in their copy that the Reader is knocked out.

Make your show windows work.

A PROFITABLE SIDE-LINE.

One of the side lines with which many talking machine dealers are making money are Icy-Hot bottles, made by the Icy-Hot Bottle Co., 122 West Second street, Cincinnati, O. A new catalog of these bottles has just been issued, which illustrates and describes the complete line of bottles, pitchers, carafes and other styles made by the company, giving a comprehensive idea as to the scope of these products. Icy-Hot bottles are guaranteed to keep water steaming hot for twenty-four hours or icy cold three days, regardless of outside temperature, and talking machine men give them a leading position under the heading of "valuable side lines," for they are sellers.

PROF. DE CHAUVENET PRAISES DISC.

Having recently heard the "Overture from Mignon" on the new Edison disc phonograph, I became so enthusiastic over the perfection of the music that I cannot refrain from writing the actual fact that the record was clearer and more vividly realistic to me than an actual rendition which I chanced to hear at the Opera Comique at Paris last September. I wish the Edison disc continued appreciation for its grand work.—Paul De Chauvenet, dean of the De Chauvenet Conservatory of Music, Los Angeles, Cal.

Triumphon Co., Ltd., Berlin, S. W. 47/5

Established 1884

**Manufacturers
Motors, Soundboxes, Tone Arms
Complete Talking Machines**

APPLY FOR CATALOGUES



Piccolo is a complete Talking Machine. Easily to be carried like a portmanteau. Most suitable for picnic or rover parties in summer, and easily carried to social gatherings in winter. Plays 12-inch records. Is not a toy. Weight without records, only 5 kg. Measurements: 11 x 13 3/4 x 7 3/4 inches.

Special Motors HYDRA SYSTEM Single and double spring, six different models. Are the only existing construction which allows the exchanging of the spring and spring case without taking the motor out of the cabinet. After loosening one nut, a child is able to replace any defective spring or springbox within 20 seconds.

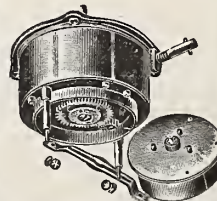
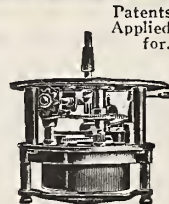

Patents Applied for.

THE BUSINESS BUILDING POSSIBILITIES OF A RAINY DAY.

Some Pertinent Comments Which Demonstrate the Fact That Even Stormy Weather May Be Turned to Good Account by the Progressive Talking Machine Dealer—Some Hints in This Connection That May Prove Valuable and Stimulating.

I know a talker man who has added greatly to his list of customers by specializing along the lines of rainy day concerts. He tells me that the more tempestuous the weather, the better the results, and that he has actually reached the stage where he prays for a storm. What do you know about that? His methods of straining dollars from rain drops are somewhat unique, and I'm going to tell you about them: He gathers together a catalog of hotels, cottages and private homes at some resort not too far distant from his city embodying the names of owners and regular guests. When a stormy day comes along during the vacation season he sends out his salesmen laden with talking machines and a very carefully selected repertoire of records. These salesmen are particularly well trained in their profession—they are artists, diplomats and gentlemen.

Now, Mr. Dealer, accompany me for a few moments, if you will be so kind, to a stuffy hotel exchange, or, if you'd rather, out upon a crowded cottage veranda, with nothing on earth to do but listen to the monotonous patter of the rain and say unkind things concerning the beastly elements. A very rotten environment, is it not? However, upon this particular occasion, just as we have reached the superlative degree of gloom, and are about to get in touch with the clerk regarding the next train to town, we descry a mackintosh figure swaggering up the drive in company with two carrying cases and a sunny smile. We scent a change for the better and, temporarily at least, withhold our requests for timetables.

He enters into our midst with a buoyant stride and bearing the best of news, to wit: He has been sent to us to stamp out the prevailing epidemic of blues with good music. There follows a perfectly delightful talking machine concert which proves so entertaining that all thoughts of the deluge without are cast aside, and for two enchanting hours we bask in the sunshine of the world's best humor and melody. At the end of the concert everyone is in a most receptive mood, of course, and the gentleman, who has been so very kind to us, takes advantage of this fact to pass around his literature, at the same time giving us a concise and interesting lecture upon the advantages to be derived from owning a good talker outfit. He then proceeds to book orders and, believe me, he books them, too. My friend, the dealer, assures me that as a business building proposition the rainy day concert at the summer hotel is eminently successful.

I will not dwell upon the tango craze, except to remark that if at the end of an entertainment the audience expresses a wish to indulge in the hesitation, trot or one-step, the operator should be in a position, not only to play the correct music for the various steps, but to fill the role of dancing master as well. If your salesman can introduce a new clutch or dip while among the dance-mad folk

at the summer resort, he will at once become the most popular man about the place, and that means orders, does it not? If you do not believe that this is true, just ask a sweet young debutante, summering at Hainesport-on-the-Rancocas, if she has danced the camel amble, and if she hasn't behold her face ablaze with the flame of desire, and listen attentively while she pleads with you to teach her. You can take it from me that the dispenser of talking machines who is also a good tango instructor will prove himself a "bear" at any place where people with leisure on their hands congregate in the good old summertime.

This dealer friend of mine carries his rainy day campaign into the homes of his would-be cus-



Shopping on a Rainy Day.

tomers also. He achieves success somewhat as follows: When a regular customer—we will call him Smith—drops in to purchase new records, or to ask advice upon some subject relating to talking machines, the dealer asks for the names of Smith's friends who have talkers, and also of those who have not, but who have expressed themselves as pleased with concerts they have heard at Smith's home. This accomplished, when a nice wet day comes along, Smith's acquaintances are called upon by a courteous salesman who makes himself very agreeable, playing records, making notes of the selections that are liked best, for future reference, and probably giving a few dancing lessons.

This salesman makes it plainly understood at the outset that there will be no obligation to purchase connected with his visit, explaining that the house he represents has inaugurated a series of sunshine concerts for rainy days. He explains further that it is the idea of his firm to banish gloom and to advertise its wares simultaneously. This little preaching gives the impression that there is a good opportunity, absolutely devoid of strings, to get something for nothing, and they snap at it like a famished trout at a fly.

Having gained the undivided attention of his hearers, he carries through the same sort of program as described previously in this article, making a pronounced hit and obtaining many prospects and some orders.

In his store, too, this dealer pushes the rainy day concert idea to the limit. He tells the public through the medium of an appropriate and carefully thought out window display how cozy his store is while the storm beats down outside, and that for everyone who calls will be played records positively guaranteed to bring sunshine into the heart despite the inclement weather.

There are hundreds of records, Mr. Dealer, particularly well adapted to rainy day rendition. Such artists as Harry Lauder, Cal. Stewart, Steve Porter, Collins & Harlan, Golden & Hughes and a horde of others have the ability to make one forget everything, but how to laugh uproariously. Hence these are the fellows to introduce to the folks who come to see you when the spray flies against the windows, when the pavements are aglitter with moisture, and the gutters are running brooks.

When the public gets to hear of the place that makes a specialty of rainy day concerts it will take advantage of the opportunity to spend a pleasant hour. Bad weather has a tendency to breed pessimism, and if a chap feels blue as well as wet, he is in pretty bad shape. When he finds that by a visit to your cheer factory he can receive a free injection of optimism for the asking, he'll come all right, and eventually he will take a talking machine outfit away with him, too; you see if he don't. He'll want to be optimistic at home as well as abroad, and a talker with a few really funny records is the greatest antidote for gloom that ever happened. Would you believe it? I have been in talking machine shops on rainy days when everyone from the boss down to the errand boy was grouchy to a terrible extent. If you asked them about it they would answer in surly fashion: "This d— weather's killing business." As a matter of fact, I had an experience similar to the above just the other day in the good old Quaker town of Philadelphia. I told them to cheer up and read the August World, hinting that they might find a cure for their malady within its covers. Here's hoping that this article may help some.

Candidly, now, Mr. Dealer, do you not think there is something in the idea of rainy day concerts? Have you not found that business is practically at a standstill when the weather is bad? Of course, you have, and the remedy is before you. Make your store attractive and home-like, speak about it to the people through your advertising and your window, inviting them to come and listen to some sunshine records 'til the clouds roll by. You will find that they will be only too glad to avail themselves of your courteous invitation. If they come once and enjoy themselves sufficiently, it is a cinch they'll come again; yes, and bring others with them, which means for you a steadily increasing business—but why continue; I've said enough. Let it rain!

HOWARD TAYLOR MIDDLETON.

Beka Records

IN ALL LANGUAGES OF THE WORLD

High grade selections in

German, English, Italian, Spanish, Portuguese, French, Swedish, Slavonic, Ruthenian, Danish, Norwegian, Russian, Polish, Hungarian, Bohemian, Rumanian, Tschechisch, Croatian, Servian, Hebrew, Turkish, Persian, Arabic, Chinese, Malay, Japanese and seventeen different Indian dialects.

The cheapest and best machine on the market for \$2.50 upward

BEKA-RECORD AKT. GES., Berlin, S. O. 36 (Germany)

CATALOGUE IN FOUR LANGUAGES SENT FREE ON REQUEST

LATEST PATENTS RELATING TO TALKING MACHINES AND RECORDS

(Special to The Talking Machine World.)

WASHINGTON, D. C., August 8.—TALKING MACHINE.—Thomas H. Macdonald, Bridgeport, Conn., assignor to the American Graphophone Co., same place. Patent No. 1,099,928.

The object of this invention is to produce a so-called "hornless" talking machine, or machine with inclosed horn. More particularly, the invention consists of the compact and efficient arrangement

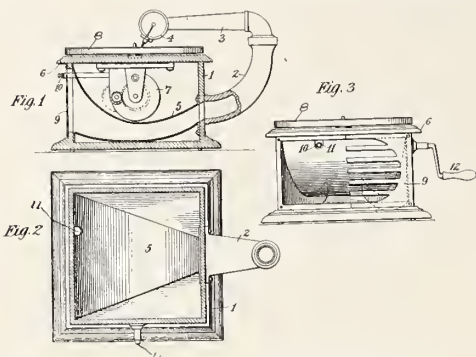

of the various parts without sacrificing the efficiency of the machine or the quality of its reproduction of sounds.

In the drawings Fig. 1 is a vertical section taken longitudinally through the middle of the sound conveyor or "horn." Fig. 2 is a plan view of the machine, with the motor and the cover or lid of the cabinet removed, and Fig. 3 is a front elevation partly broken away.

DICTIONATION GRAPHOPHONE.—Thomas H. Macdonald, Bridgeport, Conn., assignor to the American Graphophone Co., same place. Patent No. 1,100,024.

This invention relates to talking machines employed for dictation purposes, where both a recorder and a reproducer are required, and where it is also desirable at times to throw the parts out of gear while the motor is still running. It has been proposed to locate the recording stylus and the reproducing stylus upon a diaphragm common to both, and then, by shifting the position of the diaphragm, bring either of the two styluses into play. But entirely satisfactory results are not obtained in such constructions for two reasons: In the first place, other things being equal, and within reasonable limits, the lighter the recording device the more sensitive it is, and the better it will record; whereas a reproducing device acts better the heavier it is. In the second place, a recorder should have the vertical play necessary to adjust itself to any unintentional eccentricity of the blank cylinder, but should not have any lateral play; whereas the reproducer should have not only the vertical play, but also sufficient lateral play to enable it to track the helical record groove of the sound record. It has also been proposed to have two "speakers" interchangeable upon the machine, one a recorder and the other a reproducer, in order to provide the two differing qualities just mentioned.

It is the object of the present invention to provide in a single construction a "speaker" that is

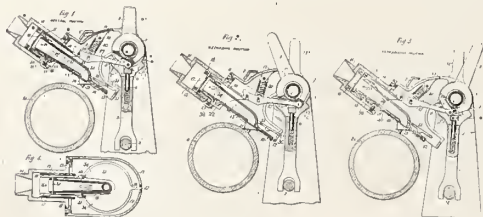

capable of ready adjustment into each one of three positions (1) where it becomes a comparatively light recorder having vertical play but no lateral play; (2) where it becomes a comparatively heavy reproducer having both lateral and also vertical play, and (3) where it is neutral.

The invention consists, then, of the speaker carrying the recording stylus and the reproducing

stylus upon a common diaphragm, in combination with the ordinary "start-and-stop" mechanism and suitable attachments and connecting devices by which the adjustments above referred to may be accomplished.

Fig. 1 is a vertical section through the parts upon an ordinary graphophone or other talking machine, showing the "speaker" in its inoperative or "neutral" position; Fig. 2 is a similar view, showing the device adjusted to become a "recorder;" Fig. 3 is a similar view, showing the device adjusted to become a "reproducer," and Fig. 4 is a substantially horizontal section taken through the speaker and its connecting parts.

CABINETED GRAPHOPHONE.—William C. Fuhri, Chicago, Ill., assignor to the American Graphophone Co., Bridgeport, Conn. Patent No. 1,099,353.

This invention relates to an improved "cabineted graphophone," that is, the combination of a graphophone and an ornamental and useful casing or cabinet which contains and completely incloses the former,

The object of the invention is to provide an article which is in itself serviceable as an attractive piece of furniture, yet at the same time constitutes a self-contained talking machine of superior quality.

Although cabineted talking machines have been known and used, yet the present invention is a marked improvement over all such prior machines known to the inventor, in utility and attractiveness of appearance as an article of furniture and without any sacrifice of acoustical properties as a talking machine, besides providing ready access for oiling or cleaning the mechanical parts, repairing them, etc.

Broadly stated, the invention comprises the combining of a graphophone in operative relation with a so-called library table, which latter may be defined as of inverted U-shape with flat top.

The invention comprises further the utilization of the two cubical portions of the library table, one beneath each end thereof, to support and give rigidity to the upper horizontally elongated casing

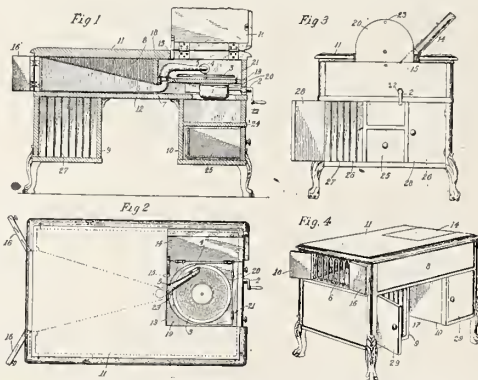

which contains the talking machine, and also to provide between themselves the knee space which adapts the article for use as a library table.

The invention comprises further the utilization to the fullest extent of the available spaces in said library table, for suitably locating the sound reproducing and sound conveying parts and the motor mechanism of the graphophone, and for storing a supply of sound records, etc.

The invention further comprises a movable support for the graphophone, for giving ready access to the sound reproducing parts and to the mechanism, for oiling, repairs or the like, while normally incasing and protecting said parts. And, finally, the invention comprises the combinations of the foregoing features and also the various details of construction, location and arrangement of the several parts, as hereinafter more particularly set forth and claimed.

In these drawings Fig. 1 is a vertical section, taken longitudinally through the cabineted graphophone; Fig. 2 is a plan view, the lid being open to expose the turntable of the graphophone; Fig. 3

is an elevation, viewed from one end of the table, the motor being represented as raised for inspection (from the other side); Fig. 4 is a perspective, viewed from the opposite end of the table.

GRAPHOPHONE AND TALKING MACHINE.—Karl A. Mauser, Leipzig, Germany, assignor to Polyphon-Musikwerke Aktiengesellschaft, of Wahren, near Leipzig, Germany. Patent No. 1,099,458.

This invention has reference to talking machines, phonographs, graphophones and the like, which are provided with a horn for the purpose of amplifying the sound. These sound amplifying horns occupy more space than the talking machine itself. If, however, the sound amplifying horn is located within the casing of the machine then the amplification of the sound is greatly reduced because the opening of the horn likewise must be greatly reduced to find room within the casing. These contrivances further have the disadvantage that the sound is strongly conveyed solely in the direction in which the horn is placed.

It is the purpose of the present invention to avoid the above described deficiencies and to produce a talking machine with a sound amplifier within the casing that conveys sound in all directions. This has been primarily attained by arranging the amplifying device within the casing so that its opening is at the top and by placing the motor or part of same within or before the opening of said amplifier.

Fig. 1 illustrates in side elevation partly in section a sound recording and reproducing device

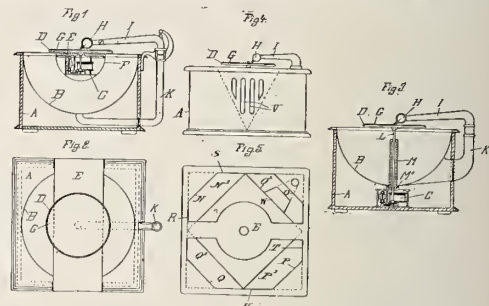

which embodies in desirable form the present improvements. Fig. 2 is a plan view of the same. Fig. 3 is an elevation partly in section of an apparatus in which the record support is shown to be arranged before the opening of an amplifier. Fig. 4 is a side elevation and Fig. 5 a top plan view showing a modified form of sound amplifying device.

PHONOGRAPH REPRODUCER.—Thomas A. Edison, Llewellyn Park, West Orange, N. J., assignor to New Jersey Patent Co., same place. Patent No. 1,099,346.

This invention relates to phonograph reproducers, and has for its object the provision of an improved mounting for the stylus lever in order that the same may have great freedom of movement in tracking the grooves of the sound record.

More particularly, the object of the invention is to provide a mounting for the stylus lever whereby the latter may rock in its own vertical plane about a pivot, as the stylus tracks the record groove while at the same time the lever may rock in a transverse direction to enable the stylus to follow the contour of the record groove with greater facility.

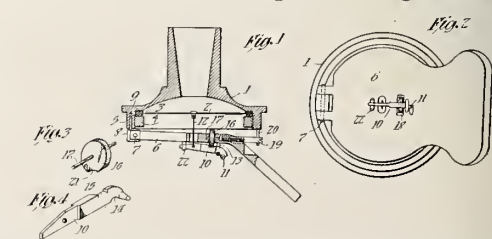

The requirement of great facility of movement of the stylus lever both in a direction parallel to and transverse to the record groove is particularly important in the case of a record having 200 threads or a greater number of threads per inch, owing to the thin walls between the record grooves which might be broken down or jumped across by a stylus, the parts moving with which have considerable inertia, and owing to the character of the record grooves generally. Accordingly, a member is provided which bears upon the

LATEST PATENTS RELATING TO TALKING MACHINES—(Continued from page 52).

upper surface of the stylus lever to constitute a fulcrum for the latter, the co-operating surfaces of the pivot member and the lever being so formed as to permit a limited rolling movement between the same in a plane transverse to the stylus lever. Preferably, the stylus lever is formed on its upper side with a convexed surface co-operating with the surface of the pivot member, which latter is preferably mounted for rotation to reduce friction.

Fig. 1 is a central vertical section through a reproducer equipped with the invention. Fig. 2 is a bottom view thereof, and Figs. 3 and 4 represent in perspective the rotatable pivot member and stylus lever adapted to coact therewith.

PHONOGRAPH REPRODUCER.—Thomas A. Edison, Llewellyn Park, West Orange, N. J., assignor to the New Jersey Patent Co., same place. Patent No. 1,099,347.

This invention relates to phonograph reproducers, and has for its object the provision of a mounting for the stylus lever and connections between the same and the diaphragm, whereby the stylus may have great freedom of movement in tracking the grooves of the record.

More particularly, the object of this invention is to provide a connection between the stylus lever and the diaphragm or other sound reproducing vibratory means, whereby the free movement of the stylus lever in a lateral direction while the stylus is tracking the record will not be impeded.

In the type of reproducer well known in the art, the tail of the stylus lever is connected to the center of the diaphragm by a link which is ordinarily a piece of wire which must have a certain amount of stiffness. When the stylus, in tracking the record groove, is caused to move laterally by the undulations thereof, the stylus lever can only swing in a lateral direction by bending or twisting the connecting link. This imposes resistance to the movement of the stylus lever, and likewise, the link is apt to be twisted or the diaphragm put under undesirable stress. This improvement is designed to obviate this by providing a connection between the tail of the stylus lever and the link, whereby the link will be allowed to maintain its vertical position during lateral movement of the stylus lever, while at the same time the up and down movement of the lever resulting from the tracking of the stylus over the bottom of the sound groove is transmitted unimpaired to the diaphragm. This is accomplished by means of a member interposed between the stylus lever and the link, which member is pivoted to swing in a lateral plane during lateral movement of the stylus lever. Preferably, this member is pivoted at one end upon a pin which occupies a vertical plane through the tail of the stylus lever, the member being connected at its other end to the lower end of the link.

The stylus lever is pivotally mounted in a manner to allow considerable freedom of movement

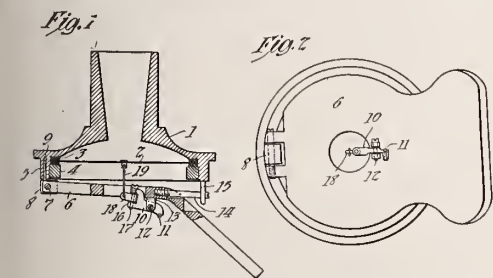

in a plane transverse to the record groove, whereby that facility of movement of the stylus lever which is particularly important in the case of the tracking of a record having 200 threads or a greater number of threads per inch is attained.

Fig. 1 is a central vertical section through a reproducer equipped with this invention, certain parts being shown in side elevation, and Fig. 2 is a bottom plan view thereof.

PHONOGRAPH REPRODUCER.—Thomas A. Edison, Llewellyn Park, West Orange, N. J., assignor to the New Jersey Patent Co., same place. Patent No. 1,099,348.

This invention relates to phonograph reproducers, and has for its objects the provision of

means whereby an improved volume and quality of reproduction may be obtained with the use of a floating weight of the same or less weight than that used at present, the weight being so mounted and constructed that the fulcrum of the stylus lever may be placed nearer to the stylus than would otherwise be possible without greatly increasing the weight imposed upon the stylus to hold it down to its work and consequently wearing the record to a degree which would be prohibitive in the case of records made of the usual compositions. By thus rendering possible an increased leverage for the stylus a greater amplification is obtained.

In the experiments, using a phonograph reproducer having the stylus lever pivoted in the usual manner from a floating weight pivoted in the manner well known in the art, the inventor attempted to increase the loudness of the reproduction by moving the pivoted point of the stylus lever nearer to the stylus, whereby the amount of amplification of the sound vibration should be increased, and consequently the loudness of the reproduction. On increasing the ratio of the leverage of the stylus lever beyond a certain point, however, it was found that the reproduction did not increase in volume because of the increased work imposed upon the stylus and the consequent tendency to lift the floating weight. To overcome this difficulty, a construction embodying the subject matter of this application was designed, in which the reaction of the pivot of the stylus lever due to the lifting of the stylus by the undulations of the record groove is exerted chiefly in a plane occupied by both the stylus lever pivot and the floating weight pivot, so that this thrust or reaction, being exerted against the immovable floating weight pivot, has but little tendency to lift the weight. The construction is such, however, that eccentricities in the record will lift the floating weight in order that the diaphragm shall not be affected by these irregularities.

In order that this invention may be more clearly understood, attention is hereby directed to the accompanying drawings, illustrating a preferred

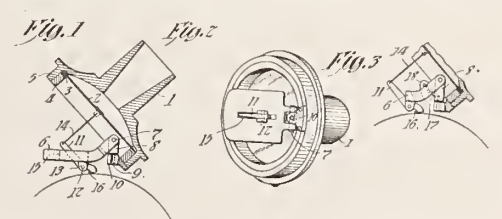

form thereof, in which Fig. 1 is a central vertical section through a reproducer equipped with the invention, certain parts being shown in side elevation. Fig. 2 is a bottom plan view thereof, and Fig. 3 is a partial sectional and elevational view similar to Fig. 1, illustrating a modification of the invention.

DICTAPHONE.—Thomas H. Macdonald (deceased), late of Bridgeport, Conn., by Sophie B. Macdonald, executrix, same place, assignor to the American Graphophone Co., same place. Patent No. 1,100,755.

This invention relates to graphophones or talking machines, primarily the type intended for both recording and reproducing and commonly known as "dictaphones" or "commercial machines," which type employs a single diaphragm with two styli (one for recording and the other for reproducing).

Heretofore it has been supposed that a reproducer should bear upon the record tablet with a pressure greater than that necessary or desirable in a recorder; therefore, with this end in view, various means have been provided whereby additional weight may be applied when the reproducing stylus is in operative engagement with the record groove, and removed when the recording stylus is in operative relation with the record tablet.

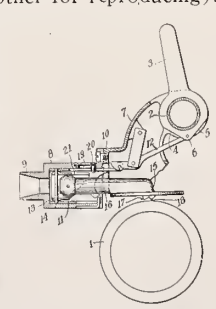

One feature of the present invention is the elimination of this additional weight or pressure. Another feature is the provision of improved means for preventing lateral play during the recording operation, while permitting lateral play during the reproducing operation.

In the drawing, 1 indicates the cylindrical sound record, or the blank cylinder, carried on the usual rotating mandrel.

NEEDLE CHANGING DEVICE.—Thomas H. Price and Harry R. Wheeldon, Lake Charles, La. Patent No. 1,100,910.

This invention relates to needle changing devices for graphophones and has for its object the production of an efficient automatic means whereby the needle may be automatically removed from the reproducer and another needle automatically replaced therefor.

Another object of this invention is the production of a needle magazine which may be attached

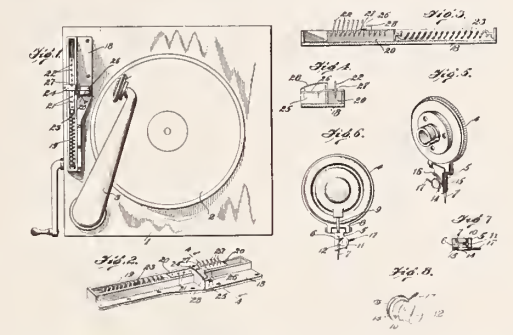

to any desired machine for the purpose of supplying needles to the reproducer.

Fig. 1 is a top plan view of the graphophone, showing the device applied thereto. Fig. 2 is a perspective view of the magazine applied to the graphophone. Fig. 3 is a longitudinal section of the magazine. Fig. 4 is a transverse section taken on line 4-4 of Fig. 2. Fig. 5 is a detail perspective of the needle carrying portion of the reproducer. Fig. 6 is a side view of the opposite side of the needle carrying portion of the reproducer. Fig. 7 is a transverse section taken through the needle engaging portion. Fig. 8 is a detail perspective of the needle retaining or engaging cam.

WRITES INTERESTING LETTER.

The Columbia Co. received this week another interesting epistle in praise of its dance product, this latest testimonial being sent by Prof. L. Lindenberg, a prominent dance instructor of Milwaukee, Wis., and foremost in many organizations devoted to the extension of dancing appreciations. Prof. Lindenberg writes as follows:

"Knowing that you are always pleased to learn of the success your machines give, I take great pleasure in expressing my entire satisfaction in your dance records. I use them on an average of fourteen hours per day and would not be without one for treble the price. The Columbia machine is a blessing to the dancing instructor, and I cannot see how anyone in this line can endeavor to get along without one. Cordially, (Signed) L. Lindenberg."

60 YEARS' EXPERIENCE

PATENTS

TRADE MARKS
DESIGNS
COPYRIGHTS & C.

Anyone sending a sketch and description may quickly ascertain our opinion free whether an invention is probably patentable. Communications strictly confidential. HANDBOOK on Patents sent free. Oldest agency for securing patents. Patents taken through Munn & Co. receive special notice, without charge, in the

Scientific American.

A handsomely illustrated weekly. Largest circulation of any scientific journal. Terms, \$3 a year; four months, \$1. Sold by all newsdealers.

MUNN & Co. 361 Broadway, New York
Branch Office, 625 F St., Washington, D. C.

RECORD BULLETINS FOR SEPTEMBER, 1914

VICTOR TALKING MACHINE CO.

No.	NEW DANCE RECORDS	Size.
17607	Bregeiro Tango—Maxixe (Ernesto Nazareth)	10
	Conrad's Society Orchestra	
	Mex e Remex—Maxixe (M. Sarrablo)	10
	Conrad's Society Orchestra	
35391	Come On Over Here—Combination One-step and Waltz Hesitation (Kollo-Christine)	12
	Conrad's Society Orchestra	
	Sur La Riviera—One-step (Including Le Long du Missouri) (Bertal-Ronn)	12
	Conrad's Society Orchestra	
35393	All He Does is Follow Them Around Medley—One-step	12
	Victor Military Band	
	Something Seems Tingle-Ing-Ing Medley—One-step, from "High Jinks"	12
	Victor Military Band	
17547	A Little Love, A Little Kiss—Waltz Hesitation (Un uel d'amour) (Lao Silsu) for dancing (60 bars per minute)	10
	Victor Military Band	
	Little Gray Home in the West—Waltz Hesitation (Hermann Lohr) For dancing (60 bars per minute)	10
	Victor Military Band	
17616	Old Cremorne—Waltz Hesitation (Le Vieux Jardin) (Gordon Davson) For dancing (60 bars per minute)	10
	Victor Military Band	
	Valse Noble Hesitation (Eugene C. Lesser) For dancing (60 bars per minute)	10
	Victor Military Band	
17615	By the Beautiful Sea Medley—One-step	10
	Victor Military Band	
	Sit Down, You're Rocking the Boat Medley—One-step	10
	Victor Military Band	
	POPULAR SONG LIST.	
17561	He's Working in the Movies Now (Williams-Bryan-Lodge)	10
	Billy Murray	
	They Don't Hesitate Any More (Pack-Kalmar-Leslie)	10
	Irving Kaufman	
17602	On the Shores of Italy (Al Piantadosi-Jack Glogau)	10
	Albert Campbell-Henry Burr	
	Harmony Bay (J. Brandon Walsh-Terry Sherman)	10
	Heidelberg Quintet	
17604	Kiss Me Again (I Like It) (Fleta Jan Brown)	10
	Helen Clark-Henry Burr	
	Where Can I Meet You To-night? (Farren-Lange)	10
	Ada Jones-Billy Murray	
17605	Don't Go Away (Milt Feiber-Jess-Feiber)	10
	Heidelberg Quintet	
	The 20th Century Rag (Clark-Leslie-Abrahams)	10
	Billy Murray	
17610	Eagle Rock, from "Passing Show of 1914" (Harold R. Atteridge-Harry Carroll)	10
	Collins and Harlan	
	My Croony Melody (E. P. Goetz-Joe Goodwin)	10
	Collins and Harlan	
	TWO RAG NUMBERS BY FELIX ARNDT.	
17608	Hacienda—The Society Tango (Paul Riese) (Piano Solo)	10
	Felix Arndt	
	Desecration Rag (A Classic Nightmare) (Piano Solo)	10
	Felix Arndt	
	TWO DESCRIPTIVE BAND NUMBERS.	
35392	Carovana Tripolina (A Passing Caravan in Tripoli) (Vessella)	12
	Vessella's Italian Band	
	Through the Panama Canal—Descriptive Fantasy (J. Louis von der Mebden, Jr.)	12
	Victor Military Band	
	TWO NUMBERS BY THE VAN EPS TRIO.	
17601	Chinese Picnic and Oriental Dance Medley—One-step	10
	Van Eps Trio	
	Notoriety Rag—One-step (Kathryn L. Widner)	10
	Van Eps Trio	
	NEW RECORDS OF TWO INSTRUMENTAL GEMS.	
35342	Träumerei (Reverie) (Schumann, Op. 15, No. 7) (Violoncello Solo with orch.) Rosario Bourdon	12
	Hearts and Flowers—Intermezzo (Tobani, Op. 245) (Violin-flute, cello-harp)	12
	Florentine Quartet	
	TWO NEW "SUMMER HITS" SONG MEDLEYS.	
35394	Gems from "Passing Show of 1914" (H. Atteridge-H. Carroll)	12
	Victor Light Opera Co.	
	Broadway Favorites	12
	Victor Light Opera Co.	
	BLUE LABEL RECORDS.	
55045	Aida—Celeste Aida (Heavenly Aida) (Act I) (Verdi) (Tenor Solo with orch.) In Italian.	12
	Paul Althouse	
	Ständchen (Serenade) (Schubert) (Tenor Solo with orch.) In German	12
	Paul Reimers	
60121	When It's Night-time Down in Burgundy (Alfred Bryan-Henman Paley). Baritone Solo	10
	George McFarlane	
70104	Same as His Father was Before Him (Terry Wells-Lauder) (Song)	12
	Harry Lauder	
	RED SEAL RECORDS.	
89081	La Traviata—Imponete (Now Command Me) (Act II) (Verdi) Soprano and Baritone Duet in Italian.	12
	Frieda Hempel and Pasquale Amato	
88480	La Paloma (The Dove). (Yradier) Soprano Solo in Spanish	12
	Lucrezia Bori	
88494	Warum? (Fantasietücke opus 12, No. 3 (Piano Solo) (R. Schumann)	12
	Ignace Jan Paderewski	
88460	Stabat Mater—Cupus animam (Through His Wounded Side) (Rossini) Tenor Solo	12
	Enrico Caruso	
88487	Tosca—Vissi d'arte e d'amore (Love and Music) (Act II) (Puccini) Soprano Solo in Italian.	12
	Emmy Destinn	
88489	Tosca—Te Deum (Finale Act I) (Puccini) Baritone Solo in Italian	12
	Pasquale Amato	
88484	Ave Maria (Schubert) Tenor Solo in English accomp. by Fritz Kreisler, violin and Vincent O'Brien on piano	12
	John McCormack	
74383	Liuba's Air, from "The Czar's Bride" ("Czar-skaia nevesta") (Rimsky-Korsakoff) Soprano solo in German	12
	Alma Gluck	
74403	Samson—Total Eclipse—"No Sun! No Moon!" (Handel) Tenor Solo in English. Evan Williams	12
	Violin accomp. by George Falkenstein on piano	12
	Maud Powell	
64410	Manon Lescaut—Donna non vidi mai (Never Did I Behold) (Act I) (Puccini) Tenor Solo in Italian	10
	Giovanni Martinelli	
64424	Who Knows? (Paul Lawrence Dunbar-Ernest R. Ball) Tenor Solo in English. J. McCormack	10

NEW EDUCATIONAL RECORDS.

We are this year celebrating the One Hundredth Birthday of "The Star Spangled Banner" Sept. 14, 1814-1914, and it is hoped that these records, made from the authorized version by band and chorus, may assist in making the celebration truly National.

17578	America (Dr. S. F. Smith-Henry Carey) (Arranged by the Music Section National Education Association)	10
	Victor Mixed Chorus	
	The Red, White and Blue (Timothy Dwight-David T. Shaw) (Arr. Music Section, N. E. Assoc.)	10
	Victor Mixed Chorus	
17579	The Star Spangled Banner (Francis Scott Key) (Arr. Music Section, N. E. Assoc.)	10
	Victor Mixed Chorus	
	Hail Columbia (Joseph Hopkinson-Prof. Phile) (Arr. Music Section, N. E. Assoc.)	10
	Victor Mixed Chorus	
17580	America (Henry Carey) (Arr. Music Section, N. E. Assoc.)	10
	Victor Military Band	
	The Red, White and Blue (David T. Shaw) (Arr. Music Section, N. E. Assoc.)	10
	Victor Military Band	
17581	The Star Spangled Banner (Francis Scott Key) (Arr. Music Section, N. E. Assoc.)	10
	Victor Military Band	
	Hail Columbia (Prof. Phile) (Arr. Music Section, N. E. Assoc.)	10
	Victor Military Band	
17583	Dixie—1. Banjo, tambourine, clappers; 2. Drum and piccolo; 3. Full band. Victory Mil. Band	10
	Yankee Doodle—1. Violin (as jig—old version); 2. Fife and drum; 3. Full band	10
	Victor Military Band	
17582	Battle Cry of Freedom (Geo. F. Root) (Revised version)	10
	Raymond Dixon	
	Song of a Thousand Years (Henry C. Work)	10
	Raymond Dixon	
	AMERICAN MUSIC HISTORY SERIES.	
17611	1. White Dog Song; 2. Grass Dance (Blackfeet Tribe)	10
	Glacier Park Indians	
	Medicine Song (Blackfeet Tribe)	10
	Glacier Park Indians	
	TWO FAMOUS HISTORICAL SPEECHES.	
35377	Lincoln's Gettysburg Address—delivered at the dedication of the Gettysburg Battlefield as a Soldiers' Cemetery, November, 1863.	12
	Harry E. Humphrey	
	Give Me Liberty, or Give Me Death!—Patrick Henry's Speech in the Virginia Convention of 1775.	12
	Harry E. Humphrey	
	MARCHES PLAYED FOR SCHOOL MARCHING.	
35389	The Stars and Stripes Forever March (John Philip Sousa)	12
	Arthur Pryor's Band	
	El Capitan March (John Philip Sousa)	12
	Arthur Pryor's Band	
17566	Hey Baloo (Burns-Schumann) from "Twenty Song Classics," C. C. Birchard & Co.	10
	Elsie Baker	
	The Little Dustman (Brahms) from "Twenty Song Classics," C. C. Birchard & Co.	10
	Elsie Baker	

COLUMBIA GRAPHOPHONE CO.

SYMPHONY DOUBLE DISC RECORDS.

A1555	Down in the Forest (Ronald) Soprano Solo, with orch. accomp. in English	10
	Margie Feyte	
	Believe Me If All Those Endearing Young Charms (Moore) Soprano Solo, orch. accomp. in English	10
	Maggi Teyte	
A5577	La Forza Del Destino (Verdi). "In This Solemn Hour," Tenor and Baritone Duet, orch. accomp. in English	12
	Morgan Kingstom and Louis Kreidler	
	Samson and Delilah (Saint-Saens). Samson's Prayer. Tenor Solo, orch. accomp. in English.	12
	Morgan Kingstom	
A5580	O Dolce Conento (Mozart-Dronet). Soprano Solo, orch. accomp. in Italian	12
	Bernice de Pasquali	
	Rigoletto (verdi). "Caro Nome" (Dearest Name). Soprano Solo, orch. accomp. in Italian	12
	Bernice de Pasquali	
	SYMPHONY SINGLE DISC RECORD.	
36908	Humoreske (Dvorak). Violin Solo.	12
	Eugen Ysaye	
A1558	Exhortation (A Negro Sermon) (Cook) Tenor Solo, orch. accomp.	10
	Reed Miller	
	Uncle Rome (Homer). Bass Solo, orch. accomp.	10
	Frank Croxton	
	DOUBLE-DISC RECORDS.	
A1544	Hello, Bill (Elk Song) (Heisler) Orch. accomp.	10
	Peerless Quartet	
	Auld Lang Syne	10
	Prince's Band	
A1554	Imitations of the Mocking Bird. Whistling Solo.	10
	Sherman Sherry Powell	
	Listening to the Mocking Bird (Winner). Whistling Solo, orch. accomp.	10
	Joe Belmont	
A1556	Threads of Gold (Fili d'Oro) (Buongiovanni)	10
	Berkes Bela Orchestra	
	Valse Conversation (Maxstatt)	10
	Berkes Bela Orchestra	
A1559	Medley of Sea Chanties (Smith). Orch. accomp.	10
	Peerless Quartet	
	Medley of Reels, Jigs and Hornpipes (Arr. by Smith.) Violin, with orch. accomp.	10
	Walter Biedermann	
A1560	Autumn Dreams (Valse Brillante) (Zimmerman). Trombone Solo, band accomp.	10
	Leo Zimmerman	
	Twinkling Star Polka (Smith). Piccolo and xylophone, orch. accomp.	10
	Marshall Lufsky and Howard Kopp	
A5578	Unlucky Mose. Vaudeville sketch	12
	Billy Golden and Joe Hughes	
	I'se Gwine Back to Arkansas. Vaudeville sketch.	12
	Billy Golden and Joe Hughes	
S7518	Violet Mazurka from the "Wildflower Suite" (Hager)	12
	Prince's Band	
	Golden Rod Galop, from the "Wildflower Suite," (Hager)	12
	Prince's Band	
	DANCE HITS OF THE MONTH.	
	Recording Supervised by G. Hepburn Wilson.	
A5579	Brazilian Dreams (Dixon). Maxixe	12
	Prince's Band	

	Too Much Ginger (Daly). One-step	12
	Prince's Band	
A5581	Mona Lisa (Platzmann). Hesitation Waltz	12
	Prince's Band	
	Rose of the Mountain Trail (Caddigan and Brennan). One-step	12
	Prince's Band	
A5582	By the Beautiful Sea (Carroll). One-step	12
	Prince's Band	
	That's a Plenty (Pollack). One-step	12
	Prince's Band	
A5583	Jungle Jambouree (Smith). One-step. Violin and piano duet.	12
	Albert and Monroe Jockers	
	Dorothy Waltzes (Rodenbeck). Violin and piano duet.	12
	Albert and Monroe Jockers	
A5584	Cecile (McKee). Hesitation Waltz	12
	Prince's Band	
	On with the Dance (Smith). Hesitation-Waltz-Trot	12
	Prince's Band	
	SONG HITS.	
A1557	You're Here and I'm Here (Kern) Baritone Solo, orch. accomp.	10
	Ed. Morton	
	The Walla Walla Man (Bennett). Orch. accomp.	10
	Peerless Quartet	
A1561	Just for To-night (Cobb). Contralto Solo, orch. accomp.	10
	Clara Morster and Peerless Quartet	
	Rose of the Glen (Costello and Helf) Counter-tenor solo, orch. accomp.	10
	Manuel Komain	
A1562	If I Had You (Berlin). Tenor Solo, orch. accomp.	10
	Henry Burr	
	When Did You Write to Mother Last? (Harris) Tenor Solo, orch. accomp.	10
	Henry Burr	
A1563	All He Does Is Follow Them Around (Abrahams). Baritone Solo, orch. accomp.	10
	William Halley	
	By the Beautiful Sea (Carroll). Soprano and Tenor Duet, orch. accomp.	10
	Ada Jones and Billy Watkins	
A1564	Don't Go Away (Feiber). Orch. accomp.	10
	Peerless Quartet	
	Some Day You'll Know Who Loves You (Bennett). Contralto Solo, orch. accomp.	10
	Elida Morris	
A1565	They're On Their Way to Mexico (Berlin). Baritone Solo, orch. accomp.	10
	William Halley	
	He Was Always Fooling Around (Jerome-Greenberg) Baritone Solo, orch. accomp.	10
	William Halley	

THOMAS A. EDISON, INC.

CONCERT LIST.

28197	Trovatore—Miserere (Verdi) Soprano and Tenor Duet, orch. accomp.	12
	Anna Case, Paul Althouse and Male Chorus	
28198	Martha—None so rare (M'appari) (Flotow) Tenor Solo, orch. accomp.	12
	Paul Althouse	
28199	Pescatori di Perle—Mi par d'udir ancora (Bizet) Tenor Solo in Italian	12
	Aristodemo Giorgini	
	REGULAR LIST.	
2385	Aeroplane Dip—Waltz Hesitation (Arthur Pryor) For dancing	10
	National Promenade Band	
2386	Mary, You're a Little Bit Old-Fashioned (Marshall) Tenor, orch. accomp.	10
	Walter Van Brunt	
2387	Recessional (Kipling—de Koven) Sacred, orch. accomp.	10
	Edison Mixed Quartet	
2388	The Rose of the Mountain Trail (Vocal obligato by Clementine de Vere) (Brennan) Baritone Solo, orch. accomp.	10
	Vernon Archibald	
2389	Grand Valse de Concert (Mattei) Reed only	10
	Edison Concert Band	
2390	Everybody Loves My Girl (Ayer) Tenor Solo, orch. accomp.	10
	Irving Kaufman	
2391	If They'd Only Move Old Ireland Over Here (Frank Gillen) Tenor Solo, orch. accomp.	10
	Edward M. Favor and Chorus	
2392	All on Account of You (Solman) Tenor Solo, orch. accomp.	10
	Irving Gillette	
2393	Hearts and Flowers (Tobani)	10
	Venetian Instrumental Quartet	
2394	'Twas in September—The Beauty Shop (Hein) Conversational duet, orch. accomp.	10
	Ada Jones and Billy Murray	
2395	When You Play in the Game of Love (Piantadosi) Tenor Solo, orch. accomp.	10
	Manuel Romain	
2396	The Blue Jay and the Thrush (Belmont) Singing and whistling, orch. accomp.	10
	Harlan and Belmont	
2397	This is the Life Medley—Turkey Trot. For dancing	10
	National Promenade Band	
2398	In the Palace of Dreams (Friedman) Contralto and Tenor Duet, orch. accomp.	10
	Helen Clark and Emory B. Randolph	
2399	Kentucky Babe (Geibel) Male voices, orch. accomp.	10
	Manhattan Quartet	
2400	Lorena (Webster) Mixed voices, orch. accomp.	10
	Metropolitan Quartet	
2401	The Dorothy Three-Step (Lampe) For dancing. National Promenade Band	10
	National Promenade Band	
2402	Over the Alpine Mountains (Fischer) Tenor duet, orch. accomp.	10
	A. H. Campbell and I. Gillette	
2403	The Wanderer (Schubert) Bass, orch. accomp.	10
	Frederic Martin	
2404	Something Seems Tingle-ingleing—High Jinks (Friml) Tenor Solo, orch. accomp.	10
	W. Van Brunt	
2405	Humoreske (Dvorak) Violin Solo, piano accomp.	10
	Samuel Gardner	
2406	He'd Push It Along (Abrahams) Comic song, orch. accomp.	10
	Edward Meeker	
2407	Castle House Rag One-Step (Europe) for dancing	10
	National Promenade Band	
2408	Mooching Along (Muir) Orch. accomp.	10
	Arthur Collins and Byron G. Harlan	
2409	Bedtime at the Zoo (Monckton) Comic Song, orch. accomp.	10
	Ada Jones	

\$ \$ \$ \$ \$ \$ \$ \$ \$

\$ \$ \$

\$ \$ \$

\$ \$ \$

\$ \$ \$

\$ \$ \$

READ your trade paper! Get The Talking Machine World regularly—It is worth many times to you its annual cost.

There is but one talking machine paper covering this entire industry, and it is admitted by all that it is of great aid to the dealers in every part of this country.

New economic conditions make certain knowledge necessary on the part of merchants, and in every issue of The World there is contained educational matter, instructive service, business news and technical articles which are worth many times the cost of the paper.

Thousands have been benefited by the business articles which appear in The World, and every talking machine dealer should receive it regularly.

The only way to do that is to pay for it, and the cost is trifling—a little over eight cents a month, and for that small sum The World, with all its mine of information, is at your service.

If you do not receive the paper regularly, just put your dollar in an envelope and address it to the office of the publication, and you will say that it is the best investment that you have ever made.

Do not delay but send on your dollar now.

Recollect that your competitor is getting The World—getting it regularly, and in it he is securing some valuable pointers—information which places you at a disadvantage if you do not read the paper.

Do not overlook such a valuable contributing factor to your business success.

EDWARD LYMAN BILL

PUBLISHER

373 Fourth Avenue,

New York City

“Tell him what he
wants to hear”

“Sell him what he
wants to buy”

These two basic selling rules
were old when the world
was young. You use them
with the utmost freedom in
selling the full Edison Line
because of its tremendous
variety of talking points.

No matter what your cus-
tomer's tastes, you can
always find some Edison
superiority he's been wanting
to hear about and so you
can *always* sell him what
he wants to buy.



Edison Disc and Cylinder Phonographs



Thomas A Edison
INCORPORATED

59 Lakeside Ave., ORANGE, N. J.

The TALKING MACHINE WORLD

AND
NOVELTY
NEWS

Published Each Month by Edward Lyman Bill at 373 Fourth Avenue, New York, September 15, 1914



Victrola XVI, \$200
Mahogany or oak

The instrument by which the value of
all musical instruments is measured



DEATH TO STEEL NEEDLES

THE SONORA JEWEL MULTI-PLAYING NEEDLE
A RELIABLE and IMPROVED SUBSTITUTE

MARKS

The Beginning of the End of the Steel Needle

BECAUSE IT

**Eliminates the necessity of changing after each playing,
Plays on all makes of disc phonographs,
Improves on the tone-quality of the record,
Reduces to a minimum the scratch and any imperfections which may exist,
Increases the life of the record,
Gives new life to used records,
Permits different tone volumes without the aid of other attachments, and
Is guaranteed for three months.**

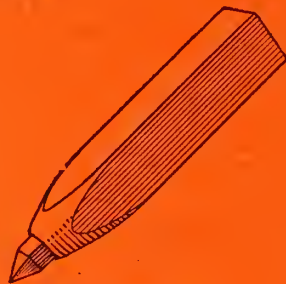

PATENTS PENDING.

PRICE, \$1.00

Five years ago the Sonora Phonograph Co. introduced the first perpetual Jewel Disc Record made in the United States. Since that time, by continual efforts, wonderful improvements have been made. Encouraged by the success of this record and the needle used thereon, and realizing the trouble, annoyance and damage which the use of steel needles causes to disc records, we have now perfected this Jewel Needle, which eliminates the necessity of changing after every record and still does not injure the delicate grooves of the record, as the use of the steel needle does, and at the same time greatly improves on the tone.

All owners of talking machines dislike the requirement of changing the needle after each playing and the SONORA JEWEL MULTI-PLAYING NEEDLE will be welcomed by them all.

Every owner of a talking machine will want one or more of these needles, and with the SONORA JEWEL MULTI-PLAYING NEEDLE it will be "Once a User, Always a User."

We want dealers in every city to handle this needle. Be first in introducing it in your city and have the advantage over your competitors. Exclusive representation granted.

Write for descriptive circular, also new catalogue of phonographs and prices to

SONORA PHONOGRAPH CORPORATION, Mfrs.

57 READE STREET, NEW YORK

GEO. E. BRIGHTSON, Pres.

(The attention of our Legal Department will be called to any individual, firm or corporation wilfully making false statements regarding the merits of this needle.)

The Talking Machine World

Vol. 10. No. 9.

New York, September 15, 1914.

Price Ten Cents

NEW USE FOR TALKING MACHINE.

Humanitarian of St. Louis Uses Victrola for Entertainment of Homeless Cats and Dogs and Demonstrates Plan for Reporter.

(Special to The Talking Machine World.)

St. Louis, Mo., September 8.—Miss Lillie Nagel, a practical humanitarian of this city, has found a new use for a talking machine. The newspaper printing her interview called it a Victrola, and so it must have been that machine.

Miss Nagel is locally famous as conducting a home for stray dogs and cats in the best residence district of the city. All of the neighbors know that if a stray bothers them the place to send it is to Miss Nagel's home, where it is fed and doctored until in fine condition, when she finds a home for it. Recently she was named in a trust deed to superintend the construction of a dog and cat charity hospital. A newspaper reporter went out to learn of her plans, and he found Miss Nagel enthusiastic over the discovery that cats and dogs appreciated music.

"Isn't it fine that I have made this discovery just as we are going to build the hospital?" she exclaimed, "for we will have a music room in the new building and to it will come the cats and dogs for enjoyment as their favorite numbers are played, for they all do not like the same sort of music."

Then Miss Nagel took the reporter into the house and put on a Caruso record to show that some of the forty or more stray dogs on the premises would dance to it and otherwise show their appreciation. Next she put on some soft and low music and called attention to other cats and dogs. A third trial was for ragtime, and some other animals showed their appreciation sufficient to convince Miss Nagel, if not the reporter, that they liked the tune. Then she explained the plans for the music room in the hospital. Now all live talking machine dealers can advertise their wares for cats' and dogs' entertainment and refer to Miss Nagel.

THAT BAD CHECK GAME AGAIN.

Ray Bros., Louisville, Ky., Nearly Lose \$300 Victor Outfit on Bad Check Transaction.

(Special to The Talking Machine World.)

LOUISVILLE, Ky., September 8.—Ray Bros., who handle a large Victor business here, had a narrow escape from being swindled on a bad check last week. A man visited the company's store and selected a \$250 Victrola and about \$50 worth of records, for which he tendered a check that he had made out in the presence of the clerk. He advised that the bank be communicated with in order to establish the value of the check, and that fact drew the salesman off his guard. The bank was called up, however, before the goods were shipped and the check was declared no good. It was learned that the man with the check was somewhat irrational and had made a practice of distributing worthless checks among tradesmen apparently without a desire to profit by the scheme.

BEN L. BROWN NOW MANAGER.

Ben L. Brown, formerly assistant manager of the Cincinnati store of the Columbia Graphophone Co., has been promoted to the management of the Louisville, Ky., store of that company, succeeding D. S. Ramsdell, and took up his new duties on September 1.

ENLARGES VICTOR DEPARTMENT.

The West Music House, one of the oldest music houses in Joliet, Ill., has recently remodeled its quarters to make room for new demonstrating booths in the Victor talking machine department.

TWENTY-FIVE YEARS OF SERVICE.

Mr. and Mrs. Frank Dorian Guests of Honor at Dinner Given by Mr. and Mrs. Easton to Celebrate Mr. Dorian's 25th Year of Service with the Columbia Graphophone Co.

Mr. and Mrs. Frank Dorian were the guests of honor at a dinner given on September 3 at the Arcola Country Club, Arcola, N. J., by Mr. and Mrs. Edward D. Easton to celebrate the completion of Mr. Dorian's twenty-fifth year in the service of the Columbia Graphophone Co. Others present at the dinner were George W. Lyle, general manager of the Columbia Co.; Mr. and Mrs. C. W. Woddrop and Mr. and Mrs. Mortimer D. Easton.



Frank Dorian.

Mr. Dorian entered the service of the company as a lad of nineteen in Washington, D. C. He was at that time a typewriter operator of extraordinary ability. He served for some years in minor capacities, afterwards became private secretary to Mr. Easton, then Baltimore manager, Washington manager and later general manager of the company, from which position he was in 1897 transferred to Europe as the general manager of the company's business there. He had his headquarters for three years in Paris and for nine years in London and then returned to the United States and took charge of the Dictaphone, of which he is now manager. He has been signally successful in all his undertakings and has a host of friends throughout the world who admire his personality, business acumen and sterling character.

In view of Mr. Dorian's youthful appearance it is hard for his friends to realize that, with the exception of President Easton, he is the oldest living employe in continuous service with the Columbia Graphophone Co.

NEW DEPARTMENT FOR MILWAUKEE.

Victrola Section to Be Feature of New Building Now Being Erected by Edward Schuster & Co.'s Great Department House in That City.

(Special to The Talking Machine World.)

MILWAUKEE, Wis., September 8.—Edward Schuster & Co., operating large and successful department stores at Third and Garfield and Twelfth and Vliet streets, will install a Victor talking machine department in the new department store which it is erecting on the south side, and which will be opened some time in October. The Schuster concern has met with such success in handling the Victor line at its two present stores that it made arrangements several months ago to carry the line at its new store. The company recently installed piano departments in its stores, which are in charge of Mr. Marks, formerly well known in St. Louis.

W. E. DEWELL MAKES A CHANGE.

W. E. Dewell, who established and for some time was manager of the successful Edison phonograph department of Martin & Co., Sioux City, Iowa, recently severed that connection to take charge of the phonograph sales department of the Huse Publishing Co., Norfolk, Neb.

PROMOTED TO MANAGER.

Walter G. Young, a salesman in the Victrola department of the Stewart Dry Goods Co. store, Louisville, Ky., has been appointed manager of the department, to succeed L. M. Knickerbocker.

The man who is on the winning side is most apt to preach the triumph of right.

ACQUIRES MUSICAL KNOWLEDGE.

How the Talking Machine Has Brought Opera and the Best Class of Music Into the Homes of the Every Day People in the Country as Well as City—"Ain't No More Country."

It has well been said that there is no longer any "country." In other words, country folks have become so civilized, so up-to-date with their automobiles, their telephones and talking machines and latest styles of dress, that the old time distinctions between the people of the city and country are gradually diminishing.

Through the medium of the talking machine all the latest music now finds its way into the homes of the farmers, and they discuss the latest operas with as much interest as if they had seen and heard them. All of this makes for culture and progress, and it shows what an uplifting factor is the talking machine. This apropos the following clipping, which we take from the "Office Window" department of the Evening Mail:

"A little girl of five or six years, out at Tuckahoe, astonished a company of people the other day by singing several operatic selections as she played about the floor. Perfectly unconscious, she warbled the most complicated airs with her almost baby voice, accompanying them with a queer jumble of words, which were a sort of childish reflection of the words that really belong to them. "Why, the child is singing grand opera!" someone exclaimed. But why should she not sing grand opera? She had heard it on the phonograph ever since she was born. Possessing a musical ear and a voice as a gift of nature, the oft-repeated songs of the phonograph had easily effected a lodgment in her memory, and she sang them as a matter of course.

"Probably there are many children like her. The Office Window man has heard a farm boy, away up in Vermont, whistling operatic airs with great fluency. They had come to his ears, too, through the little machine that nightly filled the home sitting room with its thin, metallic notes. Now and then a child is born with a talent for music. Such a child will pick up opera from a phonograph as readily as it picks up the ordinary phrases of speech from its companions.

"What will be the effect of the phonograph on the musical cultivation of the American people? Undoubtedly it will spread the knowledge of the mechanism of music. It will take time to tell whether it will increase the musical taste of the people, upon which, and upon which only, a real national music must be founded."

CO-OPERATING WITH MANUFACTURER

A clean shaven, quiet looking fellow standing on the outskirts of the gathering when the discussion started, worked his way in and said every month his store sent out at least 3,000 distinctive circulars; these were in addition to statements and invoices. There is not a week that goes by that he does not get some returns from circulars sent out in the manner described. The circulars cost one cent each. The talking machine dealer who does not take advantage of the manufacturer's advertising matter sent out is certainly slow. They advertise the things that customers want to know about. If the circulars are short and pithy, and get into the hands of the ladies, they will bring results.

MILWAUKEE HOUSE CHANGES NAME.

(Special to The Talking Machine World.)

MILWAUKEE, Wis., September 8.—The Hoeffler Manufacturing Co., 306 West Water street, which has maintained a large and flourishing Victor department for several years and has carried on a large business in a general line of automatic musical instruments, has filed an amendment to its articles of incorporation, changing its name to the Hoeffler Piano Co. The Hoeffler house took up the agency for a well-known line of pianos about the first of the year.

FALL TRADE OPENING UP WELL IN MILWAUKEE.

War Disturbance Has Little Effect on Business in That City, Is Report—Dealers Ordering Very Freely as Result of Good Crop Outlook—Anti-Tuberculosis Association Wants Records—Badger Talking Machine Co. Succeeds—General Trade News of Interest.

(Special to The Talking Machine World.)

MILWAUKEE, Wis., September 8.—The disquieting effect of the European war does not seem to be having any adverse influence on the talking machine business in Milwaukee or about Wisconsin. Jobbers and dealers say that the fall trade is opening up very satisfactorily and that there is every indication of a good business being received from now until after the holiday season.

The fact of the matter is that the war is doing much to improve general business in Milwaukee, and this is reacting with favor upon the talking machine trade. Milwaukee and Wisconsin manufacturers recently held a big meeting in Milwaukee to discuss the possibilities of an increased export trade, especially in South America, now that Germany is forced to withdraw some of her attentions from that country. A committee was appointed and general plans made to further the export trade in South America. The result has been that there has been increased activity in many lines.

Jobbers say that dealers about the State have been ordering rather freely in both machines and records. Stocks in dealers' hands have not been large during the summer, and now it is necessary to order for the fall trade. Conditions about the State are especially favorable at this time. A bumper grain crop has been threshed and is being sold at record-breaking prices, resulting from the European war, and the outlook for the corn crop was never better. Farmers and dealers in the smaller cities and towns about the State seem to be prosperous, and this ought to result in a good business.

Appeal for Used Records.

The Wisconsin Anti-Tuberculosis Association, with headquarters in Milwaukee, has appealed to the citizens of Milwaukee to donate any old talking machine records which they may have to the patients of the Milwaukee County Tuberculosis Sanatorium. A. G. Kunde, well-known Columbia jobber and dealer, 615 Grand avenue, won public approval some months ago by presenting the tuberculosis patients with a Columbia machine after a portion of the sanatorium had been destroyed by fire and the only available talking machine had been lost. Only a few records are owned by the institution, however, and the board of trustees of the sanatorium cannot well afford to spend money at this time for new records, so the Anti-Tuberculosis Association suggests that a gift of records would do much to brighten the existence of the inmates.

Mrs. J. H. Becker on Road to Recovery.

Mrs. J. H. Becker, wife of the enterprising manager of the Victor department of the Hoeffler Piano Co., 306-308 West Water street, is slowly recovering from the effects of a serious operation recently performed at one of the Milwaukee hospitals. Mrs. Becker has been ill for more than a month and her life was despaired of at one time.

Record Sales Unusually Good.

Record sales at the Hoeffler Piano Co.'s store have been unusually good of late, largely as a result of an interesting advertising and publicity campaign conducted by J. H. Becker, Jr., manager of the Victor department at the store. Mr. Becker arranged a large number of attractive show cards for his windows, made up of the title pages from the sheet music of various record selections, on which was printed the number of the particular record carrying the piece in question. This scheme did much to increase record sales, aided by the plan of printing some of the leading record titles on the outside of the regular mailing list envelopes. Mr. Becker reports that since the European war began the sale of the Victor record, "Die Wacht Am Rhine," No. 16,423, has attained a new high mark. This is not to be wondered at, in view of our large German population.

Visitors from Chicago.

Roy J. Keith and D. C. Prescott, both of the Talking Machine Co., of Chicago, recently called upon the Milwaukee trade. Both were optimistic regarding the fall outlook.

H. R. Fitzpatrick to Travel for Victor Co.

Wisconsin talking machine dealers are well pleased over the fact that Harry R. Fitzpatrick, who served for several years as manager of the Wisconsin Talking Machine Co., the predecessor of the Badger Talking Machine Co., Victor jobber in Milwaukee and Wisconsin, has been appointed traveling representative of the Victor Talking Machine Co. in Wisconsin, Illinois and northern Michigan, succeeding S. W. Goldsmith, vice-president of the Badger Talking Machine Co., who traveled over this territory for eight years. Mr. Fitzpatrick made a host of friends among Wisconsin dealers while engaged in the jobbing business who are wishing him success in his new position. Mr. Fitzpatrick formerly traveled for the Victor Co. before coming to Milwaukee several years ago. He will make his headquarters in Milwaukee.

Large Types of Machines in Demand.

Paul A. Seeger, manager of the Victor depart-

ment of the Edmund Gram Piano House, reports that the demand for the large type of Victrolas is unusually good at this time. Mr. Seeger and his family recently returned from a three weeks' vacation spent at Sister Bay, Wis.

H. H. Schwenker, traveling repair man of the Victor Talking Machine Co., spent a few days in Milwaukee recently, making his headquarters at the office and warerooms of the Badger Talking Machine Co., jobbers in Wisconsin and upper Michigan for the Victor line.

New Concern Starts Off Well.

The new Badger Talking Machine Co., successor to the Wisconsin Talking Machine Co. as jobber in Wisconsin and northern Michigan for the Victor line, experienced an unusually good business during the first month of its existence. Both S. W. Goldsmith, vice-president, and Harry A. Goldsmith, secretary-treasurer, report that the outlook is bright for a big fall trade.

"Wisconsin dealers are buying exceptionally well," said S. W. Goldsmith, "and I am confident that the Victor will meet with a big business in this State this fall. We have located several new Victor dealers in our territory during the past month. I have just returned from a business trip to Minneapolis and St. Paul, and conditions in the Northwest are favorable."

George F. Ruez, president of the Badger Talking Machine Co., has moved to Milwaukee from Ishpeming, Mich., and will now devote his entire time to the jobbing business.

F. H. Hochmuth in New Quarters.

F. H. Hochmuth, one of Milwaukee's well-known music dealers, who has been engaged in business at 311 Chestnut street for many years, moved into a handsome new building at 347 Third street soon after September 1, where he has broadened his business in several lines. Mr. Hochmuth has secured the retail agency for the Victor line of goods and is displaying them in specially arranged quarters in his new building. A new piano department has also been installed.

New Edison Disc Dealers.

Several Edison disc dealers have been placed in Wisconsin and northern Michigan during the past month, according to William A. Schmidt, general manager of the Phonograph Co., of Milwaukee, jobber in this territory for the Edison line. Good retail sales are being made at the Edison Shop, 213-215 Second street.

To Move Into New Quarters.

A. G. Kunde, Columbia jobber and retailer, 615 Grand avenue, hopes to be able to move into his new quarters at the new Miller building at the corner of Grand avenue and Fifth street by September 15. The new structure has been erected on the site of the building formerly occupied by Mr. Kunde, who will have his former address, 516 Grand avenue.

The Success of Your Talking Machine Department

Is to a *large* extent dependent upon the service your distributor gives you.
This admitted makes it important that you secure the best service obtainable.

AND THAT IS EASTERN SERVICE

To use it is to swear *By* it not *At* it.

May we not have the opportunity to convince you that our service is exceptional?

EASTERN TALKING MACHINE COMPANY

177 TREMONT STREET, BOSTON, MASS.

EDISON

FOR NINETEEN YEARS TALKING MACHINES EXCLUSIVELY

VICTOR



Victrola X, \$75
Mahogany or oak



Victrola IV, \$15
Oak



Victrola VIII, \$40
Oak



Victrola XVI, \$200
Mahogany or oak

Success in the music trade is measured by the Victrola.

The dealers who are the most successful are those who make the most of the opportunities the Victrola offers them.

Victor Talking Machine Co., Camden, N. J., U. S. A.

Berliner Gramophone Co., Montreal, Canadian Distributors.

Always use Victor Machines with Victor Records and Victor Needles—the combination. There is no other way to get the unequalled Victor tone.



Victor Distributors

Albany, N. Y.....	Finch & Hahn.	Detroit, Mich.....	Grinnell Bros.	Omaha, Neb.....	Nebraska Cycle Co.
Altoona, Pa.....	W. F. Frederick Piano Co.	Elmira, N. Y.....	Elmira Arms Co.		A. Hospe Company.
Atlanta, Ga.....	Elyea-Austell Co.	El Paso, Tex.....	W. G. Walz Co.	Peoria, Ill.....	Putnam-Page Co., Inc.
	Phillips & Crew Co.	Galveston, Tex.....	Thos. Goggan & Bros.	Philadelphia, Pa.....	Louis Buehn.
Austin, Tex.....	The Talking Machine Co., of Texas.	Honolulu, T. H.....	Bergstrom Music Co., Ltd.		C. J. Hepe & Son.
Baltimore, Md.....	Cohen & Hughes, Inc.	Indianapolis, Ind.....	Stewart Talking Machine Co.		Penn. Phonograph Co., Inc.
	E. F. Droop & Sons Co.	Jacksonville, Fla.....	Florida Talking Machine Co.		The Talking Machine Co.
	H. R. Eisenbrandt Sons.	Kansas City, Mo.....	J. W. Jenkins Sons Music Co.		H. A. Weymann & Son, Inc.
Bangor, Me.....	Andrews Music House Co.		Schmelzer Arms Co.	Pittsburgh, Pa.....	C. C. Mellor Co., Ltd.
Birmingham, Ala.....	Talking Machine Co.	Lincoln, Neb.....	Ross P. Curtice Co.		Standard Talking Machine Co.
Boston, Mass.....	Oliver Ditson Co.	Little Rock, Ark.....	O. K. Houck Piano Co.	Portland, Me.....	Cressey & Allen, Inc.
	The Eastern Talking Machine Co.	Los Angeles, Cal.....	Sherman, Clay & Co.	Portland, Ore.....	Sherman, Clay & Co.
	M. Steinert & Sons Co.	Louisville, Ky.....	Montenegro-Riehm Music Co.	Richmond, Va.....	The Corley Co., Inc.
Brooklyn, N. Y.....	American Talking Machine Co.	Memphis, Tenn.....	O. K. Houck Piano Co.		W. D. Moyses & Co.
Buffalo, N. Y.....	W. D. Andrews	Millwaukee, Wis.....	Badger Talking Machine Co.	Rochester, N. Y.....	E. J. Chapman.
	Neal, Clark & Neal Co.	Moble, Ala.....	Wm. H. Reynolds.		The Talking Machine Co.
Burlington, Vt.....	American Phonograph Co.	Montreal, Can.....	Berliner Gramophone Co., Ltd.	Salt Lake City, Utah.....	Consolidated Music Co.
Butte, Mont.....	Orton Brothers.	Nashville, Tenn.....	O. K. Houck Piano Co.	San Antonio, Tex.....	Thos. Goggan & Bros.
Chicago, Ill.....	Lyon & Healy.	Newark, N. J.....	Price Talking Machine Co.	San Francisco, Cal.....	Sherman, Clay & Co.
	The Talking Machine Co.	New Haven, Conn.....	Henry Horton.	Savannah, Ga.....	Phillips & Crew Co.
	The Rudolph Wurlitzer Co.	New Orleans, La.....	Philip Werlein, Ltd.	Seattle, Wash.....	Sherman, Clay & Co.
Cincinnati, O.....	The Rudolph Wurlitzer Co.	New York, N. Y.....	Blackman Talking Machine Co.	Sioux Falls, S. D.....	Talking Machine Exchange.
Cleveland, O.....	The W. H. Buescher & Sons Co.		Emanuel Blout.	Spokane, Wash.....	Sherman, Clay & Co.
	The Collister & Sayle Co.		C. Bruno & Son, Inc.	St. Louis, Mo.....	The Aeolian Company of Mo.
	The Eclipse Musical Co.		I. Davega, Jr., Inc.		Koerber-Brenner Music Co.
Columbus, O.....	Perry B. Whitsit Co.		S. B. Davega Co.	St. Paul, Minn.....	W. J. Dyer & Bro.
Dallas, Tex.....	Sanger Bros.		Chas. H. Ditson & Co.	Syracuse, N. Y.....	W. D. Andrews Co.
Denver, Colo.....	The Hext Music Co.		Landay Brothers, Inc.	Toledo, O.....	The Whitney & Carrier Co.
	The Knight-Campbell Music Co.		New York Talking Machine Co.	Washington, D. C.....	Robert C. Rogers Co.
Des Moines, Ia.....	Chase & West Talking Mach. Co.		Ormes Inc.		E. F. Droop & Sons.
	Mickel Bros Co.		Silas E. Pearsall Co.		
			Benj. Switky.		
			J. B. Greenhut Company, Inc.		

FAMOUS RECORD ALBUMS

AT VERY LOW PRICES TO MEET COMPETITION

These Record Albums will Pay for Themselves in a short Time by Preserving Records. When Full the Albums are Flat and Even Like Books. They will Fit in a Library Cabinet or Book Case, or They will Lie Flat on One Another.

For Durability, Artistic Design and Finish, our Albums have no equal. They are made in the most substantial manner by skilled workman. We sell our Superb Albums at big discounts to meet competition. Shall we send samples and quote our very low prices?



DISC RECORD ALBUMS
ARE WHAT EVERY
Talking Machine Owner
MUST NOW HAVE

With the index they make a complete system for filing away all disc Records, and can be added to, Album by Album, as Records accumulate, like books in a library.

THESE ALBUMS ARE THE BEST FOR VICTOR, EDISON, COLUMBIA AND ALL OTHER DISC RECORDS

Write for samples of our Albums, which are superior to all others

Address NATIONAL PUBLISHING CO., 235 South American St., Philadelphia, Pa.

FALL TRADE STARTS IN CINCINNATI.

Dealers Generally in Optimistic Mood—Victrola Department of Cable Company Opened to the Public—Steubenville Dealer in Trouble—Liberal Advertising the Rule—What the Managers Report Anent Conditions.

(Special to The Talking Machine World.)

CINCINNATI, O., September 9.—From all appearances Cincinnati is no worse off than the other important communities of the United States. There is a most optimistic feeling among the managers of the various talking machine departments about the city. In a general way they feel that the business for this month will off-set the losses of July and August. There was just a fair amount of business during these two months. More than the average number of Cincinnatians appeared to have been away during the past sixty days. Now one again hears the music of the talking machines.

After much delay the Victrola department of the Cable Company, on West Fourth street, will be thrown open to the public on Monday. Wholesale Manager Summey has engaged Kenneth Bartlett, a former Cincinnati boy and lately of Tampa, Fla., to take charge of the new business. Mr. Bartlett is already on the job and is patiently waiting for the disappearance of the workmen so that he can get busy. The demonstrating booths are located on the ground floor and help give an artistic appearance to this big music shop.

News comes from Steubenville of the financial difficulties of Lambert Friedl, owner of the National Talking Machine Co. On Thursday he posted a notice, announcing the closing of the business due to a "depreciation of stock." He announced that his liabilities are close to \$38,000, and that his assets will pay him out clear in time.

Manager Whelen, of the local Columbia graphophone store is still optimistic about the fall business. He said "During the month of August we simply held our own, but September opened up good, as the opening of the schools is bringing

many families home from their vacations, which naturally acts as a stimulus to business. The re-opening of the schools is usually the signal for renewed activities in all lines of business and no time will be lost from now on in getting ready to handle the fall and winter business."

The Otto Grau Piano Co. is most consistent in advertising its Victrola department. President Grau states that this has brought the company business which it would not have received by an occasional advertisement.

The Aeolian Co. is doing considerable advertising and is getting ready for a big fall trade. Manager Stotler, of the Milner Musical Co., leaves Monday for Wisconsin, where he expects to put in two weeks, seeking some gamey fish.

Manager Dittrich, of the talking machine department of the Rudolph Wurlitzer Co., says: "August was a month of exceptionally heavy record orders at a time when shipments of records were heaviest from the manufacturers. Machine orders were also very good, and this would indicate that dealers not only are enjoying an exceptionally good summer trade, but are stocking up for the fall business in spite of pessimistic reports from other channels of trade. Retail business was exceptionally good during the month of August. We are not losing any sales on account of the war conditions, and we do not expect to be effected by conditions later on in the fall. There is a plentiful stock on hand and we look for big results during the coming season."

THE MAN OF GRIT WINS.

The fellow who says "I never had a chance" is almost invariably a man who never had any grit. Grit wins. To have grit means to have determination enough to keep going, to plug away until the accomplishment of your purpose. This requires planning, studying, working with all the concentrated force that is in you. Winning means working in the superlative degree, not shirking in any degree.

GRAFONOLA RECITAL IN CHURCH.

Large Crowd of Church Members and Friends Turn Out to Enjoy Most Delightful Concert Arranged in Laurel, Md., by R. H. Sadler, Jr., a Local Grafonola Enthusiast.

(Special to The Talking Machine World.)

LAUREL, MD., September 5.—R. H. Sadler, Jr., of this town, had heard on various occasions of the use of talking machines in churches and determined to make the experiment for his own satis-



Showing Grafonola Used in Church Work.

faction. He was the possessor of a Columbia Princess Grafonola, and after arranging a comprehensive program of various kinds of music secured the use of the Laurel Presbyterian Church for the concert. The concert, or recital, was in the nature of a free social for the church people and their friends, who attended the affair in large numbers. So successful was the first recital that Mr. Sadler was compelled to follow it with others to meet the demands of the local music lovers. The accompanying illustration shows the Grafonola in position beside the pulpit.

PROGRESSIVE JOBBERS ADVERTISING IN THE TALKING MACHINE WORLD. CONSULT THEIR ANNOUNCEMENTS.

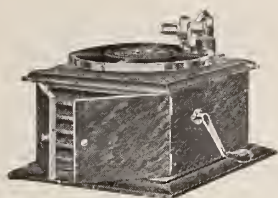

Victrola IV, \$15
Oak



Victrola VI, \$25
Oak



Victrola VIII, \$40
Oak

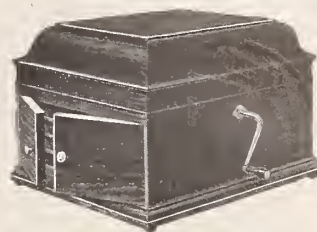

Victrola IX, \$50
Mahogany or oak

To the public, "Victrola" means the world's best music.

To the music dealer it means all that—and more. It is the very foundation of music trade success.



Victor Talking Machine Co.

Camden, N. J., U. S. A.

Berliner Gramophone Co., Montreal, Canadian Distributors.

Always use Victor Machines with Victor Records and Victor Needles—the combination. There is no other way to get the unequalled Victor tone.



Victrola X, \$75
Mahogany or oak

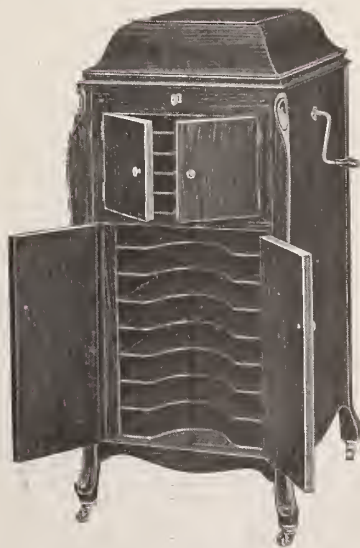

Victrola XI, \$100
Mahogany or oak



Victrola XIV, \$150
Mahogany or oak



Victrola XVI, \$200
Mahogany or oak



Good product sold to the dealer and by the dealer, strictly on its merits, co-operation always, and protection as a matter of course—that's *business*, Columbia style.



(Write for "Music Money," a book "full of meat" for those dealers interested in quick and frequent turnover of capital.)

**Columbia Graphophone Company
Woolworth Building, New York**

TRADE IMPROVES IN PITTSBURGH.

Attractive New Stores and Departments Opened—**Recital Hall in Kaufmann Bros. Store—Schoen Music Co.'s Department a Success—Reports from Other Members of the Trade.**

(Special to The Talking Machine World.)

PITTSBURGH, PA., September 10.—The consensus of the opinions of the Pittsburgh talking machine dealers indicates a marked improvement in trade during the first part of September, in fact several report a slight advance in sales over the same period of last year. The record business is on the increase and many of the houses have materially increased their lines.

New Dealers in Line.

During the past ten days two newcomers have made their appearance in the circle of local dealers. The Peloubet Co. has opened an up-to-date establishment on Forbes street, near Oakland, and is handling the Victor exclusively. The opening trade has been very encouraging and a splendid fall business is looked forward to, as the Peloubet store is located in a section of the city that is a comparatively new field for the talking machine.

A talking machine department has been installed by the Story & Clark Piano Co., 539 Wood street, who will specialize exclusively in the Edison. Several practically sound-proof booths have been constructed and are fitted up in a complete and convenient manner. The department opened for business during the week of September 7.

Pleased with Business Conditions.

The Boggs & Buhl Victrola department has been enjoying an exceptionally good business, and Manager J. A. Phelps reports a steady increase since the first of September. The location of the de-

partment on the fourth floor with the piano department is proving to be equally as convenient and attractive to customers as the old situation on the second floor.

To Open Concert Hall.

Manager H. N. Rudderow, of the Kaufmann Bros. Victrola department, expresses much satisfaction over the trade of the past few weeks, which, although not brisk, has been of a substantial character. Mr. Rudderow has just returned from a week's vacation spent at Niagara Falls and other points of interest.

The Kaufmann Bros. store opened its concert hall to the public on September 7, and in the near future Victrola concerts will be given at regular intervals.

The Schoen Music Co., 119 Federal street, North Side, reports its new Columbia talking machine department as making good strides in both the instrument and record sales. Callers have been particularly numerous recently and many fine prospects for the higher priced machines are in evidence. The new display window is being used exclusively for the display of the Columbia and is always kept freshly and attractively arranged, which is doing much to draw prospective customers.

The S. Hamilton talking machine department reports a very fair summer business in its three lines, the V. E. C. triplets. The store's show window, which is one of the largest and handsomest in the city, has been given over almost entirely during the past week to the Victor, Edison and Columbia higher-priced instruments. An Edison diamond disc, special case, instrument selling at \$400, and a new Victor No. XI, are shown to excellent advantage.

ORIGINAL PUBLICITY STUNT

Inaugurated by the Landis Music Store, Waynesboro, Pa., Brings Deserved Results.

The proper use of the original and unique in up-to-date publicity matters is the goal of every advertising man, and the unusual advertisements, car cards and publicity stunts that are turned out regularly bear eloquent testimony to this search for the distinctive.

In line with this embodiment of the original in advertising, the idea recently presented by the Landis Music Store of Waynesboro, Pa., live wire Victor dealer, is well worth attention. This company sent out to its mailing list a letter advertising the Victor, and enclosed a check for two cents "to pay for a minute of your time." The novelty of this plan was the subject of general comment, and was a material factor in the sales success of the letter.

SILAS E. PEARSALL CO. EXPANSION.

New life has been added to the Silas E. Pearsall Co., Victor jobber, 16 West Forty-sixth street, New York, by the appointment of John A. Snyder as general manager, and of Thos. F. Green as manager of sales. Mr. Snyder comes from Philadelphia, where he has had considerable experience in banking lines in connection with his talking machine experience, while Thos. F. Green, formerly the Victor man of New York, needs no introduction. Plans are rapidly being shaped by these two generals for a campaign for both wholesale and retail business that should increase the scope and prestige of this company.

The DITSON Pledge

is to see that our clientele has a better service than ever—setting a new standard in Victor jobbing deliveries. The demands of alert Victor dealers—the kind that grow—are many and varied, and we furnish the "first-aid" in every instance.

We believe this year's Victor business will be of tremendous proportions, and it will pay you to have

The Fastest Victor Service

which is a requisite in this hustling age. We possess the largest stocks, the best organization and most up-to-date equipment in the Eastern half of the country.

This covers Victor machines, records and supplies of every kind.

Will you let us tell you more about Ditson co-operation? A postal gets this information!

OLIVER DITSON CO., Boston, Mass.

PACIFIC COAST DEALERS CONFIDENT OF THE FUTURE.

Effects of European War on Fruit Shipments Being Overcome with Good Results—Phonograph Co. Occupies Handsome New Quarters—George W. Lyle Inspecting Columbia Branches—News of Travelers—Higher Priced Outfits Most in Demand Is the Report.

(Special to The Talking Machine World.)

SAN FRANCISCO, CAL., September 4.—Notwithstanding the diverting influences of the European disturbances the past month, business in the talking machine stores here held its own fairly well, and with the first excitement of war conditions wearing off now to a considerable extent, greater activity is anticipated for September. The prospects for fall and winter business in this section, except in special cases, have not changed materially in consequence of the recent developments in foreign affairs. The first effect here was a stoppage of shipping, which seriously interrupted the export movement of crops and manufactured goods, thus tending to retard current business generally, but quite a lot of ships have left for foreign ports the last few days and the difficulty of financing the export movement is not so pronounced as it was. Other operations temporarily curtailed on account of the unsettled general condition are being resumed and the trade expresses renewed confidence of gradual improvement, an indication of which is the appearance in the daily paper this week of a little more advertising space devoted to musical instruments. Dealers did but little advertising the past month on the ground that it would be money thrown away, as the public was too absorbed in other matters to read ads, the primary election tending to distract attention from business in addition to the reading, thinking and discussing of war topics.

Phonograph Co. in New Quarters.

The principal event in the local trade the past month was the removal of the Phonograph Co. of San Francisco from its old Post street location to the new Edison Shop on Geary street, facing Union Square. Final touches in decoration and minor details of furnishings were still to be made when the place was opened for business, and for that reason the formal opening will not take place for two or three weeks yet. The management of the business takes just pride in the new establishment.

One of the highest compliments that can be paid any establishment is probably that everything is in good taste, and that can truly be said of this new Edison Shop. The woodwork is red gum finish, which harmonizes with the sand-tinted walls and matches the furniture. The arrangement of the store was given much thought in order to combine attractiveness with convenience. In front is a large display and salesroom, followed by a lobby for the accommodation of visitors; then the offices, back of which are record rooms for stock and eight sound-proof demonstration rooms. The store is 140 feet deep, the display room is 22 feet wide, and the remainder is 25 feet wide. A mezzanine floor has been installed, extending from the rear to the display room. It has been fitted up for a concert hall, and its approach is one of the most elaborate features of the establishment. A stairway leads up from either side of the display room, forming an archway. In the basement are provided storage and shipping facilities. As the name signifies, Edison products are handled exclusively, and one of the chief prides of the place is a signed photograph just received from Mr. Edison, extending his best wishes for the success of the new Edison Shop of San Francisco.

George W. Lyle on Inspection Tour.

W. S. Gray, district manager of the Columbia Graphophone Co., expects to leave shortly for Spokane, Wash., where he will meet George W. Lyle. From that point he will accompany him on his tour of inspection of the company's Pacific Coast interests. Word has also been received here that Marion Dorian, of the Columbia Co., will visit the local headquarters some time in September. While here he will go over plans and specifications for the Columbia booth at the exposition next year, and look after other matters pertaining to the company's exhibit.

M. J. Sittenfeld to Travel for Columbia.

A new traveler has been added to the local force of the Columbia Graphophone Co. in the person of M. J. Sittenfeld, who was formerly manager for the company in Sacramento, Cal. He has been assigned the central part of the State as his territory and is giving good account of himself on his initial trip, according to Wholesale Manager F. R. Anglemeier. The other travelers are out also. C. P. Le Roy is in the southern part of the State, and C. J. Moore is back on duty in the San Francisco Bay district, after a two weeks' vacation at Skaggs Springs, in Sonoma County. Mr. Anglemeier says business has kept up nicely the past month in both machines and records, and he looks for improvement from now on until the holidays.

A. R. Pommer at Golfers' Meet.

A. R. Pommer, proprietor of the Pacific Phonograph Co., and Mrs. Pommer, both of whom are golf enthusiasts, are spending the early part of September at Del Monte, where golfers from all parts of California have assembled to compete for State supremacy.

New Traveler for Edison Disc Line.

The Pacific Phonograph Co. has enlisted the services of E. C. Howard. His official title is special representative and his sole mission is to solicit new business for Edison disc products. He will cover the entire Pacific Coast, and as his efforts will be confined to opening new accounts, he will work principally in localities heretofore not explored to any extent by the company.

Does Lively Business at Summer Resorts.

Special Representative Francis Raymond, of the phonograph sales department of Thomas A. Edison, Inc., in this district, spent most of the past month at the summer resorts south of this city in the interests of higher priced Edison disc phonographs. He conducted a series of recitals at the leading hotels offering special inducements to summer visitors, and no doubt Edison dealers will reap benefits from his campaign.

Get Good Stock of Victor Records.

L. S. Sherman, of Sherman, Clay & Co., Coast distributors of Victor goods, says they have been unusually busy in the record department the last week or two filling back orders following the arrival of a large shipment from the factory, containing certain records which have been anxiously awaited for some time. Here machine business is reported quite active also, and preparations are under way for a large holiday trade.

Says August Shows Substantial Gain.

H. P. Rothermel, manager of Eilers talking machine department, which was installed the first of July, says August showed a more substantial gain over July than he anticipated. Stocks have been increased in all three lines—Victor, Columbia and Edison—and all grades of machines have been selling. Edison disc products have been featured, and Mr. Rothermel says they are in particularly good demand.

Many Large Cash Sales.

P. H. Beck has enjoyed a satisfactory month's business in the Kohler & Chase talking machine department, a feature of which he says was the increased number of cash sales for machines under \$100. He considers this an indication of improved conditions, as in his experience cash sales have been largely restricted to higher priced machines.

R. E. Wolfinger, of the talking machine department of the Wiley B. Allen Co. in Los Angeles, Cal., spent a few days in San Francisco recently while on his vacation.

To the man who is always waiting for something to turn up, success is always just around the corner of the next street.

A man is known by the company he keeps, which may explain why some of use hate to be alone.

Lansing Khaki Moving Cover

is the only safe protection that you can use for wrapping machines for shipment, for it insures perfect delivery condition.

It is the same as packing each talking machine or record cabinet in four thicknesses of heavy felt, with cotton flannel on the inside to keep the varnished surfaces right, and Government khaki on the outside to insure wearing durability of the cover.

**Gives Protection Against
Dust
Finger Prints
Bruises
Scratches and
Heat or Cold**

You save all bother of re-finishing each machine, so each cover saves its cost within a week after you buy it.

Place for your name and address on the outside, so you also get advertising value.

Ask us to send you a Lansing Cover and test it yourself. Also get our Booklet No. 6 giving you full details.

Better send for these to-day.

E. H. LANSING
611 Washington St.
BOSTON, MASS.



A new Columbia at a war-time price—the "Meteor," \$17.50. It has all the earmarks of Columbia quality—quality of appearance, quality of workmanship, quality of *tone*. That is enough to ensure a market for this new instrument.



(Write for "Music Money," a book "full of meat" for those dealers interested in quick and frequent turnover of capital.)

**Columbia Graphophone Company
Woolworth Building, New York**

LOOK FOR GOOD FALL TRADE.

Indianapolis Dealers Optimistic Over Outlook—Columbia Co.'s Unique Display in Water Carnival—Kipp-Link Co. Activity—E. L. Lennox Wins Golf Honors—What the Others Report Regarding Current Conditions.

(Special to The Talking Machine World.)

INDIANAPOLIS, IND., September 9.—Talking machine dealers here are looking forward to a prosperous fall trade. The European war has not affected the local talking machine trade and the dealers can assign no reason why it should.

The Columbia Graphophone Co., 27 North Pennsylvania street, won honors recently in the water carnival held under the auspices of the Riverside Canoe Club on White river, near Riverside Park. While the Columbia's entry in the carnival did not take the grand prize—simply because it was not entered as a contestant—it received more applause than the triumphant entry. H. M. Wright designed the Columbia display. Taking two large canoes as his foundation, Mr. Wright built a living room scene which won appreciation on every hand. On the two canoes a platform ten feet square was placed. A six by nine rug was laid on the platform. A table, three comfortable rockers and a Grafonola De Luxe made up the furnishings. The pictures of Mary Garden, David Bispham, Emmy Destinn and Lina Cavalieri were placed along the front of the platform. Storage batteries supplied the electric current for the lights.

The "movie" men were on hand at the carnival and the moving pictures of the "parade" are being shown at the local theaters. The Columbia display shows up especially well in the pictures. A free exhibition of the pictures was given in Monument place the week of the Indiana State Fair, September 7-11. This week was also "Made in Indianapolis Week."

A. W. Roos, manager of the Columbia store, said business was good the latter part of August, and that the indications are that there will be a big fall business. Dance records continue to be

the best sellers, it being almost impossible to get as many as needed.

Thomas Devine, manager of the Dictaphone department of the Columbia store, is in Ottawa, Canada. Friends of Devine are worried lest the Canadian Government should pick him up and compel him to go to war for England.

W. C. Fuhri, of Chicago, district manager, visited Mr. Roos recently. Mr. Fuhri and Mr. Roos went to Terre Haute in Mr. Roos's automobile. They had a very pleasant trip and in addition attended to business there.

The Kipp-Link Phonograph Co., jobber for the Edison line of phonographs, find that it does not

Co. had a very good August trade and a large fall trade is expected.

Edwin L. Lennox, of the E. L. Lennox Piano Co., which handles the Edison line of disc phonographs, won second honors in the State golf tournament held recently at Marion, Ind. Mr. Lennox is a veteran both in the music game and in the game of golf.

PREPARING FOR NEXT CONVENTION.

Press Committee of National Association of Talking Machine Jobbers Reports Start of Work for Reunion in San Francisco.

J. C. Roush, chairman of the press committee of the National Association of Talking Machine Jobbers, in a recent communication says:

"Tentative plans are already being prepared for a banner convention at San Francisco July, 1915. Pamphlets showing special trips with privilege of returning different routes are being prepared, profusely illustrated, and will be mailed to every member of the association shortly.

"Plans for entertainment of the jobbers and their friends are being arranged, and there is no question but what the next convention will be one that every member can well be proud of. Many members have signified their intention of being present, and the attendance will no doubt be quite large, as many members will use this as an excuse to visit the beautiful Coast, Yellowstone Park and the Yosemite Valley instead of putting it off from year to year.

"Special Pullmans will be arranged for, making the trip practically a family party and members will return home with a better knowledge of their own country than they could obtain from constant reading and studying. Every member is urged to make his plans take in this beautiful trip with his family and friends."

The live-wire Victor dealer is "always on the job," as witness the aggressiveness of John J. Carroll, Victor dealer at Newark, O., who on a recent trip around the world stopped at Rome for a few days and picked up a fat order for a Victrola XVI. and a good-sized record library.



Columbia Display in Indianapolis Water Carnival.

have to do very much pushing to sell the Edison line. It's more of a pulling game to get the machines and records to supply the demand.

W. S. Barringer, of the Stewart Talking Machine Co., jobbers in Indiana for the Victor Talking Machine Co., expects to have this fall the best trade his house has experienced. Preparation has been made by the Stewart Co. to take care of heavy demands for records and machines from the dealers throughout the State.

The talking machine department of the Aeolian

from the hundreds of delighted owners of talking machines. A \$10,000 man writes that he is able to play perfectly with the Little One-Der attachment records 10 years old.

Here is a "Little Hint" for the dealer: In addition to trying out a sample on your own perfect demonstrating machine, using perfect new records, and getting demonstrations of the fine color-value, ask your customers to bring in their old records.

You will thus make a sale of an attachment and yourself get enthusiastic over our patent.

You will bring old customers into your store to investigate, and it is a simple matter then to get them to try out some of the new records. Result,

sale of a Little One-Der and of several new records.

Another way to sell attachments, if you cannot induce all your customers to come in for a demonstration, offer to send one out to the home for trial. We guarantee you will make a sale every time.

Write for 2 or 3 dozen attachments, which we will send on approval. At the end of 30 days return those you have not sold, and we will not charge you for them. Our introductory price on this trial offer is 60c. each, and you retail for \$1. Special price on quantities.

Sole Maker

**A. S. B. LITTLE
Nashville, Tennessee**



Elbert Hubbard, writing in the July issue of "The Fra," says of the Little One-Der attachment for talking machines: "It restores lost chords and takes the wreck out of records." This is only one of the many very strong endorsements we have received for our patent needle holder (shock absorber)

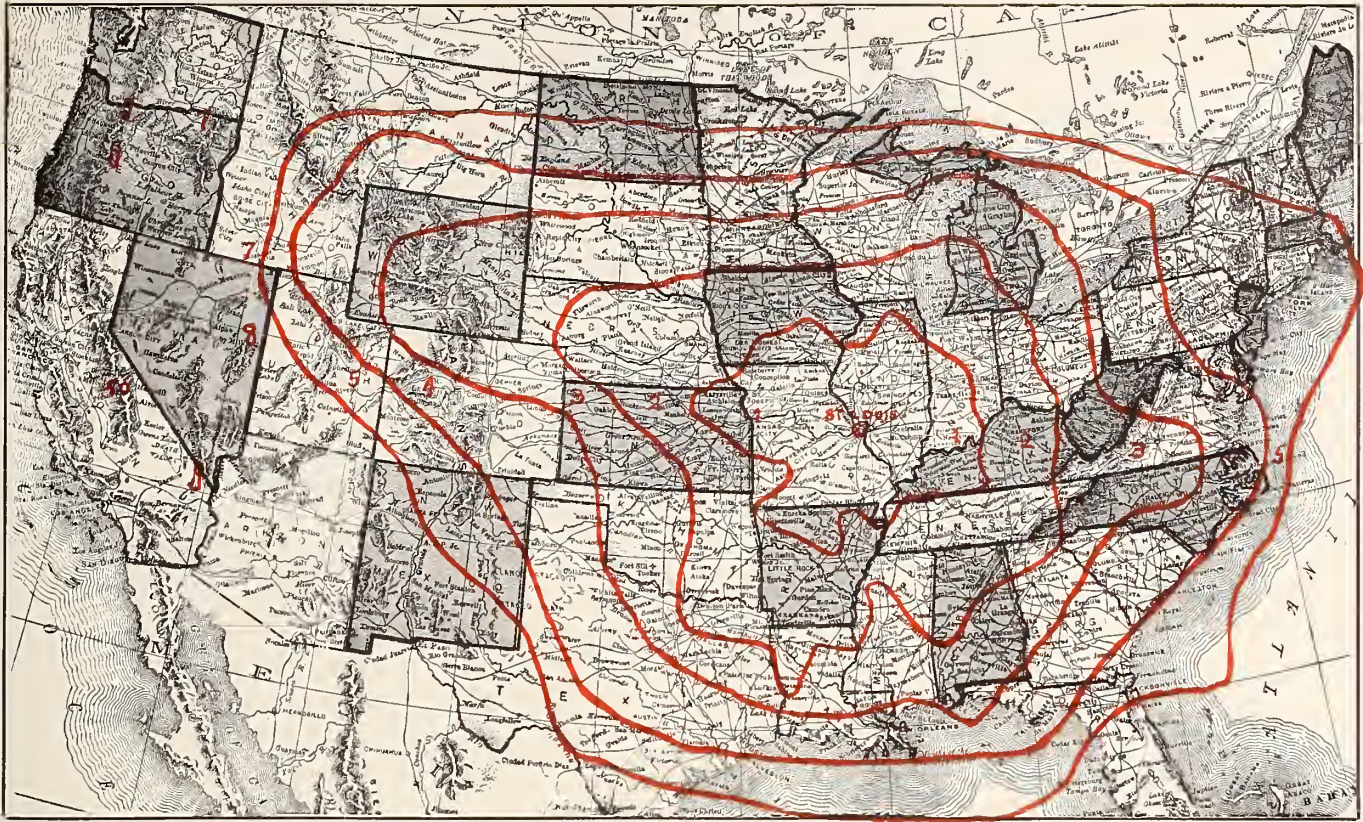

The Wonderful Freight Service of Saint Louis

LOOK at the map!
 Each circle about Saint Louis represents the limit of a day's travel of the fast freight service from here! Twelve hundred cars and more leave Saint Louis daily, carrying package freight to break bulk at car destination, and all of these cars move on SCHEDULE!

See how far freight moves from Saint Louis in One Day—in Two Days—in Three Days!

Think what a wonderful accomplishment this is—how NEAR Saint Louis is to YOU by freight!

And think how much faster our Express and Parcel Post service brings goods to you!

We are AT YOUR DOOR—and here in Saint Louis we have the BIG Victor Stock—able to fill the orders for shorts that other jobbers can't fill. If anybody in America has the Victor Records, Machines or Accessories you need—WE have!

Send us your shorts—even if you get the bulk of your Victor goods from somewhere else. Send US the hard part to fill!

Koerber-Brenner Company



Victor Distributors

Saint Louis



Harry G. Koerber
 President & Treasurer

Edwin C. Rauth
 Vice-President & Secretary

The Goods, and NOT "Regrets"

THAT'S our policy.

It compels us to carry a larger stock of Records, Machines, and Accessories than most Jobbers—but we FILL orders instead of sending our regrets, which is what you are after.

You send in orders for Victor goods because you NEED 'em. A jobber who is always "short" doesn't help you much.

So, if you're short anything now, instead of waiting for your regular jobber to get it, send us the order. If anybody in the country is stocked on the item, WE are.

We just "dote" on these "Short" items others send regrets about.

We will appreciate your short business, even if you place your regular orders elsewhere.

Koerber-Brenner Company



Victor Distributors

Saint Louis



Harry G. Koerber
President & Treasurer

Edwin C. Rauth
Vice-President & Secretary

PHILADELPHIA TRADE SHOWS PLEASING INCREASE

Over Business for Same Season of Last Year Despite General Conditions—Dealers Make Elaborate Preparations for Capturing Trade During Coming Months—Recitals and Liberal Advertising Planned—Louis Buehn Reports Steady Business Growth.

(Special to The Talking Machine World.)

PHILADELPHIA, PA., September 9.—The talking machine business in Philadelphia during the month of August was most satisfactory, and while there was not a very large increase over 1913, and especially not as large as several previous months, yet it was sufficiently so to be encouraging and to give bright prospects for the remainder of the year. Thus far nine-tenths of the talking machine dealers in Philadelphia have experienced an increased business for the first eight months of this year, every month over the corresponding months of 1913.

There is not going to be any material change in the aspect of the talking machine business in Philadelphia this year despite the harmful influence of the European war. It has reached such a staple basis that little change is necessary.

The Edison disc dealers are prepared for an active fall campaign and have thousands of circulars already addressed and ready to be mailed just as soon as they feel the proper time has arrived. They will also inaugurate an elaborate series of concerts in which they hope to reach a large number of talking machine purchasers who would understand and appreciate the Edison qualities.

The talking machine department of John Wanamaker's has enjoyed an unusually good August business. The new record racks are in place which facilitate work very materially. The sales force has been divided in such a way that at present there is an exclusive sales force to sell Victors and an exclusive sales force selling records. Concerts are being given every day in the large concert hall, in which a piano, an organ and a violin are used with a Victrola. These concerts are very largely attended. Among the Wanamaker visitors the past

week were L. C. Wiswell, the general manager of the talking machine department of the Lyon & Healy store, Chicago, and Miss Golden, a young lady who conducts a talking machine store in Indianapolis. Mr. Kingsmore, of the Wanamaker selling force, will be married the coming week.

Louis Buehn, who handles the Victor machines and the Edison Amberol, has increased his business very materially during August. Mr. Buehn spent the latter part of July and most of August at Ocean City, and last week made a tour of the Eastern shore of Maryland in his automobile. Mr. Buehn says his business has run steadily ahead of last year, every month showing a gain over the corresponding month, and he looks for an increased business in the fall and winter. Edison dictating machine business also shows an improvement over last year, and among the leading houses who have taken on this instrument are: The Keystone Type Foundry, the Ford Motor Car Co., Diston & Sons, the saw manufacturers of Tacony; Berger Brothers, and the Gurber Engineering Co. of Bethlehem.

Burkhart & Blake, at Eleventh & Walnut streets, have a most artistic and attractive window display of the Edison, and are about to erect a large display sign on their building, 13 feet wide, on the Eleventh street side. They have also built an additional booth. They report that their business on the Edison thus far has gone considerably ahead of their expectations, and they are most optimistic.

Ramsdell & Son, also Edison agents, are making arrangements to have a series of fine booths placed in their warerooms and are going to give the talking machine end of their business equal attention with the pianos. Both the Cunningham and Stetson companies are going to place experienced men in charge of their Edison departments.

The Talking Machine Co. expects to have all alterations finished by the middle of this month, and it is going to have as fine a store as is in this city on Broad street.

Walter T. Eckhart has been spending several weeks at Atlantic City. He came up to the city last Friday and returned on Saturday after he found that everything was working along in a satisfactory way. As the Philadelphia-Chicago Opera Co. will not give performances this winter on account of the war, it will give the Pennsylvania Talking Machine Co. additional room for its business. The Opera office took up quite a little space at the front of the store, but it was a good advertising medium.

Lit Bros. are continuing to enlarge their department, and it now covers close to three times the space it occupied a year ago.

Gimbel Bros. have not yet found time to make the enlargement to their department so long contemplated, but their business is growing so rapidly that they cannot delay much longer.

Strawbridge & Clothier are more than holding their own, they report, and with their new rack facilities they are finding it much easier to handle their rapidly growing business on records. Manager J. E. Priestly believes that the business is going to be very good this fall.

SUSTAIN THE PRICE.

You will notice that those business men who have really made good are in a position to make a price and sustain it, because their reputation is such that that course is justified; they are men who have been very careful to make good all business transactions by having always sincerely tried to deliver quality in proportion to price.

RETURN FROM VACATIONS.

L. A. McChesney, advertising manager of Thos. A. Edison, Inc., Orange, N. J., has returned from his vacation, which he passed in the Adirondacks.

Credit Manager Philips, who has been sojourning at Asbury Park, N. J., has also returned.

FOR SALE

My high-class retail Victor business; Established 11 years; Centrally located; Store thoroughly equipped, with well-trained sales force. Genuine opportunity for investment of \$10,000 to \$15,000 capital. Am retiring from retail business. Further details on application.

BENJ. SWITKY

9 WEST 23rd STREET

NEW YORK CITY



LOUIS XVI
 Model A450, Circassian
 Walnut, \$450.00
 Model A400, Mahogany,
 \$400.00



SHERATO
 Model A275, a
 hogany, In id
 Plain, \$275.00

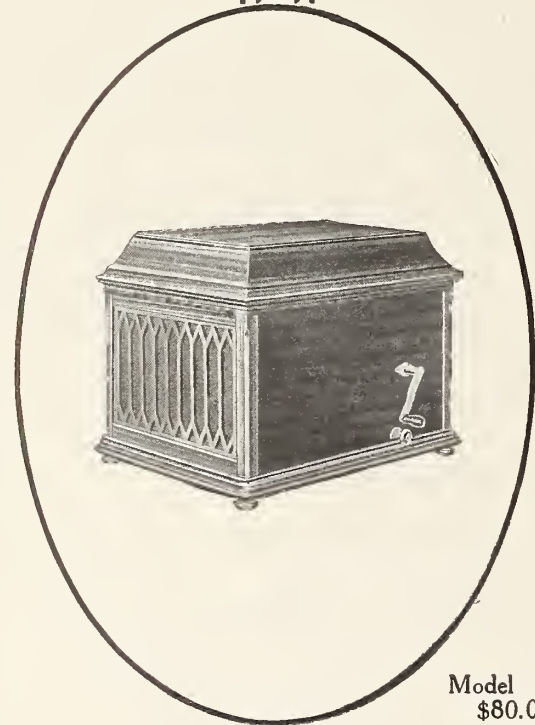

Model A80, Mahogany,
 \$80.00

As Easy As Selling High Hats to Aldermen:—

That's how easy it is to sell an Edison Phonograph to a man who knows real music when he hears it.

As soon as a few records are played, your music-lover knows that here is a true musical instrument that reproduces all the beauties of the original music. He knows that he is hearing the overtones that elude reproduction on other phonographs.

To him the advantage of having a permanent point that does away with the bother of changing needles, is instantly obvious. He

Thomas A. Edison, Inc.



Model A200, Mahogany
 and Oak, \$200.00



Model A300, Cir-
 cassian Waut,
 \$300.00



LOUIS XV
 Model A425, Circassian Walnut, \$425.00
 Model A375, Mahogany, \$375.00

ATON
 90, Ma-
 Inlaid
 uetry,

...sps the mechanical superiorities of the Edison put into it by that
 ...ster inventor who gave the phonograph its name.

The smooth running motor that gives the music its steady
 ...ch, the indestructibility of the records, the clear tone that makes
 the Edison so indispensable for any out-door affair where music is
 ...sired, the beauty of the cabinets—all these merits combine to
 ...ork on the buying instinct of the music-lover until he feels that he
 ...mply cannot get on without an Edison.

The Edison does this for itself—it is its own best salesman. Your
 ...rt comes in seeing to it that you have the full Edison Line. You
 ...st not let that buying-instinct find its outlet in another store
 ...cause you have not the type of Edison your customer desires.

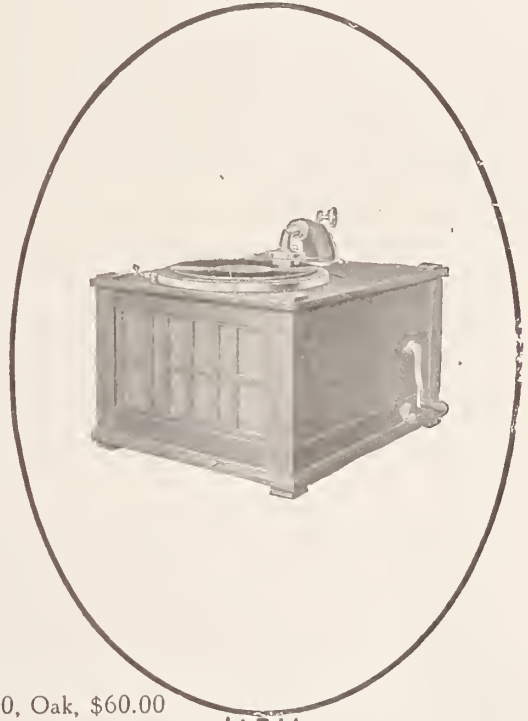

Model B60, Oak, \$60.00

akeside Ave., Orange, N. J.



Model A150, Mahogany and Oak, \$150.00

50, Ma-
 and Oak,

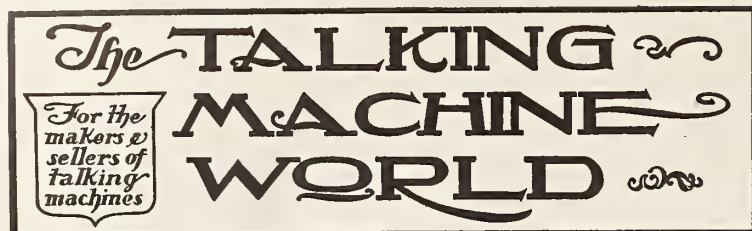

EDWARD LYMAN BILL, - - - Editor and Proprietor.

J. B. SPILLANE, Managing Editor.

Trade Representatives: GLAD. HENDERSON, C. CHACE, L. E. BOWERS, B. BRITAIN WILSON, A. J. NICKLIN, AUGUST J. TIMPE, L. M. ROBINSON.

Boston: JOHN H. WILSON, 324 Washington Street.

Chicago Office: E. P. VAN HARLINGEN, Consumers' Building, 220 South State Street.
HENRY S. KINGWILL, Associate. Telephone, Wabash 5774.

London, Eng., Office: 2 Gresham Buildings, Basinghall St. W. LIONEL STURDY, Manager.
Representatives for Germany and Austria: VERLAG NEC SINIT, Berlin C. 19, Ross-Strasse 6, Germany. GEO. ROTHGIESER, Director.

The Talking Machine World has regular correspondents located in all of the principal cities throughout America.

Published the 15th of every month at 373 Fourth Ave., New York.

SUBSCRIPTION (including postage), United States, Mexico, \$1.00 per Year; Canada, \$1.25; all other countries, \$1.75.

ADVERTISEMENTS: \$3.00 per inch, single column, per insertion. On quarterly or yearly contracts a special discount is allowed. Advertising pages, \$100.00.

REMITTANCES: should be made payable to Edward Lyman Bill by check or Post Office Money Order.

NOTICE TO ADVERTISERS.—Advertising copy should reach this office by the first of each month. By following this rule clients will greatly facilitate work at the publication headquarters.

Long Distance Telephones—Numbers 5982-5983 Madison Sq.
Cable Address: "Elbill," New York.

NEW YORK, SEPTEMBER 15, 1914.

WAR talk has been dominant throughout this land during the past month, and even a trade publication has to devote a certain amount of its space to the discussion of war and its effect upon trade.

So closely is the world bound together by ties of business and friendly intercourse that what affects one nation is bound to affect the others. We cannot have half the world engaged in the most destructive conflict of all the ages without having an immediate effect upon the interests of other countries.

There is inconvenience and loss and suffering for the peoples of all continents because the European nations have drawn the sword.

The organized interests of man everywhere are so interdependent that commerce, finance and industry suffers loss, and must suffer more and more as the conflict deepens.

We talk about a neighborhood of nations, and yet it is a neighborhood without brotherhood; and by the awful scourge of hatred all nations are learning that neighborhood without brotherhood is hatred and death.

The sciences and arts of peace are made to belie themselves in the ruthless service of carnage and slaughter.

Something must be wrong with our civilization when, in 1914, millions of men confront each other on the battle field trying to decide the quickest way of wiping each other out.

All our talk of close brotherhood—all our talk of arbitration, of treaties backed by the preparation for war.

Armed peace is forever disproved and doomed as an instrument of international safety. There can be no such thing as armed peace. It contradicts itself, for peace that must arm is no peace. In spirit, in motive and all of the moral qualities of conduct it is war. All it lacks is opportunity. Give it occasion and the brute-force war features are made manifest.

If "war is hell," then it is plain that armed peace is hell's wide-open gate.

THE industrial conditions throughout Europe are sadly disrupted. Business organizations are broken, and the question is how soon will they be reorganized. Some never, because the brilliant minds which once directed them are no more, and the losses of the warring countries of Europe, in fine citizenship, cannot be reckoned in money standards—it is beyond pricing.

But the responsibilities of America in this great conflict are great, for in this crisis it is to the United States, with her vast resources, her fields of grain, her great stores of riches and gold,

manufactures and human energy, that all the world is forced to turn for leadership.

The countries at war must have American wheat and American meat. They will want, and try to obtain, munitions of war from American factories. With their own shops closed, the workmen at the front, rifle in hand, will need American cloth, iron, steel, shoes, saddlery and products of every kind, and bound as we are by ties of blood and business to every nation of Europe, when the day comes when the great armies of Europe shall have made their last final payment in human life to the god of war, and peace once more smiles upon the people in the war-torn lands, then it will be through the good offices of America—the melting pot of all nations—that the way will be paved for conferences and new treaties.

The prostration of the manufacturing interests of Europe will make it impossible, by reason of the results of the war, for any great revival in export trade from those countries for some time to come. And America, by reason of these unfortunate conditions, has an unlooked and unsought for opportunity opening up. The war will throw us upon our own resources, and compel us to develop raw and unfinished materials for the supply of which we have been relying upon European countries.

OUR vast resources in every line will be developed, and the United States will make itself almost immediately independent of the rest of the world in its manufactures.

Opportunity, through Europe's misfortune, is knocking at America's door louder than she ever knocked before at the door of any great nation.

From present appearances it would seem as if within the immediate future there would be an unprecedented boom in almost every line of trade.

Prominent industrial leaders have been interviewed, and they declare that they are preparing for a new era of business, and that this activity will include a varied line, so that American industries will leap ahead and employ all available labor, and within a brief time it is possible that every smokestack in the country will be pouring out its thickest clouds and every loom will be turning, and every artisan and day laborer will be at work.

America, being the only great nation not embroiled in war, must supply to the other nations of the earth enough of its products and manufactures to cause the greatest of activity among us.

AMERICAN inventive ability will come to the front as it has never come before. Thousands of Europeans will invent no more, and the loss to those involved countries will be vastly more than the loss of either property or wealth; and notwithstanding that thousands of the brightest and brainiest men must go down before the rain of hail and death, civilization will not halt, and the virile minds of Americans—the people of this new land—will quickly repair the loss.

Meanwhile we must feed the war-torn lands—we must carry the commerce of the destroyed and imprisoned ships, and to do that we must work—all of us.

There is no time to sit back and fill the air with gloomy predictions.

It should be plain to everyone that this country will boom as it has never boomed before, that the money equilibrium will be steadily adjusted, and that men in every line of trade will feel the necessity of work as never before.

IN New York we are too close to the cable connections, too close to Wall Street, too close to the great shipping interests, too close to the great dailies which issue extras every half hour, not to be more keenly susceptible to the war conditions than any other part of the country. Therefore, it is assumed that New York's general trade would be quiet; and yet we can point to instances in the music trade where some piano houses have scored the best August trade that they have had for many years.

They have done it through organization—through work, and that is exactly where the talking machine men can take advantage of the present conditions and reap good results.

In the great agricultural sections of this country the people

are not influenced by the war conditions. They are getting more for their crops than ever before, and the prices will still go higher. They will have more money to spend for home accessories, such as pianos and talking machines. They will buy more automobiles, and their good fortune will be reflected in the demand upon factories in all lines of trade.

And so it goes!

The absorptive power of the hundreds of millions of people, plus the additional call which must come from Europe, is pretty sure to make this country a hive of industry and activity for months and years to come.

It is not the time for pessimistic talk.

The man with a grouch has no place.

We have so many things in our favor that we should think of them and discuss them rather than the sad misfortunes which have befallen others.

We are free from war. We have good crops—the greatest ever.

We have a hundred million of people who make the best market in the world.

We have good resources at our command, and all we need is just a little plain, ordinary, every-day common sense and to keep steadily at our task.

Just pull strong and steady.

THE talking machine business, while undergoing changes, is broadening out all the while. In fact, its development has been phenomenal, for when we compare the conditions which existed in this industry half a dozen years ago with those of to-day we must not only admit its wonderful development, and the advanced position which the talking machine occupies to-day in public esteem, but also the constant business changes which the industry has undergone.

All new industries have sooner or later to succumb to certain fixed business conditions, and the talking machine trade, like many others, is gradually reaching up to a position of mercantile greatness.

The relations of the jobbers and dealers are clearly defined, and it seems but reasonable to believe that the jobber cannot have two points to his business needle, so to speak. In other words, that it is not well for him to job different lines of talking machines. Concentration pays him best and pays the manufacturer best, because where he has concentrated upon particular lines he can offer no substitutes to inquiries which may come to him from dealers developed by the manufacturer's national advertising. He cannot say, "I can supply you with so-and-so," but simply one product, and that product he talks, believes in, knows its value, and all his salesmen become imbued with the spirit of loyalty towards the particular product. That loyalty always makes for business advance.

That clearly defined conditions seem to have worked out in a satisfactory manner, and in our estimation there will be no radical changes in the relations of jobbers to manufacturers within the near future.

With the retail trade it is different, and there is an unmistakable trend in the talking machine world to sell such products as are demanded by the public. In other words, to follow the lines adopted by the great department stores to sell that which the people call for in the line of manufactured products. That would seem to be good, sound retailing, and it is following out the public service plan in an efficient manner, which mercantile emporiums must do in order to satisfy the public needs.

That is a fixed mercantile principle in all lines of trade.

It does not matter whether one has a special talking machine store, music store, shoe store or a general department store.

The same principle applies to all, and a number see no good reason why they should lose sales when a customer comes in and demands a special talking machine any more than a special brand of shoes or hats.

The party who enters a store and asks for a particular product had that product in mind when he entered the establishment, and, of course, the salesman may try to force a substitute upon him, but in the meanwhile he weakens his position as well as his energies by attempting to convince a customer against his will. It is getting to be more and more a question of merit backed by values. A product which is generally advertised, and which possesses unusual merits, has the decided call in the public mind, and the dealers will do well to sell that product; but if another product is sought, it would simply be good merchandising to follow along the lines of least resistance and supply those products which the public asks for and desires.

In the talking machine line, while there is no restricted territory, it varies very materially from the piano business where there is restricted territory, and the piano men are exclusive representatives within certain prescribed lines.

The talking machine retailer sells to all who may visit his emporium, and it therefore seems good logic to conduct a store along lines of satisfaction to the public in supplying the particular products which are called for. The dealer will unquestionably seek to follow lines which afford them increased revenues by making all sales possible. Therefore, the position of the jobber and the retailer, to our mind, is entirely distinct and separate.

WE have before us an advertisement put forth by one of the large dry goods companies in a Western city in which a \$100 talking machine is offered for twelve and a half cents a day, the daily payment being brought out in very heavy type to attract readers by reason of the low cost.

Such advertising does not tend to increase the value or prestige of the talking machine in the public estimation. In fact, in our opinion, it lowers its standing very materially.

To advertise an artistic product for twelve and a half cents a day is belittling it, and is lowering it to a point which is seemingly unnecessary and not warranted by present conditions.

The payments would amount to less than four dollars a month, and that means more than two years before the machine is paid for. The same offer also includes six double records. Now, is it good business to put forth this kind of publicity in behalf of the talking machine? We do not think so. Nor do we think that it harmonizes with the marvelous advertising put out by the great producing houses.

— DOME RECORD CASE —

Is constructed along different lines, being reinforced at the bottom with a nickel-plated metal support to keep the records in position. Holds 20 records accessible for instant use. Index shows just where each record is. Furnished with lock and key. Notice how the case

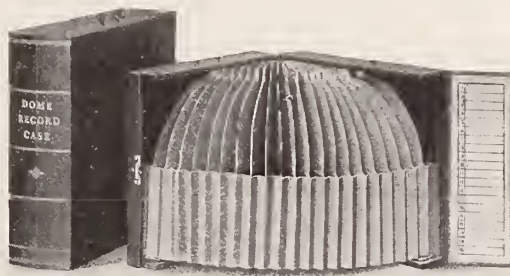

Swings Open, Displaying All the Records.

Furnished in 10" and 12", with a positive guarantee of satisfaction.

Ask us for more particulars to-day.

— W. D. ANDREWS, Buffalo, N. Y. —

We are also Victor Jobbers, carrying every model of Victrola in stock and an immense number of records. Our shipping service guarantees the quick delivery of goods—thirteen lines of railroads, five express companies, and also the Great Lakes boat lines. Include some records with your Record Case orders!

THE TRADE IN BOSTON AND NEW ENGLAND

JOHN H. WILSON, MANAGER, 324 WASHINGTON STREET, BOSTON, MASS.

(Special to The Talking Machine World.)

BOSTON, MASS., September 9.—Gradually the Columbia Graphophone Co.'s establishment is getting into a completed condition after several months of more or less upheaval due to the cutting through of Avery street to Tremont, next door. While this thoroughfare is not yet finished, the entire side of the Columbia Building is completed, and long signs extending down the length call conspicuous attention to the Columbia house. These signs can be seen practically through a long length of three streets. Both floors and the basement of the building have undergone a change, and all that the growing business under Arthur Erisman's management may be the further advanced. The basement is used for storage purposes and new racks and electric installations all add to efficiency. The long line of demonstration booths on the ground floor are done in French gray, which is the finish of the whole floor, and they are so constructed that the entire line can be thrown into one if required through the opening of windows between one booth and the next. There are two doors on the opposite sides of each booth, and ventilation is afforded through the opening of a window in the top, for the booths do not run up to the ceiling, there being a large open space at the top. New demonstration booths have been installed on the second floor and the long windows on the new Avery street side will give splendid opportunity to display goods. One advantage of the new arrangement will be that there is a room solely devoted to the housing and demonstration of foreign records, these in twenty-eight different languages being kept constantly. Manager Erisman reports that despite general business conditions and the changes going on inside which somewhat inconvenienced the office routine, the August business in Columbia outfits was exceedingly gratifying.

Arrange for Victor Demonstration Room.

The changes that have been going on for the past several weeks on the third floor of the Eastern Talking Machine Co., have been completed. This floor will be used exclusively for a Victor demonstration room, and as customers will have the benefit of adequate elevator service from near the entrance, the Eastern's many customers can now procure their goods under improved conditions. All the rugs throughout the store have been cleaned and refreshed, and the whole establishment has undergone quite an improvement from top to bottom.

Preparing for the Fall Campaign.

At this writing the staff of salesmen under Manager Silliman, of the Boston offices of the Pardee-Ellenberger Co., are at home and mapping out their routes for an early fall trip. Already there are large orders for the Edison disc outfits coming in to the Pardee-Ellenberger Co. from all over New England, and the prospect looks exceedingly bright for a good fall trade, according to Manager Silliman. Mr. Pardee was over here a few days ago, and was well pleased at the amount of business being done from the Boston headquarters. Mr. Silliman was able to take a fortnight off the latter part of the month, and with Mrs. Silliman went down to Narragansett Bay, R. I., for a vacation.

New Columbia Dealers.

Manager Erisman, of the Columbia, reports a large list of new Columbia dealers for the past month, and among those with whom he has signed up are J. G. Heichner & Sons of Holyoke, the Bon Marche Co. of Lowell, Charles Wing of New Bedford, and the Atherton Furniture Co. of Worcester. All of these have been sending in orders of so large a nature that they can be filled only in instalments. Another new Columbia dealer nearer home is C. Skelton & Sons, 312 Washington street, Newton, who conduct a chain of three stores in the Newtons. This concern has stocked up well in anticipation of good fall business.

Chickering's Department Enlarged.

As mentioned last month the talking machine department of Chickering & Sons was being considerably enlarged and improved. This work is now finished and a good part of the second floor of the artistic retail house of this large piano concern on Tremont street is now occupied for this branch of the business. The house originally started with the Victor outfits, but lately it has taken on the Edison disc line and with the necessarily added demand for goods more space was requisite. There are five sound-proof demonstration booths and a good-sized salesroom. The suite is finished in white and all the appointments are most attractive. When the work was completed, W. W. Longfellow, the manager, was able to take a short vacation, which he enjoyed down on Cape Cod. He is now back and ready for the fall business, which he expects will be gratifyingly good.

Returns to Business Harness.

Henry A. Winkelman, manager of the Victor department of the Oliver Ditson Co., is back home from his vacation, which was spent at Swan's

Island, Me., a place to which he and his family have gone for a number of summers. Business at this establishment is reported to have made an excellent showing during August, and the prospects are bright for a good fall trade.

Music for the Prisoners.

Florentio Constantino, the noted tenor, has made a gift of a Columbia Grafonola to Sheriff John Quinn, of the Charles street jail, and the sheriff will use it to entertain his prisoners. One of his bondsmen having surrendered him a short time ago in the suit against him by Oscar Hammerstein, Constantino was obliged to languish in jail for a time, and it was while there that he realized how much music might play in the lives of the prisoners. So he decided to furnish music for them through the means of a Columbia outfit.

New Quarters for Walter Bates.

Walter Bates, who has been located farther down Summer street for some time, has now moved up into the retail section of the city, and within the past few days he has got firmly settled in his new quarters at 63 Summer street. Mr. Bates has large floor space on the second floor, and with many conspicuous signs displayed on the outside there is little danger that one will not be able to find the place. The interior is comfortably fitted and there is a large stock of the Edison disc machines, Columbia and Victor outfits on hand, so that a prospective purchaser has a wide variety to select from. The location of Mr. Bates's warerooms should prove of advantage in building up a good trade.

E. F. Taft's Vacation.

Manager E. F. Taft, of the Eastern Talking Machine Co., is planning to go away on a brief vacation shortly. His trip will necessarily be short as his immediate attention is being devoted closely to business.

Arborway Pharmacy to Sell Talkers.

The Arborway Pharmacy, which is conducted by L. J. Murray, is one of the latest places to handle Columbia outfits in the outlying sections of the city. Mr. Murray has a fine selection of the leading types, and as an inducement to business he has opened a voting contest, and a handsome Columbia Grafonola is one of the prizes that is offered.

Winston Churchill and the Dictaphone.

At the office of the Columbia Graphophone Co., it is learned through Manager Erisman that one of the latest distinguished personages to appreciate the value of the Dictaphone is Winston Churchill, the well-known novelist. Some time ago Mr.

EDISON DIAMOND DISC PHONOGRAPHS

Are conceded to be the greatest sound reproducing machines ever made and the country is going wild about them. You ought to have this line in your store and if you will write to

THE PARDEE-ELLENBERGER CO., Inc.

Boston, Mass.

New Haven, Conn.

you will secure the complete information regarding the qualities of this line and our plan for laying out your department for the general promotion of business that will eventually mean a whole lot of profits for you.

Send for this data today.

Real Music
At Last

Real Music
At Last

THE TRADE IN BOSTON AND NEW ENGLAND

JOHN H. WILSON, MANAGER, 324 WASHINGTON STREET, BOSTON, MASS.

Churchill had his attention directed to the value of this device, and it did not take him long to become convinced that a Dictaphone would immeasurably serve him in his writing. So he came in touch with the Columbia people and a fine machine lately was expressed to his summer home at Winsor, Vt. Now Mr. Churchill sits back and lets the Dictaphone do his work for him as he carries on conversations between his characters of fiction.

Has Scored a Great Success.

"Billy" Fitzgerald, as all his friends know him, has been one of the faithful employes of the East-



W. J. Fitzgerald.

ern Talking Machine Co. for the past fifteen years. He began with the company as an office boy and has passed through successive stages of the talking machine business until to-day he is the manager of the wholesale department. A couple of years ago when the field for the Victor goods in public and private schools was first developed, Mr. Fitzgerald was one of those early on the scene, and he has been the medium of having Victor outfits installed in a great many schools in Boston and neighboring cities and towns. He has a wide circle of friends, and he has sold outfits to a number of prominent persons, many of them in official public life.

Exhibition of Cups Won for Dancing.

In the windows of the Eastern Talking Machine Co. there is on exhibition some of the cups which have been won by Mr. and Mrs. Otto F. C. Heineman, prominent instructors of the modern dances in this city. The cups were won by them at a recent carnival of dancing over in New York. In teaching dancing, the Heinemans use five Victrolas.

Showing New Machine.

Manager Erisman is showing to the trade a new Columbia machine, the Meteor, as it is called, which sells for \$17.50. It comes in between the low-priced machine and a higher one, and it is believed that there is a demand for it. Many dealers already have placed large orders for the Meteor.

Steinert Quarters Done Over.

The Arch street Victor quarters of M. Steinert & Sons are now entirely done over. Mention already has been made of certain improvements which Manager Royer contemplated. With the additional demonstration booths on the ground floor, certain other changes and a rearrangement of the second floor where Mr. Royer's private office is, these Victor warerooms are among the finest here.

Manager Royer has just returned from a second trip into Canada with two of his Arch street office staff, and on the auto trip this time, taken as before in his speedy Paige-Detroit car he was accompanied by Charles M. Urllass, one of his ambitious, hustling young men, and Charles Morrill, who was one of his guests on the other trip. And friend Royer knows the art of hospitality.

CO-OPERATING WITH TEACHERS.

Dealers Who Take Advantage of the Possibilities in the School Win Proper Reward.

The progress that the school product of the Columbia Graphophone Co. is achieving throughout the country is well exemplified in the accompanying illustrations taken at the Walton Street Playground of the Fitchburg, Mass., school district. The machine being used is a Columbia "Favorite" on a "Mobile," and the evident pleasure of the children speaks volumes for the popularity of the Grafonola in school work.

The machine being used by this class of pupils was sold to the school by Kidder & Davis, of Fitchburg, Mass., Columbia representatives, who are taking full advantage of the opportunities presented in the school field, and are giving every possible co-operation to the school authorities in the use of the machine and records. For the fall of 1914 Kidder & Davis have laid far-reaching plans in the direction of school sales, which will undoubtedly tend to further increase the popularity of Columbia school product in Fitchburg. In the picture herewith the pupils are performing a folk-dance to the music of the Grafonola under the guidance of Miss Isabel Dennett, a teacher in the Fitchburg schools, who is an enthusiastic admirer of Grafonola music in school work.



Columbia Favorite on Mobile for School Use.



Dancing to Music of the Grafonola in a Fitchburg School.

The largest manufacturer of
Talking Machine Needles
is located in the United States

To be exact, the plant is at Lowell, Mass., one of the biggest manufacturing cities of the country. It was in 1870 that the needle business of W. H. Bagshaw was established, and the first talking machine needles were made by him. The business has steadily grown, until our shipping record reached the tremendous number of over 63,000,000 needles in 10 days, and even then our capacity was not taxed to its extreme. Every needle a Bagshaw-made quality needle—which means the best in the world at any price.

W. H. Bagshaw, Lowell, Mass.

Pioneer Maker and Largest Manufacturer of Talking Machine Needles



Columbia instruments: A line to fit the pocket-book of every possible buyer of a talking-machine. Columbia records: A line from which every dealer can meet the musical preferences of anyone who owns a talking instrument.



(Write for "Music Money," a book "full of meat" for those dealers interested in quick and frequent turnover of capital.)

**Columbia Graphophone Company
Woolworth Building, New York**

MORE ECHOES OF THE RECENT JOBBERS' CONVENTION.

Further Impressions of the Meeting at Atlantic City Set Forth by Benj. Switky, the Prominent Victor Distributer—The Jobbers' House in Order and Some Views of Efficiency—Real and Imaginary Competition and Its Effect on the Business of the Dealer.

Part 2.

In last month's contribution I mentioned as one of the benefits of convention attendance the social and intellectual intercourse with other men in the same line of business.

As we strolled along Atlantic City's wonderful boardwalk we discussed the sacrifice of time required to attend the convention, also the possible loss sustained by one's business during the absence of the executive.

In this connection one of my fellow-jobbers delivered himself of the following forceful epigrammatic opinion:

"Any jobber whose business is in such shape that he cannot be spared for a few days would do well to call in the service of an efficiency expert!"

The truest words ever uttered! They cannot but interest the jobber and dealer alike; in fact, they are applicable to any business. Wherever the force numbers more than one employe it is the duty of the executive to surround himself with help so trained that at least one of them will fill the role of lieutenant well enough to substitute for the boss at least for a few days. But before one can enjoy the luxury of an acceptable substitute it is necessary to have the work of the business so systematized that others besides yourself will know how to handle it. This in itself is a great advantage. It means the elimination of haphazard guesswork. It means subdividing the work into several logical departments and training each employe to do the work of one or more of those departments effectively and conscientiously. It also means relieving yourself of the burden of a thousand and one details, and the placing of responsibility onto several shoulders so that routine work and even occasional extraordinary work and decisions will be handled through these channels without constant supervision by the proprietor.

One of the most successful means of raising the efficiency of an employe is by making him responsible for a certain branch or department of the work. Then follow that up by impressing on his mind that his salary will increase exactly in proportion as the need of supervision decreases.

Supervision costs money. The foreman of a gang of ten men receives his pay from the wages of those ten men. It means that eleven men must be paid for the work of ten.

And when the executive confesses that he cannot leave his business for a few days it means that he has failed to train his employes properly. It means that he is devoting his time to petty details, whereas he should be free to do the big things. It means that he is not getting out of himself all the efficiency and work which his business should receive.

There come times in the life of every man when, either through sickness or some other unfortunate cause, he is compelled to relinquish the

helm temporarily. Woe unto the business that cannot produce another hand trained sufficiently to take the helm and guide the ship!

It is a sad commentary on the ability and sagacity of the business man who had neglected the precaution of providing an understudy to assume his role in case of emergency.

It is likewise no compliment to his progressiveness if he keeps his business in such a state of chaos that it is momentarily threatened with loss or destruction because of his absence.

It is an injustice to his family and to all dependent on him. It is as bad as leaving no will after death. The man who has a profitable business should seek to perpetuate it for the benefit of his heirs. This can only be done by systematizing the business and properly training your help as to efficiency and loyalty.

Competition—Real and Imaginary.

"If the dealer would only stop worrying about the bad business which his neighbor is trying to take away from him!" This was the naive way in which one jobber expressed himself on the subject of instalment competition.

His remark was but one of the many clever utterances which it was my privilege to hear at the business session of the convention. His words struck me as being so forceful, so full of material for thought and reflection, that I cherished it and promised myself that in the near future I would make it the text of a sermonette.

"Stop worrying about the bad business which your neighbor is trying to take away from you!"

Some men will say, "Competition is competition. It is real. It means that you must meet it, fight it, overcome it, or yourself be vanquished."

I grant that competition is competition and cannot be ignored. But is it not a fact that many forms of competition against your neighbor prove more harmful to yourself than to him? Is it not a fact that the dealer who tries to put one over on the other fellow by means of still easier instalment terms proves to be his own worst enemy?

Every dealer should decide for himself the terms which he considers he can properly offer as a bid for business. He should take into consideration his own financial capacity as well as the length of time which he thinks can safely be extended to a prospective instalment purchaser. Having his schedule of minimum terms, he should steadfastly turn his face away from the lower terms which his neighbor may offer.

For example, because your neighbor offers \$200 Victrolas on thirty days' free trial is no reason why you should do the same. On the contrary, if you will watch and wait a while you will notice that he sooner or later withdraws his offer. There you have the answer why you should not imitate him. If it were a good scheme he would not discontinue it.

You may never know why he dropped the

scheme as if it were live coals; but he knows. You might guess if you think hard enough.

Because your neighbor offers the public \$15 Victrolas on such terms as nothing down and fifty cents a week is no reason why you should do the same. Those who have played at the game will tell you, if they wish to be truthful, that such inducements attract a host of incompetent and irresponsible buyers. The fifty-cent accounts—most of them—are the rottenest in the ledger. It costs too much to keep after them and the percentage of losses is considerable. If the customer cannot pay one dollar a week you should have nothing to do with him.

Sometimes competition is *not real*. There are times when the customer is bluffing you. No doubt you can recall an instance when you quoted a prospective customer \$10 down and \$10 a month on a certain type of machine, and he would say in surprise, "Why, So-and-so offered me the same machine for \$5 down and \$5 a month!" After you had told him that you could not lower your terms, have you not had him say to you, "Well, now, if you'll let me have it on the same terms as So-and-so offered it, I'll buy it from you"?

Did it never occur to you that the customer was not telling the truth? That he was playing one dealer against the other? If he considers So-and-so's terms satisfactory, why does he offer to give you the preference?

Competition is a fight, but we do not always use the right weapon for the battle. Many a victory can be won by good arguments, by salesmanship, by offers of superior quality in service. To lower your terms so as to beat the already unreasonable offer of your competitor means fighting with a double-edged sword. The harder you press the more you suffer.

It is better to do a modest, conservative, profitable business than to follow your competitor who blindly and vaingloriously scatters his goods to the four winds of heaven, reaping the whirlwind as his harvest, piling up assets that will never be convertible, dissipating his own capital, and dragging his creditors into the maelstrom.

Get together! Become intimately acquainted with your neighbors. Be friendly. Talk over these conditions. Agree on a sensible course of action, and pay no attention to the fellow who refuses to come into the fold.

"If the dealer would only stop worrying about the bad business which his neighbor is trying to take away from him!"

ALWAYS ON LOOKOUT FOR IDEAS.

A New Englander was talking to a fellow dealer from another part of the country, and said that he had visited many towns and cities. "I always make it a point in practically every city I visit to see the talking machine stores. I never yet have failed to pick up some new ideas pertaining to store arrangement, window displays, methods of handling business, or some other item of information that makes the visit well worth while. In return I endeavor to impart as much information as possible, when requested, to the dealer whose store I am visiting."

For
VICTOR DEALERS

Salter's Trade Maker, No. 19

This Cabinet will put "pep" and "ginger" into your sales instantly. It gives the appearance, effect and service of an expensive Victor-Victrola, and cuts the price in half.

You don't have to be a Sherlock Holmes to figure out its sales possibilities. Cabinet No. 19 and Victrola No. 9, as illustrated, make a wonderful combination.

Show Them Together and A Sale Invariably Follows

The cabinet is built to match, and it harmonizes in every detail with the machine itself. A counter-sunk top holds the machine firmly in place. The felt-lined compartments insure the owner of valuable records against their damage by scratching, warping, etc.

This and other practical, low-priced Salter Cabinets will draw a lot of *new trade* to your store. Write to-day for catalogues, folders, prices and full information, and rush your fall and holiday orders.

SALTER MFG. CO.
339 N. OAKLEY BLVD.
CHICAGO

A Great Combination!



SALTER CABINET
No. 19
With Victrola IX

BELIEVE IN PROGRESSIVE POLICY.

J. W. Knox & Son, of Springfield, Mo., Have Built Up a Splendid and Growing Talking Machine Business in Their Territory.

(Special to The Talking Machine World.)

SPRINGFIELD, Mo., September 8.—An concern that has won flattering success in the talking machine field is J. W. Knox & Son of this city, who, starting only four years ago with a small stock of Victor goods have advanced to a point where they are at present recognized as among the most progressive talking machine dealers in the State.

J. W. Knox, founder and head of the company, has been in the sewing machine business since 1878. The present firm was started in 1903 and handled sewing machines exclusively until 1910, when the Victor line was added. A year later the

Columbia line was also taken on and the business grew to such proportions that the sewing machine end is now looked upon as a side line.

Knox & Son carry a complete line of both machines and records and are strong believers in original and persistent advertising, both through the medium of the newspapers and by cards and circulars. The accompanying illustration of the showrooms of the concern convey some idea of extent of the business handled.

WORKING ON THE "MILLIPHONE."

New York Inventor Plans Form of Telephone Exchange for Talking Machine Enthusiasts—Details Kept Secret for Time Being.

In a store in the Harlem district of New York City a shrewd inventor is quietly testing out his latest invention, which he calls the "Milliphone". It is really an automatic phonograph exchange, where you can drop a nickel in a slot and hear any piece of music, vocal or instrumental, you may desire..

The inventor is J. D. Millman. He got his idea from the switchboard of a telephone exchange, but he had to devise mechanism which in no way resembles that.

In the store where the "Milliphone" is being "tried upon the dog," are twenty-eight machines resembling phonographs. You sit down before any one of these. Before you is a book containing a list of about 3,000 selections, classified and numbered.

Above is a dial with four faces, each bearing numbers from 0 to 9. You select from the book the piece of music you desire to hear and set the numbers on the dials to correspond with its number, there being one dial for thousands, one for hundreds, one for tens and one for units. You drop a nickel in the slot and the machine begins to grind out the music.

Just how it works Mr. Millman will not tell; the mechanism is concealed, but he admits that, just as a telephone central has women operators to make the proper connections, so there are operators to connect the discs with the machines.

The inventor believes that this system of his will solve the problem of connecting a central phonograph exchange with every home in the city by means of electric wires, so that no one need buy phonograph records, but merely call up central and tell "her" to put on any music he may desire.

DANSANTS AS TRADE PROMOTERS.

(Special to The Talking Machine World.)

DES MOINES, IA., September 7.—Realizing the popularity of the modern dances and the part that the Victrola can play in the proper teaching of these dances, Chase & West, Victor distributors in this city, recently arranged for the holding of informal Victrola dansants on their wareroom floor, the success of which may be gleaned from the following notice which appeared in the leading newspaper of this city:

"Miss Ethel Veatch and Conrad Nagel gave four exhibition dances of the popular steps of the tango and hesitation on the main floor of the Chase & West store last evening. The music was furnished by a Victor-Victrola. The entire main floor and balcony were crowded with persons interested in the dances which have become so popular during the last two years."

Look good, be good and do good and perhaps you may make good.



Attractive Store of J. W. Knox & Son, Springfield, Mo.

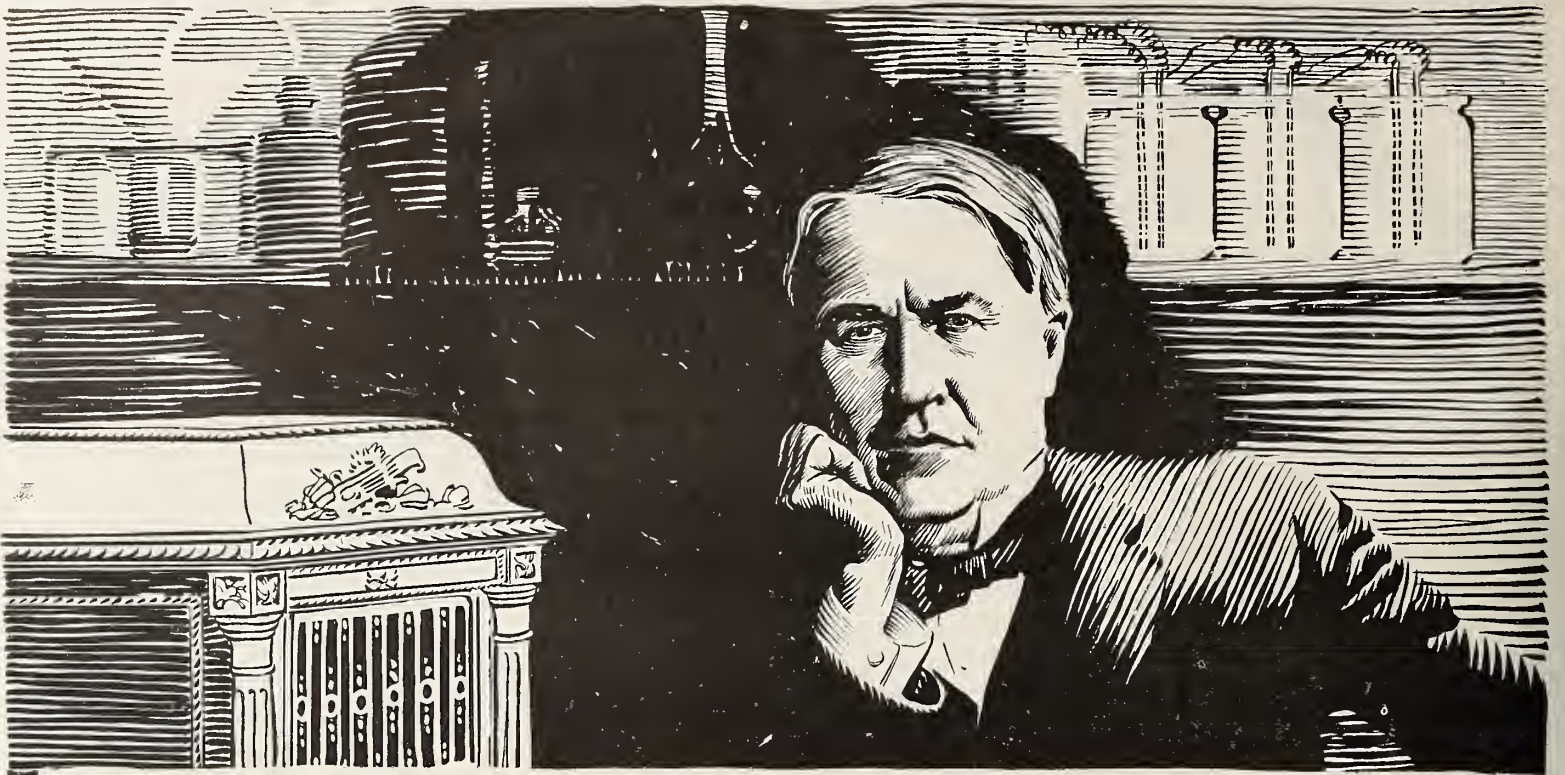

Big Business

*Great Opportunity Now For Dealers With New
Edison Diamond Disc Phonographs*

THE phenomenal success of the new Edison Diamond Disc Phonograph spells "money" for the dealer who does not need a telescope to see tremendous opportunity at his very door.

Its advent has astonished and delighted the music loving world and given the industry new life and renewed enthusiasm.

Here—at last—is an instrument that reproduces music with all the unblemished art of the original—with almost unbelievable tonal qualities—perfect, beautiful, incomparable.

Its selling qualities and arguments are without answer.

Just let it play itself into the hearts of your customers. Its music is simply irresistible.

Get in touch with us at once. Don't delay another day.

New Weekly Record Issues

INSTANT SERVICE TO ALL DEALERS

The New Weekly record service inaugurated by the Thomas A. Edison Co. is a great boon for the Edison dealer.

It brings your customer into your store every week—it brings him closer to you—makes him a real asset for you.

We can get the records ten hours after they are shipped from the factory at Orange. We get them first. We are prepared to give you **instant service**.

You can't give good service unless you get it. We are prepared to give it. Write or telephone to-day for information. Don't delay another day.

THE PHONOGRAPH CORPORATION OF MANHATTAN

443 BROADWAY, NEW YORK CITY

PHONE, SPRING 1320

For
COLUMBIA DEALERS
Salter's Trade Maker, No. 112

Everybody gets the "buy fever" when they see this handsome combination set up on your sales floor or in your window. It looks to be so much more expensive than it really is that people are easily sold when they find out the low price.

This Machine and Cabinet Match Perfectly

in design and finish. Felt lined compartments afford protection, records are easily accessible, there is a convenient filing index and many other features that simply argue their way in your prospective customer's pocketbook.

This is already a very popular combination, and the holidays will see them going like "hot cakes." Protect yourself against forgetfulness by getting out your catalogue and ordering *Now*. If you haven't a catalogue your postcard will bring one.

SALTER MFG. CO.
 339 N. OAKLEY BLVD.
 CHICAGO

A Sales Booster!



SALTER CABINET
 No. 112
 With Columbia "Favorite"

A HANDSOME DEPARTMENT

In the Progressive Store of House & Herrman, Wheeling, W. Va.—Possesses the Real Inviting Atmosphere Essential to Success.

(Special to The Talking Machine World.)

WHEELING, W. VA., September 10.—One of the most attractive Columbia graphophone departments in the State is that in the department store



Columbia Department of House & Herrman, Wheeling, W. Va.

of House & Herrman, Twelfth and Market streets, this city.

The department is located on the first floor and from the outside you see a dainty little shingled cottage done in brown and white with thatched roof and brick chimneys (just to top off the effect); tiny, diamond-glazed sashes complete the idea; vines are seen growing up the corner trellises and branch out over the shingles, adding color; boxes of geraniums, etc., adorn the window

ledges and growing flowers abound. Doors are in keeping with the entire construction. Stepping inside we view furnished rooms, complete and luxurious enough for any home. The walls are decorated in pleasing fashion with prettily designed wall covering; the draperies are equipped with blinds and window openings of exquisite color and design; your feet tread upon expensive rugs laid on hardwood floors. Then you can sink into the recline of a "comfy chair," and while dreaming into the eyes of some charming opera star (whose portrait adorns the wall) you may at once hear the voice of the living artiste until you are completely enraptured.

The clever arrangement is the idea of the department manager, Walker Allen, a dapper little Englishman with a host of friends both in this country and Great Britain, and who, in addition to a keen business sense has a most engaging personality. The Grafonola department is under the direct management of Allen D.

Browne, who has been most successful in developing the business.

In addition to a complete stock of machines at all times the department also carries about 12,000 records in its extensive record rooms.

VICTROLA FOR HIGH SCHOOL.

The high school at Warsaw, Ind., recently decided that a talking machine was decidedly essential to

its musical equipment, and it was accordingly arranged for the High School Glee Club to give a concert, the funds from this recital to be used for the purchase of a talking machine. The concert proved an emphatic success and a vote of the students resulted in the selection of a Victrola XI, to be purchased with the fund for the school's entertainment.

THE VICTROLA IN SONG.

"They Start the Victrola," the Title of a New Popular Song That Is Now Going the Rounds.

The recognized pinnacle of popularity for any article is to have a cigar named after it or to have a popular song written about it. In this connection it is interesting to note that there is a "Victor" cigar, and what is more important, a new popular song entitled "They Start the Victrola" (and go dancing around the floor) is now being whistled around town. The song, which is tuneful in a sort of way, is written entirely around the pleasure given by the music of the Victrola, the words being by Grant Clark and music by Maurice Abrahams. The song is being used extensively on the vaudeville and burlesque stages and is an original, interesting although unsolicited advertisement for the Victrola.

VALUABLE ADJUNCT FOR DANCERS.

(Special to The Talking Machine World.)

DAYTON, O., September 5.—The Soward Music Co., of this city, Victor representative, recently loaned a Victrola and some Victor records to the International Association of Dancing Masters for use at their convention, which was held in Dayton. In thanking the company for the use of the machine and records, Benjamin B. Lovell, president of the association, wrote in part as follows: "We find the Victrola a very necessary adjunct in teaching the latest dances, as the time is absolutely correct and their (the Victor Co.'s) collection of new dance records is wonderful."



**For quality, variety, interest and activity,
the Columbia Record List for October
is a symphony!**



(Write for "Music Money," a book "full of meat" for those dealers interested in quick and frequent turnover of capital.)

Columbia Graphophone Company
Woolworth Building, New York

OPTIMISTICALLY INCLINED IN ST. LOUIS TRADE.

Steady Improvement Over Corresponding Months of Previous Years Reported by Leading Houses—Jobbing Orders Show Increase—Expansive Trend in Remodeled Warehouses—Recital Hall for Silverstone Co.—Vacations at End and Activity on All Sides.

(Special to The Talking Machine World.)

St. Louis, Mo., September 9.—Local talking machine men have not shared in the pessimistic views of the business situation that have been so general. Neither war nor drouth has affected them seriously, although they have at times had doubtful views of the future, but as quickly as the period looked forward to has arrived these views have changed. Steady improvement over corresponding months of previous years has been shown by totals. The records of several stores are exhibited to show not only more sales but a higher average of sales than a year ago. Jobbing orders from the more distant trade territory have been excellent during the early fall season, and since the rains of the last three weeks the near-by trade has improved. The country within 22 miles of St. Louis has been the driest in the entire country all summer, and as it is largely a dairy country and garden produce district, it has improved rapidly even under late rains.

The record situation is rather peculiar just at present, in that there is practically no feature to the trade, although the volume is rather high. Popular songs, of course, are leading, but the variety of these is wide and they can hardly be called a feature. The dance craze did not survive the extremely hot weather, but is expected to begin again with the fall months. The European war has not created any demand for patriotic songs or music of those countries, as was expected.

There could hardly be better evidence of the expectations of the local talking machine trade than the material changes in stores that are under way or have been completed for the fall season. The Columbia store remodeling has been told about. The complete remodeling of the demonstration rooms of the Silverstone Music Co., with the addition of a concert hall, is under way.

Now comes Aeolian Hall with two large demonstration rooms on the handsome first floor of the

warehouses, heretofore held sacred to grand pianos and pipe organs. The Victrola department has been in the basement, but it has outgrown its quarters and the spacious room on the first floor is the result.

Next door is the Thiebes Piano Co., where four main floor demonstration rooms are being made into six, all of ample size for record demonstrations. The first rooms were planned before it was thought possible to get machine customers to the upper floors. Since the sale of a talking machine has assumed the dignity of the sale of a piano, all machine customers are taken to the fourth floor, where there are excellent demonstration rooms and an ample stock of three makes of machines, assorted as to price. The six rooms are designed for demonstration of records for a single customer, and during the busy season their need has been apparent time and again, when overflow record customers have seized upon every bit of available space on both the main and fourth floors.

The Story & Clark Piano Co. has been conducting a special sale of pianos to make room for the stock of Edison talking machines that have been ordered and which will be installed early in the fall.

Albert Engleman, of the repair department of the Silverstone Music Co., was married the first of the month to Miss Gussie Rumping.

E. S. Davis, of New Madrid, Mo., and Mr. Lutes, of Lutes & Feeney, Poplar Bluff, Mo., Edison dealers, were recent visitors here.

F. G. Seager, who has been manager of the Victor department of the Vandervoort Music Salon since it was established, has gone to New York, where he is employed by Silas Pearsall. A definite appointment of a manager has not been announced, but in the meantime Robert Shiverick is in charge.

Harry Levy, manager of the talking machine department at Aeolian Hall, spent his vacation in

the Ozark country, at Schlicht, Mo. Mrs. Levy accompanied him, and they enjoyed their time in surroundings that were truly rural.

Mark Silverstone, president of the Silverstone Music Co., has been suffering with a belated but violent attack of hay fever, which the fumes of the paint used in the remodeling of the interior of his main warehouse has not helped at all. Mr. Silverstone, to get this work done during the dull season, gave up his idea of a vacation and took relaxation by personally conducting his small son on frequent visits to the moving picture shows and imagining that they were visiting the countries shown. But the workmen got behind and the work will run well into this month, upsetting very generally the plans made for the opening of the early fall trade.

The chief feature of the new arrangement is a recital hall where there will be a continuous concert to demonstrate the Edison machine and the new records on the weekly list, or older numbers by request. The recital hall takes the place of two large demonstration rooms on the main floor and is built on the principle of a passenger car in outline, with the curved roof and ends. It will be furnished with large wicker chairs, which in informal arrangement will accommodate 30 persons, but there will be a reserve of small folding chairs which will permit almost as many more persons to be seated. On special occasions other seating arrangements can be made, as the warehouses are liberally supplied with folding chairs and mission settees. The decorations of the hall at the stage end will be of art glass in musical designs. This has not been placed at this writing; neither have the additional demonstration booths that are to be built for private demonstrations been constructed, so it will be some time before the warehouses are entirely ready for the fall campaign.

I. W. Reid, manager of the Columbia warehouses, returned the first of the month from a trip in southeastern Missouri much encouraged for the fall prospect. He had heard much of the damage of the drought in this section and the discouragement of the country folk and merchants, but he found the condition very different. Heavy rains that effectually broke the drought just before his trip had put everyone in good humor and had greatly improved the prospect for fall by insuring pastures and much fall produce. While the rains were too late, he learned, to be of much benefit to the corn, he was informed that if the fall was reasonably late the heavy pastures would greatly relieve the feed situation.

He also was much encouraged on his return from the East to learn of the reception by the trade of the remodeled Columbia store and of the boom it had given to the retail business, especially the record business, which had held up well during the remodeling period.

Sales Manager Duffy, of the Columbia warehouses, has drawn up an attractive announcement for his customers to call attention to the new store and to present the advantages of the Columbia line.

Because a man believes in the \$ sign is no sign he is superstitious.

It is quite possible to eliminate the sting from a joke and still retain its point.

"Standard" Record Cleaner

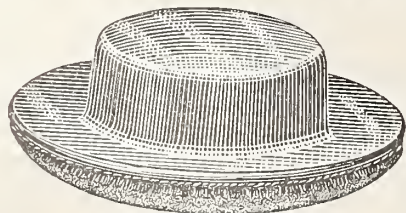

Price, 50 Cents, List
Patented June 2, 1914.

Send 10 cents in stamps for a sample cleaner. Write on your business letter head only. Place regular orders through your jobber.

ARTISTIC AND ATTRACTIVE

**Grips the record surface and
clings as if on rails.**

**Extended brush area cleans record
with one sweeping circuit.**

STANDARD GRAMAPHONE APPLIANCE CO.

173 LAFAYETTE STREET,

NEW YORK

For
EDISON DEALERS

Salter's Trade Maker, No. 180

Here's a Cabinet that any woman who appreciates the good things of life will simply "rave" about. It provides the living room or parlor with a handsome, harmonious piece of furniture, has the *appearance* of being expensive, and is *worth* a great deal more than the low price we ask for it.

You'll Be PROUD To Sell It

Your customers will be proud to *own* it—and it will give service and satisfaction that will be most gratifying to the person *who buys* it.

The felt lined compartments and ease of record selections are other winning points that make *sales easy*.

Our special booklet showing Salter Cabinets in use with Edison Disc Machines is yours for the asking.

EARLY BUYING IS ADVISABLE

We are already loaded with holiday orders—Write to-day.

SALTER MFG. CO.

339 N. OAKLEY BLVD.
CHICAGO

It Sells Itself!



SALTER CABINET

No. 180

With Edison Disc No. 80

EXCLUSIVE VICTOR DISTRIBUTER.

Koerber-Brenner Music Co. Gives Up Extensive Musical Merchandise Department to Give Undivided Attention to Its Rapidly Increasing Talking Machine Business.

(Special to The Talking Machine World.)

St. Louis, Mo., September 8.—The Koerber-Brenner Music Co. announces that its firm is now an exclusive Victor talking machine distributor. It is probably the largest house in the West confining its dealings to the jobbing of this line of goods. The Koerber-Brenner Music Co. was known for years as one of the leading small musical goods jobbing houses in this section, and its trade territory includes many Western States. During the cylinder talking machine days it added both Victor and Edison lines as a part of its small goods stock.

The first move toward its present position as exclusive jobber was the dropping of the Edison line about two years ago. Its stock of these machines was sold to the Silverstone Music Co., and Mr. Silverstone, a Victor customer of the Koerber-Brenner Co., gave up the Victors and became an exclusive Edison house. Recently the Koerber-Brenner books have shown that the business was running more and more to talking machines, and instead of a side line to musical merchandise they were making the small goods the side line. The business in this department has not a small one, either, as any person who has had the good fortune to see one of the handsome catalogs of the company must know. It carried an extensive line of all stringed instruments and novelties and commanded a high position in the Western trade. But this prestige did not blind them to the fact that the money and the growing business was in the talking machines, and so the small goods were sacrificed. Now the line is exclusive Victor goods, and because of the heavy stock it carries for its growing trade it requires as much ingenuity on the part of the stockkeeper to handle it as it did when there were 1001 items

of small goods. Both Mr. Koerber, president and treasurer of the company, and E. C. Rauth, vice-president and secretary, have mastered all details of the talking machine trade and have gone to see the instruments made in the factory, and are enthusiastic believers in their line. Mr. Rauth has for several years been prominent in talking machine jobbers' association work.

NEW COLUMBIA "METEOR."

Latest Addition to the Line of Columbia Machines to Sell at Low Price—Some of Its Interesting and Distinctive Features.

The Columbia Graphophone Co. announced last week an addition to its comprehensive machine line in the nature of a machine designated as the "Meteor," which will retail at \$17.50. As will be



The Columbia "Meteor."

seen by the accompanying illustration, this machine, which was built to meet the demand for a Columbia machine to retail at less than the "Eclipse" at \$25, is entirely in keeping with the attractive appearance of the many other machines in the Columbia line.

In a circular sent out this week the following constructional specifications are noted as applying to the "Meteor":

Cabinet: quartered golden oak; measurements, 13 inches wide by 14 inches deep; metal finish: all exposed metal parts heavily nickel-plated, with exception of tone-arm bracket, which is japanned; motor: one-spring drive, non-varying, non-vibrant;

motor-control: speed regulator operated on graduated dial combined with start and stop device; needle equipment: 200 full-tone needles; tone-control: Columbia tone-control leaves, operated by a button in the front pilaster, also by variety of needles; tone-arm: new bayonet-joint tone-arm of one-piece, seamless, drawn-tapered tubing; reproducer: with smooth aluminum diaphragm.

NEW INCORPORATION.

The Religious Picture Corporation, New York City, has just been incorporated for \$30,000 by F. D. Stoba, W. P. Powell and A. W. Britton, for the purpose of carrying on a moving picture and talking machine business.

ARTHUR D. GEISSLER RETURNS.

Arthur D. Geissler, vice-president and managing director of the New York Talking Machine Co., 81 Chambers street, New York, Victor distributor, arrived in New York last week on the steamer "Campania," after having been marooned abroad for a few weeks owing to the war. Mr. Geissler, who was accompanied by Mrs. Geissler, passed through a number of annoying experiences, which made the Statue of Liberty in New York harbor a most welcome sight.

OPENING FOR TALKING MACHINES.

In an informative article in last week's *Printers' Ink*, under the title of "European Trade in United States That Is Subject to Capture," a writer points out that Europe sent us last year only \$35,000 worth of talking machines and phonographs, and continues as follows:

"On the other hand, the music loving Latins of the Pan-American countries have been wont to distribute their purchases of talking machines and records among American, English, French and German houses, whereas henceforth American interests should have almost a monopoly of this business."

NEW YORK TRADE IN SATISFACTORY SHAPE.

Local Jobbers and Dealers Report that Business Is Keeping Up Well Despite Setback Caused by War Situation—Everyone Optimistic Regarding the Outlook—What the Various Concerns Are Doing to Capture Sales—New Dealers Enter the "Talker" Field.

The talking machine trade in local circles the past month has been generally satisfactory, though here and there some of the dealers report a falling off of business as compared with last August, due no doubt to the direct influence of the European war on their clientele. As a matter of fact, practically all lines of trade in New York have fallen off the past month, some materially and others in a lesser degree. In view of the existing conditions as a whole, the "talker" trade is considerably ahead of the average mercantile line, and as one distributor aptly put it, "bears a charmed existence."

The European war is undoubtedly exercising a more apparent influence upon New York business than any other city in the country because of the intimate relationship existing between so many firms in this city and the countries engaged in conflict, in addition to the fact that New York is by far the greatest import and export center in the country and therefore the first to suffer from any cessation or lessening of this trade. Dealers in the adjoining suburbs who cater to a clientele consisting largely of factory workers in several instances report a direct loss of business and collections as a result of the war abroad, this influence being caused by the closing of factories in near-by towns whose shipments to European markets formed an important factor in their business. On the other hand, talking machine dealers in residential cities have had no occasion to feel the effects of the war and report a very gratifying August business, in most cases ahead of that of August, 1913.

The Outlook Is Encouraging.

The outlook as a whole is decidedly encouraging, as jobbers and dealers unite in the prediction that this fall will be one of the most prosperous seasons in the history of the industry. September business has already started in strong, and there is every indication of the record business in particular breaking all high-water marks. Aggressive advertising campaigns are being planned by the active members of the trade, and judging from the care and consideration being given this publicity, the advertising of the local trade the next few months will be worthy of particular attention.

It is the consensus of opinion among the leading jobbers that the small dealer will show the largest increase in business this fall, rather than the department store or the very large retailer. The small dealer has been conserving his energy and efforts for the fall and winter seasons, and as a result has started his campaign with vim and vigor. He has not overstocked during the spring and summer months, and is therefore in a position to place substantial orders for machines and records and, what is more important, is ready to dispose of these shipments promptly.

Why Bolton Is Enthusiastic.

R. F. Bolton, manager of the Chambers street headquarters of the Columbia Graphophone Co., 89 Chambers street, is enthusiastic over the fall outlook, basing his optimism on the orders now on hand and the results accomplished the past few months. Commenting on business conditions, Mr. Bolton said: "We have every reason to feel gratified with the prospects for fall and winter trade, as our summer business was excellent and the first week of September has been up to all expectations. Our August trade held its own with August, 1913, which, in view of the conditions resulting from the war, is a better report than the statement may indicate. Our business last month was of a somewhat higher grade than that closed the corresponding period last year. The new 'Meteor' machine introduced a few weeks ago is meeting with a splendid reception, and our dealers predict a banner sale for this machine during the next few months."

Blackman's Good August Month.

J. Newcomb Blackman, president of the Blackman Talking Machine Co., 97 Chambers street,

Victor and Edison cylinder distributor, is confined to his home with a serious attack of typhoid fever. Although Mr. Blackman is on the road to recovery, it will probably be more than six weeks before he has convalesced sufficiently to resume active duties. In Mr. Blackman's absence Vice-President Caldwell has been directing the destinies of the Blackman Co., and the activities of the company's dealers is well evidenced by the fact that August business showed a nice increase over that of last August in both machines and records. The No. 10 Victrola is proving a special favorite with Blackman dealers, who are presenting the merits of this machine in an impressive and result productive fashion. The Blackman Co. has on its books many comparatively small dealers, and it is encouraging to note that these dealers are placing advance orders that average up considerably higher than those placed at this time last year.

New Edison Shop Near Completion.

The new Edison Shop at Fifth avenue and Fortieth street is rapidly nearing completion and all indications point to its being ready for formal opening by the first of next month. As the new home of the Edison products, this building will be one of the centers of the local retail trade, and the high standards being maintained in its interior and exterior decoration will be readily appreciated by the shoppers on Fifth avenue, who are keenly alive to the value of dignity and refinement in preference to the gaudy and the glaring. The location of the new Edison Shop is most advantageous, and the opening next month will be in time to reap the opportunities of the usual Fifth avenue fall trade.

Cowperthwait's Expanding Trade.

One of the many Columbia representatives in this city which is closing a very fine business is Cowperthwait's, the prominent furniture house, which is carrying the Columbia line in both of its stores. Under the able management of Edward Wooley, who is in charge of the departments at both stores, Columbia sales have steadily increased from the first week the departments opened and, backed by a forceful advertising campaign, Mr. Wooley is planning to make the fall a winner in every sense of the word.

New Victrolas Favorably Received.

"The new Victrolas X and XI are being most favorably received by all our dealers and are praised by their patrons generally," remarked G. T. Williams, manager of the New York Talking Machine Co., 81 Chambers street, Victor distributor. "There has also been a good, live demand for dance records the past month, and with the return of the vacationists the call for this class of music will naturally be transferred to the dealers in the large cities, who have had a temporary lull in dance record music while the dealers in the country resort towns were securing the orders. The business outlook is most encouraging and all of our dealers are optimistic to a marked degree. Our August business showed a substantial increase over last August, and in that respect we continued our sales record since the first of the year, in that we have exceeded 1913 business month for month. When it is realized that 1913 was our record-breaking year, the true extent of the 1914 sales may be appreciated."

New Columbia Representatives.

Quite a number of new representatives in nearby and local territory have been added to the Columbia Co.'s books the past few weeks, including among others the following concerns: Ludwig Baumann & Co., 49 Market street, Newark, N. J.; F. C. Kraemer, 8 Lincoln street, Jersey City, N. J.; L. W. Caldwell, Troy, N. Y.; J. Solow, 1116 Avenue J, Brooklyn, N. Y.; Daniel Cantor, 917 Freeman street, New York, N. Y.

Ormes Succeeds Sol Bloom, Inc.

The Victrola store located at 366 Fifth avenue, which has heretofore been operated under the firm

name of Sol Bloom, Inc., last week changed its name to Ormes, and will be known by this name in the future. There is no change in the personnel or policies of the store, O. K. Liveright being the manager. The company formerly co-operated with another store at Fortieth street and Broadway, but this was closed recently, Mr. Liveright desiring to concentrate the business in the Fifth avenue store.

WILL SEND TRADE AGENTS.

Department of Commerce Announces Its South American Plans.

(Special to The Talking Machine World.)

WASHINGTON, D. C., September 8.—The Department of Commerce last week issued an announcement of the plans for the development of the South American trade. The announcement read in part:

"The department will promptly undertake the establishment of both a permanent and traveling force in South America. This force will consist of men familiar with the language, customs and business methods of Latin America, who have had practical experience in various lines of business carried on with Latin-American countries.

"Four of the department officers will be commercial attaches, for which provision was made by recent legislation. They will be assigned to Rio de Janeiro, Buenos Aires, Santiago and Lima. It is hoped to have these officers at their posts by or before October 1.

"In addition to these, six traveling commercial agents will be promptly dispatched to South America and will, in their travels, cover all the commercial areas of that continent. These will include specialists in hardware, textiles, lumber and other industries, and arrangements will be made also for a general study of any commercial and industrial opportunities that may open in favor of American interests."

CARD INDEX A GREAT AID.

C. S. Donaldson, chief of the consular division of the bureau of foreign and domestic commerce, has uttered a word of advice, based on long experience in public work in Washington. "Probably everyone," he declares, "can recall what a loss certain business concerns have sustained through the death or resignation of an important official. His fund of knowledge was wonderful, his recollection of detail was invaluable, which made his mental storehouse a tangible asset to the company. Recourse has even been made to insuring his life.

"A business house will do much better if it will insure the possession and preservation of the major part of that accumulated knowledge. The best storehouse for it is the card reference system, which places it automatically at hand for every emergency, and every forward step.

"In a large concern where it has not been developed I would suggest that the card index system be made most extensive, a running diary in fact of all the phases of transactions within and without. A new man comes into a concern as business manager and lack of knowledge of these things handicaps him and also causes him to lose valuable customers."

GAVE RECITAL FOR TEACHERS.

Manager J. D. Bunce, of Grinnell Bros. Branch in Hillsdale, Mich., Takes Excellent Advantage of Excellent Opportunity.

(Special to The Talking Machine World.)

HILLSDALE, MICH., September 5.—At the recent examination of the county school teachers, held in this city, J. Dwight Bunce, manager of the local branch of Grinnell Bros., took advantage of the opportunity to place a Victrola in the auditorium and give a recital that was much appreciated by the 148 teachers present. The tones of the Victrola filled the large auditorium and held the attention of the audience until the "Star-Spangled Banner" was played at the end. Following the recital a twenty minute talk on the value of the Victor in the schools was delivered by Mr. Bunce and aroused much interest.

Better Than Ever This Year

WE are able to take care
of your business.

ON HAND—the largest stock
in our history—

A COMPLETE STOCK.

Send us that Advance Order
now.

New York Talking Machine Co.

81 Chambers Street, New York City

“THE COUNTRY’S GREATEST VICTOR DISTRIBUTOR.”

"The Player-Piano Up to Date"

That name sounds good, does it not?

Well, it fittingly applies to the latest work upon the player-piano. Every salesman can increase his earning capacity by a perusal of this book, and it should be within easy reach at all times. It is a sales booster.

A salesman can talk the player more intelligently and he can explain its parts convincingly.

Within the covers of this book is a fund of information which is valuable to everyone interested in the player trade, whether manufacturer, dealer, salesman or regulator.

The practical part relating to adjustment and use of pneumatic mechanisms is decidedly interesting.

The book is divided into five parts. Here is a summary of what each part contains:

- Part 1. The Fundamental Principles of Pneumatic Mechanism (an explanation of the physical laws involved, with their application to the matter at issue, illustrated with sketches, tables, etc.).
- Part 2. Practical Player-Action Building.
- The pressure-reducing apparatus or bellows.
 - The striking action (pneumatics, valves).
 - The motor.
 - The mechanism of control.
- Part 3. The Music Roll. Principles, manufacture, various types. Illustrated.
- Part 4. Adjustment and Care of Player Mechanism. Hints to makers, repairers, tuners and owners.
- Part 5. How to Play with Expression Any Mechanism.
- Part 6. A Description of the Leading Mechanisms Now in Use.

Increase your earning capacity by adding to your knowledge of player mechanism.

It will cost you \$1.50 if you live anywhere in the United States to secure this book, and if you are not pleased with it after examination it is a money back proposition with us. You will get your little \$1.50 returned to you as quickly as the book will be forwarded to you upon receipt of that sum at this office, but you would not part with it for \$1.50 after you have once seen it.

Take our word for it!

EDWARD LYMAN BILL
PUBLISHER

373 Fourth Avenue, NEW YORK

IDEAL UNION IN INDUSTRY.

Co-operation Between Employers and Employees the Modern Spirit in Business, Typified in Industrial Safety Movement.

The new spirit of American business is typified in the recently formed National Council for Industrial Safety, which is urging the mutual interest of employers and employees as the basis of the ideal union in industry. Robert W. Campbell, of Chicago, its president, has summed up its aims as follows:

"The last few decades have witnessed three distinct periods or epochs in the political, social, economic and industrial life of the American people which may be described briefly as feudal or paternal, individualistic and co-operative, the second being a swinging of the pendulum from one extreme to the other. As civilization has advanced each step has placed our life on a higher plane, until to-day we who are on the threshold of the co-operative epoch find more of humanitarianism, more of kindness, more of mutual helpfulness, and more of the spirit of brotherly love evidenced in every phase of life.

"Co-operation is, fundamentally, a right doctrine. Religiously, it may be found in the teachings of practically every sect, and socially, economically and industrially it is daily establishing itself more firmly as a basic principle in the activities of the people. It is no longer a theory, but a condition which must be recognized.

"Co-operation may, of course, be used for evil as well as good, but the forces of evil can never proceed very far under its banner, for selfishness, personal interest, greed and graft found in evil causes, in which those interested are after everything and willing to give nothing, are not compatible or consistent with true co-operation. It would also seem that the worthier the cause and the higher the purpose, the more readily does co-operation lend itself to its fulfillment. This has been clearly demonstrated in many ways, but in none more positively than in the present accident-prevention movement.

"The spirit of 'Safety First' is typically a co-operative one, and two years ago those most interested in accident-prevention work believed that some agency should be provided which might make possible the highest degree of co-operation between those engaged in the common cause of fighting preventable accidents, and which also might co-ordinate the work being done, as well as stimulate further activity.

"The National Council is purely a co-operative organization in every sense of the word, co-operatively formed, co-operatively supported by the dues of its members; co-operatively managed by its executive committee of fifteen and its larger board of directors comprising the men most prominent and most efficient in the safety work of to-day, and co-operative in its activities in that each member is extended an ample opportunity not only to obtain aid, but also to provide it, as employers who are interested in the welfare and safety of their men find it a privilege to give other members the benefit of their experience and knowledge secured through safety work already done.

"The aim or purpose of the National Council as stated in its constitution and by-laws is 'To promote the conservation of human life and its incidents in the industries of the nation,' or more broadly, 'Safety First—Individual—Industrial—Public.' In brief, the aim of the National Council is to provide an agency which may make possible a full measure of co-operation among its members and will stimulate greater activity along accident-prevention lines and will co-ordinate the safety work being done, thus as far as possible avoiding duplication of effort.

"Only a beginning has been made. The initiative in a movement of this character naturally rests upon the employer. The spirit of the times, legislative action and private conscience all are making early action more and more imperative. It is far better that such action should be taken voluntarily rather than under compulsion by legislation or of public sentiment to greater activity and to a larger effort in this humanitarian cause."



NYOIL

For polishing
varnished woodwork it is
extremely satisfactory. No oil is so clean.

Ask your watch repairer whose
oil he uses on your watch.

SECTIONAL RECORD CABINETS.

Ogden System of Record Filing Proves Most Convenient for Dealers—Cabinets That Grow as Needed—Signal System That Makes It Easy to Find Records—Other Advantages.

A talking machine accessory that is continually making new friends among talking machine dealers is the "Ogden" sectional record cabinet, made and marketed by J. B. Ogden, Lynchburg, Va. One of the chief advantages of the Ogden filing system is the fact that, being built on the order of the sectional bookcases that have long been familiar to the public, it has all the advantages of those pieces of furniture combined with a number of original features for this particular trade. The sectional idea attracts owing to the fact that, as the record library grows, it is possible to add section after section without having waste cabinet space in evidence or several record cabinets placed about the room. The cabinets are supplied with special top and bottom parts, and from one to four or more sections may be added at will, with the whole having the effect of being a single and complete piece of furniture.

A special feature of the Ogden cabinets that appeals particularly to the dealer is the signal system, distinctly original in character, and which makes it a simple matter to find any desired record in a few seconds. A drawer in the base of the cabinet is also equipped with an automatic reordering system that serves to aid the dealer materially in keeping his stock up to date. There are many other features of the Ogden sectional record filing cabinet worth knowing about.

ADVERTISING THAT INTERESTS.

The very striking and cleverly arranged publicity which is being carried in The Talking Machine World by the Koerber-Brenner Co., Victor distributor of St. Louis, is attracting considerable attention. It demonstrates that this house is getting after business in a thoroughly progressive manner, that it is "alive" to the needs of the territory which it covers, and this publicity imbues dealers with convincing proofs that an alliance with this house is one that will be most beneficial and profitable. An idea of the central position occupied by St. Louis as a shipping center is pleasingly illustrated in the map which appears in the Koerber-Brenner advertisement elsewhere in this issue.

DE ANGELIS IN CHARGE.

John De Angelis, a cousin of Jeff De Angelis, the comedian, has been secured this week to take charge of the talking machine department of the Cunningham Piano Co., Philadelphia, Pa., where the Edison is handled exclusively. Mr. De Angelis comes from Winnipeg and has represented the Edison Co. on the road.

Loose Leaf Photo Albums OF REAL MERIT

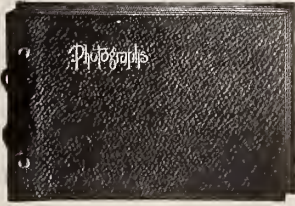

Loose-Leaf Album, Genuine Leather Seal Grained Covered, 50 leaves in each book. Black seal grain leather cover, flexible, silk cloth lined, gold stamped, open back, carbon black leaves, black silk cord. Telescopic tube expansion to almost double.

Our Complete Line of Photograph Albums enables the dealer to offer his customers albums of unsurpassed quality at the most reasonable prices. Our albums, both the loose-leaf and the permanent-bound styles, are constructed with great care and the best of materials are used. A loose-leaf album, our specialty, has so many good features that it is bound to grow. A book can be started with a small capacity and added to as the collection grows. Damaged leaves can be removed, leaves can be shifted.

We are making the most complete line of albums for **Victor, Columbia and Edison disc records on the market**, including the regular 16 or 17 pocket styles, and a new 12-pocket album, which adapts itself for use in the new cabinets with flat shelves. *Write for Full Particulars and Trade Prices.*



NEW YORK ALBUM & CARD CO., Inc., 23-25 Lispenard Street, NEW YORK

(Formerly New York Post Card Album Mfg. Co.)

A NEW FORM OF RECORD ORDER.

New York Salesman Is Handed a Few Bars of Music on a Scrap of Paper Instead of the Name or Number of the Record, But Runs the Clue to Earth in Short Time.

The live talking machine salesman must know the actual music on the various records in the catalog and be able to remember the airs, as well as know thoroughly the names and numbers of the new records and the artists who make them, as indicated by the experience of a New York salesman recently.

The salesman in question was approached by a young miss who tendered him an envelope which contained a \$2 bill and a small slip of paper on which was scored several bars of music, and which also bore the request that the record containing the music be delivered to the girl. The salesman studied the paper for a while and then took it to the pianist in the sheet music department adjoining, who played over the notes several times without affording a clue, for both pianist and salesman had ideas as to what record was referred to. The solution of the puzzle came when several of the most possible records were played over and it was discovered that the music, as scored, was found in the middle of the popular hit, "My Croony Melody." The solution appeared to be correct, for the record was given to the messenger and was not returned. Now the salesman is taking a course in sight reading as a further aid to his work.

RAVIS ELECTED VICE-PRESIDENT.

Philip Ravis, Well Known in Musical Merchandise Trade, Becomes Officer in New York Album & Card Co.—Plans Wide Distribution Throughout the Country.

Philip Ravis, well-known to musical merchandise dealers throughout the country, has been elected vice-president of the New York Album & Card Co., 23 Lispenard street, New York, manufacturers of talking machine record and photo albums. Mr. Ravis, who was connected with Buegeleisen & Jacobson, the prominent musical merchandise house, for eleven years, assumed his new duties this month, and is enthusiastic regarding the possibilities of the "talker" and photo album field.

Mr. Ravis returned this week from an extended trip, on which he closed arrangements with several travelers to act as representatives for the New York Album & Card Co., with headquarters in different cities that are the centers of their respective territories.

FRANK STORCK HEARD FROM.

R. B. Caldwell, vice-president of the Blackman Talking Machine Co., New York, Victor and Edison cylinder distributor, received a postal communication this week from Frank Storck, the well-known Victor dealer at Red Bank, N. J., stating that he was marooned at Munchen, Bavaria, with no hope of reaching a sailing port until transportation conditions improve.

C. J. IANNELL WITH LOESER & CO.

Now in Charge of Talking Machine Department of Prominent Brooklyn Store—Fall Prospects Excellent—Good Stock on Hand.

C. J. Iannell, formerly manager of the talking machine department of the Simpson-Crawford Co., is now in charge of the talking machine department of Frederick Loeser & Co., under E. Paul Hamilton. Mr. Iannell stated that the prospects for fall business in the Loeser department are decidedly bright with the higher-priced machines selling well. Careful ordering has also placed the record stock on a basis where it is possible to fill all record orders on close to a hundred per cent. basis.

NEW VICTOR MODEL XXV.

Latest Addition to the Victor Co. Line to Be Known as Type "A"—Some of the Features.

The Victor Talking Machine Co. announced this week a new addition to its machine line in the nature of an Improved Victor XXV, which will be designated as Type "A." This machine, which is used solely for installation in schools and educational institutions, is designed to retail at \$67.50, and embodies the following improvements over the Style XXV now on the market:

The turntable has been raised the same as in the Victrola types, making it accessible and easy to put on and take off the record.

The lid has a patent hinge, allowing it to be removed quickly and hung on the back of the instrument when being played, permitting the horn to be swung in any direction.

The shelf is hinged, so that it can be raised and the horn placed under the instrument safe and secure from damage when not in use.

The dimensions of the new Type "A" are slightly larger than the Style XXV now on the market.

Never let your mental reservation fall below the limit.

SILVERMAN WITH LANDAY BROS.

Well-Known Talking Machine Salesman to Act as Wholesale Representative for Prominent Distributors—Elaborate Wholesale Campaign Planned—To Be Vigorously Developed.

Louis Silverman, formerly connected with Thomas A. Edison, Inc., has joined the sales forces of Landay Bros., 563 Fifth avenue, New York, Victor jobber, as wholesale representative. Mr. Silverman, who is well known to dealers throughout Greater New York, is thoroughly familiar with the wholesale end of the "talker" business, and is well equipped to score a signal success in his new connection.

Referring to Mr. Silverman's appointment, Max Landay, of Landay Bros., stated that his company which had in the past handled a few select dealers' accounts in addition to the business of their own establishments, had greatly increased its facilities the past few months, and intended to make a bid for more wholesale business in proportion to its added facilities for handling these new accounts.

Mr. Landay stated further that the wholesale division of the Landay business would be taken care of by a separate and distinct organization that would take care of the dealers' accounts adequately and efficiently, with no desire to secure any more business than it could properly handle. Additional stock rooms of large dimensions have been erected at the Forty-sixth street headquarters of Landay Bros., for the use of the wholesale organization, and the Landay motor truck service will be used extensively in Greater New York.

The Victor Talking Machine Co. inaugurated its 1914 fall national advertising campaign through the medium of a striking center two-page spread in the September 5th issue of the Saturday Evening Post. Illustrated in colors, this advertisement was easily the most impressive in this magazine and served to attract the attention of readers from Coast to Coast.

Your Opportunity

50 cents stamps brings you a sample of our highly perfected Standard Fibre Needle Cutter.
25 cents stamps brings you a sample of our simple and accurate Standard Automatic Stop.

Samples sent only to bona fide dealers writing on their business letterhead. Place regular orders through your jobber.

STANDARD GRAMAPHONE APPLIANCE CO.

173 LAFAYETTE STREET

NEW YORK

UTILIZING THE WAR AS AN ADVERTISING MEDIUM.

How an Enterprising Talking Machine Merchant Can Attract Attention and Build Business from the Delivery of War News a la Phonograph—Appealing to the Greatest Interest of the Public in an Original and Effective Manner—Some Live Suggestions.

Now that the European conflict is nearing a crisis war news is more popular even than the tango, and not only between our citizens of the masculine gender do we hear heated discussions as to the ultimate result, but among the gentler sex as well. As a matter of fact, Uncle Sammy's whole durned family has given up the three step to talk war. Therefore, Mr. Dealer, it is distinctly up to you to bring forward some scheme whereby you may meet this condition and at the same time get some more money and new customers, both of which, believe me, are most desirable.

Did you ever mingle with the throng in front of a newspaper bulletin board and absorb the news as it came sizzling over the wire? If you have done this thing you already know how tense becomes the situation when a particularly overwhelming item is displayed, and how the crowd cheers and stamps in its wild enthusiasm.

If you would have the crowd perform similar stunts in front of your show window, Mr. Dealer, you will serve them with war news a la phonograph. It is not so much the fact that you are turning your shop into an information bureau that will attract attention, but rather the method employed. Anything savoring of novelty will always

draw a crowd, and because your war bulletins are spoken by a talking machine instead of being displayed in printed form, as is the usual custom, will act as a magnet toward a curious multitude, a great many of whom will eventually become your patrons.

This method of utilizing the current European disturbance as an advertising medium is not nearly so difficult as it would appear at first sight. My friend, John Jones, expert at the art of dispensing "talkers," goes about it something like this:

He has three large horns arranged with their bells protruding outside his window, as shown in the silhouette illustration accompanying this story. They are all connected to the sapphire pointed reproducer of an Edison Triumph phonograph. This reproducer is equipped with a very loud diaphragm and the records are made by a robust voice. As a result the volume of sound that issues from this triumvirate of brass trumpets can be heard from afar. He does not go to the expense of having a special wire installed from which to glean his information. He simply keeps the office boy hustling between the nearest newspaper office and his "talker" emporium, and the clerk with the robust voice stationed at the recording horn.

When a lull occurs in the stream of advices from abroad he runs off a few records engraved with martial music rendered by bands and orchestras representing the countries now at war. For instance, first will come a military march by the Coldstream Guards Band of London, England. This will be followed by a selection from the Garde Republicaine Band of France. The Strauss Orchestra of Germany will then play a national hymn, etc. This musical congress of nations will last until a new war bulletin is ready.

To illustrate how a phonographic reproduction of any happening involving the playing of military bands will make an instantaneous hit with the public



The Phonograph Bulletin in Action.

I will refer you to the Peace Jubilee in Philadelphia immediately following the Spanish War. An enterprising dealer of that city sent an operator out upon the street with an Edison phonograph and some blank cylinders to can the parades. While he was only successful to a minor degree—the records being very weak in volume—the fact that they represented a genuine procession in celebration of a national event, and not a laboratory imitation, made them sell like hot cakes, and hundreds more than he was able to procure could have been disposed of at a most satisfactory price. This being true, Jones says that if a dealer will give the public a few news items relating to the war, interspersed with good ringing tunes by European bands, he will draw crowds and make money, and I am inclined to believe him. What do you think about it, Mr. Dealer?

Now, to be perfectly frank, do you know exactly what the war is about? Are you in a position to give in a clear and concise manner a description of the causes leading up to the present conflict between the Teuton and the Slav? Can you tell your patrons in about four minutes' time all there is to know upon the subject, and do it in a manner so simple and yet so convincing that they will not only thoroughly understand, but remember? It would be fine, indeed, if you could do this, for then we would not be called upon to ask the aid of the manufacturers, as we are about to do. Unfortunately, however, the average talking machine dealer cannot talk war as successfully as he can sell records; therefore, we must appeal to the recording laboratories to do it for us.

In the interests of all concerned, I suggest that a talking record be listed at once setting forth in clear diction the causes of the present war. Have you paid particular attention to the way Harry E. Humphrey's voice sounds on a record? Have you listened to his speeches on the blue amberol, and his descriptions of operas on the reverse sides of Edison operatic discs? If so you will agree with me that Mr. Humphrey is the man to make this record.

Mr. Manufacturer, you cannot fail, I am sure, to realize, now that the matter is brought to your attention, how badly a record of this kind is needed. It will prove of the greatest possible assistance to the dealer in the sale of records for this reason, viz.: Every talking machine man is pushing foreign records, or at least he should be doing it, and when he puts a record of the March Lorraine, named for a French town which has been in the thick of the fighting between the French and Germans, upon the mandrel, the patron recognizes the title as that of a city within the war zone and

PREPARE FOR WAR ON THE HOLIDAY BUSINESS

Every LIVE DEALER is preparing for the HOLIDAY BUSINESS, which will soon be on us.

**"TO BECOME A
BLACKMAN DEALER
IS TO
BE PREPARED"**

(BLACKMAN)

The first step to become a "BLACKMAN DEALER" is to send a few trial orders. "BLACKMAN SERVICE" will hold you.

BLACKMAN TALKING MACHINE CO.

J. NEWCOMB BLACKMAN, Pres.

97 CHAMBERS ST., NEW YORK



starts to ask questions. A general discussion of the European situation follows and finally comes the inquiry, "What is it all about, anyway?"

How decidedly satisfying to have that talking record to tell the story for him; not in the haphazard fashion he himself would render it, but in the sparkling and perfectly enunciated style of Mr. Humphrey.

"Oh, that's fine!" cries the patron enthusiastically after hearing it played. "I must have that by all means. Why, would you believe it, I never knew before I heard that record a thing about the fine points of the war. Yes, wrap it with the others, please."

That is the way it works out, Mr. Manufacturer, and do you not agree with me, now that I have endeavored in my poor way to make it clear to you that there is a crying need for such a record today?

It should be forcibly impressed upon the mind of every talking machine dealer at this time that the exploitation of selections rendered by bands representing the warring armies will bring increased business. There are many instrumental selections in the catalogs of the different record makers that are seldom given the attention they deserve because they are not played by the musical organizations of our native land. I know by experience, after an extensive investigation, that even now at this propitious moment foreign band records are not being pushed. Now that a great European war is in progress this neglect of foreign records is not only a grave error, but a detriment to big business.

Mr. Dealer, look over your foreign catalogs this very day; pick out the records of martial airs rendered by the bands now at the front with the various armies, embody them in an artistic booklet with a scrappy cover on it, together with a brief description of the history of each band, and send it out among your customers. Your business will take a mighty stride forward the minute this suggestion is acted upon. Take a chance and be convinced.

This booklet idea applies not only to Europe, but to Mexico as well. Owing to the fact that Carranza insists upon making ugly faces at our Uncle Sammy, that the American fleet is to remain at Vera Cruz for an indefinite period and that General Funston has asked for more troops the Mexican situation is still a subject of vital interest, and the demand for records by the Banda de Policia should be sent soaring upward by a little judicious advertising via the scrappy brochure route. I would certainly suggest, Mr. Dealer, that you reserve at least one page of that booklet we have been talking about for our neighbors on the other side of the Rio Grande.

All of us realize only too well that war is all Sherman said it was, and then some. However, if it is possible to utilize it as an advertising medium for the betterment of one's business it would be the worst sort of judgment to let the opportunity pass by unquestioned. Here's hoping that the old saying, "'Tis an ill wind that blows no one good," may prove true as related to the war and the "talker" trade.

HOWARD TAYLOR MIDDLETON.

NEW STYLE LONG CABINET

Just Placed on the Market—Designed to Match Victrolas VIII and IX.

The Long Cabinet Co., Hanover, Pa., has just announced a new style of cabinet for 1914-15 which is designed to harmonize with the Victrolas VIII and IX. The lines of the new cabinet are most graceful and it is highly finished, in keeping with the finish of the machine cabinets. The new cabinet, known as D70, may be had in mahogany, fumed oak, golden oak and weathered oak as desired.

In order that its dealers may take full advantage of the numerous endorsements it has received on behalf of its dance product, the Columbia Co. sent to the trade this week an imposing window poster featuring the text of these endorsements from prominent dancing enthusiasts in all parts of the country. Among the letters presented were those from Pavlowa, G. Hepburn Wilson, Vernon Castle, Joan Sawyer and others prominent in the terpsichorean art.

VICTOR EDUCATIONAL MATTER.

Interesting Literature on the Subject of Victors for the Schools Just Sent to Dealers—Some Convincing Figures by Mrs. Clark.

The Victor Talking Machine Co. sent out to its trade on Saturday a very interesting batch of literature devoted to educational matters that should not fail to prove of value at this time of the year, when the school season is going to commence. Accompanying this literature was an informative letter signed by Mrs. Frances E. Clark, the popular director of the Victor educational department, who pointed out the salient points of the literature sent to the dealers.

Probably the most significant phase of this publicity was the listing of 1,783 separate cities throughout the country that have placed from one to nearly 200 Victors in their schools. Every State in the Union, with the exception of Nevada, is included in this imposing list, and towns and hamlets that never found their way to the most detailed United States map own as part of their school equipment a Victor and a goodly library of records.

Mrs. Clark in her letter points out that more than 600 colleges, normal schools and universities are making the Victor a part of their work, many including it in their regular courses of study. It is also stated that Victors and Victor records have been used in over 100 large summer schools this season, and during the school year 1,300 demonstrations have been given in schools and Victor exhibits held at fifty State and national conventions by representatives from the Victor Co.'s educational department. Victor folk dance records have been used in 500 junior Chautauquas the past summer. This letter concludes with the suggestion that the dealers feature an educational window display during the next few weeks, and an illustration of a suitable one is presented, together with a list of the material necessary for its construction.

GETTING UP A SWAP.

"I can't afford to buy the lot."

"But you can have it for a song."

"If you really mean that we might dicker, I'll swap you a collection of phonograph records for it."—Courier Journal.

Pathésscopes

For The Schools



The illustration shows the first *Motion Picture Machine* designed and built particularly for School use. It consists of the "Popular" model *Pathéscope* for use with either direct or alternating current, or dry cells or storage battery, mounted upon a special *Institutional Stand* provided with rubber tired wheels and fitted with handles for the easy carriage up and down stairs in school buildings where no elevators are provided.

A hinged elevating baseboard is provided, with screw adjustment for centering the picture upon a screen at any height. The outfit, with 6' screen, lists at \$200 complete. Our new school circular "*Education by Visualization*" describes the instrument in detail, its uses in the school, and contains a list of suitable Educational Films for use with the *Pathéscope*.

Dealers will find this Instrument a quick seller to Schools, Churches and other Institutions.

For Demonstration or Catalogue, Address

Pathéscope

Dept. 6, Aeolian Hall, New York

AGENCIES:—515 Crozer Bldg., Philadelphia. 1101 F St., Washington. 507 American Bldg., Baltimore. 459 Washington St., Buffalo. 108 6th St., Pittsburgh. 622 Kittredge Bldg., Denver. 1516 3d Ave., Seattle. 25-29 Arch St., Boston. 635 Leader News Bldg., Cleveland. 147-151 Woodward Ave., Detroit. 800 Chestnut St., Reading, Pa.

RESPONSIBLE REPRESENTATION DESIRED ELSEWHERE

An exceptional opportunity for Talking Machine Dealers to add a PATHÉSCOPE DEPARTMENT and FILM EXCHANGE, or for Enterprising Men with some capital to establish a Permanent and Profitable Business of their own. Write for Agents' Circular.

A new Columbia

The Meteor

The announcement of this type has been delayed until we were prepared to furnish a low priced instrument of quality—one with all the ear-marks of Columbia value, and provided with exclusive Columbia equipment. The METEOR fulfills these requirements; it is a perfect musical instrument; reproduces the clear, full, natural Columbia tone.

It is equipped with

The exclusive Columbia tone-control leaves.

A powerful spring motor that may be wound while running, playing two records with one winding.

The Columbia bayonet joint tone-arm.

A Columbia full tone reproducer.

Ten-inch turn table.

A gradually tapering tone resonator running from reproducer to tone-control leaves.

The METEOR will attract to the Columbia line and to your store. It will in itself serve as a business getter, and create the record market you are looking for. And further—it will make for you satisfied customers and new friends.

A WORD TO THE WISE:—

Delay in ordering may result in delivery disappointments. Our supply will be limited up to January 1st.



Columbia Graph

Woolworth Eu

at a new price
or \$17.50 —



hone Company

New York



No Glue in the Binding of the UFFNER Patented Talking Machine Record Album

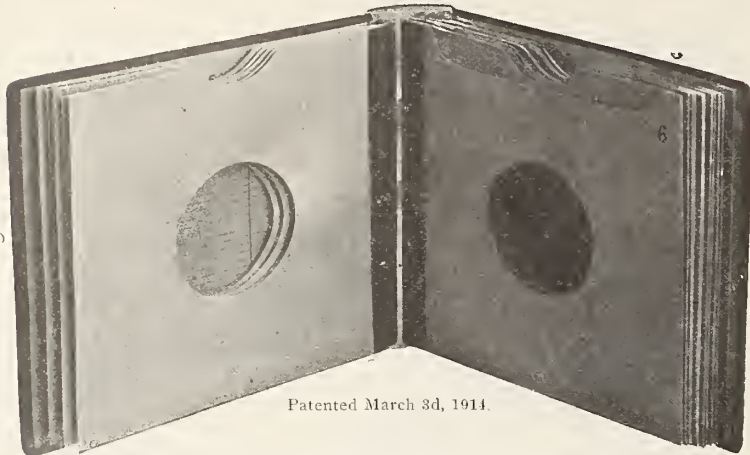

Patented March 3d, 1914.

EACH envelope is bound into a metal slot, the slot being stamped out of a piece of metal, nickel-plated, the entire metal part being riveted into a wooden back. The method of binding insures the greatest of strength, it being impossible to break the leaves from the back. The album opens flat without cracking.

The only improvement in album making since the TALKING MACHINE industry started.

Pockets are of high-grade green material linen bound, while the outside covers are of ART CLOTH. Leather covered pull to prevent scratching of polished surfaces. Made in three styles for VICTOR and COLUMBIA 10 and 12-inch records, including the new EDISON disc 10-inch records.

Also made for the new Victor Cabinets Nos. 10 and 11, holding 12 records.

Samples furnished on request.

UFFNER ALBUM CO.
75-77 Grand Street,
New York.

TO OPEN TWO PHONOGRAPH STORES.

Concrete Evidence of Activity Prevails in the Twin Cities—Fall Outlook Is Excellent and the Spirit of Optimism Prevails Throughout Talking Machine Trade.

(Special to The Talking Machine World.)

MINNEAPOLIS and ST. PAUL, MINN., September 10.—Two new talking machine stores will be opened in the Twin Cities about October 1 on a scale never before attempted in the Northwest, according to the promoters, the Minnesota Phonograph Co. The St. Paul store will be located in the old Raudenbush building at St. Peter and Sixth streets, which will be the retail center of the capitol city within a year or two, in the opinion of the real estate experts. This store will be under the management of William A. Lucker, whose present place of business is at 58 East Seventh street. This concern will be retained for a time and, for that matter, may never be abandoned. Victor and Edison goods will be handled.

The Minneapolis store will occupy the old quarters of the New York Central lines at 612 Nicollet avenue. It will be designed throughout by Purcell & Elmsley, famous architects, as an exclusively Edison shop. Lawrence H. Lucker will be the presiding genius. It has been suspected that there is a close business connection between both concerns, but if such is the case neither of the Mr. Luckers will admit it.

Victor goods are in great demand in spite of the war and all other depressing influences. W. J. Dyer & Bro., jobbers for the Northwest, are unable to meet their orders as promptly as they like,

and the Twin City retail houses, of which there are ten or twelve, find the volume of business growing upon them every month.

"Our Victrola department is a winner in every way," said R. O. Foster, of Foster & Waldo. "We are more than ever pleased with our experiment in establishing a talking machine department, as it never has failed to bring in a goodly revenue and to grow with each succeeding month."

Archie Matheis, head of the Talking Machine Co., has designed a Victrola window which is attracting attention. The theme of his design is "The New Features of the 1915 Victors." All the improved parts are shown separately, and from each is a colored silk ribbon leading to a card on the window bearing the name of the part. That the company is doing a nice business may be known by the fact that the total sales by August 13 had equaled the entire month of August, 1913.

Trade is working out Nicollet avenue, and while the Talking Machine Store three years ago was considered then to be a little far out, it is now in the best stretch of the Nicollet avenue retail section.

Columbia goods are selling well in the Minneapolis and St. Paul stores, and likewise in the country orders are going in for the Christmas stocks, which will be larger than ever. The August business, in spite of various drawbacks that have affected the general retail world, may have been reduced in volume of sales in the Columbia stores by these causes, but the books show a large increase over the totals for August, 1913, and it causes the local managers to wonder what they might have done had it not been for the war.

REMOVE TO ITS NEW QUARTERS.

(Special to The Talking Machine World.)

BOSTON, MASS., September 9.—The Arion Manufacturing Co., manufacturers of the Arionola, a popular-priced phonograph, has removed from 9 Doane street to its new quarters at 250 Devonshire street, this city. Some little confusion has oc-



curred, due to the association of the Imperial Phonograph Co. with the Arion Manufacturing Co., whereas both are entirely separate and distinct.

Chas. F. Sims is the general sales manager of the Arion Manufacturing Co. The accompanying illustration shows the trade-mark of the Arionola, which is placed upon all machines.

"Lives of 'lame ducks' all remind us,
That there surely comes a time
When the man who's slow, and slower,
Can't 'cough up' a single dime."

J. S. Cooper, Jr., has opened the first music store in Independence, Ore., where he will handle pianos, player-pianos, sheet music and Columbia graphophones.

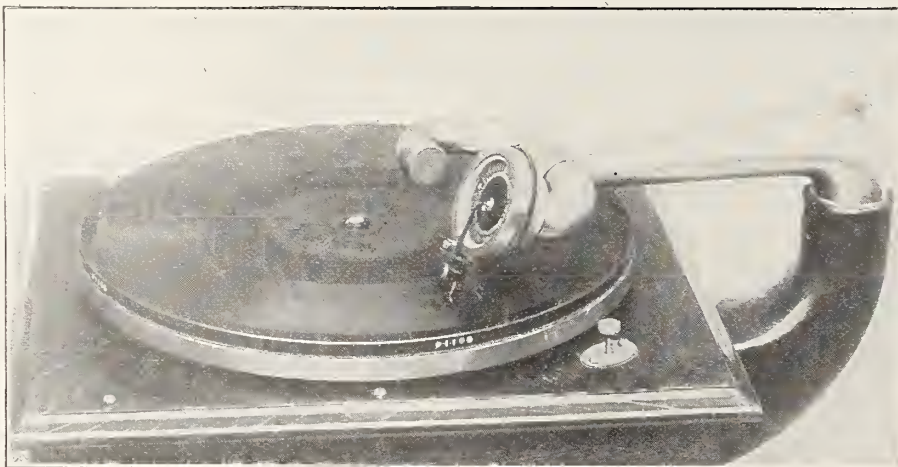

**DO YOU WISH
TO PLAY
EDISON DISCS?**

Price \$2.00

LEXTON SPECIALTY CO., 216 West 99th St., N. Y.

BIG COLUMBIA-AEOLIAN DEAL JUST CONCLUDED.

Aeolian to Take Columbia Line—Long Term Contract Signed—Complete Line of Columbia Grafonolas and Records to Be Carried at Aeolian Hall and in All Aeolian Branches.

The Aeolian Co. has contracted to take on a complete stock of Columbia Grafonolas and Columbia records—straight through the line. The importance of this announcement becomes apparent in view of the well known fact that the Aeolian Co. has heretofore operated under an exclusive Victor jobbing contract.

Several months ago the Aeolian Co. decided to investigate the demand for Columbia products that was reported by its several branches and also to make a thorough examination into the quality and value of such goods, subjecting both machines and records to severe tests. The result is the contract which has just been completed between the Aeolian Co. and the Columbia Graphophone Co.

George W. Lyle, general manager of the Columbia Graphophone Co., when seen at his offices in the Woolworth building confirmed the trade report that the Aeolian Co. has decided to install a complete line of Columbia products in its New

York store and all of its branches. Mr. Lyle stated to The World: "The order for Columbia products placed with this Aeolian contract is one of the largest initial orders ever placed and it is pleasing enough to the Columbia Co. as an order for merchandise, but it is even more pleasing as carrying a very distinct and unmistakable significance of the change in the talking machine industry, which has been so noticeable during the past two or three years, namely, a desire on the part of the dealer to handle any line of merchandise that is in demand and has quality behind it. A change for the better in every way—for the customer whose convenience is best served, for every dealer in the business and for the industry as a whole."

He said he would have other important announcements to make in the near future concerning this movement whereby the talking machine business is rapidly reaching a merchandising basis.

THE CUSTOMER AS AN ASSET.

He Is a Valuable One to the Talking Machine Dealer When He Is Satisfied, When He Feels That He Is Being Treated Right—It Pays to Cater to Fussy, Particular People—It Is a Good Investment and Pays Good Dividends.

In the hurry to attend to many customers it is sometimes a little annoying to a dealer to meet one who is exceedingly particular about details. He is apt to style such a one "fussy" or "cranky." Yet that very customer, fully satisfied, may, and probably will, prove a more valuable asset than one who is not disposed to be particular. The shrewd business man is he who can handle each customer, whatever his or her peculiarities, with the utmost ease, deliberation and respect. A little study of human nature will show that the "fussy" individual is usually the most talkative one when fully satisfied, and that talk is more than likely to be in praise of the house that gave her most careful consideration.

One very prosperous business man in New York instructed all his clerks to call him whenever they got a hold of a "fussy" individual. No matter how busy he was, he kept himself open to wait on the "particular" customer, and so skilfully did he handle them and eventually turn them, one by one, over to "Mr. Smith" or some other patient salesman (who realized the difficult yet responsible task of being very considerate), that his house grew to large proportions because of the entire satisfaction everyone received who dealt with it.

One of the great steamship lines plying between New York and Liverpool has issued a series of printed instructions to all its employes aboard ship, and the dominant note is summed up in these significant words:

"The patrons of this line pay your salary and mine; there could be no ——— steamship line without patrons; therefore, it behooves every employe from the lowest to the highest, to treat every patron with the utmost respect and attention and never enter into any dispute; if a difference arises immediately seek a superior officer and introduce the patron to him and let no word or look show anything but courtesy and respect."

In the phonograph line it is equally true that a satisfied patron is a valuable asset, says the Edison Phonograph Monthly. It pays to satisfy every customer; if you have sold an Edison machine follow it up and see that it is giving satisfaction; if you get a hurry-up request by telephone or otherwise, be sure to follow it up yourself later in the day and see that it has been filled. If the party has a telephone, call her (or him) on 'phone and see that satisfactory service has been given. If certain records are wanted on a particular day or hour follow them up and see that there is no slip-up in the service. Particular requests should never be lost sight of till satisfaction is guaranteed and carried out to the letter.

Sometimes it seems as if these little matters were not worth the care and attention of those who

occupy responsible positions in a house, particularly when the busy season is on. But that's a mistake; they are highly important, a personal touch, a personal message from someone responsible in the house makes a customer satisfied. It creates a confidence in the house that nothing else can do.

Another feature that a satisfied customer appreciates is to have some forethought given his or her needs. If you know of some reason why a certain record will be acceptable on a specified occasion, let your forethought be brought to the patron's attention and ask if it may not be included in the order or sent by special order.

There are a hundred and one ways of studying how to make satisfied customers, and it is just as profitable as to study how to keep a good balance in the bank.

ENJOY LABOR DAY PICNIC.

Employees of Stewart Talking Machine Co., Indianapolis, Spend Lively Day at Outing.

(Special to The Talking Machine World.)

INDIANAPOLIS, IND., September 12.—Fifty-three employes of the Stewart Talking Machine Co., distributors in Indiana for the Victor Talking Machine Co., attended the annual Labor Day picnic given by the Stewart Company in a grove along one of the Hoosier capital's wooded streams. The party started out from the Stewart headquarters, 221 North Pennsylvania street, early Monday morning in automobiles. George E. Stewart acted as master of ceremonies, and arranged the entertainment for the employes. Chickens were cooked over open fires. One of the features of the day was the ball game between the married men and the single men. W. M. English, traveling representative of the Stewart Company, scored the first run. The single men whipped the benedicts to the tune of 24 to 16. Flowers and candy for the women and girls were supplied at the store. W. S. Barringer, manager, reports that everybody "had the time of his or her life."

TALKING MACHINES IN FAVOR.

In an article on the trade and industries of Syria, published in the September 7 issue of Daily Consular and Trade Reports, Consul-General W. Stanley Hollis, stationed at Beirut, Asiatic Turkey, gives a series of interesting figures relative to the imports and exports at this port during 1911 and 1912. These figures show that during 1911 talking machines to the value of \$2,650 were imported at Beirut, while in 1912 this total was practically doubled, the value of these imports reaching the sum of \$5,140.

Time may be money, but it hangs much more heavily on our hands.

SAVES
time, space and money.

VISIBLE
Dustproof, Warp-proof.

FILING
Finding and Reordering in one-fourth usual time.

SECTIONAL
Fits any size business. Floor space 40½" long. Stores 1,200 records. All in easy reach.

SIGNALS
(Numerical.) Locates every record. Color Signals locate all similar records.

SALES
Record Envelope is a "Watch Dog" for your investment.



The "OGDEN"

pays for itself in three months. You should know the selling value of every record. Cut out the Dead ones and be able to get any record in 4 seconds.

SALES SYSTEM BULLETIN FREE

upon request with name of your Distributor. Write for descriptive booklet and list of Jobbers.

The "OGDEN" SECTIONAL FILING CABINET AND SALES SYSTEM

is Guaranteed. Manufactured by

J. B. OGDEN - - Lynchburg, Va.



Fast sellers every week in the year: The Columbia "Eclipse"—\$25; the Columbia "Jewel"—\$35; (the only fully cabinetted instrument at the price); the Columbia "Favorite"—\$50 (the biggest seller of any make at any price in the market for the last four years).



(Write for "Music Money," a book "full of meat" for those dealers interested in quick and frequent turnover of capital.)

**Columbia Graphophone Company
Woolworth Building, New York**

HOW JOBBER CAN AID DEALERS.

Advertising Suggestions and Sales Helps Assist Greatly in Arousing the Enthusiasm of the Retailer, Says Daryl H. Kent, Secretary of Kent Piano Co., Well-Known Edison Jobber of Vancouver.

We have been asked to express our views on the above phase of the business.

At the outset we would have it understood what we say will apply mostly to the small dealers in sparsely settled parts of the country, where communication is not of the best, and where distances are somewhat of a drawback.

In British Columbia, for instance, owing to its vast area, the population is very much scattered, the great majority of the entire population of the Province living in the few large cities.

The small dealer, therefore, is somewhat handicapped by reason of distance from the larger centers, poor means of transportation, and in many cases by reason of lack of enthusiasm in the goods that he may be unsystematically handling.

To work up such enthusiasm one of the best means is to send a representative to visit the people at stated times, but this is not always, in a country such as British Columbia, a paying investment for the jobber, as the time and money expended do not reap anything like a reasonable return.

In certain sections we think it a good plan to ascertain what the dealer is doing to advertise the Edison goods, and to offer suggestions to him the jobber will write a series of ads based on his knowledge and experience in such matter, with the request that he have them inserted in the local or close locality papers, writes Daryl H. Kent, secretary of the Kent Piano Co., Ltd., Vancouver, B. C., in the Edison Phonograph Monthly. A dealer, who in a great majority of cases in this Province handles all sorts of commodities, very often does very little advertising, and if he does it is in a general way, so he has to be enlightened on the good results to be obtained by specific ads. This is where

the jobber can be of use and mutually helpful, providing, of course, he has the co-operation of the dealer.

Another dealer's help is to circularize him from time to time with other than the regular notices and literature sent him from the Edison Co., as we are of the opinion that a great deal of this "from Edison to dealer" printed matter goes to waste, and we are wondering whether if this same matter, mailed by the jobbers in their own envelopes, and in some cases on their own stationery, would not accomplish more good. However, the jobber can circularize the dealer, often recommending certain machines or records just to hand, and touching on other points that from time to time turn up, with good results, mutually beneficial.

The jobber can, where possible, secure mailing lists from the small dealers, and scatter literature among them, by mail direct, at the same time mentioning the dealer in the locality where the goods can be had, and thus be the means of securing added business for both himself and the local dealer.

The jobber might also take it upon himself to educate the smaller dealers into the value of canvassing, but this means up-hill work for some time, as in most of the small towns one man and a boy run a general store, and to make this one man realize the advantages of extra help, while he or his extra help could get out and sell phonographs, is somewhat of a large undertaking.

MULTI-PLAYING NEEDLE

Introduced by the Sonora Phonograph Co. of New York—Some of Its Salient Points.

The Sonora Phonograph Corporation, 57 Reade street, New York, announces the Sonora Multi-playing needle, which is a jewel needle playing lateral-cut records without changing the needle. Furthermore, it is guaranteed for three months. Geo. E. Brighton, president, in commenting on the Sonora multi-playing needles, said: "It has



The Multi-Playing Needle.

been five years since the Sonora Company introduced the first perpetual jewel disc record needle and during which time we have been working to perfect it. We recently succeeded in doing this and the Sonora multi-playing needle is the result. The only trouble we have had so far is filling orders for the demand is so large. A number of our retail customers at our retail store, for instance, buy five at a time, so the possibilities of big sales with the retail merchants of the country, rest only with the dealers themselves."

HAS CAPITAL STOCK OF \$1,000,000.

The Pure-O-Phone Co. has been incorporated under the laws of Delaware with a capital of \$1,000,000 for the purpose of manufacturing and dealing in talking machines and records. The incorporators are: W. G. Taylor, Clarence J. Jacobs and Chas. B. Bishop.

GOT A NEW "HUNCH."

Old-Time Inventor of Motorless Talker, Now in Insane Asylum, Tells of His Latest Invention.

A gentleman was visiting an insane asylum. He met a man in the hall.

"Who are you?" asked the visitor.

"Me?" said the man. "Why, I'm an old-time talking machine man who invented a motorless talker." It was a big thing but the powers that be were jealous of my success—but I ain't crazy. Not on your life. All the rest of them are crazy, but not me. I've got a new invention that outdoes the talker, one that will make me so rich that John D. Rockefeller will look a poor man beside me."

"What is it?"

"A patent fly-catcher. Greatest thing in the world. Here, I'll show you how it works."

The man took a sheet of paper and drew a bird-cage. "That," he said, "is a parrot's cage—just a common cage—but you observe that on this side there is a door with a heavy iron knob, and that there is another door on the other side, also with a heavy iron knob.

"Now you see, you take this parrot's cage and put it on a pedestal fourteen feet high, the pedestal standing on a marble slab. Then I place a ladder on this side, reaching up to one door, and a ladder on the other side, leading to the other door.

"This is how it works. The unsuspecting fly comes along and climbs up the ladder on this side. It opens the door by means of the iron knob, walks through the cage and opens the door on the other side. Then it starts down the other ladder.

"That's where we catch him!" the inventor continued, excitedly. "That's where the invention is. That's where I shall get my money. You see, the fourth rung is missing in this second ladder, but the fly doesn't know it, and falls on the slab and breaks his neck."

The gentleman goat gets there. Yet he often is guilty of overdoing the butting act.

The fellow who depends entirely on luck isn't to be depended upon.

Victor Manager Wishes to Change

Several years' experience in New York City and vicinity, but now managing large retail department in Middle West. Is familiar with department store detail, and has proven ability. Address Box No. 1,000, The Talking Machine World, 373 Fourth Ave., New York.

PARTNER WANTED

With one to five thousand dollars, to develop profitable and growing talking machine business. Present stock \$5,000 all clean. Fine store and location. Victor and Columbia agencies. Address H. C. Williams, 6312 Ashland Ave., Chicago, Ill.

"DUSTOFF"

RECORD CLEANERS

In selling your customer a "DUST-OFF" you render a distinct service your customer will remember you by. "DUSTOFFS" represent the best the market affords in high grade selected material which ensures their remarkable merit—getting into the minute sound grooves and removing the dust and dirt without scratching.

FOR ALL MAKES OF RECORDS
Adds life to records—and adds more profits to your business. Two models:

50c. de Luxe Model
15c. Regular Model.

Most jobbers can supply you, or write us direct.

(Also available for use with your own advertisement. Write for details.)

SAMPLES approval if you write giving jobber's name.

MINUTE SHINE CO.
285 Canal Street, Providence, R. I.



THAT THE DEALERS ARE INTERESTED

In the Pathéscope Is Evident from the Letter Reproduced Below—Is Proving a Valuable Side Line for Talking Machine Houses.

The general attention being bestowed on the Pathéscope, the recently introduced home moving picture machine, is well illustrated in a rather

7/21/1914.

The Pathéscope Exchange,

Philadelphia,

Pa.

Kind Gentleman:

Having Noticed A Great Deal Of Writing And Excitement Concerning The Pathéscope Machine As Advertised In The Talking Machine World. Until I am Somewhat Interested In It. I Would Greatly Appreciate You Making Me A Clear Explanation Of This Machine And Its Films What Length Films Do They Use In This Machine And What Makes The Picture? As I Believe The Manufacturer States That There Is No Electric Current Used In Its Operation .. Also Give Me The Correct Address Of The Manufacturer Whom I Put This Machine Up. And Where Should I Apply For Application As To Become A Dealer In My Territory? Please Send Me One Of The Catalogs Of This Machine Explaining

It Thoroughly From Beginning To Its End Also Showing Photographs Etc. What Do These Machines Retail At? How Do The Manufacturer Protect Its Dealers? Do They Also Allow Them To Sell On The Monthly Payment Plan? As From All Ideas I Can Secure From It As Explained In The Talking Machine World I Believe This Is A Wonder Come Here To Stay With No End To Sales Through The Dealers.

Hoping You Will Please Give My Letter Your Careful Attention. Also Looking Forward For Your Catalogs And Literature Etc.,
Yours Respt.

unique letter of inquiry which the Philadelphia headquarters of the Pathéscope recently received from an interested talking machine dealer. Incidentally, this letter, reproduced above, is conclusive evidence of the result-producing powers of talking machine World advertising.

TO HANDLE EDISON DISC LINE.

The Pianostyle Music Co., 238 Livingston street, Brooklyn, N. Y., which recently started in business in the retail selling of music rolls, has added Edison disc phonographs to its line. Frederick Harlan is vice-president, while A. R. Leary is treasurer. Both men have had considerable experience in the various lines which they are now specializing in, and this bids well for the success of the house.

INCORPORATED IN IOWA.

The Chase & West Talking Machine Co., of Des Moines, Ia., with capital stock of \$125,000, has just been incorporated by Charles R. Chase and Lewis J. Syle.

Many a man lives by his wits who never wrote a joke in his life.

Back Copies of the World for 1906 and 1907 Desired.

If any subscribers have copies of The Talking Machine World for 1906 and 1907 kindly communicate, stating price for same. "Historical," care of The Talking Machine World, 373 Fourth Ave., New York.

TRADE NEWS FROM LOS ANGELES.

Talking Machine Takes Place of Speaker at Political Meeting—Happenings of Month.

(Special to The Talking Machine World.)

LOS ANGELES, CAL., September 7.—A novel demonstration of the possibilities of the talking machine was given in this city recently when, prior to the primary election of State and county officers, a candidates' day was given at the beautiful Hooker Gardens on West Adams street.

Candidates from all over the State attended and each was expected to make a brief talk from the platform. When the turn of the Hon. Joseph Knowland, candidate for United States Senator, came he was not present, but as the rules of the "day" called for a speech by him his place was taken by an Edison Home phonograph loaned by the Southern California Music Co. Two records made in Oakland by Mr. Knowland were sent here and thus the people were enabled to hear him even if they could not see him. The records were very clear and received a "big hand."

Francis Raymond, a special representative of the Thos. A. Edison Co. for the Pacific Coast, is in the city at the present time. He reports a brisk business in the Edison disc phonographs and records.

Chas. S. Ruggles, of Sherman & Clay, wholesale, reports several heavy shipments of records and machines from the Victor factory. He says he is catching up on his back orders and expects to be able to take care of all future ones.

Irving Andrews, of the Andrews Music Co., says his sales for August were more than three times as much as the corresponding month in 1912.

Frank Morino, formerly with the Southern California Music Co., is now with Barker Bros. J. W. Booth, in charge for Barker Bros., is very much pleased with their last month's business. He says every month this year is better than the preceding one. George S. Barnes is back from vacation.

L. E. Newton, formerly with the Southern California Music Co., of this city, has left for San Diego to take charge of the talking machine department of its branch store in that city. E. S. Dible, who has had charge of the San Diego store (talking machine department) for the last four years, is now on the sales force with the same company.

A. Graham Cook, manager of the talking machine department at the Geo. J. Biskel Music Co., is now on vacation.

The Columbia Graphophone Co., wholesale, says it has been unable to supply the demand for "Cohen at the Telephone" (A1516).

INTRODUCE NEW SPECIALTY.

The Standard Gramophone Appliance Introduce a New Record Cleaner—Manager Kirkman Is Optimistic.

The Standard Gramophone Appliance Co., 173 Lafayette street, New York, manufacturer of a number of very successful talking machine accessories, has just placed on the market a new record cleaner, to be known as the "Simplex" record cleaner, and which will retail at 15 cents. This new cleaner is made of highly polished wood and is very attractive. It is of a smaller cleaning area than the popular "Standard" record cleaner manufactured by this company, but those dealers who have seen it predict that it will meet with a ready sale throughout the country.

In a chat with The World, Thomas W. Kirkman, manager of the company, stated that the fall outlook was decidedly encouraging. "We are convinced that the coming season will be a prosperous one from every standpoint," remarked Mr. Kirkman. "Our fall advance orders are of a substantial nature, and the fact that the dealers have not overstocked the past year will mean a steady consistent placing of orders.

"Our 'Standard' record cleaner is continuing to increase its sale day by day, while our needle cutter and automatic stop have firmly entrenched themselves in the minds of the dealers as articles in which they may place complete confidence. The satisfaction that our products is rendering is well illustrated by the numerous repeat orders we are receiving from well-pleased members of the trade."

At Your Service

Landay BROS INC.

VICTOR DISTRIBUTORS EXCLUSIVELY

Connect Yourself

with the Progressive House who will be glad to advise you how to obtain more retail business.

OUR POLICY

"No account accepted unless perfect service can be assured."

Automobile service in New York City will insure our dealers prompt delivery.

Motor suburban service will insure out-of-town dealers earlier deliveries.

VICTOR Contracts are now ready for mailing to those dealers who wish to take advantage of our perfect service for the coming season.

Our representative will gladly call upon request.

**WHAT YOU WANT
WHEN YOU WANT IT
ALWAYS IN STOCK**

Landay BROS INC.

563 FIFTH AVE.

NEW YORK



This is a harvest time for foreign record business! The Columbia recordings of patriotic music of all nations—vocal, as well as selections played by full military band in martial time—offer possibilities that no talking machine dealer can well ignore.



Write for full particulars to

Foreign Record Dept., Columbia Graphophone Co., Woolworth Bldg., N. Y.

PROMINENT IN RICHMOND, VA.

John G. Corley, Head of the Corley Co., Among the Leaders in Business and Musical Affairs of Virginia's Progressive Capital.

(Special to The Talking Machine World.)

RICHMOND, VA., September 7.—The importance of John G. Corley, head of the Corley Co., the prominent talking machine and piano house, of



JOHN G. CORLEY

Richmond musical. A great many people agree with him, and add that he has done even more for the welfare and prosperity of Richmond.

In private life Mr. Corley is president of the Corley Co., one of the greatest music houses in the South. He is an active member of the board of directors of the Chamber of Commerce and heads the important committee on conventions. For years he has labored on the city school board, retiring recently in order to enjoy a surcease of work. He was once president of the Richmond Rotary Club and played no small part in making that organization something besides a social medium.

Perhaps the greatest work which Mr. Corley has done for Richmond, however, has been accomplished since he undertook the guidance of the Wednesday Club. In the years that he has been president of this ancient musical society, Mr. Corley has led the organization out of the narrow field of a singing society and made it the vehicle for the

musical education of Richmond. If the board upholds his aims he will some day give Richmond grand opera. The National Piano Dealers' Association at its recent convention in New York elected Mr. Corley vice-president, placing him in line to become head of this influential organization. In fact, organizations have a great way of placing him in line to direct, presumably for the reason that John G. Corley has proven himself to be one of the most earnest, serious and efficient directors you will meet in a day's journey.

The article reads: John G. Corley admits that he is the man that made

musical education of Richmond. If the board upholds his aims he will some day give Richmond grand opera.

The National Piano Dealers' Association at its recent convention in New York elected Mr. Corley vice-president, placing him in line to become head of this influential organization. In fact, organizations have a great way of placing him in line to direct, presumably for the reason that John G. Corley has proven himself to be one of the most earnest, serious and efficient directors you will meet in a day's journey.

NOW THE TRANSOPHONE.

Latest Attachment for Edison Dictating Machines to Simplify Means for Causing Record to Repeat When Desired—How It Operates.

The dictating machine department of Thomas A. Edison, Inc., has announced as ready for the market the new Transophone, which is designed as a decided aid to the typist by simplifying the means for "back-spacing" the record and causing it to repeat the dictation it contains. The new device consists of a typewriter key of the usual form attached to the typewriting machine and connected electrically with the contrivance on the dictating machine for shifting the reproducing arm backward. The button is of the "quick-make-and-break" type and operates as readily as the usual typewriter key.

In order to disconnect the electric button on the typewriter from the dictating machine, a detachable connection in the cord may be broken at will. This enables the operator to close a folding typewriter desk without difficulty or loss of time.

The arm of the Transophone is back-spaced with a magnet, energized by the button on the typewriter. This had to be developed carefully for noiseless operation, and for easy attachment on every old model Edison dictating machine, which is a fixed Edison engineering policy.

The Transophone will, by allowing the attention of the typist to be centered in the typewriter at all times, make for both speed and accuracy.

Lots of people are sure they are right who never go ahead.

NEW UDELL CATALOG READY.

Will Show Complete Assortment of Cabinets for Player Rolls, Sheet Music and Talking Machine Records—Prepared for Dealers.

In a week the Udell Works, of Indianapolis, Ind., manufacturers of Udell cabinets, are planning to mail their new catalog of cabinets. It will represent the most comprehensive showing of cabinets for piano player rolls, sheet music and disc records that they have ever brought out. It



A Popular Udell Cabinet Style.

will also include a line of piano and player benches.

Commenting on the importance of this volume, H. T. Griffith, sales manager, said: "This catalog will be 9 x 12 inches, and is arranged absolutely for the benefit of the dealers. One new feature of the line that is worthy of comment is that every cabinet from the cheapest up is being made of sufficient depth to care for music rolls."

Business here is reported to be in good shape and the inflow of orders is sufficient to indicate that the fall will be of good volume.

BEST TO START RIGHT.

The official head of a large business concern noticed one of his youngest employes sticking postage stamps on letters—slapping them on in any way, straight, sideways, or upside down. "My boy," he said, pleasantly, "why not put them on straight, with the right side up."

"I don't see as it makes any difference," the youth responded. "They'll go just the same."

"Perhaps they will," responded the employer. "But I was not thinking so much about the letters as of you. The habits you form now will stick to you through life—learn to do things in the right way, and you will avoid many a temptation to do them in some other way. Hereafter put each stamp on in the right way, and keep that idea in your mind in all you do. That's the only sure way of getting ahead in this concern."

The Arionola

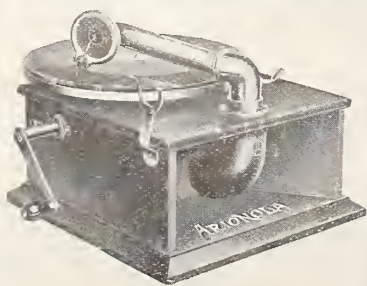

A Proven Ready Seller for Dealers

New principles of phonograph construction giving the highest quality of phonographic reproduction. Plays any disc record. Light and compact. All workmanship of the highest standard.

Retail Price \$12.00

Be the first to seize this opportunity in your city. Write for dealer's prices, and further information to

Sales Department

ARION MANUFACTURING COMPANY
250 Devonshire St., BOSTON, MASS.



GERMANY



GREAT BRITAIN



AUSTRIA



PORTUGAL



SERVIA



SWITZERLAND



SWEDEN



ITALY

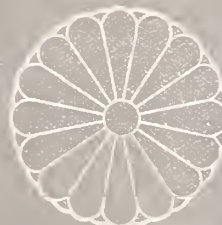

JAPAN



BELGIUM



FRANCE



NETHERLANDS



DENMARK



TURKEY



NORWAY



GREECE



SPAIN



RUSSIA

A line of Foreign Records, representative of every country in Europe is today strengthening every Columbia dealer in handling the present phenomenal demand for European national music.

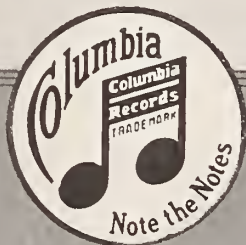

LATEST REPRODUCING DEVICE.

New Attachment, Marketed by the Lexton Specialty Co., New York, Provides for Playing of Vertical or Lateral Cut Records on One Machine Without Change of Sound-Box—Includes Special Sapphire Needle.

One of the latest devices for permitting of the playing of records with a vertical cut on machines, designed for the use of records with a lateral cut, is the invention of M. V. Roof and A. G. Ostermoor, and is being marketed by the Lexton Specialty Co., 216 West Ninety-ninth street, New York. The device, which is illustrated in the advertisement of the Lexton Co. on another page of The World this month, consists of a special joint to be attached to the tone-arm of the Victor machine, where it joins the gooseneck, and provided with screw threads by which the ordinary tone-arm may be attached in a position at right angles to the record groove. A cap covers the end of the gooseneck while the Edison type of record is being played and the cap may be, in turn, attached to the special connection while the Victor type of record is being used.

The device also provides for the use of a special sapphire needle that may be used on both Edison and Victor types of records, and another sapphire needle of special design is also supplied for the playing of Pathé records. The attachment, complete, is listed at \$2 retail and jobbers and dealers, writing on their letter-heads, may obtain samples at \$1 each.

J. W. SWANSON NOT WORRIED.

Well-Known Talking Machine Man of Texas Sees Only Big Business for United States as Results of War Between European Nations.

(Special to The Talking Machine World.)

HOUSTON, TEX., September 7.—J. W. Swanson, head of the Houston Phonograph Co., of this city, who has just returned from a tour of inspection of the store controlled by his company in San Antonio, Fort Worth and Dallas, does not worry over the permanent effects of the European war on the business of this country. Mr. Swanson said, in an interview: "There is absolutely no cause for alarm on the part of the people of the United States over the war in Europe, and the thing to do is to take advantage of the opportunity and extend commerce into countries not affected." He reports excellent business in both the Edison and Victor lines.

A dealer's reputation is no better than his goods.

LATEST COLUMBIA AGENTS.

New Accounts Added During Week—Issue List of War Music—Pierce Co.'s Campaign.

The past week has been a busy one for the Columbia Graphophone Co. in near-by territory, a number of important new accounts being added to the company's extensive list of local representatives. These new agencies include Ludwig Baumann & Co., 49-51 Market street, Newark, N. J.; F. C. Kraemer, 8 Lincoln street, Jersey City, N. J.; L. W. Caldwell, Troy, N. Y.; J. Solow, 1116 Avenue J, Brooklyn, N. Y.; Daniel Cantor, 917 Freeman street, New York, N. Y. Several of these new accounts are active piano dealers who thoroughly understand the most successful methods of introducing the Columbia product to their patrons.

The advertising department of the Columbia Co. issued this week a very timely and appropriate window-poster in the nature of a list of patriotic music of the nations now at war in Europe. The flag of each nation with its national anthem and the number of the record are featured prominently on a strip which may be detached from the entire list if the dealer does not handle that particular language in his foreign record department.

The Pierce Music House, of Eureka, Cal., is carrying on a successful newspaper campaign on behalf of Columbia products which is achieving fine results.

ISSUE ATTRACTIVE BOOKLET.

New York Album & Card Co. Prepares Handy Catalog of Its Line of Disc Record and Photo Albums—Numerous Styles Featured.

The New York Album & Card Co., 23 Lispenard street, New York, manufacturers of disc record and photo albums, has just issued an attractive booklet featuring its extensive line in handy form for use by the company's dealers. This catalog lists the numerous styles of albums it manufactures, together with adequate information as to their distinctive merits and their prices.

This company, which has achieved a gratifying success in the talking machine field with its record albums, has for many years been catering to the dealers throughout the country with a comprehensive line of photo albums which have been giving perfect satisfaction. These albums are furnished in several styles, permanently bound, flexible and loose leaf, and are constructed in a high-grade manner that makes for their durability and popularity with the dealers and their patrons.

**Some Good News to All Talking Machine Jobbers**

We have succeeded in inventing a Record Album which has leaves bound in nicked metal. Which absolutely insures durability.

It is the greatest album invention ever made, and it will give you many talking points over the ordinary album.

Lack of space prevents a full description, so send for the whole story to-day and for sample and prices.

Patented and manufactured by the



Boston Book Company

66-68-70 Broadway
Brooklyn, N. Y.

1915 MODEL COLUMBIA "LEADER."

The Columbia Graphophone Co. has just placed on the market a new addition to its machine line, designated as the 1915 "Leader, Equipped with the Columbia Individual Ejector," which will retail at \$85. This 1915 model is the same as the popular

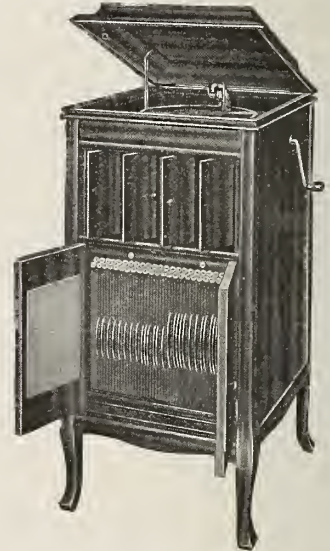

New Columbia Style.

"Leader" machine which has scored a pronounced success the past year, except that it presents a more attractive appearance by reason of a more artistic cabinet and is equipped with the Columbia individual ejector, which is a record filing interior. This provides for a separate compartment for each record, keeping the record clean at all times and thereby prolonging its usefulness. Each compartment has an automatic cleaning device or brush which cleans the record when it is taken out and again when it goes back to the compartment.

The Columbia Co. is equipping all its upright cabinet machines with this individual record ejector as rapidly as possible, and the next machine to be placed on the market containing it will be the "Mignonette," the \$100 model, which will retail at \$110 with this new filing device.

THE ELECTRO-PHONOGRAPH CO.

The Electro-Phonograph Co. filed a certificate of incorporation this week with the Secretary of State at Albany, N. Y., to engage in the manufacture of an attachment for cranking or winding graphophones. The capital is given as \$200,000 and the incorporators are B. B. and C. R. Johnson and F. Meyers, New York.

Among the latest addition to the ranks of the talking machines manufactured in this country is the Premier, a low priced machine made in Harrisburg.

Make a Double Profit on Talking Machines

Udell cabinets are made to fit the following disc talking machines:

Edison.
Victor.
Columbia.

The manner of filing discs is by upright partitions.

Back of each Udell cabinet is the Udell guarantee. It means satisfied customers. Write for "New Book," No. 47, now.

AFTER you've sold a customer a talking machine and records, he's almost sure to want a cabinet, especially if he sees the Udell cabinet.

Show it to him. Have Udell cabinets on your floor and make this extra sale.

From a "long" line of cabinets we have selected eight that dealers have found to be "best sellers." We have concentrated on these eight, and are now making them to fit any talking machine in style or finish. Wherever possible we even follow the "lines" of the machine, insuring a perfect match.

People will soon begin buying talking machines for Christmas. Prepare to sell a Udell cabinet with each machine, and make a double profit.

Our "New Book" No. 47 will help you. Write for it to-day.

The Udell Works, 1205 W. 28th Street, Indianapolis

H. E. PARKER LEAVES FOR THE WAR.

Advertising Man for Columbia Co. Off to Join British Army—Did Some Excellent Work.

Henry E. Parker, a member of the advertising department of the Columbia Graphophone Co., and one of the most popular men in the executive offices of the company in the Woolworth building, sailed Wednesday on the "Olympic," in order to place himself at the disposal of his home country—Great Britain—and join his county regiment.



H. E. Parker.

Although the English military authorities have not yet issued a call for the reservists in America to join their colors in England, Mr. Parker felt that it was a duty he owed to his country to serve it in time of war without waiting for an official call from home, and accordingly decided to sail this week.

Realizing the appalling magnitude of the war in Europe, Mr. Parker requested

a leave of absence from the Columbia Co. as soon as war was declared, with the understanding that he would leave for the front as soon as duty called him. A large number of his associates bid him Godspeed as the boat sailed September 2, hoping with all their hearts that he would return to America safely in a short time.

Henry E. Parker was responsible for a considerable amount of the excellent advertising copy turned out by the Columbia advertising department, and in addition edited the "Columbia Record," the company's official house organ, and was also in sole charge of the "Dictaphone Mouthpiece," a remarkably successful publication. Having traveled the world over, and gained a knowledge of places and things that was truly remarkable, Mr. Parker's personality was most pleasing and admirable. His signal ability had won for him continued success during his several years' connection with the Columbia Co., and The World joins with his many friends and acquaintances in wish-

ing him all good luck in the performance of his duty to his motherland.

Before sailing Mr. Parker was presented with a beautiful gold fountain pen from his associates in the Columbia Co.

IMPORTANT REPORT PRESENTED.

House of Representatives Gets Bill Ending Long Delay on Patents—Measure Reveals Section That Prohibits Dealer Fixing His Own Prices—Some Radical Features.

(Special to The Talking Machine World.)

WASHINGTON, D. C., August 11.—The report of the Committee on Patents on the Oldfield bill proposing a general revision of the patent laws was filed with the House to-day. The main purpose of the bill is to expedite the granting of patents to prevent the protection some applicants enjoy by the delay possible under the existing law.

The charge is made that patents have been delayed as long as fifteen years, "and that by delaying answers to simple letters for months at a time applicants for important patents have obtained the protection of 'patent pending' law," thereby blocking competitors. The bill provides that applicants for patents may have only two years in which to present their cases and there is a provision that patents shall be acted on without delay.

The bill repeals that section which makes it unlawful for a dealer to sell a patented article at a price less than that prescribed by the maker. In such cases suit will have to be brought in State courts for breach of contract.

A patent that has not been in use for a period of three years may be obtained from a manufacturer under license. This provision is intended to prevent "shelving" a patent, a practice which, the report says, is followed by many corporations.

The charge is made that the United Shoe Machinery Co. controls the shoe business through patents to the detriment of smaller companies.

It is pointed out in the report that there has been no revision of the patent laws since 1870. During that time, it is argued, fundamental changes have occurred in industrial conditions.

"Chief among these," says the report, "is the rapid growth of the trusts and combinations whose business rests entirely in patents and whose financial and industrial power exercises a dominating influence over many branches of trade."

RETURNS FROM EUROPEAN TRIP.

Edward N. Burns, vice-president of the Columbia Graphophone Co. and manager of the export department, returned to New York recently on the steamer "Franconia" after being marooned abroad since the start of the war and passing through many exciting and well-nigh perilous adventures.

PATHESCOPE PUBLICITY

At Wanamaker's Has Resulted in Tremendous Increase of Interest in the Device—Wanamaker's Auditorium Crowded at Pathéscope Recitals—Put to Practical Use.

During the past month the Pathéscope has been used almost daily to give motion picture exhibitions in the big auditorium of Wanamaker's New York store, and has made a remarkable hit with thousands of spectators who have seen it. Although this instrument is intended primarily for use in homes, schools, clubs, etc., it has sufficient power under favorable circumstances to show pictures to even larger audiences.

In the Wanamaker auditorium a special 6x8-foot day and night screen has been provided, and the photo-drama of "Les Miserables" has been projected thereon every day, one episode at 11.30 in the morning and the other at 2.30 in the afternoon. Beautiful incidental music on the great organ was arranged especially for this Pathéscope production by Alexander Russell, musical director of the Wanamaker auditorium. Slides thrown on the screen between the reels tell the spectators that the Pathéscope is being used in the production of the pictures they are enjoying, and that this instrument is being demonstrated and sold on deferred payments, if desired, in their talking machine department.

The industrial department of the Pathéscope took a motion picture film on August 31 of the beautiful Worth and other Paris gowns and wraps, which the Wanamaker stores were able to get through the blockade from Paris after the war actually broke out. These gowns were first exhibited in the auditorium, and after they were taken to the Philadelphia store the Pathéscope was used to show in motion pictures just how these latest triumphs of the Paris costumers looked.

In one respect the motion picture surpasses the reality, and this is the facility for showing over and over again the same subject for purposes of critical study and analysis. Louis J. Gerson, the manager of the talking machine and Pathéscope departments of Wanamaker's, has been on a vacation in Southern California, where, with a Pathéscope camera, he has been taking motion pictures which will doubtless be shown later in the Pathéscope salon.

ADDITION TO VICTOR PLANT.

Bids have been called for on a new six-story addition to the factory of the Victor Talking Machine Co., in Camden. The building will measure 274x141, will be built of brick and concrete and will cost about \$300,000.

The Silas E. Pearsall Company

Were first in the field as

Jobbers of Victor Products to believe in the Supremacy of the Victor

and are referred to as the house where VICTOR GOODS may be found when a shortage exists. Many dealers have been placed upon our books during the past strenuous six months.

Come in under our wing. We need you to help maintain Our Standard.

It will pay you to enter into correspondence.

SILAS E. PEARSALL COMPANY

VICTOR DISTRIBUTORS

18 West Forty-Sixth Street

(Near Fifth Avenue)

NEW YORK

OUR MOTTO

Correctness and Despatch.

We Specialize Foreign Records, Record Cabinets, Needles, Needle Cutters, Autostops, Corrugated Board Containers and Envelopes.

The Largest Exclusively Wholesale Distributor of Victor Goods in the World

If you can deal with us under the same conditions—and at the same prices—why not take advantage of the superior service which an Exclusive Wholesale Business naturally offers.

Prepare for that inevitable winter shortage.

No matter where you are, remember—that a bit more freight paid—a few more sales made—is the policy that makes for an enduring success.

THE TALKING MACHINE COMPANY

12 NORTH MICHIGAN AVENUE, CHICAGO

FROM OUR CHICAGO HEADQUARTERS

E. P. VAN HARLINGEN, Manager
HENRY S. KINGWILL, Associate

World Office
Consumers' Bldg., 220 South State St., Chicago
Telephone: Wabash 5774

(Special to The Talking Machine World.)

CHICAGO, ILL., September 9.—The local situation in the talking machine trade, viewed in face of the customary dullness of late summer, is quite satisfactory. One or two dealers report business as poor, but the greater number seem to believe that the past thirty days have been at least equal to the corresponding thirty days of last year. The demand for machines seems to run in all classes, but it can be quite safely said that the larger styles are enjoying their share of the calls.

Considerable gloom was cast over the trade recently when the announcement was made by officers of the Chicago Grand Opera Co. that no attempt would be made to offer a season this year. The reason, of course, being the terrible wars in Europe and the fact that many of the song birds are either in the various armies of the old world, held in reserve, or doing nursing work in the overflowing hospitals.

The opera has always furnished a decided stimulus to the sale of operatic records inasmuch as it is the main concern of society during the mid-winter months and such music is tremendously advertised. The dealers will probably call the attention of their patrons to the fact that the only way that they can hear grand opera and the greatest artists of the world is by means of the talking machine, and certainly it is undeniably true that all the opera that Chicago and the West and probably the East will enjoy this year will be from such a source.

Appreciation.

J. B. Williams, of the Wurzburg Department Store of Grand Rapids, Mich., recently wrote the following lines to Charles F. Bauer, local manager of the Columbia Graphophone Co., when placing a preliminary order for fall goods. Mr. Williams said: "Your goods are getting so darned popular here that we cannot keep them on the floor. We presume that the big Columbia advertising campaign has much to do with it. At any rate, the business is seeking us out. Please send as soon as possible the following," etc.

The Victor Multiplex.

L. C. Wiswell, manager of the talking machine department of Lyon & Healy, has issued thousands of circulars calling the attention of dealers to the Victor Multiplex, a device whereby the monthly lists of Victor records may be displayed and referred to in a most facile way. It consists of a

handsome frame which can be attached to a post or the wall by two screws. Six double faced hinges that swing with the slightest touch are arranged in the frame so that they carry the twelve most recent monthly sheets like a large catalog. It is said that whenever a customer comes into a dealer's store the display instantly attracts his attention and, without realizing it, he begins to read the titles of each bulletin. The result is said to be that many sales are made following this announcement of records that the customer was not aware had been issued. The Multiplex is finished in excellent fashion, is well enameled and an ornament to any display room. The price complete is \$8.50.

Mr. Wiswell returned a few days ago from a trip through the East, where he spent a few days at the Victor factory at Camden. Mr. Wiswell noticed an optimistic tone throughout all the trade that he encountered while away. Mr. Wiswell believes that this fall will show the entire trade a most satisfying business.

It is said in the Lyon & Healy retail record department that three of the best sellers recently issued are "When It Is Night Time Down in Burgundy," "You're Here and I'm Here" and "Little Gray Home in the West."

C. E. Goodwin on Quality Machines.

C. E. Goodwin, head of the Phonograph Co., local Edison jobbers, returned from Europe recently, and in a little talk with a representative of The World outlined a few of the noticeable characteristics of the talking machine trade of Europe.

Mr. Goodwin said: "I left the old country just one or two days before the declaration of hostilities, and the ship on which I sailed, the 'Vaterland,' was in mid-ocean before we received a wireless apprising us of the awful calamity that had been precipitated.

"I had very little opportunity while in Europe to study the phonograph business as I should like, but I did notice one thing which struck me most forcibly. That was the prevalence of the cheap machines and the awful results that follow an attempt to give the public what are apparently bargains, but which in the end cause the most unfortunate conditions. Over there the result of the introduction of the inferior machine has cheapened the whole talking machine proposition, and the result has been that there is a distinct

lack of the pride of ownership which exists in this country and which only follows the marketing of the better grade of instruments and encouraging the purchase of instruments that are really worth while. The popularizing of the phonograph in this country from the standpoint of good furniture resulted in its being taken up by the wealthier classes and being installed in a really permanent way. In reply to these arguments I was told that 'you don't know our people,' but I deny that my theory is any more at fault in their case than in our own, and I certainly maintain that the American success in the talking machine business has been the result of placing high-grade instruments in high-grade homes and in the fact that it has been made fashionable with the cultured classes to own a machine of the more expensive type. With the instalment plan so prevalent in this country, everyone can afford to place one of the better instruments in his home, and once it is there the pride of ownership will insure its staying there."

Mr. Goodwin was in France primarily to visit his mother and sister, who have been at the Calot Institute at Birk Plage, France, which is fifty miles south of Boulogne. Mr. Goodwin's people are still at this point despite the fact that the greatest war in history is raging only a few miles to the east. Mr. Goodwin says, however, that he fears little danger of either of the armies making trouble in that neighborhood. "I motored considerably in England and France," said Mr. Goodwin, "and it seems hardly possible that the peaceful agricultural countries and the beautiful farm lands that I traveled through are now the scene of mobilization and strife.

"The month of August has been surprisingly good, with a decided demand running for the most expensive instruments. The sales of the \$250 Edisons are by far in the preponderance. The weekly issue of Edison records has had a pronounced success as well as the system of releasing records State by State."

The Edison headquarters have been greatly improved by removing the offices that were on the second floor to the floor above, giving increased space for the reception of retail record customers. Tables have been placed around in the space formerly occupied by the offices and decorated in excellent fashion, so altogether the change is most commendable.

Cheney Machine Promised Soon.

Prof. Forest Cheney announces to The Talking
(Continued on page 43.)

THE WADE—THE PRACTICAL—THE WADE Fibre Needle Cutter

The WADE embodies the right principle, worked out through long experience. It is simple, durable and accurate. It trims the needle at an angle resulting in the best tone. The WADE cutters are made of the best steel and are absolutely guaranteed.

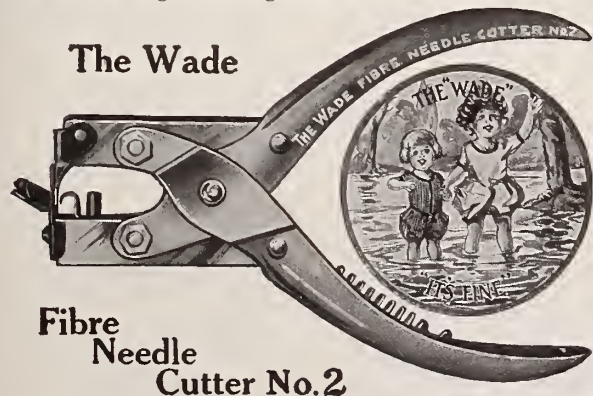

The Wade
Fibre
Needle
Cutter No. 2

The WADE is the most economical cutter. It has a self-acting stop, which prevents waste and enables one to get from 12 to 15 perfect playing points. No. 2 has a double action, making it especially easy to operate and affording the most powerful cut of any tool made. No. 1 is a very popular cutter which has given excellent service.

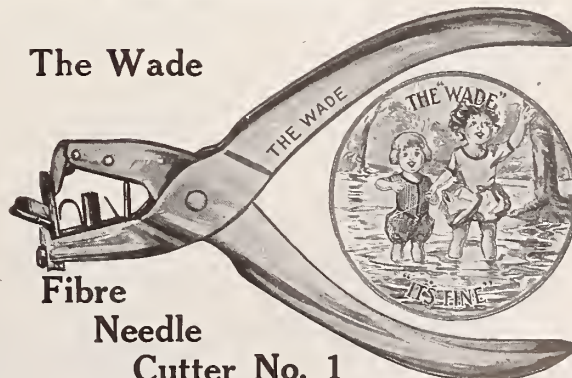

The Wade
Fibre
Needle
Cutter No. 1

RETAIL PRICES—No. 1, \$1.50; No. 2, \$2.00

Order from your regular Distributor—we sell to Jobbers only

WADE & WADE,

3807 Lake Ave.
PHONE, DOUGLAS 8108
CHICAGO, ILL.

TALKING MACHINE dealers can make money by selling the famous Easy-to-play

WASHBURN MANDOLINS

COPY OF FINE WINDOW CUT-OUT, 30 INCHES IN HEIGHT, NOW READY

Washburns
Retail
from
\$15 to
\$150



Easy-to-Play
Instruments!
WASHBURN
MANDOLINS
GUITARS
BANJOS
from
\$15 to \$125
Sold on Easy Payments
VISITORS WELCOME

Splendid
Sure
Profits
to
Dealers

Write for our Special Offer of a Washburn Display Case [occupying only 2 ft. by 2 ft. floor space] containing Six Washburns

ESTABLISHED
50
YEARS

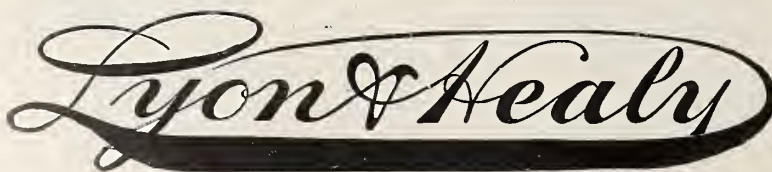

CHICAGO

EVERYTHING
KNOWN IN
MUSIC

FROM OUR CHICAGO HEADQUARTERS—(Continued from page 41).

Machine World that rapid progress has been made in the past thirty days on the development of his machine and that in all probability an announcement will be made in the October issue of The World that will be most interesting.

To Handle the Victor.

The Story & Clark Piano Co. has completed arrangements whereby it will not only handle the Edison line in Chicago, but that in fourteen or fifteen of its other branch stores an Edison department will be instituted. Work on the department in the Chicago store is already well under way. A large sound-proof room is now under construction and will soon be completed. In addition to this there will probably be some additional sound-proof booths. E. M. Love, manager of the Chicago store, has not yet decided who will be in direct charge of the new department.

Columbia Business Prospers.

Charles F. Bauer, local manager of the Columbia interests, reports that beginning with the last week in August there has been an extraordinary rapid increase in the volume of business being done. Mr. Bauer reports that fall orders are coming in in plenty and business undeniably will be of the best the next few months. Mr. Bauer expressed it as his opinion that the approaching season has all the appearance of being a more substantial one than any that the trade has yet enjoyed.

At the Columbia offices the seven most popular records at the present time from the standpoint of sales are: "Cohen at the Telephone," "Puppchen," "Y Come la Va," "Symphony and Moon Winks," "Draming" and "Isle D'Amour" and the "Dorothy Waltzes."

The new Columbia "Meteor" has been received at the local headquarters and has evoked much admiration.

Kimball Department Adds Space.

T. J. Cullen, manager of the talking machine department of the W. W. Kimball Co., announces that his department is to be favored with a large space on the main floor of the company's big building on Jackson boulevard and Wabash avenue in preparation for the holiday trade. There are a number of large sound-proof booths on the main floor that have been used in the past as piano salesrooms. One or two machines will be placed in each of these rooms for demonstrating purposes. The record department will be continued at its present location on the second floor.

Personals and Visitors.

F. A. Copeland, Edison dealer of Elgin, Ill., was a visitor recently.

E. H. Gallup, of Niles, Mich., and J. B. Lundberg, of Chesterton, Ind., were also visiting Edison dealers.

Mr. Gensch, of the Gensch-Smith Music Co., of Milwaukee, Wis., was a visiting talking machine dealer last week.

G. Kempfer, of the Gus Blass Department Store of Little Rock, Ark., was a visiting Columbia dealer a few days ago.

Mr. Leavitt, of the Howard Farwell Co., of Minneapolis, was a visiting Victor dealer.

C. H. Hale, representing George H. Wheelock, Victor dealer of South Bend, Ind., was also in Chicago.

Miss Ida Caldwell, of the Talking Machine Shops, has landed in New York following harrowing experiences in the European war zone, and will proceed to Burlington, Ia., where she will enjoy a long rest.

W. C. Fuhri, district manager of the Columbia Gramophone Co., enjoyed a most invigorating motor trip over Labor Day.

George Cheattle, traveling sales manager for the Talking Machine Co., has returned from a successful trip to the Coast.

Don Preston spent several days in Chicago after an extended trip through Minnesota and Wisconsin.

Archie Mathias, proprietor of the Talking Machine Co., of Minneapolis, sends greetings to his Chicago friends after an automobile trip to the East.

on a trip to the North Woods with his wife and a party of friends. They went in three automobiles.

A. D. Geissler's Trip Abroad.

Arthur D. Geissler, vice-president and managing director of the Talking Machine Co., of Chicago, and the New York Talking Machine Co., of New York City, arrived in the city this week. As a result of the hard work incident to the reorganization of the business of the New York company after the disastrous fire a few months ago, Mr. Geissler went to Europe with his wife intending to spend a week in London and then return to the States. He was almost a nervous wreck and wanted the trip on the water more than anything else. He got caught in the war whirl, went over to Paris, but got out hastily the next day, went back to London and was couped up there two days before he could get passage to America, which he finally did on the "Campania." It wasn't much of a rest after all, inasmuch as he had Mrs. Geissler with him and they had all sorts of disagreeable and almost perilous experiences, losing their baggage among other things. Mr. Geissler says that there was nothing like the feeling of the Germans toward the French as the hatred of the French toward the Germans, at least before the war broke out. The general feeling in England and France, of course, is that Germany was the means of starting things. He was enthusiastic regarding the sane but patriotic spirit animating England in this crisis, and also spoke of the magnificent manner in which the English sought to alleviate the discomfort of Americans temporarily sojourning there, and said that everybody extended every courtesy possible to the visitors from across the sea and aided them in every way they could. Naturally he was not in the mood to get around in the talking machine trade much, but said that it was a surprising thing that although the Gramophone Co. of London was suffering enormously from the war because four-fifths of its business is outside the British Isles, still the local business in England continues remarkably good in spite of the war.

Mr. Geissler was very much pleased at finding the excellent reports of business made by both the New York and Chicago companies on his return. August and September so far are better than last year, and advance orders are coming in in a most gratifying way.

Wade Cutters in Demand.

According to the belief of S. O. Wade, manager of Wade & Wade, manufacturers of fibre needle cutters, the war in Europe will have no effect upon the talking machine business in this country, and that without a doubt the American talking machine dealer is to see a tremendous fall.

"I have just returned from a trip through Illinois," said Mr. Wade to The World, "and I must say that despite the war and rumors of war, I never found conditions more favorable or the dealers more optimistic. They have placed orders for the Wade cutter that have broken all records and which certainly were most encouraging to me. The great contributing reason for the demand for our cutter is to be found in the guarantee that is issued on each one. We will positively repair free of charge any Wade cutter that should get out of order. This we have done for a long time, and it must be said for our product that the time we have spent on repairing cutters has been almost nil, as there have been but three or four to repair. When the dealer has a talking point such as this it is very easy for him to dispose of a superior cutter. Our factory is going to be taxed to the utmost this fall, and we are advising dealers and our jobbers to place their orders early so that none may be disappointed or delayed in receiving their stock."

Describes Model Record System.

The Talking Machine Co., exclusively wholesale Victor distributor of this city, has become famous not only because of the big volume of its business and for prompt service, but because of the pains it has always taken to instruct its dealers in the best and most approved methods of merchandising, giving them the advantage of carefully worked out systems and even furnishing them at actual cost

TIME TO PLACE HOLIDAY ORDERS.

Salter Manufacturing Co. Advises Dealers to Order Cabinets Early Owing to Extensive Advance Orders on Hand—Handling Extensive Line—One of the Popular Styles.

(Special to The Talking Machine World.)

CHICAGO, ILL., September 8.—The Salter Manufacturing Co. reports that its fall business has already shown a nice increase in spite of the war conditions and the sales on cabinets to hold Edi-



Salter Cabinet, Style 790.

son, Victor and Columbia machines promise to be gratifyingly large between now and the holidays.

The accompanying illustration of the Salter cabinet No. 790 shows a record cabinet that is receiving an unusual call lately. The cabinet holds 112 records either Victor or Columbia, and is most suitably used with some of the smaller machines. The cabinet sells very reasonably and is attractively finished for its price. The top is fifteen inches square and an efficient indexing system and accommodations for needles are other features.

On other pages of this publication will be found three advertisements by this concern. Each one has a story to tell to the dealer, and each one shows one of the leading cabinets now being sold to each particular class of trade. Owing to the extensive advance orders that the Salter Manufacturing Co. has received it advises dealers to get in their holiday orders well in advance with privilege of early shipment so that dealers will be sure to have cabinets on their floors when they want them. Catalog and full information on Victor, Columbia and Edison cabinets can be had by addressing the Salter Manufacturing Co., 339 North Oakley boulevard, Chicago.

many things in the way of stock shelving, stock books and other devices calculated to enable them to transact their business at the least expenditure of time and labor.

The Talking Machine Co. has gone further than this. It has even collected from many sources tried and true selling campaign ideas which it has placed at the service of its dealers. It has, indeed, had in operation for a couple of years a regular correspondence course (it amounts to that) on selling, store keeping, etc., and its occasional bulletins on such topics are always awaited with the keenest interest by Victor dealers who obtain their goods from the Talking Machine Co.

"A Practical Record System for Victor Dealers" is the title of the latest issue of the T. M. Co.

(Continued on page 44.)

FROM OUR CHICAGO HEADQUARTERS—(Continued from page 43).

press. In it the Talking Machine Co. tells things borne of long and actual experience, which, one may easily imagine, if followed out by the recipients, would be very likely to convert an indifferent record business into a big, fine paying one. We can't go into details here, nor would it be advisable, but it not only tells how to properly care for stock with a description, incidentally, of the accessories to that end which the company is able to furnish at cost and merely as a matter of accommodation to its customers, but also gives a plan by which the selling value to the dealer of various records can be determined and thus avoiding stocking up with records which experience may prove are not good sellers in their particular locali-

ties. The tabulation and permanent recording of experience is the foundation on which the especial record system provided for its dealers by the Talking Machine Co. rests. Of course, if by any reason any of the company's customers have not received this invaluable bulletin they have only to write to the company."

Exhibiting at County Fairs.

All through the country dealers have been making good exhibits at the county fairs. B. H. Henderson, of Fond du Lac, Wis., had an unusual booth at the fair there, at which he exhibited Victor goods. Tiffau & Kemp Mercantile Co., of Marshfield, Wis., also had a good exhibit at the fair in that county.

INTERESTING EXHIBITS AT CHICAGO BUSINESS SHOW.

Columbia Co. Make Fine Display of Dictaphones, While E. C. Barnes & Bros. Display the Edison Dictating Machine, Including the Telescribe, the Latest Edison Accomplishment.

(Special to The Talking Machine World.)

CHICAGO, ILL., September 11.—The annual Business Show, in which are displayed office labor saving devices, business systems of all kinds, etc., was in progress this week at the Coliseum. There are splendid exhibits of Columbia and Edison dictation machines, as usual.

The Columbia exhibit is in charge, as usual, of W. W. Parsons, district manager for the Dictaphone department of the Columbia Graphophone Co., and he is efficiently aided in the work of giving the Dictaphone adequate exploitation to the thousands who visit the show by the following people: E. A. Parsons, A. B. Walker, Frank J. Clark, George Ingalls, P. A. Miller, Grace Carpenter, E. F. Baumann, F. Casseday, E. C. Allen, May L. Stuetzer, Miss M. Norgate and R. G. Winter. An essential trade-mark feature of the exhibit was a magnificent American eagle suitably decorated with American flags and "Columbia" insignia. A full and complete line of the latest models of Dictaphones were shown, the most important novel features being the new hand control, the new light weight hearing tube and the modifier for regulating the volume of sound on the Type E machine.

At the Edison disc dictating machine exhibit, in charge of E. C. Barnes & Bros., the Chicago representatives, interest largely centered in the Transophone, the new device which enables the operator to repeat the dictation by a light touch on an electric button beside the typewriter keyboard in place

he was assisted by J. S. Pahlman, O. C. Dentzer, A. H. Fulton, K. H. Kammerer, E. Humphrey and George Field. Nelson C. Durand, third vice-president of Thomas A. Edison, Inc., and Mr. Holland, the Edison Co.'s laboratory staff engineer, were

that perfection in telephonic communication would be reached only when means were discovered for combining the telephone and phonograph in order that telephone messages might be properly recorded. The fact that at the present time the telephonic system transmits 60 per cent. of all forms of communication in the United States, totaling fifteen billion conversations a year—a grand total in excess of the number of telegrams, letters, railroad passengers in the same period—makes the fulfillment of Mr. Edison's prophecy at this time particularly valuable and important. In general correspondence we make copies of important letters and keep them on file. It is also possible to keep accurate records of telegraph messages, and it has only been in the telephone that an absolutely perfect record was not possible to procure. The Edison Telescribe has solved this problem.

The Edison Telescribe comprises an Edison dictating machine, which is especially equipped with telephone recording appliances, and a glance at the accompanying illustration gives an excellent idea of its general appearance.

In describing the Telescribe and its uses, Nel-



Dictaphone Exhibit by the Columbia Graphophone Co.

visitors here the first part of the week. While in Chicago they demonstrated at the offices of E. C. Barnes & Bros. the new Telescribe for reproducing telephone conversations,

The Telescribe, the latest accomplishment of

son C. Durand, third vice-president of Thomas A. Edison, Inc., said:

"The dictating machine is equipped with a micro-recorder, which swivels into place over the wax cylinder, and is wired up with the Telescribe on the user's desk. In short, the Telescribe is a complete telephone extension run with its own small batteries, concealed in the casing.

"A telephone message is telescribed in the following manner: The receiver of the regular desk telephone is removed from the hook and placed in the socket of the telescribe. In this way the acoustic connection to the dictating machine is made without danger of criticism from the telephone company, as the instrument is neither mechanically nor electrically connected to their lines. The user then takes up a small receiver, which is part of the Telescribe, and gives his call to the exchange, while starting and stopping the dictating machine by means of two small buttons on the Telescribe in order to record the conversation between pauses or delays, and avoiding any waste of running the wax cylinder meanwhile.

"In this way both sides of the telephone conversation are recorded, including all the evidence of the central operator's voice in making the connection. The dictating machine becomes in reality an 'eavesdropper' on the telephone line.

"There are many telephone subscribers in every locality who have monthly toll bills of hundreds of dollars, evidencing the practice of conducting an important part of their business by 'conversations.' Brokers, in many instances, do buying and selling by telephone from both local and outlying territory; advertising agents secure the approval of their clients at distant points by reading late copy on the 'phone; purchasing agents place orders and secure promises and prices of importance as a daily occurrence through the telephone. But the special applications of the



Thomas A. Edison Testing the Telescribe—Exhibited at Business Show.

of the old operation of interrupting the work to reach out and move a repeating lever. Besides this, the new speaking tube start and stop and the new covered gearing excited great interest. E. C. Barnes spent much time at the booth himself and

Thos. A. Edison, and which has been demonstrated very successfully in various cities of the country, is rather a development of the property made by Mr. Edison in 1876 and an entirely new invention. At that time Mr. Edison predicted

Telescribe will not be as important as the ordinary uses which every large organization finds for recording wire conversations in the course of their ordinary day's work.

"The Telescribe will place the use of the telephone in a more serious light in business. After a conversation the dictator will turn to his dictating machine and confirm his message in the usual manner covering the general understanding, while he will mark his letter: 'Telescribed on the Edison dictating machine.' To the person receiving this confirmation, the question of its correctness will be unquestioned, and give that feeling of business security to both sides, which is now missing, and in some cases may be even depended upon if denial of telephone understanding is expedient.

"The wax record, containing the telescript and the dictated reference, may be acknowledged indefinitely for reference, but future acknowledgments and circumstances reduce the time for holding the records to only a few days in most instances."

MAY MAKE TALKING MACHINES?

Rumor that the American Can Co. Will Go Into the Talking Machine Business Denied by the President of the Corporation—Admits, However, Construction of Sample Talking Machines at Maywood Plant.

(Special to The Talking Machine World.)

CHICAGO, ILL., September 9.—Rumors have been afloat for some time that the American Can Co., of this city, which is said to be capitalized at \$90,000,000, would enter into the manufacture of talking machines upon a large scale. Officials of the company have denied any definite decision, but have admitted that such a step had been contemplated.

It is interesting to note in this connection the report recently issued in an industrial periodical, which stated that the company had embarked upon the project upon a large scale and that both machines and cabinets were in the course of manufacture at the company's plant at Maywood, Ill. The machines, according to this report, were to be all metal, according to this report, were to be imitations of mahogany, oak and other woods, after the fashion of fire-proof office furniture. It was also said to be definitely known that a contract had been placed with the American Can Co. by a large merchandise house for the delivery of 400,000 small machines of light construction and that the contract price for the lot was \$1,000,000 or \$2.50 each.

The statement was also made in the article that a complete line of machines would be turned out at ridiculously low price.

Mr. Harbeck, president of the company, denied the story emphatically, making the single admission to the representative of The World that the company had under construction one or two sample instruments at the Maywood plant and would, if they prove successful, place the proposed side line in a favorable light before the board of directors.

The manufacture of records has not been considered by the company.

A LIVE SELLING SYSTEM.

Capable Saleswoman Places Victrolas in Homes of Prospects and Finds That the System Leads to Many Sales—Uses Automobile to Advantage in Covering Territory.

As indicative of the progressiveness and up-to-date methods that characterize the sales methods of many live-wire Victor dealers, the plan utilized by Miss Hanley, a capable saleslady connected with the Kelly Music Co., of Jersey City, N. J., is well worth attention.

Realizing that the placing of a Victrola in the home of a prospect is one of the best available means of closing a sale, Miss Hanley called into play an automobile which she owns and decided to employ it in the pursuit of Victrola business. She invariably carries machines with her for demonstrating purposes and the novelty of the plan has enabled Miss Hanley to achieve a marked success since she inaugurated the idea in May.

Miss Hanley has found that wherever she can

get a machine into the home of a prospective buyer the sale is about 75 per cent. made, and it is hardly necessary to state that Miss Hanley experiences no difficulty whatever in supplying the 25 per cent. salesmanship necessary to give the proposition a 100 per cent. average. The use of an automobile in soliciting machine sales has long been advanced by the majority of Victor jobbers and the most successful dealers, and Miss Hanley's successful experience well evidences the practicability of such aggressive methods.

NEW RECORD DISPLAY CARDS

To Enable Dealers to Feature Every New Victor Record Supplied at Nominal Cost by the New York Talking Machine Co.—A Permanent Device to Increase Record Sales.

The New York Talking Machine Co., 81 Chambers street, New York, Victor distributor, has just announced to the trade an attractive and per-

In addition to displaying new records by means of these title strips, Sales Manager Moody intends to furnish the dealers with title strips of standard selections from the Victor catalog which they may feature in addition to the new records under a sub-head title strip apropos of the character of the records. Mr. Moody also points out that the dealer will be furnished with sixty strips each month, although there are but an average of forty new records listed in the monthly supplements. These extra slips will permit the dealer to feature two popular selections on one record, if there is a sufficient demand for these selections in his vicinity.

In furnishing title strips for all the new records, Mr. Moody takes cognizance of the fact that the popularity of certain classes of records varies in different sections of the country, and that with a full complement of title strips, the dealer may feature those selections which are in demand in his individual territory.

EASTON-MUMPER.

The marriage of Miss Helen Easton, youngest daughter of Edward D. Easton, president of the Columbia Graphophone Co., to Norris McAllister Mumper, was solemnized Saturday evening at the home of Mr. and Mrs. Edward D. Easton, at Arcola, N. J. The wedding was an informal one, the relatives of the bride and groom being the only invited guests besides several of the executives of the Columbia Graphophone Co. and their wives.

Hewlings Mumper, a brother of the groom, acted as best man, while the ushers were Donald Hoise, Paul Renn, Ogden Hewitt and Mortimer D. Easton, manager of Dictaphone advertising. Mrs. Mortimer D. Easton was the matron of honor, and Miss Barbara Bispham, Miss Alice Mumper, Miss Barbara Trego and Miss Elizabeth Terhune officiated as bridesmaids.

The house was beautifully decorated with wreaths and flowers, and Prince's Orchestra furnished the music. After their honeymoon, Mr. and Mrs. Mumper will reside at Arcola, N. J. Mr. Mumper is a member of the Dictaphone staff.



Effective Victor Record Display Card. A perpetual display-card featuring the new Victor monthly records, as shown in the accompanying illustration. Title strips for every new record listed in the monthly Victor record supplement will be sent to the dealer at a cost of 75 cents per month on a yearly basis, while the easels will be supplied free.

Effective Victor Record Display Card. A perpetual display-card featuring the new Victor monthly records, as shown in the accompanying illustration. Title strips for every new record listed in the monthly Victor record supplement will be sent to the dealer at a cost of 75 cents per month on a yearly basis, while the easels will be supplied free.

LONG CABINETS
A NEW PATTERN FOR 1914-15

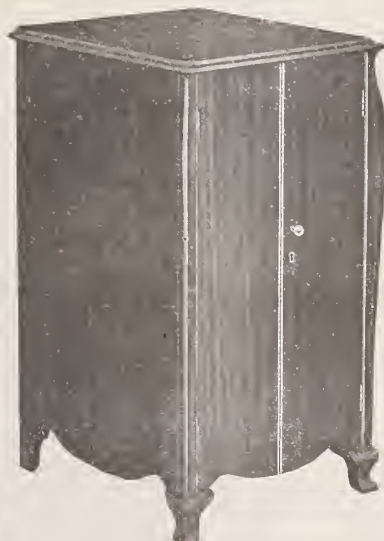

D70

FOR VICTROLAS VIII. and IX.
Mahogany, Fumed Oak, G. O. and W. O.

Write for new illustrated matter and it will be cheerfully sent to you.

Kindly anticipate your requirements for the Fall and Winter, naming dates for shipment.

The Geo. A. Long Cabinet Co.
Hanover, Pa.

Address **Clement Beecroft, Sales Manager**
309 W. Susquehanna Avenue, Philadelphia



Each buyer and each seller of a Columbia Grafonola "Nonpareil" is always satisfied—the one with the quality and the other with the profit.



(Write for "Music Money," a book "full of meat" for those dealers interested in quick and frequent turnover of capital.)

Columbia Graphophone Company
Woolworth Building, New York

HAS MOST ATTRACTIVE QUARTERS.

Transformation of Columbia Co. Warerooms in St. Louis Into Most Artistic Emporium Brings Many Compliments to Manager Reid.

(Special to The Talking Machine World.)

St. Louis, Mo., September 10.—Manager Irby W. Reid, of the Columbia Co. here, has won the reputation of a wonder worker because of his transformation of the dark and rather dilapidated warerooms of the Columbia Co. into one of the neatest and cleanest stores in the city and second to none in this section as a talking machine store.



Irby W. Reid.

The transformation was accomplished with only partial interruption of business and at no time was any department put completely out of the running, although for some time the retail department was seriously handicapped, but under the leadership of R. W. Duffy made a good showing for the period.

The new store was planned by Mr. Reid to the smallest details. It bears small resemblance to the old, as from the former two show windowed front, with a door between them, it has been changed to one large window, through which not



Remodeled Warerooms of Columbia Co. in St. Louis.

only the display can be seen but the entire store room, with a recessed door at the east corner of the front.

The picture that greets you as you step inside the door is a restful one. The handsomely enameled woodwork, finished in a glossy soft gray blends well with the gray and green wall finish and rugs, and the thirty varied style machines exhibited in the main display space, with the heavy mission furniture, supplies plenty of decoration.

There is but one desk in sight, and you must look a second time to see where Sales Manager Duffy is watching operations, and the planning of the six demonstration rooms artfully overshadows the office suite, which, however, can easily be found by the customer wishing to make a payment.

The lighting is entirely by the overhead system, and while it shows off the machines to excellent advantage, does not obtrude upon the visitor, who is unconscious that artificial light is in use.

The new arrangement has removed the dictaphone department, which formerly had the best space in the warerooms, to the second floor, where that office force can work without interruption. The wholesale office is in the rear of the demonstration rooms, safe from interruption. Manager Reid's executive office has a peculiar arrangement of doors whereby he can completely isolate himself behind his reception room, or he can open

HOW AGGRESSIVENESS WON OUT.

Interesting Story Related by V. W. Moody Tells How a Well-Known Dealer Has Won Great Success from a Modest Beginning.

As indicative of the success that an aggressive Victor dealer can achieve in a comparatively short while, V. W. Moody, sales manager of the New York Talking Machine Co., 81 Chambers street, New York, Victor distributor, relates the following incident:

About a year ago a man visited the company's headquarters, who had decided to embark in the Victor business, and desired to place an initial order and ascertain the necessary details. Upon inquiry he stated that he resided in a city of about 30,000 population, and that he had no definite ideas regarding the Victor business other than that an initial order of \$300 seemed to him to be a proper start.

Mr. Moody thereupon pointed out that there were something like 3,000 records and 17 machines listed in the Victor catalog, making an initial order of \$300 decidedly inadequate and well-nigh insuring failure in a city of 30,000, rather than success. The prospective dealer realized the logic of these figures and placed an initial order of \$600. He also secured an intimate knowledge of the sales and stock policies of approved merit, and, fired with an ambition to succeed, opened his store.

His road at first was naturally somewhat difficult, but his success is represented in the fact that during the past sixty days he placed orders for \$2,000 worth of stock, and his latest inventory showed a stock of over \$3,000. Notwithstanding that this is only his second season in the business, he has just placed advance orders for machines alone to be shipped during September, October, November and December, totaling more than \$6,000. This dealer pays a salesman \$30 to run his department and his manager has two assistants. All this was accomplished in a year as a result of aggressive methods and an appreciation of the

them and see every part of the floor at a glance.

The record arrangements in connection with the demonstration rooms have attracted considerable attention. The rack is of easy access to all of the booths, holds a remarkable number of records, and also is a means of ventilation for the booths.

The new store room has materially aided in the business promotion plans and customers who had, from their own admission, recently been buying at the more attractive department store booths, are coming back to the main wareroom. "I do not see how you do it!" is the often repeated exclamation of these old friends.

scope and magnitude of sales possibilities in the Victor field.

IMPROVEMENTS OF INTEREST.

Among the new inventions of the past month is the Uffner patented record album, designed to hold talking machine records in either the 10 or 12-inch sizes. The new feature that is of special interest is the method of binding the leaves, which are held in place with steel instead of glue. Holes are cut in a sheet of steel, lengthwise, so that two leaves just fit in, the sheet being fastened to the back of the album, the back always being the same size whether the album contains records or not.

The patent on this album was secured by the head of the Uffner Album Co., 77 Grand street, New York, and from the orders already received from those to whom he has shown the sample, it would indicate that there is a remarkable volume of business to be had from dealers who want albums of durability as well as attractiveness.

The weaker a man is the stronger his habits grow on him.

**PHONOGRAPHISCHE
ZEITSCHRIFT**
BERLIN C. 19, GERMANY

The oldest and most up-to-date trade paper covering the talking machine line published in the German Language.

PUBLISHED WEEKLY. FOUNDED 1900

Circulates all over the world.

SPECIAL EXPORT NUMBERS appear in four different languages at regular intervals.

Subscriptions for this talking machine publication 10 Marks yearly. Sample copies sent free.

FROM OUR EUROPEAN HEADQUARTERS

2 GRESHAM BUILDING, BASINGHALL STREET E. C., LONDON, W. LIONEL STURDY, MANAGER.

General Effect of the War on the British Talking Machine Trade—Noticeable Inclination to Make the Best of Conditions—Probable Scarcity of Supplies—Regarded as an Opportunity for British Manufacturers to Extend Trade—Sidelights of War Situation—Demand for Patriotic Records—Otto Heine-mann Praises American Business System—W. H. Reynolds' List of Supplies—Specialties for the Colonial and Foreign Trade—Recent Additions to Columbia List of Artists—New Products Recently Put on Market.

(Special to The Talking Machine World.)

LONDON, E. C., ENG., September 5.—Hard upon the dispatch of my last report came the dreaded announcement of war between the first nations of Europe, and, as may be imagined, considerable nervousness immediately reigned in London gramophone trade circles. At such a time one is perhaps inclined to take anything but a dispassionate view of things. It is the more difficult to remain calm under circumstances that so closely affect the foundations of commerce, even the very existence of nations, and self-restraint is one of the first of many things to which the Britishers have now schooled themselves. This is no time or place for politics; the sword is the arbiter of our fate and our trade prosperity, and at that we must leave it, in the sure confidence of ultimate victory.

First Panic Over War Short.

Received at first with expressions of dismay, the news that war had been declared by England at the very opening of our trading season, which promised so well, naturally took gramophone men some time to recover from. The market became slightly panicky, but quickly recovered, thanks largely to our inherent adaptability to make the best of things. It was generally felt that the gramophone industry would be one of the first to suffer, and efforts were made to meet the situation in a manner best calculated to neutralize undue depression. It is satisfactory to know that these efforts have met with a fair measure of response from retailers, who, however, are handicapped in many ways. All said and done, sales are nevertheless abnormally slack. True, one does not expect great things on the retail side at this period even under normal conditions, and I should not be presenting a fair view of the situation were I to gloss over the uncertain position in which all find themselves despite every endeavor to steady things. This war of the nations seems likely to last for a considerable period. The longer it goes on the greater is the dislocation of business and consequent unemployment. Thousands are out of work already, more are on reduced wages, while the people generally—not unnaturally perhaps—are prone to conserve their financial resources.

With the spending power of the masses thus restricted, especially in regard to luxuries, gramophone trade is suffering more than most industries. The outlook for this season is therefore not very encouraging. Record factories are still running, in some instances, on a reduced basis of production, which latter is mainly confined to the pressing of patriotic records, the demand for which is excellent. The national anthems of the Entente powers, British national airs and martial songs, etc., are selling very freely, not to mention that last season's pantomime favorite, "It's a Long, Long Way to Tipperary," which seems to have been adopted by our troops as a war song. But this business will not keep things going, and the position is such that almost every firm has either reduced its staff or, by mutual agreement, the wage bill, in a praiseworthy desire to cause as little distress as possible.

The Question of Supplies.

Another feature of trade importance is the question of supplies. The German market, from whence came a large proportion of complete machines, parts and accessories and records, is of course entirely closed. Some firms have goodly stocks on hand, while others find their warehouses more or less depleted. Serious as this aspect is, there is a confident belief that we shall get along all right by the aid of Swiss firms who specialize on the making of motors and gramophone accessories. Owing to the Swiss mobilization there is, however, bound to be a shortage of supplies for some time. Here in England we have certain resources for the manufacture of motors, and this trade will doubtless receive a great impetus. We can, of course, take care of the manufacturing of cases, cabinets and other necessary parts, but for sound arms, boxes and many accessories we shall perhaps find ourselves in a quandary. These latter items have not been cultivated to any great extent by British makers, but with the Germans their manufacture has become a fine art.

The newspapers are waging a strong campaign against everything German, and already one learns the response is great in many departments of trade.

This has not to any great extent touched the talking machine trade, but, speaking dispassionately, there is bound to be a certain amount of prejudice against buying German goods, and we see in this a good opportunity for all-British manufactures. We may be sure that every possible advantage will be taken of the situation, but it would give our manufacturers encouragement to invest large sums in productive machinery could they only rely upon excluding German goods from this market by a tariff imposition on manufactured articles—complete or in parts. Space forbids the further development of

this line of thought. We have to grapple with existing conditions, and it behooves all to do each their share toward allaying the disadvantages under which gramophone trade now suffers. We must keep the trade flag flying at all costs, and though heavy troubles may beset us in the future the best service is to maintain a cheerful mien against the time when trade stagnancy shall have given way to the inevitable resumption of its normal trend. Elsewhere we deal with oversea conditions and the possibility of capturing a considerable proportion of the trade which has previously gone to Germany.

Some Sidelights of War Situation.

The British Government has under consideration a patriotic offer from "His Master's Voice" Co. to loan the use of its City road premises, which have a floor area of some 30,240 feet, until the end of the war, or until the Seventh and other battalions have been completed. Business would be conducted from the Hayes factory.

In appointing a receiver for a piano company with a German name, Justice Shearman said he thought the business, being beneficially owned by foreign enemies (sic), could not be carried on at all without an official license. The Government would give that authority if it were satisfied that no moneys would be remitted to the alien enemy which owned it. To keep a profitable business going he would appoint a receiver, who must undertake that all moneys be kept in this country.

The commercial activity of a number of gramophone firms here is neutralized through lack of supplies from Russia, Germany, France and Switzerland. An early resumption of exports from the latter country is possible.

S. W. Dixon, a director of the Gramophone Co., Ltd., has volunteered for active service. As a captain with the 13th Manchester Regiment, Mr. Dixon served with distinction throughout the South African war.

Many German and Austrian members of the trade have gone to rejoin "the colors" of their respective countries. One can only regret the necessity for their display of patriotism. It is quite possible that some were detained in England as prisoners of war.

Several German gramophone men have sought British nationality; others are out under police "license" and must not travel more than five miles per diem.

Chappell & Co. and other music firms intimate they will not close up factories or dismiss employes during the war. This, however, would not prevent, where necessary, some reduction of wages in order to keep things going and avoid unnecessary distress.

(Continued on page 48.)

"RENO, THE MAN OF MANY PARTS"

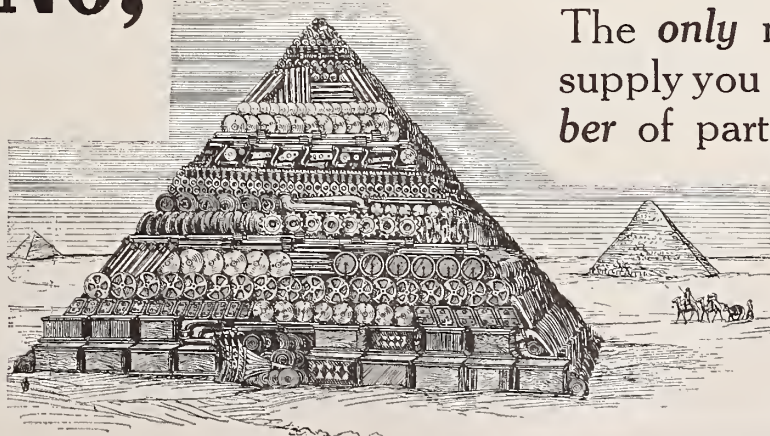

The *only* man in the world who can supply you with *one* part—or *any number* of parts for *any* Talking machine ever made from Adam to Edison-Roosevelt.

64 Page Catalogue Yours for Asking

W. H. REYNOLDS, Ltd.
"KNOTASLEPE"
London, England

FROM OUR LONDON HEADQUARTERS—(Continued from page 47).

It is reported that the French factory controlled by Carl Lindstrom (Berlin) has been completely destroyed.

Harth & Dubb, of City road, agents for the Russian "Syrena" record, will close up for the time being.

The Continental factories of the sister companies of the "His Master's Voice" corporation are, as may be imagined, somewhat disorganized. At Hayes, London, many men are reported suspended from work for the moment.

During the first week of the war public opinion was so bitter against everything German that an all-German program arranged for performance at the Queen's Hall promenade concerts was abandoned. That musical art may reasonably be exempt from the atmosphere of national strife is assured by the telling protests immediately lodged against such an absurd ruling. Commerce, however, is a different thing, and Chappell & Co. announce they will never again allow German pianos on the Queen's Hall platform.

A royalty on every "Regal" war record sold goes to the Prince of Wales' Fund. The Columbia Co. advises me it has already sent sixty guineas on this account.

Among well-known composers, singers and musicians at the front are Rachmaninoff, Chaliapin, Siegfried, Wagner, Kreisler, Ysaye and brother, two sons of Dr. Hans Richter, Paul Franz, Dohnanyi and practically all of the male contingent of the Russian opera and ballet.

"Business as Usual" is our motto. In the form of adhesive stamps it is being used by many firms on memo. forms, invoices and publicity matter.

Official Ruling Anent Trading with the Enemy.

The explanation of the proclamation against trading with the enemy is officially explained as follows: "The important thing is where the foreign trader lives, and not his nationality. There is no objection to trade with German or Austrian firms in neutral or British territory. Trade with the branch of a hostile firm in neutral or British territory is permissible so long as its head office

is not involved. Contracts with firms in hostile countries cannot be performed, and payments ought not to be made during the war. There is no objection to paying for goods delivered or services rendered before the war."

Issues List of Patriotic Records.

The British Zonophone Co. has issued a very strong list of patriotic records, including all the latest war songs of interest. Having always paid great attention to this class of music, the Zonophone people did not have so much new recording to do as other firms when war was declared. During all the years of its existence this company has been steadily bringing out records of patriotic flavor, and thus prompt and complete deliveries are assured. Further new issues will be made known shortly.

"H. M. V." War Records.

A strikingly patriotic list, emblazoned on its front cover with the flags of Great Britain, France, Russia and Belgium, has been issued by "His Master's Voice" Co. As a piece of publicity literature it is altogether attractive and makes a most effective showing. Its contents are even more attractive, for in quality and numbers the records itemized represent, perhaps, the finest and most complete aggregation of martial music ever embodied in one supplement. There is to be noted the national anthems of Britain, Russia, France, the now famous "God Save the King" record by Clara Butt; among a host of other songs calculated to inspire the patriotic ardor of gramophonists none will receive greater welcome than the series of six records on national service by Field Marshal Lord Roberts, V.C., K.G., etc. These discs have reached tremendous sales figures and can scarcely be pressed quickly enough to satisfy all wants.

Interest to Oversea Buyers.

Elsewhere in this section will be found an announcement by O. Ruhl, Ltd., which makes a special appeal of interest to oversea buyers who find themselves short of supplies through the closing of the Continental markets. An up-to-date

factory, equipped with modern plant, at Hertford, England, gives employment to a large number of Britishers, and the company informs us it is in an advantageous position to handle the colonial and foreign trade for records and machines promptly and efficiently. Notwithstanding the general trade depression in this country, its factory is working on full time, and it is hoped to so continue throughout the crisis.

Beka records are, of course, favorably known the world over, and buyers will learn with pleasure of the company's recent issue of innumerable patriotic numbers, the various national anthems and latest war ditties.

An interesting announcement is also made regarding disc instrument trade in the oversea markets. Full particulars are obtainable from O. Ruhl, Ltd., 77 City road, London, E. C.

New Company Incorporated.

W. J. Elliott, Ltd., musical instrument manufacturer; capital, £10,000. Office, 16 Chequer street, St. Albans.

Martial List of Favorite Records.

The demand for patriotic titles has moved our manufacturers to unusual exertions in the quick production of suitable records, and well on time comes an "extra special" supplement from the Favorite concern embodying all the very latest martial airs and some of the good old, yet ever-green, selections which, perhaps, the public loves the best. On record 733, for instance, we find such popular numbers as "Bravo Territorials" and "An Englishman's Home," both fervently rendered by Harry Thornton. No. 730 bears the national anthems (in part) of the Triple Entente powers, by the Favorite Military Band, with vocal effects, accompanied by "Tommy Atkins," sung by Jack Smithson. A very special disc, No. 712, gives "God Save the King," "Rule Britannia," Russian National Anthem and "La Marseillaise"—all beautifully rendered by the Favorite Elite Orchestra. Other records carry "The Bulldog's Bark," "Sons of the Sea," "Voyage on a Troopship," parts 1 and 2; "Three Cheers for the Red, White and Blue,"

"WAKE UP ENGLAND"**THE BEST****Double Side Record**

Genuine British all through—
No German capital or influence.



(H. M. THE KING) The Prince KNEW
(When Prince of Wales) —Little notice was
then taken—But now—Germany and its
works are shown up.

Up-To-Date

in all lines for

English Speaking People

all over the world

This trade-mark in center of each record is a certificate of Highest Quality, Smoothness and Durability. Manufactured for us by I. E. Hough, Limited, Edison Bell Works, London. We have a large and exhaustive catalogue. A new, up-to-date list of patriotic songs, bands and descriptive selections called for by the great British people and the English-speaking world in consequence of the iniquitous war waged against us.

One thing—we shall be "Top Dog" yet, sooner or later.

We will willingly send full catalogues and examples of our "patriotics" to any of our U. S. or Colonial friends on receipt of 40 cents each, carriage and duty paid.

We are devoting all profits on these to the relief of distress caused by the war.

Address **WINNER RECORD CO., CAMBERWELL, ENGLAND**

"A Soldier's Song," "So You Want to be a Soldier, Little Man." On No. 735 the famous Billy Williams offers two rollicking songs, "I Shall Have to Ask My Mother" and "They Can All Do as They Like with Me." A sure seller! Finally, we must accord special praise to the brilliant work of the Favorite recording expert, markedly noticeable throughout the whole list. It should be mentioned that Favorite records are of entirely British manufacture.

"His Master's Voice" Records for September.

Notwithstanding the dislocation of general business conditions, "His Master's Voice" Co. intends to offer its dealers a continuance of good record issues, and in this regard has announced a pleasing list of new titles for September. The list is not so large as would have been produced under normal conditions, but its attenuation is more than counterbalanced by its high standard of quality throughout.

Under the baton of Landon Ronald the New Symphony Orchestra gives an excellent performance of the Pizzicato from "Sylvia" (Délibes); John McCormack, the eminent Irish tenor, in company with Mr. Kreisler, the violin exponent of world fame, who by the way is now at the front, contribute the "Angels' Serenade" (Braga), with piano accompaniment. It is a record of exceptional beauty and will undoubtedly enjoy a wide sale.

There are to be noted some choice vocal records, and in the double-sided section many instrumental numbers of interest. Subjoined is the complete list:

Twelve-inch single-sided: "My Lady's Bower" (Hope Temple), Stewart Gardner; (a) "The Sandwichman—Bow Bells," (b) "The Fortune Hunter—Bow Bells" (Withby), Harry Dearth; "The Promise of Life" (Cowen), Mme. Alice Larkin (with orchestra and organ accompaniment); "The Day Is Done" (Löhr), Baker and Wheeler; "Good-Bye, Summer, So Long, Fall" (Wenrich), Miss Ethel Levey; "I've Seen It on the Pecheres" (Clare), Tom Clare, with piano ac-

Merely A Statement of Fact

The British Colonies and dependencies import annually many thousands of pounds' worth of gramophone products, a large percentage of which emanated from Germany.

Now that this source of supply is cut off, who is going to fill the breach?

This question must give British houses food for profitable thought.

But the opportunity for action is not tomorrow or the day after, it is Now!

The trade routes are open and we venture to think will so remain.

You can get into touch with oversea buyers through the medium of this trade newspaper, which enjoys a wide sale throughout the world.

Particulars and advertising rates will be gladly supplied to all interested by our European representative.

W. LIONEL STURDY

2 Gresham Buildings

Basinghall St., London, E. C.

companiment by himself; "The Witness" (Wick), George Robey.

Ten-inch single-sided: "My Memories" (Tosti), Hubert Eisdell, with Celeste and violin accompaniment; "The Fairy Pipers" (Brewer), Miss Evelyn Harding.

Twelve-inch double-sided: "Yankiana—American Suite—The Song of the Bells—Mighty America" and "Yankiana—American Suite—Arrival of the Coontown Cadets" (Thurban), band of H. M. Coldstream Guards; "Military Symphony"—"Allegro" and "Allegretto" (Haydn).

Ten-inch double-sided: "When Mr. Moon Is Shining," "Mam'selle Tralala" (Gilbert), and "My Little Persian Rose" (Friedland), Jacobs and his Trocadero Orchestra; "La Riterata"—Italian March (Drescher), and "March Namur," (Richards), Metropolitan Orchestra; "All Aboard for Dixieland"—Turkey Trot (Cobb), and "Ninetta"—One or Two-Step (Christiné), Metropolitan Orchestra; "Sympathy Waltz" (Friml), and "Who Paid the Rent for Mrs. Rip Van Winkle?" (Medley), Metropolitan Band.

American Business System Admired.

A splendid tribute was paid to the American trading system by Otto Heinemann, a director of Carl Lindstrom, Ltd., with whom your correspondent recently conversed in London. During his six weeks' visit to Canada and the United States Mr. Heinemann visited many talking machine trading centers with the object of studying at first hand the situation in connection with patents and trading prospects. With regard to the former he has formed certain conclusions which, I was informed, might be divulged at some future date. What interested him as much as anything was the amazing demand on your side for dancing records, the sale on which, while good, is by no means comparable in Europe. Passing to the great Victor and Columbia corporations, Mr. Heinemann paid tribute to the extensive ramifications of their wonderful business organizations, the successful handling of an enormous output distributed by picked agents in every center of your continent, effective selling and advertising plans, and withal,

(Continued on page 50.)



To T.M. the King and Queen of Spain



To H.M. the King of Sweden



To H.H. the Khedive of Egypt



To H.M. the King of Italy

"His Master's Voice"

—the trade-mark that is recognised throughout the world as the

Hall-mark of Quality

AUSTRIA: Oesterr. Grammophon-Gesellschaft, m. b. H., 8, Krugerstrasse, Vienna.
 BELGIUM: Cie. Française du Gramophone, 51, Avenue de la Porte de Hal, Brussels.
 DENMARK: Skandinavisk Grammophon-Aktieselskab, Frihavnens, Copenhagen.
 FRANCE: Cie. Française du Gramophone, 115 Boulevard Richard Lenoir, Place de la République, Paris.
 GERMANY: Deutsche Grammophon-Aktiengesellschaft, 35, Ritterstrasse, Berlin, 542.
 HOLLAND: American Import Co., 22a, Amsterd. Veerkade, The Hague.
 HUNGARY: The Gramophone Co., Ltd., IV, Kossuth Lajos-Utca 8, Budapest.
 SPAIN: Cia. Francesa del Gramophone, 56, Balmes, Barcelona.
 SWEDEN: Skandinaviska Grammophon-Aktiebolaget, 52, Appelbergsgatan, Stockholm.

RUSSIA: The Gramophone Co., Ltd., 45, Nevsky Prospect, St. Petersburg; 9, Golovinsky Prospect, Tiflis; 30, Novia Svit, Warsaw.
 EGYPT: The Gramophone Co., Ltd., 13, Rue Stamboul, Alexandria; Rue Mousky, Cairo.
 EAST AFRICA: Bayley & Co., 8 Beira, Lourenço Marques.
 SOUTH AFRICA: Darter & Sons, Adderley St, Cape Town; Mackay Bros., Rissik Street, Johannesburg; Mackay Bros. & McMahon, 443, West Street, Durban.
 Ivan H. Haaburger, Maitland St., Bloemfontein.
 INDIA: The Gramophone Co., Ltd., 139, Ballighatta Road, Calcutta; 7, Bell Lane, Fort, Bombay.
 AUSTRALIA: The Gramophone Co., Ltd., Hoffnungs Chambers, Pitt Street, Sydney.
 GREAT BRITAIN: The Gramophone Co., Ltd., 21, City Road, London, E.C.



To H.M. the Shah of Persia



By Appointment To H.M. Queen Alexandra

Great Britain:

The Gramophone Company Ltd
 21 City Road London EC



"MIRACLES HAPPEN EVERY DAY"



In the last issue of this journal we kind of proved it, so "nuff said"—BUT just take a note that we can supply Gramophones, made in such a way that all the trouble has been left out of them, at from \$2.50 each. We sold 20,000 at this price last year in this market alone.

As for Records—Needle Cut—10 inch double sided, made with the finest "stock" in the world—we can quote you prices f. o. b. London or otherwise, at your option—that no other firm—never mind how big they are—can approach. Try us and *write right now* for eye opener quotations.

BLUM & COMPANY, LIMITED

Manufacturers

Offices and Showrooms: 220 OLD STREET (Corner of City Road), LONDON, ENGLAND

Cables: Blumogram, London.

Codes: A. B. C., 4th Edition, Western Union, Reuters, Liebers.

Phones { 5048 } London Wall.
{ 5049 }

FROM OUR LONDON HEADQUARTERS—(Continued from page 49).

the maintenance of quality and prices, which latter, especially, half convinced him that there would be no great market for cheap Continental machines, the importation of which he found to be of negligible quantity. Speaking of Canadian conditions, my informant said the assembling of machines from parts bought abroad was very much on the increase. Mr. Heinemann is rather doubtful of German trade prospects after the war, and thinks that traders in British possessions will in future buy only British goods.

Famous Girl Tenor for Columbia.

The record that stands at the head of the Columbia Supplement for September will excite special interest, as it introduces to Columbia patrons the phenomenal girl tenor, Ruby Helder, who has recently added to the luster of her English reputation by a highly successful concert tour of Canada and the United States. Her unique voice is a genuine tenor of such quality, power and virility as would dignify any great star of opera. Two of the most characteristic and popular of tenor songs are combined on her first double record, namely, Tosti's "My Dreams" and Charles Marshall's delightful ballad, "Dear Love, Remember Me."

Old Songs in Demand.

The popularity of songs of the light operas of fifteen or twenty years ago is beyond question, and that there is apparently still a pronounced demand for vocal numbers from them is well shown by the special issue of a Columbia record this month of "Star of My Soul," from "The Geisha," and "The Shade of the Palm," from "Florodora," sung by Edgar Coyle.

Choice of "Aida" a Wise One.

The fact that "Aida" stands at the head of Covent Garden productions during the past season, with the largest number of performances, reflects strongly upon the wisdom of the Columbia in choosing that opera for the first of its complete series. We learn, too, that the Columbia Co. has sold a very large edition of its "Aida" set.

Receives Award of Merit for Columbia Exhibit.

The latest advices from New Zealand state that A. H. Nathan, Ltd., of Auckland, has received the official first-class award of merit for its exhibit of Columbia graphophones and Columbia records at the Auckland exhibition.

Two Popular Records.

"Harmony Bay," declared to be the successor to that great hit, "Moonlight Bay," is sung by the Peerless Quartet on Columbia Rena this month, in company with "I Want to Go Home," which is the latest song from the pen of the composer of "Robert E. Lee."

The Man of Many Parts.

To the uninitiated the above caption to this short article might be suggestive of matters theatrical, but let me at once assure my readers of the contrary. This descriptive title has been adopted by W. H. Reynolds, of 45 City road, London, as a trade slogan and is in every way appropriate to his business, which is to supply any and every part of various makes of gramophones. Mr. Reynolds may be pardoned a little haziness upon the subject, but he calculates roughly on having in stock over 1,000 different parts and accessories. All of which is preliminary to the fact that this firm has just issued its 1915 catalog, comprising no less than sixty-four pages, and plentifully illustrated throughout into the bargain.

COLONIAL and FOREIGN BUYERS

of gramophones and records may obtain valuable information from English firms who are desirous of opening up trading relations with oversea markets upon application, stating requirements, etc., to our European representative,

W. LIONEL STURDY

2 Gresham Buildings,

Basinghall St.,

London, E. C.

To review adequately this fine trade encyclopedic price list would require two or more pages of The World. It must suffice, therefore, to give brief mention of a selected number of the innumerable lines marketed by Mr. Reynolds.

Firstly, in regard to complete machines, there is itemized a wide range of exterior-horn, cabinet and hornless at prices from 12s. 6d. upward. An example of the exterior-horn type suitable for colonial and other buyers is the "Reno" model superbe, carrying the following specification: Large solid oak or mahogany French-polished cabinet, silent running double-spring Swiss fibre worm-governed motor, well-finished tone-arm, 12-inch turntable, 22-inch bell solid oak or mahogany horn, "Reno" Stentor sound-box, etc. This fine instrument represents really remarkable value and good all-round quality at the price, 42s.

One of the most amazingly cheap lines in cabinet manufactures ever offered to the trade here is the "Reno" Concert de Luxe at £3 19s. 6d. This is a well-finished instrument in either oak or mahogany, bow-fronted, size 44x18x19 inches over-all. It stands on cabriolle legs and is provided with a cupboard for records. The equipment includes best double-spring Swiss motor and other fittings of strength and durability. If a trader desires to make up his own special line of machines, there is obtainable from Mr. Reynolds all the separate parts, including exclusive designs for cases or cabinets.

Among the hundred and one items listed I observe various kinds of sound-boxes, tone-arms, motors, turntables, non-slip record mats, connectors for every make of machine, arm-rests, elbows, metal and wood trumpets, needles, needle-boxes, the different parts of sound-boxes, motors, etc., gaskets, diaphragms, springs, screws, albums, record-carrying cases, record envelopes and dozens of other parts and accessories too numerous to mention. Any bona fide trader may obtain a copy of this wonderful catalog upon application to W. H. Reynolds, Ltd., 45 City road, London, E. C.

(Patents Granted or Pending the World Over)



HOFFAY'S

"The World's Musical Instrument"

GRAMOPHONE

Read the *second* opinion of the able representative of this paper which appeared on page 70 of the issue of July 15.

SOON READY

J. HOFFAY

67 Egerton Gardens, South Kensington, London, England

FROM OUR LONDON HEADQUARTERS—(Continued from page 50).

Takes Over Whole Stock.

The whole stock of instruments and parts held by Harth & Dubb, this city, has been acquired by the Utility Trading Co., the recently appointed sole selling agent for the British-made Favorite records.

Attractive Record Carrying Cases.

Among the several lines of record-carrying cases on sale here we must commend to the attention of foreign and colonial buyers that marketed by the Utility Trading Co., of 21 Paper street, London, E. C. It is put up in both the 10-inch and 12-inch size, each capable of holding up to about twenty-five records. They are made of fibre with doubly protected corners, hard-wearing and strongly constructed, leather handles, three fastenings, lined with felt, the finish throughout being in every way good. These cases are also to be recommended as of British manufacture, and priced as they are at a competitive figure, will

certainly meet with a ready demand from the trade.

The "Winner" Record to the Fore.

An offer of special interest to colonial and foreign traders is made in the "Winner" announcement this month, and we feel sure it will meet with a ready response. England is at last "waking up" in more ways than one. She is determined to enjoy to the full the benefit of her own markets. In our own sphere of trade activity some evidence of this is found in the stronger representations of British houses in our ad columns this month. Not the least important of these is the all-British firm which trades as the Winner Record Co. It offers at competitive prices first-class records of home manufacture throughout by British labor and capital. The "Winner" 10-inch double record enjoys a very high reputation the world over for smooth surface, excellence of recording and general artistic talent, and we can confidently recommend it to all discriminating

buyers overseas. In the "Winner" batch of patriotic issues nothing will be found wanting, there being an abundant choice of the war songs so much in demand just now by all English-speaking peoples. All profits from the sale of these special records will be devoted to the Prince of Wales' National Fund—a splendid policy which will commend itself to all.

Securing Colonial and Foreign Trade.

Preliminary to this short article I think it only fair to say that my intention is not to revile either German goods or the peoples with which Great Britain is at war, but frankly to point out the trading possibilities for British firms now that our colonies and certain foreign countries find their chief source of gramophone supplies cut off. It is not so much a question of politics or causes as the effect thereof. There is approximately over

(Continued on page 52.)

FAVORITE RECORDS made in ENGLAND

Favorite Talking Machines—Favorite Needles
Favorite Albums—Favorite Carrying Cases

FAVORITE RECORDS in all LANGUAGES

ARE THE CHEAPEST AND BEST

Buy Them and You Will Increase Your Profits Note Our Special Patriotic Records

Write Today for Illustrated Catalogue, Lists and Advertising Matter

THE UTILITY TRADING COMPANY, 21 Paper Street LONDON, E.C.

Cables: UTILITRACO, LONDON

BRITISH PRODUCTS FOR OVERSEA MARKETS!!

BEKA RECORDS

10 inch Double 2/6 - - - - - 12 inch Double 3/6

BRITISH MADE BY BRITISH WORKMEN IN A BRITISH FACTORY

Well equipped laboratory and works at Hertford, Eng.

NOW READY

Large stock of European National Anthems, British Patriotic
Airs and Martial Music.

PROMPT DELIVERIES ASSURED

Lists, Terms of Trading, Etc., willingly sent by

O. RUHL, Ltd., 77 CITY ROAD, LONDON, ENGLAND

DISC MACHINES

The German market being closed, oversea buyers of disc instruments should communicate with us for particulars and prices of some good selling lines we have to offer for competitive trade. Of British-Swiss manufacture, these machines are obtainable in a variety of styles and designs, at all prices, and being of reliable construction and good tonal quality will command a ready sale in the Colonies and foreign countries.

FROM OUR LONDON HEADQUARTERS—(Continued from page 51).

£100,000 worth of trade to be done with Australia alone, of which in 1912 Germany enjoyed 25 per cent. This business is not going abegging. Those making special efforts to interest Australian buyers will secure it.

It would be fair to assume that Germany's total exports of complete machines, parts and accessories reach in value many hundreds of thousands of pounds per annum. Of this amount a large proportion is absorbed by England, but there remains for capture the whole of her business with oversea markets. The chief manufacturing countries able to fill the breach are Great Britain and America, and traders in both lands will enter the field in competition. We are assured of a keen fight, but on grounds of sentiment and, I think, ability to supply on a more favorable basis of price and terms, British firms should enjoy an advantage over our American friends. Be that as it may, there certainly exists a preference for dealing with the mother country, and colonial buyers would therefore welcome the fulfilment of their trade requirements from London. British houses,

however, must meet the situation with evidence of willingness to accommodate themselves to the special needs of colonial trade by the production of instruments which in design and construction are suitable for hot climates. If this important matter receives consideration it will produce confidence and mutual satisfaction. The classified imports of talking machine goods by Australasia are not yet available for 1913, but I have gone to some trouble in ascertaining the total imports by the Commonwealth of Australia during 1912, feeling assured the details given below will prove both useful and interesting to all gramophone firms proposing to grasp the commercial hands of colonial traders. The figures given cover imports of gramophones, phonographs, cases and records, but not horns. In value we find the imports total the round sum of £141,622, in the following proportions: New South Wales, £117,601; Victoria, £12,565; Queensland, £3,317; South Australia, £2,705; Western Australia, £4,604; Tasmania, £812, and Northern Territory, £18.

Dissecting still further the subjoined discloses

the individual contributions of each exporting country:

Country of dispatch.	Country of origin.
United Kingdom	£68,152
Canada	270
New Zealand	1,480
Straits Settlements	242
Other British countries	127
Belgium	151
France	307
Germany	21,760
Italy	1,111
Spain	400
Switzerland	1,263
United States	47,949
Other foreign countries	73

From the foregoing it will be seen that a substantial amount of trade is available for capture.

Thanks to the British navy, all trade routes are open, at least the risk of capture at sea by the one or two enemy warships prowling around is exceedingly remote. Freightage rates are a little above normal, not sufficient, though, to seriously affect shipment.

Colonial trade conditions remain good, being unaffected to any appreciable extent by the war. To British houses I can say no more than a final exhortation to go in and win!

'TIS A SAD, SAD STORY.

Told by the Gentle Stranger to a Talking Machine Man, Who Soon Realized That He Was Not the Only Expert in the Selling Game—The Story Is Something Like This.

"Sir," remarked the pale and unnerved stranger to the patient but condescending talking machine man, "I was once a proud autoist, even as you! To-day I am but a physical shadow of myself—a past that ever haunts me."

The other man began to hunt a half dollar.

"No, no," the stranger hastened on, "I want nothing but your sympathy—and the promise that you'll take warning. I began autoing with an ordinary, well-trained, city-broke, soft-toned horn. But this soon became too tame; I had a calliope attachment added. I made the welkin ring for awhile; then the people got so used to it they didn't get out of my way. Next I installed a rattler that sounded like an explosion in a boiler factory. But even that lasted but a few short weeks, as an efficient warning to the sleep-walkers who crossed my path. I—"

"Pardon me," protested the man he had tackled, "but I don't need an auto horn. You see—"

"—had to hook on a regular freight train screecher next," the stranger persisted. "It sounded as if the whole of No. 3, through freight, had streaked through town with its whistle cord tied down. Even the policemen stayed awake when I came by. But the gentle pedestrian got used to it, just the same, and at last—at last I was forced to equip my machine with a pair of ice tongs to lift 'em out of the way. I'd made everyone in my burg stone deaf with my auto warnings. And that brings me to the point. I have here a small appliance which will make any deaf man—"

But the other, with one jump, had cleared the fence and was gone.

TALKER BRINGS PEOPLE TO CHURCH.

(Special to The Talking Machine World.)

GREENCASTLE, IND., September 7.—The Claypool Music Co., of this city, successful and progressive Victor dealer, recently loaned a Victrola and records to the First Baptist Church to be used at a special concert that the church was presenting. The success of this division of the entertainment is well set forth in the following letter sent to the company by E. G. Shouse, the pastor, reading in part as follows: "The introduction of the Victrola into the Sunday evening services of my church proved to be a happy innovation and resulted in doubling the Sunday night attendance." Needless to say, the Claypool Music Co. has not hesitated to use this testimonial whenever it could accomplish beneficial results.

The fellow who is always on the fence must be pretty well balanced to stay there.

Where one man throws his whole soul into his work another man is satisfied to put his foot in it.

TRADE IS ACTIVE IN TEXAS.

(Special to The Talking Machine World.)

CORPUS CHRISTI, TEX., September 3.—Notwithstanding the European war has cut business in some lines, the talking machine business in this part of Texas is particularly good.

The Gunst Piano Co. reports a splendid Victor business notwithstanding the fact that farmers here are unable to get money for their cotton, as this county produces more cotton than any other in the State.

However, the dance fever is on here and the city has been full of dancing teachers for the last six months and exhibitions have been given in the stores which have brought the talking machine people in close connection with the members of the dancing set.

The talking machine department of Eilers House at Tacoma, Wash., has been taken over by the Tacoma Eilers Talking Machine Co. H. E. French is president, A. W. Erhart vice-president and C. O. Girard is secretary and treasurer, the directors being the officers, Hy. Eilers and M. C. Koster.

NAME PLATES

DECALCOMANIE

PROVE the value of the
WATERPROOF nameplate
GOLD BY
Walschner Music Co.
INDIANAPOLIS

WINNIPEG PIANO Co.
333 PORTAGE AVE.
WINNIPEG, MAN.

ROCK & DRUM
109-109th ST. BROOKLYN, N.Y.

Why not apply
a transfer
nameplate on
your talking
machine cabinets?

WRITE FOR SAMPLES
AND PRICES.
SKETCHES
FREE

GEO. A. SMITH & CO., INC.

74 CORTLANDT ST., N. Y.

I. DAVEGA, Jr.

125 WEST 125th STREET, NEW YORK

Victor Distributor

PROMPT AND ACCURATE SERVICE

DEALERS: Write for our Victor
Pennant. Sent with our compliments.

TRADE IMPROVING IN BALTIMORE.

Sales in All Lines Show Substantial Increase—
Stocks in Excellent Shape—Fink Talking
Machine Co. Opens Branch—News of Month.

(Special to The Talking Machine World.)

BALTIMORE, Md., September 8.—While there has been some falling off in sales conditions during the last month or so in the talking machine lines, dealers announce that they have every reason to look for a big fall and winter business. It was at first thought that buyers would be somewhat backward, but prospects are coming in rapidly and they are of the most encouraging nature.

Manager S. A. Dennison, of the local branch of the Columbia Graphophone Co., announces that business has picked up so recently and shown such encouragement that those sections covered by the local office will be opened up again in the next week or so, despite the war and thoroughly canvassed. It was at first thought that this would be useless until after Thanksgiving at least, but conditions demand that things start, at once with the result that the traveling sales force will be augmented and a big rush for trade started. Business locally with the Columbia line has been very good during the month.

Manager H. C. Roberts, of E. F. Droop & Sons Co., Victor and Edison dispensers, announces that he has one of the best and largest stocks his store has ever carried and declares that this has been made necessary by the fine lot of prospects on hand. He advises all Victor dealers to do as he has done and stock up before holiday trade sets in and catches them without the proper line of goods to satisfy buyers.

The Fink Talking Machine Co. finds it necessary to branch out with the Victor and Columbia lines and has opened a northern branch on Greenmount avenue near Thirty-first street. Joseph Fink, proprietor, will conduct this new store in connection with the present one at Charles and Fayette streets in the heart of the business section of the city.

The H. R. Eisenbrandt Sons report a nice August trade with the Victor line at their store on Howard street near Saratoga street. Both the instrument and record demands were very brisk, and indications are that these will prevail all through the fall.

The Sanders & Stayman Co., Inc., was also among the dealers who came out during August with a good lot of sales of machines and records of the Victor and Columbia lines. This firm, too, predicts good things for the fall business.

VICTOR RECORDS BY JOHN INCE.

According to the news columns of a prominent theatrical paper, the Victor Talking Machine Co. has arranged to produce records made by John Ince, the well-known actor and motion picture director allied with the interests of the Lubin Co. in Philadelphia. Mr. Ince, who has had a long career as an actor on the legitimate and motion picture stages, possesses a voice of exceptional eloquence and volume, and particularly adaptable for recording purposes. It is stated that his first records will include Mercutio's Queen Mab speech from "Romeo and Juliet," Marc Antony's immortal declamation and the curse from "Richelieu."

VICTOR

A complete line of Victor products, from the smallest repair part to the biggest model of machine. Every shipment made promptly.

EDISON

Cylinder goods, machines and records; full stocks and immediate deliveries. A good popular-priced line for most any territory.

Louis Buehn

Philadelphia

THE VICTOR ON THE WATER.

J. H. Becker, Jr., and E. F. Spankus, of the Hoeffler Piano Co., Milwaukee, Give Practical Demonstration of Victor's Entertaining Qualities When Placed on a Boat.

(Special to The Talking Machine World.)

MILWAUKEE, Wis., September 9.—Something entirely new in the way of outdoor Victor concerts was afforded Milwaukee citizens recently by J. H. Becker, Jr., manager of the Victor department of the Hoeffler Piano Co., and Harry Spankus, of the same department. Mr. Becker and E. F. Spankus, with the purpose of showing how appropriate the Baby Victrola is to furnish music on the water, carried one of these handy little Victrolas to Washington Park, where they rented a boat and gave an interesting concert on the park lagoon. All the August Victor records and some of the July numbers were featured, and a big audience soon crowded the banks of the lagoon to listen to the music. One man nearly fell in the water when Mr. Becker played Harry Lauder's "Laughing" record, No. 52,004. The concert was a big success and demonstrated in the best possible manner that Victor music on the water is delightful.

TO MOVE TO LARGER QUARTERS.

The Lucker Music House, St. Paul, Minn., handling talking machines and records, will move from its quarters on Seventh street to a much larger home in the new Raudenbush building at Sixth and St. Peter streets.

MOVIES FOR VICTOR EMPLOYES.

Six Thousand Employes of Victor Talking Machine Co. and Their Families See Films Showing Work in Every Department of Mammoth Plant at Private Exhibition.

(Special to The Talking Machine World.)

CAMDEN, N. J., August 30.—Thousands of employes of the Victor Talking Machine Co. filled the Plaza Theater here at two performances last week and immensely enjoyed a complete review of the process of making Victor talking machines and records. The company has 6,000 employes, and in order to enable each of them and an additional member of their family to see the Victor pictures it rented for this entire week the Plaza Theater, and by giving two shows nightly, one at 7 and the other at 9, it was possible for each of the many Victor employes to have two tickets. This meant that 12,000 in all saw the pictures in the twelve performances that followed.

The moving pictures, which were first shown at the convention of the National Association of Talking Machine Jobbers at Atlantic City last month, showed every department of the Victor plant in action, even to the interesting detail of taking impressions of the music and the singers' voices. The making of the records, the cabinets and every detail that enters into the completed Victrola were most interestingly illustrated in the moving pictures. There were seven reels of pictures, or about 6,500 feet of film, and the show was interesting throughout the nearly two hours of continuous movement of the film. The last reel showed the 6,000 Victor employes assembled outside the mammoth plant.

READY REFERENCE OF GENERAL SUPPLIES

DEALERS

Send for our "Trial Proposition" on the Regina Hexaphone—the latest and best paying popular priced coin-operated instrument for use in public places.



THE REGINA CO.

211 Marbridge Bldg., 34th St. and Broadway, New York City
Manufacturers of Regina Music Boxes; Reginaphones; Coin-operated Mandolin Orchestrions; Vacuum Cleaners and other specialties.

Mermod & Co.
505 Fifth Avenue New York

Manufacturers of
Talking Machine Supplies
Motors—Sapphire Points
Diamond Points a Specialty

Keep Your Record Stock with



Costs about \$2.00 for 250 records for 50 years
Send for 20-page catalog

THE SYRACUSE WIRE WORKS,
SYRACUSE NEW YORK



Our Foreign Record Department issues records in 33 different languages, including all the nations at war, and thousands of Columbia dealers in this country are making good regular money on these records.



(Write for "Music Money," a book "full of meat" for those dealers interested in quick and frequent turnover of capital.)

**Columbia Graphophone Company
Woolworth Building, New York**

GENERAL BRACING UP OF THE TRADE IN DETROIT.

Effects of War Scare Wears Off Quickly and Optimism Rules—New Columbia Dealers Announced—Claim Banks Have Overreached Themselves—Better Grades of Machines and Records Have the Call—Few Talking Machine Exhibitors at Michigan State Fair.

(Special to The Talking Machine World.)

DETROIT, MICH., September 10.—A month ago the talking machine dealers were having a little scare over the effects of the European war on business, but that has all passed now. S. E. Lind, city sales manager of the Columbia branch in Detroit, expressed the general sentiment pretty well when he said to The Talking Machine World representative:

"There has been a general bracing up in trade in the last three weeks, and in my opinion we are going to have one of the liveliest fall and winter seasons in the history of our business. I form this opinion from what I hear from our dealers in all parts of the city and from what we get from out in the State. These dealers form their opinions from what people say to them, from the requests for machines, from statements of people that they are in the market for machines, etc. Never were the prospects brighter.

"People have gotten over their little fright. The only adverse effect the war can have, if it has any, will be to throw some men out of work in lines of industry which depend a good deal upon exporting for their market. This, of course, would hurt some. But indications are that trade will be fully

resumed soon with all countries except Germany and Austria, and, in addition, that new markets will be developed in South America. So probably in a short time we will have larger export markets than we ever did.

"Out in the country the people are eager for next year. The farmers believe the war will make them rich, and they are preparing to raise bigger crops of wheat and other things that can be sold in Europe than they ever did in their lives. They already are selling their large crops of this summer, and with so much optimism for next year they are not at all backward about spending their money.

"That is the situation which, in my opinion, will make the fall and winter of 1914-1915 the greatest in the history of the phonograph trade. It is no more than I expected all through the summer. The war scare did not last a week, and the big business that was in sight is bound to come along."

The Columbia Co. has several new wholesale accounts lined up in the city and will make the first deliveries in September. "We could have opened them before this, but we do not care to sell to new dealers during the summer season, when it is apt to be a little dull," said Mr. Lind. "It might

discourage a man before he fairly gets started."

Later in the fall several new accounts will be opened in cities out in the State.

An unusual reason why people are willing to spend their money and are showing a marked confidence in the soundness of the business situation is being given by the talking machine dealers. They say that the banks have overreached themselves. Generally, when banks tighten up their credits, it causes a scare. That was what caused the temporary scare early in August. The banks are demanding ninety days' notice of withdrawal of savings deposits. It makes people angry. So when they obtain funds they decline to put them in savings banks. They keep their surplus money at home, so they can use it when they need it. And when they find they have quite a bit on hand, and happen to recollect that they have been intending to buy a talking machine or something else, they make up their minds they might as well buy it while they have the money handy. This, of course, stimulates business of all kinds, causes larger demand for merchandise and increases employment.

The trend of prices in the talking machine business continues upward. In the principal stores it is a rare thing for a customer to ask for a machine costing less than fifty dollars. The smaller ones are becoming unknown. One reason is that if a party knows his neighbor has a machine that cost fifty dollars he wants to own one that cost a little more and buys a seventy-five dollar one. Or if his neighbor has a hundred and fifty dollar style, he will get a two hundred dollar one for himself. As the largest of these accounts are safe ones, with good payments down, the dealers are much pleased at the rivalry.

September is State Fair month in Detroit, but the talking machine houses expect to get their share of the visiting trade without going to the fair. "If there were as many different kinds of talking machines manufactured as there are pianos it would be necessary for us to exhibit," said one dealer. "But with only three or four, and those well known, we had better stick to our stores. We will get just as much business without going to bother and expense of an exhibit at the fair."

Grinnell Bros. will have a few Victors in their general exhibit, however. As they have the space anyway for their pianos and other musical merchandise, there is no additional expense in the showing of talking machines. And it adds to the variety and attractiveness of the exhibit.

J. Henry Ling, of this city, has been investigating the merits of the Crescent talking machine.

NEW COLUMBIA AGENCY.

One of the latest additions to the fast-growing lists of Columbia representatives up-State is Marson Bros., Utica, N. Y., who has just closed arrangements to handle Columbia products with the intention of concentrating their activities on the development of foreign record and machine business. The present wars abroad have created an increased field for the sale of foreign records of various languages.

Special

Send for a package of our Improved Half-Tone and Loud Tone Needles in New Style Envelopes.

If you want to advertise yourself, we will put your own name or trade-mark on the envelopes, or will pack in Puritone envelopes.

Quality Guaranteed

The Best Needles mean profit and satisfaction.

If you want to sell 1,000 Needles at a time instead of 100, use the "Dean-packed" Needles. Five boxes of 200 each, Extra Loud, Loud, Opera, Medium and Soft packed in a carton. The best package and fastest seller on the market. Write for samples.

JOHN M. DEAN, CORP.

Talking Machine Needle Manufacturers

PUTNAM, CONN.

DEATH OF HORACE PETTIT.

Noted Attorney on Patent Law and Counsel for the Victor Co. Passes Away in His Fifty-fourth Year—Participated in Many Notable Cases in the Federal Courts.

(Special to The Talking Machine World.)

PHILADELPHIA, PA., September 5.—The death of Horace Pettit, the widely known corporation lawyer of this city, which occurred just after The World went to press last month, at his summer home in Ventnor, near Atlantic City, N. J., has caused sincere regret among those who were privileged to know this very distinguished authority on patent law.

Mr. Pettit had been for many years counsel for the Victor Talking Machine Co. and was engaged in many notable cases based upon patent rights and price maintenance, and always made a great impression on the Federal judges by his complete understanding of the law and the thoroughness with which he had prepared his cases. He also appeared at various times in Washington in opposition to bills presented in Congress inimical to the interests of the talking machine trade, and he was always listened to with the respect due an authority. In fact, there were few men who had such a thorough grasp on the basic patents underlying the talking machine industry as the deceased.

Mr. Pettit, who was fifty-four years old, had been ill for some time, but few considered his indisposition would result fatally. He was a member of the Union League, Racquet, University, Art, Huntington Valley, Country and Bachelors' Boat clubs. He is survived by a widow and one son.

REMODELING WORK COMPLETED.

In the Warerooms of the New York Talking Machine Co. Following Recent Damage by Fire—New Demonstrating Booths.

The various improvements incidental to the renovating of the warerooms of the New York Talking Machine Co., 81 Chambers street, New York, Victor distributor, have been entirely completed, and the store now presents a decidedly more attractive appearance than it did before the warerooms were practically destroyed by fire on June 21. One of the improvements consists of the construction of two all-glass demonstration rooms for the display of machines, and the company's dealers are now enabled to have demonstrated all the machines on display with maximum convenience.

PLANS FOR NEW DINING ROOM.

Architects are now preparing plans for a large two-story dining room building as an addition to the plant of the Victor Talking Machine Co., Camden, N. J.

PRINCIPLES UNDERLYING "COPY."

Interesting Discussion by Felix Orman on Different Appeals Made by Advertising—Points Out the Far-Reaching Results of National Campaign of Victor Talking Machine Co.

Under the heading "What Are the Principles Underlying Your Copy Appeal?" Felix Orman, writing in Printers' Ink, recently called attention to a number of national advertising campaigns which have for their purpose far more than a mere attempt to secure business and boom individual trade.

Referring to the immense and far-reaching campaign of the Victor Talking Machine Co. in magazines and newspapers, Mr. Orman remarks as follows:

"A volume might be written alone on the subject of what the advertising of the talking machine has done in developing the love of music in America. The message of the talking machine has reached the remotest sections of the country and this machine has been shipped to people with little knowledge of the charm of sound who became music enthusiasts. Talking machine advertising indeed has made this a musical nation. John Burroughs, the naturalist, lived for years among his trees and shrubs without knowing anything of music. Then he bought a Victrola. He would sit for hours listening to the strains of Sousa's orchestra, or the voice of Tetrassini or the shouting of a ragtime singer. His life was made fuller and happier by this instrument. A caller criticized him for what the visitor called an 'unfortunate musical taste,' but the distinguished naturalist was quick to rebuke his critic with a statement of what the talking machine had done in teaching the masses to love music, which, he said, as we all know, meant the softening of the nature of the people and the development of their tenderer sensibilities.

"There is no denying," said Harry Brown, advertising manager for the Victor Talking Machine Co., 'that the talking machine has had a tremendous value in advancing our national life. Thousands of people—and many thousands of them—now love music who never had any patience with it before the talking machine carried it to them in a way that held their interest. Now those same people are developing a fine musical taste. More people hear Caruso's voice from Victor records every day than heard Patti in her entire operatic career. We have striven for this effect in our advertising, and we are gratified at the splendid educational and refining influence that our advertising has exerted."

SEE HOW THE JOBBERS IN THE WORLD CAN SUPPLY YOUR WANTS.

TALKING MACHINE EXPORTS.

The Figures for June Presented—Exports Show Falling Off for the Month.

(Special to The Talking Machine World.)

WASHINGTON, D. C., August 31.—In the summary of the exports and imports of the commerce of the United States for the month of June (the latest period for which it has been compiled), which has just been issued by the Bureau of Statistics of the Department of Commerce and Labor, the following interesting figures relating to talking machines and supplies are set forth:

The total exports of talking machines, records and supplies for June, 1914, amounted to \$162,303, as compared with \$216,478 for the same month of 1913.

POPULAR LINE OF RECORD ALBUMS

That Manufactured by the National Publishing Co., Philadelphia—Have a Number of Interesting and Valuable Features—Special Circular Service for the Retailer.

(Special to The Talking Machine World.)

PHILADELPHIA, PA., September 8.—The National Publishing Co., the well-known maker of disc record albums in this city, report that the demand for their products from the trade throughout the country is increasing steadily as the jobbers and dealers realize the excellent and salable features of the albums.

The National Co.'s albums are designed for both ten-inch and twelve-inch records, and with ten or seventeen pockets, according to size desired. Each of the albums is supplied with envelopes of heavy manila paper of extra quality and bound with heavy bookbinders' boards covered with brown silk finish cloth. Two index pages, especially designed to list double sided records are also included with each album, and this index, taken in connection with the fact that the record labels may be read through special openings in the sides of the pockets, make the finding of desired records particularly easy.

The albums are also designed to fit perfectly the new types of machine cabinets and the leading styles of separate cabinets, which fact adds materially to their salable qualities.

The National Publishing Co. has also created an excellent system for co-operating with the jobber and dealer in advertising and pushing the albums made by the company by offering to supply, without charge, special circulars for the retail trade in quantities of 500 or more. The circulars contain illustrations, descriptions and prices of the albums, and also bear the name of the dealer or jobber to whom they are supplied. An excellent idea.

An Added Line That Will Make You Money



The H. P. Nelson Small Grand

The talking machine dealer can carry a small stock of pianos to the greatest advantage because he is the possessor of certain natural facilities that, of themselves, bring him sales.

The profits on a piano sale are large. The expense of carrying a few instruments is almost negligible, and their sales come oftener than you, perhaps, think.

Our line of uprights, players and grands is especially adaptable to the wants of the talking machine dealer who to a certain extent relies upon the instrument to sell itself. We have built up a tremendous business upon our policy of giving the greatest return for the least money, and the value of our products is so apparent that even those least acquainted with pianos are instantly aware of their worth.

Get our special proposition to you

H. P. NELSON COMPANY 816 N. KEDZIE AVENUE
CHICAGO

LATEST PATENTS RELATING TO TALKING MACHINES AND RECORDS

(Special to The Talking Machine World.)

WASHINGTON, D. C., September 10.—SOUND BOX. George Lansing Funnell, London, Eng., assignor to the American Graphophone Co., Bridgeport, Conn. Patent No. 1,104,182.

This invention has for its object to produce a sound box, in which the diaphragm casing proper shall be yieldingly connected to its support, such as the hub or neck of the sound box, the union being effected through the medium of a resilient joint which leaves the diaphragm casing free to have a limited movement with relation to the hub or neck.

In reproducing from certain sound records of the zig-zag type, and particularly those records of sounds having great amplitude of vibration, it is a recognized fact in the art that the strain upon the diaphragm is decreased, and the pleasing character, quality and definition of the reproduced sounds is much enhanced by providing a yielding connection between the sound box casing and its support, the yielding connection being preferably situated at the joint between the casing and the neck or hub of the sound box.

The object of the present invention is to provide an improved form of yielding resilient joint between the sound box and its support, thereby obviating the production of a harsh metallic sound by the instrument and improving the reproduction as to volume, tone, quality and definition.

The objects of the invention are accomplished, in the present instance, by forming the diaphragm

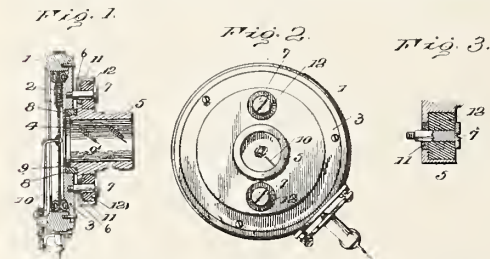

casing preferably metal, with the diaphragm mounted therein in any suitable manner, and preferably the back of the casing is closed by a metal plate having a central opening therethrough, and the hollow hub or neck is secured to this metal back by any suitable means, such as screws located on a line passing diametrically through the hub. To effect this the hub is provided with a flange and the screws are passed through the flange and into the metal back of the diaphragm casing, and there is interposed between the hub and the back of the casing a narrow ring of any suitable resilient material, such as rubber, the thickness of the ring being such as to prevent the flange of the hub from contacting with the back of the casing, the ring serving to form a yielding, resilient connection between the casing and the hub. As thus constructed the diaphragm casing is free to rock on the resilient ring without imparting corresponding motion to the hub vibrations imparted to the casing are not transmitted to the hub, and vice versa, and at the same time a complete closure is formed at the joint between the hub and the casing.

In the drawings Fig. 1 is a central sectional view illustrating one form of this invention; Fig. 2 is a side elevation thereof; and Fig. 3 is a detail.

PHONOGRAPH SOUNDING-BOARD. Donald M. Bliss, Orange, N. J., assignor to the Bliss Talking Machine Co., Delaware, Md. Patent No. 1,104,340.

The objects of this invention are: 1. To provide vibratory members and sounding board members for all acoustical devices, having the maximum of resilience, lightness and stiffness, and also to incorporate these members in phonographs. 2. To combine a vibratory resonator attached to a stylus mounting with a turntable provided with a resonating chamber of resonant material. 3. To provide improved construction for other associated acoustical and mechanical devices, as will appear more fully from the following detailed description

and claims, and to provide a window in a sounding board or resonator.

The advantages of the invention are that these acoustical devices will give improved results, and when incorporated in phonographs together with the associated devices, the phonographs will play either lateral or vertical cut records; have a low cost of manufacture; require no moving parts intermediate the stylus and sounding board; be compact, and also be convenient to operate.

Referring to the accompanying drawings, Fig. 1 is a plan view of the phonograph, containing sound-

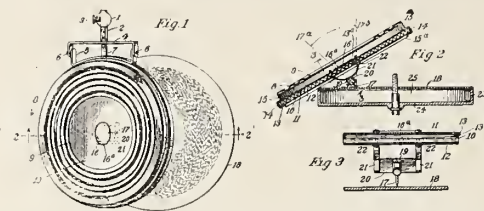

ing board or sounding board diaphragm. Fig. 2 is a partial sectional side elevation of the device of Fig. 1, taken on the line 2-2, looking in the direction of the arrows. Fig. 3 is a partial cross section of the device of Fig. 2, taken on the line 3-3, looking in the direction of the arrows.

STYLUS FOR SOUND-REPRODUCING MACHINES. Gustave Lehr, New York. Patent No. 1,103,592.

The object of this invention is to furnish for sound-reproducing machines a stylus which is durable in use, not prohibitive in cost, and which yields a superior tone. These objects are attained by making the record-engaging portion of the styli of ruby, and forming the same in generally pyramidal form with a curved face.

In the accompanying drawing Fig. 1 is a side view of a portion of a gramophone disc, and a front view of the reproducer of the instrument, showing in position of use a stylus embodying the invention. Fig. 2 is an enlarged side elevation of the stylus removed from the machine. Fig. 3 is a view on a similar enlarged scale, taken from the

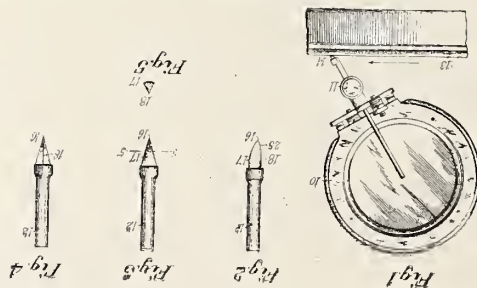

rear of the stylus. Fig. 4 is a front elevation on the same enlarged scale. Fig. 5 is a horizontal section on line 5-5 of Fig. 3 through the jewel forming the working point of the stylus.

GRAMOPHONE NEEDLE OR STYLUS. Minard A. Possons, Cleveland, O. Patent No. 1,103,829.

This invention relates to improvements in gramophone needle or stylus, and the object is to provide a needle or stylus for a gramophone which

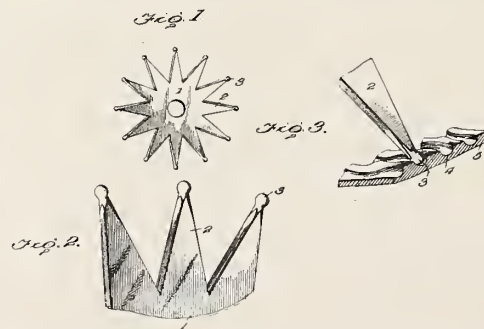

can be made of a very thin sheet of metal and yet have the stability to support the reproducer.

Another object is to provide a needle of this character in which the thickening of the supporting point not only strengthens the needle for support-

ing the reproducer, but also forms a round surface adapted to fill the sound grooves of the records which does away with the grinding sound usually caused by the ordinary pointed needle or stylus and also prevents any injury to the record.

A still further object of this invention is to provide a needle of cheaper construction in that there is a great saving of material and at the same time having the necessary strength and flexibility.

In the accompanying drawing Fig. 1 is a perspective view of a star needle embodying the invention. Fig. 2 is an enlarged perspective view of a portion of the star showing more fully the rounded elliptical members carried by the ends of the points of the star. Fig. 3 is a vertical enlarged sectional view of a record showing the needle in perspective in its position in the sound grooves.

COMPOSITE DISC SOUND-RECORD. Victor H. Emerson, New York; Geo. A. Manwaring, Bayonne, N. J., and James K. Reynard, New York, assignors to the American Graphophone Co., Bridgeport, Conn. Patent No. 1,102,253.

This invention relates to sound-records impressed in discs or tablets, and more particularly to the composite tablet and the manner of building up the same and the method of making the record.

The invention will best be understood by describing in detail the successive steps employed in producing the article.

Fig. 1 shows a pair of rollers through which is

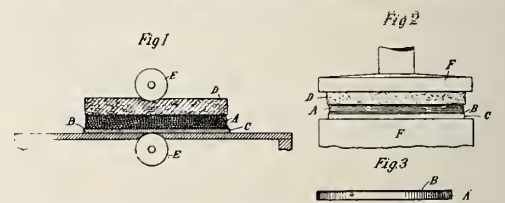

passing a matrix and the unfinished record tablet; Fig. 2 represents a press operating upon the same, and Fig. 3 is the finished article.

REPRODUCER FOR PHONOGRAPHS. Simon D. Paddock, New York. Patent No. 1,102,290.

This invention pertains to reproducers for phonographs, and relates, more particularly, to improvements whereby the diaphragm is maintained in such operative state as to insure at all times its most efficient action in quickly and perfectly responding to the movements of the stylus as it traverses the record.

Speaking generally, the improvement consists in so balancing the stylus or tone bar that the diaphragm is free to quickly and accurately respond to the most minute movements of the stylus. This result is accomplished by associating with the stylus

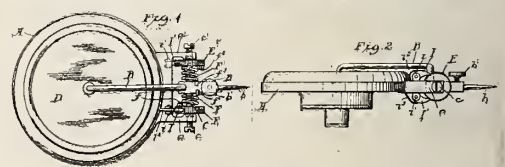

bar and its supporting spindle two complementary springs, one of which exerts tension on the stylus bar and thus applies pressure to the diaphragm in one direction, while the other exerts an opposed tension on the stylus bar and a consequent pressure on the diaphragm in an opposite direction to that produced by the first spring. In the preferred construction suitable means is provided for varying the tension on the said springs, and it will thus be obvious that they can be so adjusted that the diaphragm is placed under such tension as to produce sounds of the purest and best quality, and yet be so sensitive as to reproduce the most delicate and softest tones.

Fig. 1 is a plan view of a phonograph reproducer embodying the present invention, and Fig. 2 is a side elevation thereof.

SOUND PRODUCING DEVICE. Harry Alfred Gaydon, Croydon, England. Patent No. 1,102,260.

This invention relates to sound producers of the kind in which a valve, consisting of a comb or grating, the teeth or bars of which are adapted to close the spaces between the teeth or bars of a like comb or grating forming the valve seat, controls passages of elastic fluid thus producing the sound. In sound producers of this kind the valve has been

LATEST PATENTS RELATING TO TALKING MACHINES—(Continued from page 56).

carried by a torsional spring support mounted at each end in bearings arranged upon the valve seat so as to be adjustable, whereby the distance of the valve from its seat may be varied. Thus the torsional spring constitutes the fulcrum of the lever consisting of the valve and the piece that holds the stylus.

By this invention a lighter torsional spring is used by providing a separate fulcrum for the lever system comprising the valve. For this purpose the piece that holds the stylus is provided with a shoulder to which the torsional spring is fixed and takes under the block in which the valve seat is mounted; between this block and the shoulder are one or more balls or projections which serve as the said fulcrum. This construction allows of the ends

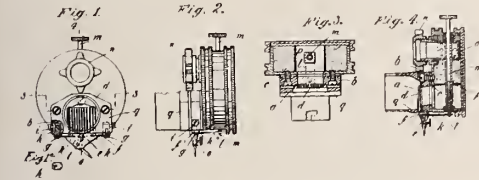

of the torsional spring being mounted in pieces adjustable on the under surface of the block carrying the valve seat, thus affording a more readily accessible adjustment than that afforded when the bearings of the spring are carried on the face of the valve seat. It also provides greater flexibility in the desired direction. This construction of the piece that holds the stylus also allows of a very simple adjustment of the spring pressure on the valve which balances the elastic fluid pressure. For this purpose one end of a blade spring may be fixed to the aforesaid shoulder, and the other end may be engaged by a screw spindle extending through the sound box. Another improvement is connected with the distribution of the elastic fluid entering the sound box. For improving this distribution the box is partitioned with wire gauze or the like, so that there is an inner compartment on the end wall of which the valve seat is situated, and an outer compartment surrounding or substantially co-axial with the inner compartment, and packed with cotton-wool or other suitable filtering material.

The accompanying drawings illustrate the invention as applied to the sound producer of a gramophone, Fig. 1 being a front elevation partly in section. Fig. 1a is a detail end view of one of the rotatable elements h. Fig. 2 a side elevation, and Figs. 3 and 4 sections on line 3-3 and 4-4, respectively, of Fig. 1.

SOUND-REPRODUCING DIAPHRAGM. Simon D. Paddock, New York. Patent No. 1,102,291.

This invention pertains to sound producing diaphragms, particularly adapted for use in phonographs, and embodies the diaphragm as a new article of manufacture.

The object of the invention is the production of a diaphragm which emits clear, pure and resonant tones, in contradistinction to the diaphragms now in use which produce tones of a more or less raspy or metallic character.

With the foregoing object in view, the invention embodies a suitable base member, preferably blot-

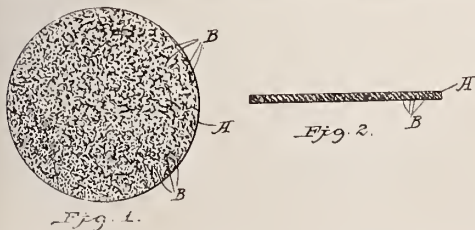

ting paper, which has been rendered hard and given vibratory qualities by means of a certain chemical treatment. The inventor says:

"The following detailed description of the manner of making the diaphragm is what I now consider the best method, but it will be understood that this is not the exclusive one, for, in all probability, other agents, more or less equivalent to those specified, may be employed to secure some or all of the advantages of my invention.

"I preferably start with a piece of blotting paper of the desired size, and dip it in a suitable volatil-

agent or menstruum, preferably ordinary ether, although I may use, though not with the same advantage, alcohol and benzol. The blotting paper having been treated as described, I immerse it, while saturated with the solvent, in a molten mixture consisting, preferably, of Japan wax, resin and fish glue. The proportions of the ingredients entering into this mixture may be varied within considerable limits, but the proportions, by weight, which I have found to give the best results, are substantially as follows: Japan wax, 20 per cent., resin 60 per cent., fish glue 20 per cent. The ingredients are mixed together and simply heated, preferably over a water bath, to a sufficient degree to melt them and produce a homogeneous mixture. The blotting paper, or other base material for the diaphragm, having been immersed in the mixture, is withdrawn and allowed to cool, whereupon there results a hard, waterproof, sonorous disc, particularly adapted for the purposes specified."

Fig. 1 is a face view of the diaphragm embodying the invention, and Fig. 2 is a cross section through the center thereof.

SOUND REPRODUCING AND RECORDING INSTRUMENT. Henry George Wieder, London, England. Patent No. 1,102,839.

This invention relates to improvements in sound

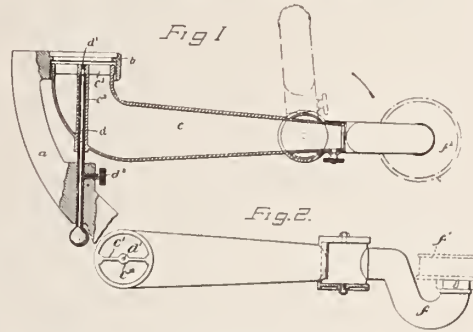

reproducing and recording instruments such as gramophones, phonographs and the like. One object of the invention is an improved means of attachment for the arm carrying the sound box or reproducer by which the arm is adjustable more or less vertically while it is carried in such a way that it can swing with a minimum of friction to the movement of the needle or sapphire upon the record.

The accompanying drawings are illustrative of an improved means of attaching the tone arm to its bracket, Fig. 1 being a longitudinal section and Fig. 2 a plan view showing the improved method of attachment as applied to a tone arm which is disposed beneath the trumpet.

PROCESS OF MAKING DUPLICATE PHONOGRAPH RECORDS. Jonas W. Aylsworth, East Orange, N. J., assignor to New Jersey Patent Co., West Orange, N. J. Patent No. 1,101,827.

This invention relates to a process for making phonograph records in which the wearing surface is entirely of metal. This material may constitute the entire record or may be a shell provided with a backing of other material.

The process is particularly adapted to the manufacture of cylindrical phonograph records, although it may be used for making records of the disc type, if desired.

Cylindrical sound records at the present time are generally made of a waxlike material molded or cast within a hollow matrix, and disc records are formed of somewhat harder material, employing considerable quantities of shellac, the impression being secured from a flat matrix. With both types of record the material is subjected to considerable wear when used in a phonograph or talking machine, and such wear becomes objectionably great when the width of the record groove is decreased beyond a certain point or when the pressure of the stylus upon the record is increased beyond a certain point. It has also been proposed to use for cylindrical records a material harder than the waxlike material just referred to, for instance, celluloid. Such records, however, are generally found to be of poorer quality as regards sound reproduction than those of waxlike material, and they appear to deteriorate with time. Moreover, a cel-

luloid record is also subjected to objectionable wear when the width of the record groove is diminished or the pressure of the stylus increased beyond a certain limit. It has also been proposed to make duplicate phonograph records in metal, but such processes have been objectionable in that it has been necessary to destroy the matrix in order to liberate the metallic duplicate.

By the present invention it is possible to readily free the metallic duplicate from the matrix without

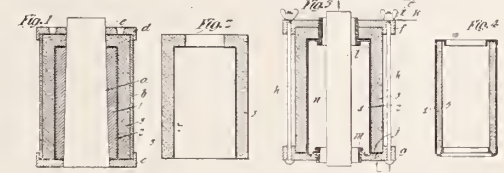

injury to the latter whereby the same may be used for the production of an indefinite number of copies.

Fig. 1 is a central vertical section of apparatus for producing the matrix within which the metallic records are to be deposited; Fig. 2 is a similar view of the matrix after being removed from the mold of Fig. 1, and after the master has been removed therefrom; Fig. 3 is a similar view showing apparatus for producing a metal deposit within the matrix to form the record or record wearing surface, and Fig. 4 is a similar view of the completed record in its preferred form.

GRAPHOPHONE RECORD-CLEANER. Walter Guy Pearson, Newburyport, Mass. Patent No. 1,102,073.

This invention comprises a new and improved cleaner for graphophone records, the construction and arrangement being such that records may be cleaned thoroughly and in a short time, the device being inexpensive in its make-up whereby it may be offered at a low price.

The provision of a device which may be easily manipulated is of some importance in setting forth the invention herein described, such ease of manipulation not being obtained at the expense of efficiency or thoroughness.

Fig. 1 is a plan view of one form of the device; Fig. 2 is a sectional view thereof along the line

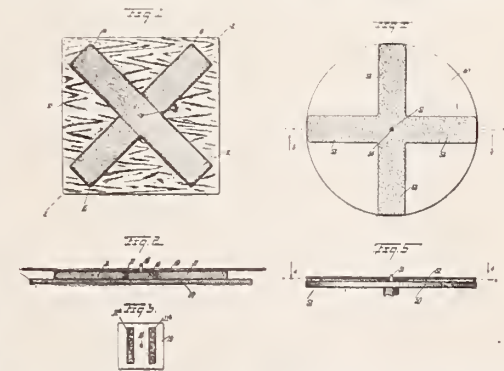

2-2 of Fig. 1, the record being shown in position for cleaning; Fig. 3 is a plan view of a modified form.

Fig. 4 is a top plan view of a graphophone turn table fitted with this device, on the line 4-4 of Fig. 5; Fig. 5 is a sectional view of the record and cleaning device on the line 5-5 of Fig. 4.

60 YEARS' EXPERIENCE

PATENTS

TRADE MARKS
DESIGNS
COPYRIGHTS & C.

Anyone sending a sketch and description may quickly ascertain our opinion free whether an invention is probably patentable. Communications strictly confidential. HANDBOOK on Patents sent free. Oldest agency for securing patents. Patents taken through Munn & Co. receive special notice, without charge, in the

Scientific American.

A handsomely illustrated weekly. Largest circulation of any scientific journal. Terms, \$3 a year; four months, \$1. Sold by all newsdealers.

MUNN & Co., 361 Broadway, New York
Branch Office, 626 F St., Washington, D. C.

RECORD BULLETINS FOR OCTOBER, 1914.

COLUMBIA GRAPHOPHONE CO.

SYMPHONY DOUBLE-DISC RECORDS.

No.	Description	Size.
A1570	I see Gwine Back to Dixie (White). Baritone Solo in English, orch. accomp. Oscar Seagle	10
A1575	Samson and Delilah (Saint-Saëns). "Israel burst your bonds." Tenor Solo in English, orch. accomp. Morgan Kingston	10
A5587	Aida (Verdi). "O Ciel! Azzurri" (O skies of blue). Spornano Solo in Italian, orch. accomp. Emmy Destinn	12
A5588	Melody in F (Rubinstein). Violin Solo, orch. accomp. Kathleen Parlow	12
A1569	Cherry Ripe (Horne). Soprano Solo, orch. accomp. Thamzene Cox	10
A1571	Lia ika Wai Mapuna (A Lonely Spring). Toots Paka Hawaiian Company	10
A1574	The Red and the Blue (Goekel). University of Pennsylvania Quartet	10
A1566	The Broken Hearted Sparrow (Bendix). Prince's Orchestra	10
A1567	Sunshine and Rain (Blumenthal). Contralto Solo	10
A1568	Unrequited Love (Lincke). Waltz, accordeon accomp. Guido Deiro	10
A1572	Lead Kindly Light. Concertina Solo. Alex. Prince	10
A5585	Romance (Svendsen). Violin Solo, with string quartet accomp. George Stehl	12
A5586	Douglas! Tender and True (Scott). Contralto Solo, harp and violin accomp. Mrs. A. Stewart Holt	12
A1578	My Croony Melody (Goetz and Goodwin). Baritone and Tenor Duet, orch. accomp. Arthur Collins and Byron G. Harlan	10
A1580	Giddy-up Maria (Bennett). Baritone and Tenor Duet, orch. accomp. Billy Watkins	10
A1581	Keep Your Eyes an Uncle Sammy (Greenberg). Orch. accomp. Peerless Quartet	10
A1577	Dear Love Days (Esrom). Lyric Trio, orch. accomp. Will Oakland, Henry Burr and Albert Campbell	10
A1579	In the Palace of Dreams (Friedman). Orch. accomp. Peerless Quartet	10
A1576	I Wonder Why (Friedman). Soprano and Tenor Duet, orch. accomp. Ada Jones and Henry Burr	10

DANCE RECORDS.

Recorded Under Supervision of G. Heppburn Wilson.

A5589	At the Ball (Hill). One-step. Prince's Band	12
A5590	Beautiful Roses (Friedland). Waltz-Hesitation. Prince's Band	12
A5591	Society's Waltz Trot (Platzmann). Prince's Band	12
A5592	Valse Classique (Adaptation of Dvorak's "Humoreske") (Arranged by Dabney). Prince's Band	12
A5593	Lulu Fado (Milano). Prince's Band	12

THOS. A. EDISON.

CONCERT LIST.

28200	Lolita—Spanish Serenade (Buzzi-Peccacia) Tenor Solo, orch. accomp. Redferne Hollinshead
28201	Parted (Tosti) Tenor Solo, orch. accomp. Redferne Hollinshead
28202	Just for To-day (Bingham) Contralto Solo, orch. accomp. Christine Miller

28203	Trovatore—Home to Our Mountains (Verdi) Contralto and Tenor Duet, orch. accomp. Margaret Keyes and Dan Beddoe
2415	Royal Australian Navy March (Lithgow). New York Military Band
2416	Ma Pickaninny Babe (Johnson) Counter-tenor Solo, orch. accomp. Will Oakland
2417	Favorite Airs from "Beggar Student" (Müllöcker) orch. accomp. Edison Light Opera Co.
2418	The Lover and the Bird (Guglielmo) Soprano Solo, orch. accomp. Mary Carson
2419	Mother Machree (Olcott and Bal) Violin, harp accomp. Charles D'Almaine
2420	Trust and Obey (Towner) Sacred Solo, organ accomp. Edison Mixed Quartet
2421	Scène de Ballet (Czibulka) Reed only. Edison Concert Band
2422	When It's Moonlight on the Alamo (Fischer) Tenor Duet, orch. accomp. Albert H. Campbell and Irving Gillette
2423	Valse June—Hesitation or Boston (Baxter) For Dancing. National Promenade Band
2424	Christ, My All (Main) Sacred Solo, orch. accomp. John Young and Frederick J. Wheeler
2425	You're More Than the World to Me (Solman) Tenor Solo, orch. accomp. Manuel Romain
2426	Beautiful Robes (Kirkpatrick) Sacred Solo, orch. accomp. John Young and Frederick J. Wheeler
2427	Wedding of the Winds Waltz (Hall). American Standard Orchestra
2428	When the Angelus is Ringing (Grant) Tenor Solo and Chorus, orch. accomp. Irving Gillette and Chorus
2429	Jimmy Trigger's Return from Mexico. Vaudeville Sketch. Billy Golden and Joe Hughes
2430	The Robin and the Wren (Banta) Vaudeville sketch. Byron G. Harlan and Joe Belmont
2431	Castles' Half and Half (Europe and Dabney) For dancing. National Promenade Band
2432	Tramp! Tramp! Tramp! (Root) Male voices, orch. accomp. Knickerbocker Quartet
2433	Romance from "L'Eclair" (Halévy) Zither Solo. Kitty Berger
2434	Mignon—Polonaise (Thomas). Whistling Solo. Guido Gialdini
2435	Too Much Ginger One-Step (Daly) For Dancing. National Promenade Band
2436	Basket of Roses (Albers Bells, orch. accomp. Charles Daab
2440	Beyond the Smiling and the Weeping (Geo. C. Stebbins) Sacred Solo, organ accomp. Peerless Quartet
2441	Kamenoi Ostrow (Rubenstein). American Standard Orchestra
2442	Zampa Overture (Herold). Edison Concert Band
2444	The Post in the Forest (v. Schäfer). Cornet and French horns. G. F. Heim and Waldhorn Quartet

Nov. 2437, 2438, 2439 and 2443 will be included in the November list.

VICTOR TALKING MACHINE CO.

No.	Description	Size.
17617	Rose of the Mountain Trail Medley—One-step. Victor Military Band	10
17619	The Memphis Blues—One-step (W. C. Handy). Victor Military Band	10
17626	At the Ball That's All Medley—One-step. Victor Military Band	10
17627	Lu Lu Fado—Le Vraj Fado Portugais (Nicolino Milano) (Patrick Conway, Director). Conway's Band	10
17628	La Vraie—Polka Bresilienne (P. J. de O. Pinto) (Patrick Conway, Director). Conway's Band	10
35390	Evening Dream—Waltz Hesitation. (Réve D'un Soir) (A. Nilson Fysher). Victor Military Band	12
17603	Good-Night Harvard March (D. S. Moore). United States Marine Band	10
17614	Over the Alpine Mountains (Alfred Bryan-Fred Fischer). Albert Campbell-Henry Burr	10
17613	California and You. (E. Leslie-H. Puck). Irving Kaufman	10
17620	The Aba Daba Honey-moon (Arthur Fields-Walter Donovan). Collins and Harlan	10
17621	Ev'ry Road Is the Right Road (When the Right Little Girl Is Along) from "The Elopers" (F. Herendeen-Hugo Frey). Harry Macdonough	10
17622	The High Cost of Loving (Al Bryan-Geo. W. Meyer). Peerless Quartet	10
17609	Hungarian Rag (Julius Lenzberg) (Accordeon) Pietro Deiro	10
17612	The Servant Girl (Golden-Hughes). Golden and Hughes	10

17618	Rose of My Heart (Eardley-Wilmot-Löhr). Reinald Werrenrath	10
17564	One Sweetly Solemn Thought (Carey-Ambrose). Elsie Baker	10
35353	Bohème—Selection (Puccini). Vessella's Italian Band	12
35386	Gems from "Pinafore"—Part I (Gilbert-Sullivan). Victor Light Opera Co.	12
60122	Mikado—Yum Yum's Song, "The Moon and I" (Gilbert-Sullivan) Soprano Solo. Rosario Bourdon	10
70108	Ta Ta, My Bonnie Maggie Darling (Lauder-Grafton). Harry Lauder	12
60123	Can's You Hear Me Callin' (Caroline Caro Roma Baritone Solo. George MacFarlane	10
88502	La Forza del Destino—Pace, mio Dio! (Mercy, O My Lord!) (Act V.) (Verdi) Soprano Solo in Italian. Luisa Tetrizzini	12
88488	Tannhäuser — Elisabeth's Gebet (Elizabeth's Prayer) (Act III) (Wagner) Soprano Solo in German. Emmy Destinn	12
74404	Beloved, It Is Morn (Emily Hickey-Florence Aylward) Tenor Solo. Evan Williams	12
88495	Oberon-Ocean! Du Ungeheuer! (Ocean, Thou Mighty Monster!) (Part I) (Weber) Soprano Solo in German. Johanna Gadsdi	12
87512	Bohème—O Soave fauciulla (Thou Sweetest Maiden) (Puccini) Soprano and Tenor Duet in Italian. Lucrezia Bori and John McCormack	10
87169	Sérénade Espagnole (Spanish Sérénade) (Ed. Teschemacher-Landon Ronald) Tenor Solo in French. Enrico Caruso	10
87204	I Cannot Sing the Old Songs (Claribel) Contralto Solo. Louise Homer	10
88471	Traviata—Ah, fors' è lui (The One of Whom I Dreamed) (Act I) (Verdi) Soprano Solo in Italian. Frieda Hempel	12
64408	Austrian Hymn (Arr. by Kreisler) (Haydn) Violin Solo. Fritz Kreisler	10
64382	Rigoletto—La donna è mobile (Woman Is Fickle) (Act III) (Verdi) Tenor Solo in Italian. Giovanni Martinelli	10
64437	Funiculi, Funicula, (Luigi Denza) Tenor Solo in Italian. John McCormack	10
74405	Requiem—Confutatis, from "The Accursed" (Verdi) Baritone Solo in Latin. Clarence Whitehill	12
87202	Contes d'Hoffmann—Barcarolle "Belle Nuit" (Oh, Night or Love) (J. Offenbach) Soprano and Contralto Duet in French. Alma Gluck and Louise Homer	10
64454	Gavotte from "Mignon" (Thomas-Sarasate) Violin Solo; pianoforte by George Falkenstein. Maud Powell	10
87194	Nabucco—Tremore gl'insani del mio (They Shall Tremble Before Me) (Act I) (Verdi) Baritone Solo in Italian. Titta Ruffo	10
64396	Haidenröslein (Hedge Rose) Op. 3, No. 3 (Goethe-Schubert) Mezzo-Soprano Solo in German with piano accomp. by Coenraad V. Bos. Julia Culp	10
17623	What Shall He Have Who Killed the Deer, from "As You Like It" (Shakespeare-H. R. Bishop) (with brass sextet). Victor Male Quartet	10
17624	Anvil Chorus, from "Il Trovatore" (God of the Nations) (Verdi) In English. Victor Male Chorus	10
17625	1. Granddaddy Longlegs; 2. Touching; 3. Katydid from "At Song Cycles Book No. 1 (W. Otto Miessner) (Piano accomp.) Published by Silver, Burdett & Co. Elsie Baker	10
17624	1. Violets; 2. Sweet-Pea Ladies; 3. Poppies, from "Songs of Child World" (Riley-Gaynor) with piano, violin and flute accomp. Olive Kline	10

NEW COLUMBIA DEPARTMENT

Opened in the Warerooms of the Tel-Electric Co., 299 Fifth Avenue, This Week.

The new Columbia department in the Tel-Electric Co.'s warerooms at 299 Fifth avenue, New York, opened last month, and judging from the interest already being manifested in the Columbia products by the store's patrons, this department will be a marked success under the able management of Charles F. Thayer. Five soundproof demonstration rooms are perfectly appointed for the convenience of customers, and the entire department is furnished in accord with the standards befitting the location of the Tel-Electric Co. in the heart of the city's high-grade shopping district.

J. C. ROUSH VISITS NEW YORK.

Pittsburgh Talking Machine Man an Ardent Tennis Fan and Attends Cup Tournament.

Joseph C. Roush, of the Standard Talking Machine Co., Pittsburgh, Pa., and ex-president of the National Association of Talking Machine Jobbers, was in New York several days recently attending the International Tennis Tournament for the Davis Cup, held on Long Island. Mr. Roush is a tennis enthusiast and thoroughly enjoys the exciting game. Before leaving for home he stated that conditions in the Pittsburgh district were encouraging and that the talking machine trade particularly was in excellent shape.

CHEMISCHE FABRIK E. SAUERLANDT **FLURSTEDT** bei Apolda i. Th., Germany

The largest manufacturing plant in the world devoted exclusively to the manufacture of Master-Waxes and Master-Blanks for

Gramophone and Phonograph Recording

Sole Manufacturer of Wax "P." the best recording material for Berliner-cut.

Leading Jobbers of Talking Machines in America

Landay
BROS INC

VICTOR JOBBERS Exclusively
What you want always in stock
427 Fifth Avenue
27 W. 34th Street
563 Fifth Avenue
153 W. 42d Street
New York

1856 **WURLITZER** 1914

VICTOR
DISTRIBUTERS
VICTORS EXCLUSIVELY

We make a specialty of getting the order out on time—every time.

The Rudolph Wurlitzer Co.
CINCINNATI and CHICAGO

Two points of supply; order from the nearer.

CHASE & WEST DES MOINES IOWA

Machines **Victor** Everything
Records in stock all
Cabinets the time.

WHOLESALE TO IOWA TRADE

Send us your name and address and we will mail you postpaid complete illustrated catalogues, giving detailed information concerning all Victor products. Showing the various styles of Victor Machines, list of all Victor Records, the entire line of Victor Cabinets, Repair Parts and all Accessories. Dealers, let us help you build a Victor Business.

PERRY B. WHITSIT L. M. WELLER

PERRY B. WHITSIT CO.,

213 South High Street, Columbus, Ohio.

Edison Phonographs and Records **JOBBERS** Victor Talking Machines and Records

**OLIVER
DITSON
COMPANY**

Largest VICTOR Talking Machine Distributors East of Chicago.

Creators of "The Fastest Victor Service." Let us tell you more about our service.

BOSTON

W. J. DYER & BRO.
Saint Paul, Minn.

VICTOR & EDISON
Distributors

Quick Service for all points in the Northwest. Machines, Records, Supplies.

Southern Victor Dealers

Largest Stock VICTROLAS and RECORDS.
Prompt Shipment and Low Freight Rates.

WALTER D. MOSES & CO.
Oldest Music House in Virginia or North Carolina.
RICHMOND, VA.



Where Dealers May Secure

COLUMBIA

Product

Ready, Full Stocks, and Prompt Deliveries from Convenient Shipping Centers all over the United States.

Distributors

- Atlanta, Ga., Columbia Graphophone Co., 132 Peachtree St.
- Baltimore, Md., Columbia Graphophone Co., 305-307 North Howard St.
- Birmingham, Ala., Columbia Graphophone Co., 1818 Third Ave.
- Boston, Mass., Columbia Graphophone Co., 174 Tremont St.
- Buffalo, N. Y., Columbia Graphophone Co., 622 Main St.
- Chicago, Ill., Columbia Graphophone Co., 14 N. Michigan Ave.
- Cincinnati, O., Columbia Graphophone Co., 117-119 W. Fourth Ave.
- Cleveland, O., Columbia Graphophone Co., 1375 Euclid Ave.
- Dallas, Tex., Southwest Talking Machine Co., 1101 Elm St. Columbia Building
- Denver, Colo., Columbia Stores Co., 505-507 Sixteenth St.
- Detroit, Mich., Columbia Graphophone Co., 114 Broadway
- Hartford, Conn., Columbia Graphophone Co., 719 Main St.
- Indianapolis, Ind., Columbia Graphophone Co., 27 N. Pennsylvania St.
- Kansas City, Mo., Columbia Graphophone Co., 1112 Grand Ave.
- Lincoln, Nebr., The Grafonola Company, 1036 O St.
- Livingston, Mont., Scheuber Drug Co.
- Los Angeles, Cal., Columbia Graphophone Co., 420-422 S. Broadway.
- Louisville, Ky., Columbia Graphophone Co., 425 South Fourth St.
- Milwaukee, Wis., Albert G. Kunde, 615 Grand Ave.
- Minneapolis, Minn., Columbia Graphophone Co., 424 Nicollet Ave.
- New Haven, Conn., Columbia Graphophone Co., 25 Church St.
- New Orleans, La., Columbia Graphophone Co., 934 Canal St.
- New York City, Columbia Graphophone Co., 59 Chambers St.
- Philadelphia, Pa., Pennsylvania Talking Machine Co., 1109 Chestnut St.
- Pittsburgh, Pa., Columbia Graphophone Co., 810 Bessener Building.
- Portland, Me., Columbia Graphophone Co., 550 Congress St.
- Portland, Ore., Columbia Graphophone Co., 371 Washington St. Eilers Music House
- Providence, R. I., Columbia Graphophone Co., 119 Westminster St.
- Rochester, N. Y., The Grafonola Company, 23 Clinton Ave., South.
- Sacramento, Cal., Kirk, Geary & Co.
- Salt Lake City, Utah, Daynes-Beebe Music Co., 45 Main St.
- San Francisco, Cal., Columbia Graphophone Co., 334 Sutter St.
- Seattle, Wash., Columbia Graphophone Co., 1311 First Ave.; Eilers Music House, 3d and University Sts.
- Spokane, Wash., Columbia Graphophone Co., 818 Sprague Ave.
- Springfield, Mass., Columbia Graphophone Co., 174 Worthington St.
- St. Louis, Mo., Columbia Graphophone Co., 1008 Olive St.
- St. Paul, Minn., Columbia Graphophone Co., 17 East Sixth St.
- Tampa, Fla., Tampa Hardware Co.
- Terre Haute, Ind., 640 Wabash Ave.
- Toledo, O., Columbia Graphophone Co., 229 Superior St.
- Washington, D. C., Columbia Graphophone Co., 1210 G St., N. W.

DEALERS WANTED—Exclusive selling rights given where we are not actively represented.

Write for particulars to the Columbia Graphophone Co., Wholesale Department, Hookworth Building, New York.

Headquarters for Canada:

Columbia Graphophone Co., 363-5-7 Sorauren Ave.

Toronto, Ont.

Every Jobber in this country should be represented in this department. The cost is slight and the advantage is great. Be sure and have your card in the October List.

SERVICE FIRST

EXCLUSIVE VICTOR JOBBERS
WHOLESALE ONLY

Standard Talking Machine Co.
PITTSBURGH, PA.

SANGER BROTHERS
Dallas, Texas

VICTOR
Distributors

"We ship the same day."

Edison Phonograph Distributors
for the SOUTHWEST
All Foreign Records in Stock.

Houston Phonograph Co., HOUSTON, TEXAS

NEW ENGLAND
JOBBER HEADQUARTERS
EDISON AND VICTOR
Machines, Records and Supplies.
THE EASTERN TALKING MACHINE CO.
177 Tremont Street BOSTON, MASS.

PACIFIC COAST DISTRIBUTORS OF
Victor Talking Machines and RECORDS
STEINWAY PIANOS LYON & HEALY
"OWN MAKE" BAND INSTRUMENTS
Sherman, Clay & Co. San Francisco Portland
Oakland Los Angeles

**The Chicago
Edison Jobber**

The perfection of Musical Instruments—THE EDISON diamond disc PHONOGRAPH—with EDISON double disc records.

THE PERFECTION OF SERVICE—Our Service.

The Perfection of advertising for the dealer—Our plan.

The Phonograph Company
229 So. Wabash Ave. CHICAGO



It's easy to sell the Edison Phonograph. The instrument is its own best salesman. It tells its own selling story with inevitable conviction.

But don't forget that to meet the desires of all sorts of customers you must carry the full line of Edisons.

Thomas A Edison
INCORPORATED

59 Lakeside Ave., ORANGE, N. J.



The TALKING MACHINE WORLD

AND
NOVELTY
NEWS

Published Each Month by Edward Lyman Bill at 373 Fourth Avenue, New York, October 15, 1914



The best-known trade mark in the world

“The Victor talking machine’s design, ‘His Master’s Voice,’ has become a household word, and the quaint little fox terrier at attention before the horn is familiar to more Americans than any of the world’s great masterpieces”—*Collier’s Weekly*.



INSTALLATION FOR THE AEOLIAN CO.



INSTALLATION FOR NEAL, CLARK & NEAL CO.

Unico Demonstrating Booths

Will Sell MORE Player-Pianos

These booths are built on the Unit system; can be taken down and put up again in a few hours; made in multiples of three feet, so you can enlarge or reduce your booths as desired, and without labor charges. Every Unit is interchangeable.

Made in eight regular designs, and are both SOUNDPROOF and DUSTPROOF.

Woods furnished: Oak, Birch, Quartered Oak and Mahogany. Special finishes on order.

Unico Booths increase the sales of Talking Machines, Player-Pianos, Music Rolls and records, for customers always buy better goods—and more goods—with artistic surroundings.

The cost of Unico Booths is less than you would pay in your own City, irrespective of our Patent Construction and Superior Quality.

Just look at this partial list of high-grade houses where Unico Demonstrating Booths are selling more Player-Pianos.

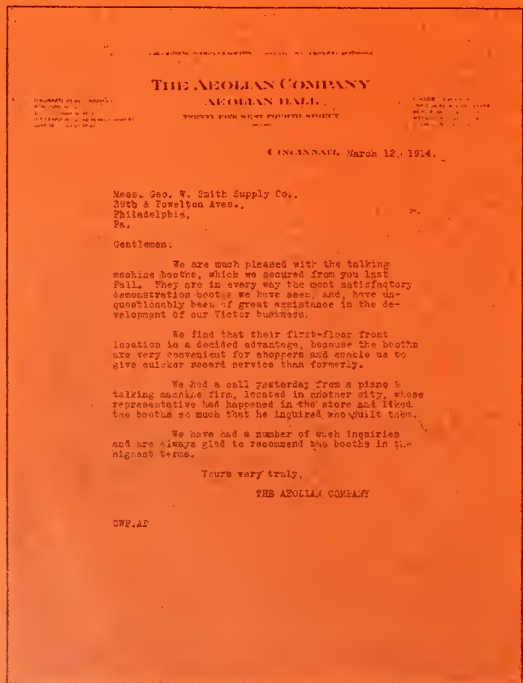

What the Aeolian Co. says about Unico Booths.

Illustrated Catalog and Prices
Mailed Upon Request

Lyon & Healy
Rudolph Wurlitzer Co.
Frederick Piano Co.
Pease Piano Co.
Gimbel Brothers
John Wanamaker
Krell Piano Company
E. F. Droop & Sons Co.
Aeolian Company
Lyric Piano Company
Fulton Music Company
Humes Music Company
Clayton Piano Co.
Cunningham Piano Co.
R. H. Macy & Company
B. S. Porter & Son
Neal, Clark & Neal
The Aeolian Company
The Aeolian Company
Koerber-Brenner Co.
The Allen-Johnson Co.
Blackman Talking Machine Co.
D. S. Andrus
Stewart Bros.
Bloomingdale Bros.
Block & Kuhl Co.
Paul, Gale Greenwood Co.
Jas. McCreery & Co.
Linn & Scruggs Dry Goods Co.
Steger & Sons Piano Co.
Story & Clark Piano Co.

Chicago, Ill.
Cincinnati, O.
Pittsburgh, Pa.
Brooklyn, N. Y.
New York City.
Philadelphia, Pa.
Cincinnati, O.
Baltimore, Md.
New York City.
Cincinnati, O.
Waterbury, Conn.
Columbus, Ga.
Salt Lake City.
Philadelphia, Pa.
New York City.
Lima, Ohio.
Buffalo, N. Y.
New York City.
Cincinnati, O.
St. Louis, Mo.
Eau Claire, Wis.
New York City.
Elmira, N. Y.
Columbus, Ohio.
New York City.
Peoria, Ill.
Norfolk, Va.
New York City.
Decatur, Ill.
Newark, N. J.
Chicago, Ill.

Geo. W. Smith & Co.

Sloane Street and
Powelton Avenue

PHILADELPHIA



The Talking Machine World

Vol. 10. No. 10.

New York, October 15, 1914.

Price Ten Cents

METROPOLITAN PHONO CO. FORMED.

New Concern Takes Over the Retail Business of Benj. Switky—Headed by Wm. S. Finberg, President, and David Kahn, Secretary and Treasurer—Business to Be Developed.

The Metropolitan Phono Co., Inc., recently organized and incorporated under the laws of New York, formally took over the retail business of Benjamin Switky, the Victor distributor at 9 West Twenty-third street, New York, on October 5, following Mr. Switky's announced intention of confining himself to the wholesale business exclusively in the future.

The officers of the new company are William S. Finberg, president, and David Kahn, secretary and treasurer. Mr. Kahn is already well known to the trade, having joined the retail staff of Mr. Switky about ten years ago as errand boy and working up steadily to a position that represented what was practically the management of the retail business. His knowledge of the talking machine business in general and the retail end in particular should ensure his success in the new venture. Mr. Finberg is a prominent real estate man and is amply supplied with capital.

Mr. Kahn, who will look after the actual management of the business, will retain the present staff of the store and also make several additions necessary to the development of the business.

THE OPERA IN THE HOME.

In Lieu of Its Presentation in the Opera House Emphasized by the New York Talking Machine Co.—Clever Window Display, Based on Cartoon, Attracts Wide Notice.

The New York Talking Machine Co., 81 Chambers street, New York, Victor distributor, intro-



Grand Opera Window of New York Talking Machine Co.

duced recently a special window display which is attracting the attention of all passers-by on Chambers street. This display, which was conceived by J. T. Owens, of the company's staff, embodies a number of timely attributes which give it unusual distinctiveness.

The display is based on a cartoon which appeared in a local newspaper entitled, "If the opera stars can't come back in time—why not this at the Metropolitan?" and showing the wooden figures of Caruso, Scotti and Farrar standing in front of talking machines with notes issuing from their mouths, which in this drawing are the big ends of the phonograph horns.

Mr. Owens decided that the opera "Mme. Butterfly" would well carry out the idea of the cartoon, and a cut-out display of an opera house was designed with the evening's performance scheduled as "Mmc. Butterfly" and the appearing artists as Caruso, Scotti, Farrar and Homer. To carry out the plan bulletin boards listing all the Victor records from this popular opera were placed on either side of the opera house and actual scenes from the opera clipped from the Victor Book of Operas

were also displayed in bulletin form. The completed display was perfect in every detail and well deserving of the praise it received.

POMMER BUSINESS TRANSFERRED.

Ellas Marx Co. Takes Over Talking Machine Business of A. J. Pommer Co., Sacramento.

(Special to The Talking Machine World.)

SACRAMENTO, CAL., October 9.—The A. J. Pommer Co., one of the largest talking machine houses in the interior of California, has just closed a deal whereby its business is transferred to the Ellas Marx Co., a leading piano house of this city. The name of A. J. Pommer has for many years been prominently identified with the piano and talking machine business of California, the piano department having been discontinued a few years ago; while the Ellas Marx Co., whose standing is materially increased by this deal, is known as one of the pioneers of the trade of central California.

FORESEES END OF DEPRESSION.

Optimism, John Wanamaker Says, Is Great Need in the United States Now.

(Special to The Talking Machine World.)

PHILADELPHIA, PA., October 8.—John Wanamaker expressed his firm belief that the present business depression is only temporary in an address at a luncheon at the St. James recently, attended by members of the Walnut Street Business Association, Rotary Club and Merchants and Manufacturers' Association.

"Business is in a condition of unpleasantness, unhealthfulness and fear," he said. "Our present need is to discover the best way to get business on to the double track of safety, out of the darkness into light, to find a way for courageous feet and to see a vision of returning good times.

"My great hope, indeed I may say my firm belief to-day, is that this condition is only temporary. We can shorten it, and it is our duty not to talk down but to talk up. We must first get ourselves in an optimistic frame of mind, for the man who is discouraged can discourage the man who is next to him. If a man has health and strength he has no right going about with a long face, as he only makes things harder for himself and for those about him.

"We have gone through a hard time, but conditions that exist are here, and are not simply the result of politics or of war in Europe. The tariff has had a great deal to do with the unrest, the mills closing because capital cannot be had as usual.

"As for the income tax, it is good, sound sense to make the rich men bring out their money, but it touches all such as ourselves, for there is just that much money less in circulation. I have no fault to find. We elected splendid people who notified us in advance what they would do. We are talking now not of cause, but of effect.

"In all cities business men have been affected by the present condition of banking capital. The Federal reserve act will work out great good. Money, however, is like merchandise—the highest bidder gets it."

The West Music House, one of the oldest music houses in Joliet, Ill., has recently remodeled its quarters to make room for new demonstrating booths in the Victor talking machine department. This branch of the business is steadily expanding.

MOVED TO NEW QUARTERS.

Humes Music Company of Columbus, Ga., Now Has One of the Finest Talking Machine Departments in South—Install Unico Booths.

(Special to The Talking Machine World.)

COLUMBUS, GA., October 6.—In moving from their old location to their new store at 1032 Broad street, the Victor talking machine department of Humes Music Co. has undergone quite a change. In place of the improvised display room in the back of the store it is now in the front of the store and is equipped with two sound-proof demonstration rooms of Unico construction. C. C. Gibson formerly of Phillips & Crew Co., Atlanta, is in charge of this department and is anticipating quite a large increase in business this season.

COLUMBIA MANAGERIAL CHANGES.

Recent Changes and Transfers of Managers in the Various Branches of the Columbia Co. Throughout the Country.

The Columbia Graphophone Co. announced last week a number of important changes concerning the personnel of the managers of its various branches throughout the country. It is interesting to note in this connection that the company in making the changes and transfers has followed its successful policy of promoting the men who have been in its employ for any length of time in preference to securing the services of outsiders.

Frederick Dennison, manager of the Baltimore headquarters of the Columbia Co. for several years, has been placed in charge of the Detroit branch, where he will be given a broader field for development and expansion.

George A. Baker, assistant manager of the Columbia Co.'s wholesale establishment at 89 Chambers street, New York, has been promoted to the management of the Baltimore store, an advance that he well deserves.

Kenneth Johns, formerly manager of the Detroit store, will join the Columbia Co.'s offices in New York, occupying an important post.

J. D. Westervelt, formerly agency supervisor of the Dictaphone division of the Columbia Co., has assumed charge of the Dictaphone business of the Pennsylvania Talking Machine Co., Philadelphia, Pa.

T. L. McManus, a special salesman from the executive offices of the Dictaphone department, has been placed in charge of the Springfield, Mass., branch of the Columbia Co.

VICTOR CO. TO BUY 2,000 BALES.

Orders Bale of Cotton Through Every Victor Dealer in Cotton Belt—A Big Total.

(Special to The Talking Machine World.)

ATLANTA, GA., October 9.—The "Buy-a-Bale-of Cotton" movement Monday morning is given another big boost by a purchase of 2,000 or more bales at 10 cents a pound by the Victor Talking Machine Co., of Camden.

The company will buy one bale through each of its dealers in the cotton belt, and it has at least 2,000 dealers and probably more in this section. The cotton is to be bought by the dealers direct from farmers and is to be shipped to the company's warehouse in Philadelphia.

The Elyea-Austell Co., of this city, which is a Victor distributor here, and the wholesale representative, made the announcement of the company's big purchase, which amounts to \$100,000 or more. The purchase, in fact, is the direct result of solicitation on the part of the Elyea-Austell Co. It took the "Buy-a-Bale" matter up with the Victor Co. when the movement started several weeks ago. It suggested that the Victor Co. buy 250 bales, and the company responded by buying 2,000 bales.

PACIFIC COAST DEALERS PLACING LIBERAL ORDERS.

Jump in Wholesale Business Indicates Faith in Coming Holiday Season—Elaborate Columbia Exhibit for Panama-Pacific Exposition—New Edison Shop Opens in San Francisco—Encouraging News from the Interior—New Stores Recently Opened—News of Month.

(Special to The Talking Machine World.)

SAN FRANCISCO, CAL., October 3.—There has been a notable wholesale movement of talking machines during the last few weeks. Dealers throughout the country have been in the market for both talking machines and records; and the general expectation seems to be for a good lively fall and winter trade. The orders have not as a rule been particularly large; but they have been numerous and have been restricted to no particular section of the Coast territory. With the close of the harvest season and the advent of money received from the sale of these, country retail business has also begun to pick up, though the heavy selling in the country will not come till a little later. City retail trade is also showing signs of the regular fall activity, and the general talk around the talking machine departments is of the optimistic sort. The fact that in practically all cases where there is any remodeling being done at the music houses there is also an enlargement of the space allotted to talking machines shows what the dealers are expecting of the fall and holidays.

Planning for Elaborate Columbia Exhibit.

W. S. Gray, manager of the Pacific Coast territory for the Columbia Graphophone Co., reports a good start made on the fall trade, the volume of the business done to this date being somewhat larger than for the same date last year. The opening of new talking machine departments by music dealers and others in the smaller cities and towns of the Coast being more noticeable than usual. Mr. Gray is now beginning to give some little thought to the exhibit which the Columbia people will put in at the Panama-Pacific Exposition. The exposition buildings and grounds are now all complete and ready for the installation of exhibits, and exhibitors are beginning to work out their plans in detail. A fine showing of Columbia machines and records was made by the Wasserman-Gattmann Co., of Sacramento, Cal., at the California State Fair in that city last week.

Formal Opening of New Edison Shop.

The new Edison shop on Geary street has been the big thing in the San Francisco talking machine trade for the past two weeks. This store held its formal opening on September 24, and on that day and on each succeeding day has been offering special concerts for the entertainment of visitors. The new store and the daily concerts have been given a liberal advertising, running from half to whole pages in the daily papers, and Manager

James S. Baley reports that results have been of the most cheerful sort. On the opening day concerts succeeded each other almost without intermission from 8.30 in the morning until 5 at night. A total of more than ninety numbers were given.

Take Advantage of Los Angeles Fashion Show.

The Fall Fashion Show at Los Angeles during the week of September 21-26 was utilized by the Los Angeles music houses as a sort of fall opening for the retail talking machine departments. Special window displays were made by nearly all the larger stores. A number of the stores, including the Geo. J. Birkel Co., the Wiley B. Allen Co., and the Southern California Music Co., were given special mention by the press in the write-ups of the Fashion Show.

Remodeling Store in Santa Barbara.

The talking machine store of Ralph M. Paulin, at Santa Barbara, Cal., is now in the midst of a general remodeling and refitting. An artistic entrance has been put in connecting Mr. Paulin's store with the piano store of the Brown Music Co. New demonstration rooms have been added, and the reception room has been refitted.

More Space for Eilers Department.

Manager Rothermel, of the talking machine department at the Eilers Music Co., San Francisco store, has prevailed on the company to grant him some valuable additional ground floor space in the big Market street store. The growth of business in his department and the prospects for a very busy fall left the department a little short of demonstration rooms. A special demonstration room for Edison disc machines has now been completed.

Adds Talker Department in Modesto, Cal.

H. Hinz, a well-known music man of Modesto, Cal., who has been in business in that county for many years, has now added a talking machine department to his store. In this, he has associated himself with J. J. Morgan, of San Francisco, who was formerly manager of the talking machine department of the Emporium department store.

Preparing for Big Season in San Diego.

The San Diego store of the Southern California Music Co., is preparing for a big season in the talking machine department, partly as a result of the near-by opening of the Panama-California Exposition in that city, and partly as a result of natural growth. Arrangements are being made to handle additional business. The management of the San Diego store has now been placed in charge of Leonard Newton, for several years manager of

the talking machine end of the Los Angeles store. Mr. Newton took up his new work about the middle of September.

New Department in Visalia, Cal.

A complete talking machine department will be installed in the new music store of the Wiley B. Allen Co., at Visalia, Cal. A good location has been secured on North Court street. T. F. Sibley, of Visalia, will be in charge of the store, the special talking machine man having not yet been selected.

Clark Wise & Co. Expand.

Clark Wise, of Clark Wise & Co., Geary street dealers, say that they have again found it necessary to take additional space for their talking machine department. Some additional demonstration rooms have been added in preparation for the normal fall increase in business.

Increases Stock of Edison Products.

The Curtis & Henkle Drug Co., of San Jose, Cal., has expanded its talking machine department and is now carrying a larger stock of Edison machines and records than ever before. Arrangements have been made to get in shipments of new Edison records each week.

New Stores and Changes.

L. C. Ackley, of San Fernando, Cal., has secured a new location, which is now being put in shape. He expects to get moved within a couple of weeks.

W. D. Evans, of Antioch, Cal., will shortly organize the Contra Costa Music Co., to take over his business with the idea of doing a little expanding.

R. Hosmer has opened at Berkeley, Cal., with a line of talking machines and other musical goods.

The Burditt Piano Co., which opened a music store at Pomona, Cal., a few weeks ago, has put in a complete line of Columbia machines, and is preparing to give this line a good representation during the fall and winter.

A. L. Gardner, of Bakersfield, Cal., was a trade visitor in San Francisco a couple of weeks ago.

DEALERS' ASSOCIATION TO MEET.

J. G. Bremner, president of the Eastern Talking Machine Dealers' Association, states that, with the opening of fall, the regular meetings of that body will be resumed for the discussion of various trade questions. The date of the first fall meeting has not yet been announced, but will be decided upon soon.

An American Consul in England reports a company in his locality desirous of securing names of American manufacturers of talking machine motors and fittings. Manufacturers wishing to communicate with this company should address the Bureau of Foreign and Domestic Commerce, Department of Commerce, Washington, D. C., referring to Foreign Trade Opportunity No. 13739.

The Success of Your Talking Machine Department

Is to a *large* extent dependent upon the service your distributor gives you.

This admitted makes it important that you secure the best service obtainable.

AND THAT IS EASTERN SERVICE

To use it is to swear *By* it not *At* it.

May we not have the opportunity to convince you that our service is exceptional?

EASTERN TALKING MACHINE COMPANY

177 TREMONT STREET, BOSTON, MASS.

EDISON

FOR NINETEEN YEARS TALKING MACHINES EXCLUSIVELY

VICTOR

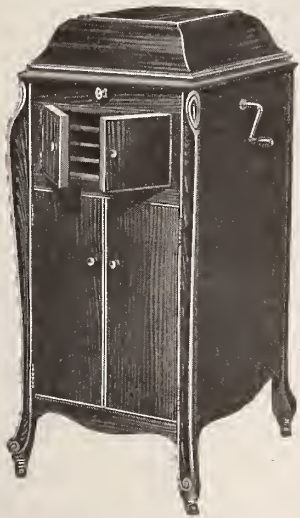

Victrola XI, \$100
Mahogany or oak

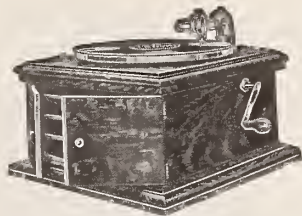

Victrola VI, \$25
Oak

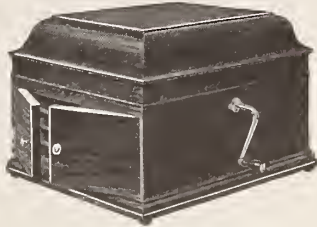

Victrola IX, \$50
Mahogany or oak

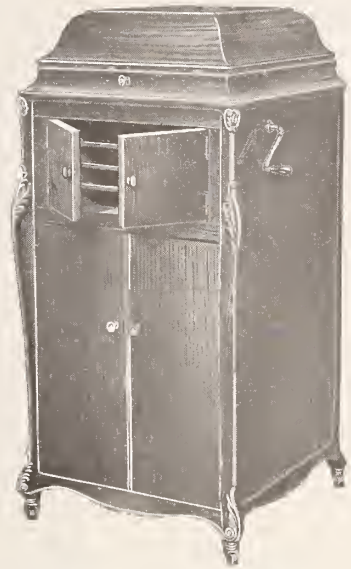

Victrola XVI, \$200
Mahogany or oak

“Will there be a Victrola in your home this Christmas?”

This important question will confront the people of the whole country right on until Christmas.

It is the key-note of our nation-wide holiday advertising campaign, and its force will send thousands of customers into the stores of Victor dealers everywhere.

It will help to make this the biggest holiday season you ever had—even ahead of the phenomenal business of last Christmas.

Victor Talking Machine Co., Camden, N. J., U. S. A.

Berliner Gramophone Co., Montreal, Canadian Distributors.

Always use Victor Machines with Victor Records and Victor Needles—the combination. There is no other way to get the unequalled Victor tone.



Victor Distributors

Albany, N. Y..... Finch & Hahn.
 Altoona, Pa. W. F. Frederick Piano Co.
 Atlanta, Ga. Elyea-Austell Co.
 Phillips & Crew Co.
 Austin, Tex. The Talking Machine Co., of
 Texas.
 Baltimore, Md..... Cohen & Hughes, Inc.
 E. F. Droop & Sons Co.
 H. R. Eisenbrandt Sons.
 Bangor, Me. Andrews Music House Co.
 Birmingham, Ala.... Talking Machine Co.
 Boston, Mass..... Oliver Ditson Co.
 The Eastern Talking Machine
 Co.
 M. Steinert & Sons Co.
 Brooklyn, N. Y..... American Talking Machine Co.
 Buffalo, N. Y..... W. D. Andrews.
 Neal, Clark & Neal Co.
 Burlington, Vt..... American Phonograph Co.
 Butte, Mont..... Orton Brothers.
 Chicago, Ill..... Lyon & Healy.
 The Talking Machine Co.
 The Rudolph Wurlitzer Co.
 Cincinnati, O..... The Rudolph Wurlitzer Co.
 Cleveland, O..... The W. H. Buescher & Sons Co.
 The Collister & Sayle Co.
 The Eclipse Musical Co.
 Columbus, O..... Perry B. Whitsit Co.
 Dallas, Tex..... Sanger Bros.
 Denver, Colo..... The Hext Music Co.
 The Knight-Campbell Music Co.
 Des Moines, Ia..... Chase & West Talking Mach. Co.
 Mickel Bros Co.

Detroit, Mich..... Grinnell Bros.
 Elmira, N. Y..... Elmira Arms Co.
 El Paso, Tex..... W. G. Walz Co.
 Galveston, Tex..... Thos. Goggan & Bros.
 Honolulu, T. H..... Bergstrom Music Co., Ltd.
 Indianapolis, Ind.... Stewart Talking Machine Co.
 Jacksonville, Fla.... Florida Talking Machine Co.
 Kansas City, Mo.... J. W. Jenkins Sons Music Co.
 Schmelzer Arms Co.
 Lincoln, Neb..... Ross P. Curtice Co.
 Little Rock, Ark.... O. K. Houck Piano Co.
 Los Angeles, Cal.... Sherman, Clay & Co.
 Louisville, Ky..... Montenegro-Riehm Music Co.
 Memphis, Tenn..... O. K. Houck Piano Co.
 Milwaukee, Wis..... Badger Talking Machine Co.
 Mobile, Ala..... Wm. H. Reynolds.
 Montreal, Can..... Berliner Gramophone Co., Ltd.
 Nashville, Tenn..... O. K. Houck Piano Co.
 Newark, N. J..... Price Talking Machine Co.
 New Haven, Conn.... Henry Horton.
 New Orleans, La.... Philip Werlein, Ltd.
 New York, N. Y..... Blackman Talking Machine Co.
 Emanuel Blout.
 C. Bruno & Son, Inc.
 I. Davega, Jr., Inc.
 S. B. Davega Co.
 Chas. H. Ditson & Co.
 Landy Brothers, Inc.
 New York Talking Machine Co.
 Ormes Inc.
 Silas E. Pearsall Co.
 Benj. Switky.

Omaha, Neb..... Nebraska Cycle Co.
 A. Hospe Company.
 Peoria, Ill..... Putnam-Page Co., Inc.
 Philadelphia, Pa.... Louis Buehn.
 C. J. Hepp & Son.
 Penn Phonograph Co., Inc.
 The Talking Machine Co.
 H. A. Weymann & Son, Inc.
 Pittsburgh, Pa..... C. C. Mellor Co., Ltd.
 Standard Talking Machine Co.
 Portland, Me..... Cressey & Allen, Inc.
 Portland, Ore..... Sherman, Clay & Co.
 Richmond, Va..... The Corley Co., Inc.
 W. D. Moses & Co.
 Rochester, N. Y..... E. J. Chapman.
 The Talking Machine Co.
 Salt Lake City, Utah Consolidated Music Co.
 San Antonio, Tex.... Thos. Goggan & Bros.
 San Francisco, Cal.... Sherman, Clay & Co.
 Savannah, Ga..... Phillips & Crew Co.
 Seattle, Wash..... Sherman, Clay & Co.
 Sioux Falls, S. D.... Talking Machine Exchange.
 Spokane, Wash..... Sherman, Clay & Co.
 St. Louis, Mo..... Koerber-Brenner Music Co.
 St. Paul, Minn..... W. J. Dyer & Bro.
 Syracuse, N. Y..... W. D. Andrews Co.
 Toledo, O..... The Whitney & Currier Co.
 Washington, D. C.... Robert C. Rogers Co.
 E. F. Droop & Sons.

FAMOUS RECORD ALBUMS

AT VERY LOW PRICES TO MEET COMPETITION

These Record Albums will Pay for Themselves in a short Time by Preserving Records. When Full the Albums are Flat and Even Like Books. They will Fit in a Library Cabinet or Book Case, or They will Lie Flat on One Another.

For Durability, Artistic Design and Finish, our Albums have no equal. They are made in the most substantial manner by skilled workman. We sell our Superb Albums at big discounts to meet competition. Shall we send samples and quote our very low prices?

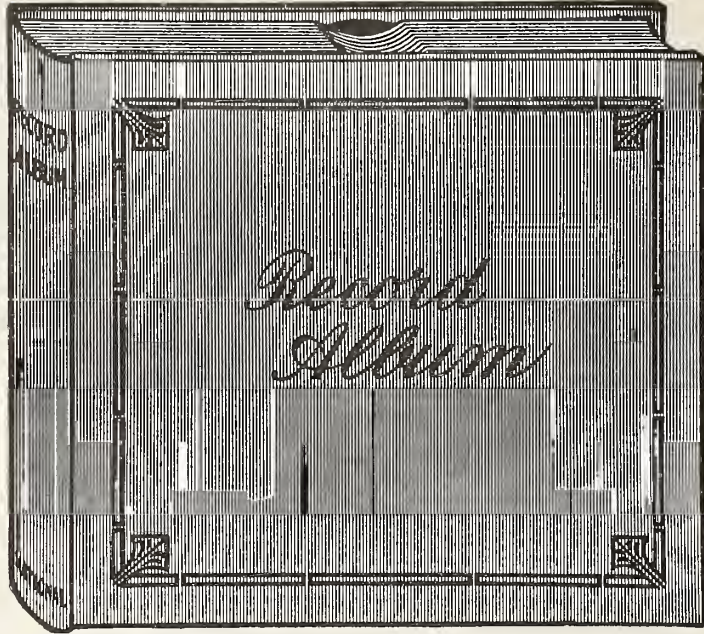

DISC RECORD ALBUMS
ARE WHAT EVERY
Talking Machine Owner
MUST NOW HAVE

With the index they make a complete system for filing away all disc Records, and can be added to, Album by Album, as Records accumulate, like books in a library.

THESE ALBUMS ARE THE BEST FOR VICTOR, EDISON,
COLUMBIA AND ALL OTHER DISC RECORDS

Write for samples of our Albums, which are superior to all others

Address NATIONAL PUBLISHING CO., 235 South American St., Philadelphia, Pa.

ACTIVITY IN TWIN CITY TRADE.

Minnesota Phonograph Co. Opens Store in St. Paul—Jobbers Report Heavy Demand for Machines and Records—Talking Machine Co. Giving Recitals—General News.

(Special to The Talking Machine World.)

MINNEAPOLIS and ST. PAUL, MINN., October 5.—A new store opened last week in St. Paul under the name of the Minnesota Phonograph Co. in the triangle building at Sixth and St. Peter streets. With fronts on three streets and in the heart of a section that many students believe will be the coming shopping district of St. Paul, the store is well located for good business. William Lucker, the manager, states that more than \$5,000 has been expended in the demonstration booths and other phonograph equipment, and the appearance fully bears out the statement. While the store already is occupied, it is not wholly completed and the formal opening has been deferred. Edison phonographs and Victor talking machines will be handled on a large scale in this new place.

Victrola business is booming not only in Minneapolis and St. Paul, but throughout the entire country, for which the Twin Cities are the jobbing center. These houses know nothing about war except that it brings them additional demand for patriotic music records. There are ten Victor stores in the two cities and all without exception report their September business as the best ever.

The Talking Machine Co., Archie Matheis, manager, inaugurated Thursday night a series of weekly recitals. The plan which was tried last season proved so attractive that it was resumed again for the present season. The store was filled to its utmost and the recitals will now be a regular event until next summer. Mr. Matheis has published a prospectus of his line which is an attractive little volume in every way. There was good business since September opened, and things look inviting for a good fall trade. A new crosstown

car line on Eleventh street is likely to bring a great deal of additional trade to upper Nicollet avenue, and the Talking Machine Shop will be in line for its share.

Work is being rushed on the new Minneapolis store of the Minnesota Phonograph Co. at 612 Nicollet avenue. The opening is set for October 20. Manager Laurence H. Lucker is now in the East, meaning Orange, N. J., to get additional stock for the new shop. The old store at 515 Marquette avenue will be retained for general office and storage purposes, but it is proposed to make the new place the chief retail store, although it virtually will be a branch of the business. In casting up its records the other day it was found that thirty-two pianos and three players had been taken in exchange for Edison phonographs during the present year. The cylinder machines still sell readily, but the people of means want the disc.

George W. Lyle, general manager of the Columbia Graphophone Co., visited the Minneapolis and St. Paul stores Saturday, October 3, and is believed to have found business moving briskly.

DANCING EXHIBITION ATTRACTS

In Los Angeles, Where the Southern California Music Co. Has Been Utilizing the Victrola to Furnish Music for Two Prominent Artists.

(Special to The Talking Machine World.)

LOS ANGELES, CAL., October 5.—The Southern California Music Co., of this city, live-wire Victor dealer, has been utilizing the Victrola to furnish music for two prominent dancers who have been giving exhibitions in its store. These dancers, Miss Norma Gould, assisted by Erwin Volze, have been rendering interpretations of the latest dances to the music of a Victrola with signal success. The exhibitions have attracted crowds to the company's store, and the large attendance was so gratifying that the company has decided to give instructions and demonstrations twice a week to which the public are invited to participate.

CONDITIONS IN THE SOUTH

Are Not as Favorable in a Business Way as They Ought to Be Owing to the Farmers Being Unable to Realize on Their Cotton, Says E. N. Upshaw of the Elyea-Austell Co.—Approves of World Editorial.

E. N. Upshaw, of the Victor department of the Elyea-Austell Co., of Atlanta, Ga., writes the editor of The Talking Machine World under date of September 20 as follows:

"Dear Sir:—We wish to express our approval of your editorial in the current issue of The World regarding the fallacy of the idea of armed peace. It strikes the writer as quite a coincidence that only last Sunday he heard one of the leading ministers of the city in his sermon use almost identically the same words in regard to this proposition as your editorial uses.

"We consider that the demands of business men and commerce in general will do more to promote world peace than any other one thing. Even now there is talk of the bankers and moneyed men of Germany bringing pressure to bear upon the Emperor to force him into discussing terms of peace with the other nations.

"General conditions throughout the South are pretty much at a standstill owing to the fact that so far we have been unable to market our cotton. The 'buy-a-bale-of-cotton' movement proposition has done much to restore confidence, and very likely by the time you go to press again the South will be running along at least under normal conditions. Business is holding up to just about what it was last September, and if the South can only realize on its cotton we will finish the fall with a very decided increase over last fall. The South is hit harder on account of the war than any other section, owing to the closing down of the numerous cotton mills in Europe, the Stock Exchange and the tightening up of money which prevents the disposing of its cotton at any price whatever."



Victrola IV, \$15
Oak

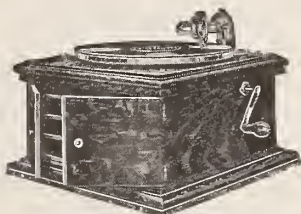

Victrola VI, \$25
Oak

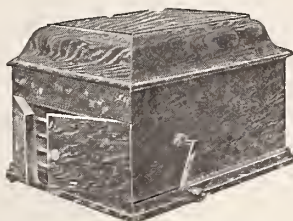

Victrola VIII, \$40
Oak



Victrola IX, \$50
Mahogany or oak

“Will there be a Victrola in your home this Christmas?”

That is the question being put before the entire country in the extensive Victor advertising.

That is the question which is going to be settled in thousands of homes—and settled to your satisfaction.

That is the question which will help to make a new high record for Victor Christmas business.

So don't lose sight of the value to you of the Victor holiday advertising and “Will there be a Victrola in your home this Christmas?”



Victor Talking Machine Co.

Camden, N. J., U. S. A.

Berliner Gramophone Co., Montreal, Canadian Distributors.

Always use Victor Machines with Victor Records and Victor Needles—the combination. There is no other way to get the unequalled Victor tone.

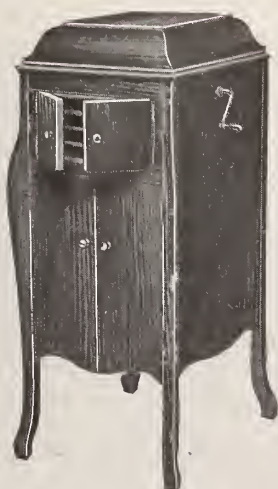

Victrola X, \$75
Mahogany or oak

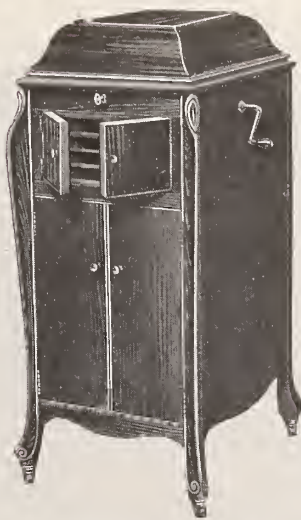

Victrola XI, \$100
Mahogany or oak



Victrola XIV, \$150
Mahogany or oak

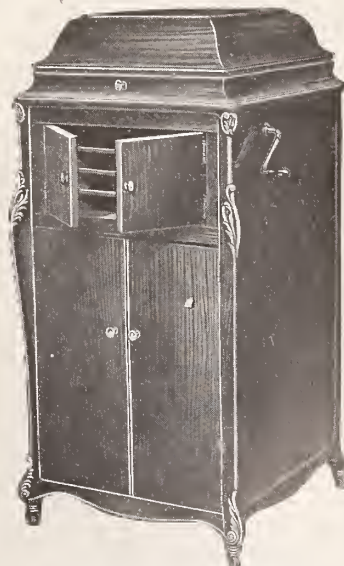

Victrola XVI, \$200
Mahogany or oak

WINDOW TRIMMING FOR TALKING MACHINE DEALERS.

Ellis Hansen, the Well-Known Expert and Display Manager of the Wurlitzer Co., Chicago, Says That Window Display Is the Best and Cheapest Kind of Advertising—Getting "News Value" in Window Trims—Taking Advantage of Fads and Seasons for Display.

It was left to the youngest and, perhaps, the most progressive branch of the music trade, the talking machine dealer, to fully understand the great advertising value of the show window. It is now generally realized that a well-dressed window display is the best and cheapest advertising medium at a retail dealer's command. It has grown steadily and artistically until to-day it overshadows in importance almost any other kind of advertising. A successful display must not only attract attention, but be pleasing and efficient. Anything unusual will stop people, but unless it makes friends and sells goods, it is not a successful display.

The talking machine dealers are fortunate in having an article that is particularly well suited for a successful window display. Talking machines and records are very suggestive. There is always "something doing." Its close connection with people in the public eye makes it not only possible, but easy, to get that quality that newspaper men call "news value" into a "talker" trim.

Taking Advantage of Concert Tours.

To illustrate my point: Take the concert tours of famous musical artists. Weeks before the artist arrives in your city the local paper contains not only advertisements, but pictures and articles about the concert. This is your chance to make

grateful hearts the joy and happiness contributed by the famous composers of our sister nations throughout the world. To all European countries we extend our sincerest good fellowship along

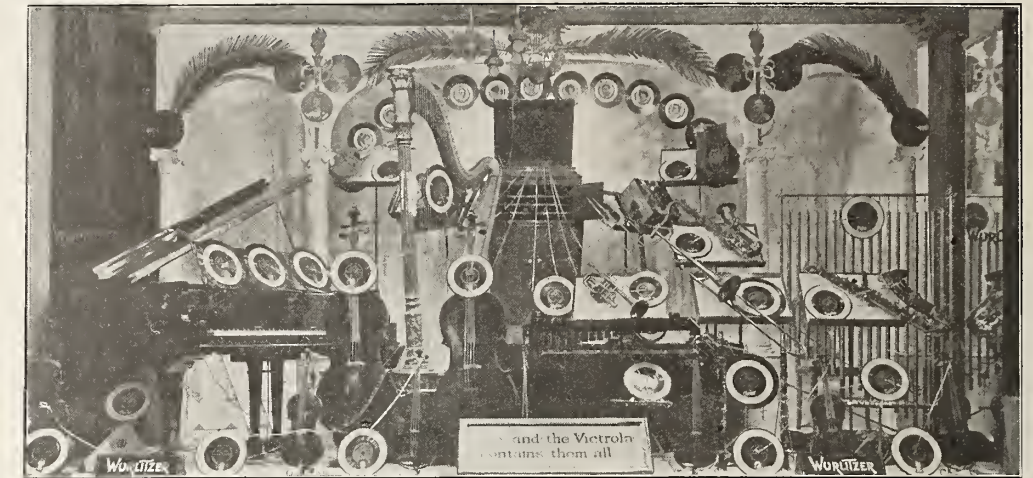

Fig. 1—A Striking Window Embracing a General Line of Musical Instruments.

with our expressions of neutrality, fairness, friendship and, in the undying words of our immortal Lincoln, 'With charity for all and malice towards none.'

Two American flags should be draped on either

concentrate your mind on the subject and have a definite idea of the message you expect to convey. It is not always beauty alone that counts, but the idea that is behind the display. To illustrate this, study picture Fig. 1. In this display I wished to bring out strongly the wonderful versatility of the Victrola. In the show window was placed a collection of practically every modern musical instrument from a grand piano to a piccolo—harp, violins, cellos, trombones, cornets, clarinets, saxophone, flute, bells, chimes, banjo, mandolin,

zither, accordeon, and many other instruments. With each instrument was a Victor record made by some celebrated artist on that particular instrument. Fifteen vocal records headed by Caruso and Melba and with pictures of each singer were also used in the display. Connected with each record that extended to a Victrola in the background. The only show card read: "— and the Victrola contains them all." The display demonstrated the point so clearly that it attracted a great deal of attention.

Foreign Record Display (Fig. 2).

This display was put in recently to advertise the new Swedish, Danish, Norwegian and Finnish records used by the Victor Co. Hence the Viking ships were used. These were cut from heavy cardboard and painted so that they stood out in strong relief. A row of overlapping records was placed along the side of each ship in imitation of the warriors' shields that are always shown in pictures placed this way.

On the sails of the first ship was written, "New Victor Records from the land of the Vikings." On the second ship, "Victor Records in Twenty-six Languages." Notice the sea gulls flying in the direction of the ships. These were painted on cardboard, cut out and extended by threads. The display was considered very picturesque.

(Continued on page 9.)



Fig. 2—Window Especially Devoted to Swedish, Danish, Norwegian and Finnish Records.

an effective display with the records of the artist. A large picture and a show card in connection with the records, plus the publicity in your city papers will add a great deal of additional interest in your display, and, no doubt, result in increased sales of that artist's records. The only expense a display of this sort will entail is the cost of the picture and sign work.

side of the American sign and the small flags should be arranged with each foreign record. A display of this sort at the proper time will not only make people acquainted with the fact that you sell foreign records but also create a lot of talk about your store.

How to Make an Interesting Display.

To make an interesting display you must first

News and Patriotism.

Another example of "news value": Some weeks ago President Wilson sent an appeal to the American people to be strictly neutral and careful in expressing opinions of the war in Europe on account of the many foreigners that have made this country their home. This gave me the idea for an unusual display. Make two or three steps or shelves in your window and arrange as many foreign records as there are nations in Europe on the steps. Get small European flags corresponding to the records (these can be purchased in department stores at 5 or 10 cents each). Have a sign made in the shape of an American shield and fasten to this the record of "The Star Spangled Banner." Have the following copy under the American record:

"All true Americans celebrated the one hundredth anniversary of

"The Star Spangled Banner,"

"written by Francis Scott Key, September 14, 1814. 1914

"The land of the free' also remembers with

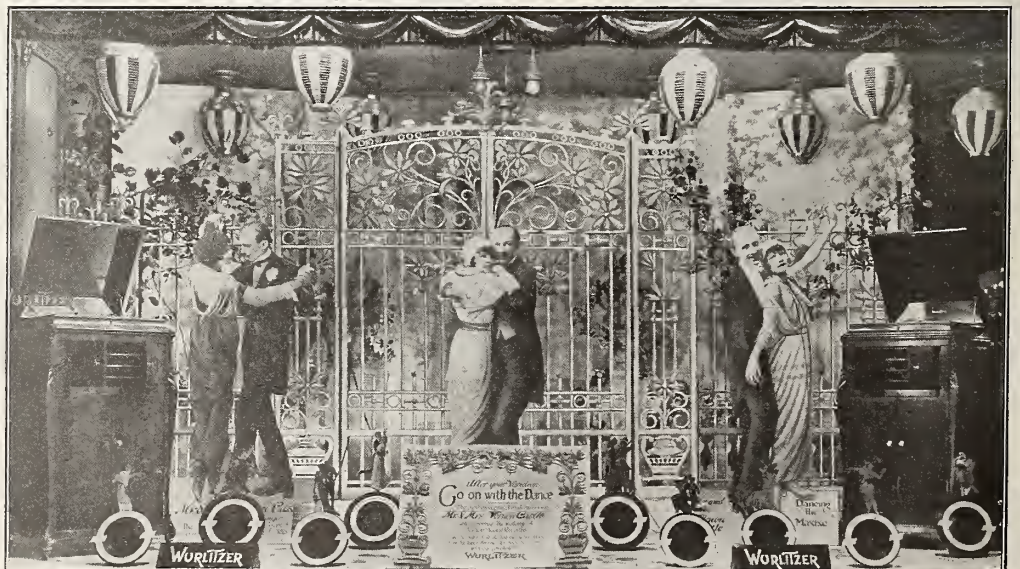

Fig. 3—Utilizing Effective Publicity for Effective Window Display.



All the way from the announcement on the front cover to the new Columbia Grafonola "Leader" on the back, the Columbia Record Supplement for November is as sure a money-maker as the mint.



(Write for "Music Money," a book "full of meat" for those dealers interested in quick and frequent turnover of capital.)

Columbia Graphophone Company
Woolworth Building, New York

An Effective Dance Display.

In the dance display (Fig. 3) I have made use of the Victor Co.'s advertisements. For some time the Victor Co. has featured Mr. and Mrs. Castle in the daily papers, illustrating the different dance steps introduced by these clever dancers. These dance pictures gave me the idea for this display. The background consisted of a large gate well adapted for window display purpose, from a classic Italian design, and made of heavy cardboard, reinforced at the back with wooden strips so as to be self-supporting. It was colored by airbrush and stood out in strong relief. This gate, which I have named "The Prunella," may now be obtained in Chicago by dealers for window trims. The life-sized figures of the Castles were made from photographs enlarged to the proper size by the "solar print" process and tinted in natural colors. On the bottom of the figures were signs with the names of the dances: Tango, Hesitation and Maxixe. The lanterns in American colors were obtained in a 10-cent store. The copy of the sign in the center read as follows: "After your vacation. Go on with the dance. The great exponents of modern dancing, Mr. and Mrs. Vernon Castle, now supervise the making of Victor dance records. Come in and get illustrated instruction book, 'How to Dance the One-Step, Hesitation and Tango,' with our compliments—Wurlitzer."

Ten dance records and two fine Victrolas completed the display—one of the most effective I have ever designed. It certainly seems easy for Victor dealers to get ideas for displays. The splendid and high-class pictorial advertising done by the Victor Co. offers new and timely sugges-

tions to the wide-awake dealer. The Voice of the Victor, their house paper, has contained for the last few months a number of well-written illustrated articles on how to get up inexpensive window displays. Full information about Victor artists' concert tours and many other useful hints for Victor display purposes are printed, so there seems no excuse for Victor dealers not to have what, in my opinion, is the greatest aid to a dealer, well-dressed and interesting show windows.

Displays for National Holidays.

Decorate your windows on all national holidays. A few American flags and appropriate records on such occasions are always in good taste. No other flag lends itself better for decorative treatment than the Stars and Stripes.

It is a good plan to have a list of special display occasions and then get busy two weeks before the date of the display. It is rather unpleasant to be reminded of a display date in your competitor's window. I would suggest the following list:

Opening day of new records, Washington's Birthday display, Valentine display, St. Patrick's Day display, Easter, Decoration Day, Fourth of July, Vacation display, School record display, Opening of grand opera, Thanksgiving display, and Christmas display.

There is, however, one rule that should never be lost sight of and that is that whenever you use window effects such as flags, flowers, ribbons, and all those things which the holiday season gives an excuse for, always remember that after all these are to be used only as a means of attracting attention to the goods. They must not be permitted in any possible way to over-

shadow or obscure the goods you have for sale.

Price Tickets and Show Cards.

Some dealers refuse to put price tickets on their instruments. There really seems to be no sound reason for not using a neat, well-written price card. Men, especially, like to see prices on goods before entering a store. I consider price tickets as one of the things that make a display interesting. Nearly all newspaper ads contain prices. Why not the show window?

Use good sign work. It does not pay to spoil an otherwise well-dressed window to save a few cents and get a cheap looking display. If you use a number of show cards have the general appearance of them alike no matter if the sizes differ. In wording show cards use the simplest and most direct language at your command. Be brief and to the point, and don't get your facts complicated with big words. Avoid slang and poetry. The science of window trimming consists not alone in attracting the attention of those with whom a dealer wishes to do business, but in attracting pleasantly and in making a favorable impression.

"BUY-A-BALE-OF-COTTON."

The "Buy-a-Bale-of-Cotton" plan has met with generous response all over the country, and without doubt this move will have a beneficial effect upon trade conditions in the South.

To our several friends in the South who have written urging our support of the movement we would say that the editor of The World purchased his bale of cotton by wire from J. N. Swanson, of the Houston Talking Machine Co., Houston, Tex.

The DITSON Pledge

is to see that our clientele has a better service than ever—setting a new standard in Victor jobbing deliveries. The demands of alert Victor dealers—the kind that grow—are many and varied, and we furnish the "first-aid" in every instance.

We believe this year's Victor business will be of tremendous proportions, and it will pay you to have

The Fastest Victor Service

which is a requisite in this hustling age. We possess the largest stocks, the best organization and most up-to-date equipment in the Eastern half of the country.

This covers Victor machines, records and supplies of every kind.

Will you let us tell you more about Ditson co-operation? A postal gets this information!

OLIVER DITSON CO., Boston, Mass.

NOTE THE NEW ADDRESS:
CARLISLE BUILDING, 19-25 E. 24th ST., NEW YORK, N. Y.

BENJ. SWITKY

NOW IS

The Only "ONLY" Victor Distributor
IN NEW YORK

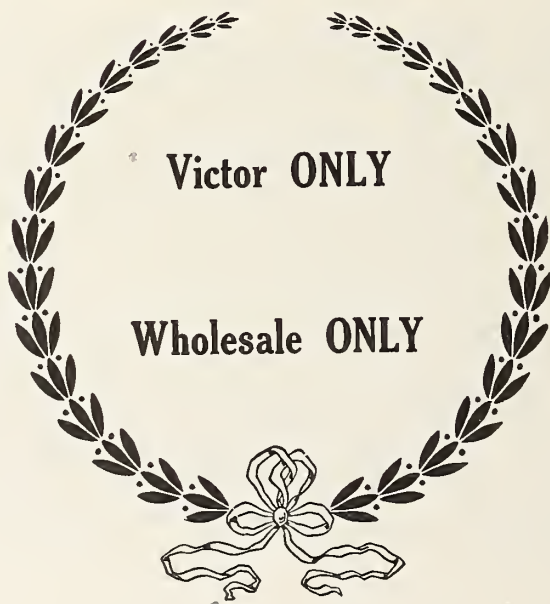

Several Distributors handle the Victor line ONLY. One Distributor sells wholesale ONLY. But BENJ. SWITKY is the ONLY Distributor who combines both qualifications.

*We sell wholesale ONLY, and handle nothing besides
Victor Talking Machines, Records, and Supplies!*

BENJ. SWITKY - - VICTOR SPECIALIST

CARLISLE BUILDING, 19-25 E. 24th STREET, NEW YORK, N. Y.

Telephone Madison Square 7531-7532.

NOTE THE NEW ADDRESS:
CARLISLE BUILDING, 19-25 E. 24th ST., NEW YORK, N. Y.

BENJ. SWITKY'S

New Policy Appeals to YOU, Mr. Dealer!

Appreciation of your liberal patronage, a desire to merit your continued good-will, and further proof of our friendship for you, prompt us to cease being your competitor in the retail field.



You are cordially invited to visit our New Quarters. They are spacious, up-to-date, accessible—in fact, selected for speed and comfort.

*Come! Let us talk over your plans
for a successful business this season.*

BENJ. SWITKY - - VICTOR SPECIALIST

CARLISLE BUILDING, 19-25 E. 24th STREET, NEW YORK, N. Y.

Telephone Madison Square 7531-7532.

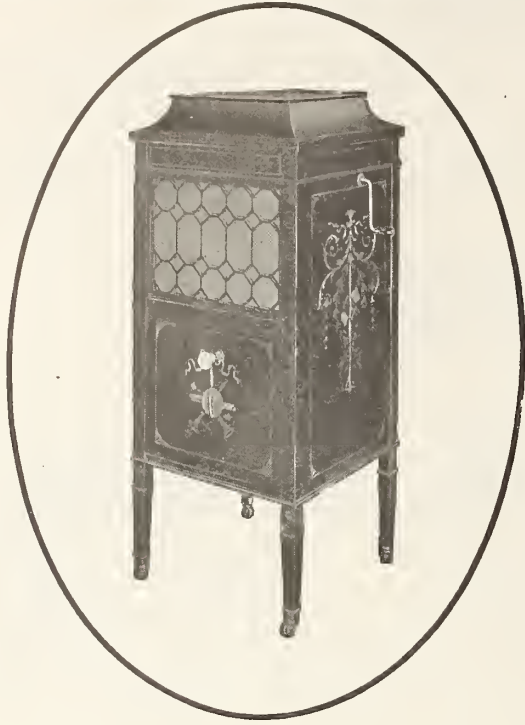
**SHERATON**

Model A290, Mahogany, Inlaid Marquetry, \$290.00

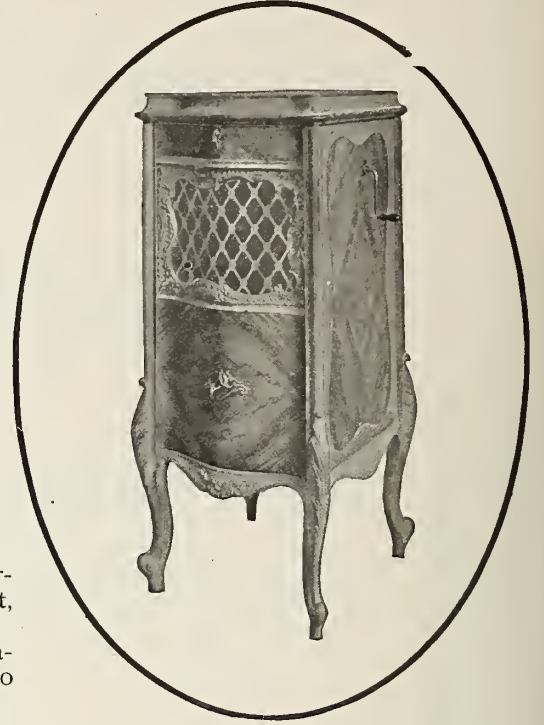
**LOUIS XV**

Model A425, Circassian Walnut, \$425.00
Model A375, Mahogany, \$375.00

Spell Binding and Sales Binding

You do not have to be an orator to sell the Edison Phonograph. It contains in itself all the eloquence needed to convince the customer that here is the musical instrument which he must have for his own.

Dealers who handle the full Edison line

will tell you that the Edison Phonograph is easy to sell because it is so easy to listen to. The minute you begin to play an Edison Phonograph for a customer the Edison inventions and all that the name Edison means in the phonograph world, are at work to bind your sale.

Thomas A. Edison, Inc.,



Model A250, Mahogany and Oak, \$250.00



Model A150, Mahogany and Oak, \$150.00



LOUIS XVI
 Model A450, Cir-
 cassian Walnut,
 \$450.00
 Model A400, Ma-
 hogany, \$400.00



SHERATON
 Model A275, Ma-
 hogany, Inlaid
 Plain, \$275.00

There's the fact that the Edison repro-
 duces those elusive overtones that the
 others miss. There's the tremendous ad-
 vantage of the permanent point that ends
 at once all needle troubles. There's the
 steady pitch that comes from the smooth-
 running motor, the indestructibility of
 the records, the beauty of the cabinets,
 all working on the customer's buying
 instinct for your profit.

So much the Edison does for itself. But
 when it has won conviction then comes
 your part of the sale. You must be ready
 to supply the convinced customer with
 the type of Edison that best suits his
 needs. And to do this you must carry
 the full Edison line, otherwise you will
 be forced to watch his conviction of
 Edison superiorities find its proof in
 some other store.

59 Lakeside Ave., Orange, N. J.



Model A200, Ma-
 hogany and
 Oak, \$200.00



Model A300, Cir-
 cassian Walnut,
 \$300.00

The **TALKING**
For the makers & sellers of talking machines
MACHINE
WORLD

EDWARD LYMAN BILL, - - - Editor and Proprietor.

J. B. SPILLANE, Managing Editor.

Trade Representatives: **GLAD. HENDERSON, C. CHACE, L. E. BOWERS, B. BRITAIN WILSON, A. J. NICKLIN, AUGUST J. TIMPE, L. M. ROBINSON.**

Boston: JOHN H. WILSON, 324 Washington Street.
Chicago Office: E. P. VAN HARLINGEN, Consumers' Building, 220 South State Street.
 HENRY S. KINGWILL, Associate. Telephone, Wabash 5774.
London, Eng., Office: 2 Gresham Buildings, Basinghall St. W. LIONEL STURDY, Manager.
Representatives for Germany and Austria: VERLAG NEC SINIT, Berlin C. 19, Ross-Strasse 6,
 Germany. GEO. ROTHGIESER, Director.
 The Talking Machine World has regular correspondents located in all of the principal cities throughout America.

Published the 15th of every month at 373 Fourth Ave., New York.

SUBSCRIPTION (including postage), United States, Mexico, \$1.00 per Year; Canada, \$1.25; all other countries, \$1.75.

ADVERTISEMENTS: \$3.00 per inch, single column, per insertion. On quarterly or yearly contracts a special discount is allowed. Advertising pages, \$100.00.

REMITTANCES: should be made payable to Edward Lyman Bill by check or Post Office Money Order.

NOTICE TO ADVERTISERS.—Advertising copy should reach this office by the first of each month. By following this rule clients will greatly facilitate work at the publication headquarters.

Long Distance Telephones—Numbers 5982-5983 Madison Sq.
 Cable Address: "Elbill," New York.

NEW YORK, OCTOBER 15, 1914.

EVERY business man should see to it that he is contributing to the best of his ability to the maintenance of trade stability. Business expansion can be accomplished when there is strength and concentrated power behind the move.

Most of our troubles are largely mental, and if men permit themselves to get into a frame of mind so that they indulge in pessimistic thoughts over business, there are ninety-nine chances out of every hundred that they will succeed in undermining their trade opportunity. A pessimistic condition of the mind foredooms men to defeat. They start in handicapped, and they stand no show of winning the race against an optimistic competitor.

We should have faith in the business future, and faith in this country's ability to meet all demands made upon it from every part of the world—faith in its ability to produce prosperity for a hundred million Americans.

The attention of our people is perhaps too much diverted to the European war, when it should be directed to the development of our own business affairs.

Through the concerted action of American business men the benumbing conditions which followed the first declaration of war is gradually being overcome and the alert Americans, manufacturers and merchants are forming a line which cannot be easily turned backward by any outside competitive forces. They are awakening to the unparalleled business opportunities that are now knocking—yes, pounding—at their doors.

It is but natural that our people should have been somewhat dazed by the sudden outbreak of events which were considered impossible in Europe and that their business affairs should have seemed for the moment commonplace and unimportant.

The quick and rapid events of the war have held them transfixed, as it were, but it is high time that business men should break away from war influences.

Most men realize the great part that Americans play in this greatest of all world battles—the role of readjusters, builders, creators of the conditions that are to rule in the days to come.

When the end of this last great war comes, and the roll-call is again read at the workshops, a million—yes, perhaps many more—will be missing, and for these the call of the unfinished tasks will be sounded no more through the long courses of the sun! The world needs workers to take up their tasks—workers to carry forward the banners of service. Therefore, Americans should see to it that they heed the imperative call to duty in the industrial campaigns which must again build up the fabric of civilization.

With our magnificent resources, the opportunities which are

opening before us become incalculably vast, and the live American manufacturer will seek to make the best use of the commercial opportunities offered by the present European situation, by wedging his way into the various markets of the world.

IN the meantime we should attend to those duties which lie nearest to us and keep away as much as possible from war influences and discussions.

The other day the story was told us of a talking machine salesman who had a number of excellent prospects in the morning, and he lost everyone of them by commencing to discuss the war situation with his callers. It is needless to say that he was retired, and his example should be a warning to other salesmen. When a customer comes into a talking machine wareroom it is not for the purpose of discussing the various phases of the European war, and the minute a discussion is entered upon interest is lost in the product which the party came in to see. Then, as the argument continues, it may be that the tactless salesman will develop a feeling far from pleasant in the mind of the caller.

It is so easy to ruin sales and so difficult to make them that it would not be a bad plan if managers put in force a rigid rule in which the salesmen were forbidden absolutely to discuss war within the warerooms. We know of one establishment that has adopted this plan, and to our personal knowledge it has been carried out rigidly. The invariable reply of every salesman to an invitation of a caller to discuss war conditions was: "We are neutral here. We cannot discuss war conditions." It is a very excellent plan and one which is liable not only to make friends, but make business, and just now every trade organization is interested in adding to its business profits.

THIS is harvest time and the business harvest should be good, and it can be if the talking machine men work with the object in view of creating a hopeful and confident feeling in regard to business.

The cultivation of economy is not at all times good. It means restriction all along the line. We mean by that, rigid economy. Conservatism, of course, is always wise, but to cultivate in the broadest possible manner the saving idea, by giving advice to people to use extraordinary care in their expenditures, means nothing less than the curtailment of business. If we could cultivate the well-balanced side—to have people work along the same lines which they have, provided they have been reasonably successful, it would to a great extent cut out the uncertainty and it would get the depression idea out of the minds of the American public.

There is no reason why publicity methods should be abandoned in the slightest. Keen advertisers realize that advertising is a powerful force to stimulate business confidence.

Men who are on the fighting lines of business realize that it is just at such a time when the weak and inefficient retreat and abandon the field to the stronger and more aggressive business forces.

If the talking machine men fail to do their share in the publicity end of the business—fail to mold public opinion—fail to interest possible buyers, then they are not contributing as they should, by effort and example, to the maintenance of business prosperity!

ADVERTISERS in The Talking Machine World receive good returns from their investment, and the paper as a business builder is conceded to be a success.

We are in constant receipt of communications from advertisers who have tested the columns of the paper and who most enthusiastically endorse it as a creative force.

Talking machine men, as a whole, do not appreciate the advantages which The World offers them as a business-building power. It is the only paper which reaches talking machine men in every part of the country—and every part of the world, for that matter.

It is read closely and men are influenced by what they see in its columns. —

One of the leading talking machine men paid The World a high compliment in a communication when he said: "Your position has been a most difficult one on account of certain conditions which have existed in this industry; and, while all may not agree with you in your policy at all times, yet it is a fact that no one at any time could deny your absolute fairness and impartiality in dealing with the affairs of this industry."

Certainly that kind of a communication is appreciated, because we all like the approval of the men whom we respect.

Here is another communication which tells of the business-building powers of The World. It is from J. B. Ogden, of Lynchburg, Va., who says: "I am greatly gratified that I have been compelled to double the manufacturing capacity each month since I began to use space in your paper. I feel that you have very valuable advertising space. Certainly it has produced wonderful results for me."

Be a business builder—one of the live ones.

IF one can forget for a moment the awful solemnity of the present European conflict, one can run down many a grim caprice it has played with lives whose general tenor is as far removed from any practical connection with war as pole is from pole. Artists in all ages have instinctively been held as more or less exempt. So even have great political orators, leaders of their fellow citizens by word of mouth, through the proved incompetence of some of their number upon exchanging as a weapon the tongue for the sword. Witness Demosthenes.

At the outbreak of this war the whole elaborate fabric of theatrical life, for instance, crumbled like a house of cards. On Saturday, August 1, the Paris Opéra was announcing "Les Huguenots" for Sunday night, with "Faust" and "Lohengrin" to follow later in the week. Saturday at midnight mobilization began. By Sunday noon "Les Huguenots" was called off and the Opéra, which is supposed to remain open all the year round, closed its doors till further notice. Too many of the personnel had been summoned to arms to make even the Sunday night performance practicable. The next day the Comédie Française followed suit. In other capitals the experience was similar.

Eugène Ysaye, the king of violinists, has been reported anxious, in spite of the exemption his fifty-six years give him, to follow his three sons into battle. What tragic irony if he should encounter on the field Fritz Kreisler at the head of his Austrian company! Could Kreisler avow himself vanquished in arms as frankly as he has in are by the greater Belgian? Georges Barrère, the admirable first flute of the New York Symphony Society, was called to the defense

of France, but was excused, and is now in New York. That charming pianist, Camille Decreus, is now on the firing line. Many an American orchestra will lose men, and perhaps here and there a leader, and many a musician may have made this last record for a talking machine.

NO one trait has contributed more to the success of America in the domain of invention and manufactures than the use of initiative and the complete abandonment of incense offering to that bugaboo, "Precedent." The development of ideas in European countries has been greatly retarded by this stumbling block, this rock in the road of progress—precedent. Those who live by precedent still live in the atmosphere of the dark ages. Because our fathers did so and so is no reason for our doing it. Modern business conditions demand initiative qualifications on the part of business men who would compete successfully, or at least willingness to initiate modern, progressive methods.

Egotism and self-sufficiency are good qualities to brace us up in the competitive struggle, but they must not chain us to the post of precedent or blind our eyes to the necessity of keeping abreast of the times. As L. M. Hattenbach says we must cast precedent aside and move with the procession, float with the tide, and sail with the wind. Otherwise we will soon find ourselves alone, stranded on the desert island of precedent while our progressive competitors are basking in the sunlight of success on the shore of progress.

THIS is the day of broad methods in merchandising. The most successful men in the talking machine or any other line are those who realize that all the factors that go to make a business establishment, whether large or small, are dependent one upon the other. They recognize that no one can be successful alone, that the proprietor must depend upon his department heads and the department heads on the salesmen—that the entire force, in fact, must work together in the mutual interests of the entire establishment. And where co-operation between all the various factors is cordial and complete, and where each factor is made to feel that he in his way is responsible for the success of the whole, then victory is bound to be achieved.

Make Two Profits on Every Talking Machine Sale



Udell cabinets are made to fit the following disc talking machines

EDISON VICTOR COLUMBIA

Udell cabinets fit each machine in style and finish. Wherever possible we follow the "lines" of the instrument—thus insuring a perfect match.

Back of each Udell cabinet is the Udell guarantee. It means satisfied customers. Write for new booklet No. 45 to-day.

OUR New Booklet No. 45 which is now ready to come to you shows you how to make a *double profit* on every talking machine you sell—*one profit* on the instrument itself—*another* on a handsome Udell cabinet to *match* the instrument.

Write for this booklet.

Every customer who buys a talking machine wants a handy cabinet for filing the fragile records and holding his machine.

Show him UDELL cabinets, which *exactly* match standard instruments in style and finish, and make an *extra* sale.

Udell cabinets are made in eight styles which dealers have found from long experience to sell best with their customers. Six of these styles, like No. 1417, shown at the left, come with either perpendicular or horizontal shelves for filing records. Two have only perpendicular filing shelves.

Christmas will soon be here, and with it the best "talking machine season" of the year. Prepare to make the most of it by having Udell disc record cabinets on your floor. Get this *double profit*. Write for New Booklet No. 45, which pictures and describes the Udell line, *now*.

THE UDELL WORKS, 1205 W. 28th St., INDIANAPOLIS

THE TRADE IN BOSTON AND NEW ENGLAND

JOHN H. WILSON, MANAGER, 324 WASHINGTON STREET, BOSTON, MASS.

(Special to The Talking Machine World.)

BOSTON, MASS., October 10.—The local trade is looking up considerably, and that dealers have been anticipating a big fall business is evident from the changes, enlargements and general improvements in warerooms all about the city. Most of the houses have large orders in for Edison, Victor or Columbia goods, and in some cases for all of them collectively. In most cases only a proportion of the orders can be filled, as the factories are overrun with a universally large demand from all over the country, a very good sign, truly. The most important piece of local news is the installation of an immense Edison exhibit at the big Domestic Science and Pure Food Exposition at Mechanics building, which is treated separately in this issue.

Business Ahead of a Year Ago.

The Pardee-Ellenberger Co. is reported by Manager Silliman to be way ahead of this time a year ago, and the trade throughout New England is pretty evenly distributed. All the company's traveling men are out, and Mr. Silliman says he looks for a big season from now on. Mr. Silliman's son, Horace H. Silliman, who has done excellent work during the summer demonstrating the Edison disc machines at the leading summer resorts along Narragansett Bay, has begun his studies at Harvard University.

Bold Burglars Get Away with Victrola.

Three music-loving burglars made a haul in North Cambridge a while ago when they broke into the music store of W. E. Moore on Massachusetts avenue and stole a handsome Victrola and a bunch of choice records. They boarded a Boston-bound open trolley car at 2 a. m. and set up their Victrola between the seats with some difficulty, yet their actions never aroused the least suspicion until an officer, who had learned of the break, saw the men going off in the car. As the officer was unable to get the car to stop the men got away with their musical plunder, and the last seen of them was when they left the car at Central Square.

Swamped with Orders.

Manager Arthur Erisman of the Columbia Co. has been over in New York conferring with the home office with regard to new business, for he has been so swamped with orders that he has not been able to get the requisite amount of goods, and it was to make strenuous overtures for a large consignment before the middle of October that took

him over. Mr. Erisman reports that the prospects look well for a banner year, far beyond that of 1913.

Henry Tosti Russell with Columbia Co.

One of the latest acquisitions to the Columbia forces is Henry Tosti Russell, a capable and versatile young man and son of Henry Russell, manager of the Boston Opera Co. Mr. Russell, who can speak several languages and has a familiarity with others, has been placed in charge of the foreign language department of the Columbia, and already he has made some valuable associations with leading schools about the city.

New Quarters for Conclave Co.

On Oct. 1 the Conclave Phonograph Co., which has been located at 9 Portland street, near the North station, has moved to a more uptown location at 46 Cornhill, where it will keep as usual a full line of talking machine records and will be open evenings.

Pictures of President and Cardinal.

The show windows of the Eastern Talking Machine Co. are adorned now with two large oil paintings which are attracting considerable attention. One is that of a full-length portrait of President Wilson, and in front is an indorsement of the Victor line of goods. In the other window the gorgeous vestments of Cardinal O'Connell call attention to the artistic full-length portrait of this Roman Catholic prelate, also with his opinion of Victor goods, of which he is a generous purchaser. His palatial Granby street residence contains a high-priced Victrola with many records.

Since the Eastern Talking Machine Co. opened up its newly equipped third floor it has found it necessary to take on extra help, and not only have extra clerks been added there, but the company has had to add to the shipping force of the establishment. Manager Taft is among the many in the trade who sees a good business ahead for the talking machine trade.

Proving Valuable Adjuncts.

Two additions to the Columbia forces in the retail department are Miss Grace Dennis and Miss Elvira Craigen, and they are proving valuable adjuncts to the department. Miss Mabelle Jones, who had to withdraw from the house in the spring because of illness, is expected back shortly after a long summer spent at her home in Maine. Miss Jones will be welcomed back, as she has proved herself most intelligent both in the demonstrating and selling of Columbia goods.

Negotiating for the Victor Line.

The Furbush-Davis Piano Co. has made arrangements with Thos. A. Edison, Inc., for handling its goods, and it is expected that the contract will be closed shortly. The Furbush-Davis Piano Co. has just opened new warerooms in Boylston street, near Arlington street, up one flight. It is the newest piano house in the city.

School Proposition Now Under Way.

The school proposition has started in well with the Eastern Talking Machine Co., and with Ed Welch in charge of this department the business promises to be very good. Mr. Welch took hold of this work when Billy Fitzgerald was advanced to the wholesale department, and he has thus far made a good record.

Good Start for the Fall Trade.

Manager Batchelder of the Victor department of the Henry F. Miller Co. reports a good beginning to the fall trade. A decided change set in immediately the surface of Boylston street was completed and the cars again began running. It is hoped this thoroughfare is now completely finished following the two years' interruption to business incident to the subway construction.

Visits Boston on Way to Pacific Coast.

George W. Lyle, the general manager of the Columbia Graphophone Co. at New York, was a visitor to Boston yesterday and the day before. Mr. Lyle was anxious to get over to Boston before going on his eight weeks' trip to the Pacific Coast, on which he will start soon. Mr. Lyle was much gratified at the business of the company on this end.

Automobiling to the White Mountains.

Edward D. Easton, the president of the Columbia Graphophone Co., is expected in Boston shortly, following his custom for the past two years of taking in this city on his way in his automobile to the White Mountains. Mr. Easton's route is along the Long Island Sound route through Connecticut, Rhode Island and to Boston, then on through Portland, Me., and into the mountains. His trip home will be by way of Vermont and down the Connecticut Valley.

Victrolas for Argentine Battleship.

From George Lincoln Parker's warerooms in the Colonial building there lately has been shipped seven expensive Victrolas which were sent over to the Charlestown navy yard to be installed on the "Rivadavia," the huge battleship of the Argentine Republic, which has been at the yard for

New England has nearly 10,000 square miles more than England and Wales combined, so you can see that there is sufficient territory here for an unlimited amount of Edison Diamond Disc sales. Consider, too, that the fastest selling model is the \$250 style, to say nothing of the excellent record list, and you have a wonderful money-making industry.

Real Music
At Last

We are exclusive Edison jobbers, our entire efforts being confined to the promotion of Edison goods. There is no diversion of interests and you are sure to get the closest co-operation and assistance in your business.

Ask us to-day for the entire story.

THE PARDEE-ELLENBERGER CO., Inc.

BOSTON, MASS.

NEW HAVEN, CONN.

THE TRADE IN BOSTON AND NEW ENGLAND—(Continued from page 16).

several weeks prior to starting for New York for its final equipment. These outfits were purchased by seven of the "Rivadavia's" officers, and the style of music selected indicates these officers to be men of high-class taste in music.

Pleased with Business Development.

H. A. Yerkes, the wholesale manager of the Columbia Graphophone Co., was in Boston a few days ago, making his periodic visit here. He and Manager Erisman went over the books of the local branch, and Mr. Yerkes was more than pleased with the way the Boston business has been forging ahead.

Sending in Good Reports.

Good reports continue to be heard from George Krumschied, the Columbia traveling man for New Hampshire and Vermont, and he is sending in large and frequent orders to Manager Erisman.

EUROPE IN WAR TIMES.

Joseph K. Nye, of Nyoil Fame, Returned Recently from Europe After Undergoing Some Remarkable Experiences.

Joseph K. Nye, of William F. Nye, the famous oil manufacturer, of New Bedford, Mass., was one of the thousands of American refugees who arrived in New York during the past month from Europe. Mr. Nye had some remarkable experiences while abroad, and said that he wouldn't take \$10,000 for the experience now that he had it.

There was a long interview in the New York Sun with Mr. Nye, telling of his impressions when the war started in Europe and how he at once filed a message to his business manager to buy all the European oil on the market at any price, and the fact that they would not send the cable because it had the word Russian in it. He engaged passage on the "Caledonia," but after all the passengers had gone on board, and just two hours before sailing, the Government took the ship and the passengers were all dumped on shore. Later the passengers were taken by the "Baltic," 2,990 passengers being on board a boat which ordinarily carries half that number.

There was a manufacturing concern that paid a couple of hundred dollars in wages each year to keep the brass door plates and rails about the office polished bright and clean. One day all these shining surfaces were covered with a coat of transparent lacquer such as was used in the plating room. No more tarnish; no more wages to brass polishers.

ATTRACTIVE EDISON EXHIBIT

At the Domestic Science and Pure Food Show at the Mechanics Building, Boston—Much Interest Shown in Lectures and Demonstrations of Edison Disc—Other Exhibitors.

(Special to The Talking Machine World.)

BOSTON, MASS., October 5.—The notable feature of the Domestic Science and Pure Food Exhibit at Mechanics building, which opened to-day, is the Thomas A. Edison exhibit, which occupies the interior of a big Swiss chalet erected on the large stage of Grand Hall. The exhibit is in personal charge of Harland R. Skelton, who is one of the efficient attaches of the Edison Co., and who often is singled out for special work for the company at distant points. The Swiss chalet, because of its elevated position, is most conspicuous, and the interior, which resembles a good sized hall, is filled with seats. Periodically Mr. Skelton gives talks or lectures, both on the Edison disc machines and on the moving-talking pictures which are thrown on a large screen beside his raised platform. On two sides of the room are raised platforms on which the Edison disc machines are exhibited. Outside of the Swiss chalet two other of the Edison exhibits are those of the Telescribe, which is a connection of the dictating machine, and the Transophone, each of which has a place on the floor of the hall close to the Swiss chalet.

At the rear of the improvised hall, on the stage, are several rooms, each of which is devoted to an exhibit of Edison dealers here in Boston. Those who have these individual exhibits are George Lincoln Parker, of the Colonial building; Chickering & Sons, of 169 Tremont street; the Shepard Norwell Co., on Winter street; the Shepard stores of Providence and F. H. Thomas Co., of 691 Boylston street. It is said that the Edison exhibit, which is one of the most-talked-of displays of the show, cost in the neighborhood of \$10,000.

In the parcel post exhibit the Eastern Talking Machine Co. makes an interesting showing by way of illustrating the difference between the old way of sending goods and the new one through the medium of the parcel post. A card board box shows the damages sustained in sending records improperly shipped and another box shows the modern method of packing for shipment. In the one case the records are scratched and otherwise damaged, but under the more up-to-date method there is not the slightest damage whatever, and the goods are received by the purchaser in perfect condition.



Lansing Khaki Moving Cover

is the only safe protection that you can use for wrapping machines for shipment, for it insures perfect delivery condition.

It is the same as packing each talking machine or record cabinet in four thicknesses of heavy felt, with cotton flannel on the inside to keep the varnished surfaces right, and Government khaki on the outside to insure wearing durability of the cover.

**Gives Protection Against
Dust
Finger Prints
Bruises
Scratches and
Heat or Cold**

You save all bother of refinishing each machine, so each cover saves its cost within a week after you buy it.

Place for your name and address on the outside, so you also get advertising value.

Ask us to send you a Lansing Cover and test it yourself. Also get our Booklet No. 6 giving you full details.

Better send for these to-day.

E. H. LANSING
611 Washington St.
BOSTON, MASS.

The largest manufacturer of Talking Machine Needles is located in the United States

To be exact, the plant is at Lowell, Mass., one of the biggest manufacturing cities of the country. It was in 1870 that the needle business of W. H. Bagshaw was established, and the first talking machine needles were made by him. The business has steadily grown, until our shipping record reached the tremendous number of over 63,000,000 needles in 10 days, and even then our capacity was not taxed to its extreme. Every needle a Bagshaw-made quality needle—which means the best in the world at any price.

W. H. Bagshaw, Lowell, Mass.

Pioneer Maker and Largest Manufacturer of Talking Machine Needles



The Columbia Educational Department is better prepared than ever before to help you secure school business in your locality. Now is the time to go after it.

Right now is a remarkably appropriate time for you to write us for particulars.

(Write for "Music Money," a book "full of meat" for those dealers interested in quick and frequent turnover of capital.)

**Columbia Graphophone Company
Woolworth Building, New York**



DETROIT DEALERS WELL STOCKED UP FOR HOLIDAYS.

Have No Misgivings Regarding Future Business Conditions—Increasing Facilities for Storing Records—Grinnell Bros. Developing New Salesmen—Columbia Line for Cable Piano Co., Stores—What the Various Local Houses Have to Report—Personals.

(Special to The Talking Machine World.)

DETROIT, MICH., October 9.—The Detroit talking machine stores are all pretty well stocked up for the holiday trade, having begun to attend to this important matter shortly before the Fourth of July, and there is nothing in sight but big business and optimism. Evidence grows everywhere that the talking machine is a commodity of just about the right price and attractiveness to sell whether any other kind of merchandise is selling or not. Even the best of them do not create a big liability if purchased on time, so there is nothing to frighten people who want them.

In addition to big stocks of machines nearly all the dealers are enlarging their record racks, a circumstance which, not important in itself, tells an important story, for all the stores have astonishingly large record racks now and wouldn't increase them unless there was a very good reason.

Several of the stores have increased their sales forces also. Grinnell Bros. have put on half a dozen additional outside salesmen bringing their sales force in the talking machine department up to thirty-one, exclusive of manager and office force. That gives an idea of how really active the Victor talking machine business is in Detroit.

When Grinnell Bros. add new salesmen to their talking machine staff they select men from other lines of business, desiring to train them in the talking machine field according to their own system. It is a pretty big job to develop an expert salesman, but it pays better than obtaining an experienced one from elsewhere, who may be very good, but may have ideas not in harmony with the Grinnell organization. The new men are kept in the store several weeks, learning the ropes thoroughly before being sent outside.

With Grinnell Bros. the last week in September

was the biggest week since last Christmas, and September was comfortably ahead of the same month of last year. In Detroit the demand still runs to the higher priced machines. This trend has been so persistent for the last two years that it has become accepted as permanent, and few if any machines of a lower price than seventy-five dollars are kept on the floors. The story is the same in all the downtown stores, though in the suburban stores, especially in the vicinity of the various foreign sections, there still is a call for the cheap machines.

The talking machine department of the J. L. Hudson Co. has added to its staff of salesmen Joseph J. Rogers and Harold Ballagh, both of whom formerly were salesmen with the American Phonograph Co., Edison jobbers in Detroit. They resigned their positions last spring to go abroad, and were in Europe when the big war broke out. Fate chased them from one country to another, keeping them out of the way of the armies, until finally they turned up at an Italian seaport and obtained passage for home. They arrived in Detroit only a short time ago.

The Columbia branch store is busy with both wholesale and retail trade. Sales Manager S. E. Lind recently sold complete lines to the Jackson and Battle Creek branches of the Cable Piano Company of Detroit. The Jackson business is still on the books of the Detroit Columbia store, but the Battle Creek store is in Chicago territory, and had to be turned over to the jurisdiction of that city. However, Mr. Lind does not care, as long as the store keeps on handling Columbias.

September was ahead of last year's September, according to the stock-taking account, though the exact figures had not been completed when the Talking Machine World man called. In the Co-

lumbia store there is a taking of stock on the first of every month, so that a constant tab is kept on the condition of affairs. This policy is especially valuable in keeping the stock of records up to the minute. The Columbia store, being a wholesale institution, keeps an unusually large stock of records. In spite of this, racks now are being built which will care for an increase of one-third.

A feature of the record trade with the Columbia is the call for patriotic records, such as the national airs of Germany, France, England and Russia.

Frank J. Bayley, who handles the Edison, reports that the \$200 and \$250 styles of the Edison sell the best. He confines his stock almost exclusively to these machines.

Max Strasburg, of the Max Strasburg Co., was in Grand Rapids this week as a member of the Detroit Rotary Club. The Detroit club has been invited by the Grand Rapids Rotary Club, along with the Rotary clubs of Saginaw and Bay City, to attend an important function of the organizations in Grand Rapids, and so many members accepted that a special train of parlor cars was necessary to transport them.

J. Henry Ling, head of the oldest piano house in Detroit, has decided definitely to establish a talking machine department, but his plans have changed since he first took up the idea a month ago. He will not be prepared to announce them until next month.

COMER TALKING MOTION PICTURES.

(Special to The Talking Machine World.)

CHICAGO, ILL., October 10.—The Comer Talking Motion Picture Co. has been incorporated with the Secretary of State of Illinois with a capital of \$10,000 by John J. Comer, Frank Mayer and Guy Van Schoick for the purpose of leasing, operating and dealing in sound reproducing apparatus, motion picture projectors and films.

Optimism and opportunity make a fine alliterative combination.

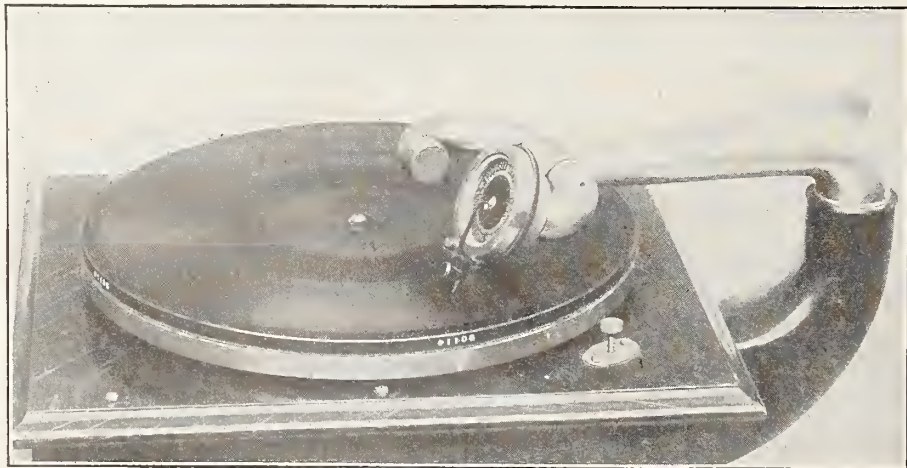

**DO YOU WISH
TO PLAY
EDISON DISCS?**

Price \$2.00

(Sample to Dealers \$1.00)

LEXTON SPECIALTY CO., 216 West 99th St., N. Y.

We “Dote” on “Shorts”

YES sir! We like to get orders for Victor goods other jobbers are “short” on. If you’re having trouble getting your orders filled, TRY US—for if anybody in the country has a complete stock, WE have!

Take Records, for instance. Everybody tells us we fill Record orders more completely than any other house in America. Lots of big dealers send us their “short” orders only—and we’re glad to get the business.

If your regular Victor jobber can’t fill certain items in your list, ask us to do it.

Send us the orders others can’t fill.
We just “dote” on “shorts.”

Koerber-Brenner Company



Victor Distributors

Saint Louis



Harry G. Koerber
President & Treasurer

Edwin C. Rauth
Vice-President & Secretary

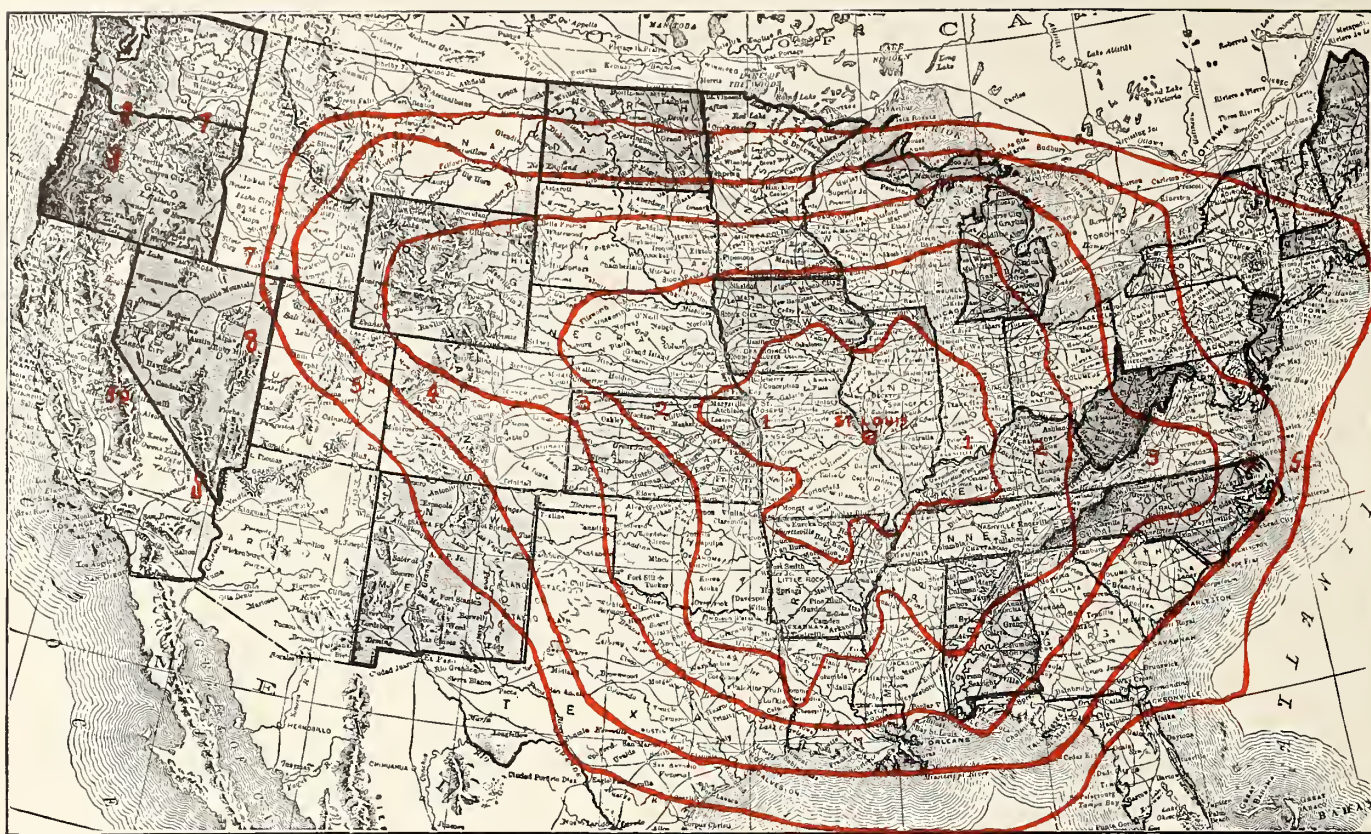

Saint Louis— Shipping Center

IT'S mighty important to you—the fact proven by the map above.

Saint Louis, shipping center of the United States, sends out daily over twelve hundred package freight cars—routed by fast freight and arranged to break bulk at destination. The circles about Saint Louis on the map show when these cars arrive—each circle representing one day from Saint Louis.

If we can send freight this fast—think how much faster we ship by express and parcel post!

Saint Louis is at **YOUR** door.

And in Saint Louis is the **BIG** Victor Stock—so big a stock that if anybody in the country can fill your “shorts” we can.

From the shipping center of the country, we are able to deliver with utmost speed.

Koerber-Brenner Company



Victor Distributors

Saint Louis



Edwin C. Rauth
Vice-President & Secretary

Harry G. Koerber
President & Treasurer

A Great Combination!

For

VICTOR DEALERS

Salter's Trade Maker, No. 19

This Cabinet will put "pep" and "ginger" into your sales instantly. It gives the appearance, effect and service of an expensive Victor-Victrola, and cuts the price in half.

You don't have to be a Sherlock Holmes to figure out its sales possibilities. Cabinet No. 19 and Victrola No. 9, as illustrated, make a wonderful combination.

Show Them Together and A Sale Invariably Follows

The cabinet is built to match, and it harmonizes in every detail with the machine itself. A counter-sunk top holds the machine firmly in place. The felt-lined compartments insure the owner of valuable records against their damage by scratching, warping, etc.

This and other practical, low-priced Salter Cabinets will draw a lot of *new trade* to your store. *Write to-day* for catalogues, folders, prices and full information, and rush your fall and holiday orders.

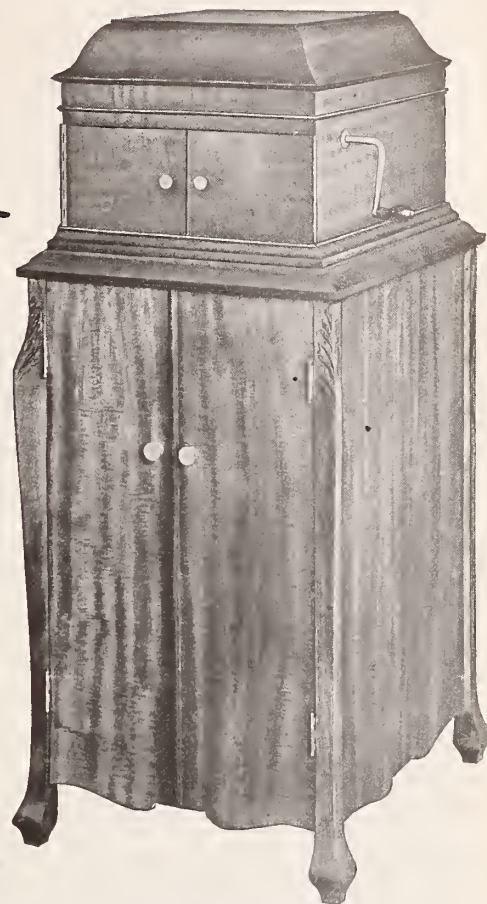

**SALTER CABINET
No. 19
With Victrola IX**

SALTER MFG. CO.
339 N. OAKLEY BLVD.
CHICAGO

RE-ENTERS THE WHOLESALE FIELD.

Al Edelstein to Cover Metropolitan District for Benj. Switky—Well Known in Trade.

Al Edelstein, wholesale salesman for Benjamin Switky for several years and more recently connected with the Switky retail store, has again entered the wholesale field with Mr. Switky, follow-



Al Edelstein.

ing the sale of his retail business by the latter. Mr. Edelstein has a large acquaintance among the Victor dealers in the metropolitan district and is very popular as a salesman. His experience in the wholesale field has impressed him with the opportunities in that department of the business, especially under the new conditions, and he takes up wholesale work again with renewed energy and optimism.

Associated with Mr. Edelstein in the Switky wholesale department will be Henry Kogan, who has been with Mr. Switky for some time and has met with much success.

More dangerous than a little knowledge is much knowledge of things that aren't so.

PARKER AS A LIVE WIRE.

How the Ft. Meyers, Fla., Dealer Concentrates the Attention of the Purchasing Public of His Locality to the Fact That He Was Appointed a Columbia Representative.

(Special to The Talking Machine World.)

ATLANTA, GA., October 6.—Among the many recent new accounts signed up by the local wholesale headquarters of the Columbia Graphophone Co. was that of J. B. Parker, of Ft. Myers, Fla., who conducts a rapidly growing business in that city. To announce his acquisition of the Columbia line Mr. Parker used a rather unusual advertisement that attracted considerable attention, and what is more important, produced gratifying results.

This advertisement took the form of a letter addressed by the Columbia Graphophone Co., of New York, to the music loving people of Lee County, Fla., wherein Ft. Myers is located, advising them

that J. B. Parker, its representative in that territory was carrying a full line of Columbia products, and extended them a cordial invitation to visit his establishment to hear any Columbia machine or Columbia records which they may care for. The personal element in this advertisement created a feeling of confidence which has aided Mr. Parker in the development of an extensive Columbia clientele.

REX SALES CO. ORGANIZED.

The Rex Sales Co., Philadelphia Pa., has been incorporated, with capital stock of \$100,000, for the purpose of selling or disposing of talking machines and records. The incorporators are A. G. Trout, J. R. Friedman and A. G. Walsh.

The Ario Sales Co. has opened sales rooms at 228 Tremont street, Boston, under the management of James Ashton Reid. This concern will handle phonographs of popular price.

Your Opportunity

50 cents stamps brings you a sample of our highly perfected Standard Fibre Needle Cutter. 25 cents stamps brings you a sample of our simple and accurate Standard Automatic Stop.

Samples sent only to bona fide dealers writing on their business letterhead. Place regular orders through your jobber.

STANDARD GRAMAPHONE APPLIANCE CO.
173 LAFAYETTE STREET NEW YORK



Tone *plus* tone control comes as near as ever you will get to a nut-shell definition of what the Columbia is offering and what Columbia dealers are wanting.



(Write for "Music Money," a book "full of meat" for those dealers interested in quick and frequent turnover of capital.)

**Columbia Graphophone Company
Woolworth Building, New York**

NOW READY FOR AMERICAN MARKET.

Pathé Frères Phonograph Co. Makes Long Expected Announcement to the Trade—Has Been Busy Perfecting Manufacturing and Sales Organization—Details Regarding the Line Offered and How It Will Be Distributed.

The Pathé Frères Phonograph Co., 29 West Thirty-eighth street, New York, is advising the trade throughout the country that it is now ready for the American market. For the past two years this company has been perfecting every detail of its



Leo Slezak Recording for Pathé Frères Phonograph Co.

manufacturing and sales organization, and in making its first announcement the company does so with the knowledge that it has carefully considered every phase of the industry and arranged plans whereby dealers throughout the country may handle its products on a profitable and satisfactory basis.

Pathé Frères hardly need any introduction to the American dealer, as this concern is the largest manufacturer of motion pictures in the world and the acknowledged leader in this field. The Pathé Frères Phonograph Co. has been doing business throughout the world, with the exception of this country, for many years, and the success it has achieved abroad well qualifies it to handle American trade with the same degree of perfection.

According to present plans the Pathé Frères Phonograph Co. will market a complete line of cabinet, hornless machines, ranging in price from \$15 to \$175, together with an adequate library of records. Shipments of both of these products have already been made to all parts of this country, and during the past few weeks arrangements have been consummated for representation in various territories.

The machines are known as the Pathéphones and the records as Pathé Discs. All the records are double-faced and reproduced by means of a smooth, genuine sapphire, which need never be changed. The Pathé Discs are now being furnished in two sizes 11½ and 14 inches, and are cut on what is known as the "hill and dale" principle. Later it is planned to issue 20-inch double-faced records.

It is announced that the method of distribution is in accord with that used by the other talking machine manufacturers, namely, through jobbers and dealers. Territory will be assigned the job-

bers appointed, who in turn will close contracts with the dealers in their territories.

A complete library of records is now being offered to the trade, including grand opera, semi-classic, popular and dance selections, together with any other class of records desired. A feature of the record library is the presentation of complete grand opera scores sung by artists of international prominence, including Slezak, Titta Ruffo, Giorgini and others.

It is stated that the war abroad has caused absolutely no delay to the company's shipments, and shipments are being received daily. The Pathé Discs include both European and American recordings, all of the dance selections being supervised by Maurice and Miss Florence Walton, two of the best known interpreters and teachers of the modern dances in this country.

The Pathéphones embody a number of distinctive features, including a tone modifier which enables the listener to have absolute control over the tone. This and other features are being fully presented to the trade in this country in the company's most recent literature.

In an interview with *The World*, an officer of the company remarked as follows: "Our jobbers and dealers need have absolutely no fear of litigation of any nature, as their and our interests are fully protected. We are planning to give our trade every possible co-operation in selling and publicity, and are now completing plans for an extensive advertising campaign on behalf of our products."

A social event of importance in the trade was the marriage, on September 24, of Miss Anna Kahn, sister-in-law to Benjamin Switky, who for some years looked after the retail sales in the Switky store at 9 West Twenty-third street, to Benjamin Rabinovitz, who is well known in the woolen trade. The wedding took place at the home of Mr. Switky and was largely attended. Miss Kahn was well known and popular in the trade, many members of which extended congratulations and best wishes.

BUSINESS IS GOOD—THERE'S A REASON

A TRIAL ORDER WILL SHOW YOU

WHY

THE GOODS AND THE SERVICE IS THE ANSWER

The DOME RECORD CASE

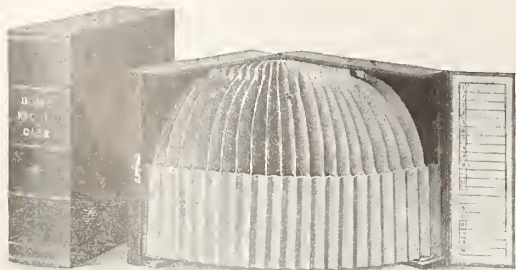

should be in your stock. Holds 20 records. Made in 10" and 12" sizes. Equipped with lock and key. Order samples to-day, with the list of records and that particular style or finish of Victrola you are unable to get elsewhere.

The completeness in filling and promptness in shipping your order will convince you we have both goods and service.

Edison and Victor Distributer

W. D. ANDREWS, Buffalo, N. Y.

For
COLUMBIA DEALERS
Salter's Trade Maker, No. 112

Everybody gets the "buy fever" when they see this handsome combination set up on your sales floor or in your window. It looks to be so much more expensive than it really is that people are easily sold when they find out the low price.

This Machine and Cabinet Match Perfectly

in design and finish. Felt lined compartments afford protection, records are easily accessible, there is a convenient filing index and many other features that simply argue their way in your prospective customer's pocketbook.

This is already a very popular combination, and the holidays will see them going like "hot cakes." Protect yourself against forgetfulness by getting out your catalogue and ordering *Now*. If you haven't a catalogue your postcard will bring one.

SALTER MFG. CO.
 339 N. OAKLEY BLVD.
 CHICAGO

A Sales Booster!

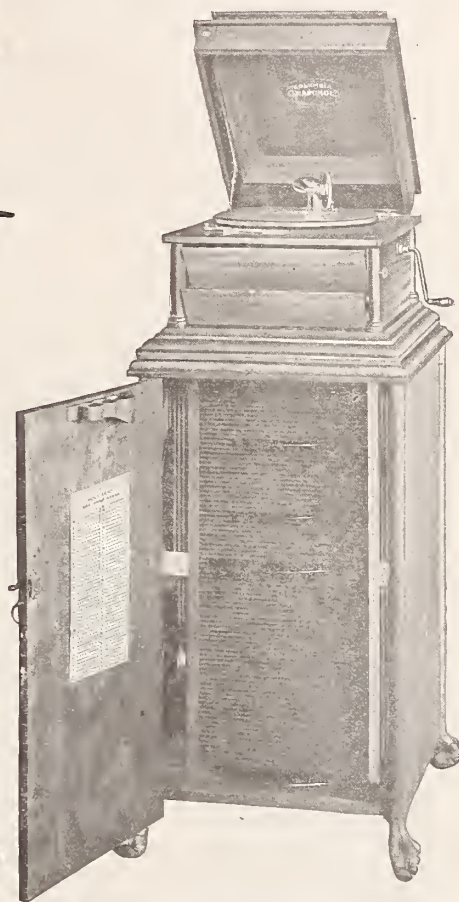

SALTER CABINET
No. 112
 With Columbia "Favorite"

REPORT BUSINESS IMPROVEMENT IN CLEVELAND.

Popularity of the Various Lines of Machines and Records—Many New Dealers for the Edison Disc Line—Grafonola Co. Takes on Line of Pianos and Player-Pianos—General Enthusiasm Regarding the Outlook for the Holidays—Interesting Personal Items.

(Special to The Talking Machine World.)

CLEVELAND, O., October 8.—Deterent influences, aside from the war, have affected general business, but apparently not so seriously the talking machine trade. Dealers report business during the past month as having been very satisfactory, considering the situation, and many schedule an increase in trade. Notably the Eclipse Musical Co., the manager stating there was a considerable increase over former months and over the same period last year, both in the wholesale and retail departments. The company is enthused with the prospects of the ensuing season, and is looking forward to the best year in the history of its business with much enthusiasm. F. E. Lane, manager of the retail department, has resigned, and his place has been filled by C. H. Denslow, who has been connected with the company for several years, as outside salesman. He is well known, popular and a first-class talking machine man.

The popularity of the Edison phonographs is increasing as is manifest at the store of The Phonograph Co., Edison distributors. L. N. Bloom, secretary, says business for September was exceptionally good. "Trade throughout the State," he said, "has largely increased. A number of high-class concerns have recently taken on the Edison disc line and are well pleased with the results already shown. We have averaged over 200 people at our four last recitals, and in the interest shown by the public in the work it is reasonable to expect a big holiday business."

Business of the most satisfactory character continues with the Grafonola Co. The company has recently added the Packard pianos and players and the Bond pianos to its line. Mr. Routh said:

"We are very much pleased with the September business, especially with the fact that payments are coming in ahead of time. Medium-priced goods are selling well, which indicates money conditions in Cleveland are easy, otherwise the working people would not be ahead with their payments, nor would we be selling to the working men. We are expecting the largest winter's business ever experienced in this store."

The H. E. McMillin & Son Co. also report business in the Victrola department as having been exceptionally good. Mr. Kellogg, manager, is well pleased with the outlook for the fall trade, and is making extensive preparations to take care of the holiday trade. The company recently received a large shipment of machines, and owing to alterations in the Victor department, was compelled to occupy the fourth floor of the building for their storage. Mr. Kellogg is much elated over the splendid results which were accomplished through the exhibition at the recent county fair, resulting in the sale of several Victrolas of the more expensive types, proving that these machines are becoming more popular with the farming community.

G. R. Madson, manager of the Columbia store, is quite enthusiastic regarding the fall outlook as foreshadowed by the inflow of present orders and accomplished results of the past two or three months. "Business is good," he stated. "We find that throughout this territory during the past few weeks business has picked up very materially and is practically normal at this time. All indications point to an exceptionally heavy holiday trade."

Recent new Columbia dealers are: C. T. Hoose, 105th street, Cleveland; W. A. Bammerlin, Mason, O.

The indication of dull times is not very noticeable at the store of the Brainard Piano Co., which claims the best equipped Columbia department in Ohio. "Our business," said Mr. Morton, manager of the department, "has suffered somewhat during the summer months, along with other talking machine people, but the past month showed a very nice increase, while, so far, this month has been quite satisfactory. We are preparing for a good business during the coming winter, and I am satisfied we will get it. Our school business is opening up in good shape, and Mr. McClelland, who has charge of this end of the business, is reaping the benefit of the hard work he did last spring and at the play grounds this summer. He also has been quite successful with many out-of-town schools, among the more important of those was a sale to the State Normal at Kent, O.

Trade is reported fairly good, and improving at the W. F. Frederick Piano Co. The outlook was said to be very encouraging. N. H. Cook, who for some time has been manager of the Victrola department, has resigned and is now with Boggs & Buhl, of Pittsburgh. Mr. Stafford, manager of the piano department, has assumed entire management of the store, and W. J. Breyer is assistant in the talking machine department.

In the talking machine department of the Collier & Sayle Co. improved trade is manifest, concurrent with the approach of the holidays. This is especially manifest in the wholesale department. Good sales of records are reported.

The B. Dreher's Sons Co. is busy in the talking machine department, as well as the piano. Mr. Bowie, manager of the Victrola department, says business is good, growing better and foreshadows continued prosperity. There is a special call for high-priced styles.

T. A. Davies, manager of the talking machine department of William Taylor, Son & Co., W. H. Buescher & Sons Co., the May Co., The Bailey Co., and other dealers are all optimistic as to the fall trade.



It may be well to remind you again that the Columbia policy is the "open shop" policy—free competition, a fair field and no favors.



(Write for "Music Money," a book "full of meat" for those dealers interested in quick and frequent turnover of capital.)

Columbia Graphophone Company
Woolworth Building, New York

RECORD OF NAVAJO INDIAN SONGS.

Latest Novelty in the Edison Catalog Made Possible Through the Efforts of Geoffrey O'Hara, Who Occupies a High Place in America as an Exponent of Indian Music.

One of the great novelties in the list of Blue Amberol records issued by Thos. A. Edison, Inc., for November, is No. 2451, devoted to Navajo Indian songs, each prefaced by an explanatory talk by Geoffrey O'Hara, that adds greatly to its interest. It is a novel and interesting record that constitutes a valuable addition to the library of every one interested in American music. The Navajo Indians have thousands of songs that have been handed down for centuries from father to son, from teacher to pupil. They have a number of ceremonies, each one lasting nine days and nights, each containing more than six hundred songs.



Geoffrey O'Hara.

Several of the best of these Indian songs were selected from a large number taken on the Edison recording phonograph. The accompanying picture shows several Indian boys making such a record. All these songs have been made a matter of special study by Mr. O'Hara, who was appointed Instructor of Native Indian Music by Franklyn K. Lane, Secretary of the Interior. He himself has learned several, and having harmonized them, is enabled to reproduce them with novel and interesting effect.

Col. Theodore Roosevelt, speaking of Mr. O'Hara's work, says: "Among the visitors at the snake dance was Geoffrey O'Hara, whom Secretary of the Interior Lane has so wisely appointed Instructor of Native Indian Music. Mr. O'Hara's purpose is to perpetuate and develop the wealth of

Indian music and poetry—and ultimately the rhythmic dancing that goes with the music and poetry. Many well-informed and well-meaning people are apt to protest against the effort to keep and develop

preserve the Indian's only as national bric-a-brac. This is not so. We believe in fitting him for citizenship as rapidly as possible. But where he cannot be pushed ahead rapidly we believe in making

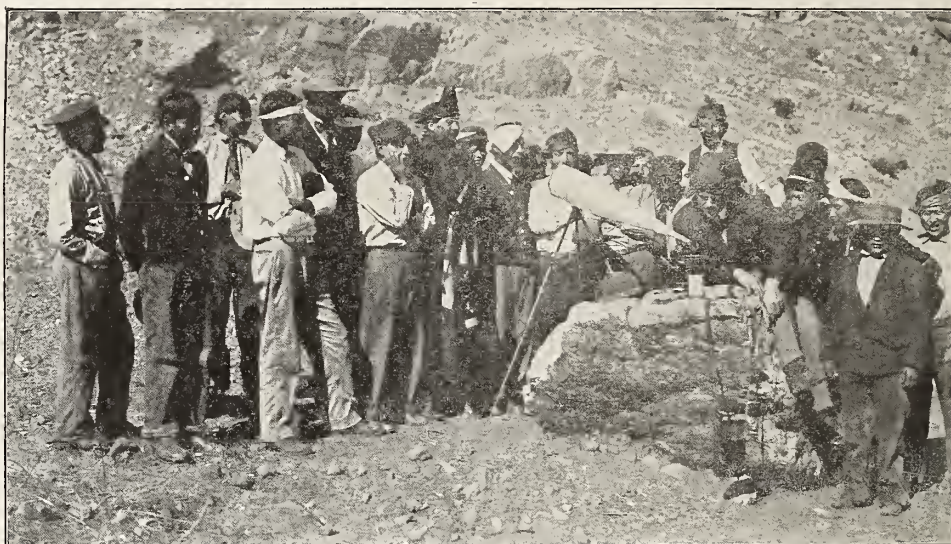

Navajo Indian Schoolboys, Fort Defiance, Arizona, belonging to the Government Indian School, singing their native Indian songs into the Edison Recording Phonograph, for Geoffrey O'Hara, Instructor of Indian Music.

what is best in the Indian's own historic life as is incompatible with making him an American citizen, and speak of those of opposite views as wishing to

progress slowly, and in all cases where it is possible we hope to keep for him and for us what was best in his old culture."

WHOLESALE TRADE EXPANDS

With Landay Bros. Since They Announced the Extension of This Division of Their Business—Expect Big Fall and Winter Trade.

Referring to their recent increase of facilities for the handling of their wholesale business, Max Landay, of Landay Bros., 563 Fifth avenue, New York, prominent Victor distributors, remarked:

"I am very pleased to state that our wholesale business the past few weeks has increased in proportion to the extension of our facilities for handling this division of our business. Our wholesale trade has taken quite a spurt recently, and I

am looking forward to a very satisfactory fall and winter trade in our wholesale department.

"Although we are signing new dealer accounts daily, and are still in a position to take care of the wants of additional dealers this coming season, we are carrying out our policy of handling only that amount of wholesale trade which we can cooperate with in every way. We wish to feel that our dealers can depend upon us to fill their orders at all times, and in addition we are placing at the disposal of our trade the results of our many years' experience as retailers of Victor products."

PARKER "AT THE FRONT."

According to advices received by his former associates in the advertising department of the Columbia Graphophone Co., New York, Henry E. Parker, who left for England last month, is now at the front fighting for his native land. Mr. Parker was sworn in as a gunner in the Royal Horse Artillery, which mobilized at Wimbledon, England, the latter part of September and which embarked for foreign service the first of the month. To quote from Mr. Parker's letter: "God and Kitchener only know where we are going."

AWAY ON SHORT TRIP.

V. W. Moody, sales manager of the New York Talking Machine Co., 81 Chambers street, New York, Victor distributor, left Friday night for a ten days' rest, which he will spend at various points in the South and West.

Make hay while the sun shines and you won't be so apt to make trouble when it rains.

"Standard" Record Cleaner

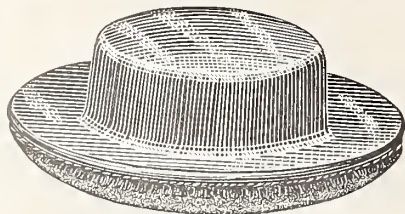

Price, 50 Cents, List
Patented June 2, 1914.

Send 10 cents in stamps for a sample cleaner. Write on your business letter head only. Place regular orders through your jobber.

ARTISTIC AND ATTRACTIVE

Grips the record surface and clings as if on rails.

Extended brush area cleans record with one sweeping circuit.

STANDARD GRAMAPHONE APPLIANCE CO.

173 LAFAYETTE STREET

NEW YORK

CHASE & WEST'S STRIKING DISPLAY "STYLE SHOW" WEEK.

(Special to The Talking Machine World.)

DES MOINES, IA., October 5.—In the parade of floats, an important feature of the very successful

by characters in costume. The Japanese summer garden setting was carefully carried out by the use of abundant natural foliage in pink and green en-

E. R. PERKINS WRITES COLUMBIA CO.

Vice-President of the Aeolian Co. Writes Complimentary Letter Anent Recent Contract to Handle the Columbia Line at Retail in Aeolian Hall and Various Branches.



Chase & West Float Which Made a Big Hit at "Style Show."

"Style Show" held in this city during the week of September 15, the Chase & West Talking Machine Co. very effectively advertised the Victrola by depicting one of the principal scenes from the opera "Madame Butterfly." Pinkerton, Homer, Farrar, Troubles and the American Lady were represented

twined over a rustic pergola and by lighted Japanese lanterns.

The float was the subject of much favorable comment, and without doubt it served to give the Victrola added publicity of value in Iowa's capital city.

The importance of the recent deal closed by the Columbia Graphophone Co. whereby the Aeolian Co., largest manufacturers of musical instruments in the world, will handle the Columbia line in New York and all its branch stores is further enhanced by the receipt by General Manager Lyle of the following letter from E. R. Perkins, vice-president of the Aeolian Co., and one of the most prominent men in the piano industry:

"Referring to contract signed by our house covering the handling of your line of merchandise and orders for product which accompanied the same, I take pleasure in advising that this action on our part was taken only after a most careful investigation as to the quality of your product and the demand which you have created for same.

"The class of merchandise which we handle made it essential that we should make no mistake regarding this matter, and a rigid test of the quality of your goods was made by our most qualified experts. The result of such investigation was the contract referred to above and we look forward with pleasure to a very substantial business with your line. Appreciating the facilities you placed at our disposal for such investigation, and assuring you of our co-operation in every way, we remain, very truly yours, The Aeolian Co.

(Signed) "E. R. Perkins, Vice-President."

George W. Lyle, general manager of the Columbia Co., left this week for his annual trip to the Pacific Coast.

A. H. Bates is now wholesale representative for the Victor Talking Machine Co. in local territory, succeeding Thomas F. Green, who resigned a fortnight since to become general manager of Silas E. Pearsall Co., New York Victor distributor.

NEW SONORA CATALOG ISSUED.

Latest Volume Illustrates and Describes Entire Line of Sonora Phonographs—Record Cabinets Also Featured—Attractively Illustrated and Printed—Most Artistic Effort.

The new catalog of the Sonora Phonograph Corp., 57 Reade street, New York, has been issued and is a volume of excellent character. It illustrates the entire line of Sonora phonographs, including the following various models: "Jewel," "Excelsior," "Peerless," "Imperial," "Baby Grand," "Rosary," "Elite," and the "Grand," with prices ranging from \$35 to \$200 at retail.

The volume is printed with brown ink on white paper and from a typographical standpoint is emblematical of great care and attention to printing detail.

An innovation in illustrating the use of the Sonora is found on opening the catalog at the center there being a number of half pages bound in, showing the extent of the repertoire which may be heard on this phonograph. In conjunction with these pictures is seen the picture of a man and his family listening to the playing of the Sonora. In the foregoing group of inserts are illustrations playing up the grand opera, foreign language, male quartet, organ, ballad, musical novelty, recitation, minstrels, patriotic song, monologue, popular song of to-day, military band, children's music, dance music, vaudeville, orchestra selections, etc.

Several record cabinets, sold exclusively by the Sonora Phonograph Corp., are also shown and described as well as the three new permanent needles which are meeting with such success. This house is distributing three of the latter, one being the multi-playing needle for lateral cut records, the second being a sapphire for vertical cut records, and the third is a diamond point needle.

A number of testimonials as to the efficacy of the Sonora as well as a small list covering a few of the owners of Sonora machines are included at the back of the book.

BE AN AMERICAN DEALER

WE ARE PREPARED FOR THE RUSH

WE ARE NOT THE LARGEST DISTRIBUTORS IN THE UNITED STATES—NEITHER ARE WE THE SMALLEST.

WE ARE GROWING

WHAT DIFFERENCE DOES IT MAKE WHO IS THE LARGEST? THERE IS GOOD BUSINESS FOR ALL. WE ARE NOT JEALOUS.

YOU—MR. DEALER—WANT THE GOODS

WE CAN GIVE YOU STOCK AND SERVICE. THAT'S WHAT COUNTS.

WE ARE RIGHT IN THE HEART OF BROOKLYN. ALL AROUND US ARE EXPRESS OFFICES, FREIGHT STATIONS, SUBWAYS AND OTHER TRANSPORTATION LINES, READY TO TAKE VICTOR GOODS TO YOU.

IF YOU ARE NOT AN AMERICAN DEALER, GET IN LINE NOW. SEND US YOUR ORDER. WE PREFER LARGE ONES, NATURALLY, BUT BEAR IN MIND SMALL ORDERS WILL RECEIVE EQUALLY AS PROMPT ATTENTION AS THE LARGE ONES.

AMERICAN TALKING MACHINE CO.
 368 LIVINGSTON ST., BROOKLYN NEW YORK CITY

TRADE IN NEW YORK SHOWS MUCH IMPROVEMENT.

Enjoys What Appears to Be a Country-Wide Condition—Dealers Now Getting Stocks Into Shape for Holidays—Dancing Craze Still Helps Trade—J. N. Blackman Recovering—Many New Columbia Dealers in Metropolitan District—Heavy Demand for Victors.

Local trade in talking machine circles the past month has been more encouraging and satisfying than the most pronounced optimist had hoped for, as many of the jobbers and dealers had expressed the belief last month that the continuance of the war abroad would cause a feeling of unrest that would materially affect all lines of merchandise. This belief, however, has been proven a mistake, as conditions the past month have shown a decided improvement that seems to be country-wide and not local. Returning traveling men report the most emphatic optimism in all sections of the Middle West, and with the Eastern States fast realizing that the coming fall should be a banner one, industrial activity in this section of the country is in the midst of a pronounced boom.

Dealers Replenishing Stocks.

In line with the improved status of affairs it is but natural that the jobbers and dealers should be turning their thoughts and attention to the replenishing of their stocks for the heavy selling seasons. The dealers as a whole have sadly neglected the rounding out of their machine and record stocks during the spring and summer months, and as a result good-sized orders are now being placed by practically the entire trade. The approach of the Christmas buying season is, as usual, witnessing the revival of speculation regarding the ability of the factories to handle all their trade during the busy months. Several jobbers and dealers have predicted that the winter of 1914-1915 will be the same as that of the last four or five years in that there will be a marked shortage of all classes of machines and records, principally the latter. Other members of the trade, on the contrary, assert that the increased manufacturing facilities installed by the manufacturers since the first of the year will enable them to turn out far more goods than formerly and keep pace with the demands of their trade.

Situation Is Rapidly Clearing.

Local general trade has suffered more from the psychological effects of the European war than any other section of the country, but this was to be expected, as the importance of this city as an export and import center, coupled with the stagnation in financial circles, have contributed to make the war a paramount consideration with thousands of New York merchants, both wholesale and import. The situation is clearing rapidly, however, and the reports submitted by dealers in Greater New York and the adjoining suburbs would indicate that machines and records are being sold the same as heretofore, and that the New York business world is adjusting itself to the new requirements of business life. That the war may prove an actual benefit rather than a handicap may be gathered from the steady increase in the exports of this port as compared with the figures of last year.

Indoor Dancing to Help Trade.

The indoor dancing season is now in full swing, and the advertising being used by many of the local talking machine establishments is particularly directed toward this class of trade. Contrary to general expectations, the so-called dance craze has outlived its experimental stages, and, although some of the older of the modern dances have fallen by the wayside, new ones are being popularized daily. These new dances are receiving the careful attention of the talking machine manufacturers, and as a result some of the new fox trot records, for example, are reported as being the best sellers of any records in the catalog for the month of September.

J. Newcomb Blackman Convalescent.

J. Newcomb Blackman, president of the Blackman Talking Machine Co., 97 Chambers street, Victor and Edison distributor, whose serious illness from typhoid fever was noted in this column last month, is now well on the road to speedy recovery and will in all probability be back at his desk by the 1st of November. R. B. Caldwell,

vice-president of the company, has been directing the destinies of the company the past two months with result-productive efforts, and the business for September was very pleasing. In a chat with The World Mr. Caldwell stated that the trade for the first part of the fall season was leaning decidedly toward the higher priced Victrolas and Red Seal records, the cheaper machines being left far behind in the advance orders of the company's dealers.

Recent Columbia Dealers.

The past month has been a very busy one at the wholesale headquarters of the Columbia Graphophone Co., 89 Chambers street, New York. A feature of the business the past few weeks has been the signing of many new accounts in the metropolitan district. A few of the recent ones closed last week are: C. R. Wheeler, Greene, N. Y.; Samuel R. Fruhtman, Milburn, N. J.; Stark

Bros., 3122 Fulton street, Brooklyn, N. Y.; C. K. Brown, Deposit, N. Y. "Our sales totals for September exceeded September of last year by a nice margin," said R. F. Bolton, manager of the company. "Our new 'Meteor' is meeting with a ready sale, but the 'Leader,' 'Mignonette' and 'De Luxe' are gaining in popularity rapidly. Collections have been very satisfactory, considering the general unrest throughout the country.

Reports of Progress.

G. T. Williams, manager of the New York Talking Machine Co., 81 Chambers street, Victor distributor, anent conditions remarked as follows: "September kept step with the business we closed the first eight months of the year in that we showed a substantial increase over September of last year. This month-by-month gain is more convincing when it is understood that 1913 was the banner year of our history. Personally, I am looking for a shortage in both machines and records this fall, as conditions are parallel to those of the past four or five years. The demand for Victor records of all classes is so tremendous that, notwithstanding the enormous output of the factory,

(Continued on page 26.)

At Your Service Only

We Do Not Retail

Our record stock is therefore always clean and perfect.

We have no retail department to provide for in the distribution of machines.

Musical Instruments
and
Musical Instrument Strings

An excellent line for the Talking Machine Dealer.

Your opportunity to increase profits at no additional expense.

Ask for our catalog.

C. Bruno & Son, Inc.

Established 1834.

351-353 Fourth Ave.

New York

There was once a Mississippi River Steamboat with a whistle so large that every time it blew, the boat was compelled to stop for lack of steam—

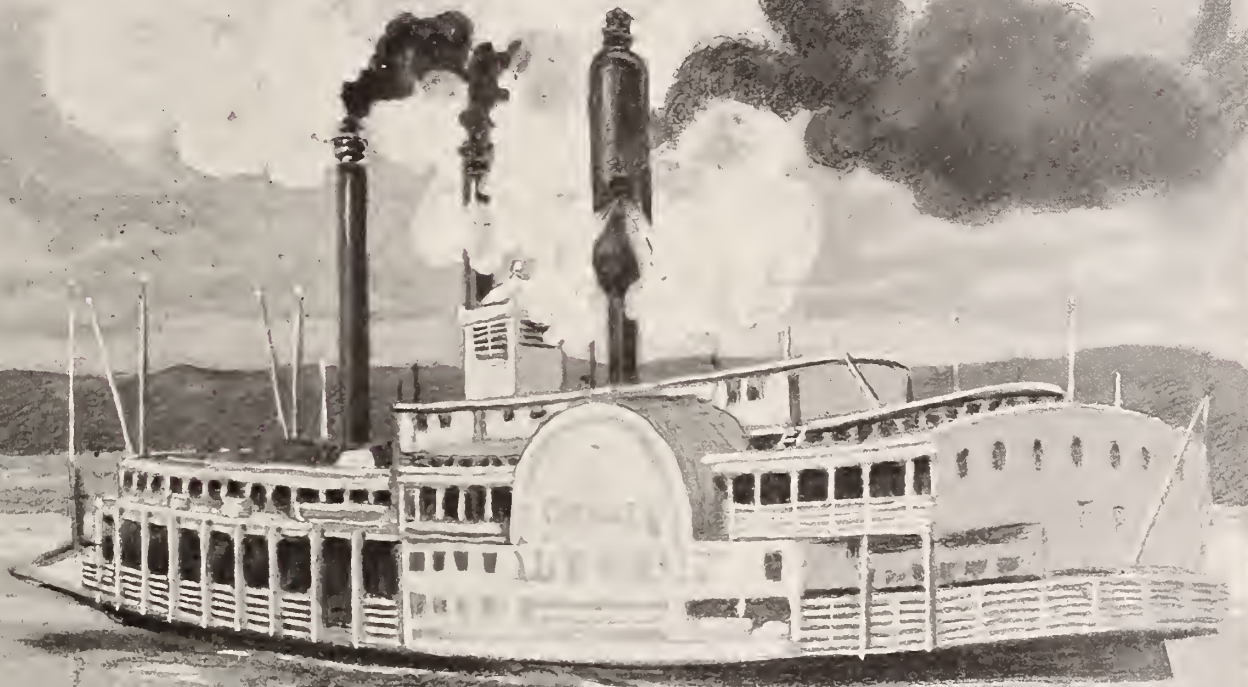

OUR SERVICE

No matter how great the tax upon it our organization meets the demands of our dealers their orders having *uninterrupted attention* and being shipped same day as received.



Write for our Stock Suggestions

NEW YORK TALKING MACHINE COMPANY
81 CHAMBERS STREET : : : : : NEW YORK

NEW YORK TRADE NEWS.

(Continued from page 24.)

the demand will be in excess of the supply. This will particularly apply to all of the new dance records which the Victor Co. has been issuing regularly the past few months.

C. F. Bruno Expects a Busy Fall.

Charles F. Bruno, secretary and treasurer of C. Bruno & Son, 353 Fourth avenue, and manager of the company's Victor business, is characteristically optimistic regarding fall and winter business. Mr. Bruno is in a position, however, to base this optimism on concrete facts, as the figures for September showed a fine increase over last year. As this company sells exclusively at wholesale, its concentration on dealer business makes for splendid service from all standpoints.

A. W. Toennies Is Optimistic.

A. W. Toennies, of the Eclipse Phonograph Co., 293 Washington street, Hoboken, N. J., exclusive Edison disc and cylinder distributor, is enthusiastic regarding the fall and winter outlook. "The Edison disc line is gaining far beyond my expectations," said Mr. Toennies. "We are signing up new dealers day by day, and those dealers who arranged to handle the complete disc line a year ago are now reaping the benefits of their early efforts. The new records are giving entire satisfaction, and the high quality of both the Edison disc phonographs and records is being recognized by many prominent musicians in this State who are patrons of our dealers. We are looking forward to a banner fall business, especially in the \$200 and \$250 models."

Acolian Co.'s Columbia Announcement.

The Acolian Co., 29 West Forty-second street, the prominent piano house, announced in last week's newspapers its acquisition of the complete Columbia line. The company called attention in its advertisement to the rapid strides achieved by the Columbia Graphophone Co. in developing its products, especially its records.

New Edison Shop Will Open Next Week.

The beautiful new Edison shop on Fifth avenue and Fortieth street is fast nearing completion, and

from all indications will be ready for formal opening the early part of the week. This new home of the Edison phonograph is one of the show places of the local retail trade, as the decorations and furnishings are both attractive and dignified. Every detail of the building, both exterior and interior, is in complete accord with the standing of the name of Edison and the high quality of the new Edison disc products.

Landay Leases New Quarters on 42d St.

Landay Bros., the well-known Victor distributors, with four stores in the high-grade shopping districts of the city, last week signed a ten-year lease to occupy the ground floor, basement and front section of the second floor of the building now occupied by the Estey Piano Co., 23 West Forty-second street. These premises are being completely remodeled and renovated for Landay Bros., and will be ready for occupancy the first of the month. This new store, marking another step in the remarkable progress and achievements of Landay Bros., will be furnished and decorated to harmonize with the company's other stores, which signifies that it will be another tribute to the merits of Victor products.

Closing of O'Neill-Adams Department.

The O'Neill-Adams store, at Twenty-second street and Sixth avenue, was formally closed the first of the month in accordance with an order of the United States District Court. This closing marks the passing of one of the largest and best equipped Victor departments in the city, the manager of which, William F. Lynch, has been appointed manager of the Simpson-Crawford Victor department.

RETURNS FROM SUCCESSFUL TRIP.

Lewis A. Lipman, road ambassador for the Uffner Album Co., 75 Grand street, New York, and well-known in the talking machine trade, returned last week from a very successful Southern trip on which he presented the many merits of the Uffner Patented Album in result productive fashion. Mr. Lipman, who left this week

for a New England trip, states that the new Uffner album is meeting with success wherever it is introduced, and giving perfect satisfaction.

EFFECTIVE COLLECTING METHOD.

"What methods do you find most effective in persuading careless customers to reply to correspondence regarding past due accounts?" This is a question recently found in the question box of the Sioux City Association, and when it was put to a meeting one member replied that he had on various occasions, with good results, used a letter containing only these words: "Shall we hear from you (date)?" or the words: "Shall we hear from you (date)? It is very necessary that we do." Another member stated that he had used the same words in a telegram.

NO HARM DONE.

Her friends had asked their young hostess to play for them, and she was performing a difficult selection from Wagner. In the midst of it she suddenly stopped in confusion.

"What's the matter?" asked one of the visitors. "I—I struck a false note," faltered the performer.

"Well, what of it?" cried another guest. "Go ahead. Nobody but Wagner would ever know it, and he's dead."

A WORD THAT SHOULD BE CANNED.

"Can't!" "Can't!" "Can't!" The world is weary of the word
Sounds exactly like the croak of some ill-omened bird—
Better far to say "I can!" "I can!" But, better still,
Let a fellow face the worst and say: "I will!" "I will!"

"Can't!" "Can't!" "Can't!" I wish we'd never hear again
That distressing syllable that spoils the plans of men,
Steals the courage from their hearts before the fight's
begun,
Makes them shirk the struggle that, once in, they might have
won.

"Can't!" "Can't!" "Can't!" Oh, let us drop it from our
speech!
'Tis a word that puts the goal, success, beyond our reach;
Let no thought of failure enter in, our faith to kill,
Let us can this "can't" and use the words "I will!" "I
will!"
—Dennis A. McCarthy, in "The New York Sun."



A200



A250

EDISON DISC and CYLINDER PHONOGRAPHS EXCLUSIVELY

Dealers of New York and New Jersey

We can assure you prompt and efficient service and deliveries by reason of our being the nearest distributors to the Edison factory, and therefore in a position to keep our stocks complete and up-to-date at all times.

Eclipse Phonograph Company

A. W. TOENNIES & SON

Edison Distributors

203 Washington St.

Hoboken, N. J.



A150



A80

For
EDISON DEALERS

Salter's Trade Maker, No. 180

Here's a Cabinet that any woman who appreciates the good things of life will simply "rave" about. It provides the living room or parlor with a handsome, harmonious piece of furniture, has the *appearance* of being *expensive*, and is *worth* a great deal more than the low price we ask for it.

You'll Be PROUD To Sell It

Your customers will be proud to *own it*—and it will give service and satisfaction that will be most gratifying to the person *who buys it*.

The felt lined compartments and ease of record selections are other winning points that make *sales easy*.

Our special booklet showing Salter Cabinets in use with Edison Disc Machines is yours for the asking.

EARLY BUYING IS ADVISABLE

We are already loaded with holiday orders—Write to-day.

SALTER MFG. CO.

339 N. OAKLEY BLVD.
CHICAGO

It Sells Itself!



**SALTER CABINET
No. 180**

With Edison Disc No. 80

PHONOGRAPH CO. OF KANSAS CITY

Has Most Attractive Quarters Under Management of W. P. Hope—Handsome Concert Hall Much Admired—Rooms Admirably Furnished for Display of Edison Phonographs.

(Special to The Talking Machine World.)

KANSAS CITY, Mo., October 6.—The home of the Phonograph Co. of Kansas City, exclusive Edison disc and cylinder distributor, at 1012 Grand avenue, is proving one of the centers of attraction for this city's music lovers. The comfort and home-

like atmosphere which pervades the warerooms is well calculated to place visitors completely at ease, and the detailed perfection of the warerooms' furnishings and decorations has been praised by all callers at the store. A feature of the establishment is the handsome concert hall which is shown in the accompanying illustration. W. P. Hope, manager of the company, is a firm believer in the sales and publicity value of holding informal concerts daily, and his efforts in this direction have been an important item in the rapid success the company is achieving. The store has only been

open a few months, but in this short while has gained for itself an enviable position locally.

E. R. CORNELL WITH NEW COMPANY.

(Special to The Talking Machine World.)

BOSTON, MASS., October 10.—E. P. Cornell, formerly manager of the wholesale Victor department of the Musical Instrument Sales Co., New York, and well known in the talking machine trade in the East, is one of the incorporators of the Patheoscope Co., of New England, chartered here with \$50,000 capital, for the purpose of dealing in motion picture devices. The other incorporator named is G. R. Armstrong, of Brookline.

VICTOR CO. BIG COTTON BUYER.

(Special to The Talking Machine World.)

NEW ORLEANS, LA., October 10.—Philip Werlein, Ltd., local distributor for the Victor Talking Machine Co., has been advised by the Victor Co. that it would purchase a bale of cotton for every agency it has in the South. This will be the largest purchase of cotton yet recorded and will amount to several thousand bales. The only stipulation is that the price must be ten cents per pound and the seller must be the producer.

NEW COLUMBIA AGENTS.

The past fortnight has been an unusually busy one for the Columbia Graphophone Co., a large number of new accounts having been signed up in the last few weeks. In Brooklyn, N. Y., particularly the Columbia products are gaining in popularity week after week, and at the present time Brooklyn territory from one end of the borough to the other is well dotted with the establishments of aggressive Columbia representatives. Among the newly created Columbia accounts are the following: George W. Millard, 1803 Myrtle avenue, Brooklyn, N. Y.; Hart Pharmacy, Westport, Conn.; Morris Finkelstein, Bridgeport, Conn.; Stark Bros., 3122 Fulton street, Brooklyn, N. Y.; J. Josephburg, 1671 Bath avenue, Brooklyn, N. Y.



The Concert Hall of the Attractive Quarters of the Phonograph Co. of Kansas City.

SIMPSON-CRAWFORD CO.'S ARTISTIC VICTOR DEPARTMENT.

One of the most attractive Victor departments in the local trade is that of the Simpson-Crawford

Although the Victor line is not literally a new addition to the Simpson-Crawford store, the pres-

prominently located on the fourth floor of the building, immediately adjoining the piano department, and are well calculated to win admiration by reason of their attractive appearance. This radical change was brought about by the policy of the new executive staff of the Simpson-Crawford store, which realized the unlimited possibilities of the up-to-date Victor department.

William F. Lynch, formerly manager of the O'Neill-Adams Victor warerooms department, and well known in the local trade, is manager of this new department, assisted by a group of efficient sales people. There are six record booths and two machine demonstration rooms in this department, and plenty of space is available for the construction of additional booths when needed.

The success of the moving picture slides issued at frequent intervals by the Columbia Co.'s advertising department has resulted in the recent production of a new set of

five slides, featuring primarily the dance product of the company. One of the slides has a clock device, making it of unusual adaptability for motion picture theater display.

"A piano always sounds loud in a flat."
"That is one of its advantages. It drowns the discordant criticisms of the neighbors."



Enlarged Department in Well-Known New York Store Devoted to Victor Talking Machine.

store, Nineteenth street and Sixth avenue, a portion of which is shown in the accompanying illustration. This department was formally opened a few weeks since, and the signal ability of the sales staff and the detailed conveniences offered visitors and prospective purchasers have been important factors in the success the department is already achieving.

ent showrooms may be actually termed a "new" department, as they represent an entire renovation and remodeling of the Victor warerooms the store formerly used. Whereas the Victor department last year occupied a very insignificant portion of the third floor, without any of the up-to-date equipment that characterizes the average modern Victor department, the new warerooms are

AN AGENCY FOR THE PRICE OF ONE PHONOGRAPH

C "CRESCENT" = THE BEST

R Do not take our word for it.
Make the test yourself, but do
E not delay so long as to lose
THIS YEAR'S BUSINESS.

S



C Write for description of
Lower-Priced Instruments,
Record Files for any Machine

E and
CRESCENT Jewel
Point RECORDS.

N (For use with
Crescent
Phonographs
only).

T

"YOUR (or some one else's)

BEST SELLER"

CRESCENT TALKING MACHINE CO., Inc.
99 CHAMBERS STREET, NEW YORK CITY

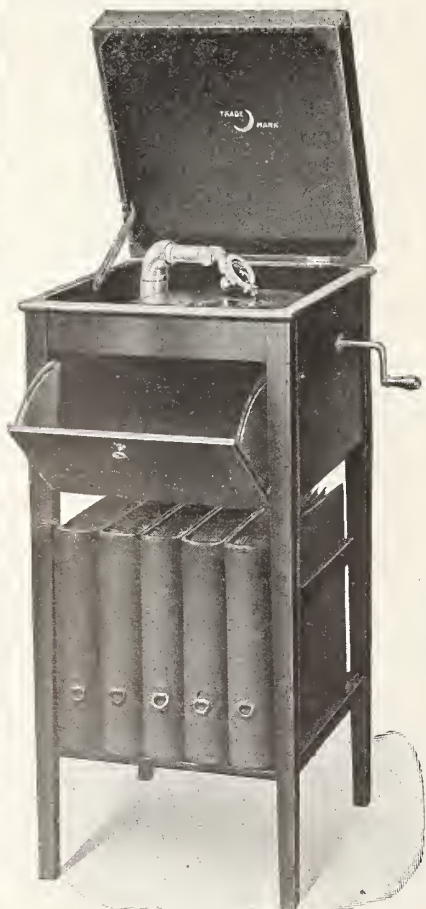

\$40

(Not Including Albums)

PLAYS PERFECTLY

PATHÉ RECORDS

ASK FOR OUR PRICES ON THESE RECORDS

BUY-A-BALE-OF-COTTON MOVEMENT.

Supported in Virginia—Ogden First to Purchase a Bale in Lynchburg.

(Special to The Talking Machine World.)

LYNCHBURG, VA., October 7.—The first bale of cotton which arrived in Lynchburg on the "Buy-a-Bale-of-Cotton" movement is in front of the store of J. B. Ogden, the enterprising talking machine dealer and cabinet manufacturer of 206-208 Eighth street.

Upward of thirty business men representing every industry of importance in this city held a



Cotton Bale in Front of J. B. Ogden's Store. general meeting in the Chamber of Commerce, and it was decided that the business interests support the "Buy-a-Bale-of-Cotton" movement to the utmost. Nearly 200 bales were subscribed for at the meeting, and upwards of 800 bales have been purchased in this section. Mr. Ogden's bale was purchased from J. N. Swanson, of Houston, Tex., to whom he sent a patriotic communication.

WHY THE CHEERY MAN WINS.

There is no place in the talking machine trade for the long-faced person—the man who lacks geniality and who fails to warm up to a prospect. It will pay to shelve the blues at all times, for optimism is a mighty good business lubricant, and the merchant who is always cheerful is likely to be more successful in attracting trade than the pessimist who is continually croaking about business being bad, almost invariably presenting a woebegone countenance. The optimist will turn even his mistakes to good account and cheerfully hunt up evidence of errors so that the antidote may be administered. That is just as effective a method of business-building as increased sales, and it means building on a good foundation.

Examples are not lacking of retail concerns that have doubled their sales only to find their actual financial standing inferior to what it was when only half the volume of business was being done. It behooves the merchant to be ever on the watch for shoals and pitfalls, and the correction of little mistakes will tend to fortify his position against the possibility of the bigger and more disastrous one. Thus the lessons learned by reason of little errors of judgment will be turned to advantage in building up a stronger business, equipping the merchant for expanding it on sound lines.

About the only thing in this life that a man can win in a walk is a game of golf.

No man is thoroughly accomplished unless he has an ability to mind his own business.

COLUMBIA LINE IN PROVIDENCE.

The Tilden-Thurber Co. and the J. A. Foster Co., Two Prominent Establishments in That City, to Feature Columbia Line.

"Business conditions in New England are vastly improved as compared with those existing a few months ago," said H. A. Yerkes, manager of the wholesale department of the Columbia Graphophone Co., who returned this week from a trip through this territory. "There is renewed industrial activity throughout the New England States, and there is every indication of the coming fall being equal to last year's business and even exceed it in many lines. Our own business in this territory is increasing rapidly."

While in New England Mr. Yerkes closed a number of important deals for the representation of Columbia products, including the Tilden-Thurber Co. and J. A. Foster & Co., of Providence, R. I. The first named house is one of the best known high-grade jewelry houses in New England and caters to a clientele that includes the most prominent people in its territory. The company has maintained a piano department for over a year with pleasing success, and is in an excellent position to forcefully present the Columbia line. J. A. Foster & Co. are one of the oldest talking machine establishments in New England, and Mr. Yerkes is enthusiastic regarding the company's recognition of the sales possibilities of the Columbia line.

NEW CONCERN HANDLES TALKERS.

The Geo. B. Peck Dry Goods Co. Has Opened a Very Attractive Department and Buys Large Stock from the Schmeizer Arms Co.

(Special to The Talking Machine World.)

KANSAS CITY, Mo., October 7.—The Schmelzer Arms Co., Victor distributor, has just closed a deal with the George B. Peck Dry Goods Co., of this city, whereby they will put in a Victor department. They will devote an entire half floor of their new building to this line. The company just delivered to them the largest individual order delivered to any dealer in this part of the country.

John Ditzell, formerly with the Columbia Graphophone Co., will be manager of the new department. They have installed six demonstration rooms and a concert hall and will go after the business vigorously.

IMPROVES THE CABINET INTERIOR.

"Felteen" is the latest production of the Herzog Art Furniture Co. in connection with the well-known Herzog record cabinets. The trade has been demanding just such an interior felt lining as "Felteen" for some time, and this latest product of the well-known Saginaw establishment nicely supplies the demand. It is found that "Felteen" acts as a protection on the records and greatly improves the interior of the cabinets. It would be well in ordering record cabinets to specify "Herzog Felteen Lining."

**WAR
IS
HELPING US ALL
IF WE ARE LIVE DEALERS**

Every LIVE DEALER is preparing for the HOLIDAY BUSINESS, which will soon be on us.

**"TO BECOME A
BLACKMAN DEALER
IS TO
BE PREPARED"**

(BLACKMAN)

The first step to become a "BLACKMAN DEALER" is to send a few trial orders. "BLACKMAN SERVICE" will hold you.

BLACKMAN TALKING MACHINE CO.

J. NEWCOMB BLACKMAN, Pres.

97 CHAMBERS ST., NEW YORK



Another Exclusive Another Visible The Columbia Individ

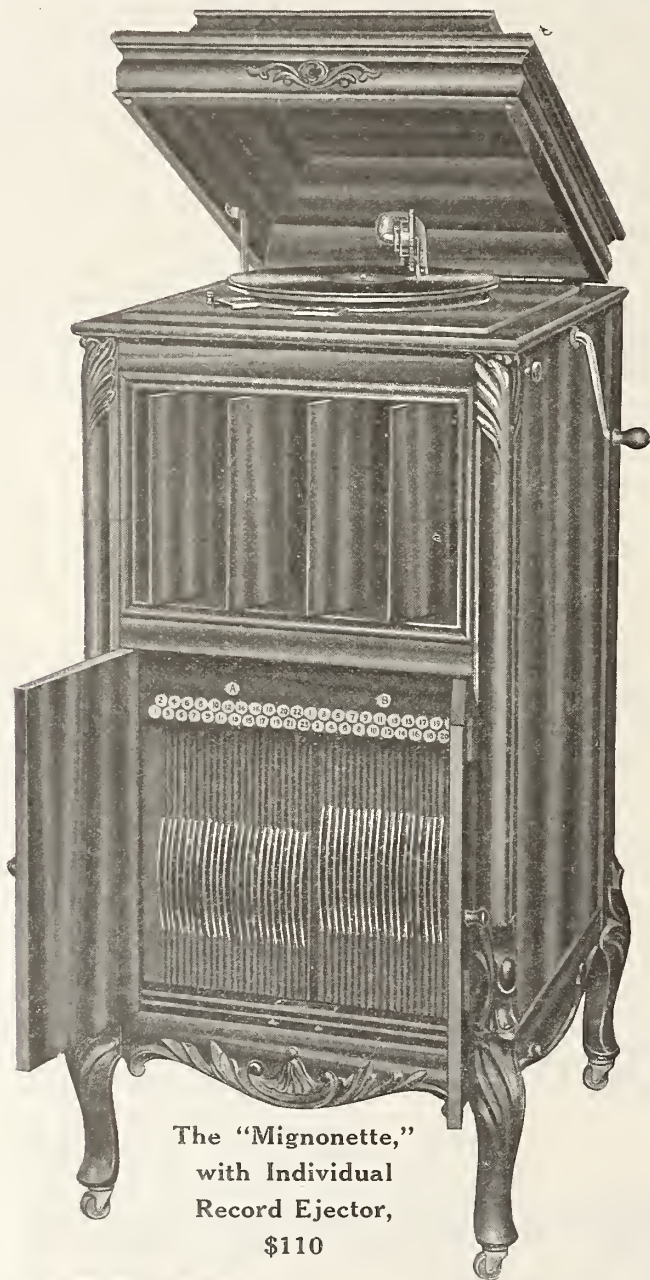

The "Mignonette,"
with Individual
Record Ejector,
\$110

Press the button and out
way it works!

Each record is accommodat
edged with plush, which acts
vice for the record both when
put back. This convenient fi
of every prospective owner of
and this is an innovation whic
has ever strained finger and
record in a crowded cabinet.

The first Columbia instr
"Leader" and "Mignonette."
and attractive appearance o
with this new device.

The price of the "Leade
"Mignonette" \$110.

The addition of the Colum
in the "Leader" and the "Mi
the present styles will be dis
judging by the increased call f
record racks (the "Leader" at
\$100) they appear to be just



Graphophone Company, Wol

Creators of the talking machine industry. Pioneers and leaders in the talking machine art. Owners



Columbia Feature "Selling Point" Individual Record Ejector

...es the record—that's the

...n a separate compartment,
...an automatic cleaning de-
...taken out and when it is
...of records is in the mind
...alking machine, nowadays,
...ill appeal to everyone who
...umb trying to get hold of a

...ents so equipped are the
...e pictures show the neat
...oth instruments provided

...so equipped is \$85; the

Individual Record Ejector
"Mignette" does not mean that
...tinued. On the contrary,
...hese two instruments with
...5 and the "Mignette" at
...popular as ever.

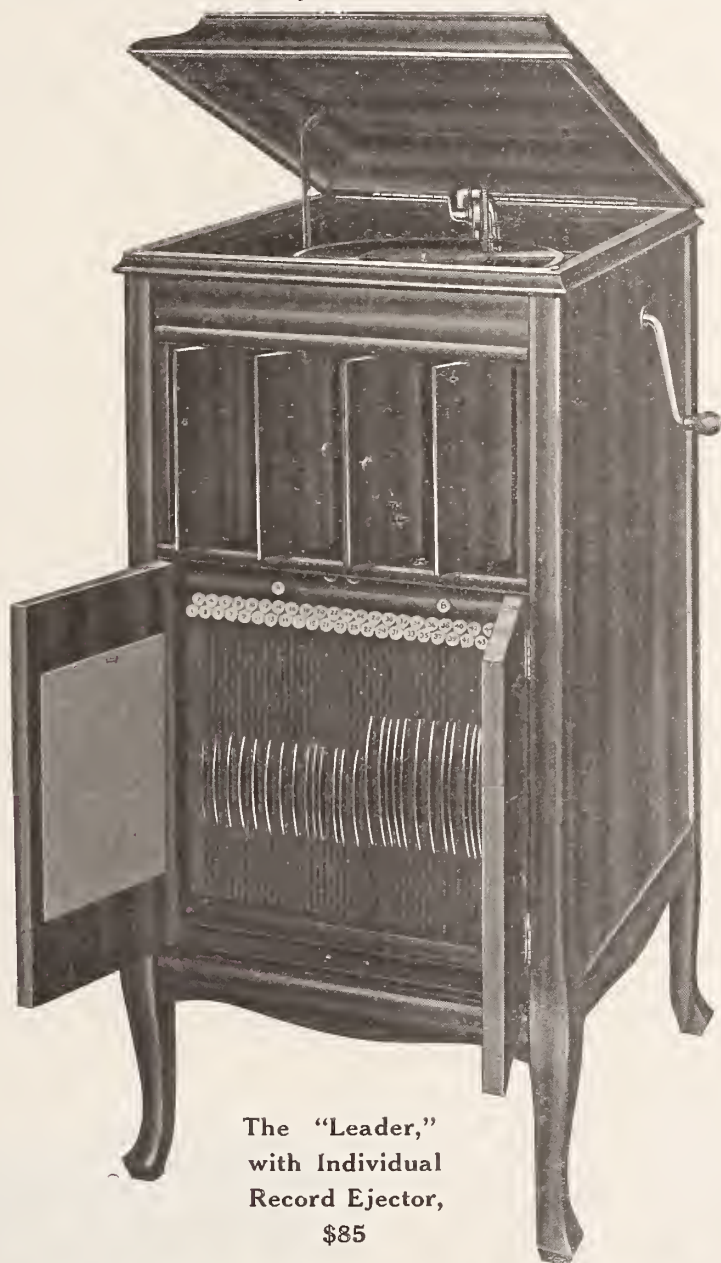

The "Leader,"
with Individual
Record Ejector,
\$85

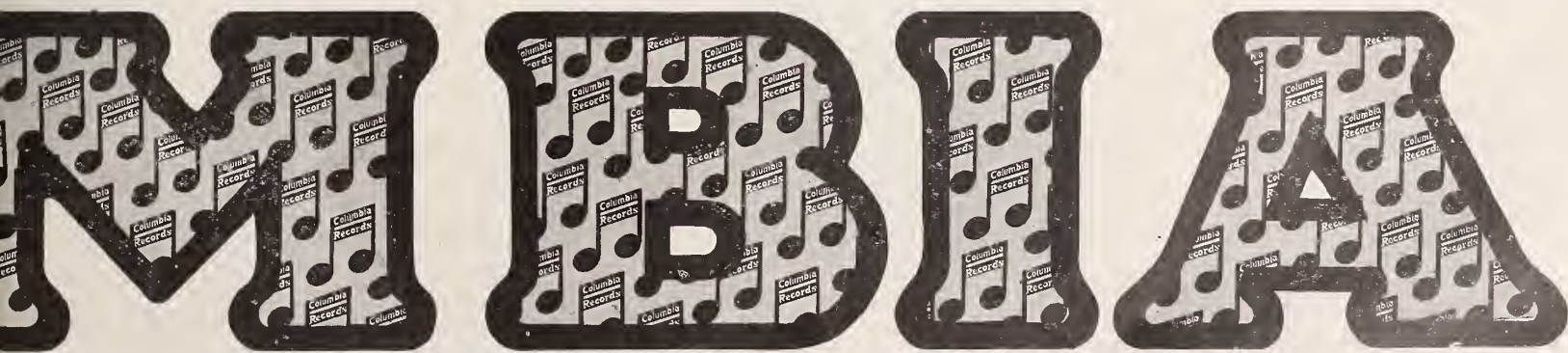

...lworth Building, New York

...he fundamental patents. DEALERS WANTED WHERE WE ARE NOT NOW ACTIVELY REPRESENTED.

UNICO DEMONSTRATING BOOTH.

Built on the Unit System Sound-Proof and Dust-Proof Are Utilized by Local Talking Machine Dealers Throughout the Country for Successfully Displaying and Demonstrating Their Stock of Talking Machines.

Too much emphasis cannot be made upon the value of quietude in the sale of talking machines, for no prospect will listen to talking machine demonstrations in the same room that other instruments are being played. But until recently it was impossible to secure a talking machine booth, except at an almost prohibitive cost, that would help to increase these sales. Knowing this situation, George W. Smith & Co., Inc., Sloane street and Powelton avenue, Philadelphia, who make nearly \$1,000,000 worth annually of store fixtures, believed that by making a booth in units of three feet which could be installed easily in the talking machine wareroom there would be enough dealers who would want to have their warerooms modernized.

In putting up the proposition of Unico booths to some of the houses in the trade it did not require a great deal of time to convince them of the value of such booths, among them being such houses as these: Lyon & Healy, Chicago; Rudolph Wurlitzer Co., Cincinnati; Frederick Piano Co., Pittsburgh; Gimbel Bros., New York City; John Wanamaker, Philadelphia; Krell Piano Co., Cincinnati; E. F. Droop & Sons Co., Baltimore; Aeolian Co., New York City; Fulton Music Co., Waterbury, Conn.; Humes Music Co., Columbus, Ga.; Clayton Piano Co., Salt Lake City; R. H. Macy & Co., New York City, and a great many others.

Briefly speaking, Unico booths are built on the unit system, in multiples of 3 feet long by 8 feet high, making it possible to enlarge or reduce the booth sizes as desired. Absolutely soundproof and dustproof, which are features of Unico booths that are alone worthy of consideration. Made in eight regular designs, in oak, birch, quartered oak and mahogany, with special finishes to order. The booth design No. 3, which is one of the leading sellers has won a large degree of favor, as the design is handsome and beautifies any store. Furnished complete with double construction, hollow corner posts for electric wiring, crystal sheet glass, double glazed for walls, with either Florentine or double-strength American ceiling, and sand-blast statuary bronze-finish hardware.

The cost of Unico booths is less than what would be paid for the ordinary nailed together "hen-coop" style of booths, which are altogether too costly for the character of work, and if a wareroom is to be changed in layout it requires a large outlay for workmen, whereas with the Unico booth they can be taken down and erected, even changing the size, as remarked before, in a few hours.

An illustrated catalog in two colors, showing the various styles of Unico booths, has been issued by George W. Smith & Co., Inc. It is most interestingly written, and its perusal will give some original ideas as to booth making and wareroom improvements. It is mailed gratis upon request.

CENTURY OPERA PUBLICITY.

The opening of the Century Opera House in New York has again placed Columbia records prominently before the attention of local music lovers, as several of the most popular members of the Century Opera Co.'s galaxy of stars are Columbia artists. These include the prominent tenors Walter Wheatley, Orville Harrold and Morgan Kingston, in addition to Louis Kreidler, who scored a signal success last week in the presentation of "William Tell." In accordance with its plan last year, the Columbia Co. has reserved the back cover of the Century Opera Co.'s official program, where it will display timely and appropriate copy during the operatic season.

The Eclipse Talking Machine Co. has leased the store and basement at 214 Main street, Paterson, N. J.

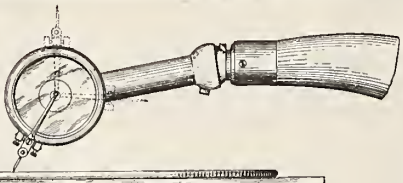

NO. 1





NO. 2

Huff's Sound Box Attachment

PATENT PENDING

You can use VICTOR, COLUMBIA, Union or Exposition Sound Box on Edison Machines with Huff's Attachment.

PRICE, Gold Plate \$3.50 Nickel \$3.00
Sample in Nickel \$2.00 Gold Plate \$2.25

Money back if not O. K.

Inventor and Manufacturer **S. E. HUFF**
919 So. Flower St., Los Angeles, Calif.

EDISON DISC MUSIC AT FUNERAL.

Machine and Suitable Records Takes Place of Quartet in Church Services and Brings Forth High and Earnest Praise.

The following incident, which occurred in Fall River, Mass., shows how acceptable Edison disc music is at funerals.

W. D. Wilmot, the Edison dealer there, writes as follows to the Edison Phonograph Monthly regarding the incident: "On Wednesday, September 16, a gentleman telephoned to ask if I rented phonographs for funerals. I asked for particulars. He told me that he had been unable to secure a quartet for his wife's funeral to be held at the Brownell Street Baptist Church on that afternoon, and would like to hire an Edison disc phonograph.

"I told him that I would be glad to do him this kindness without charge, and that I myself would come to the church and operate the instrument during the service.

"We placed the Edison disc phonograph in the gallery at the rear of the church, where no one could see either it or myself. I played No. 80,064, 'Beautiful Isle of Somewhere,' and both sides of No. 80,127, 'Lead, Kindly Light,' and 'One Sweetly Solemn Thought.'

"The officiating clergyman has since called twice at my store to emphasize his approval of the innovation, while the husband, Mr. Brown, has also called twice to thank me, and to say how many expressions of appreciation of the music he has heard.

"To-day he published 'Card of Thanks' in the Fall River Daily News. Two leading local clergymen spoke to me most approvingly concerning the use of the Edison."

Only a little practice has knocked many an attractive theory into a cocked hat.

THEY GAVE A PICNIC.

The West Music Co., Joliet, Ill., of which A. D. Hopkins and G. A. Wiswell are the proprietors, recently gave a picnic on the Du Page River.

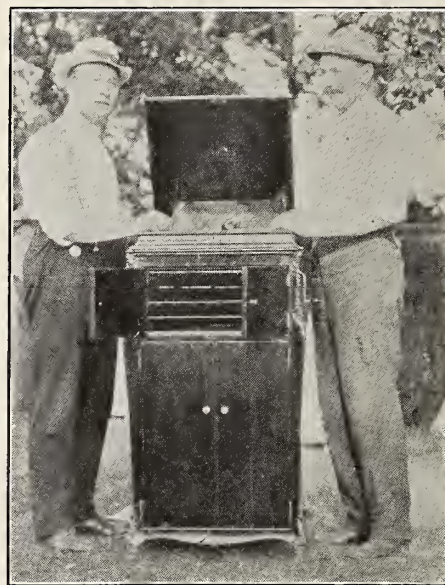

Several hundreds of Joliet citizens attended. There was plenty of air and plenty to eat, and plenty of music. The cut shown in this connection shows Charles Stall and A. G. Gurney, who helped the company in the arrangements of the picnic, at the Victrola. The piano for which the company is the agents was also used to good effect.

Anton Heindl, manager of the foreign record department of the Columbia Co., returned to America last week after being marooned abroad since the start of the war and narrowly escaping being impressed into service in the Austrian army.

LONG CABINETS

A NEW PATTERN FOR 1914-15



D70

FOR VICTROLAS VIII. and IX.
Mahogany, Fumed Oak, G. O. and W. O.

New illustrated matter of the whole line will be cheerfully sent on request.

Kindly anticipate your requirements, naming dates for shipments.

The Geo. A. Long Cabinet Co.
Hanover, Pa.

Address **Clement Beecroft, Sales Manager**
309 W. Susquehanna Avenue, Philadelphia

KOERBER-BRENNER CO. BROUGHT INTO PROMINENCE

As Exclusive Victor Jobber in St. Louis, Mo., Through Retirement of Aeolian Co. from Jobbing Field—Well Equipped to Supply Demands—Review of Business Situation—Silverstone's New Concert Hall—Activity with the Columbia Co.—Other News.

(Special to The Talking Machine World.)

St. Louis, Mo., October 10.—Talking machine dealers are very well pleased with the condition of trade here, considering the general state of business. From jobbers it is learned that the business for September for the city was nearer than within 20 per cent. of anticipations of what it should reach before the war interfered, and that the record business has held up very well indeed. The fact that people still are buying machines has been more or less of a surprise to dealers when they hear the complaints from other lines of business. The bulk of the machine business is on high-priced instruments.

The country business has held up very well, indeed, and taking it as a whole, the trade has been surprisingly good.

As to collections, the trade is a unit in saying there has been little or no faltering among those pledged to weekly or monthly payments.

All of the talking machine men appear to be unanimous in believing that the war distress will be short-lived, and as soon as the industrial world can right itself under its forced new bearings, which will be very soon, there will be rapid recovering and that business will go on with a boom that will enable them to outstrip previous records for sales. It is rather curious that the talking machine men are extremely optimistic, while in so many lines there is pessimism. This may be due to the influence of the music that they hear constantly, who can tell? If it is, perhaps it would be well to distribute some talking machines among the bankers and financiers who continue to take the gloomy view of everything.

The feature of the talking machine situation here this month was the withdrawal of the Aeolian Co. from the jobbing trade and the addition of the Columbia line to the retail department at Aeolian Hall. The notices to the trade announcing the withdrawal of the company from the jobbing business was made on October 1.

Mark Silverstone, president of the Silverstone Music Co., recovered from his severe attack of hay fever sufficiently late in September to make a business trip to some of the larger cities in the South, and says that he was not at all impressed with the stories spread through the North of distress in that section. He found Memphis and other cities that he visited busy and alert and the merchants preparing for a good winter trade, and that his orders were better than he had reason to expect when he left home. At least he found confidence much greater than he anticipated.

The first of the month saw the finishing touches put onto the new concert hall and main floor demonstration booths in the Silverstone warehouses and the general appearance of the store is greatly improved thereby, having lost the one-sided appearance that was so prominent while booths were ranged on only one side of the room.

But the visitor must get into the concert hall to appreciate it. It seats more than 30 persons in roomy, comfortable wicker chairs, has concealed lighting system and perfect ventilation supplied by ceiling ventilators and an electric fan driving the air outside through a flue. The most artistic touch, however, is given by an art glass background to the stage, where a handsome Edison disc machine stands. This art glass background extends from the floor to the ceiling curve and is composed of two sections, the upper of which contains the name "Edison" in letters about twelve inches high and extending across the stage. The lower panel is composed of musical decorations.

**NEW JERSEY
PRICE TALKING MACHINE CO.
VICTOR DISTRIBUTOR
(Exclusively)
We can supply ALL your wants on time.
NEWARK**

all done in soft, restful colors that are sufficiently contrasted to be decorative, but not enough to distract the attention of the auditor.

It is the plan to use the concert hall at all hours of the day to demonstrate the weekly lists of records and such other numbers as are requested by those present. The concert will be continual during business hours if the attendance warrants. More than 30,000 invitations are being sent to the best homes in the city.

One of the notable sales at the Silverstone store last week was that of a \$150 machine to a customer who a few months ago bought a \$400 instrument. The higher priced machine occupies a place of honor in the music room of the customer's handsome home and the \$150 one will go in the ballroom on the third floor.

The withdrawal of the Aeolian Co. from the Victor jobbing trade here has brought the Koerber-Brenner Music Co. into prominence, as to them falls the jobbing business of this field, an unexpected development to them and to the retail trade generally. This happens also at an opportune time, as the Koerber-Brenner Co. only a few months ago decided to give up its small music goods trade and devote its entire attention to the Victor line, so it has available exceptional facilities in the way of office force and warerooms to meet with this demand. Also the Koerber-Brenner Co. recently undertook an aggressive selling campaign and stocked up accordingly, hence it has an exceptional stock to meet any additional demands. In speaking of the situation, E. C. Rauth said:

"Naturally we regard our present situation as something of an obligation upon us to meet all of the demands of the trade in this section and we will strain every resource to care for additional trade that may fall our way. We will have the stock and will add to our organization in any way that may be necessary to fulfil any implied organization that may see fit to come to us as selling representatives of the Victor Co., as we regard ourselves as a part of the organization and as the connecting link between the factory and the retailer. We would be unworthy of the Victor organization if we did not provide at once for the meeting of all unusual and perhaps unexpected demands.

"While, of course, we welcome the opportunity to extend our trade and gladly welcome new customers, our connections with the Victor Co. are such that we place the meeting of the demands the company's retailers may make upon us above the mere commercial extension, for the present at least. We want any part of the trade in this section to feel that we are obligated to meet their demands just as much as though they had been our customers, for we regard a Victor obligation as our obligation."

At the Columbia warerooms Manager Reid says that the wholesale end has held up surprisingly well and that collections are better than general business talk would indicate. He has concluded, after hearing the tales of men in other business, that talking machine men are to be congratulated.

Mr. Salmon, of the wholesale sales department, returned early in the month from North Missouri and reported a very good trip and the farmers in that grain section well pleased with their present condition and the financial prospects. Mr. Bennett, also of the sales force, remained in that section to close up a number of deals. For the present the Columbia is not seeking new business in the cotton and lumber country to the south.

"Of course business just now is hard to get, but my experience has been that there is a way to get it," said Mr. Reid. "Just now we are putting in our best licks where we believe that business exists and that it is possible to close it up. We are sending our jobbing salesmen into sections where they have money to buy talking machines and we are making gains there.

At Your Service

Landay BROS. INC.

**VICTOR DISTRIBUTORS
EXCLUSIVELY**

Connect Yourself

with the Progressive House who will be glad to advise you how to obtain more retail business.

OUR POLICY

"No account accepted unless perfect service can be assured."

Automobile service in New York City will insure our dealers prompt delivery.

Motor suburban service will insure out-of-town dealers earlier deliveries.

VICTOR Contracts are now ready for mailing to those dealers who wish to take advantage of our perfect service for the coming season.

Our representative will gladly call upon request.

**WHAT YOU WANT
WHEN YOU WANT IT
ALWAYS IN STOCK**

Landay BROS. INC.

563 FIFTH AVE.

NEW YORK

THE AEOLIAN COMPANY
Takes Great Pleasure in Announcing a Most Important
Addition to its Talking Machine Department. The
COLUMBIA GRAFONOLA
AND THE FAMOUS
COLUMBIA RECORDS
Will Hereafter Be Obtainable at **AEOLIAN HALL**

This Company is keenly gratified at being able to make the above announcement.
Those familiar with the talking machine field recognize the strides that have been made by The Columbia Graphophone Company in developing its instruments, and especially its records.
In adding these machines and records to its already wonderfully complete Talking Machine Department. The Aeolian Company further emphasizes the broad policy by which it has grown.
—To offer the best in every line it handles
—To sell at the lowest price at which standard goods can be obtained
—And to conduct every transaction in a spirit of courteous fair dealing.

THE AEOLIAN COMPANY
"Largest Manufacturers of Musical Instruments in the World"
AEOLIAN HALL, 29-33 W. 42nd St., Bet. 5th & 6th Aves.

This announcement of the Aeolian Company, which appeared in all the leading New York newspapers carries a significant message to every talking machine dealer.

Does it not suggest to *you* the benefits you may secure in handling Columbia Grafonolas and Columbia Double-Disc Records ?

COLUMBIA

Graphophone Company

Woolworth Building, New York



TRADE ACTIVE IN SOUTHERN CALIFORNIA.

Despite Disturbance Caused by European War, Demand for Talking Machines Is Greater Than Ever, with the Higher Priced Goods in Favor—Leading Houses Active in Way of Attractive Window and Wareroom Displays to Interest Public—News of Month.

(Special to The Talking Machine World.)

LOS ANGELES, CAL., October 6.—Notwithstanding the war and the general business depression, the talking machine trade in southern California is opening up this fall in a manner which bids fair to surprise all previous records. The demand for the larger models in all makes of talking machines is greater than ever before at this time of the year. The only drawback seems to be our inability to get machines and records. This may be due, in a measure, to our great distance from the source of supply. However, all the jobbing houses predict a full supply for the holiday trade.

Tuesday, September 8, marked the 123d anniversary of the founding of Los Angeles. A municipal carnival commemorating that event was given on the old Normal School site. A wide and varied program was given. The Southern California Music Co. supplied three Model A250 Edison disc machines, which elicited many favorable comments from thousands.

A very unique window display was given by the Wiley B. Allen Music Co. last week, consisting of three couples of dancing dolls, while four couples were seated around them as interested spectators. The dancers were made to revolve, reverse, dip,

etc., just like they were alive. The dance was performed around a talking machine. This window attracted hundreds of people and was a great advertisement for the new dance records.

R. E. Wolfinger, of the Wiley B. Allen Music Co., has a novel scheme whereby the English records of our greatest singers may be more thoroughly enjoyed by his prospective customers. Mr. Wolfinger makes typewritten copies of the songs, which are given to the customers to follow while the records are being played, thereby enabling them to get a much better impression of the clearness of the enunciation of the machine than would otherwise be obtained. Cornelius Muers, formerly with the J. B. Brown Music Co., is now connected with the Allen house.

H. E. Lindsey, who was with the Wiley B. Allen Music Co., of Portland, Ore., is now with their branch in this city.

The Andrews Talking Machine Co. has added greatly to the efficiency of its department by the addition of another large demonstrating room. M. B. Sharp, formerly with Sherman, Clay & Co., San Francisco, is now with this company.

The Birkel Music Co. reports greatly increased sales of all models of Victrolas.

Charles Ruggles, local manager for Sherman, Clay & Co., reports two new Victor agencies, the Becker Pharmacy, of Calexico, Cal., and W. H. Saladin, of Lompoc, Cal., both of whom have placed substantial orders.

Ralph H. Paulin, manager for fifteen years of the talking machine department for the Guernsey S. Brown Music Co., of Santa Barbara, has recently purchased that department and greatly increased the stock. Mr. Burson will be connected with him.

T. T. Gardner, of the Gardner Music Co., Gardena, has lately added the Edison disc agency to his line. He reports a flourishing business, having sold a Model A150 and a Model A250 the first week.

O. A. Lovejoy, of the Southern California Music Co., reports a brisk trade in both the Edison disc and cylinder lines.

The new Edison idea of putting six disc records on sale every week is meeting with great favor in this community.

George B. Austin, of Oxnard, was in the city recently. He placed a substantial order for both Edison disc and Edison cylinder machines and records.

The Columbia Graphophone Co., wholesale, reports a big demand for four new model machines.

E. Holland, of the Holland Music Co., located at Vernon and Central avenues, reports a fine business in Edison cylinder machines and records. Mr. Holland makes a specialty of this line and is increasing his business daily.

A NEW LOW-PRICED RECORD.

The "Little Wonder" Record, Backed by Henry Waterson, the Well-Known Music Publisher, Is Only Five and One-Half Inches in Diameter and Retail at Fifteen Cents.

If the latest venture of Henry Waterson, head of the Waterson, Berlin & Snyder Co., the prominent music publishers of New York, develop as the promoters expect, owners of talking machines will be able to buy records as they buy sheet music at the present time, and at about the same price.

Mr. Waterson, in short, is sponsor for the new Little Wonder record, which has just made its appearance on the market and sells for fifteen cents retail. The new records are of the lateral cut type, may be played on the various machines using that type of record, are five and one-half inches in diameter and play for about one minute and forty-five seconds. The records are large enough to hold one verse and two choruses of a song and the reproductive qualities are very good.

Mr. Waterson stated to The World that the present catalog of "Little Wonder" records contains about fifty selections and that it will be added to at the rate of fifteen selections monthly. The distribution will not be confined to any one class of store, but the records will be sold in music stores, stationery stores and through other similar agencies. A new machine to use the record has been designed.

Alice Nielsen, the popular operatic soprano and a Columbia artist, will appear next Tuesday at Hackensack, N. J. to sing at a concert given on behalf of the Children's Relief and General Welfare Society of that city. Miss Nielsen will appear in conjunction with Rudolph Ganz, the internationally prominent pianist. Mrs. George W. Lyle, wife of General Manager Lyle of the Columbia company, is an active patroness of the Children's Relief Society of Hackensack.

Statement of the ownership, management, etc., of The Talking Machine World, published Monthly at New York, required by the Act of August 24, 1912.

Name of Editor, EDWARD LYMAN BILL... 373 4th Ave., N. Y.
 Managing Editor, J. B. SPILLANE... 373 4th Ave., N. Y.
 Business Manager, AUGUST J. TIMPE... 373 4th Ave., N. Y.
 Publisher, EDWARD LYMAN BILL... 373 4th Ave., N. Y.
 Sole Owner, EDWARD LYMAN BILL... 373 4th Ave., N. Y.

The Talking Machine World, Per August J. Timpe, Business Mgr. Sworn to and subscribed before me this 22d day of [SEAL] September, 1914.

Eugene R. Falck, Notary Public 4 (My commission expires March 30, 1916.)

POPULAR FOR DANCING.

Columbia Records Make Ideal Substitute for Orchestra, Writes Dancer.

With the start of the indoor dancing season, the Columbia Graphophone Co. is steadily adding to its long list of testimonial letters from successful dancing instructors. One of the recent communications was that sent by Miss Edythe Parker, a prominent exponent of the modern dances, who writes:

"I did not believe it possible that the Grafonola could satisfactorily take the place of an orchestra for dance purposes, but I am very glad now that you insisted on my giving it a trial. It is simply a revelation to me. The Columbia double-disc records of the new dances are simply marvelous for the life, swing, snap and perfect tempo. They are faultlessly played and are of the greatest assistance to me in my work. I most sincerely recommend their use by every dance teacher in the country. They are wonderful."

"BETTER THAN AN EXTRA CLERK"

THE "OGDEN"

Sectional Filing Cabinet and Sales System

If You Knew a Young Man Who Could Increase Your Business, You'd Employ Him—Then Why Not Install a Filing System that Will Do the Same Thing for Less Money?

PAST THE EXPERIMENTAL STAGE

The "OGDEN" has stood the test and made good—is making good today in hundreds of stores—is ready to make good for you. Has a simple, adjustable signal system for quick filing and ready reference—gives you any record in stock in four seconds. Complete in the minutest detail and fully guaranteed to be just as represented. Do away with the old style, out-of-date cabinets—install the new "OGDEN" and watch your sales and profits grow, while your "dead stock" decreases. It's a matter of dollars and cents with you and worthy of immediate investigation.

Jobbers in all Sections. Write for Descriptive Literature and List of Jobbers.

Manufactured by

J. B. OGDEN LYNCHBURG, VA.

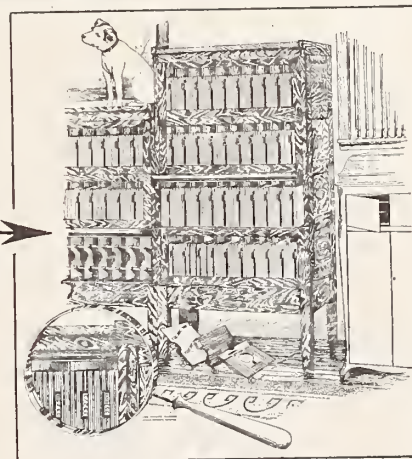

SAVES TIME, SPACE AND MONEY.

INCREASES SALES.

CUTS OUT DEAD STOCK.

PREVENTS WARPING.

TAKES UP SMALL SPACE.

FITS ANY SIZE BUSINESS, ESPECIALLY YOURS.



Announcement

WE HAVE opened offices at 29-33 West 38th Street (just West of Fifth Avenue), New York City, where we have our goods on display and ready for examination and comparison.

Our goods are sold under our own patents, applied patents and copyrights, or under arrangement of patents held by others, so that any dealer can handle our goods without fear of intimidation or law suit.

We claim and will demonstrate that the Pathé Discs (all double) are superior to anything on this market. They are made by the up-and-down cut system of recording, and play with a permanent round sapphire or a round diamond in place of a needle.

The Pathephone; as to mechanism, acoustics and style, is the best on the market. We make this statement unqualifiedly.

Our largest model machine will be equipped by us to play every make of Disc Record on the market, and play it perfectly.

Our plan is to sell goods in the usual way, through distributors and dealers. We shall limit the number of jobbers, and shall be very judicious in the selection and location of dealers.

We are now ready to receive the applications of jobbers and dealers and solicit your visit and correspondence.

PATHÉ FRÈRES PHONOGRAPH CO.



To the Trade

The Machines:

Beautiful in appearance, and the result of the combined talent and experience of the Pathé Frères vast establishments of Paris, Berlin, London, Petrograd and Vienna.



Model 175—\$175.00

The Records:

Sweet in tone—true to nature—rich in quality—full in volume. Many thousands of selections—Bands, Orchestras, Vocal and Instrumental, Opera Stars, Popular Singers, Dance Music, etc.

The PATHEPHONE and Pathé Double-Disc Records

SIZES AND PRICES OF DOUBLE RECORDS:

11½-inch	. . .	\$.75 to \$2.00
14 "	. . .	1.25 " 2.50
20 "	. . .	4.00



Model 15—\$15.00

Largest selection
of the latest
DANCE
RECORDS
endorsed by
MAURICE
and
FLORENCE
WALTON



Model 50—\$50.00

29-33 W. 38th STREET, NEW YORK



They are telling us that Columbia Record A-5595 is the greatest selling dance record ever issued.



(Write for "Music Money," a book "full of meat" for those dealers interested in quick and frequent turnover of capital.)

**Columbia Graphophone Company
Woolworth Building, New York**

MARKET FOR CHEAP "TALKERS."

Vice Consul-General Harry A. McBride, stationed at Boma, Belgian Congo, under the heading "Commercial Study of Portuguese West Africa," gives an interesting account of conditions in this far-away land in the October 1 issue of the "Daily Consular and Trade Reports."

Referring to the talking machine trade, Mr. McBride states as follows: "There is a good market for cheap talking machines, these being in use even by the poorer Portuguese families and the better-class natives. A few of the higher-priced American machines have been sold, but the trade demands an instrument retailing at \$10 to \$20. Records

WILL BUY DISC TALKING MACHINES

Wanted to buy a good job of disc talking machines and disc records, any make. We will buy supplies and horns. We pay spot cash. Address "O. C., 124," care The Talking Machine World, 220 So. State St., Chicago, Ill.

FOR SALE

5,000 brand new Columbia disc (single) records, must be sold at once. Price, 4c. each. Berliner Phonograph Co., Inc., Dept. 8, 140 East 4th St., New York.

AN OPPORTUNITY

Capitalist and business man wanted (or for sale) to handle patented invention (not an attachment), but consisting of an entirely new PHONOGRAPH TELEPHONE, etc., etc., instrument which eliminates all distortion of form or quality, superior to any known method on the market. The correct recording, reproducing and transmission of music at last made possible. Your business and financial responsibility a first requirement. For further particulars address Palys L. Chevrier, 1910 Hillcrest Road, Hollywood, Cal.

TALKING MACHINES WANTED

Wanted to buy, stock of talking machines. Must be up to date. Will pay cash. Address J. Venable, 975 Market St., San Francisco, Cal.

BUSINESS FOR SALE

FOR SALE.—Music business in a rapid growing resort city of South Florida. Good opportunity for one who can handle installments. Nearest dealer 66 miles. Country being settled rapidly. Address "Florida," care The Talking Machine World, 373 Fourth Ave., New York.

FOR SALE

One \$125.00 Victrola Grand Opera mechanical display now on exhibition in our show window. Big bargain for quick purchaser. Call, write or telephone E. G. Brown, Bayonne, N. J.

such as are supplied for Brazil and Portugal would find also a market if prices were right. At present all the records used are imported from France through the medium of Lisbon firms."

THE AGGRESSIVE MAN WINS

In the Battle for Trade This Fall and Winter, Says Thos. F. Green, General Manager of the Silas E. Pearsall Co., New York.

General Manager Thomas F. Green, of the Silas E. Pearsall Co., Victor distributors, 16 West Forty-sixth street, New York, who is widely known in the talking machine trade, is one of the most optimistic men when it comes to a discussion of the condition of business during the next few months. He believes that with the present adjustment in the banking system, the increased manufacturing orders and the wonderful crops there will be a prosperity which will result in a tremendous amount of Victor business.

"For those dealers going after business in an aggressive way," added Mr. Green, "the next few



Thomas F. Green.

months should show a lot of machine sales, to say nothing of the increased volume of record trade that usually comes in on the prosperity wave. The dealers using the Pearsall Victor service will be helped by securing a sufficient allotment of goods that will put them in a position of being able to fill most any demand made upon them. A well-stocked store not only gives the customer the impression that the store is a live one, but it permits the quick closing of sales by reason of giving the customer anything he wants on the minute. Frequently a prospect takes a year to make up his mind to own a Victrola, and when buying it in the morning wants the machine delivered in the afternoon, and it is necessary to have a good stock to be able to give the customer the right service."

In the organized mind there is an unfolding of the spiritual life, a constant search for better things, a wider vision of human needs, and a sympathetic effort to ameliorate the conditions of life. Serving the master mind of patriot, impelled Patrick Henry to utter the immortal words, "Give me liberty or give me death." The master mind of a general led Washington to his Yorktown and gave America its freedom.

A woman in Providence, addicted to the use of big words, was calling on a friend one afternoon, who complained of incessant pain in her back, whereupon the user of big words said: "I would consult Dr. Purzner for pains in the back. He's the finest bacteriologist that I ever knew of."

THOUSANDS ARE ENTERTAINED

By the Edison Disc Phonograph at the Entertainments Given on Tuesday and Thursday of Each Week at the Headquarters of the Prudential Insurance Co. in Newark.

A very notable feature of the various plans arranged by the Prudential Insurance Co. of America

day of each week, wherein the thousands of employees are able to enjoy some delightful programs which are contributed by the employees themselves.

Among the important attractions at these reunions is the use of a \$250 Edison disc phonograph, which with a large number of choice records were purchased by the company and turned over to the noontime committee for these entertainments. The illustration herewith shows the enormous



The Edison Disc Heard at Noontime Concerts of the Prudential Insurance Co.

for the entertainment of its employees at the head office in Newark, N. J., are the free entertainments arranged at the noon hour on Tuesday and Thurs-

day of each week, wherein the thousands of employees are able to enjoy some delightful programs which are contributed by the employees themselves. The illustration herewith shows the enormous crowd who have been aroused to enthusiasm by the Edison disc phonograph at these noontime entertainments.

A LIVE-WIRE READING STORE

Is That Conducted by Kline, Eppihimer & Co. —Has Attractive Columbia Quarters in Pennsylvania City—Long Established.

(Special to The Talking Machine World.)

READING, PA., October 7.—One of the live-wire merchandising establishments of this city is Kline, Eppihimer & Co. This concern has been in business for fifty-two years, and has been in its pres-



Kline, Eppihimer & Co.'s Attractive Display Rooms.

ent location on Penn Square during all these years. It also has the unique distinction of being one of the few old established department stores in this country wherein the originators of the firm are still living and actively interested in the business.

The Columbia department in this successful establishment is a very attractive one and as will



M. F. Elliot.

be seen by the accompanying illustration is well adapted to the holding of informal concerts. M. F. Elliot, manager of this department, is a keen student of all matters musical, and his hearty enthusiasm in Columbia quality and merit is well evidenced by

the rapid growth of his department. Mr. Elliot is most optimistic in his predictions for fall business, as he believes the next few months will be banner ones for Columbia machines and records in his territory.

INCREASE CAPITAL STOCK.

The Masterphone Corporation, manufacturer of the popular clarifying device known as the "Masterphone," has just moved its executive and sales offices to 286 Fifth avenue, New York.

The capital stock of the Masterphone Corporation was increased this week to \$100,000. Several changes have been made in the executive staff, C. M. Walsh having been elected secretary and treasurer and A. J. Wells appointed sales manager. M. B. Claussen continues as president.

REPORTS GOOD BUSINESS MONTH.

(Special to The Talking Machine World.)

BALTIMORE, MD., October 7.—J. L. Gibbons, new manager of the talking machine department of Stewart & Co., reports good business at the end of his first month. Mr. Gibbons succeeded J. A. Lappelle.

THE HERZOG MAGAZINE.

An interesting periodical known as the Herzog Magazine has now reached its fifth consecutive monthly issue. This publication contains considerable matter of musical interest, and is put forth by the Herzog Art Furniture Co., Saginaw, Mich.

AUCKLAND NOT UNPROGRESSIVE.

Harry W. Butler's Reply to Jake Graham's Criticism Sets Forth the Facts—Compliments for The World from New Zealand—Harry Lauder Spreads Himself—Hoot Mon!

(Special to The Talking Machine World.)

AUCKLAND, NEW ZEALAND, September 14.—The remarks of Jake Graham, the Liverpool dealer, about local dealers lacking progressiveness, which recently appeared in the course of his talk in The World, has been the subject of much comment here.

Harry W. Butler, of the gramophone department of the English & Foreign Piano Agency, Ltd., remarked in this connection: "Mr. Graham must remember that we are not living next door to the factories, the same as he is. If we want any records it takes us a fortnight to get them from the wholesale headquarters, which is in Sydney, 1,286 miles away. It must be also

remembered that there are as many people in Liverpool as we have in the whole of New Zealand, and he must not forget that the population tells a big tale. I think that with the stock we carry, over 10,000 H. M. V. and Twin disc records and every type of the same make of machines that there are very few signs of unprogressiveness. However, we are pleased to hear about our faults, and we shall try to improve to the satisfaction of Mr. Graham.

"By the way, I must compliment The Talking Machine World on its enterprise in keeping in touch with every part of the world. I consider it the best trade paper I have seen and look forward to its arrival with interest each month."

Some people may think that the Scotch are close-fisted in a money way, and that Harry Lauder is the patron saint of this clan, but Americans must be disabused of this idea, for at the Theater Royal the other night a large silk Union Jack was sold at auction, with Harry Lauder as assistant auctioneer, for the Mayor's Patriotic Fund. Mr. Lauder made a speech and aroused a great deal of enthusiasm. The first offer was ten guineas, but Mr. Lauder raised the price to fifty guineas, and later seventy guineas was offered, when he (Lauder) said he intended to take the flag back to Scotland if he got it, and he raised the bid to 100 guineas, at which figure the emblem was knocked down amidst cheers. Some local clubs are trying to repurchase the flag, but Mr. Lauder, with Scotch financial keenness, says the price is now £200.

CLAYTON BILL BECOMES A LAW.

The Clayton Anti-Trust bill, which, among other features, prohibits the fixing of prices to the retailer, was passed by the House of Representatives on October 7 and immediately went to the President for his signature, which made the measure a law. The purpose of the new law, the passage of which was strongly contested by the advocates of price maintenance, is designed as a supplement to the Sherman Anti-Trust law.

ENLARGES VICTROLA DEPARTMENT.

(Special to The Talking Machine World.)

NEW ORLEANS, LA., October 10.—The J. V. Dugan Piano Co., of this city, is featuring Victrolas so successfully that it has had to increase the capacity of its demonstrating and record rooms. The rooms are glass paneled and are soundproof.

THE UFFNER Sectional Record Cabinet



(Patented August 25, 1914.)

A new filing device for Talking Machine Records that fills a long felt want where objection is made against handling the great weight that is contained in Record Albums.

This system of filing and handling Records permits of great quickness and accuracy. The improved style of index furnished with each Cabinet is a strong feature.

The Cabinets are made strong and durable, containing four compartments: two for 12-in. Records and two for 10-in. Records. Capacity 60 Records. Each Cabinet contains a drawer 5 1/2 in. wide by 12 in. long for holding needles, cleaners, etc., as well as the index.

Finished handsomely in Mahogany Viennese leather, each compartment has gold-plated pulls, gold stamping and is initialed.

You take no chance in placing a sample order for these goods

MANUFACTURED ONLY BY

UFFNER ALBUM CO., 75 & 77 Grand Street, New York

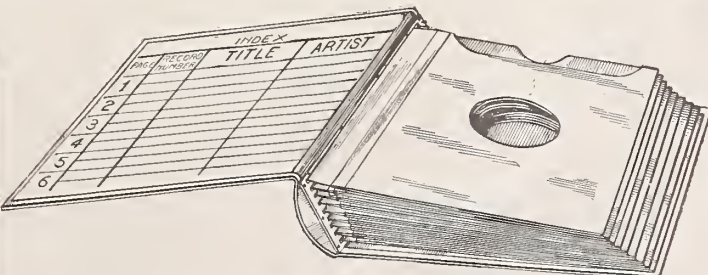

(Patented March 3, 1914.)

Also Makers of the **UFFNER NO GLUE ALBUM**

steel back binding which, for durability, has no equal. Made in two sizes to hold 12 and 16 Records respectively.

Cost no more than the old style album and worth double.

Include our Patent Album with your request for Cabinets.

10/15/14

SONORA PHONO

**“The Highest Class Talking
IS NOW READY**

The policy of this company has been to first create a demand for its instrument among the public and then appoint dealers throughout the country to enable us to fill that demand. The demand is now there, and the goods are ready.

Considered from a selling standpoint, the Sonora leads them all by far. It has more individual features than any other phonograph in existence. Where you might lose the sale of another machine you would surely sell a Sonora. Furthermore, when you sell a Sonora, you will be the only dealer to reap the benefit of future sales resulting from that one, as every Sonora dealer is given an exclusive territory, the size of which depends upon the amount of his initial purchase.

**“THE HIGHEST CLASS TALKING
WRITE US FOR OUR AGENCY PROPOSITION**

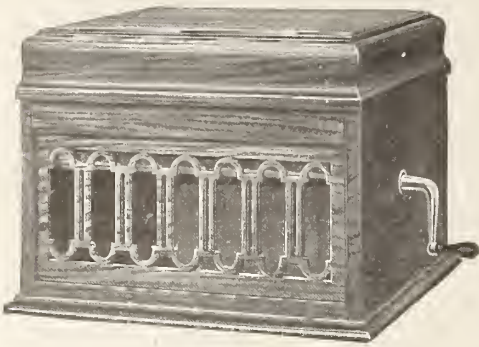

Price, \$35.00
Style “Jewel.”

10½" Turntable. Tone Modifier. Sapphire Needle. Double-spring Motor. Equipment for playing all makes of disc records in the world. (Diamond Needle \$5.00 extra; Multi-Playing Needle \$1.00 extra.) Trimmings Nickel-plated.

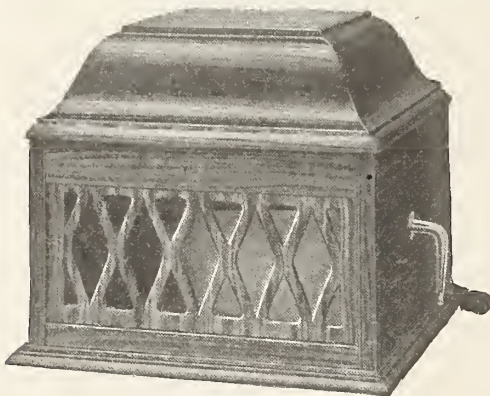

Price, \$50.00
Style “Excelsior.”

12" Turntable. Tone Modifier. Sapphire Needle. Double-spring Motor. Equipment for playing all makes of disc records in the world. (Diamond Needle \$5.00 extra; Multi-Playing Needle \$1.00 extra.) Trimmings Nickel-plated.

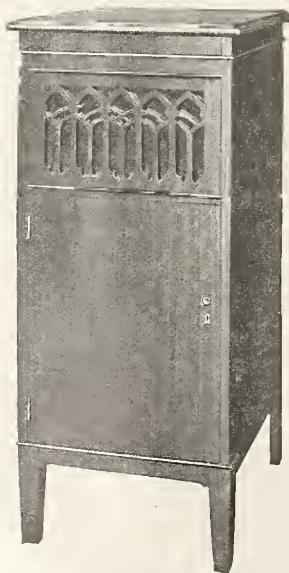

Price, \$100.00
Style “Imperial.”

12" Turntable. Extra Strong Double-spring Motor, Nickel-plated. Tone Modifier. Multi-Playing Needle. Sapphire Needle. Diamond Needle. Automatic Starter and Stopper. Equipment for playing all makes of disc records in the world. Trimmings Nickel-plated. Envelope Filing System, with capacity for holding 70 records. Compartment at bottom of cabinet for accessories.



Price, \$125.00
Style “Baby Grand.”

12" Turntable. Extra Strong Double-spring Motor, Nickel-plated. Tone Modifier. Multi-Playing Needle. Sapphire Needle. Diamond Needle. Automatic Starter and Stopper. Equipment for playing all makes of disc records in the world. Trimmings Nickel-plated. Envelope Filing System, with capacity for holding 70 records. Compartment at bottom of cabinet for accessories.



Price
Style

12" Turntable. Extra Strong Double-spring Motor, Nickel-plated. Tone Modifier. Multi-Playing Needle. Sapphire Needle. Diamond Needle. Automatic Starter and Stopper. Equipment for playing all makes of disc records in the world. Trimmings Nickel-plated. Envelope Filing System, with capacity for holding 70 records. Compartment at bottom of cabinet for accessories.

Be first in introducing this needle in your city and have the advantage over your competitors.

It enables you to draw new trade to your store.

Exclusive representation granted.

**THE SONORA JEWEL
A RELIABLE AND MOVABLE**

The Beginning of the end of
WRITE FOR DESCRIPTION

**SONORA PHONOGRAPHS
57 READE STREET, NEW YORK**

(The attention of our Legal Department will be called to any individual, firm or corporation who attempts to sell or use the name of the Sonora Phonograph Company without its consent.)

SONORA PHONOGRAPH

"Machine in the World"

FOR THE TRADE

The Sonora Phonograph possesses these great advantages:
IT IS THE ONLY PHONOGRAPH WHICH WILL PLAY ALL MAKES OF DISC RECORDS PERFECTLY. This means the new Diamond Disc, the Sapphire and ordinary Steel Needle records. Others have made this claim, but could not prove it. The Sonora makes the claim and proves it.
IT IS SUPERIOR TO ALL OTHERS IN TONE-QUALITY, AND IS EQUIPPED WITH A PERFECT TONE MODIFIER AND AUTOMATIC STARTER AND STOPPER.
IT EXCELS IN MECHANICAL CONSTRUCTION, QUALITY OF MOTORS, CABINET DESIGN AND INDIVIDUALITY. IT IS THE ONLY PHONOGRAPH WHICH CAN BE CALLED

"MACHINE IN THE WORLD"

AND NEW ILLUSTRATED CATALOGUE.

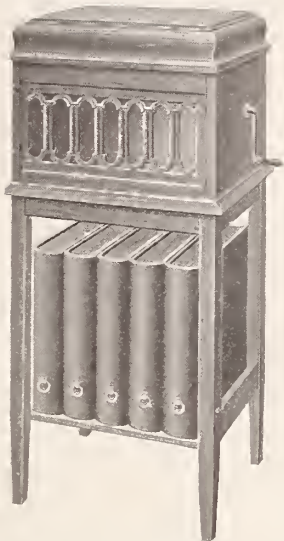

Price, \$40.00
 Style "Jewel Combination."
 (Albums Extra)

10½" Turntable. Tone Modifier. Sapphire Needle. Double-spring Motor. Equipment for playing all makes of disc records in the world. (Diamond Needle \$5.00 extra. Multi-Playing Needle \$1.00 extra.) Trimmings Nickel-plated.

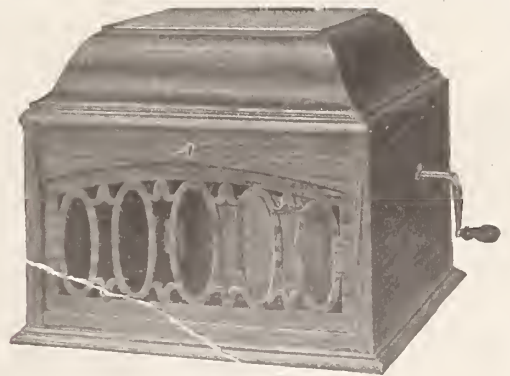

Price, \$75.00
 Style "Peerless."

12" Turntable. Extra Strong Double-spring Motor, Nickel-plated. Tone Modifier. Sapphire Needle. Multi-Playing Needle. Diamond Needle. Automatic Starter and Stopper. Equipment for playing all makes of disc records in the world. Trimmings Nickel-plated.



Price, \$150.00
 Style "Rosary."

12" Turntable. Extra Heavy Double-spring Motor, playing half an hour, or ten 10" records, in one winding. Tone Modifier. Multi-Playing Needle. Sapphire Needle. Diamond Needle. Automatic Starter and Stopper. Equipment for playing all makes of disc records in the world. Trimmings Nickel-plated. Envelope Filing System, with capacity for holding 70 records. Compartment at bottom of cabinet for accessories.



Price, \$200.00
 Style "Grand."

12" Turntable. Extra Heavy Double-spring Motor, playing half an hour, or ten 10" records, in one winding. Tone Modifier. Sapphire Needle. Diamond Needle. Automatic Starter and Stopper. Multi-Playing Needle. Equipment for playing all makes of disc records in the world. Trimmings Gold-plated. Envelope Filing System, with capacity for holding 160 records.

MULTI-PLAYING NEEDLE

IMPROVED SUBSTITUTE

Equal of the Steel Needle

COMPARE AND PRICES TO

SONORA CORPORATION, Mfrs.

GEO. E. BRIGHTSON, Pres.

(Do not wilfully making false statements regarding the merits of this needle.)

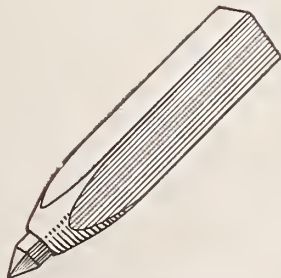

Patents Pending

Price, \$1.00

THE TRADE IN PHILADELPHIA AND LOCALITY

(Special to The Talking Machine World.)

PHILADELPHIA, PA., October 8.—There is a diversity of opinion as to the talking machine business in Philadelphia during September. Several of the firms have had a better business than they enjoyed during September of 1913, while others say they have not done quite as well, and attribute their lack of success to the two spells of exceedingly hot weather that were encountered during that month. When the weather was cool business was good, but the life went right out with it when the heat attacked the city.

Dealers Generally Optimistic.

The dealers are quite optimistic as to the fall and winter trade, and already they believe they see signs of active business. They are all buying heavily, not only in machines, but in records, dance records still having the call, as evidence is shown that there will be no lessening in this popular

amusement because the dancing schools are filling up earlier than usual.

Edison Latest, the "Telescribe," Shown.

Thomas A. Edison's latest invention, an instrument for the recording of telephone conversations, was demonstrated in Philadelphia last week by Nelson C. Durand, of the Edison laboratory, of East Orange. The demonstration was made at the warerooms of Louis Buehn, 825 Arch street. Mr. Edison calls this instrument the "telescribe." It is connected with an ordinary desk phone and transcribes conversations to a dictating machine, where they are recorded on a wax cylinder after the manner phonograph records are made. The telescribe was described in The World last month.

Mr. Buehn had sent out a number of invitations to prominent firms in this city to see the demonstration of this new invention, and there was a good representation present.

Louis Buehn Reports Improved Business.

Louis Buehn reports that his business has been very satisfactory, and it was infinitely better in September than it was last year. He enjoyed an increase of at least 50 per cent., a great deal of which was machine stocks anticipating a big holiday business. Mr. Buehn's personal opinion is, however, that while the dealers generally are making extensive preparations for a big trade, he is of the opinion that we are not going to have such a big retail business as some may expect.

Machines, Mr. Buehn says, are coming in very fine and, in fact, the companies are sort of swamping the jobbers. Records are also coming in very much better. He says the dance music still has a strong hold, but aside from that he believes there will be little sold but the Red Seal records.

Dance and Classic Records at Heppe's.

The past September was as good as last year at C. J. Heppe & Son, says Manager Elwell. He says the machines from the Victor are coming through all right, but the record stocks are a little slow. He says it looks as if the dance records were going to keep up, but that there is also a great amount of classic stuff selling.

Harry Cake Safe Home from Europe.

Harry Cake, of Pottsville, who handles talking machines in that city, was in Philadelphia on his way home from Europe. He has some interesting experiences to relate, having been caught in Ger-

many at the outstart. He was very seriously handicapped in getting accommodations and getting away, for the reason that his "talking machine" money was no good and that they even gave him no opportunity to spend any of it. He was helped out, however, through the Cook's Tourist Agency.

Big Stock on Hand at Gimbel's.

Gimbel Bros. report that they have about run even with last year in September. They have at present a larger stock than they have ever before carried in the history of their department, which indicates that they take an optimistic view of conditions. Their biggest business in records at present is for the dance numbers.

Some Original Advertising Matter.

Messrs. Blake and Burkhart, who conduct the Edison Shop at Eleventh and Walnut streets, are getting out some innovations in advertising matter in the way of circulars, of envelopes and of wrappers. Everything that goes out from the store is labeled "The Edison Shop." Both members of the firm were in East Orange last week and spent some time going over the factory. They have taken on a new salesman, Horace G. Bentley, who will be an outside man. In every delivery they make they place considerable advertising matter.

Have Handsome Warerooms.

The Talking Machine Co. on South Broad street has its warerooms completed, and the large marble stairway leading from the first to the second floor is very attractive and lends an imposing appearance to its otherwise very handsome warerooms.

Lively Demand for Columbia Line.

Manager Eckhardt, of the Pennsylvania Talking Machine Co.—the Columbia jobber of this city—says that his house had a very remarkable increase in business in September, and that it has "a lot of good meat stirred up for this month." Thus far it has gone ahead every month this year, notwithstanding that its business last year was most gratifying. "Fortunately," says Mr. Eckhardt, "we have not discovered that there is a war going on. If you will allow it to interfere with your business it is going to do so, but I made up my mind I would do all my war talk at home, and when I left home I would shake it off, and I have asked all my people to do the same."

Mr. Eckhardt says that he has been having a

(Continued on page 43.)

Largest Stock of Victor Records and Victrolas in Pennsylvania

Orders Filled
IMMEDIATELY
Upon Receipt

Give Us a Trial and
be Convinced.

Penn Phonograph Co.
17 South Ninth Street
Opposite Post Office PHILA., PA.

VICTOR

A complete line of Victor products, from the smallest repair part to the biggest model of machine. Every shipment made promptly.

EDISON

Cylinder goods, machines and records; full stocks and immediate deliveries. A good popular-priced line for most any territory.

Louis Buehn Philadelphia

THE TRADE IN BALTIMORE AND VICINITY

(Special to The Talking Machine World.)

BALTIMORE, Md., October 6.—The talking machine business is hitting up its usual fast stride with the result that all the dealers report excellent prospects for the fall and winter, and especially for the holiday trade. Most, if not all of them, are stocking up ahead of time to be in position to handle each and every customer during the holidays and to disappoint none.

The additional space added by E. F. Droop & Sons Co. was not put into service any too soon, for the firm has a big stock of Victors and Edisons on hand for the heavy demands that continue to pour in. Manager W. C. Roberts reports a very good September and has every reason to believe that this will be his banner year.

Joseph Fink, proprietor of the Fink Talking Machine Co., reports good sales with the Victor and Columbia lines at both his main store and his new branch store. Business is picking up nicely.

F. A. Dennison, manager of the branch store of the Columbia Graphophone Co., shows by reports and statistics that the various styles of Columbia instruments are just as popular as ever, and are bringing in good sales both in the city and on the road.

The Sanders & Stayman Co., Inc., reports sales for September with the Columbia and Victor lines to have been right up to the standard, and they look for a continuance of the good results.

H. R. Eisenbrandt & Sons are also in the band wagon with a line of good sales of Victors, which they handle exclusively.

The department stores, such as Stewart & Co., Gomprecht & Beresch and Hochschild, Kohn & Co., have good reports to make with regard to their talking machine departments.

ADJUST EFFORTS TO OBSTACLES.

Salesmen Must Know More About Their Goods Than the Customer, and Be Able to Prove It—Making Adjustments.

"Back of everything you sell there is something bigger than the article itself," writes George H. Eberhard, the prominent service expert. "It's the proposition—it's all that goes to make the sale possible in the mind of the customer. Salesmen

must know more about the proposition back of the goods they have to sell than the customer, if they want to enjoy the customer's confidence, and they must get his confidence and retain it if they're building up permanent trade.

"Salesmen must be prepared at any and all times to answer in several different ways every question about their goods and the proposition that makes each item a sales factor; so salesmen should be continually on the alert forestalling possible questions with the answers they would give if they were called on at a moment's notice to answer them. A salesman should treat his mind as he would a valuable race horse. Keep it in good

condition and warm it up occasionally with trial practice.

"Salesmen all have mental or physical defects or weaknesses. They know of these defects, and knowing, they should give thanks. Known defects are signals crying out to us to correct and control the weak spots in our selling armor. If you are loud in your general conversation, and you know it, the answer is, 'Tone it down.' If you lack poise, the answer is, 'Practice control.' If you're slow to collect your thoughts under fire of questions—prepare, practice, study, be ready. Don't let any man be a better salesman than you are.

THE TRADE IN PHILADELPHIA.

(Continued from page 42.)

splendid business with the dictagraph. J. Westervelt has full charge of that end of the business, not only as inside man, but also as manager of salesmen. The firm has closed a most substantial order for these machines with the Du Pont Powder people and with the Lanston Monotype Co.

De Angelis Heads Cunningham Department.

John De Angelis, a cousin of Jefferson De Angelis, the comedian, has been made the manager of the Edison phonograph department at Cunningshams. He sold the Edison records originally direct for Edison people in Orange. Mr. De Angelis

came to this city from Winnipeg. He says he thinks things look very bright for the Edison here this winter. A. C. Ireton, manager of sales, and C. P. Chew, both Edison men, were in Philadelphia the past week. They announce that they will send a corps of demonstrators over here shortly and give recitals, "after which," he says, "the enterprising dealers here are supposed to show the Philadelphia people the advantages and the way to secure one of the fine Edison talkers."

Many New Columbia Dealers.

"The new \$85, 1915 Columbia 'Leader' machine, has been received at the Philadelphia store," says Mr. Eckhardt, "and it has created quite a furore. It has been received very enthusiastically by the

trade and we are able to sell them faster than we can get them at the present time. I believe the new De Luxe, which is just out, is also going to be a winner." The Metropolitan Phonograph Co., of Reading, has begun extensive handling of the Columbia product, and will handle the Columbia exclusively. The Pennsylvania Co. has put on a great number of smaller accounts and has averaged a new contract a day during the summer months, and its territory is pretty well covered and it has had to turn down a number of applicants. It is negotiating for an important contract in Camden, which it expects to close in a few days. It has just closed a contract to handle the Columbia with Painter & Ewing, the piano dealers of this city.

READY REFERENCE OF GENERAL SUPPLIES

DEALERS

Send for our "Trial Proposition" on the Regina Hexaphone—the latest and best paying popular priced coin-operated instrument for use in public places.



211 Marbridge Bldg., 34th St. and Broadway, New York City
Manufacturers of Regina Music Boxes; Reginaphones;
Coin-operated Mandolin Orchestrions; Vacuum
Cleaners and other specialties.

Mermod & Co.

505 Fifth Avenue New York

Manufacturers of

Talking Machine Supplies

Motors—Sapphire Points

Diamond Points a Specialty

Keep Your Record Stock with



Costs about \$2.00 for 250 records for 50 years
Send for 20-page catalog

THE SYRACUSE WIRE WORKS,
SYRACUSE NEW YORK

Will You Score this Season?



YOU'VE been working all season building up an organization to give the best possible service.

You've been advertising extensively—you've been working out systems to handle your business—to *what end?*

You Know This Will Be Your Biggest Victor Year

You're congratulating yourself that you're in a growing—booming—successful business—but *you can't reach your goal without the stock.*

Ours is the largest, most complete Victor stock in the country—we're prepared to take care of you. We'll help you make your goal.

THE TALKING MACHINE COMPANY

12 NORTH MICHIGAN AVENUE - - - - CHICAGO

FROM OUR CHICAGO HEADQUARTERS

E. P. VAN HARLINGEN, Manager
HENRY S. KINGWILL, Associate

World Office
Consumers' Bldg., 220 South State St., Chicago
Telephone: Wabash 5774

(Special to The Talking Machine World.)

CHICAGO, ILL., October 9.—The local talking machine trade is enjoying the first fruits of the fall season. A very decided increase in sales is reported all along the Avenue, and in every talking machine store the opinion is given that the fall of 1914 will be a most profitable one despite the general adverse conditions which prevail and which have so seriously impaired so many other industries.

The heaviest machines being sold are, of course, the ever-popular styles that retail around \$100, but numerous disposals of the largest styles of machines are reported on all sides.

The record situation, while it does not show as much improvement, perhaps, as the improvement in the sale of machines, is nevertheless good. The dancing fad continues to contribute its beneficence, but records now called for are for the "fox trot," which dance is the successor to the tango. The fox trot is said to be very much the same as the tango, but the time is doubled.

O'Neill-James Gets Pathé Agency.

L. L. Leeds, of the New York office of Pathé Frères, while on a recent visit to Chicago, announced that his company had placed the agency for its goods in Chicago and Western territory with the O'Neill-James Co., of Chicago.

A. J. O'Neill said to The World: "We are very much pleased at securing the Pathé line. We think it is a winner, and I look for every success with it here in the West. I start on my first trip in connection with our new business in a few days and will visit St. Louis, Omaha and cities in the Northwest.

Hold Formal Opening.

Rolf Hammer, famous Norwegian singer and maker of many of the popular Edison records, was a visitor last week to the shop of James I. Lyons. Mr. Lyons was also visited by Otto Clausen, another Norwegian singer of the same company, who has contributed many of the popular issues in the Norwegian division of the Edison library.

Mr. Lyons was one of the exhibitors at the recent Household Show at the Cotiseum, where he showed in addition to an elaborate display of the Edison Amberol machines, the Victor and Columbia machines and records.

Singers Visit Dealer.

The enlarged and improved record department

of the Phonograph Co., local Edison representative, was opened September 26 to a large crowd of interested patrons. The latter availed themselves of the many new facilities and privileges of the Edison shops and incidentally invested heavily in records and machines. The affair was quite social in tone. Tea and light refreshments were served.

L. A. Sutfin is the new general traveler for the Phonograph Co. Mr. Sutfin is at the present time making a trip through Southern Illinois, calling on Edison dealers and prospective Edison dealers.

Inaugurate Instalment Business.

Two of Chicago's largest department stores, namely, Siegel Cooper & Co. and the Fair, have decided to institute the instalment system in their respective departments. This is an entirely new departure for the Fair, although Siegel Cooper & Co. did it at one time and then decided to discontinue it.

General Manager George W. Montgomery, of the Fair, made his decision during the past week following a visit by Clifford R. Ely, special representative of the Columbia Graphophone Co. Mr. Ely disposed of a large stock of Columbia goods to Mr. Montgomery, and it was following this that the decision to operate the instalment business was made. The talking machine department of the Fair will be greatly enlarged by a number of large booths and the business will be actively pushed.

The talking machine department of Siegel Cooper & Co. will be removed from the fourth to the third floor, and Manager Sandeberg is planning an active campaign for the fall months. As a first step he placed a large order for Columbia goods with Mr. Ely also. Mr. Ely deserves much credit for the business-like way in which he handled these deals. There are now six of the eight large department stores on State street who are Columbia dealers. They are Siegel Cooper & Co., Rothschilds, the Fair, Hillman's, the Boston Store and Marshall Field & Co. The details of the adoption by Marshall Field & Co. of the Columbia line will be found in another part of this paper.

Business in Northwest Good.

R. J. Keith, manager of the Talking Machine Co., spent a few days this week on a trip through the Northwest. While at Minneapolis Mr. Keith

was entertained by Archie Mattheis, dealer in that city, who showed him about the city and took him for a motor trip through the beautiful lake country that surrounds it.

"I found things in the Northwest especially good," said Mr. Keith. "A big business is undoubtedly assured for that section of the country this year, and all seem to realize it, as they are stocking up heavily. Grain crops were tremendous and they are enjoying one of the biggest businesses in their history.

"We closed our business for September with a substantial gain over September of last year, and so far this month are continuing to go at a good pace. There seems to be a considerable feeling of confidence, and despite the big war we are finding dealers to be in an optimistic frame of mind."

Wade Business Double.

S. O. Wade, of Wade & Wade, announces that his company's business for September, 1914, was just double that of September, 1913. "This is very encouraging to us," said Mr. Wade, "and in our opinion shows that dealers are realizing the advantages of handling a first-class needle cutter such as we believe ours to be. A cutter that pleases customers and a cutter that users recommend to their friends is naturally much in demand."

Rothschild in Dance Program.

Rothschild's Department Store is offering a novelty to its customers that is more than successful. B. F. Dvorak, in charge of the department, arranged and is now giving concerts which include not only talking machines, but which also includes the violin and player-piano, and the three in concert. Mr. Dvorak secured Miss Dunn and Mr. King, society dancers, to illustrate the latest steps to the music of the talker and the player-piano, and the concerts which are given twice a week are being attended by increasing numbers all the time. The first program was made up of eight numbers, and those present remained from start to finish.

New Victor Store.

S. K. Tureck, 3223 West Twenty-second street, has just placed a large order of Victor goods with the Talking Machine Co., and will open a fine store.

Whitman to Indianapolis.

H. Whitman, formerly floor salesman for the Talking Machine Co., was selected some time ago to take charge of the new Victrola department

(Continued on page 47.)

THE WADE—THE PRACTICAL—THE WADE Fibre Needle Cutter

The WADE embodies the right principle, worked out through long experience. It is simple, durable and accurate. It trims the needle at an angle resulting in the best tone. The WADE cutters are made of the best steel and are absolutely guaranteed.

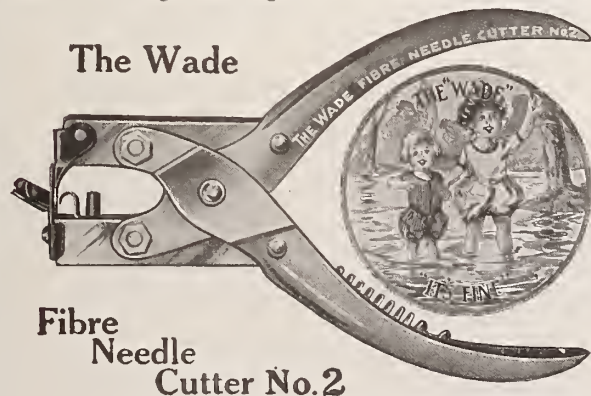

The Wade
Fibre
Needle
Cutter No. 2

The WADE is the most economical cutter. It has a self-acting stop, which prevents waste and enables one to get from 12 to 15 perfect playing points. No. 2 has a double action, making it especially easy to operate and affording the most powerful cut of any tool made. No. 1 is a very popular cutter which has given excellent service.

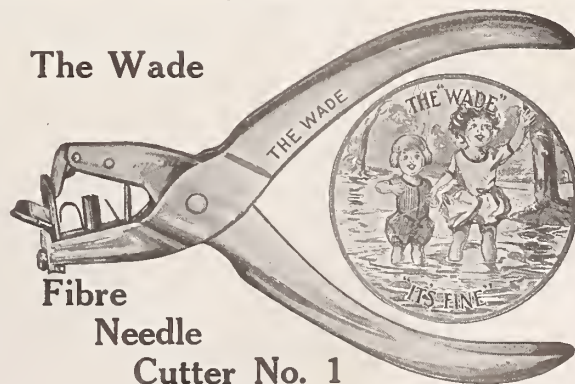

The Wade
Fibre
Needle
Cutter No. 1

RETAIL PRICES—No. 1, \$1.50; No. 2, \$2.00

Order from your regular Distributor—we sell to Jobbers only

WADE & WADE,

3807 Lake Park Ave.
CHICAGO, ILL.

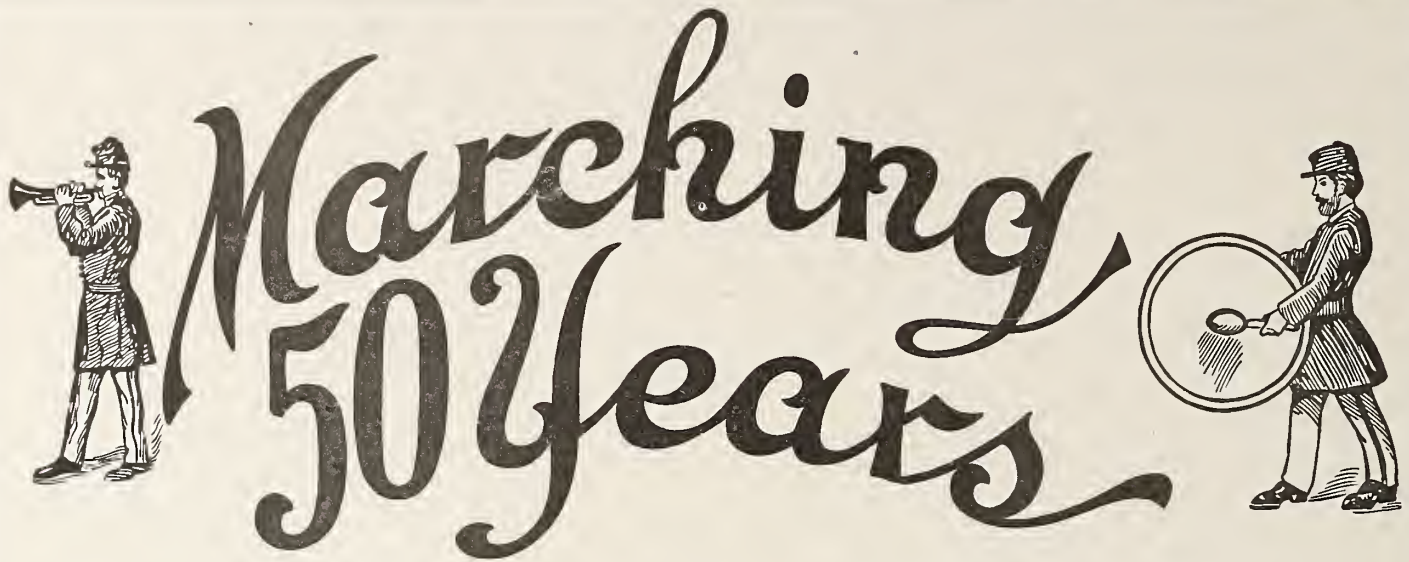

Marching 50 Years

THIS house opened its doors to the public in October, 1864. It started with three great ideas—First, to sell everything known in music; Secondly, to give the public better service and, Thirdly, to tell the people about it. These are cardinal principles with us today.

When the Talking Machine business was in its infancy, many years ago, we gave the whole proposition the most careful study with the result that we delivered our opinion to the effect that the Talking Machine, in time, would prove a wonderful musical instrument and that its manufacture and sale should be along artistic musical lines. Today, we are firmer than ever in our belief that every effort should be put forth to keep the Talking Machine in its well-earned place as the ideal ever-ready home entertainer and orchestra. To this end we strive to make our Victor Service the kind that gives real satisfaction to all concerned—satisfaction in a pressed-down and flowing-over measure.

Lyons & Healy

CHICAGO

FROM OUR CHICAGO HEADQUARTERS—(Continued from page 45).

of the Pearson Piano Co. of Indianapolis, Ind., and latest reports are that he is advancing rapidly in his new work. A. G. Griffiths, Indianapolis, Ind., is the floor salesman in his stead.

Takes on Talking Machine Line.

The Central Piano Co., Jackson boulevard and Wabash avenue, which is headed by Raymond J. Healy, is taking on a complete line of talking machines in the large basement of the building, and will install a nice outfit of record racks and sound-proof booths.

Premier Progress.

Local officials of the recently organized Premier Cabinet Co., Montoursville, Pa., report an excellent business following the first month's work. The Premier Cabinet Co., which is headed by George M. Willson, has placed upon the market a line of talking machines which are distinctively novel and apparently very meritorious. Two styles have already been placed on the market, one being a cabinet machine, while the other instrument is of a portable model, designed for use on a table or separate cabinet. Located in one-half of the machine is the twelve-inch turntable and motor, both of a new and excellent pattern. The tone arm proceeds to the rear of and to the side of the mechanism, the sound chamber widening out into the other half of the machine. Cane panels cover the front of the sound chamber.

The Premier is an all 'round machine, as it is regularly fitted to play any lateral cut record, and by the addition of an ingenious attachment, provided with a sapphire or diamond needle, it will play equally well any type of vertical cut record.

It is announced by officials of the company that work is already proceeding on other styles, and that the company will issue a new style every six weeks until the line contains seven instruments, affording a wide range in price. It is planned that different styles of furniture architecture such as Sheraton, Mission, etc., be followed. They will be finished in mahogany, golden oak, fumed oak and other woods. The larger cabinet machines are equipped with a filing space capable of storing 200 records.

Messrs. Allmann and Chamberlain represent the Premier Co. in Chicago and the West. C. E. Keen, traveling representative, is now on a trip through the Southwest, introducing the Premier to the dealers of that territory.

Personals and Visitors.

George P. Ellis, of the Talking Machine Co., returned recently from a two weeks' vacation which he spent at Bass Lake, Ind. Previous to this Mr. Ellis made a trip to Indianapolis, where he aided in the presentation of dancing demonstrations given in the New York Store in that city. Mr. Ellis also went to Grand Rapids, Mich., where he assisted in putting on a dancing exhibition at Wuerzberg's.

Will A. Young and wife, of Fort Wayne, Ind., were recent visitors to the local trade, as was A. E. Shea, manager of the Victrola department of the L. S. Ayers Co., Indianapolis.

Other recent visitors to the local trade were H. S. Kesler, of La Porte, Ind.; A. F. De Forest, Decatur, Ill., and L. M. Knickerbocker, of the Lion Dry Goods Co., Toledo, O.

E. F. (Doc) O'Neil, one of the chief assistants to George Ornstein, manager of the traveling department of the Victor Co., was a recent visitor.

Some Edison dealers recently visiting Chicago were A. H. Steinberg, Peotone, Ill.; F. A. Cope land, of Elgin, Ill.; and James Taylor, of Chadwig, Ill.

H. H. Blish, of Harger & Blish, of Des Moines, Ia., was one of the prominent Edison jobbers passing through Chicago last week on his way to the Edison jobbers' convention in New York.

Paul Seegar, of the Edmund Gram Co., of Milwaukee, was a recent visitor.

V. B. Taylor, formerly traveler for the Victor Talking Machine Co., has made new connections with the Koerber-Brenner Co., Victor distributors

of St. Louis. Mr. Taylor is widely known in this part of the country.

Some New Dealers.

A number of new Victor dealers are reported from various points in the Middle West, among them being the Emerson Piano Co., Decatur, Ill.; the Mohr Hardware & Furniture Co., Bay City, Mich., and the Wayne Music Co., of Indianapolis, Ind. The Wilkinson Piano Co., of Joliet, Ill., is also increasing its stock very largely and improving its department in many ways.

Musically Inclined Puppykins.

The accompanying illustration is a reproduction from a photograph of Puppykins, the highly intelligent dog belonging to Archie Mattheis, proprietor of the Talking Machine Co. of Minneapolis, Minn. Puppykins is listening to a whistling record on the

**Introducing "Puppykins."**

Victrola. He is a very discriminating dog in his musical tastes, but when he hears anything that interests him he gets as close to it as possible. Several articles on Pupkins and his musical proclivities have appeared in the Minneapolis and St. Paul papers.

Invents New Needle.

A. H. Rintelman, piano dealer of 209 South State street, has applied for a patent on a one-piece needle that he claims has many superior features. It is triangular in form, with the three surfaces concave. This construction affords three points to the end of the needle, thus making it practically a permanent needle, as it is of a composition that is extremely hard.

"It affords a perfect transmission," said Mr. Rintelman, "because of certain composite metal and mineral that is contained within it, and will withstand the various changes of temperature without expansion or contraction."

Columbia Display at Home Exposition.

The accompanying illustration is of the Columbia booth which was one of the features of the Home Exposition given at the Coliseum in this city the latter part of September. The exhibit

**The Columbia Booth at Home Exposition.**

showed the complete Columbia line, and those in attendance had plenty of opportunities to demonstrate the Columbia tone, inasmuch as the exhibit was well surrounded the greater part of the time.

A. T. Boland, manager of the retail department of the local Columbia Co., designed the booth and was in charge of it. Assisting him were H. H. Goul and E. E. Cohan. Mr. Boland said that the exhibit was a big success, as there were not only numerous sales made, but a large number of excellent prospects were secured.

Prominent Victor Visitors.

George Ornstein, manager of traveling salesman of the Victor Talking Machine Co., Camden, N. J., was a visitor to the local trade a few days ago. Mr. Ornstein reported that he was finding business good in every direction that he traveled.

V. W. Moody in Chicago.

V. W. Moody, sales manager of the New York Talking Machine Co., stopped in Chicago for a day or two between the course of a vacation that he is spending in the West. Mr. Moody was welcomed here by a large number of friends who were acquainted with him when he was connected with the Talking Machine Co., of Chicago.

Cabinets in Demand.

The Salter Mfg. Co. is continuing to receive a brisk demand for almost all sizes of its varied line of record cabinets. The display of these cabinets has informed the public that such things exist, and as a result many owners of smaller machines are taking advantage of it.

Cheney Talking Machine Co. Developments.

The incorporation last month of the Cheney Talking Machine Co., under the laws of Illinois, with capital stock of \$100,000, all paid in, marked the final step in the organization of the project for the manufacture and marketing of the talking ma-

**Forest Cheney.**

chines invented by Forest Cheney, the first announcement of which was published in The Talking Machine World nearly a year ago.

The laboratory work connected with the development and perfecting of the Cheney machine has all been completed and the new company is prepared to enter the manufacturing field on a large scale. The controlling interest in the new company is held by the officers of Marshall Field & Co., which company will have the retail selling agency for the Cheney talking machines in Chicago. The details regarding the new department in the Marshall Field & Co. store appear in a special story

(Continued on page 48.)

FROM OUR CHICAGO HEADQUARTERS—(Continued from page 47).

published elsewhere in The World this month.

In the West the general jobbing rights for the Cheney product will be held by the wholesale department of Marshall Field & Co., and jobbing rights in the music trade by the George P. Bent Co., the prominent piano house. Other jobbers will be appointed to cover remaining sections of

the country as soon as arrangements can be made to that end.

George H. Bent, for fifteen years manager of the retail department of the George P. Bent Co., in this city, has resigned to become manager of the Pacific Coast jobbing rights for the new Cheney talking machine.

NEW HOME FOR LYON & HEALY AN IMPOSING STRUCTURE.

Nine-Story Building at Corner of Wabash Avenue and Jackson Boulevard to Include Numerous Original and Convenient Features—the Architect's Description.

(Special to The Talking Machine World.)

CHICAGO, ILL., October 9.—According to the architect's drawing and the announced plans for the new Lyon & Healy building, to be erected at the northeast corner of Wabash avenue and Jackson boulevard, this city, it will be a most imposing and conveniently arranged structure. The building will occupy a site 96 feet on Wabash avenue and 171 feet on Jackson boulevard, and the actual work on the structure will begin early next spring. The accompanying illustration affords an excellent idea of the general exterior appearance of the new Lyon & Healy building when completed.

The architects, Marshall & Fox, have incorporated many original and valuable features in the design for the building, and in their description of the structure state that it will be nine stories

feeling in its columns, pilasters and vaulted ceiling, all being finished in the natural caen stone.

There will be a mezzanine floor between the first and second floors with balcony railings looking over the main portion of the store.

The basement and upper floors of the Lyon & Healy space will be served by three large elevators for the use of the public and by two freight elevators running the full height. There will be two elevators from the backing-in space on the alley running to the basement, thus giving very ample elevator service.

In addition, there will be a spiral parcel chute, dumb waiters, etc., all the details being worked out carefully to provide quick service.

The upper floors have been divided into large sales rooms, etc., for the pianos, musical instruments, etc. The general finish of the interior will be equal to that of the best office building, that is, mahogany trim, marble floors and wainscot, ample toilet facilities, etc.

The entire Lyon & Healy space will be provided with a ventilating system to supply fresh air for all departments.

In this connection it is interesting to remember that it is just fifty years since Lyon & Healy opened a music store on Washington street opposite the Court House, where the old Chicago Opera House was situated.

The big business was founded by the late P. J. Healy and its management to-day is in the hands of his sons and associates.

Lyon & Healy, to commemorate the semi-centennial of the establish-

ment of the house, sent out attractively engraved cards, announcing the fact to its friends in the trade. The card was accompanied by a photographic reproduction of the first Lyon & Healy advertisement in the Chicago "Tribune" of November 4, 1864, published at a time when the talking machine had not been thought of.

OPENS ENLARGED STORE.

(Special to The Talking Machine World.)

CHICAGO, ILL., October 9.—The Wilson Avenue Talking Machine Co. of this city, of which Mr. Cullen is owner and R. O. Fenton is manager, has

BOOK ON "PRICE STANDARDIZATION."

Interesting and Instructive Volume by Charles T. Terry Being Distributed Among Its Dealers by the Victor Co., Accompanied by Letter Emphasizing Importance.

Victor dealers throughout the country received last week from the Victor Talking Machine Co. a copy of an interesting and informative booklet entitled "Price Standardization," written by Charles T. Terry, of New York. This little volume, which is issued by the American Fair Trade League, was compiled to present in compact form "arguments and authorities establishing that a law should be enacted by Congress which would permit a manufacturer to fix by contract the retail selling price of his product, where such product is either a patented or trade-marked article, or is otherwise identified as a standard article of merchandise distinctly branded either under the copyright act or the common law."

With this purpose in view, "Price Standardization" discusses the tremendous value of price maintenance from every conceivable standpoint, and the recommendation by the Victor Co. that its dealers give the booklet their closest attention was well worth carrying out.

The letter to the dealers accompanying this publication read in part as follows:

"The justice of price standardization is becoming more evident every day. Every day it is gaining adherents and every day evidence of its desirability accumulates.

"The fixed price stayed fixed, when, as a result of the war, prices generally were advanced in this country. In Paris, when siege seemed imminent, people began to buy provisions. They went to the fixed price stores to do it—and French thrift is proverbial.

"Last week's issue of the Saturday Evening Post contained a full page argument in favor of price standardization, and much campaigning of the same sort is being done by other publications.

"Victor dealers should be in the future, as they have been in the past, at the forefront of the movement. A thorough understanding of the case is most important. Indeed, there is only one thing of greater importance, and that is that you should lose no opportunity to express your wishes and your beliefs to your Congressmen and Senators. That is the only channel through which legislative assistance can be received, and the sole purpose of electing members of Congress is that they should represent and provide for the wishes of their constituents, whenever such wishes are in conformity with the public good."

Experience is the best teacher, but don't rub it in on the man who commits bigamy.

Much of the speech that is heard in this time is not even silver, but only sounding brass.

just opened its enlarged store, 1010 Wilson avenue. It added another storeroom and fixed the whole up in excellent shape. The accompanying photograph shows the enlarged quarters on the opening day with the show windows attractively decorated for the occasion.

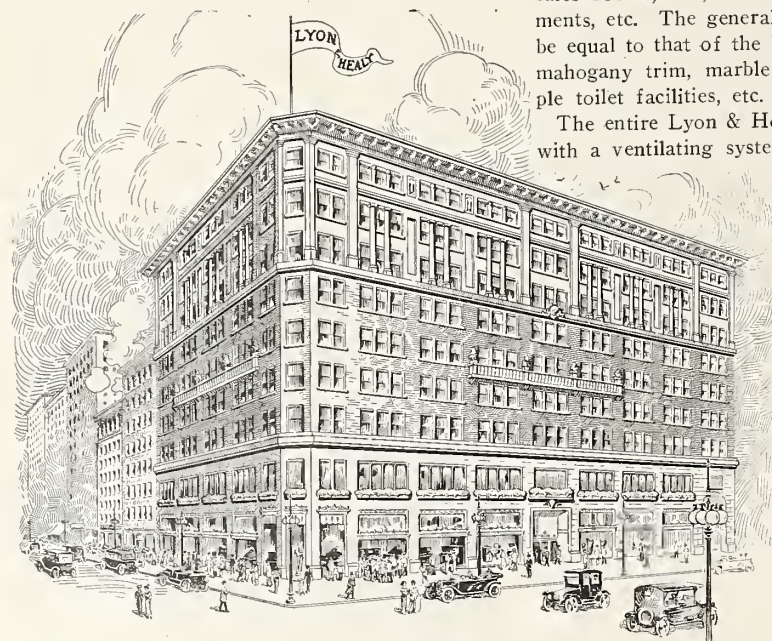

View of Lyon & Healy's New Home.

and basement, entirely of fireproof construction. The building is designed primarily for the needs of Lyon & Healy, but also will accommodate a certain number of offices on the upper floors. The present division of space being six floors for Lyon & Healy use and the three upper floors being subdivided into offices.

The office building entrance will be located on the east end of the Jackson boulevard frontage and leads into a spacious elevator lobby with ample elevator service for the office building section. The entrance to the Lyon & Healy store will be through this entrance; also a large entrance on Jackson boulevard and an entrance in the center on Wabash avenue.

The two lower floors of the elevations will be in pink Medford granite, the belt courses above in terra cotta granite to match. The upper floors will be of light gray brick with terra cotta cornices, belt courses, trim, etc., of a shade to match the granite. Large window spaces have been provided for all floors and the building will be very well lighted from natural sources. The general treatment of the exterior is of the Italian Renaissance period as to its main divisions and architectural details. The plain shaft of the facade is relieved by ornamental Italian balconies. The entire ground space, with the exception of the office building entrance, is occupied by Lyon & Healy, and will be of imposing aspect as one enters the store, due to the height of ceiling and the architectural treatment which will also carry out the Italian Renaissance



Display Window of the Wilson Avenue Talking Machine Co.

ARRANGING MOST ARTISTIC TALKING MACHINE PARLORS

Following Decision of Marshall Field & Co. to Handle the Cheney and Columbia Talking Machines, Plans Have Been Completed for Complete Transformation of Entire Northeast Corner of Third Floor of New Building in Chicago—Handsome Equipment.

(Special to The Talking Machine World.)

CHICAGO, ILL., October 10.—What will easily be one of the most magnificently equipped talking machine parlors and demonstration rooms will be opened in the new Wabash avenue building of

“Marshall Field & Co. in entering the talking machine field will, of course, concentrate their energies upon the Cheney machine, in which they are heavily interested,” said Mr. Howe. “We have contracted to take on the Columbia products, think-

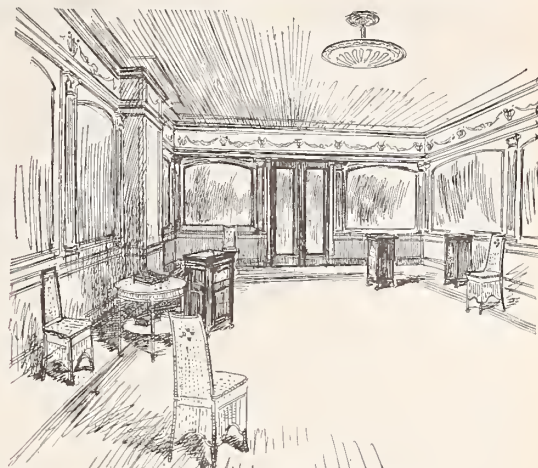

Another Talking Machine Parlor.

(Drawn by Vernon Howe Bailey.)

Aeolian Co., which recently completed arrangements for retailing the entire Columbia line—emphasizes the success of the Columbia Co.

NATIONS THAT BUY FROM US.

Canada Heads the List—Britain, Germany, and France Well Up.

(Special to The Talking Machine World.)

WASHINGTON, D. C., October 10.—What and how much the nations of the world are buying from the United States, as told by American Consular officers, are discussed in “Commercial Relations of the United States,” a volume of 272 pages, just issued by the Bureau for Foreign and Domestic Commerce. Four countries other than the United States offer each a market for over \$1,000,000,000 worth of foreign products annually—the United Kingdom, Germany, France, and the Netherlands. Great Britain buys \$3,000,000,000 worth, about 20 per cent. of which is from this country; Germany, \$2,500,000,000, with 15 per cent. from the United States; France, \$1,500,000,000, of which 11 per cent. is from the United, and the Netherlands, an important center for the transshipment of foreign goods, nearly \$1,500,000,000, in which American goods figure to the extent of about 10 per cent.



Marshall Field & Co.'s Talking Machine Display Room and Concert Hall.

(Drawn by Vernon Howe Bailey.)

Marshall Field & Co., this city, within six or seven weeks. Plans have now been completed by the architects for the complete transformation of the entire northeast corner of the third floor in the new building. Announcement to this effect was made to-day by E. L. Howe, of Marshall Field & Co., who has been greatly interested in this proposition of launching the new Cheney Talking Machine Co. and preparing for its retail home in Chicago's great store.

The plans of the architects called for a marvelously well equipped section. There will be a large concert room which will dominate the architectural arrangement. Prospective patrons and the public generally will here be given every facility for hearing the new machine.

In addition a large number of private demonstration rooms, built with every possible precaution to observe the principles of correct acoustics, will afford the means for personal and more private hearings of the Cheney machine.

The location of this great section is very well adapted to the convenience of the public, as it is next to the public rest room on the third floor, where it is estimated more than 100,000 people sometimes daily avail themselves of the courtesies and privileges extended by Marshall Field & Co.

Records will be sold in the new department, as well as the Cheney talking machine. Every effort will be made so that the assortment of records will be complete in every respect.

ing very highly especially of the Columbia records, and will carry a line of Grafonolas as well. This decision of Marshall Field & Co. to handle the Columbia line comes after a great many days of investigation, and we believe that the best results of the new Cheney machine are obtained with Columbia records.”

W. C. Fuhri, district manager of the Columbia

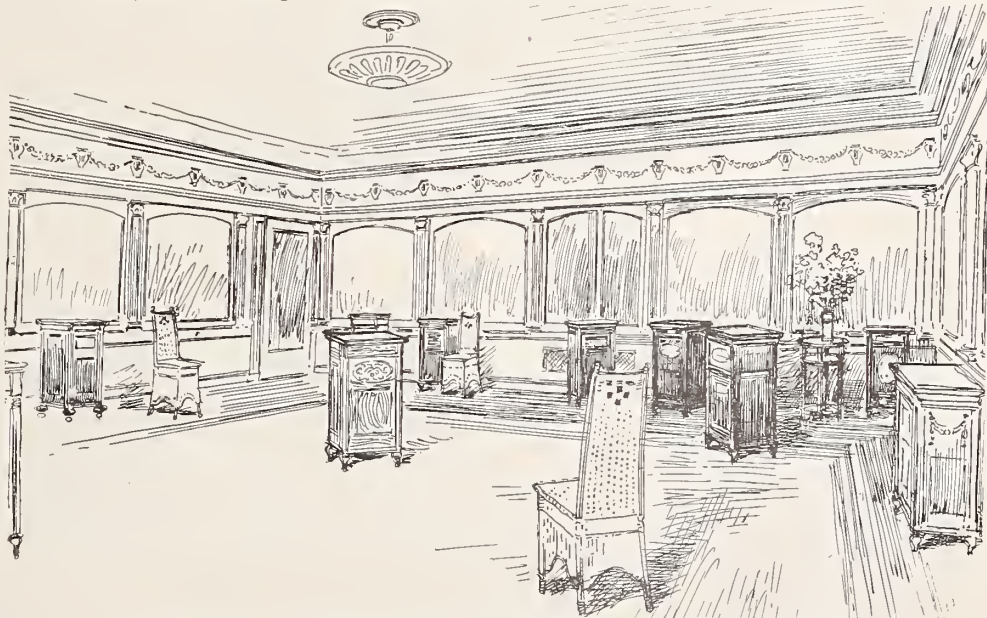

Another of the Marshall Field & Co.'s Parlors and Display Rooms.

(Drawn by Vernon Howe Bailey.)

Graphophone Co., discussing this important expansion of the Columbia interests, said: “Marshall Field & Co. have contracted with the Columbia Graphophone Co. to handle its line of Columbia Grafonolas and Columbia disc records. This highly important deal was consummated by Marshall Field & Co., after a most careful investigation of the Columbia line.

“The Columbia Co. is to be congratulated on the closing of the contract, as the house of Marshall Field & Co. is known throughout the world as standing for all that is best in department store equipment, management and quality. This announcement, coming so closely upon that announcing similar action by that other great house—the

Belgium's annual purchases fall just short of \$1,000,000,000 in value, United States products supplying about 8 per cent., while Austria-Hungary, Italy, Canada, Russia, India, Australia, Argentina, and Japan are next in order, with imports ranging from \$722,000,000 to about \$300,000,000. These countries vary greatly in the proportion of their purchases from the United States, Canada taking 65 per cent. and India 3 per cent. Brazil's imports exceed \$308,000,000 only 15 per cent. of which are from the United States, which takes 40 per cent. of the Brazilian exports.

The man who is on the winning side is most apt to preach the triumph of right.

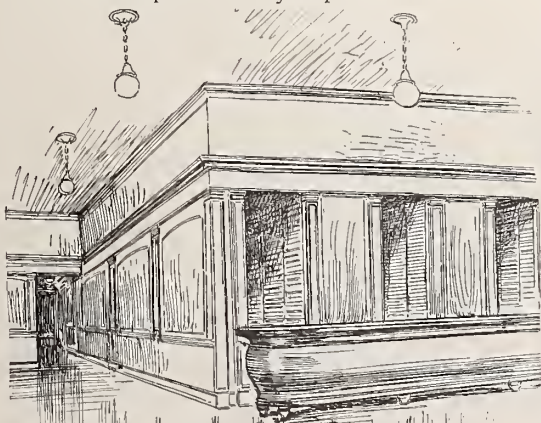

Plan of Counter and Music Rack.

(Drawn by Vernon Howe Bailey.)



Whether looked at from the viewpoint of art, reproduction, volume or tone, the new Columbia Grafonola "De Luxe"—\$200—is a winning article of merchandise.



(Write for "Music Money," a book "full of meat" for those dealers interested in quick and frequent turnover of capital.)

Columbia Graphophone Company
Woolworth Building, New York

POPULAR WITH UNIVERSITY BOYS.

T. E. Davis, of Ithaca, N. Y., Has Built Up a Large Business in That City—Features the Columbia and Edison Talking Machines.

(Special to The Talking Machine World.)

ITHACA, N. Y., October 6.—That the college trade in this city affords excellent opportunities for the live-wire talking machine dealer is well evidenced by the accompanying photograph showing the successful and attractively arranged estab-



T. E. Davis's Well Stocked Store in Ithaca, N. Y.

lishment of T. E. Davis, who handles both the Columbia and Edison cylinder lines.

Mr. Davis carries a comprehensive line of machines and records, and through his energetic and progressive sales methods has succeeded in building up a profitable and ever increasing clientele. His record sales in particular are growing day by day and this record demand includes not only the latest dance and popular music, but a good proportion of classic and operatic selections.

TALKERS FOR UTAH SCHOOLS.

Six More Machines Purchased by Ogden Board of Education to Assist in Kindergarten Work—Take Place of Teachers.

(Special to The Talking Machine World.)

OGDEN, UTAH, October 6.—Six more talking machines are to be purchased by the Ogden city board of education to be used in the kindergarten grades. The talking machine was first introduced in the local schools about a year ago, and has already demonstrated its value. The machines are used in teaching the children rhythm, both in singing and in dancing, and are said to greatly facilitate the work of the kindergarten grades. Superintendent J. M. Mills, in asking the board of education to purchase the new machines, stated that they would take the place of six assistant teachers.

The only people who can afford to sneer at luck are those who never expect to have any.

PEARSON OPENS NEW DEPARTMENT.

Prominent Indianapolis Piano House Provides Attractive Quarters for the Victor Line—Optimism Rules—Planning for Concert Season—Kipp-Link Co., Redecorating.

(Special to The Talking Machine World.)

INDIANAPOLIS, IND., October 8.—Optimism is the word which expresses the situation in the talking machine business here. And there is cause for optimism. Business is good. It is better than it was last fall. Therefore the talking machine dealers here are justly optimistic.

The opening of the Victor talking machine department of the Pearson Piano Co., 128-130 North Pennsylvania street, attracted not only the attention of the buying public, but also of the other talking machine dealers. Pearson's has a talking machine department which is not surpassed by any in the city. Displayed along with high-grade pianos, the Victor machines make an artistic addition to the company's windows.

The Aeolian Co., 237 North Pennsylvania street, has not yet obtained a complete stock of Columbia graphophones, but it is prepared to make sales of the new line of machines to be handled by this house. The company continues to handle the Victor line of talking machines.

The Stewart Talking Machine Co., 221 North Pennsylvania street, jobbers in Indiana for the Victor Co., is experiencing one of the best seasons in the history of the house. It has been necessary for the Stewart Co. to put another salesman on the road in Indiana. The traveling representatives of the house in Indiana are W. M. English and H. L. Prescott.

The Victor houses here are paving the way for the Ona B. Talbot-John McCormack concert to be given here October 29. McCormack records are very popular in Indianapolis, and the announcement that he will appear here soon in concert has increased the demands for his records.

The Kipp-Link Phonograph Co., 345 Massachusetts avenue, jobbers in the Central West for the Edison line of talking machines, is redecorating its display rooms in preparation for what the company expects will be the biggest year in its history. Demand for the Edison line among the Edison dealers of Indiana and neighboring States is enormous, according to Walter Kipp, president of the company. Mr. Kipp says the indications are that his house "will have to go some" to fill the orders. The Edison disc machine has made quite

a hit in Indiana. Comment on the superior tone of the new disc machine is often heard.

Surprise was caused here by the leaving of Thomas Devine for Kansas City, Mo., where he will be connected with the Columbia Graphophone Co.'s branch in that city. Mr. Devine was well known as local manager of the Columbia Co. He was in Indianapolis for approximately eight years. In his new position Mr. Devine will spend most of his time on the road covering the State of Oklahoma for the Columbia Co.

A. W. Roos, manager of the local Columbia branch, says the records show that business in September of this year was much better than it was in the same month of last year.

CLOSE TO THE BUSINESS HUB.

American Talking Machine Co., Brooklyn, Well Located for Convenient and Quick Service—General Business Outlook Excellent.

Quite in the center of things as to transportation are the headquarters of the American Talking Machine Co., the prominent Victor distributors, at 368 Livingston street, Brooklyn.

The name Brooklyn has a very off-sound to many dealers and others in the metropolitan district, but there are few concerns in the trade so well located with reference to the business centers of northern New Jersey, New York proper and Long Island as the American Co.

A minute from the door brings one to the Interborough Subway running direct to the heart of Manhattan and the Bronx. A quick change at Fulton street and one can take the Hudson tube to Jersey City, Hoboken or Newark, the whole trip taking less than one-half hour. One block from the store—Flatbush avenue and Fulton street—is one of the centers of an extensive elevated system of Brooklyn Borough, with many trains running directly over the bridges to Manhattan. Two minutes' walk in the opposite direction takes one to the Flatbush avenue terminal of the Long Island Railroad, with trains running direct to all points on Long Island and direct freight service, in connection with the Pennsylvania Railroad, to all parts of the country.

The wholesaling of talking machines, quick delivery on rush orders, is the most important feature, and at its present location the American Talking Machine Co. is in a position to render that service.

Under the direction of R. H. Morris, head of the company, the store has been remodeled recently to permit of increased stock and shipping facilities. The three demonstration booths have been moved to the front of the store, leaving the entire rear section free for use in handling orders. The new arrangement takes advantage of considerable space that was formerly wasted. Mr. Morris states that the outlook for fall and holiday trade is excellent. The stocks of Victor machines and records are in excellent shape, which means that an unusual percentage of orders may be filled. Dealers have shown an inclination to file their orders considerably in advance to insure sufficient stock when the expected rush comes, and at the present time there is apparently not a cloud on the business horizon.

FROM OUR EUROPEAN HEADQUARTERS

2 GRESHAM BUILDING, BASINGHALL STREET E. C., LONDON, W. LIONEL STURDY, MANAGER.

European War Affecting Trade Throughout World—Confidence Being Re-established in England—Volume of Trade Is Satisfactory Everything Considered—British Firms Reaping Rich Harvests of Sales in Colonies—Some "War" News—Supplies Rather Short—Patriotic Records the Vogue Just Now—Warships Discarding Pianos in Favor of Talking Machines—The News of the Month.

(Special to The Talking Machine World.)

LONDON, E. C., Eng., October 6.—With the efflux of time, it is perhaps not very surprising to find that the adverse influence of the great European struggle is affecting general trade the wide world over to a very appreciable extent. The sword has spiked the wheel of international commerce, and naturally has produced a certain amount of dislocation between even those countries not involved in this upheaval.

There are not wanting good signs, however, which tend to re-establish confidence, in that the overseas trade is now increasing and settling down to something like satisfactory proportions, all things considered. At least that is the view which prevails among business men on this side. Not that trade is really satisfactory compared with normal times, but the general relief at being able to do some business despite the war, is productive of great optimism which, perhaps, lends itself to slight exaggeration. Given the quick suppression of elements detrimental to shipping, i.e., the capture of the few enemy cruisers which are prowling around, the springs of commerce will immediately expand into new life. As it is, we are not doing so badly under the many adverse circumstances. (The foregoing remarks which concern trade generally do not exclude the gramophone industry.)

The export door of the whole Continental markets being "bolted and barred," British firms are reaping quite a rich harvest of sales in many of our daughter States. Our manufacturers are out for business, and they mean to take every advantage of the grand opportunity now presented to offset for all time the German claim to pre-dominance in the gramophone field of industry.

British Made Gramophone Goods.

As an instance of the awakening (ours admittedly has been a long sleep) of gramophone men to the possibilities of manufacturing gramophones in England, I would mention W. H. Reynolds, "the man of many parts," and known telegraphically under the pertinent synonym of "Knotaslepe," who has now made arrangements for the manufacture of motors, and other parts. This will be the first time that a commercial all-British motor has been built with any chance of competing with the Continental makes. There is no need to en-

large upon the evident difficulties which beset the path of development in this particular sphere of trade activity, but rather to pay tribute to the enterprise and enthusiasm with which the matter is being handled in so highly satisfactory a manner. It is no mean thing to establish at such short notice what may be regarded from our standpoint as a new industry, whose manufacturing interests have at least not been cultivated hitherto on this side of the channel. We can but assure Mr. Reynolds that his progress will be keenly watched by the whole trade, who we feel will not be slow to accord his efforts every legitimate support.

Gramophone Co., Ltd., Remove to Factory.

Having placed the whole of its City Road premises at the disposal of the military authorities, the Gramophone Co., Ltd., has now removed to the great factory at Hayes, Middlesex, where in future all communications must be addressed. The London sales department is located at 94 Regent street, W.

J. E. Hough's Generosity.

From the old Edison Bell firm I learn that J. E. Hough is offering all bachelor-members of the staff who join the army a bonus of two guineas, with re-employment after the war. Some fifteen "velvet faces" are now under arms.

Gramophones Replace Pianos.

Pianos, I learn, have been thrown overboard from many of our warships in the North Sea, but most have retained their gramophones; truly, the king of instruments! In this connection a recent appeal for old records brings to light another thoughtful action on the part of J. E. Hough. "Old" records for our sailors—No! And straightway this bluff trade veteran submits a plan for the supply of "new" records in 200 parcels of twenty-four each, and is willing to send 500 parcels if required. Further, when the records are worn out, thanks to Mr. Hough's practical and generous offer, the sailors may change them for new ones free of any charge. The British Admiralty accepted this offer out of a round dozen placed for its consideration.

That Famous Marching Song.

"It's a Long Way to Tipperary," the marching, if not the battle song of our troops, was first issued some two years ago. Messrs. Feldman, the publishers, inform me that the song was refused by practically every publisher in London. The sheet music sales are now said to be about 8,000 daily! Special editions are now ready for the Canadian and Australian markets.

Some War Items.

Capt. S. W. Dixon, an "H. M. V." director, who saw service in the South African war, has again been commissioned for the front, where doubtless he is now taking an active part in the fighting line.

Seventy per cent. of the Russian "H. M. V." staff are on active service, and the manager and staff of the Paris branch are with the French forces. Quite a number of the Hayes employes are with the British colors.

A splendid war program is announced by the Winner Record Co., the all-British gramophone house, who intimate that the whole profits on the sale of these special records will be handed to the Prince of Wales' National Fund. This generous plan insures a continuity of work for the Winner staff, while at the same time providing a substantial margin of monetary assistance for those in distress. Most excellent!

"Regal" patriotic records are in great demand. A small royalty on the sale of each one is allotted to the Prince of Wales' fund, which in consequence has benefited to the extent of 150 guineas already.

In a brief account concerning the naval fight in the Heligoland Bight, an A. B. describes the flight of German shells as "whistling just like a needle on a broken record." A good yarn, surely!

The mere fact of war does not destroy copyright conferred upon the works of an alien enemy in accordance with the provisions of the Berlin copyright convention of 1908, and the Austro-Hungarian copyright convention of 1893.—Mr. Runciman, in the House of Commons.

In a recent statement the Sound Recording Co., Ltd., makers of the Gramavox records, give publicity to the fact that these products are British made, financed, and controlled by Englishmen.

Statements have been made to me that certain people have stamped "Made in England" on goods of distinctly German origin. Is there any confirmation?

In furtherance of the war upon German and Austrian trade, the Commercial Intelligence Branch of the Board of Trade, Basinghall street, London, E. C., has issued a number of trade leaflets giving the export figures of these two countries. Leaflet No. 42 deals with musical instruments and parts thereof. It makes interesting reading matter and copies may be obtained upon application.

Supplies Are Getting Short.

Supplies are getting short on motors, tone-arms, sound boxes and trumpets. The Continental service is of no account, unless we place some reliance on the Swiss manufacturers, who, it is true, promise deliveries shortly. But—hurry up British manufacturers!

Annual Report of Gramophone Co.

According to a financial contemporary, the profits of the Gramophone Co., Ltd., for the fiscal year ended June 30 last are £138,186, an increase over the previous year of £37,332. Considering the

(Continued on page 52.)

"RENO,

THE MAN OF MANY PARTS"



The *only* man in the world who can supply you with *one* part—or *any number* of parts for *any* Talking machine ever made from Adam to Edison-Roosevelt.

64 Page Catalogue Yours for Asking

W. H. REYNOLDS, Ltd.
"KNOTASLEPE"
London, England



HOFFAY'S

"The World's Musical Instrument"

GRAMOPHONE

Ready to entertain propositions from distributors and manufacturers in thirty-one countries where patents have been applied for, and in most cases already accepted or granted.

Full illustrations of some of its "features" will appear in next issue.

J. HOFFAY

67 Egerton Gardens, South Kensington, London, England

FROM OUR LONDON HEADQUARTERS—(Continued from page 51).

general meeting Trebor Williams stated that immediately prior to the outbreak of the war their business was in a very satisfactory state. It had been felt advisable to make special provision to the amount of £42,380 against foreign debtors, that figure having been arrived at on a basis of percentages, varying according to the different countries concerned. The amount might turn out to be either largely under-estimated or largely over-estimated. When the war broke out the bulk of the company's business on the Continent came to an abrupt and complete standstill, and where their business did not cease altogether, it very much decreased. With regard to what was happening to their interests in Germany and Austria, they had but little information of value. As to other countries, arrangements were being made for carrying on the business, protecting the assets, and for ultimately resuming operations on normal lines. In some countries and in the colonies, for the time

being, business was fairly good. In great Britain there was a strong, and, we understood, an increasing demand for records, more particularly for those of the patriotic song description. As long as the existing state of affairs continued it would be impossible for the company to earn profits for dividend purposes, and the discontinuance of quarterly interim dividends followed as a matter of common prudence, if not of actual necessity.

J. Hoffay in New York.

Just prior to posting my monthly packet of news, I learn that J. Hoffay is planning a trip to New York, and expects to arrive about the middle of October. The chief object of his visit is to make arrangements for the manufacture and distribution of "The World's Musical Instrument," which by the way, I have at last been privileged to examine. Only the exigencies of time prevent me from expressing my views at the moment, but on a near future occasion I shall hope to furnish read-

ers with a full description of this new and pre-eminently fine musical instrument. For the present let it suffice to say that for really natural tone-pictures, commend me to Mr. Hoffay's gramophone in conjunction with records of all makes.

Call for Patriotic Records.

Very optimistic in regard to trade prospects, O. Ruhl, of the Beka Record Co., this city, imparts the pleasing information that notwithstanding the war, record sales, of the patriotic type especially, continue to maintain a good showing, and he thinks there is every prospect of their Hertford factory being kept working practically on full time during the next few months, at least.

Columbia News Items.

The Columbia Co. draws particular attention to the new model of its No. 14 hornless graphophone announced for this season. As there is certain to be a rush for a reliable low priced

(Continued on page 53.)

FAVORITE RECORDS made in ENGLAND

Favorite Talking Machines—Favorite Needles
Favorite Albums—Favorite Carrying Cases

FAVORITE RECORDS in all LANGUAGES

ARE THE CHEAPEST AND BEST

Buy Them and You Will Increase Your Profits Note Our Special Patriotic Records

Write Today for Illustrated Catalogue, Lists and Advertising Matter

THE UTILITY TRADING COMPANY, 21 Paper Street LONDON, E.C.

Cables: UTILITRACO, LONDON

model in view of war conditions, this 52s. 6d. line should be in heavy demand. It embodies many improvements over previous machines at this price.

Two members of the staff of the London headquarters of the Columbia Graphophone Co. have rejoined their old regiments for active service. A third Columbia man, Harry E. Parker, an Englishman in the New York office of the company, was so keen upon serving his country that he obtained leave of absence and is now at the front.

The Columbia Co. has just issued its 1914-1915 catalog of Columbia graphophones and gramophones. We notice that, in addition to several new models, many improvements have been effected in existing styles, all the horn types from No. 2 (£4 4s.) upward now being equipped with twelve-inch turntables as against ten-inch turntables of last season—a raising of value that will win general approval.

Wholesale Gramophone Depot.

A somewhat serious fire, which originated in the premises of an artificial flower maker at the rear, involved a large gramophone warehouse at 150 Old street, this city, in the possession of Dayton & Co. Considerable damage was caused by fire, smoke and water to the huge stocks of talking machine goods stored on the premises. Over 18,000 Clarion and 100,000 or more Edison cylinder records were rendered unsalable. Fortunately, the damage is fully covered by insurance.

To Start in Business for Himself.

After two years' service with Blum & Co., J. Lewis Young, B.Sc., etc., informs us of his intention to start business on his own account. As one of the talking machine trade pioneers in Europe, his unique experience, covering every phase of the business, should prove of great value in his new sphere of activity, for the success of which we beg to offer our hearty good wishes. Mr. Young tells us he is open to consider any proposition for either manufacturing or selling, or as consulting expert.

The Latest Patriotic Favorite Records.

The Utility Trading Co. is to be commended for

Merely A Statement of Fact

The British Colonies and dependencies import annually many thousands of pounds' worth of gramophone products, a large percentage of which emanated from Germany.

Now that this source of supply is cut off, who is going to fill the breach?

This question must give British houses food for profitable thought.

But the opportunity for action is not tomorrow or the day after, it is Now!

The trade routes are open and we venture to think will so remain.

You can get into touch with overseas buyers through the medium of this trade newspaper, which enjoys a wide sale throughout the world.

Particulars and advertising rates will be gladly supplied to all interested by our European representative.

W. LIONEL STURDY

2 Gresham Buildings

Basinghall St., London, E. C.

the prompt issue of another list of patriotic numbers, which class of record the great talking machine public still continue to absorb in ever-increasing quantities. According to the standard demand, these new "favorites" will exactly fill the bill, and doubtless prove as popular from a sales standpoint as those issued last month. A few typical examples worthy of mention are (736), "La Brabanconne," and "March of the Victors," pleasingly rendered by the Favorite Bijou Orchestra; (738), "Your King and Country Need You," the latest recruiting song, with which is coupled a fitting companion bearing the title, "I'd Like to Be a Hero, Too," both songs being delivered in fine style by Thomas Howell. "It's a Long Way to Tipperary," is told by that favorite vocalist, Harry Core, on record No. 740, the reverse bearing a spirited xylophone solo, "The Islander March," by our old friend, Billy Whitlock. On record 741 the Favorite Elite Orchestra presents an excellent descriptive tone-picture of "Our Expeditionary Force Landing in France," and this, coupled with the "Punjaub March" by the same

instrumental organization, goes to the making of what is an especially attractive record.

Suspension of British Patents Held by Enemy.

Apropos of the above, the following rules are now in force:

(a) A notice will be sent to the patentee's address for service and to any licensee before action for suspension of license be heard.

(b) Notice of application for suspension of license will be advertised in the Official Patents Journal.

(c) There will be a short opposition period, and a date for hearing will be advertised in the journal, and at such a hearing a representative of the patentee or licensee will be entitled to be heard against the grant of such suspension of license.

(d) Applications made by individuals in respect of the same patent will be heard, as far as possible, together, and it will depend upon circumstances whether the license will be exclusive or not.

(Continued on page 54.)

EDISON BELL-V F-VELVET FACE



JOHN BULL AT WAR

PATRIOTIC RECORDS

- | | | |
|------|---|---------------------------|
| 1409 | Landing of the British Army in France, Pt. 1 | Descriptive |
| | Landing of the British Army in France, Pt. 2 | " |
| 1410 | Tommy Atkins | Robert Howe |
| | The Lads in Navy Blue | " " |
| 1411 | Sons of the Sea | " " |
| | Soldiers of the King | " " |
| 1412 | Jack's the Boy | " " |
| | The Anchor's Weighed | Alan Turner |
| | La Marseillaise and The Red, White and Blue | Robert Howe |
| 1413 | Hearts of Oak, and God Save the King | " " |
| | Boys in Khaki, Boys in Blue | Stanley Kirkby |
| 1414 | Your King and Country Need You | " " |
| | Here's to the Day For King and Country | " " |
| 1415 | La Marseillaise, and The Russian National Anthem, London Regim'l Band | " " |
| 1416 | Rule Britannia, and God Save the King | London Regimental Band |
| | Regimental Marches of the Brigade of Guards (Slow) | " " |
| 1417 | Regimental Marches of the Brigade of Guards (Quick) | Band of H.M. Irish Guards |
| | British Empire March | Band of H.M. Irish Guards |
| 1418 | Steadfast and True, March | London Regimental Band |

12-in. Discs Double Records 4/-

- | | | |
|-----|---|---------------------------|
| 640 | Inflammatu ("Stabat Mater") | Band of H.M. Irish Guards |
| | Cujus Animam ("Stabat Mater") | Band of H.M. Irish Guards |
| 641 | March of the Knights of the Holy Grail ("Parsifal") | Band of H.M. Irish Guards |
| | Overture "Rosamunde" | Band of H.M. Irish Guards |
| 642 | O Rest in the Lord | Miss Jessie Broughton |
| | O Divine Redeemer | " " |

10-in. Double Side 2/6 each

- | | | |
|------|---|---------------------------|
| 1403 | Your Heart will Call Me Home | Charles Compton |
| | Since Last We Met | " " |
| 1404 | The Girl I Mean to Make My Wife | (March Intermezzo) |
| | Mam'selle Tra-la-la (Waltz) | Royal Court Orchestra |
| 1405 | Temple Bells ("Indian Love Lyrics") | Royal Court Orchestra |
| | Less Than the Dust ("Indian Love Lyrics") | Miss Mabel Mann |
| 1406 | In an Old-Fashioned Town | Miss Mabel Mann |
| | Three Fishers | " " |
| 1407 | St. David (Welsh Patrol) | Band of H.M. Irish Guards |
| | Wearing of the Green (Quick March) | Band of H.M. Irish Guards |
| 1408 | Clever Mr. Green (Patter Song) | Harry Bluff |
| | The Waiter (Patter Song) | " " |

IF YOU ARE INTERESTED SEND FOR FULL CATALOGUES TO

EDISON BELL WORKS, Glengall Road, London, S.E.

J. E. HOUGH, Ltd., Proprietors

BEKA DOUBLE-SIDED RECORDS

BRITISH MADE THROUGHOUT

Our Latest Supplement Contains all the
PATRIOTIC AIRS and NATIONAL ANTHEMS

Catalogues and terms on application.

O. RUHL, Ltd., 77 CITY ROAD, LONDON, ENGLAND

FROM OUR LONDON HEADQUARTERS—(Continued from page 53).

New Company Incorporated.

Autovox, Ltd., private company, capital £4,500, manufacturers of gramophones, records, musical instruments, etc. The address of one of the directors, C. Vane, is given as 166 Piccadilly, London, W.

Loyal Edison Bell Velvet Faces.

Of the many so-called war lists, that announced by J. E. Hough, Ltd., makers of the renowned Edison Bell "Velvet Face" records, occupies a very prominent position in the estimation of all good Britishers, and with good reason, too. "V. F.s" are of home manufacture throughout, financed and controlled by Englishmen, at the head of whom we have J. E. Hough, as typical a specimen of the John Bull type as one could desire. But that in passing. Of unusual interest is the company's stirring patriotic repertoire of vocal and instrumental music, covering every shade and type of selection, both old and new. The British, French, Russian and Belgian national anthems bulk largely in the most recent list, on which, too, is itemized such popular airs as "Tommy Atkins," "The Lads in Navy Blue," "Sons of the Sea," "Soldiers of the King," "Jack's the Boy," "The Anchor's Weighed," "Here's to the Day," etc. "Boys in Khaki, Boys in Blue," in companionship with the specially composed recruiting song, "Your King and Country Need You," on No. 1414, should be heavily ordered, since if the demand in England is any criterion, and we believe it is, this record is sure to be popular in all British dependencies. Among descriptive records No. 1409 offers a striking presentation of the "Landing of the British Army in France," in two parts, and we should advise our Colonial readers to cable for

COLONIAL and FOREIGN BUYERS

of gramophones and records may obtain valuable information from English firms who are desirous of opening up trading relations with oversea markets upon application, stating requirements, etc., to our European representative,

W. LIONEL STURDY

2 Gresham Buildings,

Basinghall St.,

London, E. C.

immediate supplies. Some further examples of "V. F." program will be found in their announcement elsewhere in this section.

TOURING ENGLAND'S HIGHWAYS.

John Cromelin, General Manager of the European Interests of the Columbia Graphophone Co., a Motor Enthusiast—Entertained M. D. Easton and Wife During Their Recent Honeymoon Trip Abroad.

John Cromelin, general manager of the European interests of the Columbia Graphophone Co. and one of the best informed men in the industry, is a keen motor enthusiast and frequently takes extended tours through the beautiful highways of Great Britain in his high speed touring car. Mr. Cromelin, who is an adept at the wheel, runs his car with the same unerring judgment that characterizes his handling of momentous executive matters.



John Cromelin Entertaining Mr. and Mrs. Easton While in England.

TO DRUM UP TRADE FOR U. S.

Commercial Attaches Named by Secretary of Commerce Redfield.

(Special to The Talking Machine World.)

WASHINGTON, D. C., October 7.—The Department of Commerce has announced the personnel of the corps of commercial attaches provided for by Congress to help drum up business for the United States and to keep our commercial interests in touch with all parts of the world.

These are the attaches selected by Secretary Redfield: A. J. Harrington, of Ohio, for Lima, Peru; A. H. Baldwin, ex-chief of the Bureau of Foreign and Domestic Commerce, for London; Dr. Albert Hale, of the Pan-American Union, for Argentina; Edwin W. Thompson, of North Carolina, for Berlin; J. H. Arnold, at present consul-general at Hankow, for China; Prof. Lincoln Hutchinson, of the University of California, for Rio de Janeiro; C. W. Veditz, of Pennsylvania, for Paris.

SOMEWHAT SARCASTIC.

Some of us are so accustomed to looking out for number one that we get positively nearsighted.

The accompanying picture showing Mr. and Mrs. Cromelin in their motor car was snapped at Folkestone, England, by Mortimer D. Easton, manager of Dictaphone advertising, on the occasion of his recent honeymoon trip abroad. Mrs. Easton is seen standing by the side of the automobile, while Mr. Easton is, of course, invisible. Mr. and Mrs. Easton enjoyed a delightful trip by automobile while the guests of Mr. and Mrs. Cromelin.

WANTS MOTOR AND DIAPHRAGMS.

A merchant in Spain has notified an American consular officer that he is desirous of establishing relations with an American house manufacturing small motors, diaphragms and other accessories of talking machines. Catalogs and price lists of the goods in question are earnestly solicited. Correspondence should be in Spanish, and firms interested in this inquiry should address the Bureau of Foreign Trade Opportunities, Department of Commerce, Washington, D. C., referring to No. 13,801.

Edward A. Borgum is now the southern California representative of the Pacific Phonograph Co., of San Francisco, his headquarters being in Los Angeles.

STROH VIOLS

VIOLIN, VIOLA, ETC.

The mellow and matured tone of these instruments, which are constructed largely of aluminum, yet possess none of the characteristics of the gramophone or wind instrument, is only one of its many points which are fully set out in an illustrated booklet which will be mailed free on request to the sole makers.

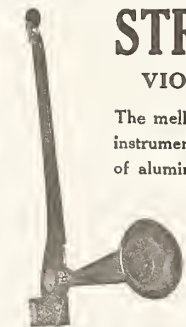

String Fiddle

GEO. EVANS & CO. 94 Albany St. London, Eng.

OR

in U. S. A. to their sole representatives

OLIVER DITSON CO.

150 Tremont Street BOSTON

NEW YORK and PHILADELPHIA



Violin



The highest priced talking machine on the market is a Columbia. The best low priced talking machine on the market is a Columbia. The best discounts all the way through are Columbia.



(Write for "Music Money," a book "full of meat" for those dealers interested in quick and frequent turnover of capital.)

**Columbia Graphophone Company
Woolworth Building, New York**

FALL IN WISCONSIN OPENS WITH A RUSH.

The Smaller Cities and Towns Show Great Activity—Milwaukee Not Quite as Satisfactory—Victrola Display at Pure Food Show—Becker's Plan of Pushing Sales—Talking Machines for Downer College—Kunde's New Quarters Ready—News of Month.

(Special to The Talking Machine World.)

MILWAUKEE, WIS., October 10.—The fall talking machine trade in Milwaukee and about Wisconsin has opened with a rush, considerably earlier than in former years. Conditions about the State have been showing considerable improvement and dealers seem to have been imbued with more confidence. Stocks in the hands of the average dealer have been light during the past few months and most retailers have come to the realization that now is the time to place their orders if they want to insure their prompt fulfilment. Jobbers say that dealers are placing good orders for both machines and records and that the outlook is bright for a continuance of this activity.

Conditions in Milwaukee, especially in the retail field, are hardly as satisfactory as in the smaller cities and towns about Wisconsin. This seems to be due to the fact that business with the heavy producing machinery concerns is still a little quiet, with many of these plants operating only part time. The result is that people in Milwaukee are not buying as freely as they might. This condition is regarded as only temporary, however, and better things are anticipated. As it is, the demand for high-priced machines seems to be holding up well, although the more moderate priced machines, such as the average working man might purchase, are moving slowly. In the country, however, the situation is different. Unusually fine crops have been harvested and are now being sold at high prices, with the result that there is more prosperity evident.

Milwaukee dealers say that collections have been a little quiet of late, but this is not to be wondered at in view of the depression which has existed in some lines of business. Jobbers say that they are finding little trouble with collections, showing that money is easier outside of Milwaukee.

The Victrola was well advertised at the annual Pure Food Show, held in the Milwaukee Auditorium, September 27 to October 3, as the result of an interesting exhibit maintained by the J. B. Bradford Piano Co., Milwaukee's oldest piano

house. The Bradford concern had two large adjoining booths at the show, filled with representative instruments carried, including an Auxetophone and a large type Victrola. Hugh W. Randall, manager of the Bradford player department, reports that the house secured a large number of live prospects. Between 10,000 and 15,000 people attended the show each day, and none of them failed to see the Bradford exhibit.

A sale of considerable interest was made recently by Paul A. Seeger, manager of the Victrola department at the Edmund Gram Piano House, when he disposed of a Style XI Victrola to Milwaukee Downer College, a well-known educational institution, for installation in the college seminary. The college uses a Victor for class demonstration purposes, and this machine has given such satisfaction that only the Victrola was considered for the seminary. Business at the Gram house has been showing considerable improvement of late.

John H. Becker, manager of the Victrola department of the Hoefler Piano Manufacturing Co., 306-308 West Water street, has evolved a plan for pushing the sale of records that every talking machine man might do well to follow. Mr. Becker's scheme consists of a one-page circular, printed in red ink, giving the number and title of some of the best Victor records issued this year, classified according to months. Naturally, more space was devoted to the October list. Mr. Becker says that this circular more than paid for itself the first day that it got into the hands of Victor owners. Mr. Becker intends to follow this plan each month from now on. Mr. Becker's wife, who has been very ill during the past two months, is again showing some improvement, and it is expected that she will soon be able to return from the hospital to her home. Mrs. Becker submitted to a second operation about three weeks ago.

Harry Fitzpatrick, traveling representative of the Victor Talking Machine Co. in this territory; D. C. Preston and Roy J. Keith, of the Talking Machine Co. of Chicago; H. P. Gibbs, of the Rudolph Wurlitzer Co., and Mr. Mahler, of Lyon & Healy, of Chicago, recently called upon the Milwaukee trade. All these representatives report that the fall business has opened up unusually well.

A steadily increasing demand for the Edison disc machines is reported by William A. Schmidt, general manager of the Phonograph Co., of Milwaukee, jobber in Wisconsin and upper Michigan for the Edison line. Several new dealers to handle the Edison disc goods have been secured during the past month. William Idle, traveler for the Thomas A. Edison, Inc., has been finding conditions about Wisconsin very favorable.

The new Badger Talking Machine Co., of Milwaukee, jobber in this territory for the Victor line,

has extended its field of operations and has appointed Morely Somers, an experienced talking machine man, as Northwestern representative. Mr. Somers will make his headquarters in Minneapolis and St. Paul, and will pay particular attention to the trade in those cities. Harry A. Goldsmith, secretary of the Badger Co., reports that the Victor business is opening up exceptionally well and that his house has secured several new dealers during the past month.

A. G. Kunde, Columbia jobber and dealer, expects to be ready to open in his new and attractive store in the new building now being erected at Grand avenue and Fifth street by October 15. Some little delay has been experienced in completing the interior work in the building. Mr. Kunde will have eight demonstration parlors on the first floor and four in the basement, and expects to have one of the finest retail talking machine establishments in Milwaukee. Mr. Kunde will have his former address, 516 Grand avenue.

Victor sales at Gimbel Bros.' store have been climbing to a high mark for the month of October. L. C. Parker, manager of the Victor and piano departments, looks for business to be good for the remainder of the year.

The Gensch-Smith Co., 730 Grand avenue, has been finding the Victor business so good of late that it has been thinking seriously of securing additional quarters.

EDWARD D. EASTON'S VIEWS.

In connection with a series of interesting business articles appearing in recent issues of *Printers' Ink*, Edward D. Easton, president of the Columbia Graphophone Co., wrote that publication as follows:

"I am very much interested in the article in your issue of September 10 under the heading 'How Advertisers Are Meeting the Present Situation.'

"This is an easy time to lose sales. All you have to do is to float down the stream with the calamity shouters, agree that it is impossible to get business, and let things drift.

"It is the policy of our company at such a time to increase our advertising appropriation substantially and put on more pressure in every department of the selling organization.

"We are working out a program which we are sure will give us, instead of a falling off, greater sales and greater interest in graphophones and records than ever before.

EDWARD D. EASTON."

I. DAVEGA, Jr.

125 WEST 125th STREET, NEW YORK

Victor Distributor

PROMPT AND ACCURATE SERVICE

DEALERS: Write for our Victor Pennant. Sent with our compliments.

NAME PLATES
DECALCOMANIE

Why not apply a transfer nameplate on your talking machine cabinets?

WRITE FOR SAMPLES AND PRICES. SKETCHES FREE

GEO. A. SMITH & CO. INC.
74 CORTLANDT ST., N. Y.

ROWE the B. WATER
Walschner Music Co.
WINNIPEG PIANO CO.
ROSE E. DRURY
Mack

ENTERPRISING VICTOR DEALERS.

Epstein & Berdy, with Stores in New York and Brooklyn, Install New Equipment to Take Care of Growing Demands.

Epstein & Berdy, who conduct talking machine stores at 2977 Third avenue, New York City, and 1198 Fulton street, Brooklyn, are to be included among the progressive and promising retail repre-



Epstein & Berdy's Attractive Quarters.

sentatives of the Victor line in Greater New York.

By hard work, perseverance and mastery of the many details of store management, these gentlemen have built up a profitable business for both stores, and as proof of the manner in which they have won the confidence of their customers in Brooklyn, especially, it was necessary recently for them to install two additional demonstrating booths in their Fulton street store. There are now five booths in the store and they are all needed to take care of the demands.

Since taking over the business about a year ago, the firm has spent a tidy sum in rearranging the show windows, installing new booths and interior decorative work, but according to Mr. Epstein, the expense was more than covered by the profits from last winter's business.

THE PHONOGRAPH AS AN EDUCATOR.

The influence of the talking machine as a musical educator was demonstrated recently in Mari-

nette, Wis., when an Edison disc phonograph which was presented to the Public Library of that town by a wealthy citizen was utilized for the purpose of entertaining pupils in the public schools. Daily recitals were given. The librarian, Miss McCarthy, recently entertained the pupils of the fifth grade of the local schools, and asked them to express their appreciation in writing, with the result that there were some very novel and interesting essays on the merits of the Edison disc phonograph, and effusive admiration

expressed for Thomas A. Edison, its inventor. Everyone seemed to be impressed not merely with the delightful music they heard, but the history of each record was explained to them by the librarian so fully that it made a lasting impression on their minds.

INCORPORATED.

The Tri-State Talking Machine Co., El Paso, Tex., has been incorporated by J. M. Spain, W. C. Walz and H. T. Walz.

RECEIVE THE GRAND PRIZE.

Tenshodo, Who Handles the Columbia Line in Tokyo, Awarded High Honors at the Tokyo Taisho Exposition—His Courteous Announcement of the Receipt of the Award.

The Columbia Graphophone Co. received last week a communication from Tenshodo, its dealer in Tokyo, Japan, wherein this successful merchant calls attention to several important honors he received at the Tokyo Taisho Exhibition, an annual event which is looked forward to with keen interest by merchants in Japan. It is indicative of the popularity of the Columbia products in the land of Nippon that Tenshodo was awarded the Grand Prix, an unheard of honor heretofore.

Written in the courteous phraseology of the Orient, this letter reads:

"We take this opportunity to announce you of honors we received at the Tokyo Taisho Exposition, which has just been closed. When T. I. M. the Emperor and Empress visited the exhibition, their Majesties were pleased to purchase some of our exhibits. We deem this the unique honor conferred on us. It is our greatest pleasure to inform you in this connection that we have been awarded the Grand Prix at the exhibition—such honor as never given to any of our fellow exhibitors. These have undoubtedly promoted our credit and reputation, which we attribute to your favors in the past. Begging you will continue to honor us with your patronage, We remain, Ever truly yours,
(Signed) "TENSHODO."

ELECTED VICE-PRESIDENT.

E. E. Robinson, formerly connected with the export department of the Columbia Graphophone Co. as a traveler, has been elected vice-president and general manager of the Grafonola Co., Rochester, N. Y., a prominent dealer in Columbia products with a large and growing business. Mr. Robinson, who has made extensive travels through South America, the Orient and to Cuba in the interests of the Columbia Co., is certainly well qualified to achieve success in his new position.

The Herzog Magazine

carries a beautiful cover this month, similar to the print shown here, and makes its readers acquainted with the "best in current musical matters" by interesting articles and exquisite illustrations. The Talking Machine trade will profit greatly by becoming better acquainted with this excellent magazine published by

The Herzog Art Furniture Co.
Saginaw, Mich.

**Herzog Art Furniture**

is known to many owners and advertisers of good talking machine equipment. Herzog Record Cabinets are being made more and more popular every day by the increasing circulation of THE HERZOG MAGAZINE and by the satisfaction of its many owners. You will profit by becoming better acquainted with the product of

The Herzog Art Furniture Co.
Saginaw, Mich.

BENJ. SWITKY NOW WHOLESALING EXCLUSIVELY.

Well-known Victor Distributer, in Interview, Explains the Reasons for His New Business Departure—Reviews Some Trade Conditions—Occupies Commodious New Quarters in Carlisle Building, 19-25 East 24th Street, New York—Enjoys Modern Equipment.

Some months ago Benj. Switky, the well-known Victor distributor, announced at a meeting of the talking machine dealers that he planned to give up his retail business and devote himself to jobbing exclusively, so that he would not compete with the dealers in their own field. Last month Mr. Switky advertised for sale, and disposed of, his retail business, and secured new wholesale quarters in the Carlisle Building, 19-25 East Twenty-fourth street, New York. In this issue of The Talking Machine World, Mr. Switky makes the formal announcement of his new move.

In commenting upon his new and radical movement, in an interview with a representative of The World, Mr. Switky offered some interesting views bearing on the talking machine business, both past and present, and said, in reference to his retirement from the retail field:

"In my opinion, the time is coming when the dealer will discriminate against the jobber who does a retail business and, I believe, rightly so.

"The jobber who caters to retail trade comes into direct competition with many of his own dealers. He finds himself in an embarrassing and illogical position. He is constantly being accused of bad faith by the dealer, no matter how conscientious the jobber may be, and no matter how strong his profession of loyalty.

"Years ago, when the first types of talking machines were manufactured, it was a serious problem how to market the output. One manufacturer sold his wares through canvassers sent out from a central office. Another manufacturer gave certain territorial rights to individuals or firms, based on the size of the initial order or an agreement to purchase a certain number of machines within a given time. Still another manufacturer would market his product through department stores and individuals—dividing them into two classes, known as jobbers and dealers. Dealers in turn were subdivided into two classes, with different discounts, based on the size of their initial order.

"In the early days it was not necessary for a jobber to job. It was his privilege to refuse to sell to the trade. The jobbing discount was given in consideration of the size of his initial order.

"Later it became necessary for the jobber to purchase a minimum amount annually in order to retain the jobbers' discount. It was then that certain so-called jobbers began to look around for wholesale business. Thus it will be seen that originally the retail end of a jobber's business appealed to him most.

"When a progressive dealer found his purchases running quite high, it was natural for him to try to get jobbers' prices so as to increase the profit on his retail business. This accounts for the existence of many big retailers who, while enjoying jobbers' discounts, make no pretence to pose as

distributers in the proper sense of the word.

"But with the wonderful growth of the talking machine business, together with the determination of the manufacturers to limit the number of distributers, many of us found the wholesale business growing faster than the retail.

"In my opinion, the jobber must now choose between the wholesale and the retail. He cannot have both. The dealer is no longer satisfied to take the jobber's overflow stock, nor is he satisfied to share with the jobber; in fact, he feels that the jobber should place all his stock at the dealer's disposal. During the past two or three years, when machines and records have been short at times, the dealer has felt that the jobber had no right to make a retail sale until after he had supplied all the needs of his dealers.

"The dealer often looks with suspicion and disapproval upon the distributer who increases the number of his sound-proof rooms so as to cater to increased retail trade. It is hard to make him believe that the jobber's beautiful and expensive retail department will be sacrificed during the holiday shortage. The jobber may make the sacrifice, but the dealer will not believe him.

"The dealer has a right to insist on clean goods that have not been handled by the retail department of the jobber.

"The dealer has a right to insist that the jobber shall not use his extra discount nor his standing as a wholesaler unfairly to compete with him in advertising for retail business.

"The dealer has a right to insist that the jobber shall not compete with him in the instalment business, because the difference in discount makes the competition unequal.

"I am happy to be able to-day to fulfil the promise made to the Eastern Dealers' Association some time ago—that I would give up the retail just as soon as I could rearrange my affairs.

"I have given up a profitable retail business, one that represents eleven years of untiring effort. I have sacrificed retail profit for wholesale principle, confident that my course will meet with the approval and support of every dealer."

Mr. Switky's new quarters in the Carlisle Building are commodious, convenient and attractive and take up the entire fourth floor of the building with 7,500 square feet of floor space. The arrangement and equipment is most modern in every respect, with an abundance of light on all sides, three passenger and two freight elevators, and even shower baths on the roof and running ice-water on all floors for the convenience of the tenants. With such facilities on a hot summer day, Coney, the seashore, loses its charm. Strictly fireproof construction and an elaborate sprinkler system protects against loss by fire and the consequent delays that follow and also provides



NYOIL

For polishing
varnished woodwork it is
extremely satisfactory. No oil is so clean.

Ask your watch repairer whose
oil he uses on your watch.

for about the lowest insurance rate in the city.

The floor is divided into two sections. The front half is given over to a completely equipped repair shop, under the competent management of A. H. Dodin, and to the stock of machines, while the rear section is divided into a record storage room, with the alleys enjoying natural light, packing and the shipping department, Mr. Switky's private office and the general offices and a large and handsomely furnished display room, where the dealers can come to select stock and also bring their customers. The display room is shut off so that the dealer and his customer may enjoy strict privacy while testing and selecting the desired machines or records. It is Mr. Switky's plan, also, to hold occasional classes in machine repairing for the dealers and their salesmen, where the retailers may learn how to make minor repairs and adjustments at times when it is not convenient to send the machines to a repair shop. In other words, in the new quarters service will be a fact rather than a promise.

The work of moving the stock took place during the week ended October 3 and on the morning of October 5 the new Switky quarters were settled and ready for business.

JOHN A. ALSEN ILL.

Members of the talking machine trade will be sorry to learn of the serious illness of John A. Alsen, head of the talking machine department at George Lincoln Parker's piano warerooms in the Colonial building, Boston. Mr. Alsen is threatened with typhoid fever.

No two things in the world seem further apart than the artistic temperament and a bank account.

HERMANN THORENS, Ste. Croix (Switzerland) TALKING MACHINE WORKS

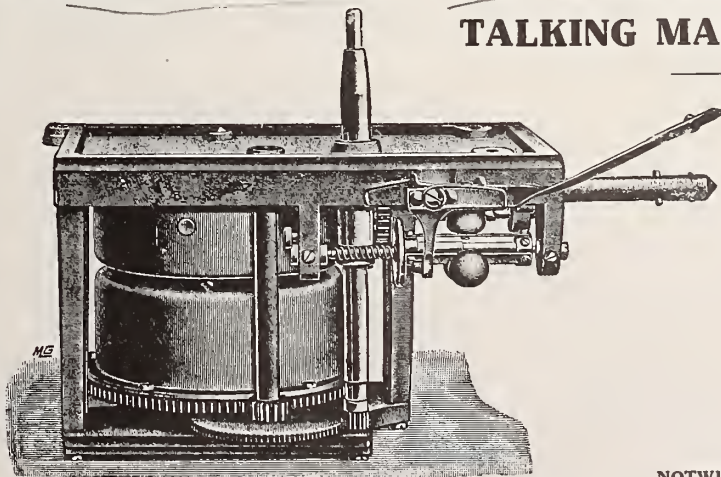

Motors and Sound Boxes a Specialty

CONCEDED TO BE THE BEST MANUFACTURED
OVER THIRTY DIFFERENT STYLES

FIRST QUALITY ONLY

HIGHEST RECOMMENDATIONS

WRITE FOR DESCRIPTIVE CATALOGUE

NOTWITHSTANDING THE EUROPEAN WAR, WE ARE ABLE TO SUPPLY YOUR WANTS



The first sale of a Columbia record is the beginning of a steady business—business you should get and can get.



(Write for "Music Money," a book "full of meat" for those dealers interested in quick and frequent turnover of capital.)

Columbia Graphophone Company
Woolworth Building, New York

OPTIMISM HOLDS SWAY IN CINCINNATI TRADE.

New and Larger Quarters for the Phonograph Co.—Aeolian Co. Adds Columbia Line—J. Shillito to Handle Talkers—The Wurlitzer Co. and the Aeolian Co. Make Encouraging Trade Reports—Cable Company's New Victor Department Opened—Late News.

(Special to The Talking Machine World.)

CINCINNATI, O., October 8.—The local branch of the Phonograph Co., of Cleveland, which looks after much of the territory in this section of the country, is going to take quarters in the sixth floor of the Globe-Wernicke building, on East Fourth street. This is directly opposite the Rudolph Wurlitzer Co. The move, which has not yet been publicly announced, will be made between now and November 1. It is no secret that the change will be hailed with delight by the dealers of Edison machines in Cincinnati for the distributor has been making cash sales and expects to continue to do so, but the new location will not be as prominent as of old. The branch was opened last fall and under the direction of A. C. Peterson numerous agencies have been established in the Ohio valley.

One of the big surprises of the past month and the season for that matter, was the announcement that the Aeolian Co. would handle the complete Columbia line as well as the Victor. The first impression was that the local house would dispose of the Victor line, but such is not the case. The Cincinnati branch, not being a distributor, can handle both lines. The Columbia Graphophone Co.'s September report to headquarters received a most handsome boost through the Aeolian order.

Considerable interest prevails as to which line will be handled by the new music department of the John Shillito Co. The first impression was that the Columbia had the inside track. The status somewhat remains unchanged. The booths have been ordered. Edwin Holt, of the Aeolian Co. resigned this week to become the assistant manager of the new Shillito department.

The Grafonola Co., of Cleveland, last week was authorized by the Secretary of State to increase its capitalization from \$15,000 to \$25,000.

Manager Stotler, of the Milner Musical Co., has returned from a fishing trip in Wisconsin. The journey was noted for the number of rainy days.

Manager Dittich, of the talking machine department of the Rudolph Wurlitzer Co., gives the following summary of local conditions:

"The month of September continued the good record of August, and in consideration of conditions prevailing, the result showed very good indeed. While the wholesale conditions do not seem to be uniformly good, still there are enough dealers who are doing an exceptionally large business to bring up the volume of trade to the required amount, to make a most satisfactory volume. The Victrola is constantly increasing in popularity and the establishment of new agencies has

apparently aided very materially, in increasing both the volume of the sales and the prestige of the article. Our files show a constantly increasing number of record buyers, and that part of the business alone without taking into consideration the machine end of the business, had very flattering prospects.

Manager Whelen, of the local Columbia store, when asked about conditions of the present day, said: "Well, we did not have as good a retail month as we would like to have had, but we more than held our own. Wholesale business, however, was on the boom, and we closed up with one of the largest months we have had this year. This goes to show that the dealers are preparing for a large fall and winter business, and they are getting ready to meet the demand. In this line of progress the Aeolian Co., one of the oldest piano houses in the country will carry a complete line of Columbia machines and records in all its stores, including Cincinnati and Dayton. We are optimistic about the talking machine business, despite the war, and when the year is closed up we expect to far exceed last year."

W. S. Givler, traveling man for the local Columbia store, has just come in from a successful trip through the territory, and reports conditions good. He turned in a large number of orders for immediate shipment and a "big bunch" for future delivery.

The Cable Company's new Victor department, which was opened on Saturday, has met with considerable success. Wholesale Manager Sumney is well pleased with this new avenue of business.

Special

Send for a package of our Improved Half-Tone and Loud Tone Needles in New Style Envelopes.

If you want to advertise yourself, we will put your own name or trade-mark on the envelopes, or will pack in Puritone envelopes.

Quality Guaranteed

The Best Needles mean profit and satisfaction.

If you want to sell 1,000 Needles at a time instead of 100, use the "Dean-packed" Needles. Five boxes of 200 each, Extra Loud, Loud, Opera, Medium and Soft packed in a carton. The best package and fastest seller on the market. Write for samples.

JOHN M. DEAN, CORP.

Talking Machine Needle Manufacturers

PUTNAM, CONN.

TALKING MACHINE EXPORTS.

The Figures for July and August Presented—Exports Show Increase for the Months.

(Special to The Talking Machine World.)

WASHINGTON, D. C., October 10.—In the summary of the exports and imports of the commerce of the United States for the months of July and August (the latest period for which it has been compiled), which has just been issued by the Bureau of Statistics of the Department of Commerce and Labor, the following interesting figures relating to talking machines and supplies are set forth:

The total exports of talking machines for July and August, 1914, amounted in value to \$180,878, while records and supplies for July and August, 1914, amounted in value to \$150,973.

SALE OF POOLEY CO. PROPERTY.

(Special to The Talking Machine World.)

PHILADELPHIA, PA., October 10.—The receiver for the Pooley Furniture Co., M. Weinman, announced that he will offer all the property of the company at public sale on the premises at Seventeenth street and Indiana avenue on October 14. The sale has been ordered by the court and the amount realized will be distributed among the creditors.

Many a man is so exclusive that he isn't even on speaking terms with his conscience.

COLUMBIA CO. TO RECORD SAN FRANCISCO PRIZE SONG.

"1915—San Francisco" to Be Strongly Featured in Columbia Records and by Other Means—W. S. Gray Takes a Lively Interest in the Work of the Contest Judges—Asks Public to Indicate Favorite Artists for Recording—2,000 Manuscripts Considered.

(Special to The Talking Machine World.)

SAN FRANCISCO, CAL., October 6.—"1915—San Francisco," is the title of the song that won the prize in the big contest conducted by the Bulletin, of this city, and in which over 2,000 manuscripts were entered. The writers of the song, which is a snappy march, are Philip Irving Jacoby

from the talking machine public as to which of our artists would be the favorite of the public for singing this song when we make the record.

"All our artists are well known. Remember that the song is a lively march. I would like suggestions as to the artist to be sent to our offices at 334 Sutter street at the earliest moment."

"1915—San Francisco" will be sung in vaudeville throughout the West and be featured wherever possible on the Pacific Coast. With the unusual amount of publicity the song will receive, it is certain that the writers will realize an amount in royalties from publishing and mechanical rights that will prove a prize of most substantial proportions.

The judges held several meetings in the music room of the Orpheum Theater before being able to decide upon the winning song, and the accompanying illustrations show Mr. Gray standing at the piano listening to the prize song as played by E. M. Rosner, the talented musical director of the Orpheum Theater in this city.



Judges of San Francisco Prize Song Contest.

Left to right: Charles K. Field, George H. Perry, W. S. Gray, W. R. McArthur, Miss Bessie Beatty and P. H. Beck. At the piano, Charles and his brother Samuel, of 3747 Clay street, the former writing the music and the latter the words.

The judges of the contest were: George Hough Perry, publicity director of the Panama-Pacific Exposition; Edmund M. Rosner, musical director of the Orpheum Theater; Charles K. Field, editor of Sunset Magazine; W. R. McArthur, sales manager of the Eilers Music Co.; P. H. Beck, manager of the talking machine department of the Kohler & Chase Music Co.; Mrs. D. E. F. Easton, prominent club woman and experienced leader in amateur theatricals; Miss Bessie Beatty, of the Bulletin.

Walter S. Gray, Pacific Coast manager for the Columbia Graphophone Co., took particular interest in the contest, and before the prize song was selected made plans whereby it is to be recorded on Columbia records, and thus be featured throughout the country.

In order to add as much as possible to the popu-



E. M. Rosner at Piano, W. S. Gray, Standing. larity of the song, Mr. Gray made the following public request, which met with steady response:

"The Columbia Graphophone Co. realizes that this is the people's song, chosen in a popular contest. Accordingly we would welcome suggestions

from the talking machine public as to which of our artists would be the favorite of the public for singing this song when we make the record.

COMPANIES TO DISSOLVE.

(Special to The Talking Machine World.)

TRENTON, N. J., September 28.—The Edison Business Phonograph Co., capitalized at \$300,000, and the Mexican National Phonograph Co., capitalized at \$25,000, both New Jersey corporations, filed articles of dissolution with the Secretary of State to-day. Thomas A. Edison was the principal stockholder in both companies.

Harry F. Miller, a director in Thomas A. Edison, Inc., in answer to an inquiry said that the two companies had practically been owned by Mr. Edison, and that for purposes of business economy they had been dissolved so that they might be absorbed by Thomas A. Edison, Inc. All of their business, he said, would be carried on by this company.

DECLINE IN PHILIPPINE TRADE.

In an interesting article listing the imports and exports of the Philippine Islands, published in a recent issue of the Daily Consular and Trade Reports, it is pointed out that the imports of talking machines from the United States to that country for the year 1913 decreased more than 50 per cent., as compared with the figures for 1912. In 1913 the value of the phonographs imported from this country totaled only \$20,591, while in 1912 the figures reached \$43,169, indicating that this market was neglected by the American manufacturers last year.

VICTORS IN "ENGLISH BROWN."

The Victor Talking Machine Co. sent out to its dealers recently the following announcement:

"The new shade of mahogany finish known as 'English Brown' is gaining much favor generally. We have therefore decided to add this to our special finishes in styles IX, X, XI, XIV and XVI. The delivery of this finish will be subject to the usual special finish delay, but we will now accept orders through our distributors for this finish and will make a special effort to fill the first orders a little more promptly than we have been able to fill regular special finish orders in the past."

With a lot of chaps Opportunity's knock proves a knockout.

**STOP!
READ!
ACT!**

Are you interested in an attractive business proposition?

We say attractive—yes, exceptionally attractive.

We rank among the largest producers of pianos and player-pianos in the world.

There are a good many piano prospects which enter your store, Mr. Talking Machine Dealer—a good many. Why let them get by you into a regular music store?

We can tell you how to stop them and at the same time stop the dollars which get away from you when the trade leaves your store.

We have an ideal proposition for the talking machine dealer.

Take it up with us, will you? It will only require a small part of your store and practically little or no trouble.

H. P. NELSON COMPANY
816 No. Kedzie Avenue, Chicago, Ill.

LATEST PATENTS RELATING TO TALKING MACHINES AND RECORDS

(Special to The Talking Machine World.)

WASHINGTON, D. C., October 10.—PHONOGRAPH HORN. Adolph G. Soistmann, Camden, N. J. Patent No. 1,100,849.

The object of this invention is to provide a horn of wood or other fibrous material having a flaring or bell-shaped mouth. The object is to produce a horn which shall be extremely light in weight and which shall be so constructed as to maintain its shape and so that its component parts shall be held firmly together without being affected undesirably either by changes in temperature or other atmospheric conditions and also to produce a horn which shall have satisfactory acoustic properties. It seems to be well recognized in the art that the wooden horn is the most satisfactory horn for phonograph purposes both from acoustic considerations and also for considerations of appearance where different kinds of wood may be used to match other parts of the machine. It has also been found that the flaring or bell-mouthed formation is the shape of the horn which is now universally demanded, and consequently which must be supplied by successful manufacturers and dealers.

The flaring horn, made of tapered strips, requires that each tapered strip be bent in one direction to secure the circular cross-section of the

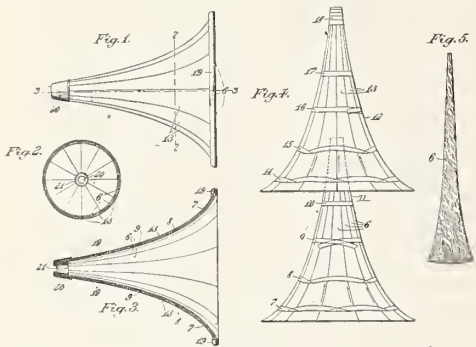

horn, while a large part of its longitudinal extension must be bent in the transverse direction to secure the flare of the horn. This double or transverse bending of a normally flat piece of wood sets up internal stress in each strip of wood, tending to cause said strips to return to their normal flat condition. This tendency, if not counteracted, would result in separation of the strips forming a horn of the bell or flaring shape.

The wooden horn which has had the most extended success up to the present time is made of a plurality of horn shaped layers, each layer composed of separate composite strips of cross-grained veneer, and the flare is made by separating the strips at the flaring end of the horn and inserting filling pieces. It has been found, however, that a much less expensive horn can be made in which the component parts will afford sufficient reinforcement to each other to overcome the internal stress above referred to, to maintain the structure in good condition and without employing separate composite strips of cross-grained veneer, and without employing filling pieces between the separated strips at the flaring end of the horn.

Referring to these drawings, Fig. 1 is a side elevation of the horn. Fig. 2 is a cross-section on line 2-2 of Fig. 1 with the rim 19 omitted. Fig. 3 is a longitudinal section on line 3-3 of Fig. 1. Fig. 4 is an elevation of the two co-operating horn shaped shells, one adapted to superimpose the other, the view showing one shell partly inserted within the other. Fig. 5 is an elevation of a tapered strip.

PHONOGRAPH. Walter H. Miller, Orange, N. J. Patent No. 1,108,208.

This invention is preferably embodied in an attachment to a phonograph of well known form which is in common use and which is normally equipped with a reproducer adapted for reproducing from a sound record the record groove of which is of constant depth and laterally undulating. The reproducer point for playing such records is

ordinarily known in the art as a "needle" and such needle and the reproducer or sound-box of which it forms a part are not adapted for playing records of other types, as for instance, the type of record in which the sound groove is vertically undulating. Records of the character last referred to, however, could be reproduced upon the phonograph without any change therein other than the substitution of a reproducer adapted for such records in place of that with which the machine is normally equipped and which carries a reproducing stylus of the needle type. In accordance with this invention a second reproducer is provided for this purpose. It is desirable that the attachment of such second or additional reproducer for the purpose of adapting the phonograph to play a different type of record shall be made as simply as possible and in particular that there be no necessity of doing machine work upon the phonograph to adapt it for the attachment of the additional reproducer, as there are large numbers of such machines of the type in the hands of users, who are not equipped to make such changes themselves and who would not go to the expense and trouble of having alterations made in their machines. The inventor has devised a means whereby an additional reproducer may be applied to such phonographs in an extremely simple manner and without the necessity of making any changes whatever in the machines now in existence beyond the simple removal of a nut and its replacement by other parts which may be furnished with the additional reproducer.

Among the objects of this invention are the provision of novel means whereby a phonograph may be adapted for the reproduction of records of different types, the making of an attachment for the purpose named in such form that it can be readily attached to the phonograph without derangement of the parts thereof and without the necessity of doing machine or similar work upon the phonograph, the provision of means whereby the sound may be conveyed either from the reproducer with which the machine was originally equipped or from the reproducer of the attachment without loss or interference, and the provision of means for supporting the additional reproducer of the attachment in inoperative position where it will be out of the way when not in use.

In the drawings forming a part of this specification, and wherein the same reference numerals are uniformly applied to designate the same parts

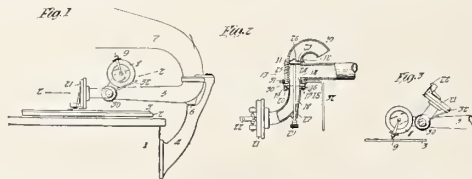

throughout, Fig. 1 is a fragmentary side elevational view of a phonograph of the type with which the attachment is adapted to be used, equipped with a second reproducer and embodying the invention; Fig. 2 is a view, partly in horizontal cross section, of the parts illustrated in Fig. 1, the sectional portion being taken on the broken line 2-2, Fig. 1; and Fig. 3 is a fragmentary side view similar to Fig. 1, but showing the two reproducers arranged in reverse relation from that shown in Fig. 1.

TALKING MACHINE. Clinton E. Woods, Bridgeport, Conn., assignor to American Graphophone Co., same place. Patent No. 1,108,301.

This invention relates to the sound-conveyor employed in talking machines for connecting the sound-box with the amplifying horn. This conveyor is frequently referred to in the art as a "tone-arm."

One object of the invention is to produce a tone-arm that is correctly designed, from an acoustical point of view, and with a continuous and unobstructed passageway for the sound waves from the vibrating diaphragm to the horn.

Another object is the production of a tone-arm which shall be free from vibration and free from

rattling of the parts, yet capable of universal movement.

A further object is the production of a standardized tone-arm; that is, one which can be used to equal advantage on a "visible horn" machine or a "concealed horn" machine, at the same time being simple and efficient in construction and attractive in appearance.

Fig. 1 is a side view of a portion of the so-called "tone-arm" or sound conveyer, mounted for use

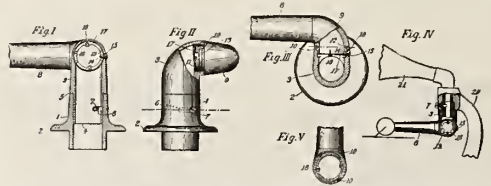

with "concealed horn" talking machine so-called, showing the mounting therefor in vertical section; Fig. 2 is an end view of the same, looking from the right of Fig. 1, and partly in section; Fig. 3 is a plan view of Fig. 1, partly in horizontal section; Fig. 4 is a side view showing the tone-arm in connection with a "visible horn" machine, and Fig. 5 is a sectional view showing details.

TONE ARM FOR TALKING MACHINES. Clinton E. Woods, Bridgeport, Conn., assignor to the American Graphophone Co., same place. Patent No. 1,108,302.

The present invention relates to tone-arms for talking machines, the object of the invention being to provide a device of the character described which will permit the sound-box to have an universal movement, which will be as nearly as possible perfect acoustically and mechanically, and in which the possibility of sympathetic vibration will be reduced to a minimum. Briefly stated, these objects are attained by providing in the tone-arm a continuous, constantly expanding uninterrupted passage, to the end that the sound waves are delivered with an increased volume; and in reducing to a minimum the number of parts and uniting the

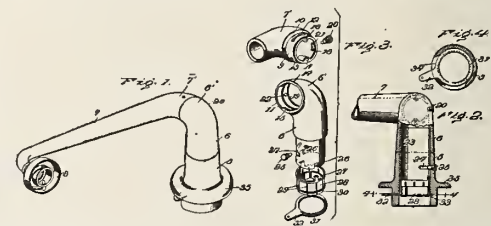

several members of the tone-arm by smooth, tight, practically frictionless joints which obviate the possibility of rattling and the introduction of any extraneous sound.

The improved tone-arm is provided with a horizontal section and a vertical section, and the horizontal section is preferably secured to the vertical section by a bayonet joint connection which is entirely concealed and thoroughly effective and durable.

The present invention is such that, while the volume of sound is increased, the size of the tone-arm is largely decreased over those heretofore employed.

Fig. 1 is a perspective view of the tone-arm; Fig. 2 is a vertical section, partly in elevation; Fig. 3 is a detail showing various coating parts separated, and Fig. 4 is a section on line 4-4 of Fig. 2.

PHONOGRAPH. Charles P. Trundy, Boston, Mass. Patent No. 1,110,165.

The present invention relates to an improvement in phonographs. In machines adapted for reproducing sounds from hill-and-dale cut records, the sound box is rigidly supported on the end of the tone tube which is fed laterally across the record as the needle point travels along the record groove. The spacing of the grooves is not always uniform with the feed of the tone tube, and provision is made for inequalities between the feed demanded by the record groove and the feed of the tone tube by mounting the needle upon the sound box in such a way as to permit slight movements of the needle support with respect to the tone tube in order that the needle may correctly adapt itself to the sound groove. Machines of the hill-and-dale type impart vertical vibrations to the reproducing needle and

LATEST PATENTS RELATING TO TALKING MACHINES—(Continued from page 60).

they are not, therefore, adapted to reproduce sounds from lateral cut records in which the sound vibrations are represented by lateral undulations of the sound groove. These records impart lateral vibrations to the needle point and the needle arm transmits these vibrations to the diaphragm which is mounted in position to receive the lateral vibrations imparted to it by the record through the medium of the needle and needle arm. In order to adapt the hill-and-dale machine to reproduce sounds from lateral cut records it is necessary that it be provided with a lateral cut record sound box and a flexible connection between such sound box and the tone tube.

The object of the present invention is to produce a connection tube for hill-and-dale phonographs for connecting the sound box to the tone tube so as to adapt it to use lateral cut records.

In the accompanying drawings Fig. 1 is a side elevation of a portion of a hill-and-dale machine

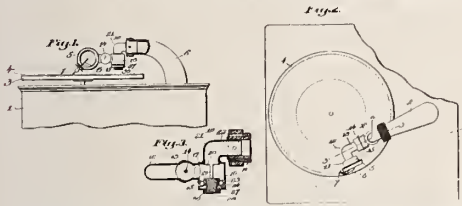

provided with the connection tube of the present invention; Fig. 2 is a plan of such machine, and Fig. 3 is a longitudinal section of the connecting tube between the tone tube and the sound box taken on the line 3-3 Fig. 2.

SOUND REPRODUCING MACHINE. Hyman E. Markle, Nashville, Tenn. Patent No. 1,111,716.

This invention relates to sound reproducing machines generally, but more particularly to the multiplex cylinder machine wherein are employed a series of cylinders with means to bring the cylinders successively into operative relation with the reproducer, and it is the object of the invention to improve and simplify this type of machine.

In the drawings Fig. 1 is a side elevation of a phonograph embodying the invention. Fig. 2 is a front elevation of the same. Figs. 3 and 4 are side

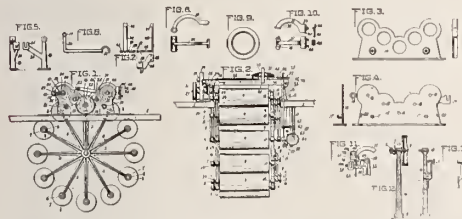

elevations of the castings constituting the gear housing. Figs. 5, 6, 7 and 8 are detail views. Fig. 9 is a top plan view of the carriage. Fig. 10 is a top and side view of the arch bar which supports the front of the carriage, the pawl being shown in position for assembling with said bar. Fig. 11 is a detail elevation of the trip mechanism. Fig. 12 is a detail sectional view through one of the arms of the star wheel and cylinder. Fig. 13 is a similar view of opposite star wheel and one of its hinged sections.

SOUND MODIFIER. Thomas A. Edison, Llewellyn Park, West Orange, N. J., assignor to the New Jersey Patent Co., same place. Patent No. 1,110,382.

This invention relates to devices for modifying or varying the volume or loudness of sound produced by a phonograph or talking machine. Such devices as commonly used comprise a metallic part, such as a butterfly valve, located at some point in the sound conveyer, which valve is opened to a greater or less extent to vary the area of cross section of the conveyer through which the sound reproducer passes. Such a device is objectionable because of the sharp angular deflection of the sound from the metallic surface. A sound modifier should be of such nature as to permit the sound vibrations to pass through the same without deflection even when the modifier is in closed position, the intensity or amplitude of the vibrations being, however, lessened by their passage through the modifier.

One of the objects of the invention accordingly is to produce an efficient and serviceable device of this character.

Fig. 1 represents a vertical central section through a talking machine provided with a modifier embodying this invention, certain parts being shown in side elevation; Fig. 2 represents on an enlarged scale partly broken away of a cross section on line 2-2 of Fig. 1; Fig. 3 is a fragmentary view showing in side elevation and section a portion of a sound conveyer provided with a modification of the sound modifier; Fig. 4 is a detail sec-

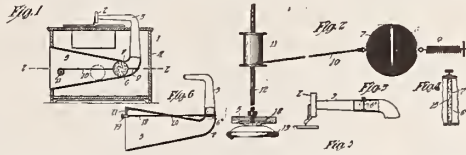

tional view showing the sound modifier of Fig. 3 on an enlarged scale; Fig. 5 represents in section another modification of the device adapted to be used in place of the modifier shown in Figs. 3 and 4, and Fig. 6 represents a partial section through a sound conveyer similar to that shown in Fig. 1, provided with a sound modifier similar to that illustrated in Figs. 3 and 4.

SIGNAL. Albert L. Maillard and Louis H. Crook, Washington, D. C. Patent No. 1,109,684.

The invention relates to signals and more particularly to that class of signals known as alarms and has for an object to provide a signal for producing the sounds of instruments and the like or for reproducing the voice.

The invention embodies more particularly a signal adapted for use on vehicles such as automobiles and the like or on motor boats and ships and wherein it is desired to provide a means whereby the voice or voices of a human being or beings can be reproduced to act as a signal, the device being also adapted for use in producing musical or other sounds.

The invention further embodies a device in which use is made of a record adapted to contain a wave line and similar in many respects to the usual phonograph record, the device being preferably electrically operated whereby, when the record is rotated, a stylus carried by a reproducer operates over the wave line to produce the desired sound.

Fig. 1 is a fragmentary side elevation of a vehicle having our device attached thereto; Fig. 2 is a vertical sectional view of the casing in which the signal is arranged, showing the various parts of the signal in side elevation; Fig. 3 is a horizontal sectional view of the casing, taken on the line 3-3 in Fig. 2, showing the various parts of the signal in plan; Fig. 4 is a vertical transverse sectional view of the casing, taken substantially on the line 4-4 in Fig. 2; Fig. 5 is a fragmentary vertical sectional view taken on the line 5-5 in Fig. 4; Fig. 6 is a fragmentary enlarged vertical sectional view of the

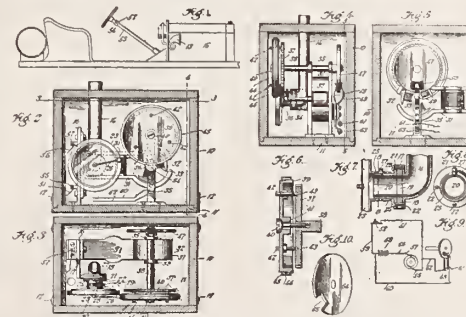

drum, showing the record supported thereon; Fig. 7 is a fragmentary enlarged vertical sectional view, showing the manner of supporting the reproducer in position to convey sounds through the horn; Fig. 8 is a vertical transverse sectional view, taken on the line 8-8 in Fig. 7; Fig. 9 is a diagrammatic view, showing the electrical connection for the device, and Fig. 10 is a perspective view of a modified form of circuit closing member.

BURGLAR ALARM. Alex Stahl, Chicago, Ill. Patent No. 1,111,190.

This invention relates to burglar alarms characterized by a talking machine which is started to give an alarm in the event of a window or door being opened by an intruder.

The invention has for its object to provide novel

and improved means for controlling the talking machine.

Fig. 1 is a perspective view of the apparatus, and

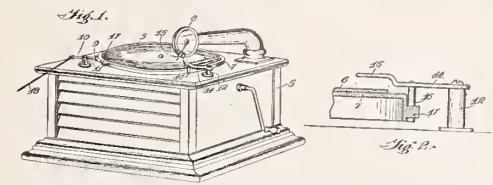
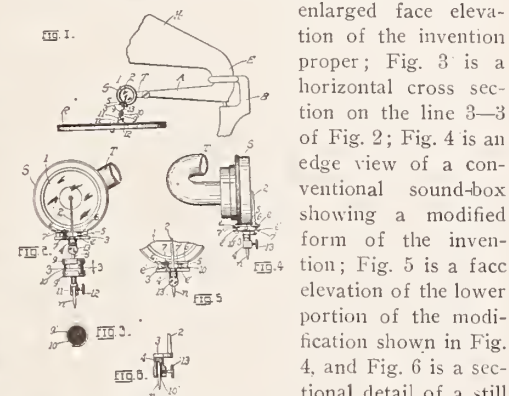

Fig. 2 is a cross section showing a portion of the controlling mechanism.

SOUND REPRODUCING MACHINE. Archibald S. B. Little, Nashville, Tenn. Patent No. 1,108,451.

This invention has relation to improvements in sound reproducing machines and it consists in the novel details of construction more fully set forth in the specification and pointed out in the claims.

In the drawings Fig. 1 is a side elevation of a disc sound reproducer showing the application thereto of one form of this invention; Fig. 2 is an enlarged face elevation of the invention proper; Fig. 3 is a horizontal cross section on the line 3-3 of Fig. 2; Fig. 4 is an edge view of a conventional sound-box showing a modified form of the invention; Fig. 5 is a face elevation of the lower portion of the modification shown in Fig. 4, and Fig. 6 is a sectional detail of a still



further modification.

"MADE IN AMERICA."

Corporation Formed to Promote Sale of Domestic Goods in Foreign Countries.

A nation-wide movement toward giving permanent vitality and efficient direction to the present popular agitation in favor of the home consumption of American-made goods has been launched in this city by a number of men prominent in the commercial, manufacturing and financial world. It is proposed to make "Made in America" mean for the United States what "Made in Germany" has meant for that nation.

The movement took concrete form when articles of incorporation were granted at Albany last week to the Made in America Products Association, Inc., with a nominal capital of \$10,000. The stock is to be issued in shares of \$100 each, and no person, concern, or interest will be allowed to acquire more than one share, which will be requisite for membership in the association.

The first board of directors will include C. A. Whelan, of the United Cigar Stores Co.; Carl J. Schumann, of Moller & Schumann, varnish manufacturers; Harry Tipper, president of the Advertising Men's League; R. A. Holmes, of Crofut & Knapp Co., and Henry Thompson. Temporary headquarters have been opened at 115 Broadway.



Anyone sending a sketch and description may quickly ascertain our opinion free whether an invention is probably patentable. Communications strictly confidential. HANDBOOK on Patents sent free. Oldest agency for securing patents. Patents taken through Munn & Co. receive special notice, without charge, in the Scientific American. A handsomely illustrated weekly. Largest circulation of any scientific journal. Terms, \$3 a year; four months, \$1. Sold by all newsdealers. MUNN & Co. 361 Broadway, New York. Branch Office, 625 F St., Washington, D. C.

RECORD BULLETINS FOR NOVEMBER, 1914.

VICTOR TALKING MACHINE CO.

DANCE RECORDS FOR NOVEMBER.

No.	Title	Size.
35395	Millicent—Waltz Hesitation (Frank W. McKee). McKee's Society Orchestra	12
	Mighty Lak' a Rose—Waltz Hesitation (Nevin-McKee).....McKee's Society Orchestra	12
35400	Old Folks Rag—Fox Trot (W. B. Sweatman) Banjo, Piano and Drums.....Van Eps Trio	12
	Kakulu—Chinese One-step (Felix Arndt) Banjo, Piano and Drums.....Van Eps Trio	12
35402	Same Sort of Girl Medley—One-step, from "The Girl from Utah" introducing "You Never Can Tell".....Victor Military Band	12
	Reuben Fox Trot (Ed. B. Claypoole)..... Victor Military Band	12
35403	The Pavlova Gavotte (The Glow-Worm—Idyll) (Paul Lincke).....Victor Military Band	12
	Melody in F—Half-and-Half (Adapted from Rubinstein).....Victor Military Band	12

POPULAR SONGS FOR NOVEMBER.

17632	When You're a Long, Long Way from Home (Lewis-Meyer).....Henry Burr	10
	In the Palace of Dreams (Daniels-Friedman) Henry Burr	10
17623	Ev'rybody Loves Rag (Dick Howard-Al Harri- man).....Collins and Harlan	10
	Roll Them Cotton Bales (J. W. Johnson-J. R. Johnson).....Heidelberg Quintet	10
17636	The Fatherland, the Motherland, the Land of My Best Girl (Ballard MacDonald-Harry Carroll).....Irving Kaufman	10
	Always Treat Her Like a Baby (Irving Ber- lin).....Irving Kaufman	10
17637	Along Came Ruth (Irving Berlin).....Arthur Fields	10
	I'll Do It All Over Again (A. Seymour Brown- Albert Gumble).....Billy Murray	10
17638	Mary, You're a Little Bit Old Fashioned (Marion Sunshine-Henry L. Marshall).....Chas Harrison	10
	You Planted a Rose (In the Garden of Love) (J. Will Callahan-Ernest R. Ball)..... Charles Harrison	10

NEW RECORDS OF TWO FAVORITE HOME SONGS.

35298	Home, Sweet Home (Payne-Bishop).....Elsie Baker	12
	Old Folks at Home (Stephen C. Foster)..... Elsie Baker	12
35399	Souvenir (Franz Drdla) (Violin with Piano).... Maximilian Pilzer	12
	Lohengrin Fantasie (Wagner) (Violoncello).... Rosario Bourdon	12
35401	Beautiful Galatea Overture (Franz von Suppé) (Patrick Conway, Director).....Conway's Band	12
	Valse Militaire (E. Waldteufel)..... Vessella's Italian Band	12
35404	Gems from "The Girl from Utah" (Harry B. Smith-Jerome D. Kern)..... Victor Light Opera Co.	12
	Gems from "Miss Daisy" (Philip Bartholomae- Sylvio Hein).....Victor Light Opera Co.	12
17639	It's a Long, Long Way to Tipperary (Judge and Williams).....American Quartet	10
	Soldiers of the King—March.....Pryor's Band	10

OTHER PATRIOTIC RECORDS OF THE WARING NATIONS—Selected from "The Victor Catalogue."

GREAT BRITAIN.		
16083	God Save the King and Rule Britannia..... Pryor's Band	10
	Austrian Hymn.....Pryor's Band	10
16134	God Save the King.....Alan Turner and Chorus	10
	Rule Britannia (Arne).....Alan Turner and Chorus	10
AUSTRIA.		
16083	Austria National Hymn—"Gott erhalte Franz" Pryor's Band	10
	Great Britain National Airs.....Pryor's Band	10
16901	Austrian Army Bugle Calls.....Pryor's Band	10
	On the Belvedere—Two-step.....Pryor's Band	10
64408	Austrian Hymn (Haydn) Violin Solo..... Fritz Kreisler	10
GERMANY.		
16138	Die Wacht am Rhein (Wilhelm).....Sousa's Band	10
	Gesundheit Waltz (Helf).....Pryor's Band	10
16423	Die Wacht am Rhein (Wilhelm) In German..... Emil Muench	10
	Lorelei (Silcher) In German.....Emil Muench	10
16882	Die Wacht am Rhein In English..... Reinold Werrenrath	10
	Santa Lucia—Neapolitan Folk Song In English. Reed Miller	10
FRANCE.		
16514	La Marseillaise—National Air of France..... Sousa's Band	10
	Tannhäuser March—Fest March (Wagner).... Sousa's Band	10
74039	La Marseillaise (de Lisle) In French..... Marcel Journet	12
RUSSIA.		
16669	Russian National Anthem.....Pryor's Band	10
	Radetsky March (Strauss).....Pryor's Band	10
MISCELLANEOUS.		
31855	National Airs of All Nations..... Victor Mixed Chorus	12
35288	Reminiscences of All Nations.....Pryor's Band	10
	Creanonian Polka (Cornet) with U. S. Marine Band.....Arthur S. Witcomb	10

BLUE LABEL RECORD.

55946	Mr. Hitchcock's Curtain Speech (Monologue) Introduced in "The Beauty Shop"..... Raymond Hitchcock	12
	Burglar Story and High Cost of Living (Mono- logue).....Raymond Hitchcock	12

PURPLE LABEL RECORDS.

60125	That's an Irish Lullaby (Too-ra-loo-ra-loo-ra!) From Chamcey Olcott's "Shameen Dhu." (J. R. Shannon) Baritone Solo.....Geo. MacFarlane	10
60124	Absent (Catherine Young Glenn-John W. Met- calf) Soprano Solo.....Margaret Romaine	10
60115	Harmony Baby (Bayes-Kleinecke) Soprano Solo. Nora Bayes	10
70110	The Message Boy (Lauder) Song Hit.....Lauder	10
NEW EDUCATIONAL RECORDS.		
17635	Navajo Indian Songs—Tom Tom accomp..... Geoffrey O'Hara	10
	Gambler's Song—Blackfeet Tribe..... Glacier Park Indians	10

35397	Clayton's Grand March (C. D. Blake)..... Victor Military Band	12
	In Lilac Time—March (H. Engelmann)..... Victor Military Band	12

NEW FOREIGN RECORDS.

New Hawaiian Records.		
65971	(a) Kaowe ake Kai (Roaring Sea) Tenor and Male Quartet with Toots Paka Hawaiian Troupe	10
	(b) Lei Rose o Kawika (The Wreath of David) (Montana) Tenor and Male Quartet, Hawaiian Orchestra.....Toots Paka Hawaiian Troupe.	10
65972	(a) Ninipo (I'o Love)..... Toots Paka Hawaiian Troupe	10
	(b) Kamawe (Shake Your Feet)..... Toots Paka Hawaiian Troupe	10
RED SEAL RECORDS FOR NOVEMBER.		
64399	Serenata (Iue Serenade) (Tosti) Soprano Solo in Italian.....Alma Gluck	10
64420	Tosca—Recondita Armonia (Strange Harmony) (Act I) (Puccini) Tenor Solo in Italian..... Giovanni Martinelli	10
64430	Because (Poem by Edward Teschemacher) (Guy D'Hardelot) Tenor Solo in English..... John McCormack	10
64445	An die Musik (To the Music) (Op. 88, No. 4) (Schuber-Schubert) Mezzo-soprano in German; pianoforte by Arthur Arndt.....Margaret Ober	10
64459	Silver Threads Among the Gold (Transcription) (H. P. Danks) Violin Solo; pianoforte by George Falkenstein.....Maud Powell	10
74407	Bohemian Girl, The Heart Bow'd Down (Act 2) (Balfe) Baritone Solo in English..... Clarence Whitehill	12
74410	The Cross (Poem by Edward Markham) (Harriet Ware) Tenor solo in English. Evan Williams.	12
87168	Good Morning, Sue! (Bonjour, Suzon!) (Leo Delibes) Contralto Solo in English..... Ernestine Schumann-Heink	10
87190	Malaguena (Pagans) Soprano in Spanish..... Lucrezia Bori	10
88474	Traviata-Di Provenza il mar (Thy Home in Fair Provence) (Act 2) (Verdi) Baritone Solo in Italian.....Pasquale Amato	12
88476	Il Bacio ((Vocal waltz—"The Kiss") (Arditi) Soprano Solo in Italian.....Frieda Hempel	12
88483	Lullaby from Jocelyn ("Angels Guard Thee") (Benjamin Godard) Tenor Solo with Fritz Kreisler, violinist and pianoforte, Vincent O'Brien in English.....John McCormack	10
88506	Linda di Chamounix—O luce di quest' anima (Guiding Star of Love) (Act I) (Donizetti) Soprano Solo, in Italian.....Luisa Tétrazzini	12
89080	Rigoletto—Quartet—Pella figlia dell' amore (Fair- est Daughters of the Graces) (Act III) (Verdi) Quartet L. Bori, soprano; J. Jacoby, mezzo-soprano, J. McCormack, tenor; R. Werrenrath, baritone	12

EDISON BLUE AMBEROL RECORDS.

REGULAR LIST.

2443	Die Wacht am Rhein.....Edison Concert Band	10
2460	Dreams of the Prisoner (Jungmann)..... American Standard Orchestra	10
2446	First Love—Waltz Hesitation (Abe Holzmann) for dancing.....National Promenade Band	10
2438	God Save the King. Baritone Solo..... National Military Band and Peter Dawson	10
2458	Humpty Dumpty Rag (Charles Straight)..... New York Military Band	10
2457	In the Evening by the Moonlight, Dear Louise (Von Tilzer) Tenor Solo and Chorus, orch. accomp.....Harvey Hindermeyer and Chorus	10
2439	La Marseillaise.....New York Military Band	10
2449	Let's Grow Old Together, Honey (McDonald, Mc- Keon and Walker) Tenor Solo, orch. accomp... Manuel Romain	10
2454	Love's Dream After the Ball—Vocal (Czibulka) Soprano Solo, orch. accomp.....Elizabeth Spencer	10
2452	Love's Sorrow (Harry Rowe Shelley) Tenor Solo, orch. accomp.....Emory B. Randolph	10
2447	Massa's in de Cold, Cold Ground (Stephen C. Foster) Mixed voices, orch. accomp..... Metropolitan Quartet	10
2455	Meet Me 'Neath the Persian Moon (Friedland) Tenor Solo, orch. accomp.....Walter Van Brunt	10
2456	My Croony Melody (Goetz and Goodwin) Coon Duet, orch. accomp.....A. Collins and B. G. Harlan	10
2451	Navajo Indian Songs. Baritone Solo..... Geoffrey O'Hara	10
2448	Roll Them Cotton Bales (J. Rosamond Johnson) Male voices, orch. accomp.....Premier Quartet	10
2459	Since I Am Your Auntie-to-Be—The Midnight Girl (Briquet and Philipp) Soprano and Tcnor Duet, orch. accomp.....Elizabeth Spencer and Walter Van Brunt	10
2453	Somewhere a Voice is Calling (Arthur F. Tate) Soprano and Baritone Duet, orch. accomp..... Elizabeth Spencer and Vernon Archibald	10
2450	Sweet Spirit, Hear My Prayer (Wm. V. Wallace) Soprano and chorus, orch. accomp..... Maria Narelle and Chorus	10
2445	Tickle Toes One-step (William H. Penn) For dancing.....National Promenade Band	10
2437	When It's Night Time Down in Burgundy (Her- man Paley) Contralto and Tenor Duet, orch. accomp.....Helen Clarke and Walter Van Brunt	10

COLUMBIA GRAPHOPHONE CO.

SYMPHONY DOUBLE DISC RECORDS.		
A1573	The Ninety and Nine (Sankey). Baritone Solo, in English, with orch. accomp.....Oscar Seagle	10
	Help Me To Pray (Tosti) Baritone Solo, in English, with orch. accomp.....Oscar Seagle	10
A1591	I Hear a Thrush at Eve (Cadman) Soprano Solo in English, orch. accomp. Carolina White	10
	A Birthday (Woodman) Soprano Solo, in English, with orch. accomp.....Carolina White	10
SYMPHONY DISC RECORDS.		
A5597	Berceuse (Chopin). Piano Solo..... L. Godowsky	12
	Waltz in G Flat (Chopin). Piano Solo..... Leopold Godowsky	12

36907	Ave Maria (Schubert). Violin Solo..... Eugen Msyae	12
BLUE-LABEL DOUBLE-DISC RECORDS.		
A1588	Kamawee (Move Your Feet) (Huila). Tenor Solo with chorus...Toots Paka Hawaiian Co.	10
	Ahi Ahi Poakolu (Wednesday Evening). Tenor Solo with chorus...Toots Paka Hawaiian Co.	10
A1590	A Trip Across the Pond (Arr. by M. Bernard) Piano Solo.....Mike Bernard	10
	Tango Bonita (Smith). Piano Solo.....M. Bernard	10
A5594	Die Walkure (Wagner). Magic Fire Scene... Columbia Smyp. Orch., F. Weingartner, Cond.	12
	Symphonie Pathetique No. 6 (Tschaiikowsky). First Movement..... Columbia Smyp. Orch., F. Weingartner, Cond.	12

NOVEMBER SONG HITS.		
A1592	The High Cost of Loving (Meyer). Contralto Solo, orch. accomp.....Elida Morris	10
	I Want to Go Back to the Farm (Berlin). Con- tralto Solo, orch. accomp.....Elida Morris	10
A1596	Alice of Old Vincennes (Thompson). Tenor Solo, orch. accomp.....Henry Burr	10
	Diana of the Green Van (Klickmann). Con- tralto Solo, orch. accomp.....Nora Watson	10
A1601	California and You (Puck). Tenor Duet, orch. accomp.....A. Campbell (1st), H. Burr (2d)	10
	In the Shadow of the Sycamore (Bennett). Tenor Duet, orch. accomp..... A. Campbell (1st), H. Burr (2d)	10
A1600	The Aha Daba Honeymoon (Fields and Dono- van). Baritone and Tenor Duet, orch. ac- comp.....Arthur Collins and Byron G. Harlan	10
	The Aeroplane Slide (Reed). Orch. accomp... Peerless Quartet	10
A1062	The Whole Town's Wise (Richards). Soprano and Tenor Duet, orch. accomp..... Ada Jones and Henry Burr	10
	When Honey Boy and Honey Girl Go On Their Honeymoon (Goetz). Soprano and Tenor Duet, orch. accomp..... Ada Jones and Henry Burr	10
A1597	The Whistling Coquette (Belmont). Soprano and Baritone Duet, orch. accomp..... Ada Jones and Joe Belmont	10
	How'd You Like to Keep a Date With Me (Goetz). Soprano and Tenor Duet, orch. accomp.....Ada Jones and Henry Burr	10
A1586	The Boys of the Old Brigade (Parks). Chautauqua Preachers' Quartet	10
	The Church in the Wildwood (Pitts)..... Chautauqua Preachers' Quartet	10
A1587	Shylock's Justification of the Jew, from "The Merchant of Venice" (Shakespeare). Dra- matic Recitation.Harry E. Humphrey	10
	Seven Ages of Man, from "As You Like It" (Shakespeare). Dramatic Recitation..... Harry E. Humphrey	10
A1589	Venetian Love Song, from "A Day in Venice" (Nevin).....Prince's Orchestra	10
	March of the Little Lead Soldiers (Pierne).... Prince's Orchestra	10
A1595	San Antonio Swing (Buford).....Prince's Band	10
	El Pagare.....Prince's Band	10

DOUBLE DISC RECORDS.

A1598	Wedding of the Winds Waltz (Hall). Accor- deon Solo.Pietro Deiro	10
	La Sirena (Waldteufel). Accordeon Solo.... Pietro Deiro	10
A1599	The Blacksmith and His Anvil (Von der Meh- den).....Prince's Orchestra	10
	Woolley Winks March (Martin).....Prince's Band	10
A5596	The Old Sexton (Russell). Bass Solo, orch. accomp.....Miles R. Bracewell	12
	When Richeleu the Red Robe Wore (Murray). Bass Solo, orch. accomp.....M. R. Bracewell	12
S7520	Flashing Glory March (Martin).....Prince's Band	12
	The Life Guard March (Martin).....Prince's Band	12

NEW DANCE RECORDS.

A1593	My Hindoo Man (Eugene)—One-step..... Van Eps Banjo Orchestra	10
	Thanks for the Lobster (Jones)—One-step. . Van Eps Banjo Orchestra	10
A1594	Sans Souci (Green)—Maxixe Bresilienne..... Van Eps Banjo Orchestra	10
	Some Baby (Lenzberg)—One-step..... Van Eps Banjo Orchestra	10
A5595	Ballin' the Jack (Smith)—Fox-trot..... Prince's Band	12
	Meadowbrook FoX-Trot (Kraus).....Prince's Band	12
A5598	High Society (Smith)—Combination One-step and Waltz.....Prince's Band	12
	Ta Tao (Penn).....Prince's Band	12
A5599	Carolina (Vodery)—Fox-trot.....Prince's Band	12
	Tsing Tsing (Onivas).....Prince's Band	12
A5600	The Old Homestead (Penn)—Fox-trot..... Prince's Band	12
	Dream of the Rose (On themes from Waldteu- fel Waltzes—Arr. by Smith)—Waltz Hesita- tion.....Prince's Band	12

NOW MAKING CARBOLIC ACID.

Word was received recently from the Edison plant at West Orange, N. J., that Thomas A. Edison has overcome the shortage of importations of German and English made carbolic acid, used extensively in his plant, by making successfully in the Silver Lake Chemical Works his own carbolic acid for the first time, an acid said to be superior to the imported article and produced more cheaply.

RECEIVER FOR V. J. DOYLE.

R. B. Caldwell, vice-president of the Blackman Talking Machine Co., Victor distributor, was appointed receiver recently by George R. Beach, referee in bankruptcy, in the case of Vincent J. Doyle, 60 Newark avenue, Jersey City, N. J., Victor dealer, who was adjudged bankrupt. Among the larger creditors are the New York Talking Machine Co. and Blackman Talking Machine Co.

Kranich & Bach have taken on the Victor talking machine line in their store on 125th street.

It's hard to teach a man anything when he doesn't even know when he is licked.

CHEMISCHE FABRIK E. SAUERLANDT FLURSTEDT
 The largest manufacturing plant in the world devoted exclusively to the
 manufacture of Master-Waxes and Master-Blanks for
Gramophone and Phonograph Recording
 Sole Manufacturer of Wax "P." the best recording material for Berliner-cut.

Leading Jobbers of Talking Machines in America



Where Dealers May Secure
COLUMBIA
Product

Ready, Full Stocks, and Prompt Deliveries from Convenient Shipping Centers all over the United States.

Distributors

- Atlanta, Ga., Columbia Graphophone Co., 132 Peachtree St.
- Baltimore, Md., Columbia Graphophone Co., 305-307 North Howard St.
- Birmingham, Ala., Columbia Graphophone Co., 1818 Third Ave.
- Boston, Mass., Columbia Graphophone Co., 174 Tremont St.
- Buffalo, N. Y., Columbia Graphophone Co., 622 Main St.
- Chicago, Ill., Columbia Graphophone Co., 14 N. Michigan Ave.
- Cincinnati, O., Columbia Graphophone Co., 117-119 W. Fourth Ave.
- Cleveland, O., Columbia Graphophone Co., 1375 Euclid Ave.
- Dallas, Tex., Southwestern Talking Machine Co., 1101 Elm St. Columbia Building
- Denver, Colo., Columbia Stores Co., 505-507 Sixteenth St.
- Detroit, Mich., Columbia Graphophone Co., 114 Broadway.
- Hartford, Conn., Columbia Graphophone Co., 719 Main St.
- Indianapolis, Ind., Columbia Graphophone Co., 27 N. Pennsylvania St.
- Kansas City, Mo., Columbia Graphophone Co., 1112 Grand Ave.
- Lincoln, Nebr., The Grafonola Company, 1038 O St.
- Livingston, Mont., Scheuber Drug Co.
- Los Angeles, Cal., Columbia Graphophone Co., 420-422 S. Broadway.
- Louisville, Ky., Columbia Graphophone Co., 425 South Fourth St.
- Milwaukee, Wis., Albert G. Rande, 615 Grand Ave.
- Minneapolis, Minn., Columbia Graphophone Co., 424 Nicollet Ave.
- New Haven, Conn., Columbia Graphophone Co., 25 Church St.
- New Orleans, La., Columbia Graphophone Co., 933 Canal St.
- New York City, Columbia Graphophone Co., 89 Chambers St.
- Philadelphia, Pa., Pennsylvania Talking Mach. Co., 1109 Chestnut St.
- Pittsburgh, Pa., Columbia Graphophone Co., 810 Bessemer Building.
- Portland, Me., Columbia Graphophone Co., 550 Congress St.
- Portland, Ore., Columbia Graphophone Co., 371 Washington St., Ellers Music House.
- Providence, R. I., Columbia Graphophone Co., 119 Westminster St.
- Rochester, N. Y., The Grafonola Company, 23 Clinton Ave., South.
- Sacramento, Cal., Kirk, Geary & Co.
- Salt Lake City, Utah, Daynes-Beebe Music Co., 45 Main St.
- San Francisco, Cal., Columbia Graphophone Co., 334 Sutter St.
- Seattle, Wash., Columbia Graphophone Co., 1311 First Ave.; Ellers Music House, 3d and University Sts.
- Spokane, Wash., Columbia Graphophone Co., 818 Sprague Ave.
- Springfield, Mass., Columbia Graphophone Co., 174 Worthington St.
- St. Louis, Mo., Columbia Graphophone Co., 1008 Olive St.
- St. Paul, Minn., Columbia Graphophone Co., 17 East Sixth St.
- Tampa, Fla., Tampa Hardware Co.
- Terre Haute, Ind., 640 Wabash Ave.
- Toledo, O., Columbia Graphophone Co., 229 Superior St.
- Washington, D. C., Columbia Graphophone Co., 1210 G St., N. W.

DEALERS WANTED—Exclusive selling rights given where we are not actively represented.

Write for particulars to the Columbia Graphophone Co., Wholesale Department, Woolworth Building, New York.

Headquarters for Canada:

Columbia Graphophone Co., 363-5-7 Sorauren Ave.

Toronto, Ont.

Southern Victor Dealers

Largest Stock VICTROLAS and RECORDS.
Prompt Shipment and Low Freight Rates.

WALTER D. MOSES & CO.
Oldest Music House in Virginia or North Carolina.
RICHMOND, VA.

SERVICE FIRST

EXCLUSIVE VICTOR JOBBERS
WHOLESALE ONLY

Standard Talking Machine Co.
PITTSBURGH, PA.

Edison Phonograph Distributors

for the SOUTHWEST
All Foreign Records in Stock.

Houston Phonograph Co., HOUSTON, TEXAS

NEW ENGLAND
JOBBER HEADQUARTERS
EDISON AND VICTOR

Machines, Records and Supplies.
THE EASTERN TALKING MACHINE CO.
177 Tremont Street BOSTON, MASS.

PACIFIC COAST DISTRIBUTORS OF

Victor Talking Machines and RECORDS
STEINWAY PIANOS—LYON & HEALY
"OWN MAKE" BAND INSTRUMENTS
Sherman, Clay & Co. San Francisco Portland
Oakland Los Angeles

The Chicago Edison Jobber

The perfection of Musical Instruments—THE EDISON diamond disc PHONOGRAPH—with EDISON double disc records.

THE PERFECTION OF SERVICE—Our Service.

The Perfection of advertising for the dealer—Our plan.

The Phonograph Company
229 So. Wabash Ave. CHICAGO

CHASE & WEST DES MOINES IOWA

Machines Records Cabinets **Victor** Everything in stock all the time.

WHOLESALE TO IOWA TRADE

Send us your name and address and we will mail you postpaid complete illustrated catalogues, giving detailed information concerning all Victor products. Showing the various styles of Victor Machines, list of all Victor Records, the entire line of Victor Cabinets, Repair Parts and all Accessories. Dealers, let us help you build a Victor Business.

1856 WURLITZER 1914

VICTOR
DISTRIBUTERS

VICTORS EXCLUSIVELY

We make a specialty of getting the order out on time—every time.

The Rudolph Wurlitzer Co.
CINCINNATI and CHICAGO

Two points of supply; order from the nearer.

PERRY B. WHITSIT L. M. WELLER

PERRY B. WHITSIT CO.,

213 South High Street, Columbus, Ohio.

Edison Phonographs and Records **JOBBERS** Victor Talking Machines and Records

**OLIVER
DITSON
COMPANY**
BOSTON

Largest VICTOR Talking Machine Distributors East of Chicago.

Creators of "The Fastest Victor Service." Let us tell you more about our service.

W. J. DYER & BRO.
Saint Paul, Minn.

VICTOR & EDISON
Distributors

Quick Service for all points in the Northwest. Machines, Records, Supplies.

Do you belong with—"the quick or the dead"

Every talking machine jobber in America should be represented in The World of November 15th.

If you are keenly alive to your business interests you will be with the live ones and occupy space in the issue of The World of that date.

The time to secure space is now, and get your copy in at once. Don't be a "dead one."



All the eloquence needed to sell an Edison Phonograph is bound up in the instrument itself. Its playing carries conviction, inevitably.

To make that conviction work for your profit it is only necessary to be sure that you carry the full Edison line.

Thomas A Edison
INCORPORATED

59 Lakeside Ave., ORANGE, N. J.



The **TALKING**
MACHINE
WORLD

AND
 NOVELTY
 NEWS

Published Each Month by Edward Lyman Bill at 373 Fourth Avenue, New York, November 15, 1914



Victrola XVI, \$200
 Mahogany or oak

The instrument by which the value of
 all musical instruments is measured





INSTALLATION FOR THE AEOLIAN CO.



INSTALLATION FOR NEAL, CLARK & NEAL CO.

Unico Demonstrating Booths

Will Sell MORE Talking Machines

These booths are built on the Unit system; can be taken down and put up again in a few hours; made in multiples of three feet, so you can enlarge or reduce your booths as desired, and without labor charges. Every Unit is interchangeable.

Made in eight regular designs, and are both **SOUNDPROOF** and **DUSTPROOF**.

Woods furnished: Oak, Birch, Quartered Oak and Mahogany. Special finishes on order.

Unico Booths increase the sales of Talking Machines, Player-Pianos, Music Rolls and records, for customers always buy better goods—and more goods—with artistic surroundings.

The cost of Unico Booths is less than you would pay in your own City, irrespective of our Patent Construction and Superior Quality.

Just look at this partial list of high-grade houses where Unico Demonstrating Booths are selling more Talking Machines.

- | | |
|------------------------------|-------------------|
| Lyon & Healy | Chicago, Ill. |
| Rudolph Wurlitzer Co. | Cincinnati, O. |
| Frederick Piano Co. | Pittsburgh, Pa. |
| Pease Piano Co. | Brooklyn, N. Y. |
| Gimbel Brothers | New York City. |
| John Wanamaker | Philadelphia, Pa. |
| Krell Piano Company | Cincinnati, O. |
| E. F. Droop & Sons Co. | Baltimore, Md. |
| Aeolian Company | New York City. |
| Lyric Piano Company | Cincinnati, O. |
| Fulton Music Company | Waterbury, Conn. |
| Humes Music Company | Columbus, Ga. |
| Clayton Piano Co. | Salt Lake City. |
| Cunningham Piano Co. | Philadelphia, Pa. |
| R. H. Macy & Company | New York City. |
| B. S. Porter & Son | Lima, Ohio. |
| Neal, Clark & Neal | Buffalo, N. Y. |
| The Aeolian Company | New York City. |
| The Aeolian Company | Cincinnati, O. |
| Koerber-Brenner Co. | St. Louis, Mo. |
| The Allen-Johnson Co. | Eau Claire, Wis. |
| Blackman Talking Machine Co. | New York City. |
| D. S. Andrus | Elmira, N. Y. |
| Stewart Bros. | Columbus, Ohio. |
| Bloomington Bros. | New York City. |
| Block & Kuhl Co. | Peoria, Ill. |
| Paul, Gale Greenwood Co. | Norfolk, Va. |
| Jas. McCreery & Co. | New York City. |
| Linn & Scruggs Dry Goods Co. | Decatur, Ill. |
| Steger & Sons Piano Co. | Newark, N. J. |
| Story & Clark Piano Co. | Chicago, Ill. |
| Andrews Music House Co. | Bangor, Me. |
| Pincus & Murphy | Alexandria, La. |
| Smith-Carroll Co. | Lexington, Ky. |
| Theo. J. Miller & Son | Dixon, Ill. |
| Wm. Taylor, Son & Co. | Cleveland, O. |

THE AEOLIAN COMPANY
AEOLIAN BLDG.
PHILADELPHIA, PA.

CINCINNATI, March 12, 1914.

Messrs. Geo. W. Smith Supply Co.,
30th & Powelton Aves.,
Philadelphia,
Pa.

Gentlemen:

We are much pleased with the talking machine booths, which we secured from you last Fall. They are in every way the most satisfactory demonstration booths we have seen, and have unquestionably been of great assistance in the development of our Victor business.

We find that their first-floor front location is a decided advantage, because the booths are very convenient for shoppers and enable us to give outdoor record service, than formerly.

We had a call yesterday from a piano & talking machine firm, located in another city, whose representative had happened in the store and liked the booths so much that he inquired who built them.

We have had a number of such inquiries and are always glad to recommend the booths in the highest terms.

Yours very truly,
THE AEOLIAN COMPANY

GW:LP

What the Aeolian Co. says about Unico Booths.

Illustrated Catalog and Prices Mailed Upon Request

Geo. W. Smith & Co.

Sloane Street and Powelton Avenue

PHILADELPHIA



The Talking Machine World

Vol. 10. No. 11.

New York, November 15, 1914.

Price Ten Cents

PRICE MAINTENANCE CONTRACT

Of the Columbia Graphophone Co. Again Upheld Against "Violation of the Law" Defense—An Important Legal Proceeding.

The price maintenance contract of the Columbia Graphophone Co. was directly attacked in a case recently decided by Justice Weil of one of the local courts. The Columbia Graphophone Co. brought an action against Wallace F. Bogart, of 1224 Ogden avenue, Bronx, for goods sold and delivered. The defendant made the price maintenance contract a part of his answer and interposed as a defense that "the terms of said agreement were against public policy and in violation of the law." It was stipulated on the record in open court that, if the court found that the contract was a perfectly good and legal one and not against public policy and in violation of the law, judgment should be awarded the plaintiff, the Columbia Graphophone Co. The court, after taking the matter under advisement and reading the briefs submitted by both sides, handed down judgment in favor of the plaintiff and against the defendant for the full amount claimed, with the costs of the action. Mirabeau L. Towns appeared for the defendant.

Columbia dealers will be glad to know that they are operating under a contract which has received the judicial approval of the courts.

It may be well to point out, in this connection, that in the case of Columbia Graphophone Co. against Pickard, 201 Fed. Rep. 546, the court (Hazel, district judge) referred in express terms to the Columbia Graphophone Co.'s price maintenance contract, and to the fact that the selling price was fixed by its terms, holding that the assignee for the benefit of creditors had no greater right than his assignor with respect to the sale of Columbia graphophones and records which were purchased by the assignor under the Columbia Graphophone Co.'s price maintenance contract, and enjoined the assignee from selling said patented articles below the prices authorized by said contract, notwithstanding the fact that the assignee had previously been authorized to do so by a State court. This case, it will also be interesting to note, is the leading case on this subject, and was won on rehearing after a hard fight, in which the assignee, himself one of the leading lawyers of western New York, took a prominent part. His counsel were Wilson C. Price, James L. Weeks and Weeks & Ross, all distinguished lawyers of Jamestown and Buffalo. E. K. Camp appeared for the Columbia Graphophone Co. in both cases.

BELIEVED IN REALISM.

The Globe Talking Machine Co., 9 West Twenty-third street, New York, of which David Kahn is manager, had an interesting window display recently to attract attention to the new Victor record of "It's a Long, Long Way to Tipperary." The view showed little leaden soldiers on both sides of and crossing a tiny river, with equipment, etc., faithfully portrayed, and even went so far as to show the hanging of a spy.

The tiny soldiers were shown issuing from between the doors of a Victrola IX placed at one side of the window, and the entire effect, the work of Charles A. Marusak, was most attractive. What is most important, it influenced the sale of many records of "Tipperary."

SMILING.

You might as well keep smilin',
For there aint a bit o' sense
Of fidgetin' an' rilin',
An' a-longin' too intense.
For most things worth the gettin',
Are sure to find the place,
When you're peaceful an' a-settin'
With a smile upon your face.

NEW CONCERNS IN BUFFALO.

Latest Concerns to Enter Talking Machine Field—Business Is Excellent—Neal, Clark & Neal's New Sign—Gould Bros. Quarters.

(Special to The Talking Machine World.)

BUFFALO, N. Y., November 10.—Business in the talking machine field in Buffalo is active, everything considered, and the outlook for the fall and winter trade is good. A number of new talking machine representatives have recently been appointed, namely, John Rae, of Niagara Falls, has taken the agency for the Victrola; Seiber & Hofheins, 705 Main street, this city, motorcycle dealers, have taken the Columbia agency, while W. F. Gould, a prominent hardware dealer of Elk street, has taken the Victrola agency.

Neal, Clark & Neal, local agents for the Victor, have just erected a 9x14-foot electric sign in front of their store, advertising the Victrola. The sign can be read more than two blocks away.

Gould Bros., piano dealers, who recently moved into their new quarters at Main and Utica streets, are handling a complete line of Victor talking machines and records.

TO HANDLE THE COLUMBIA LINE.

New England Furniture and Carpet Co. of Minneapolis, to Give Columbia Products Strong Representation in Northwest.

(Special to The Talking Machine World.)

MINNEAPOLIS, MINN., November 7.—The local distributing branch of the Columbia Graphophone Co. announced this week the consummation of an important deal whereby the New England Furniture and Carpet Co., of this city, will handle the complete line. This company is by far the largest concern of its kind in the Northwest, and controls an enormous trade.

This deal is naturally very gratifying to the Columbia Co., as it completes a trinity of three of the largest houses in the fields where talking machines are the most popular. A few weeks ago was announced a Columbia contract with that great



A THANKSGIVING POEM IN PROSE.

Thanksgiving was approaching and Dorothy was sad, for of all her pets the turkey was the dearest one she had. Old Dinah had informed her that to make the day complete it was always quite essential to have turkey roast to eat. So she went in tears to Daddy, who relieved her sorrow quite. "Don't worry, little girl," he said, "I'll fix it up, all right." On that evening from the office, he brought home his dictaphone, and canned the turkey's song for her. So now while she's alone, she does not miss her pet, you see. O my! his meat was choice, and though she helped to eat him up, she still can hear his voice.

HOWARD TAYLOR MIDDLETON,

department store, Marshall Field & Co., of Chicago. Subsequent to that a deal of tremendous importance was closed with the Aeolian Co., the largest manufacturers of musical instruments in the country.

The New England Furniture and Carpet Co. has for some time recognized the selling possibilities of the Columbia line, and their signing of a contract completed their investigations and trials. An aggressive publicity and sales campaign will be instituted by the company to introduce its Columbia department.

WANAMAKER EULOGIZES EDISON.

The Birthday of the Famous American Inventor Brings a Very Beautiful Tribute from John Wanamaker, the Merchant Prince, Who Sets Forth the Achievements of Edison and What He Has Done for the World.

The advertising editorials of John Wanamaker which adorn the front pages of the New York Herald daily are filled with much interest. They are unique and telling and show the wide range of thought on varied subjects possessed by the great merchant.

The following from the pen of Mr. Wanamaker, heading his trade announcement on October 21, is of peculiar interest to World readers:

THIS IS THE ANNIVERSARY OF
THOMAS A. EDISON'S GREAT DISCOVERY

The conquerors of the world are not all warriors.

The inventors of the world are oftentimes conquerors.

Thirty-five years ago a young mechanic, thirty-two years old, bearing the name of Thomas A. Edison, discovered the incandescent light.

Willing McKean, the old editor of the Public Ledger, at that time with the writer of this anniversary greeting to his old friend, went down to Menlo Park, in October, 1879, to see the wonderful lamp exhibited to them by the modest young Edison.

What Mr. Thomas A. Edison has achieved to date places his name upon the roll with Galileo, Columbus, Franklin.

To-day all America inscribes upon that honor roll in letters of brightest light,

THOMAS ALVA EDISON.

It is something for all of us to say that we live in the same generation with Edison.

It is an honor to take the hand of this man of master mind and transcendent genius.

No man on kingly throne will be longer remembered than he.

And how has he done so much in his peaceful way to bless the world?

Only by working and working and working all the time, days and nights, and at some periods that he made into a day of four days long, scarcely eating and sleeping for ninety-six hours on a stretch.

How he ever did it is the wonder of the age, since it was all done so quickly, confidently and surely.

How could we ever have gotten on without him?

Our best salutations to you, Thomas A. Edison, the world's helper. Long may you live to enjoy the never setting sun of your well earned fame.

We may say that the birthday of Mr. Edison was marked by a general flag raising in West Orange. The Mayor issued a proclamation asking the citizens of the town and of Essex County to display flags in observance of the day.

Mr. and Mrs. Edison, with their two sons, were away at the time, as they went by automobile to Detroit, Mich., where they were the guests of Henry Ford, the automobile manufacturer.

ARTISTIC WINDOW HANGERS.

The Victor Talking Machine Co. sent out several unusually artistic window hangers to its trade the past fortnight, devoted to the special Vernon Castle supplement featuring the fox trot and Castle Polka. One of these new dances, termed the "Castle Gavotte," was introduced in 1,400 newspapers throughout the country on October 20, 21, 23, by the Ladies' Home Journal, and this unusual publicity naturally created a remarkable demand for the records suitable for this dance. The "Castle Gavotte" is proving remarkably popular with society from coast to coast, and the handsome hangers sent out by the Victor Co. to its trade will act as a stimulant for the creation of dance record business.

LOOK FOR BIG HOLIDAY BUSINESS ON PACIFIC COAST.

Talking Machine Dealers and Jobbers Optimistic—Little Shortage of Stock Reported Outside of Edison Discs—Victor Goods Via Panama Canal—Sonora Phonograph Co. Incorporated—Clark Wise Expansion—Geo. W. Lyle a Visitor—The New Edison Shop.

(Special to The Talking Machine World.)

SAN FRANCISCO, CAL., October 30.—Preparations for the approaching holiday season have demanded the attention of the local trade the past month, and from all indications dealers all along the Pacific Coast anticipate as good business for the rest of this year as they enjoyed during the corresponding period of last year, which in many instances was the best they had ever cared for. There is but little talk of shortage of stocks here this fall, except in the case of the Edison disc. Some new distributors of that product say they will be unable to fill their orders, but most of the other handlers do not anticipate difficulty in that respect this year, which is a great satisfaction in view of former experiences. Retail business in both machines and records is fully up to normal at present, and the higher priced products are in better demand than for some time.

Geo. W. Lyle Visits Columbia Co. Branches.

The local trade received a visit during October from Geo. W. Lyle, general manager of the Columbia Phonograph Co., who was making his annual tour of inspection of the company's Western interests. He was met in Spokane, Wash., by Walter S. Gray, Pacific Coast manager, who makes his headquarters at the San Francisco distributing depot, and they came down the coast together. After spending a few days in this city they left for the southern part of the State by automobile. They parted at Los Angeles on the 22d, Mr. Lyle proceeding homeward, via Salt Lake, Denver and Kansas City, and Mr. Gray coming back here a few days later. When here Mr. Lyle expressed great satisfaction over the condition of business as he found it at his company's branches in the Northwest and in this city. While in Portland, Ore., he closed a deal with the Carman Manufacturing Co., of that city, to make some cabinets for the Columbia concern, with a view of having all cabinets for the trade in the Northwest made at that point if the work compares favorably with the products of Eastern manufacture.

Victor Goods Arrive Via Panama Canal.

Andrew G. McCarthy, of Sherman, Clay & Co., who devotes particular attention to the Victor part of the business, is much encouraged over the way business has picked up in the last two or three weeks. He is now fairly sure of establishing a new record in his department again this year. If he succeeds in showing an increase over last year, it will mean that each year the company has handled

Victor goods, a gain has been made over the preceding year. A large shipment of talking machines arrived recently through the Panama Canal, and the company announces that this means of transportation will be used quite extensively by them from now on.

Sonora Phonograph Co. Incorporated.

The Sonora Phonograph Co. has been incorporated in California, with a capital stock of \$75,000. The directors are Frank M. Steers, E. B. Folsom, F. Moulin, C. H. and J. B. Coffey. The place of business is at San Francisco, where quarters have been fitted up on the second floor of the Phelan building, under the management of F. B. Travers. As the name of the new concern implies, the company will handle the products of the Sonora Phonograph Corp., of New York. The different styles of Sonora machines are on display at the local warerooms, and both a retail and wholesale business will be done from this point. The line is practically new here.

Dealers Stocking Up for the Holidays.

Wholesale Manager F. R. Anglemeier, of the local Columbia branch, says his department experienced quite a rush in the last two or three weeks in filling orders from dealers in the country districts, who are now stocking up for the holidays. Dance records are again in big demand, as social functions are being resumed for the winter.

Increasing Demand for Edison Products.

Business in Edison products has been fine the past month, according to A. R. Pommer, proprietor of the Pacific Phonograph Co., which handles this line exclusively. He says there will be more trouble getting goods than selling them the rest of the year. He has been receiving very good reports from the travelers. J. E. McCracken covered the southern part of the State early in the month, and is now in the northwest. E. C. Howard, who gives full attention to the establishment of new agencies for the Edison disc product, is calling on the trade in the vicinity of Portland.

More Space for Clark Wise & Co. Department.

Alterations are in progress at the store of Clark Wise & Co. whereby the talking machine department will gain considerable more space and better facilities. The mezzanine floor is being extended several feet toward the front of the store and the offices will be moved upstairs, leaving practically the entire ground floor for the demonstration and sale of talking machines. The front of the room will be used for general display purposes, with a

stairway leading up to the offices and piano department. The space under the new offices is being fitted up for a reception room and behind it will be installed seven sound-proof demonstration rooms. The Victor, Columbia and Edison lines are handled by this company, and all will benefit by the store improvements.

Higher Class Records in Demand.

P. H. Beck, who operates the talking machine department on the mezzanine floor of the Kohler & Chase building, anticipates an excellent holiday trade. He says business this fall has been running way ahead of the corresponding period of last year. The demand for Red Seal records is a prominent factor of the business since the opening of the concert season, during which a number of Victor artists will appear here.

To Feature Talking Machines More Extensively.

J. T. Bowers & Son have arranged to feature their talking machine department more extensively. To this end they have engaged J. H. Burnett, formerly with the Graves Music Co., in Portland, to take charge of that part of the business. The Bowers company is one of the pioneers in the piano business here, but it was only recently that it added phonographs to its stock, taking on the Edison disc line exclusively.

Clarence Anrys to Be Married.

Clarence Anrys, son of Frank Anrys, general manager of the Wiley B. Allen Co., will be married on November 7 to Miss Evelyn Godeau, of this city. The groom-elect has been connected with the talking machine department since he became identified with the Allen Co. last year.

Placing Victors in the Schools.

C. E. Edwards and F. P. Corcoran, of the Wiley B. Allen talking machine department, have been conducting an active campaign for Victor talking machines in schools, and the former has just closed a nice contract with the schools of Richmond, Cal., and the latter has been successful in placing several Victrolas in the schools of Goldfield, Nev.

New Edison Shop Attracts Much Attention.

The new Edison Shop on Geary street is proving one of the centers of attraction for this city's music lovers. The store has only been open a few weeks, but in this short while has gained for itself an enviable position. A feature of the establishment is its perfectly harmonious appointments, which have been gained through the detailed perfection of its furnishings and decorations. A handsome concert hall has been fitted up on the mezzanine floor and the daily concerts have attracted many visitors to the store.

H. P. Rothermel, manager of the talking machine department of Eilers Music House, says the principal feature of that business the past month has been the increased demand for higher-priced machines. He is stocking up for a big holiday trade.

Service Is the Paramount Asset of a Victor Distributor

The factory controls the Prices and Terms.

The distributor controls his Service.

This is the reason we have endeavored to make

EASTERN SERVICE THE BEST EVER

And we believe we have succeeded, and will convince you if you will give us the opportunity. A trial order will do.

Will you do it?

Thank you.

When may we expect it?

EASTERN TALKING MACHINE COMPANY

177 TREMONT STREET, BOSTON, MASS.

EDISON

FOR NINETEEN YEARS TALKING MACHINES EXCLUSIVELY

VICTOR

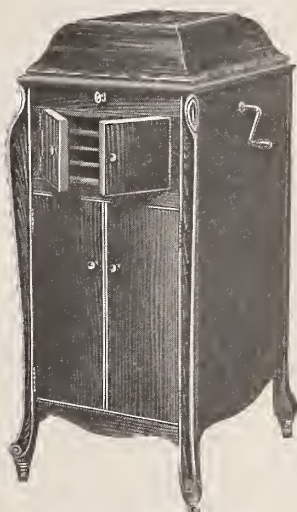

Victrola XI, \$100
Mahogany or oak

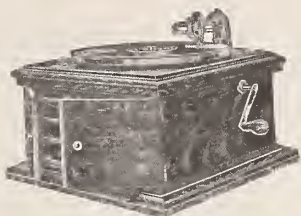

Victrola VI, \$25
Oak

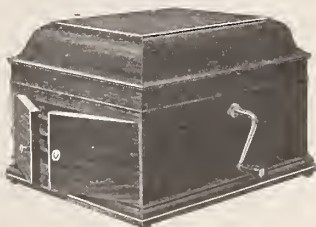

Victrola IX, \$50
Mahogany or oak



Victrola XVI, \$200
Mahogany or oak

“Will there be a Victrola in your home this Christmas?”

This important question will confront the people of the whole country right on until Christmas.

It is the key-note of our nation-wide holiday advertising campaign, and its force will send thousands of customers into the stores of Victor dealers everywhere.

It will help to make this the biggest holiday season you ever had—even ahead of the phenomenal business of last Christmas.

Victor Talking Machine Co., Camden, N. J., U. S. A.

Berliner Gramophone Co., Montreal, Canadian Distributors.

Always use Victor Machines with Victor Records and Victor Needles—the combination. There is no other way to get the unequalled Victor tone.



Victor Distributors

Albany, N. Y. Finch & Hahn.
 Altoona, Pa. W. F. Frederick Piano Co.
 Atlanta, Ga. Elyea-Austell Co.
 Phillips & Crew Co.
 Austin, Tex. The Talking Machine Co., of Texas.
 Baltimore, Md. Cohen & Hughes, Inc.
 E. F. Droop & Sons Co.
 H. R. Eisenbrandt Sons.
 Bangor, Me. Andrews Music House Co.
 Birmingham, Ala. Talking Machine Co.
 Boston, Mass. Oliver Ditson Co.
 The Eastern Talking Machine Co.
 M. Steinert & Sons Co.
 Brooklyn, N. Y. American Talking Machine Co.
 Buffalo, N. Y. W. D. Andrews.
 Neal, Clark & Neal Co.
 Burlington, Vt. American Phonograph Co.
 Butte, Mont. Orton Brothers.
 Chicago, Ill. Lyon & Healy.
 The Talking Machine Co.
 The Rudolph Wurlitzer Co.
 Cincinnati, O. The Rudolph Wurlitzer Co.
 Cleveland, O. The W. H. Buescher & Sons Co.
 The Collister & Sayle Co.
 The Eclipse Musical Co.
 Columbus, O. Perry B. Whitsit Co.
 Dallas, Tex. Sanger Bros.
 Denver, Colo. The Hext Music Co.
 The Knight-Campbell Music Co.
 Des Moines, Ia. Chase & West Talking Mach. Co.
 Mickel Bros. Co.

Detroit, Mich. Grinnell Bros.
 Elmira, N. Y. Elmira Arms Co.
 El Paso, Tex. W. G. Walz Co.
 Galveston, Texas. Thos. Goggan & Bro
 Honolulu, T. H. Bergstrom Music Co., Ltd.
 Indianapolis, Ind. Stewart Talking Machine Co.
 Jacksonville, Fla. Florida Talking Machine Co.
 Kansas City, Mo. J. W. Jenkins Sons Music Co.
 Schmelzer Arms Co.
 Lincoln, Neb. Ross P. Curtice Co.
 Little Rock, Ark. O. K. Houck Piano Co.
 Los Angeles, Cal. Sherman, Clay & Co.
 Louisville, Ky. Montenegro-Riehm Music Co.
 Memphis, Tenn. O. K. Houck Piano Co.
 Milwaukee, Wis. Badger Talking Machine Co.
 Mobile, Ala. Wm. H. Reynolds.
 Montreal, Can. Berliner Gramophone Co., Ltd.
 Nashville, Tenn. O. K. Houck Piano Co.
 Newark, N. J. Price Talking Machine Co.
 New Haven, Conn. Henry Horton.
 New Orleans, La. Philip Werlein, Ltd.
 New York, N. Y. Blackman Talking Machine Co.
 Emanuel Blout.
 C. Bruno & Son, Inc.
 I. Davega, Jr., Inc.
 S. B. Davega Co.
 Chas. H. Ditson & Co.
 Landay Brothers, Inc.
 New York Talking Machine Co.
 Ormes, Inc.
 Silas E. Pearsall Co.
 Benj. Switky.

Omaha, Neb. Nebraska Cycle Co.
 A. Hospe Company.
 Peoria, Ill. Putnam-Page Co., Inc.
 Philadelphia, Pa. Louis Buehn.
 C. J. Heppie & Son.
 Penn Phonograph Co., Inc.
 The Talking Machine Co.
 H. A. Weymann & Son, Inc.
 Pittsburgh, Pa. C. C. Mellor Co., Ltd.
 Standard Talking Machine Co.
 Portland, Me. Cressey & Allen, Inc.
 Portland, Ore. Sherman, Clay & Co.
 Richmond, Va. The Corley Co., Inc.
 W. D. Moses & Co.
 Rochester, N. Y. E. J. Chapman.
 The Talking Machine Co.
 Salt Lake City, U. Consolidated Music Co.
 San Antonio, Tex. Thos. Goggan & Bros.
 San Francisco, Cal. Sherman, Clay & Co.
 Savannah, Ga. Phillips & Crew Co.
 Seattle, Wash. Sherman, Clay & Co.
 Sioux Falls, S. D. Talking Machine Exchange.
 Spokane, Wash. Sherman, Clay & Co.
 St. Louis, Mo. Koerber-Brenner Music Co.
 St. Paul, Minn. W. J. Dyer & Bro.
 Syracuse, N. Y. W. D. Andrews Co.
 Toledo, O. The Whitney & Currier Co.
 Washington, D. C. Robert C. Rogers Co.
 E. F. Droop & Sons.

FAMOUS RECORD ALBUMS

AT VERY LOW PRICES TO MEET COMPETITION

These Record Albums will Pay for Themselves in a short Time by Preserving Records. When Full the Albums are Flat and Even Like Books. They will Fit in a Library Cabinet or Book Case, or They will Lie Flat on One Another.

We manufacture Disc Record Albums containing 12 pockets to fit the new Victrola Cabinets No. X. and XI.

We also make Albums containing 17 pockets, and with the indexes these Albums make a complete system for filing all disc Records.

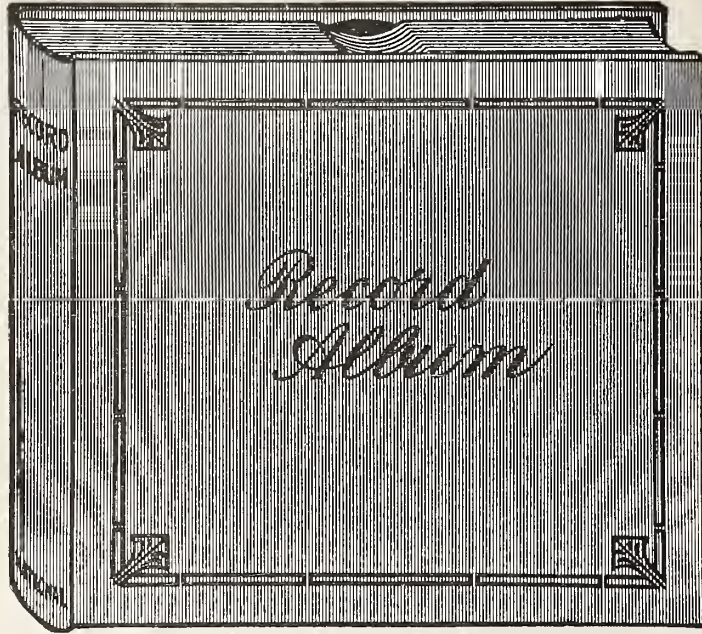

For Durability, Artistic Design and Finish, our Albums have no equal. They are made in the most substantial manner by skilled workman. We sell our Superb Albums at big discounts to meet competition. Shall we send samples and quote our very low prices?

THESE ALBUMS ARE THE BEST FOR VICTOR, EDISON, COLUMBIA AND ALL OTHER DISC RECORDS

Write for samples of our Albums, which are superior to all others

Address **NATIONAL PUBLISHING CO., 235 South American St., Philadelphia, Pa.**

TRADE CONDITIONS IN CINCINNATI.

Dealers Look for a Large Holiday Business—Phonograph Co. in Its New Quarters—Columbia Activity Reported by Manager Whelen—Wurlitzer Ready to Double Christmas Business—Dealers Are Stocking Up.

(Special to The Talking Machine World.)

CINCINNATI, O., November 8.—Local conditions are fairly satisfactory. Most of the business just now is confined to record buyers, but the merchants believe the holiday shopper will soon be in the field and are making arrangements accordingly. More attention is being given to window display work, and any kind of an event which would help sales is tackled by the merchants in decorating his display space.

The Phonograph Co. is now domiciled in its new quarters in the Globe Wernicke building on Fourth street, the change being made last week. The company has decidedly better quarters from a jobbing standpoint, the new space being more concentrated and better suited for wholesale selling purposes as compared with the Main street store.

The Aeolian Co. is now concentrating its advertising campaign on the Columbia line. The change took place during the past month. The company, however, continues to make a specialty of Victor records.

The John Shillito Co.'s music department has not yet made any selection relative to a line of phonographic goods. The matter has been pending some weeks, and it is probable that the approach of the holiday season will hasten a decision.

One of the interesting visitors of last week was Harry Meeks, of the Cheney Talking Machine Co., Chicago, who is a former Cincinnati, having at one time been connected with the local stores of the Rudolph Wurlitzer Co. and the Columbia Phonograph Co.

Manager Whelen, of the local Columbia store, seems to be very optimistic about the general con-

dition. In talking to The World representative he said: "There is no doubt but that the war is affecting business, but we have gotten our share of whatever business there is, and we closed the month with an increase over last October. This shows that the Columbia is getting on top and makes me wonder what we would have done if there had been no war. The first part of this month has shown a substantial increase in business and, despite conditions, I look for a large holiday business.

"This condition seems to be prevalent among the dealers, as they are ordering heavy and even at this stage of the game we are having a hard time to get sufficient stock to supply the demand. The new 'Leader' and 'Mignonette,' with the exclusive push button interior, is creating quite a 'stir' in the talking machine circles and bids fair to be a great 'seller.'"

The Rudolph Wurlitzer Co. is getting ready to tackle the Christmas business with better facilities than last year, when the supply was exhausted, causing the department to turn many buyers away. The company is doing some interesting local advertising in favor of the Victor machines.

The Otto Grau Piano Co.'s department is past the infancy stage and is now one of the features of the business of this house.

JOINS THE SHEPARD CO.

John H. Massey, a well-known talking machine man of Providence, R. I., and who for a number of years was manager of the phonograph department of the J. A. Foster Co., has resigned and become associated as special representative of the talking machine store of the Shepard Co., dealers in Edison diamond disc phonographs, Victor-Victrolas and Columbia Grafonolas.

Good ideas often occur simultaneously to several people, but only one of them is first to "put it across."

FEATURES OF "BROTHER FANS."

Columbia Grafonola with Special Record and a Pathoscope Used with Excellent Effect in Tom Lewis' New Vaudeville Act.

In his new vaudeville act, "Brother Fans," now being presented, at the prominent vaudeville theaters in the East, Tom Lewis makes use of both a Columbia Grafonola and a Pathoscope outfit to excellent advantage. The occasion is when the Giants and White Sox were on their tour of the world and has reached London. Tom Lewis, in the role of a rabid baseball fan marooned in England, sees the game played there, meets two other strong "fans" and invites them to his rooms for dinner. In order to give proper atmosphere to the dinner party there is started on the Grafonola a record which reproduces perfectly the jumble of sounds at the opening of a ball game, with the announcements of the batteries, the cries of the peanut and pop vendors and the cheering at the first hit. While the record is playing the Pathoscope throws on a section of the wall several animated scenes at a ball game supposed to be registered simply in the minds of the three fans who are thinking of home. The idea is excellent and arouses considerable enthusiasm on the part of the audience.

W. G. Britton, formerly credit manager of the wholesale headquarters of the Columbia Graphophone Co., 89 Chambers street, New York, has been promoted to the assistant managership of the establishment, succeeding George A. Baker, who has become manager of the company's Baltimore, Md., branch. Kenneth M. Johns, formerly manager of the Detroit branch of the Columbia Co., has joined the staff at 89 Chambers street, New York, as credit manager. R. F. Bolton is manager of this wholesale branch.

It's the man who hasn't learned how to swim for himself who gets drowned in the swamping seas of business disaster.

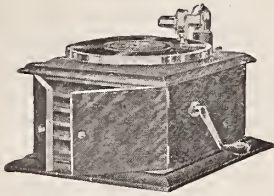

Victrola IV, \$15
Oak



Victrola VI, \$25
Oak

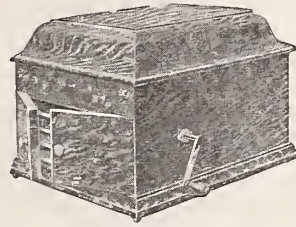

Victrola VIII, \$40
Oak

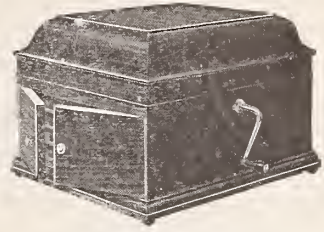

Victrola IX, \$50
Mahogany or oak

“Will there be a Victrola in your home this Christmas?”



That is the question being put before the entire country in the extensive Victor advertising.

That is the question which is going to be settled in thousands of homes—and settled to your satisfaction.

That is the question which will help to make a new high record for Victor Christmas business.

So don't lose sight of the value to you of the Victor holiday advertising and “Will there be a Victrola in your home this Christmas?”

Victor Talking Machine Co.

Camden, N. J., U. S. A.

Berliner Gramophone Co., Montreal, Canadian Distributors.

Always use Victor Machines with Victor Records and Victor Needles—the combination. There is no other way to get the unequalled Victor tone.

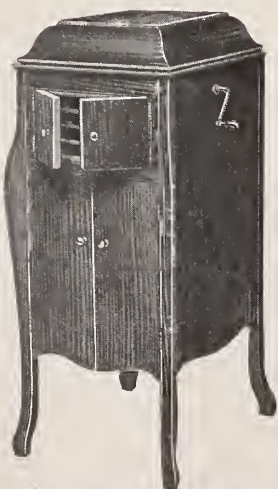

Victrola X, \$75
Mahogany or oak

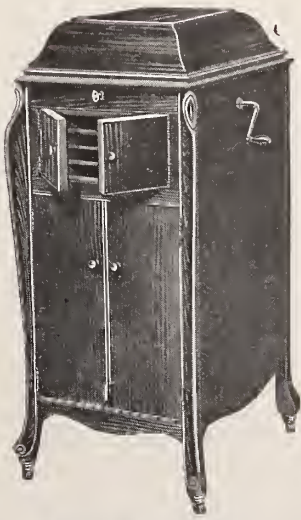

Victrola XI, \$100
Mahogany or oak

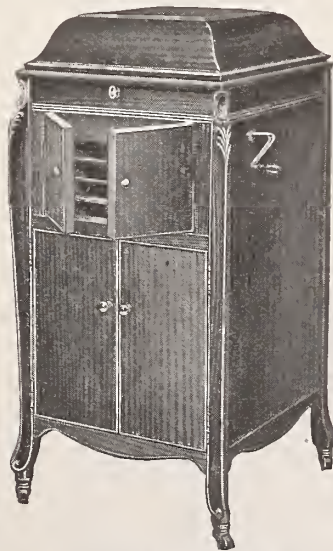

Victrola XIV, \$150
Mahogany or oak



Victrola XVI, \$200
Mahogany or oak



The *long wear* of Columbia Double-Disc Records is a feature that printed words hardly convey. But in practice there is no mistaking it. It is a feature that is peculiarly Columbia, and once a record buyer realizes it, he is *solid*.



(Write for "Music Money," a book "full of meat" for those dealers interested in quick and frequent turnover of capital.)

**Columbia Graphophone Company
Woolworth Building, New York**

DISCUSSES EUROPEAN CONDITIONS.

John A. B. Cromelin, Manager of European Interests of Columbia Graphophone Co., Visiting Headquarters — Declares Business in England Is Active Despite War—Great Demand for Patriotic Records.

"Notwithstanding the present European war, our sales have kept up wonderfully," said John A. B. Cromelin, manager of the European interests of the Columbia Graphophone Co., with headquarters in London, who arrived here a fortnight ago for a short visit. "Surprising as it may seem, our September turnover in Great Britain equaled that of September of last year, and our general European business for September actually showed a larger profit than that of the corresponding month of 1913. These excellent sales totals have surprised the members of our own organization, and indicate the strides that our products are making on the other side of the Atlantic.

"When I left London our factory was running a night shift, and even then was unable to keep up with the orders on hand. We are planning an increase of manufacturing facilities in the near future in order to give our dealers perfect service and co-operation. Columbia business in Italy is gaining steadily, thanks to an efficient sales organization and the merits of Columbia machines and records.

"The recent supplements of patriotic records which we issued abroad are proving a tremendous success, and it is indeed a problem to keep up with the demand for this class of music. We have experienced absolutely no difficulty in securing the necessary raw material to manufacture our products, as we contracted for the most important

material in large quantities many months ago.

"With the close of this war I believe that the Columbia Graphophone Co. will occupy a still stronger position in European and British talking machine circles than it now does. The general outlook for the future of the industry furnishes the basis for this prediction, and I may say that we are strengthening and perfecting our sales organization with this object in view. We have but recently erected a building for the assembling of special machinery and a large storage department, and are now making plans for the handling of a much larger machine business than in the past."

NO LULL IN BALTIMORE TRADE.

Indications of a Heavy Holiday Trade—New Addition to E. F. Droop & Sons' Store Proves Convenience—What Local Houses Report.

(Special to The Talking Machine World.)

BALTIMORE, MD., November 3.—The talking machine industry shows no slackening up at this time, and the indications are that between now and the holidays some nice records in the way of sales will be made. All of the dealers report progress, and judging from the activities in the various stores it would seem that such claims of the dealers are well founded.

Joseph Fink, of the Fink Talking Machine Co., announces that he is kept on the run by the extensive business done at the main store and the branch store, which has only been in operation about two months. This firm handles both the Victor and Columbia lines.

H. R. Eisenbrandt Sons continue to have very satisfactory demands for the Victor line of instruments and calls for the latest records.

E. F. Droop & Sons Co. find that the new addition to their store has proved a most desirable as well as necessary adjunct in order to handle the increasing business. This company is having a remarkable call for the Victor and Edison machines, while the sale of records has taken a large jump. Manager W. C. Roberts and his force are kept on the go steadily, and are anticipating the breaking of previous records.

Manager S. A. Dennison, of the local branch of the Columbia Graphophone Co., finds it easy to put up encouraging reports on his slate each week. He reports very good results with the Columbia line for the month, and is still looking forward to making the best mark next month that he has made at any time since being located in the Monumental City.

Gomprecht & Benesch, through Manager Holmes, announce a very satisfactory month with the Victor line.

BAGSHAW'S EXPANDING BUSINESS.

W. H. Bagshaw, Lowell, Mass., to whom is credited being the first manufacturer of talking machine needles, reports a good, strong demand for its various styles of talking machine needles, coming not from any one section of the country, but from all over the Western Hemisphere and various foreign countries. Quality is the lever upon which these sales have been made, and it is this policy, under the direction of C. H. Bagshaw, general manager of the firm, that is responsible for the constant patronage which the house enjoys. The outlook for the next few months, particularly, is reported to be excellent from the business standpoint.

The DITSON Pledge

is to see that our clientele has a better service than ever—setting a new standard in Victor jobbing deliveries. The demands of alert Victor dealers—the kind that grow—are many and varied, and we furnish the "first-aid" in every instance.

We believe this year's Victor business will be of tremendous proportions, and it will pay you to have

The Fastest Victor Service

which is a requisite in this hustling age. We possess the largest stocks, the best organization and most up-to-date equipment in the Eastern half of the country.

This covers Victor machines, records and supplies of every kind.

Will you let us tell you more about Ditson co-operation? A postal gets this information!

OLIVER DITSON CO., Boston, Mass.

THE NEW EDISON SHOP A VERITABLE TEMPLE OF MUSIC

Beautiful New Building Opened by the Phonograph Corporation of Manhattan, Opposite the Public Library, Devoted to the Sale and Exploitation of the Edison Diamond Disc Phonograph—Most Artistically Arranged—New Structure Wins Praise of Public.

One of the events of the local talking machine trade the past month was the formal opening by the Phonograph Corporation of Manhattan of its new and beautiful Edison Shop, at 473 Fifth avenue, New York, directly facing the New York Public Library, between Fortieth and Forty-first streets. This new temple of music is devoted to the demonstration of the new and recently perfected Edison disc diamond phonograph, and every detail of its construction and decoration is in accord with the prestige that these products have already attained with the trade and music lovers.

The new Edison Shop is four floors in height, of imposing architectural design, and fully equipped throughout with every convenience and comfort for the proper display of the instruments and records. The exterior presents a front both impressive and attractive, an arch of granite terra cotta with an insert of panel of cream and gold, finished in strong color in relief.

Entering the first floor one comes to a large general reception room, shown in one of the illustrations herewith, which is worthy of note because

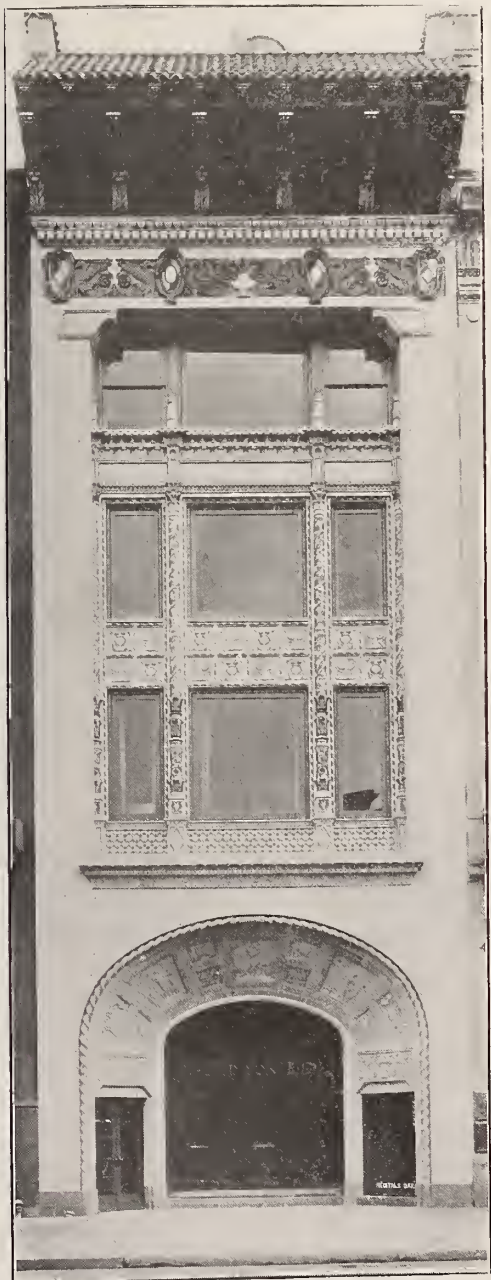

Entrance to Edison Shop.

of its artistic furnishing and equipment. Here on display are many of the new styles of the perfect Edison diamond disc phonograph. A feature of this room is the fact that it is finished in American walnut, and supplied with furniture specially designed for it. In the rear of the first floor is the concert chamber, or music room, in which daily recitals are given from 10 a. m. till 5.30 p. m., with

special programs. The walls of the music room are of Travertine stone, embellished with four sculp-



General Reception Room on the Street Floor of the Edison Shop—Leads Into Concert Hall.

tered panels representing classical musical groups surmounted by a domed Byzantine ceiling. In this room, as throughout the building, special attention has been paid to acoustics, sound proof walls, special lighting and ventilating features and every contrivance for the production of perfect harmony in furnishings as well as in arch tecture.

On the second floor is the record room, where arrangements have been provided for the filing and keeping of records in large number. Opening from the record room are the sound-proof booths for the hearing and testing of records. Here one may have tested with absolute fidelity any record of solo, opera, concert, and listed to a perfect reproduction in every detail. All makes of records can be made to play on the new Edison. On the third floor are the executive offices, with spacious foyer, rest rooms and three machine demonstration rooms—one in mahogany, one in Colonial and one in American walnut.

Throughout the building rare taste and judgment have been exercised to the end that music lovers may find ease and comfort. All draperies and hangings are specially woven by masters of their craft, and all panels and decorations are of a character to blend and harmonize. It might be men-

tioned that rugs of special design had been ordered from Austria, and will be shipped as soon as the war ceases.

The new Edison Shop has been the subject of splendid advertising the past fortnight, and as a result, the warerooms have been thronged with interested visitors from many far distant points. One and all have been enthusiastic in their praises of the Edison diamond disc phonograph and disc

records, and the sales closed to date in the new establishment have exceeded all expectations.

The sales organization at the Edison Shop is a most efficient one, with G. L. Babson, of the Phonograph Corporation of Manhattan as general manager. L. S. McCormick is manager of the ware-rooms, assisted by a competent staff of sales people.



The Palatial Concert Hall Where Recitals Are Given Daily.

NOTE THE NEW ADDRESS:
CARLISLE BUILDING, 19-25 E. 24th ST., NEW YORK, N. Y.

ONLY 40 DAYS TO CHRISTMAS

Order Holiday Records NOW

We Have the Goods

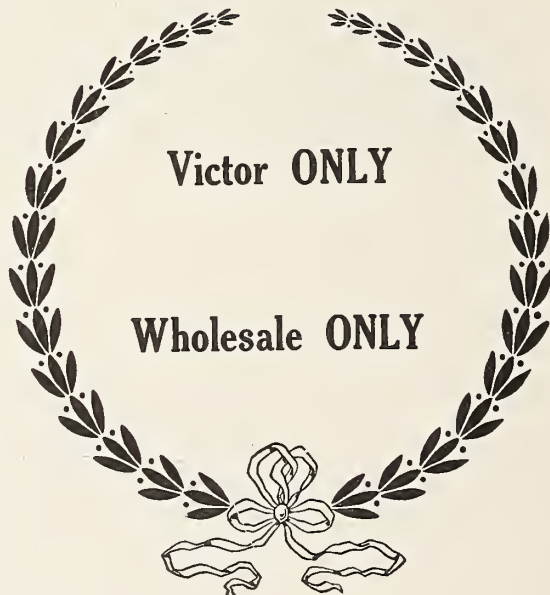

You want quick delivery—and get it!
Nothing held back. You get the last machine or record.
The sample in the showroom is **YOURS**.

*We sell wholesale ONLY, and handle nothing besides
Victor Talking Machines, Records, and Supplies!*

BENJ. SWITKY - - VICTOR SPECIALIST

CARLISLE BUILDING, 19-25 E. 24th STREET, NEW YORK, N. Y.

Telephone Madison Square 7531-7532.

EDISON ATTENDS OPENING OF DETROIT EDISON SHOP.

Distinguished Inventor Compliments Max Strasburg on the Opening of the New Edison Shop on October 27—New Quarters for Metzger Co.—Victrola for Goodrich Rubber Co.—Ling's New Talking Machine Department—October Trade Ahead of Last Year.

(Special to The Talking Machine World.)

DETROIT, MICH., November 9.—Detroit has a new and elegant talking machine store, "The Edison Shop," opened Tuesday, October 27. Thomas A. Edison himself was present on opening day, and presented the new store with a large fern, which now graces the show window, with Mr. Edison's personal card conspicuously attached.

Mr. Edison had been in the city for a week, visiting Henry Ford, the automobile king, and on the day before his departure, accompanied by Mr. Ford, he called at the establishment bearing his name, to pay his compliments to his managers, Wallace and Harry Brown.

The Edison Shop is located at 31 Grand River avenue east, separated by only one store from the Victrola Shop, of which Max Strasburg is manager. Mr. Strasburg says he welcomes the neighboring competition,

for it will bring more people in that direction seeking talking machines, and while he doesn't expect to land all the sales, he undoubtedly will benefit by the increased travel in that direction. Incidentally, by the time this is in print, J. Henry Ling will have opened his new talking machine department at the southeast corner of Grand River and Library avenues, thereby giving the Edison, Victor and Columbia fine stores within a hundred feet of each other. That corner surely is the talking machine colony of Detroit.

The Messrs. Brown are new to the talking machine trade, but not new to the business world. They are cousins, who had attained responsible positions in large commercial establishments, and desiring to go into business for themselves, organized a corporation and selected the talking machine business as about as likely looking a venture as they could find.

"It surely is handling the Edison," remarked Wallace Brown, to The Talking Machine World representative. "All we have to do to sell these

machines is just to play a few records on them."

The Edison Shop has demonstrated that it is a live wire by opening its bid for public favor with liberal advertising. And it is getting results, for half a dozen prospects were there at the time The World correspondent dropped in. The Brown Sales Co. is the corporate name of the establishment, but The Edison Shop is the name by which it is known.

The store is somewhat different from the other



Interior of New Edison Shop, Detroit.

talking machine stores of Detroit, in furnishings and fittings. The demonstrating rooms, instead of being of white enamel, are of mahogany, the upper half of the partitions being of plate glass. The floors are covered with rich carpets and rugs. The offices are at the rear, but in front are a desk and phone, maintained solely for the convenience of patrons. Ink, note paper and pens are at hand. The stock, of course, includes a full line of elegantly finished instruments. At present three clerks are employed, besides the Browns.

Upper Woodward avenue will have a new talking machine store early in the coming year, or rather, an old established store will remove to new and specially prepared quarters. The W. E. Metzger Co. began handling the Victor line eight years ago, at 252 Woodward avenue. Five years ago the company removed to more spacious quarters at 351 Woodward, above Grand Circus Park. Business expansion now demands still more commodious accommodations, and the company is having constructed for its special needs a terra cotta build-

ing at 501-503 Woodward, where demonstrating rooms, record racks and stock of the most up-to-date nature will be installed. The company expects to take possession about February 1. As the lease on the present quarters does not expire until May 1 both store will be operated until that time.

Joseph Adcock, the manager, this week sold a \$200 Victrola outfit to Bert Morehead, manager of the Detroit branch of the Goodrich Rubber Co. The Metzger trade ranges in the high-priced goods, most of the sales being of machines costing from \$100 to \$200. The new store will be so arranged that additional space can be given to the talking machines as increase of business demands it.

J. Henry Ling, in fitting up his talking machine department, will venture a unique innovation. Two of the demonstrating rooms are to be interior ones, where not much daylight will be available, and electric illumination will be necessary. These rooms are to be made "moonlight rooms," draped on the sides and top with dark blue cloth, spangled with golden stars, and in an appropriate place in the "zenith," a rising moon, lighted with an electric glow. Though there will be two rooms, the one moon will illuminate both, for the only partition will be plate glass. The new department will be opened some time between November 15 and Thanksgiving Day. As a piano establishment the House of Ling is the oldest in Detroit. Mr. Ling has had such a strong inquiry for talking machines in the last year or two that he decided it was time to begin handling them himself, instead of directing his patrons to other stores. The Columbia is his leader.

A significant indication of the volume of talking machine business in Detroit is the fact that the Max Strasburg Co. has just purchased a Ford auto delivery car to be used solely for the delivery of records. This step was found necessary because the business grew to be too heavy for the large auto delivery car to handle. The Strasburg Co. is putting up new and elegant signs, arranged so that they can be read from five streets.

October talking machine business in Detroit was about 30 per cent. ahead of October, 1913, and the outlook is for the greatest holiday trade ever. In fact, holiday trade already has commenced, the advertising now being of the Christmas tenor. All the stores are well stocked up and expect to be able to handle the rush better than ever before. Neither the war nor the alleged business depression seem to have any effect in depressing the "talkers."

Among the new accounts opened by the Columbia Co.'s local wholesale headquarters the past month were J. Henry Williams, Cohoes, N. Y., and H. E. Hemenway, Granville, N. Y. Both of these new dealers have placed substantial initial orders to inaugurate their campaign.

Established 1889

Good Men: are always needed.

Write us for a dealership proposition on the

Edison Diamond Disc Instrument

Frank E. Bolway & Son

325 West Fayette Street
SYRACUSE, N. Y.

32-34 W. Bridge Street
OSWEGO, N. Y.



LOUIS XVI
 Model A450, Circassian
 Walnut, \$450.00
 Model A400, Mahogany,
 \$400.00



SHERATON
 Model A275, Ma-
 hogany, Inlaid
 Plain, \$275.00

Think About Your Different Kinds Of Customers As Well As Your Line

Look at the goods you carry through other people's eyes.
 Don't try to fit your customer to your line.
 Sell the line that fits *all* your customers.

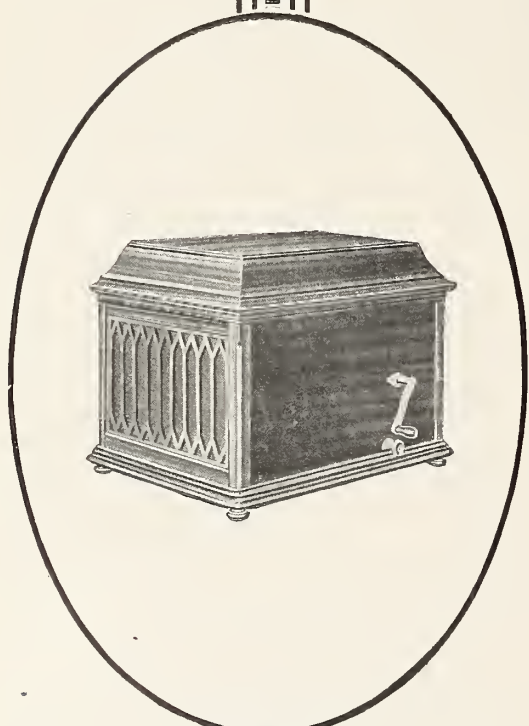

Edison Phonographs **DIAMOND DISC** and **AMBEROLAS**

give you all the different kinds of phonographs which you need for all your different customers. They give your customers so unequalled a variety in Types, Models, Designs and Prices that their choice can never hesitate between the Edison and some *other* phonograph—it concentrates instantly on the Edison Line because its very size tells them that *somewhere* in that great line is the phonograph that *they* want.

Model A80, Mahogany,
 \$80.00

Thomas A. Edison, Inc.



Model A200, Mahogany
 and Oak, \$200.00



Model A300, Cir-
 cassian Walnut,
 \$300.00



SHERATON
Model A290, Mahogany, Inlaid Marquetry, \$290.00

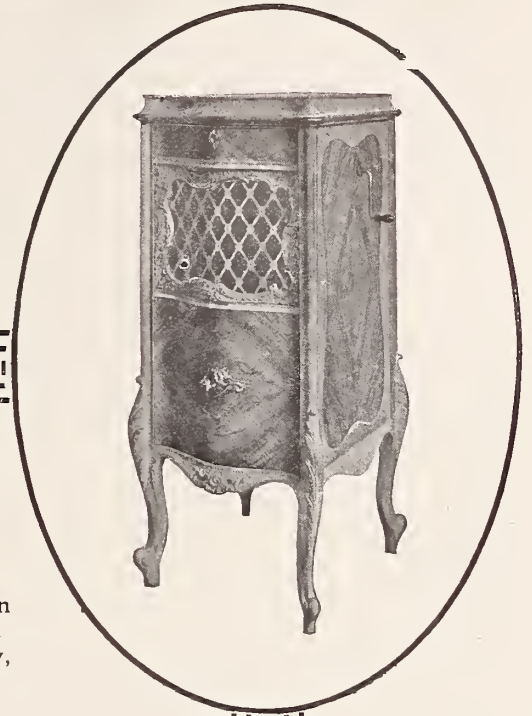

LOUIS XV
Model A425, Circassian Walnut, \$425.00
Model A375, Mahogany, \$375.00

Seven Customers Whom You Can Sell Right Away

These seven will buy Edison Phonographs from you right off the reel—and each one will buy for a different reason. These seven buyers are:

1. The one who wants no bothering with needles.
2. The one who wants *all* the original music, overtones as well as fundamental tones.
3. The one who wants long playing records.
4. The one who wants records that the children won't break.
5. The one who wants steady speed and steady pitch.
6. The one who wants the only phonograph whose tone is suited to outdoors.
7. The one who wants his cabinet to match his indoor furnishings.

If you want each of these seven customers to bring in seven more, and each of those to bring in still another seven, then you want the *full* Edison Line. Get in touch with the nearest jobber. Write us for his name now—to-day.

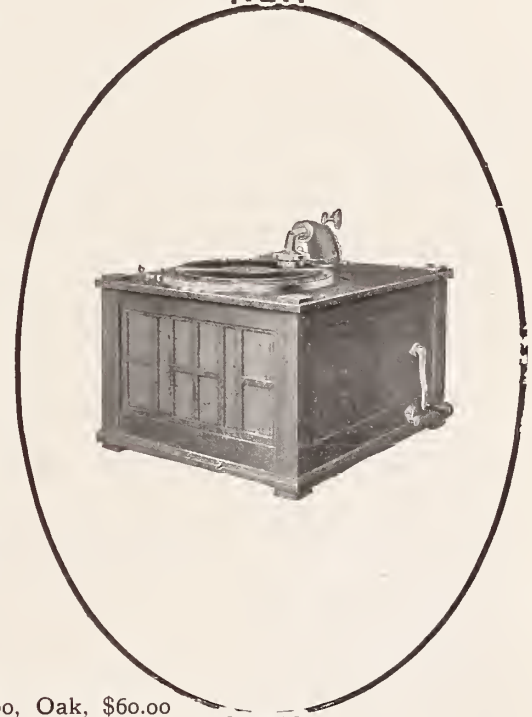

Model B60, Oak, \$60.00

59 Lakeside Ave., Orange, N. J.



Model A250, Mahogany and Oak, \$250.00



Model A150, Mahogany and Oak, \$150.00

The **TALKING**
For the **MACHINE**
makers & **WORLD**
sellers of
talking
machines

EDWARD LYMAN BILL, - - - Editor and Proprietor.

J. B. SPILLANE, Managing Editor.

Trade Representatives: GLAD. HENDERSON, C. CHACE, L. E. BOWERS, B. BRITAIN WILSON,
 A. J. NICKLIN, AUGUST J. TIMPE, L. M. ROBINSON.

Boston: JOHN H. WILSON, 324 Washington Street.

Chicago Office: E. P. VAN HARLINGEN, Consumers' Building, 220 South State Street.
 HENRY S. KINGWILL, Associate. Telephone, Wabash 5774.

London, Eng., Office: 2 Gresham Buildings, Basinghall St. W. LIONEL STURDY, Manager.
 Representatives for Germany and Austria: VERLAG NEC SINIT, Berlin C. 19, Ross-Strasse 6,
 Germany. GEO. ROTHGIESSER, Director.

The Talking Machine World has regular correspondents located in all of the principal cities throughout America.

Published the 15th of every month at 373 Fourth Ave., New York.

SUBSCRIPTION (including postage), United States, Mexico, \$1.00 per Year; Canada, \$1.25; all other countries, \$1.75.

ADVERTISEMENTS: \$3.50 per inch, single column, per insertion. On quarterly or yearly contracts a special discount is allowed. Advertising pages, \$120.00.

REMITTANCES: should be made payable to Edward Lyman Bill by check or Post Office Money Order.

NOTICE TO ADVERTISERS.—Advertising copy should reach this office by the first of each month. By following this rule clients will greatly facilitate work at the publication headquarters.

Long Distance Telephones—Numbers 5982-5983 Madison Sq.
 Cable Address: "Elbill," New York.

NEW YORK, NOVEMBER 15, 1914.

THERE has been considerable misunderstanding existing in various quarters as well as much speculation as to just the effect of the Clayton law upon various lines of manufactured products sold under certain restrictions.

The press reports which were sent broadcast throughout the land at the time the bill became a law, stated that it prohibited the fixing of prices to the retailer.

Not so as we interpret it.

A careful examination of the bill shows that it attempts only to rule against fixed prices in conjunction with the understanding that dealers shall not handle competitive goods where such action tends to create a monopoly.

Talking machine manufacturers and others engaged in lines of trade who believe in maintaining fixed prices have found nothing in their present contractual relations with their dealers which conflicts with the provisions of the law.

This new law aims at lessening a monopoly and talking machine interests are not affected by the new measure.

It was believed that something extremely radical would be incorporated in the recently enacted law which was going to revolutionize conditions in the retail trade. An analysis of the law shows that it is not as radical as was predicted by many. In fact, the measure has been softened so that some of the drastic features which were urged by politicians have not been put through.

The new law, of course, would influence operations in some trades. If we dig into the heart of this new legislation we will find that where it hits the hardest is that there will be an interference with the systems of exclusive agencies and exclusive selling rights, and a ban is placed on the form of agreements and allowances of preferential prices.

Section 2 of the new law is, in full, as follows:

"That it shall be unlawful for any person engaged in commerce, either directly or indirectly, to discriminate in price between different purchasers of commodities, which commodities are sold for use, consumption or resale within the United States or any territory thereof, or the District of Columbia or any insular possession or other place under the jurisdiction of the United States, where the effect of such discrimination may be to substantially lessen competition or tend to create a monopoly in any line of commerce. Provided, that nothing herein contained shall prevent discrimination in price between purchasers of commodities on account of differences in the grade, quality or quantity of the commodity sold, or that makes only due allowance for difference in the cost of selling or transportation, or discrimination in price in the same or different communities made in good faith to meet competition. And

provided further, That nothing herein contained shall prevent persons engaged in selling goods, wares or merchandise in commerce from selecting their own customers in bona fide transactions and not in restraint of trade."

IF we look at this section closely, it might appear that if the measure allowed special prices to the exclusive agent or selling representative in a locality, a strict interpretation of this law may be construed that any exclusive agency would "tend to create a monopoly." But, on the other hand, if products are sold at retail at a standardized price, fixed by the manufacturer, it is a question whether the handling of the line by an exclusive agent would really "substantially lessen competition," as compared with the taking of the line by a number of retail establishments.

We cannot see that the enactment of this new law will affect the sale of talking machines at retail, for, while the jobbers are exclusive in their lines, retail establishments may sell any kind of machines which they care to offer. So our interpretation of the measure is that it will not disturb conditions or contractual relations between manufacturers and dealers in the slightest. It aims obviously at the exclusive agency agreement, and in Section 3 it distinctly states that it shall be unlawful for any person to enter into a contract for the sale of goods of a certain character, with the understanding, or agreement, that the lessee or purchaser shall not deal in merchandise or offer commodities of a competing make. Hence, our version of the effect of the Clayton law on trade is that retail merchants in all lines will not bind themselves to handle any special lines of goods. In other words, the retail stores of the country must be open to all lines of merchandise for which customers ask. In brief, a dealer cannot, under the new law, be prohibited from selling competitive products.

ONE effect, supposedly, of the act is that it will render it impracticable for merchants to sell talking machines, piano players, etc., with any restrictions to the effect that there may not be used in conjunction therewith the records, needles, perforated rolls, or accessories put out by rival firms.

That clears up the situation so that manufacturers of specialties have an open market for their products which can be used in connection with talking machines.

Anyone who has observed the changing conditions in the retail trade throughout America must be convinced that there is a desire on the part of the public to purchase from stores which carry varied lines, and it is up to the merchants to meet that public demand.

We can see no good reason that can be advanced why a man who desires a particular brand of shoes should travel over the whole town to find a store which is the exclusive representative of this particular shoe, and the same rule would apply to all of the manufactured products which enter into our every-day life.

If a man desires a talking machine of a particular brand why should he not be able to purchase it from a regular talking machine store, always, provided, of course, that the dealer deems it good business on his part to carry the line.

The talking machine dealer, like the retailer in any other line, will be guided by his individual views as to what particular goods he should carry. If it is advisable to carry one line of talking machines and records, why then presumably he will so arrange with the jobbers who represent these special lines. He gets back to the best advertised and the best quality products and the men who have built great enterprises will not permit them to die through lack of fertilization.

So, as we view the Clayton law, it does not constitute a menace to the talking machine interests. It would, however, be a very serious one if it struck a blow at price maintenance. We have claimed for many years that price maintenance is the rock on which this trade is founded, and once destroy that foundation and the papers will be filled with standard talking machines advertised at cut rates just the same as they are of pianos and other lines of home accessories.

As a matter of fact, the piano merchants have valued pianos too cheaply. They have not appreciated the product and they have valued their own position too lightly. They have slaughtered competing instruments, and what has been the result? In hundreds of cases they have lost public esteem and public confidence when they could have maintained both.

NO trade ever followed the cut-rate road to permanent success. Price slaughtering may be only indulged in as business expediency, but as a permanent part to business life it should be avoided.

It leads merchants into all kinds of pitfalls, and instead of building a permanent trade, steadily lessens it and destroys the confidence of the public in values.

Talking machine dealers should appreciate the principles which the manufacturers in this trade have maintained in price standardization. It has been the solid and substantial foundation which has saved the industry during the days of storm and stress. It has saved the dealers from themselves, because many a man, in order to raise funds to meet maturing obligations, would be tempted at times to enter into a price slaughtering campaign just for temporary needs, not realizing that by so doing he would commit an act which would injure his future success.

Dealers in this trade have much to be thankful for that they have been saved from disaster—saved from the temptation of destroying their own enterprises by price annihilation.

We have seen some men in the course of our various travels who have expressed the wish to enter into a price cutting campaign. Their reasons were based somewhat on spite and somewhat on the advertising which the house would get. We have reasoned with them. We have shown them clearly the folly of such a course and we desire to impress upon every talking machine dealer in the country that it would be an act of business suicide even if it were possible under the existing conditions to make such a move.

The Clayton law, as we interpret it, does not give to any dealer that right. It simply makes him free to handle what he may desire in the way of products. In other words, he cannot be forced by any agreement into handling non-competing wares, and if any manufacturer insisted upon such an agreement, he would be violating the spirit of the Clayton law.

Do not value your trade too cheaply.

Do not figure that you are in a cutthroat and cut rate business.

Put aside such temptations and conduct your business along progressive, straightforward lines.

Rely upon the merit of your products, the tact of your sales-

men, the power of argument to make your sales and build your enterprise.

We hope never to see the time when the advertising columns of the daily papers may contain notices of slaughter prices of standard talking machines.

If a department store by underground methods secures a stock of machines in order to slaughter prices then the act should be condemned by the entire trade.

Fixity of price should be maintained, and so long as that is staunchly adhered to, there will be no fear of trade disintegration.

Stand by your guns and incidentally hustle!

Then your trade will stand by you.

ONE of the most important changes in the retail trade during the past few years has been the evolution of the show window. From being an unimportant feature of the store it has grown to be a factor of great importance along the lines of publicity, supplementing the efforts of the advertising man most effectively.

The attention that is now being given to show windows by the retail merchant is almost as great in the small towns as in the large cities, and this is especially noticeable in talking machine stores, where window and ware room display are factors which have been assiduously cultivated.

The recent improvements in store fronts and windows as designed by specialists in this work have assisted materially in creating better results in the matter of showing and selling musical instruments of all kinds. The show windows are higher and deeper, admirably lighted, and care is taken to keep them free from unsightly interfering columns or posts.

The improved window fronts in the talker trade, particularly in the smaller cities, can be attributed in a measure to the great possibilities for display afforded by the talking machine. Piano dealers who handle these remarkable promoters of musical knowledge have been educated by such concerns as the Victor Co. and other manufacturers to install special window displays which have been arranged for them, and which attract the public to the window and store where they are displayed in a manner that has awakened the dealer to a new conception of the value of window display.

EDISON DISC and CYLINDER PHONOGRAPHS EXCLUSIVELY

Dealers of New York and New Jersey

We can assure you prompt and efficient service and deliveries by reason of our being the nearest distributors to the Edison factory, and therefore in a position to keep our stocks complete and up-to-date at all times.

Eclipse Phonograph Company

A. W. TOENNIES & SON
Edison Distributors

203 Washington St.

Hoboken, N. J.

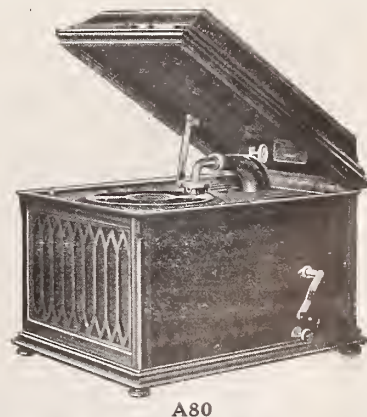

THE TRADE IN BOSTON AND NEW ENGLAND

JOHN H. WILSON, MANAGER, 324 WASHINGTON STREET, BOSTON, MASS.

(Special to The Talking Machine World.)

BOSTON, MASS., November 8.—All things considered, business in Boston and suburbs is doing remarkably well, though with a frank understanding of the situation there isn't a dealer who will not qualify his statement of fairly good business with the remark, "but it could be better." In a nutshell that describes the present condition. One thing is certain, however, and that is that the extensive exhibit of Edison disc machines at the food fair which closed on the night of October 31 has been a tremendous stimulus to business, and there isn't one of the dealers—George Lincoln Parker, Shepard-Norwell Co., F. H. Thomas Co., Chickering & Sons, and the Shepard stores of Providence—who were combined in this exhibit that is not able to report business directly attributable to the fair, or hundreds of prospects that look promising. The Swiss chalet, which occupied the whole of the stage wherein 500 people were seated, during many periods of the day, was a triumph of Edison enterprise; and Harland R. Skelton, attired in evening clothes, made a splendid presentation of the claims of the Edison proposition before the exhibition of moving pictures and moving-talking pictures was started. One clever scheme was the throwing on the screen as a preliminary the names and addresses of the houses directly concerned in the distribution of Edison outfits whose booths were nearby.

Loss Not as Great as Reported.

Manager Royer, of the Arch street Victor quarters of the M. Steinert & Sons Co., reports that the loss sustained at the fire in Worcester a fortnight or so ago was not as severe as first feared. The fire occurred in the Day building, occupied in part by the Steinert Co., early one evening, and early the next morning Mr. Royer was upon the scene. The fire was in another portion of the building so that flames actually did not come into the Steinert warerooms, so what loss was sustained was through smoke and water, much of which found its way into all the stores and offices of the large structure.

Handsome Talking Machine Warerooms.

Manager Royer is quite elated over the good business that the Boston headquarters of M. Steinert & Sons is doing, and to all those who evince an interest in the Victor proposition he is asking "Have you seen our new Boylston street warerooms?"

Now these Boylston street warerooms must take their place as among the handsomest and most conveniently arranged of any in the city. The quarters

are really the same as formerly used for the Victor business, and are on the fourth floor of the Steinert building and overlooking Boston Common, but they have been entirely made over. The center of the space, which extends the width of the building, is given over to a sort of parlor with large table in the center, on which is a collection of Victor literature. On each side are two commodious sound proof booths, into which there is a flood of sunshine all of the afternoon. On the polished floors are handsome rugs, and a feature is the record cabinet, which occupies a corner of the room, the shelves projecting out a short distance, leaving recesses between, the arrangement being similar to what one sees in a public library. In a further corner is the table for handling and doing up records. The department is in charge of Herbert Evans, and he is now able under improved conditions, to push the Victor business as never before.

Eastern Talking Machine Co.'s Campaign.

Good progress is being made at the Eastern Talking Machine Co.'s warerooms in Tremont street, where one constantly notes many customers bent on interesting themselves in the Victor line. Manager Fitzgerald, of the wholesale department, says he is going after business as never before, and that where a distributor in a town is not pushing ahead as fast as he ought, a change is immediately made. Friend Welch, who is in charge of the school work, is making a careful and thorough canvass of the outlying sections and he is approaching both public and private schools with good results.

Victrola for One of the Champions.

Manager Warren Batchelder, of the Victor department of the Henry F. Miller Co., reports that during the championship games between the Braves and the Athletics his warerooms were visited by Hugh Bedient, the famous pitcher of the Red Sox, who made a purchase of a Victrola XVI in Circassian walnut, and a bunch of choice records. He left instructions for the outfit to be shipped to his home at Falconer, N. Y. Business at the Miller warerooms has considerably picked up since Boylston street has been permanently put in order following the aggravating work on the subway.

Wallace Currier in Charge at Chickering's.

A change has been made at the talking machine department of Chickering & Sons in Tremont street. W. W. Longfellow, who has been in charge for some time, has been transferred into the retail department of the piano warerooms, and succeeding

him is Wallace Currier, son of Mason P. Currier, manager of the Chickering retail department. Young Mr. Currier formerly was with the Victor department of M. Steinert & Sons, and left to accept a position with the Standard Oil Co. The talking machine trade will be glad to welcome him back into their midst. It will be recalled that in the Chickering warerooms there now are both the Victor and the Edison disc outfits, and the exhibit of the latter machines at the food fair by the Chickering house, as mentioned in The World of last month, has been productive of a large number of sales and promising prospects. Ralph Longfellow, brother of W. W. Longfellow, has been in charge of the exhibit, and each afternoon and evening the room at the rear of the stage of Mechanics Hall has been filled during the periods of demonstration. Mr. Longfellow proved himself especially adept at explaining the Edison machines in a highly intelligent manner.

Harvey Takes on the Edison Line.

The C. C. Harvey Co. is the latest Boston house to take on the Edison goods, and although this house has been exploiting this line less than a fortnight, Manager White says there has been quite an inquiry. The large show window offers a splendid opportunity for displaying both the Victor and Edison lines, and in the showroom on the second floor the machines are being displayed to good advantage. In addition to the Boston establishment, the Harvey Co. conducts stores at Brockton and Lynn, in both of which the Victor and Edison lines are winning immediate favor.

Columbia at the Boston Opera House.

With the opening of the Boston Opera House three weeks ago for a varied nightly program of motion pictures and vocal and instrumental music, the Columbia Graphophone Co. played a conspicuous part. It happened that the Opera House was opened six years ago with Mme. Nordica, now deceased, whom Boston claimed as one of her daughters, as she received her training here. It was the idea of Manager Erisman that on the opening night of these entertainment selections of "La Gioconda," which was the first opera sung at the Opera House, should be given through the medium of Mme. Nordica's records, as that opera star sung exclusively for this company. In spite of the fact that it was asked that no applause be given as a silent tribute to the dead artist, the audience could not contain itself and broke out in one thunder of clapping. The music was played on a Columbia grand and

Getting the Goods Gets the Profits

This is particularly true about the new Edison Diamond Disc machines and records, for with a good stock on your floor, it offers a wide selection to your customer and generally lands a good sale. The tremendous demands for the new Edison line, coming from all over the country, show the superiority of not only the goods, but of the Edison dealers' lead when it comes to actual competition. We start you right and see that you "make good" from the beginning.

Better talk this over with us now.

THE PARDEE-ELLENBERGER CO., Inc.

Boston, Mass.

New Haven, Conn.

**Real Music
At Last**

**NEW ENGLAND
JOBBER**

EDISON DIAMOND DISC
AND CYLINDER
PRODUCTS.

THE TRADE IN BOSTON AND NEW ENGLAND

JOHN H. WILSON, MANAGER, 324 WASHINGTON STREET, BOSTON, MASS.

was highly enjoyed. The entertainments, it may be stated in passing, have proved a most successful venture. The downtown box office is in the Columbia warerooms.

C. E. Osgood's Attractive Display.

Chester J. Sylvester continues to exploit to advantage the various makes of machines, the Columbia, Edison and Victor, in his well-appointed warerooms at the rear of the C. E. Osgood Co.'s furnishing house establishment. This house has always been one of those that have built up a big business on the instalment system, and in disposing of its talking machines it has found favor with a large class of people.

Keeps in Touch with Branch Houses.

Manager Royer, of the Arch street Victor quarters of the M. Steinert & Sons Co., is making frequent trips just now to the various out-of-town houses of the Steinert concern, such as Providence, Fall River, Portland, Worcester and other cities. Mr. Royer always finds much to commend in the management of the branches, and those under his jurisdiction are not slow to profit by his business talks which he occasionally gives. Lately Mr. Royer added to his staff Frank Roby, who is acting as the educational agent for the house.

Joins the Columbia Forces.

R. C. Sylvester, brother of Chester J. Sylvester, manager of the talking machine department of the C. E. Osgood Co., is back with his first love, the Columbia Graphophone Co. Mr. Sylvester left here about a year ago to go to Worcester, where he was with the talking machine department of the Atherton Furniture Co., but he was not altogether satisfied, and was glad to come back to Boston. He resumed his duties under Manager Erisman on the first of the month.

Oliver Ditson Co. Prepares for All Demands.

The Victor department of the Oliver Ditson Co. is forging ahead in good shape, and the indications are good for a busy holiday season. Manager Winkelman reports that October made a showing considerably above that of last year. The house is carrying a large stock of machines and records, and is splendidly prepared to cater to the needs of its customers this fall and winter—particularly during the Christmas holidays. Its attention to orders and its valuable "service" to dealers is keenly appreciated.

Use Talking Machines for Dancing.

Ashley Kendrick, who was one of the first to introduce the modern dances into Saratoga Springs, N. Y., his home city, was a visitor to Boston recently. Mr. Kendrick is an enthusiast over the use of talking machines in dancing studios, and he has used the Victor and Columbia outfits with great success. He has just opened his studio for the second season, and the winter promises to be an unusually successful one.

No Dull Times with Columbia Co.

"It just about makes me tired when I hear dealers prate about poor business," declared Arthur Erisman, manager of the Boston quarters of the Columbia Graphophone Co. "We have seen very little indication of poor business in Columbia goods, and when I say that we closed October with the largest single month's business in our history, I think that tells a story of hustle and enthusiasm on the part of Columbia distributors. I may add that while December of last year was considered the banner month in our experience, this October's business was considerably in excess of that." Mr. Erisman reports that many large business houses throughout New England have been taking on the Columbia lines, and special mention is made among those nearer home of D. B. H. Powers, of Lynn, a large furniture house, which has taken on a complete stock of Columbia machines and records. Mr. Powers intends to immediately inaugurate a big advertising campaign. Another large Lynn concern to stock up with Columbia outfits is H. M. Curtis, who runs a store at 60 Andrew street.

Pardee-Ellenberger Co. Expansion.

Manager Silliman, of the Pardee-Ellenberger Co., states that business in the Edison lines is making surprising headway throughout New England, and everywhere there is a big call for goods. Mr. Pardee continues to make his periodic trips over from New Haven, and he always returns home well satisfied with the business progress. The present handsome and large quarters have insistently proved the need of expansion, and when one compares the handsome suite of warerooms and offices with the small second-story quarters of a few months ago it is evident that business with the Pardee-Ellenberger Co. has made enormous strides.

Some Recent Visitors.

C. E. Goodwin, general manager of the Phonograph Co. of Chicago, was a recent visitor at the Eastern Talking Machine Co.'s quarters. Another visitor who paid his respects to Manager Taft in the past few weeks has been George D. Ornstein, chief of the Victor salesmen, who passed through Boston in his automobile while making a tour of the New England jobbers.

Charles Garb Seriously Ill.

Charles Garb, one of the proprietors of the Conclave Phonograph Co., which recently moved from Portland street to Cornhill, as mentioned last month, is seriously ill. It happened that his son-in-law was here from the Northwest at the time, and though himself engaged in a different line of business, he has stepped in to help out in the conduct of the business. It is not thought that Mr. Garb is dangerously ill, though it may be several weeks before he will be able to get back to business.

Will Soon Return to Business.

The many friends of John A. Alsen, head of the talking machine department of George Lincoln Parker, will be glad to learn that he has left the hospital, where he has been for a fortnight, and will now convalesce at home. It doubtless will be several weeks yet before he is able to return to business.

Trade Interferences Disappearing.

When this issue of The World is read Avery street, which is to so immeasurably benefit the Columbia Graphophone Co.'s Boston headquarters, will finally be finished after months of incessant work. The sidewalk along the side of the Colum-

bia store has been completed some time, but the roadway, because of numerous delays, has not been made passable until now. For more than a month the Columbia store has had the side facing Avery street adorned with conspicuous gold and black signs, and there is no question that since the opening of this new thoroughfare business has taken on a new lease of life, for the store and the business meet the eye from so many different angles.

A. W. Chamberlain Appointed Manager.

Arthur W. Chamberlain, well and pleasantly remembered as manager of the wholesale department of the Eastern Talking Machine Co., has been appointed manager of the talking machine department of the Iver Johnson Sporting Goods Co., which occupies an entire building at the corner of Washington street and Cornhill. In the talking machine department, which is located on the fourth floor, both the Edison and Victor outfits are featured. The department has been without head for several months, and Mr. Chamberlain was selected as just the man fitted by long experience in the trade to put it on its feet.

In Charge of Suburban Business.

W. C. Frohock, who has been with the talking machine business for some time, and is considered a valuable man, has become associated with the Columbia Co., and is in charge of the suburban wholesale end of the business.

Opens a New Addition.

The C. C. Harvey Co., Boylston street, has opened up an addition to its talking machine parlors, and the new rooms which are at the rear of the old quarters have been rebuilt, redecorated and beautifully fitted out so as to make them handsome and restful. The walls are tinted in cream and white, and the windows and doorways are fitted with silk rep hangings in old rose with gold trimmings. Except for daylight the rooms are otherwise lighted by brass electroliers, and large rugs cover the polished floors. Dainty tables and chairs help immensely in the furnishings. The Edison and Victor machines are arranged about the rooms, and the fact that the suite is some distance back from the street insures perfect quiet in listening to records. Manager White has an efficient staff to assist him in displaying and demonstrating the goods.

THE BAGSHAW test for talking machine needles begins where others leave off, and every needle must come up to our high standard of quality.

It is this strict attention to small details that spells "perfection" in the manufacture of quality needles and being the pioneer manufacturer in this field, we know just how to care for the demands of the trade.

Bagshaw needles are tone producers. The largest sale of any needle on the globe.

W. H. Bagshaw, Lowell, Mass.

Nothing at \$100 can compete with the new Columbia Grafonola "Mignonette" and at \$110 the "Mignonette" equipped with the exclusively Columbia Individual Record Ejector is sure to appeal to a wide market *all its own.*



(Write for "Music Money," a book "full of meat" for those dealers interested in quick and frequent turnover of capital.)

Columbia Graphophone Company
Woolworth Building, New York

CHARGE SIX PER CENT. INTEREST ON INSTALMENT SALES.

The Talking Machine Association of Buffalo at Its Recent Meeting Unanimously Adopts That Selling Plan—Department to Put This Policy Into Force—Action Also Taken in Regard to the Purchase of Records Sent for Trial to the Home.

(Special to The Talking Machine World.)

BUFFALO, N. Y., November 5.—On October 21 the members of the Talking Machine Association of Buffalo held its regular meeting at the store of W. D. Andrews, where it was called to order by W. H. Poling, president. Practically all of the members attended, and during the evening a photo-

ference between the cash payment and the amount on lease, and to do so would require a borrowing line at the bank, and the proper course would be to simply charge the customer the amount additional to offset the cost of borrowing the money from a bank.

Another measure put through was that of re-

Among those present were: W. H. Poling, president; A. F. Schwegler, secretary; Chas. H. Heinike, Chas. B. Utley, Wm. L. Sprague, Henry Schunke, I. Melzer, Albert W. J. Schuler, H. G. Town, Albert S. Winegar, Robt. L. Loud, W. F. Gould, W. J. Bruehl, Chas. Bieda, Glad. Henderson, of The Talking Machine World; George Goid, Geo. Todd, C. N. Andrews, A. V. Biesinger, treasurer; Martin Kaepfel, R. G. Richardson, E. C. Emens, Wm. Laufer, Alvin Kaepfel and W. R. Gardner.

"PULLED OFF A CLEVER STUNT."

Under the above head the Gazette and Bulletin, of Williamsport, Pa., published the following: "Walter Lamade, of the Lycoming Opera House, and Charles Brownell, of D. S. Andrus & Co., worked a very good trick yesterday while Mr. and Mrs. Vernon Castle were doing their fancy dancing in the moving picture show. Mr. Brownell had Roy Bell, of the Victrola department, behind the scenes with a Victor-Victrola, and the very dance records which the Castles had superintended the making of for the Victor Co., these records being taken out of the regular D. S. Andrus & Co. stock. The dancing of Mr. and Mrs. Castle was truly beautiful and artistic and the music furnished by the Victrola absolutely perfect. The dancers were always in perfect step with the music."

399 OUT OF 400 VOTES FOR EDISON.

"The Edison disc is elected by an overwhelming majority." Such was the word passed along by members of the Knights of Pythias Lodge, Coshocton, O., recently. There had arisen a discussion of what kind of talking machine the lodge should acquire. Stevenson Bros., Edison dealers there, appeared on the scene and offered to play the Edison disc at the next lodge meeting, and leave the decision to a vote. Out of 400 members of the lodge the Edison received 399 actual votes. An Edison disc was purchased and is now a much admired acquisition, says the Edison Phonograph Monthly, being in constant use by some member of the lodge every evening.



Seated on Floor: Geo. Todd, C. N. Andrews. First Row, Seated: I. Melzer, A. F. Schwegler, Sec'y; W. H. Poling, Pres.

graph of the group was taken by The Talking Machine World and is for the first time published herewith.

The usual form of business was conducted, the main feature being the signing of the agreement by the dealers to charge interest at 6 per cent. on instalment sales, which was unanimously adopted. One member, in explaining this plan, stated that inasmuch as the cash price is fixed, to sell on instalments would be to practically advance the dif-

ference between the cash payment and the amount on lease, and to do so would require a borrowing line at the bank, and the proper course would be to simply charge the customer the amount additional to offset the cost of borrowing the money from a bank.

The next regular meeting will be held at the offices of Robt. L. Loud.

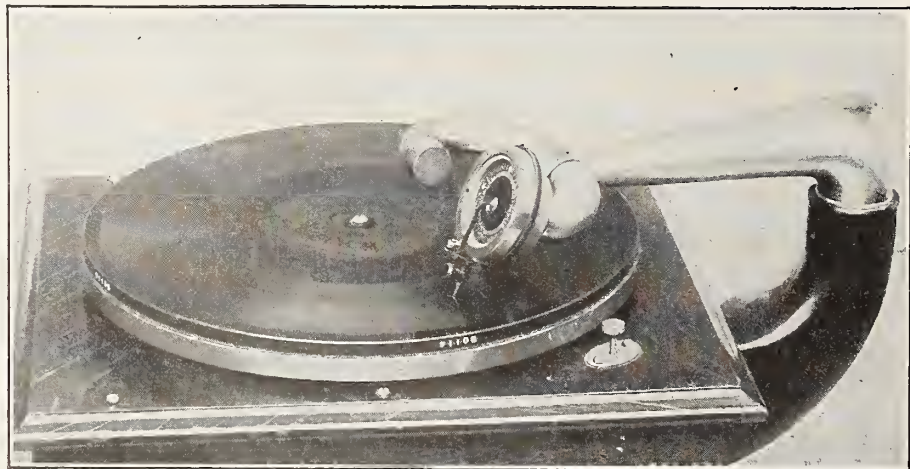

DO YOU WISH TO PLAY EDISON DISCS?

Price \$2.00

(Sample to Dealers \$1.00)

LEXTON SPECIALTY CO., 216 West 99th St., N. Y.

We FILL Victor Orders!

THAT'S the whole story in four words.

You want what you want when you want it—and from us you'll **GET IT!**

Records, Machines or Accessories—it's all the same. If anybody has a complete stock—we have!

No matter how far you are from Saint Louis, you're near enough to get the benefit of our order filling service.

If your regular jobber is "Short," just try us. We "dote" on "Shorts."

Koerber-Brenner Company



Victor Distributors

Saint Louis



Harry G. Koerber
President & Treasurer

Edwin C. Rauth
Vice-President & Secretary

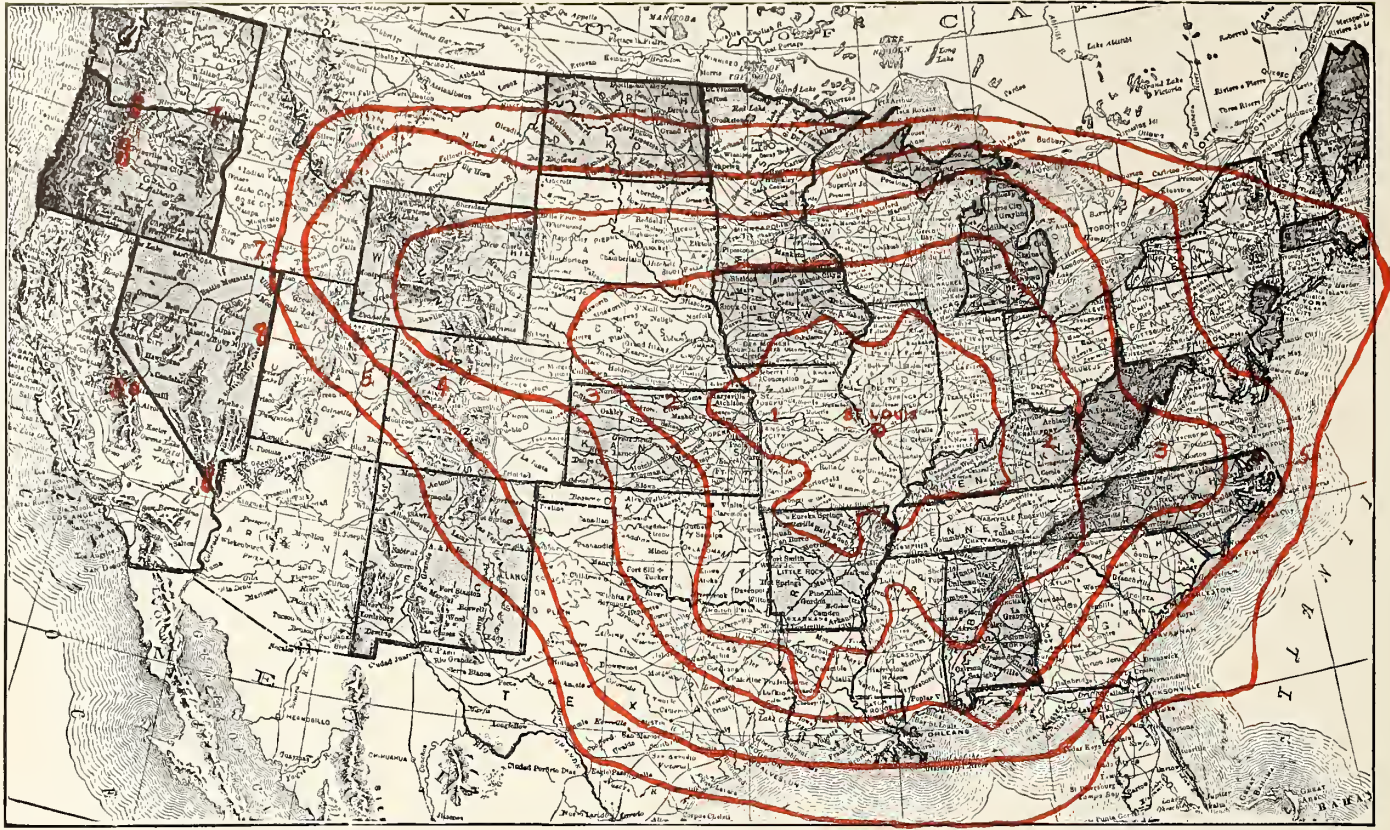

Saint Louis— America's Center!

LOOK at the map!
Those circles represent the scheduled freight package car service from Saint Louis. Every circle represents one day from here.

Over twelve hundred package cars leave Saint Louis each day—to break bulk at distant points. These cars arrive **ON SCHEDULE!**

That's why the freight service from Saint Louis is so superior.

Express and Parcel Post service is just as superior, for Saint Louis is America's **CENTER**. It's the most accessible market point.

And here in Saint Louis—practically at your very door—is a Victor stock so large that we **SOLICIT** the orders for goods that other jobbers can't fill. We **SOLICIT** such orders!

Give your regular Victor business to whichever jobber you will—and give us the orders for goods you can't get from him. Our superior shipping facilities will land the goods in your store in the shortest possible time.

Koerber-Brenner Company



Victor Distributors

Saint Louis



Harry G. Koerber
President & Treasurer

Edwin C. Rauth
Vice-President & Secretary

Every Record User a Positive Customer

The "DUSTOFF" is a positive necessity to every user of Records.

Cleans All Makes of Records

Ensures clear, distinct tonal reproduction free from blurs, scrapings and harsh sounds.

"DUSTOFF"

(Regular 15c. Model)

RECORD CLEANER

Their use adds life to records—"DUSTOFF"s get into the minute sound grooves and thoroughly remove accumulated dust and dirt.

GET THE GENUINE "DUSTOFF"

Of all good jobbers, or write to us direct.



MINUTE SHINE COMPANY

(Originators and Pioneers)
283 Canal St., Providence, R. I.

15c.

Model

40% Discount

PROGRESSIVE ARGENTINE HOUSE

Is That Conducted by Jose Tagini, of Buenos Aires, Whose Publicity Is Up to Date.

The Columbia Graphophone Co. has received from its representative in Buenos Aires, Argentine Republic, South America, Jose Tagini, a series of handsome window hangers which well illustrates the progressiveness of this prominent house and the co-operation it is ready to extend to its dealers. These hangers are devoted to special supplements of Columbia records, and, as Mr. Tagini terms them, they are "messengers of peace and prosperity."

In a letter to his dealers Mr. Tagini urges them to make a special effort to increase their Columbia record trade this season, and points out that if proper attention is bestowed on the development of their business, they will forget all about the war in Europe, and increase their profits steadily. Jose Tagini conducts one of the largest talking machine establishments in the world, and the manager of his business, Ernesto S. Tosi, is fully conversant with all the most important selling helps which contribute to the success of a wholesale and retail talking machine business.

OPTIMISM MORE APPARENT

In Various Parts of the Country, Says Philip Ravis, of the New York Album and Card Co.

"Business conditions throughout the West are steadily improving," said Philip Ravis, vice-president of the New York Album and Card Co., 23 Lispenard street, New York, who returned recently from an extended trip through this territory. "Optimism is becoming more and more apparent, and judging from the reports of the dealers, this season will be a banner one. Our record albums are giving perfect satisfaction in every respect, and our recently announced features have been very successful. With the advent of the holiday season and the issuance of the semi-annual record catalogs, there is considerable interest being manifested in our flexible cover for holding these catalogs, and many dealers have arranged to use large amounts of these covers to present to their customers as holiday souvenirs and to sell at a nominal price."

BUSY TAKING CARE OF DEMANDS.

The Past Month Has Shown a Rapid Growth Throughout the Country of the Business of the Pathé Frères Phonograph Co., New York—Many New Dealers Established—Dance Records Win High Praise from Purchasers.

During the past month the Pathé Frères Phonograph Co., 29 West Thirty-eighth street, New York, has been kept busy taking care of the demands of its already established trade, and arranging for representation in large and small cities throughout the country. The announcement that the company is now fully prepared to handle its American business, created wide-spread interest in the trade, and the fact that it had completed a perfect selling plan and was equipped to make immediate shipments of Pathephones and Pathé discs enabled it to secure prompt distribution.

Referring to the present status of its business, an officer of the Pathé Frères Phonograph Co. remarked as follows: "We are receiving from all parts of the country unsolicited letters of praise from our dealers relative to the musical quality of

these records are from all the usual defects. They certainly are an artistic innovation and will be highly valued by all lovers of music. Believe me,

"Faithfully yours,

"LIONEL S. MAPLESON."

THOMPSONS CELEBRATE.

Phonograph Plays Part in Wedding Anniversary Held Recently.

Mr. and Mrs. William H. Thompson (Isabel Irving), celebrated the fifteenth anniversary of their marriage recently. Mr. Thompson is playing the Patriarch in George M. Cohan's "The Miracle Man" at the Astor Theater, and Miss Irving is appearing in "Under Cover" at George M. Cohan's Grand Opera House in Chicago. The two organizations gave a dinner to the happily married pair after the performance on the anniversary date. A feature of the event was a speech by Mr. Thompson to the guests at his wife's dinner in Chicago, and one by Miss Irving to the guests at her husband's dinner here, the same being delivered in phonographic form, the records for which were made a few days in advance.

NEW ATTACHMENT PLEASES.

Lexton Specialty Co.'s Device for Playing Edison Records on Victor Machines Meets with Approval of the Dealers, Who Are Reordering Liberally After Trying Device.

The Lexton Specialty Co., 214 West Ninety-ninth street, New York, manufacturers of the Lexton attachment, which permits of the playing of the Edison type of records on Victor talking machines, reported that the trade has displayed an unusually live interest in the new device, and that orders, both for samples and quantities, have been numerous. The fact that a large number of jobbers and dealers have, after trying out the sample, been quick to place repeat orders, speaks well for the claims of the inventor, A. G. Ostermoor, regarding the reproducing qualities of the device.

The Lexton device is readily attached to the gooseneck of the machine by unscrewing the cap and screwing in the attachment which throws the sound box around at right angles to the record

YOUR ADV WILL LAST YEARS

printed on labels on the

"DUSTOFF"

(Regular 15c. Model)

RECORD CLEANER

You can now have the "DUSTOFF" made to your special order with YOUR OWN ADVERTISEMENT on labels without extra charge on orders of one gross or more.

Place order with your jobber, specifying "DUSTOFF"s made by us, or send us the order direct. Proof shown in one week; delivery two to three weeks later. GET YOUR ORDER IN NOW, in time for holiday distribution.



MINUTE SHINE COMPANY

(Originators and Pioneers)

283 Canal Street, Providence, R. I.

our products, and the agencies which we have established are placing repeat orders with pleasing regularity. All indications point to our closing a business this year far in advance of our highest expectations, and our dance records are scoring a remarkable success. The fact that these records were produced under the supervision of Maurice and Florence Walton, assured their being recorded in perfect dance tempo. The higher priced Pathephones are giving excellent satisfaction to all purchasers, and the dealers handling our products have commended us on our prompt and efficient service. We are receiving shipments regularly from abroad, and are co-operating with our dealers in every way that will enhance the sales possibilities of our line.

"We have received an interesting letter of praise from Lionel S. Mapleson, London representative of the Metropolitan Opera Co., New York, one of the foremost musical authorities in the world. Mr. Mapleson, who is at present in New York, has written us as follows:

"Allow me to congratulate you on the issue of the records that I heard at your Thirty-eighth street studio to-day. It is really remarkable how free

50% Now Given!

40% was the former dealers' discount—now increased to 50%.

"DUSTOFF" De Luxe RECORD CLEANER

Retails for 50c.

Made on handsome oxydized metal holders, put up each in a box and every dozen in a handsome counter display carton.

Stocked by good jobbers, or write to us direct.



Patented

MINUTE SHINE COMPANY
(Originators and Pioneers)
283 Canal Street, Providence, R. I.

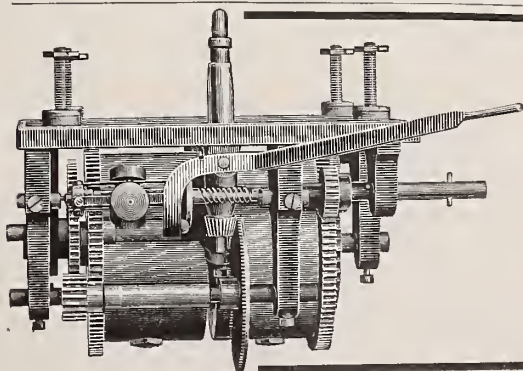

Manufacturer of Talking Machines

JOHN JACCARD

Successor to JACCARD BROS.
Culliairy, Ste. Croix (Switzerland)

Established 1862

Specialists in mechanism and accessories for Talking Machines. Twenty different models of mechanism.

groove and presents it at the most effective angle to the record face. The new Lexton permanent needle for use with both vertical and lateral cut records is also a feature of the device, and several dealers, in placing reorders for the Lexton device, have written of their satisfaction with its performance and the manner in which the needle brings out the tonal quality of the records.

The Lexton Co. now has a liberal supply of attachments and needles with which to fill orders without delay. At the present time the device is made only for Victor machines, but a new model, designed for Columbia machines, will be announced at an early date.

VIEW OUTLOOK OPTIMISTICALLY IN CLEVELAND.

All Branches of Talking Machine Trade Report Healthy Undercurrent in Business World Despite the Adverse Conditions Which Have Affected Seriously Many Lines of Business—Every Evidence That Dealers Mean to Close a Satisfactory Year.

(Special to The Talking Machine World.)

CLEVELAND, O., November 9.—Early fall traffic all along the line in the talking machine trade is exceptionally good, notwithstanding the general adverse conditions which have seriously affected many lines of business.

Sales practically cover the entire list of machines from the cheapest to the highest priced, and largely cash transactions prevail. A preponderance of transactions are in the fifty to one hundred dollar instruments.

The various dealers are pleased with present conditions and optimistic regarding the future, particularly the approaching holiday business, which is already manifest in some of the stores.

The Union Specialty Co. report business as improving very materially. The demand for talking machine Union specialties, it was stated, continues good and constantly increasing.

L. C. McChesney, advertising manager of Thos. A. Edison, Inc., spent a day recently visiting the Phonograph Co. and the various dealers in the city.

Geo. W. Savage, an experienced talking machine man, has accepted a position with the Eclipse Musical Co., and will prove a valuable acquisition.

Hedwig Hart has also joined the forces of the Eclipse Co. and is fast garnering new friends for himself and the company.

Grant Smith is manager of the Euclid Music Co., Victor dealers. His management during the past year has demonstrated his efficiency as a talking machine dealer.

One of the signs of prosperity is a look in at the Euclid Music Co.'s store. The attaches are busily engaged, though under difficulties, as extensive improvements are under way. Three additional large parlors are being fitted up for the benefit of customers to insure their prompt attention. The company

started a year ago, and it was rather experimental. The store is located in a fine residential section, and the business has been constantly increasing. It is open every evening and has the advantage of downtown stores in the fact that business men do not have to rush in at lunch hour, hear a record and ask to have a bunch of records sent on approval. This store being conveniently located, the customer brings his wife along and they leisurely select the records, which are sold, not to be returned in a few days for a fresh lot. And it is the same way in selecting a machine. The man, accompanied by his wife or daughter, goes to the store in the evening, and they take their time and select an instrument to their entire satisfaction.

The large and attractive piano house of the B. Dreher's Sons Co. is a magnet that draws large crowds. The talking machine department is especially attractive and is doing excellent business. "Trade this fall," said W. G. Bowie, manager of the department, "has been considerably better than in 1913. This, of course, is very encouraging, and we hope and expect to have the largest Victor business during the holidays that we have had in all previous years."

The Phonograph Co. of Cleveland, distributors of the Edison products, is reaping the success which the Edison instruments entitle it to. L. N. Bloom, secretary, reports business for the month of October was exceptionally good in both the wholesale and retail departments. The company has just installed one of the largest electric signs in the city, the entire length being 105 feet. It gives on one end an exact reproduction of the new Edison diamond point reproducer in action, the record underneath continually revolving. On the other end of the sign is a large disc record with a lifelike picture of Mr. Edison in the center. This

also is revolving continually. It is, without doubt, one of the most novel and handsomest signs in the country. The recitals given by the company afternoons and evenings are well attended and are proving a valuable means of publicity.

When a man is on the jump from early until late, as is Mr. Denslow, manager of the Eclipse Musical Co., it is evident there is something doing. "Machine sales are being daily recorded," he said, "and the tendency is toward more cash sales, larger down payments and shorter terms on contracts."

O. E. Kellogg, secretary of the H. E. McMillin & Son Co., announced to the trade last week that the company would discontinue its Edison department. He stated that the reason for discontinuing the department was due largely to its increased Victor business.

"The business in the graphophone department of the Grafonola Co. during the month of October," said Mr. Roth, president, "has held to the same amount of increase that prevailed during the preceding months. I think a good many people who would have bought pianos the past summer have purchased Grafonolas because they wanted music in their homes and were timid about entering into a piano contract on account of their lack of confidence in the business situation. Our business is very good, and I am pleased to state that our collections have been and continue to be excellent. Part of this is due to the fact that we do not let the accounts lapse into arrears without good cause. Again, a part is due to the fact that the workingman is not banking his money, but laying it by in the old historic teapot; consequently when the collector calls he has some cash on hand to meet the bill. We are satisfied with conditions."

During the past summer the remodeling of the store of Wm. Taylor, Son & Co. has been under way, four stories being added, doubling its capacity. This enlargement has afforded the talking machine department greatly increased space. Ten new, large graphophone demonstration rooms have been beautifully fitted up and opened on the fourth floor. T. A. Davies, manager of the section, claims it is the finest in this part of the country.

The magnificent Victor window display by the Caldwell Piano Co. is one among the many attractive ones in the city. All the various types of machines are shown. R. W. Schirry, manager of the department, stated business was holding up remarkably well, and especially good for the November dance records.

The George D. Koch & Son Co., large furniture dealers at 10300-12 Euclid avenue, have taken on the Edison line.

Trade conditions at the store of the W. F. Fredrick Piano Co. are satisfactory, especially in the Victrola department. The company has a large, fine stock of machines and records, and reports the outlook for holiday trade most encouraging.

The Story & Clark Piano Co. has opened an exclusive Edison phonograph department, with a large, fine stock of instruments, and report good business. H. L. Tinker, formerly with the May Co., has returned to the city, after an absence of four years, and is engaged with the company.

The Hart Piano Co., The Arcade, is having a fine run of trade in talking machines.

The recent enlargement of the May Co. store has afforded the talking machine department large additional space. Eight beautiful demonstration parlors have been artistically arranged for the convenience and comfort of customers and the transaction of business on the fourth floor. A large Victor trade is reported and conditions improving.

Phil Dorn, manager of the Collister & Sayle Co., says business in the talking machine department might be better, but that it is very satisfactory.

Business is fine at the Columbia store and Mr. Madson is elated over the prospects, Columbia dealers in this territory are all doing fine and have made extensive arrangements for the holiday trade.

The W. H. Buescher & Sons' Co. is busy and, with a fine stock of Victor goods to select from, Mr. Buescher anticipates a large holiday trade.

Mr. Friedlander, of the Bailey Co., says business as a whole is way ahead of last year, and that, judging from prospective buyers, the outlook in the talking machine line is most encouraging.

ADD TO YOUR RECORD PROFITS

BY PLACING THIS HANDSOME FLEXIBLE COVER IN THE HANDS OF YOUR PATRONS

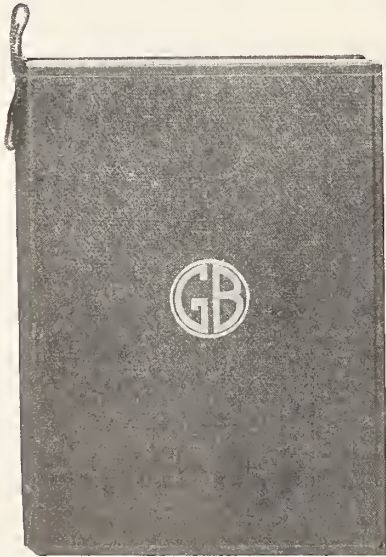

This attractive flexible cover is designed to hold the Victor or Columbia semi-annual record catalog, and is bound in mahogany colored imitation leather, and lined with black silk cloth. The price of this flexible cover is so low that it permits you to give same free to your customers with the record catalog enclosed, thereby making a useful souvenir and a permanent advertisement; or you may charge a nominal sum for it if you desire. In lots of 100 or more, your name will be stamped on face of cover in gilt lettering free of charge.

No More Scratching of Cabinets and Tables by Record Albums

Our Albums are now equipped with LEATHER COVERED RING PULLS

This ring pull, which matches the album in color, makes the handling of the book easier than with the plain leather pull, and has all the practical advantages of the metal ring. This ring pull, being leather covered, cannot mar or scratch the highest polished cabinet or table.

NEW YORK ALBUM & CARD CO., Inc.
23-25 Lispenard Street - - - New York



FELT-LINED CABINETS
OFFER THE ONLY SURE
RECORD PROTECTION

SALTER CABINETS—
STANDARD IN THE
INDUSTRY

A COUNTERSUNK
TOP OFFERS A
SECURE BASE
FOR MACHINE.



FELT-LINED
COMPARTMENTS
PREVENT
SCRATCHING
AND WARPING.

SIMPLE BUT
EFFICIENT
FILING SYSTEM.

EACH RECORD
EASILY ACCESSI-
BLE.

ORDER
NOW!

ORDER
NOW!

CABINET No. 112 WITH COLUMBIA "FAVORITE"

EDISON DEALERS ARE
DELIGHTED WITH THIS STYLE

Added Profits Are Plentiful in Holiday Season

HARMONY IN
DESIGN AND FINISH



CABINET No. 180 FOR EDISON No. 80

"Just before Christmas" is the dealer's big season. It is by far the greatest chance for accessories and "extras."

What profitable extra have you to offer the buyer of a small machine? Sell them a Salter Cabinet.

Call upon your old customers, too. They have felt the need of a cabinet by this time, and will buy without hesitation.

With these cabinets in the house the machine owner will buy more records. He can't say "The house is all 'cluttered up' with records already."

Our record storage cabinets are holiday winners also.

OVER TWO DOZEN STYLES
Get catalog and prices

SALTER MFG. CO.

339 No. Oakley Blvd., CHICAGO

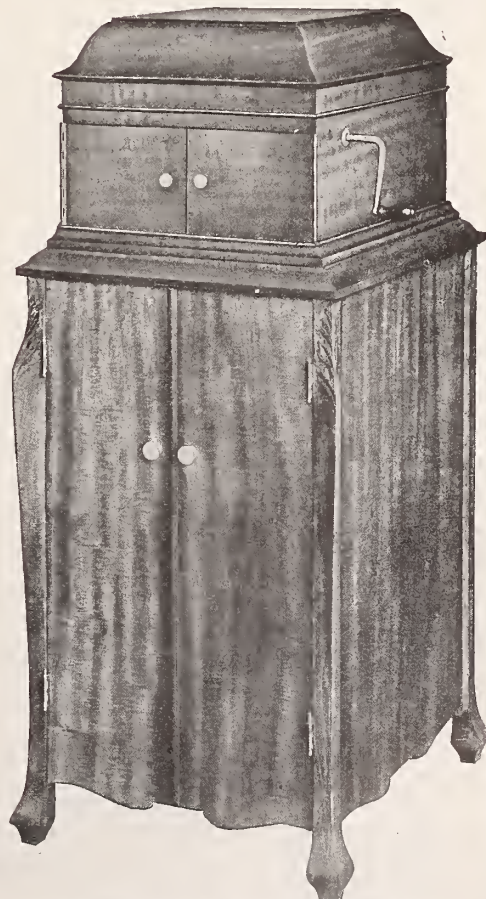

CABINET No. 19 AND VICTROLA IX



Think of offering the interested public a line of musical instruments without the Columbia Grafonola "Favorite" at \$50, for instance!



(Write for "Music Money," a book "full of meat" for those dealers interested in quick and frequent turnover of capital.)

Columbia Graphophone Company
Woolworth Building, New York

HOW TO MAKE INSTALMENT BUSINESS PROFITABLE.

A Subject of Exceeding Interest and Value to the Talking Machine Dealer Discussed by Marion Dorian, Treasurer of the Columbia Graphophone Co.—Sets Forth Rules to Be Observed by Dealers If Success Is Desired—Terms of Sale Must Be Enforced.

We hear about the difficulties incident to instalment business. If dealers have had losses with this class of business it is largely because they have not gone about it in the right way.

There are five cardinal rules for the successful handling of instalment accounts. These have been thoroughly tested, and a fair try-out will prove them powerful aids in making instalment business what it ought to be.

There are exceptions to all rules, and circumstances will arise when it is wise to suspend the rule temporarily. In such cases the sensible dealer will act accordingly.

The five rules follow:

1. Investigate the customer in advance of delivery of goods.
2. Sell him no more than he can pay for comfortably.
3. Let terms be simple and clear-cut. Make sure the customer understands and accepts them.
4. Enforce those terms.
5. Do not allow arrears to accumulate.

Three-fourths of the trouble dealers have with instalment accounts is due to anxiety to secure a good sale. Insufficient or no investigation is made as to the responsibility, reputation, or antecedents of the customer. The sale is hurriedly consummated, the goods delivered and shortly thereafter the dealer learns to his sorrow that the customer is not what he represented himself to be. In many instances both customer and goods disappear.

It is easy to ascertain all it is necessary to know about the customer. His resources and income; his reputation for prompt payment and his general standing in the community. This should be done before the goods are delivered and will insure you against surprises.

Rule 2 is equally important. The advance in-

vestigation informs you as to the prospect's income; how permanent it is and what demands are made upon it by his family. With this information in your possession you can determine what it is safe to sell him. Suppose a prospect receives a salary of \$20 per week and has a family of four. If he has been receiving this salary for some time and his reputation is good you are justified in assuming he can safely pay \$2 or \$3 per week. More than that is dangerous, because allowance must be made for possible sickness of some of his family, which will make greater than ordinary demands upon his income. Eight to twelve months is the period within which an outfit should be entirely paid for. Allowing for a \$2 a week payment spread over eight months a customer could in that time pay for an outfit costing \$64. That would be the limit which the wise dealer would sell him. Many dealers make the mistake of selling a customer double the amount he can pay for comfortably, with the result that the payments become harder as they multiply and each payment day the customer feels he is carrying a burden. Consequently his attitude becomes one of antagonism and he pays grudgingly, whereas if sold a bill he can pay for comfortably, he does it cheerfully.

Many customers who buy goods on the instalment plan are of limited business experience. A complicated instalment lease is to them an incomprehensible thing. Your lease should be as simple and clear-cut as is consistent with adequate protection. The terms of the contract should be made clear, and customer should accept them in all particulars. Salesmen should be prohibited from making verbal agreements with customer. If special terms are made these should be written into the contract itself. If this is not done disputes are apt to arise which are destructive of the

mutual confidence which must exist to insure a continuance of patronage. The customer should be furnished a copy of the contract, so that he can refer to it at any time. In this way you gain the customer's confidence and he will not only give you his own future business, but induce his friends to do likewise.

Terms should be as reasonable as you can afford, but once these have been agreed upon and accepted they should be enforced rigidly. There is no casier way to spoil good customers than by giving the impression that terms are mere formalities. There is no surer way of getting a list of accounts in bad condition than by ignoring the regular date when an instalment is to be paid. If the customer has agreed to pay on Monday train him to make the payment on that day and not on some other day. If his payment is not made on Monday notify him immediately to bring in the payment or make it to your collector without further delay. The moment the first lapse occurs, get right after him and remind him that the goods were sold on definite and accepted terms, and that you expect him to perform his promise. If his payment has not been made by the close of business on Monday have the collector at his place of business or residence on Tuesday morning and you will save money. Even the most obdurate customer will respond to this kind of treatment, especially if the call is made promptly.

If you enforce the terms and train the customer to make payments regularly no arrears will accumulate. If you allow two or three payments to lapse it is like drawing eye teeth to get a customer to make up the arrears. You may secure subsequent payments regularly, but lapsed payments hang fire until the end. Instead of getting your account settled within the contract period it runs over some months, and persistent dunning, which often results in the loss of a good customer, is necessary, to say nothing of the added expense to which the dealer is put.

These rules may not be new nor be presented in a novel way, but if followed they will result in better and more profitable instalment accounts. They may be summarized as selecting a customer wisely; selling him judiciously; starting him correctly; keeping him in the straight and narrow path, and, finally, making him an asset because you have sold him an article which has afforded himself and family unlimited pleasure, and made it possible for him to pay for it without discomfort. You have made a lasting friend.

EFFECTIVE DEALERS' PUBLICITY.

The New York Talking Machine Co., 81 Chambers street, New York, Victor distributor, is sending out to its dealers this week something novel in the nature of a slip featuring the words of that old-time favorite selection, "Mighty Lak' a Rose." This song was presented in the November list of new Victor records placed on sale the 28th of last month, and this slip is being used to excellent advantage. In preparing this dealer help, cognizance was taken of the fact that a large percentage of the dancing public likes to hum the song to which they are dancing, and in furnishing this slip these desires will be considerably facilitated.

"Standard" Record Cleaner

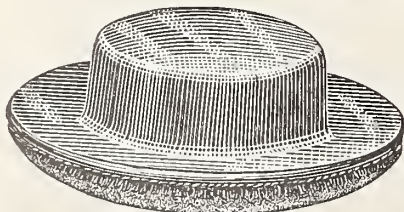

Price, 50 Cents, List
Patented June 2, 1914.

Send 10 cents in stamps for a sample cleaner. Write on your business letter head only. Place regular orders through your jobber.

STANDARD GRAMAPHONE APPLIANCE CO.
173 LAFAYETTE STREET NEW YORK

We also manufacture the Simplex Record Cleaner, Price 15 cents, list.

ARTISTIC AND ATTRACTIVE

Grips the record surface and clings as if on rails.

Extended brush area cleans record with one sweeping circuit.

KEEPING UP WITH THE DEMAND FOR VICTOR PRODUCTS.

The Victor Co. Compelled to Continually Enlarge to Supply Tremendous Demand for Machines and Records—New Grinding Plant, New Building for Shipping Department and New Power Plant Latest Evidences of Desire to Supply Needs of Trade.

The additions to the plant of the Victor Talking Machine Co. in Camden, N. J., made for the purpose of keeping at least in sight of the demand

affords an excellent idea of the progress being made on the new grinding plant, which will go far to reduce the possibility of record shortage in the future. Work on the new building is being rushed at full speed, and the plant will be put in operation as soon as completed.

Further increase in the facilities of the Victor Co. is marked in the erection of a building to house the shipping department, which will occupy an entire city block at Front and Cooper streets, Camden, N. J. When the new building is completed the present shipping department will be used for storage purposes. Other recent Victor improvements include the construction of two bulkheads built into the Delaware River at a cost of \$25,000, which will provide the plant with additional one and a half acres of ground. The bulkheads will also provide for extensive wharves capable of accommodating vessels of twelve foot draft.

A new power plant is also being constructed in connection with a new pumping station. The power plant will include a 5,000-horsepower boiler, and the pumping station will be equipped with direct connecting turbine engines. It will have a



New Shipping Department Under Construction.

for the Victor products, have become so frequent that it takes new buildings of more than usual size and importance to arouse particular interest. A new addition, the significance of which will be

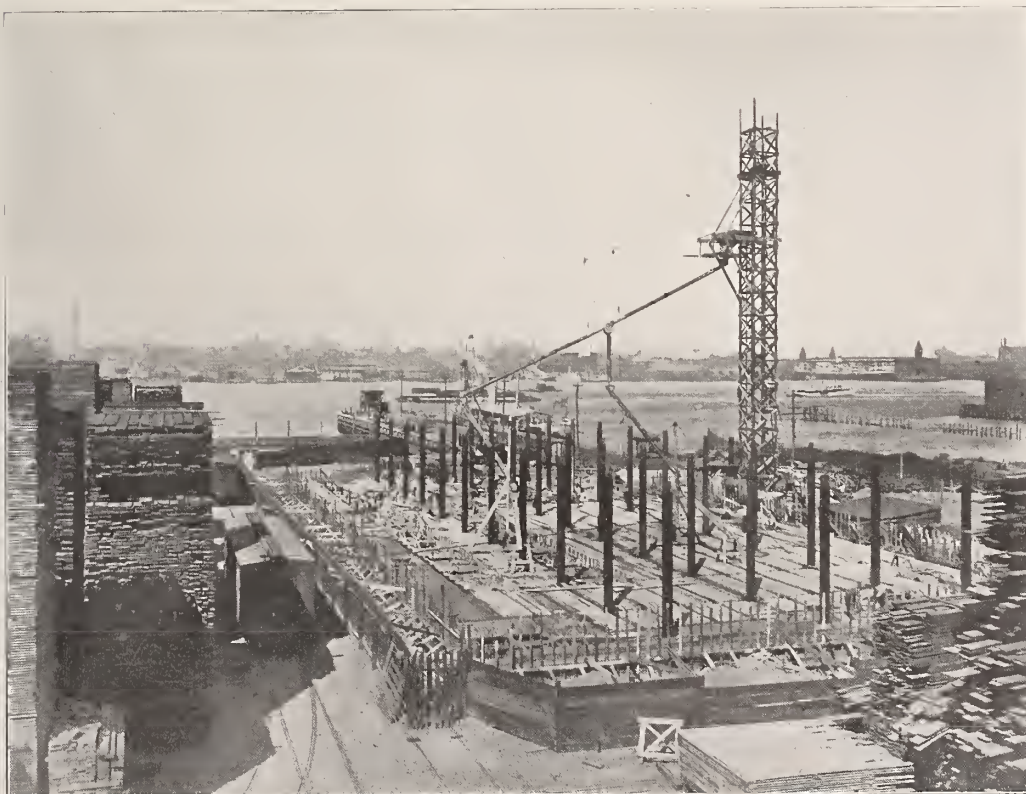

New Grinding Plant of Victor Talking Machine Co.

much appreciated by the trade, is the grinding plant being erected to provide for a great increase in record output. The accompanying illustration

10,000,000 gallon capacity for manufacturing purposes, and the main fire pump will have a capacity of 1,500 gallons per minute. Secondary pump will

also be provided with a capacity of 750 gallons per minute. Two of the furnaces in the fire plant will be equipped to burn sawdust and wood shavings from the cabinet factory.

TALKING MACHINE MEN MEET.

Executive Committee of the Eastern Talking Machine Dealers' Association Discuss Plans for Changing Name and Widening Scope of That Organization—General Meeting Soon.

The executive committee of the Eastern Talking Machine Dealers' Association held a special meeting late last month at the office of J. G. Bremner, the president, at 187 Broadway, New York, for the purpose of mapping out an active fall campaign for the association. Another meeting of the executive committee will be held shortly, at which time a date will be set for a general meeting of the association.

As a result of numerous discussions it is probable that the name of the association will be changed and the scope of its activities broadened within the very near future. It is the consensus of opinion that the association should accept as members men connected with every department of the talking machine business in New York and vicinity, whether jobbers, dealers or salesmen, with various classes of membership to take care of the different branches of the trade, if desired. It is believed that, by taking in representatives of different branches of the trade, the scope of usefulness of the association may be materially extended and a great number of important matters handled.

The change in the organization of the association was discussed at length at the meeting of the executive committee, but no definite action will be taken in the matter until the general meeting of that body about the middle of November. Of the new names suggested for the association that of "The Talking Machine Men of New York" is most favored as indicating the scope of the body.

The employment bureau of the association is now in full working order, and dealers desiring salesmen or other assistants, and salesmen and others desiring positions are requested to communicate with President Bremner, communications being held confidential.

Dealers not now members of the association are urged to file their applications before the call for the general meeting in order to be able to attend that session.

Percy A. R. Dow, of San Francisco, the noted vocal teacher, is a great admirer of the talking machine, which he uses in conjunction with his teaching.

OUR
VICTOR SERVICE
IS SAFE
PROMPT
EFFICIENT

We safeguard our patrons' every interest. Try us next time. Mail orders receive prompt attention.

ELMIRA ARMS CO.
117 MAIN ST., ELMIRA, N. Y.

THE TRADE IN NEW YORK CITY AND VICINITY

The past month in local talking machine circles has been characterized by a shortage in machines and records, which bids fair to become more marked during the next three weeks. Although the factories are working to full capacities in all departments, they have been unable to supply the demands of their trade, and present indications point to this shortage extending to practically all classes of records, and the majority of machines.

At the present time, the machine shortage is being confined principally to the medium priced machines, retailing at \$75 and \$100, but this was to be expected, in view of the fact that these machines have been the best sellers since the first of the year in all parts of the country. The record shortage is more general, including popular and semi-classic selections in addition to an ever increasing shortage of dance records. The dance craze, which was thought to be at its height this

summer, is still growing, and with the advent of cold weather, there is a demand for dance music for home gatherings which is producing a most profitable trade for the live-wire dealer.

Judging from the reports submitted by local jobbers and dealers, there has been an unusually heavy trade the past month in foreign records. Those dealers who carry representative stocks of these records state that they are adding new names to their customers' lists with surprising regularity, and that it is a class of trade which is certain to assume still greater proportions. When the present European war started this summer, the foreign record trade showed a marked depression, due probably to the unsettled conditions existing in foreign quarters throughout the country. The second month of the war, however, witnessed a revival of interest in foreign record production which has steadily increased, culminating last

month in the closing of a local foreign record business that in many instances exceeded that of last December.

Utilizing Publicity.

Local advertising of talking machines and records has been unusually active the past month, and it is significant that the bulk of this publicity has been devoted to the medium and high-priced machines with very little reference to the cheaper models. That this advertising has produced satisfactory results is evidenced by the fact that a number of the advertisers have increased their space each week, and added to the lists of newspapers they have been using. Several lists of records were also featured prominently in this advertising, and these lists acted as valuable suggestions for prospective record purchasers.

The talking machine trade as a whole has been excellent the past month, and far better than kindred retail lines. Business conditions in New York have not yet recovered from the recent stagnation in financial circles, and it is rare indeed that any trade can boast locally of a gain over the fall months of 1913. That the talking machine industry is enjoying a season of prosperity and banner sales may be attributed to a considerable measure to the optimism of the manufacturers and their willingness to spend huge sums of money for publicity in the face of retrenchment in all other lines. The stability and strength of this industry is well illustrated by this year's business, which will undoubtedly break all previous records, despite the handicaps surrounding commercial activity in certain parts of the country.

J. Newcomb Blackman at the Helm.

J. Newcomb Blackman, president of the Blackman Talking Machine Co., 97 Chambers street, Victor and Edison cylinder distributor, and one of the most popular men in the local trade, returned to his desk the first of the month after an enforced absence of ten weeks, occasioned by a serious attack of typhoid fever. Mr. Blackman spent a week convalescing at Atlantic City, and returned to his office imbued with energy and vigor for the fall campaign. In a chat with *The World*, he stated that October business showed a nice increase over that of October, 1913. Blackman dealers report a heavy demand for the Victrolas retailing at \$75 and \$100 and have placed large orders for these machines. During the past few weeks, this company has prepared a series of signs for window display, embodying distinctive features which should make them of considerable value to Victor dealers. These signs feature various types of records, including the popular fox-trot selections, the Victor records for the Castle Gavotte and similar timely topics.

Thirty Per Cent. Increase for October.

"Our sales totals for last month showed a 30 per cent. increase over those of last October," said R. F. Bolton, manager of the wholesale headquarters of the Columbia Graphophone Co., 89 Chambers street, New York, "and our business this month has started with a larger number of advance orders than ever before. Last year was a record breaker, but every month this year has run ahead of the corresponding month of 1913, so that we have no cause for complaint. There is every indication of a decided shortage next month, and we have suggested to our dealers that they anticipate their record requirements as much as possible, in order that they may not lose any sales during the holiday season. All of our machines have been ready sellers the past month, but our new 'Leader' and 'Mignonette' with the individual record ejector are specially worthy of mention. Collections have been remarkably good since October 1, and taken as a whole, this important division of our business is very satisfactory."

Tells of Business Growth.

Referring to Edison disc progress in their territory, A. W. Toennies, of the Eclipse Phonograph Co., 203 Washington street, Hoboken, N. J., ex-

(Continued on page 26.)

Why Don't You

Use

Bruno Service?

Victor Distributors

WHOLESALE ONLY

¶ An adequate stock, complete and modern equipment and a superior organization, make it possible for us to serve you well.

¶ That is our aim.

¶ May we have the opportunity?

C. Bruno & Son, Inc.

ESTABLISHED 1834

Victor Talking Machines Musical Instruments

351-353 FOURTH AVE., NEW YORK

IS YOUR JUDGMENT CORRECT?



Are You Looking Just a Little
Ahead in Order to Bag the Game?

Remember

¶ You are in the beginning of the Holiday Rush,

You Will Need The Goods

¶ You will appreciate the peace of mind of depending upon us — Our Service.

The World's Largest Distributor

NEW YORK TALKING MACHINE COMPANY

81 Chambers Street : : : : : : : New York

THE TRADE IN NEW YORK CITY—(Continued from page 24).

clusive Edison distributors, remarked as follows: "The appreciation of the Edison disc product in the minds of the trade and music-lovers through this state is growing rapidly, and the new Edison disc records are being praised by all who hear them. Our dealers are well pleased with the record distribution plan inaugurated recently by the Edison factory, whereby new records are received weekly. This constant issuance of new selections enables the dealers to offer their trade the very latest of all classes of music, and permits of the development of a most profitable record business. Edison disc phonographs of the \$200 and \$250 types are by far the best sellers in our line, and the Edison disc dealers that we signed up during the past few months report the closing of an excellent fall business."

How the Dealer Is Helped.

V. W. Moody, sales manager of the New York Talking Machine Co., 81 Chambers street, New York Victor distributor, announced to the trade last week the completion of a new code to record-stock flag system that contains numerous practical features which aim to improve the dealer's record business. This company has in the past issued various co-operative plans for the development of their dealers' business, and the success of these plans is well evidenced in the voluminous file of unsolicited letters of praise which Mr. Moody has received from appreciative Victor dealers. The latest plan has been in course of preparation for some time, but was held up because of the inability to secure the necessary labels. The system involves the use of nine colored labels, each representing a certain class of music, in small size and a foreign language in the large size, as for example, black signifies bands and German or Ruthenian. It is almost impossible to be mistaken with the foreign language labels, as the dealer catering to German trade will hardly carry Ruthenian records and vice versa. Mr. Moody has advised the trade that the New York Talking Machine Co. has arranged for the manufacture of the colored labels,

which will be practically furnished the dealer at cost. The advantages of this system, used in conjunction with the company's stock system, are many, and at once apparent to the dealer who appreciates the value of being able to know at first hand the deadwood in his record stock, the best sellers, etc. The proper use of this system will save the dealer and customer valuable time, and by enabling him to balance his record sales properly will increase the efficiency of the dealer's record department.

Establish Many Dealers in New York.

Although the Pathé Frères Phonograph Co. only made its announcement to the trade a few weeks ago, it has already established quite a number of dealers in New York and the adjacent territory, and has applications on hand for many more dealer licenses. The quality of the products manufactured by the company are generally recognized, and the many models of the Pathephone are scoring a signal success. Pathé discs, which include every class of music now on the market, are winning approval from all of the company's dealers, and the records for dance purposes in particular, which were recorded under the supervision of Maurice and Florence Walton, have achieved noteworthy success.

Made Tremendous Hit.

When the Columbia Graphophone Co. issued last month "It's a Long, Long Way to Tipperary," it felt that this record would serve as a timely reminder to many patriotic sons of Great Britain in this country, but it was not quite ready for the tremendous ovation that was accorded this record when it made its appearance on the market. Hayward Cleveland, manager of the Columbia department at the F. G. Smith store, 335 Fifth avenue, and one of the pioneers of the retail trade, states that he has never seen a record which achieved the instantaneous fame of the "Tipperary" selection. All of the Columbia representatives in New York affirm that this record is the best seller in the catalog at the present time, and is in demand

because of its patriotic significance and true musical value.

Open Fifth Landay Store.

Landay Bros., the prominent Victor distributors, will open this week their fifth exclusive Victor store, which will be located at 23 West Forty-second street, in the heart of the high-grade shopping district, and directly facing the New York public library. The illuminating system for this store will be especially beautiful, and the artistic character of the decorations may be summed by pointing out that this store will surpass in this direction all of the other Landay stores, which are recognized throughout the trade as being models of modern perfection in the display of Victor products.

Many Visitors to Edison Shop.

The Edison Shop at 473 Fifth avenue, the opening of which is noted in detail in another part of this issue, is proving to be the Mecca of music lovers from far and near, and the daily gatherings in the recital hall average about a thousand people, which is a remarkable attendance for informal recitals of this character. The sales staff at this store, comprising P. C. Sweeny, Raymond Duncan and Edward Levin, are being kept busy from early morning until closing time, and the favorable impression left by the concerts is indicated by the substantial sales which are being closed regularly day by day.

Increasing Its Wholesale Business.

Under the capable management of Thomas F. Green, the Silas F. Pearsall Co., 18 West Forty-sixth street, Victor distributor, is rapidly increasing its wholesale business. New accounts are being signed up regularly, and these additions to the Pearsall clientele are not only located in Greater New York, but in the surrounding territory as well. Thoroughly conversant with every detail of Victor merchandising, Mr. Green is extending valuable and practical co-operation to the many Pearsall dealers.

The advice "follow the natural bent" doesn't mean for you to be "crooked."

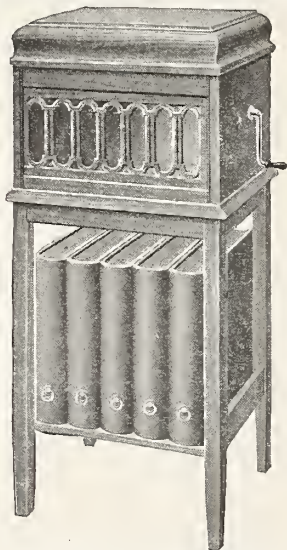

Style "Jewel" Combination
Price \$40 (Album Extra)

Sells in Preference When Heard in Comparison

11/15/14

Such goods not only *sell* but *satisfy*, and *satisfied customers tell others*. The Sonora sells itself in comparison with every other style of phonograph.

The Sonora gives continual satisfaction because of the great superiority of

1. THE TONE PRODUCING FACTORS
2. ITS NOISELESS-SOLIDLY-BUILT-UP MOTOR
3. ITS ARTISTIC DESIGN AND FINISH AS AN ARTICLE OF FURNITURE
4. ITS ABILITY TO PLAY ALL MAKES OF DISC RECORDS PERFECTLY
—THE DIAMOND, THE SAPPHIRE AND THE STEEL NEEDLE

SONORA

"The Highest Class Talking Machine in the World"

A Line that Wins at Every Point with a Price for Every Purse

The Sonora Phonograph offers the dealer a line of quality instruments at a price to meet every demand from \$35 to \$200. Our dealer arrangements are broad and liberal. We solicit reliable representation for protected territories.

The Sonora Jewel Multi-playing Needle, Price \$1.00

This needle revolutionizes record playing. It fits any make machine and plays all makes of steel needle or lateral cut records hundreds of times without changing. It preserves the life of the record, improves the tone quality, minimizes needle scratch, eliminates the inconvenience of needle changing and gives regulation of tone volume without extra accessories. Every needle guaranteed three months. We already have scores of dealers making profits on this needle. Ask us for details.

Selected Territories Still Open. Write for Your Opportunity.



Style Grand. Price \$200

Sonora Phonograph Corporation
57 Reade Street, New York Geo. E. Brightson, Pres.

HOLIDAY TRADE DEVELOPING IN MILWAUKEE.

Heavy Demand Reported for Both Machines and Records—A. G. Kunde Opens New Store—Other New Concerns Enter the Field—Live Advertising Campaigns the Rule—Placing Talking Machines in Schools—Gensch-Smith Co. Expands—News of Month.

(Special to The Talking Machine World.)

MILWAUKEE, WIS., November 10.—Indications are that the holiday trade is beginning to open up, especially about the State, even at this early date. Jobbers for all the leading lines of talking machines say that they are being rushed with business as a result of the action of dealers in preparing for the holiday rush. Conditions about Wisconsin are somewhat more favorable than in the city of Milwaukee, and it is probably only natural that the talking machine business is more active than here in the city. The situation locally is showing steady improvement, however, and jobbers and retailers anticipate that total business will average up satisfactorily.

"The demand from Victor dealers all over the State for both machines and records is unusually good and it is requiring every possible effort to fill orders," said S. W. Goldsmith, vice-president of the Badger Talking Machine Co., jobber for the Victor line. "We have established several new Victor dealers during the past month. Business at the Badger Victrola shop, the retail branch of our concern, is showing steady improvement."

Probably one of the main reasons for the better trade about State is the fact that crops have been exceptionally good this season. There is really plenty of money in this section of the Northwest, the only problem being to prevent people from hoarding all of it. The Wisconsin crop report for October, recently issued by James C. MacKenzie, secretary of the State Board of Agriculture, shows that crops were satisfactory in all lines. The yield of corn, most lines of grain and in tobacco was the largest in recent years.

Kunde Opens New Store.

The handsome new store of A. G. Kunde, Columbia jobber and retailer at 516 Grand avenue, located in the new Miller building at Grand avenue and Fifth street, was opened to the Milwaukee trade during the latter part of October. The establishment is without doubt one of the finest of its kind in Milwaukee and offers an appropriate setting for the Columbia goods. There are twelve sound-proof booths in the store, eight being located on the first floor and four in the basement, where the foreign records are demonstrated. A feature of all the booths is the fact that they are ventilated thoroughly, each booth being equipped with a modern ventilating system, so arranged that the air is changed constantly. The general color scheme followed in the store is brown, even the furnishings conforming to this color. The window display facilities are ample, and Mr. Kunde is making good use of the opportunities in this line. It is possible that a formal opening of the new establishment will be held within the near future. Business has been so good since the opening of the store that Columbia sales have been climbing to a new high point.

Charles F. Baer, manager of the Columbia business in Chicago, accompanied by Mrs. Baer and W. W. Pearsons, manager of the Dictaphone department in Chicago, motored to Milwaukee recently and were the guests of Mr. and Mrs. A. G. Kunde at the new Columbia store.

Help "Buy-a-Bale" Movement.

One of the few bales of cotton to appear in Milwaukee as a result of the "Buy-a-Bale" movement to help the South, was purchased by S. W. Goldsmith, vice-president of the Badger Talking Machine Co., Victor jobber. The bale has been placed in the windows of the Badger Victrola Shop, where it is attracting much attention.

Large Victrola Sales.

Victrola sales at the Edmund Gram Piano House have been climbing to a new high mark of late, due to the fact that Paul A. Seeger, manager of the Victor department, has been given exclusive use of one of the Gram automobiles, with which he is calling on the trade.

Open New Department.

Another new Victrola department was opened

in Milwaukee on October 26, when Edward Schuster & Co. threw open its third new department store. The new establishment is located on the south side at Mitchell street and Sixth avenue, and has been meeting with a big business since the opening. The Schuster concern carries the Victor line at its other two department stores and naturally installed the same line at its new store. M. Marks, who is in general charge of the piano and Victor departments at the other two Schuster establishments, has the management of similar departments at the south side store.

New Edison Dealers Appointed.

The Edison business in Milwaukee has been showing decided increase of late, according to the record attained at all the local stores. The Edison Shop, the retail branch of the Phonograph Co., of Milwaukee, C. Niss & Sons, the George Eichholz Co., the Flanner-Hafsoos Music House and Charles H. Scheff & Sons have all been meeting with an increase in trade, especially in the higher priced machines. William A. Schmidt, general manager of the Phonograph Co., of Milwaukee, reports the locating of several new Edison dealers in Wisconsin and Upper Michigan, among them the Hook Bros. Piano Co., of Madison, the capitol city of Wisconsin. Hook Bros. have arranged new and special quarters for the Edison line.

In Charge of Retail Sales.

Gustave A. Schultz, formerly connected with some of the leading piano houses in Milwaukee, has been placed in charge of retail sales at the Edison Shop, 213-215 Second street, the retail branch of the Phonograph Co., of Milwaukee. Mr. Schultz was at one time manager of the talking machine department of the old Rohlfing Music House and is well prepared to fill his new position. William Idle, traveling representative of Thomas A. Edison, Inc., in Wisconsin and Upper Michigan, has been spending some time in his Michigan territory of late.

Reports Growth of State Business.

Harry R. Fitzpatrick, traveling representative of the Victor Talking Machine Co. in Wisconsin, northern Michigan and northern Illinois, reports that general business conditions are showing decided improvement and that dealers are buying more freely. Mr. Fitzpatrick makes his headquarters in Milwaukee.

Takes Over Agency.

News has been received from Waukesha, Wis., that the Victor agency and stock of A. S. Putney, Jr., located at 506 Grand avenue, has been taken over by the Waukesha Victrola Shop.

Advertising Brings Results.

Milwaukee's two leading downtown department stores which carry the Victor line, Gimbel Bros. and the Boston Store, have been meeting with a big business of late, partly as a result of the consistent advertising carried on by both. L. C. Parker, enterprising manager of the Gimbel Victor department, reports that Victor sales made substantial gains during October. Carl W. Abbott, in charge of the Boston department, has increased his force and is making some fine sales.

Display for Benefit of Teachers.

It is safe to say that the teachers of the State are now thoroughly familiar with the Columbia line as a result of A. G. Kunde, Columbia jobber and dealer of Milwaukee, featuring three types of Columbia machines at the annual convention of the Wisconsin State Teachers' Association, held at the Milwaukee Auditorium, November 5, 6 and 7. Mr. Kunde had one large machine on the platform, which was made good use of during the sessions, and two other machines located in the lounging rooms. R. G. Winters, Chicago, manager of the educational department of the Columbia Phonograph Co., was here in Milwaukee to assist Mr. Kunde in the demonstration work.

Enlarges Quarters.

The Gensch-Smith Co. has been finding business so good that it has been forced to enlarge its quarters and has secured a space 16 x 20 feet in dimensions adjoining its present store. The company sold Style XI Victrolas to the Carlton Hotel and the Layton school of Milwaukee last month.

Talking Machine in the Schools.

That the teacher of a rural school should by all means secure a Victrola for her pupils, even if she has to go out and borrow one from some family in her district, was the contention of Miss Delia E. Kibbe, Chippewa Falls, Wis., who spoke on "Music in the Rural Schools" before the recent annual convention of the Northwestern Wisconsin Teachers' Association, held at Eau Claire. Miss Kibbe recommended the use of mechanical instruments in every grade in the rural schools as a means of teaching appreciation of music, and urged the teacher to secure a Victrola at any cost. She suggested the greatest care in the selection of records, and laid particular emphasis on the necessity of the country school teacher realizing the importance of musical work, because of the influence it would have upon the pupils.

LONG CABINETS

A NEW PATTERN FOR 1914-15



D70

FOR VICTROLAS VIII, and IX.
Mahogany, Fumed Oak, G. O. and W. O.

New illustrated matter of the whole line will be cheerfully sent on request.

Kindly anticipate your requirements, naming dates for shipments.

The Geo. A. Long Cabinet Co.
Hanover, Pa.

Address Clement Beecroft, Sales Manager
309 W. Susquehanna Avenue, Philadelphia



The PATHEPHONE

and Pathé Double Disc Records

THE MACHINES:

Beautiful in appearance, and the result of the combined talent and experience of the Pathé Frères vast establishments in Paris, Berlin, London, Petrograd and Vienna.

Our largest model machine will be equipped by us to play every make of Disc Record on the market, and play it perfectly.

Our goods are sold under our own patents, applied patents and copyrights, or under arrangement of patents held by others, so that any dealer can handle our goods without fear of intimidation or law suit.

The Pathephone, as to mechanism, acoustics and style, is the best on the market. We make this statement unqualifiedly.

**Bigger Volume!
Better Tone!**

Played with a permanent round sapphire instead of a needle.

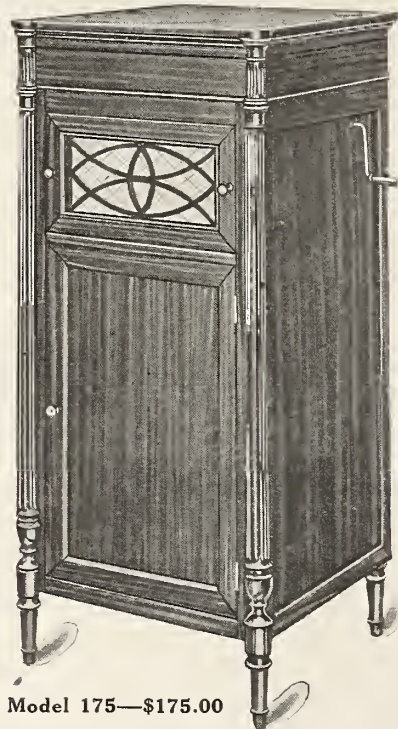

Model 175—\$175.00

THE RECORDS:

Sweet in tone—true to nature—rich in quality—full in volume. Many thousands of selections—Bands, Orchestras, Vocal and Instrumental, Opera Stars, Popular Singers, Dance Music, etc.

We claim and will demonstrate that the Pathé Discs (all double) are superior to anything on this market. They are made by the up-and-down cut system of recording.

We are now ready to receive the applications of jobbers and dealers and solicit your visit and correspondence.

SIZES AND PRICES OF DOUBLE RECORDS:

11 1/2-inch	. . .	\$.75 to \$2.00
14 "	. . .	1.25 " 2.50
20 "	. . .	4.00



Model 15—\$15.00

Latest Selection of
OPERA DISCS
Music on Both Sides
Catalogs Ready

DANCE DISCS
Endorsed by
Maurice and Florence Walton



Model 50—\$50.00

PATHÉ FRÈRES PHONOGRAPH CO.
29-33 WEST 38th STREET
NEW YORK

AN EFFECTIVE WINDOW DISPLAY OF VICTOR MACHINES.

(Special to The Talking Machine World.)

LANSING, MICH., November 9.—The accompan-



ing illustration shows the work of Max Wenzel, manager of the talking machine department in the large furniture store of M. J. & B. M. Buck of this city. Mr. Wenzel has shown a decided

aptitude not only for display window work of the better sort but also for the arrangement and conduct of the department itself. Mr. Wenzel has vastly increased the business of his section and supervised and recently made a large number of improvements and alterations designed to care for an ever-increasing patronage.

Mr. Wenzel is very friendly with George P. Cheate, traveling sales manager of the Talking Machine Co., of Chicago, and while the latter was in Lansing recently the two discussed plans for additional betterment of the department work. Mr. Cheate reports an excellent business all through this section of Michigan.

of dance records, which has been stimulated also by the large advertisement, almost a two-page spread in a local newspaper, in which the local Columbia houses have joined in advertising such records. If anything, the dance records are eclipsing the last year's record, which was considered phenomenal.

Mr. Salmon, of the wholesale department, reports a steady betterment of jobbing conditions, and he says that local dealers are buying freely in anticipation of a good winter's business on the strength of the improvement they have seen in local conditions. The orders from the country, too, are reported on the up-grade.

The Silverstone Music Co. is quite proud of two recent additions to the list of local Edison disc dealers, which has a total of fifteen in this city and environs. One of these two is the Kunkel Bros. Music Co., of which Prof. Charles Kunkel is the leading spirit.

The other addition to the list is the Royal Music House, of 5906 Delmar avenue, opened by Roy L. Wilson, recently an executive of the Banner Buggy Co., a flourishing institution of this city.

Some recent visitors to the Silverstone Music Co. include: J. W. Milligan, Carbondale, Ill.; W. H. Day, manager C. W. Best & Sons, Fredericktown, Mo., and J. H. Bennett, of Sullivan, Mo., who is selling machines in the Ozark Mountains on the old sewing machine wagon plan and who is making a success of it.

A. H. Reynolds, of the Silverstone Music Co., is making a Southern tour.

ACTIVITY REPORTED IN ST. LOUIS.

Jobbers and Dealers Make Excellent Reports—Koerber-Brenner's Expanding Trade—Higher Priced Outfits Have the Call—New Edison Dealers—No Pessimism at Columbia Co.—Recent Visitors to the Sainly City.

(Special to The Talking Machine World.)

St. Louis, Mo., November 9.—All of the local jobbers assert increases over last year and stand ready to show monthly totals. With the retailers the situation is slightly different. All are doing more business, apparently, than dealers in other lines, and those who cater chiefly to the high-priced trade, from \$75 a machine and up, are beating last year's sales records. Those who sell chiefly lower-priced machines are finding the sledging a bit hard, but, as outstanding monthly collections are improving rapidly, they expect the sales business to pick up as soon as the wage earners are again returning to hours that leave a margin for some luxuries.

B. B. Taylor, for five years with the Victor factory sales force and recently located in Illinois for that company, has joined the sales staff of the Koerber-Brenner Music Co., of this city, and will travel in Missouri, Illinois and Indiana in the interests of the Victor line, which now is handled to the exclusion of all other music goods by the Koerber-Brenner Co.

E. C. Rauth, secretary of the Koerber-Brenner Co., says that their trade is excellent and totals are showing a marked increase over last year's sales. This company has experienced a little show of dull trade in most of their rural territory, although some parts of the South have been slow in placing orders. In the grain country the talking machine dealers are ordering freely, feeling sure that the people will buy when they sell their grain, which is slow going to market this year because of a natural desire on the part of the farmer to share in the war prices, which all believe are bound to come.

Manager Robinson of the Thiebes Piano Co. talking machine department reports an improving trade, and he continues to dwell on the opportunity to compare the three leading makes of machines at the demonstration rooms of that company. Mr. Robinson has added to his sales staff L. B. Prince, formerly with the Thiebes Co., but recently working in the East, and R. G. Shelp, recently with the talking machine department of the Vandervoort Music Salon.

Aeolian Hall is now selling Columbias and is meeting with good success. The additional space recently gained for the retail department through the first floor demonstration rooms has been appreciated of late.

Manager Irby Reid, of the Columbia warerooms, is very proud of the feat of his eight-year-old daughter Dorothy, who has sold a Columbia machine to her school in Webster Groves, a suburb.

At the Columbia warerooms there is a positive

rule against pessimism. Everybody there must be optimistic, and visitors who would be treated courteously must express similar views. As a consequence business is going ahead nicely.

Business with the dancing teachers and dance halls has resulted in an extraordinary sale

**A
BLACKMAN
TIP**

**"SATISFACTION AT BLACKMAN'S
COSTS NO MORE
THAN
DISSATISFACTION ELSEWHERE"
(BLACKMAN)**

If you are PARTICULAR about service and MUST HAVE
THE GOODS on time—there is ONE SAFE PLAN
MAKE BLACKMAN YOUR JOBBER

BLACKMAN TALKING MACHINE CO.

**J. NEWCOMB BLACKMAN, Pres.
97 CHAMBERS ST., NEW YORK
VICTOR and EDISON Distributors**



THE CENTURY

A Distinct Innovation in Talking Machines

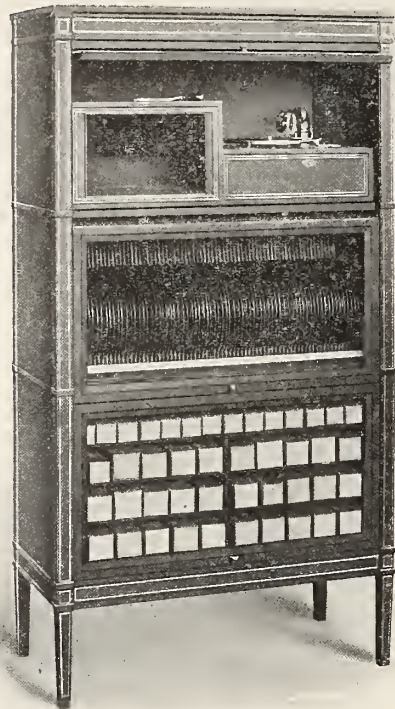

CENTURY

CENTURY

Examine the illustration shown above, and see if such a talking machine will not fit perfectly into your business.

These instruments are produced by a corporation which, for years, has had a well established and successful business, and it will be seen that the Century Cabinets will harmonize perfectly with library or drawing room furniture.

They are being made in four styles, including the Chippendale, Sheraton, Colonial and Artcraft, each style true to the period which it represents. They retail at \$150 and \$200.

A feature of these instruments is that **they will play any record on the market.** To do this requires but an instant adjustment, changing the position of the sound box and the insertion of a needle or jewel point. No separate attachment is necessary for the different types of record.

Dealers will see at once what trade possibilities are open to them with this new line.

In the illustration is shown a Cabinet in the Sheraton style. Units for storing music rolls are interchangeable with units for disc records. The method of filing and indexing records is the most flexible and efficient yet offered.

All who have listened to the Century have been enthusiastic in their predictions for it. The musical qualities are remarkably clear and pure, and the overtones of the different instruments are brought out with surprising effect.

As a musical instrument, the Century is destined to immediately win high rank.

Recollect, the Century is not an experiment. It has been perfected by the manufacturers, who feel that in inviting attention to the Century phonograph they are offering a product which will be approved by the talking machine trade.

Behind the Century stands a complete organization which is in a position to cater to the increasing demands of the talking machine trade.

For full particulars address

CENTURY

The Century Cabinet Co.

CENTURY

1182 BROADWAY

NEW YORK CITY

GEO. W. LYLE REVIEWS CONDITIONS.

Vice-President of Columbia Graphophone Co.
Very Optimistic Regarding the Business Situation Upon Return from Transcontinental Trip—Some Recent Important Columbia Connections Throughout the Country.

"Although general business conditions throughout the country are not of the best," says George W. Lyle, vice-president of the Columbia Graphophone Co., New York, who returned last week from an extended trip to the Coast, "there seems to be a much more optimistic feeling prevailing, and now that business is adapting itself to the European war conditions, trade in all lines seems to be improving steadily.

"Columbia business, notwithstanding these unsettled conditions, was never in better shape than

POSITION WANTED

By a highly educated young married man who has had eight years' experience as a talking machine store manager. Am thoroughly familiar with Victor and Columbia product and know how to build up your business. Would not object to going to a small, good city. Address "W. A.," care The Talking Machine World, 373 Fourth Ave., New York City.

PARTNER OR MANAGER WANTED

Wanted for my branch store, 246 Huntington Ave., Boston. This establishment is located in the very heart of the musical center. I want a man who understands the Talking Machine business thoroughly and can produce results. This is a splendid opportunity for the right man. Rosen's Talking Machine Shops, 3 School St., Boston, Mass.

AN UNUSUAL OPPORTUNITY

In order to take care of its rapid growth of business a Talking Machine Company (operating under Victor contract), with excellent references, show room and equipment, doing a very successful business, with a most favorable lease, finds it necessary to increase its capital stock by \$20,000. It would be pleased to correspond with one who can take an active part and furnish additional capital. If you mean business, can qualify and take active part, give a few particulars and an interview will be arranged for. Address "Finance," care The Talking Machine World, 373 Fourth Ave., New York City.

WANTED

Business partner in an established Talking Machine Company selling Victor and Edison machines. Best of references required and given. Address Smith, care The Talking Machine World, 373 Fourth Ave., New York City.

WANTED FOR CASH

Wanted to buy job lot of disc Talking Machines and records. Will pay cash. Address "Cash," care The Talking Machine World, 373 Fourth Ave., New York City.

AN OPPORTUNITY

Capitalist and business man wanted (or for sale) to handle patented invention (not an attachment), but consisting of an entirely new PHONOGRAPH TELEPHONE, etc., etc., instrument which eliminates all distortion of form or quality, superior to any known method on the market. The correct recording, reproducing and transmission of music at last made possible. Your business and financial responsibility a first requirement. For further particulars address Palys L. Chevrier, 1910 Hillcrest Road, Hollywood, California.

FOR SALE

1,500 brand new double-faced 10-inch records, mostly band selections. Must be sold at once at 20 cents each. Address The German Phonograph Co., 275 South Fifth street, Brooklyn, N. Y.

WANTED

An experienced Talking Machine saleswoman. Apply by letter only. Globe Talking Machine Co., 9 West 23d St., New York City.

at present, and this is evidenced in the fact that our sales totals this year show a substantial margin over those of 1913, our previous banner year. Internationally prominent concerns are arranging to handle Columbia product, and the high standing of many of the new accounts we have closed the past few months indicates a movement towards Columbia goods more pronounced than at any time in the history of the company. Marshall Field & Co., the Aeolian Co., the New England Furniture & Carpet Co., and the Denver Music Co. are all concerns whose prestige is country-wide, and recognized in all trade circles."

While on the Pacific Coast, Mr. Lyle made arrangements with a manufacturer of talking machine cabinets, it being the intention of the Columbia Co. to have manufactured on the Coast a large portion of their cabinets for the far Western trade, providing suitable quality of product can be assured.

Mr. Lyle states that the new Columbia Grafonola "Leader" with the individual record ejector, an exclusive Columbia feature, has met with a most pronounced success, and while this has been announced and advertised but once or twice, orders have been placed for over five carloads of the special record interiors and orders for this type of machine are over 1,500 in arrears.

While on this trip, Mr. Lyle attempted to make clear to the trade that the demand for Columbia product in this country was such that he feared there would be a greater shortage of machines than ever and that dealers must anticipate their requirements, placing their orders now so that they may protect themselves for the holiday business which is so close at hand.

OHIO ASSOCIATION ACTIVE.

The Northern Ohio Victor Association Considers Important Questions at Meetings, Including That of Sending Records Out on Approval and Price Cutting.

(Special to The Talking Machine World.)

CLEVELAND, O., November 7.—The Northern Ohio Victor Association, which was organized last January, has held several well-attended and very interesting meetings in this city during the last few months and discussed various questions of importance to the trade.

A question that has aroused much interest on the part of the association members is that of sending records on approval to the homes of machine owners. It is the consensus of opinion that records should be sent on approval only when the customer agrees to retain and pay for at least 50 per cent. of such records. It is probable that a rule to this effect will be put in force by the association at its next meeting. And it will also be provided that no records will be sent upon approval after they have been demonstrated in the warerooms.

The question of price cutting has also been a live topic of discussion in association circles, for in Cleveland, as in many other cities, there are always numerous reports of certain concerns indulging in price cutting. It is the intention of the association to investigate all such reports thoroughly and to take united action when the reports are found to be true.

NEW CRESCENT MACHINE MODELS.

Two Low Priced Machines Among Those Announced by the Crescent Talking Machine Co.—Play Both Styles of Records.

The Crescent Talking Machine Co., 99 Chambers street, New York, announces several new models of Crescent talking machines, among them being a model which retails at \$12.50 and one for \$15. The company also is advising the trade of its line of "Crescent" records, which will be vigorously exploited as the weeks go on. In connection with the models of Crescent machines, the company features the fact that a mere turn of the soundbox enables one to play both styles of records.

It's far easier to take things as they come than to chase after them when they've gone.

"It Pays to Advertise"

Our increased facilities for VICTOR service, advertised in the Talking Machine World, has brought us many new dealers.

At Your Service

Is not an empty slogan with us.

We can deliver the goods.

Send us the next order that your present jobber cannot fill.

Landay
BROS. INC.

VICTOR DISTRIBUTORS EXCLUSIVELY

**563 5th Avenue
NEW YORK**

A Columbia

Every Columbia dealer can complete

Make this "Christmas" season the most *profitable* you've ever known by helping your patrons make this the most *enjoyable* Christmas they've ever known. You can if you really go after the people who are being told this month, in every class of standard publication, about the Columbia Grafonola as the ideal Christmas gift, and who are being urged to come to you to see it and hear it. Your own good salesmanship can easily complete these sales already half made—you have the "proofs" right in your store—turn the buying interest we are creating into cash for yourself.

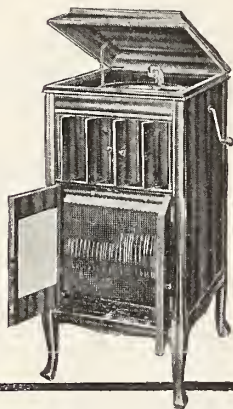

Show the new "Leader," with its distinctive and exclusive Columbia feature, the individual "record ejector." At its price, \$85 with the record ejector, \$75 with ordinary record racks, it is just such a musical instrument as will appeal to those who desire the appearance and solidity of the highest priced at a considerably lower cost. And not forgetting, of course, to emphasize its wonderful tone quality.



If your customer prefers to make his cost limit \$25, you can certainly show him wonderful value for his money in the "Eclipse." And when he understands that the difference between the "Eclipse" and the more expensive Columbias is one of degree—of tone volume, of such items as size, record compartments, covering lid, finish and motive power—he is pretty sure to realize that his \$25 is buying him a great deal of quality.

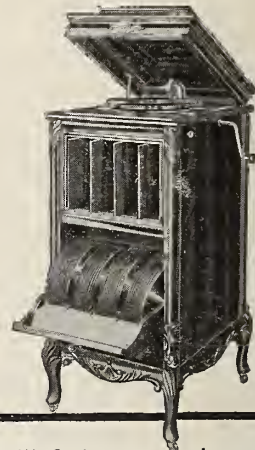

You will find many who want an instrument that most nearly approximates the "De Luxe" in size—but want to invest about half of its cost. These persons will find their ideal in the "Mignonette" at \$100. And when demonstrating the "Mignonette" you have an excellent opportunity to emphasize once more the superlative Columbia tone, so strikingly embodied in this model.

No matter what price limit may be set, every customer should surely see and hear the "De Luxe" at \$200. It is such a perfect demonstration of the finest achievement in cabinet instruments that it will convince him beyond argument of the superiority of the Columbia. And if price is secondary with him, it is the "De Luxe" he will buy.

And to those who have fixed \$50 as about what they want to spend, and expect to get in return almost every feature that any "talking machine" at any price can offer, show the "Favorite." You need hardly be told of the importance of the "Favorite" as a representative Columbia, or reminded how great the market has always been for this model.

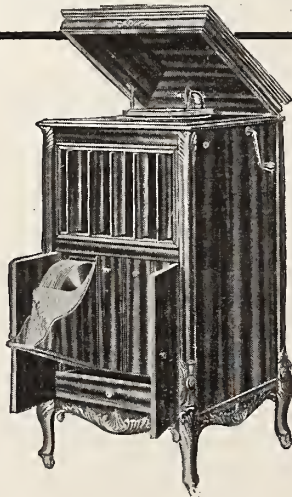

You will likewise have many callers who are convinced they want a Columbia, one that will play any and all music well, but who are not prepared to spend even as much as \$25. The "Meteor" enables you to give them just what they want—a real Columbia; and at the price, \$17.50, a wonderful demonstration of the continual fun and pleasure afforded by these ideal musical instruments. It makes a gift that is a real gift.

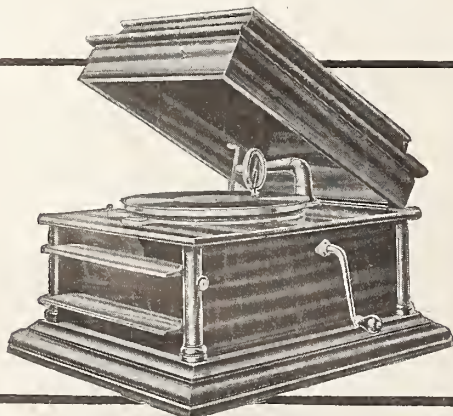

Whatever model of a Columbia Grafonola your customer finally decides to buy, you know he is buying a musical instrument that in tone, tone-control and in every refinement and feature making for perfection he is buying the best. And putting this enthusiasm into the selling means easy sales and many sales.

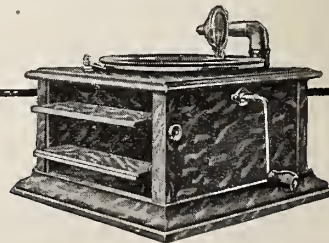

Make Up Record Suggestion Lists: Don't overlook the big profit possibilities that the Record sales hold. Make up lists of records, from a few at 65 cents each to complete assortments of every class of music. The Columbia Catalog makes this easy to do, and it means *money* for you. Remember, the purchase of a Columbia Grafonola for a gift will be all the more complete for an outfit of records. And your suggestion will carry weight with the person buying a machine, when it comes to buying the records to go with it.

Grafonola

many family circles Christmas Morning



It is the
Columbia Grafonola
that completes
the family circle.
Prices from
\$17.50 to \$500.



Columbia Graphophone Co.
Woolworth Building, New York

Dealers wanted where we
are not actively represented

CHRISTMAS
Gifts that are Substantial
 rather than mere trifles are yearly being bought by the majority of people. You should be able to promptly dispose of your share of record cabinets manufactured and advertised by
The Herzog Art Furniture Co.
 Saginaw, Mich.



CHRISTMAS
Gifts that are Appropriate
 to the season, especially music-gifts, are joyful investments. The Herzog Record Cabinets are appropriate gifts for Christmas, and many of them will be bought because they are so well advertised by
The Herzog Art Furniture Co.
 Saginaw, Mich.

Now Made in Two Grades— Grade "A"—Felt Interlining.
 Grade "B"—Cotton Interlining

Grade "A" is the highest quality cover made, with government Khaki and interlined with four layers of heavy felt. Grade "B" is also made of Khaki, but is interlined with cotton, this grade being made in response to a demand for a lower-priced cover. For lasting durability, however, Grade "A" is recommended.

LANSING KHAKI MOVING COVER

For Talking Machines



PHOTOGRAPH SHOWING LARGE LANSING COVER WITH NEW No. 3 STRAP.

We also announce our new No. 3 strap, which sells to the dealer at \$1 each. This is equipped with patent buckle (no teeth) and is made of 3-ply heavy webbing.

PRICES

- Grade A—Small Covers.. \$5.60
- Large " .. 8.50
- Complete with strap and patented buckle
- Grade B—Small Covers.. \$3.85
- Large " .. 6.00
- Complete with strap and patented buckle

E. H. Lansing
 611 Washington Street
BOSTON, MASS.

ORDER TO-DAY

One grade "B," large size, Lansing Khaki Cover, complete with No. 3 strap and patent buckle, \$6. Same for any small machine, \$3.85

COUPON

E. H. Lansing,
 Boston.
 Enclosed find \$.... for
 Khaki covers.
 Name
 Address



"Nonpareil" means "of unequalled excellence." And the country has plenty of proof that the Columbia Grafonola "Nonpareil" at \$150 was well named.



(Write for "Music Money," a book "full of meat" for those dealers interested in quick and frequent turnover of capital.)

**Columbia Graphophone Company
Woolworth Building, New York**

ENTERS TALKING MACHINE FIELD.

Century Cabinet Co. Ready to Introduce to the Trade the Century Phonograph and Record Filing Cabinet—Several Handsome Styles Prepared—Some Details Regarding the New Products and Their Distribution.

The Century Cabinet Co., 1182 Broadway, New York, one of this country's largest and most successful manufacturers of book cases and filing cabinets of all descriptions, has entered the talking machine field, after many months of preparation. The company has just placed on the market, and is now ready to deliver the Century phonograph and record filing cabinet which is composed of three units—a phonograph in one unit, and two record filing cabinets, or one record and one player roll cabinet, if desired.

According to present plans four styles of cabinets will be issued, the Chippendale and Sheraton styles to retail at \$200 each and the Colonial and Art Craft to retail at \$150. These styles are faithful reproductions of the periods they represent, and are finished in the same high-grade manner that has characterized the manufacture of the Century Cabinet Co.'s products in the book case and filing cabinet fields.

The phonograph which is contained in the top unit embodies certain new and perfected reproductive principles which were carefully tested and tried out at the company's factory in Utica, N. Y., and their musical value established before they were included in the completed phonograph. The Century phonograph is equipped to play any record on the market, without the use of any attachment whatsoever. By slightly changing the position of the sound-box and the insertion of a needle or jewel as may be desired, the phonograph is ready to play records cut laterally or on the hill and dale principle.

The Century phonograph and record filing cabinets are designed to harmonize completely with the furnishings of any room wherein they may be placed. The three units combine to make a most artistic piece of furniture, and additional units harmonizing in every detail with the original phonograph and cabinets will be furnished as needed.

The filing cabinets contained in the Century units embody a perfected method for the filing of records which makes for accessibility, safety and convenience. Each unit will contain 150 records of average thickness, or 75 thicker records. A patented principle termed a "rocker" permits of the instantaneous selection of a desired record without the necessity of holding aside the records not wanted.

The Century Cabinet Co. will market its products through the usual methods of talking machine distribution. The sale organization is rapidly nearing completion, and the excellent reproductive powers of the Century phonograph, the fact that it plays any make of record on the market without any extra attachment and the artistic appearance of the cabinet are some of the important sales arguments which will be presented.

The Century Cabinet Co. controls two large

factories at Utica, N. Y., and Fort Plain, N. Y., the former one now being given over in part to the manufacture of the Century phonograph and record filing cabinets. The company has furnished filing cabinets to the United States Government for many years, and is well known from coast to coast by reason of the success of its book cases, filing cabinets, etc.

NEW QUARTERS IN HOBOKEN.

Herman Jaffee Planning to Occupy Handsomely Equipped New Store in That City Later This Month—Handles the Victor Line.

Herman Jaffee, who for several years past has sold Victor talking machines and records at 122 Washington street, Hoboken, N. J., in connection with a stock of sporting goods and photographic supplies, has made arrangements to move to new and larger quarters at 118 Washington street shortly after November and as soon as the premises are remodeled to meet his requirements.

The new store will be equipped with four hand-

some sound proof booths having plate glass panels and being decorated with dainty carvings on the frames. The booths, as well as most of the woodwork in the store will be finished in ivory effect. On the opposite side of the store from the booths will be the record department and general machine showroom, also in ivory finish. The photographic and sporting goods departments will occupy considerable space in the front of the store.

Modern show windows with Mr. Jaffee's name, and the words Kodaks and Victrolas set above in leaded glass will insure the attractiveness of the new store from the front. A working sign using 500 electric light bulbs will also be a feature that will prevent anyone passing along Washington street from overlooking the new store.

The war in Europe has had a direct and bad effect on Hoboken's business owing to the fact that several large German steamship lines docking at that city have been forced to suspend service and lay off hundreds of sailors, longshoremen and other employes, but there is still business to be had by those who go after it.

The "OGDEN"

A Sectional Filing Cabinet and Sales System that—

- Saves time
- Saves money
- Saves space
- Cuts out dead stock
- Increases sales
- Fits your needs

and we are now prepared to make delivery on short notice. Fifty cabinets now on the floor and orders will be filled in order received—be the first to get yours in!

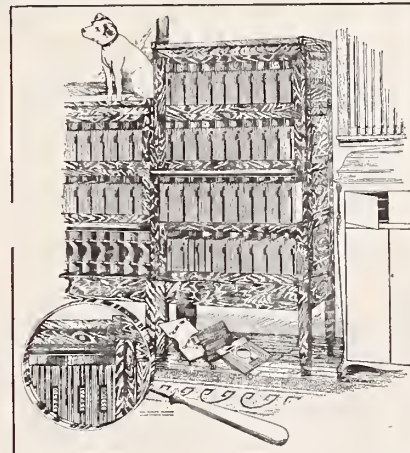

WORTH TEN TIMES ITS COST

This Sales System Envelope keeps track of what you sell and what you need—a perfect and automatic inventory, showing profitable and slow sellers. Envelopes arranged for upright or flat filing and will fit any system.

Ready For Delivery!

72,000 in stock. Immediate shipment made of all orders. Order direct, giving name of your distributor.

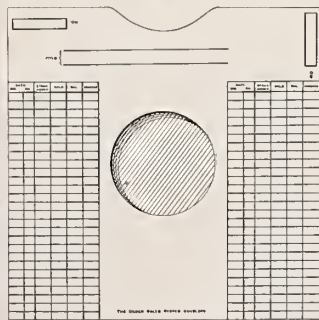

J. B. OGDEN
LYNCHBURG, VA.

NOW ASSISTANT SALES MANAGER.

Thomas J. Leonard Appointed to This Post by Thomas A. Edison, Inc.—Familiar with the Policies and Plans of This Big Organization.

The accompanying photograph presents Thomas J. Leonard, who a few months ago was appointed assistant sales manager of the phonograph department of Thomas A. Edison, Inc. Mr. Leonard has been connected with the Edison interests since 1895 and is thoroughly familiar with the policies and plans of this big organization. He was associated as assistant sales manager of the dictating machine department, as well as being connected with the auditing staff, and was in immediate charge of the house publications.

Previous to his coming with the Edison Co. Mr. Leonard was connected with the General Elec-



Thos. J. Leonard.

tric Co. and the American Locomotive Co. at Schenectady. He has also served his time as a newspaper reporter. So, with this training, there is no question but that the future holds excellent opportunities for the utilization of his ability.

OPTIMISTIC OVER OUTLOOK.

Discussing business conditions recently with Wm. K. Kaplan & Co., 316 Fulton street, Jamaica, N. Y., they stated that business for June, July and August showed an encouraging increase over the corresponding months of 1913, and that there was a falling off in trade for the month of September, due, no doubt, to local and general disturbing business conditions about this time. The outlook has improved materially, and Wm. Kaplan & Co. look forward to a very active holiday trade.

Two interesting interior views of the Kaplan warerooms have recently been sent out by this house, one showing the interior resources of the warerooms and the other showing a member of the firm at his desk in his office.

Your Opportunity

50 cents stamps brings you a sample of our highly perfected Standard Fibre Needle Cutter.
25 cents stamps brings you a sample of our simple and accurate Standard Automatic Stop.

Samples sent only to bona fide dealers writing on their business letterhead. Place regular orders through your jobber.

STANDARD GRAMAPHONE APPLIANCE CO.

173 LAFAYETTE STREET

NEW YORK

RECEIVES SOME STRONG PUBLICITY.

Pathescope Featured in Interesting and Effective Manner as One of the Prizes in the School Contest of the New York Tribune.

The Pathescope is being prominently featured in the New York Tribune, one of the leading local newspapers, in a special voting contest which is being introduced by that paper for the most popular schools in Greater New York. The schools are divided into classes and a total of twenty Pathescopes will be awarded to the leading schools.

In order that the many merits of the Pathescope may be adequately impressed on the minds of its readers the New York Tribune has been running half and full page advertisements in its paper calling attention to the educational and entertaining values of the Pathescope, and laying particular stress on the desirability of a school owning a Pathescope. These advertisements are forcefully presented and well illustrated, the accompanying cut of a Pathescope giving a fair idea of the careful consideration given the constructional features of the Pathescope in this publicity.

The Pathescope hardly needed any introduction to the New York public, as the splendid success it has achieved in exhibitions at the John Wanamaker auditorium has already won for it the approval and admiration of thousands of motion picture lovers. The recent introduction of the Pathescope as a perfected instrument for the display of motion pictures in the home was well cal-

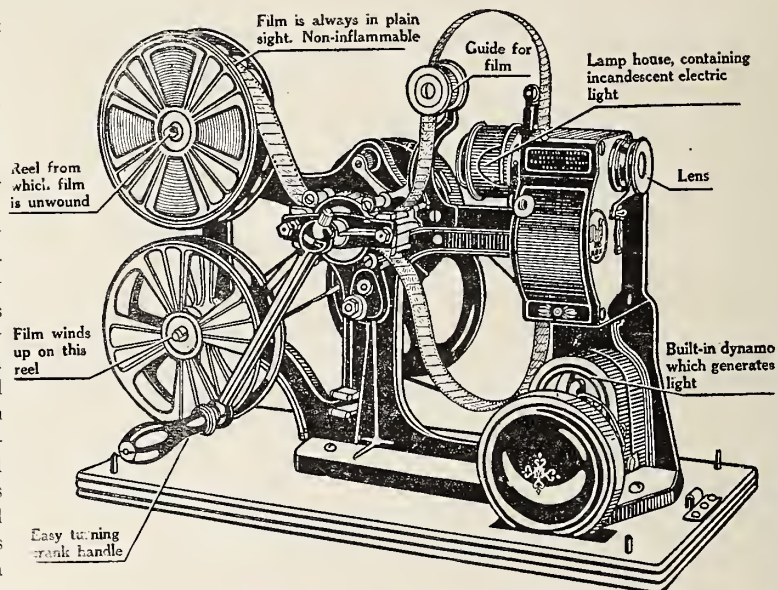

culated to meet with emphatic success, and the satisfactory results secured by the company to date are evidenced in the fact that the Pathescope is now being handled by prominent houses, including talking machine dealers, from coast to coast.

Pearsall Victor Service

New York

WHAT the Victor dealer wants to-day is more of a "friendly service"—a service which not only involves the quick and complete furnishing of Victor machines and records, but includes co-operative consulting with regard to business management in general. This is the character of Pearsall service, and this is why a large number of new dealers have been enrolled as Pearsall boosters.

Test our service for the holidays! It will prove profitable to you.

Silas E. Pearsall Co.

Victor Distributors

18 W. 46th St. (near Fifth Ave.), NEW YORK

CARRYING AN IMMENSE STOCK.

C. Bruno & Son, Inc., Are Well Prepared for Big Victor Demand During the Holidays.

The accompanying illustration taken recently at the uptown storeroom of C. Bruno & Son, Inc.,



Part of the Great Stock of Victor Machines Carried by C. Bruno & Son, Inc.

353 Fourth avenue, New York, gives an adequate idea as to the extent of the Victor machines constantly carried in stock by this Victor distributor. This branch of the Bruno business is under the personal direction of Chas. F. Bruno, secretary and treasurer, who believes thoroughly in the "wholesale only" policy of the concern, this being

reinforced by a service that is complete and prompt. "Particularly at this season of the year," said Mr. Bruno, "the average dealer needs goods promptly, and also requires that his order be completed in full. This, of course, puts it up to the jobber for close co-operation, and as we specialize in working with the dealer, he re-

deep affection. It will, therefore, be a source of pleasure and gratification to them to know that his new and broader field offers an opportunity for even greater usefulness, and even greater achievements.

"John A. B. Cromelin, who has been appointed general manager, entered the service at the bottom of the ladder when he was a boy, eighteen years ago, served as private secretary of the president and later as assistant executive officer in Bridgeport. Thirteen years ago he was transferred to Europe, where he was employed in Paris and Berlin. He was St. Petersburg manager and for the last four years has been European general manager. His successful record in the latter capacity, where his duties have been in many respects like those of his new position, is a natural prelude to his advancement.

"Louis Sterling, the new European general manager, has been the sales manager in Europe for a number of years and justly bears the reputation of being one of the most popular men in the trade."

IMPORTANT NEW PATHE AGENTS.

The Pathé Frères Phonograph Co., 29 West Thirty-eighth street, New York, announced the closing of several important deals this week whereby the machines and records manufactured by this company will receive adequate representation at the hands of prominent concerns.

The most important of these new agencies is Marshall Field & Co., Chicago, Ill., internationally prominent as one of the leading merchandising institutions in the world, who are in a most advantageous position to introduce the many merits of the Pathé Frères line.

Other new agencies include the N. Snellenburg Co., Philadelphia, Pa., one of the best-known department stores in the East, which now maintains a large and successful talking machine department, the Atlantic Talking Machine Co., Boston, Mass., a recently formed concern which will handle the complete line as jobbers in an aggressive manner, and Ludwig Baumann & Co., New York, one of the prominent local furniture houses.

GEORGE W. LYLE RESIGNS

As General Manager of Columbia Co. to Give More Time to Broader Interests of Company—J. A. B. Cromelin Succeeds Him—President Easton's Fine Tribute Deserved—Promotion for Louis Sterling in London.

George W. Lyle, first vice-president of the Columbia Graphophone Co., who, in addition to his duties as director and member of the executive committee, has held for many years the position of general manager, resigned the last name position on November 12, in order to be relieved from the details incident to the great growth of the business and be freer for consultation with the president and directors, and to give more deliberate attention to the larger matters of the company, in which his long and intimate experience has made him so valuable.

John A. B. Cromelin, European general manager, has been transferred and appointed to the vacancy and Louis Sterling, at present European sales-manager, has been appointed European general manager.

President Easton in commenting on the changes said to the Talking Machine World:

"Mr. Lyle was appointed general manager in 1904 and has, therefore, held the position for nearly eleven years; so long a time that more than ordinary notice should be taken of his change of duty. He has performed his work with rare ability and conscientiousness, regardless of his own comfort, convenience and health, with an eye single to the interest of the company, and with the energy characteristic of a human dynamo. During my disability and absence after the panic of 1907 he was for several months sole executive of the company, and by his able administration of the many intricate problems presented during that perilous time, earned the admiration and gratitude of all of the officers, employes and stockholders of the company. He so directed the affairs of the company as to change the showing on the balance sheet from the low point of 1908 to the very substantial profits of recent years and the present time, building up sales by leaps and bounds. Everyone concerned, from the highest to the lowest in the

receives a service that is of exceptional strength. Nothing is more exasperating than to order goods and not get them, especially when the dealer has a customer for the goods that he orders. This is why we work hand in hand with the merchants, and explains why this branch of our business is constantly growing."

service of the company owes him a substantial debt of gratitude, and those who know him personally, as so many do, combine with gratitude a sense of

Your Victrola Stock Can Be Complete All the Time

If You Avail Yourself
of the Grinnell Service

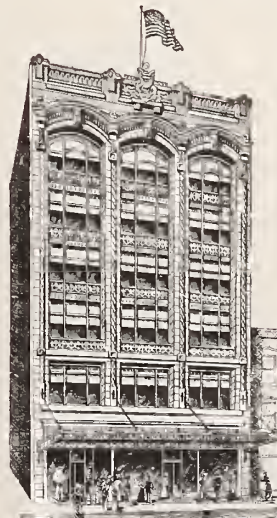

GRINNELL BLDG., DETROIT

Our location enables us to serve with especial promptness all Victor dealers of Michigan, Ohio, Indiana and adjoining States.

We have constantly on hand an immense stock—ready at all times for emergency calls. Your orders will receive immediate attention, and the transportation facilities at our command insure the very quickest delivery.

Check Up Your Stock Now

Be ready for the greatest Victor, Victrola and Record business you've ever done. Send in an order to-day for the stock you're low on. Give the Grinnell service a test. *You'll find it equal to your every demand.*

Grinnell Bros.

Grinnell Building, 243-245-247 Woodward Ave., Detroit



**It's safe to say because it's easy to prove
—that the dance product of the Columbia
Record Laboratory maintains an unparal-
leled high average.**



(Write for "Music Money," a book "full of meat" for those dealers interested in quick and frequent turnover of capital.)

Columbia Graphophone Company
Woolworth Building, New York

NEW STORES IN THE TWIN CITIES.

Three New Columbia Dealers Enter the Field After Visit of Vice-President Lyle—New Edison Stores Also Opened—Edison Shop Is Most Attractive—Heavy Victor Business.

(Special to The Talking Machine World.)

MINNEAPOLIS and ST. PAUL, MINN., November 9.—Three Columbia stores have been opened in the Twin Cities since the October issue of The Talking Machine World went out on its mission—two in Minneapolis and one in St. Paul. Following the visit here a month ago of President Lyle, of the Columbia Co., came Clifford Ely, traveling agent of the wholesale department, and he remained ten or twelve days, and at the end of his stay saw three new branches in successful operation, in a measure due to his efforts, or at least dependent upon his judgment. The Northwestern Music Co., and the New England Furniture Co., which for a long time has had a Victrola department, installed large stocks of Columbia Gramophones, records and supplies. In St. Paul the Lehnert's Piano Co. on upper Wabasha street, adds a Columbia section to its activities.

The new Edison Shop in St. Paul, under the control of the Minnesota Phonograph Co., is an architectural dream. It commands attention by the beauty of the interior arrangements, and with three street fronts has the most advantageous possibilities for display. Manager William Lucker reports that the store is a real magnet and it started to draw trade immediately it opened. A Hawaiian tenor holding forth at regular intervals has given the Kanaka records a great vogue.

The new Edison store at 612 Nicollet avenue, Minneapolis, opened Saturday, November 7, for business, but the formal opening is set for a later date. This also is the last word in phonograph display and demonstration establishments, and with its sister in St. Paul, is calculated to bring the Edison instruments to general public notice. Manager Laurence Lucker states that his company has distributed more than five carloads of Edison

goods since August 1. In every way the outlook is excellent for the old favorite.

The popularity of the Victor instruments continues unabated, according to W. J. Dyer, of W. J. Dyer & Bro., jobbers of these goods. The country demands are hard to satisfy, while the half-score retail stores in St. Paul and Minneapolis are doing excellent business. Their recital programs, always well arranged, are attracting crowds to this establishment.

Archie Mathies, of the Talking Machine Co., finds that trade is better than ever. The regular Thursday evening recitals have been varied by the appearance of C. A. Pomeroy, a clever son of Terpsichore, who has all the latest dancing steps down to finest edge and is willing to show them off to the public. The store is more than filled on the nights that Mr. Pomeroy appears.

The weather in Minnesota this fall has been too fine, declares C. P. Herdman, manager of the St. Paul Columbia store. It is so nice that the people are out motoring or promenading when they should be at home around a grate fire listening to Columbia music. It surely is true that not only talking machine business, but all other business, would be better if the weather was not so seductively pleasant.

OFFERING THE PATHÉGRAPH AS PRIZE

The Pathégraph, manufactured by the Pathé Frères Phonograph Co., 29 West Thirty-eighth street, New York, was offered last Sunday by the New York Tribune, one of the leading local newspapers as a special prize for the public schools of New York in a voting contest now being featured by that paper. An illustration of the Pathégraph was prominently displayed, and the contest editors called attention to the fact that the instrument is a unique one, in that it is a combined phonograph and music and language instructor. In addition to playing Pathé discs in the usual manner, the Pathégraph embodies a special attachment for teaching music and languages, which makes it particularly adaptable for school use.

NO MORE DELIVERY DELAYS.

J. B. Ogden Makes New Arrangements for Manufacturing the Ogden Sectional Record Filing Cabinets and Will Be Able to Make All Shipments Promptly and Without Delay.

(Special to The Talking Machine World.)

LYNCHBURG, VA., November 10.—J. B. Ogden, manufacturer of the Ogden Sectional Filing and Sales System for talking machine dealers, which has measured up fully to expectations wherever installed, announces that he has made arrangements with a large and responsible Western factory to make up a large number of cabinets for him under a guarantee that the cabinets will be delivered on the dates specified in the contract and that he will, therefore, be in a position to meet every demand of the trade promptly, without annoying delays.

Through the delay of the Southern factory which formerly made the cabinets, Mr. Ogden was forced to disappoint numerous customers who sought quick deliveries, but the new arrangements will put an end to those annoyances. Mr. Ogden now has a substantial supply of cabinets ready for shipment, so that dealers may secure them and enjoy their advantages during the holiday trade.

TO DEAL IN PHONOGRAPHS.

The Ideal Phonograph Co., Plainfield, N. J., has been incorporated with capital stock of \$10,000 to deal in phonographs. The incorporators are Albert R. Palmer, Harry Lawson and William Hollinger.

The L. S. Donaldson Co., Minneapolis, Minn., has just opened a new Victrola department in its store, of which L. M. Knickerbocker, formerly manager of the Stewart Dry Goods Co. in Louisville, Ky., is in charge.

One of the most recent accounts closed by the Columbia Graphophone Co. is that of Goldburg Furnishing & Carpet Co., 143d street and Third avenue, New York, which will handle the complete Columbia line.

TO VICTOR AND COLUMBIA DEALERS

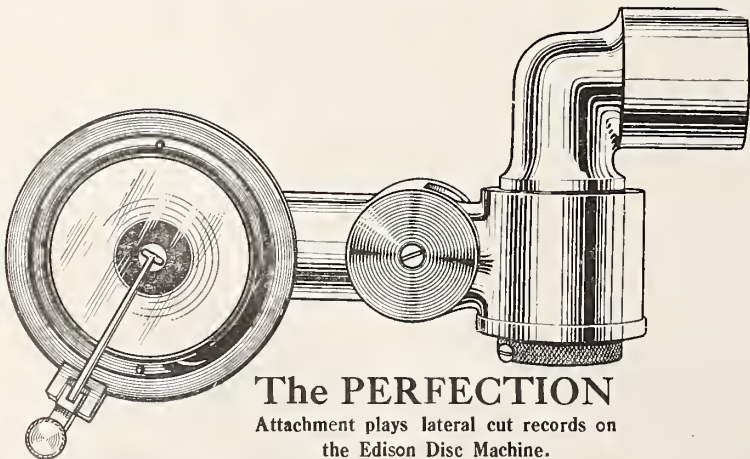

The PERFECTION
Attachment plays lateral cut records on the Edison Disc Machine.

Do you want to sell records to owners of Edison Diamond Disc Machines? If you do, carry our "PERFECTION" attachment in stock.

Edison Disc machine owners will be coming to you every day, asking you if the records you sell can be played on their machines. If you carry our attachment in stock, you not only have a chance to sell it, but also to make record sales and add a new name to your mailing list. We can also furnish you with a reproducer which is fitted to our attachment. Price of sample attachment \$2.50, gold-nickel or bronze finish. With reproducer, any finish, \$4.75.

Cash or check must accompany each order for sample. We will quote you quantity price on request.

NEW ENGLAND TALKING MACHINE CO.
132 Boylston Street
BOSTON, MASS.

THE QUESTION OF SENDING RECORDS ON APPROVAL.

Discussed in an Illuminating Manner by Benj. Switky, the Well-Known Victor Distributer of New York, Whose Retail Experience in the Past Serves to Give Weight to His Opinions—Difficult to Make Hard and Rigid Rules—Common Sense Must Govern.

A much mooted question in the talking machine trade is that of the advisability of sending records out on approval, and the opinions pro and con have been numerous and varied. Some interesting views on that important subject were recently contributed to *The Voice of the Victor* by Benj. Switky, the well-known distributor of New York, who wrote:

The value of the practise of sending records out on approval has often caused dealers to question their own wisdom and judgment. Intended primarily to stimulate and increase the total volume of business and the consequent profits, it has been found by many dealers to have the opposite effect. While sounding good in theory, it seems to work out badly in practice. Selecting records on approval seems to be handled by the public in such a way as to make it a sister scheme to the music roll exchange or the circulating library. Instead of buying music rolls outright, the public prefer to pay a modest sum for the *use* of the rolls, thereby enabling them to enjoy a greater variety at lesser cost. Therefore a little discussion on the subject will do more good than harm.

To quote the sentiment recently expressed by Ernest John, editor of *The Voice of the Victor*, every dealer should have his convictions and should sell and work and fight accordingly. Hence I shall begin by saying positively that the practice of sending sets of records out on approval is in most cases unprofitable, harmful and greatly to be deplored.

There are just a few conditions under which a dealer is justified in sending records on approval:

1. If the customer is an invalid and cannot come to the store.
2. If the customer lives at a great distance and rarely, if ever, comes to your town.
3. If your store is uninviting, either because of location or lack of interior comfort, and your customer—particularly a lady—feels it incompatible with dignity to condescend to trade at the store.
4. If your customer is a busy business man, who doesn't mind spending money liberally, but who simply cannot devote the time necessary to spend the money.
5. If your customer is a millionaire—either near- or multi-
6. When delivering a machine bought by one person and intended for another you might offer to send some choice records for try-out; but be careful to impress on your customer that you do not make a regular practice of doing this.

There may be one or two other instances in which the extenuating circumstances are sufficient to warrant "on approval" delivery.

But look the practice square in the face. Ask yourself one or two pertinent questions. Recall a few instances in which good customers have been

spoiled. After that you may vote pro or con.

If you will turn over a few leaves of your ledger (presuming that you have a number of charge accounts) and compare the purchases of Mr. Jones or Mr. Brown during last month and several months previous, you will find that of late they have not bought liberally. Oh, yes! There have been quite a few charges, but somehow the merchandise credits are nearly equal to the charges. You will recall that Mr. Jones was a dandy buyer when he first started dealing with you. The love of new records gripped him like an intermittent fever. He needed a few records for Sunday, and a few more newer ones when expecting company. If the next holiday happened to be Christmas, or Easter, or the Fourth of July, you could count on selling him \$10 or \$15 worth of selections appropriate to the occasion. Somehow or other it is a fact that now you get from Mr. Jones only \$5 or \$6 worth of business a month—even less in some months.

Now, if Mr. Jones were to cease coming to the store we would presume that he had either lost interest in the Victrola or that he found the pace of buying new records too strong to keep up with, or perhaps he had gravitated to another dealer's shop. Nothing of the kind! He still drops in to see you as usual. His enthusiasm has not waned an iota. He is enjoying more new records than ever before. There is just this little difference: Instead of paying for his concerts, *you* furnish the music free of charge. You charge a batch of records to his account, deliver them, then you send for the returns and issue a credit memorandum. He is careful to keep a record or two, just for decency sake, so as to repay you for your trouble, and just so that you don't get wise to his scheme.

If you will watch closely you will find that he usually wants a new set of records sent to his house on Saturday, so that he can play them over on Sunday, or on the eve of a holiday, or just in time to be played over at a gathering of friends.

Of course, the dealer is wise; or his bookkeeper or clerks soon tip him off that there's nothing to it—that Mr. Jones is using him for a good thing. One little error in crediting the returns wipes out the profit. In fact, the value of the salesman's time in making up the selection, the delivering, the bookkeeping, etc., have in advance dissipated the profit on Mr. Jones' business. The return of one record scratched may nullify the whole transaction.

Here is where the dealer finds himself in a dilemma. While realizing that he can never more expect to see Mr. Jones' money in denominations of fives, tens or twenties, he finds it embarrassing to have to point out to Mr. Jones that he no longer buys enough to make it worth while catering to him. The situation becomes delicately complicated. To continue the approval deliveries is irri-

tating. On the other hand, to suggest to the customer that the privilege must be withdrawn is tantamount to inviting him to transfer his patronage elsewhere. For that is just what happens usually.

The "approval" game (I here speak from knowledge local to New York City and vicinity) is being played overtime. After being turned down by one dealer they drift to another, and then to still another, in each case asking for records charged on approval without even thinking it necessary to first establish their credit responsibility.

As a test of the value of such prospective customers let the dealer submit to them two propositions: First, unless the credit is beyond question, cash should be paid for the records. Second, the customer must agree to keep positively a certain proportion of the records submitted—say one-half, or not less than one-third.

Usually there are too many critics at home passing on each record. If you are not there to influence the choice of a selection you lose the opportunity of making a sale. Although I believe firmly in having harmony in the home, a salesman will find it easier and more profitable to suit with different records the individual taste of each member of the household. If you leave it to them the vote will never be unanimous, and so long as they save money by rejecting, the noes will always win.

If you feel that you *must* go after the record business by serving the customer at his home, then let your salesman preside at the demonstration.

Leaving with a number of customers sets of the new monthly records is detrimental to the best interests of your record stock. First of all, you are obliged to order too many of certain selections that prove to be poor sellers—records that eventually drift back to the store and help to pile up an unnecessarily heavy stock of surplus.

Sending out a package of certain selections on approval for a few days means to some dealers that these numbers will be out of stock until the dealer finds out which are sold and should be replaced; or they are re-ordered at once and the stock doubled when the others come back.

The dealer who indiscriminately sends records out on approval eventually gets the reputation of selling worn records. He is not present at the customer's home to see whether his records have been played over once, twice or three times before being rejected. We all know that records do not improve with use.

We have known unscrupulous buyers to order a record of a selection which they already had on hand and then return the worn-out record, keeping the new one.

However, all the foregoing objections would be swept away automatically if the approval practice were profitable. But such is not the case. The harvest reaped may be reviewed as follows: 1. Diminished business. 2. Good buyers perverted or lost. 3. Cupidity encouraged. 4. Energy wasted. 5. Abused records returned to stock. 6. Capital wasted in excess stock.

Six lots of records submitted on approval will not sell as much goods as a good salesman can sell the same customer in one sitting at the store.

Get an *Extra Profit* on Your Talking Machine Sales

CHRISTMAS will soon be here and with it the best talking machine season of the year. Prepare to make an *extra profit* on the instruments you sell by *also selling Udell disc record cabinets, which exactly match standard instruments in style and finish.*

Every customer who buys a talking machine is sure to want a cabinet for holding it and filing the records. Show him Udell cabinets—and make *another sale.*

Udell cabinets come in eight popular styles. Six of these have either perpendicular or horizontal shelves for filing. Two have only perpendicular shelves.

New Booklet No. 45 completely describes the Udell line. Christmas is only a few weeks off, so write for this new booklet *today.*

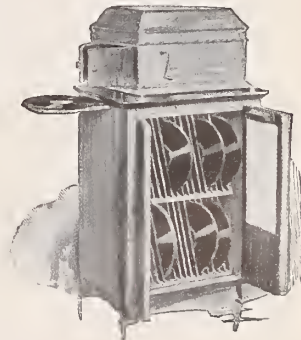

The Udell Works, 1205 W. 28th Street, Indianapolis

"EDISON DAY" IN ST. LOUIS.

Celebrated by Opening of New Concert Hall of the Silverstone Music Co.—Prominent Edison Disc Dealers Present.

(Special to The Talking Machine World.)

St. Louis, Mo., November 7.—Edison Day, October 21, the anniversary of the invention of the incandescent electric light, was celebrated at the Edison Shop, as the Silverstone Music Co. warehouses are beginning to be called and as they probably will be known when the piano business finally is disposed of, by the formal opening of the new concert hall, a special concert program, which was attended during the afternoon by several hundred ladies and by a gathering of dealers at night, for a technical and business discussion of the Edison disc machines and which closed with a banquet and a program of toasts.

The night gathering, from a professional standpoint, was much more significant. More than thirty men interested in the sale of the Edison disc machines were present and listened without tiring to a technical talk on the make-up of the machine from Mr. Silverstone, and then plied him with questions as to how to meet the little everyday difficulties that confront them, also the best answer to certain frequently made arguments and oft repeated questions. This talk was demonstrated with equipment and parts of machines from the workshop and with reproductions of special demonstrations of different kinds of music.

Those present, all dealers or dealers' representatives, were: Melon Harry, Charles Dusenberg, H. Dusenberg and J. D. Barthel, of the Concordia Music House; F. Coleman, George Lamothe, H. A. Tunehorst and L. R. Tunehorst, W. P. Davis and Leon Davis, of the Davis Music Co.; W. H. Thweatt, of the Thiebes Music Co.; R. E. De Money, E. B. Cheatham, Prof. Charles Kunkel, Charles Kunkel, Jr., and Charles Jacob Kunkel, of Kunkel Bros.' Piano & Music Co., and representing the Silverstone Co. were Mark Sil-

"MAGNET" DECALCOMANIE NAMEPLATES

From the
DORAN CO.
45 MICHIGAN AVE.
DETROIT

SOLD BY
HURTEAU WILLIAMS & CO.
MONTREAL — OTTAWA

Kunkel Piano Co.
BALTIMORE

FOR TALKING MACHINE
CABINETS ETC.

EASILY AND PERMANENTLY APPLIED.
BE THE FIRST DEALER IN YOUR CITY
TO USE THIS POPULAR METHOD OF AD-
VERTISING.

500 MINIMUM QUANTITY MANUFACTURED.
SEND FOR SAMPLES AND PRICES.

GEO. A. SMITH & CO. INC.
74 CORTLANDT ST. NEW YORK

— FROM —
THE PHONOGRAPH CO.
1240 HURON ROAD (Intersecting 130th St.)
CLEVELAND

SOLD BY
WALTER D. MOSES & CO.
Oldest Music House in VA. and N.C.
103 E. BROAD STREET
RICHMOND, VA.

SOLD BY
J. E. STRATFORD
AUGUSTA, GA.

verstone, president; E. E. Raddon, secretary; L. M. Schlude, floor manager; C. H. Routledge and William Miller.

complete, so that the increased facilities will be available for any sudden demand.

HOLIDAY PROSPECTS EXCELLENT.

American Talking Machine Co. Keeping Ahead of Last Year's Business Record—Rearrangement of Store Completed.

R. H. Morris of the American Talking Machine Co., 368 Livingston street, Brooklyn, N. Y., expresses himself as being well pleased with the manner in which business is holding up this fall. He states that up to date every month during the year has shown an increase over the corresponding month of 1913 and the prospects are that the holiday trade will uphold the record for the balance of the year. The orders received from various dealers indicate that they have faith in the holiday prospects and are willing to place orders on that basis.

The American Talking Machine Co. are doing an excellent business, particularly in Brooklyn and Western Long Island, and pays particular attention to quick service on rush orders, getting the goods to the dealer without delay, thereby saving sales for him. The rearrangement of the company's store, including the moving of the demonstration booths nearer the front and the installation of additional shelving for records, is now

LANSING ADDS NEW LINE.

Khaki Moving Cover Now to Be Had in Grades to Suit All Demands in Matter of Price—Mr. Lansing Books Big Orders for the Expensive Styles of Covers.

E. H. Lansing, 611 Washington street, Boston, Mass., manufacturer of Lansing's khaki moving cover for talking machines, announces that he has added a new quality line to his covers at a lower price. This new cover is interlined with cotton batting instead of felt and in the large size sells to dealers for \$5 each. The small size, which is made for handling the small models of the various machines, wholesales for \$3.25.

Mr. Lansing also announces a new strap, made of wide webbing, with handles and patented buckle, which is sold for \$1. Thus if a dealer wanted a cotton lined cover he would specify "B" grade, the designation given to this new line to classify it from the covers with felt lining.

Mr. Lansing has just completed a two weeks' tour which carried him to the talking machine centers about New York, Philadelphia, Baltimore and Washington, and he reports a very strong demand for Lansing covers, particularly in the more expensive styles.

LAST CALL BEFORE XMAS

We offer your customer most for his money. We offer you the best inducement to make sales. The machine pictured does everything any phonograph will do. Can you afford to ignore it?

OUR BEST OFFER APPLIES TO SAMPLE ORDERS

\$15

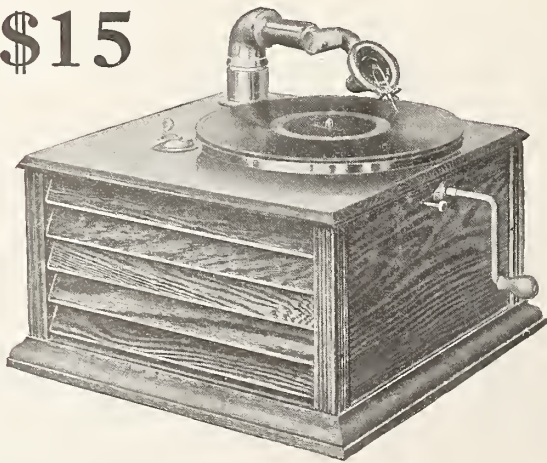

This Instrument has a
Concealed Horn



A MERE TURN of the Sound Box makes it possible to change from the Steel Needle to the Diamond Point.

CRESCENT RECORDS

For use with Jewel Point

12-inch Double Side.....	\$1.00
10 " " " "75
Jewel Points.....	1.00

These Records being of the
HIGHEST STANDARD
makes our proposition to the
Trade complete.

We Depend Upon No Other Record

Do You Want to Increase Your Diamond Point Record Sales?

Our Three Styles—\$12.50—\$15—\$40—will do it.

Crescent Talking Machine Co., Inc.
99 CHAMBERS STREET NEW YORK CITY

ST. LOUIS ASSOCIATION ACTIVE.

Five Members Join Associate Retail Merchants and Plan Energetic Campaign of Business Betterment in the Saintly City.

(Special to The Talking Machine World.)

St. Louis, Mo., November 9.—The Talking Machine Dealers' Association, of this city, has apparently bridged its first difficulty, and has itself established on a firmer foundation. At a called meeting, November 4, it was announced that five of the members of the association have joined the Associated Retail Merchants, and had been named as the Talking Machine Dealers' Committee, which will give to them the benefits of the Associated Retailers' facilities and business rooms, and they are welcome to call other dealers into conference whenever occasion arises, which will be whenever the officers of the association conclude there are matters requiring special attention. The dues of the Retailers' Association had proven a bar to the affiliation of all of the talking machine dealers with that association. The five joining the Retailers are the Columbia Co., the Thiebes Piano Co., the Silverstone Music Co., the Val Reis Piano Co. and Koerber-Brenner Music Co.

The first stumbling block of the association was an advertisement by one of the retail dealers advertising terms that did not seem to agree with the association agreement. It was discovered that this firm had multiplied the monthly terms agreed upon by twelve, to get a yearly payment, and then divided that by 52, and had advertised weekly payments on that basis. It was announced that this difficulty would be adjusted, and perhaps some steps taken to relieve some other advertising that has been objected to and which appeared to be due to a lack of understanding, rather than to deliberate intent to disobey the agreement of the association, which has done much for the trade.

RECITALS ATTRACT PURCHASERS.

C. I. Abelowitz Doing Good Work in Expansion of Business of the Talking Machine Department in Herz Department Store, Terre Haute.

(Special to The Talking Machine World.)

TERRE HAUTE, IND., November 2.—Chester I. Abelowitz, manager of the talking machine department of A. Herz's department store, of this city, announces his intention to repeat the recital which he so successfully gave last month and will, in fact, give a series of these performances extending through the winter.

Mr. Abelowitz gave the first performance October 13 in the restaurant room of the big department store, and although the seating capacity of the hall is but 350, it was crowded to almost 500, and many were turned away an account of the limited space. The program engaged the services of Seigfried Philip, baritone; Mrs. David Silverstein, soprano, and a Caruso number and the Lucia Sextette on the Victrola. There was also a demonstration of modern dances by Chester Laverty and Mrs. Schomer.

Similar recitals have been given from time to time in various sections of the country, but none has been better managed than this one. An announcement was made in the local dailies two or

three days previous and additional comment was made in the news columns of the papers because of the novelty of the occasion. Tickets of admission were given out, on the reverse side of which was a space for the name, address and city of the one presenting it. These tickets were all taken up at the door, and through the information thus secured numerous prospects were obtained.

NEW STYLES OF UDELL CABINETS.

Some Specially Emphasized Designs That Will Appeal to the General Public—How the Udell Works Help in the Way of Service.

The Udell Works, Indianapolis, Ind., have issued a folder specializing in some of their snappy styles of disc record cabinets. This folder illustrates Cabinet Styles 425, 428, 429, 402, 1417, 418, 427, 422, 417 and 412.

These designs are selected from among those of the best sellers and are absolutely guaranteed as to construction and finish. Among the special styles shown is Style 429, which is designed particularly for the new Edison disc machines, Styles

B-60 and A-80. Cabinets are fitted with both horizontal and vertical shelving, the upright wooden partitions being used unless otherwise specified.

The special service that is being rendered by The Udell Co. is the offer of three retail advertisements for featuring Udell products to the consumer. These are furnished in electros and are all ready to be published in newspapers.

NEW AUTOMATIC STOP.

A new automatic stop has been perfected by the Sonora Phonograph Corp., 57 Reade street, New York, which will be ready for the trade in about one month. It is a simple device and requires no adjustment to the size of the record, nor does it require "placing in position" when the record starts playing. It is rather unique in its action, for whether the entire record is played or only half or a quarter of it, the action of stopping is the same.

C. P. Chew, formerly with the Edison Co., is now covering New York State in the interests of the Sonora phonograph.

Get in Line Now

If you have not signed a dealer's license agreement with us it is policy to do so at this time.

The **RUSH SEASON IS COMING** on and you are liable to need goods that your distributor is short on.

Sign up—and send us your short orders so that you will be prepared to do business with us on larger orders before the last minute arrives.

Our policy is to give: "**Our All-Year-Round Dealers**" the first chance when goods are short. Be one of "**Our All-Year-Round Dealers.**"

WE ARE LIVE DISTRIBUTORS

AMERICAN TALKING MACHINE CO.
368 LIVINGSTON ST., BROOKLYN, NEW YORK CITY

READY REFERENCE OF GENERAL SUPPLIES

DEALERS

Send for our "Trial Proposition" on the Regina Hexaphone—the latest and best paying popular priced coin-operated instrument for use in public places.

THE REGINA Co.

211 Marbridge Bldg., 34th St. and Broadway, New York City
Manufacturers of Regina Music Boxes; Reginaphones; Coin-operated Mandolin Orchestrions; Vacuum Cleaners and other specialties.

Mermod & Co.

505 Fifth Avenue New York

Manufacturers of

Talking Machine Supplies

Motors—Sapphire Points

Diamond Points a Specialty

Keep Your Record Stock with

THE Gelse SYSTEM

Costs about \$2.00 for 250 records for 50 years
Send for 20-page catalog

THE SYRACUSE WIRE WORKS,
SYRACUSE NEW YORK

THE TRADE IN PHILADELPHIA AND LOCALITY

(Special to The Talking Machine World.)

PHILADELPHIA, PA., November 9.—There has been a continuation of the excellent business that Philadelphia has experienced during the year, according to the reports of all the talking machine dealers for last month. October has been one of the most satisfactory months of the year, and the increase over last year during the month has been as large as any other. If November and December continue to show such remarkable gains, this will not only be a banner year but a bonanza year.

In spite of dullness in many other lines there seems to be no lagging in the talking machine business, and this is not shown in any one line, but in the general business from beginning to end.

There has been little change in the talking machine business in Philadelphia during the month. There has been a new Edison dealer established in

the piano firm of Story & Clark, who have opened up a very large department and have placed in charge Thomas C. Henderson, recently manager of the Philadelphia Estey house, and previous to that connected with the Columbia Graphophone interests in Philadelphia. Mr. Henderson is a man of wide experience in this line of business, and he has already inaugurated an active campaign.

Ramsdell & Son now have their Edison department in full running order. They have located it in the basement of their piano store, which is nearly level with the street and with windows in which they can make, and are making, a satisfactory display.

Louis Buehn reports that business in October was very good, and that it shows a substantial increase over last year. He says that the outlook for November is that business is going to continue right through to the holidays, and that his firm will certainly close the largest year's business that his house has ever enjoyed. The machine sales have been especially good, but there is a slight scarcity of machines of a certain type. He says: "The record situation has not improved to any great extent, and the ideas of the purchasers have been running very largely to the dance music and other popular selections. The selling of Victor opera records are a little slow at present, for the reason, presumably, that the opera season, which creates the demand, is still a few weeks off."

Blake & Burkhart, the Edison dealers at Eleventh and Walnut streets, report that their business in October was first rate, and that this month started off in good shape. A. C. Ireton was over to Philadelphia last week and brought some encouraging news to the Philadelphia Edison dealers to the effect that the company were about to send to Philadelphia a force of six men to start an Edison advertising and publicity campaign.

Frank Gittelson, the young Philadelphia violinist, who has just returned from Europe and made his debut here with the Philadelphia Orchestra, recently, has been a frequent visitor to the Blake & Burkhart warerooms to hear the Edison "Ave Maria" record made by his teacher, Carl Flesch. This is one of the most wonderful violin records ever placed before the public in this manner, and practically all of the Philadelphia violinists have

been to hear it and many have purchased the record.

Blake & Burkhart began on Monday of this week their weekly Monday evening concerts, which have drawn in the past a most select audience. Emil Bauer, formerly connected with the manufacture of musical instruments and with the Keen-O-Phone, has entered the employ of this firm as a salesman.

The Pennsylvania Talking Machine Co. has met with a wonderful success in Philadelphia in October. Manager Eckhart, who started in Baltimore years ago, and ever since has been deeply interested in that city, has again connected himself in a way with the talking machine business in that city, and is spending one or two days a week there. Many of his early friends in the business will no doubt be interested to know that the Columbia Graphophone business in that city, at 305-7 North Howard street, will have his personal direction and supervision.

In Philadelphia, Mr. Eckhart says, last month every branch of his business showed a substantial gain over the same month of last year, and that with the business now in hand they will close out the year with a handsome gain over last year. The new products, the Leader, Mignonette and the De Luxe at \$200, are meeting with an enthusiastic reception. They have sold them as fast as they could be received. Where they would like to have a big supply in the warehouse, they have only a few days' supply and are dependent upon receiving frequent shipments from the factory, but the factory has promised to keep them amply supplied.

John A. B. Cromelin, European manager of the Columbia Co., paid Mr. Eckhart a "society" visit the past week. The Pennsylvania Company has had an excellent dictaphone business in October, supplying, among other firms, the Victor J. Evans Co., the Elliott Lewis Electric Co., Gellander & Co., Tacony; Dr. Cadwallader, the Maryland Casualty Co., and H. O. Wilbur & Co., the chocolate manufacturers. Julian D. Westervelt, formerly supervisor of sales agents with the dictaphone, has been placed in charge of the Pennsylvania company's dictating machine business.

Gimbel Brothers report that they have made a big gain in October over last year, and November has started in very good, due in a great measure to an enticing offer they are making for Victor

**PENN
PHONOGRAPH CO.
PHILADELPHIA**

**Largest
Stock of
Victor Records
and Victrolas
in
Pennsylvania**

**Orders Filled
Immediately
Upon Receipt**

**Give us a trial and be
convinced**

**PENN PHONOGRAPH CO.
17 South 9th Street
Opposite Post Office, Philadelphia**

VICTOR

A complete line of Victor products, from the smallest repair part to the biggest model of machine. Every shipment made promptly.

EDISON

Cylinder goods, machines and records; full stocks and immediate deliveries. A good popular-priced line for most any territory.

**Louis Buehn
Philadelphia**



The Columbia increase is due to the soundest kind of good business. The instruments are right, the records are right, the sales policy is fair and square and the advertising is effective.



(Write for "Music Money," a book "full of meat" for those dealers interested in quick and frequent turnover of capital.)

**Columbia Graphophone Company
Woolworth Building, New York**

machines, records, albums, etc., at an attractive price for the combination. They are arranging a novel Christmas present for their customers, and will give them a new and one of the best record cleaners yet gotten out with every purchase. Each cleaner will have the firm's name on it.

H. A. Weymann & Sons report that October was the biggest October they have ever had, and that it was ahead of the other months of the year in percentage, and that thus far every month has run substantially ahead of last year, and they are anticipating a business this year of at least a third more than they have previously enjoyed. Mr. Weymann attributes his success to the foresight in which they secured a big stock of instruments and records, and by urging his dealers to lay in their supply early, they are able to get all goods promptly, and by doing so already they have been receiving duplicate holiday orders.

INTRODUCE NEW FLEXIBLE NEEDLE.

John M. Dean, the Prominent Manufacturer, Announces the "Flexible Four-pointed Steel Needle" for Talking Machines.

John M. Dean, Inc., Putnam, Conn., manufacturer of talking machine needles, announces the perfection of a new needle which has been patented in this country, with foreign patents pending. It is called the "Flexible four-pointed" steel needle, for the reason that it plays four tunes with one needle. These are put up in attractive packages of 200 needles.

Commenting upon the "Flexible" needle, John M. Dean, Jr., of this corporation, said: "In the first place, Flexible needles bring out the music from any record and make old records sound like new. They eliminate scratching and save the records from wear. They play the longest records perfectly and, being made of the best steel obtainable, will give a service that is of unusual quality."

Full particulars and samples may be secured upon application to John M. Dean, Inc., Putnam, Conn., or to Samuel Levin, Highland Park, Ill.

SOME NOTABLE RECORDS

Made by Richard Czerwonky, Albert Farrington and H. E. Humphrey for Edison Co.

The Edison Blue Amberol record list for December contains records by three important personalities, which are bound to win a large measure of popularity with the general public. Richard Czerwonky, a violinist of international fame, who



Richard Czerwonky. Albert Farrington.

has played with the great orchestras of Europe and who was concert master with the Boston Symphony under Dr. Muck and now is concert master with the Minneapolis Symphony Orchestra, is represented by "Adoration," Felix Borowski's lovely composition, accompanied on the piano by Robert Gayler. This record is notable for the purity of its tone, the brilliancy of execution, the perfection of effects; in brief, a most artistic effort worthy of the reputation of this famous violinist and a credit to the Edison laboratory.

Albert Farrington, the well-known baritone, who is widely known in concert circles and at present soloist at St. Ignatius Church, New York, has made an excellent record of "It's a Long, Long Way to Tipperary," the Irish song which has so caught the fancy of the English soldiers that it is now being sung by the French and Russians as

well. It is accompanied by male chorus and orchestra, making a record full of vigor. Mr. Farrington has also made a record of "Rule Britannia," accompanied by a chorus band. He gives this famous anthem a most inspiring presentation.

While not a newcomer in the Edison Blue Amberol list, Harry E. Humphrey furnishes a timely contribution in "The Night Before Christmas," a recitation which has so idealized the true spirit of Christmas and Santa Claus that it has become a classic not only in this country, but throughout the world. Mr. Humphrey imparts true reality to his clever reading, and his perfect diction enables one to follow him with ease.



H. E. Humphrey.

NOVEL MERCHANDISING PLAN.

A rather novel method of merchandising phonographs and records is that utilized by Charles W. Bawden, Lake City, Ia., who sells Edison phonographs. Mr. Bawden's outfit consists of an arrangement whereby a cylinder phonograph can be drawn out beyond the tailboard of his two-horse wagon and played while his team stands. From house to house he goes, stopping only long enough to give a good recital and close a sale. His horses are covered with a light blanket to protect them from the flies, and thus keep them in condition to stand still as long as needed. His method is to leave an Edison machine with a number of records and call for them in a day or two.

The Crippen Co. has been incorporated at Albany, N. Y., with a capital of \$50,000, for the purpose of conducting a business in talking machines and musical instruments. Those interested are W. S. Furman, W. G. Chittick and J. A. Harway.

BUSINESS IS GOOD—THERE'S A REASON

A TRIAL ORDER WILL SHOW YOU

WHY

THE GOODS AND THE SERVICE IS THE ANSWER

The DOME RECORD CASE

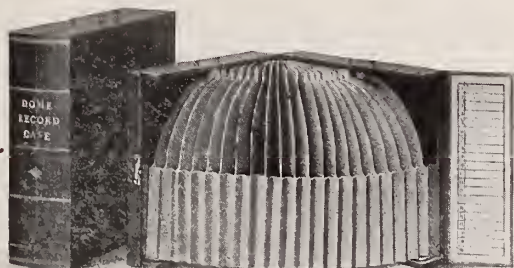

should be in your stock. Holds 20 records. Made in 10" and 12" sizes. Equipped with lock and key. Order samples to-day, with the list of records and that particular style or finish of Victrola you are unable to get elsewhere.

The completeness in filling and promptness in shipping your order will convince you we have both goods and service.

Edison and Victor Distributer

W. D. ANDREWS, Buffalo, N. Y.

Can't keep us down

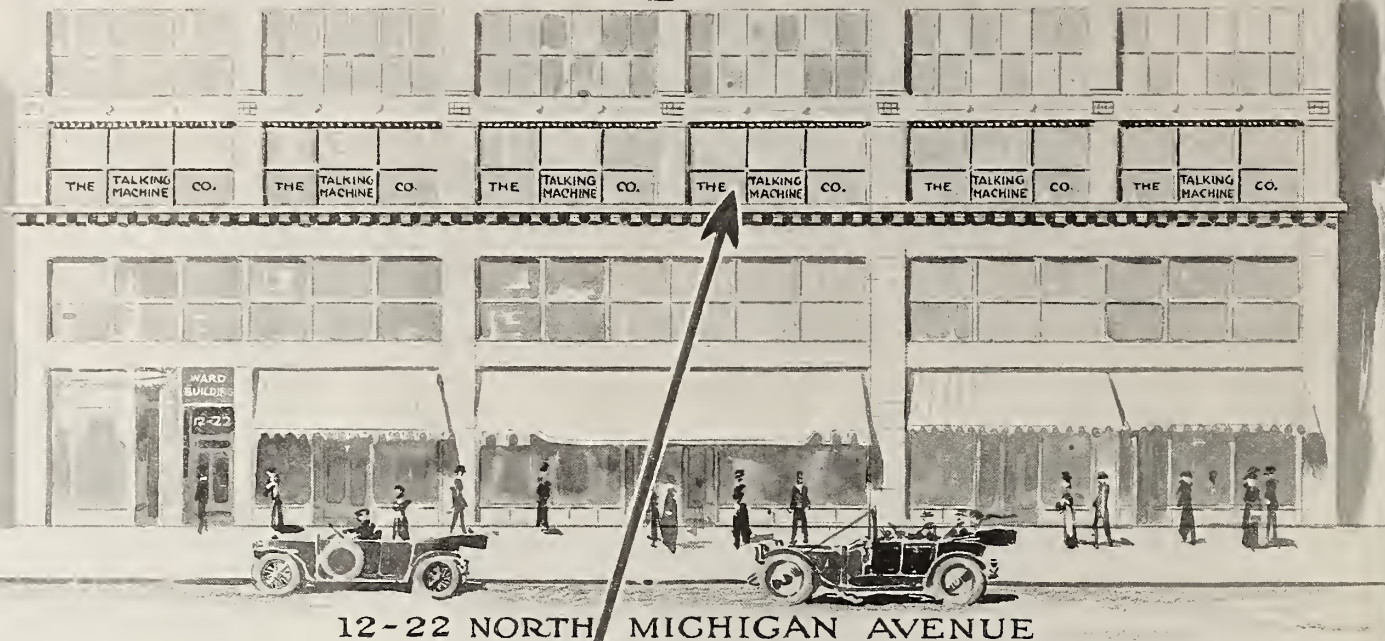

Service

has been the one Big Factor in our success!

Are You Profiting By It?

Do you realize what it means to you, *Mr. Dealer*, to throw the responsibility of taking care of you on an *exclusive wholesaler*?

Are You Taking Advantage of All Our Sales and System Ideas?

You'll be interested in our *new list* of *Biggest Selling Standard Victor Records*—an idea to help promote your Record business and prepare your stock for CHRISTMAS BUSINESS. Write for it.

Our Stock is the Largest Victor Stock in the Country

THE TALKING MACHINE CO.

12 North Michigan Avenue, Chicago



107 W. MADISON ST.

FROM OUR CHICAGO HEADQUARTERS

E. P. VAN HARLINGEN, Manager
HENRY S. KINGWILL, Associate

World Office
Consumers' Bldg. 220 South State St., Chicago
Telephone: Wabash 5774

(Special to The Talking Machine World.)

CHICAGO, ILL., November 11.—Optimism in large quantities is found prevalent in the talking machine trade of the Middle West at the present time. Jobber, dealer and supply men are united in the belief that the winter months of 1914-15 will make a record that has never been approached—war or no war.

A rather unusual but decidedly commendable feature of present trade conditions is the disposition exhibited by both jobber and dealer to carefully estimate the requirements of the holiday season unusually early and to order them delivered in plenty of time to handle.

Prophecies Big Business.

"The biggest month of the year," that is the way R. J. Keith, sales manager of the Talking Machine Co., characterized the month of October. "The business in both machines and records was tremendous," said Mr. Keith. "Almost every dealer seems to be desirous of stocking up early and heavily, and a number of them are paying particular attention to their record wants. We are anticipating the biggest holiday season in the history of the concern.

"There is a particularly heavy demand for the Victor X's and XI's and, of course, heavy calls for the new 'English brown.' This finish is proving to be exceptionally popular, and golden and fumed oaks are also receiving much attention.

"We are distributing and receiving a large number of calls for our new list of 'biggest selling Victor records.' These are made up of the records that sell best the year around, and does not include the popular numbers as used in the common sense, but contains selections which accurate statistics have shown to have most merits. These numbers are of the kind that the customer never wears of, and incidentally these records will improve the musical tastes of the person using them. There are 376 numbers in the list arranged in numerical order."

This new list of the Talking Machine Co. represents the customary monthly aid to the dealer. The Talking Machine Co. has made it a policy to turn out an actual aid of some description every month, and this latest supplement to the dealer's sales ammunition is a most effective one.

Adds Another Display Room.

The talking machine department of the W. W. Kimball Co. has, by reason of increased business

it is doing, been obliged to take more space upon the first floor. A large sound-proof room, that had been used in piano demonstrations, has been turned over to the talking machine department, and Manager T. J. Cullen is making good use of it.

"The Six Best Sellers."

Victor dealers are reporting that the six best sellers at the present time are: "It's a Long Way to Tipperary" (the marching song of the Allies); "Mary, You're a Little Bit Old Fashioned"; "Millicent"; "Along Came Ruth"; "The Castle Gavotte," and Jocelyn's "Lullaby," sung by McCormack.

The six best Columbia sellers are "Ballin' the Jack" and "Meadowbrook" (A5595); "The Old Homestead," "Dream of the Rose" (A5600); "High Cost of Loving" and "Back to the Farm"; "In Michigan" (A1592); "Land of My Best Girl" and "Where the Red, Red Roses Grow" (A1613); "It's a Long Way to Tipperary" and "Old Comrades March" (A1608); "In the Shadow of the Sycamore" and "California and You" (A1601).

Columbia Business Good.

W. C. Fuhri, district manager of the Columbia Graphophone Co., reports that business is exceptionally good, with prospects for the best November and December in the firm's history. Mr. Fuhri says that dealers are placing their orders exceptionally early this year, evidently in preparation of big sales, and that the orders are also heavier than last year at this time.

"The dance fad is holding on tenaciously," said Mr. Fuhri, "with especially big calls for 'Fox Trot' records. There is also a very heavy demand for foreign patriotic records, and in this direction the Columbia Co. is doing a tremendous business because of its comprehensive catalog of foreign selections. The style Mignonette machines which we fitted with the patented record compartment, offering easy selection of the record desired, is selling in wonderful shape and will be the popular machine, in my estimation, of the holiday business.

"I met General Manager George W. Lyle while in Kansas City recently. He was on his way back from his customary trip to the coast, and told me that he found conditions in that section of the country and in the Western States exceptionally good."

Charles F. Baer, local Columbia manager, expresses his opinion that business in this section will show a decided excess over the business last

year. Mr. Baer reports large sale of dance records and also considerable call for operatic selections. Religious records are also selling well, according to Mr. Baer, with good calls for numbers by the Chicago Preachers' Quartette and the records of Cantor Joseph Rosenblatt.

Mr. Baer reports that Albert Lurie & Co., 1810 Blue Island avenue, have taken on the Columbia line exclusively. I. Sherry & Sons, 3448 North avenue, have also taken on the Columbia line.

Installs Victor Department.

R. J. Keith, sales manager of the Talking Machine Co., recently aided in the installation of the Victor department in the large store of L. S. Donaldson & Co., of Minneapolis. L. S. Knickerbocker, formerly with the Stewart Dry Goods Co., of Louisville, is in charge of the department and has already done much constructive work upon it. At the present time he is busily engaged in work attendant upon the formal opening of the department, and plans in a short time to run a series of recitals and dancing exhibitions.

Remodel Bent Department.

The talking machine department of the George P. Bent Co. has been removed from the fourth floor to the first floor, where it is located in excellent surroundings. The new space includes, in addition to a large reception room, four sound-proof booths and a large record stock room. It is planned to remodel three of the large rooms in the back of the store into a small recital hall or theater, which will be used for the demonstration of the Cheney and Victor talking machines, and also for the George P. Bent line of pianos. The department will be under the general supervision of Retail Manager Otto Schnering, with Edwin V. Zeddes in direct charge, and C. H. Sawyer superintending the work of the record department.

Placing Orders Early.

Reports from various divisions of the talking machine industry show that great preparation is being made by the jobbers to handle what is expected to be one of the greatest holiday seasons in the history of the trade.

One indication of this is found in the large number of orders received by the Salter Manufacturing Co., 337 South Oakley boulevard, makers of the Salter felt lined cabinets.

"Our business for the last month shows that business in the talking machine trade is expected to be good judging by the large amount of orders that we are receiving," said Manager Mortenson, to the World. "Another interesting feature lies in

(Continued on page 47.)

THE WADE—THE PRACTICAL—THE WADE Fibre Needle Cutter

The WADE embodies the right principle, worked out through long experience. It is simple, durable and accurate. It trims the needle at an angle resulting in the best tone. The WADE cutters are made of the best steel and are absolutely guaranteed.

The Wade

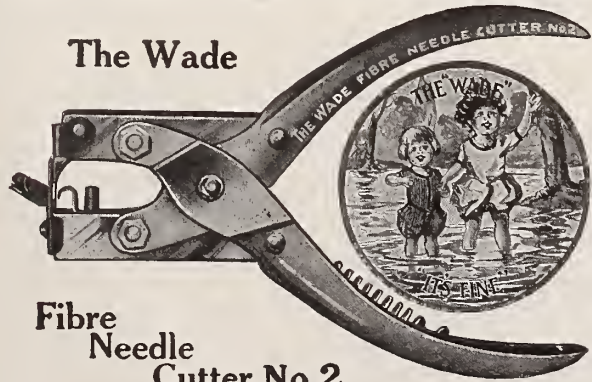

Fibre
Needle
Cutter No. 2

The WADE is the most economical cutter. It has a self-acting stop, which prevents waste and enables one to get from 12 to 15 perfect playing points. No. 2 has a double action, making it especially easy to operate and affording the most powerful cut of any tool made. No. 1 is a very popular cutter which has given excellent service.

The Wade

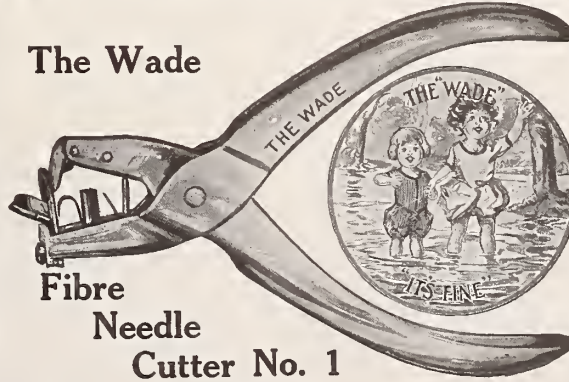

Fibre
Needle
Cutter No. 1

RETAIL PRICES—No. 1, \$1.50; No. 2, \$2.00

Order from your regular Distributor—we sell to Jobbers only

WADE & WADE,

3807 Lake Park Ave.
CHICAGO, ILL.

A SERVICE THAT DIFFERS

OUR Victor Talking Machine Department has always been a pioneer.

In many of the better methods of the present day, we led the way.

The world has not stopped spinning, progress has not ceased and now we offer a number of ideas of recent origin that work out to the great advantage of all concerned.

Send your orders for machines and records to us and let us show you how our Service differs. Let us show you how it attracts dealers wishing exceptional completeness and promptness in order filling, combined with intelligence in the execution of all commands.

Lyon & Healy

CHICAGO

FROM OUR CHICAGO HEADQUARTERS—(Continued from page 45).

the fact that they are ordering their stocks early. Last year, previous to December, we worked night and day shifts, and in spite of every effort we could bring to bear we were obliged to disappoint our customers who ordered late. Evidently they have taken the lesson to heart, for they are ordering ahead to be sure of getting their goods."

S. O. Wade, head of Wade & Wade, manufacturers of fibre needle cutters, at 3807 Lake Park avenue, makes a report that is very similar.

Mr. Wade said to the World: "In spite of what we hear about depressed business conditions, I must say that in my opinion we are looking forward to one of the most auspicious periods that the talking machine industry has ever enjoyed. We are receiving unusually large orders for holiday shipments and have been receiving these, in fact, for a considerable time past. A large number of the orders received show that dealers and jobbers are making unusually early preparation. This, of course, is as pleasing to us as it is good for them, as we were unable last year to ship their goods as promptly as we would have liked on account of the rush that came all at one time."

Will Handle Little Wonder Record.

The local sheet music store of the Waterson, Berlin & Snyder Co., corner of Monroe and State streets, will, in all probability, institute a department within the next few days devoted to the sale of the "Little Wonder" record. This record is only five and one-half inches in diameter and plays for almost two minutes. Already three or four "variety" stores in Chicago are marketing the record for ten cents.

M. M. Blackman Resigns.

The Chicago talking machine trade lost this month one of the most popular of its members in the person of M. M. Blackman. Mr. Blackman has resigned from his position as manager of the retail record department of Lyon & Healy, and has pro-



M. M. Blackman.

ceeded to Kansas City, where he will have complete charge of the Phonograph Co., Edison jobbers, in that territory.

Mr. Blackman will have excellent quarters located on Grand avenue, in that city, and will have entire control of both the wholesale and retail departments and the distribution of the Edison phonographs in Missouri, Kansas, Oklahoma, and probably a part of Iowa and a part of Nebraska.

Mr. Blackman began his acquaintance with the talking machine trade about nine years ago, and two years later secured the management of the retail record department at Lyon & Healy, in which capacity he has served up to the present time. He was very successful in the conduct of the record department due, in a great part, to his comprehensive knowledge of music, for he had studied music for a number of years, and previous to his coming to Lyon & Healy was a professor of singing.

In speaking of his new change, Mr. Blackman said to the World: "I regret very much to leave Chicago and all the friends I have here. I have

MARSHALL FIELD & CO., DEPARTMENT TO OPEN DECEMBER 1.

Harry C. Meek to Be Manager of Talking Machine Department of Big Chicago Store, Where the New Cheney Product Will Be Handled—Quarters Being Handsomely Fitted Up.

(Special to The Talking Machine World.)

CHICAGO, ILL., November 9.—E. L. Howe, merchandise manager of Marshall Field & Co., made the interesting announcement this week that the



Harry C. Meek.

new retail talking machine department of "the greatest mercantile house in America" would be opened about December 1 with Harry C. Meek as manager.

A large force of workmen is rapidly completing

been treated with the utmost kindness by all the members of the trade in Chicago, and to part from them is not easy. However, opportunity beckons and I must go. I am a great admirer of the Edison phonograph and believe that it offers great possibilities in the territory in which I am to represent it."

New Assistant at Boston Store.

B. Cook has succeeded L. F. Nelson as assistant manager of the talking machine department of the Boston store. W. S. Paton continues as buyer.

Record Business Increasing.

C. E. Goodwin, manager of the Phonograph Co., local jobbers of the Edison phonograph, is another of the optimistic-minded ones along the "Row." Mr. Goodwin says that everyone seems to prophesy a big fall, and says that as the holiday season approaches the prospect for the Phonograph Co. appears especially roseate. The retail department of the company is especially busy, and in the record department the greatly increased library is said to be responsible for this as well as some exceptionally beautiful new records.

One that is especially popular is the violin obligato with piano accompaniment, "Ave Maria" (Schubert) as played by Carl Flesch. On the reverse side of the record is to be found a short sketch of the artist making the same and a short history of the composition itself. This is played first, as a rule, and lends much enjoyment to the rendition of the piece as well as an increased appreciation of it.

Improves Store.

A. H. Dannemark, talking machine dealer of Wilmette, has built some new booths and otherwise improved his establishment in preparation for the fall trade.

Visitors and Personals.

Mr. Pierce, formerly connected with the talking machine department of Hillman's, is now in charge of a similar department for Louis Fish & Co., Sixty-third and Halsted streets.

D. A. Creed, credit manager of the Talking Machine Co., Chicago, returned recently from a sojourn at French Lick, Ind., appearing to be much improved in health. Mr. Creed has been in decided need of such a rest following a long period of strenuous work, and he now feels in shape to face the coming season.

E. K. Andrew, in charge of the talking machine department of the J. L. Hudson Co., of Detroit, was a recent visitor to Chicago, and while here arranged for the improvement of his department.

L. C. Parker, manager of the talking machine

the new section and the holiday season will find patrons of Marshall Field & Co. inspecting one of the finest departments of its kind in the country.

Although a young man, Mr. Meek is the possessor of considerable experience in the talker field, beginning his knowledge of the business in the retail department of the Rudolph Wurlitzer Co. some eight years ago. Later he became a member of the traveling sales force, doing considerable traveling in the West and Middle West. Mr. Meek then became manager of the piano and talking machine departments of Eberhardt, Hayes & Co., of Wichita, Kansas, and after gaining a valuable experience with that company returned to "road" work. Mr. Meek came to Chicago three years ago and after working for the P. A. Starck Piano Co. for about a year as manager of the talking machine department became associated with the Geo. P. Bent Co., with which concern he has been up to the present time.

Mr. Meek expresses great admiration for the new Cheney machine which, together with the Columbia, will constitute the lines handled, and is already hard at work upon plans for their proper presentation to the Chicago public. He is now engaging members of the sales force and hopes to have, by the time the section is opened, an organization of ability and reputation.

department of Gimbel Bros., Milwaukee, was in Chicago this week and took visible pleasure in reporting that his sales of the past year have shown an increase of 50 per cent. over the previous year's business. Mr. Parker says he is another one of the many optimistic dealers who say that the holiday season of 1914 will break all records.

Members of the local trade have been interested in discovering that W. C. Griffiths, floor salesman of the Talking Machine Co., is a brother to H. T. Griffiths, the very able sales manager of the Udell Works, of Indianapolis.

F. R. Cassidy is a new salesman in the dictaphone department of the Columbia Graphophone Co., and is doing good work under the direction of W. W. Parsons.

New Needle Concern.

Emil Ad Wenglein has opened an office in the Royal Insurance building at 160 West Jackson Boulevard, from which location he will distribute a comprehensive line of talking machine needles of the H. J. Wenglein German products. Mr. Wenglein reports sales of tremendous quantity of these needles and expresses his regret to the trade that additional shipments are being received but slowly on account of the war.

Give Movie Dancing Demonstration.

The Talking Machine Shops was the first local concern to give dancing demonstrations in Chicago. The firm now sets another pace by reducing the cost, but retaining the advertising value by substituting a moving picture show which illustrates the latest dances. Every afternoon between 2 and 3 one can find about fifty patrons of the firm watching these films and getting pointers on the proper steps, at the same time listening to the seductive strains of a Victrola and the solicitation of several polite and capable saleswomen.

STRIKING WINDOW DISPLAY.

That Made by Chase & West, of Des Moines, Ia., During Newspaper National Display Week Has Come in for a Large Degree of Praise from Critics.

Chase & West, the Victor talking machine distributors of Des Moines, Ia., prepared a very striking window display of Victor merchandise which was made for the Newspaper National Display Week. The window was the subject of much favorable comment by the local newspapers, and emphasized afresh the enterprise of this prominent house in keeping their name and their goods before the public so effectively.

FROM OUR CHICAGO HEADQUARTERS—(Continued from page 47).

SYSTEMATIC METHODS RULE LYON & HEALY SERVICE.

Recent Improvements Made in Arrangements for Filling and Handling Orders—How Shipments Are Facilitated—Some Interesting Views of the Lyon & Healy Department.

(Special to The Talking Machine World.)

CHICAGO, ILL., November 10.—Lyon & Healy Victor service, always noted for its efficiency, has been further strengthened this fall in various ways. One feature in particular which enables them to fill record orders promptly, accurately and completely is shown in the accompanying view of a section of the wholesale record department, showing the order fillers at work. It will be noticed that the workers are disposed at four different

express orders received up to 5 p. m. will leave the city that evening.

Never in their history have the Victor advertisements published in the Chicago dailies been of such a thoroughly artistic and effective character as at present and the mats of these advertisements in different sizes to meet the requirements of the dealers are at the disposal of the latter for their own holiday advertising.

These advertisements are prepared by the Lyon

board advertising can obtain the poster in eight-sheet form at the actual cost of production. The window posters and poster stamps are furnished free to Lyon & Healy customers.

Another feature of the Lyon & Healy service which works particularly to the advantage of the dealers in the pre-holiday season is the fact that the inquiries received by the house from out of town are referred to the nearest Lyon & Healy dealer.

Manager L. C. Wiswell of the talking machine department of Lyon & Healy says that their wholesale business for October and so far in November shows a material increase over the corresponding period of last year. He has just returned from a trip to the Victor factory where he found everybody highly satisfied with the business being received from all over the country.

GRAND RAPIDS DEALERS ORGANIZE.

Form Association for Business Betterment with Julius A. J. Friedrich as President.

(Special to The Talking Machine World.)

GRAND RAPIDS, MICH., November 9.—Talking machine dealers of Grand Rapids held a meeting recently at the Livingston Hotel at which they formed an association designed for the betterment of the talking machine situation in this city, Julius A. J. Friedrich was elected president; M. M. Merrin, vice-president, and H. B. Williams, of the Wuerzberg Dry Goods Co., secretary and treasurer. George P. Cheatle, traveling sales manager of the Talking Machine Co., of Chicago, was present and assisted the dealers materially in the work of forming the new body. The association will work for the improvement of conditions surrounding the question of charging interest on deferred payments, and it is believed that conditions will be vastly improved.

Regular meetings will be held once a month.

A HANDSOME WINDOW DISPLAY.

Victor Machines and Records Featured Attractively in Its Spacious Show Windows by the Schmidt Music Co., Davenport, Ia.

(Special to The Talking Machine World.)

DAVENPORT, IA., November 9.—The Schmidt Music Co., which features the Victor machines and records, had a most interesting window display in the windows of its store which, according to the officers of the company, produced more real results than any previous display featured by the company.

The window was divided into three sections, with the large middle section taken up by a miniature reproduction of the stage of the New Amsterdam Theater, New York, accompanied by the statement that the music of the many light opera successes presented at that playhouse were to be found in Victor records.

In the left hand section of the window were shown several photos, in colors, of Mrs. Vernon Castle, the celebrated society dancer, with the Victor dance records suitably presented. At the right was shown a Victrola XI.

It is estimated by the company that over 10,000 people stopped and inspected the exhibit while it was in the window and a good proportion of them came into the store for the purpose of making inquiries or purchases.

TALKING MACHINE IN THE SCHOOL.

(Special to The Talking Machine World.)

LAUREL, MD., November 9.—A most delightful entertainment was recently gotten up by Prof. H. P. Mitchell, principal of the local high school, in which the Columbia Princess Grafonola played an important part, R. H. Sadler, Jr., presenting a number of selections on this instrument which were interspersed throughout an interesting program of instrumental and vocal music in which the pupils participated. The friends and parents of the pupils were present, as well as Prof. Mitchell, who were quite enthusiastic in their praise of the Grafonola as an aid to school entertainment.



Lyon & Healy Force Filling Record Orders.

counters. At one of the counters the freight shipments are cared for, at another the express shipments, at a third, orders are going by parcel post and at a fourth the city wholesale orders are handled.

This division of the work is proving wonderfully effective, expediting the business wonderfully, avoiding confusion and loss of time and eliminating errors.

The view of a corner of the machine stock room gives just a suggestion of the immense stock car-

& Healy advertising department and distinctive exploitations of Victor goods.

The Lyon & Healy Victor posters have become famous in the trade. A new one has just made its appearance. The size for the dealer's store and window displays is seventeen and a half by twenty-three inches. It is artistically printed in red, yellow and green and their combinations. It is a young woman gazing with admiration at a \$200 Victrola which occupies the foremost place among the family holiday gifts with a very expansive and



Lyon & Healy Machine Stock Room.

ried. Much of the freight shipments of machines are now made from the big surplus stock carried at the new factory at Healy Station, where the goods are loaded direct on the cars, avoiding hauling entirely.

Lyon & Healy have reduced the shipping problem to such a science that they can ship all orders received up to 1 p. m. the same day and all

richly ornamented Christmas tree in the background. The legend reads, "The great gift is surely a Victrola. Come in and hear it."

This poster has been reduced to the size of a "poster" stamp for affixing to letters and packages. Lyon & Healy are sending out two tablets of 320 stamps each to their dealers for affixing to packages and letters. Finally, those dealers who do bill-

FROM OUR EUROPEAN HEADQUARTERS

2 GRESHAM BUILDING, BASINGHALL STREET E. C., LONDON, W. LIONEL STURDY, MANAGER.

Business Outlook Steadily Improving—Public Has Recovered Its Optimistic View of Things—Gramophone Trade Shows a Falling Off of About 33 Per Cent.—Situation Reviewed—Shortage of Supplies Has Delayed Manufacturing—Better Shipments of Motors from Switzerland Relieving the Local Trade—Enormous Demand for Patriotic Records—Many Members of the Talking Machine Trade Have Joined the Military Forces—General Trade News of the Month.

(Special to The Talking Machine World.)

LONDON, E. C., ENGLAND, November 5.—Special inquiry around the trade this month elicits pleasing information apropos general sales conditions. Under present circumstances we cannot hope to enjoy normality in any sphere of industrial activity outside, of course, the supply of what may be termed war products. But, largely as the result of official advice and example, the business outlook is steadily improving; the public has recovered its optimistic view of things and is gradually opening its purse to the extent of expenditure even upon luxuries. What this means to the gramophone dealer can be fully appreciated when I say that sales were so slack in August that quite a number contemplated the possibility of closing their doors. Fortunately this has become unnecessary. With the issue of big patriotic record lists by all the London houses, and a partial renewal of advertising, trade leaped forward at an astonishing rate, progressive sales being announced from all centers. Leading gramophone men are agreed that, all things considered, record sales are really very satisfactory. To present World readers with a clear idea of the position, I personally interviewed a number of record manufacturers and find that opinion generally agrees with the foregoing statements. Gramophone trade last year was exceptionally good. In comparison I estimate we are down about 33.3 per cent. so far this year, which is not bad. Reports, of course, vary from 25 to 50 per cent., but the average trade loss is not more than a third on the record side. Instrument trade is seriously affected by lack of supplies, and in this section I have no doubt the loss is much heavier. Even if supplies were obtainable machine sales would not be much better than at present, because new buyers are not so easily found these days. There is, however, an evident want of cheap instruments, particularly by the large mail order firms, whose business in this department is almost entirely held up. Large quantities of motors recently received in this country from Switzerland will doubtless relieve the situation just as soon as arrangements can be made for adequate supplies of tone-arms, sound boxes and trumpets. Of these we are await-

ing the pleasure of British manufacturers, who, if somewhat slow to act, are nevertheless gradually moving in the matter of their production. The chief difficulty seems to be on the question of price, which has, so far, not been brought low enough to offer the possibility of making the capture of Continental trade permanent. All things come to those who wait, and I have good grounds for reporting that the trade may soon be able to congratulate itself upon being able to list every description of gramophone products as made in England.

An Important Copyright Action.

Chappell & Co., Ltd., vs. Columbia Graphophone Co., Ltd.—The plaintiffs owned the copyright in the music of the song "Where My Caravan Has Rested," the author, Herman Löhr, having assigned his rights to them before the passing of the copyright act, 1911. They published the song with pianoforte accompaniment. After giving them due notice of their intention to reproduce the song on gramophone records, the defendants obtained a copy, set it to orchestral arrangement and made records. They paid the author the royalties he was entitled to under the act of 1911. Plaintiffs brought an action to restrain the defendants from making copies of the music without their consent, and for delivering up of copies and damages. Defendants submitted that they had only done what they were entitled to do under the act. The parties admitted that before the act of 1911 it would have been a breach of the plaintiffs' copyright to make a copy of the music for the purpose of producing an orchestral accompaniment. At the trial Justice Neville decided that the act gave a limited right to the author or owner of a musical work in respect of reproduction on records. In the case of an assignee before the act this right was given to the author and not to the assignee, and the act did not affect or diminish the copyright of the assignee. Notwithstanding the right of protection given to the author in respect of records, what the defendants had done was an infringement. The plaintiffs therefore succeeded. From this decision the defendants now appealed, and the court held that the appeal failed.

New Companies Incorporated.

Bulldog Record Co., Ltd.; capital, £1,000; registered office, Milton House, 35 Surrey street, Strand, London, W. C.

Wallace Harris, Ltd., musical instrument dealer; capital, £10,000; office, Harris Building, 42 East-gate street, Gloucester.

The Scala Co. Opens a Provincial Branch.

The northern counties of England have been well described as the mainstay of the record trade. It is not surprising, therefore, to observe a tendency on the part of London houses to establish

separate depots "up North" in order to centralize stock for quick delivery. The latest to spread its wings is the Scala Record Co., Ltd., who announce the opening of a new branch at 56 Miller street, Manchester, where will be carried a complete stock of British-made Scala records and a full line of gramophones and accessories.

Gramophones in the Trenches.

According to a press report, Sundays are usually pretty active days for the troops, but October 4 was an exception. A graphic description from the front says, in part: "Opposite one portion of the line the enemy's bands played patriotic airs, and the audiences which gathered gave a chance to our waiting howitzers. Not only do their regimental bands perform occasionally, but, with their proverbial fondness for music, the Germans have in some cases got gramophones in their trenches."

Talking Machine Addresses Conventions.

Two important conventions have recently been addressed by the talking machine. The first was the Bread and Cake Manufacturers' Association of Canada at its convention in Winnipeg on September 9; the second was the National Association of Master Bakers, its convention being held in Richmond, Va., on October 20. In both cases the novelty of the proceeding and its immense possibilities were most enthusiastically commented upon, and many were the complimentary remarks made as to the excellence of the reproduction, this latter being a tribute to the National Gramophone Co. (1913), Ltd., who made the records. One of the world's leading experts in flour and bread making, an Englishman, Mr. Jago, had been invited to address both conventions. Being, unfortunately, prevented from crossing the "herring pond," he decided upon this attractive method of speaking to the delegates. The address to the Winnipeg convention, which occupied ten minutes to deliver, was placed upon one double-sided 10-inch record; the address to the Richmond convention, occupying fifteen minutes, was given on one double-sided 12-inch record. We need not, perhaps, remark that only by means of the Manadon patent process could such an extraordinary length of playing time be secured in the compass of one disc.

Columbia Co.'s £750 Royalties.

Probably no trade announcement has ever caused greater satisfaction than the Columbia Co.'s intimation on the issue of its first war records that it would pay a royalty on each record sold to the Prince of Wales' National Relief Fund. If it needed courage to issue new records at a time when this country had possibly its gloomiest outlook before it, as seemed to be the case commercially during the first two or three weeks of the war, then how much greater courage was needed

(Continued on page 50.)

"RENO, THE MAN OF MANY PARTS"

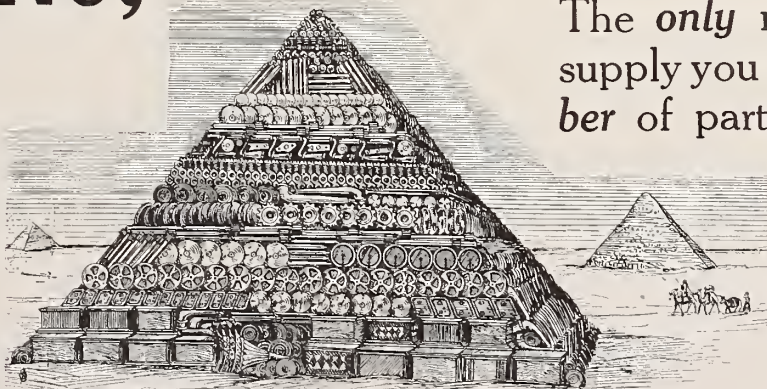

The *only* man in the world who can supply you with *one* part—or *any number* of parts for *any* Talking machine ever made from Adam to Edison-Roosevelt.

64 Page Catalogue Yours for Asking

W. H. REYNOLDS, Ltd.
"KNOTASLEPE"
London, England

FROM OUR LONDON HEADQUARTERS—(Continued from page 49).

to say that in connection with those records—a daring experiment in themselves—a royalty would be paid to the Prince of Wales' Fund?

As it happens, these war records came at a psychological moment, when the trade was having the impression thrust upon it that the public had set aside their gramophones for what looked like being a long rest. But with the issue of these war records by the Columbia Co., and the accompanying announcement regarding the special royalties to the Prince of Wales' Fund, public interest was awakened, and dealers throughout the country enthusiastically leaped at the idea of helping this deserving fund in this ingenious but decidedly practical fashion.

So whole-heartedly did the trade and public seize upon the suggestion that in purchasing these war records they were contributing to the Prince's fund that by October 26 the Columbia Co. had been enabled to send checks to the organizers of the fund amounting to £750.

Dutch Inquiry for Gramophones.

Inquiries for British-made goods continue to reach this country through various channels from all parts of the (neutral) world. The latest to hand is from the British consulate at Amsterdam, Holland, reporting that good scope exists for the development of British trade in that country, and citing an application from a firm in Amsterdam which desires direct communication with British houses manufacturing all kinds of musical instruments, gramophones and records being especially mentioned. The Commercial Intelligence Branch of the Board of Trade, 73 Basinghall street, London, E. C., will be pleased to furnish the necessary details to any genuine British manufacturing house upon application.

Export Trade Prospects.

Increased shipments of gramophone goods are being made from London to all parts of the world, the campaign on behalf of all-things-British having borne good fruit. Our manufacturers fully appreciate the opportunity now available for the development of trade overseas, and it is pleasing to observe that their efforts have secured unstinted

co-operation from colonial traders. It has been impressed upon me that the local requirements of different markets is receiving special attention, with a view to the permanent retention of oversea patrons.

Records for Wounded Soldiers.

That the gramophone is taking a high place among the comforts of our wounded soldiers in hospital is evident from the reception of gifts of records to those institutions. A few weeks back the manufacturers of Regal records received a letter of thanks from the matron of the London Hospital, which so aptly illustrates the point that we can hardly do better than quote it: "The matron desires to convey her sincere thanks for the very generous supply of records which we have just received. The patients are thoroughly enjoying the tunes already and we are most grateful to you for being the means of giving the wounded soldiers some happy hours."

A Big Selling Record.

The Daily Mail recruiting song, "Your King and Country Want You," has been paired with the Daily Chronicle song, "Fall In," on Regal record No. G6815. As these are probably the two most heavily boomed war songs of the moment, each having behind it the influence and strength of the most important newspapers of the day, this record should be one of the biggest sellers of the time.

Proving a Big Seller.

"Tipperary" figures as march with vocal choruses by Harrison Latimer on Regal war record No. G6802. On the reverse of the disc is "Red, White and Blue," similarly treated.

Belgian and British Soldiers Make Record.

A descriptive record of more than ordinary interest is that announced on the new Regal war list under the title "Arrival of the British Troops in France." The record occupies both sides of a ten-inch disc, the first half depicting the approach of the troopship to land, with soldiers singing and bands playing, the exchange of chaff, the welcoming shouts of "Vive les Anglais," the answering British cheers, an inspiring speech to the men and the "Fall in" as the boat draws alongside. The

second part illustrates the disembarkation, the lowering of the gangway, a rousing chorus which our soldiers have made their own for keeping in step, followed by the marching off of battalions of the Grenadiers, the Gordons and the Irish in succession, good-hearted banter and the entraining "for the front," the record coming to a brilliant conclusion with the departure of the train amid hissing of steam, singing of "The King" and volleys of cheering.

It is interesting to learn that among those who took part in the making of this record were a number of British territorials and four Belgian refugees, who entered thoroughly into the spirit of the occasion.

The Toll of War.

Accompanied by his wife, an American lady whom he had only recently married, Arthur Nier, of Nier & Ehmer, the German firm of horn manufacturers, left New York on July 25 and got through to Berlin just in time to join his regiment. An authentic report received in London now speaks of his death on the field of battle somewhere in France. I also hear that Clemens Humann, the Leipzig tone-arm maker, has been wounded. Another casualty is that of the eminent violinist, Fritz Kreisler, who lies in a Galicia hospital suffering from a serious wound in his leg and a slight one in his left arm, which latter, the doctors say, will fortunately not incapacitate him from continuing to exercise his art.

"H. M. V." People in the Fighting Line.

Some 200 members of the Gramophone Co.'s staff have joined the army to fight for old England, and some at the front find time occasionally to send through a line or two and their experiences. Lieut. Jack Gibbons, A. S. C., writes: "I have been up to the firing line twice in charge of a convoy of twenty-five motor lorries filled with ammunition. . . . leaving to-day for the firing line for good. That means I shall be attached to an 'ammunition park' . . . right in the thick of it."

Sergeant Cowen says: "I tried to catch a shrapnel." (Continued on page 51.)



"His Master's Voice"

Copyright

This intensely human picture stands for all that is best in music

—it is the "His Master's Voice" trade-mark, and it brings to you, no matter where you are, the very best music of every kind, sung and played by the world's greatest artists — the greatest singers, pianists, violinists, orchestras and bands—all enshrined in the unequalled "His Master's Voice" records.

'His Master's Voice'

—the trade-mark that is recognized throughout the world as the

HALL-MARK OF QUALITY

Branches

AUSTRIA: Oesterr. Grammophon-Gesellschaft, m.b.H.L., Graben 29 Vienna, Austria.

BELGIUM: Cie. Française du Grammophone, 51, Avenue de la Porte de Hal, Brussels.

DENMARK: Skandinavisk Grammophon-Aktieselskab, Frihavnen, Copenhagen.

FRANCE: Cie. Française du Grammophone, 115 Boulevard Richard Lenoir, Place de la République, Paris.

GERMANY: Deutsche Grammophon-Aktiengesellschaft, 35, Ritterstrasse, Berlin.

HUNGARY: The Gramophone Co., Ltd., Kosuth Lajos-Utca 8, Budapest.

SPAIN: Cia. Francesa del Grammophone, 56, Balmes, Barcelona.

SWEDEN: Skandinaviska Grammophon-Aktiefelaget, Drottning Gatan No. 47, Stockholm.

RUSSIA: The Gramophone Co., Ltd., 45, Nevsky Prospect, Petrograd (St. Petersburg); 9, Golovinsky Prospect, Tiflis; Nowy-Swiat 30, Warsaw.

INDIA: The Gramophone Co., Ltd., 139, Bal-laghata Road, Calcutta; 7, Bell Lane, Fort, Bombay.

Agencies

AUSTRALIA: S. Hoffnung & Co., Ltd., Sole Concessionaires of The Gramophone Company, Limited, 163, Pitt Street, SYDNEY.

NEW ZEALAND: Messrs. E. J. Hyams & Co., Post Box 45, WELLINGTON.

SOUTH AFRICA: Messrs. Darter & Sons, Post Box 174, Capetown; Messrs. Mackay Bros., Post Box 251, Johannesburg; Messrs. Mackay Bros. & McMahon, Post Box 419, Durban; Ivan H. Haarburger, Post Box 105, Bloemfontein; Franz Moeller, Post Box 108, East London; Messrs. B. J. Ewins & Co., Post Box 86, Queens-town; Messrs. Handel House, Kimberley; Messrs. Laurence & Cope, Post Box 132, Bulawayo; The Argus Co., Salisbury.

EAST AFRICA: Bayley & Co., Lourenzo Marques.

HOLLAND: American Import Co., 22a, Amsterd Veerkade, The Hague.

ITALY: Messrs. A. Bossi & Co., Via Orefici 2, MILAN.

EGYPT (Also for the Soudan, Greece and the Ottoman Empire): K. Fr. Vogel, Post Box 414, ALEXANDRIA.

Great Britain:

The Gramophone Company, Ltd.

21 City Road

London, E. C.

nel shell, with the result that my hands were knocked about a bit." Such is war, or rather a sidelight thereof.

T. Edens Osborne a Live Wire.

From recent Belfast papers to hand we observe that Thomas E. Osborne, the local dealer in "H. M. V." and other goods, continues to pin strong faith in the value of publicity as a sales stimulant, and in this connection we would respectfully commend his example to those manufacturers who seem suddenly to have lost faith in printers' ink. How can "business as usual" apply if one doesn't "carry on" as usual?

News of Henry E. Parker.

Since interest in Parker, P. C., seems to have been very properly overshadowed by Parker, R. H. A., I deemed it expedient to make some inquiry into the matter of the latter's confrere this side. As a gunner in the Essex battery of the Royal Horse Artillery, Henry E. Parker expects to be included among the next complement for the fighting line, although such is the necessity for secrecy in these matters that the troops are often quite in the dark as to future movements. In an amusingly written epistle to the Columbia Co. Mr. Parker emphasizes his proficiency in the vocal exercise of telling what a long, long way it is to Tipperary, and was immediately invited to make a record of this now famous song. Apropos Tipperary, I understand the record as recorded in London will be issued by the Columbia people in America. It will doubtless be very much in demand, but your dealers will find it a "long, long way" to catch up to the sales figure for the United Kingdom—over 100,000.

New Catalogue of Edison-Bell Gramophones.

A batch of well-printed and attractive publicity literature is to hand from J. E. Hough, Ltd., of Edison-Bell fame. Dealing with the new instrument catalogue we find listed over twenty different models of every variety in style and price. For instance, be there a demand in your locality for cheap exterior-horn instruments, you would find of interest Model No. 1, at 35 shillings, put up in solid oak case with graceful molded base, size 13

Merely A Statement of Fact

The British Colonies and dependencies import annually many thousands of pounds' worth of gramophone products, a large percentage of which emanated from Germany.

Now that this source of supply is cut off, who is going to fill the breach?

This question must give British houses food for profitable thought.

But the opportunity for action is not tomorrow or the day after, it is Now!

The trade routes are open and we venture to think will so remain.

You can get into touch with oversea buyers through the medium of this trade newspaper, which enjoys a wide sale throughout the world.

Particulars and advertising rates will be gladly supplied to all interested by our European representative.

W. LIONEL STURDY

2 Gresham Buildings

Basinghall St., London, E. C.

x13x7½ inches, 10-inch turntable, speed indicator, a good motor to run a 12-inch record, nicked taper tone arm (taking either needle or sapphire sound box), new Corona "Prince" sound box, 20-inch bell flower-horn in colors. That sounds good value, and it is. Passing Model 2 at £2 12s. 6d., and Model 2B at 3 guineas, we come to No. 3 at £3 12s. 6d. This instrument weighs twenty-two pounds, is equipped with solid oak or mahogany French polished cabinet with hinged cover, a three-record motor with speed and regulating device, a heavier but same style tone arm as above described for Model No. 1, Corona "Prince" sound box and steel spun 23x24½-inch flower-horn. Another good line is Model 4C at 6 guineas, carrying the following specifications: Heavily molded solid mahogany cabinet, size 16½x16½x8½ inches; double-spring, nickel plated worm-gear motor, 10-inch turntable, speed indicator, heavy nickel tapered tone arm, Corona "King" sound box, 22½x24½ inches; highly polished laminated mahogany jointless horn, giving a particularly bright and mellow tonal delivery.

Of the hornless or portable type gramophone there is illustrated a good variety from 32s. 6d. upward to £10. The general finish and workmanship put into even the cheapest model is surprisingly good, and, price considered, each instrument represents a maximum of value.

In cabinet gramophones the Edison-Bell people have produced a set of models artistic in appearance and design without sacrificing tonal quality at the expense thereof. They range in price from £9 to £21. The subjoined specifications applying to Model No. 26 will convey some idea of the remarkable value offered for 10 guineas: Beautifully designed oak cabinet, inlaid satinwood and piano polished, measuring 43 inches high by 18¼ inches wide by 20½ inches deep; concealed horn, roomy cupboard for records, powerful nickel-plated five-record motor, tapered tone arm, with the "King" duplex sound box to play needle and phono-cut records.

Another E. B. catalogue gives illustrations and particulars of some newly designed record cabi-

(Continued on page 54.)

EDISON BELL-V F-VELVET FACE



JOHN BULL AT WAR

Patriotic Records

10-in. Double Side 2/6 each

- 1409 Landing of the British Army in France, Pt. 1 Descriptive
- 1410 Landing of the British Army in France, Pt. 2 "
- 1411 Tommy Atkins Robert Howe
- 1412 The Lads in Navy Blue " "
- 1413 Sons of the Sea " "
- 1414 Soldiers of the King " "
- 1415 Jack's the Boy " "
- 1416 The Anchor's Weighed Alan Turner
- 1417 La Marseillaise and The Red, White and Blue Robert Howe
- 1418 Hearts of Oak, and God Save the King " "
- 1419 Boys in Khaki, Boys in Blue Stanley Kirkby
- 1420 Your King and Country " "
- 1421 Need You " "
- 1422 Here's to the Day " "
- 1423 For King and Country " "
- 1424 La Marseillaise, and The Russian National Anthem, London Regim'l Band
- 1425 Rule Britannia, and God Save the King London Regimental Band
- 1426 Regimental Marches of the Brigade of Guards (Slow) Band of H.M. Irish Guards
- 1427 Regimental Marches of the Brigade of Guards (Quick) Band of H.M. Irish Guards
- 1428 British Empire March Band of H.M. Irish Guards
- 1429 Steadfast and True, March London Regimental Band
- 1430 London Regimental Band

- 1403 Your Heart will Call Me Home Charles Corpton
- 1404 Since Last We Met " "
- 1405 The Girl I Mean to Make My Wife (March Intermezzo) Royal Court Orchestra
- 1406 Mam'selle Tra-la-la (Waltz) Royal Court Orchestra
- 1407 Temple Bells ("Indian Love Lyrics") Miss Mabel Mann
- 1408 Less Than the Dust ("Indian Love Lyrics") Miss Mabel Mann
- 1409 In an Old-Fashioned Town Miss Mabel Mann
- 1410 Three Fishers " "
- 1411 St. David (Welsh Patrol) Band of H.M. Irish Guards
- 1412 Wearing of the Green (Quick March) Band of H.M. Irish Guards
- 1413 Clever Mr. Green (Patter Song) Harry Bluff
- 1414 The Waiter (Patter Song) " "

12-in. Discs Double Records 4/-

- 640 Inflammatus ("Stabat Mater") Band of H.M. Irish Guards
- 641 Cujus Animam ("Stabat Mater") Band of H.M. Irish Guards
- 642 March of the Knights of the Holy Grail ("Parsifal") Band of H.M. Irish Guards
- Overture "Rosamunde" Band of H.M. Irish Guards
- O Rest in the Lord Miss Jessie Broughton
- O Divine Redeemer " "

IF YOU ARE INTERESTED SEND FOR FULL CATALOGUES TO

EDISON BELL WORKS, Glengall Road, London, S.E.

J. E. HOUGH, Ltd., Proprietors

SALES POLICY.
DISTRIBUTORS,
JOBBER
AND DEALERS.



EXCLUSIVE
PROPOSITIONS
(FOR DISTRIBUTORS
AND JOBBER)
ENTERTAINED.

Hoffay's Gramophone is Bound to be a Success WHY?

Your record stock will move more rapidly if you sell your records by means of this MUSICAL Instrument.

You can fill every flat of a house—every home—with one of these UNIVERSAL Instruments, thus establishing a UNIVERSAL buyer of ALL makes of records in every flat; all Instruments can be played at the same time, the soft, clear, natural reproduction does not go through the walls and floors, no matter how "loud" it is inside the flat.

The reproduction is free from any metallic tinge.

SELL RECORDS OF ALL MAKES

Increase your profits and those of all record manufacturers.

DESCRIPTION OF OPPOSITE PAGE

Fig. 1. Shows in section the Hoffay Sound-Box. Notice therein that the diaphragm is vibrated by a strong THREAD, which is kept stretched by the forks of the lever, the latter being in this way strengthened, thus making a fully braced structure. This accounts for the wonderful faithfulness of the reproduction. The same degree of braced structure is obtained in every Hoffay Sound-Box by means of a special tool (for which a patent has been applied), thus ensuring a standard of tonal efficiency. Also notice in Fig. 1 that the lever is rigidly supported by a ring carrier, which is free from metallic contact with the casing of the Sound-Box, insulated by a rubber ring, which is under lateral compression; in this manner the ring carrier is solidly supported without affecting in the least the vibratory action of the lever. The combined action of this rubber mounting at one end of the lever and the THREAD vibrating the diaphragm at the other end is so *sensitive* and balancing to one another that the sounds are reproduced as if in "relief" and "separated" from each other; the reproduction is *full, round, natural* and loud enough to be heard in a Theater if desired; at the same time it is of such a quality as to make it a pleasure to listen to it in the smallest of rooms.

Fig. 5. Shows the same Sound-Box with the difference that the diaphragm is connected to the forks of the lever by a screw, the result being to obtain a reproduction of great quality and as "loud" as you may wish.

Fig. 2. Shows the Hoffay Sound-Box Mounting in a

"closed" condition proper for playing records of the zig-zag type (Victor, Columbia, Odeon, etc.). Light in weight, small in size, and efficient in every respect.

Fig. 3. Shows the Hoffay Sound-Box Mounting in the "transition" condition, before swinging the block which holds the Sound-Box to position shown in Fig. 4 without having to detach the Sound-Box.

Fig. 4. Shows the Hoffay Sound-Box Mounting in an "open" condition, proper for playing records of the "hill and dale" type (Edison, Marathon, Pathe, etc.). In every case (Figs. 2 and 4) the structure is very rigid, so that no "rattling or vibration" takes place.

Fig. 6. Shows the Hoffay Sound-Box Mounting does. Either whilst playing "zig-zag" records or "hill and dale" the stylus (26) touches the *same point* on the record without any further alteration. Also notice that the angle of the stylus, in comparison with the record, remains the same in both cases; this means that AT LAST the successful use of a DIAMOND for playing the zig-zag (Victor [His Master's Voice], Columbia) is TO HAND, thus utilizing one point for playing *every* record ever made.

Fig. 7. Shows the Hoffay Tone-Arm Mounting and Weight Counterbalancing Tone-Arm. The tone-arm moves "horizontally" round the "upper" carrier and "vertically" round the "lower" carrier, shown in dotted lines, in alignment with the counter-weight. The tone-arm is straight, the weight is just "right," and the scratching of the needle is practically done away with.

J. HOFFAY

P. O. Box No. 1249

New York City, U. S. A.

Address in England: 67 Egerton Gardens, South Kensington, London, S. W.

For comparison of sizes: "His Master's Voice Goose Neck" and the "Hoffay's Sound-Box Mounting" fitting a gramophone of that or similar type.

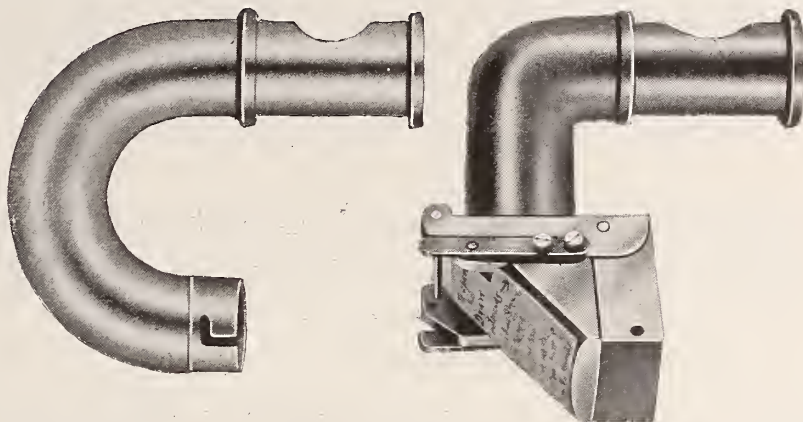

Retail Price
\$6.50

Place orders at once, stating "make" of reproducer to hold.

AN "INSIDE" GLIMPSE INTO
HOFFAY'S
"The World's Musical Instrument"
GRAMOPHONE

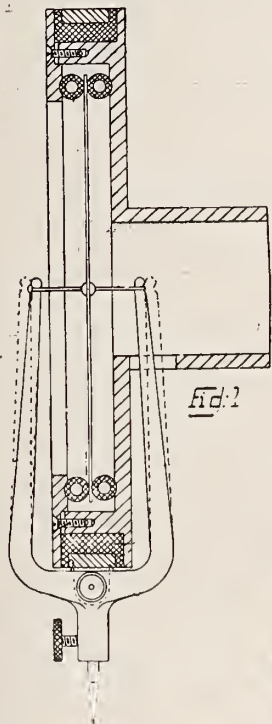

Fig. 1

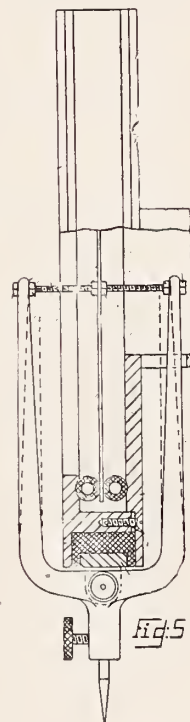

Fig. 5



Fig. 2.

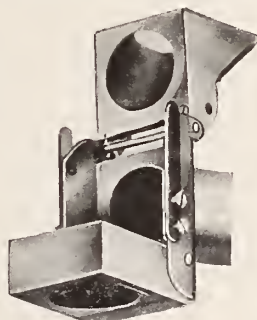

Fig. 3.

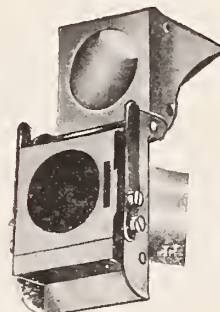

Fig. 4.

RETAIL PRICES: Sound-Box (Fig. 1) with Sound-Box Mounting (Fig. 2) Nickeled, \$18.50; Oxydized, \$20.00; Gold-Plated, \$22.50. Made to fit machines of ANY make. Sound-Box Mounting, sold separately, \$6.50. Sound-Box sold separately, deduct \$6.50 from prices as above.

Usual Trade Discounts.

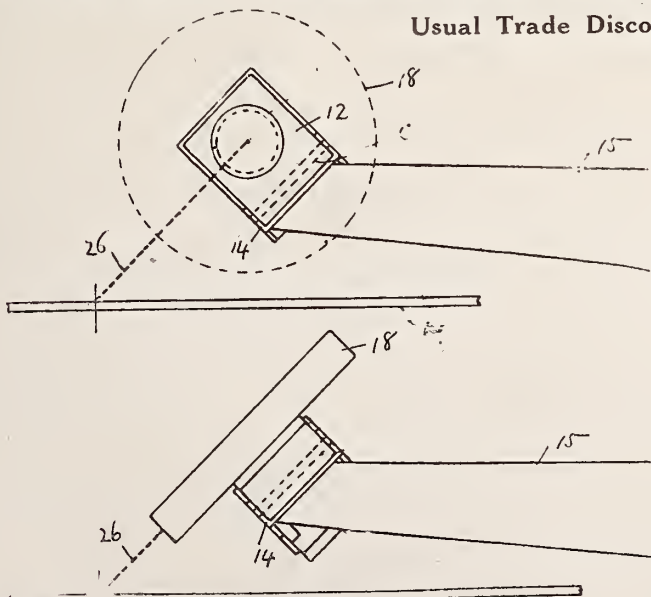

Fig. 6.

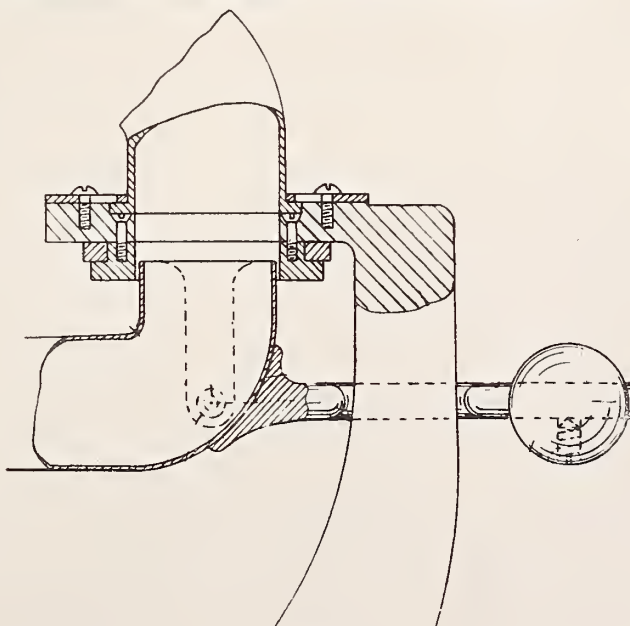

Fig. 7.

Ready to entertain propositions for Distribution and Manufacture in all countries of the World. Patents granted or pending the World over. Expect to be in New York to begin manufacture at the end of November. Send orders soon; make appointment soon. Dealings direct only; no nominees.

J. HOFFAY

P. O. Box No. 1249

New York City, U. S. A.

BEKA DOUBLE-SIDED RECORDS

BRITISH MADE THROUGHOUT

Our Latest Supplement Contains all the
PATRIOTIC AIRS and NATIONAL ANTHEMS

Catalogues and terms on application.

O. RUHL, Ltd., 77 CITY ROAD, LONDON, ENGLAND

FROM OUR LONDON HEADQUARTERS—(Continued from page 51).

nects partitioned and equipped with strong envelopes alphabetically and numerically arranged for the filing of records on scientific lines.

Prospective buyers should write for these catalogues and particulars of Edison-Bell records to Messrs. J. E. Hough, Ltd., Glengall road, Peckham, London, S. E.

"A Favorite" Postcard.

Among the recent publicity literature issued by the Utility Trading Co. is an attractive postcard which illustrates (in colors) on a small scale the firm's well-known poster showing a Greek athlete pointing to the Favorite record, all of which is suggestive of strength and presumably of meritorious quality. Dealers may have supplies upon application.

The Silver Sheath Needle.

From Messrs. Clarke I have received for personal test and review samples of his patent aluminum composite "Silver Sheath" needle, which is described as possessing unique and manifold advantages over the ordinary steel variety. One of these needles is good for an average of fifteen records without resharpening, and, this latter operation considered, it may be depended upon for the satisfactory reproduction of hundreds of records. Absence of scratch is a special feature, and with regard to tone the Silver Sheath will bring all the best out of a record at just the right volume and quality of reproduction. Its tone, in fact, is silvery to the minutest detail, and I am altogether impressed with it as a pleasing substitute for the more often than not scratchy steel needle. An outfit of six needles with a sharpener costs retail \$1.65, from which a good trade discount is offered to approved agents. Mr. Clarke will gladly send particulars upon request.

More Patriotic "Favorite" Issues.

The Favorite list of records for November contains a further batch of excellent items, mainly of a patriotic nature. Bulk record sales are of the martial flavor, few of the ordinary kind being in

COLONIAL and FOREIGN BUYERS

of gramophones and records may obtain valuable information from English firms who are desirous of opening up trading relations with oversea markets upon application, stating requirements, etc., to our European representative,

W. LIONEL STURDY

2 Gresham Buildings,
Basinghall St., London, E. C.

demand, and the Utility Trading Co. has, therefore, wisely concentrated its efforts to meeting this call by the production of new war records each month. Buyers the world over will welcome the latest numbers, for certainly they may be relied upon to make a wide appeal to all patriots. To quote a few examples of the value offered I would draw special attention to No. 747, bearing the popular war ballad, "Fall In," sung by Jack Smithson, and "A Soldier and a Man," by Henry Doyle; (749) "Our Fleet" and "Gentlemen, the King," by Stanley Wentworth; (746) "Your King and Country Want You," the famous recruiting song, and "Here's to the Day," both finely rendered by Jack Smithson; and (742) "With the British Colors" and "Bulgarian Patrol," both stirring played by the well-known instrumental organization, the Favorite Elite Orchestra. On No. 744 the popular banjoists, Olly Oakley and Joe Morley, present two pleasing duets, "Palladium March" and "Drum Major March," and among other discs of interest is No. 745, which carries "Eternal Father, Strong to Save," and "Onward, Christian Soldiers," two renowned hymns delivered sympathetically by Walter Barrett, with organ accompaniment. The Utility Trading Co., 21 Paper street, London, will be pleased to hear from all dealers open to entertain a good proposition.

Will Use the Name of Williams.

The subjoined appeared in a recent issue of the Daily Telegraph, London: "I, Victor William Opperman, a British-born subject, of No. 9 Daysbrook road, Streatham Hill, in the County of London, musical conductor, heretofore known as Victor Opperman, hereby give public notice that I have formally adopted, and determined upon all occasions whatsoever and in all deeds and writings to forthwith use the name of Williams as my last and only surname. (Signed.) Victor Williams. Witnessed by J. E. Gowing, 80, Brixton Hill, Solicitor."

Confidence in the Future.

It wants some faith in the business to go to the by no means light expense of a front half-page of the Daily Mail these troublous times. That is, perhaps needless to say, Columbia confidence, or, rather, only a commencement, since it is to be followed, we learn, by other advertising. An excellent example.

Great List of Patriotic Numbers.

Notwithstanding the extra pressure of work in connection with the supply of patriotic numbers, the British Zonophone Co. continues to issue, "as usual," new supplements each month. The latest to hand lists many excellent selections, and this important feature, considered in conjunction with a quality standard of recording unsurpassed in the record world, makes easy of understanding the great reputation and popularity of Zonophones among all nations. One could wish for no finer examples of artistic merit than is engraven upon 12-inch record A150, "Lolita," and "Nirvana," sung by Sydney Coltham, whose exquisitely sweet tenor voice is also heard to perfect advantage in "Sleep and the Roses" and "Tired Hands" on 10-inch No. 1356. A fine 12-inch, too, is that bearing "Gavotte" (Bach-Kriesler) and "Gondoliera" (Ries), played in superb style by Miss Mary Law, the well-known violinist. Other records by the famous Black Diamond Band, Alfred Cammeyer and Olly Oakley, the banjo duetists; the popular comedian, George Formby, etc., all go to suggest that the particular program under mention merits special commendation.

An "H. M. V." Patriotic Week.

"Business as usual," and quite a lot of it, is the order of the day—every day—at the Gramophone Co.'s factory at Hayes. Record making is proceeding at high pressure, and so great is the call for patriotic numbers that a special publicity scheme has been devised as a kind of celebration by which "H. M. V." agents will reap a rich harvest of extra sales. Hence the inauguration of a patriotic week, ending November 2. Now, this patriotic

The Patent Silver-Sheath Needles

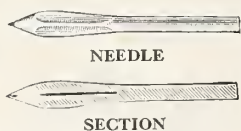

They come between steel and fibre needles and wear your records less than any metallic needle whatever. Each S/Sheath will play 400 to 500 records, with occasional resharpening.

Medium loud tone—clearest results possible—scratch almost done away with.

Prices Post Free: } 1 S/Sheath Needle...\$0.25
6 Needles with sharpener 1.65
Aluminum Sharpener, separately50

Ask for particulars of the **FLEX** loud speaking diaphragm, etc.

DAWS CLARKE, 14 Lorne Grove
FALLOWFIELD MANCHESTER, ENG.
WANTED AGENTS. Good Trade Discount.

STROH VIOLS

VIOLIN, VIOLA, ETC.

The mellow and matured tone of these instruments, which are constructed largely of aluminum, yet possess *none* of the characteristics of the gramophone or wind instrument, is only one of its many points which are fully set out in an illustrated booklet which will be mailed free on request to the sole makers.

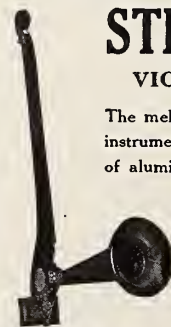

String Fiddle

GEO. EVANS & CO. 94 Albany St. London, Eng.

OR

in U. S. A. to their sole representatives

OLIVER DITSON Co.

150 Tremont Street
BOSTON

NEW YORK and PHILADELPHIA



Violin

FROM OUR LONDON HEADQUARTERS—(Continued from page 54).

week is not merely on paper; it is a real live thing planned to interest the public direct by extensive newspaper advertising in the leading organs throughout the country, and on this head alone the company has apportioned quite a liberal expenditure. Faced with such a practical symbol of confidence in the gramophone trade, the most pessimistic dealer would throw aside the shackles of doubt and get busy. He has. My last report from the "H. M. V." people is that the scheme is an amazingly fine success all along the line. Quite a large number of agents adopted the company's outline for a special window display, and altogether they seem to have entered very wholeheartedly into the spirit and letter of the plan. Congratulations.

An Important Law Action.

Freight with an unwelcome significance in its bearing upon the interests of British record manufacturers, the subjoined important law action will arouse more than ordinary attention:

Francis, Day & Hunter vs. B. Feldman & Co.—In this case the defendants appealed from a decision of Mr. Justice Neville granting an injunction restraining them from infringing the plaintiffs' copyright in the song "You Made Me Love You, I Didn't Want to Do It," in a song they had published entitled "You Didn't Want to Do It, but You Did It."

The defendants contended that there was no copyright in the plaintiffs' song, because it was published in the United States of America before being published in any part of His Majesty's dominions, to which the Copyright Act, 1911, applied. To this the plaintiffs replied that the publication took place simultaneously here and in America. Mr. Justice Neville held that there had been publication in this country within the meaning of the act and that the defendants' song was a colorable imitation of the plaintiffs' song. He therefore granted an injunction, with costs, and an inquiry as to damages. The court allowed the appeal. Lord Justice Swinfen Eady said the plaintiffs' song was a literary work within the meaning of the act, and the plaintiffs held the copyright, which gave them the sole right to produce or reproduce any essential or substantial part of the song. The same ideas ran through the defendants' song; both were on the same lines. One song recalled the other, and the defendants' song was a sequel to the plaintiffs'. But he was unable to say that unfair use had been made of the expression of ideas in the plaintiffs' song or that any substantial part of it had been taken or incorporated in the defendants' song.

Important to Business Men.

The Postmaster-General announces that the Army Council has now agreed to the use of registered addresses in extra European telegrams to and from England under the following conditions:

1. The address must have been registered before July 1 last.
2. It can only be used as the address of a telegram; its use as the signature is still prohibited.
3. Telegrams having such addresses can only

be sent to and received from British or allied territory in the extra European telegraph system (and Egypt) or the United States of America.

4. In the case of telegrams to allied territory or the United States the full name and address of the addressee must be given on the back of the telegram form.

THE WORLD'S MUSICAL INSTRUMENT

Definite Information at Last—Mr. Hoffay in New York—Manufacturing and Selling Plans Exclusive Territory for Jobbers.

Those who have closely followed my notes month by month must have read with ever-growing interest, not to say curiosity, of the gradual development of an inventor's "ideal" in connection with the science of sound reproduction. I refer in the first place to J. Hoffay and in the second to what has come to be known, especially to World readers, as "The World's Musical Instrument." American, colonial and foreign talking machine houses have evinced tremendous interest in the Hoffay patent, some evidence of which Mr. Hoffay has accumulated in the shape of hundreds of inquiries from all parts of the world. Such universal homage to a comparatively unexplained invention offers a strong confirmation of the almost general belief in the ultimate perfection of mechanical music along lines perhaps altogether different from present methods. At least, that is how one may reasonably interpret this great interest in a new invention. To crystallize sound with fidelity is recognized as presenting less difficulties in proportion to the equality of after expression or reproduction. Faithful expression of the human element—the very essence of mechanical music science, both in recording and reproduction—must carry with its attainment an influence of world-wide importance for the whole gramophone industry.

After a thorough investigation of all claims with regard to "The World's Musical Instrument" I have arrived at the conclusion that the foregoing must to some extent express my personal view of the scientific musical value of Mr. Hoffay's invention, which marks an unquestionable advance in the evolution of sound reproduction. I have been accorded the privilege of being the first press man to closely inspect a very wonderful machine—a machine in name only, since the most expert musician with the most sensitive ear would, I venture to assert, find it well nigh impossible to detect anything mechanical about it.

"The World's Musical Instrument" plays, without the necessity of detaching sound boxes or manoeuvres of that kind, all makes of discs—Edison, Victor, Columbia, Marathon, Pathe, etc.—with equal facility and perfection. The clarity and general lifelike attributes of its reproduction are really remarkable. In some circumstances the volume seems to fall a little short in comparison with the ordinary instrument, but in other instances it seems even louder, but what, in fact, happens is

that the sound being truer in pitch is really more lifelike. All of which is an advantage which makes a special appeal to those who favor a sweet tone modulated on natural sound.

The double-page announcement elsewhere in this issue gives full illustrations and particulars of Mr. Hoffay's ingeniously devised apparatus, which makes it unnecessary for me to enter upon any description of it.

Mr. Hoffay plans to be in New York some time this month, when he will make efficient arrangements for the prompt manufacture of his patents.

Finally, I would remark that "The World's Musical Instrument" offers a sure opportunity for the development of new trade fields, for even the most prejudiced—and there are a few persons who come under that category—cannot fail to succumb to its manifold charms. And that, apart from present customers, must result in an ever-increasing record trade, the very foundation and commercial life of the gramophone industry.

My sincere advice to all interested is to avoid procrastination in negotiating with Mr. Hoffay, who may be reached at New York. I understand his address is P. O. Box 1249.

FOREIGN RECORD BUSINESS

With the Columbia Graphophone Co., of New York, Shows Steady Expansion, According to Harold W. Lyle, of the Advertising and Sales Department of This Division.

The steady and consistent growth of the foreign record business is conclusively set forth in the figures submitted by Harold W. Lyle, of the advertising and sales department of the Columbia Graphophone Co.'s foreign record division. Mr. Lyle, who is a son of George W. Lyle, vice-president of the Columbia Co., is achieving a signal success in this field, due to his detailed knowledge of the requirements of this special phase of the business.

"Our sales totals for September," said Mr. Lyle, in a chat with *The World*, "show that our foreign record business for that month exceeded that of December of last year, which was the banner month of history. We tripled the foreign record business closed in September, 1913, and although I have not yet received the exact figures for October, I can safely say that we have exceeded September of this year by a substantial margin."

"The splendid growth in this division of our business must be attributed in a considerable measure to the fact that we are endeavoring to issue only those foreign records which we believe will meet with a ready sale among people who appreciate this class of music. Our monthly lists aim to cover the ground thoroughly in every foreign language that is in demand in any section of this country, and the fact that we are interesting new dealers in foreign record business day by day indicates the success of our efforts in this direction. The war abroad has acted as a stimulus to foreign record trade, according to the reports we are receiving from Columbia dealers."

FAVORITE RECORDS made in ENGLAND

Favorite Talking Machines—Favorite Needles
Favorite Albums—Favorite Carrying Cases

ARE THE CHEAPEST AND BEST

Buy Them and You Will Increase Your Profits Note Our Special Patriotic Records

Write Today for Illustrated Catalogue, Lists and Advertising Matter

THE UTILITY TRADING COMPANY, 21 Paper Street LONDON, E.C.

Cables: UTILITRACO, LONDON



The inside back cover of The Talking Machine World always carries a list of Columbia distributors down the center. It is there, in front of you, now. Get into correspondence with the nearest one.



(Write for "Music Money," a book "full of meat" for those dealers interested in quick and frequent turnover of capital.)

Columbia Graphophone Company
Woolworth Building, New York

FITTING THE RECORD TO THE CUSTOMER.

Determine the Musical Tastes of Your Patron, Mr. Dealer, Before You Attempt to Sell Him Goods—By So Doing You Will Save Both His Time and Your Own and Gain a Reputation as a Skillful Salesman—A Story That Illustrates the Point.

How many talking machine dealers, I wonder, take time, when a prospective patron walks into their establishment to purchase records, to give him the once over, as they say at police headquarters, before interrogating him as to his desires? It is safe to say that the number of talker men who avail themselves of this method of facilitating sales is most insignificant, and it is the object of this little talk of mine to show that by focusing your powers of observation upon the dress, manner and conversation of your customer, you can deal with him far more intelligently than if you neglected to enact the role of detective as well as merchant.

I can think of no business man who caters to a more cosmopolitan horde than does the chap who sells talking machines. From Professor Strauss, of the university on the hill, to Cyrus Simkins, from Hickory Corners, N. J., they come to him for records and, would you believe it, I have witnessed a young man who considered himself the very latest thing in clerkship place upon the turntable, "Down Home Rag" for the professor, while Cyrus was treated to a rendition of "Andante from deBeriot's Seventh Concerto."

"Ach himmel! I vant moosic, not noise," wailed the outraged professor.

"Say, young feller, when is that there fiddler goin' to stop tunin' up? I'd like mighty well to hear him play somethin'," drawled Cy, disgustedly, etc., etc. Do you get me?

It is most necessary in order that a talking machine dealer may get in close touch with the phonographic desires of his patrons that he use every means in his power to scrutinize them scientifically. My friend, John Jones, talking machine merchant de luxe, keeps track of the musical tastes of every customer who calls upon him by a simple method of bookkeeping. These books, which bear the title, "My Customers," are of the greatest possible assistance in selling goods because they show the kind of record that will appeal to a certain type of individual. For instance, when Cyrus Simkins calls upon John Jones, the clerk recognizes at a glance the rural land owner. Glancing through "My Customers" he eventually

reaches the page devoted to primitive agriculturists and discovers that selections like "Silver Threads Among the Gold," "The Old Oaken Bucket," "Annie Laurie," with an occasional coon song, and perhaps a rag or two, will strike Cyrus about right. He, forthwith, proceeds to do a nice little business with the gentleman from Hickory Corners without the loss of time that would naturally accrue through not knowing just what record to play. If every talking machine dealer would follow in the footsteps of Jones regarding this matter they would find that there would be more sales made and fewer dissatisfied customers.

It is a difficult proposition to demonstrate a



The Process of Demonstration.

talker outfit to a person who is not at all familiar with it. Especially is this true of a musician who is prejudiced against canned melody in any form. However, if you are able to judge from the personality of your caller, the kind of selection that will most appeal to his artistic sense, half the battle is won at the outset.

Fortunately for the dealer, the talking machine has reached such a state of perfection that even a musical critic cannot conscientiously condemn it. Therefore the time has come when it is not a case of one record being superior to another in so far as mechanical imperfections are concerned, as it was in the early days of the talker, but when one selection will lead another only through the ability of the artist and the composer. In other words, the talking machine has arrived. It has joined the ranks of the makers of true melody, and is fast pressing onward to its rightful place at the head of them all. The day is not far distant, believe me, when every instrument, even the imperfect piano, will be mastered phonographically, and when that time comes the talking machine will stand supreme, its competitors in precipitous retreat. So you see, Mr. Dealer, you are not selling mechanical toys any more. Neither are your records noisy and gritty reproductions of real music.

This means a very great deal, for it does away entirely with the need of playing records in private prior to their public rendition. I can remember when my friend, John Jones, used to test every record before placing it on sale, and that was not so very many years ago either. He was forced to adopt this method for his own protection against the harsh criticisms of his customers. When the blasts and knocks developed in cylinders or discs that had not received an elimination test, Jones wished most devoutly that some other business than that of dispensing talkers had claimed him for her own. However, that is past and gone now, and Jones is happy. He has every reason to be contented to-day, for he has specialized his profession to the extent of placing his talker shop in an advanced state of prosperity through many clever and unusual methods of business building, some of which have already been outlined in The World. I am sure, Mr. Dealer, if you adopt the trade boosting stunt suggested above you will find it a most worthy one.

From now on each time Mr. A. Prospective Customer enters your store greet him effusively; be the hospitable host to the degree of making him loquacious. You know, do you not, that there is no better way to bring to the surface a fellow's habits, ambitions, and, above all, his likes and dislikes, than by urging him to talk. Well, inasmuch as we have steered this particular conversation into phonographic channels, and you have established yourself as an interested listener, it will not be a great while before the subject of records will be broached. Then it naturally follows that the selections he likes best will come forward. Result: A concert made up exclusively of the very cream of your stock, so far as Mr. A. P. C.'s tastes are concerned, which, of course, means a quick sale and a satisfied patron. What more, pray, can a dealer ask?

Jones lives in a town which has some fame as a resort, and is visited throughout the season by a great many people from not only other states, but other countries as well. He makes a point of appealing to the patriotism of these folks by first ascertaining from whence they come, and then entertaining them with a concert made up of records containing a certain amount of local color. To illustrate: To the chap who hails from the state with its golden gate ajar, he renders "I Love You, California." The fellow from Baltimore is made happy by the strains of "Maryland, My Maryland." The retired rancher from San Antonio reaches for his silken bandanna when Edgar L. Davenport, in his pathetic recitation, "Lasca," explains that "scratches don't count in Texas, down by the Rio Grande." The Yankee is touched with the pathos of "My Old New Hampshire Home," while even the man from the state of mosquitoes and Presidents appreciates "Over on the Jersey Side."

When Jones explained this treatment of transients to me, I asked him a question. "John," said I, "will you tell me, please, why this sort of thing pays? I can understand, all right, why a record suggesting one's own state or town would play upon the heart-strings and force a fellow to loosen up to the extent of purchasing that particular

Statement of the ownership, management, etc., of The Talking Machine World, published Monthly at New York, required by the Act of August 24, 1912.

Name of	Post-Office Address
Editor, EDWARD LYMAN BILL	373 4th Ave., N. Y.
Managing Editor, J. B. SPILLANE	373 4th Ave., N. Y.
Business Manager, AUGUST J. TIMPE	373 4th Ave., N. Y.
Publisher, EDWARD LYMAN BILL	373 4th Ave., N. Y.
Sole Owner, EDWARD LYMAN BILL	373 4th Ave., N. Y.

There are no bondholders, mortgagees or other security holders. (Signed) Aug. J. Timpe, Bus. Mgr.
Sworn to and subscribed before me this 22d day of [SEAL] September, 1914.

Eugene R. Falck, Notary Public 4
(My commission expires March 30, 1916.)

selection. So far, so good, but does it pay to go to all that trouble of identification, etc., for one record?"

"My boy," remarked Jones pityingly, "you should know better than to ask a question so foolish. You have actually mingled among the talker fraternity for ten long years and have yet to learn that to sell a big bill of goods to a man, particularly when he's homesick, you must play something for him right at the start that will set him going—'play upon the heart-strings,' as you express it. Bah! I'm ashamed of you."

I have been giving the manufacturers a few hints lately, as you may have noticed if you have been kind enough to read my stories. Taking it for granted that there is always room for one more, I submit the following: You have seen, of course, the tide of patriotism that is sweeping over our country because of the war in Europe. You know what a stir has been caused by the "Made in America" advertisements of our great department stores. Everywhere you gaze upon the shield and the flag. As I write the Philadelphia Evening Bulletin lies open upon my desk. On page five there is a full page spread containing the following patriotic adornments: One coat of arms of Philadelphia, twenty sketches of Old Glory and the celebrated poem, "America," accompanied by an artistic drawing in pen and ink showing the liberty bell and draped flags.

LANDAY WHOLESALE GROWTH.

Most Marked During the Past Month—Compliments for the Talking Machine World as an Effective Advertising Medium.

"The growth of our wholesale business is a matter of considerable pleasure," said Max Landay, of Landay Bros., 563 Fifth avenue, New York, Victor distributors. "Orders are being received regularly from our patrons, and we are extending co-operation to our trade by giving them prompt service in every meaning of the word. I may say in this connection that the use of the advertising columns of The Talking Machine World has been an im-

portant factor in the extension of our wholesale business. Our announcements have evidently been read by Victor dealers in all parts of the country, and the results from this advertising have pleased us greatly."

TO MAKE TALKING MACHINES.

Eaco Films is the title of a new concern which has been incorporated with a capital stock of \$5,000 under the laws of New York for the purpose of engaging in the manufacture of motion pictures, talking machines, etc. The incorporators are Edwin August, E. E. Anderson and M. C. Goldman, all of New York City.

COUNTRIES BUYING OUR GOODS.

Some Interesting Particulars Regarding the Exports of Talking Machines and Records as Set Forth by a Writer in Printers' Ink.

In an interesting article headed "What Countries Have Bought Our Goods?" Printers' Ink of recent date gives an informative discussion of the progress that American manufacturers in various lines have achieved in blazing the trail of commercial activity throughout the world.

Referring to the talking machine industry in this connection, this article reads as follows:

"American manufacturers of talking machines and phonographs and records for such instruments have attained within a few years a most excellent distribution—that is, widespread and evenly balanced distribution for their goods—in the foreign field. What these firms have done should, moreover, be something of an inspiration to others because they found it necessary to, in a sense, do double work to win the foreign market. The average manufacturer may cater successfully to oversea trade by merely making slight changes in his product, say by altering his standard models to conform to national preferences.

"In the case of the 'talker' trade, however, it was not a simple selling proposition. Before it reached that stage the companies had to send out expensive expeditions to various quarters of the globe in order to secure vocal and instrumental records by the best musical celebrities. In consequence of this thorough-going policy and in the face of keen British, French and German competition, the American graphophone and phonograph companies sold in Canada, during the twelve months ending on the first day of last July, goods to the value of nearly \$900,000—a gain in sales of nearly 100 per cent. in two years. In Australia the sales jumped in this one year from \$82,000 to \$182,000. In South America the sales for the period footed \$350,000, and would have been easily twice as much but for the money stringency which has hit Latin America during the past year."

JOBBER CONNECT WITH PROFIT

FLEXIBLE

BY HANDLING

FLEXIBLE

The Flexible Four Pointed Steel Needle

PATENTED IN U. S.—FOREIGN PATENTS PENDING

Flexible Needles are guaranteed to play the Longest Records Perfectly.

Flexible Needles are guaranteed to save the record from wear.

Flexible Needles are guaranteed to eliminate the scratch.

Flexible Needles make old records sound like new.

Four Pointed Flexible Needle

FLEXIBLE

PATENTED
FOUR TUNES ON ONE NEEDLE

Flexible Needles are better because they do more.

Flexible Needles are made from the best steel obtainable.

Flexible Needles are the best for any record because they bring out all that is in the record.

In Attractive Packages of 200 Points.

Increase Your Profit.

Send for Samples and Prices today.

Two Sources of Supply.

FLEXIBLE

FLEXIBLE

JOHN M. DEAN, Inc.
PUTNAM, CONN.

Write to
the Nearer

SAMUEL LEVIN
HIGHLAND PARK, ILL.

STOP! READ! ACT!

Are you interested in an attractive business proposition?

We say attractive—yes, exceptionally attractive.

We rank among the largest producers of pianos and player-pianos in the world.

There are a good many piano prospects which enter your store, Mr. Talking Machine Dealer—a good many. Why let them get by you into a regular music store?

We can tell you how to stop them and at the same time stop the dollars which get away from you when the trade leaves your store.

We have an ideal proposition for the talking machine dealer.

Take it up with us, will you? It will only require a small part of your store and practically little or no trouble.

H. P. NELSON COMPANY
816 No. Kedzie Avenue, Chicago, Ill.

TRADE NEWS FROM INDIANAPOLIS.

Prominent Piano Houses Take on the Edison Disc Phonograph Line—Stewart Co.'s Big Victor Trade—Columbia Co.'s Artistic Window—Month's News of Interest.

(Special to The Talking Machine World.)

INDIANAPOLIS, IND., November 11.—Announcement is made by the Kipp-Link Phonograph Co., 345 Massachusetts avenue, Edison distributors, of the handling of the Edison diamond disc talking machines by the Pearson Piano House, 128-130 North Pennsylvania street; the Carlin Music Co., 33 North Pennsylvania street, and the E. L. Lennox Piano Co., 311 North Pennsylvania street.

The E. L. Lennox Piano Co. has had the Edison line for several months, and is enlarging its talking machine department. Pearson's and Carlin's have just put in the Edison talking machines. Pearson's, Carlin's and Lennox's are conducting extensive Edison advertising campaigns in the daily papers.

Walter E. Kipp, president and manager of the Kipp-Link Phonograph Co., is very optimistic in regard to the business prospects for the early winter. Notwithstanding the general depression in business, Mr. Kipp says his company is busy every minute in meeting the demands of the trade. The display rooms of the company have been redecorated.

W. S. Barringer, manager of the Stewart Talking Machine Co., distributors for the Victor line of talking machines and records, says the company enjoyed the best September and October business in the history of the house. Larger shipments throughout the State to victrola dealers were made in October than ever before, Mr. Barringer said. The Stewart Co. has employed additional men to take care of the increased business in the wholesale stock rooms. The Stewart Co., since it was started several years ago, has experienced a phenomenal growth. It has been necessary for the company to enlarge its quarters to accommodate the increased business of the house.

A. W. Roos, manager of the Columbia Graphophone Co.'s store at 27 North Pennsylvania street, is very much pleased with the results of October in his territory. Business is good, the month showing a marked increase over last month as well as against October of 1913, Mr. Roos says. Mr. Roos sees no depression in his field because of the European war or anything else.

The store of the Columbia Graphophone Co., at Terre Haute, Ind., has been placed under the supervision of Mr. Roos. Sales there the first month of the new arrangement were very gratifying. Mr. Roos looks forward to a big season for both stores, and there is every indication that his hopes will be realized. Collections on outstanding accounts, he announces, are above normal.

H. M. Wright, floor manager at the Indianapolis branch of the Columbia Co., once more has gone into the forest and field to make an attractive window in keeping with the season of the year. As a result the Columbia window is an exact reproduction of a cornfield, showing standing corn, shocked corn, and the stubbles of the stalks. A prolific pumpkin vine is shown winding in and out among the corn stalks, with seven or eight inviting pumpkins "growing" right in the window. Needless to add, the window contains enough Columbia products and descriptive literature to make the display a real Columbia advertisement.

H. J. Weir, formerly with the Kipp-Link Phonograph Co., is now with the E. L. Lennox Piano Co., as head of the phonograph department.

The Fuller-Wagner Music Co., which took over the assets of the Wagner Music Co., has put in the Victor line of talking machines. The Pearson Piano Co. has been featuring in its advertising the offer to join one of its Christmas Victrola clubs, the plan being to make payments now and obtain a Victor machine at Christmas time.

RATTLING THE DOORS TO SUCCESS.

Some men stand all their lives vainly rattling the doors to success and wondering where those inside got their keys.



NYOIL

For polishing varnished woodwork it is extremely satisfactory. No oil is so clean.

Ask your watch repairer whose oil he uses on your watch.

HOLDS DANCING EXHIBITION.

Loomis Temple of Music Features Victor Dance Records in Elaborate and Effective Manner in New Haven, Conn.

(Special to The Talking Machine World.)

NEW HAVEN, CONN., November 7.—The Loomis Temple of Music attracted much attention to its store and business last week by holding an elaborate free exhibition of modern dances on Wednesday evening, at which a pair of professional dancers appeared and where the Victrola supplied all the dance music.

Several hundred people, a capacity audience, gathered at the Loomis Temple of Music in response to special invitations sent out by the house and witnessed demonstrations of a half dozen of the latest society dances, including the fox trot and the Lulu fado. On the program supplied there appeared in connection with the name of the dance the number of the Victor record used and the title of the selection, while between dances November Victor records were demonstrated. The exhibition was carried out in a first class manner and the audience was a representative one, most of the members of which were known to own talking machines or were excellent prospects. Much interest was displayed in the records used and a large number of them were sold immediately after the closing of the exhibition.

PATTEN WITH NEWBRO DRUG CO.

Takes Charge of Columbia Department—W. S. Storms Chats of Business in Des Moines.

(Special to The Talking Machine World.)

SPokane, WASH., November 5.—J. R. Patten, who has been traveling representative for the Columbia Graphophone Co., of this city, covering Washington, Idaho and Montana, has just accepted the management of the talking machine department of the Newbro Drug Co., of Butte, Mont. Mr. Patten states that he is very optimistic over the outlook and expects to do a humming talking machine business during this fall and through the holidays.

The Newbro Drug Co. is the largest drug company in Montana, and has one floor entirely devoted to Columbia Grafonolas. It handles a complete line of Columbia goods, and does a great deal of advertising throughout the State of Montana of its product.

In discussing the business situation, Willis S. Storms, local manager, said: "The war seems to have had no effect on our business here; on the contrary, we have made a healthy increase over last year and anticipate that our holiday business will be the biggest in our history. We are having a very large demand for the new Columbia Leader Grafonola with the individual record ejector. The dance business is going big here."



Looking back one year at the Columbia progress ought to make it easy for you to look ahead one year and make a pretty shrewd guess.



(Write for "Music Money," a book "full of meat" for those dealers interested in quick and frequent turnover of capital.)

**Columbia Graphophone Company
Woolworth Building, New York**

EDISON DEALERS IN EVIDENCE

At Harvest Homes and Country Fairs Held in Various Parts of the Country Recently.

Edison disc and cylinder products have been prominent factors in the various harvest homes and county fairs held in different parts of the country the past few months. In many instances floats and exhibits devoted to the Edison phonographs have received first prize, and, needless to say, Edison dealers exhibiting the line have taken full advantage of the publicity offered them through this medium.

In Aurora, Neb., C. E. Nair, a live-wire Edison dealer, designed a float for the Harvest Festival in that city, which was awarded the first prize. This float featured Edison diamond disc products exclusively, and a \$200 machine was operated invisibly. The selections chosen were such as to arouse much favorable comment, and the phonograph was kept playing throughout the entire parade.

John R. Bolz, Edison dealer at Kiel, Wis., constructed an attractive Edison float for the "Home-Coming Harvest Week" in that city, which was among the best floats shown, and enjoyed appreciation from thousands of visitors.

One of the most attractive events that the bustling city of Hanover, Pa., has ever introduced was the recent county fair, which drew great crowds from all sections of the surrounding territory. Ivan White, enterprising and live-wire Edison representative in that city proved himself equal to the occasion, and designed an Edison float which was distinctive and artistic to a degree.

The Monmouth County Fair is always one of the most important events staged in Southern New Jersey, and this year's fair was a banner one. The Tusting Piano Co.'s booth was voted one of the finest at the fair, and the Edison \$250 disc phonograph featured at the booth was awarded the blue ribbon for the highest type of musical instrument exhibited. F. A. Richie, of the Phonograph Corporation of Manhattan, Edison jobber, was in charge of the exhibit.

Another splendid Edison display was that of the Coocy-Bentz Co., at the West Virginia fair field, at Wheeling, W. Va., held recently. The Coocy-Bentz Co. used for this occasion two Edison \$250 disc models, one to attract the crowds by continual playing, and the other for demonstration. One result of their exhibit at the fair was the securing of an excellent list of prospects who evinced keen interest in the Edison disc products.

H. C. BROWN'S NIMRODIAN EXPLOITS.

H. C. Brown, advertising manager of the Victor Talking Machine Co., Camden, N. J., was a visitor to New York recently in regard to the erection of a new building in which the Sphinx Club is interested, and of which he is president. Mr. Brown, by the way, has just returned from a hunting trip to New Brunswick, Canada. He "brought down" a few moose and other game during his Nimrodian peregrinations.

Habits are like appendices. When they begin to hurt it's time they were "cut out."

A YEAR OF EXPANDING BUSINESS.

The Dallas Phonograph Co. Was a Year Old on November 1—Enjoys Large Edison Trade.

(Special to The Talking Machine World.)

DALLAS, TEX., November 1.—To-day the Dallas Phonograph Co., of this city, celebrates the conclusion of its first business year, having opened up on November 1, 1913, handling the Edison diamond disc and Columbia Grafonola. The initial force consisted of three employes, which during the year has increased to ten or more, thus demonstrating the development of this business under the able management of S. T. Brannan, vice-president and manager.

The warerooms at 909 Elm street are attractively arranged, with a number of handsome sound-proof parlors for the convenience of buyers. The manager reports an increasing business in the Edison disc line. An excellent trade is also being done with the Edison dictating machine, this company being the distributor for northern Texas.

TRADE NEWS FROM PITTSBURGH.

Lechner & Schoenberger Co. Handle "Talkers" —Schoen Co.'s New Quarters—Kaufmann's Victrola Concerts.

(Special to The Talking Machine World.)

PITTSBURGH, PA., November 10.—The Lechner & Schoenberger Piano Co., 631 Liberty avenue, has completed the installation of its talking machine department, which is one of the most attractive and up-to-date in the city. The four booths are constructed along lines that make for the greatest convenience and also complete comfort for patrons, as their features embrace a very unique and effective ventilating system. D. S. Hartley, formerly of the S. Hamilton Piano Co.'s talking machine department and a man of long experience in this line, on November 1 assumed the management of the new department. Mr. Hartley is very optimistic concerning the outlook for holiday trade and, with his two splendid lines, the Edison and the Columbia, he expects to get his share of the business transacted during this and next month.

H. N. Rudderow, manager of the Kaufmann Bros. Victrola department, reports that October's business was nearly 50 per cent. above the previous month and also October of 1913. He is planning a series of Victrola concerts to be held soon in the Big Store's auditorium.

The Schoen Music Co., which has moved its establishment from 119 Federal street, Northside, to 620 Penn avenue, is preparing to push more strongly its talking machine department, which was installed about five months ago. The Columbia instruments are being handled.

HOLIDAY ADVERTISING IN ORDER.

Some Very Effective Publicity Issued by the Victor Co. as an Aid to Dealers to Stimulate Holiday Trade in Machines and Records.

The Victor Talking Machine Co.'s newspaper advertisements for the month of November will be based principally on the desirability of selecting a Victrola for Christmas and the success of the Victrola as an instrument for furnishing dance music. The Victrola XVI, at \$200, is featured in three of these advertisements, and Mr. and Mrs. Vernon Castle dancing the fox trot in the other two advertisements. Particular attention will be called to the fact that Mr. and Mrs. Castle use the Victor exclusively and superintend the making of Victor dance records.

Accompanying its advance copy of new Victor records for December, which go on sale November 28, the Victor Co. has sent its dealers a proof of a new and unusually attractive Christmas car-card lithographed in brilliant Christmas colors—red, green and gold—which will be furnished the dealers free of charge, imprinted with their name and address, provided they have a contract with the street car company for twenty-five or more cards.

INCORPORATED.

His Master's Voice, Ltd., Toronto, Ont., has been incorporated with capital stock of \$100,000 to manufacture talking machines, etc. The incorporators are J. S. Lovell, William Bain, Robert Gowans and others.

Victor Distributors

Ten years of exclusive Victor Jobbing in
Maine and New Hampshire

Service Our Success

CRESSEY & ALLEN
Portland, Maine

LATEST PATENTS RELATING TO TALKING MACHINES AND RECORDS

(Special to The Talking Machine World.)

WASHINGTON, D. C., November 10.—CABINET FOR SOUND REPRODUCING MACHINES.—Helge A. Bortsen, Marquette, Mich. Patent No. 1,109,386.

This invention has relation to improvements in cabinets for sound reproducing machines, and has for its special objects, first, the provision of such a cabinet in such form that it may be embodied in a desk, cabinet table or other like piece of furniture; second, the provision in such a cabinet of an arrangement which will permit the amplifying or delivery horn to extend directly without turn or bend at right angles from the sound head and vibrating membrane; third, the provision in such a cabinet of simple means for assisting the feeding

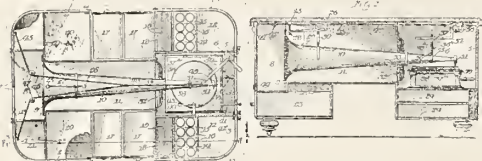

of the stylus over the record, and fourth, the provision of simple means for operating my cabinet

To effectuate the above objects there is provided the mechanism illustrated in the accompanying drawings, in which Fig. 1 is a plan, partially in section, of a cabinet table embodying the invention, taken on the line X—X of Fig. 2; Fig. 2 is a cen-

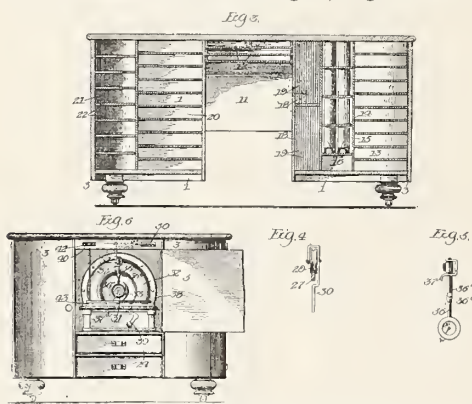

tral, longitudinal elevation of the invention partially in section; Fig. 3 is a longitudinal sectional elevation taken on line Y—Y of Fig. 1; Fig. 4 is a detail of the adjustable inclined horn-suspending feeding rail; Fig. 5 is a detail of the sound head guide rail, and Fig. 6 is an end elevation of the cabinet table showing the doors to the phonograph compartment open.

SOUND-BOX FOR TALKING MACHINES.—Horace Sheble, Philadelphia, Pa. Patent No. 1,102,090.

The object of this invention is to so construct a sound box for talking machines as to provide for the use of the same either in connection with a record having a "lateral wave" groove or with a record having a "hill-and-valley" groove, such dif-

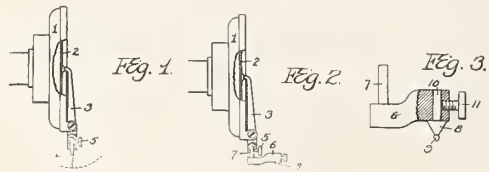

ferent records being employed without the necessity of changing the angular relation thereto of the sound box diaphragm.

Fig. 1 is a view, partly in side elevation and partly in section, of an ordinary talking machine sound box illustrating the same as designed for use with a record of the lateral wave type; Fig. 2 is a similar view illustrating the sound box as adapted for use in connection with a record of the hill-and-valley type, and Fig. 3 is an enlarged view of the converting attachment shown in Fig. 2.

SOUND-BOX.—Jonas W. Aylsworth, East Orange, N. J., assignor by mesne assignments to New Jersey Patent Co., West Orange, N. J. Patent No. 1,115,374.

This invention relates to sound boxes particularly of the type adapted for use in connection with disc records having vertically undulating grooves, although its use is not limited to that type.

With reproducers commonly in use, the tracking of the record groove by the stylus causes the emission of minute scratch vibrations which greatly impair the quality of the reproduction. It has also been found that when the stylus is rigidly connected with the diaphragm excessive loudness is given to some of the vibrations.

It is the principal object of the invention to provide a sound box free from these objections; and in conformity with this object, there is provided a composite stylus arm having interposed between the sections thereof an elastic yielding substance which will absorb the minute scratch vibrations and which will at the same time retard or dampen the excessively loud vibrations.

Another object of the invention is to provide adjusting means whereby the loudness of the

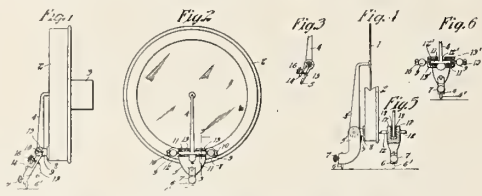

record may be modified and variations in the set of the diaphragm compensated for.

Fig. 1 represents a side elevation of a sound box embodying the invention; Fig. 2 represents a front elevation thereof, the connection between the two sections of the stylus arm being shown in central longitudinal section; Fig. 3 represents a fragmentary sectional view taken on the line 3—3 of Fig. 2; Fig. 4 represents a fragmentary side elevation partly in section of a modification; Fig. 5 represents a front elevation partly in section of the stylus arm shown in Fig. 4, and Fig. 6 represents a similar view of still another form of stylus arm.

DISC SOUND RECORD.—Victor H. Emerson, New York, assignor to American Graphophone Co., Bridgeport, Conn. Patent No. 1,113,973.

This invention relates to the building up of a suitable tablet or disc that is to constitute the

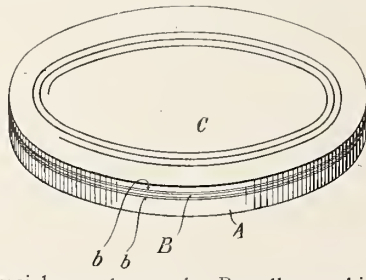

commercial sound record. Broadly speaking this tablet consists of a main portion or body, a facing that contains the irregularities corresponding to the sound waves, and an intermediate layer or stratum that serves the two-fold purpose of securing the facing of the main portion and of otherwise contributing (in a manner to be explained) to the production of the commercial sound record.

In the drawing annexed hereto to illustrate an embodiment of the invention, the parts are shown greatly exaggerated in thickness.

METAL SOUND RECORD.—Thomas H. Macdonald, Bridgeport, Conn. (deceased), assignor to the American Graphophone Co., same place. Patent No. 1,114,010.

The object of this invention is to produce a sound record of greatly improved durability without any sacrifice of quality.

It is well known that with the sound records now on the market each reproduction causes deterioration, and that after several hundred reproductions or sometimes even less, the record becomes so poor as to be practically worthless. It has long been desired to obtain for permanent preservation records of celebrated personages, great

singers, etc. Such records can be preserved for a long time, perhaps indefinitely; but each use thereof, for audible reproduction, to that extent tends to destroy them. By this invention is produced a permanent sound record which can be used thousands of times without any appreciable deterioration, and which can be preserved for indefinite ages, yet without any sacrifice of quality.

This invention will be best understood by reference to the annexed drawings that illustrate preferred methods of procedure, the discs shown in the drawings being somewhat exaggerated in thickness for sake of clearness and the drawings themselves not being made to scale, but merely as illustrations.

In the drawings Fig. 1 is an elevation intended to represent conventionally the production of an "original" disc sound record of the vertically undulating type, and Fig. 1a is a similar view repre-

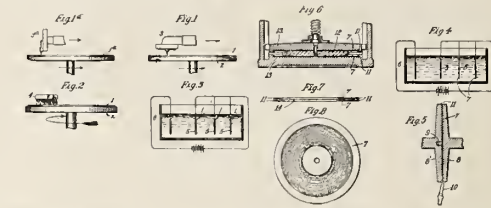

sending the production of an "original" disc sound record of the laterally-undulating type; Fig. 2 is an elevation indicating the operation of rendering the surface of such "original" electro-conductive; Fig. 3 is a transverse vertical section through a conventional representation of an electroplating bath for producing the electroplate masters or "negatives" of the "originals," and Fig. 4 is a similar view representing the production from such negatives of electroplate "positives;" Fig. 5 is a sectional view of a pair of rotating chucks, indicating the turning back of the circular edge or rim of such metal "positives;" Fig. 6 is a vertical section through a press, representing the pressing-up of the double-faced sound record; Fig. 7 is an edge view, and Fig. 8 a face view, representing the completed record.

PHONOGRAPH ATTACHMENT.—Albert H. Leissing, New York. Patent No. 1,114,492.

The general object of the invention is to effect the removal of particles of dust, dirt or the like, from the grooves or indentations of the surface of a sound record. And to this end the invention resides in providing a cleaner in the form of a brush and in adapting the brush to connect with any desirable portion of the phonograph, such as the diaphragm casing, and in adapting the connecting part of the brush to hold the brush in contact with the surface of the sound record when the said connecting part is attached to the phonograph.

Fig. 1 is a perspective view of a portion of a phonograph showing the improved device connected

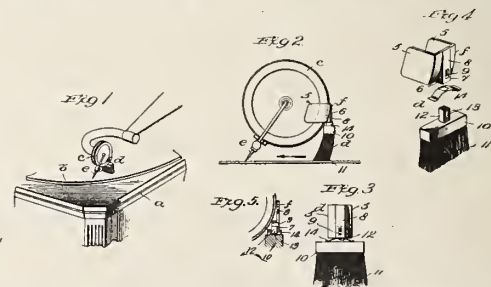

to the diaphragm casing. Fig. 2 is an enlarged detail side elevational view of the diaphragm casing and showing the improved device connected thereto. Fig. 3 is a rear elevational view of the improved device. Fig. 4 is a detail perspective view of the device showing the parts separated. Fig. 5 is a detailed sectional view of the connection between the brush handle and the pocket.

STYLUS.—Samuel Levin, Highland Park, Ill. Patent No. 1,114,493.

The present invention relates to an improved stylus, especially adapted to be used in connection with disc sound reproducing machines, one object of the invention being the provision of a stylus, which being made of resilient material, which is rectangular in cross section, will not unduly scratch the sound grooves of the record and which will be provided with a plurality of groove engaging points, so that the life of the stylus will be greatly in-

LATEST PATENTS RELATING TO TALKING MACHINES—(Continued from page 60).

creased, as will also the endurance of the record.

A further object of the invention is the provision of a flat resilient stylus, which may be composed of any material, either metal, fiber, wood, celluloid or in fact any material that will answer the purpose, the opposite ends of the same being provided either with a plurality of groove-engaging points or a single groove-engaging point, so that the same may be readily attached to the usual form of reproducer used in connection with disc sound reproducing machines, the same being disposed at an angle to the sound groove, and the rotation thereof, so as to resiliently support the sound reproducer and thus reduce the wear upon the record, such stylus when having more than one point upon each end, being disposed at such angle, that only one point is in engagement with the sound record groove, while the other point is elevated thereabove.

In the drawings Fig. 1 is a plan view of one form of stylus made according to and embodying the present invention. Figs. 2, 3 and 4 are plan views of modified forms of stylus embodying the present invention. Fig. 5 is a diagrammatic view

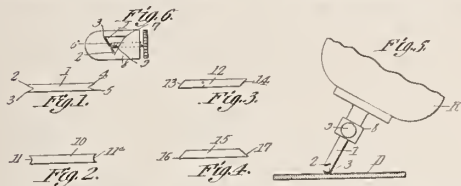

of a reproducer, and a portion of a disc record with the stylus as shown in Fig. 1 in operable relation thereto. Fig. 6 is a bottom plan view of the stylus receiving member of the reproducer showing the position the stylus is held in when clamped thereto.

PHONOGRAPHIC SOUND BOX.—John H. Van Mater, Atlantic Highlands, N. J. Patent No. 1,111,779.

This invention relates to means employed for transmitting articulate and musical sound vibrations from the contact needle of a phonograph to a resonant diaphragm, and from which they are transmitted in the form of sound waves by a suitable amplifier.

The object of this invention is to produce and preserve the vibrations peculiar to articulate speech and musical sounds, to the exclusion of those produced by the scratching or frictional effects peculiar to phonographs.

In phonographs, heretofore part of their sound vibrations have been transmitted from the stylus point to the interior of the amplifying horn through mechanical connections or sound conductors leading from the stylus needle to the material forming the sound box, thence through such material to the interior of the horn; and such sounds so transmitted irrespective of a diaphragm or sounding board are generally of an objectionable nature.

In carrying out this invention and to avoid such objectionable sounds, all parts of the mechanism employed for recording and reproducing musical and articulate sound vibrations, including the stylus and its holder, are insulated from the sound box and horn, by means of a keeper composed of material which offers an effective resistance to the passage

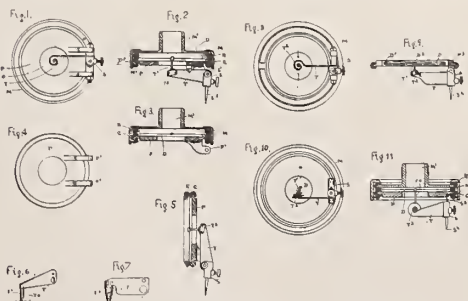

of all sound vibrations through it; so that the only way that such vibrations can be transmitted from the stylus to the interior of the horn must be through a single transmitting member leading from the needle to a diaphragm and thence to the interior of the horn.

This invention further embraces certain forms of a sound transmitting member leading from a

stylus to a resonant diaphragm and adapted for carrying with an increasing volume and clearness certain vibrations common to musical sounds and articulate speech which accord with certain vibratory characteristics of said member, and in transmitting with a decreasing force and clearness other sound vibrations which do not accord with the same.

Fig. 1 is a plan of the under face of a phonograph sound box embodying the invention; Fig. 2 is a sectional elevation of the device shown by Fig. 1; Fig. 3 shows a part of the device of Fig. 2, in section; Fig. 4 is a plan of the under face of a part of the device of Fig. 1; Fig. 5 is a modified form of the device of Fig. 2, shown in section; Figs. 6 and 7 are modified forms of part of the device of Fig. 1; Figs. 8 and 9 show a working form of the invention, and Figs. 10 and 11 show a practical form of mechanism.

PHONOGRAPH RECORD.—Thomas A. Edison, West Orange, N. J., assignor to the New Jersey Patent Co., same place. Patent No. 1,111,999.

This invention relates to phonograph records having a surface of wear-resisting material, such as celluloid.

The object of the invention is to provide a record of this type permitting the reproduction of the sound record formed thereon with distinctness, loudness and purity. It has been common to provide records with surface films or veneers of hard materials such as celluloid; but the reproduction from these records has usually been accompanied by harsh, unpleasant scratchy sounds which have been discovered to be due to the fact that the record surface is hard and unyielding so that the reproducer strikes the bottom of the record groove with a more or less sharp blow. In order to overcome this and other objections and at the same time provide a wear-resisting surface for the record, the inventor has constructed an improved record of a flexible or yielding surface film or veneer of hard material, such as a thin sheet of celluloid, and provide a resilient or yielding backing therefore, this backing being in the preferred construction formed of a base of hard material, such as plaster of Paris, and a thin film or layer of resilient material such as rubber, intermediate said surface veneer and base. The resilient material should be a substance such, for example, as rubber, which yields but is not liable to permanent deformation under the pressure of the reproducer stylus. The resiliency of the intermediate film or layer permits a slight flexing or yielding of the surface film or veneer under the reproducer so that the sharp blows of the reproducer are cushioned and the harsh noises above referred to eliminated; while the rigidity of the base prevents a diminution of the amplitude of the sound waves as reproduced, so that the sound waves on the record surface are transmitted with full amplitude to the reproducer diaphragm. It is understood that the intermediate film above referred to yields only sufficiently to permit the cushioning of the stylus so as to eliminate the harsh sounds referred to above.

Fig. 1 represents a central vertical sectional view of a cylindrical sound record embodying this invention; and Fig. 2 represents a similar view of a disc sound record embodying the invention.

STYLUS GUIDING ATTACHMENT FOR SOUND RECORDS.—Chas. W. Ebeling, Wheeling, W. Va., assignor of one-half to Harrison W. Rogers, same place. Patent No. 1,112,407.

The present invention relates to improvements in stylus guiding attachments for sound records, the present application being a divisional application of co-pending application filed May 20, 1913, Serial No. 7,668,845, one object of this invention being the

provision of co-operable means, carried by the reproducer and the sound record, whereby the stylus is held above the record during a portion of the revolution thereof and finally delivered into the phonic groove thereof at the proper point.

In the drawings Fig. 1 is a plan view of a disc record with the present attachment applied thereto. Fig. 2 is a side view of a record and reproducer with the present attachment in use in guiding and retaining the stylus from contact with the record. Fig. 3 is a view taken from the right as illustrated in Fig. 2.

STYLUS GUIDING ATTACHMENT FOR SOUND RECORDS.—Chas. W. Ebeling, Wheeling, W. Va., assignor of one-half to Harrison W. Rogers, same place. Patent No. 1,112,406.

The present invention relates to improvements in stylus guiding attachments for sound records,

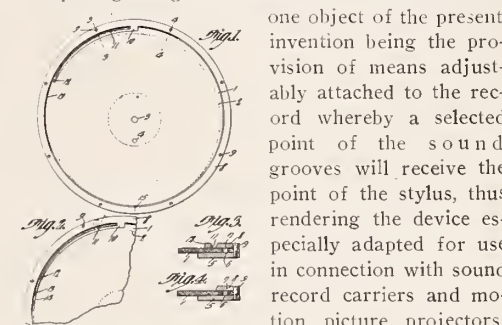

one object of the present invention being the provision of means adjustably attached to the record whereby a selected point of the sound grooves will receive the point of the stylus, thus rendering the device especially adapted for use in connection with sound record carriers and motion picture projectors, and particularly with the structure as set forth in co-pending applications of Harrison W. Rogers filed February 7, 1913, Serial Nos. 746,890 and 746,891.

A further object of the present invention is the provision of means which may be properly attached to the periphery of a disc sound record, and which is particularly designed for use upon any of such records, and in which the stylus guiding and starting portion thereof may be properly adjusted longitudinally and transversely of the record, so that the stylus after once positioned will be directed to the desired selected point of the sound groove thus rendering it unnecessary to manually rotate the record for a number of rotations before the introduction of the stylus to the groove or guide the stylus in the phonic groove up to the point of sound rendition.

A still further object of the present invention is the provision of a stylus guiding attachment that reinforces the periphery of the record and also by reason of the fact that the stylus guide is formed as a continuation of the phonic groove of the record, whereby the needle is properly guided thereto. It is also found that by forming the stylus receptacle as in the present instance, a projection, the operator, even though operating in a dim or no light, where the device is operated in connection with a projector of a motion picture machine may "feel" the position of the stylus upon the record without any liability of damaging the record.

In the drawings—Fig. 1 is a plan view of a disc record with the present attachment applied thereto. Fig. 2 is an enlarged fragmentary plan view of a portion of the record and the attachment adjacent the stylus receiving portion of the attachment. Fig. 3 is a section taken on line 3-3 of Fig. 1. Fig. 4 is a section taken on line 4-4 of Fig. 1.

60 YEARS' EXPERIENCE

PATENTS

TRADE MARKS
DESIGNS
COPYRIGHTS & C.

Anyone sending a sketch and description may quickly ascertain our opinion free whether an invention is probably patentable. Communications strictly confidential. HANDBOOK on Patents sent free. Oldest agency for securing patents. Patents taken through Munn & Co. receive special notice, without charge, in the

Scientific American.

A handsomely illustrated weekly. Largest circulation of any scientific journal. Terms, \$3 a year; four months, \$1. Sold by all newdealers.

MUNN & Co. 361 Broadway, New York
Branch Office, 625 F St., Washington, D. C.

RECORD BULLETINS FOR DECEMBER, 1914.

COLUMBIA GRAPHOPHONE CO.

- SYMPHONY DOUBLE-DISC RECORDS.
A5605 Der Freischütz (Weber). Wie nahte mir der Schlummer (Ne'er yet by sleep deserted). Soprano Solo, in German, with orch.
A5604 Bohemian Girl (Balfe). "Then You'll Remember Me." Tenor Solo in English, with orch.
A1608 Dream Pictures (Traumbilder). Lumbye. Prince's Orchestra
A1604 Mountain High (Keefe). Yodler Song. Matt Keefe
A1605 A Visit from St. Nicholas (Moore). Recitation. Harry E. Humphrey
A1606 All Hail the Power of Jesus' Name. Harry E. Humphrey
A1607 Fighting Blood March (Sangre Insurgente) (Sanchez). Columbia Band
A1608 It's a Long, Long Way to Tipperary (Judge and Williams) Baritone Solo, orch. accomp. Stanley Kirkby
A1609 Old Comrades March (Teike). Columbia Band
A1615 The Girl from Utah. (Rubens). Columbia Band
A5601 Dance of the Frowsy Heads (Story). Prince's Band
A5602 Buttercup Schottische from "Wild Flower Dance Suite" (Hager). Prince's Band
A5603 Rejoice Greatly, O Daughter of Zion, from "The Messiah" (Handel). Solo by boy-soprano, orch. accomp. Walter Lawrence
A5603 Song of Hybras the Cretan (Elliott). Bass Solo, orch. accomp. Miles Bracewell
A1613 The Land of My Best Girl (The Fatherland, the Motherland) (Carroll). Tenor Solo, orch. accomp. Charles W. Harrison
A1611 After the Roses Have Faded Away (Ball). Tenor Solo, orch. accomp. Henry Burr
A1612 Along Came Ruth (Berlin). Baritone Solo, orch. accomp. Arthur Fields
A1614 Along the Yukon Trail (Jerome). Baritone Solo, orch. accomp. John W. Myers
A5608 Reuben Fox-Trot (Claypoole). Violin and piano duet. Albert and Monroe Jockers
A5609 The Mississippi Barbecue (Reed). One-step. Violin and piano duet. Albert and Monroe Jockers
A5606 Moonglide Waltz (Benyon). Hesitation. Prince's Band
A5607 When It's Night-time Down in Burgundy (Paley). One-step. Prince's Band
A5607 That's Love with a Capital L (Je sais que vous etes jolie) (Christine). Fox-trot. Prince's Band

- (Rubens). Soprano and tenor, orch. accomp. Marie Kaiser and Reed Miller
2482 Hark! The Herald Angels Sing—Christmas Song (Mendelssohn). Organ and orch. accomp. Edison Mixed Quartet
2487 It's a Long, Long Way to Tipperary (Judge and Williams). Baritone and chorus, orch. accomp. Albert Farrington and Male Chorus
2471 I Want to Go Back to Michigan—Fox Trot (Irving Berlin) (For dancing). National Promenade Band
2466 Jocelyn—Lullaby (Godard). Soprano, orch. accomp. Elizabeth Spencer
2465 L'Elégante Polka (Damaré). Xylophone, orch. accomp. Charles Daab
2467 L'Estudiantina—Waltz Hesitation (Waldteufel). (For dancing). National Promenade Band
2463 A Little More Pepper One-step (Lincoln) (For dancing). National Promenade Band
2462 Love's Last Word (Cremieux). Tenor and chorus, orch. accomp. Walter Van Brunt and Chorus
2464 The Night Before Christmas (Moore). Recitation. Harry E. Humphrey
2478 O Come, All Ye Faithful—Christmas Song (Reading). Organ and orch. accomp. Edison Mixed Quartet
2470 Peuben Fox Trot (Claypoole). (For dancing). National Promenade Band
2486 Rule Britannia (Arne). Band, Baritone and chorus
2481 Roses Remind Me of Someone (Schmid). Tenor and chorus, orch. accomp. Arthur C. Clough and Chorus
2483 (a) Russian National Air (Lord God, Protect the Czar) (A. Von Luoff). (b) Belgian National Air (La Brabanconne) (F. Camphenout). New York Military Band
2461 Soldiers of the King (Stuart). Baritone and Chorus, orch. accomp. Jos. A. Phillips and Chorus
2473 Spring of Love (Ehrich). Violin, violoncello, flute and harp. Venetian Instrumental Quartet
2474 Una noche de garufa—Tango (Arolas). (For dancing). New York Military Band

VICTOR TALKING MACHINE CO.

- NEW DANCE RECORDS.
No. Size
35396 When It's Night-time in Burgundy—Medley One-step. Victor Military Band 12
Violets—Waltz Hesitation (E. Waldteufel). Conway's Band 12
35411 Pryor Fox Trot (Arthur Pryor—Arr. M. L. Lake). Victor Military Band 12
Old Homestead Fox Trot (William H. Penn). Victor Military Band 12
35414 Michigan Medley One-step. Victor Military Band 12
My Lady of the Telephone—One-step, from the latest Winter Garden success, "Dancing Around". Victor Military Band 12
35415 Carolina Fox Trot (Will H. Vodery—Arr. Wm. Schulz). Victor Military Band 12
Beets and Turnips Fox Trot (Cliff Hess-Fred Ahlert). Victor Military Band 12
SPECIAL DANCE LIST PUT ON SALE LATE IN OCTOBER.
17644 Free and Easy—Castle Polka (C'est pour rieur) (Rodolphe Berger). Victor Military Band 10
Tanzweise—Castle Polka (Adapted from Meyer-Helmund). Victor Military Band 10
35405 Ballin' the Jack Medley—Fox Trot (Chris. Smith James Reese Europe). Victor Military Band 12
Meadowbrook Fox Trot (Arthur M. Kraus). Victor Military Band 12
35406 Do the Funny Fox Trot (Earl and Harry Carroll). Victor Military Band 12
Bubi Fox Trot (Walter Kollo). Victor Military Band 12
POPULAR SONGS FOR DECEMBER.
17630 If That's Your Idea of a Wonderful Time (Take Me Home) (Irving Berlin). Ada Jones 10
I Can't Believe You Really Like Me (It's Like a Wonderful Dream) (Clarke-Abrahams). Billy Watkins 10
17631 They Start the Victrola (And Go Dancing Around the Floor) (Clarke-Abrahams). Billy Murray 10
What a Wonderful Love that Would Be (Whitting-Cunningham-Doyle). Ada Jones-Billy Murray 10
17641 Come Back to Me (Albert Von Tilzer). Arthur Clough 10
When June-Time Brings the Roses (Robert F. Roden-Henry W. Petrie). Edna Brown-James F. Harrison 10
17649 Do the Funny Fox Trot (Earl and Harry Carroll). Collins and Harlan 10
At the Ball, That's All (J. Leubric Hill). Morton Harvey 10
17650 I Want to Go Back to Michigan (Down on the Farm) (Irving Berlin). Morton Harvey 10
At the Mississippi Cabaret (Brown-Gumble). American Quartet 10
17652 When You Wore a Tulip, and I Wore a Big Red Rose (Jack Mahoney-Percy Wentch). American Quartet 10
The Red, White and Blue (George Arthur-Louis A. Hirsch). Peerless Quartet 10
17654 You're More Than the World to Me (Jeff Pranan-Alfred Solman). George W. Ballard 10
Diane of the Green Van (J. Will Callahan-F. Henri Klickmann). Albert Campbell and Henry Burr 10
TWO BRITISH MEDLEY MARCHES
17651 It's a Long, Long Way to Tipperary—Medley March (Jack Judge-Harry Williams). Victor Military Band 10
Private Tommy Atkins—Medley March (Arr. Carl Engel). Victor Military Band 10
TWO ATTRACTIVE INSTRUMENTAL RECORDS BY TWO FAMOUS EUROPEAN PLAYERS.
17642 Polka Fantastique. Bassoon Solo. Carl Borgwald 10
The Soldier's Dream. Cornet Solo. A. Matthes 10
TWO BEAUTIFUL OLD CHRISTMAS HYMNS.
35412 While Shepherds Watched (Christmas Hymn)

EDISON BLUE AMBEROL RECORDS.

- REGULAR LIST.
2468 The Aha Daba Honey-moon (Field and Donovan). Monkey Song, orch. accomp. Arthur Collins and Byron G. Harlan
2475 Adoration (Borowski). Violin, piano accomp. by Robert Gayler. Richard Czerwonky
2480 Ballin' the Jack—Fox Trot (Smith and Europe) (For dancing). National Promenade Band
2476 The Birthday of a King—Christmas Song (Neidlinger) Baritone and Chorus, orch. accomp. Thomas Chalmers and Chorus
2472 Come to Me (Heltman). Contralto and Baritone, orch. accomp. Helen Clark and Vernon Archibald
2469 (a) Die Wacht am Rhein; (b) Deutschland über Alles—Male voices. Manhattan Quartet
2479 Do the Funny Fox Trot (Earl and Harry Carroll) (For dancing). National Promenade Band
2477 The Music of Love, from "The Girl from Utah"

- (Hymn by Nahum Tate, 1702-Air Arr. from G. F. Handel, 1728). Victor Oratorio Chorus
It Came Upon the Midnight Clear—Christmas Hymn (Poem by Rev. E. H. Sears, 1850—Tune by Richard S. Willis, 1850). Victor Oratorio Chorus 12
A FINE ACCORDEON AND MANDOLIN DOUBLE.
17643 "Italian Favorites" 1. "La Spagnole," 2. "Ciribiribin" (Accordeon). Pietro Deiro 10
Azalea Waltz (B. Hartz) (Mandolin with piano). Dr. Clarence Penney 10
TWO FAVORITE "GEMS" NOW IN DOUBLE FACE.
35410 Gems from "Madame Sherry" (Hauerback-Hoschna). Victor Light Opera Co. 12
Gems from "The Quaker Girl" (Ross-Greenbank-Monckton). Victor Light Opera Co. 12
5861 Let Us Have Peace (Graff-Ball) Baritone Solo. Reinald Werrenrath 10
NEW EDUCATIONAL RECORDS.
17646 1. Psalm 107 (Tune "Dundee"); 2. Psalm 100 (Tune "Old Hundred") from "The Bay Psalm Book"—(The fifth book). Lyric Quartet 10
1. Mear (Barnard), 2. Lenox (Lewis Edson), 3. Windham (Daniel Read), 4. China (Swan), Nos. 1, 3 and 4 from "American Tune Book" No. 2 from Methodist Hymnal. Lyric Quartet 10
17647 Nazareth, from "Christmas Carols and Hymns" (Gounod—Arr. Johnston) (Pub. American Book Co.). Lyric Quartet 10
The First Nowell (Traditional) from "Christmas Carols and Hymns" (Compiled by Hollis Dann) (Pub. American Book Co.). Lyric Quartet 10
BLUE LABEL RECORDS.
FOUR NEW SONG BIRD RECORDS.
Actual Songs of Birds in the Aviary of Karl Reich, of Bremen.
45057 Song of a Nightingale, No. 2. 10
Song of a Thrush (German, Drossel). 10
45058 Song of a Sprosser (Also called "Field Nightingale"). 10
Canary and Thrush Duet. 10
PURPLE LABEL RECORDS.
60126 The Last Rose of Summer (Moore) Soprano Solo. Lucy Marsh 10
70111 Your Eyes (W. B. Johnson-W. R. Anderson) Baritone Solo. George MacFarlane 12
NEW RED SEAL RECORDS.
64409 Gioconda—Ciel a mar (Heaven and Ocean) (Act II) (Ponchielli) Tenor Solo. Giovanni Martinelli 10
64418 Auld Lang Syne. (Burns) Contralto Solo. Julia Culp 10
64422 Comin' Thro' the Rye (Scottish Air) Soprano Solo. Alma Gluck 10
64426 My Wild Irish Rose (Chauncey Olcott) Tenor Solo. John McCormack 10
64438 Vogel als Prophet, from "Waldscenen" Op. 82, No. 7. Violin Solo (pianoforte by Percy B. Kahn) (Robert Schumann). Mischa Elman 10
64444 Heimweh (Longing for Home) (Eichendorff-Hugo Wolf) Contralto Solo (pianoforte by Arthur Arndt) In German. Margarete Ober 10
64468 Lucrezia Borgia—Brindisi (Drinking Song—It is Better to Laugh) (Act III) (Donizetti) Contralto Solo in Italian. Sophie Braslau 10
74898 Aida—O terra addio (Final duet. "Farewell, Oh Earth") (Act IV) (Verdi) Soprano and Tenor Duet in Italian. Lucy Isabelle Marsh and John McCormack 12
74401 Love's Own Sweet Song, from "Sari" (C. S. Cushing-E. P. Heath-E. Kalman) Soprano Solo (pianoforte by Frank La Forge). Frances Alda 12
87189 Niña Pancha Americana (Romea y Valverde) Soprano Solo in Spanish. Lucrezia Bori 10
87511 Traviata-Brindisi-Libiam nei lieti calici (A Bumper We'll Drain) (Act I) (Verdi) Tenor and Soprano Duet with Metropolitan Opera Chorus, in Italian. Enrico Caruso and Alma Gluck 10
89082 Rigoletto—"Figlia! Mio padre!" (My Daughter) (Act I) (Verdi) Soprano and Baritone Duet, in Italian. Frieda Hempel and Pasquale Amato 12

NEW MERCHANDISING HELP.

New York Talking Machine Co. Issues Gummed Strips of All Numbers in Monthly Victor Record Supplements for Use of Dealers.

The New York Talking Machine Co., 81 Chambers street, New York, Victor distributor, has just completed a new plan which should prove of considerable practical value to its many dealers. This company has from time to time perfected various innovations or ideas in Victor merchandising which has added to the dealer's profits directly and indirectly, and the latest idea is in accord with the originality of the previous plans announced by the company.

This most recent innovation is the issuance of gummed strips of all the numbers in the monthly Victor record supplements as these supplements are issued. The strips are perforated so that each number will tear off easily, and be conveniently attached to the dealer's stock envelopes. The company's dealers will be supplied with these strips monthly in the future. The advantages of these numbered strips are many, as they enable the dealer to keep his stock envelopes clean and fresh at all times and show plainly the number of the new record without any possibility of confusion or doubt. Those of the New York Talking Machine Co.'s dealers who have been informed of the new plan have commended it from every standpoint.

SCHEDULES IN SPIEGEL FAILURE.

Schedules in bankruptcy have been filed by Benjamin Spiegel, dealer in talking machines at 28 Delancey street, New York, which show liabilities of \$4,801 and assets of \$5,095, consisting of stock, \$1,300; accounts, \$3,490, and fixtures, \$300; cash in bank, \$5.

CHEMISCHE FABRIK E. SAUERLANDT FLURSTEDT bei Apolda i. Th., Germany
The largest manufacturing plant in the world devoted exclusively to the manufacture of Master-Waxes and Master-Blanks for Gramophone and Phonograph Recording
Sole Manufacturer of Wax "P." the best recording material for Berliner-cut.

Leading Jobbers of Talking Machines in America

1856 **WURLITZER** 1914

VICTOR
DISTRIBUTERS
VICTORS EXCLUSIVELY

We make a specialty of getting the order out on time—every time.

The Rudolph Wurlitzer Co.
CINCINNATI and CHICAGO

Two points of supply; order from the nearer.

PERRY B. WHITSIT L. M. WELLER
PERRY B. WHITSIT CO.,
213 South High Street, Columbus, Ohio.

Edison Phonographs and Records **JOBBERS** Victor Talking Machines and Records

OLIVER DITSON COMPANY
BOSTON

Largest VICTOR Talking Machine Distributors East of Chicago.
Creators of "The Fiestest Victor Service." Let us tell you more about our service.

W. J. DYER & BRO.
Saint Paul, Minn.

VICTOR & EDISON
Distributors

Quick Service for all points in the Northwest. Machines, Records, Supplies.

Do you belong with—"the quick or the dead"

Every talking machine jobber in America should be represented in The World of December 15th.

If you are keenly alive to your business interests you will be with the live ones and occupy space in the issue of The World of that date.

The time to secure space is now, and get your copy in at once. Don't be a "dead one."



Where Dealers May Secure

COLUMBIA

Product

Ready, Full Stocks, and Prompt Deliveries from Convenient Shipping Centers all over the United States.

Distributors

Atlanta, Ga., Columbia Graphophone Co., 132 Peachtree St.
Baltimore, Md., Columbia Graphophone Co., 305-307 North Howard St.
Birmingham, Ala., Columbia Graphophone Co., 1818 Third Ave.
Boston, Mass., Columbia Graphophone Co., 174 Tremont St.
Buffalo, N. Y., Columbia Graphophone Co., 622 Main St.
Chicago, Ill., Columbia Graphophone Co., 14 N. Michigan Ave.
Cincinnati, O., Columbia Graphophone Co., 117-119 W. Fourth Ave.
Cleveland, O., Columbia Graphophone Co., 1375 Euclid Ave.
Dallas, Tex., Southwestern Talking Machine Co., 1101 Elm St. Columbia Building.
Denver, Colo., Columbia Stores Co., 505-507 Sixteenth St.
Detroit, Mich., Columbia Graphophone Co., 114 Broadway.
Hartford, Conn., Columbia Graphophone Co., 719 Main St.
Indianapolis, Ind., Columbia Graphophone Co., 27 N. Pennsylvania St.
Kansas City, Mo., Columbia Graphophone Co., 1132 Grand Ave.
Lincoln, Nebr., The Grafonola Company, 1036 O St.
Livingston, Mont., Scheuber Drug Co.
Los Angeles, Cal., Columbia Graphophone Co., 420-422 S. Broadway.
Louisville, Ky., Columbia Graphophone Co., 425 South Fourth St.
Milwaukee, Wis., Albert G. Kunde, 615 Grand Ave.
Minneapolis, Minn., Columbia Graphophone Co., 424 Nicollet Ave.
New Haven, Conn., Columbia Graphophone Co., 26 Church St.
New Orleans, La., Columbia Graphophone Co., 933 Canal St.
New York City, Columbia Graphophone Co., 89 Chambers St.
Philadelphia, Pa., Pennsylvania Talking Mach. Co., 1100 Chestnut St.
Pittsburgh, Pa., Columbia Graphophone Co., 101 Federal St.
Portland, Me., Columbia Graphophone Co., 550 Congress St.
Portland, Ore., Columbia Graphophone Co., 371 Washington St.; Ellers Music House.
Providence, R. I., Columbia Graphophone Co., 119 Westminster St.
Rochester, N. Y., The Grafonola Company, 23 Clinton Ave., South.
Sacramento, Cal., Kirk, Geary & Co.
Salt Lake City, Utah, Daynes-Beebe Music Co., 45 Main St.
San Francisco, Cal., Columbia Graphophone Co., 334 Sutter St.
Seattle, Wash., Columbia Graphophone Co., 1311 First Ave.; Ellers Music House, 3d and University Sts.
Spokane, Wash., Columbia Graphophone Co., 818 Sprague Ave.
Springfield, Mass., Columbia Graphophone Co., 174 Worthington St.
St. Louis, Mo., Columbia Graphophone Co., 1003 Olive St.
St. Paul, Minn., Columbia Graphophone Co., 17 East Sixth St.
Tampa, Fla., Tampa Hardware Co.
Terre Haute, Ind., 640 Wabash Ave.
Toledo, O., Columbia Graphophone Co., 229 Superior St.
Washington, D. C., Columbia Graphophone Co., 1210 G St., N. W.

DEALERS WANTED—Exclusive selling rights given where we are not actively represented.

Write for particulars to the Columbia Graphophone Co., Wholesale Department, Woolworth Building, New York.

Headquarters for Canada:
Columbia Graphophone Co., 363-5-7 Sorauren Ave.
Toronto, Ont.

Southern Victor Dealers
Largest Stock VICTROLAS and RECORDS.
Prompt Shipments and Low Freight Rates.

WALTER D. MOSES & CO.
Oldest Music House in Virginia or North Carolina.
RICHMOND, VA.

SERVICE FIRST

EXCLUSIVE VICTOR JOBBERS
WHOLESALE ONLY

Standard Talking Machine Co.
PITTSBURGH, PA.

Edison Phonograph Distributors
for the SOUTHWEST
All Foreign Records in Stock.

Houston Phonograph Co., HOUSTON, TEXAS

NEW ENGLAND
JOBBER HEADQUARTERS
EDISON AND VICTOR
Machines, Records and Supplies.
THE EASTERN TALKING MACHINE CO.
177 Tremont Street BOSTON, MASS.

PACIFIC COAST DISTRIBUTORS OF
Victor Talking Machines and RECORDS
STEINWAY PIANOS—LYON & HEALY
"OWN MAKE" BAND INSTRUMENTS

Sherman, Clay & Co. San Francisco Oakland Portland Los Angeles

The Chicago Edison Jobber

The perfection of Musical Instruments—THE EDISON diamond disc PHONOGRAPH—with EDISON double disc records.

THE PERFECTION OF SERVICE—Our Service.

The Perfection of advertising for the dealer—Our plan.

The Phonograph Company
229 So. Wabash Ave. CHICAGO

CHASE & WEST DES MOINES IOWA

Machines Records Cabinets **Victor** Everything in stock all the time.

WHOLESALE TO IOWA TRADE

Send us your name and address and we will mail you postpaid complete illustrated catalogues, giving detailed information concerning all Victor products. Showing the various styles of Victor Machines, list of all Victor Records, the entire line of Victor Cabinets, Repair Parts and all Accessories. Dealers, let us help you build a Victor Business.

“Tell him what he
wants to hear”

“Sell him what he
wants to buy”

These two basic selling rules
were old when the world
was young. You use them
with the utmost freedom in
selling the full Edison Line
because of its tremendous
variety of talking points.

No matter what your cus-
tomer's tastes, you can
always find some Edison
superiority he's been wanting
to hear about and so you
can *always* sell him what
he wants to buy.



Edison Disc and Cylinder Phonographs



Thomas A Edison
INCORPORATED

59 Lakeside Ave., ORANGE, N. J.

The TALKING MACHINE WORLD



Published Each Month by Edward Lyman Bill at 373 Fourth Avenue, New York, December 15, 1914



The best-known trade mark in the world

"The Victor talking machine's design, 'His Master's Voice,' has become a household word, and the quaint little fox terrier at attention before the horn is familiar to more Americans than any of the world's great masterpieces"—*Collier's Weekly*.

Leading Jobbers of Talking Machines in America

SERVICE FIRST

EXCLUSIVE VICTOR JOBBERS
WHOLESALE ONLY

Standard Talking Machine Co.
PITTSBURGH, PA.

Edison Phonograph Distributors

for the SOUTHWEST
All Foreign Records in Stock.

Houston Phonograph Co., HOUSTON, TEXAS

NEW ENGLAND JOBGING HEADQUARTERS EDISON AND VICTOR

Machines, Records and Supplies.
THE EASTERN TALKING MACHINE CO.
177 Tremont Street BOSTON, MASS.

PACIFIC COAST DISTRIBUTORS OF

Victor Talking Machines and RECORDS
STEINWAY PIANOS—LYON & HEALY
"OWN MAKE" BAND INSTRUMENTS
Sherman, Clay & Co. San Francisco Portland
Oakland Los Angeles

The Chicago Edison Jobber

The perfection of Musical Instruments—THE EDISON diamond disc PHONOGRAPH—with EDISON double disc records.

THE PERFECTION OF SERVICE—Our Service.

The Perfection of advertising for the dealer—Our plan.

The Phonograph Company
229 So. Wabash Ave. CHICAGO

CHASE & WEST DES MOINES IOWA

Machines Everything
Records **Victor** in stock all
Cabinets the time.

WHOLESALE TO IOWA TRADE

Send us your name and address and we will mail you postpaid complete illustrated catalogues, giving detailed information concerning all Victor products. Showing the various styles of Victor Machines, list of all Victor Records, the entire line of Victor Cabinets, Repair Parts and all Accessories. Dealers, let us help you build a Victor Business.



Where Dealers May Secure

COLUMBIA

Product

Ready, Full Stocks, and Prompt Deliveries from Convenient Shipping Centers all over the United States.

Distributors

Atlanta, Ga., Columbia Graphophone Co., 132 Peachtree St.
Baltimore, Md., Columbia Graphophone Co., 305-307 North Howard St.
Birmingham, Ala., Columbia Graphophone Co., 1313 Third Ave.
Boston, Mass., Columbia Graphophone Co., 174 Tremont St.
Buffalo, N. Y., Columbia Graphophone Co., 622 Main St.
Chicago, Ill., Columbia Graphophone Co., 14 N. Michigan Ave.
Cincinnati, O., Columbia Graphophone Co., 117-119 W. Fourth Ave.
Cleveland, O., Columbia Graphophone Co., 1375 Euclid Ave.
Dallas, Tex., Southwestern Talking Machine Co., 1101 Elm St. Columbia Building.
Denver, Colo., Columbia Stores Co., 505-507 Sixteenth St.
Detroit, Mich., Columbia Graphophone Co., 114 Broadway.
Hartford, Conn., Columbia Graphophone Co., 719 Main St.
Indianapolis, Ind., Columbia Graphophone Co., 27 N. Pennsylvania St.
Kansas City, Mo., Columbia Graphophone Co., 1112 Grand Ave.
Lincoln, Nebr., The Grafonola Company, 1036 O St.
Livingston, Mont., Scheuber Drug Co.
Los Angeles, Cal., Columbia Graphophone Co., 420-422 S. Broadway.
Louisville, Ky., Columbia Graphophone Co., 425 South Fourth St.
Milwaukee, Wis., Aihert G. Kunde, 615 Grand Ave.
Minneapolis, Minn., Columbia Graphophone Co., 424 Nicollet Ave.
New Haven, Conn., Columbia Graphophone Co., 25 Church St.
New Orleans, La., Columbia Graphophone Co., 933 Canal St.
New York City, Columbia Graphophone Co., 89 Chambers St.
Philadelphia, Pa., Pennsylvania Talking Mach. Co., 1100 Chestnut St.
Pittsburgh, Pa., Columbia Graphophone Co., 101 Federal St.
Portland, Me., Columbia Graphophone Co., 550 Congress St.
Portland, Ore., Columbia Graphophone Co., 371 Washington St.; Eilers Music House.
Providence, R. I., Columbia Graphophone Co., 119 Westminster St.
Rochester, N. Y., The Grafonola Company, 23 Clinton Ave., South.
Sacramento, Cal., Kirk, Geary & Co.
Salt Lake City, Utah, Daynes-Beebe Music Co., 45 Main St.
San Francisco, Cal., Columbia Graphophone Co., 334 Sutter St.
Seattle, Wash., Columbia Graphophone Co., 1311 First Ave.; Eilers Music House, 3d and University Sts.
Spokane, Wash., Columbia Graphophone Co., 818 Sprague Ave.
Springfield, Mass., Columbia Graphophone Co., 174 Worthington St.
St. Louis, Mo., Columbia Graphophone Co., 1008 Olive St.
St. Paul, Minn., Columbia Graphophone Co., 17 East Sixth St.
Tampa, Fla., Tampa Hardware Co.
Terre Haute, Ind., 640 Wahash Ave.
Toledo, O., Columbia Graphophone Co., 229 Superior St.
Washington, D. C., Columbia Graphophone Co., 1210 G St., N. W.

DEALERS WANTED—Exclusive selling rights given where we are not actively represented.

Write for particulars to the Columbia Graphophone Co., Wholesale Department, Woolworth Building, New York.

Headquarters for Canada:

Columbia Graphophone Co., 363-5-7 Sorauren Ave.

Toronto, Ont.

Southern Victor Dealers

Largest Stock VICTROLAS and RECORDS.
Prompt Shipment and Low Freight Rates.

WALTER D. MOSES & CO.
Oldest Music House in Virginia or North Carolina.
RICHMOND, VA.

1856 WURLITZER 1914

VICTOR DISTRIBUTERS VICTORS EXCLUSIVELY

We make a specialty of getting the order out on time—every time.

The Rudolph Wurlitzer Co.
CINCINNATI and CHICAGO

Two points of supply; order from the nearer.

PERRY B. WHITSIT

L. M. WELLER

PERRY B. WHITSIT CO.,

213 South High Street.

Columbus, Ohio.

Edison Phonographs and Records

JOBBERS

Victor Talking Machines and Records

OLIVER DITSON COMPANY

Largest VICTOR Talking Machine Distributors East of Chicago.

Creators of "The Fastest Victor Service." Let us tell you more about our service.

BOSTON

W. J. DYER & BRO.

Saint Paul, Minn.

VICTOR & EDISON Distributors

Quick Service for all points in the Northwest. Machines, Records, Supplies.

Do you belong with—"the quick or the dead"

Every talking machine jobber in America should be represented in The World of January 15th.

If you are keenly alive to your business interests you will be with the live ones and occupy space in the issue of The World of that date.

The time to secure space is now, and get your copy in at once. Don't be a "dead one."

The Talking Machine World

Vol. 10. No. 12.

New York, December 15, 1914.

Price Ten Cents

ST. LOUIS ASSN. ON FIRM BASIS.

Trade Organization Now Affiliated with Missouri Retail Merchants' Association and Enjoys All the Facilities of That Body.

(Special to The Talking Machine World.)

St. Louis, Mo., December 7.—The St. Louis Talking Machine Dealers' Association has succeeded in getting on a firmer foundation than was anticipated in last month's report. After the plan was completed five of the talking machine dealers had arranged to join the Missouri Retail Merchants' Association and to be appointed on a talking machine committee which would enable them to use the association equipment and to call the other dealers into conference with them, the larger association decided that it would be better to carry out the original plan and establish a special membership for the talking machine dealers on a basis of employees, and so all of the dealers have become identified with the larger association and now there is no question about the use of the office staff and equipment. The workings of this office staff have been a constant surprise to the members.

When the need of a resolution or other agreement is felt the members thresh it out in a meeting, the professional and expert secretary of the larger association disappears for a moment while an assistant takes up his work and returns with a resolution properly dictated, typewritten, and if it is such a resolution that each member would have a copy, the required number of copies are ready before the meeting adjourns. Each employe of the larger association is an expert in some line, and when work along that line is required that employe is at hand and they are quick to point out faults of proposed movements. For the present the association will devote its efforts to strengthening price and return terms, which are being well received by the trade and which, dealers say, are not causing any loss of trade and promoting a better understanding between all dealers. The Missouri association, which is the parent body, includes practically all of the large department stores, and it is through this association that the railroad fares for out-of-town customers are refunded under certain conditions.

SEMI-ANNUAL COLUMBIA CATALOG

As Ever, More Complete and Interesting Than Previous Issues of Similar Volume—Emphasizes Growth of Record Library.

The Columbia Graphophone Co. issued last week its regular semi-annual catalog of Columbia records, listing all the records issued up to date. This publication, which is the most important book issued by the company, is similar to the previous edition of the Columbia record catalog, as the company found, by making inquiry of its dealers throughout the country, as that the form and design of the last semi-annual catalog was perfect in every detail and did not permit of any practical improvement.

The catalog is divided into three parts: First, a partial list of grand opera and concert selections; second, a general catalog of double-disc records, alphabetically arranged; third, a list of special school series records. The method of indexing followed in this catalog includes numerous cross indexing and listing, enabling the record purchaser to locate a record with maximum convenience and ease. The system of indexing is so complete that each record is listed under six to eight different headings.

The growth of the Columbia record library is concretely set forth in this new publication, as a number of prominent and renowned artists have their first Columbia recordings listed in this edition. More than eight pages of the catalog are devoted exclusively to Columbia dance records,

these records including selections for all the modern dances, and well illustrating the progress being achieved by the Columbia Co. in this particular field.

HERE'S THE ORIGINAL TURKEY TROT.

National Dinner Birds Dance to Music of Phonograph and Gobble for More.

(Special to The Talking Machine World.)

BOISE, IDAHO, December 9.—Pleasure seekers on the mesa recently witnessed a genuine turkey trot. One of a group of equestrians was Probation Officer Lowe, of the Juvenile Court.

One of Mr. Lowe's special duties is to see that turkey trotting is not permitted in the city, it being against the ordinance, but despite the fact that this turkey trotting was outside the city limits, Mr. Lowe concluded that he had better inspect it. He is now glad he did so, for he has come to the conclusion that the turkey is the most maligned bird on earth, that genuine turkey trotting is not vulgar in the least, but is quite a dignified pastime.

This particular turkey trot was held at one of the country homes in the mesa close to town. The house has a large loggia, which is screened in and extends across the entire side of the house. On this loggia was stationed a large phonograph, to the music of which a group of friends were dancing.

Crowded close to the side of the loggia was a flock of forty or more turkeys, glossy and sleek, in prime readiness for the table.

"The turkeys apparently were fascinated by the catchy ragtime music," said Mr. Lowe, "and they moved about in the funniest way imaginable. They would one-step to the right, then turn their heads, craning their long necks to see what the other fowls thought of their behavior. Then they would one-step to the left, again craning their necks, sometimes giving a little hitchy jump in between and an occasional 'cluck'."

"You can imagine," said Mr. Lowe, "the effect of some forty or fifty turkeys all going through these peculiar motions to the music of 'Too Much Mustard' and 'Your'e Here and I'm Here.' The minute the music would stop those turkeys would get up the greatest gobbling you ever heard and keep it up until the phonograph started again. I could imagine something of what they were saying expressing their delight at the new style of music, I suppose."

MAY BE MEMORY CHAMPION.

Friends of Hyman Landau, Talking Machine Man of Wilkes-Barre, Pa., Declare He Has Best Memory in the City—Proof Submitted.

(Special to The Talking Machine World.)

WILKES-BARRE, PA., December 8.—In a proposed contest to decide what man has the best memory in the city of Wilkes-Barre, Hyman Landau, of the Landau Music & Jewelry Store, is supported by many of his fellow citizens, who declare that he will carry off the honors in that line very easily.

Mr. Landau is credited with being able to give without hesitation the number of any record in the catalog of the Victor Talking Machine Co. once he is acquainted with the name of the selection desired. It is stated that a customer entered the Landau store recently and gave a list of records desired. Mr. Landau did not have to look up a single number, but when he came to a certain selection informed the customer that he had already purchased that record before. The customer denied the fact, but was persuaded to call up his home and found that the talking machine man was right.

Mr. Landau's chief competitor for the memory prize is John T. Lenahan, one of the most noted criminal attorneys in the State and also a former Congressman, who is credited with a remarkable memory regarding legal matters.

GOOD PROSPECTS IN COLORADO.

Denver Houses Giving Over Additional Space to Talking Machine Departments and Big Shipment of Records Is Received in Grand Junction—Knight-Campbell Co.'s New Rooms.

(Special to The Talking Machine World.)

DENVER, COL., December 7.—The present talking machine business and the outlook in that line in this city is of a most satisfactory character and there is little doubt at present that with the holiday business already in sight the total for the month of December will, with the majority of concerns, prove considerably in excess of the sales volume for the same period of last year.

Several of the local dealers have made special preparation to feature the talking machine trade for the holidays, among them being the Knight-Campbell Music Co., which only a week or so ago completed and threw open to the public sixteen commodious and handsome demonstrating rooms for Victrolas. The extra rooms have been badly needed to handle the increasing Victor business of the company.

Another house which has made recent improvements in its talking machine department is the Denver Music Co. Several new demonstration booths have been added to the company's department on the second floor of its building, which now embraces over 12,500 square feet of floor space.

The H. W. Vorbeck Music Co., of Grand Junction, Col., has installed a big stock of Victor goods to take care of holiday demands, and only recently received the largest shipment of Victor records which ever went to that city.

NEW QUARTERS IN LAKEWOOD, N. J.

George Hurlburt, Victor Dealer, Now Located in Larger and More Convenient Store.

(Special to The Talking Machine World.)

LAKEWOOD, N. J., December 7.—George Hurlburt, the successful talking machine and piano dealer of this city, is now located in a handsome new building on Second street. The new structure, built of stucco, occupies the site of Mr. Hurlburt's former store, and, in addition to affording additional floor space for display of the line, has been designed to meet the particular requirements of the talking machine and music business.

The equipment of the new store includes modern indirect lighting system, three attractive demonstration booths for the talking-machine department, a new set of record racks with an up-to-date filing system, and other features that make for convenience and efficiency. In addition to Victrolas and records, Mr. Hurlburt also handles the Hallet & Davis Co. line of pianos, and a large assortment of toys.

MUSIC TO SOOTHE JURORS.

Washington Judge Sends Graphophone to Men Locked Up.

(Special to The Talking Machine World.)

WASHINGTON, D. C., December 5.—A jury sitting in a murder trial in Criminal Court No. 1 here, and which was locked up last night until Monday morning, got a fit of the glooms to-day and sent word to Chief Justice Covington that they wanted to do something to occupy their minds. Chief Justice Covington expressed sympathy with the jury and sent word that he would do something.

This evening the Chief Justice sent the jury a graphophone and a set of records and to-night from the court house window there is floating out all kinds of tunes, and the members of the jury are doing all kinds of two steps and can-cans in the corridors of the City Hall.

The easier it is to get a man to make a promise the harder it is to get him to make good.

MANY NEW TALKING MACHINE DEALERS IN DETROIT.

Leading Lines of Machines Well Represented in That City and Vicinity—Steadily Increasing Number of Piano Houses Handling Talkers—December Business Exceeding Expectations—Some Elaborate Window Displays—Revival of Interest in Small Styles.

(Special to The Talking Machine World.)

DETROIT, MICH., December 7.—F. A. Denison, for the past three years manager of the Columbia store in Baltimore, has succeeded K. M. Johns as manager of the Detroit store, Mr. Johns going to the Chambers street store in New York. Mr. Denison's first month here was a record breaker, and an augury for a prosperous future. November business exceeded the November business of last year by \$8,000, and exceeded the December business of last year by several thousands, thus making it the biggest month in the history of the Detroit branch of the company.

The new styles of the machines, of which the improved sounding board is the feature, are going exceedingly well, and this is largely the cause of the increase, though a certain contest system, inaugurated by Manager Denison, has a good deal to do with it. Mr. Denison each month offers prizes for the members of the sales force who make the best records in certain respects, the conditions being altered each month. In November the man who showed the largest percentage of increase won a new hat. This month a certain figure has been set for each man to try for, the estimate being based on past performances, and if he reaches it, he will win a pair of shoes. S. E. Lind won the new hat in the last contest. Mr. Denison says he expects to pay for about ten pairs of shoes on the holiday month, if early indications are any criterion.

"December will be a wonder, if we can get the goods to fill the dealers' orders," he said. "We are having the orders of up-State dealers shipped direct. I think Detroit and Michigan constitute a great field for the Grafonola business. We handle only a part of Michigan, the Western part of the State being in control of the Chicago branch, yet we have done more here since I came than we did in Baltimore, where we controlled three States. Detroit people seem to have money and be willing to spend it."

Four new Detroit accounts were opened by Manager Denison in November, and twenty in the smaller cities of the State. Of the Detroit accounts, that of J. Henry Ling is the largest, he putting in a special department, with seven demonstrating rooms, and handling only the Grafonola line. Though Mr. Ling handled the Columbia for the greater part of November, the contractor, who did the remodeling of the fourth floor, did not get the work done until December 1, so the for-

mal opening of the new department had to be postponed. Formal invitations were sent out, and on December 5 the new Grafonola store was introduced to the public.

R. B. Barclay, a Columbia traveling man, was present, and will remain at the Ling store throughout December, to pilot the venture through its first holiday trade. Miss Sarah Moorhouse is office manager of the department and in charge of the records, of which a complete catalog has been installed.

Besides the seven demonstrating rooms, there is a large reception room, decorated in Japanese style, with bamboo chairs, ceiling and other effects. A sure-enough Japanese girl served tea there at the opening. In one corner is a Grafonola grand.

The other Detroit accounts opened by the Columbia Co. are the Noble Piano Co., which operates two stores; the Cable Piano Co., which also handles the Victrola line, and the Highland Park Furniture Co., which has a large and modern store in the suburb Henry Ford has made famous.

Wallace Brown, manager of the new Edison Shop, and Max Strasburg, manager of the Victrola Shop, who are old-time friends, exchanged pleasantries when the last issue of the Talking Machine World reached them. "The story was all right except the headline," said they both. The headline stated that it was the Max Strasburg Co. which has opened the new Edison shop. "The headline was in the biggest type, so a good many people got the idea that I had taken on the Edison line," remarked Mr. Strasburg. "Well, let them think it. No harm done. Edison is a great man, and I should have been much pleased to meet him, as the headline says I did.

"Mr. Strasburg is all right. We have no objection to honoring him. But we have the Edison, and we did a very flattering business with them for an initial month," said Mr. Brown. "It seems to be regular trade, too, not a holiday rush, for we have sent out all the machines as soon as we sold them, and have yet to store away our first one for a Christmas present. I think we will get plenty of such orders later, however."

December has opened up well for the Edison shop, both in machines and records.

Max Strasburg stated that his business for November was 25 per cent. better than in November of last year. This fact, taken in connection with the experience of the Grafonola store, indicates that Detroit is every bit as prosperous as

she has been pictured. While there are a good many men out of work, business does not seem to be affected by that condition. It is believed that most of the idle men have come here from other cities. It became known a few weeks ago that the city was to begin a number of large public jobs this month, in order to keep Detroiters employed throughout the winter. These contracts will aggregate \$5,000,000 in value, and unemployed men from other cities immediately headed for Detroit to try to get work. But those jobs are for men who engage in summer vocations and ordinarily would be out of work in winter.

General business is so good that the business and professional men feel no need of retrenching. It is the business and professional men, principally, who patronize the down town talking machine stores. They are buying more liberally than ever before, showing that they have confidence in the business situation.

"Last December will be hard to beat, for we had a remarkable month," said Mr. Strasburg. "But we hope to put the holiday record of last year into the shade."

Elaborate window displays are a feature of this year's holiday talking machine business. Grinnell Bros., Victor jobbers, have devoted an entire window to them. Summerfield & Hecht have a window of their big store fixed up with a Grafonola display. The W. E. Metzger Co. has a Victrola display in its show window, in which a miniature ebony minstrel is attached to one of the machines by a wire and dances to the music. This always has an appreciative audience. The Story & Clark Piano Co., which has taken on the Edison line, also gives the talkers liberal space in the windows. So does Frank J. Bayley.

An unexpected turn to the trade here is a revival of interest in the small styles, in quarters where the prevailing demand has been for the expensive ones. The secret is in the growing use of talking machines for dancing purposes. A family may have a \$200 machine in the library, but it is considerable of a task to move it upstairs to a ball room, or to any other room that might be used for dancing. A small machine, easy to tote around the house, therefore, is in demand.

More and more do the piano houses realize the necessity, or at least, the advisability of handling talking machines to round out their business. Two years ago only Grinnell Bros. and the Cable Piano Co. had talking machine lines. Since then the J. L. Hudson Co., Frank J. Bayley, J. Henry Ling, the Noble Piano Co., the Story & Clark have added talking machine lines, all but the last named being prominent members of the Detroit Music Trades' Association. A number of smaller piano stores also have taken on talkers.

Service Is the Paramount Asset of a Victor Distributor

The factory controls the Prices and Terms.

The distributor controls his Service.

This is the reason we have endeavored to make

EASTERN SERVICE THE BEST EVER

And we believe we have succeeded, and will convince you if you will give us the opportunity. A trial order will do.

Will you do it?

Thank you.

When may we expect it?

EASTERN TALKING MACHINE COMPANY

177 TREMONT STREET, BOSTON, MASS.

EDISON

FOR NINETEEN YEARS TALKING MACHINES EXCLUSIVELY

VICTOR

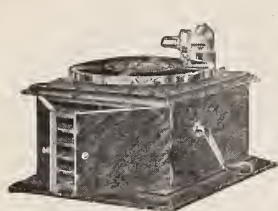

Victrola IV, \$15
Oak



Victrola VI, \$25
Oak



Victrola VIII, \$40
Oak

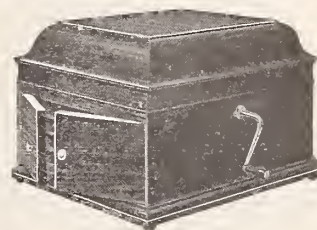

Victrola IX, \$50
Mahogany or oak



“Will there be a Victrola in your home this Christmas?”

This important question is confronting the people of the whole country.

It is the key-note of our nation-wide holiday advertising campaign, and its force is sending thousands of customers into the stores of Victor dealers everywhere.

It is helping to make this the biggest holiday season you ever had—even ahead of the phenomenal business of last Christmas.

Victor Talking Machine Co., Camden, N. J., U. S. A.

Berliner Gramophone Co., Montreal, Canadian Distributors

Always use Victor Machines with Victor Records and Victor Needles—the combination. There is no other way to get the unequalled Victor tone

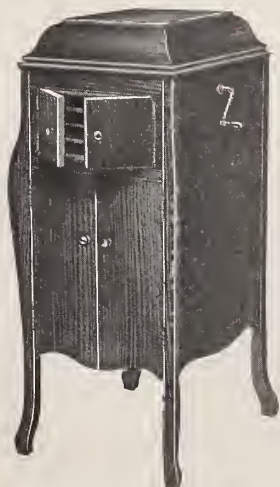

Victrola X, \$75
Mahogany or oak



Victrola XI, \$100
Mahogany or oak



Victrola XIV, \$150
Mahogany or oak



Victrola XVI, \$200
Mahogany or oak

FAMOUS RECORD ALBUMS

AT VERY LOW PRICES TO MEET COMPETITION

These Record Albums will Pay for Themselves in a short Time by Preserving Records. When Full the Albums are Flat and Even Like Books. They will Fit in a Library Cabinet or Book Case, or They will Lie Flat on One Another.

We manufacture Disc Record Albums containing 12 pockets to fit the new Victrola Cabinets No. X. and XI.

We also make Albums containing 17 pockets, and with the indexes these Albums make a complete system for filing all disc Records.

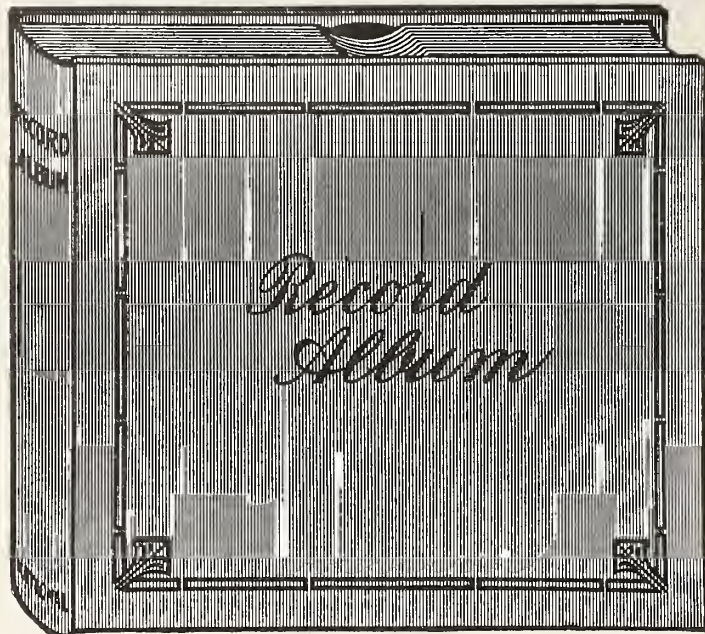

For Durability, Artistic Design and Finish, our Albums have no equal. They are made in the most substantial manner by skilled workman. We sell our Superb Albums at big discounts to meet competition. Shall we send samples and quote our very low prices?

THESE ALBUMS ARE THE BEST FOR VICTOR, EDISON, COLUMBIA AND ALL OTHER DISC RECORDS

Write for samples of our Albums, which are superior to all others

Address NATIONAL PUBLISHING CO., 235 South American St., Philadelphia, Pa.

ATTRACTIVE WINDOW DISPLAY IN LOS ANGELES.

Exhibition of Complete Line of Edison Disc Phonographs in Big Show Window of Barker Bros., That City, Serves to Halt Passing Throng and Results in Many Sales.

(Special to The Talking Machine World.)

LOS ANGELES, CAL., December 4.—A recent window display by Barker Bros., this city, featuring their talking machine department, has attracted much attention. This display occupied the entire

company recently made of fifteen large motor trucks loaded with Edison Disc phonographs, featuring the arrival of an entire carload of Edison goods.

The business of this company has shown a

E. P. H. ALLEN WITH EDISON STAFF.

E. P. Huyler Allen has recently been added to the sales force of the Thomas A. Edison, Inc. Mr. Allen's association in the musical business has been of such an extensive nature that he is well qualified to fill the position he now holds. He is the former general sales manager of the Keen-O-Phone Co., of Philadelphia. Mr. Allen has been connected with



Display of Edison Disc Phonographs in Show Window of Barker Bros.' Store, Los Angeles, Cal.

space of two of the largest show windows with a main frontage of 28 feet, and an additional frontage of 24 feet facing the main entrance to the store on one side, and the entrance to the talking machine department on the other. It was a splendid follow-up to the impressive parade which this

phenomenal growth under the management of J. W. Boothe, who has shown marked ability in its handling. From present indications a heavy Christmas trade is anticipated.

Barker Bros. handle the Victor, Edison and Columbia lines including both machines and records.

piano concerns for a number of years—namely, the Aeolian Co., Lauter Piano Co. and Schubert Piano Co. Mr. Allen's success with the new Edison diamond disc has already been very marked, and he is greatly encouraged with the reception that the Edison disc is being given by the trade.

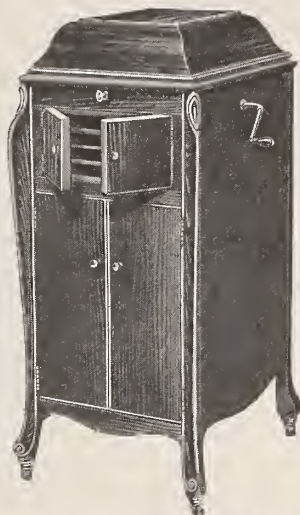

Victrola XI, \$100
Mahogany or oak

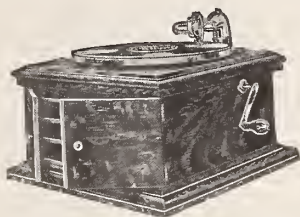

Victrola VI, \$25
Oak

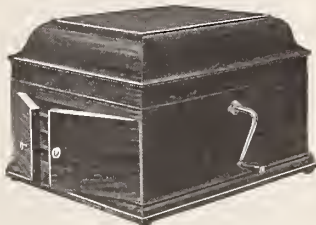

Victrola IX, \$50
Mahogany or oak



Victrola XVI, \$200
Mahogany or oak

“Will there be a Victrola in your home this Christmas?”

That is the question being put before the entire country in the extensive Victor advertising.

That is the question which is going to be settled in thousands of homes—and settled to your satisfaction.

That is the question which will help to make a new high record for Victor Christmas business.

So don't lose sight of the value to you of the Victor holiday advertising and “Will there be a Victrola in your home this Christmas?”

Victor Talking Machine Co., Camden, N. J., U. S. A.

Berliner Gramophone Co., Montreal, Canadian Distributors.

Always use Victor Machines with Victor Records and Victor Needles—the combination. There is no other way to get the unequalled Victor tone.



Victor Distributors

- | | | |
|--|---|---|
| Albany, N. Y. Finch & Hahn. | Detroit, Mich. Grinnell Bros. | Omaha, Neb. Nebraska Cycle Co. |
| Altoona, Pa. W. F. Frederick Piano Co. | Elmira, N. Y. Elmira Arms Co. | A. Hospe Company. |
| Atlanta, Ga. Elyea-Austell Co. | El Paso, Tex. W. G. Walz Co. | Peoria, Ill. Putnam-Page Co., Inc. |
| Phillips & Crew Co. | Galveston, Tex. Thos. Goggan & Bro | Philadelphia, Pa. Louis Buehn. |
| Austin, Tex. The Talking Machine Co., of Texas. | Honolulu, T. H. Bergstrom Music Co., Ltd. | C. J. Hepe & Son. |
| Baltimore, Md. Cohen & Hughes, Inc. | Indianapolis, Ind. Stewart Talking Machine Co. | Penn. Phonograph Co., Inc. |
| E. F. Droop & Sons' Co. | Jacksonville, Fla. Florida Talking Machine Co. | The Talking Machine Co. |
| H. R. Eisebrandt Sons. | Kansas City, Mo. J. W. Jenkins Sons Music Co. | H. A. Weymann & Son, Inc. |
| Bangor, Me. Andrews Music House Co. | Schmelzer Arms Co. | Pittsburgh, Pa. C. C. Mellor Co., Ltd. |
| Birmingham, Ala. Talking Machine Co. | Lincoln, Neb. Ross P. Curtice Co. | Standard Talking Machine Co. |
| Boston, Mass. Oliver Ditson Co. | Little Rock, Ark. O. K. Houck Piano Co. | Portland, Me. Cressey & Allen, Inc. |
| The Eastern Talking Machine Co. | Los Angeles, Cal. Sherman, Clay & Co. | Portland, Ore. Sherman, Clay & Co. |
| M. Steinert & Sons Co. | Louisville, Ky. Montenegro-Riehm Music Co. | Richmond, Va. The Corley Co., Inc. |
| Brooklyn, N. Y. American Talking Machine Co. | Memphis, Tenn. O. K. Houck Piano Co. | W. D. Moses & Co. |
| Buffalo, N. Y. W. D. Andrews. | Milwaukee, Wis. Badger Talking Machine Co. | Rochester, N. Y. E. J. Chapman. |
| Neal, Clark & Neal Co. | Mobile, Ala. Wm. H. Reynolds. | The Talking Machine Co. |
| Burlington, Vt. American Phonograph Co. | Montreal, Can. Berliner Gramophone Co., Ltd. | Salt Lake City, U. Consolidated Music Co. |
| Butte, Mont. Orton Brothers. | Nashville, Tenn. O. K. Houck Piano Co. | San Antonio, Tex. Thos. Goggan & Bros. |
| Chicago, Ill. Lyon & Healy. | Newark, N. J. Price Talking Machine Co. | San Francisco, Cal. Sherman, Clay & Co. |
| The Talking Machine Co. | New Haven, Conn. Henry Horton. | Savannah, Ga. Phillips & Crew Co. |
| The Rudolph Wurlitzer Co. | New Orleans, La. Philip Werlein, Ltd. | Seattle, Wash. Sherman, Clay & Co. |
| Cincinnati, O. The Rudolph Wurlitzer Co. | New York, N. Y. Blackman Talking Machine Co. | Sioux Falls, S. D. Talking Machine Exchange. |
| Cleveland, O. The W. H. Buescher & Sons Co. | Emanuel Blout. | Spokane, Wash. Sherman, Clay & Co. |
| The Collister & Sayle Co. | C. Bruno & Son, Inc. | St. Louis, Mo. Koerber-Brenner Music Co. |
| The Eclipse Musical Co. | I. Davega, Jr., Inc. | St. Paul, Minn. W. J. Dyer & Bro. |
| Columbus, O. Perry B. Whitsit Co. | S. B. Davega Co. | Syracuse, N. Y. W. D. Andrews Co. |
| Dallas, Tex. Sanger Bros. | Chas. H. Ditson & Co. | Toledo, O. The Whitney & Currier Co. |
| Denver, Colo. The Hext Music Co. | Landay Brothers, Inc. | Washington, D. C. Robert C. Rogers Co. |
| The Knight-Campbell Music Co. | New York Talking Machine Co. | E. F. Droop & Sons. |
| Des Moines, Ia. Chase & West Talking Mach. Co. | Ormes, Inc. | |
| Mickel Bros. Co. | Silas E. Pearsall Co. | |
| | Benj. Swirky. | |



We have set just one limit on the Columbia program for 1915—a minimum limit of 100% increase of Columbia record business. Watch it! But watch it from the inside.



(Write for "Music Money," a book "full of meat" for those dealers interested in quick and frequent turnover of capital.)

**Columbia Graphophone Company
Woolworth Building, New York**

NO LULL IN PITTSBURGH TRADE.

Talking Machine Dealers of That City Have About All They Can Do to Meet Holiday Demands—Some Attractive Christmas Displays—What Various Houses Report.

(Special to The Talking Machine World.)

PITTSBURGH, PA., December 11.—The talking machine outlook is the source of much satisfaction to Pittsburgh dealers, many of whom are experiencing a period of the greatest activity in their history. While the piano trade has fluctuated greatly during the past few months, the talking machine business has shown a marked and uniform increase, reaching its climax in the present holiday season. This growth is explained as one result of existing industrial and financial conditions, which have caused a greater number of people to defer the purchase of a piano and seek instead a high-grade talking machine at a much lower investment.

All of the stores were early in taking on a Christmas season appearance, and some of the best effects yet secured in window displays are now in evidence. The S. Hamilton Co. has a striking "Made in America" exhibit. It contains the De Luxe Grafonola, labeled "Made in Bridgeport, Conn."; a Style XVI Victrola, labeled "Made in Camden, N. J."; and an Edison diamond disc, labeled "Made in Orange, N. J." Attractively arranged with American flags and the usual Christmas decorations, this exhibit is one of the most timely and appropriate in the city. The Schroeder Piano Co. shows to excellent advantage the new 1915 model Grafonola, while the Henry Co.'s window is attracting considerable attention with a disc record display, having as its theme, "It's a Long, Long Way to Tipperary."

Manager Norman H. Cook, of the Boggs & Buhl talking machine department, reports business as ex-

ceptionally lively, in both machines and records. Two salesladies have been added during the past week.

The Kaufmann Bros. Victrola department is doing a full capacity business and Manager H. N. Rudderow is exceedingly gratified over the quality and quantity of holiday trade up to the present date. The department's seven demonstration booths are occupied by customers almost continuously. During the past month the sales of records have ranged from 125 to 212 daily.

Although the Lechner & Schoenberger talking machine department has just completed its second month's business, Manager Hartley reports that a very substantial trade has already been established. The new department, which has been made one of

the most attractive in the city, has come in for a large share of the fine holiday trade. Manager Hartley expresses great faith in both of his lines, the Edison and the Columbia, and is very enthusiastic over the future of the newly established business.

The Schoen Music Co. reports that the outlook for its talking machine department is exceedingly bright since the recent removal of the establishment from the Northside to 620 Penn avenue, in the center of the most active business section. Beside the Columbia line, the company is now successfully featuring the Reginaphone. Some excellent sales of this instrument are expected during the next two weeks, in time for delivery before Christmas.

MAKING PERFECT RECORDS.

Some of the Essentials Necessary Discussed by Redferne Hollingshead Who Has Had Much Successful Experience in Making Talking Machine Records.

Redferne Hollingshead, who has made some exceptionally good records for Thomas A. Edison, Inc., contributes to the Canadian Journal of Music his experiences in having his voice recorded. He says:

"I have found that several essentials are imperative to the singing of perfect records. In the first place, the production of tone of the singer must be free and open, absolutely devoid of throatiness. The forward nasal resonance, diaphragmatic breathing, flawless diction—all these are absolutely necessary. A flaw that will pass unnoticed in concert becomes intolerable after its nth repetition in the same place in the machine. The successful singer of rec-

ords must also remember that personality, or stage presence, which is so often such a big factor in the success of concert singers, is here not at all in evidence. The singer must depend on artistry of the very highest type. He must be sure his tone is brilliant, resonant, and withal, sympathetic.

"To insure this his breathing must be well sustained and diaphragmatic. He must, in a word, use intelligence and expression far more faithful, if possible, than when he appears in public. With all these essentials, I see no reason why our concert singers should not find record making as pleasant and satisfying work as concert singing.

"In conclusion, I might say that if there is one vowel which should be avoided by the singer who would make a successful record it is the 'e' vowel, sung tightly on the teeth so as to produce a hard, piercing tone. If the singer will use the French 'e' or 'eh' instead, he will gain invariable success; provided, of course, he follows the dictates of 'Bel Canto.'"

DITSON *Victor* SERVICE

WE know every condition involving all Victor retail sales and we know that having the goods is an important factor towards getting the big profits. For your benefit, we maintain the largest stock in the East of Victor machines, records and supplies, and you can feel sure that your orders receive quick attention. The Ditson organization is trained to render the leading service and you can link up your store to our warehouse and feel safe.

Ask us to explain the value of Ditson co-operation. It means much to your business.

OLIVER DITSON CO., Boston, Mass.

TRADE CONDITIONS IN CINCINNATI.

Ten Cent and Post Card Records Appear to Worry the Regular Dealers—General Business Very Satisfactory—John Shillito Co. Opens New Department—Dealers Well Stocked with Goods—News of the Month.

(Special to The Talking Machine World.)

CINCINNATI, O., December 8.—Local retailers have another cause for complaint. Consumers during the past few weeks have been able to pick up records suitable for use on the Victrola and the Columbia instruments for 10 cents a throw. And it seemed that the news spread like leaves before a storm, for a tremendous sale of the cheap article has taken place.

"Little Wonders" is the name of the record which is being sold at a five and ten-cent store, and while not a well finished article, the cheapness and the novelty of the plates have resulted in an unusual sale.

Then, too, some owners of machines, having friends in Germany, are talking about a postal card record, some of which have reached this city. They cost 10 cents and this novelty, when once properly introduced, will also have quite a run here.

The Victrola line is now domiciled in the music department of the John Shillito Co. The first announcement was made just a week ago. The company, through the Krell Piano Co., was considering such a line for months, and it was a fight between the two prominent houses of the company. The matter of payment of stock is said to have won. The goods are coming into this market from a Chicago house. The entrance of the Shillito concern into this field has caused the H. & S. Pogue Co. to give more publicity to its department. The situation here to-day is that the talking machine is receiving more publicity than pianos.

"Business is not really what it should be, and yet we have left November so far behind that we have about cleaned out our stock," said Mr. Whelen when asked about present conditions. Mr. Whelen, manager of the local Columbia store, further stated that "December is starting in as a close second, and if we can get the goods which we badly need we will make last December results look like thirty cents. The demand is spreading out through the entire territory and while the smaller dealers are crowding in their orders, the larger dealers profited by experiences of former years, when the demand was heavier than the supply and stocked up beforehand. The factory, in order to save time, is shipping direct to the dealers, but even so our shipping facilities are taxed to the limit."

The local "Dictaphone" headquarters at the Columbia store are busy working on new prospective sales, but the dictaphone is holding its own in the busy holiday rush handling correspondence with speed and accuracy in a way that makes its use invaluable to dictaphone users.

S. H. Nichols, who was recently appointed district manager, spent a few very pleasant days in the Cincinnati Columbia store. Mr. Nichols was the former manager of the Cincinnati store preceding Mr. Whelen, the present manager, and it was like "old times" to have him back, if only for a few days.

SUITABLE NEWLY-WED RECORDS.

Hearts and flowers, Roses, roses everywhere,
The Bells, O promise me, For all eternity,
A perfect day, In the evening by the moonlight,
Dear Louise, You're just too sweet to live.
Silent night, Sweet spirits hear my prayer,
Ah so pure, You've got to get under, Get out
and get under, Love me and the world is mine.
Scenes that are brightest, A dream, Every little
movement, Below the Mason-Dixon line.
Draw me nearer, Close to thee, In happy moments.
Beautiful isle of somewhere, Happy days, Call me
your darling again, Where the Robins nest again,
We have much to be thankful for, Some day, There'll
come a day, Afterwards, And a little child shall
lead them, Baby Rose, When it's apple blossom time
in Normandy, Old Folks at home, Where the morning glories
twine around the door, Bake that chicken
pie, Good-bye sweet day, Home, sweet home.

PROSPERITY REIGNS IN CLEVELAND.

Both Wholesale and Retail Stores Very Busy—Many New Dealers for the Leading Lines May Break Last Year's Holiday Record.

(Special to The Talking Machine World.)

CLEVELAND, O., December 7.—The activity manifest in the wholesale and distributing talking machine stores is reflected in the very prosperous business in all the Cleveland retail establishments.

Increasing sales, of both Victrolas and records, is impelling the business to much larger than the normal volume of the Eclipse Musical Co. Demand for Victor goods from local dealers, and from all sections in this territory, are reported good, and indicates, Mr. Towell says, a large holiday trade.

G. R. Madson, manager of the Columbia store, reports the sales of Grafonolas and records as very satisfactory, largely of the higher grade instru-

ments. The Columbia dealers are all doing fine business.

The Edison distributors for this territory, the Phonograph Co., is daily increasing its sales and extending its business throughout this section. Mr. Bloom, of the company, is highly pleased with the present and prospective business.

The Collister & Sayle Co.'s sales indicate a large increase in the wholesale department. Mr. Dorn says the holiday trade will prove as satisfactory as usual.

At the exclusive wholesale and distributing Victor store of the W. H. Buescher & Sons Co., on Chestnut street (entirely separate and distinct from its retail store), a good and growing business is reported. The store is larger, suitably fitted up, and carries a larger stock of Victor goods.

In a line-up of the retail trade, indications are that this season's holiday business will exceed that of last year.

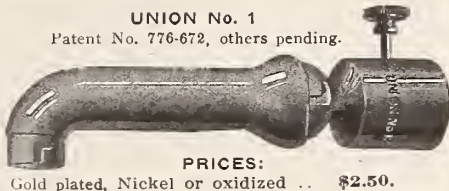

UNION No. 1
Patent No. 776-672, others pending.

PRICES:
Gold plated, Nickel or oxidized .. \$2.50.

4 Easy Sellers—



UNION MODIFIER
Pat. Pend.

PRICE.
Gold plated, nickel or oxidized...\$1.00

THE upper illustration shows UNION No. 1, for playing Columbia and Victor records on Edison Machines. UNION No. 1 contains the UNION Modifier feature. The second illustration shows the UNION Modifier, a quick-selling device, giving Edison, Victor and Columbia owners absolute control over the volume of sound.

UNION TALKING MACHINE SPECIALTIES

AT the right is the new UNION Sound Box, just out, taking Fibre or any make of needle. It is the latest improvement in sound reproduction, and fits all Disc Machines. Ask for quantity prices.

UNION SOUND BOX



PRICES:
\$4.00.
Gold plated, Nickel, or oxidized.

The UNION Needle Box shown below fills another long-felt want.

Write to-day for descriptive folders and prices on these six easy-selling specialties.

All persons selling goods infringing our patents are liable to suit for such infringement.

LIST PRICES SHOWN HERE

UNION NEEDLE BOX for Edison Machine.

USUAL DISCOUNT TO DEALERS



PRICE:
Finished in Mahogany, Circasian Walnut or Fumed Oak, any finish, 50c.



Increase Your Sales

HERE are two quick-selling specialties that appeal to your customers:

UNION TALKING MACHINE SPECIALTIES

UNION No. 2 (upper illustration) plays Edison Records on Victor Machines. No alteration is necessary. Price, gold-plated \$9.00, nickel, \$8.00, with Diamond Point.

UNION No. 3 (lower illustration) plays Edison Records on Columbia Machines without altering machine in any way. Price, gold-plated \$9.00, nickel \$8.00, with Diamond Point. Sapphire Point, \$1.50 less.

Liberal discount to jobbers and dealers

Our tone arms and sound boxes are the best on the market.

ASK FOR QUANTITY PRICES



The TALKING MACHINE WORLD

For the makers & sellers of talking machines

EDWARD LYMAN BILL, - - - Editor and Proprietor.

J. B. SPILLANE, Managing Editor.

Trade Representatives: GLAD. HENDERSON, C. CHACE, L. E. BOWERS, B. BRITAIN WILSON, A. J. NICKLIN, AUGUST J. TIMPE, L. M. ROBINSON.

Boston: JOHN H. WILSON, 324 Washington Street.
 Chicago Office: E. P. VAN HARLINGEN, Consumers' Building, 220 South State Street.
 HENRY S. KINGWILL, Associate. Telephone, Wabash 5774.
 London, Eng., Office: 2 Gresham Buildings, Basinghall St. W. LIONEL STURDY, Manager.
 Representatives for Germany and Austria: VERLAG NEC SINI, Berlin C. 19, Ross-Strasse 6, Germany. GEO. ROTHGIESER, Director.
 The Talking Machine World has regular correspondents located in all of the principal cities throughout America.

Published the 15th of every month at 373 Fourth Ave., New York.

SUBSCRIPTION (including postage), United States, Mexico, \$1.00 per Year; Canada, \$1.25; all other countries, \$1.75.

ADVERTISEMENTS: \$3.50 per inch, single column, per insertion. On quarterly or yearly contracts a special discount is allowed. Advertising pages, \$120.00.

REMITTANCES: should be made payable to Edward Lyman Bill by check or Post Office Money Order.

NOTICE TO ADVERTISERS.—Advertising copy should reach this office by the first of each month. By following this rule clients will greatly facilitate work at the publication headquarters.

Long Distance Telephones—Numbers 5982-5983 Madison Sq.
 Cable Address: "Elbill," New York.

NEW YORK, DECEMBER 15, 1914.

ANOTHER Christmas is almost here with all its influences, which tend to soften and to expand mankind along gentler lines!

The Christmas spirit is a buying spirit—a softening spirit—a spirit which tends to cause happiness everywhere, and talking machine men have reason to feel reasonably happy for the measure of prosperity which they have enjoyed during the present year.

It naturally follows that the cruel war which is devastating Europe must affect the people in all lands, and many business enterprises in America have been frightfully curtailed in output by reason of existing conditions in Europe. But the talking machine trade has been singularly blessed. It has shown an increase in the manufacturing output, for the records of 1914 will show the most fruitful year which the talking machine industry has ever enjoyed. Talking machine dealers have also had their full share of prosperity, and when we compare the conditions existing in the manufacturing and retailing departments of this industry with those which exist in other lines, it must be conceded that we have much for which we should be thankful.

EVERY phase of the talking machine industry has shown a distinct advance over previous years. From the financial stability of the trade down to the development of the best selling ability of the retail salesman there is a better feeling existing to-day.

Men are perhaps in closer touch with their business than ever before. They understand it better—realize its possibilities, and it must be conceded that the most important problems of the trade, such as quality of product—perfection of advertising, and other similar phases of the industry—have received careful attention this year. And, judging from indications, the thought and consideration given these problems have produced results commensurate with the outlay.

There is certainly an element of progressiveness infused into the work of talking machine men which is distinctly noticeable, and while complaints regarding general business conditions have been frequent and widespread, and there has been a material shrinkage, the talking machine trade has stood up under storm and stress, and has come out victorious. That fact in itself should prove inspiring, and the men who accomplish real success are those who have confidence in the business, in which they are engaged and confidence in the business conditions of the country. Without doubt the few remaining days of the year will be used by talking machine men to excellent advantage, and there will be a good many holiday sales yet closed which will help out materially the business of the year.

THE musical standing of the talking machine has received a greater impetus during the past year than ever before. It has become a greater force in the musical life of the nation, and as an educational factor and as an aid in the school room it is steadily acquiring greater power.

Record music is making America more and more musical every day. In fact, it is contributing more to the musical entertainment of our people than any other single element. In the schools in every city throughout the land pupils to-day in folk dancing and calisthenics step to the measures of record music. Classes march from the building or to the assembly hall to the tune of stirring marches. Music lessons are conducted with the children listening to records, and studying the printed pages of music at the same time from their school books. The regular grade teacher is being assisted in her literature work. Analyses of songs, with vocal illustrations, teach enunciation, phrasing and expression. Analysis of the modern symphony orchestra, with the children learning the individual tone qualities of each instrument, serious study of opera, librettos and scores, all testify to the truth of the statement that records are a necessity.

The result of this is far-reaching. It is compelling dealers and salesmen to become acquainted with musical literature, with the operas, and to become acquainted with the record stock, and it is all working out to higher and better things.

FROM a commercial viewpoint the talking machine is moving steadily ahead, and the advertising end of the business has more than kept pace with the rapid strides in publicity made by the talking machine product of the past year.

The advertising of the talking machine manufacturers is generally commended by advertising experts as symbolic of the very highest type of modern publicity, and in view of the constant, forceful and impressive national and newspaper advertising carried on by the manufacturers, it is not to be wondered at that the sales of talking machine records during 1914 have reached the high water mark, notwithstanding the serious shock which general business has received through the European war.

Business methods—plans—systems—have improved. The small dealers are beginning to learn that selling talking machines is a business, and they have been aided by the manufacturers and jobbers, who have given them valuable personal co-operation. In fact, the talking machine industry is composed to-day of an energetic body of men who represent modern business progressiveness, and their advance is certain and sure.

NOW and then clouds appear upon the trade horizon, but these are quickly dispelled. The business has stood up splendidly under the attacks which have been made upon it. Dealers of standing appreciate more and more that price maintenance means business stability, and that the manufacturer, who has spent time and money to create a demand for his products, does not seek a special privilege when he makes contracts to prevent retailers from slashing prices which are known to be fair.

Price maintenance is a trade principle in which every talking machine dealer should be interested, for price maintenance means that uncertainty and haggling are eliminated, likewise unjust discrimination among customers.

It likewise guarantees to the purchaser a standard of quality, and when you come to analyze it, what other way is there in which a full standard of value can be secured everywhere in the retail world than through a uniform selling price?

As it stands to-day in many trades, the transaction of buying and selling is a contest of wits. The seller gives in many instances as little value and gets as much money as he can. Within ample limits the seller might legally lie with impunity, and, almost without limits, he might legally destroy, by silence, a really good bargain. But that condition is wrong, because it creates a widespread system of cut-throat prices which in the end does not deceive anyone. When one price is established by the manufacturer, the unscrupulous merchant is forced to abandon his plan of the substitution of cheap and inferior products for the standard articles.

THE practice of price-cutting on standardized articles would mean ultimately depreciating a name to an alarming extent which had become fixed in the public mind as a standard.

What is price-cutting for? It is simply a baiting to attract persons to the store by giving the idea that it is enabled to give lower prices than others, and to prove it, puts forth a standardized article at a cut rate. That is the department store plan, and the business of many department stores has been built up by price baiting, and it seems but a logical sequence that department stores should be anxious to offer, provided, the law would not prevent them, standard talking machines at cut rates, because that would cultivate the idea that readers of the advertisement would be impressed with the ability of the department store to supply cut rates on other lines of merchandise than those advertised.

The talking machine trade should oppose strongly any attempt at price-cutting by men who have not the welfare of the trade at heart.

Furthermore, if it were possible to engage in price-cutting on standardized machines generally, it would depreciate the business and the profits of every man selling talking machines. It would in a little while demoralize the business to such an extent that the regularity of the business would be destroyed. Its profits would become lessened and its stability weakened. There is no other end ultimately to the price-cutting of a standardized article.

We believe that price maintenance is the foundation upon which the security of this industry rests. Shatter the foundation and the edifice crumbles.

This thought should be impressed upon the minds of every reader of The World, because we are all vitally interested in seeing the direction along consistent lines, so that the trade and the public are amply protected in every way.

SO far as we know never in the history of commercial advertising has there been such supplementary work as has been put forth by the Victor Talking Machine Co. in its recent holiday campaign for dealers in the cities of New York and Chicago. Full page advertisements have appeared in all of the dailies of these cities, not merely once, but in some instances a number of times, containing the names and addresses of Victor dealers within the metropolitan zones indicated.

These pages and others which immediately followed were

gotten up in a most attractive manner with portraits of the world's leading artists who sing for the Victor, thus combining the artistic side and suggesting the talking machine as a holiday gift.

This is really the finale of the national campaign of the Victor Co., the crux of which has been, "Will There Be a Victrola in Your Home This Christmas?"

WHEN the great Edison plant, covering almost a square mile of ground at Orange, N. J., was a mass of flames on the fateful night of December 9, Thomas A. Edison stood nearby and saw the work of years wiped out by the devastating flames.

The famous inventor has been termed the greatest living American, and his greatness was never evidenced in a more striking manner than at this critical time. When the leading men of his town were crowding about him, expressing their sympathy, he said with cheerful voice: "I'll start all over to-morrow. There will be some rapid mobilizing here when this débris cools off and is cleared away. I'll go right to work to build the plant over again. It is just a temporary setback; don't forget that."

There is revealed a will power—a spirit which never downs—and Thomas A. Edison and his business associates have lost no time in perfecting plans for a newer and greater Edison plant. Fire and destruction can only temporarily halt the onward march of such an indomitable will.

The entire sympathy of the trade will be enlisted in behalf of the company which has suffered so greatly, and that sympathy can be expressed in no better way than in putting up with unavoidable delays and inconveniences until the time arrives when the Edison Co. can complete its plans for regular output of stock.

It seems particularly unfortunate, just at this time, when the plant was rushed with holiday orders, that such a terrible calamity should occur, but the Edison enterprise is composed of men who will speedily work out of the present distressing conditions and will, ere long, be able to supply the needs of the Edison representatives.

Depend upon it all that can be, will be done.

EDISON DISC and CYLINDER PHONOGRAPHS EXCLUSIVELY

Dealers of New York and New Jersey

We can assure you prompt and efficient service and deliveries by reason of our being the nearest distributors to the Edison factory, and therefore in a position to keep our stocks complete and up-to-date at all times.

Eclipse Phonograph Company

A. W. TOENNIES & SON
Edison Distributors

203 Washington St.

Hoboken, N. J.



A200



A150



A250

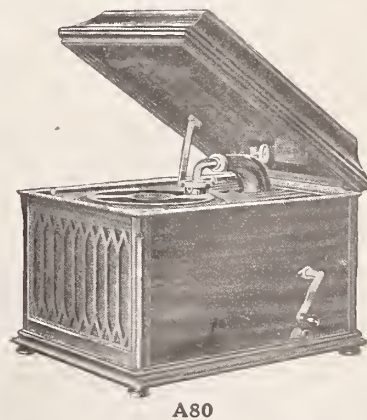

A80

DEALERS, ATTENTION!

We are showing an attachment that we manufacture to go on the Edison Talking Machine which enables one, with the aid of a Pathé Soundbox, to play the wonderful Pathé Discs and puts the unlimited Pathé repertoire at everybody's disposal.

SEND US \$1.75 FOR A SAMPLE ATTACHMENT,
or else mail your order for a dozen at \$18.

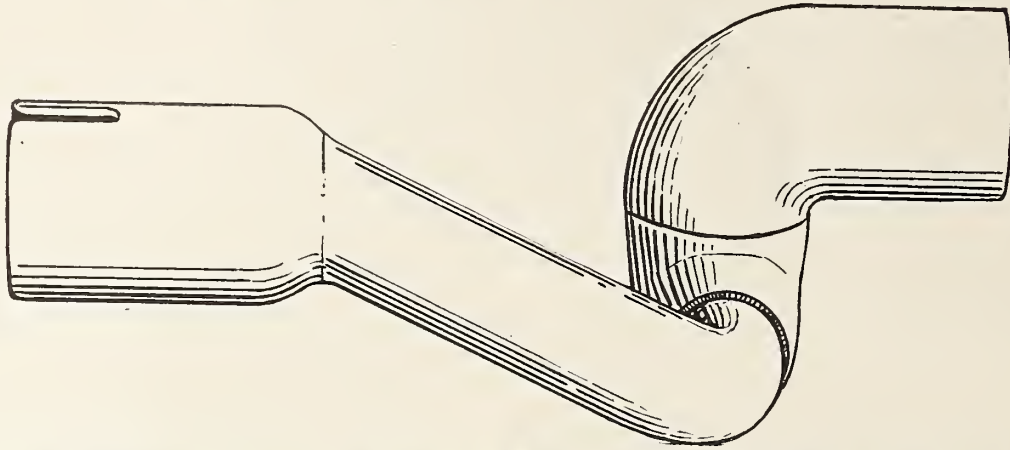

BETTER REPRODUCTION!

In our opinion, by means of our attachment, you can get as perfect a reproduction on the Edison machines of Pathé Discs as you can on the Pathé machine itself.

This gives you the widest choice among the Pathé records, with their incomparable fine Band and their low-price Operatic discs.

F. C. KENT CO., 81 Columbia Avenue, Newark, N. J.

A NEW IDEA

Attachments for Edison Machines

We now place before you the opportunity to please the taste and supply every whim of your customers by means of our attachments to be used on the Edison disc machines with the Pathé Sound Box. This gives you an entrée into the vast repertoire of the Pathé disc records.

YOU CAN PLAY PATHÉ DISCS ON THE EDISON MACHINES

in this way better than Pathé can play them on their own instruments. You can now have the finest operatic or the most popular selections in your place.

THE LAST WORD IN ATTACHMENTS—We have perfected an attachment to be used on the Victor and Columbia machines to play both the Edison and Pathé records perfectly.

—PRICE—

Sample attachment with sapphire for Victor and Columbia machines	- \$3.00 each, net
Sample Edison attachment	- \$2.00 each, net
Sample Diamond Point for Edison attachment	- \$3.00 each, net
Edison attachment with sapphire to play Pathé Record	- \$2.50 net

THE UNION SPECIALTY & PLATING CO.

409 Prospect Ave., N. W. Cleveland, Ohio

Pathé Frères Phonograph Co.

Cable Address:
Pathephone, New York
Telephones 1980 Greeley

29-31-33 West 38th St.

Pathephone
Pathegraph
Pathe Discs

New York, December 12, 1914

TO TALKING MACHINE DEALERS

Gentlemen:

Pathé Frères goods have been on the market several months, have been well received, and have had unbiased complimentary judgment passed on them. A number of dealers have been established, but we are ready for more. We will give exclusive agencies and liberal territories to the right parties and make it worth their while to handle our goods.

Whether a man sells competing phonographs or not is of no interest to us. Pathé Frères goods sell on their own merits and will sell in competition with the best.

Our records can be played on other machines. The attachments that are now being made are cheap and simple.

Pathé Frères Operatic records range from \$2.00 to \$2.50 and are double faced. We would recommend that you send for record #X2058, "Celeste Aida" on one side and "Song of Triumph" from "The Prophet" on the other, sung by Leo Slezak, the world's most famous German tenor, or #X2016, "La Boheme" on one side and "The Girl of the Golden West" on the other side, sung by Giorgini, of the Metropolitan Opera House, New York; Covent Garden, London; and La Scala, Italy, who toured the United States last year with Tetrzzini and Titta Ruffo.

For Band records try our #2151, "American Parade" on one side and "Le Cimbre" on the other side, or ask for our catalog and select anything from it. We will send you any record with our compliments, upon request.

Be successful by being up-to-the-minute.

Yours very truly,

PATHE FRERES PHONOGRAPH CO.

THE TRADE IN BOSTON AND NEW ENGLAND

JOHN H. WILSON, MANAGER, 324 WASHINGTON STREET, BOSTON, MASS.

(Special to The Talking Machine World.)

BOSTON, MASS., December 9.—Despite the fact that many lines of business are more or less hard hit by the present conditions, it is a fact that almost every talking machine dealer in the city and environs, as well as many of them through New England, are going to show a surprisingly good business. Some localities are to do better than others. For instance, outside of Boston such cities as Lowell, Lawrence, Fall River and New Bedford, cotton industrial centers, where business is booming owing to war orders, dealers are making most encouraging reports. On the other hand, there are other cities whose industries are not profiting by the war where it is very hard to get business, and where, too, collections are slow for those concerns which sell on time payments.

The war tax stamps are playing their part in the sending of talking machine goods, and the rush for stamps by all the Boston houses was so great on the first days of the month that the Federal authorities found it difficult to satisfy the demand. Where possible the local stores have laid in a large supply, but this is true in only a few cases. Inasmuch as the parcels post system is exempt from the stamp tax the new arrangement is going to largely increase the business by these carriers, and even in these few days the parcels post system has been taken advantage of by some houses to an extent hitherto unknown.

Increases Sales Space.

Harry Rosen, whose store in School street is one of the most conveniently located ones downtown, has seen his business grow so that he has been forced to add to his suite of rooms, and carpenters are now at work tearing out partitions and making a general rearrangement by which Mr. Rosen will have quarters more than twice as large as those he now has. Also on the floor above he has several other rooms and into these he has moved his Edison department. The repair room, stock room and other departments will be installed there. Three new men which Mr. Rosen has taken on are A. W. Butterman, Harry A. Brigham and Mr. Haskell, formerly with the Columbia people.

Distinguished Visitors.

Edward D. Easton, president of the Columbia Graphophone Co., and George W. Lyle, the vice-president of the same concern were in town for a couple of days lately and they went over the local situation carefully with Manager Erisman. As it was their first visit here since the new Co-

lumbia store was made over they were deeply interested in all the details, and they expressed themselves as more than satisfied at the enlarged facilities for handling the large business. Since their visit the local business has grown even larger and within the past few days it has exceeded all bounds. Naturally, Manager Erisman is highly pleased over the outlook for the month of December.

Cleverly Arranged Victor Window.

Passers-by on Arch street in the downtown section of the city have been interested in the clever arrangement of the window of the M. Steinert & Sons establishment in that street. It was Manager Royer's idea that a fox would prove a drawing card by way of advertising the fox trots, several of which are among the Victor numbers. So he got a fine specimen of the stuffed variety and placed it in the window. On one side is a Victor machine and on the other a large card showing a couple dancing a fox trot, and to both of these the fox is attached by means of ribbons. Hanging to the fox's neck is the placard, "O, You Fox!" Manager Royer has heard lots of commendatory remarks for the enterprising scheme as a medium of advertising.

Pardee-Ellenberger Co. Activity.

Manager Silliman, of the Pardee-Ellenberger Co., Inc., reports business booming all along the line, which is to say that the Edison diamond disc business throughout his territory has reached very large dimensions. Mr. Silliman says that the only difficulty now being experienced is in getting the machines fast enough to supply the demand. Mr. Silliman and his son, Horace, were among those who went down to New Haven for the great game between Harvard and Yale.

More Artistic Window Arrangement.

The Boylston street windows of the M. Steinert & Sons Co. have been done over so as to admit of a more artistic arrangement. A high paneling of French gray and white now separates the windows from the rest of the store, and built high the paneling serves as a capital background of the Victor outfits. Just at this time the windows are hung with Christmas greens and the large wreaths of laurel tied with red ribbons lend quite a festive appearance to the Victor display.

Callers on the Eastern Talking Machine Co.

Arthur Fields, who wrote "Aba Daba Honey-moon" and who has just been appearing at Keith's Theater, has been a caller at the Eastern Talking

Machine Co.'s Boston headquarters. Another caller was Joseph Santley, who also has just been a Keith attraction. None of the star performers who appear at this handsome vaudeville house, which is only a block away, if they make records for the Victor ever miss an opportunity of calling on Manager Taft and the Eastern boys.

Visited New York Headquarters.

Manager Arthur Erisman, of the Columbia Co., was over in New York a short time ago conferring with some of the company's officers. Mr. Erisman has lately had a post card prepared by way of booming the foreign record department of his business and on one side is a list of the twenty languages records of which can be found in the department devoted to this line.

Reports an Excellent Business.

All the staff of George Lincoln Parker's Victor and Edison departments in the Colonial building are glad to again welcome John Alsen, who has been away seriously ill for several weeks. Mr. Alsen has many friends in the Boston trade who, too, are glad he is able to get back to work. Mr. Parker states that his November business in the Edison and Victor lines has been most satisfactory, and the prospects are good for a large December business judging by the way it has begun.

Developing the School Proposition.

Mrs. Henrietta Heaton, of the educational department of the Eastern Talking Machine Co., has been in the city for two weeks, making a survey of the school proposition. She gave a number of talks while here and visited any number of the more prominent educational institutions.

Noted Record Artists Visit Boston.

Harry Lauder, the great Scotch comedian, who has just finished a big engagement at the Shubert Theater, and John McCormack, the Irish tenor, who gave a recital at Symphony Hall, were visitors at the Eastern Talking Machine Co.'s local warehouses. In honor of their presence in this city, the Tremont street windows of the Eastern made an appropriate display of their records, one being confined to Lauder and the other to McCormack.

Scoring Splendid Success.

Thanks to business ability and a good personality, Mrs. Anna Jones has been making a splendid success of the talking machine department of the Shepard Norwell Co. in Winter street. Mrs. Jones has been with the department ever since it was opened about three years ago on the third floor of the Temple place side of the building.

PARDEE-ELLENBERGER CO., Inc.

BOSTON, MASS. NEW HAVEN, CONN.

The demand for Edison Diamond Disc Phonographs continues to grow by leaps and bounds. Our New England Dealers are becoming more enthusiastic over this wonderful line from day to day. One of our Dealers, in a small city, has just made the statement that he would not take five thousand dollars for his agency. If you will investigate the proposition, you will readily see why there is such a demand for this musical instrument.

We would be glad to interest you in an agency proposition in places not already thoroughly covered. We will co-operate with you towards making your department a success, and you will soon build a business that will be very profitable. The highest grade line of musical instruments and a weekly service on new records.

Don't neglect this opportunity.

Real Music
At Last

EDISON DIAMOND-DISC PHONOGRAPHS

THE TRADE IN BOSTON AND NEW ENGLAND

JOHN H. WILSON, MANAGER, 324 WASHINGTON STREET, BOSTON, MASS.

and in that time the department has been enlarged several times. Mrs. Jones possesses a thorough knowledge of the talking machine business and in these three years she has been instrumental in selling a great many Victor and Columbia outfits.

Talking Men Get Together.

Several inquiries have been made lately as to when the boys of the talking machine business are again going to get together. The beefsteak dinner of three years ago is pleasantly recalled by many, and there are lots of good fellows who'd be glad to enter into the spirit of another such time. Who'll volunteer to engineer it?

H. A. Yerkes a Visitor.

H. A. Yerkes, the wholesale manager of the Columbia Co., was a Boston visitor within the past week. He was entertained by Manager Erisman.

ENTERTAINS IMMIGRANTS.

Eastern Talking Machine Co. Sends Victrola to Immigration Station in Boston to Furnish Music for Thanksgiving Day—Thoughtfulness Much Appreciated.

(Special to The Talking Machine World.)

BOSTON, MASS., December 9.—The Eastern Talking Machine Co. at 177 Tremont street, through the instrumentality of William J. Fitzgerald, the manager of the wholesale department, sent down a Victor outfit to the immigration station the day before Thanksgiving for the benefit of the immigrants who were detained there. The instrument gave the greatest satisfaction and immediately Commissioner H. J. Skeffington sent a letter to Mr. Fitzgerald, which read as follows:

"The undersigned wishes to express our appreciation of your courtesy in loaning for the benefit of the detained immigrants at this station one of your Victor machines, together with a choice selection of records. It was a happy combination of circumstances that brought the machine in time for use on Thanksgiving Day. For while the celebration of this festival in the usual spirit was hardly to be expected in the case of persons involuntarily detained, it should be said that the entertainment provided by your Victor served in some measure to impress upon the immigrants the significance of the day, and greatly added to the enjoyment of the occasion. When the facts were explained to the immigrants assembled they expressed their feelings in a rising vote of thanks, which it is a pleasure at this time to convey to you. Your kindness was not only appreciated by the immigrants, but will be felt by others during the coming months."

WM. H. GREEN APPOINTED MANAGER.

(Special to The Talking Machine World.)

WORCESTER, MASS., December 8.—William H. Green, who has been employed by the Atherton Furniture Co., of this city, has been appointed manager of the talking machine department of this house. This concern handles the Columbia graphophones and the Edison diamond disc outfits, and with both of these the house has been very successful. Mr. Green is starting on a campaign which promises well. The department is well equipped for the display of machines, and two small booths play an important part in demonstrating goods.

BIG PURCHASE OF RECORD ALBUMS.

(Special to The Talking Machine World.)

BOSTON, MASS., December 7.—H. Rosen, of the School street talking machine headquarters, has just made a large purchase of record albums from a Boston stationery house. Mr. Rosen says this is the largest purchase of albums ever made by a Boston dealer. It is his intention to interest the trade in these albums, which are of the standard improved loose-leaf kind, some for the 10-inch and others for the 12-inch records. In a leaflet which Mr. Rosen has put out six reasons are given why this particular holder should be used.

STIMULATING SALES ACTIVITY.

Special Rewards for Sales Force Who Made Largest Records of Sales.

(Special to The Talking Machine World.)

WORCESTER, MASS., December 4.—At the Denholm & McKay Co.'s large store a prize selling contest lately was undertaken which has resulted most encouragingly for all concerned. It was continued from the 10th of one month until the 13th of the next, and the prizes offered were of generous cash amounts and were offered to the clerks of the store in the departments making the greatest gains in percentage over the business of last year for the corresponding period. Out of the fifty-two departments of this big store the talking machine department led with an increase of 170 per cent. This is certainly "going some" for alleged hard times. As one of the men said: "We hustled some to do it, believe me." The manager of the talking machine department at this establishment is William F. Howes, who formerly was manager of a similar department at Houghton & Dutton's, Boston. He assumed his present position last April, and in that time he has made some splendid strides in his department.

NUTTING TO HANDLE "TALKERS."

(Special to The Talking Machine World.)

MANCHESTER, N. H., December 4.—W. L. Nutting, of this city, who has a well-equipped piano store at 4 Temple street, has decided to get into the talking machine game and he has taken on the Edison diamond disc line. Although having it but a short time, he has been able to interest a great many people in the proposition.

BUILDING UP A GOOD BUSINESS.

(Special to The Talking Machine World.)

PORTSMOUTH, N. H., December 6.—Joseph M. Hassett is finding a good business in Victor and Edison goods. The conveniently located establishment at 115 Congress street has had many callers, including some of the best people of the city, within the past few weeks, most of them intent on purchasing for Christmas. Mr. Hassett's business in records alone has been extremely large.

NEW MANAGER IN WORCESTER.

C. H. Schaeffer Takes Charge of Barnard, Sumner & Putnam Co. Department—Other News.

(Special to The Talking Machine World.)

WORCESTER, MASS., December 4.—C. H. Schaeffer has been appointed manager of the talking machine department of the Barnard, Sumner & Putnam Co. Although a comparatively new man to the talking machine business, he has been well coached by W. C. Clifford, who is well-known to the trade. This house carries the Edison diamond disc and Columbia outfits and the holiday business has thus far been excellent.

The Worcester Phonograph Co., of 11 Trumbull square, is meeting with great success with the Edison line, and it has been conducting some well-attended recitals among some of the leading clubs of the city.

The Marcellus Roper Co., of 284 Main street, which is considered the largest Victor dealer in this vicinity, is meeting with marked success, due in no small degree to the work of Daniel J. O'Neil, brother to the well known ambassador, "Doc" O'Neil.

H. R. Skelton, the hustling traveler for Thomas A. Edison, has been in town endeavoring to make the diamond disc outfits a household word throughout the city and environs. He spent two weeks in town and he says that the holiday business in Worcester promises to be large, and that there is likely to be a shortage in high-priced outfits.

KEPT OPEN HOUSE DURING GAME.

(Special to The Talking Machine World.)

NEW HAVEN, CONN., December 8.—The Pardee, Ellenberger Co., Inc., whose large establishment here is known throughout the State, kept open house the day of the big football game between Harvard and Yale. Practically all of the Edison dealers who happened into the city for the day paid their respects to the house and those who had not been there before were delighted to be shown about the establishment. Among those who were entertained by Mr. Pardee and his partner was F. K. Dolbeer and members of his family, and Manager Silliman, of the Boston store, and his son, Horace. After the game several of Mr. Pardee's more intimate friends were entertained at his hospitable home.

If your needles are
made by Bagshaw
—they are made right

We guarantee Bagshaw-made

Needles to be the best
for any record

W. H. BAGSHAW

Established 1870

Oldest and Largest Manufacturer in the World

LOWELL

MASS.

Over 63 million talking machine needles shipped in ten consecutive working days to customers in the United States.

This is the world's record, and shows at a glance the magnitude of our facilities.

HIGHER PRICED MACHINES HAVE CALL IN MILWAUKEE.

One of the Features of a Lively Holiday Trade—Prospects of Big Business Gains Over Last Year—Billings & Sons Piano Co. to Handle Talking Machines—War on Transient Merchants—Shortage of Some Types of Machines Now Reported—New Dealers.

(Special to The Talking Machine World.)

MILWAUKEE, Wis., December 8.—Milwaukee dealers are finding themselves in the midst of an exceptionally busy holiday trade. There was some doubt expressed earlier in the season as to whether or not this year's holiday business in the talking machine field would be quite up to normal, considering the depression experienced in some lines, particularly the iron, steel and heavy machinery business, Milwaukee's most important industry. The developments, however, have been so favorable that there is now every assurance that trade will show a substantial gain over a year ago. Practically all the leading houses experienced a good gain during November and conditions thus far in December have been entirely satisfactory.

There has been one interesting development in the trade thus far this season, and that is the increased demand for high priced machines. This seems to have been due to the fact that so many of the people who usually buy the cheaper machines have been out of work this fall and are finding themselves able to buy only the bare necessities. One would naturally think that the total business would show a falling off, because of the fewer sales of cheaper machines. Dealers and jobbers declare, however, that the sale of high priced goods has more than offset the decline in the demand for the more moderate priced equipment.

Dealers about Wisconsin and other territory tributary to Milwaukee jobbing houses have been buying freely this fall, according to the leading jobbers. Conditions in the smaller cities and towns and about the State in general are very satisfactory. Crops have been good and these are being disposed of at top-notch prices, with the result that there is plenty of money about the State, if people can be induced to part with some of it.

To Open New Department.

The Billings & Sons Piano Co., Milwaukee's latest piano house, which recently opened in its handsome new store in the new Miller building at 504 Grand avenue, is planning on taking up the agency for a well-known line of talking machines. The deal has not been closed at this writing, but it is practically certain that a talking machine agency will be established at the store.

Milwaukee talking machine dealers have been congratulating the piano houses on their success in having an ordinance introduced in the Milwaukee Common Council which aims to curb the operations of transient merchants in all lines of business. Many of the piano houses carry a talking machine line, so the interest has been general. The ordinance, which has been recommended for passage by the judiciary committee of the Council, provides that the transient merchant will have to submit to the city treasurer each morning a statement of his sales of the previous day and pay a fee amounting to 10 per cent. of the sales, the total fee to be paid not to be less than \$5 nor more than \$25.

Shortage of Machines Reported.

The shortage experienced in Victor machines in Milwaukee this fall is becoming a serious matter in some quarters, especially during the holiday season. Jobbers are being besieged by dealers for certain lines of machines, but they in turn are unable to have their orders filled by the Victor factory.

"We could do 400 per cent. more business if we could only secure enough machines from the Victor factory," said H. A. Goldsmith, secretary of the Badger Talking Machine Co., jobber in Wisconsin and Upper Michigan territory for the Victor goods. "The demand from dealers became

stronger this season than anyone anticipated, and we are finding it impossible to satisfy the trade. The shortage is especially felt in styles X, XI, XIV and XVI. The new type XIV Victrola is proving to be a popular seller, but we are not getting enough machines to meet the demands of the trade. The feeling in the trade about the State is much improved and dealers bought exceptionally well this fall. The outlook is certainly bright for a big business next year."

Harry R. Fitzpatrick, traveling representative of the Victor Talking Machine Co. in Wisconsin, northern Illinois and northern Michigan, is covering the trade in western Wisconsin at this writing. Mr. Fitzpatrick is finding himself handicapped by the shortage in Victor goods.

John McCormack, the popular Irish tenor, is scheduled to appear at the Pabst Theater on December 10, and Victor dealers have been swamped with orders for the McCormack records. The new McCormack record, "It's a Long, Long Way to Tipperary," has been proving especially popular.

Operating Large Victor Department.

The Hoeffler Piano Manufacturing Co., 306 West Water street, operating an especially large Victor department under the management of J. H. Becker, Jr., seems to have been one of the few Milwaukee houses which was fortunate enough to lay in a large stock of machines earlier in the season.

"The holiday business is even better than we had anticipated," said Mr. Becker, "but we are supplied with a fine stock of machines. We even stored a large number of the various styles, in order that we might be in readiness for the holiday rush. There is a brisk demand for styles IX and XI. The record business is also exceptionally good. We have nearly 100 Victrolas on our floor and in our demonstrating booths. Our new mailing envelopes, suggesting Victor records for Christmas, together with the colored Christmas list, which I prepared, are bringing excellent results. I believe that this sort of advertising is always satisfactory."

"Ragtime Rastus," a new dancing doll in the Hoeffler window, is attracting considerable atten-

MIGHTY SCARCE, BUT VICTRO In mahogany and a

Stocks of Victrolas XVI at present in the hands of distributors are extremely low and a very acute shortage in this type is expected for the next sixty days. You will find it to your interest to consult us *now* regarding your holiday requirements.

Don't Delay. The Shortage Is Real, Not Imaginary.

PHONE, 7531 MADISON SQUARE

BENJ. SWITKY, NEW YORK
Victor Specialist

tion. The mechanical toy fits any talking machine and dances automatically when the machine plays.

The wife of J. H. Becker, manager of the Hoeffler Victor department, is recovering from her five months' illness.

Now in New and Larger Quarters.

The Roethe-Buelow Co., an enterprising talking machine house located on the Milwaukee south side, formerly at 395 Grove street, has opened in new and larger quarters at 396 Eleventh avenue. The company has been meeting with a steady increase of business and the larger quarters became necessary. The Roethe-Buelow establishment has been termed "the south side's handsomest talking machine store." The company handles the Columbia line and has been meeting with a fine business of late.

The Gensch-Smith Co., 730 Grand avenue, handling the Victor line, is now nicely settled in its additional quarters, which it recently secured, adjoining its store. The company's business during the month of November showed a decided increase over the corresponding month a year ago.

Milwaukee talking machine houses have advertised in the local papers more freely than ever this fall, and it is believed that the big increase in business which has been experienced is one of the direct results. The J. B. Bradford Piano Co., the Edmund Gram Piano House, the Badger Victrola Shop, the George H. Eichholz Co. and Gimbel Bros. and the Boston store, handling the Victor line, A. G. Kunde, carrying the Columbia goods, and the Edison Shop and the Flanner-Hafsoos Music House, selling the Edison line, have been carrying on an especially aggressive newspaper campaign with the best of results.

Paul A. Seeger, manager of the Victor department at the Edmund Gram Piano House, is finding that his total business this season is showing a decided increase over the same period a year ago. The demand for the high priced Victrolas has been especially strong at the Gram house.

The Roethe-Buelow Co., 396 Eleventh avenue, made a sale of considerable interest recently, when it disposed of one of the \$500 Columbia machines

to Fred Oesterreich, a well-known manufacturer on the Milwaukee south side.

A. G. Kunde, 516 Grand avenue, Columbia jobber and dealer, has been receiving many inquiries from teachers and schools all over the State of late regarding the Columbia line, as a result of the successful demonstration of the Columbia machines before the annual convention of the Wisconsin State Teachers' Association, held in Milwaukee last month. General business at the Kunde store has been exceptionally good since the concern opened in its handsome new quarters.

The Edison people are also having their troubles regarding a shortage in some lines of machines, according to William A. Schmidt, manager of the

Phonograph Co., of Milwaukee, jobber in this territory for the Edison goods. The scarcity in the Edison field seems to be especially noticeable in the various oak styles of disc machines. Mr. Schmidt says that dealers in this territory have been buying much more freely than had been anticipated. The disc line has been placed with several reputable Wisconsin houses of late. Business at the Edison Shop, the leading downtown retail Edison store in Milwaukee, is very good at the present time.

Miss Henrietta Kane, formerly with the Koerner Bros. Piano Co., of Milwaukee, has joined the sales force at the Edison Shop, where she is meeting with much success.

HOW THE DEALER IS HELPED.

The Co-operation of the Victor Co. in Helping the Dealer Again Illustrated in Some Remarkable Advertisements in the New York Papers—Names of All the Dealers Given.

The Victor Talking Machine Co., on December 4 and 5, used a full-page advertisement in the local newspapers which marked an era in newspaper advertising in the talking-machine industry. This advertisement appeared in every New York evening newspaper on the 4th of the month, and was repeated in every local morning paper the day after. The size of the advertisement and its simultaneous appearance in all the local papers was sufficient in itself to attract the attention of the public, aside from the forceful copy used and the decidedly unique character of the text.

This full page was headed "Victor Supremacy," and the heading was followed by two short and pithy paragraphs calling attention to the fact that the world's greatest artists make records for the Victor Co., and emphasizing that the scope of the Victrola is unlimited. To support this text, a border was used portraying twenty-eight of the world-famous artists who record for the Victor library. This border was completed by an unusually sharp and clear cut of a Victrola XVI, with the internationally popular Victor trade-mark.

The unique and remarkable phase of this advertisement, however, consisted of the listing of all the Victor dealers in New York and vicinity, this list being the first one of its kind ever published. The publication of these names represented more than a mere list of representatives of the Victor Talking Machine Co., as it served to permanently impress the reader with the prestige of the Victor products and the remarkable popularity that they have achieved in the past few years. The sales value of the page is unquestioned, and the Victor Co. has been in receipt of congratulations from its dealers throughout the country, who regard the advertisement as a publicity and sales masterpiece.

The numerical strength of Victor representation in local territory may be gathered from the fact that 241 names were listed in the advertisement. Exactly 100 Victor dealers are located in the Borough of Manhattan, fourteen in the Bronx, and seventy-five in Brooklyn. The remainder of the list included Victor dealers in Staten Island, Queens, Westchester County, Newark, Jersey City and Hoboken, N. J.

The dealer who understands the power of advertising will not be a price cutter. He will be a conservationist, not a pirate. He will push his business on service lines. Service brings him the good will and fixed habits of satisfied customers.

**-WE HAVE THEM
LAS XVI
few assorted finishes**

Fellow-Distributors will be accommodated with moderate quantities of Victrolas XVI on an exchange basis.

We foresaw the present shortage and are prepared to take care of dealers and distributors.

PHONE, 7531 MADISON SQUARE

**BENJ. SWITKY, NEW YORK
Victor Specialist**



For quality, variety, interest and activity the Columbia Record List for January is a symphony!



(Write for "Music Money," a book "full of meat" for those dealers interested in quick and frequent turnover of capital.)

Columbia Graphophone Company
Woolworth Building, New York

OPENS HANDSOME DISPLAY ROOMS.

New Victor Rooms of Chas. E. Roat Music Co. Most Attractive — Flashlight of Photographer Brings Fire Department and Some Unexpected Publicity in Its Wake.

When the Charles E. Roat Music Co., of Battle Creek, Mich., completed its beautiful Victor display rooms it was so well pleased that it decided to let the trade see, through The Talking Machine World, what it had accomplished. Whereupon two members of the sales force, accompanied by E. T. Merchant, local commercial photographer, withdrew on an evening to the scene and proceeded to take

the economy of space, a worthless basement being transformed into a valuable sales department. The rooms are so arranged that a customer may be shown all models of machines at one time and from one position without being inconvenienced or annoyed by outside influences. Rustic decorations and portraits of various artists form a decorative scheme pleasing to the eye, while a semi-indirect lighting system gives the rooms a soft, mellow glow in perfect harmony with the rest of the setting.

SING A SONG OF BUSINESS.

Suppose we hadn't ever heard about this blooming war; suppose the cables had been cut that run from shore to shore; suppose that England, Germany and Russia and Japan and France had cut the cables off before the war began; suppose we never heard a word of shot and shell and flame—we guess the great United States would go on just the same.

We're big enough and strong enough and have enough of crops, says the American Lumberman. We need

the stuff the farmers raise; the farmers need the shops. If Europe wants to scrap around and spend its cash in hand; if Europe wants to make itself look like cut over land, then we should worry quite a lot about the fighting game—we guess the great United States can go on just the same.

So let's forget about the war, the battles and the bombs, and keep on doing business here until the tempest calms. Instead of shipping stuff to France, to Germany or Rome, we'll make the stuff our people need and sell it here at home.

MAKE ALLEGANY COUNTY MUSICAL.

Twenty-five Victrolas in the Schools of That County Serve to Cultivate the Musical Tastes of That Section of Maryland.

While there have always been many lovers of music in Allegany County, this county as a whole has been far in the rear of other sections of the East in music. Great strides have, however, been made in this direction since the invention and marketing of the different talking machines on which music—vocal and instrumental, by the greater and lesser artists of the day—has been reproduced. This is especially true since the Victrola has become so popular in this vicinity, and musical events which formerly were unable to muster an audience of any size are now crowded long before starting time.

And now comes the introduction of the Victrola—especially constructed for the purpose—into the graded public schools of the country. Twenty-five of these Victrolas have been placed in as many public schools of Allegany County, and under the splendid work of Miss C. B. Morse, supervisor of music for the county, backed and aided by the work of County School Superintendent John E. Edwards, and the principals and teachers of the graded schools, the musical education of the children of the county will be started in the public schools, and they will have a chance to hear the best music of the old and latter-day masters sung and played by artists of world renown and given to them under the direction of one ably fitted to instruct in music.

The twenty-five Victrolas have been placed in the schools by the Morrison Music Co. and will be paid for by the several schools without taking a cent from the public school fund for the purpose. It is understood that the money to pay for the machines and the necessary records will be raised by other easy means, and some of the Victrolas have already been paid for. This move by Miss Morse is bound to become a popular one with the pupils, and will undoubtedly make them lovers of the best in music in the years to come.—Cumberland (Md.) Daily News.



Handsome Victrola Room of Chas. E. Roat Music Co., Battle Creek, Mich.

the above flashlight photograph. After taking the picture they were congratulating themselves on their success when—crash! a breaking of glass called them to the next room, where a fireman came wriggling through the transom window. Upon the main floor the situation proved still more humorous when it was learned that a passer-by, seeing the smoke from the flashlight, had turned in an alarm calling out four fire companies. The total damage was less than \$1.

The company's new display rooms, one of which is shown in the photo, are an excellent example of



Owing to the war, shipments of Lexton Needles from Europe, now on the way, have been delayed. Pending orders will be filled in regular order.

DO YOU WISH TO PLAY EDISON DISCS?

Price \$2.00

(Sample to Dealers \$1.00)

LEXTON SPECIALTY CO., 216 West 99th St., N. Y.

YOUR CHANCE IS HERE

to make the Holiday Season of 1914 the High-Water Mark in Your Business History.

You must have a large stock of patience, willingness, machines and records, and, in addition, a value-proven and profit-proven line of Cabinets.

The Sale of a Small Machine will not be "Small" if there goes with it a



CABINET No. 19 AND VICTROLA IX

SALTER

FELT-LINED CABINET

(MADE TO MATCH ALL MAKES OF MACHINES)

Old customers as well as new make excellent Christmas prospects.

Every machine owner whose name is in your files needs and will welcome this suggestion for record storage.

REMEMBER—With the piles of records off the table and chairs your record sales will be bigger.



STYLE 120 "OVERFLOW" CABINET.

**SALTER CABINETS—
STANDARD IN
THE INDUSTRY**

SALTER MFG. CO.

Send for Catalog

337-39 Oakley Blvd. CHICAGO



With the "one complete line" and Columbia exclusive rights, you can tune the talking machine business in your district to any keynote you like the sound of.



(Write for "Music Money," a book "full of meat" for those dealers interested in quick and frequent turnover of capital.)

Columbia Graphophone Company
Woolworth Building, New York

THE TALKING MACHINE TRADE A BRIGHT SPOT

In the Music Trade Field of Kansas City—Present Conditions and General Prospects Most Satisfying and a Large Holiday Trade in Talking Machines Expected—Jenkins Publicity Attracts Thanks to Col. Hunter—Blackman Heads Phonograph Co.—The News.

(Special to The Talking Machine World.)

KANSAS CITY, Mo., December 8.—The talking-machine business in Kansas City has been the only bright spot in music business in Kansas city this fall. As one man expressed it: "The talking machine has been an oasis in the desert of bad business." Now that the Christmas rush is well under way most of the dealers are doing considerable advertising in the newspapers as well as other mediums of advertising. It is the consensus of opinion among the trade that regardless of how trade in general music lines will be during the holidays, the business in talking machines will be above normal.

Harry Wunderlich, manager of the F. G. Smith Piano Co., says that he is very much gratified with the amount of business done this fall as well as for the prospects for the winter. Mr. Wunderlich recently returned from New York, where he spent several days. In speaking of business conditions there, compared to Kansas City, Mr. Wunderlich intimated that he believed them to be better here than there.

An Excellent Record of Sales.

There is hardly a piano dealer in Kansas City but says that the talking machine sales during the past three months have far outstripped the piano sales. This demand has not been for cheap machines, as might be supposed, but for the higher-priced machines. A. A. Trostler, of Schmelzer Arms Co., who has charge of the wholesale lines for the Victrola in this territory, says that it has been difficult to keep up with the demand for high-priced Victrolas, and the prospects are that the holidays will find the supply a trifle short.

Opens Special Holiday Quarters.

The Hall Music Co., E. S. Hall, manager, the only exclusive Victrola dealer in Kansas City, and

which has developed a nice line of customers in its seven years, has opened holiday quarters near Ninth, on Walnut streets, in the Scarritt building. This is a busy location, where thousands pass daily; there is a large display window, and the entrance is through a special door adjoining the ornate entrance to the building; there is another entrance from the lobby of the building. The company has built up its trade largely through personal relations, the use of circulars, etc.

Elmer A. McMurtry, manager of the Columbia Graphophone Co., reports high price machines in good demand, and a fine Christmas trade under way. He also is in the situation of having more calls for records than can conveniently be handled, the demand being general.

Joseph A. Mullen, manager of the talking-machine department of the Carl Hoffman Music Co., spent Thursday, December 2, in a state of ecstasy, which was not due solely to the fact that November business had exceeded the trade of November, 1913, by forty per cent. There was another very good reason for his rejoicing, namely, the receipt, after a long wait, of a supply of records of "It's a Long, Long Way to Tipperary." There has been a great demand for the record. Mr. Mullen reports that the \$100 machines have been the best sellers this season.

Clyde C. Thomas, manager of the Field-Lippman piano store in Kansas City, reports his Victrola sales to be a redeeming feature of the fall and winter trade, and the prospects for late winter and spring are certainly fine, he adds.

M. M. Blackman, formerly in charge of the retail record department of the Lyon & Healy Music Co. at Chicago, has succeeded W. P. Hope as manager of the Phonograph Co. of Kansas City. The business of this distributing office has grown

markedly; and indications being such that two salesmen have been added to the retail force, George Maxey and H. I. Hancock. Mr. Blackman is confident that the present favorable business conditions will hold out all winter.

Bird A. Ward, formerly with the Texas-Oklahoma Phonograph Co., is now traveling for the Phonograph Co. of Kansas City, and is sending in most gratifying returns from his territory.

Some Clever Christmas Advertising.

You have to hand it to Col. W. C. Hunter, advertising manager for J. W. Jenkins' Sons Music Co.—whenever there is a chance, his department seizes upon it, and lets no phase of the opportunity slip away. The talking machine department of the establishment was certainly a good bet this holiday season, and while other departments have been given very careful and extensive attention in the advertising displays, a special stunt was pulled off with reference to Victrolas that is causing a lot of conversation. Just when the seasonal campaign began, several corner storerooms at prominent transfer point suddenly blossomed out with the Jenkins advertising of Victrolas, the windows being chock full of displays of instruments and pictorial advertising. At first glance it seemed to the passers-by that Jenkins' had opened many branch houses—one couldn't see within whether there was a store or not. But investigation by those who got to the sidewalk disclosed the fact that the rooms had merely been rented for the holiday presentation of the Victrolas. Such prominent locations as Fifteenth street and Troost avenue and Thirty-first and Holmes streets were chosen.

There is usually a small crowd around the big plate-glass window of the Phonograph Co. of Kansas City, the Edison distributing place, where the bronze frame containing a plush cushion, on which an Edison reproducing needle rests, is displayed. A large reading glass in position above the needle magnifies the diamond point several times, and the passers-by stop to examine it closely, being impressed with the "point" made.

CHRISTMAS BOXES FOR RECORDS.

In accordance with its custom of former years, the New York Talking Machine Co., 81 Chambers street, New York, Victor distributor, has ready for its trade handsome Christmas boxes for Victor records, which it will furnish its dealers at cost. These boxes, which are made in two sizes for the 10 and 12-inch Victor records, are decorated appropriately for the Christmas season and contain an expensive and beautifully embossed Christmas card, which tends to enhance the gift.

NEW ATTACHMENT ANNOUNCED.

A new attachment permitting of the playing of Pathé disc records on the Edison diamond disc machine was announced last week by the F. C. Kent Co., Newark, N. J., which is working to capacity to turn out a sufficient quantity to handle the orders it has already received. This attachment has been perfected after extensive experimentation and is furnished complete with a sapphire.

"Standard" Record Cleaner

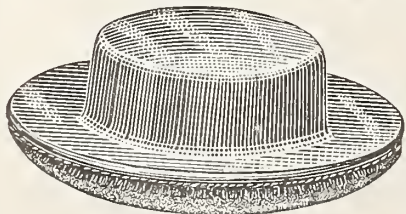

Price, 50 Cents, List
Patented June 2, 1914.

Send 10 cents in stamps for a sample cleaner. Write on your business letter head only. Place regular orders through your jobber.

STANDARD GRAMAPHONE APPLIANCE CO.

173 LAFAYETTE STREET

NEW YORK

We also manufacture the Simplex Record Cleaner, Price 15 cents, list.

ARTISTIC AND ATTRACTIVE

Grips the record surface and clings as if on rails.

Extended brush area cleans record with one sweeping circuit.

THE NEW GENERAL MANAGER OF THE COLUMBIA CO.

A Man of Rare Executive Ability, a Calm, Clear, Logical Thinker Who Quickly Grasps the Kernel of an Intricate Proposition—Some of His Important Appointments.

John A. B. Cromelin, whose appointment as general manager of the Columbia Graphophone Co. was announced in last month's World, has been appointed to this important position with all the fulness of authority and freedom of operation which have always been vested in the general managership.

Few men in any business have had as broad a business training as General Manager Cromelin. In many positions of responsibility, in many lands, he has filled those positions capably and with uniform business-building success.

Mr. Cromelin entered the Columbia service at the bottom of the ladder, eighteen years ago,

turns out and for the type of men who are the brains back of the product.

When you meet Mr. Cromelin you are first of all impressed with his pleasing personality, and further with the fact that he is a calm, clear, logical thinker—an analytical thinker—quick to grasp the kernel of an intricate proposition and quick to realize its possibilities in a broad way. Two principles which he has consistently followed and which have played a prominent part in his successful European administration are interesting to note, as they serve as a prophetic sidelight on his probable operations here. One is that in choosing business associates the rule should be "90 per cent. Selec-



John A. B. Cromelin Snapped by the World Photographer at His Desk.

served as private secretary to the president, and later as assistant executive officer in the factory at Bridgeport. Thirteen years ago he was transferred to Europe where he was employed in Paris and Berlin. He was St. Petersburg manager, and for the last four years European general manager, with headquarters in London.

It is in this last-named position that Mr. Cromelin's rare executive ability, backed by soundness of thinking and policy planning, has found such profitable expression. He took the European helm after the panic of 1907, when business in Europe was being operated at a loss, developed it, and in a short time put it on a profitable and sound business basis. His problems were not alone sales getting, but manufacturing; and the London factory to-day stands as a model of factory efficiency, both on account of the high quality of product it

tion—10 per cent. Supervision." The other, "The dealer, first and foremost."

Since his promotion to the general managership, Mr. Cromelin has made the following appointments: Edward N. Burns, vice-president and manager of the Columbia export department, has been placed in charge of the foreign record department.

H. A. Yerkes, wholesale manager, is now district manager of New England, also including in his territory, Washington, D. C.; Atlanta and Birmingham.

R. F. Bolton, manager of local wholesale store, has been appointed district manager of New York territory, including Buffalo and Rochester.

Seth H. Nichols, manager of the Pittsburgh wholesale headquarters, is now district manager of that territory, with the additions of Cincinnati, Cleveland and Toledo.

honor upon Thomas A. Edison, the inventor. The bill carries an appropriation of \$5,000 for use in preparing the medal, which would be selected by a committee consisting of the President, the Vice-President and the Speaker of the House.

TRADE OUTLOOK IN NORTHWEST.

New England Furniture Co. Increases Its Line of Talking Machines—New Edison Branches—Great Increase in Victor Business—Attractive Columbia Window.

(Special to The Talking Machine World.)

MINNEAPOLIS and ST. PAUL, MINN., December 10.—H. G. Derrick, manager of the Victor department of the New England Furniture Co., recently added the Edison disc and the Columbia Grafonolas, and is showing the three lines in adjoining compartments.

"It's the only way to run an independent talking machine store in my opinion," explained Mr. Derrick, to The World correspondent. "When a buyer's fancy or judgment has been caught by a certain kind of machine, it is much easier to sell him that particular kind than to convince him that he ought to buy something else. Our sales have been largely increased by the addition of the two new lines, and that without diminishing but rather stimulating the sales of the first line."

Three new Edison branches have been opened in the Twin Cities since the November issue of The World went out, namely, by Foster & Waldo, and the New England Furniture Co., Minneapolis, and the Golden Rule department store, St. Paul. The deals were made by Laurence H. Lucker, of the Minnesota Phonograph Co. The Edison discs, he reports, are growing rapidly in popular favor, largely through the two new elegant stores in St. Paul and Minneapolis, which command attention by the beauty of their design and arrangement.

W. J. Dyer & Co., general jobbers for the Victor Co. in the Northwest, report a great increase in business. "Our sales of late have averaged \$3,500 daily," said Mr. Dyer, "and we easily could increase that 25 per cent. if we could get the goods. We know that the Victor Co. is bending every effort to supply the demand, and we probably are as well supplied as any other house, but naturally we must feel some regret when compelled to decline some good business. We are making many sales of high-class machines for Christmas gifts, and have set aside a large room for machines to be delivered Christmas morning. The demand for this class of musical instruments shows no sign whatever of abatement, but rather there is a constant growth."

Manager C. P. Herman, of the Columbia store in St. Paul is working out an attractive window display for the holidays. The scheme will be in white with frosty wintry effects, but poinsettias and holly too will be used liberally to add color to the setting. A full line of the Columbia machines will be shown, from the smallest to the largest.

Miss Ellis, late of the Biltmore, New York, is showing all the modern dances in the new Edison shop on Nicollet avenue, Minneapolis.

AN INVENTION THAT INTERESTS.

(Special to The Talking Machine World.)

BOSTON, MASS., December 10.—An invention that is taking by storm owners of talking machines is the dancing Rastus, which was first introduced by the Columbia Graphophone Co., though it was not long before most all of the talking machine houses had the contrivance. It is a clever arrangement—a nimble doll-like figure, with loose legs and arms, dances untiringly on a board over the machine while the instrument plays a lively dance. It is really a most clever invention, and it is being eagerly sought at all the stores now.

WINNING SUCCESS ON COAST.

Frank M. Steers, president Sonora Phonograph Co., Phelan building, San Francisco, Cal., was in town last week consulting with Geo. E. Brightson, president of the Sonora Phonograph Corporation, 57 Reade street, New York. Mr. Steers reports that since the establishment of the new company with its warerooms, business is being booked all the time and the future looks bright not only in San Francisco, but all along the Coast.

"The entire Pacific Coast is wonderful talking machine territory," added Mr. Steers, "and I might say that the people of this area have a sufficient income to represent an excellent volume of business."

WANTS MEDAL FOR THOS. A. EDISON.

Representative Robert H. Gittins, of New York, recently introduced a bill in the House in which he proposes that Congress shall confer a medal of

"MAGNET" DECALCOMANIE NAMEPLATES



From the
DORAN CO.
45 MICHIGAN AVE.
DETROIT

**FOR TALKING MACHINE
CABINETS ETC.**

EASILY AND PERMANENTLY APPLIED.
BE THE FIRST DEALER IN YOUR CITY
TO USE THIS POPULAR METHOD OF AD-
VERTISING.

500 MINIMUM QUANTITY MANUFACTURED.
SEND FOR SAMPLES AND PRICES.



FROM
THE PHONOGRAPH CO.
1240 HURON ROAD (Facing Third Floor)
PHONES - PROSPECT 2-10 - CENT 1406
CLEVELAND

SOLE BY
HURTEAU WILLIAMS & CO. LTD.
MONTREAL - OTTAWA

SOLE BY
Kunkel Piano Co.
BALTIMORE

SOLE BY
WALTER D. MOSES & CO.
Oldest Music House in Va. and D.C.
103 E. BROAD STREET
RICHMOND, VA.

SOLE BY
GEO. A. SMITH & CO. INC.
74 CORTLANDT ST., NEW YORK

SOLE BY
J. E. STRATFORD
AUGUSTA, GA.

THE TRADE IN NEW YORK CITY AND VICINITY

The local talking machine industry the past month has stood out conspicuously as one of the very few industries which maintained sales totals that compared favorably with the figures of last year. As a matter of fact the local business in talking machine circles during November exceeded all expectations, in that the majority of dealers reported a substantial gain over last November's business, and hardly a member of the trade reported a falling off in machine or record sales as compared with November, 1913. This prosperity is remarkable in view of the unsettled conditions which exist in practically every other retail mercantile field in New York at the present time. The stability and strength of the talking machine industry has long been acknowledged in financial and commercial circles, but the wonderful sales records which have been established this year in the face of unparalleled conditions place this industry far in

advance of many industries established years before for the talking machine was placed on the market.

The prosperity which is now prevailing in the talking machine industry may be attributed in a considerable measure to the valuable co-operation which the manufacturers have extended their distributors and dealers by stimulating the demand for machines and records in every conceivable way. When it is considered that the money market has been unsettled since the first of the year, and financial circles throughout the country have been generally disturbed, the fact that all the manufacturers are closing the best year in their history would give a fair idea of the machine and record demand which they have developed.

The most important feature of local trade the past month has been the volume and character of the newspaper publicity used by the industry as a whole. The leading manufacturers have been using

printers' ink to a greater extent than during any previous holiday season, and this advertising has been well calculated to enhance the musical prestige and sales possibilities of both machines and records. In addition to this general publicity individual dealer advertisements have been published daily, and there has been hardly a local newspaper which has not carried large announcements of talking machine dealers and manufacturers.

Shortage in Some Types of Machines.

As predicted in these columns the past two months, there now exists a marked shortage in machines of certain types and many classes of records. The demand for machines this fall has inclined perceptibly to the models retailing at \$75 upwards, and it is in the \$75 and \$100 types that the most serious shortage exists. Those dealers who decided to order machines and records as they were needed in preference to placing their customary advance orders for the holiday season have been seriously handicapped by their lack of confidence in the business outlook, and have doubtless lost a number of sales through their inability to supply both machines and records when they were actually required.

Activity in Upper New York.

In that thriving and popular section of upper New York, 125th street, which is quite a talking machine center, the various stores have arranged some very attractive windows for the holiday season. Worthy of special mention is I. Davega, Jr., who devotes a window to a "Tipperary" display, soldiers moving out of the sound chamber of a \$25 Victrola over a bridge into the sound chamber of a similar machine on the other side. The movements of the troops are most picturesque, and the attention the display attracts emphasizes the interest in the famous marching song of the Allies. Another attractive window preceding the foregoing was devoted to the making of the Victor records. An artistic window is that of the Columbia Graphophone Co., which is admirably arranged with a true Christmas atmosphere, the various styles being on exhibition. Kranich & Bach have a very attractive window in which the Victor and Columbia machines are displayed—in fact, the talking machine stores throughout the district are all up-to-date and evidently doing a good business.

Good News from New York Talking Machine Co.

"November business was simply wonderful," said V. W. Moody, sales manager of the New York Talking Machine Co., 81 Chambers street, Victor distributor. "December of last year was of course the best month of that year, and in fact the best month in the history of our company, and as our figures for this November just about equal our totals of last December, the magnitude of our current business may be realized. The improved Victrola XIV and the XVI, with electric motor, are proving very popular with the trade, and because of the Victor Co.'s inability to make large shipments of these new types, the more thoughtful dealers are literally screwing their machines to the floor, and hanging on to them like grim death. The percentage of increased record business as compared with 1913, is running slightly ahead of the gains in machine trade, not because the machine business has fallen off, but owing to the tremendous growth of the record business."

Closed Great November Trade.

Anent Columbia prosperity, R. F. Bolton, district manager of local wholesale territory, with headquarters at the branch at 89 Chambers street, said: "We have just closed the best November in the history of our company. As a rule, our November trade falls somewhat below October business, but this year it has been different, and last month was 20 per cent. better than October. There has been an enormous demand for the Leader and Mignonette machines with both the record racks and the new record ejector, and we have been taxed to the utmost to secure a sufficient stock of these

(Continued on page 24.)

The Spirit of Christmas Is Here With Us Now Business Is Good

The Victor Talking Machine Company's vast publicity and attractive literature have stimulated an interest and it is for you to reap the harvest.

Are you prepared?
See to it to-day.
We can supply your needs.

C. Bruno & Son, Inc.

ESTABLISHED 1834

Victor Talking Machines Musical Instruments

351-353 Fourth Ave. New York

"Little Things That Count"

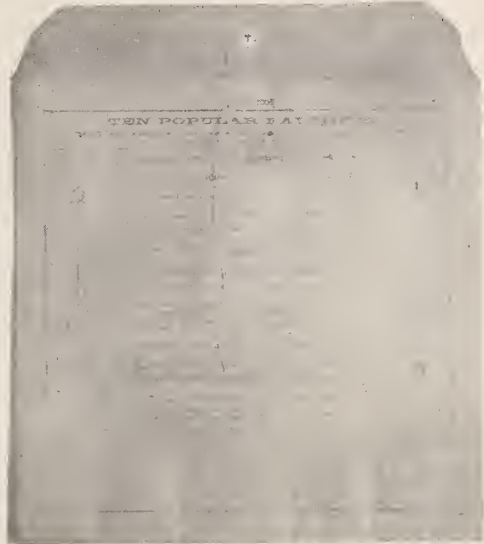

DELIVERY BAGS

With Dealer's Imprint \$11.00 per 1,000
Additional Discount on Quantity Orders.



SPECIAL CHRISTMAS LISTS

"Christmas Records" Lists . . . at 35c. per 100
"\$25.00 Gift Lists" at 25c. per 100
"\$10.00 Gift Lists" at 20c. per 100



CHRISTMAS BOXES
(With Card)

10 inch 10c. each
12 inch 12c. each

Five Good Reasons

Why You Should Identify
Yourself With

Our Service



STOCK ENVELOPES

10 inch \$12.00 per 1,000
12 inch \$15.00 per 1,000
Prices Subject to Discount

DEALERS' RECORD RACKS
\$27.50 net per section

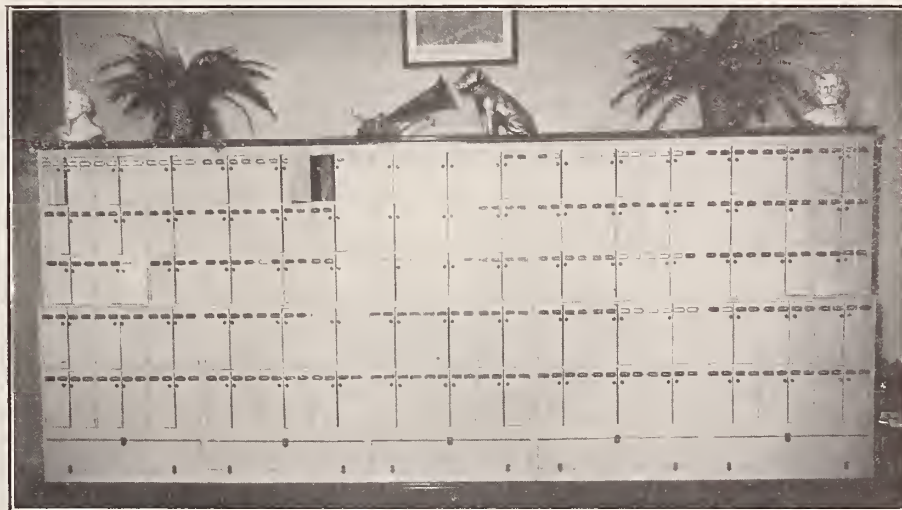

Above Illustration Shows 5 Sections, Accommodating 5,000 Records

Write for Pamphlet "Complete Stock System for Dealers"

New York Talking Machine Co.

81 Chambers Street

New York



A line of foreign records, representative of every country in Europe, is to-day strengthening every Columbia dealer in handling the present phenomenal demand for European national music.



(Write for "Music Money," a book "full of meat" for those dealers interested in quick and frequent turnover of capital.)

Columbia Graphophone Company
Woolworth Building, New York

THE TRADE IN NEW YORK CITY.

(Continued from page 22.)

models. Foreign record trade is increasing steadily, and the war abroad has created a surprisingly large demand for records of a patriotic strain. Collections are generally good, and the outlook as a whole is very promising."

Edison Diamond Disc Popular.

"The prestige of the new Edison diamond disc product is becoming more firmly established week after week," said A. W. Toennies, of the Eclipse Phonograph Co., 203 Washington street, Hoboken, N. J., exclusive Edison jobbers. "The wonderful musical effects which may be obtained from the combined use of the Edison disc phonograph and the Edison disc records have made these products popular among musicians who formerly ridiculed the musical standing of the phonograph or talking-machine. Last month was one of the best in our history, and the quality of the Edison disc product and the up-to-dateness of their new records have enabled our dealers to consummate an excellent holiday business, which was better than they had ever hoped for."

Pathé Frères Phonograph Co. Progress.

The Pathé Frères Phonograph Co. has been making steady progress in introducing its products to the local trade, and during the past fortnight has signed a large number of dealers' contracts in this territory. The unlimited Pathé record repertoire and the many distinctive qualities of the Pathephone have won the favorable attention of dealers throughout the country. Among the most recent new accounts are Ludwig Baumann & Co., 125th street, the prominent furniture house; the Harlem Sewing Machine and Talking Machine Co., 1529 Madison avenue; B. G. Warner, Brooklyn, N. Y., and Hardman, Peck & Co., 433 Fifth avenue, one of the best-known high-grade piano houses in the country.

J. N. Blackman Is Optimistic.

"The demand for machines is greatest in the models retailing at \$50 and upwards," remarked J. Newcomb Blackman, president of the Blackman Talking Machine Co., 97 Chambers street, Victor and Edison cylinder distributor. "Our machine trade has been excellent, and our sales totals for November showed a substantial gain over last November. This industry is a conspicuous exception to general business affairs, in that it has been steady and prosperous in the face of unexpected commercial disturbances. The only thing that we must watch carefully is collections, and the dealer should try to merchandise his product at fair and equitable terms which will net him a profit without any fear as to the responsibility of his customers. He should not sell goods on terms which might embarrass him later on."

Aeolian Co.'s Active Campaign.

The Aeolian Co. has been conducting an extensive campaign on behalf of the products of the Columbia Graphophone Co., which has been producing splendid results. Cowperthwait & Co. has also used considerable newspaper space to advertise its Columbia department, and Manager Woolley states that the response to this publicity has been most gratifying. Other new Columbia agencies

have realized the advantages of acquainting their trade with the merits of Columbia goods, and as a result, Columbia local trade has exceeded by far last year's sales totals.

Landay Bros. Increasing Wholesale Trade.

Landay Bros. Victor distributors are doing a very satisfactory business, as summed up by Max Landay, president of the company, who says: "Up to the first of December our general trade was very good indeed. The reports of the dealers whom we are serving would indicate that their individual stores were prosperous and busy, in spite of the conditions brought about by the war abroad. Our advertising in The Talking Machine World has brought us a large number of inquiries from dealers, the majority of which we have been obliged to refuse, because we are serving a limited number of dealers only, but after the first of the year we expect to increase our facilities for handling wholesale trade considerably. We believe in concentrating our efforts rather than scattering them, and it has been this policy which has built up our retail trade. This same system of concentrating on a comparatively few dealers and serving them well has been a prime factor in the growth of the wholesale trade."

HELPS TO INCREASE ORDERS.

How E. G. Evans Uses His Automobile to Get Victor Orders for C. Bruno & Son, Inc.

In this age of efficiency it is interesting to note the method adopted by E. G. Evans, special Victor representative of C. Bruno & Son, Inc., 353 Fourth avenue, New York, who recently purchased an American underslung automobile, primarily for use in calling upon the trade. Mr. Evans makes this significant statement, that with a car he is enabled to make 50 per cent. more calls daily, with a corresponding increase in the amount of Victor sales, there being in this particular remark a big hint for many talking machine men as to how to increase business.

Inasmuch as the foregoing move was at his own volition, Mr. Evans is to be congratulated upon his endeavor to get the greatest amount of business from his daily time.

VISITING THE UNITED STATES.

Louis Sterling, who was recently appointed general European manager of the Columbia Graphophone Co., arrived in New York late last month on the steamer "Franconia." Mr. Sterling, whose headquarters are in London, England, is visiting this country to confer with the executives of the Columbia Co. regarding future policies and important matters relative to his new post. He was accompanied by Mrs. John A. B. Cromelin, wife of the recently appointed general manager of the Columbia Co., and their family.

The Audubon Grafonola Co., a newly organized retail concern at 3750 Broadway, New York, has arranged to handle the Columbia Co.'s complete line exclusively in its establishment, and has placed a substantial order for stock for the holiday trade.

VOCA PHONE LATEST WRINKLE.

New Device Turns Whispers Into Loud Talk at Long Range—Must Watch Your Speech.

You might as well be warned at once that anything you say will be used against you. And you don't have to say it loudly. You can whisper it and not escape. For now comes the voca phone, "the box that hears and talks." Gaillard Smith, president of the Detecta Phone Co. of America, and responsible for the instrument beloved of detectives and fiction writers, from which the company takes its name, fathers this new instrument.

It is the natural offspring of the telephone and resembles its parent. But when you swing over the arm carrying the receiver you hook up a mechanism that magnifies sound many times, so that instead of whispering privately into the ear of the person at the other end of the line, the voca phone talks to him distinctly, even though he be many feet away from the instrument. And he can talk back without bothering to get out of his chair.

Mr. Smith's voca phone isn't ready for the market yet, but it is already in the drama, for last week he invited his friends to witness a private view of "The Riddle of the Green Umbrella," in which Alice Joyce as a girl detective startles the villain quite out of his villainous self-control by dropping a voca phone down the chimney and announcing through it that the spirit of the villain's victim "will be revenged."

It is not, however, as an instrument for making folks uneasy that Mr. Smith presents the voca phone. It is intended primarily as an ideal means of intercommunication between rooms, offices, factories or the various widely separated units of any industry. It is meant for short distance work, but Mr. Smith said that it had worked satisfactorily at twenty miles.

"As an illustration," said Mr. Smith, "suppose a lawyer sitting in his office wishes to consult a book in his library. His voca phone is switched on and he does not move from his desk. 'Look up volume so and so, page 241, and read me the second paragraph,' he says. And the clerk, climbing a ladder and finding the volume on the top shelf, can stand there and read the desired reference, his words being transmitted as clearly as though he stood at the lawyer's elbow."

RECIPE FOR GOOD HUMOR.

Take twenty-four hours; mix thoroughly with the milk of human kindness, and spice of life to suit the taste; a little discretion, some common sense; knead with the hand of friendship and bake in the open hearth of love; do not allow it to cool too quickly by trouble, or become sour by affliction; serve with generous sauce and a bright smile.—Washington Star.

F. W. Swan, who for forty-four years has conducted a jewelry store at Muscatine, Ia., has become an Edison disc dealer and has recently placed a good sized order for Edison instruments.

STEADY RECOVERY OF GENERAL BUSINESS NOW EVIDENT.

National Civic Federation Finds Optimism in Most Quarters—Encouraging Reports from Over Six Hundred Sources—Some Interesting Conditions Revealed by Some of the Letters Received—Railroads Declared to be Pessimistic.

Business improvement, with increase of prosperity for the immediate future and steady betterment thereafter, is the summary of the findings of John Hays Hammond, chairman of the industrial economics department of the National Civic Federation, as the result of a widespread canvass of conditions throughout the country. Mr. Hammond has had reports during October and November from about 600 correspondents, including governors, mayors, officials of national banks, savings banks, railroads, associations of manufacturers, boards of trade, life insurance companies, State federations of labor, trade unions, provident loan societies, State labor bureaus and charity organizations.

Mr. Hammond presented a report on this correspondence to the annual meeting of the National Civic Federation, held at the Hotel Astor recently, when the problem of unemployment and the other financial and industrial questions arising out of the war was considered.

"Business throughout the United States is improving and the conviction that a further advance toward prosperity will be made in the next few months is widespread," says the summary of the report. "Improvement in financial conditions and the resumption of exports have been followed by signs of improvement in many quarters.

Improvement Is Gradual.

"The resumption of normal business activities must be gradual and the unusually large number who are now unemployed will find work slowly. We must expect a great deal of unemployment in the coming winter months. By far the most gloomy view is that taken by nearly all the charity organizations. New York city reports applications for relief 45 per cent. more numerous than a year ago, while in smaller places such organizations find their work increased from 20 per cent. to 100 per cent. over last year.

"But it is highly significant that in the many gloomy letters from charity officials and trade union authorities there is no note of actual despair and no advocacy of untried experiments to relieve poverty.

Railroads Are Pessimistic.

"Next to the charity organizations, railroads are the most pessimistic. Several of the great manufacturing associations insist that an increase in freight rates would do more for the permanent prosperity of the country than even the ending of the foreign war.

"Largely owing to the railroad situation many of the great fundamental industries have been for a long period exceedingly quiet. But reports now come in of new building projects in the Middle West. The concrete trade is picking up and to a slight extent this is true of the electrical trade, although machinery lines still appear very quiet. The president of one of the greater steel companies says that in his opinion the bottom has been reached in the steel trade.

"A markedly large number of letters emphasize the service which the opening of the Federal Reserve Banks is expected to afford. Not only do bankers make this point; manufacturers and merchants are even more impressed with benefits to be expected from these new institutions.

"Numerous letters refer to the lowering of money rates that has taken place in the last month, especially in the Middle West, and the consequently freer movement of trade. Another significant feature is the improvement in the savings bank situation. The great savings institutions of New York city report that business is now altogether normal.

"The last few weeks have brought about a little convalescence even in those industries which seemed wholly crippled. From mayors of cities in North and South Carolina, Alabama and Georgia come more cheerful views of the situation there.

"Many letters tell of purchases of supplies by belligerent nations.

"In the great farming region west of the Mississippi and east of the Rocky Mountains, and to a somewhat less extent in the agricultural sections of more Eastern States and the Pacific Coast, local conditions of prosperity, because of the unusually good crops have prevented any serious effects from the war."

CLOSED MANY IMPORTANT DEALS.

Clifford R. Ely, traveling representative of the Columbia Co.'s wholesale department, returned to New York last week after spending 123 consecutive days in traveling through the South, middle South and Northwest. Mr. Ely reports conditions as being remarkably auspicious for Columbia prosperity, and secured orders from Columbia dealers which far exceeded the orders they placed in November of last year. Mr. Ely states that conditions in the South are, of course, considerably below normal, but notwithstanding these handicaps, Columbia dealers are selling plenty of machines and records, in the majority of instances running ahead of last year's sales totals. Mr. Ely, while on this extensive trip closed a number of important deals for new Columbia agencies, including the Lenhart Piano Co. St. Paul Minn., and others.

PLAYER AND PHONOGRAPH.

Combined in Patent Granted to S. S. Waters and Assigned to the Aeolian Co.

(Special to The Talking Machine World.)

WASHINGTON, D. C., December 9.—The Aeolian Co., New York, are the owners through assignment by Samuel S. Waters, Washington, D. C., of Patent No. 1,119,333 for a Combined Player-Piano and Phonograph, and relates to a combination of musical instruments especially adapted for the

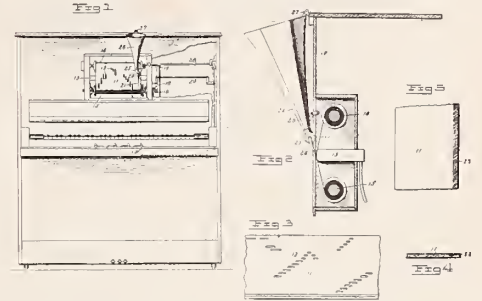

playing of two musical instruments together and in the same musical time, and is particularly adapted for the playing together and in the same musical time two different or dissimilar instruments. In the specific embodiment of this invention a piano and a phonograph reproducer mechanism are combined. While of the particular relation and adaptation stated, however, this invention is capable of use in connection with instruments of other types than those specified.

**A
BLACKMAN
TIP**

**"SATISFACTION AT BLACKMAN'S
COSTS NO MORE
THAN
DISSATISFACTION ELSEWHERE"**

(BLACKMAN)

If you are PARTICULAR about service and MUST HAVE
THE GOODS on time—there is ONE SAFE PLAN
MAKE BLACKMAN YOUR JOBBER

BLACKMAN TALKING MACHINE CO.

J. NEWCOMB BLACKMAN, Pres.

97 CHAMBERS ST., NEW YORK

VICTOR and EDISON Distributors



PLANNING FOR NEXT CONVENTION.

Entertainment Committee of Jobbers' Association is Whetting Appetites of Members with Booklets Descriptive of Exposition.

The arrangement committee of the National Association of Talking Machine Jobbers has already begun an active campaign for the purpose of insuring a large attendance at the 1915 convention of that body, to be held in San Francisco some time in July. Last week the committee sent out to association members several interesting illustrated booklets regarding the Panama-Pacific International Exposition, which will be under way in San Francisco at the time of the convention, in order to stir up early interest in the coming trip.

PROTEST ON DUTIES OVERRULED.

The Victor Talking Machine Co. protested the New York Customs Collector's assessment on mica washers, cut to size and finished for gramophones. Duty was taken at the rate of 45 per cent. ad

valorem under the provision for "parts of gramophones." The claim was for a tax of 1 cent per pound and 20 per cent. ad valorem as manufactures of mica.

The protest was overruled by the Board of General Appraisers.

BOOKED SOME BIG ORDERS.

T. F. Walsh, Secretary of Union Specialty & Plating Co. Tells of Good Times in the Trade—Many Specialties in Demand.

Among the visitors to the talking machine trade in this city during the past week was T. F. Walsh, secretary of the Union Specialty & Plating Co., Cleveland, O., who closed some very large orders for the various specialties relating to talking machines manufactured by this prominent establishment. He also made a general visit to the principal cities of the East, booking a satisfactory business. When seen by The World representative Mr. Walsh was very optimistic regarding business gen-

erally, and particularly buoyant over the outlook in the talking machine trade, which he declared was the least affected of any owing to the disturbed conditions created by the European war.

The Union Specialty & Plating Co. is constantly adding to its supplies for talking machine manufacturers and jobbers, and will have some important announcements to make in the near future.

LIVELY TRADE IN NEWARK, N. J.

Talking Machine Stores and Departments Enjoying a Most Satisfactory Holiday Business—Improvements in Hahne Department.

NEWARK, N. J., December 11.—One of the bright features of the holiday music trade in this city has been the satisfactory character of the talking machine business, practically every concern having a talking machine department is enjoying about all the business it can handle. The stocks of the dealers are in excellent shape and there is little prospect of a serious machine or record shortage before the holiday buying is over.

The talking machine department of Hahne & Co., under the direction of the Musical Instrument Sales Co., has been entirely rearranged and remodeled and four new sound-proof booths have been built for the accommodation of record purchasers. It is planned to make the department a strong factor in the trade in the very near future.

The Griffith Piano Co., which has the agency for the Edison disc phonographs, reports the sale of five high-priced machines of that type this week, with a number of excellent phonograph prospects in sight for Christmas purchases.

The Armstrong Piano Co., which handles the Victor line, is doing a lively business in that line and reports that the volume of sales during the present holiday season is greatly in excess of the record for the same season last year.

The Columbia Grafonola department of the F. G. Smith Piano Co. is very busy at present and it has been found that the use of the Grafonola and Columbia as the accompaniment to dancing on the floor above the store has proven of material assistance in influencing sales of both machines and dance records.

The talking machine departments of the Lauter Co., Steger & Sons and the Standard Piano Co. have proven very successful this fall and quite in contrast to some other lines of business. The higher priced machines, those of the cabinet type, have the preference in the majority of cases.

RECORD ALBUMS THAT PLEASE.

Holiday Season Brings Heavy Demand for Products of National Publishing Co.—Liberal Reorders and Testimonial Letters from Dealers Prove Satisfaction Giving Qualities.

The approach of the holidays and the stimulation of record sales has had an excellent effect on the demand for the line of record albums manufactured and marketed by the National Publishing Co., Philadelphia, Pa. The many dealers throughout the country who have already been handling the National albums are enthusiastic regarding their satisfaction giving qualities, including their durable construction and attractive appearance, combined with convenience. The National albums contain twelve or seventeen pockets and are made in two sizes to accommodate ten or twelve inch records. The pockets are so designed that the numbers and titles of both single and double-sided records are plainly visible, which makes the finding of any record desired a simple matter.

A feature of the policy of the National Publishing Co. that makes a strong appeal to retailers is the manner in which the company assists its dealers in making sales through the supplying of special circulars regarding the albums and other sales helps. The circulars are attractively printed, convincingly worded, show illustrations of the albums and are supplied in quantities to the dealers upon application. Selling hints are also supplied.

The fact that many dealers have not only written enthusiastic letters in praise of the National albums, but have also placed large reorders for those goods is the best proof of their satisfaction giving qualities.



Motion Pictures of Modern Dances with Phonograph Accompaniment

are the Greatest Business Builders ever offered to the

Talking Machine Dealer

Because they offer him not only the opportunity of

Increased Record Sales

but he can also

DOUBLE the profits of his business

through the combination of

Music and Movies

The *Pathéscope* is not only "The Companion Entertainer to the Talking Machine" but with Films illustrating the Modern Dances it can be best used in combination with the Talking Machine.

The PATHÉSCOPE CO. of America, Inc.

Dept. 7, Aeolian Hall New York

AGENCIES:—515 Crozer Bldg., Philadelphia. 1217 F St., Washington. 507 American Bldg., Baltimore. 459 Washington St., Buffalo. 108 6th St., Pittsburgh. 622 Kittredge Bldg., Denver. 1516 3d Ave., Seattle. 657 Leader News Bldg., Cleveland. 501 Dime Savings Bldg., Detroit. 14 W. Washington St., Chicago.

RESPONSIBLE REPRESENTATION DESIRED ELSEWHERE

An exceptional opportunity for Talking Machine Dealers to add a PATHÉSCOPE DEPARTMENT and FILM EXCHANGE, or for Enterprising Men with some capital to establish a Permanent and Profitable Business of their own. Write for Agents' Circular.

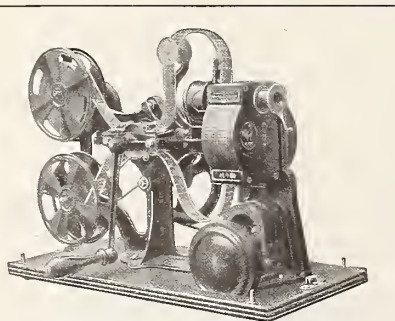

The First Safe, Simple and Perfect Home Motion Picture Machine. Complete with 4-foot Screen and all Accessories - \$150

Big Fire Will Cause Only Short Delay in Operation of Edison Plant.

Work of Rebuilding Factories in Orange Started on Morning Following Conflagration—
Thomas A. Edison Meets Disaster Courageously—An Optimistic Letter to the Trade—
Record Molds and Much Machinery Saved—Final Estimates of Actual Monetary Loss.

Orange, N. J., December 10, 1914.

Mr. Edward Lyman Bill,
Talking Machine World, New York City.

Dear Sir:—We thank you very much for your telegram expressing sympathy. Workmen and engineers are already busy clearing away the debris and planning repair work. It is the consensus of opinion that we shall be manufacturing phonographs and records in a surprisingly short space of time. Yours very truly,

C. H. Wilson,
Vice-President and Gen. Manager.

The destruction of a large portion of the great Edison plant at West Orange, N. J., by fire, on the night of December 9, was a distinct shock to the entire country, for not only talking machine representatives, but the entire world were interested in the great inventor and his creations, and will sympathize with him and his associates in the destruction of the great Edison plant.

While it is not definitely known just how the fire started, it is supposed that an explosion in the

the fire. There was also a small outside insurance.

The great inventor, with his wife and several friends, stood near a window on the fourth floor of the building across the street and saw the work of years wiped out by the flames. His first concern was for his laboratory, where scientific machinery of great value was installed and which contained all the Edison patents and records of all his works. Firemen kept more than a dozen streams of water playing on this building, while

West Orange citizens gathered to the extent of 12,000 near the scene of the fire, all desirous of helping the firemen. Sympathy for the famous inventor was universal in the great crowd which gathered. Hundreds of telegrams and letters from friends and business acquaintances reached Mr. Edison after the fire. They came from all over the country, and contained expressions of regret at his loss.

Naturally Edison representatives in every section of the country are deeply interested in the future plans of the Edison corporation; but, they can rest assured that no time will be lost in creating a newer and greater enterprise, and that every possible means will be used to facilitate the rehabilitation of the manufacturing enterprise.

Encouraging Letter to Dealers.

On Thursday morning, the day after the fire, the following optimistic and encouraging letter, signed by C. H. Wilson, vice-president and general manager of Thos. A. Edison, Inc., was sent to the trade



View of the Ruins of the Edison Plant Taken the Morning After the Fire.

film room, a one-story frame building, was the direct cause. At least an explosion was heard in that building before the flames were first seen.

The celluloid films burned with a rapidity and fierceness that sent tongues of flame through the windows of the cabinet works, a five-story, concrete building adjoining. In a short time that building was wrecked and the flames had spread to half a dozen other buildings.

The moving picture building in which all of the Edison photo plays were constructed and which contained films, cameras and motion picture apparatus of great value, was destroyed, not a single thing being saved of all its contents.

The storage building of the chemical works practically blew to pieces when the fire came in contact with the hundreds of pounds of chemicals stored there.

The other buildings destroyed included the plants of the Bates Numbering Machine Co., the Edison Diamond Disc Phonograph Works, the Edison Phonograph Cylinder Works, the Edison Primary Battery Works and the Blue Amberol Phonograph Works and the Administration building.

The monetary loss is very large. It is said that Mr. Edison will have to stand a loss of between \$3,000,000 and \$4,000,000. He carried his own insurance, a so-called blanket policy, whereby out of the yearly profits of the plant he has been putting away a certain percentage for fire risk. He explained that he has through that policy about \$2,000,000 to offset in part the damage caused by

others carried out all of its contents and stored them in the storage battery building across Lakeside avenue. Both these buildings were saved in their entirety.

The great inventor bore his loss bravely, his voice was cheerful and he smiled when reporters questioned him on the night of the fire.

"I'm pretty well burned out just now, boys," he said, "but I'll start all over to-morrow. There'll be some rapid mobilizing here when this debris cools off and is cleared away. I'll go right to work to build the plant over again. It is just a temporary setback; don't forget that.

"If anyone had told me yesterday that this block could be destroyed by fire," he exclaimed, "I would have considered that man crazy. But I'll wager that the new plant I'll build will be proof against everything but an earthquake."

Of the 3,700 employees who worked in the buildings that were destroyed, as many as possible will get work in the reconstruction.

"While the film-producing plant was wiped out entirely," said C. H. Maxwell, second vice-president of the Edison Corporation, "we still have a wooden auxiliary film building a short distance from the site of the fire.

"The phonograph works were destroyed entirely, and there will be a temporary stop to this branch of the Edison business. This business should be resumed in a very short time. Casts of records on which the voices of famous singers are recorded were saved, however."

and should serve to set at rest any fears entertained by jobbers and dealers regarding the ability to secure future supplies of machines and records. The letter reads:

"TO EDISON DISC DEALERS—We find that the fire is not as bad as first supposed. Most all our machinery is intact and will only have to be cleaned up. We are moving it into the storage battery buildings, which are nearly as large as those burned and just completed; also we are starting outside shops manufacturing the disc phonograph motors.

"As to records, we are not badly crippled and believe we shall be able to ship a monthly list January 1, and be in good shape thereafter.

"All orders on file are hereby cancelled. Do not ship to Orange any records, repair work or any material until you are advised we are ready to receive it.

"Shipments of advance supplemental lists of disc records, either on hand or en route, may be placed on sale immediately.

"Assuring you that we shall work day and night to put things into shape again, we are.

"Yours very truly,
"THOS. A. EDISON, INC."

Some men climb the ladder of success. Others hold it. It's largely a matter of initiative—or the lack of it.

No harvest of success was ever reaped from a sowing of wild oats.

COLUMBIA

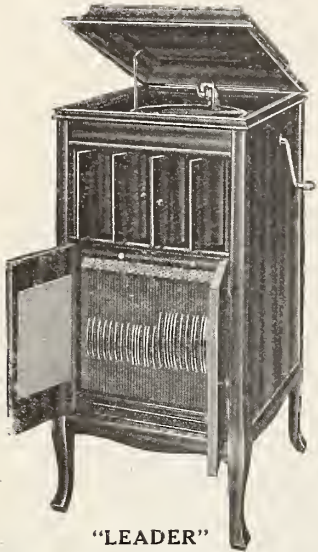

"LEADER"

With Columbia Individual Record Ejector
\$85

Mahogany, Quartered Golden Oak or
Satin Walnut.
With Record Racks
\$75
Mahogany, Satin Walnut or Quartered Oak
(Golden Fumed or Early English).

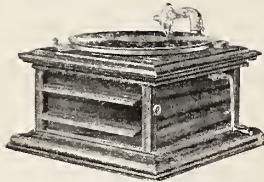

"ECLIPSE"
\$25

Mahogany or Quartered Golden Oak.

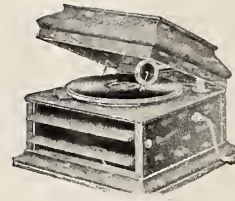

"JEWEL"
\$35

Quartered Golden Oak.

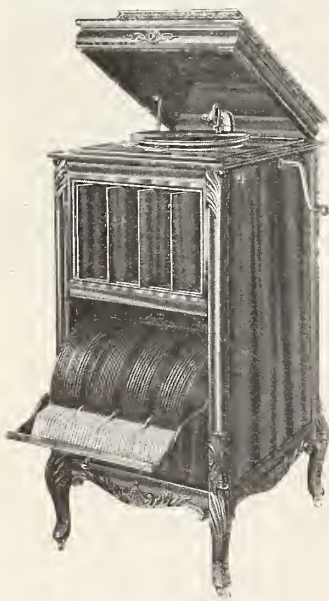
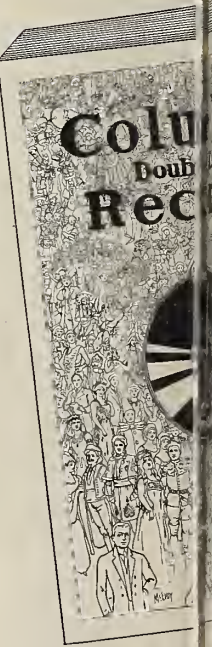
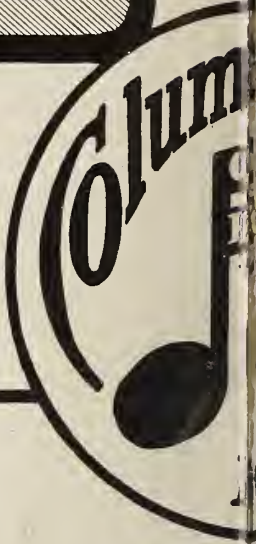

"MIGNONETTE"
\$100

Mahogany, Satin Walnut or Quartered Oak
(Golden Fumed or Early English).

FOR profit, prestige and publicity, Columbia product is the one best musical line you can couple up with your business for the year of 1915.

No industry in the world has ever shown the tremendous advance in quality of product and commercial development that has been achieved in this business.

It is quality of product that is the foundation of our constant growth. It is quality of product that always will be the keystone of our future development. We give bigger values in Columbia product by actual comparison than any other line in the trade. Machine for machine, record for record, Columbia product gives the consumer a higher intrinsic value on every dollar he spends.

Columbia Grapho-

WOOLWORTH BUILDING, N. Y.



"REGENT"
\$225

Mahogany, with carved legs. Quartered Golden Oak, Fumed Oak, or Early English Oak, with straight legs.



"IMPROVED CHAMPION"
\$25

Type BN, Quartered Oak.



"IMPROVED STERLING"
\$60

Type BII—Quartered Oak.

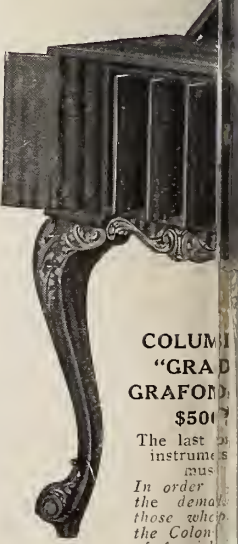

COLUMBIA
"GRAND"
GRAFONOL
\$500

The last of instruments musical
In order the demand those who the Columbia of furnish have provided the Columbia "Grand" in onola in nial design

COLUMBIA

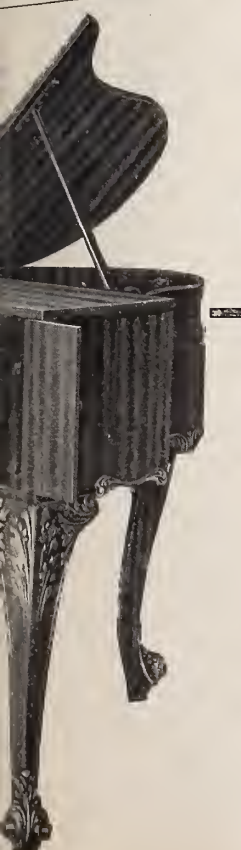

"FAVORITE"
\$50
Mahogany or Quartered Oak
(Golden Fumed or Early English).



"METEOR"
\$17.50
Quartered Golden Oak.

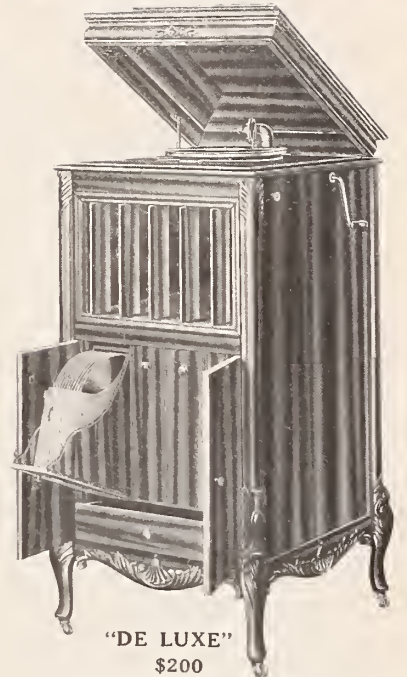

"DE LUXE"
\$200
Mahogany or Quartered Oak (Golden Fumed or Early English).

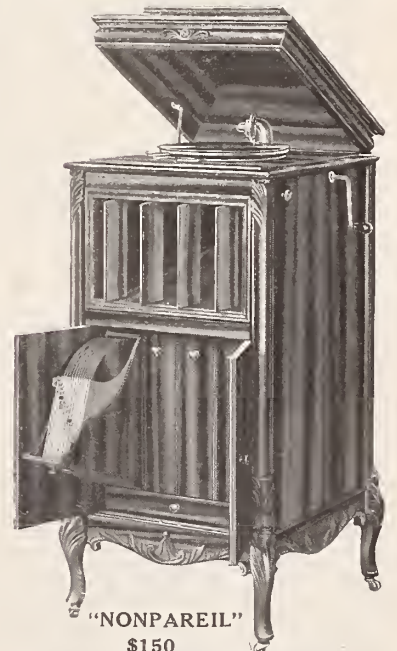

"NONPAREIL"
\$150
Mahogany or Quartered Oak (Golden Fumed or Early English).



"BABY REGENT"
\$100
Mahogany or Quartered Oak
(Golden Fumed or Early English).

THE price range on Columbia double-disc records is absolutely complete.

The standard price of 65c. on regular 10-inch double-disc Columbia records, two selections, one on each side, is a trade attractor that is adding thousands of record buyers as often as we issue a new record.

This is not the place to discuss the actual *figures* of the margin of profit, but we can assure you that we realize just as you do that the principal feature of successful *selling* is successful *buying* and we are prepared to go into full particulars with any dealer who will put a little of his time against a little of ours. We will agree to make the conversation interesting.

phone Company

Creators of the talking machine industry. Pioneers and leaders in the talking machine art. Owners of the fundamental patents. Dealers and prospective dealers, write for a confidential letter and a free copy of our book, "MUSIC MONEY."



"PREMIER"
\$50
Type BNWM Mahogany.



"IMPROVED ROYAL"
\$35
Type BNW Quartered Oak.

TIMELY BUSINESS POINTERS.

**Employers Taking Counsel with Employes—
The Knocker—Value of Tact to Salesmen—
Importance of the Correspondence Department—
Some Practical Suggestions.**

Invariably in a large concern we will find salesmen bright enough to sell goods and smart enough to meet objections; wise enough when dealing with a hard customer to know when a psychological moment is at hand.

This being the case, don't you think that people bright enough to work for your interest are bright enough to help you make plans? Don't you think you would gain valuable ideas in talking matters over with them?

This does not necessarily mean that you must pass from one employe to another in business hours. That hardly is what one would call a conference, but there should be a stated time, either weekly, monthly or semi-annually, just so that you got the selling force or clerical force, or whatever it may be, together.

Where the proprietor or manager does the "bossing" it is physically impossible for him to come in contact with all customers. Even in shops where the man at the head waits on trade there are only just so many customers that he is able to see personally, when, no doubt, he perhaps gets a few ideas from these customers as to what line of stock his trade would like.

Taking it for granted that he does, it is easily figured what the concentration of effort in this direction would mean. Talks with the selling force would not necessarily be held with the idea of just increasing the trade, but, on the other hand, to discuss general conditions and the merchandise to be handled.

A successful proprietor or manager of to-day is a man who has a keen knowledge of human nature and knows the shortcomings of his men.

Nearly every store has a "knocker." Some employes do not go to the manager with the grievance, but spread discontent by talking of their fancied wrongs to some fellow employe. Consul-

tation meetings or conferences at stated periods will eliminate this "knocking."

Tact should be primarily the essential qualification of all salesmen. It is unwise to depend upon having your merchandise sold by people lacking this virtue.

The salesman who is always polite and personally telling you what you want is one of the worst offenders against tact. He is the one who evidently does not believe you are able to do your own thinking, or the one who insists on selling you the entire stock when your intentions are to make some small purchase.

Salespeople should be tactful, indulgent, active, alert and polite, thoroughly posted on the merchandise they are handling and absolutely loyal to the house. They are the agents who, from the nature of their positions, help the success or the failure of the business in their keeping, as they are in immediate touch with the customer.

If any department is not a paying proposition it is not necessary to wait for inventory day to correct any existing evils. It can be done at once, thus putting the department on a profitable basis and taking no chance of an unprofitable department hindering the growth of the entire business.

Any man's success is due to his ability to organize. If he cannot bring system to bear he is to be likened to a man in a rowboat, not many feet from shore, without any means of propelling it.

The correspondence department is important, as prompt responses must be the keynote of this department. A dilatory answer is the worst form of advertising a house could have. This department requires a thorough knowledge of business principles, as well as high diplomacy and good judgment in their application. Nothing should ever be put in a letter which in any way will reflect on the house. While the letter is intended for one person, we cannot tell how many might chance to see it.

The man who can make the recipient of his letter feel that he is actually taking an interest in the matter in question is a valuable asset to the house.

MAKING PROGRESS IN THE TRADE.

Sonora Phonograph Corporation Adding New Dealers to Its Lists Steadily—The Country Well Covered—Demand Creating Policy Pays—Some Attractive Types of Machines.

The Sonora Phonograph Corporation, 57 Reade street, New York, of which George E. Brightson is president, has met with flattering success under its business policy, closely adhered to, wherein the demand for the products of the company is created before dealers are appointed to meet that demand. The result is that the new dealers have something tangible to work on from the start and are thoroughly appreciative of the company's methods. Several new traveling representatives have been added to the Sonora staff and new dealers are being signed up at frequent intervals and in all sections of the country. Only recently the Sonora Co., of San Francisco, was incorporated in order that the trade on the Pacific Coast might be looked after properly.

The Sonora line ranges in price from \$35 for the "Jewel" model to \$200 for the "Grand." There is also a Sonora at \$40, called the "Jewel Combination"; one at \$50, termed the "Excelsior"; the "Peerless," at \$75; the "Imperial," at \$100; the "Baby Grand," at \$125, while for \$150 two models are offered, the "Elite" and the "Rosary." In addition, the company also markets three special needles, the "Jewel" multi-playing, at \$1; the Sapphire for French records, at \$1, and the diamond-point needle for Edison, at \$5.

Considering the specifications of the Sonora, take the style "Grand," for example. It has a 12-inch turntable, extra heavy double-spring motor, playing half an hour, or ten 10-inch records in one winding. Has a tone modifier, sapphire needle, diamond needle and multi-playing needle, this equipment being all that is required to play all makes of disc records. Has automatic starter and stopper. Trimmings gold-plated. Envelope filing system has capacity for holding 160 records.

In the company's advertisement on the back cover of the World this month are illustrated four of the popular models, with their specifications.

Going back to the selling policy of the company, it is interesting to note that exclusive territory goes with each accepted agency, the purpose of this being to permit the dealer to reap all the profits that he can. This is a feature of sales distribution that is being widely discussed to-day, and this phase of Sonora exploitative work secures ready indorsement.

NEW INCORPORATIONS.

Among the incorporations relating to talking machines filed at Albany the past week were the following:

Union Talking Machine Co., Manhattan, manufacture phonographs, accessories, musical instruments, etc.; \$5,000; Nathan Smith, Marie Zaconick, Ida G. Jakowsky; attorney, H. H. Servis, Rochester.

Artrecord Corporation, publishing reproduction of sound, capital no par value; J. T. Norris, Jr., H. Harold Gumm, H. Von Tilzer, 125 West Forty-third street.

The Master Talking Machine Co. was incorporated in Delaware for the manufacture and sale of talking machines; capital, \$500,000. Incorporators: S. S. Adams, Jr., J. G. Gray, M. B. F. Hawkins, Wilmington.

TRY THIS ON YOUR PHONOGRAPH.

(There is entirely too much "He said" and "She said" in modern fiction, some critic has remarked. We will correct that right away. For example:)

"I'm here," he burred.

"I see," she gloomed.

"I've come for my answer. What is it?" he boomed.

"It's the same," she sniggled.

"Take it back," he replied.

"I want no old answers." "Do without, then." she sighed.

"That WON'T do," he blasted.

"Do you love me?" hissed he.

"I dunno," she sighed, "I've done forgot. See?"

A Merry Christmas and A Happy New Year TO ALL OUR DEALERS

WE SINCERELY TRUST THAT YOUR BUSINESS FOR
DECEMBER WILL BREAK ALL RECORDS AND THAT
IT WILL FOLLOW YOU INTO 1915.

WE HAVE ENDEAVORED TO KEEP YOUR WANTS
SUPPLIED DURING THE RUSH, AND APPRECIATE
YOUR CO-OPERATION IN MAKING THIS THE BIGGEST
YEAR IN OUR HISTORY.

YOURS FOR SERVICE

AMERICAN TALKING MACHINE CO.

368 LIVINGSTON STREET

BROOKLYN, N. Y.

CONVINCING ARGUMENT FOR HIGH CLASS RECORDS.

A "Telephone Conversation" from the "Voice of the Victor" That Served to Give a Doubtful Dealer New Ideas to Think About Regarding the Featuring of the Better Class of Records and Their Profit-Making Possibilities—Value of Quality Goods.

The demand for high-class talking machine records is growing apace throughout the country despite the immense demand for the more popular song and dance numbers of the day. Dealers should make it a point in the development of their record business to emphasize the importance of every purchaser having a number of standard songs and instrumental numbers in their record libraries. It serves the good purpose of widening musical appreciation—a field in which the talking machine has played and is playing a most important part in this country.

A rather suggestive "telephone talk" was that which appeared recently in "The Voice of the Victor," in which the editor tells of a three-minute chat with a dealer who became a better one as the result of this rapid-fire interview. The talk follows:

(Voice over the 'phone) Hello—hello! This THE VOICE OF THE VICTOR?

Yes. Who is it?

A. Victor Dealer.

Oh, yes, Mr. Dealer. What can I do for you?

Say, give me the dope on this high-brow stuff, will you?

Gladly, if you will tell me what your difficulty is.

Well, it's this way. I can't see this classical music when there's twice as much demand for the popular.

Now look here, old man, you can't see the back of your head, for that matter, but it's there, and it serves a very good purpose.

Quit your kidding, now—I'm asking for information!

FOR SALE

5,000 brand new 10-inch discs, English songs and musical selections. Must be sold at once, 10c. each. Berliner Phonograph Co., 140 East Fourth street, New York.

VICTOR BUSINESS FOR SALE

Retail Victor store with sporting goods in connection in Greater New York. Exclusive large wealthy territory. Annual sales about \$25,000 and steadily increasing. About \$9,000 required. Good reason for selling. Address Box 44, Talking Machine World, 373 Fourth avenue, New York.

WANTED—POSITION

Position wanted as manager of wholesale talking machine department; 15 years' experience. Would take charge from buying to shipping. All around worker. Am also expert repairer of machines. Correspondence invited first instance. Address, Box 300, Talking Machine World, 373 Fourth avenue, New York.

WILL BUY

Job lot of talking machine records. Also second-hand and shop-worn records purchased. Address Talking Machine Exchange, 66 Halsey street, Newark, N. J.

FOR SALE

Victor talking machine store, the best in the city. Large established trade. This year's profits over \$5,000. Will sell at inventory, nothing for good-will. For particulars, address Jacobs, 2131 North Seventh street, Philadelphia, Pa.

FOR SALE

5,000 single-face, 10-inch Columbia disc records, guaranteed brand new; price, 9c. each. A bargain for a wise buyer. Deninger Cycle Co., Rochester, N. Y.

WANTED

To exchange \$2,000 clean jewelry stock for phonograph stock, Edison, Victor or Columbia. Address W. M. Lefavor, Avalon, Cal.

Well, I'll give it to you, but I admit I'm a little touchy on this subject.

That's all right, old sport, but here's the idea: "Too Much Mustard" is a fifty-to-one shot with me as compared with the Prologue from Pagliacci.

Now, you're exaggerating, and you know it!

Well, a little, maybe; but you know what I mean.

I hope to thunder you don't mean what you say, because it's sheer craziness.

Well, all right, but WHY is it?

My dear man, if you were in the dry goods business would you refuse to stock silk because most of the trade ran to calico?

No, of course not; but that's different!

It isn't—it's the very same thing. Better-class goods seldom have as big a demand, bulk for bulk, as the cheaper ones, but they have to be carried in stock. A department store, or any other store for that matter, that was unable to supply quality goods would be recognized at once as a "cheap" house. Do you want that reputation?

Don't get fresh, now. I can see all that plainly enough, but you haven't answered my question yet. I'm in business to make money!

You are? Then you are going the wrong way about it!

Can't see it. Can't see it with a spyglass. You admit that better-class goods don't have as big a demand in any line, don't you?

Yes, I've just said so.

Then you say that the better-class goods have to be carried in stock. Now what I want to know is, WHY?

The answer is: Because you'll never build up a big, a profitable and a solid business except on quality goods.

How do you figure that out?

The man who simply uses a Victrola for a moment's pleasure is essentially a "transient" customer. For such people any band, any singer, indeed, any machine will do.

So you think—

I don't think, I KNOW. The man who likes music—if he's given a chance—soon gets to liking good music. The man who likes good music soon gets over the "liking" stage. He gets "nutty" over it. He wants music, and more music. He wants it by the best singers available. He is no longer content just to listen, but he begins to observe just how this, that and the other artist gets his or her effects. Now which type of man is going to help you build up a steady business?

Well, I guess there's something in that, all right.

Of course there is. There are lots of people who like to sit and listen to music, just as they like to sit in a hot bath, but if you don't help them to get beyond that point you won't be able to consider them steady customers for very long.

Say, hold on; hold on! Enough's enough! I quit. Call me a boob if you want to.

Get out, old man. I know you too well. Come out and play a game of golf with me on Saturday. Your "batting eye" is off color, that's all that's the matter with you.

Well, I guess you're right, all right. Got anything particular to suggest?

Of course, but you'll have to tell me just where you get stuck—only tell me some other time.

Busy, I suppose?

Yes, very.

Well, don't blame me. I haven't said a word and you've nearly talked the arm off me; however, I don't hold a grudge long, so here goes.

JOINS EDISON SALES FORCE.

George Chittenden Turner has recently joined the Edison sales force to represent the Edison phonograph products. For the present Mr. Turner will devote himself to Edison interests in New York and Brooklyn.

A

Merry Christmas

and a

Happy New Year

to all

Victor Dealers

WE hope that all our Victor dealers are satisfied with our service and we herewith acknowledge our appreciation.

At Your Service
for 1915 to 50
additional Victor
dealers only.

"A limited number of
dealers served well is
a very good policy as
our dealers can tell."

Landay
BROS. INC.

Victor Distributors
Exclusively

563 5th Avenue
NEW YORK

AEOLIAN-VOCALION ANNOUNCED.

Latest Product, a New Type of Talking Machine, Put on the Market by the Aeolian Co., the Prominent Piano Manufacturers and Retailers—Some Interesting Features of the New Line of Instruments.

The following interesting announcement was mailed recently by the Aeolian Co. the piano manufacturers of New York, to its stockholders:

ANNOUNCEMENT TO STOCKHOLDERS.

"Monday, November 23, will mark the opening of the Vocalion department at Aeolian Hall. This should be an event of the greatest interest to every stockholder, for the Aeolian-Vocalion is a new departure, and its introduction to the public opens a new epoch in Aeolian development.

"The executive officers of the company sincerely hope that the stockholders will make themselves familiar with this remarkable new musical instrument which they have had a share in giving to the world, and that they may employ their every influence to aid the management in making the Aeolian-Vocalion the greatest success in the history of the company.

"It is suggested that the opening day affords an opportune occasion for a visit to the Vocalion department, and to become acquainted with the newest and most wonderful phonograph.

"THE AEOLIAN CO."

This brief announcement was the first official intimation on the part of the Aeolian organization that the company was preparing to enter in a large way upon the manufacture of phonographs, or Aeolian-Vocalions, as the new type of instrument will be called.

Those responding to the invitation found awaiting them a line of phonographs in mahogany cases ranging in price from \$90 to \$375. There were various features about the new instruments that attracted attention, but probably the one that drew the greatest interest was the Graduola. This is a device built into the fundamental mechanism of each Aeolian-Vocalion, by means of which the volume of tone may be kept entirely under the control of the listener, if he so desires. To operate the Graduola there is a flexible control tipped with a valve. This permits the listener to sit some distance away from the instrument while he decreases or amplifies the volume of tone to suit his own interpretation of the selection being played.

The Aeolian Co. owns the Graduola patents, having purchased them nearly two years ago from the Australian inventor—F. J. Empson.

Although the Graduola is perhaps the most striking innovation in the new line, there is bound to be much interest in the tonal qualities of the Aeolian-Vocalion. The company states that experimentation looking to a perfect type of phonograph has been under way in its laboratories and factories for over two years. Elaborate investigations have been made in connection with sound box, tone-arm and horn, and several important discoveries have been incorporated in the new instruments. In the opinion of the Aeolian Co. a

distinctive type of phonograph has been produced in the Aeolian-Vocalion.

There will be a public announcement made later in reference to these new features, the company contenting itself at present with a general announcement as outlined in its invitation to the stockholders.

The various types of instruments now being exhibited are only a small part of the full line in process of development. No attempt will be made until later to supply the company's agencies over the country, although instruments are being sold to stockholders and some of the New York City customers.

COLUMBIA MANAGERIAL CHANGES.

R. F. Bolton Becomes District Manager for New York City and Upper Part of State—S. H. Nichols' Important Territory—I. F. Bradt Joins Executive Staff.

The Columbia Graphophone Co. announced last week a number of promotions and appointments in its executive and managerial staff, which supplement the appointment of John A. B. Cromelin to the office of general manager of the company.

R. F. Bolton, manager of the Columbia Co.'s wholesale headquarters at 89 Chambers street, New York, and connected with the company for many years, has been appointed district manager of New York territory, including the Buffalo and Rochester district. Seth H. Nichols, manager of the Pittsburgh wholesale headquarters of the Columbia Co., has also been appointed district manager, his territory to include Cincinnati, Cleveland and Toledo in addition to his present territory. James P. Bradt, who at one time held important managerial posts with the Columbia Co., having been manager of the Canadian business and London and Berlin manager, has joined the executive offices of the company, to perform special duties.

THE CRESCENT TALKING MACHINE

One of the Latest Additions to the Lines of Machines Now on the Market, Makes Excellent Impression—One of the Popular Styles.

One of the latest talking machines to be presented to the trade of this country is the "Crescent" talking machine, manufactured by the Crescent Talking Machine Co., Inc., 99 Chambers St., New York. The style illustrated herewith is known as model No. 10, the retail price of which is \$40, exclusive of the albums. Dimensions are: height, 36 inches; width, 16 inches, and depth, 16 inches. Furnished with or without diamond point.

Since its introduction, the officers of the company report that a number of agencies have been placed about the country, the latter being continually increasing as a result of the distributive work that is going on.

Among the selling arguments advanced are the following special features, which are taken direct from the literature issued by the Crescent Co. "Crescent machines are equipped with an improved tone-arm, with friction reduced to a minimum, and

contain other novel features, among them being the 'universal tube,' which makes it possible to change from steel needle to diamond point record by a mere turn of the sound box. The Crescent will play any type of record, including those for diamond or sapphire point. A portion of the front of the cabinet, hinging outward, forms a prolongation for the horn, throws the sound upward—to hearing height—and leaves an unimpeded passage for the sound. When closed, it protects the interior from dust and leaves an ornamental, useful table, when not in operation as a phonograph."

Materials for the manufacture of the cabinets are

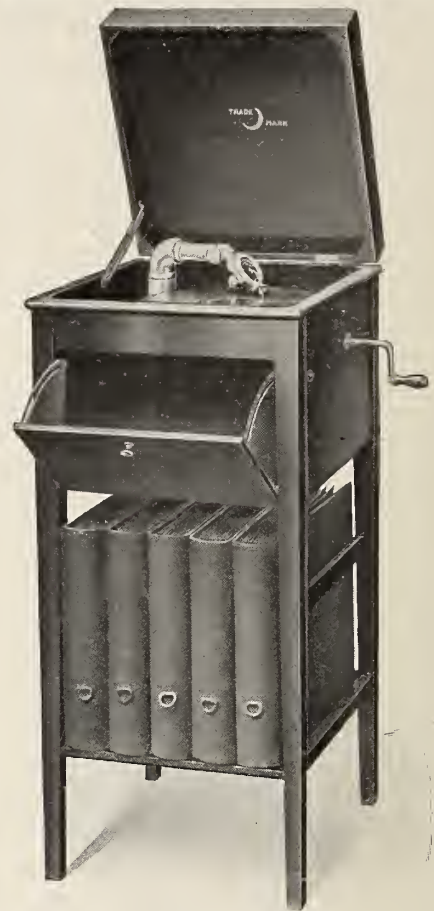

Model No. 10.

carefully selected and the finish of the cabinet is considered to be of high quality. The motor is produced under specifications from the Crescent Co., and is made specifically for this model. Other types quite as attractive at their respective price list at \$12.50, \$15, \$150 and \$200.

The Columbia Co. has closed arrangements with the May Furniture Co., Columbus, O., whereby this house will handle the complete Columbia line and give it forceful representation in this important territory.

The Riggins Piano Co., well-known throughout southern New Jersey as a representative piano house, with headquarters at Bridgeton, has recently taken on the Edison disc line.

TO VICTOR AND COLUMBIA DEALERS

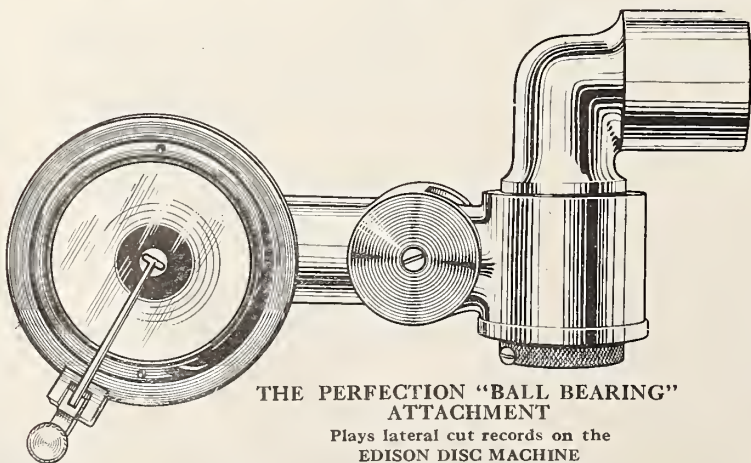

THE PERFECTION "BALL BEARING" ATTACHMENT
Plays lateral cut records on the EDISON DISC MACHINE

Do you want to sell records to owners of EDISON DIAMOND DISC MACHINES? If you do, carry our "PERFECTION" attachment in stock.

EDISON DISC MACHINE owners will be coming to you every day asking you if the records you sell can be played on their machines. If you carry our attachments in stock you not only have a chance to sell them, but you also have a chance to make record sales and add a new name to your record mailing list.

We can also furnish you with a reproducer which is fitted to our attachment. Price of sample attachment, \$2.50 in gold, nickel, or bronze finish. With reproducer any finish \$4.75. Cash or check must accompany each order for sample. We will quote you quantity price on cash or credit basis on request.

EVERY PHONOGRAPH DEALER IN THE UNITED STATES AND CANADA SHOULD STOCK THIS ATTACHMENT.

If you are interested write to us and we shall be pleased to give you our view of its present and future value.

NEW ENGLAND TALKING MACHINE CO.
132 Boylston Street
BOSTON, MASS.



If you will make careful comparison you will find that the length of Columbia prices will bring you closer to more varieties of profit than any other line on the market.



(Write for "Music Money," a book "full of meat" for those dealers interested in quick and frequent turnover of capital.)

Columbia Graphophone Company
Woolworth Building, New York

CO-OPERATION WITH THE DEALER.

The Jobber Who Desires to Win Success Must Adopt This Policy, Says Wm. W. Gibson, Manager of the McKee Surgical Instrument Co., in Discussing the Entrance of His House Into the Talking Machine Field.

William Wilson Gibson, manager of the Baltimore, Md., headquarters of the McKee Surgical Instrument Co., Washington, D. C., and Baltimore, Edison disc and cylinder jobbers, in a recent issue of the Edison Phonograph Monthly, tells of the entrance of his house in the phonograph business, and gives some fundamental rules for the success of a jobber. He said in part:

"If a jobber is to be successful, he must learn to co-operate with every dealer who buys from him. After all is said and done, if the spirit of helpfulness does not exist between jobber and dealer, there is no hope of real success on either side.

"First of all a jobber must be thoroughly familiar with his line. He must be able to answer any question that a dealer may ask. If the jobber can truly be an 'information bureau,' he will not only help his dealers, but also himself, as the dealers will want to patronize the one who can render them the best service.

"Again, a jobber must be up to the minute in every particular as regards new records, new equipment, advertising, literature, etc.; must keep his dealers supplied with all available helps that he can. In order that this may work satisfactorily, dealers must make their wants known from time to time.

"In the third place, a jobber must carry a complete stock of everything pertaining to his line. There must not be any delays in filling orders, if the jobber would hold his customers' trade. If a dealer wants a certain record or part, he wants it bad, and if his jobber cannot send it out the day he receives his dealer's order, that jobber cannot hope to retain the dealer's good will.

"Again, a jobber must be full of original ideas for increasing the trade of his dealers. He must give suggestions for increased retail sales if he wants his own wholesale business to grow.

"The jobber is the connecting link between the manufacturer and the dealer. He is a very necessary adjunct to the success of the business, as no manufacturers could begin to keep in touch with every dealer located in all corners of this vast country. As long as our line of business lasts there must be jobbers, and as long as these jobbers act honorably with their dealers, so long will they remain in business.

"There is one way in which a dealer must help his jobber, and that is by paying all of his debts promptly. It costs a great deal for a jobber to carry a large and complete stock, and if the dealers won't pay, either one or the other will have to suffer."

INCREASES CAPITAL STOCK.

The Scott Automatic Phonograph Co., Los Angeles, Cal., has increased its capital stock from \$100,000 to \$1,000,000.

ARTIST PRAISES ARTIST.

Maud Powell Praises Kreisler's Recital of Wieniawski's Famous "Légende."

Maud Powell had a most important article in the October Etude, analyzing Wieniawski's famous "Légende." In her preliminary remarks she touches on the subject of tempo rubato, saying, among other things of exceeding interest to teachers and students:

"Let every violin student listen to Kreisler's sound reproducing machine record of the Bach E major Gavotte if he wants to learn what playing in time is. As for rhythm there is no better example extant. I may say right here that Kreisler is our greatest violinist for refined delicate artistry, exquisite and precious, and yet Kreisler in some of his best interpretations scarcely deviates from the tempo except in the subtlest manner possible. The elasticity of Ysaye's tempo and the master's sentimentalizing of the melodic line (rhythmically), while justifiable in Ysaye, the mighty, are not the best models for the student. Elman also is an un-

safe model for the inexperienced to follow, inasmuch as too much emotionalism will inevitably swamp the technically inadequate student. We are young in this country, very young, artistically, so that in our artistic beginnings we must copy those models which have the seal of severe test. There is a chastity combined with exuberant health that one must seek in art as well as in life."

VICTOR NUMERICAL CATALOG.

The Victor Talking Machine Co. sent out to its dealers last week the annual numerical catalog of Victor records. This catalog is similar to previous editions of this important publication, containing extra pages for pasting in the new records issued every month, together with a page of valuable suggestions on how to keep track of record stock.

Many a man's ship never "came in" because it was submarined by an overlooked opportunity.

It's the man with the single-track mind who has collisions with mistaken trains of thought.

READ = WHAT THE TALKING MACHINE WORLD SAYS ABOUT THE "OGDEN" SECTIONAL RECORD AND FILING SYSTEM

SECTIONAL RECORD CABINETS.
Ogden System of Record Filing Proves Most Convenient for Dealers—Cabinets That Grow as Needed—Signal System That Makes It Easy to Find Records—Other Advantages.

A talking machine accessory that is continually making new friends among talking machine dealers is the "Ogden" sectional record cabinet, made and marketed by J. B. Ogden, Lynchburg, Va. One of the chief advantages of the Ogden filing system is the fact that, being built on the order of the sectional bookcases that have long been familiar to the public, it has all the advantages of those pieces of furniture combined with a number of original features for this particular trade. The original idea attracts owing to the fact that, as the record library grows, it is possible to add sections after section without having waste cabinet space in evidence or several records placed about the room. The cabinets are supplied with special top and bottom parts, and from one to four or more sections may be added at will, without having the effect of being a single and complete piece of furniture.

A special feature of the Ogden cabinets that appeals particularly original in character, and which makes it a simple matter to find any desired record in a few seconds. A drawer in the base of the cabinet is also equipped with an automatic reordering system that serves to aid the dealer materially in keeping his stock up to date. There are many other features of the Ogden sectional record filing cabinet worth knowing about.

EFFECTIVE DEALER PUBLICITY.

Write for catalog giving name of your jobber.

J. B. OGDEN
Lynchburg, Va.

Guaranteed

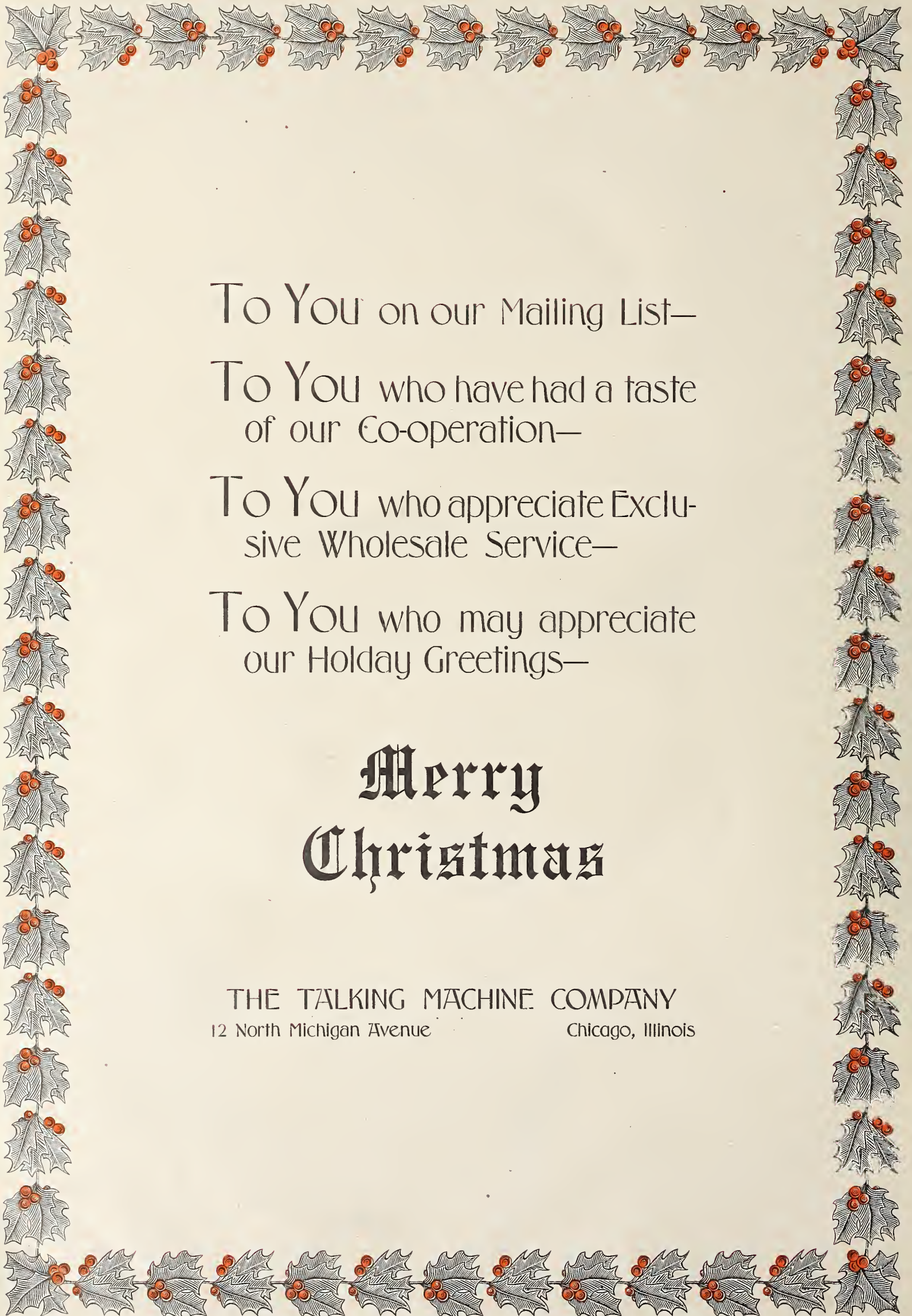

To You on our Mailing List—
To You who have had a taste
of our Co-operation—
To You who appreciate Exclu-
sive Wholesale Service—
To You who may appreciate
our Holiday Greetings—

Merry Christmas

THE TALKING MACHINE COMPANY
12 North Michigan Avenue Chicago, Illinois

FROM OUR CHICAGO HEADQUARTERS

E. P. VAN HARLINGEN, Manager
HENRY S. KINGWILL, Associate

World Office
Consumers' Bldg. 220 South State St., Chicago
Telephone: Wabash 5774

(Special to The Talking Machine World.)

CHICAGO, ILL., December 11.—The talking machine trade of Chicago and the Middle West is doing what can safely be said to be the very best Christmas season in history, and this despite the general depression that exists in so many other lines of business.

This optimism exists in a greater degree in the smaller communities, where the industrial depression is more psychological than in the big cities. Speaking generally, the main difficulty seems to lie in the difficulty of securing machines, all jobbers reporting a big deficiency and an especial shortage in instruments priced around \$100. The public seems to have been impressed with the work of the manufacturers on machines at this price and almost every dealer has calls for these machines, and is, unfortunately, unable to supply them.

Some excellent advertising has been done by the large manufacturers, both Edison and Columbia being prominently exploited early in the season and a big Victor campaign being carried on at the present time.

Dance at the Edison Shop.

One of the most novel dancing exhibitions that has yet been given was presented this week at the warerooms of the Phonograph Co., the local Edison dealers and distributors. The dancers were Miss Edna Neill and Mr. Farnsworth Frick, who demonstrated the new and very popular step known as the "Rouli-Rouli." The crowd in attendance was a very large one, according to General Manager C. E. Goodwin, and the receipts on the day's sales were likewise very big.

In this connection Mr. Goodwin made the statement that present indications pointed to a Christmas season at least twice as good as that of last year. Mr. Goodwin adds further that despite the disastrous fire at the factory the stock is sufficient to last, as a very generous supply was received some time ago in Chicago.

Some of the Good Sellers.

The five most popular selling records of the Edison library this month appear to be a violin number, "Ave Maria," as played by Carl Flesch; "Toreador Song" from "Carmen," sung by Thomas Chalmers; "I'll Take You Home Again, Kathleen," tenor solo by Van Brunst; "Dixie Medley," a banjo number, and "It's a Long, Long Way to Tipperary."

Five Columbia records that are selling well are "Cohen on the 'Phone," "It's a Long, Long Way to Tipperary," "Dreamy Chinatown," "Ballin' the Jack" and "When It's Night Time Down in Burgundy."

Of the Victor records five of those that are in demand, together with selections on the reverse side, are "Whispering Hope," "Stille Nacht, Heilige Nacht," "Little Gray Home in the West," "Tipperary" and "Cecile."

Enlarge Lyon & Healy Office.

The wholesale rooms of the talking machine department of Lyon & Healy's have been considerably enlarged and a new private office has been built for Manager L. C. Wiswell in a location adjacent to the retail record department. Mr. Wiswell reports an exceptionally heavy volume of business. There has also been a large volume of Christmas business already transacted in the retail machine department. This has necessitated the additional help of several new salespeople, including H. B. Barnes.

D. C. Preston at New Post.

D. C. Preston, formerly representative of the Talking Machine Co. in Wisconsin and Iowa, has been selected as manager of the Victor department of the L. S. Donaldson Co., of Minneapolis. The opening of this new section of the big Minneapolis institution was featured by a dancing exhibition by Miss Helen Maxwell and Kenneth McKenzie, who came from Chicago for the occasion. The dances were given in the Tea Room adjoining the Victor department and were very well received by a large crowd of people. Mr. Preston was assisted in the opening by G. P. Ellis, of the Talking Machine Co., of Chicago.

Mr. Preston will be succeeded in the Talking Machine Co. by A. M. Lockridge, an experienced salesman, who has been spending considerable time in going through the instruction course, which consists of a period of time spent in the repair department, stock rooms, sales department and the sales floor.

Some Excellent Sales Supplements.

The Talking Machine Co. this year followed its regular custom of supplying its patrons with a number of supplementary sales ideas in anticipation of the Christmas season. Among them were a "\$10 gift list," a "\$25 gift list" and a complete "Christmas record list." The Christmas boxes are

covered with holly and poinsettia decorated paper and other articles designed to stimulate Christmas sales.

Sales Manager Roy J. Keith has received a generous response to this outlay of sales literature and says that the dealers have shown every sign of appreciating them.

Visited the Victor Plant.

Fred Siemon, manager of the talking machine department of the Chicago house of Wurlitzer, was one of the visitors to the Victor plant at Camden recently. Mr. Siemon reports that while he was there the factory was working both day and night shifts.

Attractive Wurlitzer Window.

Ellis B. Hansen, of the Wurlitzer Co., has been showing an especially attractive talking machine window recently. The window contained a miniature opera house with a stage reproduced in detail. The curtain rose and fell automatically upon well-known scenes from several different operas. The staging and lighting effects were especially good and a large crowd was in constant attendance before the unique display.

Geo. P. Bent Co. Opening.

The opening of the remodeled retail department of the George P. Bent Co. was held Saturday, December 12. The reconstructed warerooms have been very beautifully designed and finished and form one of the most attractive institutions of its kind in Chicago. The Cheney and Victor lines were prominently displayed and received much exploitation. The following is an extract from the newspaper announcement:

"We are proud of the new setting of this department, because its facilities, its appointments and its scope are such as to make 'shopping' a genuine pleasure to our many patrons and to the great Chicago public. * * * Not only have we provided every convenience for the quiet and refined demonstration of machines and records—not only do we carry one of the largest and most complete stocks in the city, but we have also a courteous and efficient sales organization. Here the counsel of salespeople, who are well versed in the mechanical construction of talking machines as well as in the repertoire of the Victrola, is at your free and unlimited command. We will celebrate the opening of these new ground floor quarters tomorrow with a genuine "house-warming," to which you are cordially invited. There will be tea and flowers, as well as an enjoyable series of select

(Continued on page 37.)

THE WADE—THE PRACTICAL—THE WADE Fibre Needle Cutter

The WADE embodies the right principle, worked out through long experience. It is simple, durable and accurate. It trims the needle at an angle resulting in the best tone. The WADE cutters are made of the best steel and are absolutely guaranteed.

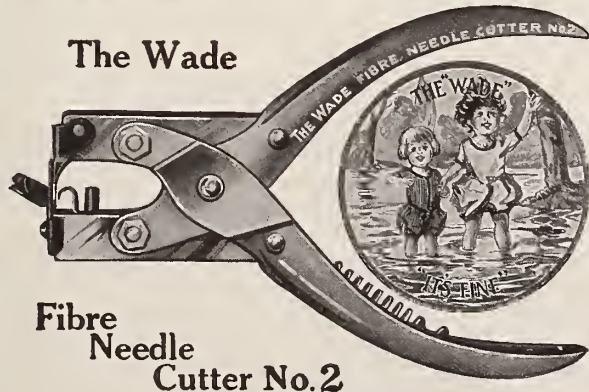

The Wade
Fibre
Needle
Cutter No. 2

The WADE has a self-acting stop, which prevents waste and enables one to get from 12 to 15 perfect playing points. No. 2 has a double action, from one fibre needle, making it especially easy to operate. No. 1 is a very popular cutter which has given excellent service. You save more than double the price of the Wade in the re-pointing of the first 50c. worth of needles.

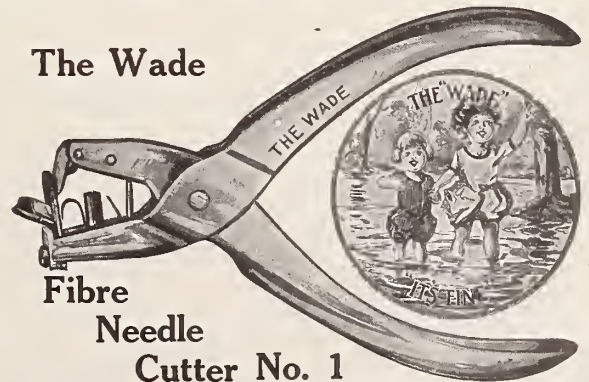

The Wade
Fibre
Needle
Cutter No. 1

RETAIL PRICES—No. 1, \$1.50; No. 2, \$2.00

Order from your regular Distributor—we sell to Jobbers only

WADE & WADE,

3807 Lake Park Ave.
CHICAGO, ILL.



LYON & HEALY extend
heartly thanks to their
many friends for fa-
vors received and trust
that one and all may
enjoy a Happy New
Year! ∴ ∴ ∴ ∴ ∴

FROM OUR CHICAGO HEADQUARTERS—(Continued from page 35).

concerts, for our to-morrow's guests. A. W. Kaney and Miss Claudia Dana, direct from Castle House, have been secured especially for this occasion and will demonstrate the latest dances in the concert room from 1 to 4 in the afternoon. Come!

Retail Manager Otto Schnering has provided a generous stock of machines and records and expects to do a big business. Edwin V. Zeddies managed the dancing exhibition.

Rintelman Needle Introduced.

A. S. Rintelman, head of the Rintelman Piano Co., of Chicago, has formally introduced and is pushing vigorously the new "3-point A. R." needle. The needle is similar in shape to a fiber needle, its sides being concave and affording three points at each of its ends. The material is said to be a mineral product having almost the same degree of hardness as the diamond. Its toughness and elasticity, due to the composite material within it, affords what is said to be perfect transmission. It will withstand the various changes of temperature without expanding or warping, therefore transmission is the same at all times. It is claimed that the needle is practically permanent and that its retail price of \$2.50 is easily secured from those to whom it is demonstrated. Mr. Rintelman says that there is a very generous discount to dealers on this product.

Storage Cabinets in Demand.

An interesting phase of the accessory side of the talking machine business is shown in a recent statement of John F. Mortenson, manager of the Salter Manufacturing Co.

Mr. Mortenson said: "We have received an unusually large number of orders for our storage cabinets, showing that dealers are making early preparations to go after 'after Christmas business,' as January is always a good month for records, and lack of storage room on the part of machine owners generally makes itself manifest at this time. Business generally appears to be very excellent, as we are receiving immense orders and having great difficulty in keeping pace with them. Our Edison cabinets for the smaller Edison machines are proving especially popular and we are getting a big call for them. Cabinets for the Victor No. 9 machines and Columbia 'Favorites' also continue to be good."

Fibre Needle Cutter Sales.

S. O. Wade, head of the Wade & Wade Co., manufacturer of fiber needle cutters, says that the immensity of this year's Christmas trade is shown in the unprecedented business which the Wade cutter is enjoying. "Despite the fact that our dealers heeded our warning and ordered their stock early, we nevertheless are swamped with orders and are working at our best pace to keep up with the demand."

Personals and Visitors.

Mr. and Mrs. Miles, of the Miles Piano Co., Streator, Ill.; J. F. Korn, of the Korn Piano Co., Michigan City, Ind.; Mr. Randolph, of Egerman & Randolph; E. D. Allington, Freeport, Ill.; E. Burkhart, St. Joe, Mich.; E. L. Burr, of Burr Bros., Rockford, Ill.; E. T. Anderson, of Rock Island, Ill., were all recent visitors to the local trade.

L. V. B. Ridgway, Lyon & Healy's Pacific Coast traveler, is spending a few days in Chicago.

A. D. Geissler and wife were recent prominent visitors to the local trade.

L. C. Wiswell, manager of the talking machine department of Lyon & Healy's, announces that he has not yet selected a successor to the position of manager of the retail record department, which was recently vacated by M. M. Blackman.

Roy J. Keith, sales manager of the Talking Machine Co., spent some days in recent trips to Cincinnati and Minneapolis.

Griffith P. Ellis, of the Talking Machine Co., is the daddy of a new baby girl, born November 30. Her real name is Martha Virginia, but because of her loud, clear tones she is commonly known as Victoria, Jr.

Mr. Jackson, of the Talking Machine Shop of Rockford, Ill., and Arch. Olds, of the Clay Pool Music Co., of Crawfordsville, Ind., were recent visitors to the local trade.

Other recent visitors to the local trade included Mr. Milliken, of the Milliken-White Studios, Bay City, Mich.; H. J. Power, of the Taylor Carpet Co., Indianapolis; Albert J. Rice, Lafayette, Ind.; Nick Wirth, Escanaba, Mich.; R. R. Smallfield, Davenport, Ia.; Mr. Weller, of the Red Cross Drug Co., Centerville, Ia.; Edward Druckner, Dyersville, Ill.; Mr. Sutton, of Sutton & Briggs, Clinton, Ind.; Mr. Goodwin, of Goodwin & Co., Monticello, Ind.; W. A. Bryan, of W. A. Bryan & Co., Monticello, Ind.; C. A. Richardson, of Richardson, Ill., and A. G. Kunde, Milwaukee, Wis.

Lyon & Healy's Mammoth Electric Sign.

An electric sign that is one of the largest in the city has been in operation to advertise the goods of Lyon & Healy, manufacturers and dealers in musical instruments. Measuring 68 feet wide and 40 feet deep and carrying approximately 4,000 5-watt and 10-watt tungsten lamps, this sign stands at the corner of Park Row and Michigan avenue, within full view of persons on the latter street for about 1.5 miles. The steel work supporting the

Graphophone Co., tells The Talking Machine World that the last thirty days have broken all business records in history.

"The main difficulty lies in supplying machines," said Mr. Baer. "We are always able to supply records, but we have been completely swamped in the matter of supplying the instruments themselves. The demand of the Mignonette and the Leader models which are fitted with record ejectors, has been particularly heavy.

W. C. Fuhri, district manager of the Columbia Graphophone Co., returned recently from the East and says that while at Bridgeport he saw the factory working at its full capacity, with day and night shifts working every minute of the twenty-four hours.

A few of the new Columbia dealers in this territory are: Charles T. Hess, Elmhurst, Ill.; L. L. Hutton, Gibson City, Ind.; Vincent Quarten, Lake Forest, Ill.; Block & Cool, Peoria, Ill.; F. L. Dixon, Rock Valley, Ia.; Emerson & Hiltbrunner, Cedar Rapids, Ia.; W. J. Massey, Des Moines, Ia.; C. A.



Lyon & Healy's Immense Electric Sign in Chicago.

sign on the buildings at this corner weighs 23 tons.

The border of the sign simulates a lyre within which a Confederate and a Northern soldier are marching at each side, one with a drum and one with a horn. Out of the horn the words, "Marching Fifty Years" are blown by the soldier, this expression being appropriate since the firm has been in business for fifty years. In addition to these flashing words, there is a changeable-letter feature within the sign to allow different departments or the company's business to be exploited.

Pathé Jobber Faring Well.

A. J. O'Neill, of the O'Neill-James Co., announces that his firm, which has secured the local jobbing of the Pathé talking machine, is doing a most satisfactory business and that several substantial dealers have recently taken on the Pathé line. In each case these agents are old established talking machine men who have been much impressed with Pathé possibilities.

The offices of the O'Neill-James Co., in the Hunter building, are to be remodeled and provision made for a demonstration room as well as a display room, in which the entire line of Pathé machines and records will be shown.

Mr. O'Neill's company is distributing considerable advertising matter in the form of catalogs and special folders exploitive of dance records and of favorite operatic selections.

First Dividend Distributed.

The first dividend of 5 per cent. has been declared in the case of the Indiana Music Co., of Terre Haute, Ind., which encountered financial difficulties about the middle of last year. Lane Robertson was head of the concern.

Good Columbia Business.

C. F. Baer, local manager of the Columbia

Electric Sign in Chicago.

Ibblings, Waterloo, Ia.; Sutton & Briggs, Clinton, Ind.; Frederickson Piano Co., Oshkosh, Wis., and Fisher Bros., Appleton, Wis.

It was also announced at the Columbia office that another hit had been scored when the entire Columbia line had been taken on by the retail stores of the Cable Piano Co., in Detroit, Grand Rapids, Battle Creek, Lansing and Jackson, Mich.

Harry Bent Leaves for the Coast.

C. H. ("Harry") Bent leaves for the Pacific Coast Saturday night. Mr. Bent will go first to Coronado Beach, where he will enjoy a complete rest and will later proceed to Los Angeles, where he will make preliminary arrangements for the Cheney talking machine. Mr. Bent is very enthusiastic over the product which is to represent and over the territory in which his work will be. A host of friends in the trade wish Mr. Bent all success in his new undertaking.

Talking Picture Company Incorporated.

The Comer Talking Motion Picture Co. of Chicago has been incorporated for \$10,000 to manufacture, lease, operate and deal in sound-reproducing apparatus, motion picture projectors and films. John J. Comer, Frank Mayer and Guy Van Schoick are the incorporators.

Buys the "Healy Strad."

John McCormack, the celebrated Irish tenor, whose records are so popular in the talking machine trade, has just purchased from Lyon & Healy the famous "Healy Strad" for \$10,500, and Paganini's favorite bow, declared by experts to be the finest in America, for \$500. McCormack, in addition to being one of the world's opera stars, is said to be an accomplished violinist. The "Healy Strad" was made by Stradivarius in 1711, and is considered one of his prize instruments.

MUST BEAR REVENUE STAMP.

War Tax Law Affects Lading Bills and Manifests—Must Be Supplied by Shippers.

On and after Tuesday, December 1, every manifest, bill of lading or evidence of receipt for shipment on a railroad, whether in bulk or in package, must bear an internal revenue stamp, one cent in value, furnished by the shipper.

This is in accordance with the provisions of the War Tax law. The Pennsylvania railroad, in addition to sending instructions to its agents regarding the law's requirements, will endeavor to keep them supplied with stamps, though shippers are requested, where possible, to buy their supplies at the post-offices.

Some idea of the task it will be for the road to supply stamps may be gained from the fact that the road issues 50,000 bills of lading a day.

FLOAT USED IN STREET CARNIVAL.

The advertising department of the Columbia Graphophone Co. received recently from its enterprising dealer in Shelburne Falls, Mass., I. W.

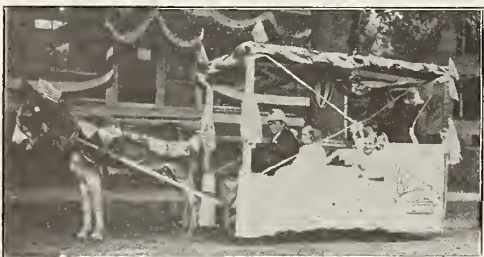

Booker's Columbia Display.

Booker, the photograph shown herewith, depicting a float used by Mr. Booker in a street carnival held in that city.

On the back of the wagon is featured a Columbia "Jewel" machine, and proper band records were played during the demonstration. The Columbia muslin sign covered the whole back of the wagon and both sides of the display. The children shown on the float are Mr. Booker's wide-awake youngsters, who, to all appearances, enjoy immensely the musical qualities of the Columbia "Jewel."

CAUSES FAVORABLE COMMENT.

A Buffalo paper recently contained the following notice: "The return engagement of Reid and Ross, the clever dancers who made such a hit at the Fall Fashion Festival, caused a great deal of favorable comment, and a goodly crowd was on hand to welcome them at the J. N. Adams store. This week Reid and Ross are dancing in the Victrola department, fifth floor, on a specially constructed floor. More than one thousand people saw the dancing yesterday. In addition to dancing, Miss Ross will demonstrate the new dansant frocks that made such an impression at the Fashion Festival. It was news to a great many people that the Victrola could be so effectively used for dancing.

BOOKED SOME GOOD ORDERS.

Philip Ravis, vice-president of the New York Album & Card Co., 25 Lispenard street, New York, manufacturer of record and photographic albums returned this week from an extensive trip through various sections of the country. Mr. Ravis states that general business conditions are steadily growing better, and that dealers are closing an excellent trade with record albums. The most important phase of Mr. Ravis' trip was the large orders he received for the company's photographic albums, which many talking machine dealers are featuring for their holiday trade with gratifying success.

NO LONGER CONNECTED.

The Union Specialty & Plating Co., of Cleveland, O., announces that H. B. McNulty is no longer connected with that company in any capacity.

If you can't be optimistic don't be pessimistic.

Your Opportunity

50 cents stamps brings you a sample of our highly perfected Standard Fibre Needle Cutter.
25 cents stamps brings you a sample of our simple and accurate Standard Automatic Stop.

Samples sent only to bona fide dealers writing on their business letterhead. Place regular orders through your jobber.

STANDARD GRAMAPHONE APPLIANCE CO.

173 LAFAYETTE STREET

NEW YORK

HOLD EDUCATION RECEPTION.

Early Music House, Fort Dodge, Iowa, Hold Third Annual Reception for School Teachers for the Purpose of Creating New Interest in Talking Machines for Schools—Rewarded by Large Attendance—Good Musical Program.

(Special to The Talking Machine World.)

FORT DODGE, IOWA, December 3.—The Early Music House, this city, prominent and successful Victor and Edison dealers, recently held its third annual musical education reception for the school teachers of the city, and the interest aroused by the event was indicated by the large attendance. The reception was held in the evening to permit of the teachers attending without interfering with their regular work, and 135 in all took advantage of the opportunity to hear the latest in musical education helps.

During the reception discussions regarding music in the schools were encouraged, and a discussion on musical expression was particularly interesting, taking the form principally of a debate between the private music teacher and the public school teacher, the general thought being that in time instrumental music would be made a part of the school course, and given a major instead of a minor place.

Through the efforts of the Early Music House the schools in Fort Dodge and vicinity are well supplied with talking machines and records, which is a decided mark of progress in a city where, less than five years ago, there was no supervisor of music.

The formal program laid down by the Early Music House showed much thought and care in its arrangement and should serve as an example for other concerns that are going after the school trade. The program follows:

1. Educational records, Victrola, Edison disc, with explanation by Mr. George L. Bunt. 2. Folk dances, Miss Virginia Lewis and class from Y. W. C. A. 3. Discussion, "Music as an Expression of Mental Activity"; in the home—Mrs. Jeannie Ringland Smeltzer, Fort Dodge Piano School; in education—W. H. Blakely, Principal High School; in gymnastics—C. E. Daubert, Physical Director Y. M. C. A.; in society—Mrs. Elizabeth Carmichael, Supervisor of Music, Fort Dodge Schools. 4. Questions and Answers. 5. Refreshments. Hostesses, Mrs. R. W. Hale, Miss Celia Peters, Miss Mae Connel, Miss Frances Woods, Miss Ida Wiker.

Worst thing about killing time is that most everybody wants to go into some other fellow's game preserve to do it.

To every man who does things there are many who content themselves with telling about what should be done.

Even when they try to rest on their laurels some people are troubled with insomnia.

The man who loses his temper doesn't have to advertise a reward for it.

Much of the success in getting anywhere lies in knowing which road to take.

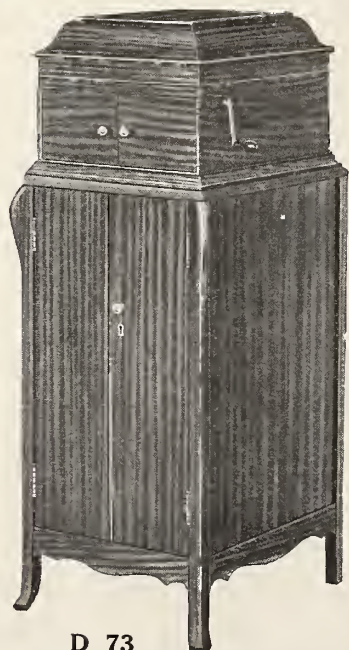

D 73

Mahogany, Golden Oak, F. O. and W. O.
Finished all around.
Sliding Record Shelf.
For IX Victrolas,
Capacity, 192 12-inch Records.

LONG CABINETS

For Christmas

AND AFTER

Why not push Cabinets where machines have been sold?

The Geo. A. Long Cabinet Co.
Hanover, Pa.

Address Clement Beecroft, Sales Manager
309 W. Susquehanna Avenue, Philadelphia



The dealer who carries Columbia product knows that he has one grade of Quality all the time, and also he has the comforting knowledge that he has something to match up pretty well with every pocket that is brought into his store.



(Write for "Music Money," a book "full of meat" for those dealers interested in quick and frequent turnover of capital.)

Columbia Graphophone Company
Woolworth Building, New York

CREATOR OF THE LANSING COVER.

Something of the Popular Bostonian and His Achievement, the Khaki Moving Cover for Talking Machines—Building Up Big Trade.

E. H. Lansing, 611 Washington street, Boston, Mass., is the inventor of the Lansing khaki moving cover for talking machines, which is a covering made of the proper size to fit the various machines, the cover being made of Government khaki and



E. H. Lansing.

interlined with four layers of heavy felt. Since its introduction to the trade, where it instantly filled a long felt want, there have been numerous repeat orders and he is rapidly building a business of large size.

When asked how he happened to create the Lansing moving cover, Mr. Lansing said: "I noticed that several talking machine dealers were paying out a considerable sum of money every month to repair scratches and damages to talking

machines that were delivered in the regular way. If a cover were used this expense would be eliminated, so I proceeded to create the cover. Goods are now delivered in perfect condition, and the cost of the covers was saved in a short time. A number of dealers all over the country are following the same plan, for it is a policy that is in line with today's efficiency."

Mr. Lansing is also a manufacturer of piano scarfs, as well as being a big jobber in piano stools and benches, and in music rolls, so he is thoroughly familiar with delivery problems in the musical instrument trade and knows how to overcome them.

NEW BILL TO PREVENT FRAUD.

National Association of Credit Men Prepares a Bill to Prevent Fraud in Transfer of Accounts Receivable Secretly.

The National Association of Credit Men has prepared a bill designed to prevent fraud in the transfer of accounts receivable, and will endeavor to have it adopted by the legislatures of the various States.

In explaining the purpose of the bill, J. H. Tregoe, secretary-treasurer of the association, said recently that in recent years there had developed the practice of secretly transferring accounts receivable. Accounts receivable are property in the eyes of the law, though not transferable from hand to hand as negotiable credit instruments. While such transfers are obviously in rare instances made only for legitimate reasons, yet the case with which secret transfers may be made actually encourages dishonesty and over-extension of credit.

HIGH PRAISE FROM VIOLINIST.

Mme. Maleta Bonconi, the noted violin virtuoso, while in Sioux City, Ia., recently heard the Edison diamond disc for the first time. She commented very highly on its marvelous reproducing power and the perfect blending of its colors and overtones. Her praise of the Edison violin selections was especially flattering.

AN ORIGINAL WINDOW DISPLAY.

Attractive Thanksgiving Window Arrangement of the Ross P. Curtice Co., Lincoln, Neb., Which Won Considerable Commendation—Originality Produces Results.

Despite the fact that the manufacturing companies supply frequent stock window displays for the use of retail dealers, there is a constantly increasing number of the latter who believe in originating their own displays, in keeping with some local condition or some certain season.

A most interesting example of a seasonable display of the original sort is the Thanksgiving win-



Ross P. Curtice Co.'s Clever Window.

dow in the store of the Ross P. Curtice Co., 1240 O street, Lincoln, Neb., and which is illustrated herewith. The window had a natural board fence for a background, the floor was covered with earth and the display of cornstalks, pumpkins, a turkey and other features generally associated with the Thanksgiving season made the display a most effective one. A Victor XIV acted as a centerpiece for the display.

BUSINESS IS GOOD—THERE'S A REASON

A TRIAL ORDER WILL SHOW YOU

WHY

THE GOODS AND THE SERVICE IS THE ANSWER

The DOME RECORD CASE

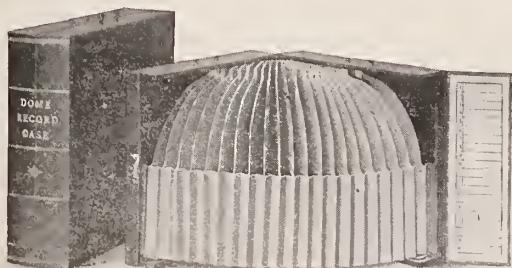

should be in your stock. Holds 20 records. Made in 10" and 12" sizes. Equipped with lock and key. Order samples to-day, with the list of records and that particular style or finish of Victrola you are unable to get elsewhere.

The completeness in filling and promptness in shipping your order will convince you we have both goods and service.

Edison and Victor Distributer

W. D. ANDREWS, Buffalo, N. Y.

THE OUTLOOK FOR THE COMING WINTER SEASON

Discussed in a Most Interesting Way by Ben Switky, the New York Talking Machine Jobber—Optimism and Enthusiasm the Keystones of Success—People Like to Do Business with the Man Who Smiles—Constructive, Helpful, Heart-to-Heart Talk.

Optimism—and plenty of it is the only attitude that we have justified in assuming at the present time under the present conditions. Pessimism is suicidal speaking figuratively, and has no place in the mind of the active business man.

Just as there are men who start out in the morning feeling in perfect health, hear a few friends comment upon the bad weather, and the fact that their complexions do not look just right, read a couple patented medicine advertisements plentiful in symptoms and warnings, and come home feeling sick unto death in the evening; so there are people in business, your competitors or customers for instance, who will keep on buying and selling goods in the usual way, unless some false friends full of pessimism, come to kill all confidence and hope.

People like to do business with the man who can smile—the man whose very confidence in his country, in himself and the line he handles serves to breathe confidence in others and make the future and not the present assume a rosy hue. As a matter of fact, the talking machine men have every reason to belong in the front ranks of the optimists. It is true that our business system has been for a few weeks past a little run down, a trifle nervous. Yes, a bit feverish in the head and chilly in the lower extremities, not that there was anything particularly wrong with the general health, but just slight symptoms of cold feet. Symptoms that for the most part have been treated before they had a chance to develop and have responded to that treatment. It is only natural, however, that as we get very close to the holiday season, the best business season of the whole year, there exists a certain anxiety to know beforehand just how business will compare with that of last winter.

Prophecy is equally the delight of the wise and the foolish. It has been said that "out of the mouths of babes and fools ye shall learn the truth." Therefore, hearken whilst I solemnly forecast a Merry Christmas and a Happy Business for the talking machine trade.

I would recommend that all my readers take the attitude of a friend of mine who, when asked for his opinion of the business outlook, replied: "I don't know whether others will find it good or bad, but I expect to do a bigger business this year than ever before!"

That man has success marching by his side in perfect step.

It might be interesting to analyze this audacious individual whose self-confidence is so great as to be almost convincing: He believes that man is the arbiter of his own destinies and the architect of his own fortune. He turns to good account even the misfortunes of others, believing that "'tis, indeed, an ill wind that blows nobody good."

With such thoughts firmly embedded in his mind, he sets out determined to eclipse all past records. He feels it in his bones, as it were.

Mark the mental attitude: He realizes that it is strictly up to himself. He is not looking for anyone or anything special to help him or to shoulder the blame in the event of failure; furthermore, he has faith that there is no circumstance or condition so unfortunate as to be without benefit to some one. And he means to be that some one.

When you hear people say that business is poor, draw in your belt a notch or two and girdle yourself prepared to double your efforts.

Don't allow the croaker—and he is always with us, in fair weather and in storm—to depress your spirits, the time you spend listening to him can be put to better use in hustling for and making sales.

If you hear talk about bad collections, don't believe it. Collections are always good. It's when you can't collect—that's bad. However, with greater care in the extension of credits and closer attention to collections you may find your business in a healthier state than when things are booming.

The present war has admittedly affected many industries, nevertheless, you will agree with me that the demand for "It's a Long, Long Way to Tipperary" has started the record-buying season off with a hurrah, and as a direct result of the war.

Can any dealer or jobber recall having ever sold so many patriotic selections to so many different nationalities? All of which again illustrates the truth of "'tis, indeed, an ill wind that blows nobody good."

The world just now is in a high state of excitement. Pent-up feelings in this country find vent in appreciation of martial song and music.

The advance sales of talking machines this fall guarantee a still heavier demand for them for the holidays. Christmas business will be as big as you make it. If there is to be any general falling off in holiday buying, we must see to it that the talking machine business shall be the exception. The conditions are right to make it the exception if the proper effort is put forth.

The foregoing statement is logical even if it sounds queer. The answer is simple enough: Suppose that Mr. Jones finds it necessary to curtail his Christmas giving, and instead of spending \$200 he must limit himself to \$100. Now, it is for you to convince him that a talking machine and some records are more attractive and more appropriate than some other things which he had intended purchasing and will in addition give pleasure to the entire family and their friends. Straight-forward salesmanship based upon a thousand first-class arguments and coupled with sincere and unusual efforts is going to make this holiday season a normal season or better for the talking machine dealer.

In other words, if the dealer sets his heart and mind upon making this year's holiday business the greatest ever, nothing can interfere with his success—not even if the whole country were to spend just half the money that it spent last year.

We may not sell so many \$200 machines, but we can, if we are determined, sell as many \$50 and \$75 machines as to make the total gratifying in dollars and cents.

I predict that the sale of the lower-priced instruments will be phenomenal. As for the record business, the demand will be so great that last year's shortage of stock will be repeated three-fold during the next few months.

There is no article more appropriate or more popular as a Christmas gift. With a marvelous range of prices to offer the public, it should be an easy matter to interest them in your wares. Everybody loves music. Almost everyone is dancing these days. The theatrical, operatic and concert seasons are in full swing. Music publishers are putting forth their best efforts. There never was such a plenitude of good material at hand. Great heavens! Can anyone stand and hesitate as to the sort of business we are going to have this winter?

To my mind it seems just a question of helping the public to decide whether they want oak or mahogany. I might grudgingly concede that with some people it may be a question of deciding whether it shall be a \$15 or a \$50 machine, a \$100 or a \$200 machine, but emphatically there is no question of "to be or not to be." So far as we are concerned, that question died with Hamlet.

Enthuse! Arouse yourself to a full realization of the wonderful opportunities at your command! Examine your sample line of machines from a new angle! You are offering the public a thing of joy. Your instruments embody tone, grace, beauty, economy.

Pay no attention to those who complain of bad times. Bad times hardly exist for the talking machine dealer. Instead, mingle with the theater crowds on upper Broadway any evening before 8.15. You would consider yourself, indeed, fortunate to be able to secure a ticket for any good show at the regular box-office rates. Think of the hundreds of crowded pleasure places and take comfort from the reflection that our business belongs in the luxury class, and bear in mind that certain indulgences are necessary to reconcile the people to the sacrifice of certain necessities of life.

ANNOUNCE NEW MACHINE.

Mermod & Co., 505 Fifth Avenue, New York, of which E. L. Cuendet is general manager, announce a new talking machine which will be retailed for \$10. This machine has a wooden cabinet and is tastefully designed. This house has a big business furnishing parts for manufacturing talking machines, including motors, turntables, sound boxes and other accessories, so its experience in the production of talking machines is of a practical nature.

NEW EDISON SALESMEN.

V. E. B. Fuller has recently been added to the sales force of Thomas A. Edison, Inc., to push the sales of the Edison phonographs. Mr. Fuller has had considerable experience in musical lines and is well qualified to present the Edison diamond disc to music discriminating people.

READY REFERENCE OF GENERAL SUPPLIES

DEALERS

Send for our "Trial Proposition" on the Regina Hexaphone—the latest and best paying popular priced coin-operated instrument for use in public places.

THE REGINA CO.

211 Marbridge Bldg., 34th St. and Broadway, New York City
Manufacturers of Regina Music Boxes; Reginaphones;
Coin-operated Mandolin Orchestrons; Vacuum
Cleaners and other specialties.

Mermod & Co.

505 Fifth Avenue New York

Manufacturers of

Talking Machine Supplies

Motors—Sapphire Points

Diamond Points a Specialty

Keep Your Record Stock with

THE
Heise
SYSTEM

Costs about \$2.00 for 250 records for 50 years
Send for 20-page catalog

THE SYRACUSE WIRE WORKS,
SYRACUSE NEW YORK

NEW QUARTERS FOR STEWART CO.

Prominent Victor Jobbers of Indianapolis to Move to Larger Quarters on January 1—Activity with Columbia Co.—Kipp-Link Co. Preparing for Holiday Trade—Latest News.

(Special to The Talking Machine World.)

INDIANAPOLIS, IND., December 8.—After January 1, 1915, the office and salesrooms of the Stewart Talking Machine Co., distributors of the Victor line of talking machines, will be situated at 110 North Pennsylvania street, which is practically in the heart of trade in Indianapolis. The company is now at 221 North Pennsylvania street.

The Stewart Talking Machine Co. in moving is in the position of going back to its first home. When the company was organized several years ago, the business was launched in quarters at 110 North Pennsylvania street. But the room occupied by the company was part of an old-fashioned building and it was not long until the Stewart Co. had to get out so that the building could be torn down.

In the place of this building there is now a modern sixteen-story office building. On the ground floor are commodious rooms and the Stewart Co. is to have ground floor rooms in the building. There will be more demonstrating room available in the new quarters and the company is planning to attractively decorate its new home.

Business with the Stewart Co. is very good, according to W. S. Barringer, manager of the company. The wholesale business of the firm is increasing to such an extent that larger warehouse quarters are needed now and additional salesmen have been employed.

A. W. Roos, manager of the Columbia branch store in Indianapolis, says the month of November proved by a good margin to be the biggest month for total net sales in the history of the firm in Indianapolis. The November business was almost three times as great as that of November of last year. Cash collections are better than the average, says Mr. Roos.

The new Grafonola styles have met with approval by the public and the only complaint Mr. Roos has to make is that it is difficult to keep a sufficient number of machines on hand to supply the demand.

T. Allan Laurie, traveling auditor of the Columbia Graphophone Co., spent ten days at this branch in November. Mr. Roos had the pleasure of taking a dose of his own medicine as he was formerly traveling auditor for the company.

The branch store in Terre Haute, Ind., was visited by Mr. Laurie and Mr. Roos. This store is in charge of L. A. Moeller. He reported a number of sales for the month.

H. M. Wright, floor manager at the Columbia store, says his greatest problem is to work fast enough in ordering and unpacking records for the shelves which continually need replenishing. The last lists issued by the Columbia Co., the regular, as well as the specials, have had an immense popularity. The new dance records and "Tipperary" are the best sellers of the month.

The Kipp-Link Phonograph Co., distributors of the Edison disc machines, is busy preparing for the holiday trade. Rush orders are being received every day, and the entire force of the Kipp-Link Co. is busy.

TO MAKE FLEXIBLE RECORDS.

The Ribbon Record Co., Chicago, Ill., has been incorporated with capital stock of \$100,000 for the purpose of manufacturing and dealing in flexible phonographic records. The incorporators are: John S. Huey, John T. O'Connell and Robert E. Berlet.

A great salesman said: "I sold the goods. I did not merely lay cornerstones and get things into shape; I did not secure a promise of an order the next time; I did not fix the man for a future trade, and then brag about it. Not I. I got the man's name on the bottom of the order sheet. That's what I did."

NEW DEPARTMENT WINS SUCCESS.

Victrola Department of Geo. B. Peck Dry Goods Co., Kansas City, Mo., Proves Excellent Venture—Large Recital Hall and Modern Demonstration Booths Among the Features.

(Special to The Talking Machine World.)

KANSAS CITY, Mo., December 8.—The Victrola department that has been added to George B. Peck Dry Goods Co., since the opening of the new store has exceeded all expectations in the way of



Part of Display Room.

business. "Our business" says John Ditzell, manager "has been twenty per cent. greater than we expected, and our figures were thought to be too high."

The Victrola department is on the seventh floor of the new eleven-story building occupied by the George B. Peck Dry Goods Co. It was constructed



The Recital Hall.

and planned when the building was erected. It is equipped with four demonstration parlors and a concert hall. However, the concert hall has been closed for some time because of the large crowds that used it as a rest room; during the holidays it will be used as a demonstration parlor, after which it will be enlarged so that it will hold a

larger crowd. The department will have practically the entire seventh floor as a display space when the work on the building is completed. The seventh floor is probably the most advantageous location that could be secured for this department, because the offices of the company are also located on the same floor, and all of the best customers of the company transact a large amount of their business here.

John Ditzell, manager of the "Victrola Store," as he prefers to call it, has for the past five years represented the Columbia Co. as a traveler in the southwestern territory.

TO HANDLE COLUMBIA PRODUCTS.

Ashley B. Cohn, vice-president of Hardman, Peck & Co., New York, announced last week that the company had arranged to handle the complete line of the Columbia Graphophone Co. in its talking-machine department. At the present time the company handles the Edison disc phonographs and records, and the addition of the Columbia line will necessitate the construction of additional demonstration booths. It is likely that a portion of the fourth or second floors will be set aside for talking-machine display, which, in addition to the space now occupied, will give Hardman, Peck a large and well-furnished department.

TO HANDLE COLUMBIA LINE.

H. Saletan, 2163 Broadway, New York, has arranged to handle the complete line of the Columbia Co. and feature it aggressively. The excellent location of Mr. Saletan's establishment in the city's west side residential district should assist him considerably in his Columbia campaign for the better-class trade.

THE ENRAPTURED REPORTER.

(From The Aledo (Ill.) Democrat.)

Will Shaw varied the entertainment with some delightful musical numbers both vocal and instrumental, by noted composers and artists who faithfully reproduced themselves in Edison's phonograph—one of the many wonders of our wonderful age, wherewith the "common people" no longer remain "common" because the most costly amusement of the millionaires in palace of art are brought to the humblest homes of those whom nature endowed with appreciative gifts, which money cannot buy, nor the lack of it suppress, and thus the rural town enterprising music store becomes a most prominent factor in the education and elevation of the public taste and interpretation of the classic in music.

Something New for You!



A THREE-POINT NOISELESS TALKING MACHINE NEEDLE

This needle is good for a lifetime and produces real, enjoyable music from any disc record.

RETAIL PRICE \$2.50

Special Terms to Dealers

Send for Catalog

RINTELMAN PIANO CO., MFRS. CHICAGO.

420 Republic Building.

This Needle Makes an Ideal Christmas Gift.

THE TRADE IN PHILADELPHIA AND LOCALITY

(Special to The Talking Machine World.)

PHILADELPHIA, PA., December 8.—The talking-machine business in Philadelphia in November was most satisfactory. At every store it ran considerably ahead of the November of last year, and at several of them they have assured me that it was double what it was last year. The December business has started with a rush and it will only be limited to the number of machines and records that will be supplied the dealers. This is not alone true of the Victor business, but of the Columbia and Edison as well.

Dealers in the Victor do not hope to get, especially in several of the more popular styles, a sufficient number of machines, for already there are orders in hand by the jobbers showing that they will not be able to supply them. The jobbers, however, are using their best judgment and are

putting out these machines to the best advantage. I saw a number of orders, in my rounds of the trade, where retailers have sent checks with them, which the jobbers were compelled to return, as they were not regular purchasers, and they are turning down good money in order to take care of those dealers who have stuck to them and probably will have to wait several months for their money. In the end, however, they expect to profit by this piece of judiciousness on their part.

During the past month there have been no new dealers started here by the Victor, but the Columbia and Edison have placed their machines in a number of satisfactory stores, and especially the former have been most fortunate in this respect.

Series of Edison Concerts.

The Edison people have a corps of promoters here at present who are arranging series of concerts and exhibitions, and their campaign will, no doubt, have a telling effect on the dealers. They are only giving these concerts to organizations which will do them the most good, and each of the individual dealers are also giving concerts in their stores, and there is quite a boom for the Edison here at present.

Blake & Burkhart report that their business has been very good with the Edison, and a visit to the store shows every evidence of this. They have been giving a great many recitals recently, but have had to discontinue them on account of the holiday rush already started. They expect shortly to be open evenings until after Christmas. They have placed a new man on their selling force, Ray England.

Louis Buehn says he is surprised at the terrific demand for talking machines, but that the trade is having a difficulty to get the \$75 and \$100 styles. "Everybody is on the anxious bench about getting stuff," he says, "but records are coming in very fair." He says that the large talking-machine dealers in Philadelphia are quite well fixed with goods, which is in strong contrast with last year, when they went through the fall and the holiday season at a practically from hand-to-mouth rate.

Mr. Buehn has found an increased demand for the Edison dictating machine, and has recently placed these labor savers with the Lutheran Publication Society, the Keystone Type Foundry, the Presbyterian Ministers' Association and the Re-

formed Publication Co., as well as a number of smaller firms.

Manager Comerer, head of the piano and talking-machine department at Wanamakers, says that their business is going big. They have twenty-eight hearing rooms at present and they are filled every day. The new style Victor, sold for \$150, has come in, and he believes that it is going to be a winner, as the public takes well to the idea of having the case finished all around, with the new arrangement for the albums. They give recitals every day at Wanamaker's, and have placed a large force in the talking machine department for the holiday trade, mostly through their own resources in the store, for they have a system whereby they train men in the stock department to be salesmen and utilize them when necessary.

The Pennsylvania Talking Machine Co. reports that its business in November has been all that it could possibly expect, having surpassed last year with a very substantial gain. Manager Eckhart says: "December is only going to be limited by the amount of goods I am going to get from the factory. I have never, in the years that I have been in this business, seen it come as it is coming at present. Machines have been coming in and going out so rapidly that we have practically encroached upon the city of Philadelphia, in the way we have blocked the streets back of our store all the way from Heppes to Cunninghams, nearly the extent of piano row, in which we are sandwiched."

Mr. Eckhart says that the Columbia dictaphone has also been a most active part of his business in November, and that they have a number of important demonstrations now on which they expect to close the first of the year. A number of their November sales were to the Dupont Powder Works and the Hercules Powder Works, of Wilmington; the Bush Sons Transportation Co., J. G. McIlvain Lumber Co., Surface Lumber Co., Fenton Label Co., and the Hill School at Pottstown.

New Columbia Dealers.

During November they placed the Columbia machine in the following establishments: B. Miller, 604 South Second street, in which they put a full stock on a big contract; A. Wolson, of Chester; William R. Irvin, Mount Carmel, Pa.; F. A. Jenkins, Honesdale, Pa.; Ramsey, Donnelly Co., of

**PENN
PHONOGRAPH CO.
PHILADELPHIA**

**Largest
Stock of
Victor Records
and Victrolas
in
Pennsylvania**

*Orders Filled
Immediately
Upon Receipt*

**Give us a trial and be
convinced**

**PENN PHONOGRAPH CO.
17 South 9th Street
Opposite Post Office, Philadelphia**

The Keystone of The Buehn Service is Completeness

When you order various models of machines, ten to one, and even more odds, the type that you need the most is the style that is missing. A big sale is postponed—perhaps lost—and you suffer in profits. Next time test the Real Service of

**Louis Buehn
Philadelphia, Pa.**

Handling Talking Machines exclusively you secure a specialized co-operation of the highest character.

**Edison
Cylinder**

**Victor
Disc**

Salem, N. J.; E. E. Tuttle, Halstead, Pa.; W. C. Kantner, Reading, who has been restored as a Columbia dealer, and a number of others.

Mr. Eckhart, who is supervising the Columbia Grafonola business of Baltimore, is very well pleased with recent results there. The Pennsylvania Co. have recently taken over the Delaware Graphophone Co., of Wilmington, and Mr. Eckhart is personally interested in the business, while John W. Goldie remains the manager. They have increased their selling force by the addition of several new men. Among the recent visitors were James P. Bradt, of the Columbia Co., New York.

Gimbel Brothers report that they have done a tremendous business in November, and fully doubled their business of last year, and Manager Stewart says that he expects the department to have a very fine holiday trade, as they are well supplied with instruments to take care of it. The department has arranged a number of attractive Christmas suggestions which will help the purchaser materially. They have added to their selling force H. M. Hillebrand, a son of the manager of the Aeolian and Pianola departments at Heppes.

ENLARGES SALES STAFF.

Increase of Pathé Frères Phonograph Co. Business Necessitates Much Larger Force.

The Pathé Frères Phonograph Co., 29 West Thirty-eighth street, New York, manufacturer of the Pathephone and Pathé discs, has added to its already large staff a number of experienced men for its sales, clerical and shipping departments. This additional force was found necessary because of the remarkably rapid increase in its business which the company has experienced since making its first announcement to the trade.

An officer of the company stated this week that jobber and dealer arrangements for the Pathé Frères were being closed daily and that valuable territory from coast to coast is being requested by representative members of the industry. The Pathé dance records, which were recorded under the supervision of Maurice and Florence Walton, dancers of international renown, are meeting with a ready sale throughout the country.

THE VANOPHONE CO. INCORPORATED.

A certificate of incorporation was filed last week with the Secretary of State, Albany, N. Y., by the Vanophone Co., which will manufacture phonographs, accessories and devices. The capital for this new concern is \$250,000, and the incorporators are M. W. Aron, W. L. and H. F. Wray, Brooklyn, N. Y.

WIN SUCCESS WITH EDISON DISC.

The McKee Surgical Instrument Co., dealers in doctors', nurses' and invalids' supplies, has for some time past handled the Edison diamond disc phonograph very successfully in its Washington store and has only recently secured jobbers' rights for the same line for its store in Baltimore.

TO MAKE PHONOGRAPHS.

The Operaphone Manufacturing Corporation filed a certificate of incorporation on Saturday with the Secretary of State, Albany, N. Y., to engage in the manufacture of phonographs and records. The capital is given as \$100,000, and the incorporators are E. F. Gerner, M. Naughton and John Fletcher, of Douglaston.

Edison once said he "could excuse an ignorant man groping in the dark," but he "had no time to waste on a man that knew he was in the dark and didn't find his way out." Know your business thoroughly—try and learn the methods by which some men conduct business profitably—apply them so far as you can to your business—learn why some men fail and try to avoid their mistakes.

A poor excuse is better than none—if it passes muster with the boss.

VICTOR CO. SUES R. H. MACY & CO.

Prominent New York Department Store Asked to Account for Advertising Victor Machines and Records at Cut Prices to Purchasers.

The Victor Talking Machine Co. filed a suit in the United States District Court at New York on November 19 against R. H. Macy & Co., New York, the prominent department store. This action is based on the advertising used by R. H. Macy & Co. in the local newspapers offering Victor machines and records at cut prices, in alleged violation of the provisions of the agreements, by which the goods are licensed under the Victor Co.'s patents. The Victor Co. asks for an injunction restraining R. H. Macy & Co. from selling the goods or offering them for sale, at less than the prices named in the license agreements and for an accounting and damages.

WANT TO TAX MAIL ORDER HOUSES.

National Merchants and Manufacturers' Association with Headquarters in Nashville Back of a Bill with That End in View.

The National Merchants' and Manufacturers' Association, with headquarters in Nashville, Tenn., is at present carrying on a strong campaign in support of a bill introduced into the House of Representatives last May by Congressman Hinebaugh, of Illinois, and which is designed to levy a tax of 1 per cent. on all business done by mail order houses, conducting an interstate business.

The bill provides that mail order houses shall file statements with the Secretary of the Treasury at the end of each year showing the cash value of all merchandise sold during the year. The bill also provides that the Secretary of the Treasury shall apportion all such taxes collected among the several States in the ratio of the actual amount of goods sold in each State.

The association, through its secretary, states that it has been informed that the collection of

such a tax for the benefit of the State would be constitutional.

The bill it appears, failed to pass the last session of Congress, but the association is now working to secure its passage during the coming session.

HEATH APPOINTED MANAGER

Of the Baltimore Store of the Columbia Graphophone Co.

Albert J. Heath, formerly a member of the firm of Gorham & Heath, Brooklyn, N. Y., successful Columbia dealers and well versed in all details of Columbia merchandising, has been appointed manager of the Baltimore store of the Columbia Graphophone Co. Mr. Heath succeeds George A. Baker, who was appointed to the Baltimore managership a few months since, but who returns to New York to resume his duties as assistant manager of the wholesale Columbia headquarters, at 89 Chambers street, New York, which position he occupied before leaving for Baltimore.

R. F. Bolton, district manager of New York and up-State wholesale territory, whose activities were recently increased considerably, will be obliged to devote so much time to his new fields that a thoroughly experienced man was needed in New York as assistant manager, and Mr. Baker's previous connection with the New York headquarters was invaluable for these important requirements.

DEATH OF MRS. WALTER P. PHILLIPS.

Walter P. Phillips, who has long been associated with the Columbia Co., at its headquarters in Bridgeport, Conn., is receiving the sympathy of his many friends on the death of his wife, which occurred on November 28 in that city, in her sixty-eighth year. Mrs. Phillips was born in Attleboro, Mass., and was married in 1866. She is survived by her husband, a son, Albert C. Phillips, two sisters and two brothers.

ORDER TO-DAY

THE

Lansing Khaki Moving Cover

FOR TALKING MACHINES HEAVILY PADDED AND QUILTED

This Government-Khaki Heavily-Padded Moving Cover is endorsed by all Manufacturers of Talking Machines and is recommended to every Dealer as an indispensable help in moving the Talking Machines from the Warehouse to the Home, and for all Outside Demonstrations.

It more than saves its cost in paper and string, besides the time of "Bundling Up" every time you take a machine off the floor. It pre-

vents marring and scratching, and the cabinets are delivered free from finger marks, landing the instruments without a blemish, thereby making a Contented Customer, which means added business in both records and supplies.

The new CARRYING STRAP, with its two loop handles, shown in the cut above, is simple, safe and convenient and absolutely necessary in safely handling these heavy machines.

COVERS MADE IN TWO GRADES:

"A," Felt Inter-lining, \$7.50, Without Strap

"B," Cotton Inter-lining, \$5.00, Without Strap

All large cabinet covers

The No. 3 Strap is \$1.00 extra

(Only one strap needed on each wagon or automobile)

E. H. LANSING, 611 Washington Street, Boston, Mass.





They are telling us that the three Columbia "Tipperary" records—song, march and dance—are to-day the biggest things in the industry.



(Write for "Music Money," a book "full of meat" for those dealers interested in quick and frequent turnover of capital.)

Columbia Graphophone Company
Woolworth Building, New York

GAIN OVER LAST YEAR'S BUSINESS IN ST. LOUIS.

With the Majority of Dealers the Low Priced Machines Have the Call—Improvement in General Business Helps Trade—Announcement of New Aeolian-Vocalion Arouses Interest—Good Reports from the Country Districts—Interesting News of the Month.

(Special to The Talking Machine World.)

St. Louis, Mo., December 7.—Local talking machine dealers—except those specializing in low priced machines—are looking forward to an excellent Christmas business. They say that they have many prospects for holiday sales on file and that new inquiries are coming daily and that these sales indicate, almost wholly, the sale of high priced machines, those from \$75 up, with records extra.

It also is a fact that practically all St. Louis houses that make talking machines a department in the selling will show gain this year over last if the Christmas business is fair. December 1 saw a neat gain recorded in sales totals for the year in most houses and a gain in practically all. There may be a few exceptions, but there are no notable stores in the list, if confidential information is to be relied on.

While the general depression of business, from which St. Louis is now beginning to emerge, has shattered plans made a year ago and totals January 1 will be far below the figure set as the mark, but the business, in spite of the practical sweeping away of all of the "wage earner" purchases, will be sufficient to maintain the record of "greater business every year" for the talking machine trade. There are two elements at work in the matter of fewer small machine sales, the new one being the fact that many wage earners have been out of employment and those who have had regular work have been apprehensive of further slowing down and have held tightly on to what money they got. The other is the fast spreading belief that only a higher priced talking machine is worth while. The class of customers who formerly saved \$25 and bought a machine for that sum as a cash sale is becoming less very rapidly, and the amount that formerly made the entire purchase now is being used for a first payment in the belief that they are getting better value. Except for special purpose and for use in addition to a large machine, the small priced talking machine is disappearing from the market, and in many local stores the number of machines sold this year will not be more than half that of two years ago, while the total business will be much greater.

There perhaps will be one change this year that will be welcome in the shipping rooms. This will be that business conditions will curtail the demand to somewhere near the ability of the factories to meet all orders, and there will not be the effort to ship something to every dealer who has an order on file. So far this year the distribution has been

ample and practically complete orders are leaving the local jobbing houses without delay. Heretofore it has been the worry of the merchandise superintendent and the shipping clerk to divide twenty machines among fifty-three orders, or some other impossible fraction. Record stocks are said to be in excellent shape, and any dealer who wants a late rush order will be safe in entrusting it to St. Louis jobbers, as they all avow with one accord that they are going to be able to meet all demands and will have their shipping rooms keyed up to make a perfect record, and in this way boost the yearly totals to the best figure possible.

The spirit displayed by all hands here is that when business is under a handicap that is the time to put on extra steam.

Much Interest in New Aeolian-Vocalion.

The trade here has been greatly interested in the news printed in The Music Trade Review late in November that the Aeolian-Vocalion had been displayed to the trade in New York City. All sorts of rumors had been current here as to the intention of this company for future merchandising of talking machines, and the limited statement given out from the New York Aeolian Hall appeared to answer the general question; that the Aeolian Co. was making its own talking machines and that it would be different in some respects from any machine on the market.

Harry Levy, of the talking machine department at Aeolian Hall here, declined to discuss the new machine, except to say that he expected to have some of the machines on display early in the New Year. "In the meantime," he said, "I am very busy keeping pace with the demands of our rapidly expanding retail department."

Aeolian Hall has been conducting an active advertising campaign on behalf of its talking machine department, but other dealers, who, naturally under the circumstances, have been watching the advertising closely, professed to see in it more talking machine and less of the boosting of a particular instrument.

Some Popular Columbia Styles.

At the Columbia warerooms Retail Manager Duffy says the demand has been centering largely on the Favorite and Mignonette styles with record ejector attachments. The sales of these machines, he says, is practically limited to the supply placed at the disposal of the retail department. The extraordinary demand for dance records continues with the Columbia Co., and the use of these records, coupled with the specialized advertising, has served to open a wide field for machine sales which, it is anticipated, will expand as the wage earners return to their usual occupations.

C. R. Salmon, of the wholesale department, reports excellent business in all parts of that trade territory except in the cotton country. "Our late orders are running heavy," he said, "and we may

yet experience trouble in supplying all holiday wants, although we still are shipping promptly. We now are caring for the last of the regular holiday orders and we will then be in shape to anticipate the late special or rush orders.

"I have sent our J. J. Bennett out on a flying trip through southern Illinois and other near-by territory. He is out to put a little 'pep' into the dealers who fail to grasp the holiday possibilities, and the reports he sends in are very encouraging."

Manager I. B. Reid, of the Columbia warerooms, made a short visit to Chicago the first of the month.

Manager Robinson, of the Thiebes Piano Co. talking machine department, was detained at home the first of the month by illness.

Mark Silverstone, president of the Silverstone Music Co., Edison jobber, was heels over head in work at the month end, planning an energetic advertising campaign for the holidays. Mr. Silverstone recently has made his advertising on a more general basis, boosting the Edison machine more than the Silverstone service, with frequent references to the number of dealers handling the machines.

The Silverstone Co. reports business in excellent condition and attributes the mounting totals of this store and the other retail salesrooms of the Edison machines to the fact that they have been seeking, since the disc machine was put on the market, to urge the sale largely on higher priced machines, and that this class of trade has suffered less this winter than the lower priced trade. A heavy shipment of machines received the first of the month taxed the capacity of the Silverstone ample warerooms, but an extra shipping force put on duty soon cleared the decks by getting them out to waiting dealers.

Better Conditions in Country Districts.

E. C. Rauth, of the Koerber-Brenner Music Co., has spent considerable time on the road recently and reports excellent conditions in the country districts. Conditions there have improved more rapidly in the city, because of the reawakened demand for grains, which was checked for a time, and the extraordinary sales of horses. Money is getting plentiful and country dealers are ordering with much more freedom than for early fall stocks. Those who anticipated that early fall orders would suffice for the holidays are repeating orders and only because of ample preparations and the refusal of Koerber-Brenner to become pessimistic as to the future of the talking machine business are they able to meet the demands made upon them. When this company became exclusive jobbers of the Victor line in this territory Messrs. Koerber and Rauth gave out assurance that they would at all times be prepared to meet the demands made upon them, and they had this pledge in mind when they made preparations for this season beyond what the advance orders appeared to justify.

More people might try to pose as angels if everybody didn't start right in and begin to look at them with suspicion.

Greatness is never thrust upon a man who leads an aimless life.

**NEW JERSEY
PRICE TALKING MACHINE CO.
VICTOR DISTRIBUTOR
(Exclusively)
We can supply ALL your wants on time.
NEWARK**

FROM OUR EUROPEAN HEADQUARTERS

2 GRESHAM BUILDING, BASINGHALL STREET E. C., LONDON, W. LIONEL STURDY, MANAGER.

Review of Trade Conditions Shows That England Is Doing Well Considering the Circumstances—Some Active Advertising Being Conducted by Gramophone Men—Reynolds, War Supplement—Death of A. H. Littleton—O. Heinemann to Visit America—Columbia Co.'s Generosity Much Appreciated.

(Special to The Talking Machine World.)

LONDON, E. C., December 5.—As the war proceeds, and the days lengthen into weeks, the weeks into months, the months into —, commercial men have good cause to glorify the British fleet, which, by its vigilance alone, under the most trying conditions, insures for them an uninterrupted maintenance of business relations with oversea buyers. Dependent upon a continuity of general commerce is the very existence of the gramophone trade to-day. With supreme command of the seas, England's machinery of trade is comparatively unaffected, outside of course the severance of trade exchanges with enemy countries. Recent official returns provide an excellent index of internal conditions, in that unemployment generally compares to-day very favorably with even time last year. In no one field of industry can it be said that conditions are bad. If we take the gramophone trade as a pregnant example—it is one of the first to reflect the worst of such a position as we find ourselves in—what do we find? I will endeavor to answer in conformity with actual opinion as generally expressed in the course of interviews with prominent gramophone men. Let it be said at once that in some quarters trade is more or less at a standstill, partly on account of lack of supplies. British talking machine interests, however, present a condition of activity quite out of all proportion to the prospects when war was declared. In the main, record and machine sales are satisfactory, and more than one company has conclusively proved that even under present circumstances it is possible to maintain a substantial turnover. While employment is good, the spending power of the masses is somewhat restricted owing to the prevalence of salary reductions and consequent economy. Money being difficult to extract from the pockets of the public in the ordinary way, the larger record and musical instrument houses feel it necessary to invest in publicity with the object of breaking down this reluctance to part company with the "needful." The response has been good. Yet with it all there is a feeling of uncertainty abroad as to possible developments in the war area, and until some decisive conclusion may be drawn pertaining to the ultimate likely outcome of this gigantic struggle between the forces of right and might the gramophone industry cannot expect to recover stability. To sum up, the general view here is that things might be worse, but all influences of an ad-

verse nature considered, bulk trade is vastly better than anticipated. While every section of trade and the community at large continue to be animated with the patriotic and common-sense spirit of making the best of circumstances, maintenance of gramophone trade, even though on a reduced scale, is assured.

Some Active Advertising Campaigns.

A survey of the gramophone trade situation on this side would be quite incomplete without a reference to the splendid press advertising campaigns embarked upon by some of the leading record houses. All circumstances considered, it must be admitted that publicity expenditure, with the object of stimulating sales of an article of luxury rather than necessity, more closely approximates to a speculation than an investment. This aspect of the situation has only to be realized by dealers to insure a more active co-operation than at present obtains. I do not hesitate to say that the success of this advertising rests almost entirely with the retail distributors upon whom mainly rest the opportunity of transforming mere inquiries into profitable orders. To the question, Do dealers systematically follow up inquiries? the answer could not be an unqualified affirmative one. It comes to this, that sooner or later manufacturers will realize the necessity of themselves clinching the deal direct, and afterward credit their best dealers in each locality from whence the original inquiry emanated.

In passing, I must congratulate the Gramophone Co., Ltd., Zonophone and Columbia concerns upon their whole-hearted efforts to maintain talking machine sales "as usual," by consistent publicity, thus setting an encouraging example to the faint-hearted members of our industry.

Coincident with the commencement of an extensive press advertising campaign, the British Zonophone Co., Ltd., announce a new list of patriotic records, bearing the pick of recent war compositions. These records have been recorded by eminent Zonophone artists, and may be accepted as fitting examples of the very high standard of quality which characterize in general Zonophone recording. The December supplementary list is replete with first-class selling titles, and should be in the hands of all oversea dealers who have a market for London's best.

Reynolds' War Supplement.

"The man of many parts," W. H. Reynolds advises us that he is now in a position to supply complete machines of British manufacture. These are built throughout in conformity with the best traditions of British workmanship, and thorough reliability. For the complete instrument, or any part thereof, competitive prices rule, and will be found to compare favorably with Continental rates. A war supplement giving full details of new lines

is now ready. Traders abroad are asked to remember that "any part of any talking machine ever made" may still be obtained from this live firm.

The Latest Beka Records.

In the latest Beka supplement there is to be noted a further aggregation of good selling titles of a patriotic and Xmas flavor, although in the latter regard a separate program has been issued, containing many well-known hymns, carols, descriptive and other suitable titles.

A New "Meister" Record List.

A further list of "Meister" twelve-inch records is now ready. It comprises a number of good operatic and ballad items which make a special appeal to high-class traders, whose clientele is mainly of the musically-educated type. Very special care has been devoted in the recording of these twelve-inch Beka records. Full lists and terms can only be obtained from O. Ruhl, Ltd., 77 City road, London, E. C.

Trade Very Quiet in Russia.

A significant indication of the quiet state of the interior of Russia is afforded by a communication from the "His Master's Voice" Russian manager, A. T. Lack, in which he asks his wife to leave the safe shores of England and join him in Petrograd. Mr. Lack, by the way, was in London when the war broke out, yet despite the closing of the usual Continental routes, he determined, if possible, to reach Petrograd by way of Scandinavia. It was a risky undertaking, but he got through notwithstanding the existence in the North Sea and the Baltic of German mines sown broadcast, men o' war, submarines, etc.

A Remarkable Test of "Silver Sheath" Needles.

Various patent needles have at times been condemned on account of the extra wear to which they subject records, and in this connection the rebutting claims made on behalf of the "Silver Sheath" needle are of interest. Daws Clarke, of Manchester, bears witness to the results of a remarkable test. A record carrying two verses was selected. The first verse has now been played 442 times; the second verse only occasionally for purposes of comparison, and the result is no appreciable difference in tone. Excellent testimony surely to the non-wearing and smooth playing quality of this unique needle.

Death of Alfred Henry Littleton.

Widespread regret will be felt at the news of the death of Alfred Henry Littleton, chairman of Novello & Co., the well-known music publishers. He was born in London in 1845. He was a member of the Royal College of Music, the committee of the Royal Choral Society, and was master of the Musicians' Company in 1910-11. A personal friend of Verdi, Gounod (whom the firm of Novello paid

(Continued on page 46.)

"RENO, THE MAN OF MANY PARTS"

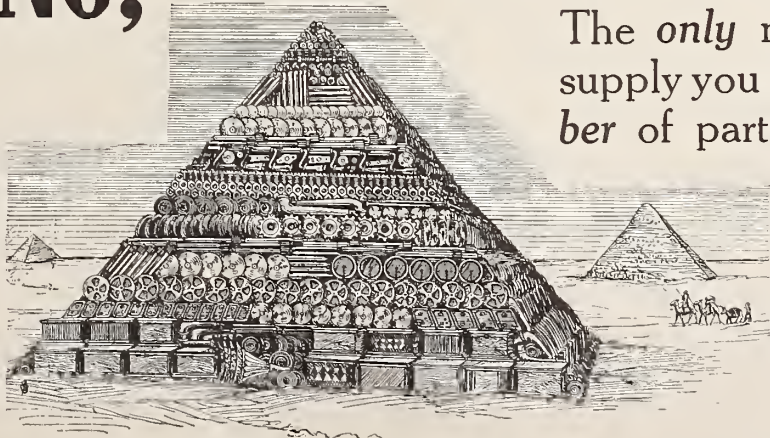

The *only* man in the world who can supply you with *one* part—or *any* number of parts for *any* Talking machine ever made from Adam to Edison-Roosevelt.

64 Page Catalogue Yours for Asking

W. H. REYNOLDS, Ltd.
"KNOTASLEPE"
London, England

FROM OUR LONDON HEADQUARTERS—(Continued from page 45).

£4,000 for the copyright of "Redemption"), Liszt, and many more of the prominent European musicians. Mr. Littleton occupied for a long time a unique position in the music-social world.

According to a recent public announcement, the Albion Record Co., Ltd., this city, has decided to go into voluntary liquidation, and to that end a meeting of creditors was held last month. The liquidator is S. C. Brown, 22-24 Tabernacle street.

New Companies Incorporated.

Diaphone, Ltd., described as musical instrument manufacturers. Capital, £33,000. Registered office, 203 Regent street, London, W.

H. P. Hodges, Ltd., music dealers. Capital, £5,000. Office, 117 Above Bar, Southampton.

Records for the Fighting Men.

The recent call for supplies of records for the use of our sailors, who naturally want something to relieve the monotony of their dangerous vigil in the North Sea, has met everywhere with a very hearty response. A Belfast paper gives prominence to an appeal for more records, and underneath the editorial we notice a timely reminder from Thos. Edens Osborne, which may induce those so minded to purchase records for dispatch to the fleet, of which almost every ship is now equipped with one or more gramophones.

Miss Margaret Woodrow Wilson's Records.

Of exceptional interest is the Columbia list this month, for it announces records by no less a celebrity than the daughter of the President of the United States, Miss Margaret Woodrow Wilson, which are already well known in the States.

Miss Wilson is a singer of unusual attainment, as has long been known to her own circle of acquaintances, and her voice is "naturally" an organ of singularly beautiful tone. It has been developed under the direction of the world's leading teachers and this training has resulted in not only a singer, but an artist of notable interpretative attainment.

New European General Manager.

The Columbia Graphophone Co., London, has sent out a formal announcement to the trade to the effect that Louis Sterling has been appointed Eu-

ropean general manager of the company, succeeding J. A. B. Cromelin to that position. Mr. Cromelin's conspicuous abilities, displayed while in charge in Europe, recently won him promotion to the post of general manager of the Columbia Co., with headquarters in New York. Mr. Sterling is well and favorably known in the trade here, and is well qualified to assume the duties of his new office.

O. Heinemann on Visit to America.

O. Heinemann, a director of Carl Lindstrom (Berlin), is now on a visit to America. He pays generous tribute to the courteous treatment of our officials, but thinks he will be more useful on your side of the pond than in London, where his movements and commercial plans were naturally somewhat restricted.

Llewellyn Davies Makes a Change.

The trade will learn with interest that Llewellyn Davies has resigned his position at the Wholesale

Musical Supply Co., Ltd., this city, to take up an important service with the Perforated Music Co., Ltd., of City road, London. Mr. Davies' long experience in the gramophone and music trades is a sure foundation upon which to rest our belief that he will reap the highest success in his new sphere.

Columbia Co.'s Generous Donation.

Under date of November 23, the Columbia Graphophone Co. advise me of a further donation on account of royalties from the sale of Regal records to the Prince of Wales' National Relief Fund. This latest contribution of £250 brings the Columbia total to the handsome sum of £1,000, which speaks volumes for the truly regal support from trade and public alike of the company's active assistance in behalf of those who qualify for participation under this magnificent scheme. The latter, by the way, has now to its credit over £4,000,000 voluntarily subscribed by the public from all parts of the British Empire.

AN IMPORTANT NEW RECORD PROPOSITION.

W. D. Enville Simons, Late Sales Manager of the Thos. A. Edison Co., in Control of Big Undertaking, the Details of Which He Explains in an Interesting Way.

(Special to The Talking Machine World.)

LONDON, ENG., December 1.—A matter of world-wide interest is the recent formation of a new concern which has for its objects the marketing of an entirely new type of double disc and an attractive range of exclusively designed instruments. Located at the now historical address, 81 City road, London, in the very heart of "phonoland," by the way, the Diamond Disc Record Co., Ltd., is particularly fortunate in having as its general manager W. D. Enville Simons, late sales manager of the Thomas A. Edison Co., who is well known and popular throughout the whole trade.

The diamond disc is of the phono-cut type with a thread between that of the Edison and Pathé records, double-sided, played with a jewel point, ten and one-half inches in diameter, with playing time up to three and one-half minutes, and is priced at eighteen pence retail. It weight is said to be

close upon double that of the average needle record.

Since public opinion varies somewhat with regard to volume, the company will issue records in two strengths—"concert" records of extra loud volume and records of ordinary volume, at the same price. Interviewed on the subject of policy and trading prospects, Mr. Simons, speaking enthusiastically of the progressive demand for a competitive price record of the phono type, said: "The trend of public opinion is undoubtedly in favor of sapphire-played records, and I consider the diamond products make a timely appearance in conformity with trade expansion in this direction. The field has not been developed to anywhere near its enormous sales possibilities for an intermediate priced record, and I am convinced that our future prospects will materialize into a sound commercial undertaking of influence and standing in the gramophone world. Already quite a substantial number of orders are in



"His Master's Voice"

Copyright

This intensely human picture stands for all that is best in music

—it is the "His Master's Voice" trade-mark, and it brings to you, no matter where you are, the very best music of every kind, sung and played by the world's greatest artists — the greatest singers, pianists, violinists, orchestras and bands—all enshrined in the unequalled "His Master's Voice" records.

'His Master's Voice'

—the trade-mark that is recognized throughout the world as the

HALL-MARK OF QUALITY

Branches

AUSTRIA: Oesterr. Grammophon - Gesellschaft, m.b.H., Graben 29, Trattnerhof I, Vienna I, Austria.

BELGIUM: Cie. Française du Gramophone, 51, Avenue de la Porte de Hal, Brussels.

DENMARK: Skandinavisk Grammophon-Aktiesselskab, Frihavnen, Copenhagen.

FRANCE: Cie. Française du Gramophone, 115 Boulevard Richard Lenoir, Place de la République, Paris.

GERMANY: Deutsche Grammophon - Aktiengesellschaft, 35, Ritterstrasse, Berlin.

HUNGARY: The Gramophone Co., Ltd., Kosuth Lajos-Utca 8, Budapest.

SPAIN: Cia. Francesca del Gramophone, 56, Balmes, Barcelona.

SWEDEN: Skandinaviska Grammophon - Aktiefbolaget, Drottning Gatan No. 47, Stockholm.

RUSSIA: The Gramophone Co., Ltd., 45, Nevsky Prospect, Petrograd (Petersburg); 9, Golovinsky Prospect, Tiflis; Nowy-Swiat 30, Warsaw.

INDIA: The Gramophone Co., Ltd., 139, Balhaghatta Road, Calcutta; 7, Bell Lane, Fort, Bombay.

Agencies

AUSTRALIA: S. Hoffnung & Co., Ltd., Sole Concessionaires of The Gramophone Company, Limited, 163, Pitt Street, Sydney.

NEW ZEALAND: E. J. Hyams & Co., Post Box 45, Wellington.

SOUTH AFRICA: Darter & Sons, Post Box 174, Capetown; Mackay Bros., Post Box 251, Johannesburg; Mackay Bros. & McMahon, Post Box 419, Durban; Ivan H. Haarbarger, Post Box 105, Bloemfontein; Franz Moeller, Post Box 108, East London; B. J. Ewins & Co., Post Box 86, Queenstown; Handel House, Kimberley; Laurence & Cope, Post Box 132, Bulawayo; The Argus Co., Salisbury.

EAST AFRICA: Bayley & Co., Lourenzo Marques.

HOLLAND: American Import Co., 22a, Amsterd Veerkade, The Hague.

ITALY: A. Bossi & Co., Via Orefici 2, Milan.

EGYPT (Also for the Soudan, Greece and the Ottoman Empire): K. Fr. Vogel, Post Box 414, Alexandria.

Great Britain:

The Gramophone Company, Ltd.

HAYES - MIDDLESEX - ENGLAND

BEKA DOUBLE-SIDED RECORDS

BRITISH MADE THROUGHOUT.

SOME RECENT EXAMPLES.

**A BIG PATRIOTIC
AND XMAS LIST
OF NEW TITLES
—NOW READY—**

All hot sellers!!

- | | |
|---|--|
| <p>924 "Hail King Christmas," Part I; Empire Military Band.</p> <p>925 "Hail King Christmas," Part II; Empire Military Band.</p> <p>925 "Hail King Christmas," Part IV; Empire Military Band.</p> <p>925 "Le Pere la Victoire" (Louis Ganne), Empire Military Band.</p> <p>927 "Mon Amie" (J. H. Larway), Beka Bijou Orchestra.</p> <p>927 "Pctals Intermezzo" (Raymond), Beka Bijou Orchestra.</p> <p>928 "The Blue Dragons" (Kennedy Russell), Jamieson Dodds.</p> <p>928 "Sons of the Motherland" (Lionel Monckton), Victor, Conway.</p> | <p>932 "When the Angelus is Ringing" (Bert Grant), Stanley Kirkby.</p> <p>932 "You've Got Me and I've Got You" (Scott and Godfrey), Stanley Kirkby.</p> <p>934 "Billy Whitlock—Special Constable" (W. Whitlock), Whitlock and Party.</p> <p>934 "The Bloke Wot's Left Behind"; a Cockney's Lament (Percy Tarling), Charles Penrose.</p> <p>935 "Boxing Day at Sea" (W. Whitlock), Whitlock and Party.</p> <p>935 "Christmas Eve at the Front" (W. Whitlock), Whitlock and Party.</p> <p>936 "The Ancient K'nut" (W. Whitlock), Whitlock and Party.</p> <p>936 "Chuckles" (W. Whitlock), W. Whitlock.</p> |
|---|--|

Complete catalogue and trading terms on application.

O. RUHL, Ltd., 77 CITY ROAD, LONDON, E. C., ENGLAND.

FROM OUR LONDON HEADQUARTERS—(Continued from page 46).

hand for early delivery in this country, and plans for the development of a big campaign overseas will shortly come into operation. We are out," continued Mr. Simons, "with a very tempting proposition based upon products mechanically and scientifically perfect in every respect. Our moderate prices are proportionate to the enormous sales which are bound to accrue, and on these grounds the diamond agency will be one of the most profitable ever placed before the trade." In justification of his confidence in the future of the phono disc, Mr. Simons cited the one time apathy of even America's grand old man, and whose efforts and ingenuity are to a great extent now devoted to this type of record.

In regard to trading policy, I learned the diamond products will be marketed through factors or jobbers only. Pathé trading being direct through dealers, Mr. Simons believes that factors will therefore greatly appreciate the exclusive opportunity thus presented to handle a competitive line of phono discs, price considered, free of competition. Notwithstanding this exclusively wholesale policy, the Diamond Co. will take care to arouse dealers to the wonderful trading prospects of its goods. Large expenditures upon trade, newspaper and other publicity will commence forthwith, and this advertising is to be so closely associated with the requirements of factors and dealers that they will directly benefit by special advertisements placed in its local mediums.

Although price maintenance conditions will be rigidly enforced, Diamond traders are not required to sign obnoxious agreements, it being only necessary to conform with certain simple sales conditions. Recognizing the enormous number of gramophones in use to-day, Mr. Simons estimates on 4,000,000—all available to be fitted with the new Diamond sound box, the latter is so constructed as to be ready for use on any make of instrument without troublesome adjustments, which one must admit is a most important thing.

COLONIAL and FOREIGN BUYERS

of gramophones and records may obtain valuable information from English firms who are desirous of opening up trading relations with oversea markets upon application, stating requirements, etc., to our European representative,

W. LIONEL STURDY

2 Gresham Buildings,
Basinghall St., London, E. C.

Diamond discs carry no labels, the necessary particulars being engraved on the record itself. All Diamond products will be marketed under a distinctive color—Union blue, and a unique registered trade-mark, which makes them instantly recognizable whenever displayed.

On the question of artists, I was told that practically all the well-known and popular vocal and instrumentalists, orchestral and band combinations have made some fine records, and in addition, many new stars will make their gramophone debut under the aegis of the Diamond. Typical titles form a special feature of the Diamond program, and a point of unusual interest is that in this regard factors and dealers will be encouraged to co-operate in catering for local requirements. In other words, the company invite suggestions for the production of titles particular to individual localities. "Tell your readers," said Mr. Simons, "that many new ideas will operate with a view to building up a really first-class catalog, and thus making Diamond discs the popular line of every year." December will witness the publication of a big initial musical program in good time for the Xmas trade. Here are some examples of the artistic value of Diamonds:

First Life Guards, Scots Guards, Irish Guards, King's Colonials, Midland Silver Prize Band, Metropolitan Band, Anglo-American Orchestra (from the White City), Royal Court Orchestra, the Harrison Trio (violin, flute and harp), Bernard Hall (violin), Elsie James (the original Gaiety Girl), Billy Williams, Mark Sheridan, Will Evans, Whit Cunliffe, Geo. Lashwood, Margaret Hayes, Mme. Clara Lewis, Alfred Heather, Humphrey Bishop, Westminster Choir, the Royal Operatic Singers, etc.

Having heard records by some of the foregoing artists I am able to say they are in every way splendid examples of the recording art. Good volume, musically pure in tone, absence of undue scratch, comprise features of the Diamond record which will undoubtedly carry it to great heights in public estimation. To the trade the Diamond agency should prove of exceptional value and I can but urge my readers to immediately investigate such a good business proposition. Fuller information may be obtained by writing direct to the Diamond Disc Record Co., Ltd., 81 City road, London, E. C.

SHORT-PAID POSTAGE HURTS TRADE

Notwithstanding the efforts of the different departments of the Government and those of many commercial organizations and trade papers, some American firms desiring to establish business relations with Chilean dealers and merchants have not yet learned that it is necessary to pay foreign postage on all mail sent. According to Consul D. J. Myers, Iquique, the regulations of the International Postal Union require the postal authorities of the United States to accept and forward all short-paid letters to foreign countries, but no rules of the foreign office compel the addressee to accept such mail and pay the penalty of double the deficiency. In mails arriving from the United States recently fifteen letters from American firms were received at the Iquique consulate. Six of these carried two-cent stamps, instead of five-cent ones, as required. The letters with full-paid postage were delivered in twenty-four hours, but notices of the arrival of the short-paid letters were not received until almost a week after these letters had reached Chile.

POINTS TO CONSIDER.

Because crating and packing may be considered non-productive work is a poor excuse for neglecting it. And besides, a little neglect here may cause a big expense in the way of claims for damaged goods, particularly those sent to foreign countries.

Just when a man's conviction that he is the whole thing becomes perfect he may find himself suddenly retired to obscurity.

STROH VIOLS

VIOLIN, VIOLA, ETC.

The mellow and matured tone of these instruments, which are constructed largely of aluminum, yet possess none of the characteristics of the gramophone or wind instrument, is only one of its many points which are fully set out in an illustrated booklet which will be mailed free on request to the sole makers.

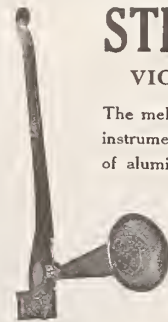

String Fiddle

GEO. EVANS & CO. 94 Albany St. London, Eng.

OR in U. S. A. to their sole representatives

OLIVER DITSON CO.

150 Tremont Street BOSTON
NEW YORK and PHILADELPHIA



Violin

The Patent Silver-Sheath Needles

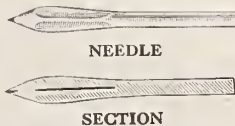

They come between steel and fibre needles and wear your records less than any metallic needle whatever. Each S/Sheath will play 400 to 500 records, with occasional resharpening.

Medium loud tone—clearest results possible—scratch almost done away with.

Prices } 1 S/Sheath Needle...\$0.25
} 6 Needles with sharpener 1.65
Post Free: } Aluminum Sharpener, separately50

Ask for particulars of the FLEX loud speaking diaphragm, etc.

**DAWS CLARKE, 14 Lorne Grove
WANTED AGENTS. Good Trade Discount.**

COLUMBIA GRAPHOPHONE CO.'S HOME IN BOSTON.

Rearrangement of Store Consequent on Widening of Avery Street Gives Boston House Much Additional Window Display as Well as a Much More Attractive Establishment for Display of Their Varied Lines of Talking Machines and Records.

(Special to The Talking Machine World.)

BOSTON, MASS., December 10.—The Columbia Graphophone Co.'s establishment in this city, located at 174 Tremont street, now occupies one of the most central locations in Boston, as the various improvements which the near-by streets have been undergoing are entirely finished and a new street, known as Avery street, runs next to the store. The Columbia headquarters are located on a corner di-

practicable and an aid to the convenience of the store's patrons it is immediately put into daily use.

Arthur C. Erisman is manager of the Boston store of the Columbia Graphophone Co., and it has been under his able management that the Boston territory has become such a fertile and profitable one for Columbia products. Mr. Erisman is fully conversant with the unlimited sales possibilities afforded by Columbia machines and records, and he



Street View of Columbia Phonograph Co.'s Boston Store.

rectly opposite the famous Boston Common, and the traffic which the store attracts is well set forth by the accompanying photograph, taken a fortnight since.

Although the location of this store has undoubtedly been an important factor in the establishment's signal success, the main reason for the steadily increasing popularity of Columbia products in this territory lies in the efficiency of the store's sales

has left no stone unturned to make the store at 174 Tremont street a Mecca for Boston's music lovers.

A feature of the local Columbia store's business the past year has been the remarkable dance record trade it has closed. The Columbia establishment has co-operated with various prominent newspapers and other local mediums of publicity in acquainting the public with the true beauty of the modern dances, and the scope of the Columbia dance record



A Section of the Artistic Columbia Warerooms in Boston.

staff, the progressive advertising policy it pursues, and the quality of Columbia machines and records. Every perfected idea in retail merchandising which applies to the "talker" industry is carefully tried and tested out by the store, and if it is found to be

library enabled the store to achieve truly wonderful results. In its general business, the local headquarters of the Columbia Co. are breaking all records, showing a substantial gain, month for month over 1913, its previous banner year.

SANG WITH OWN EDISON RECORD.

Natural Quality of Edison Diamond Disc Demonstrated in Interesting Manner in Des Moines by Operatic Artist.

(Special to The Talking Machine World.)

DES MOINES, IA., December 5.—Anna Case, an Edison artist, while in this city recent, in concert recital, pleased her audiences immensely, and they gave her a most enthusiastic reception. While here she visited the store of Harger & Blish, Edison jobbers, where she desired to hear her own voice on some recent Edison disc records. During the playing on the disc of her "Louise" she started to sing the aria while the Edison phonograph was playing it. The effect was beautiful. The pitch, quality and tone were perfect; not a shade was lost. She would alternately start and stop picking up the aria here and there, and it showed how accurately the Edison disc had reproduced her voice. When she approached the high passages the effect was like operating the grand swell on a great organ. It was a fine demonstration of the perfection of the recording of her voice on the Edison diamond disc.

VICTOR HOLIDAY PUBLICITY.

The Victor Co. sent out to its trade this week its usual set of special holiday advertising matter. Chief among this publicity is a handsome lithographed Christmas folder with a typical Christmas cover, and supporting the company extensive national magazine advertising with the query, "Will there be a Victrola in your home this Christmas?" Inside of this folder there is a beautiful picture of a home scene in colors that is typical of the Christmas spirit. Turning back this picture is displayed the entire line of Victrolas lithographed in colors. The last page contains a convincing Victrola argument, with space for the dealer's imprint.

Another special folder included in this publicity is devoted exclusively to the Victrola IV, and shows in its center pages a splendid cut of this machine, together with its most important constructional features. On the back of this folder is presented a short list of records representative of the wealth of diversified music that may be found in the Victor record catalog.

HANDSOME NEW QUARTERS.

Hook Bros. Piano Co., Madison, Wis., has just occupied its new building on Capital Square, and fitted up one of the most attractive talking machine departments in the State for the exclusive exploitation of the Edison diamond disc.

EDISON DISC PHONOGRAPH CATALOG.

The Edison people have recently issued a handsome new catalog of "Edison Diamond Disc Phonographs," in the introduction of which we find a statement giving a clear and concise explanation of the peculiarities of the new Edison disc and of the machine designed by Mr. Edison to play it.

Its many feet are what enable a gas bill to run up so rapidly.

"Here is Your Answer;" in WEBSTER'S NEW INTERNATIONAL —THE MERRIAM WEBSTER

It answers with final authority all kinds of questions in Language, History, Biography, Fiction, Trades, Arts, and Sciences.

400,000 Words and Phrases Defined.

6000 Illustrations.

2700 Pages.

Write for specimen pages, etc., FREE.

G. & C. Merriam Co., Springfield, Mass.

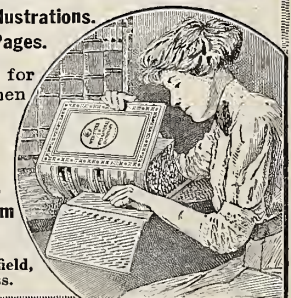

O. K. HOUCK CO.'S SPECIAL WINDOW.

The Popular Music Trade Man of Memphis Arranges Special Window in Honor of the Tri-City Ceremonial of the Nobles of the Mystic Shrine—The Victrola Crosses the Hot Sands.

(Special to The Talking Machine World.)

MEMPHIS, TENN., December 7.—There are no Nobles of the Mystic Shrine in the State of Tennessee and apparently very few in any section of the United States who do not know personally, or have heard of, O. K. Houck, who is one of the most



O. K. Houck Co.'s Mystic Shrine Window.

active of Shriners. It was most fitting, therefore, that the O. K. Houck Piano Co., of which Mr. Houck is the head, should prepare a special window display in honor of the tri-State ceremonial of the Nobles of the Mystic Shrine held recently.

A perusal of the accompanying illustration indicates better than words the elaborate character of the display. There was a pyramid at the back, hanging against which was a portrait of Imperial Potentate Dr. Frederick R. Smith, and in the row underneath portraits of Potentates of the Wahavi

Temple, Jackson, Miss.; Sahara Temple, Pine Bluff, Ark., and Al Chymia Temple, Memphis. The bottom of the window was covered with sand and small cactus and "crossing the hot sands" was a camel with two humps wearing an Al Chymia fez, harnessed to a small Victrola, with Victor records for wheels. Following the Victrola was a lion and a wild cat, illustrating the old saying that "Music hath charms to soothe the savage breast." There was also displayed in the window a copy of the official program of the entertainment held on Tuesday, November 24, together with two signs referring to the crossing of the hot sands to the music of the Victrola. The whole window was lighted by a large emblem of Al Chymia Temple, outlined with electric lights, the emblem, together with the menagerie, having been borrowed from the Shrine.

Those who attended the convention of the National Association of Talking Machine Jobbers at Atlantic City last summer will recognize hanging along the sides of the pyramid the "Keys to Memphis," which were

so liberally distributed by Mr. Houck on that occasion. Throughout the period of the ceremonial the Houck display was one of the centers of interest for all Shriners, as well as thousands of others outside the fold, which, of course, pleased the genial O. K.

God bless the man with a scheme, an idea. It may be visionary, but in any case it certainly must be better than resting all the time.—Leslie M. Shaw.

IMPORTANT NEW CONNECTIONS.

Pathé Frères Phonograph Co. Arranges for Representation in Many Sections of the Country—Big Shipments from Europe.

During the past month the Pathé Frères Phonograph Co., 29 West Thirty-eighth street, New York, has closed a number of important deals for representation in various sections of the country, including both distributor and dealer agencies. The company has inaugurated an aggressive publicity campaign through different mediums, and its many machine and record catalogs which are high grade in every detail, are calculated to give the prospective purchaser an adequate understanding of the qualities of the Pathephone and Pathé discs.

Referring to the general business situation at the present time, an officer of the company said: "We are progressing very nicely in all departments of our business, and as a matter of fact, we have been working nights recently to keep pace with the demands of our trade. We have increased our sales and office staffs considerably the past few weeks, and one of our traveling representatives is now making a trip through Illinois and the surrounding territory with gratifying success.

"Our shipments from abroad have been causing us no concern whatsoever, but, on the contrary, our shipments have been as large as if there was no war or commercial disturbance on the other side of the Atlantic. The extent of our shipments may be gathered from the fact that the inspectors at the New York Customs House advised us this week that our latest shipment was the largest single shipment of any merchandise that had been received in this country since the war started.

"We are more than pleased with the reception accorded our machines and records throughout the country, and the dealers that we established a month or so ago are enthusiastic in approving the distinctive features of our product. The complete opera scores and unusually fine dance records are all giving perfect satisfaction to our dealers and their patrons."

The Flexible Four Pointed Steel Needles

PATENTED IN U. S.—FOREIGN PATENTS PENDING

Four Pointed Flexible Needle

FLEXIBLE

PATENTED
FOUR TUNES ON ONE NEEDLE

Flexible Needles are guaranteed to play the Longest Records Perfectly.

Flexible Needles are guaranteed to save the record from wear.

Flexible Needles are guaranteed to eliminate the scratch.

Flexible Needles make old records sound like new.

Flexible Needles are better because they do more.

Flexible Needles are made from the best steel obtainable.

Flexible Needles are the best for any record because they bring out all that is in the record.

Write to the Nearer

In Attractive Packages of 200 Points.
Increase Your Profit.
Send for Samples and Prices today.
Two Sources of Supply.

JOHN M. DEAN, Inc.
PUTNAM, CONN.

SAMUEL LEVIN
HIGHLAND PARK, ILL.

FLEXIBLE

FLEXIBLE

FLEXIBLE

FLEXIBLE

A CHRISTMAS SERMON FROM SANTA CLAUS.

In Which the Merry Old Elf Discusses Among Other Things the Talking Machine as a Factor in Human Happiness and Enjoyment During the Holiday Period — Interesting Comments on Useless Christmas Presents and the Most Appropriate Ones.

I was dozing by the open fire in the library. The wind was rising among the maples outside the window, and I could even hear the sharp crackle of the thin ice along the shores of the Rancocas as the flooding tide split it asunder.

Ever and anon a snowflake came down the chimney only to sputter into steam as it encountered the blazing logs. My pipe had gone out but I was really so comfortable that even that did not matter. I gazed sleepily at my desk where pad and pencil, uncovered typewriter, and a goodly store of manuscript paper called me to work.

"Go hang! all of you!" I cried, and closed my eyes.

A low chuckle answered me from the fireplace, and I sat up with a start. Standing with his back to the flames, gazing at me from two very merry blue eyes, and bathed in a soft and mellow glow,



The Christmas Spirit.

stood Santa Claus. I had seen too many caricatures of His Majesty of the toys and reindeer not to know him at once. Strange to say, it did not seem unusual that he should be there. In fact, I remembered wishing only a short time before that I could procure some ideas from him regarding my prospective Christmas story already overdue. "If anybody is well posted concerning Yuletide gifts," I had ruminated, "Santa is the chap. Wish I could interview him."

"Well," chortled my fat little visitor, puffing away at his stubby pipe, "I got your *mentigram* and I'm here to be interviewed."

Aroused to my duties as host, I placed an easy chair near my own, brought forth a serving table with samovar, cigars and tobacco urn, and bade my guest be seated. He complied with a flourish, and I thought, or was it imagination? that his red paunch shook a little as he moved, just as it did on "the night before Christmas," long ago. He helped himself to my oolong, filled his short-stemmed clay from my store of Bull Durham, and signified his willingness to be interrogated.

"Mr. Claus," I began, do you know anything about talking machines?"

"Inasmuch as I handle thousands of 'em every year, I should say, 'Yes.'" Then reaching again for the samovar, he continued, "This refreshment of yours is very warming after a long ride in the snow; I'll take another if you don't mind," and he poured out another cup.

"Do you consider the talking machine an appropriate Christmas gift?" I asked him.

"Emphatically so," he replied, and crossing one fur-booted leg over the other, and shaking his finger at me by way of emphasis, he launched forth as follows: "If the people upon this earth stopped a moment to consider just how great an instrument of music the talking machine has grown to be, there would necessarily be a few million less worthless parcels go into my sleigh. However, they are waking up, these people, and the time is not far distant, I am sure, when the money now spent for articles of great price but of absolutely no value will go for records by Caruso and Melba. I've handled presents for hundreds of years, as you doubtless know. There is nothing from a penny doll to a brownstone mansion in the way of a Yuletide gift since the world began that is not written down upon my books. That being the case, I am unquestionably the greatest authority extant upon that particular subject."

He paused a moment to relight his pipe and settle himself more comfortably in his chair, then, quite at ease, he continued: "You gentlemen of the talking machine fraternity are in a position to do a wonderful amount of good this Christmas time. I say *this* Christmas time because, it seems to me, that never before were you so amply qualified to fulfill this mission of uplifting your fellowmen."

"I don't quite get you, friend Claus," I remarked doubtfully. "We are merchants, not clergymen."

"Exactly," quoth Santa between puffs, amused at my skepticism, "but nevertheless you have the greater opportunities to accomplish the end I have in view. Listen, and I'll make myself clear. The reverend gentleman can only talk to his flock of the folly of their ways and explain to them as forcefully as is consistent with the restrictions of his particular denomination what will ultimately befall them if they depart from the straight and narrow path. You go to church; therefore, you know the method employed there?"

"Oh, yes, of course—that is, I have been to church," I answered, endeavoring to be truthful.

"Very well, now I will show you how you can do infinitely more good with your bottled songbirds and canned musical organizations than the theologian with his sermons, no matter how carefully prepared they may be, because you are in a position to prescribe an antidote where he is not.

"Young folks won't stay off the streets at night just because they are told they should. The fact that it is supposed to be wrong, makes it far more alluring. This same idea, of course, applies to the cheap theater, the sensational movie parlor, and the dance hall.

"Now then, this is where you come in," and he grinned at me most encouragingly. "By the introduction of your talking machine with the right kind of records, and your moving picture machine for the home with its wealth of valuable and intensely interesting films, you can make home more alluring than the dance hall and the theater, and thereby solve the problem.

"There is no better way of rapidly advancing



NYOIL

For polishing varnished woodwork it is extremely satisfactory. No oil is so clean.

Ask your watch repairer whose oil he uses on your watch.

civilization than by making the home more attractive than the street, thus eliminating the desire to wander abroad in the nocturnal hours, and, also destroying the germ of immorality with which the night air is saturated. The fellow would be a poor fool who would prefer a dollar a night cabaret singer to Geraldine Farrar, or a squawky dance hall orchestra to Sousa or Liberati."

"I get your idea, Mr. Claus, and I beg to assure you that I deem it well worthy of deep consideration," I exclaimed enthusiastically. "I shall see that it is exploited with the elaboration it deserves."

"I am glad to know that," he replied seriously, "because it proves that my visit here to-night will not be in vain. What is most needed at this time, and what you can help me to bring about," he added even more seriously, "is the expenditure of money along the lines that will do the most good toward the advancement of civilization. I have watched the evolution of this terrestrial sphere with a great deal of interest throughout the centuries, and I am sometimes very much discouraged. Especially is this true when I see a fond mother presenting her offspring with a \$500 jewel-encrusted cigarette case instead of elevating his mind, eyes and ears with good music and interesting views, all of which could be done for less money than was expended by the doting parent for this bauble.

You spoke not long since, Mr. Claus," I reminded him, "of the fact that we are able to do more good toward the uplifting of our fellowmen than even the clergy can accomplish. Why not collaborate with these gentlemen?"

"By all means do so," cried my guest, as he adjusted his furs for departure, "for by making the church attractive as well as religious through the medium of the phonograph and the motion picture, you will accomplish great things."

"Please do not hurry," I entreated, as he drew on his mittens, and pulled his peaked cap, with its silken tassel, down over his ears. "Won't you have another cup before you go?"

He filled his cup once more and lifted it right jauntily, "I give you this toast," he said:

TO A MERRY CHRISTMAS

Out of the northland do I come,
A Saint of the sleigh and toys,
Making happy the Christmas time
Each year for girls and boys,
Right merry chap they say I am,
Rich in good deeds too,
Yearning to please the ones I serve.
Can't beat that, can you?
Here's to your health before I go;
Right well have you served me here.
In after years I'll think of you,
So free with your cup and cheer.
To-night we part, but who can say;
Maybe we'll meet again.
A last farewell, good luck to you;
So-long, knight of the pen.

I seemed to hear the distant tinkle of sleighbells, the faint thud of hoofs upon the roof, and an echo of the driver's commands to his reindeer steeds, then all was still.

"You've been dreaming, dear, and it's bedtime." A loving hand caressed my brow, and I awoke.

HOWARD TAYLOR MIDDLETON.

Every Record User a Positive Customer

The "DUSTOFF" is a positive necessity to every user of Records.

Cleans All Makes of Records

Ensures clear, distinct tonal reproduction free from blurs, scrapings and harsh sounds.

"DUSTOFF"

(Regular 15c. Model)
RECORD CLEANER

Their use adds life to records—"DUSTOFF"s get into the minute sound grooves and thoroughly remove accumulated dust and dirt.

GET THE GENUINE "DUSTOFF"

Of all good jobbers, or write to us direct.

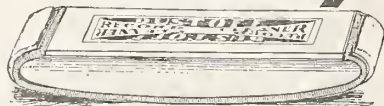

MINUTE SHINE COMPANY
(Originators and Pioneers)
283 Canal St., Providence, R. I.

15c.
Model
40% Discount



Margarete Matzenauer, leading contralto of the Metropolitan Opera House, has just made her first Columbia records.



(Write for "Music Money," a book "full of meat" for those dealers interested in quick and frequent turnover of capital.)

Columbia Graphophone Company
Woolworth Building, New York

FRESH PROOFS OF ENTERPRISE IN SAN FRANCISCO.

Rearrangement of Talking Machine Stores, Attractive Displays, New Quarters All Tell the Story of Prosperity in the Talking Machine Field—Depression Has Affected These Establishments Less Than Any Other Line of Business—What Dealers Say.

(Special to The Talking Machine World.)

SAN FRANCISCO, CAL., December 5.—General improvements in the talking machine quarters of this city in the past year are one of the best bits of evidence that that branch of business suffered less from the general depression, which has been felt more or less all over the country, than most other lines of trade. There is hardly a talking machine department here, but what has undergone changes recently, and two new places have started in the last few months. The Hauschildt Music Co. is the latest concern to seek new quarters, which will give it much better facilities for all branches of its business, and particularly the talking machine department. The remodeling of the ground floor of Clark, Wise & Co. has just been completed. The new Edison Shop on Geary street is a notable addition of this fall; the department on the ground floor of Eilers' Music House isn't much older, and only last month the opening of headquarters here for the Sonora Phonograph Co. was reported. It hasn't been very long since Sherman, Clay & Co. had their entire third floor, which is devoted to talking machines, done over, and not many months have elapsed since the Pacific Phonograph Co. moved its jobbing business from Mission street to new quarters on Geary. In each instance the moves and changes were in the nature of improvements, and at the present time San Francisco can well be proud of her talking machine headquarters. Judging from reports from various interests, business has warranted the forward strides. While other merchants have been complaining very few complaints have emanated from talking machine sources, and holiday trade is starting in quite briskly. The distributors are being rushed, and retailers are already holding a good many outfits for Christmas delivery.

Hauschildt Music Co. in New Quarters.

The new location of the Hauschildt Music Co. is at 105 Kearny street, in the same block with Sherman, Clay & Co. and the Wiley B. Allen Co. The store was formerly occupied by the old firm of Benj. Curtaz & Sons. The company moved in last week, but the remodeling of the premises is still in progress. The talking machine department is located on the ground floor, where five demonstration rooms are being installed. These will be absolutely sound-proof, and they are so arranged that four others can easily be added at a future date, if business warrants. There is also ample room for general display purposes. The building is a four-story and basement structure, 30x130 feet, which provides nearly 20,000 square feet of floor space. Offices have been installed at the rear of the ground floor, and the small goods department will occupy part of the floor in conjunction with talking machines. The second and third floors are being fitted up for piano and player-piano salesrooms. The fourth floor will be

utilized for shop purposes, and the basement for storage. When the work in progress is completed, the store will present an attractive appearance, and will be conveniently arranged for both customers and employees. Henry Hauschildt, head of the company, who spends most of his time at the Oakland store, says they have been enjoying an excellent business in talking machines at both locations. He handles Victor, Columbia and Edison goods, and he reports the demand increasing rapidly for Edison disc products.

Demonstration Room for Sonora Co.

A demonstration room was installed at the Sonora Phonograph Co.'s quarters on the Arcade floor of the Phelan building the past month, and other improvements have been made in the furnishings and equipment. Manager F. B. Travers reports business starting off encouragingly, and he expects to work up a nice business on the Pacific Coast for Sonora products.

Clark, Wise & Co. Store Remodeled.

Since remodeling their store, Clark, Wise & Co. have very attractive talking machine parlors on the ground floor. The remodeling called for the installation of three more demonstration rooms and a reception room, which gives the place a home-like appearance and takes away the decided store atmosphere, making it comfortable for patrons to come in, rest awhile, and listen to the new records without feeling obligated to purchase. Mr. Wise thinks this feature will lead to an increased sale of records, however. This room is situated under the extension of the mezzanine floor, and is furnished with writing desk, settees and other conveniences.

Excellent Outlook in the North.

Andrew G. McCarthy, who looks after Sherman, Clay & Co.'s Victor business, returned a short time ago after a visit to the company's interests in the Northwest. He reported business slightly improved in the Northern cities, and is enthusiastic over the firm's new store in Spokane, Wash., which will be ready for occupancy either just before the holidays or just after. He says business is booming in the wholesale department here. Four carloads of Victor goods arrived a few days ago, and three of them were reshipped to their branch stores and other dealers, whom they supply, on the following day. Retail business is gaining impetus also as the holidays approach.

M. Dorian Arranging for Columbia Exhibit.

M. Dorian, treasurer of the Columbia Graphophone Co., has been in San Francisco since November 1. He has charge of arrangements for the company's exhibit at the exposition, and has devoted most of his attention while here to preparations for the display. From all indications, his firm plans to make an elaborate showing. He is optimistic regarding prospects for the remainder of this year and next. He called on the trade

in the Northwest en route here, and was well pleased with the reports submitted by Columbia connections in Portland, Seattle and Spokane. He says the San Francisco agency has made a splendid record this year, more business having been done in the first ten months than during the entire year of 1914. He expects to leave for home early in December.

New Manager for Emporium Department.

A change has taken place in the management of the Emporium music department, Harry Marcus succeeding A. A. Schell. Mr. Marcus comes from Pittsburgh, where he was manager for Jacob Doll & Sons, and prior to taking that position was connected with the trade in New York. This is his first experience on the Pacific Coast, and he arrives with the intention of bringing the talking machine and piano business of the Emporium up to the highest possible standard. Columbia goods are handled by this firm exclusively. Mr. Schell has not announced definite future plans.

IN CHARGE OF NEW LANDAY STORE.

Benj. Landay has been appointed manager of the new Victor store of Landay Bros., Victor distributors at 23 West Forty-second street, New York, which was formally opened on Monday of this week. Mr. Landay, although comparatively young in years, thoroughly understands the principles of high-grade Victor merchandising, having been connected with his brothers in the conduct of other Victor stores in the Landay Bros.' chain.

Don't loaf around waiting for good luck. Buckle down and compel good luck to come a-running.

Many a man who fails to score in this world says the tally sheet is wrong.

WE BUY
Talking Machine
NOTES
LEASES
AND
CONTRACTS

From Responsible
Dealers & Manufacturers
EMPIRE SECURITY CO.
Harris Trust Bldg. CHICAGO

LATEST PATENTS RELATING TO TALKING MACHINES AND RECORDS

(Special to The Talking Machine World.)

WASHINGTON, D. C., December 10.—STYLUS GUIDING ATTACHMENT FOR SOUND RECORDS.—Harrison W. Rogers, Wheeling, W. Va., assignor of one-half to Charles W. Ebeling, same place. Patent No. 1,112,838.

The present invention relates to improvements in stylus guiding and starting attachments for sound records, one object of the invention being the provision of an attachment adapted to be connected to and carried by a sound record, and provided with means whereby the stylus will be properly guided to a selected point of the sound groove, thus producing a device which is especially adapted for use in connection with a record carrier operated from a projector mechanism, as particularly set forth in a copending application filed February 7, 1913, Serial No. 746,890, the present attachment rendering it an easy matter for the operator to position the stylus for entering a selected point of the sound groove when the record carrier is operated at the proper time through the projector mechanism.

A further object of the present invention is the provision of an attachment carrying a stylus receiving and guiding portion which is so constructed as to be readily adjusted relatively to the sound groove of the record, so that the stylus will be started at a selected point of the groove, and without the necessity of causing the record to be rotated a plurality of revolutions before the sound wave forming portion of the record is in operable engagement with the stylus.

A still further object of the present invention is the provision of a stylus guiding attachment, which will reinforce the sound record at the starting point of the phonic groove, in that a metal, or other hard substance is placed to receive the initial presenta-

Albert L. Roethe, Milwaukee, Wis. Patent No. 1,113,911.

This invention consists in what is herein particularly set forth with reference to the accompanying drawings, its objects being to eliminate hissing noise in sound reproductions from graphophone and gramophone records and to improve the tone

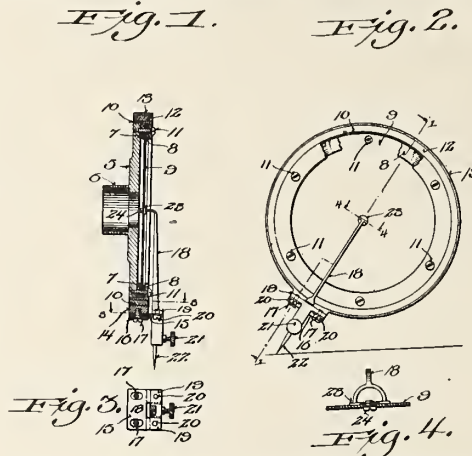

of such reproductions by means of improved sound boxes to which this invention relates.

Fig. 1 of the drawings represents a sectional view of one of the improved sound boxes and is indicated by line 1—1 in Fig. 2; Fig. 2 of said drawings represents a side elevation of the sound-box partly broken away; Fig. 3, a plan view of a detail of said sound box partly in horizontal section as indicated by line 3—3 in Fig. 1, and Fig. 4, a partly sectional view of another detail of the aforesaid sound box on the plane indicated by line 4—4 in Fig. 2.

DIAPHRAGM FOR SOUND REPRODUCERS.—Frederick W. Thomas, New York City, N. Y. Patent No. 1,116,165.

The object of this invention is to provide a new and improved diaphragm for sound reproducers such as are used in gramophones, graphophones, receivers and transmitters of telephones and other sound-reproducing instruments and machines, and which is exceedingly sensitive for the reproduction of sound vibrations.

In order to accomplish the desired result use is made of a diaphragm of metal made exceedingly dense or compact throughout by pounding, beating, pressing, hammering or similar processes.

Figure 1 is a face view of the diaphragm as applied to a graphophone sound box shown in dotted lines; Fig. 2 is an enlarged cross section of

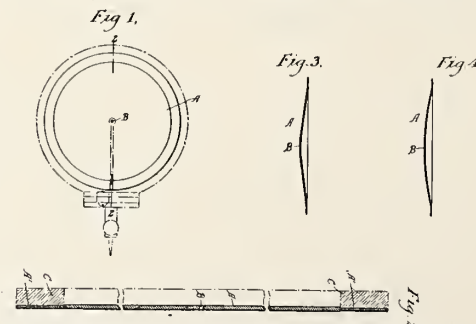

the diaphragm on the line 2—2 of Fig. 1, and showing in dotted lines the ring for compacting the peripheral edge of the diaphragm, and Figs. 3 and 4 are cross sections of diaphragms of different shapes.

DIAPHRAGM FOR SOUND REPRODUCERS.—Frederick W. Thomas, New York, N. Y. Patent No. 1,116,166.

This invention relates to a diaphragm for sound recorders and reproducers and is especially adapted for use in phonographs, graphophones and the like.

At the present time mica diaphragms are in universal use for phonographic sound recorders and reproducers, although numerous other types of diaphragms have been proposed, and among these others are metallic diaphragms variously corrugated or indented for the purpose of obtaining a

reproduction or recording of sounds equivalent to that obtainable with mica, the aim being to obtain a cheap substitute, as mica is expensive in the present condition of the market. Corrugated metallic diaphragms are unsatisfactory for various reasons, but mainly on account of their weakness at the central part where buckling occurs, thus showing a lack of strength of material or required stiffness. According to another type of diaphragm, the diaphragm is flat throughout its area and the metal pounded to strengthen the diaphragm by compacting the material, and then the diaphragm is nickel-plated to prevent corrosion or affection by the elements. Such metal diaphragms being of the same thickness from center to edge are unsatisfactory because of the lack of stiffness at the center, and, furthermore, because of the coating of nickel-plate, which materially interferes with the tonal qualities.

It is the object of the present invention to overcome the objections above noted by producing a metallic diaphragm which in recording and reproducing qualities is superior to mica, far less expensive, smaller in size for the same capacity of sound reproducing and recording, and which is practically indestructible, whereas mica diaphragms are of very short life because of their laminated structure, which results in the separation of the laminae by the vibratory action.

In carrying out the invention any suitable metal may be employed that is practically unaffected by the weather and temperature changes, such metals being gold, silver, platinum, antimony, tin, aluminum and the like, and alloys of such metals. Blanks cut from sheets of metal and preferably in the form of discs are subjected to a pounding, hammering or other compressing or compacting operation, whereby the metal is compacted and the air in the pores excluded. The pounding or hammering

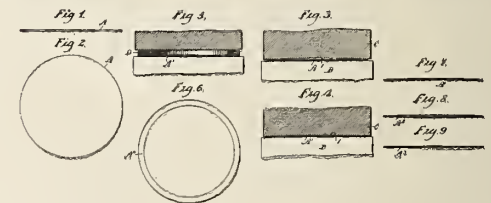

is so carried out that the resulting diaphragm will be of somewhat greater thickness at the middle than at the periphery, there being a gradual and uniform diminution of thickness from the center outwardly. During the shaping of the diaphragm the metal spreads radially, whereby the diaphragm acquires the required stiffness or rigidity and entirely overcomes any tendency to buckle. In other words, the diaphragm is of uniformly increasing strength from the supported periphery to the unsupported center.

When the diaphragms are made of certain kinds of metals it has been found beneficial to subject the diaphragm to a bath of cyanid of potassium, which tempers and strengthens the metal. It may also be necessary in some instances to increase the stiffness or rigidity of the diaphragm, after it has been acted on by the pounding or hammering dies which produce the uniform decrease in thickness from the center to the periphery, by stamping the entire peripheral portion of the diaphragm by means of an annular die which effects a radial expansion and hence radial stress because of the flow of metal outwardly in radial directions.

In the accompanying drawings, wherein similar reference characters designate corresponding parts throughout the several views, Fig. 1 is a side view of a blank of metal from which a diaphragm is made; Fig. 2 is a plan view thereof; Fig. 3 is a view showing the blank in the initial stage being hammered; Fig. 4 is a similar view showing the final stage of pounding or hammering the diaphragm; Fig. 5 is a view showing the manner of compressing the peripheral portion of the hammered diaphragm; Fig. 6 is a plan view of the diaphragm resulting from the operation shown in Fig. 5; Fig. 7 is a sectional view of the finished diaphragm having one side flat and the other side convex; Fig. 8 is a sectional view of a diaphragm convex on both sides; and Fig. 9 is a sectional view of a diaphragm which tapers from the center to the periphery on straight lines.

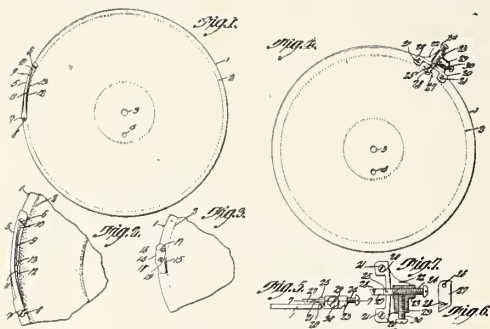

tion and guiding of the stylus. This substance is provided with means for insuring the direction of the stylus into the sound groove, at its beginning or at any "lead in" point of such groove. This feature cannot be too greatly emphasized, for where the record is used in a booth with a motion picture machine projector, a stylus positioning and guiding means must itself be durable and the record at the starting point must be reinforced to withstand the resulting hard usage. By making the guide a projection above the record surface, a means by which the operator may "feel" the position for inserting the stylus in the dim or no light of the booth is afforded, and thus at all times is provided means whereby the proper positioning of the stylus is assured.

In the drawings, Fig. 1 is a plan view of a disc record with one form of the present invention applied thereto. Fig. 2 is a fragmentary portion of the disc showing the structure as shown in Fig. 1 upon a larger scale. Fig. 3 is a view similar to Fig. 2 showing a modified construction of the present invention. Fig. 4 is a view similar to Fig. 1 showing another modified construction of stylus guiding and starting device or attachment. Fig. 5 is a side elevation of the device with a portion of the record in elevation. Fig. 6 is a detail view of the pivoted stylus starting and guiding member thereof. Fig. 7 is a section taken on line 7—7 of Fig. 5.

GRAPHOPHONE AND GRAMOPHONE SOUND BOX.—

LATEST PATENTS RELATING TO TALKING MACHINES—(Continued from page 52).

REPEATING DEVICE FOR TALKING MACHINES.—Lawrence Abraham, New York. Patent No. 1,117,143.

This invention relates more particularly to a device for use in connection with disc record machines, although a device of similar nature can be arranged in connection with the records of various makes of machines.

This device is shown as applied to the well-known Victor talking machine and has for its object to adapt the machine to repeat the playing of the record by automatic means requiring no attention

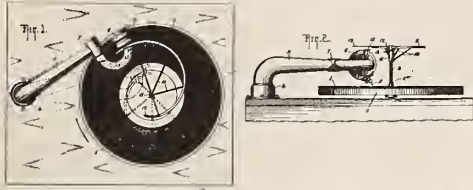

on the part of the operator other than keeping the motor going. This device when properly applied will also prevent the scraping of the needle after a record is played if the operator should neglect to lift the needle from the disc.

One form of this device as adapted to the Victor machine is illustrated in the accompanying drawings, of which Fig. 1 is a plan view and Fig. 2 a side view.

TALKING MACHINE.—Charles L. Hibbard, Philadelphia, Pa., assignor of one-half to Frederick W. Hager, same place. Patent No. 1,118,902.

This invention relates generally to talking machines and has particular reference to the construction and arrangement of the sound amplifier employed in connection therewith.

The object of the invention is to simplify and re-

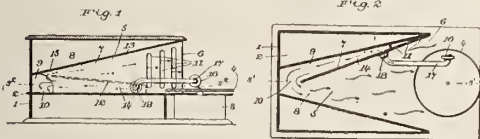

duce the cost of the machine, and at the same time give the reproduced sound improved tone quality and greater volume and clearness.

In the drawings—Fig. 1 is a central longitudinal section, taken on the line S¹, S¹ of Fig. 2 and Fig. 2 is a horizontal section, taken on the line S², S² of Fig. 1.

DIAPHRAGM.—James W. Owen, Lansdowne, Pa., and Albertis Hewitt, Camden, N. J., assignors to the Victor Talking Machine Co., Camden, N. J. Patent No. 1,118,675.

This invention particularly relates to diaphragms for sound recording and reproducing devices, such as are preferably adapted to talking machine construction.

The principal objects of this invention are, to provide a diaphragm that will respond with perfect clearness to the most delicate vibrations, irrespective of any atmospheric changes, and that will accurately record and reproduce both the high and low-tones and the included range with equal effect; and to provide a diaphragm which not only has the characteristics essential to the best reproduction of clear, loud and distinct tones, but combines therewith durability and stability, together with cheapness of manufacture in any desired quantities.

In the accompanying drawing, Fig. 1 is a front elevational view of the simplest form of this in-

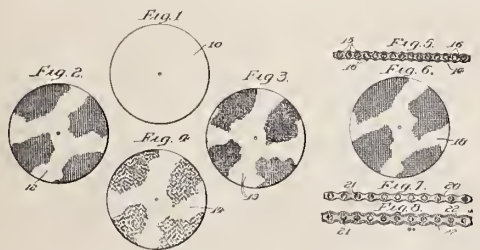

vention; Fig. 2 is a front elevational view of a diaphragm formed of fine woven fabric; Fig. 3 is a view similar to Fig. 2, showing the fabric treated with an electrically conductive material; Fig. 4 is a view similar to Figs. 2 and 3, showing the fabric diaphragm having an integument of metal; Fig.

5 is a fragmentary transverse section view of the diaphragm shown in Fig. 4; Fig. 6 is a front elevational view of a diaphragm similar to the diaphragm shown in Fig. 2, but of a relatively coarser fabric; Fig. 7 is a fragmentary transverse sectional view of the diaphragm shown in Fig. 6 showing its interstices provided with a filling, and Fig. 8 is a fragmentary transverse sectional view similar to Fig. 7, showing a dermatoid metallic integument formed therewith.

SOUND BOX FOR TALKING MACHINES.—Alva D. Jones, Philadelphia, Pa. Patent No. 1,118,653.

In sound boxes for talking machines, as generally constructed, the sound reproducing diaphragm is detachably held in position by one or more detachable annuli of rubber or similar material and the sound box is composed of a plurality of metallic and rubber parts united together by screws, the various parts having rubber insulation between them, whereby the cost of production is greatly increased.

It is further well-known that most sound boxes in use frequently emit a metallic or scratchy sound accompanying the reproduction of sound from the sound reproducing tablet. By the present invention, the entire sound box body is constructed of a single body of rubber or similar suitable material, the main body portion of the box having attached thereto by an annular, resilient, integral hinge, a front annular bead, having a diaphragm seat therein, said bead being softer or semi-cured with respect to the sound box body, which latter is harder or cured to a harder degree than said front annular bead containing the diaphragm seat.

It has been discovered as the result of an extensive series of experiments, that rubber when properly cured to the requisite degree, possesses many characteristics of the human throat when employed for a sound reproducing agent, and by constructing the entire sound box body of rubber and mounting the diaphragm in a seat within the front annular bead, which is softer than the sound box body, there is produced a device whereby the sound delivered from the diaphragm is greatly mellowed and improved, and a clear and distinct articulation obtained, provision thus being made for the diaphragm to be yielding supported so that it has capacity for vibration adjacent to its perimeter as

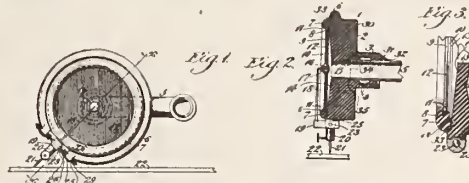

well as its center, the novel sound box and its adjuncts being inexpensive to construct, sensitive in action, easily and quickly repaired and readily accessible for the purpose of inspection or replacement of parts, means being thus provided for a general improvement of the tones, amelioration of the scratchy, metallic or grinding sounds common in instruments of this class, and provision being thus made for a faithful development and reproduction of the delicate sounds ordinarily difficult to reproduce, which are reproduced by this device with a maximum degree of fidelity and faithfulness to the original.

To the above ends, this invention consists of a novel construction of a one-piece sound box composed of rubber or similar material, wherein the body portion is thickened and cured to the requisite degree of hardness, said body portion having integral with or secured to the front portion thereof, an annular bead encircling and containing the diaphragm, the material of which said bead is composed being softer than the body of the sound box, whereby the requisite capacity for the vibration of the diaphragm at its outer and intermediate portions is provided.

It further consists of a novel construction of a sound box having a one-piece body of rubber or similar material of varying degrees of hardness, within the softer portion of which the mica or other diaphragm is cast or molded, without necessitating the employment of extraneous fastening devices.

Fig. 1 represents a side elevation of a sound box for talking machines, gramophones, graphophones and the like, embodying the invention. Fig. 2 represents a section on line x-x Fig. 1. Fig. 3 represents a view similar to a portion of Fig. 2, showing the sound box on an enlarged scale.

SOUND BOX FOR REPRODUCING AND RECORDING SOUND WAVES.—Robert L. Gibson, Philadelphia, Pa. Patent No. 1,118,647.

This invention has reference to sound boxes for reproducing and recording sound waves, and consists of certain improvements.

This application is a division of application Serial No. 372,432, filed May 7, 1907.

The object of the invention is to provide a suitable manner of supporting the vibrating diaphragm with which the stylus bar connects, whereby the extreme perimeter or circumferential edge of the diaphragm will alone be held in engagement with the ring or casing of the sound box, and by reason of which the vibrations of the diaphragm will be independent of the elasticity of any intermediate supporting means in the plane of the vibrations such as have been heretofore employed and which cover a material portion of the face of the diaphragm.

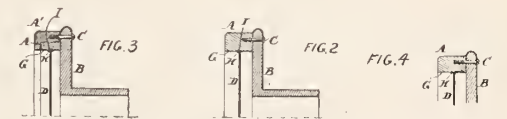
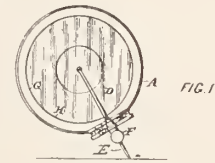

This invention consists in providing a metallic ring portion which may be secured to or form a part of the case of the sound box in which the interior diameter is accurately formed, so as to cooperate with the extreme outer edge or perimeter of the diaphragm so as to hold the same definitely in position by a slight clamping action upon substantially the entire perimeter of the diaphragm, whereby the entire diaphragm is free to vibrate, while at the same time the perimeter is practically held against movement.

More specifically, this invention consists in providing the interior surface of the ring of such a construction that different portions thereof have different diameters, and by means of which the diaphragm may be crowded into position so as to be held at its extreme perimeter at one definite place within the ring, and in interposing between the perimeter of the diaphragm and that portion of the ring which it is to engage, an exceedingly thin layer of yielding material, whether of textile or other material, which while not having any material elasticity will form a better binding union between the extreme outer circumference of the diaphragm and the metal ring which supports it.

Fig. 1 is a front elevation of a sound box, embodying these improvements; and Figs. 2, 3 and 4 are enlarged cross sections showing definite manners of uniting the ring and diaphragm, embodying the invention.

60 YEARS' EXPERIENCE

PATENTS

TRADE MARKS
DESIGNS
COPYRIGHTS & C.

Anyone sending a sketch and description may quickly ascertain our opinion free whether an invention is probably patentable. Communications strictly confidential. HANDBOOK on Patents sent free. Oldest agency for securing patents. Patents taken through Munn & Co. receive special notice, without charge, in the

Scientific American.

A handsomely illustrated weekly. Largest circulation of any scientific journal. Terms, \$3 a year; four months, \$1. Sold by all newsdealers.

MUNN & Co. 361 Broadway, New York
Branch Office: 625 F St., Washington, D. C.

RECORD BULLETINS FOR JANUARY, 1915.

VICTOR TALKING MACHINE CO.

No.	SONG HITS OF THE MONTH.	Size.
17629	Meet Me in Blossom Time (Moriarty-Shannon) Oakland-Campbell-Burr I Am Longing for the Days that Might Have Been (Jacobus-Sclden-Doyle)	10
17653	You're Always Welcome at Our House (Wm. Tracy-Al Harriman) Underneath the Japanese Moon, from "Follies of 1914" (Gene Buck-W. Gus Haenschen)	10
17655	He's a Rag Picker (Irving Berlin) Peerless Quartet Poor Pauline (Charles McCarron-Raymond Walk- er) Billy Murray	10
17657	The Memphis Blues (W. C. Handy) Morton Harvey The Mississippi Barbecue (Dave Reed) Collins and Harlan	10
17659	Sister Susie's Sewing Shirts for Soldiers (R. P. Weston-Herman E. Darewski) Now I'll Raise an Army of My Own (Roger Lewis-Ernie Erdman) Billy Murray	10
17666	Back to the Carolina You Love (Grant Clarke- Jean Schwartz) Peerless Quartet Tennessee, I Hear You Calling Me (Harold A. Robe-Jeff Godfrey) American Quartet	10
17666	Parisimo One-step (Charles E. Roat) Victor Military Band Jamaic Trop (Never Too Much) One-step (Otto Frey) Victor Military Band	10
17604	Metropolitan Hits—Medley One-step (Accordeon) Pietro Deiro Corker Medley One-step (Accordeon) Pietro Deiro 35419 Humpty Dumpty—Fox Trot (C. Straight-Arr. W. C. O'Hare) Victor Military Band Spookville Chimes—Fox Trot (Theo Morse) Victor Military Band	12
35422	Hits of 1915—Medley Fox Trot My Tango Girl—Fox Trot (Louis Hirsch) Victor Military Band	12
17665	The Sparkling Moselle, from "Papa's Darling" (Harry B. Smith-Ivan Caryl) O. Kline-H. Macdonough with Lyric Quartet Love Moon—Waltz Song, from "Chin Chin" (Anne Caldwell-Ivan Caryl) Olive Kline and Lyric Quartet	10
35420	The Life of Our Lord (Bible Story) Pauline Potter David and His Brethren (Bible Story) Pauline Potter	12
17658	Mr. Dooley's Address to the Suffragists Steve Porter Fall in Line (Suffrage March) (Zena S. Hawn) Victor Military Band	10
17671	Home, Sweet Home—Transcription (Celeste Solo) Felix Arndt Scotch Songs—Transcription (Celeste Solo) Felix Arndt	10
PATRIOTIC AIRS OF GERMANY, AUSTRIA, FRANCE AND BELGIUM.		
17668	La Marseillaise—National Air of France Sousa's Band	10
	Belgium—National Air (La Brabanconne) Victor Military Band	10
17669	Die Wacht am Rhein (Watch on the Rhine)—National Air of Germany (Carl Wilhelm) Sousa's Band Austrian National Hymn (Gott erhalte Franz den Kaiser) (Austrian Hymn) Victor Military Band	10
17670	Die Wacht am Rhein (Watch on the Rhine) (C. Wilhelm) In German Carl Schlegel Deutschland, Deutschland, über Alles (German National Song) (Joseph Haydn) In German Carl Schlegel	10
85397	Die Walküre—Magic Fire Scene (Wagner) Vessella's Italian Band	12
	Rienzi Overture (Wagner) A. Pryor's Band	12
17656	Krupp March (Wilhelm Wack) United States Marine Band Grand Duke of Baden March (Teike) United States Marine Band	10
35413	Gems from Robin Hood (Part 1) (H. B. Smith- Reginald de Koven) Victor Light Opera Co. Gems from Robin Hood (Part 2) (H. B. Smith- Reginald de Koven) Victor Light Opera Co.	12
NEW EDUCATIONAL RECORDS.		
17662	(1) Come Away, Death, from "Twelfth Night" (A. Barrat) (2) Take, Oh Take, Those Lips Away, from "Measure for Measure" (J. Wil- son) ("Songs from Shakespeare") (Harp ac- companiment) Raymond Dixon Oh, Mistress Mine, from "Twelfth Night" (Music by Thomas Morley (Songs from Shake- speare") (Harp accompaniment) Raymond Dixon	10
17634	Who is Sylvia? (F. Schubert) from "Two Gentle- men of Verona" (Baritone Solo with harp) Reinold Werrenrath It Was a Lover and His Lass, from "As You Like It" (Music by Thomas Morley) ("Songs from Shakespeare") (Unaccompanied) Raymond Dixon-Harry Macdonough	10
17663	Good News (Old Negro Spiritual) (Unaccom- panied) Tuskegee Institute Singers Live a Humble (Old Negro Spiritual) (Unaccom- panied) Tuskegee Institute Singers	10
17645	(1) Jack in the Pulpit, (2) In the Belfry, (3) Corn Soldiers, (4) Naming the Trees, (5) The Squirrel, (6) The Windmill, from "New Song Book and Music Reader" (Fullerton & Gray) (with piano) Olive Kline (1) Riggetty Jig, (2) The Singing School, (3) Dancing Song, (4) Dancing in May, (5) Mother Goose Lullaby, from "New Song Book and Music Reader" (Fullerton & Gray) (with piano) Olive Kline	10
PURPLE LABEL RECORDS.		
60112	We Take Off Our Hats to You, Mr. Wilson! Blanche Merrill	10
60127	I Work Eight Hours, Sleep Eight Hours, That Leaves Eight Hours for Love Ted Snyder	10

60128	A Birthday. Soprano Solo by Florence Hinkle, Poem by Christina Rossetti; music by R. Hunt- ingdon Woodman	10
70109	The Garden by the Sea (O'Way Thorps-Francis Lloyd) Baritone Solo George MacFarlane THE JANUARY RED SEAL RECORDS.	12
64429	Golden Love, (Mary Mark Lemon-Milton Wellings) Tenor Solo in English John McCormack	10
64439	Hungarian Dance No. 7 (with pianoforte) (Brahms-Joachim) Violin Solo Mischa Elman	10
64450	Solitude (poem by T. d'Offoe) to Rubinstein's "Melody in F." Soprano Solo in French, with Balaika Orchestra—Pianoforte by Frank La Forge Frances Alda	10
64457	Barcarolle—Tales of Hoffman. (Offenbach) Vi- olin Solo Maud Powell	10
64470	Thy Beaming Eyes, Op. 40, No. 3 (Poem by W. H. Gardner; Music by E. A. MacDowell). Con- tralto Solo in English; Pianoforte by Rosario Bourdon Sophie Braslau	10
74406	Parsifal—Amfortas' Gebet, "Mein Vater!" (Am- fortas' Prayer, "My Father") (Act III) Bari- tone Solo, in German (Wagner) Clarence Whitehill	12
74417	One Sweetly Solemn Thought (Sacred Song (Phoebe Cary-Paul Ambrose) Bass Solo, in English Herbert Witherspoon	12
74419	The Death of Nelson (John Braham) Tenor Solo, in English Evan Williams	12
87143	Thais—Aria Alessandria—Ecco la terribile citta (That Awful City I Behold) (Act I) (Mas- senet) Baritone Solo, in Italian Tiuta Ruffo	10
87184	Der Jäger lang dem Weiher ging (Hunter's Song) (Folk Song) (Pax. Arr. Wilhelm Ber- ger) Soprano and Tenor Duet, in German Alma Gluck and Paul Reimers	10
87191	Serenade, "Softly Through the Night is Calling" (Mattellath-Schubert) Tenor Solo in English; Pianoforte by Vincent O'Brien John McCormack and Fritz Kreisler (Violin)	10
87201	Life's Dream Is O'er (Music to "Alice Where Art thou?") (Arr. by S. G. Pratt) Soprano and Contralto Duet, in English Alma Gluck and Louise Homer	10
88469	Aida—O patria mia (My Native Land) (Act III) (Verdi) Soprano Solo, in Italian Emmy Destinn	12
88492	Le Carillon de Cythère (The Chimes of Cythéra) (F. Couperin) Piano Solo Ignace Jan Paderewski	12
88503	Carmen—Micaela's Air (I Am Not Faint-Heart- ed) (Bizet) Soprano Solo, in Italian Louisa Tetrazzini	12

COLUMBIA GRAPHOPHONE CO.

No.	SYMPHONY DOUBLE-DISC RECORDS.	Size.
A5612	Mary (Richardson). Soprano Solo in English, with orch. accomp. Bernice de Pasquali Swiss Echo Song (Eckert) Soprano Solo, in English, orch. accomp. Bernice de Pasquali	12
A5610	Tannhauser (Wagner). "O Star of Eve" Baritone Solo in English, orch. accomp. Charles W. Clark	12
	Herodiade (Massenet). "Vision Fugitive" (Fleeting Vision). Baritone Solo in French, orch. accomp. Charles W. Clark	12
BLUE-LABEL DOUBLE-DISC RECORDS.		
A1616	Aloha Oe (Liliuokalani) Toots Paka Hawaiian Company Hawaiian Medley Toots Paka Hawaiian Co.	10
A1618	Lucia di Lammermoor (Donizetti) "Tomba degli avi miei" (Tombs of My Ancestors). Tenor Solo in Italian, orch. accomp. Manfredi Polverosi	10
	Traviata (Verdi). "Parigi o cara" (Far from the Parisian Throng). Soprano and Tenor duet in Italian, with orch. Ida Cattorini, soprano, and Angelo Bendinelli, tenor.	10
A1621	Revival Day (Berlin). Baritone Solo, orch. ac- comp. Al Jolson Back to the Carolina You Love (Schwartz). Bari- tone Solo, orch. accomp. Al Jolson	10
A1622	A Perfect Day (Jacobs-Bond) Columbia Mixed Quartet	10
	Oh Fair, Oh Sweet and Holy (Cantor). G. Stehl, violin; M. P. Lufsky, flute; C. Schuetze, harp	10
DOUBLE-DISC RECORDS.		
A1582	What a Friend Thou Art to Me (Main). Chautauqua Preachers' Quartet Glorious Things of Thee Are Spoken (Towner). Chautauqua Preachers' Quartet	10
A1585	Why Did He Die? (Owen) Chautauqua Preachers' Quartet I Want My Life to Tell (Lorenz) Chautauqua Preachers' Quartet	10
A1584	Let the Lower Lights Be Burning (Bliss) Chautauqua Preachers' Quartet Softly Now the Light of Day (Gottschalk) Chautauqua Preachers' Quartet	10
A1585	Hold the Fort (Bliss) Chautauqua Preachers' Quartet The Wayside Cross (Palmer) Chautauqua Preachers' Quartet	10
A1610	Still, Still With Thee (Garrison) Chautauqua Preachers' Quartet Remember Me, Oh Mighty One (Kinkel) Chautauqua Preachers' Quartet	10
A1617	It Was a Lover and His Lass (German). Con- tralto and Baritone Duet, in English, orch. accomp. Carrie Herwin and George Baker Whisper and I Shall Hear (Piccolomini). Con- tralto and Baritone Duet, in English, orch. accomp. Carrie Herwin and George Baker	10
A1619	Henry VIII Suite (German). Morris Dance Columbia Orchestra Henry VIII Suite (German). Shepherd's Dance Columbia Orchestra	10
A1620	It's a Long, Long Way to Tipperary (Williams). Prince's Band with Chorus of Men's Voices Red, White and Blue (Shaw) Prince's Band	10

The Prize Song of the Panama-Pacific Exposition Song
Contest Conducted by the San Francisco Bulletin

A1623	Nineteen-Fifteen San Francisco (Jacoby). Tenor Duet, orch. accomp. A. Campbell (1st), H. Burr (2d) I Love You, California (Frankenstein) Prince's Orchestra	10
A1631	Jackanapes Polka. Concertina Solo Chicago Schottische (Clifford). Concertina Solo. Alexander Prince	10
LATEST SONG HITS.		
A1625	When It's Night Time Down in Burgundy (Paley.) Orch. accomp. Columbia Stellar Quartet	10
	The Dress My Mother Wore (Sunshine and Mar- shall). Tenor and Baritone Duet, orch. accomp. Charles W. Harrison and Andrea Sarto	10
A1624	Chinatown, My Chinatown (Schwartz). Soprano and Tenor Duet, orch. accomp. Grace Kerns and John Barnes Wells	10
	Mrs. Sippi, You're a Grand Old Girl (Ashlyn). Columbia Stellar Quartet	10
A1626	Do the Funny Fox Trot (Carroll and Carroll) Baritone and Tenor Duet, orch. accomp. Arthur Collins and Byron G. Harlan	10
	Poor Pauline (Walker). Baritone Solo, orch. ac- comp. Arthur Fields	10
A1627	In the Garden (Lange). Soprano and Tenor Duet, orch. accomp. Ada Jones and George W. Ballard	10
	It's a Very Easy Thing to Put a Ring Upon a Finger (Grant). Baritone and Tenor Duet, orch. accomp. A. Collins and B. G. Harlan	10
A1628	He's a Rag Picker (Berlin). Orch. accomp. Peerless Quartet Stay Down Where You Belong (Berlin). Baritone Solo, orch. accomp. Arthur Fields	10
A1630	In Siam (Klein). Tenor Solo, orch. accomp. Henry Burr	10
	The Red, White and Blue (New Ballad) (Hirsch). Orch. accomp. Peerless Quartet	10
A5611	Jewels of the Madonna (Wolf-Ferrari). Intro- duction to Act II Prince's Orchestra Jewels of the Madonna (Wolf-Ferrari). Intro- duction to Act III Prince's Orchestra	12
A5614	Clammy Green Golden and Hughes "I Don't Care If You Never Come Back" "Push Dem Clouds Away." "Good-bye, Manhattan Isle." Columbia Minstrels	12
DANCE RECORDS. RECORDING SUPERVISED BY G. HEPBURN WILSON, M.B.		
A5613	It's a Long, Long Way to Tipperary (Williams). One-step Prince's Band As You Please (Lamont). One-step Van Eps Banjo Orchestra	12
A5615	College Medley, No. I—One-step Prince's Band College Medley, No. II—One-step Prince's Band	12
A5616	Destiny Waltz (Baynes) Prince's Band Free and Easy (Berger). "Castle Polka" Prince's Band	12
A5617	Morning Exercise (Berlin). Fox Trot Prince's Band Love's Perfume (Parfum d'Amour) (Henry) Waltz-Hesitation Prince's Band	12
A1629	Soup to Nuts (Arndt). One-step Van Eps Banjo Orchestra I Want to Go Back to Michigan (Berlin). Fox Trot Van Eps Banjo Orchestra	10

EDISON BLUE AMBEROL RECORDS.

REGULAR LIST.	
2485	Boat with My True Love's Name (Collin Coe) Contralto and Baritone Duet, orch. accomp. Helen Clark and Vernon Archibald
2488	By the Setting of the Sun (Florence Gear) Tenor Solo, orch. accomp. Walter Van Brunt
2501	California and You (Harry Puck) Tenor Solo and chorus, orch. accomp. Billy Murray and Chorus
2509	Come Back to Me (C. Flavel Hayward) Contralto Solo and Chorus, orch. accomp. Mary Jordan and Chorus
2498	Comfort Ye, My People—Messiah (Handel) Tenor Solo, orch. accomp. Reed Miller
2484	Dost Thou Know that Sweet Land? (Connais tu le pays)—Mignon (Thomas) Contralto, orch. ac- comp. Marie Morrisey
2499	Ev'ry Valley Shall Be Exalted—Messiah (Handel) Tenor Solo, orch. accomp. Reed Miller
2494	Fairest Rose Waltz (H. Engelmann) Xylophone Solo, orch. accomp. Charles Daab
2496	Girl from Utah—One-step (Jerome D. Kern) (For Dancing) National Promenade Band
2490	I'm Goin' Back to Louisiana (E. Clinton Keithley) Tenor Solo and chorus, orch. accomp. Billy Murray and Chorus
2507	I Want to Go Back to Michigan (Irving Berlin) Tenor Solo and chorus, orch. accomp. Billy Murray and Chorus
2504	La Bohème Waltz Song (Puccini) Whistling Solo, orch. accomp. Guido Gialdini
2500	Leave Me to Languish—Recitative and Aria from Rinaldo (Handel) Soprano Solo, orch. accomp. Adelaide Fischer
2502	Love's Melody (Leo Daniderff) Tenor Solo and Chorus, orch. accomp. Elizabeth Spencer and Emory B. Randolph
2492	Lu Lu-Fado (Nicolino Milano) (For Dancing) National Promenade Band
2489	Meadowbrook Fox Trot (Arthur Kraus) (For Dancing) National Promenade Band
2495	Mrs. Sippi, You're a Grand Old Girl—Pretty Mrs. Smith (Belle Ashlyn). Contralto and Tenor Duet, orch. accomp. Helen Clark and Billy Murray
2493	My Dream of Dreams—Pretty Mrs. Smith (Car- roll and Robyn) Soprano Solo, orch. accomp. Marie Kaiser
2503	Ta-Tao One-step (Chinese Dance) (William H. Penn) (For Dancing) National Promenade Band
2505	Vulcan's Song (Gounod) Basso Solo, orch. ac- comp. T. Foster Why
2506	Weber's Last Thought—Fantasia (Weber) Cor- net Solo, orch. accomp. Gustav H. Heim
2510	When the Ebb-tide Flows (Stanley Gordon) Male voices Knickerbocker Quartet
2491	When the Green Leaves Turn to Gold (Ray- mond White) Soprano and Tenor Duet, orch. accomp. Elizabeth Spencer and W. Van Brunt
2497	When the Roses Bloom (Reichardt) Tenor and So- prano duet and chorus, orch. accomp. Emory B. Randolph, Elizabeth Spencer and Chorus
2508	(a) Yesterday and To-day (Spross); (b) Because (d'Hardeflot) Baritone Solo, orch. accomp. Charles N. Granville

CHEMISCHE FABRIK **E. SAUERLANDT** FLURSTEDT bei Apolda i. Th., Germany
The largest manufacturing plant in the world devoted exclusively to the
manufacture of Master-Waxes and Master-Blanks for
Gramophone and Phonograph Recording
Sole Manufacturer of Wax "P." the best recording material for Berliner-cut.

One piano house that some few seasons ago de-
cided not to continue the talking machine feature
of its business, i.e., the Carlin Music Co., of Indian-
apolis, Ind., has recently changed its attitude and
now re-enters the field, this time with the Edison
disc line exclusively.

\$ \$ \$ \$ \$ \$ \$ \$ \$

\$ \$ \$

\$ \$ \$

\$ \$ \$

\$ \$ \$

\$ \$ \$

READ your trade paper! Get The Talking Machine World regularly—It is worth many times to you its annual cost.

There is but one talking machine paper covering this entire industry, and it is admitted by all that it is of great aid to the dealers in every part of this country.

New economic conditions make certain knowledge necessary on the part of merchants, and in every issue of The World there is contained educational matter, instructive service, business news and technical articles which are worth many times the cost of the paper.

Thousands have been benefited by the business articles which appear in The World, and every talking machine dealer should receive it regularly.

The only way to do that is to pay for it, and the cost is trifling—a little over eight cents a month, and for that small sum The World, with all its mine of information, is at your service.

If you do not receive the paper regularly just put your dollar in an envelope and address it to the office of the publication, and you will say that it is the best investment that you have ever made.

Do not delay but send on your dollar now.

Recollect that your competitor is getting The World—getting it regularly, and in it he is securing some valuable pointers—information which places you at a disadvantage if you do not read the paper.

Do not overlook such a valuable contributing factor to your business success.

EDWARD LYMAN BILL
PUBLISHER

373 Fourth Avenue

New York City



Price, \$35.00
Style "Jewel."

10 1/2" Turntable. Tone Modifier. Sapphire Needle. Double-spring Motor. Equipment for playing all makes of disc records in the world. (Diamond Needle \$5.00 extra; Multi-Playing Needle \$1.00 extra.) Trimmings Nickel-plated.

Tone Quality Universal Playing Motors of Power Precision and Individuality

These are some of the individual selling points of the Sonora. There are many other features, such as a Tone Modifier that modulates without muffling, an automatic Start and Stop, a filing system that preserves and keeps records for easy handling.

Our Policy—Exclusive Representation

Our policy is one dealer to a territory. It is an inviting proposition to be the only Sonora dealer in your city. Every prospect must come to you. And every Sonora sale is the first of a series. Satisfied customers talk about their Sonoras. Be the first in your field. Someone is going to be our exclusive dealer in your district—why not **you**?



Price, \$40.00
Style "Jewel Combination."
(Alhums Extra)

10 1/4" Turntable. Tone Modifier. Sapphire Needle. Double-spring Motor. Equipment for playing all makes of disc records in the world. (Diamond Needle \$5.00 extra. Multi-Playing Needle \$1.00 extra.) Trimmings Nickel-plated.

SONORA

PHONOGRAPHS

"The Highest Class Talking Machine in the World"
"Plays Perfectly All Makes of Disc Records"

The Sonora Phonograph Corporation has been the first to market a jewel disc record in this country—the first to offer a hornless machine under \$200—the first to perfect an automatic start and stop **that works**—the first to introduce an electric phonograph that does not require a mechanic to run it—the first to make a jewel needle to play all steel needle records without injuring the records.

Other great advantages in preparation for next season. We lead in many points where others follow—why not lead with us?

The Sonora line is a complete line, with styles from \$35 to \$200. Our policy is broad and liberal. Our dealers receive a good profit and co-operation. We have created a demand for Sonora instruments and solicit correspondence from reliable representatives.



Price, \$100.00
Style "Imperial."

12" Turntable. Extra Strong Double-spring Motor. Nickel plated. Tone Modifier. Multi-Playing Needle. Sapphire Needle. Diamond Needle. Automatic Starter and Stopper. Equipment for playing all makes of disc records in the world. Trimmings Nickel-plated. Envelope Filing System, with capacity for holding 70 records. Compartment at bottom of cabinet for accessories.

SONORA

Jewel Multi-Playing Needle

Plays hundreds of times without changing. Plays on all makes of machines. Plays all steel needle records. Saves the life of new records, preserves the life of old ones. Saves needle expense. Costs \$1.00.

Sonora Phonograph Corporation

57 Reade St.

New York City

GEO. E. BRIGHTSON, Pres.



Price, \$200.00
Style "Grand."

12" Turntable. Extra Heavy Double-spring Motor, playing half an hour, or ten 10" records, in one winding. Tone Modifier. Sapphire Needle. Diamond Needle. Automatic Starter and Stopper. Multi-Playing Needle. Equipment for playing all makes of disc records in the world. Trimmings Gold-plated. Envelope Filing System, with capacity for holding 160 records.





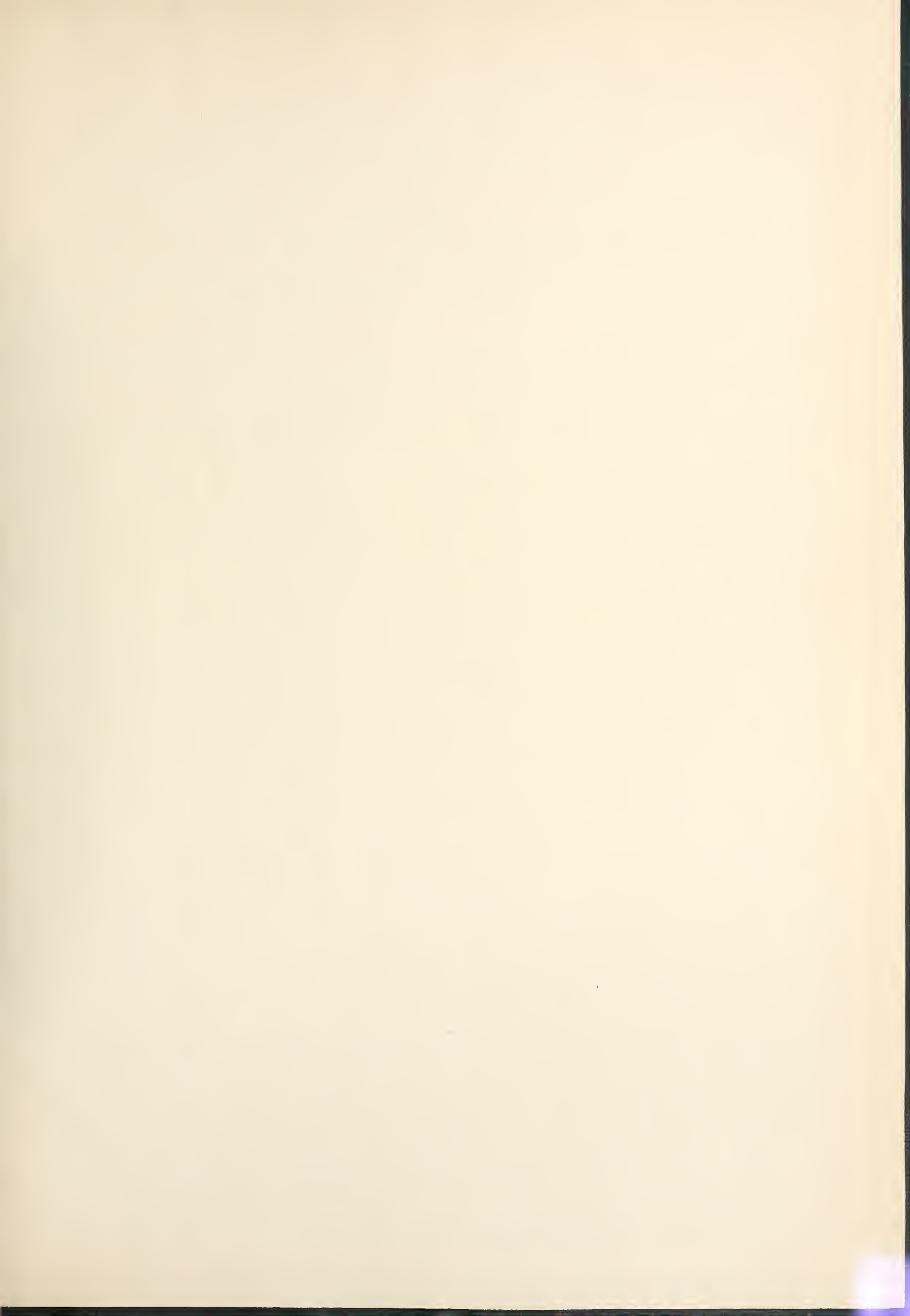

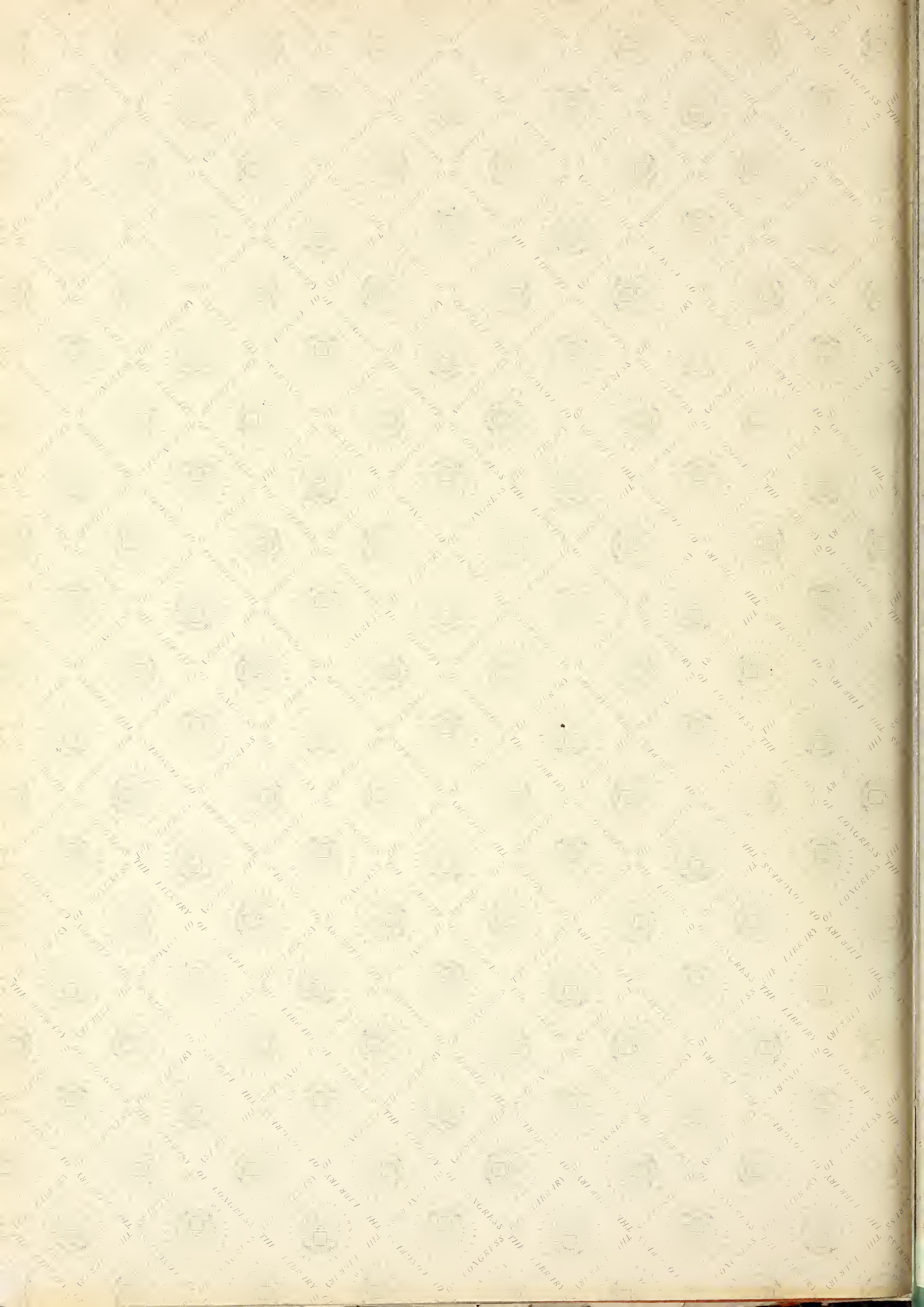

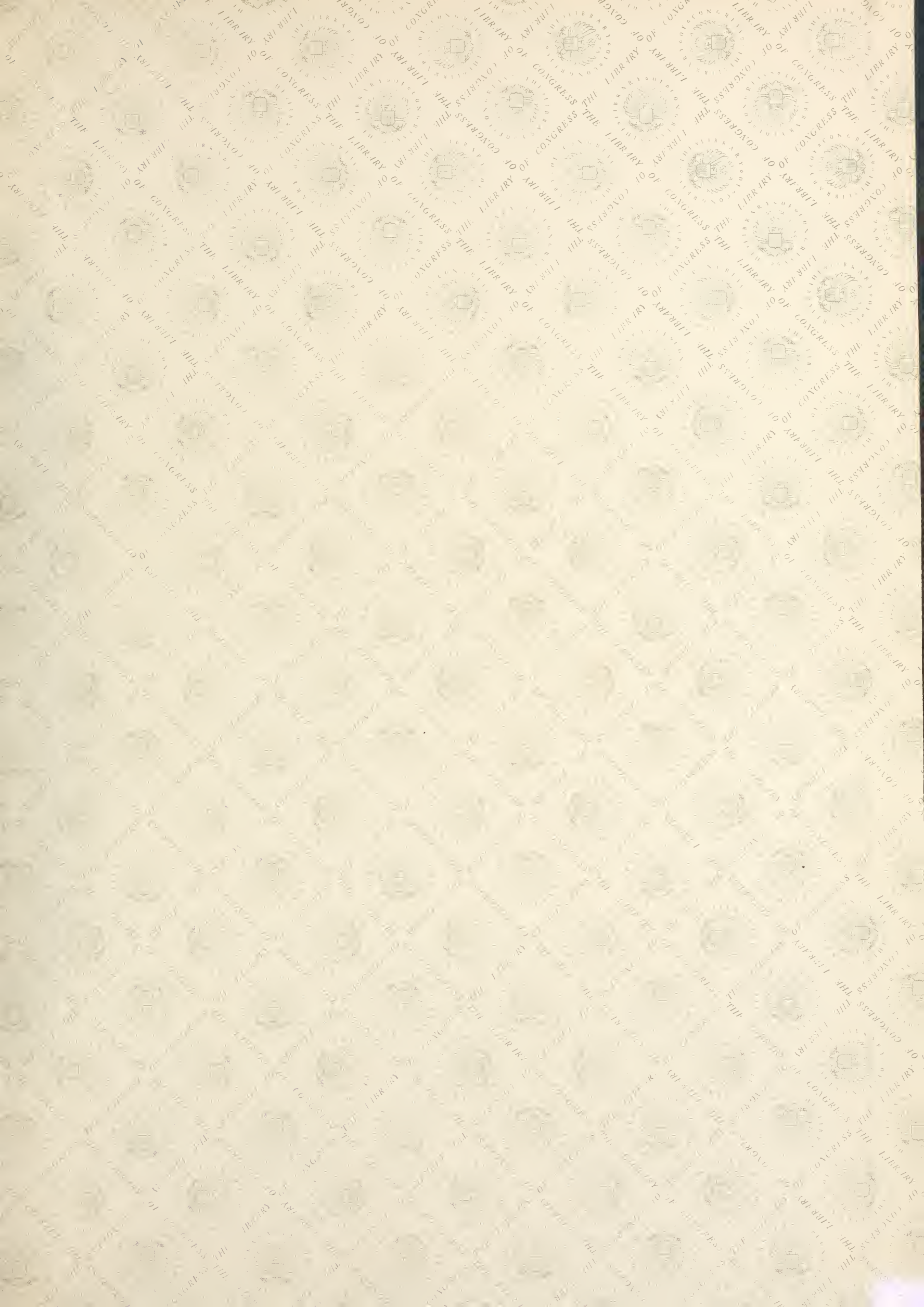

LIBRARY OF CONGRESS



0 021 248 800 8