

B 1.059.618

Q

1
P. 540

PHILIPPINE
JOURNAL
OF
SCIENCE

CHEMICAL AND
GEOL. SCIENCES

13

1918

UNIV.

OF

THE

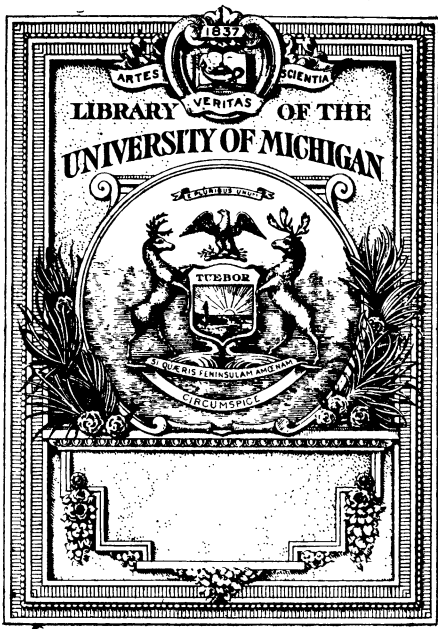

Q
1
.P549

THE PHILIPPINE JOURNAL OF SCIENCE

ALVIN J. COX, M. A., PH. D.

GENERAL EDITOR

SECTION A CHEMICAL AND GEOLOGICAL SCIENCES AND THE INDUSTRIES

EDITED WITH THE COÖPERATION OF

H. C. BRILL, PH. D.; J. R. WRIGHT, PH. D.; G. W. HEISE, M. S.

T. DAR JUAN, A. B., PHAR. D.; A. H. WELLS, A. B.

R. C. MCGREGOR, A. B.; H. E. KUPFER, A. B.

VOLUME XIII

1918

WITH 26 PLATES AND 62 TEXT FIGURES

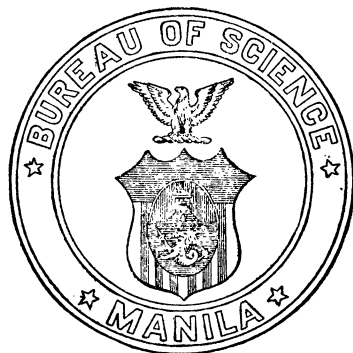

MANILA
BUREAU OF PRINTING
1918

DATES OF ISSUE

- No. 1, pages 1 to 48, February 17, 1918.
- No. 2, pages 49 to 98, June 7, 1918.
- No. 3, pages 99 to 145, June 7, 1918.
- No. 4, pages 147 to 216, December 19, 1918.
- No. 5, pages 217 to 274, February 1, 1919.
- No. 6, pages 275 to 368, May 20, 1919.

96.1
P 55
J 8

APR 6 1918

VOL. XIII, SEC. A, No. 1

JANUARY, 1918

THE PHILIPPINE JOURNAL OF SCIENCE

ALVIN J. COX, M. A., PH. D.
GENERAL EDITOR

SECTION A CHEMICAL AND GEOLOGICAL SCIENCES AND THE INDUSTRIES

EDITED WITH THE COÖPERATION OF

H. C. BRILL, PH. D.; J. R. WRIGHT, PH. D.; G. W. HEISE, M. S.
T. DAR JUAN, A. B., PH. D.; A. H. WELLS, A. B.
R. C. MCGREGOR, A. B.; H. E. KUPFER, A. B.

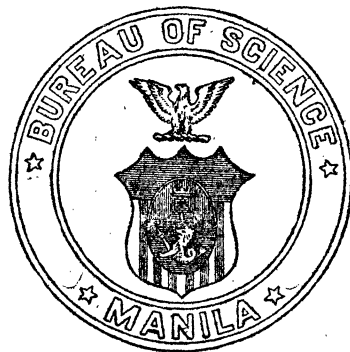

MANILA
BUREAU OF PRINTING
1918

PHILIPPINE JOURNAL OF SCIENCE

A TEN-YEAR INDEX

CONTENTS AND INDEX OF THE PHILIPPINE JOURNAL OF SCIENCE, VOLUME I (1906) TO VOLUME X (1915)

Order No. 449. Bureau of Science Publication No. 8. Paper, 441 pages.
Price \$2. United States currency, postpaid.

One copy of this index has been sent free of charge to each subscriber that has received Volumes XI and XII of the Journal.

This publication consists of:

The complete contents of the first ten volumes of the Philippine Journal of Science, all sections; giving all authors, titles of articles, and page numbers. The exact date of issue of each number is recorded.

An author index, being an alphabetical list of all the contributors. The titles of all the articles are listed under the names of their respective authors.

A subject index. The subject matter is very fully indexed by catch words from the titles, by geographical localities, and by subjects. All systematic names in zoölogy and botany, as well as the thousands of English and local names, are entered in the index.

STUDIES IN PHILIPPINE DIPTERA, II

By M. BEZZI

Order No. 437. Bureau of Science Publication No. 10. Paper, 59 pages and 1 plate.
Price \$0.50, United States currency, postpaid.

This is the second century of Professor Bezzi's enumeration of Philippine species of flies and includes descriptions of new genera and new species.

PLEASE GIVE ORDER NUMBER

Orders for Bureau of Science publications may be sent to the BUSINESS MANAGER, Philippine Journal of Science, Bureau of Science, Manila, P. I., or to any of the following agents:

AGENTS

THE MACMILLAN COMPANY, 64-66 Fifth Avenue, New York, U. S. A.
WM. WESLEY & SON, 28 Essex Street, Strand, London, W. C., England.
MARTINUS NIJHOFF, Lange Voorhout 9, The Hague, Holland.
KELLY & WALSH, Limited, 32 Raffles Place, Singapore, Straits Settlements.
A. M. & J. FERGUSON, 19 Baillie Street, Colombo, Ceylon.
THACKER, SPINK & Co., P. O. Box 54, Calcutta, India.

CONTENTS

No. 1, January, 1918		Page.
HEISE, GEORGE W., and BEHRMAN, A. S. Water analysis in the field. One plate.	1	1
BEHRMAN, A. S. Two field methods for the determination of the total hardness of water.....	21	21
WITT, J. C. Some generalizations on the influence of substances on cement and concrete.....	29	29
No. 2, March, 1918		
WRIGHT, J. R., and HEISE, G. W. The radium content of water from the China Sea..... Two text figures.	49	49
WITT, J. C. Methods of burning pottery in the vicinity of Manila and their influence on the quality of the product..... Two plates and one text figure.	59	59
COCANNOUER, JOSEPH A. Tests of some imported garden legumes...	67	67
REVIEWS	97	97
No. 3, May, 1918		
YCASIANO, FRANCISCO R., and VALENCIA, FELIX V. Practical opera- tion of a producer-gas power plant..... Nine text figures.	99	99
MIRASOL, JOSE Y JISON. Fertilizer experiments with sugar cane..... Two text figures.	135	135
No. 4, July, 1918		
WITT, J. C., and REYES, F. D. The solubility of Portland cement and its relation to theories of hydration..... One text figure.	147	147
REINKING, OTTO A. Philippine economic-plant diseases..... Twenty-two plates and forty-three text figures.	165	165
No. 5, September, 1918		
REINKING, OTTO A. Philippine economic-plant diseases (concluded)..	217	217
No. 6, November, 1918		
VALENCIA, F. V. Mechanical extraction of coir..... One plate.	275	275
KING, ALBERT E. W. The mechanical properties of Philippine coir and coir cordage compared with abacá (Manila hemp)..... Four text figures.	285	285
YCASIANO, F. R. A recalculation of certain data on steaming tests of Philippine coals.....	341	341
CONCEPCION, ISABELO. Analysis of normal Filipino urine.....	347	347
REVIEW	361	361
INDEX	363	363

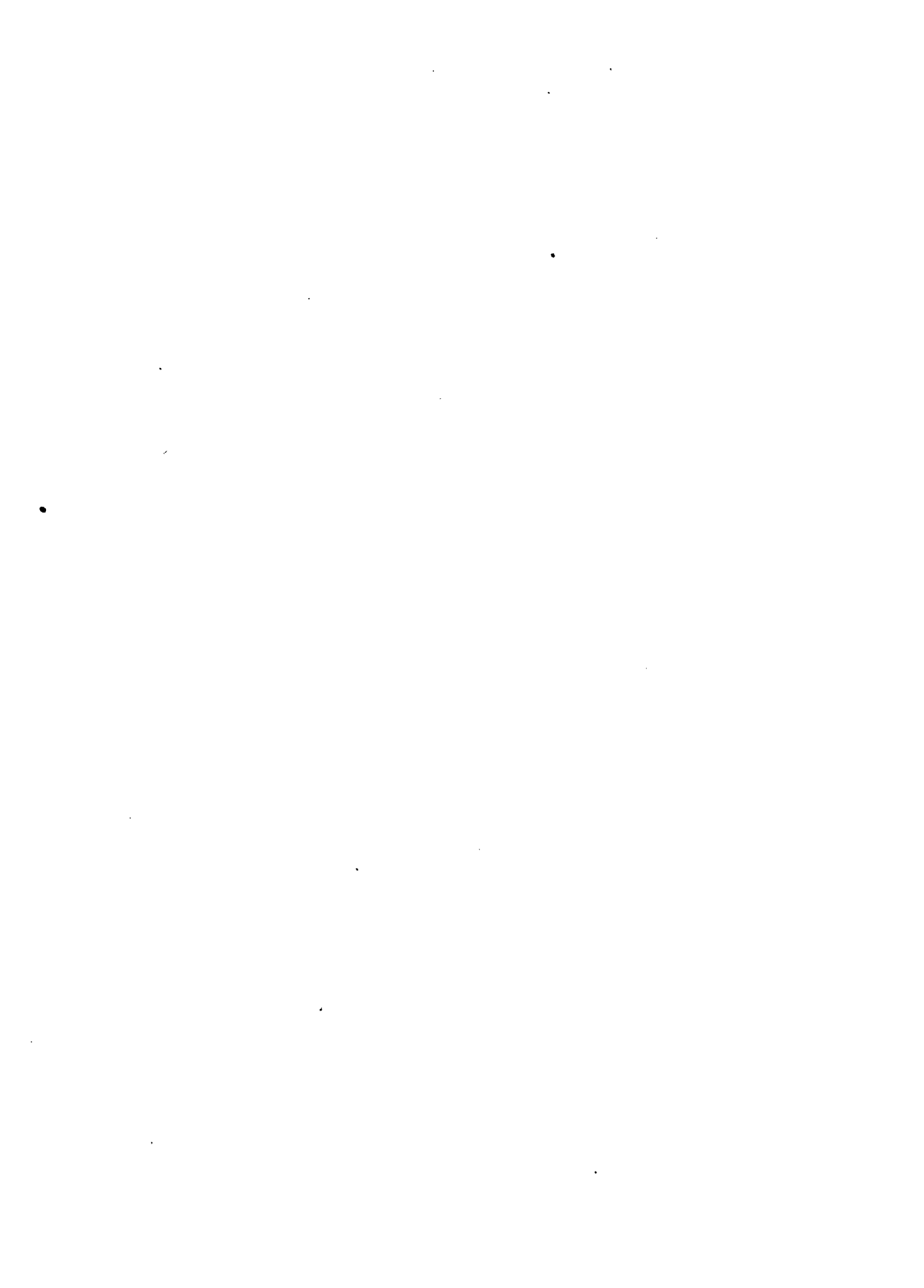

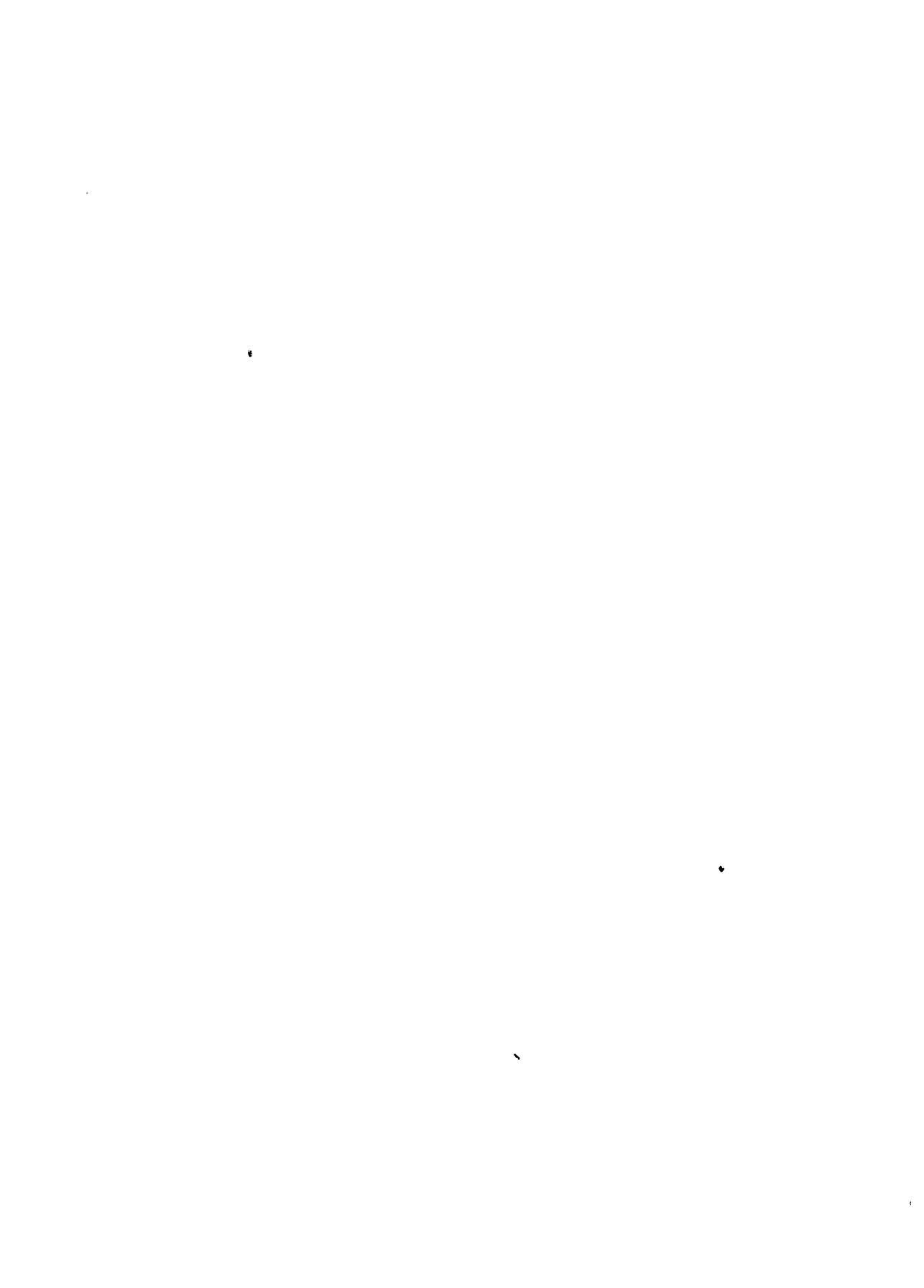

THE PHILIPPINE JOURNAL OF SCIENCE

A, CHEMICAL AND GEOLOGICAL SCIENCES
AND THE INDUSTRIES

VOL. XIII

JANUARY, 1918

No. 1

WATER ANALYSIS IN THE FIELD ¹

By GEORGE W. HEISE and A. S. BEHRMAN

*(From the Laboratory of General, Inorganic, and Physical Chemistry,
Bureau of Science, Manila)*

ONE PLATE

Recent developments in water analysis have emphasized the importance of making examinations at the source whenever possible. The work of the Bureau of Science has shown the need of field investigations and the peculiar applicability of field methods to Philippine conditions. Accordingly field work has been made one of the most important features of our study of water supplies.

Owing to the comparative isolation of the Philippines, the great distance from scientific or manufacturing centers, and the consequent loss of time when apparatus and supplies are procured from abroad, we have found it necessary, to a large extent, to build our own apparatus, to prepare our own reagents for field use, and to devise and adapt methods suitable to our needs.

The field work of the Bureau of Science has been carried on for three years. Because of the importance of field methods at the present time, and because workers in as isolated places as the Philippines will continue to be dependent, in a great measure, on their own resources, we have thought it advisable to describe our field methods and apparatus in detail.

Our methods are based upon those described by Leighton.² Several changes, however, have been made. A "tabloid" de-

¹ Received for publication August, 1917.

² Leighton, M. O., Field assay of water, *U. S. Geol. Surv., Water Supply Paper* (1905), No. 151.

termination of acidity and a rough estimate of the total amount of solid matter have been added, the soap method for total hardness has been replaced by a new and more accurate procedure, and several minor modifications in the details of manipulation of some of the old methods have been introduced. Other minor changes have been made in apparatus, as will become evident in the detailed description to follow.

In connection with the study of potable waters, a field bacteriological examination is also made. This consists in 24- and 48-hour colony counts at ordinary temperature and a presumptive test for *Bacillus coli* or related organisms that would indicate faecal contamination. The uniform tropical temperature (25° to 30° C.) makes this bacteriological work a very simple, while a very valuable, feature of the examination.

The outfit has been gradually reduced in size, although the number of determinations made has been increased; so now enough apparatus and materials for a month's chemical work can be carried in an army telescope. This makes a package weighing less than 20 kilograms, which fits well on one side of a packsaddle or on the back of a cargador. The bacteriological outfit is carried in a small metal box. The complete equipment is shown in Plate I.

A comprehensive sanitary survey, embracing, in so far as possible, all those features that might influence the quality of the water under examination, is, of course, included in field work.

The details of the methods employed in regular field examination are outlined and briefly discussed.

TABLE I.—*Chemical methods.*

Quantitative.	Qualitative.
Color	Odor
Turbidity (as SiO ₂)	Total solids
Alkalinity (as CaCO ₃)	Appearance on ignition
Acidity (as CO ₂)	Calcium
Iron (Fe)	Classification for boiler use
Chlorides (Cl)	
Normal carbonates (as Na ₂ CO ₃)	
Bicarbonates (as CaCO ₃ or HCO ₃) [by calculation]	
Sulphates (as SO ₃)	
Total hardness (as CaCO ₃)	
Estimated encrustants [by calculation]	

Color is determined with the United States Geological Survey color outfit described by Leighton,³ consisting of a standard

³ Op. cit.

length aluminium tube, which is filled with the water under examination. The color of this column of water, viewed longitudinally, is matched by disks of colored glass that have been rated in parts per million to correspond to the platinum-cobalt standard.

Iron is conveniently determined with the same outfit as used for color, as described by Leighton. The only extra equipment required is a series of prepared colored disks corresponding to those produced by treating standard solutions of iron. These disks have not been available. In lieu thereof, red and yellow glasses from the Lovibond tintometer have been employed, in connection with two matched Nessler tubes in galvanized iron outer tubes. When 100 cubic centimeters of water were used in a determination, it was found that a summation of 6.0 on the Lovibond scale was very nearly equal to 1 part per million of iron (as Fe). The following is the procedure employed:

To 100 cubic centimeters of the water under examination in a Nessler tube add 4 cubic centimeters of concentrated nitric acid. Mix thoroughly by pouring six or seven times from one tube to another and allow to stand at least five minutes to insure complete oxidation. Then add 6 cubic centimeters of a 2 per cent solution of potassium sulphocyanide, mix thoroughly by several pourings, and allow to stand ten minutes for the color to develop. Exactly at the end of ten minutes make the color comparison with the Lovibond glasses under the empty Nessler tube, using a piece of white paper to reflect the light. Hold the tubes with one hand sufficiently high to reflect all the light possible. Interchange the tubes several times to avoid inequalities of light. The tubes should be held in such a position that both may be seen with one eye. Obviously, the final reading may be made either by using all the glasses under the empty Nessler tube or with some under the water as well. In this way intermediate values sometimes not otherwise obtainable may be found.

In all cases the nitric acid used should be tested beforehand for iron, this being a not infrequent impurity.

Turbidity is determined with the electric turbidimeter described in Leighton's paper. By means of an electric flash light, a cross of light is provided at the bottom of a long graduated tube. The well-shaken, turbid water is poured in until the sharp image has disappeared and the hazy cross of light just disappears. This is taken as the end point in the lower part of the tube. In the upper part of the tube (that is, for slightly turbid liquids) there is no hazy cross of light, and the end point

is taken as the depth at which the sharp image of the cross disappears, giving place to a slightly blurred one—that is, it seems out of focus. Table II is provided for converting the turbidimeter depths to parts per million of silica.

TABLE II.—Conversion of turbidimeter readings in depth to parts per million of turbidity.

Reading.	Turbidity (as SiO ₂).	Reading.	Turbidity (as SiO ₂).	Reading.	Turbidity (as SiO ₂).	Reading.	Turbidity (as SiO ₂).
cm.	Parts per million.	cm.	Parts per million.	cm.	Parts per million.	cm.	Parts per million.
2.3	1,000	6.3	350	10.5	210	19.6	110
2.6	900	7.3	300	11.0	200	21.7	100
2.9	800	7.6	290	11.5	190	23.0	90
3.2	700	7.8	280	12.1	180	25.0	80
3.5	650	8.1	270	12.8	170	28.0	70
3.8	600	8.5	260	13.6	160	31.0	60
4.1	550	8.7	250	14.4	150	35.0	50
4.5	500	9.1	240	15.4	140	42.0	40
4.9	450	9.5	230	16.6	130	52.0	30
5.6	400	10.0	220	18.0	120	70.0	20

Turbidity may be also determined with the turbidity rod, which consists merely of a bright platinum wire fastened at right angles to a tape. Under the proper conditions the tape is lowered into the water under examination, and the end point is taken as the depth at which the wire just disappears from view. The tape is calibrated directly to read parts per million of silica (SiO₂).

The disadvantage of the turbidity-rod method is the required nicety of adjustment of conditions, involving the use of a large sample under circumstances often impossible. The turbidimeter method, on the contrary, is independent of most of these conditions. Only a small sample is required. Since the method is based on the diffraction of light, the accuracy of the determination is almost independent of the intensity of the light and, therefore, of the condition of the batteries and bulb. It follows directly that the original calibration as given by Leighton is applicable to any well-constructed turbidimeter. No difficulty was experienced in having a suitable instrument constructed for our purposes.

Sulphates are also determined with the turbidimeter, as described by Leighton. To 100 cubic centimeters of the water is added 1 cubic centimeter of hydrochloric acid (50 per cent concentrated acid by volume) and 1 gram of powdered crystals of solid barium chloride. Precipitations are conveniently made in 250 cubic centimeter glass-stoppered bottles. The water is

allowed to stand for ten minutes, with frequent shakings. The turbidity produced is then determined with the turbidimeter as before. The sulphate content (as parts per million of SO_3) is read from Table III.

TABLE III.—*Converting readings in depths by the turbidimeter into parts per million of sulphate.*

Reading in centimeters.	Parts per million (as SO_3).	Reading in centimeters.	Parts per million (as SO_3).	Reading in centimeters.	Parts per million (as SO_3).
1.0	522	5.4	104	10.8	53
1.1	478	5.5	103	11.0	52
1.2	442	5.6	101	11.2	51
1.3	410	5.7	99	11.4	50
1.4	383	5.8	97	11.6	49
1.5	359	5.9	96	11.8	48
1.6	338	6.0	94	12.0	47
1.7	319	6.1	93	12.4	46
1.8	302	6.2	91	12.6	45
1.9	287	6.3	90	12.8	44
2.0	273	6.4	88	13.0	43
2.1	261	6.5	87	13.5	42
2.2	250	6.6	86	14.0	41
2.3	239	6.7	84	14.5	39
2.4	230	6.8	83	15.0	38
2.5	221	6.9	82	15.5	37
2.6	213	7.0	81	16.0	36
2.7	205	7.1	80	16.5	35
2.8	198	7.2	79	17.0	34
2.9	191	7.3	78	17.5	33
3.0	185	7.4	77	18.0	32
3.1	179	7.5	76	18.5	31
3.2	173	7.6	75	19.0	30
3.3	168	7.7	74	20.0	29
3.4	164	7.8	73	21.0	28
3.5	159	7.9	72	22.0	27
3.6	155	8.0	71	22.5	26
3.7	151	8.1	70	23.0	25
3.8	147	8.2	69	24.0	24
3.9	144	8.3	68	25.0	23
4.0	140	8.5	67	26.5	22
4.1	137	8.6	66	28.0	21
4.2	133	8.7	65	29.0	20
4.3	131	8.8	64	31.0	19
4.4	128	9.0	63	33.0	18
4.5	125	9.1	62	35.0	17
4.6	122	9.3	61	37.5	16
4.7	119	9.5	60	40.0	15
4.8	117	9.7	59	43.0	14
4.9	115	9.8	58	26.5	13
5.0	113	10.0	57	50.0	12
5.1	110	10.2	56	55.5	11
5.2	108	10.4	55	62.0	10
5.3	106	10.6	54	68.0	9

Calcium was formerly determined turbidimetrically by the United States Geological Survey method, but this has been abandoned because of its inaccuracy.

The qualitative field test for calcium is made by adding enough ammonia to some of the water in a test tube or bottle to make it alkaline to litmus and adding some ammonium oxalate.

Total solids are determined qualitatively by evaporating 50 cubic centimeters of the water in a porcelain casserole to dryness over an alcohol lamp. The solid content is reported merely as "very small," "moderate," "large," etc. The residue is then ignited, and any change in "appearance on ignition" is noted. This may be a browning or blackening due to organic matter, or a deep red-brown coloration due to the oxidation of considerable amounts of iron present. The last is of value as a confirmatory test for large amounts of iron.

Odor is reported, wherever possible, in such a way that both the derivation and the relative amount are indicated, for instance, "very slightly sulphuretted," "strongly acid."

Alkalinity, acidity, chlorides, normal carbonates, and total hardness are determined by the use of tablets, as outlined by Leighton. In brief, this method consists of the use of pellets containing known amounts of reagents, instead of standard solutions. The titrations are performed in a small (100 to 150 cubic centimeters), heavily glazed porcelain mortar, a pestle being used to crush the pellets and to stir the liquid. The volume of water used for a titration is conveniently measured from a tall, 100 cubic centimeter graduated cylinder, provided with a double scale, so that both the water withdrawn and the volume remaining can be directly read. What are practically duplicate determinations can be made very rapidly in the following manner:

A few pellets are crushed in the mortar, and water is added from the cylinder till the end point is reached. The volume used is noted. Several more pellets—preferably the same number as before—are added, followed by water from the cylinder, until the second end point is obtained. In this way not only is it possible to secure more accurate results by taking the mean of the two values obtained than by making a single determination, but in addition any gross error that may arise from an unclean mortar, contaminated indicator, or defective tablet can be detected and corrected.

The following reagents are used in tablets in the various determinations:

Sodium acid sulphate for alkalinity and normal carbonates;

sodium carbonate for acidity; silver nitrate for chlorides; and potassium palmitate for total hardness.

Kaolin is used as the filter and binding material for the sodium carbonate and silver nitrate pellets, while glucose is employed for those of sodium acid sulphate and potassium palmitate. Glucose is superior to kaolin, as it is completely soluble and consequently does not obscure the end point. It cannot, however, be used in the first two cases, because unstable pellets result. Water is used in all cases in making up the pill mass. The reagent is dissolved in water and carefully stirred into the binding material. The mass is kneaded in a mortar, more water being added if necessary, until it is homogeneous and of the desired consistency.

The tablets are made in a tablet mold. We use a hard rubber mold (No. 10, Whitall Tatum Company, for making 50 one-grain tablets at a time). The molded pellets are dusted with powdered talc, dried in the air and then in a desiccator over calcium chloride, after which they are packed in glass tubes, about 15 centimeters in length and holding about forty pellets each. The tubes are sealed with paraffin, and those containing pellets of silver nitrate are covered with heavy black paper. Needless to say, the silver nitrate pellets are made in a dark room.

The silver nitrate and sodium carbonate pellets retain their strength almost indefinitely without change. Those of sodium acid sulphate lose strength very slowly and should be restandardized every month. The potassium palmitate pellets lose strength rather rapidly and should be restandardized weekly.

Alkalinity.—Pellets are molded from a pill mass containing 6.5 grams of crystallized sodium bisulphate and 150 grams of glucose, the proportions that will yield a pill of very nearly the desired strength (one pellet equivalent to 1 milligram calcium carbonate, CaCO_3). The pellets are standardized by crushing five of them in a mortar with a little distilled water and adding a drop of butter yellow indicator solution (0.2 gram butter yellow in 100 cubic centimeters of alcohol). Tenth-normal sodium hydroxide or sodium carbonate is added till the end point is reached. From this titration the reacting value of the pellets may be readily calculated.

The field determination of alkalinity is analogous to the standardization of the pellets. The 100 cubic centimeter cylinder is filled to the mark with the water under examination. Two or three of the pellets are crushed in the mortar with a little of the water, and a drop of the indicator is added, followed by more water from the cylinder till the end point is reached.

The volume of water used in the titration is noted, readings being taken to the tenth of a cubic centimeter. Two or three more pellets are added, followed by more of the water to the second end point.

The alkalinity, expressed as parts per million CaCO_3 , is readily calculated from the number and strength of pellets and the volume of water used in the determination. Thus, if 4 pellets of sodium bisulphate, each equivalent to 1.10 milligrams of calcium carbonate, require 22.4 cubic centimeters of the water for interaction, the alkalinity will be

$$\frac{1,000 \times 4 \times 1.10}{22.4} = 196$$

and would be reported as 200 (that is, in terms of two significant figures).

Normal carbonates.—If normal carbonates (or hydroxides) are present, the water will give a pink coloration with phenolphthalein. In this event the amount of normal carbonates is determined with pellets of sodium bisulphate. The procedure is identical with that for the determination of alkalinity, except that 5 drops of phenolphthalein indicator solution (1 per cent alcoholic) are used instead of the 1 drop of butter yellow. Where the normal carbonates are present only in small amount, half, or even a quarter, of a pellet may be all that can be used.

As phenolphthalein is sensitive to carbonic acid, the end point in this determination is reached when only half of the alkali is neutralized. Accordingly the same sodium bisulphate pellet that was equivalent to 1.10 milligrams of calcium carbonate in the determination of alkalinity will be equivalent to twice that amount, or 2.20 milligrams, when used in the determination of normal carbonates.

Thus, if 2 of these pellets required 57 cubic centimeters of the water for the reaction, the results expressed in parts per million of calcium carbonate would be

$$\frac{1,000 \times 2 \times 2.20}{57} = 77.$$

When, as is usually the case with Philippine waters, the phenolphthalein alkalinity is less than half that determined with butter yellow, the alkalinity of a natural water is caused by bicarbonates and normal carbonates and is equal to their sum. If, therefore, no normal carbonate is present, the alkalinity is numerically equal to the bicarbonates, when both are expressed in terms of calcium carbonate. If, when normal carbonates are present, the alkalinity is found to be equal to the normal carbonates—that is, when the phenolphthalein titration is one

half that with butter yellow—the absence of bicarbonates is indicated. If the alkalinity is found greater than the normal carbonates, the difference will be bicarbonates, all expressed as calcium carbonate.

If, however, the phenolphthalein titration is more than one half that with butter yellow, the waters contain calcium or other alkaline hydrates (caustic alkalinity). In case the phenolphthalein and butter yellow titrations are identical, all of the alkalinity is due to hydrates.

The relations between the various forms of alkalinity just discussed are shown in Table IV.⁴

TABLE IV.—*Relation between normal carbonates, bicarbonates, and hydrates in natural waters, as indicated by titration with sulphuric acid (sodium bisulphate) in cold.*

	Carbon-ates.	Bicar-bonates.	Hydrates.
P=O.....	O	B	O
P< $\frac{1}{2}$ B.....	2P	B-2P	O
P= $\frac{1}{2}$ B.....	2P	O	O
P> $\frac{1}{2}$ B.....	2(B-P)	O	2P-B
P=B.....	O	O	B

P, phenolphthalein titration; B, butter-yellow titration.

When it is desired to express normal carbonates as sodium carbonate, the calcium carbonate value is multiplied by 1.06. Similarly the bicarbonates may be expressed as HCO_3 by multiplying the calcium carbonate equivalent by 1.22.

Acidity.—If a water reacts acid to phenolphthalein, the presence of carbonic or a mineral acid is indicated. In the first case bicarbonates may be present, but normal carbonates will not. In the second case neither bicarbonates nor normal carbonates can be present, and the water will react acid to butter yellow or methyl orange as well as to phenolphthalein.

Mineral acidity, when present, is determined with pellets of sodium carbonate, using butter yellow as an indicator. Total acidity, due to the combined effect of mineral and carbonic acids, is also determined with pellets of sodium carbonate, but in the presence of phenolphthalein as indicator. The carbonic acid acidity is the difference between the total and the mineral acidities.

Mineral acidity in natural waters is rarely encountered in the Philippines. Acidity is practically always due to free carbon di-

⁴ Cf. Standard Methods of Water Analysis, American Public Health Association, Boston. 2d ed. (1915), 39.

oxide and is, therefore, determined with sodium carbonate pellets, using 5 to 10 drops of phenolphthalein solution as indicator. The manipulation is identical with that described for "alkalinity" and "normal carbonates," except that, ordinarily, only one or two tablets, or even less, will be required for a titration. Furthermore, since the kaolin in the pellets slightly obscures the end point, the discrepancy between duplicate determinations is usually 0.5 cubic centimeter and often 1 cubic centimeter.

In the manufacture of the sodium carbonate pellets 4.0 grams of anhydrous sodium carbonate are used to 130 grams of kaolin. This gives a pellet of approximately the desired reacting value, namely, 1 milligram of carbon dioxide. To standardize, 5 of these pellets are triturated in a mortar with recently boiled distilled water, 5 drops of phenolphthalein solution are added, and the solution is titrated with 0.1 *N* sulphuric acid.

If, in a field determination, it is found that the average of two readings taken for the reaction with 1 pellet equivalent to 0.95 milligram of carbon dioxide (phenolphthalein being used as indicator) is 24 cubic centimeters of the water, the acidity, expressed in parts per million of carbon dioxide, would equal

$$\frac{1,000 \times 0.95}{24} = 40.$$

Chlorides.—For the determination of chlorides, "weak" and "strong" pellets of silver nitrate are employed. The former are each equivalent to about 1 milligram of chlorine, the latter to 10 milligrams. In the manufacture of the weak pellets, 12.5 grams of silver nitrate and 200 grams of kaolin are used, while 156 grams of silver nitrate and 250 grams of kaolin are the proportions used for the strong pellets.

The pellets are standardized with a sodium chloride solution, which is conveniently made to be equivalent to 1 milligram of chlorine per cubic centimeter. Potassium chromate is used as an indicator.

The determination of chlorides in the field is rapid and simple. A small quantity of water, usually only 10 or 15 cubic centimeters, is introduced from the filled 100 cubic centimeter graduate into the mortar. Five drops of potassium chromate solution (5 per cent) are added as indicator. If the chlorine content of the water is high, "strong" silver nitrate pellets are added one at a time, with thorough mixing, until an excess is indicated by the rose color of silver chromate. If the chlorine content is low, "weak" pellets are added till the end point is passed. If the chlorine content is low, that is, under 10 parts per million, a half or even quarter tablet will be sufficient. In any

case, after an excess of silver nitrate has been provided, more water is added from the cylinder until the rose color is entirely displaced by a bright yellow, corresponding to the shade used in standardization. Check determinations may be made as before by adding more pellets and titrating.

If, to react with a half of a "weak" tablet (a whole tablet being equivalent to 0.96 milligram of chlorine), there were required 76 cubic centimeters of the water under examination, the chlorine content, expressed in parts per million of chlorine, would be found from the expression

$$\text{Cl} = \frac{1,000 \times 0.5 \times 0.96}{76} = 6.3.$$

Total hardness.—The pellets of potassium palmitate used for the determination of hardness are made from a pill mass of glucose and potassium palmitate. One hundred grams of glucose are used with an amount of potassium palmitate corresponding to 15 grams of palmitic acid. To make potassium palmitate, palmitic acid is dissolved in alcohol and neutralized with normal alcoholic potash solution, using phenolphthalein as indicator. The resulting alcoholic solution is then evaporated to dryness. The residue may be used without further treatment for making the pellets.

The following method is employed for the standardization of the pellets: A saturated solution of calcium hydroxide is prepared from pure calcium oxide. The normality of this is determined by titration of 25 cubic centimeters with 0.1 *N* sulphuric acid, using phenolphthalein as an indicator. One hundred cubic centimeters of the calcium hydroxide solution are then pipetted into a 200 cubic centimeter volumetric flask. A few drops of phenolphthalein solution are added, followed by normal sulphuric acid to acid reaction. Alcoholic potash (0.2 *N*) is then added, drop by drop, until a faint pink is produced. Distilled water that has previously been boiled to expel carbon dioxide is added to the mark.

The calcium sulphate solution thus prepared is used to standardize the pellets. Five of these, crushed in a mortar with a little distilled water, and 5 drops of phenolphthalein are added. The standard calcium sulphate solution is then added from a burette, until the last trace of phenolphthalein pink disappears. From the number of cubic centimeters used, and the determined strength of the calcium hydroxide solution, the strength of the pellets, expressed in term of calcium carbonate, is calculated.

Since a saturated solution of calcium hydroxide is about 0.04

N, the standard calcium sulphate solution as prepared above will be about 0.02 *N*, that is, 1 cubic centimeter will be equivalent to about 1 milligram of calcium carbonate.

The potassium palmitate tablets, as prepared above, will each be found equivalent to 1.5 to 2.0 milligrams of calcium carbonate.

These pellets should be standardized every week, as they lose strength fairly rapidly. What this loss of strength is due to is not yet certain, but from the data at hand it seems at least possible that it may arise from an acid fermentation of the glucose, bringing about a decomposition of the potassium palmitate with the separation of palmitic acid.

For use in the determination of total hardness, 1 cubic centimeter graduation marks were etched on a 100 cubic centimeter cylinder, so that volumes up to 105 cubic centimeters could be read. For a determination, 100 cubic centimeters of the water, measured in this cylinder, are transferred to a dry 250 cubic centimeter bottle (the glass-stoppered variety is convenient). A very small piece of methyl orange paper is suspended in the liquid by means of a platinum wire, while normal sulphuric acid is added from a dropping bottle until the paper becomes red. The paper is then removed to avoid coloring the liquid.

The liquid is then aspirated for five minutes with a continuous pressure bulb operated by hand. After aspiration, 1 cubic centimeter of phenolphthalein is added, followed by 0.2 *N* alcoholic caustic potash from a pipette, till a faint pink coloration develops. The liquid is now returned to the cylinder, the bottle being drained as completely as possible. The volume of the liquid is noted within 0.5 cubic centimeter. This will usually be between 102 and 105 cubic centimeters.

About 10 cubic centimeters of the liquid are then introduced into the mortar. One or more potassium palmitate pellets are then added, until an excess is present, that is, when a pronounced phenolphthalein coloration is produced. More water is then added from the cylinder, until the phenolphthalein coloration completely disappears. The volume of water used is noted. Several more pellets are then added, followed by water, till a second end point is reached. The two determinations should check each other within 0.5 to 1 cubic centimeter.

It is well to use four or five pellets in the two titrations to avoid any considerable error due to the lack of uniformity in the pellets.

To calculate the total hardness, it is first necessary to reduce the number of cubic centimeters of the water as used in the determination to the equivalent number of cubic centimeters of

the original water, that is, before it was diluted with sulphuric acid, phenolphthalein, and alcoholic potash. Then the total hardness is computed from the value and number of the pellets used.

For example, let us suppose that the original volume of 100 cubic centimeters had been diluted to 104.5 cubic centimeters before titration with the palmitate pellets, each equivalent to 1.80 milligrams of calcium carbonate. Obviously the 48.5 cubic centimeters used for the determination are equal to

$$\frac{48.5 \times 100}{104.5} = 46.4$$

cubic centimeters of the original water.

Therefore the total hardness would be derived from the expression

$$\frac{1,000 \times 4 \times 1.80}{46.4}$$

Or, using the data above, we may represent the entire calculation in one line as follows: Total hardness (as parts per million calcium carbonate) is equal to

$$\frac{10 \times 104.5 \times 4 \times 1.80}{48.5} = 155.$$

Total solids may be also estimated with the aid of Dole's formula,⁵ slightly modified. For Philippine ground waters the following will be found satisfactory:

100 + normal carbonates (as Na_2CO_3) + bicarbonates (as CaCO_3) + 1.7 SO_4 + 1.6 Cl.

Estimated encrustants are calculated (for clear water) from Dole's formula:⁶

$$\text{Estimated encrustants} = \frac{\text{Bicarbonate alkalinity (as CaCO}_3\text{)} + \text{CaSO}_4 + \text{total hardness (as CaCO}_3\text{)}}{2}$$

Assuming the sulphates to be present as calcium sulphate, the CaSO_4 in the above formula may be calculated as 1.7 SO_4 . In this form the formula is available for field work.

Classification for boiler use is based upon the amount of estimated encrustants, as given by the American Railway Engineers' Maintenance of Way Association:⁷

⁵ Dole, R. B., *U. S. Geol. Surv., Water Supply Paper* (1916), No. 399, 304.

⁶ *U. S. Geol. Surv., Water Supply Paper* (1910), No. 254, 232.

⁷ *Proc. Am. Ry. Eng. & Maint. Way Assoc.* (1904), 5, 595.

TABLE V.—Classification for boiler use.

Parts per million.	
Less than 90	Good.
90 to 200	Fair.
200 to 430	Poor.
430 to 680	Bad.
Over 680	Very bad.

The use of the Berkefeld army filter to clarify turbid waters, as suggested by Leighton, has been discontinued in our field work for several reasons. Comparatively few of the waters examined on the average field trip are turbid. An analysis of only the clear portion of a turbid water is ordinarily not of great value, and when it is desired, a clear sample is readily obtained by sedimentation or by filtration through cotton or paper. Turbidity interferes appreciably only with the determination of sulphates. Its effect can be readily overcome by determining the turbidity of the liquid after adding hydrochloric acid and before adding barium chloride and subtracting this from the reading obtained after the sulphates have been precipitated. The difference represents the sulphate turbidity, and the amount of sulphates can be determined from the table without appreciable error. In short, the Berkefeld filter has found such limited application in our work that the minor benefits derived from its use have not been commensurate with the trouble and inconvenience of carrying it.

Accuracy of field determinations.—While field methods do not claim the exactness and accuracy possible in the laboratory, it is interesting to note that in several cases the values obtained by the two procedures do not differ very widely. As has been previously stated, results obtained in laboratory determinations are expressed in terms of two significant figures only. This mode of expression itself involves limits of accuracy that permit a maximum error of about 4 per cent. The average accuracy of field determinations, as stated by Leighton and confirmed in our own work, is roughly about 5 per cent. Turbidity shows the widest variation, ranging from about 3 per cent with turbidities of 500 to 1,000 parts per million to about 16 per cent with a turbidity of 30 parts per million, the deviation increasing fairly regularly with decreasing turbidities.

There are several sources of probable error of which the following are the most important:

When using a 100 cubic centimeter graduated cylinder, volumes cannot be read more accurately than to the nearest tenth of a cubic centimeter and often not that accurately. Further,

when the mortar is washed with the water under examination, a certain amount remains in the mortar, which affects the volume subsequently employed for the next titration. Also the lack of uniformity in the pellets may introduce a very appreciable error.

In our own work additional sources of probable error have been encountered with "tabloid" methods. Our pellets are molded by hand and are, consequently, not as uniform as machine-made pellets. This is especially true of the potassium palmitate pellets, which form a sticky pill mass that dries very quickly and that is very difficult to mold uniformly. Again kaolin is used in the sodium carbonate and silver nitrate pellets and obscures the end points, thus decreasing the accuracy of the determinations.

In the "tabloid" determinations outlined above our methods differ from Leighton's in that, in the determination of chlorides and of total alkalinity, Leighton treated a known quantity of water with an excess of reagent to obtain an end point, while in all cases we titrate a known amount of reagent with the water to secure an end point. The former method gives values that lie between certain limits, as the excess of reagent is added in the form of parts of a pellet, and consequently the exact amount of reagent required for the titration is not determined. By making the excess small, the deviation from the true value is correspondingly decreased.

By our method, however, the exact titrating volume required is determined quickly and fairly accurately. The approach to the end point is thus reversed. This probably introduces an error in the determination of chlorides, which, however, is certainly much less than that involved in Leighton's method. It should be also remembered that the standardization of the pellets is made in the same manner as the field determination, thus decreasing the probable error. In the case of the determination of alkalinity, however, where methyl orange or butter yellow is employed as indicator, the reversed approach to the end point (that is, from acid to alkali) is theoretically the more correct of the two procedures and should, therefore, further increase the accuracy of the method as outlined above.

BACTERIOLOGICAL EXAMINATION

The bacteriological examination consists of two parts. One of these is a colony count made from two plate cultures. The other is a presumptive test for the presence of organisms of the *B. coli* group, which is made with one or more culture tubes.

The culture medium used in both cases is litmus lactose agar

(1.5 to 2.0 per cent agar, 1 per cent lactose). The reaction of this medium is almost neutral, there being present barely enough alkalinity to give a slight blue. It is put up in test tubes, in 10 cubic centimeter portions, and is thoroughly sterilized.

The Petri dishes used for the plate cultures are packed in individual envelopes and then sterilized. The envelopes, made of heavy Manila paper, are about the same width as the dishes and about twice as long as they are wide. Packages of six plates, well wrapped with paper, may be transported with little danger of breakage and will remain sterile indefinitely.

The pipettes used hold 1 cubic centimeter and are about 20 centimeters long. If these are not available, they may be readily made from glass tubing. The pipettes in lots of six are well wrapped in cheesecloth, having several folds of cloth between one pipette and the next. The ends of the package are tied together, and the package is inserted in a tin can just large enough for the purpose. The closed tin can containing the pipettes is then sterilized. While warm, the can is sealed with adhesive tape. When cool, the tape is well covered with paraffin. Pipettes so packed will remain sterile almost indefinitely.

For several kinds of work sterile bottles may be employed. Instead of the ordinary cotton plugs, which are often either pushed in or which come out during transportation, we use a cotton-covered cork. This arrangement has been found very satisfactory.

Ordinarily two plate cultures and one tube culture are made of each sample. Three tubes of media are thus required. The tubes are melted by heating in water over an alcohol lamp and are then cooled to 45°.

Plating is done at a temperature of from 40° to 43° C. For a water such as that from a spring or artesian well, believed to be comparatively pure, 0.5 and 1.0 cubic centimeter cultures are made. For a water suspected of contamination, plates may be made of 0.2, 0.1, or 0.05 cubic centimeter, depending on the apparent degree of contamination. The water is introduced into the Petri dish, the liquified agar is added, and the plate is manipulated to insure thorough mixing. After complete cooling, the plates are returned to their envelopes and carried in an inverted position to prevent spreading of the colonies by water of condensation.

The tube culture for the presumptive test is made by introducing the desired amount of water into the tube of liquified agar and mixing thoroughly by agitation. Usually 1 cubic centimeter is taken for this test, though more or less may be em-

ployed. The upper limit will be determined by the fact that 1 per cent agar is the weakest that solidifies on cooling to the temperatures ordinarily encountered (25° to 30° C.).

Incubation is at the ordinary temperature. No special apparatus is, therefore, required.

Colony counts are made both at the end of twenty-four and forty-eight hours, using a lens magnifying at least 5 diameters. The average of the two counts is the recorded value.

When the number of colonies is high, the plate is marked into sectors of convenient size, and the total number of colonies is estimated, or else the number on representative areas of 1 square centimeter is determined (a small card with openings of appropriate size and shape has been found very convenient for field work), and the necessary calculation for the total area is made. The presence of red colonies is noted.

The presence of the organisms of the colon group is indicated by the formation of gas in the tube cultures and by the formation of acid, as shown by the change of litmus from blue to red.

Summing up the whole question of the value of field methods, it might not be out of place to quote from the introduction of Leighton's paper:

To the methods hereinafter proposed the term "assay" readily lends itself. There is no attempt at water analysis. The plan contemplates the determination of ingredients which give to water certain well-known characteristics. The methods have been found to be more nearly accurate than was at first anticipated, though this fact, it is believed, has not greatly increased their usefulness for the purposes in view. By their use, combined with a fair amount of common sense, the essential characteristics of waters can be ascertained at small expense. In almost every situation in which such determinations are significant they will afford sufficiently satisfactory data. In the case of finely balanced considerations of a purely physical, chemical, or geologic nature, however, they are practically useless. They are intended for practical purposes and have no place in pure science.

In the Philippines field methods have shown themselves to be both accurate and efficient. They have enabled the differentiation between good and bad waters used for domestic purposes, the selection of proper water for municipal supplies, the condemnation of dangerous sources of infection in cholera-infested districts, and the rapid evaluation of waters desired for industrial purposes.



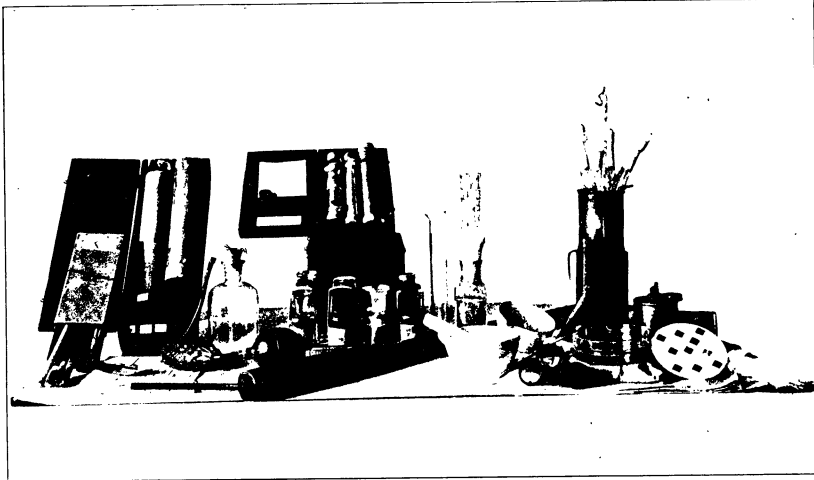

Fig. 1. Apparatus used in a field assay of water.

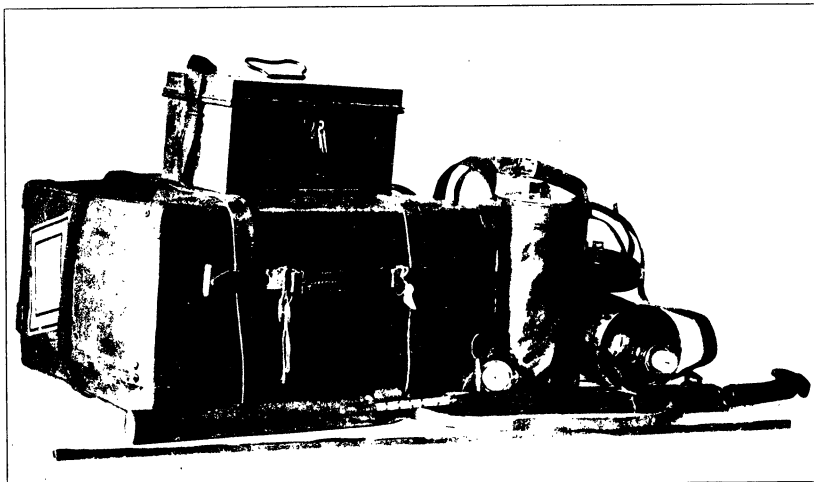

Fig. 2. The same, packed for transportation.

PLATE I.



ILLUSTRATION

PLATE I

- FIG. 1. Apparatus used in a field assay of water.
2. The same, packed for transportation.

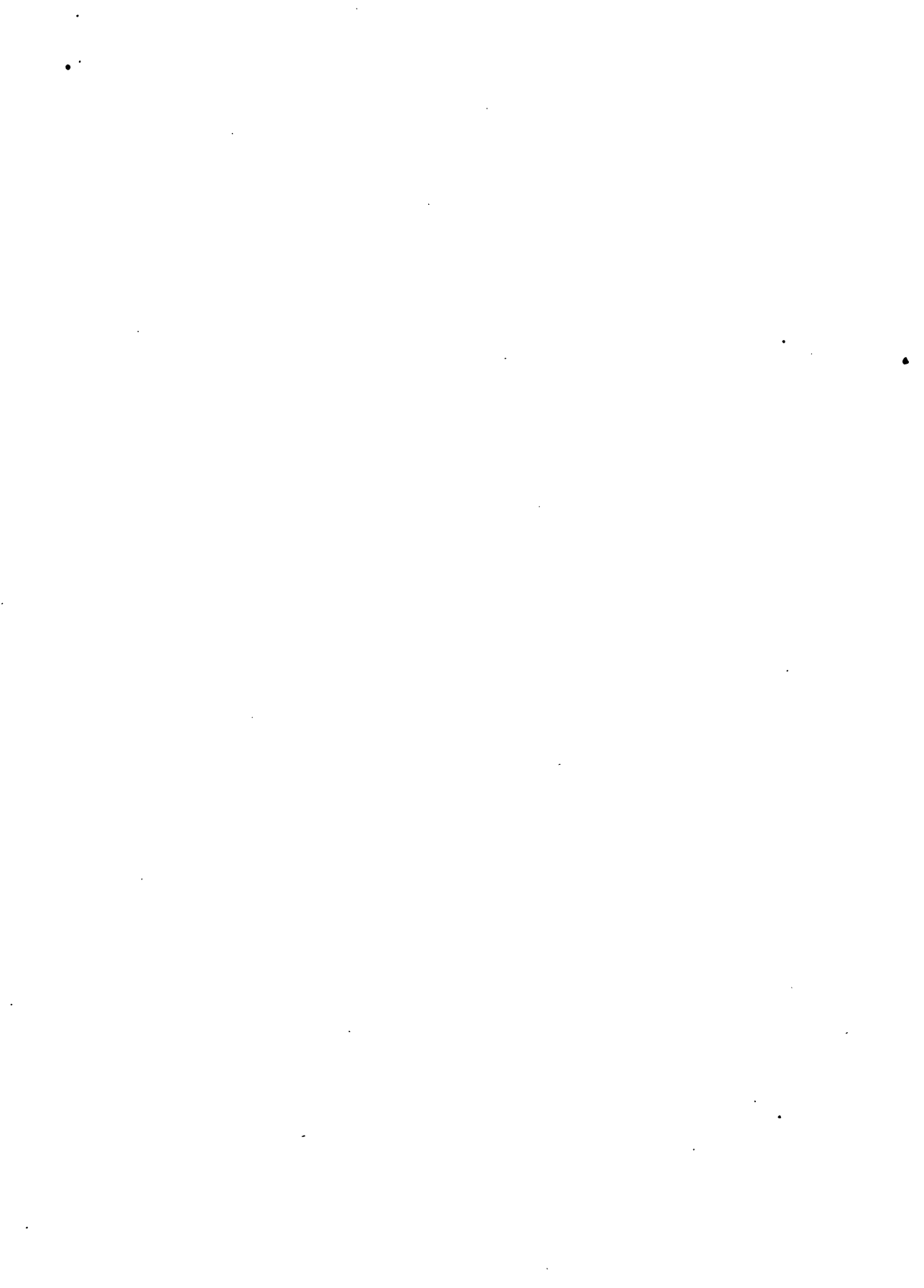

TWO FIELD METHODS FOR THE DETERMINATION OF THE TOTAL HARDNESS OF WATER ¹

By A. S. BEHRMAN

(From the Laboratory of General, Inorganic, and Physical Chemistry,
Bureau of Science, Manila)

In a field examination of the chemical quality of water the determination of total hardness is one of the most important analytical procedures. The data thus obtained, when used in conjunction with the results of the other commonly made determinations, give definite and quantitative information as to the nature of the most important of the dissolved constituents. This knowledge may be employed to advantage in connection with various problems related to water supplies, such as potability, purification, and industrial applications.

The Blacher method ² for the determination of the total hardness of water by titration with potassium palmitate has been found to possess several marked advantages over the standard soap solution and similar procedures. It is clear-cut, accurate, and rapid.

Based on a study ³ of this method as applied to the analysis of typical Philippine waters, two field methods for the determination of hardness have been devised. Both are "tabloid" in nature, employing pellets of potassium palmitate instead of a solution of the reagent.

METHOD I

The first of these procedures is similar to Leighton's field modification ⁴ of the soap-solution method, in that the reagent is added in tablets of three strengths, until a sufficient excess is present to give a characteristic end reaction. Pellets of the same reacting values as those suggested by Leighton for sodium oleate are used, namely, 2.0, 1.0, and 0.5 milligrams of calcium carbonate, respectively.

One hundred cubic centimeters of the sample are measured into a 250 cubic centimeter bottle. A small piece of methyl

¹ Received for publication September 11, 1917.

² Blacher, C., Grünberg, P., and Kissa, M., *Chem. Zeitg.* (1913), 37, 56-8.

³ Behrman, A. S., *This Journal, Sec. A* (1916), 11, 291.

⁴ Leighton, M. O., *U. S. Geol. Surv., Water Supply Paper* (1905), No. 151.

orange (or butter yellow) paper is suspended in the liquid by a hooked platinum wire, and normal sulphuric acid is added from a dropping bottle, until the indicator gives a decided acid reaction.⁵ The paper is then removed from the bottle, to avoid absorption of the indicator. The solution is next strongly aspirated for five minutes, to remove carbon dioxide, using a continuous pressure atomizer bulb. When the aspiration has been effected, 1 cubic centimeter of phenolphthalein indicator solution (1 per cent) is added to the liquid by means of a 1 cubic centimeter bulb pipette. The acidity of the solution is neutralized with 0.2 *N* alcoholic potash, which is added drop by drop until a barely perceptible pink is observed.

The solution is now ready for treatment with the pellets of potassium palmitate. These are added in the same manner as in Leighton's method, using first the strong tablets and later the weaker ones, until an excess is present. The end point in this case is a deep phenolphthalein coloration.

A short cut that may be used advantageously in this method is to pour half of the solution to be treated with the pellets into another receptacle. Strong pellets are added rapidly to the portion in the bottle, until an excess has been provided. The remainder of the liquid is then returned to the bottle, after which the end point may be approached quickly, using the information gained in the treatment of the first portion.⁶

METHOD II

The second procedure differs from the first in that the end point is reached when an excess of the water, instead of potassium palmitate, is present. In addition, pellets of only one strength are employed, "whole" tablets being advantageously used.

A 100 cubic centimeter portion of the sample is acidified,

⁵ The addition of acid would, of course, be unnecessary in the case of a water with an acidity due to mineral acids. Such waters are extremely rare in the Philippines.

⁶ From the number and strength of pellets used, the hardness of the water is readily calculated. Thus, if there were required 7 "whole," 3 "half," and 2 "quarter" tablets, having reacting values of 2.0, 1.0, and 0.5 milligrams of calcium carbonate, respectively, the total hardness, expressed in terms of parts per million of calcium carbonate, would be derived from the following expression:

$$\text{Total hardness} = \frac{1,000 \times [(7 \times 2.0) + (3 \times 1.0) + (2 \times 0.5)]}{100} = 180.$$

aspirated, and neutralized, exactly as in the first method. The liquid, thus prepared, is returned to the 100 cubic centimeter cylinder, and the volume is noted with the aid of graduation marks, etched on the cylinder at 1 cubic centimeter intervals to 105 cubic centimeters. The volume of the liquid should be read to the nearest 0.5 cubic centimeter. This will be usually found to be between 102 and 105 cubic centimeters.

In a small (100 cubic centimeter), heavily glazed porcelain mortar two or three pellets of potassium palmitate are crushed with 10 or 15 cubic centimeters of water from the cylinder. If an excess of the reagent is not indicated by the characteristic phenolphthalein coloration, more pellets are added until this condition is reached. More water is then added from the cylinder, slowly and with constant stirring, until the phenolphthalein coloration completely disappears, giving place to a creamy or yellowish white (depending on the amount of methyl orange absorbed during acidification). The end point is sharp and is easily determined. The volume required for the first end point is noted, reading to the nearest 0.5 cubic centimeter. Several more pellets are then added, preferably using the same number as before. Water is again supplied from the cylinder, until a second end point is obtained, and the amount used is noted. The two volumes should check within 0.5 cubic centimeter in fairly hard waters. Where a slightly larger difference is found, the mean of the two determinations may be employed in calculating the total hardness.⁷

PREPARATION AND STANDARDIZATION OF POTASSIUM PALMITATE TABLETS

Potassium palmitate being unavailable, it was prepared by the neutralization of an alcoholic solution of purified palmitic

⁷The volume used in the determination is reduced to the volume of the original water, that is, before being diluted with acid, indicator, and alkali. The total hardness is then calculated from this corrected volume of water and from the number and strength of potassium palmitate tablets employed in the determination. Thus, if a 100 cubic centimeter portion of a given water was diluted to 103.5 cubic centimeters before treatment with potassium palmitate, and if, of this diluted volume, 42.5 cubic centimeters were required to react with 4 pellets of potassium palmitate, each equivalent to 2.0 milligrams of calcium carbonate, the total hardness, expressed as parts per million of calcium carbonate, would be found from the following expression:

$$\text{Total hardness} = \frac{10 \times 103.5 \times 4 \times 2.0}{42.5} = 195.$$

acid with a normal solution of alcohol potash. The resulting liquid was evaporated to dryness.

For the "whole" tablets 100 grams of finely powdered glucose are used with the potassium palmitate from 15 grams of palmitic acid. Corresponding amounts are employed for the weaker pellets. With the aid of a little distilled water, a homogeneous pill mass is made and is promptly molded to avoid changes in consistency. Where molding must be done by hand, a Whithall Tatum Company No. 2 tablet mold, which makes fifty pellets at one time, has been found satisfactory.

After being molded, the pellets are dusted with powdered talc; they are then dried, first in the air and then in a desiccator. They are subsequently packed in glass tubes, which hold about forty pellets and which are sealed with paraffin until desired for use.

The potassium palmitate pellets are standardized with a solution of calcium sulphate, prepared as follows from a saturated solution of calcium hydroxide: The normality of the calcium hydroxide is determined by titration with standard 0.1 *N* sulphuric acid. Into a 200 cubic centimeter volumetric flask are pipetted 100 cubic centimeters of the calcium hydroxide solution, and 1 cubic centimeter of phenolphthalein indicator solution is added. The solution is acidified with normal sulphuric acid and is then neutralized with 0.2 *N* alcoholic potash. Only a very faint phenolphthalein coloration should be present. Recently boiled, distilled water is now added to the mark.

Five of the pellets to be standardized are crushed in a mortar with a little distilled water, and phenolphthalein is added. This solution is titrated with the calcium sulphate, prepared as above, which is added drop by drop from a burette, with constant stirring. The end point is the disappearance of the phenolphthalein coloration,⁸ just as in the field determination. From the mean of several such standardizations is calculated the reacting value of the pellets.

Unfortunately pellets of potassium palmitate lose their strength rather rapidly and must, therefore, be restandardized at frequent intervals. The exact cause of this deterioration is not as yet definitely known, but from the data at hand, it appears at

⁸It is essential, in preparing from palmitic acid the potassium palmitate to be used for pellets, that neutralization be effected with the slightest possible excess of alkali. If any appreciable amount of free alkali is present, the alkaline reaction to phenolphthalein will be due to this cause as well as to hydrolysis of the potassium palmitate and will not, therefore, disappear when an excess of calcium or magnesium salts is present.

least possible that the reason may be found in an acid fermentation of the glucose, in which a portion of the potassium palmitate is decomposed, with the separation of free palmitic acid.

It is possible that this objection may be overcome by the choice of a material more suitable than glucose. However, using the pellets made with glucose, it has been found very satisfactory to standardize the tablets weekly in the central laboratory in Manila and to supply the worker in the field with these data. A typical series of such standardizations is given in Table I.

TABLE I.—*Reacting values of "whole" potassium palmitate pellets. (Milligrams of calcium carbonate per pellet.)*

Date.	Reacting value.
April 4	1.68
April 12	1.59
April 27	1.52
April 30	1.49
May 7	1.43
May 14	1.33
May 21	1.22
May 28	1.06
June 5	0.89

The figures in Table I indicate a gradual and fairly uniform loss of strength in the pellets. In field investigations extending over comparatively short periods of time, reacting values may be obtained without serious error by interpolation. Where an extensive field study is planned, however, the method of periodic standardization in a central laboratory is preferable.

ACCURACY OF RESULTS AND COMPARISON OF METHODS

The first method described is essentially a field modification of Blacher's laboratory procedure and, therefore, has as its maximum accuracy that of the latter manipulation. From this must be subtracted the errors accruing from the field technic. Here the possible sources of error are the presence of a relatively large amount of glucose, the lack of uniformity of the pellets, the inaccuracy in reading volumes, and the fact that an excess of reagent is employed to obtain the end point.

The accuracy of the Blacher laboratory method has been found by a number of workers⁹ to be about 2 to 3 per cent. That glucose does not introduce an error, in the quantities used, was

⁹ Zink, J., and Hollandt, F., *Zeitschr. f. angew. Chem.* (1914), 27, 439. Nochmann, E., *Pharm. Zentralh.* (1914), 55, 436-7. Behrman, A. S., loc. cit.

shown in a series of experiments in which concentrations as high as 2 per cent of glucose—a condition not met with in practice—were employed without appreciably affecting the end point. Since volumes may be read to 0.1 cubic centimeter with a tall 100 cubic centimeter cylinder, the error involved here is also negligible. The error due to the excess of reagent present when an end point is obtained may be reduced to 1 or 2 per cent by making the excess small. The error due to lack of uniformity in the pellets may be placed at a like figure.

It is, therefore, reasonable to assume an error of about 5 per cent in using this method, an estimate that was verified in the case of several natural and artificially prepared waters. This degree of accuracy is ordinarily sufficient in questions of potability or of the suitability of a water for technical purposes.

No extensive comparison was made of results obtained from this method and those from gravimetric determinations. This was due to the fact that the first method was discontinued in favor of the second, as soon as the latter had been shown to be sufficiently accurate for field work.

The second procedure possesses three important advantages over the first:

(1) It is more rapid. The solution of the pellets in the first method requires considerable time. It was found that from fifteen to twenty minutes were required for a determination by the first method, while ten to twelve minutes sufficed for the second. (The five minutes employed in aspiration in both methods may be usually subtracted from the time of the analyst required, as this may be performed by an unskilled attendant.)

(2) Less reagent is needed. As only a part of the sample taken is treated with potassium palmitate, the second method will ordinarily require only a third or a fourth of the number of pellets required in the first.

(3) Several determinations may be rapidly made from the same sample, thus avoiding any gross error that may occur in a single determination.

The error of the second method is, like that of the first, about 5 per cent. It is believed that the accuracy of the method could be increased by machine-molding the pellets, thus securing greater uniformity, and by the selection of a material more suitable for binding and filling than glucose.

In Table II are shown the results of a number of field determinations of total hardness by the second method, compared with the calculated values of the same from gravimetric analyses of the calcium and magnesium contents.

TABLE II.—*Comparison of field and gravimetric determinations of total hardness.^a*

No.	Calcium.	Magne- sium.	Total hardness (calcu- lated).	Total hardness (field method).	Error (per cent).
1	140	11	395	385	2.5
2	36	14	150	165	10.0
3	94	21	320	340	6.3
4	80	24	300	285	5.0
5	34	25	185	195	5.4
6	12	3.8	46	49	6.5
7	92	28	345	350	1.5
8	81	23	300	290	3.3
9	40	15	160	170	6.3
10	54	37	290	290	0.0
11	36	16	160	165	3.1
12	38	12	145	150	3.4
Average error					4.5

^a The gravimetric determinations herein recorded were made by Mr. J. Gonzales y Nuñez, inorganic chemist, Bureau of Science.

SUMMARY

Two methods have been described for the rapid determination in the field of the total hardness of water. Both methods have been shown to be applicable to field investigations, though preference has been given to the second procedure. The latter has been employed, with satisfactory results, for the past eight months in connection with the water survey made by the Bureau of Science.

SOME GENERALIZATIONS ON THE INFLUENCE OF SUBSTANCES ON CEMENT AND CONCRETE ¹

By J. C. WITT

(From the Laboratory of General, Inorganic, and Physical Chemistry,
Bureau of Science, Manila)

The great variety of uses which modern industry is finding for concrete is continually presenting new problems for research and likewise increasing the importance of work that was completed at a time when the theoretical side was perhaps the only one under consideration. I refer especially to the sensitiveness of cement to many substances and to the destructive chemical action of some external agencies on concrete. The presence of any one of a number of organic or inorganic substances in the water or aggregates used in mixing concrete may seriously interfere with the work or later result in its failure. Even after concrete has been properly made and placed and the work has not failed in either quality or design, it sometimes happens that the construction is not permanent, because it comes into contact with some destructive substance.

This field of research is becoming more important year by year, because of the many new demands being made on the material. Sewer and drain pipe, storage tanks for various liquids, and even boats are now made of concrete. Therefore it is not surprising that the material should be called upon to resist conditions which were not known a few years ago. These agencies may be encountered in a number of ways. For instance, a sewer pipe may be capable of resisting the ordinary substances found in sewage, but may be injured by some industrial waste material which has found its way into the drainage system. Storage tanks may be constructed for a liquid in the belief that they will be satisfactory, but later it may be found that the liquid acts on the concrete, either injuring the tank or contaminating the liquid.²

It is highly desirable that as many substances as possible be investigated in relation to their effect on cement, so that the presence of harmful ones may be avoided in mixing concrete

¹ Received for publication May 2, 1917.

² Cf. Rohland, P., *Beton u. Eisen* (1914), 13, 341; *Feuerungstechnik* (1914), 2, 360. Sartori, A., *Chem. Zeitg.* (1915), 39, 957. Hinzlemann, R., *Journ. Soc. Chem. Ind.* (1904), 23, 995.

and that the finished construction may be protected from them. Although it does not follow that the effect of a substance on cement as shown in the laboratory will necessarily be duplicated with concrete in practice, nevertheless such research is useful in indicating what substances are likely to cause trouble.

The literature since 1889, when Chandlot³ made the important observation that certain substances affect the setting of cement, contains many papers on the subject. Some of these are simply reports of observed failures of concrete, while others are the result of much careful labor. At first it appears that the subject must be fairly well covered, but a study of the papers reveals that there is not much agreement among the various investigators. Table I shows an alphabetical list of electrolytes that have been studied relative to their effect on cement. When the same one is mentioned in more than one paper, the references have been arranged chronologically.

TABLE I.—*Effect of electrolytes on cement, as reported by a number of investigators.*

Aluminium chloride. Dobrzynski, *Journ. Soc. Chem. Ind.* (1892), 11, 525.

A cement was gauged with water and with ammonium chloride solutions, ranging from 1 to 6 per cent. The lower concentration resulted in an increased tensile strength for 7-day briquettes, while the reverse was true with the higher concentrations. All the solutions lowered the strength of 28-day briquettes.

Aluminium chloride. P. Rohland, *Ber. d. deutsch. chem. Ges.* (1901), 33, 2831.

The set was accelerated; no details are given.

Aluminium chloride. P. Rohland, *Zeitschr. f. angew. Chem.* (1903), 16, 1049.

The original setting time of a cement was five hours and eight minutes. It was accelerated to one hour and eight minutes by using a 5.5 per cent aluminium chloride solution. With a 9 per cent solution the setting time was four hours and fifty-nine minutes.

Ammonium sulphate. L. Perin, *Journ. Soc. Chem. Ind.* (1906), 25, 812.

Ammonium sulphate (0.86 per cent) has a greater influence on the set of cement than an equivalent amount of calcium sulphate (on the basis of the sulphuric anhydride content).

Barium chloride. Dobrzynski, *Journ. Soc. Chem. Ind.* (1892), 11, 525.

A cement was gauged with a solution of barium chloride, ranging from 1 to 6 per cent. The tensile strength was considerably increased in every case.

Boric acid. P. Rohland, *Ber. d. deutsch. chem. Ges.* (1901), 33, 2831.

The set was retarded; no details are given.

³ Chandlot, *Journ. Soc. Chem. Ind.* (1889), 8, 543.

- Calcium chloride.** Chandlot, Journ. Soc. Chem. Ind. (1889), 8, 543.
The set was retarded.
- Calcium chloride.** P. Rohland, Ber. d. deutsch. chem. Ges. (1901), 33, 2831.
The set was accelerated; no details are given.
- Calcium chloride.** N. Ljamin, Journ. Soc. Chem. Ind. (1902), 21, 972.
Small amounts retard the set; large amounts accelerate it.
- Calcium chloride.** P. Rohland, Zeitschr. f. angew. Chem. (1903), 16, 1049.
A cement gauged with calcium chloride solutions from 11.10 per cent to 25.90 per cent showed constantly decreasing setting time. The maximum change was from nine hours and thirty minutes to five hours.
- Calcium chloride.** R. C. Carpenter, Eng. Rec. (1904), 50, 769.
An addition of 0.5 per cent produced the greatest retardation.
This amount had no injurious effect on the ultimate strength.
- Calcium chloride.** O. von Blaese, Journ. Soc. Chem. Ind. (1907), 26, 19.
The maximum retardation was produced with a 2 per cent solution.
- Calcium chloride.** P. Rohland, Journ. Soc. Chem. Ind. (1909), 28, 23.
A small amount retards the set, but a large amount accelerates it.
- Calcium chloride.** Spielgeberg, Journ. Soc. Chem. Ind. (1909), 28, 1131.
The effect varies with the composition and general properties of the cement.
- Calcium chloride.** H. Burchartz, Journ. Soc. Chem. Ind. (1910), 29, 1108.
A small addition retards the set, while a larger one accelerates it.
Four samples which were mixed with 20 per cent of the salt failed in soundness.
- Calcium chloride.** O. Kallauner, Z. Betonbau (1914), No. 2; Mitt. Cent. Förd. Deut. Port. Cement Ind., 3, 213. [Chem. Abst. (1914), 8, 2236.]
It decreases the strength. The author believes that all soluble calcium salts decompose cement.
- Calcium chromate.** P. Rohland, Ber. d. deutsch. chem. Ges. (1901), 33, 2831.
It retards the set. No details are given.
- Calcium hydroxide.** R. C. Carpenter, Eng. Rec. (1904), 50, 769.
Slaked lime (2 to 4 per cent), added to a cement which had become quick setting, restored it to normal.
- Calcium nitrate.** Chandlot, Journ. Soc. Chem. Ind. (1889), 8, 543.
The set is retarded.
- Calcium nitrate.** O. Kallauner, Z. Betonbau (1914), No. 2; Mitt. Cent. Förd. Deut. Port. Cement Ind., 3, 213. [Chem. Abst. (1914), 8, 2236.]
There is a decrease in strength.
- Calcium oxychloride.** F. Hauenschield, Journ. Soc. Chem. Ind. (1902), 21, 175.
The strength of specimens stored in air is increased, but the reverse is true of specimens stored in water.

- Calcium sulphate.** Chandlot, Journ. Soc. Chem. Ind. (1889), 8, 543.
The set is retarded.
- Calcium sulphate.** L. Deval, Journ. Soc. Chem. Ind. (1902), 21, 971.
It produces a change of form and an increase in volume with a tendency to diminish the tensile strength. It has no effect on nonaluminium cements nor on those low in calcium.
- Calcium sulphate.** R. C. Carpenter, Eng. Rec. (1904), 50, 769.
The maximum setting time was obtained with an addition of 1.5 per cent.
- Calcium sulphate.** P. Rohland, Zeitschr. f. angew. Chem. (1905), 18, 327.
The effect varies for nearly every cement, depending on the size of grain, the chemical composition, etc.
- Calcium sulphate.** L. Perin, Journ. Soc. Chem. Ind. (1906), 25, 812.
Plaster of paris and raw gypsum (containing equivalent amounts of sulphuric anhydride) have the same effect.
- Calcium sulphate.** Spiegelberg, Journ. Soc. Chem. Ind. (1909), 28, 1131.
The effect varies from the composition of the cement.
- Calcium sulphate.** W. C. Reibling and F. D. Reyes, Phil. Journ. Sci., Sec. A (1911), 6, 225.
The maximum retardation is produced with 2 to 3 per cent of calcium sulphate.
- Calcium sulphate.** O. Kallauner, Z. Betonbau (1914), No. 2; Mitt. Cent. Förd. Deut. Port. Cement Ind., 3, 213. [Chem. Abst. (1914), 8, 2236.]
Temporarily the strength is increased.
- Calcium sulphate.** J. C. Witt, and F. D. Reyes, Phil. Journ. Sci., Sec. A (1917), 12, 133.
Six brands of cement were tested with additions of calcium sulphate. In general, the maximum retardation of set was produced by 1.5 to 2 per cent sulphuric anhydride. Lower tensile strength and high expansion in sea water resulted when more than 3 per cent was present.
- Calcium sulphide.** N. Ljamin, Journ. Soc. Chem. Ind. (1902), 21, 972.
Calcium sulphide forms an insoluble compound with calcium hydroxide, but the effect is relatively low, because about 3 parts of the sulphide are required to combine with 1 part of the hydroxide.
- Calcium sulphate.** O. Kallauner, Z. Betonbau (1914), No. 2; Mitt. Cent. Förd. Deut. Port. Cement Ind., 3, 213. [Chem. Abst. (1914), 8, 2236.]
Temporarily the strength is increased.
- Calcium thiosulphate.** O. Kallauner, Z. Betonbau (1914), No. 2; Mitt. Cent. Förd. Deut. Port. Cement Ind., 3, 213. [Chem. Abst. (1914), 8, 2236.]
Temporarily the strength is increased.

Carbon dioxide (aqueous solution). N. Ljamin, Journ. Soc. Chem. Ind. (1902), 21, 972.

A pronounced accelerating effect is noted, though the solubility of the gas in water is low.

Carbon dioxide. C. Montemartini, Journ. Soc. Chem. Ind. (1908), 27, 228.

When dry, cement is treated with a current of dry carbon dioxide; no change is apparent.

Ferrous sulphate. French patent 408,060, Journ. Soc. Chem. Ind. (1910), 29, 631.

The addition of 1 to 3 per cent ferrous sulphate is said to quicken the set and increase the strength.

Lithium chloride. P. Rohland, Ber. d. deutsch. chem. Ges. (1901), 33, 2831.

There is no effect.

Magnesium chloride. Dobrzynski, Journ. Soc. Chem. Ind. (1892), 11, 525.

The concentration of the solutions was from 1 to 6 per cent. The lower percentages causes a slight increase in tensile strength, while the higher ones causes a slight decrease.

Magnesium chloride. O. von Blaese, Journ. Soc. Chem. Ind. (1907), 26, 19.

The maximum setting time is obtained with 6 per cent of the salt.

Potassium aluminium sulphate. L. Perrin, Journ. Soc. Chem. Ind. (1906), 25, 812.

When cement is mixed with 1.54 per cent of the salt, the setting time is unchanged. The author believes that the presence of aluminium is responsible for the negative effect.

Potassium carbonate. N. Ljamin, Journ. Soc. Chem. Ind. (1902), 21, 972.

No comments are made.

Potassium dichromate. P. Rohland, Ber. d. deutsch. chem. Ges. (1901), 33, 2831.

The set is retarded. No details are given.

Potassium dichromate. P. Rohland, Journ. Soc. Chem. Ind. (1909), 28, 23.

The set is retarded.

Potassium sulphate. P. Rohland, Zeitschr. f. angew. Chem. (1903), 16, 1049.

The set is retarded or accelerated, depending on conditions.

Sodium bisulphite. H. Luftschitz, Tonind-Zeitg. (1913), 37, 1986.

The salts were mixed with cement in various proportions from 0.5 to 4 per cent, and tests were made for tensile and compressive strength. The strength of the specimens decreases with increased amount of salts.

Sodium borate. P. Rohland, Ber. d. deutsch. chem. Ges. (1901), 33, 2831.

The set is retarded. No details are given.

Sodium borate. P. Rohland, Journ. Soc. Chem. Ind. (1909), 28, 23.

The set is retarded.

- Sodium carbonate.** P. Rohland, *Ber. d. deutsch. chem. Ges.* (1901), **33**, 2831.
The set is accelerated. No details are given.
- Sodium carbonate.** N. Ljamin, *Journ. Soc. Chem. Ind.* (1902), **21**, 972.
No comments are made.
- Sodium carbonate.** P. Rohland, *Zeitschr. f. angew. Chem.* (1903), **16**, 1049.
The set is first retarded and then accelerated. The results were similar but different in degree for the several cements investigated.
- Sodium carbonate.** P. Rohland, *Journ. Soc. Chem. Ind.* (1909), **28**, 23.
The set is accelerated.
- Sodium chloride.** Chandlot, *Journ. Soc. Chem. Ind.* (1889), **8**, 543.
It has no influence on either set or tensile strength.
- Sodium chloride.** Dobrzynski, *Journ. Soc. Chem. Ind.* (1892), **11**, 525.
Sodium chloride solutions from 1 to 6 per cent were employed; most of them caused a slight increase in the 7-day strength and a slight decrease in the 28-day strength.
- Sodium chloride.** P. Rohland, *Ber. d. deutsch. chem. Ges.* (1901), **33**, 2831.
It has no effect. No details are given.
- Sodium chloride.** N. Ljamin, *Journ. Soc. Chem. Ind.* (1902), **21**, 972.
No comments are made.
- Sodium chloride.** P. Rohland, *Journ. Soc. Chem. Ind.* (1909), **28**, 23.
Small quantities have no effect.
- Sodium chloride.** A. Passow, *Tonind. Zeitg.* (1914), **38**, 995.
Strength is increased by adding 0.5 to 1 per cent sodium chloride by immersing the specimens in a salt solution. The effect is attributed to the increased solubility of calcium hydroxide in sodium chloride solution.
- Sodium sulphate.** P. Rohland, *Ber. d. deutsch. chem. Ges.* (1901), **33**, 2831.
The set is retarded. No details are given.
- Sodium sulphate.** P. Rohland, *Journ. Soc. Chem. Ind.* (1909), **28**, 23.
The set is retarded.
- Sodium sulphide.** J. C. Witt, *Phil. Journ. Sci., Sec. A* (1916), **11**, 273.
Small amounts retard the set, but larger amounts accelerate it.
The tensile strength is decreased. In general, the cements highest in iron are most affected.

Table I reveals that, regardless of the value of each paper when considered alone, the general subject shows little progress.⁴ Aside from certain substances which have been investigated in great detail by a number of workers—such as calcium sulphate—it is impossible to find much definite information in the literature. In some cases an electrolyte has been investigated by only one worker. As a rule, one paper does not cover sufficient ground to make the work of general value. This is true

⁴Cf. Desch, C. H., *The Chemistry and Testing of Cement*. Edward Arnold, London (1911), 127.

of boric acid, barium chloride, calcium oxychloride, calcium thiosulphate, and lithium chloride. When a substance has been investigated by a number of persons, it often happens that conflicting statements are published. According to Chandlot and Rohland,⁵ sodium chloride has no effect on cement, but Dobrzynski and Passow say that it increases the tensile strength. Rohland classes sodium carbonate as an accelerator of the set of cement, while in a previous paper he stated that it might either retard or accelerate it. Similar disagreements on the effect of calcium chloride may be found, though its general effect on the set has been established. One interesting example of disagreement is that of ferrous compounds. Desch⁶ is of the opinion that if any ferrous iron is present in cement it may be converted into ferrous sulphide by calcium sulphide, which is produced by the reducing action of the fuel. Ferrous sulphide is considered objectionable because of its ability to become oxidized, which would result in a change in volume. However, there is a French patent for the right to add from 1 to 3 per cent dry ferrous sulphate to cement. It is claimed that this will accelerate the set and increase the strength. The general effect of calcium sulphate is perhaps better known than that of any other substance, because so much research has resulted from its use in the manufacture of cement. However, there are still many conflicting views on the rôle of the substance in controlling the set and the amount that can be added without endangering the quality.⁷

The causes that have thus far prevented many of the investigations carried on by various workers from being comparable may be divided into two classes:

1. Details that either cannot be controlled by the investigator or which can be controlled only with considerable difficulty. These include the individual characteristics of cements, resulting from the composition of the raw materials and the methods of manufacture; the personal equation of the investigator; variations in temperature and humidity due to change of season and to location; and differences in apparatus and methods of procedure in various countries. Most of these points do not require explanation. It is well known that cements of the same chemical analysis may be entirely different in their physical properties. While it would be possible to control the temperature and humidity of laboratories so that cement could always be tested

⁵ See Table I.

⁶ Desch, C. H., *op. cit.*, 75.

⁷ Cf. Witt, J. C., and Reyes, F. D., *This Journal*, *Sec. A* (1917), 12, 133.

under the same conditions, the time and expense would be hardly justified.

2. Details which can be easily controlled by the investigator. These include the adoption of some definite plan for the work, so that results obtained with different substances may be directly comparable in so far as the concentration and purity of the solutions employed are concerned; analysis and physical tests of all cements as received; the choice of a sufficient number of cements so that results may be considered as averages.

Chemical and physical tests of all cements investigated should be made because the results may point out the constituent of the cement that is most concerned in the observed results. The conditions under which work is carried on, including the average temperature, humidity, and laboratory methods, should be given because they are of recognized importance. As a rule, solutions are made on the percentage basis and are not afterward analyzed. The results obtained are not directly comparable in some respects. For instance, it usually happens that no account is taken of atomic weights and valencies. An investigator may make solutions of aluminium chloride and sodium chloride and compare results obtained by the same percentage concentrations of each, and yet aluminium chloride contains a much higher percentage of chlorine than does sodium chloride. Likewise in comparing the relative effects of calcium chloride and calcium sulphate the percentage basis is not the proper one.

It is apparent that much progress cannot be made in this field of investigation until the results of various workers can be connected by certain generalizations. The points of basic importance are:

1. Does the effect of an electrolyte depend on the negative ion, the positive ion, or on both?
2. Is the degree of solubility of the corresponding calcium salt important?
3. Can the effect of an untried electrolyte be predicted from results obtained with others?
4. Can the observed effect be traced to any particular constituent of the cement?

When 1 and 2 have been determined for a large number of electrolytes, it should be possible to predict the effect of an untried electrolyte—at least qualitatively—on many cements. Number 4 is of great practical importance. Such data could be used as a factor in determining the cement best suited for construction that is to be exposed to certain conditions. This has been already taken advantage of in the study of the effect

of sea water on cement. It has been shown for some cements that the iron content is one of the factors which determines the effect of sodium sulphide.⁸

This paper presents experiments that have been undertaken in an effort to correlate investigations in this field of research.

EXPERIMENTAL WORK

Two barrels each of four brands of cement were chosen. Each barrel was carefully sampled, and the cement was then preserved in suitable containers during the progress of the work. The results of the chemical analysis and the physical tests of the cements as received in the laboratory are given in Tables II and III.

TABLE II.—*Chemical analysis of cements.*

[Numbers give percentages.]

	I.	II.	III.	IV.
Loss on ignition	2.43	2.15	2.17	3.24
Silica (SiO ₂)	22.60	21.40	21.26	20.62
Alumina (Al ₂ O ₃)	7.72	7.58	8.54	6.62
Ferric oxide (Fe ₂ O ₃)	1.76	1.70	2.08	2.56
Calcium oxide (CaO)	61.32	62.94	62.82	63.50
Magnesia (MgO)	1.08	1.37	1.13	1.43
Sulphuric anhydride (SO ₃)	1.45	1.61	1.02	0.82
Sodium and potassium oxides (Na ₂ O, K ₂ O)	1.63	1.14	1.17	1.33

TABLE III.—*Physical tests of cements as received.*

Brand.	Fineness.		Specific gravity.	Initial set.	Final set.	Tensile strength in kilos per square centimeter.			Tensile strength in pounds per square inch.		
	200-mesh.	100-mesh.				7 days.	28 days.	180 days.	7 days.	28 days.	180 days.
I	81.1	97.0	3.12	Hrs. min. 4 5	Hrs. min. 6 48	18.7	25.3	25.6	267	359	365
II	83.7	97.0	3.10	3 56	5 44	19.7	24.6	26.2	280	351	378
III	85.7	98.2	3.12	3 36	6 12	22.5	27.4	29.0	321	389	413
IV	83.7	89.4	3.10	3 46	6 47	15.4	20.9	26.2	218	297	373

The following electrolytes were chosen:

Sodium chloride.	Sodium sulphate.
Zinc chloride.	Zinc sulphate.
Copper chloride.	Copper sulphate.
Sodium nitrate.	Sodium bicarbonate.
Potassium nitrate.	Potassium bicarbonate.
Ammonium nitrate.	

⁸ Op. cit.

If a cement is gauged with solutions of several chlorides, containing the same amount of chlorine per liter, it should give the same results, aside from the experimental error, as far as the chlorine ion is concerned. In the same way, if we gauge a cement with solutions of several salts of sodium, for example, having the same amount of sodium per liter, we have a basis for comparing the effect of the negative ion. Further, by using a number of salts that form soluble calcium compounds and a number of others that produce difficultly soluble calcium compounds, we should be able to obtain data on the question of whether or not there is any relation between the effect of electrolytes and the solubility of the calcium compounds which they produce.

A stock solution of each electrolyte was first made and standardized. This was normal on the basis of the negative ion. Various dilutions were then made as needed. Care was taken to choose no electrolyte that contained the principal metallic elements found in cement, such as calcium and aluminium, or any that contained metals that might assume the same rôle, such as iron and magnesium. The data on all solutions employed are given in Table IV.

Mortar briquettes were made from each cement, using water and four concentrations of each of the eleven solutions mentioned; also setting time⁹ and soundness tests were made on each cement with each solution. The approximate average temperature was 30° C., and the average relative humidity was about 80 per cent. All the tests were made in accordance with United States Government specifications for Portland cement.¹⁰ The normal consistency of each cement was determined with the various solutions. The results are shown in Table V, VI, and VII.

⁹ Each cement used in this investigation contains calcium sulphate. Consequently when a cement is gauged with a solution of an electrolyte, the observed setting time may be included the resultant of the effect of the two substances.

¹⁰ See Circular 33, United States Bureau of Standards, Washington, Government Printing Office (1912).

TABLE IV.—Data on solutions employed.

Salt.	Normality.	Grams of salt per cubic centimeter (by analysis).	Centimeters of solution required for normal consistency. ^a	Parts by weight per 100 grams of cement.		
				Of salt.	Of positive radical.	Of negative radical.
Sodium chloride -----	0.05	0.0029	22	0.0640	0.0252	0.0388
	0.10	0.0058	23	0.1339	0.0527	0.0812
	0.50	0.0291	23	0.6695	0.2634	0.4061
	1.00	0.0582	22	1.2810	0.5040	0.7770
Zinc chloride -----	0.05	0.0034	22	0.0753	0.0361	0.0392
	0.10	0.0068	23	0.1575	0.0756	0.0819
	0.50	0.0342	23	0.7874	0.3779	0.4055
	1.00	0.0685	22	1.5065	0.7226	0.7839
Copper chloride -----	0.05	0.0034	22	0.0741	0.0351	0.0390
	0.10	0.0067	23	0.1549	0.0732	0.0817
	0.50	0.0337	23	0.7745	0.3663	0.4082
	1.00	0.0674	22	1.4824	0.7011	0.7813
Sodium nitrate -----	0.05	0.0043	22	0.0937	0.0253	0.0684
	0.10	0.0085	23	0.1959	0.0530	0.1419
	0.50	0.0426	23	0.9795	0.2650	0.7145
	1.00	0.0852	22	1.8739	0.5069	1.3670
Potassium nitrate -----	0.05	0.0051	22	0.1116	0.0432	0.0684
	0.10	0.0102	23	0.2334	0.0904	0.1430
	0.50	0.0508	23	1.1670	0.4520	0.7150
	1.00	0.1015	22	2.2332	0.8646	1.3686
Ammonium nitrate -----	0.05	0.0040	22	0.0883	0.0199	0.0684
	0.10	0.0080	23	0.1846	0.0416	0.1430
	0.50	0.0401	23	0.9230	0.2079	0.7151
	1.00	0.0803	22	1.7659	0.3978	1.3681
Sodium sulphate -----	0.05	0.0036	22	0.0785	0.0254	0.0531
	0.10	0.0071	23	0.1643	0.0532	0.1111
	0.50	0.0357	23	0.8215	0.2661	0.5554
	1.00	0.0714	22	1.5719	0.5091	1.0628
Zinc sulphate -----	0.05	0.0040	22	0.0886	0.0359	0.0527
	0.10	0.0081	23	0.1852	0.0751	0.1101
	0.50	0.0403	23	0.9260	0.3753	0.5507
	1.00	0.0806	23	1.7721	0.7181	1.0540
Copper sulphate -----	0.05	0.0040	22	0.0881	0.0351	0.0530
	0.10	0.0080	23	0.1843	0.0734	0.1109
	0.50	0.0401	23	0.9215	0.3672	0.5543
	1.00	0.0801	22	1.7628	0.7025	1.0603
Sodium ^b bicarbonate -----	0.05	0.0020	22	0.0447	0.0125	0.0316
	0.10	0.0041	23	0.0935	0.0262	0.0661
	0.50	0.0203	22	0.4472	0.1259	0.3163
	1.00	0.0407	22	0.8947	0.2509	0.6327
Potassium ^b bicarbonate -----	0.05	0.0024	22	0.0538	0.0185	0.0318
	0.10	0.0049	23	0.1126	0.0449	0.0663
	0.50	0.0245	23	0.5629	0.2246	0.3319
	1.00	0.0489	22	1.0769	0.3706	0.6365

^a The normal consistency values given in this column are averages for the four cements. In nearly every case the variation was only 1 or 2 per cent. In gauging cement IV with 0.50 N copper sulphate and with 0.50 N potassium bicarbonate, however, the normal consistency was unusually high, being 26 and 28 per cent, respectively. These two values were not counted in the averages given here.

^b The concentrations of these solutions are based on the amount of CO₂ present. They are only half the indicated concentrations with respect to alkalinity.

TABLE V.—Effect on tensile strength (1:3 mortar).
KILOGRAMS PER SQUARE CENTIMETER.

Solution.	Normality.	Cement I.			Cement II.			Cement III.			Cement IV.		
		7 days.	28 days.	180 days.	7 days.	28 days.	180 days.	7 days.	28 days.	180 days.	7 days.	28 days.	180 days.
Water	0.05	18.8	25.2	25.6	19.7	25.0	26.2	22.6	27.3	29.0	15.3	20.9	26.2
	0.10	15.0	18.5	17.2	14.1	16.7	19.0	18.8	23.2	24.1	12.7	18.5	22.7
	0.50	14.3	20.9	23.5	14.8	20.5	22.1	14.7	20.4	24.9	10.7	15.4	22.0
Sodium chloride	0.10	17.1	23.2	28.1	19.3	21.5	26.7	16.4	21.7	24.6	10.4	20.4	22.8
	0.50	18.8	27.2	29.5	16.5	20.8	25.3	21.3	26.6	26.2	13.8	16.6	22.8
	1.00	16.5	19.3	20.8	14.8	18.3	19.8	18.6	24.2	26.1	13.7	18.6	24.9
Zinc chloride	0.10	14.9	16.2	23.2	17.7	22.9	24.2	19.2	22.6	29.5	10.9	17.5	22.1
	0.50	18.5	27.5	32.7	19.9	27.8	33.2	20.7	27.9	30.1	16.3	20.7	29.2
	1.00	17.1	24.1	33.3	17.6	23.4	30.2	20.5	25.9	25.6	13.8	21.6	30.5
Copper chloride	0.05	15.4	20.7	23.2	12.7	17.8	19.0	15.2	27.4	24.7	11.9	14.2	25.6
	0.10	15.6	22.9	21.7	14.2	18.4	26.1	16.2	22.4	28.8	9.9	16.2	22.5
	0.50	9.8	26.0	31.6	10.7	26.4	29.4	17.5	24.5	31.6	6.9	15.9	25.7
Sodium nitrate	1.00	12.2	22.4	33.3	17.1	23.4	28.5	17.4	28.2	31.8	12.9	19.9	27.7
	0.05	14.4	20.4	22.1	14.9	16.7	19.1	19.1	24.7	24.9	11.6	16.3	24.0
	0.10	13.6	21.0	21.8	16.3	21.2	23.5	15.0	23.8	26.4	9.1	12.3	21.5
Potassium nitrate	0.50	19.1	28.2	30.6	16.4	21.5	25.4	13.5	21.2	23.9	7.4	11.7	20.4
	1.00	13.0	22.0	27.0	13.7	20.4	23.9	12.5	21.0	26.3	9.2	16.3	23.5
	0.05	14.7	18.4	19.9	13.3	17.9	19.2	19.7	23.6	23.9	11.6	16.7	21.0
Ammonium nitrate	0.10	15.1	19.7	25.6	15.9	22.9	24.3	16.5	23.6	25.5	9.5	12.7	20.4
	0.50	13.7	18.7	25.3	14.4	20.7	23.8	11.8	17.2	22.9	8.1	12.5	21.8
	1.00	15.2	21.1	23.6	14.3	20.3	22.1	17.5	21.8	22.1	9.7	14.2	22.5
Ammonium nitrate	0.05	15.6	20.2	20.4	17.0	18.9	22.0	18.8	23.1	22.8	11.8	17.4	24.2
	0.10	17.5	21.5	24.5	17.0	20.2	22.0	15.7	22.8	22.8	9.2	13.6	21.0
	0.50	16.4	22.3	31.6	21.0	25.6	29.4	14.7	23.9	26.2	8.9	13.9	23.5
1.00	21.2	28.3	30.9	20.6	27.4	27.1	19.1	23.2	33.0	12.0	18.9	25.6	

TABLE V.—Effect on tensile strength (1:3 mortar)—Continued.
POUNDS PER SQUARE INCH.

Solution.	Normal-ity.	Cement I.			Cement II.			Cement III.			Cement IV.		
		7 days.	28 days.	180 days.	7 days.	28 days.	180 days.	7 days.	28 days.	180 days.	7 days.	28 days.	180 days.
		Water	267	359	385	280	351	373	321	389	413	218	287
Sodium chloride	0.05	214	264	246	202	238	269	268	330	343	182	264	323
	0.10	205	296	385	210	292	316	208	290	355	183	218	313
	0.50	243	330	401	275	307	379	233	308	349	149	290	324
Zinc chloride	1.00	267	387	421	235	295	359	308	378	373	197	236	324
	0.05	235	275	295	210	267	282	265	345	372	196	265	366
	0.10	212	230	329	262	327	344	278	321	420	156	249	315
Copper chloride	0.50	263	393	467	284	396	473	293	397	428	231	294	417
	1.00	244	344	476	250	383	430	391	368	365	197	307	436
	0.05	218	294	331	183	254	270	216	390	352	170	203	365
Sodium nitrate	0.10	221	326	308	203	262	372	230	319	409	141	230	321
	0.50	140	370	450	153	361	418	249	348	450	99	226	367
	1.00	176	319	474	244	333	407	247	403	453	185	284	395
Potassium nitrate	0.05	206	290	316	211	288	272	271	352	354	166	282	342
	0.10	195	298	310	301	301	336	213	339	377	130	307	377
	0.50	272	401	437	233	307	362	194	302	340	107	168	291
Ammonium nitrate	1.00	187	313	386	196	290	339	179	299	374	132	282	336
	0.05	209	261	283	190	265	273	280	337	341	166	238	298
	0.10	215	280	364	227	326	347	235	336	336	136	182	291
Ammonium nitrate	0.50	197	266	361	208	298	333	168	245	327	116	179	309
	1.00	217	300	337	207	289	316	249	310	316	139	203	319
	0.05	221	288	290	241	268	287	267	329	326	169	247	345
Ammonium nitrate	0.10	249	306	348	242	288	313	224	325	325	183	195	298
	0.50	233	318	415	299	365	418	208	340	373	127	199	334
	1.00	301	404	439	282	390	387	272	330	469	171	268	366

Sodium sulphate	0.05	277	288	223	286	327	302	410	487	179	228	321
	0.10	316	337	239	286	340	266	324	387	150	220	316
	0.50	308	370	246	355	364	184	281	370	140	205	345
Zinc sulphate	1.00	385	449	300	356	421	282	345	480	223	323	396
	0.05	286	288	258	323	313	263	385	392	201	262	341
	0.10	318	353	231	311	359	267	334	370	183	248	349
Copper sulphate	0.50	430	469	283	366	475	250	365	442	226	338	417
	1.00	385	524	263	386	466	300	413	452	272	367	419
	0.05	330	351	250	345	361	277	366	373	182	231	361
Sodium bicarbonate	0.10	329	358	219	295	308	252	352	351	165	235	321
	0.50	366	495	191	340	461	168	311	383	120	284	391
	1.00	250	413	156	362	394	253	423	526	135	316	400
Potassium bicarbonate	0.05	339	365	242	262	276	278	342	349	171	246	339
	0.10	297	343	270	287	310	221	308	327	147	227	346
	0.50	315	406	224	311	370	173	264	368	195	147	283
Potassium bicarbonate	1.00	335	415	251	323	323	226	307	365	185	234	247
	0.05	234	257	226	249	288	280	363	370	207	236	351
	0.10	197	330	243	321	353	251	332	365	165	216	339
Potassium bicarbonate	0.50	369	421	243	303	394	188	256	363	98	109	274
	1.00	272	343	234	308	346	246	309	360	152	247	277

TABLE VI.—Effect on initial set.*

Brand.	Gauged with water.	Normality of solution.	Sodium chloride.		Zinc chloride.		Copper chloride.		Sodium nitrate.		Potassium nitrate.		Ammonium nitrate.		Sodium sulphate.		Zinc sulphate.		Copper sulphate.		Sodium bicarbonate.		Potassium bicarbonate.	
			Hrs. min.	Hrs. min.	Hrs. min.	Hrs. min.	Hrs. min.	Hrs. min.	Hrs. min.	Hrs. min.	Hrs. min.	Hrs. min.	Hrs. min.	Hrs. min.	Hrs. min.	Hrs. min.	Hrs. min.	Hrs. min.	Hrs. min.	Hrs. min.	Hrs. min.	Hrs. min.	Hrs. min.	Hrs. min.
I	4 5	0.05	6 10	6 2	7 26	5 43	6 35	6 27	6 20	6 38	6 29	6 20	5 47											
			4 24	4 59	11 37	4 17	4 17	4 15	4 48	12 39	4 41	4 45												
			5 5	10 9	14 23	4 33	4 55	4 12	4 27	5 26	14 40	5 0	4 55											
			5 54	26 9	19 50	4 31	5 30	5 52	4 30	6 25	19 45	4 25	3 30											
			7 13	7 9	6 52	5 49	6 20	5 41	5 37	7 37	7 24	5 58	6 13											
II	3 36	0.10	6 11	15 42	15 17	6 38	5 45	6 13	6 1	14 35	16 11	6 36	6 25											
			5 8	10 7	10 41	5 14	5 23	4 1	5 0	14 58	15 0	5 22	5 20											
			4 6	24 22	22 3	3 40	5 9	2 40	3 44	28 0	26 37	3 28	3 12											
			5 42	7 22	5 14	5 11	4 50	4 28	4 58	6 4	5 45	4 25	5 4											
			4 20	8 27	8 24	4 0	4 3	4 24	5 33	6 40	9 4	4 35	4 29											
III	3 36	0.50	5 4	6 40	6 40	3 56	4 20	4 13	4 31	7 30	10 45	4 15	4 15											
			4 26	25 3	6 47	4 15	3 52	4 10	3 44	25 49	14 48	2 22	4 11											
			6 27	7 7	7 30	6 25	5 36	5 31	6 7	8 3	8 19	6 23	6 2											
			6 16	9 52	12 14	6 15	6 3	5 45	5 55	8 58	9 45	5 41	6 14											
			7 8	9 50	15 7	5 49	7 16	6 7	7 0	7 52 ^a	15 17	3 52	5 6											
IV	3 46	1.00	5 32	25 53	33 47	4 1	5 35	5 1	4 46	24 42	46 37	2 14	3 3											

* Gillmore needles were used. When less than eight hours, the setting-time results are accurate to probably ten or fifteen minutes. When the set is very slow, as in some of the cases here shown, the result depends largely on the judgment of the operator and may be considered only approximate.

DISCUSSION OF RESULTS

Tensile strength.—The general tendency of all the solutions is to decrease the tensile strength. Of the 352 results here recorded (which represent 1,056 briquettes), only 44 show an increase in strength, and as a rule, this increase is small. The greatest number of such cases occurs with the sulphates. The increases occur mostly with cements I and II and with the 1.0 and the 0.5 normal solution.

The decrease in tensile strength is most prominent with the 7-day briquettes, and the principal ones are with the maximum concentration of each solution employed. Cement IV is the most sensitive to the effect of the solutions in lowering the tensile strength. With this cement, every solution used causes one or more series of briquettes to fall below the specified limits. This cement is highest in calcium content.

Setting time.—Apparently there is no relation between the effect of the solutions on the set and on the tensile strength. On the basis of their effect on the set, the salts may be divided into two groups:

1. Sodium chloride, sodium nitrate, potassium nitrate, ammonium nitrate, sodium sulphate, sodium bicarbonate, and potassium bicarbonate.

2. Zinc chloride, copper chloride, zinc sulphate, and copper sulphate.

When a member of the first group is added to a cement, a small amount of the salt causes a retardation of the set. After a maximum point is reached, the set is accelerated by further additions of the substance, until the original setting time is reached or even passed. Within the limits investigated, the behavior of these electrolytes is, in general, similar to many others that have been investigated from time to time, such as sodium sulphide and calcium sulphate.¹¹ The second group shows a retardation with the lowest concentration of each solution employed. The retardation increases with increasing concentration. For the ranges studied the time-concentration curves of these salts rise indefinitely. This is contrary to the corresponding curves of group 1, which pass through maximum points.

Though it was expected that the results would tend to divide the salts into groups, the basis of division indicated by this work was somewhat surprising. This basis is not the solubility

¹¹ Witt, J. C., and Reyes, F. D., loc. cit.

of the resulting calcium compounds nor the negative ion. It is chiefly the positive ion. Both zinc salts and both copper salts show similar effects, whereas the other chlorides and sulphates behave differently. Since calcium sulphate is difficultly soluble and calcium chloride is readily so, no division can be made on that basis. There are one or two exceptions to this effect of the zinc and copper compounds which are difficult to explain. These are the effect of copper chloride on sample III and the effect of zinc sulphate on sample I. However, in most cases all the cements are affected similarly by the same substances.

A number of statements appear in the literature which attempt to account for the effect of electrolytes on cements, but usually there can be found as many exceptions as there are instances of agreement. For instance, Dobrzynski¹³ found that the normal consistency of cement, when gauged with solutions of various chlorides, varied with the solubility of the salt. In the present work, cements gauged with sodium, copper, and zinc chlorides, which differ widely in solubility, showed the same normal consistency (Table IV). Kallauner is of the opinion that all soluble calcium salts decompose cement. This is not in conformity with other work with calcium salts (Table I). Though many believe that the major effect of an electrolyte is due to the effect of the negative ion, especially in so far as this may be able to affect the solubility of the calcium compounds in the cement, the present results do not indicate this. The statement of Rohland in various papers that cement is affected by catalizers positive and negative is not an adequate explanation. There are instances in which the great change in the setting time of cement caused by electrolytes seems to be catalytic, but in most cases the relation between the effect and the amount of the electrolyte present suggests some physical or chemical influence which is not catalysis but which has not as yet been explained.

SUMMARY

Investigation of the effect of certain substances on cement is becoming more important because of new industrial uses for concrete. The practical importance and the theoretical interest of the subject have led to the publication of a number of papers.

A study of these papers reveals that, while a number of them have individual merit, the results are not comparable and the

¹³ References are given in Table I.

subject as a whole shows little progress. One reason for this is that in carrying out investigations no definite plan of attack has been followed.

Because of the complex nature of cements and the great difference in physical and chemical properties, it is believed that complete uniformity of results is not possible, but that qualitative agreement may be hoped for.

The general effect of all the electrolytes studied is to lessen the tensile strength and to modify the set.

On the basis of their effect on the set, the electrolytes may be divided into two groups. The members of one group cause a retardation of the set up to a certain concentration and then cause an acceleration. The members of the other group cause a retardation of the set which increases with the increase of the concentration, until the set is practically destroyed.

With the salts investigated in this paper the positive ion is more important than the negative in determining the effect of an electrolyte on cement. There is no well-established relationship between this effect and the solubility of any calcium compounds that may be formed. More extensive work will be necessary before the effect of an untried electrolyte can be predicated.

506.1
P55
J8

VOL. XIII, SEC. A, No. 2

MARCH, 1918

THE PHILIPPINE JOURNAL OF SCIENCE

ALVIN J. COX, M. A., PH. D.
GENERAL EDITOR

SECTION A
CHEMICAL AND GEOLOGICAL SCIENCES
AND THE INDUSTRIES

EDITED WITH THE COÖPERATION OF

H. C. BRILL, PH. D.; J. R. WRIGHT, PH. D.; G. W. HEISE, M. S.
T. DAR JUAN, A. B., PH. D.; A. H. WELLS, A. B.
R. C. MCGREGOR, A. B.; H. E. KUPFER, A. B.

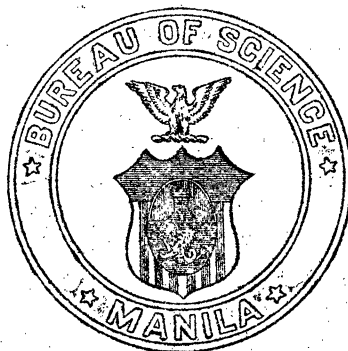

MANILA
BUREAU OF PRINTING
1918

PHILIPPINE JOURNAL OF SCIENCE

A TEN-YEAR INDEX

CONTENTS AND INDEX OF THE PHILIPPINE JOURNAL OF SCIENCE, VOLUME I (1906) TO VOLUME X (1915)

Order No. 449. Bureau of Science Publication No. 8. Paper, 441 pages.
Price \$2, United States currency, postpaid.

One copy of this index has been sent free of charge to each subscriber that has received Volumes XI and XII of the Journal.

This publication consists of:

The complete contents of the first ten volumes of the Philippine Journal of Science, all sections; giving all authors, titles of articles, and page numbers. The exact date of issue of each number is recorded.

An author index, being an alphabetical list of all the contributors. The titles of all the articles are listed under the names of their respective authors.

A subject index. The subject matter is very fully indexed by catch words from the titles, by geographical localities, and by subjects. All systematic names in zoölogy and botany, as well as the thousands of English and local names, are entered in the index.

STUDIES IN PHILIPPINE DIPTERA, II

By M. BEZZI

Order No. 437. Bureau of Science Publication No. 10. Paper, 59 pages and 1 plate.
Price \$0.50, United States currency, postpaid.

This is the second century of Professor Bezzi's enumeration of Philippine species of flies and includes descriptions of new genera and new species.

PLEASE GIVE ORDER NUMBER

Orders for Bureau of Science publications may be sent to the BUSINESS MANAGER, Philippine Journal of Science, Bureau of Science, Manila, P. I., or to any of the following agents:

AGENTS

THE MACMILLAN COMPANY, 64-66 Fifth Avenue, New York, U. S. A.
WM. WESLEY & SON, 28 Essex Street, Strand, London, W. C., England.
MARTINUS NIJHOFF, Lange Voorhout 9, The Hague, Holland.
KELLY & WALSH, Limited, 32 Raffles Place, Singapore, Straits Settlements.
A. M. & J. FERGUSON, 19 Baillie Street, Colombo, Ceylon.
THACKER, SPINK & Co., P. O. Box 54, Calcutta, India.

THE PHILIPPINE
JOURNAL OF SCIENCE

A, CHEMICAL AND GEOLOGICAL SCIENCES
AND THE INDUSTRIES

VOL. XIII

MARCH, 1918

No. 2

THE RADIUM CONTENT OF WATER FROM THE CHINA SEA*

By J. R. WRIGHT¹ and G. W. HEISE
(From the Bureau of Science, Manila)

TWO TEXT FIGURES

The importance of accurate determinations of the radium content of sea water in different parts of the world is just beginning to be fully appreciated. A knowledge of the radium content of the waters of the sea is necessary in a study of such distantly related problems as geological processes and the ionization of the atmosphere with all the consequent questions, such as cloud formation, atmospheric electricity, and transmission of electromagnetic waves around the earth's surface.

Determinations of the radium content of sea water have been made by several investigators, but the determinations have been for the most part limited to the Atlantic Ocean or to the Pacific Ocean in the immediate neighborhood of South America. This is the first record of a determination of the radium content of the water of the China Sea in the vicinity of the Philippines. Throughout this discussion, unless otherwise specified, all results will be expressed in grams $\times 10^{-12}$ per liter of water.

The first attempt to obtain an idea of the amount of radium contained in sea water was made by Strutt,² who determined the radium content of a sample of sea salt. His result reduced

* Received for publication October 22, 1917.

¹ Professor of physics, University of the Philippines.

² On the distribution of radium in the earth's crust, *Proc. Roy. Soc. London, A* (1907), 78, 150-153.

to the above unit gives a value of 2.3. This method, however, is open to objection, and the result obtained is rather uncertain, although valuable as showing the order of magnitude of the quantity to be determined.

Eve,³ in 1907, made a determination of the radium content of Ignau sea salt and also of a sample of sea water from the middle Atlantic and obtained values of 0.3 and 0.6, respectively.

The first extensive series of determinations on sea water was made by Joly⁴ in 1908. His method is described as similar to that used by Strutt with the exception that he boiled his sample under a partial vacuum and finally filled with distilled water in order to drive over all the gas containing emanation into his collecting chamber. In the course of his determinations he found that in order to liberate all the emanation generated in the sample within a given time it was necessary to acidify with hydrochloric acid. Especially was this the case with certain samples. This is probably due to the fact that during concentration any precipitates of barium or of sulphates that may form will tend to carry down with them some of the radium and that the emanation is liberated therefrom with difficulty. He also found that his first determination on a given sample generally gave a value considerably lower than subsequent tests. Consequently in making up his mean for any given sample his first determination was omitted. In a later paper⁵ Joly gives the results for twenty-five samples from the north Atlantic and Indian Oceans. His highest values were obtained for samples collected off the coast of Ireland, the mean value for five different samples being 34. His lowest value was 2.2 for a sample from the Mediterranean. His mean value for the twenty-five samples is given as 16.

Eve,⁶ in 1909, published the results for determinations on six samples of sea water collected at different points in the north Atlantic between Liverpool and Montreal and obtained a value of 0.9 as the mean radium content, the maximum range being from 0.5 to 1.5.

Satterly⁷ made several determinations on sea water from

³ The ionization of the atmosphere over the ocean, *Phil. Mag.* (1907), 13, 248-258.

⁴ The radioactivity of sea-water, *ibid.* (1908), 15, 385-393.

⁵ On the radium content of sea-water, *ibid.* (1909), 18, 396-407.

⁶ On the amount of radium present in sea-water, *ibid.* (1909), 18, 102-107.

⁷ On the radium content of various fresh and sea-waters and some other substances, *Proc. Cam. Phil. Soc.* (1912), 16, 360-364.

regions near the coast of England. He obtained a mean of 1.0, with a maximum range of 0.2 to 1.6. Contrary to Joly's experience Satterly found that his first determination on any given sample was always higher than succeeding tests and concluded that the most probable result was the mean after the first reading had been eliminated.

Lloyd,⁸ in 1915, made three determinations on a sample from the Gulf of Mexico, his mean result being 1.7. Like Joly he also found that the first reading was slightly lower than succeeding ones and consequently omitted it in the determination of his mean value.

On a voyage across the Atlantic from Spain to Chile Knoche⁹ made several determinations by what is commonly called the shaking method. The water was collected from the surface in buckets and tested immediately for the emanation content, an Engler and Sieveking electroscope being used. Unfortunately his results are expressed in maches. As a mean of twelve determinations on the Atlantic he obtained 0.12 mache. Joly, in a summary of Knoche's work, attempts to express Knoche's results in terms of the radium content per liter in grams $\times 10^{-12}$ and calculates that 0.12 mache would be equivalent to 17×10^{-12} grams radium per liter, or, expressed in the unit used throughout this discussion, the mean radium content found by Knoche for the Atlantic would be 17. The value for Knoche's mean as given by Joly is probably much too low. The only satisfactory way of converting from the one unit to the other is to make a direct calibration of the particular instrument by introducing a known quantity of radium emanation. For the electroscope with attached ionization chamber that we used in most of our determinations on the radium content of waters, one mache equals 285×10^{-12} grams radium per liter, and on this basis 0.12 mache would be equivalent to 34.6×10^{-12} grams. The conversion factor is dependent, however, on the constants of the particular instrument and varies rapidly with variation in the capacity. The factor that we obtained for our instrument is lower than that given for most instruments, which inclines us to the belief that the mean value of Knoche's results for the Atlantic Ocean, expressed in grams radium, is much higher than that given by Joly. In estimating the value of Knoche's results

⁸ The radium content of water from the Gulf of Mexico, *Am. Journ. Sci.* (1915), 189, 580-582.

⁹ Einige Bestimmungen der aktiven Emanation des Meerwassers auf dem Atlantischen Ocean, *Phys. Zeitschr.* (1909), 10, 157-158.

in terms of grams radium, Joly made certain assumptions, which, as he states, are all on the side of reducing the final result. Knoche¹⁰ has also made something like thirty determinations for a region in the Pacific Ocean off the coast of Chile and obtained a mean value of 0.043 mache.

Mialock¹¹ has recently made some determinations of the radium content of sea salt in the waters of the Atlantic and Pacific Oceans. We have not been able to obtain access to his original article, and our knowledge of his results is dependent on a brief review appearing in the Chemical Abstracts. His results, however, seem to agree fairly well with those of Knoche.

It is hard to account for the variation in the results of the different investigators. One can easily assume that the radium content varies considerably in different parts of the world, but it is hardly to be expected that there should be a wide variation in any given region. In measuring such minute quantities as the radium in a few liters of sea water, errors in measurement or method are inevitably large, but the large variation noted cannot be accounted for on this basis. In order to get results for widely separated regions that can be directly compared with a fair degree of certainty, it is highly desirable that a standardized method be adopted and even that a uniform type of instrument be used whenever possible.

EXPERIMENTAL RESULTS

Thus far our determinations have been confined to one sample of sea water from the China Sea. The sample was taken from a depth of about 2 meters in the open sea at a distance of approximately 8 kilometers from the entrance to Manila Bay. About forty liters were collected in two large glass bottles, which had been carefully cleaned. Thirty liters were then taken and evaporated to 15 liters on the water bath, pure redistilled hydrochloric acid being added from time to time, so that a slight excess of acid was present during the entire process of concentration. About 25 cubic centimeters of pure hydrochloric acid were then added, and the entire quantity was sealed in a large glass bottle.

¹⁰ Bestimmungen des Emanationgehaltes im Meerwasser und der induzierter Aktivität der Luft zwischen der chilenischen Küste and der Osterinsel, *ibid.* (1915), 13, 112-115.

¹¹ Determination of the radioactive content of the salts in the waters of the Atlantic and Pacific Oceans between Montevideo and El Callao, *Anal. Soc. cient. Argentina* (1915), 79, 267-275.

Since we were dealing with several times the quantity of sea water used in similar tests by previous investigators, we decided to try the charcoal absorption method. This method is fully described in an article by Wright and Smith¹² on the emanation content of atmospheric air. After the water had remained sealed in the flask for a period of thirty days or longer, the flask was placed in a water bath and heated to about 80° C., when the tips of the tubes leading into the bottle were broken, and emanation-free air was pulled through at the rate of 1 liter per minute. The air was then passed through a bottle containing sulphuric acid and a tube containing calcium chloride and finally through two tubes in series, each of which contained 70 grams of finely granulated coconut charcoal. At the same time air was bubbled through an identical system, except that in place of the bottle containing the sea water there was substituted a small bottle containing 615×10^{-12} grams radium from a standard solution furnished by the Bureau of Standards at Washington, D. C. The portion of solution used had been sealed up, after having been freed from all emanation, for a period of exactly twenty-six and one-half hours, so that the emanation obtained from our standard was equivalent to that in equilibrium with 110.7×10^{-12} grams of radium. Air was bubbled through the boiling solutions until we were certain that all the contained emanation had been transferred to our charcoal tubes. Since in a previous work by Wright and Smith¹³ on the quantitative determination of the emanation content of atmospheric air it had been shown that these same charcoal tubes absorb approximately 99 per cent of the emanation passing through them even for much larger quantities of emanation, it was assumed that by this method we would obtain at least as great accuracy as by the more direct method. Moreover this method has the advantage of being a comparative one, so that any errors that are due to inaccuracy of observation will cancel in the final calculations. The arrangement of the apparatus in the collecting system is shown in fig. 1.

After the emanation had been collected in the charcoal tubes, they were heated in an electric furnace, and the gas was driven

¹² The variation with meteorological conditions of the amount of radium emanation in the atmosphere, in the soil gas, and in the air exhaled from the surface of the ground, at Manila, *Phys. Rev.* (1915), n. s. 6, 459-482.

¹³ A quantitative determination of the radium emanation in the atmosphere and its variation with altitude and meteorological conditions, *Phil. Journ. Sci., Sec. A* (1914), 9, 51-76.

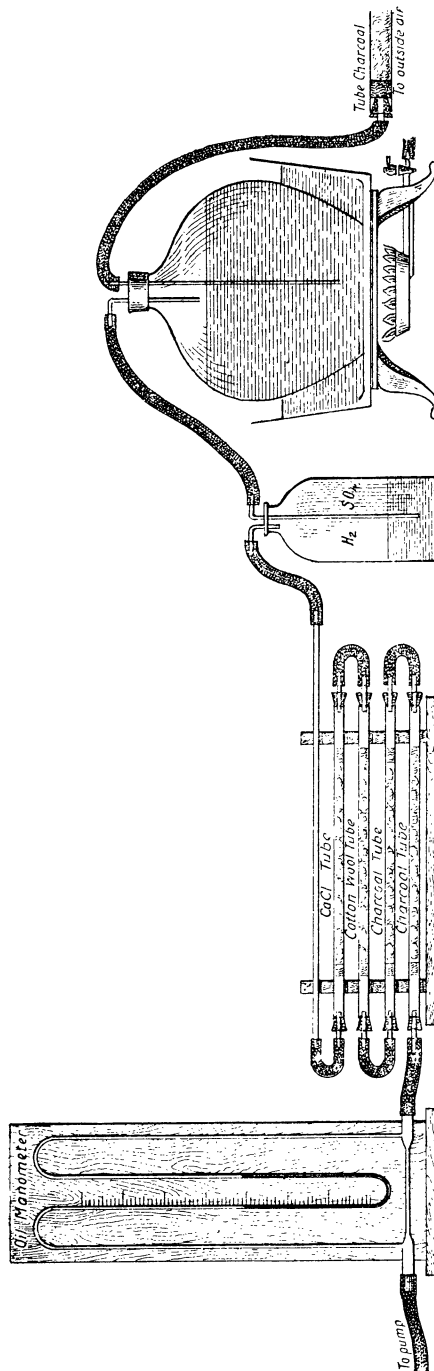

FIG. 1. Apparatus used in charcoal absorption method.

off and collected over water in an aspirator bottle. It was then passed into the ionization chamber of a Spindler and Hoyer electroscope and tested in the usual manner, allowance being made for the decay of emanation in the period elapsing between time of collecting and time of testing. The arrangement of the apparatus in the testing system is shown in fig. 2.

Three separate tests were made by this method. The determinations gave 0.27, 0.16, and 0.17, respectively. The mean of these results is 0.2, a value considerably lower than that obtained by most of the previous investigators. Although the quantity per liter is extremely small, the total quantity, since we were using 30 liters of sea water, was sufficiently large for accurate measurements. On one test the ionization current was observed for four days, and the electroscope readings in volts less the natural leak followed accurately the decay curve for radium emanation, diminishing to one-half value in approximately 3.85 days.

In order to check the charcoal absorption meth-

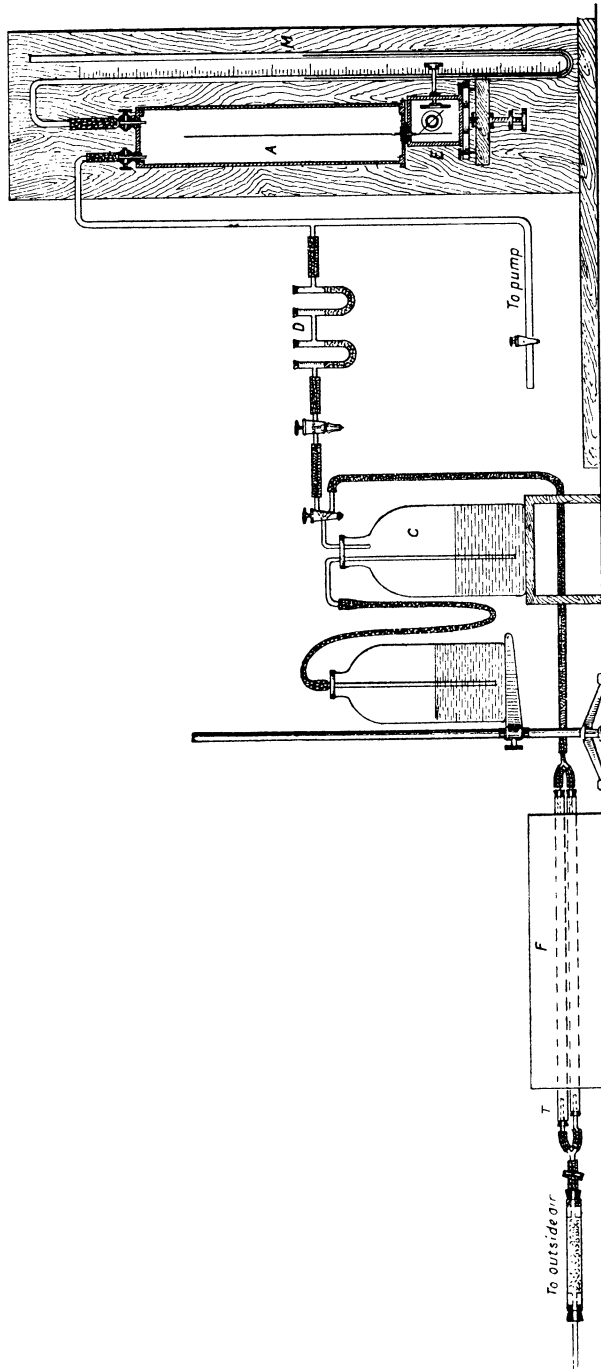

FIG. 2. A, ionization chamber; C, gas collector; D, drying tubes; E, electroscope; F, electric furnace; M, manometer; T, charcoal tubes.

od, one direct test was made on the same sample. Previous to sealing up, the sea water was again acidified with approximately 20 cubic centimeters of pure hydrochloric acid. The method used in this test was, as nearly as possible, a duplication of Joly's, the sample being boiled under a partial vacuum and the flask finally filled with distilled water in order to force all the emanation given off into the aspirator bottle. The determination on the activity of the gas was then made in the usual manner, extreme care being taken to flush thoroughly all the tubes between the aspirator bottle and the ionization chamber.

The value obtained by this method was 0.1, or just half the mean value obtained by the charcoal absorption method. In dealing with large quantities of water, we are inclined to believe that the charcoal absorption method will give the more accurate results. In previous work we found that merely boiling a solution from fifteen to twenty minutes was not sufficient to remove all the emanation from even a weak radium solution, but that bubbling air through the boiling solution was much more effective. For this reason, if no other, the charcoal absorption method ought to be slightly more reliable.

Sufficient data are not at present available to permit the drawing of conclusions regarding the radium content of the oceanic waters of this part of the earth compared to such regions as the northern Atlantic Ocean. But in the light of our results determinations from different parts of the Pacific Ocean are much to be desired.

ILLUSTRATIONS

TEXT FIGURES

FIG. 1. Apparatus used in charcoal absorption method.

2. *A*, ionization chamber; *C*, gas collector; *D*, drying tubes; *E*, electro-scope; *F*, electric furnace; *M*, manometer; *T*, charcoal tubes.

METHODS OF BURNING POTTERY IN THE VICINITY OF MANILA AND THEIR INFLUENCE ON THE QUALITY OF THE PRODUCT¹

By J. C. WITT

(From the Laboratory of General, Inorganic, and Physical Chemistry,
Bureau of Science, Manila)

TWO PLATES AND ONE TEXT FIGURE

Throughout the Philippines there are groups of small establishments for the manufacture of clay products in localities in which the necessary raw materials can be easily obtained. Often brick, tile, and pottery of various sorts are manufactured in the same district. Although the small equipment and limited output of the individual manufacturer is likely to give one the impression that the industry is of relatively small importance, the census report² shows that even fifteen years ago the annual production was valued at 66,499 pesos.³ No recent data are available, but the indications are that the output is increasing.

In the potteries in the vicinity of Manila the principal articles manufactured are flower pots (*pasó*), large jars (*bañga*), often used as containers for water or sugar, round-bottomed bowls for cooking rice (*palayok*), and small wood-stoves (*calan*). The raw materials and processes of this district are similar. A clay from the rice fields and a sand from deposits along Pasig River are used. The clay is spread out, allowed to dry, and then pulverized. The sand is passed through a screen made of split bamboo that corresponds to a laboratory sieve having about 8 meshes per centimeter, and the part retained on the screen is rejected. Two parts of clay and one of sand are mixed, water is added, and the material is kneaded to the desired consistency. Apparently there is no uniformity in the time this mixture is allowed to weather. Often some of it is molded the same day it is prepared, while the remainder is allowed to stand until it is all used.

The molding is accomplished by the aid of very crude potter's

¹ Received for publication May 14, 1917.

² Census of the Philippine Islands. Government Printing Office, Washington (1905), 4, 522.

³ One peso Philippine currency equals 100 centavos, equals 50 cents United States currency.

⁴ Cf. Adams and Pratt, *This Journal*, Sec. A (1910), 5, 143.

wheels. These are usually disks of wood about 50 to 75 centimeters in diameter and 8 to 10 centimeters thick. The wheel is given several revolutions by the feet of the potter and thus acquires sufficient inertia to continue in motion for perhaps thirty seconds. Most of the operators are skillful in the use of these wheels, and much of the ware possesses considerable beauty. The molding of some of the articles is completed on the wheel, but the rice bowls are afterward beaten with a flat wooden paddle. This is done to increase the density for the prevention of leakage and to produce walls as thin as is consistent with the necessary strength. I have often seen these pots with walls less than 0.5 centimeter in thickness, and so uniform that the eye could detect no variation.

When the molding is completed, the pottery is allowed to dry in the shade for several weeks and is then burned by one of two methods:

1. A kiln is employed. There are several types. The commonest is long and horizontal and somewhat cylindrical in shape. Wood is the common fuel. As a rule, high temperatures are not obtained in this type of kiln, because of imperfect construction and the quantity of fuel used. However, in some of them the temperature often exceeds 1,200° C.

2. Much of the pottery, especially the rice bowls, is burned without the use of a kiln. The ware is piled on the ground, even in the street, and is covered with straw, pieces of bamboo, rubbish, and the like. After the fuel is fired, it is allowed to burn slowly until all is consumed. The condition of the ware is observed from time to time through small holes in the straw, and when it has reached a dull red heat, the burning is considered finished. The ash and partly burned fuel are gradually removed, and finally the ware is completely uncovered and allowed to cool. This whole operation usually does not require more than an hour or two.

It is largely imperfect burning that has held back the development of Philippine pottery and has prevented a really well-developed technic (in other respects) from producing ware of excellent quality. From tests made in this laboratory, it is apparent that the raw materials used in the district are of satisfactory quality.⁵ Experiments have also shown that the proportions in which the two substances are mixed are right and that the methods of molding and drying certain kinds of

⁵ See data for clay No. 2, Witt, J. C., *This Journal*, Sec. A (1916), 11, 203.

ware are almost above criticism. However, most of the Philippine ceramic products that I have seen lack strength. This is true of bricks as well as of most pots and jars, and it prevents the manufacture of a really durable product. In the kilns described a few of the articles are burned very well. However, those nearest the fire doors are usually overburned and fuzed out of shape, and many more are not sufficiently burned to develop the maximum strength of the material. The ware manufactured without the use of a kiln is all underburned. This was verified by experiments.

Some of the mixture in daily use at one of the potteries was brought to the laboratory, and several experimental bricks were molded and dried. These were divided into two lots: the first was taken back to the pottery and burned with some ware in the regular way—not in a kiln. A pyrometer was installed, and readings were taken every five minutes during the operation. The other set was burned in an experimental kiln at the Bureau of Science. The temperatures in the latter were determined by Seger cones, because they were too high for the thermocouple.

TABLE I.—*Temperature record of burning in an experimental kiln and in a pile of straw at pottery.*

At pottery.		At pottery.		In experimental kiln.	
Time.	Temperature.	Time.	Temperature.	Time.	Approximate temperature, indicated by cones.
<i>a. m.</i>	°C.	<i>a. m.</i>	°C.	<i>a. m.</i>	°C.
1.45	30	2.40	355	4.00	■ 30
1.50	90	2.45	290	<i>p. m.</i>	
1.55	250	2.50	240	1.00	970
2.00	515	3.00	200	1.20	1,010
2.05	675	3.05	160	1.45	1,050
2.10	745	3.10	130	2.05	1,090
2.15	755	3.15	110	2.25	1,150
2.20	725	3.20	70	3.25	1,190
2.25	665	3.35	60		
2.30	555	3.30	50		
2.35	450				

^a Initial temperature.

The temperature-time curves were plotted and are shown in fig. 1, where the contrast in burning operations is readily seen. At the pottery the burning was completed in one hour and thirty-five minutes. The temperature rose to the maximum point, or over 700°, in thirty minutes, and the first stage of the cooling

was almost as rapid. The curve shows that this system does not conform to established methods of burning pottery, which involve heating the ware gradually until the maximum temperature is reached, maintaining that temperature as nearly constant as possible for some time, and then annealing by slow cooling.

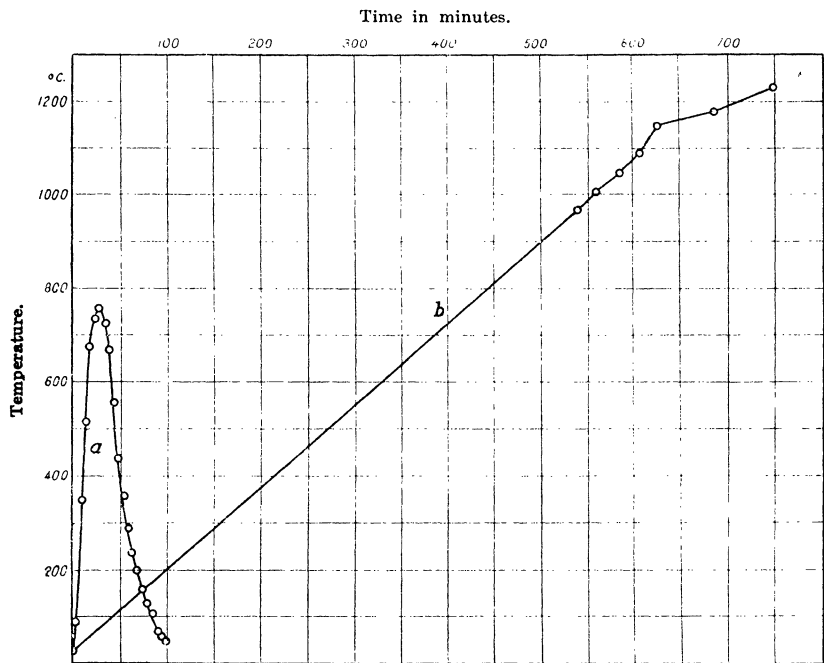

FIG. 1. Rate of burning pottery; a, in pile of straw; b, in experimental kiln.

The bricks burned at each place were tested for compressive strength.

TABLE II.—Compressive strength of test bricks.

Burned at pottery. ^a		Burned in experimental kiln. ^b		
Kilos per square centimeter.	Pounds per square inch.	Approximate temperature. ^c	Kilos per square centimeter.	Pounds per square inch.
		°C.		
252	3,596	1,010	262	3,885
207	2,959	1,050	260	3,709
203	2,896	1,090	261	3,733
223	3,192	1,150	420	5,993
198	2,754	1,190	428	6,118

^a All bricks were removed at end of operation.

^b One brick was removed when each cone fused.

^c Temperatures were determined by Seger cones.

The average compressive strength of the bricks burned at the pottery is 213.6 kilograms per square centimeter, or less than the strength of any one of the specimens burned in the Bureau of Science kiln. While the test at the pottery is a single instance and cannot be regarded as an average, the general procedure of burning is always the same, and it is doubtful if results very much higher than these would be ever obtained.

ILLUSTRATIONS

PLATE I

- FIG. 1. Finishing a calan.
2. Making a palayok.
3. Shaping a bañga on a potter's wheel.

PLATE II.

- FIG. 1. A typical kiln of the Philippines.
2. Burning pottery without the use of a kiln.
3. Pottery on sale in a Manila market.

TEXT FIGURE

- FIG. 1. Rate of burning pottery; *a*, in pile of straw; *b*, in experimental kiln.

154603—2

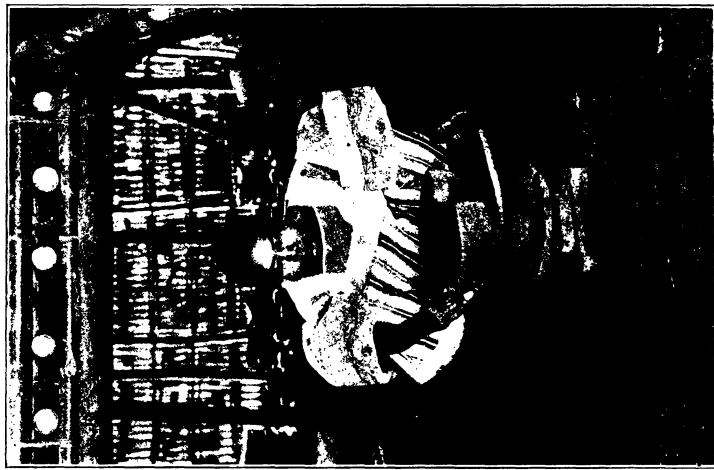

Fig. 1. Finishing a calan.



Fig. 2. Making a palayok.

PLATE I.

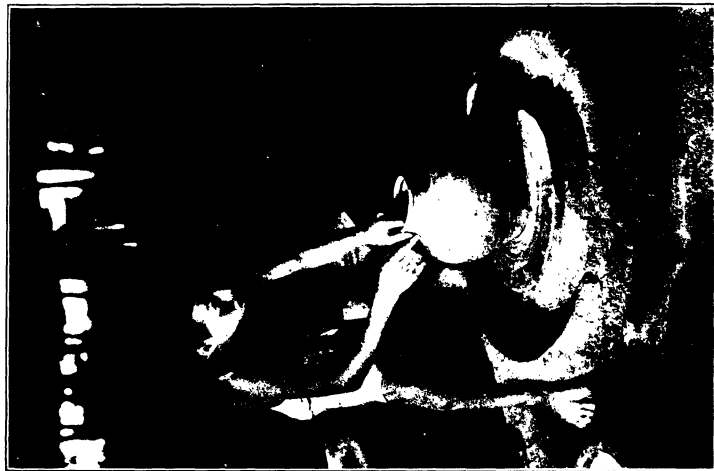

Fig. 3. Shaping a banġa on a potter's wheel.



Fig. 1. A typical kiln of the Philippines.



Fig. 2. Burning pottery without the use of a kiln.



Fig. 3. Pottery on sale in Manila market.

TESTS OF SOME IMPORTED GARDEN LEGUMES

By JOSEPH A. COCANNOUER

(From the College of Agriculture, University of the Philippines, Los Baños)

The legumes taken collectively form a part of the diet of most peoples. Of the very large number of plants belonging to the legume family, there are few that possess greater economic importance than do beans and peas. Besides furnishing nourishing food for men and animals, they provide the agriculturist with a means of securing from the store of nitrogen in the air a sufficient amount of this element to replenish that removed by other crops. For this reason these legumes are not only valuable as food crops, but they are of special value when properly used in a garden rotation.

STANDARD LEGUMES OF THE WORLD

Kidney bean (Phaseolus vulgaris).—According to de Candolle⁽⁵⁾ the kidney bean had its origin in South America. It was unknown in Europe or Asia until the discovery of America. This bean has been excavated from Peruvian tombs in South America and has been found growing wild in several places in the same continent. These are mostly climbing plants, the bush group of *P. vulgaris* having been developed through cultivation and selection. Under each group there are the green and wax pods, but the latter are much less common than the former. The kidneys are the common beans of American and European gardens.

Lima bean (Phaseolus lunatus).—For some time the Lima bean was believed to have had its origin in southern Asia.⁽⁵⁾ De Candolle never considered that there was any foundation for this belief. Like the kidney bean, the Lima has been excavated from Peruvian tombs and has been found wild along the Amazon. According to de Candolle this bean has never been found wild in any part of the Old World.

The Lima is a rank climbing vine and is divided into two very distinct classes:⁽⁴⁾ First, the sieva, which is a slender grower, as compared with the large Lima, and which is comparatively hardy. It is a true annual, producing numerous small papery pods; secondly, the large Lima (var. *macrocarpus*), often called the true Lima, is a tall rank grower, but less hardy than the sieva. The pods are large and fleshy and contain very large flat beans. In the tropics *macrocarpus* is perennial. Bush

types of both classes of Limas have been developed and are rapidly taking the place of the climbing types. These are all annuals.

Lablab or batao (Dolichos lablab).—The history of the lablab is rather obscure.⁽⁵⁾ It is grown extensively in both Asia and Africa, and de Candolle believed that it grew wild in India. The lablab is cultivated more in southern Asia than perhaps any other legume. The batao is one of the commonest legumes in the Philippines and is found both cultivated and “in a wild state.”⁽⁸⁾

The lablab is a glabrous, twining vine whose stems are often purplish. The flowers may be pink, purple, or nearly white. The pods are oblong, wide, and flattened and may be reddish purple, dark green, or white. There are several types,⁽⁷⁾ most of the differences occurring in the color and size of the pods.

Cowpea or paayap [Vigna cylindrica (V. unguiculata, V. catjang)].—While the cowpea is not a true bean, it may be classed with the latter because of the close relationship. It is a native of India⁽²⁾ and was introduced into America during the latter half of the seventeenth century. In India the cowpea is a rank-growing vine, but in Europe and America the bush types are practically the only ones grown.

The cowpea is readily recognized by its long, slender, cylindrical pods. These are usually pale green, but one (*V. sinensis*) produces red pods.

While the cowpea is a coarse legume, it is usually productive, and the young, tender pods are very palatable if properly prepared. The points in favor of the *Vigna* group are their hardiness and ability to produce a remunerative crop in almost any type of soil.

Sword bean (Canavalia gladiata).—Though the sword bean is not a native of the Philippines, four species of the genus, according to Merrill, occur here; *Canavalia gladiata* is the only one considered to be a food legume. MacMillan⁽⁷⁾ quotes Fir-minger as stating that the sword bean is considered by some Europeans to be the “nicest of native vegetables in India.”

The edible sword bean (*Canavalia gladiata*) is a climbing vine with very large leaves and flowers. The pods are long, broad, and flat, and each contains several large red beans. The pods are used when young and tender, being cut into slices and used as a vegetable. This bean is supposed to have been described first from Brazil, though there are many species scattered throughout the tropics of the world.

Winged bean or calamismis (Psophocarpus tetragonolobus).—The winged bean, according to MacMillan, is a native of Malaysia. It is a glabrous twining vine with light blue flowers. Its pods are square and 4-winged. The crisp, tender pods when properly prepared make one of the best vegetables found in the Philippines. This legume readily produces 150 well-formed pods per plant. The calamismis produces a tuberous root, which is very palatable. In Burma these beans are grown almost entirely for their roots, which yield 2.5 to 4.5 tons per hectare. (7)

Broad bean (Vicia faba).—The broad bean is one of the oldest known members of the bean family. It is a native of the Old World, (5) the exact spot of its origin still being questionable. This bean does well only in very cool climates and, so far as I am aware, has never been found a satisfactory legume for tropical gardens. The pods are long and broad, each containing from seven to nine large beans. The broad beans belong to the bush type.

Mungo [Phaseolus aureus (P. mungo)].—The mungo is a native of India (7) and has been cultivated there as one of the leading food crops as far back as history goes. It is an erect "history" must be a lobster plant and produces narrow, straight, cylindrical pods averaging from 5 to 6 centimeters in length. The entire plant, including the pods, is covered with hairs.

The mungo is common in the Philippines, being one of the crops that can be grown during the time of the year when it is too dry for most other crops. The young pods are sometimes used for food, but it is the dry bean that is especially prized. The beans are prepared as a vegetable in various ways and are very palatable.

Chick pea (Cicer arietinum).—The chick pea is an annual plant about 30 centimeters high. The seeds are pealike and angular. This is a common legume in southern Europe and is grown to some extent in India and Ceylon. (7) The chick pea is a favorite legume for use with other vegetables, and in some localities it is very popular, being served in curries.

Pigeon pea (Cajanus cajan).—The pigeon pea is a shrub from 1.5 to 2 meters high. It is a native of India, (3) but is now cultivated in most tropical countries. The pods are small and semiflat. Each contains from 2 to 4 smooth, spherical peas. The dry peas are excellent when served as a vegetable or when used in soups and curries.

Garden pea (Pisum sativum).—The garden pea, according to de Candolle, is a native of the Old World. It has never been

found in a wild state, and there is considerable disagreement as to whether this pea has been developed from the field pea (*Pisum arvense*) or was distinct in nature. It is believed that the garden pea first existed in a wild state between the Caucasus and Persia. The Aryans are supposed to have first introduced it into Europe.

Garden peas are divided into two very distinct types: the wrinkled and smooth-seeded. The latter are hardier than the former, but on the other hand are considered much inferior in flavor. There are tall and dwarf varieties under each type, the former usually being much later than the latter.

The pea is distinctly a cool-season crop and it is grown extensively in northern Europe and America. However, in India the pea has been acclimatized, until good crops are now secured in that country.

Lentil or lens (Ervum lens).—The lentil is the standard legume of both Palestine and Egypt. It is also a leading crop in India during the cool months.⁽⁶⁾ The Hindoos consider the lentil the "most nutritious of pulses." The plant is a much-branched, tufted annual, ranging from 30 to 50 centimeters in height. The pods are short, broad, and very flat and contain two flat seeds. The seeds are rounded and convex on both sides. The ancient astronomers named them "telescope glasses," i. e., lenses, because they were shaped like the seeds of *Ervum lens*. The dry seeds are eaten.

Soy bean [Glycine max (G. hispida)].—The soy bean is a native of China and Japan.⁽⁵⁾ It is an erect annual varying from 50 to 100 centimeters or more in height. The pods are short and hairy and contain from 2 to 4 pealike seeds. The seeds vary in color from white to black. These are prepared for food in various ways, being roasted, ground into flour, or boiled. The soy bean contains little or no starch.

Velvet bean (Mucuna nivea).—The velvet bean is a strong climber that produces clusters of hairy pods about 6 centimeters long and 1.25 centimeters in diameter. This bean is grown extensively in China, where it probably originated. The pods are either green or black and contain beans that correspond to the pods in color. Each seed is covered by a tough coat, which must be removed before the beans are edible. In China the beans are used extensively for food, and in India both the beans and the young pods are eaten.

Of the fourteen species of legumes discussed, a goodly number are now successfully grown in the Philippines on a commercial scale. These are the Lima, the lablab, the cowpea, the winged

bean, the mungo, and the pigeon pea. Others have been introduced during late years and are now established in a few parts of the Islands. These are the garden pea, the velvet bean, the soy bean, the sword bean, and the kidney bean. The broad bean has received little consideration in the Philippine tropics, but has been given severe tests in other tropics of the world, and so far as I have been able to learn has never been found a success. The lentil also has received little attention in the Philippines, although it is a standard legume in certain other tropical countries. The chick pea is imported into the Philippines in rather large quantities, and several efforts have been made to produce it here, but with little success. While I was in charge of the farm school at Indang, Cavite Province, I made several attempts to grow chick peas, but was never able to secure any crop whatever. The plants grew vigorously and in some cases blossomed freely, but no seed ever developed.

Garden peas are now grown extensively in some localities of the Philippines, and they give promise of soon becoming one of the leading products in several sections. Kidney beans of an excellent quality are also slowly but surely making their way into the local markets. These, too, promise to be extensively propagated on a commercial scale soon. Just how these beans and peas were first introduced is not known. The peas were probably brought in by Chinese market gardeners, and the beans very likely came through the schools.

Of the numerous legume projects carried on by the College of Agriculture during past years, the work with soy beans will probably stand out as being the most valuable. A legume that previously had been considered impossible of culture in the Philippines has been developed through careful study and selection, until it ranks among the most productive legumes grown on the college farm. Other legumes, such as the cowpea, the mungo, and several varieties of Limas, have received special study, and in some cases very encouraging results have been secured.

OBJECT OF THESE EXPERIMENTS

The object of these experiments was twofold: First, to test several varieties of *Phaseolus vulgaris*, *Phaseolus lunatus*, and *Pisum sativum*, which are ranked as "leaders" by American market gardeners, in order to find out whether a profitable yield could be secured from these legumes in the Philippines under ordinary garden conditions and what season or seasons of the year were best suited to their production; secondly, to secure seed for pedigree-selection work with the view of establishing

some of the most promising varieties as garden legumes in the Philippines.

TABLE I.—List of varieties.

Variety.	Species.	Group.	Type.	Collection No.
Beans:				
Black Valentine	<i>Phaseolus vulgaris</i>	Bush	Green pod	4700
Long Yellow Six Weeks.dododo	4687
Mexican Pinkdododo	4938
Longfellowdododo	4695
Extra Early Refugeedododo	4701
Canadian Wonderdododo	4948
French Mohawkdododo	4946
Dwarf Horticulturaldododo	4696
Extra Early Red Valentine.dododo	4697
Hodson's Green Poddododo	4570
Teparydododo	4945
Michigan White Waxdodo	Wax pod	4571
Prolific Black Waxdododo	4937
Southern Creasebackdo	Climbing	Green pod	4952
Kentucky Wonderdododo	4685
Lady Washingtondododo	4953
Southern Prolificdododo	4769
Henderson's Bush Lima.	<i>Phaseolus lunatus</i>	Bush	Sieva	4956
Challenger Limado	Climbing	Potato	4957
King of the Gardendodo	Macrocarpus	4960
Peas:				
Advancer	<i>Pisum sativum</i>	Semidwarf	Half-late	6154
Stratagemdododo	6156
Mott's Excelsiordo	Dwarf	Early	6161
Senatordo	Tall	Late	6162
Little Gemdo	Dwarf	Early	6164
Blue Bantamdododo	6159
British Wonderdo	Tall	Late	6364
Yorkshiredo	Semidwarf	Half-late	6157
Extra Earlydo	Medium-tall	Early	6152
Laxtoniado	Semidwarfdo	6357
Alaskado	Talldo	6361
Prosperitydodo	Half-late	6353- <i>a</i>
American Wonderdo	Semidwarf	Early	6153
Little Marveldo	Dwarfdo	6158
Laxtondo	Talldo	6149
Aldermandodo	Late	6354
Abundancedo	Semidwarf	Half-late	6150
Telephonedo	Tall	Late	6151
Champion of Englanddododo	6360
Large White Marrow-fat.do	Very talldo	6355
Horsford's Market Garden.do	Tall	Half-late	6353

All plantings were carried on as projects. The year was divided into three seasons, namely, the cool, which includes October, November, December, and January; the dry season, which includes February, March, April, and part of May; and the wet season, which usually begins about the middle of May and includes June, July, August, and September. Naturally no keen line of demarkation can be drawn between the three seasons, but they are sufficiently well marked as to have distinctly different effects upon plant growth.

PROJECT 1. COOL SEASON

Project 1 was started early in November, 1915. Owing to weather conditions during November, it was not possible to make all of the plantings on the same day. The extremely heavy rains made the replanting of most varieties necessary, and many had to be replanted the second time. However, climatic conditions were so nearly the same during November and part of December, 1915, that the variance in the planting dates probably had little effect on the ultimate results.

The soil on which all of the beans were planted was a heavy clay loam underlaid with a stiff adobe subsoil. The surface soil ranged from 30 to 70 centimeters deep, and owing to the prevalence of cementing materials, it had to be continually stirred to prevent baking. No crop was grown on the land during the previous rainy season. The soil was dug up with the spading fork and then worked into a mellow consistency with the hoe and rake. All plats were 5 by 10 meters, with a 30-centimeter path between the plats. The seeds were planted in rows 70 centimeters apart, and the plants stood 50 centimeters apart, with one plant in the hill, excepting the large Limas, which were planted 1 meter each way. Cultivations were given two or three times each week during the entire growing period.

Table II shows the varieties in order of their rank, which were considered worthy at the first harvest.

TABLE II.—Varieties, in order of rank, considered worthy of the first harvest.

Variety. ^a	Rank.	Average pods.	Weight of edible food per plant.	Days from planting till serviceable.	How used.
			Grams.	Days.	
Southern Prolific	1	23	146	54	Green.
Henderson's Bush Lima	2	13	21	66	Shell.
Kentucky Wonder	3	20	132	54	Green.
Tepary	4	51	8	61	Dry.
Mexican Pink	5	17	97	53	Green.
Canadian Wonder	6	14	91	40	Do.
Lady Washington	7	15	87	42	Do.
Michigan White Wax	8	20	134	38	Do.
Prolific Black Wax	9	21	140	38	Do.
Southern Creaseback	10	19	118	54	Do.
Extra Early Valentine	11	14	80	40	Do.
Long Yellow Six Weeks	12	7	44	48	Do.
Hodson's Green Pod	13	4	33	69	Do.
Extra Early Refugee	14	5	38	42	Do.

^a The Black Valentine, the Longfellow, the French Mohawk, the Dwarf Horticultural, the Challenger Lima, and the King of the Garden Lima were almost complete failures. A very few seeds were saved with which to continue the varieties in later projects.

SUMMARY OF PROJECT 1

1. The experiment showed that most of the kidney beans will give a fair yield if the plantings are made during the cool season. With the exception of the last three varieties listed in the table above, the yields were practically equal to what is ordinarily secured from the same varieties in the United States.

2. In some cases there was a marked lessening of the ordinary time from planting until a serviceable product could be secured, while with other varieties the time was not materially changed.

3. Some varieties proved themselves entirely unable to resist the attacks of the leaf hopper and the bean maggot. Some started out vigorously, but soon began to show signs of weakness. A few varieties showed almost no effect of climatic conditions. The varieties of *Phaseolus lunatus* were entirely resistant to the bean maggot and leaf hopper.

PROJECT 2. HOT SEASON

The plantings of the second project were made in the college gardens during March, 1916. The object of this project was to discover what results could be secured by growing beans during the dry season under irrigation. F₁ seed from all of the original varieties was used, and the soil was worked into a "quick" condition as was done in project 1. The seed germinated well, and

when the plants first appeared above ground, they were especially promising.

After about the third day very marked changes could be seen taking place in all of the varieties of *Phaseolus vulgaris*. There was a general yellowing of the leaves, and the small hopper perforated them until they appeared like sieves. The ravages of these insects were materially checked by spraying with a very weak solution of kerosene emulsion. It seemed for a while as if a partial harvest might be secured, but the leaf hopper was no sooner checked than the beans began to show the signs of the bean maggot. Isolated plants died here and there, and within a few days every plant had succumbed. A very special effort was made to save even a few plants of the most promising varieties, but the plats planted to the kidney beans were wiped absolutely bare, and not a seed was saved.

An experiment similar to this was carried on by me at the farm school at Indang, Cavite Province, during the hot months of 1913. The same pests were almost as prominent, and although partial crops were secured, there did not result a profitable yield.

The varieties of *P. lunatus* planted in project 2 were entirely resistant to both the leaf hopper and the bean maggot. The plants grew well from the outset and blossomed freely. There were at first promises of a satisfactory production, but the old habit of shooting the pods was evident as soon as the latter began to appear. The vines grew vigorously during the entire hot season and until they were finally removed in June. Almost no pods reached maturity.

This experiment showed that the growing of kidney beans during the dry season under irrigation is not practicable in this locality.

PROJECT 3. DRY SEASON

Project 3 was carried on in my home garden. Two plats were laid off, each 10 meters wide and of sufficient length to contain twelve varieties of beans, allowing one variety to each row. A 1-meter patch separated the two plats. The land was new and was worked into a mellow consistency by means of spading fork, hoe, and rake. F_1 seed of the following varieties of beans was planted: Tepary, Kentucky Wonder, Canadian Wonder, Henderson's Bush Lima, Mexican Pink, Southern Prolific, French Mohawk, Long Yellow Six Weeks, Prolific Black Wax, Hodson's Green Pod, Michigan White Wax, and Longfellow.

Plat A.—This plat was planted March 11, 1916. The rows

were 50 centimeters apart, and the distance between the hills was 40 centimeters. Two or three seeds were planted in a hill, and when the young plants were well established, they were thinned out so as to leave only one plant in a hill. When the plants were about 5 centimeters high, the plat was covered with a heavy mulch of grass. The mulch was well tamped down with the feet, and special care was taken to see that the grass fitted snugly around the bases of the plants. The mulch was not removed during the entire life of the plants, and naturally the plat was not cultivated after the mulch was put on.

Plat B.—This plat differed from A in that no mulch was used and that the plants received a good cultivation once each week by the hoe. The plants were not irrigated.

Some very interesting facts were brought out in project 3, as the tables will show. Most of the varieties gave a far greater yield in the plat that was mulched than in the unmulched plat. However, it will be noted that a few varieties did not respond with a satisfactory yield in either case. The Limas were severely attacked by the blight and did not mature any pods, although they blossomed profusely.

Perhaps the most noticeable feature connected with project 3 was the great difference between the fruiting seasons of the plants in the two plats. Most of the mulched plants were green and fresh for some time after the plants in the other plat had dried up. Light showers frequently occurred after the plants were fruiting, and these revived those in the unmulched plat, so that they gave a fair, late yield.

There was almost no difference in the sizes of the pods produced in the two plats, and after the weighing of a definite number of pods taken at random, it was necessary to conclude that the mulch increased the number of pods rather than the size.

Neither the bean maggot nor the leaf hopper gave much trouble in project 3, which was radically different from what happened to project 2, which was planted at about the same time. It is believed that this was due rather to the rapidity with which the plants grew than to the absence of the insects. The soil was rich in nitrogen, which soon forced the plants beyond the danger of the pests.

TABLE III.—Showing effect on plants when plat was covered with a heavy mulch of grass.

Variety.	Planted.	Flowered.	Served.	Mature.	Average pods.	Maximum pods.	Fifty green pods.	One hundred ripe beans.	Rank.
Tepary	March 11	April 9		May 6	44	74		16	9
Kentucky Wonder	do	April 17	April 29	May 20	28	60	440	37	2
Canadian Wonder	do	April 9	April 22	May 13	14	21	340	65	6
Henderson's Bush Lima	do	April 10	(*)						
Mexican Pink	do	April 5	April 26	May 5	23	38	267	32	4
Southern Prolific	do	April 16	April 27	May 14	139	206	330	38	1
French Mohawk	do	April 7	April 19	May 13	7	11	(?)	45	0
Long Yellow Six Weeks	do	April 5	April 22	May 14	16	36	327	33	5
Prolific Black Wax	do	April 7	April 15	May 12	11	24	280	34	8
Hodson's Green Pod	do	April 16	May 25	June 14	5	8	456	24	
Michigan White Wax	do	April 4	April 15	May 7	17	43	336	35	3
Longfellow	do	April 10	April 22	May 11	15	37	320	26	7

* Completely destroyed by blight.

TABLE IV.—*Showing growth of plants when no much was used.*

Variety.	Planted.	Flowered.	Served.	Mature.	Average pods.	Maximum pods.	Fifty green pods.	One hundred ripe beans.	Rank.
							Grams.	Grams.	
Tepary	March 20	April 14		May 11	37	101	14	14	9
Kentucky Wonder	do	April 17	May 10	June 4	9	20	440	36	5
Canadian Wonder	do	April 20	May 5	June 4	7	8	340	46	8
Henderson's Bush Lima	do	(*)							0
Mexican Pink	do	April 16	April 28	May 21	7	11	287	23	7
Southern Prolific	do	do	May 14	June 22	98	162	330	28	1
French Mohawk	do	April 19	May 8	June 3	5	11	(?)	45	0
Long Yellow Six Weeks	March 22	April 22	May 16	June 5	16	32	327	35	2
Prolific Black Wax	do	do	May 18	June 7	14	27	280	33	4
Hodson Green Pod	do	May 3	May 26	June 8	3	5	456	(3)	0
Michigan White Wax	do	April 20	May 10	June 6	16	27	336	29	3
Longfellow	do	April 23	May 21	June 7	8	17	320	22	6

* Completely destroyed by blight.

SUBPROJECT 1. DRY SEASON

At the time of planting of project 3 a subproject was run, which consisted of the planting of 150 square meters of Tepary beans. The plat was located in the college gardens and was prepared by means of spading fork, rake, and hoe. The rows were 70 centimeters apart, and the hills stood 50 centimeters apart with two plants in a hill. The entire plat was cultivated regularly once each week.

The object of subproject 1 was to find out just what production could be secured from Tepary beans grown on a commercial scale during the time when there is little or no rain. The records kept were only those directly related to yield. Promising individual plants were marked, and a careful record was made of the individual production of each of these.

The results secured from this project were very interesting. The plants remained green and continued to produce when even the native beans were suffering for water. No doubt by working with selected individuals the yield of these beans can be very materially increased and the Tepary established as a very valuable dry-weather bean for the Philippines. Experiment has shown that the plants will shoot practically all of their pods during the rainy season, and those that do hang on mature almost no seed.

Very special precautions must be taken in carrying the Tepary beans over from one season to another. Even the slightest moisture will readily cause the beans to lose their vitality. The Tepary is distinctly a dry-weather legume, and the seeds should be dried and sealed during the dry months before the rains begin.

TABLE V.—Showing the number of pods and the weight of ripe beans secured in subproject.*

Plant No.	Pods.	Ripe beans.	Plant No.	Pods.	Ripe beans.	Plant No.	Pods.	Ripe beans.	Plant No.	Pods.	Ripe beans.
		<i>Grams.</i>			<i>Grams.</i>			<i>Grams.</i>			<i>Grams.</i>
1	27	12.45	6	24	15.11	11	23	11.04	16	25	10.80
2	25	11.26	7	23	11.12	12	29	12.68	17	36	18.62
3	25	10.79	8	26	11.00	13	27	10.03	18	25	11.20
4	28	10.09	9	22	10.07	14	33	15.34	19	31	13.00
5	27	11.04	10	24	12.24	15	21	11.16	20	28	9.93

* These yields are about two-thirds of what are secured from the Tepary in southern California.

PROJECT 4. WET SEASON

Project 4 consisted of the plantings of sixteen varieties of beans in the college gardens in a plat 15 meters wide and of

sufficient length to contain all of the varieties. The rows were 70 centimeters apart, and the hills stood 50 centimeters apart with two plants in a hill. The soil was first plowed and then worked into a mellow consistency by means of hoe and rake. The plants were cultivated regularly twice each week. The plantings were made on May 11, 1916, and there was sufficient rain so that irrigation was not necessary. F_1 seed secured from the first plantings was used.

The results obtained from project 4 were disappointing. Only six of the sixteen varieties of beans matured any seed whatever. Neither the Tepary nor the Henderson's Bush Lima produced any pods. Both of these varieties shot their pods when young, because of fungus attacks.

Practically all of the varieties of *P. vulgaris* were severely attacked by the bacterial disease caused by *Pseudomonas phaseoli*. The pole varieties were much more resistant, and a few seeds were saved from a few of those that were apparently free from the disease. It was not possible, however, to save any mature seed from any of the bush varieties. The Hodson's Green Pod, the Longfellow, the Extra Early Refugee, and the Lady Washington all failed because of the attacks from the bean maggot.

The yields were in all cases much below what would be a satisfactory garden production. The Kentucky Wonder, the Canadian Wonder, and the Southern Creaseback gave mediocre yields, but the Southern Prolific came near failing entirely. In most cases there was a slight decrease in the size of pods and in some cases in the size of the ripe bean.

PROJECT 5. WET SEASON

Project 5 consisted of the plantings of fifteen varieties of beans in my home garden, all being *Phaseolus vulgaris*. One row was given to each variety, the rows being 10 meters in length. The rows stood 50 centimeters apart, and the hills were 40 centimeters apart with one plant in a hill. All varieties except two were planted on May 8, 1916, the two exceptions being planted on May 21. F_1 seed secured from the first plantings was used.

Every variety experimented with project 5 started out very promisingly. The bean maggot gave very little trouble, and even with a bacterial disease severely attacking every variety, each gave a fair yield. The disease attacked the pods of all varieties to such an extent that it was practically impossible to secure any ripe seeds whatever.

TABLE VI.—Data of project 5.^a

Variety.	Planted.	Flow- ered.	Served.	Mature.	Maxi- mum pods.	Aver- age pods.	Rank.
Kentucky Wonder	May 8	June 17	June 28	July 14	15	9	0
French Mohawk	do	June 7	June 21	July 15	23	12	8
Extra Early Refugee	do	June 5	June 18	July 13	26	19	8
Extra Early Valentine	do	June 6	June 15	July 12	44	15	6
Hodson's Green Pod	do	June 9	June 20	July 14	28	23	0
Canadian Wonder	do	June 6	June 18	July 13	26	19	4
Mexican Pink	do	June 5	June 17	July 12	23	12	7
Lady Washington	do	June 6	June 19	July 11	34	23	1
Dwarf Horticultural	do	do	June 18	July 14	29	16	5
Tepary	do	June 2	(b)				
Southern Prolific	do	June 19	June 30	July 18	41	21	2
Michigan White Wax	May 21	June 17	June 24	July 20	26	9	9
Longfellow	do	June 19	July 1	July 15	8	4	0

^a In ranking the different varieties in project 5, the weight of pods was not recorded because there was still no noticeable change in their size. In the tabulations of the data for this project no weights were recorded, also for this same reason. The amount of edible food material produced for each variety in the different projects will vary as the number of pods.

^b Plants shot their pods owing to rain.

Table VII aims to show the results from the first plantings made during each of the three seasons: the cool, the hot and dry, and the wet. The original plantings were made during the cool months, and the results secured from these plantings are shown in the first columns. The plantings made during the dry and wet seasons were duplicated, one series being run in the college gardens and one series in my home garden. The dry season plantings in the college gardens were irrigated and cultivated regularly, while those run in the home garden were not cultivated nor irrigated, but were thickly mulched with dry cogon grass. As is shown in the table, the results secured from the mulched cultures for nearly all of the varieties were exceptionally good, while the irrigated crops were a complete failure. Of course, there were features other than heat or moisture that entered in to cause the great difference in the results secured. The soil in the home garden was richer, and although the bean maggot and leaf hopper were present, they were not so numerous as in the college gardens. But notwithstanding these factors, there is a very decided balance on the side of the mulch. The soil is always kept cool and moist, irrespective of how high the temperature above the ground may be. A cool soil is a very essential factor in growing crops during the hot season, and this is not always possible where irrigation is used.

TABLE VII.—Summary of first planting of beans.

[0, failure; blank space indicates not run.]

Variety.	Original planting.				Plantings of F ₁ seed in college gardens.				Plantings of F ₁ seed in home gardens.						
	November, December, January.		February, March, April, May (irrigated).		June, July, August.		March, April, May (mulched).		June, July, August.		Days till service-able.				
	Rank	Average pods.	Days till service-able.	Rank	Average pods.	Days till service-able.	Rank	Average pods.	Days till service-able.	Rank	Average pods.	Days till service-able.			
Southern Prolific.....	1	23	54	0	0	0	3	14	67	1	139	57	2	21	53
Henderson Bush Lima.....	2	13	66	0	0	0	0	0	0	0	0	0	0	0	0
Kentucky Wonder.....	3	20	54	0	0	0	2	16	64	2	28	59	2	9	51
Tepary.....	4	51	61	0	0	0	0	0	0	0	44	56	0	0	0
Mexican Pink.....	5	17	53	0	0	0	0	0	0	0	9	44	4	0	0
Canadian Wonder.....	6	14	40	0	0	0	4	14	48	6	14	42	5	19	41
Lady Washington.....	7	15	42	0	0	0	0	0	0	0	0	0	1	23	42
Michigan White Wax.....	8	20	38	0	0	0	6	5	47	3	17	35	9	9	34
Prolific Black Wax.....	9	21	38	0	0	0	5	6	48	8	11	35	0	0	0
Southern Creaseback.....	10	19	54	0	0	0	1	17	65	0	0	0	0	0	0
Extra Early Valentine.....	11	14	40	0	0	0	0	0	0	0	0	0	6	15	38
Long Yellow Six Weeks.....	12	7	48	0	0	0	0	4	48	5	16	42	0	0	0
Hodson's Green Pod.....	13	4	69	0	0	0	0	0	0	0	0	0	0	8	43
Extra Early Refugee.....	14	5	42	0	0	0	0	0	0	0	0	0	3	19	41
Dwarf Horticultural.....	15	7	40	0	0	0	0	4	51	0	0	0	5	16	41
Longfellow.....	0	5	46	0	0	0	0	0	0	7	15	42	0	4	53
French Mohawk.....	(a)	(a)	(a)	0	0	0	0	4	48	0	7	39	8	12	44
Black Valentine.....	0	6	45	0	0	0	0	0	0	0	0	0	4	18	51
King of the Garden.....	(b)	(b)	(b)	0	0	0	0	0	0	0	0	0	0	0	0
Challenger Lima.....	(b)	(b)	(b)	0	0	0	0	0	0	0	0	0	0	0	0

* Almost worthless; few seeds saved.

b Very few seeds saved.

Perhaps the strongest point brought out in all of the plantings recorded in this table is the great fluctuation in length of time from planting until the product becomes serviceable for food. Various reasons have been assigned for this. With the plantings made the latter part of May in the college gardens the number of days from planting till serviceable was very materially lengthened for nearly all varieties. This is believed to be due to the fact that after the few light showers in May there was a dry period in June sufficient to check the growth of the plants just before they began to flower. The plants remained in a seemingly dormant condition for several days, when on the arrival of the heavier showers they started into vigorous growth again. While ordinarily dry weather has a tendency to hasten maturity, it seems that in this case a general rule has been broken. It is possible that some other reason may exist, but I have been unable to discover it.

Occasionally the plants will shoot all of the first flowers either because of excessive moisture or disease, and this will materially lengthen the time until the first pods become serviceable.

PROJECT 6-A. WET SEASON

In project 6-A an effort was made to grow the two leading pole varieties of kidney beans, the Kentucky Wonder and the Southern Prolific, in a large plat on a market-garden scale. The soil was first plowed and then worked into a mellow condition by means of hoe and rake. F_1 seed from the original plantings was used, and the hills stood 50 by 70 centimeters apart with two plants in a hill. The plan was to cultivate the plat once each week with the garden cultivator, but the rains were often too severe to permit this.

While the plants in this project started fairly well, much replanting was necessary owing to the bean maggot and other causes, and the final outcome was that not more than 5 per cent of the plants reached the podding stage. Scattered plants here and there gave a fair production, but nothing approaching what would be considered a market-garden yield.

PROJECT 6-B. WET AND COOL SEASONS

Project 6-B consisted of 25 square meters of Kentucky Wonder pole beans planted in the college gardens. F_2 seed harvested from project 3 was used, and the planting was made on August 25, 1916.

The object of this project was to give the Kentucky Wonder a severe test during the time when the rains were heavy. The

soil was prepared as well as practicable under existing conditions, but it was not possible to work it into a mellow state before planting, owing to the excessive moisture. The plat received little cultivation other than keeping down the weeds.

This planting gave rather unexpected results. The average number of pods produced per plant was fifteen, which is low for this variety; yet taking into account the heavy rains and the small amount of cultivation that it was possible to give, the results were satisfactory.

At the same time that this project was run there was also planted a plat each of the Southern Prolific and Southern Creaseback pole beans, but both of these varieties were unable to endure the severe weather conditions and finally succumbed without giving any production whatever.

PROJECT 6-C. COOL SEASON

Project 6-C consisted of a large plat each of the Southern Prolific and Lady Washington pole beans and a small plat of the Long Yellow Six Weeks bush beans, the first two varieties planted on September 2, and the last planted on September 9, 1916. F₂ seed was used, and the hills stood 50 by 70 centimeters apart with one plant in the hill.

The plat of Southern Prolific was more promising at the outset than any planting of this variety previously made. The plants were very uniform, and very few of them succumbed to the ravages of the bean maggot. The vines were strong and vigorous until podding time, when they began to show signs of weakness. What at first promised to be a good production turned out to be a very mediocre one. The plants ceased blossoming after producing the first pods. The maximum number of pods secured from any one plant was twelve with an average per plant of eight pods. This yield was very disappointing and much below what would be expected of this variety.

The Lady Washingtons were much inferior to the Southern Prolifics. A few of the plants struggled along and produced a few green pods, but a bacterial disease caused all of these to drop before maturity, no ripe beans whatever being saved. In some cases the plants died while still producing flowers and pods for no apparent reason. The Lady Washington might be well considered a complete failure in this project.

The Long Yellow Six Weeks did surprisingly well. The plants grew vigorously and gave a fair production. While the number of pods produced was below what would be considered a good yield, yet for this season it could not be considered unsatisfactory.

The maximum number of pods secured from any one plant was eleven, with an average of seven for each plant.

TABLE VIII.—Data for project 6-C.

Variety.	Planted.	Flow- ered.	Service- able.	Maturity.	Average pods per plant.	Maxi- mum pods per plant.
Southern Prolific.....	Sept. 2	Oct. 2	Oct. 22	Nov. 10	8	12
Lady Washington.....	do	Oct. 6	Oct. 16	(*)		
Long Yellow Six Weeks.....	Sept. 9	Oct. 7	Oct. 20	Nov. 13	7	11

* No harvest secured.

PROJECT 6-D. COOL SEASON

Project 6-D consisted of an area of the Henderson's Bush Lima 5 by 7 meters, planted in my home garden on September 2, 1916. F₁ seed from the original planting was used. There was little trouble from the bacterial disease, and even the lightest bearing plants gave a good yield of pods. The maximum number of pods produced on any one plant was forty-two, with an average production of thirty-five pods for each plant. The experiment shows that this is a good bean for this locality, providing it is grown during the cool season. The Henderson's Bush is an early Lima, and even a small area will give a satisfactory production with ordinary care. The yield secured from this variety was practically the same as that secured under ordinary conditions in the United States.

PROJECT 6-E. COOL SEASON

Project 6-E was one of the most satisfactory of the entire set of experiments.

It consisted of the planting of a plat each of the Challenger Pole Lima and the King of the Garden, the latter also a large Lima of the pole type. Both of these plats were planted on August 16, 1916. The King of the Garden became serviceable on November 21, and the Challenger on November 23.

The results of this project were a great contrast to what were secured from the original plantings. All of the plants made a vigorous growth and seemed to adapt themselves to conditions almost as well as the local varieties, which were growing near by. Most of the flowers produced pods that were well filled with large beans conforming in both size and shape to the original seed.

It was not possible to secure an exact production record from either of these plats owing to the fact that the hills and rows stood the same distance apart as is common with such Limas in the United States, and consequently the vines intertwined so

that it was not practicable to count the pods on individual plants. The experiment showed conclusively that the distance between individual plants in the tropics should not be less than 1.25 meters each way.

The King of the Garden proved to be a better yielder than the Challenger. The pods ranged from 10 to 12 centimeters in length and from 2 to 2.5 centimeters in width. Practically every pod contained four large uniform white beans, 2 centimeters wide, 2.25 centimeters long, and about 0.625 (five-eighths) centimeter thick. The pods of the Challenger ranged about 8 centimeters in length and 2.5 centimeters in width, but the bean was considerably thicker than that of the King of the Garden.

Nothing could be more discouraging than these Limas were in the previous plantings. The few seeds that it was possible to save at the first harvest brought forth very unexpected results, and the general condition of the plants left little doubt that both Limas were able to adapt themselves to tropical conditions.

PROJECT 7. COOL SEASON

Project 7 consisted of the plantings of all of the varieties of kidney beans grown at the first planting, excepting those that were run in special projects. F_1 seed secured from the first harvest was used, and all the plantings were made from October 15 to November 6, 1916. This season was very much the same as that of October, November, and December, 1915, the time when the first plantings were made.

Project 7 was run in my home garden rather than in the college gardens for the reason that the soil in the home garden is much richer and mellower than that in any of the college gardens. It was considered essential to give the F_1 seed every opportunity to show what it could do by being planted at exactly the same season as were the original plantings. Those seeds that proved themselves too weak to come through with the best possible care could be hardly expected to withstand a severer treatment.

Unfortunately most of the varieties proved to be weaklings from the beginning, and some of them were very disappointing. Something was expected of the Extra Early Refugee and the Long Yellow Six Weeks, yet they proved themselves unable to endure the slightest adverse conditions. The French Mohawk, the Dwarf Horticultural, the Extra Early Red Valentine, the Hodson's Green Pod, and the Longfellow did not have so much expected of them, and there was consequently little surprise at the results secured. The Red Valentine, however, most unexpectedly gave a fair yield, and was the only one that reached the

podding stage. The maximum number of pods produced on any one plant was thirteen, with an average of four pods per plant. The average was lowered because many plants produced only one or two pods. However, the pods were all of a good size, and the plants were surprisingly vigorous.

Most of the varieties run in project 7 were discarded as being unworthy. The Canadian Wonder, the Extra Early Valentine, and the Long Yellow Six Weeks were considered worthy and were carried further.

PROJECT 8. COOL SEASON

Project 8 was the culminating bean project of the entire series of experiments. It consisted of the plantings of all of the promising varieties of both *Phaseolus vulgaris* and *P. lunatus*. These were the Canadian Wonder, the Long Yellow Six Weeks, the Extra Early Red Valentine, the Black Valentine, the Southern Prolific, the Kentucky Wonder, the Tepary, the Henderson's Bush Lima, the King of the Garden Lima, and the Challenger Pole Lima. In part of the cases F_2 seed was used, and in part F_3 seed was used.

The plantings of this project were made from the middle of November, 1916, to a little beyond the first of January, 1917. The season was cool, with constant light showers during the growth and development of all of the short-lived varieties, no irrigation being required excepting for the varieties that continued to grow well to the middle of March. It was possible to give ideal garden treatment to the cultures at all times, and whatever production was secured was obtained under the most favorable conditions.

TABLE IX.—Data for project 8.^a

Variety.	Planted.	Flow- ered.	Service- able.	Seed.	Maxi- mum pods.	Average pods.
Canadian Wonder	Nov. 19	Dec. 14	Dec. 28	F ₃	16	6
Long Yellow Six Weeks	do	Dec. 16	Dec. 29	F ₃	23	11
Extra Early Red Valentine	Jan. 1	Feb. 2	Feb. 16	F ₃	17	9
Tepary	Dec. 10	Jan. 11	Feb. 9	F ₃	34	21
Kentucky Wonder	Dec. 24	Jan. 26	Feb. 20	F ₃	13	7
Southern Prolific	Jan. 6	Feb. 11	Feb. 24	F ₃	36	17
Black Valentine	do	Feb. 10	Feb. 26	F ₃	21	11
Henderson's Bush Lima	Dec. 21	Jan. 26	Feb. 22	F ₂	29	18
King of the Garden	do	(?)	Mar. 29	F ₂	86	27
Challenger	do	(?)	April 3	F ₂	108	34

^a The two large Limas, the Challenger and the King of the Garden, succeeded remarkably well at this planting. The plants were strong and vigorous, there was little sign of disease, and the yield was entirely satisfactory.

TABLE X.—Summary of successful beans.

[C, H, W refer to cool, hot, and wet seasons, respectively; O, a failure. A blank space indicates that the variety was not run.]

Variety.	Planting 1.				Planting 2.				Planting 3.			
	When grown.	Days until serviceable.	Average pods.	Rank.	When grown.	Days until serviceable.	Average pods.	Rank.	When grown.	Days until serviceable.	Average pods.	Rank.
Henderson's Bush Lima	C	66	13	2	H	O	O	O	W	O	O	O
Tepary	C	61	51	4	H	56	44	9	W	O	O	O
Southern Prolific	C	54	23	1	H	57	139	1	W	53	21	2
Long Yellow Six Weeks	C	48	7	2	H	42	16	5	W	O	O	O
Extra Early Red Valentine.	C	40	14	11	H	O	O	O	W	38	15	6
King of the Garden	C	poor			H	O	O	O	C	95	?	1
Challenger	C	poor			H	O	O	O	C	98	?	2
Black Valentine	C	poor			H	O	O	O	W	44	50	1
Canadian Wonder	C	40	14	6	H	42	14	6	W	41	9	5
Kentucky Wonder	C	54	20	3	H	39	28	2	W	51	9	1

Variety.	Planting 4.				Planting 5.			
	When grown.	Days until serviceable.	Average pods.	Rank.	When grown.	Days until serviceable.	Average pods.	Rank.
Henderson's Bush Lima	C	61	35	1	C	61	18	1
Tepary	C	59	13	1	C	61	21	2
Southern Prolific	C	48	11	1	C	50	17	3
Long Yellow Six Weeks	C	41	7	1	C	40	11	4
Extra Early Red Valentine	C	40	4	1	C	45	9	5
King of the Garden	C	85	?	6				
Challenger	C	90	?	7				
Black Valentine	C	45	7	8	C	51	11	8
Canadian Wonder	C	39	6	7				
Kentucky Wonder	C	66	15	1	C	58	7	10

In most cases the crops ran into two seasons, but the season when the greatest growth and development occurred is the one recorded.

The rank given under each planting refers to the rank that the variety received in the project in which it was run, except the rank given in planting 5. This last rank is the rank held by the variety at the close of the experiments.

PROJECT 9. COOL SEASON

Project 9 consisted of the planting of ten varieties of kidney beans on the same ground and at the same season of the year as the first original plantings. Exactly the same treatment was given these varieties as was given those planted the previous year.

The object of this project was twofold: to check the results

secured from the first plantings with those grown under the same conditions a year later and to compare the yields from a number of new varieties with the yields of the old standard varieties. The old varieties grown as checks on the original plantings were the Tepary, the Extra Early Red Valentine, the Dwarf Horticultural, the Michigan White Wax, and the Southern Creaseback. The new varieties run were those that are considered good yielders by American market gardeners. These were the Golden Wax, the French String, the Improved Rustproof Golden Wax, Morse's Stringless Green Pod, and Burger's Pole.

All of the new varieties gave very satisfactory yields for first plantings. There was little sign of disease of any kind, and the plants made fully as vigorous growths as they would make in the temperate zone. Table XI shows all data secured from this project, together with the average production secured from the first plantings of the five old varieties.

TABLE XI.—Data for project 9.

Variety.	Planted.	Flower- ing.	Service- able.	Maturity.	Pods.			Collec- tion No.
					Aver- age.	Maxi- mum.	Aver- age first plant- ing.	
Golden Wax	Nov. 17	Dec. 14	Dec. 25	Jan. 23	10	35		6373
French String	do	Dec. 15	Dec. 26	Jan. 24	7	36		6374
Rust Proof Wax	do	Dec. 16	Dec. 27	Jan. 26	8	20		6375
Extra Early Red Val- entine.	do	Dec. 17	Dec. 25	Jan. 24	7	18	14	6370
Michigan White Wax	do	Dec. 16	Dec. 24	Jan. 28	6	18	20	6371
Stringless Green Pod	do	Dec. 15	Dec. 25	do	9	37		6376
White Creasebrack	do	Dec. 23	Dec. 30	Jan. 31	17	37	19	6379
Dwarf Horticultural	do	Dec. 15	Dec. 24	Feb. 1	8	35	7	6377
Burger's Pole	do	Dec. 23	Jan. 4	Feb. 6	12	26		6378
Tepary	do	Dec. 15	Jan. 21	Jan. 21	21	77	51	6372

It is interesting to note that of the five old varieties run in this project the Tepary and the Red Valentine gave yields twice as great at the first plantings as were those secured in this project, the Creaseback and the Horticultural gave almost the same production, while the Michigan White Wax gave a yield that was insignificant compared with the first. It would be difficult to assign a reason for these differences in production, owing to the fact that some varieties greatly increased their yields, while others fell back. As stated elsewhere, these last plantings were all made on the same land as were the first plantings and received exactly the same treatment. The seasons were much the

same in both years, although that of 1916-17 was somewhat cooler and more suited to the growing of legumes than was the season of 1915-16.

PEAS: PROJECT 1, DRY SEASON

Project 1 consisted of the plantings of several varieties of garden peas in the college gardens. F_1 seed, produced in 1914 by Mr. José Q. Dacanay, a senior student in the College of Agriculture, was used, and the plantings were made during the latter part of March, 1916. The soil was worked into a mellow condition before planting, and the plants were cultivated and irrigated two or three times each week.

The seeds of practically all of the varieties germinated well, and unlike the beans planted at the same time, there was no trouble from insect pests or fungous diseases. But on the other hand the peas were unable to endure the extreme heat during March and April, and notwithstanding the fact that irrigation was used, the majority of the varieties took on a sickly yellowish appearance and died before blossoming. A few varieties remained alive for a good while and produced a few flowers. An occasional pod was produced, but the pods were not in sufficient abundance to be considered a yield of any sort.

This experiment shows that the garden pea is more easily injured by the tropical heat than are the majority of garden beans. It is probable that the pea will have to be cultivated during the cool months only, if satisfactory results are to be secured.

PEAS: PROJECT 2, WET AND COOL SEASONS

Project 2 consisted of the planting of eighteen varieties of peas in my home garden, the plantings being made on September 30, 1916. The varieties were selected so as to include those most popular with American market gardeners and were the following: Prosperity, Alaska, Blue Bantam, American Wonder, British Wonder, Extra Early, Laxtonian, Little Marvel, Mott's Excelsior, Little Gem, Thomas Laxton, Alderman, Abundance, Advancer, Senator, Telephone, Stratagem, and Yorkshire. The plats were arranged side by side, and each plat contained about 10 square meters. The peas were given the same treatment that they are commonly given in the temperate zone, that is, the rows standing about 50 centimeters apart and the seeds drilled thickly in the row.

The heavy rains during October and November proved disastrous, and in spite of the fact that the very best care was given the plants, very few of the varieties produced any crop worth mentioning. The following were complete failures: Alderman, Advancer, Alaska, Stratagem, Telephone, Extra Early, American Wonder, Abundance, Little Marvel, Senator, Little Gem, British Wonder, Blue Bantam, Yorkshire, and Mott's Excelsior. A very few seeds were saved from the Laxtonian and the Thomas Laxton, but not a sufficient quantity to be called a harvest. I believe that the results secured from this project are sufficiently conclusive to show that the pea is unsuited to a season when the rains are heavy.

PEAS: PROJECT 3, COOL SEASON

Project 3 consisted of the original plantings of twenty varieties of garden peas in my home garden. The plantings were made during November and December, 1916, and consisted of the following varieties: Laxtonian, Little Marvel, Mott's Excelsior, Prosperity, Thomas Laxton, Alaska, Blue Bantam, American Wonder, British Wonder, Extra Early, Alderman, Abundance, Advancer, Senator, Stratagem, Horsford's Market Garden, Champion of England, Telephone, Yorkshire Hero, and Large White Marrowfat.

This project gave an excellent opportunity to find out just what each variety of pea would do under good conditions. There was not too much rain, and the atmosphere was cool and moist during the entire growing period of all of the varieties, excepting a few of the latest. The soil was kept in good condition, and good garden treatment was given at all times.

But in spite of the good weather conditions and the excellent care given, most of the varieties proved unsatisfactory. These were in almost all cases the dwarf, early varieties. The following varieties succeeded and were promising at all times: Champion of England (tall and late), Senator (tall and late), Alderman (tall and late), Prosperity (tall and medium early), Stratagem (semidwarf and half-late), American Wonder (semidwarf and early), Thomas Laxton (tall and early), Large White Marrowfat (very tall and late), Horsford's Market Garden (tall and half-late), Alaska (tall and early), Extra Early (medium-tall and early), and Laxtonian (medium dwarf and early). Table XII shows the data secured.

TABLE XII.—Data for project 3.

Variety.	Planted.	Service-able.	Average pods.	Maximum pods.	Average peas per pods.
Champion of England.....	Nov. 19	Jan. 22	4	6	4
Senator.....	do	Jan. 26	4	11	3.4
Alderman.....	do	do	5.6	7	4
Prosperity.....	Nov. 8	Dec. 16	1	2	1.4
Stratagem.....	do	Dec. 15	1.6	2	2
American Wonder.....	do	Dec. 13	1.6	2	1.8
Thomas Laxton.....	do	do	1.3	2	1.5
Large White Marrowfat.....	Dec. 19	Feb. 26	7	12	4.3
Horsford's Market Garden.....	do	Feb. 22	5	11	4
Alaska.....	Nov. 2	Feb. 4	1	2	2
Extra Early.....	do	do	1.4	3	2.2
Laxtonian.....	do	do	1	2	3

All of the tall, late varieties gave a fair yield. If the plants had not stood so close together in the row (the distance between plants being about 6 centimeters), no doubt the average production for each plant would have been materially greater. The Senator, the Alderman, the Marrowfat, and the Horsford's Market Garden produced very strong, vigorous vines that left little doubt as to their being able to adapt themselves to tropical conditions. The results of the first plantings were such as to leave no doubt that the tall late varieties are the ones to be developed for the tropical garden.

PEAS: PROJECT 4, COOL SEASON

Project 4 consisted of the plantings of F₁ seed secured from several varieties, mostly early, run in project 2. All of these plantings were made in January; they consisted of the following varieties: Alaska, Extra Early, Laxtonian, Prosperity, Stratagem, American Wonder, and Thomas Laxton.

It was possible to notice a slight difference in the hardiness of all of these varieties at the second planting, but this was probably due to the favorable weather conditions more than to any other one thing. However, there was one variety, the Stratagem, which in vigorous growth and general hardiness stood so far superior to all neighboring varieties that it was easily noticeable at some distance. The leaves and the stems remained dark green for some time after the weaker varieties had succumbed. The Stratagem did not continue to blossom and produce pods longer than those in the neighboring plats, but its ability to resist the heat and to grow vigorously for some time after the first

Pods became serviceable was sufficient to give it an acceptable rank. The pods were fully a third larger than those secured at the first planting and were well formed. The plants were semidwarf, and the stems and leaves were thicker and sturdier than even the very late varieties.

Table XIII shows the data secured from this planting, with a repetition of the yields made from the first planting.

TABLE XIII.—Data for project 4.

Variety.	Planted.	Service-able.	Maximum pods.		Average pods.	
			First planting.	Second planting.	First planting.	Second planting.
Alaska.....	Jan. 1	Feb. 3	2	3	1	2
Extra Early.....	do	do	3	4	1.4	2.6
Laxtonian.....	do	do	2	3	1	1.8
Prosperity.....	Jan. 14	Feb. 23	2	4	1	1.5
Stratagem.....	do	do	2	4	1.6	2.5
American Wonder.....	do	Feb. 21	2	3	1.6	2
Thomas Laxton.....	do	do	2	3	1.3	1.5

While the data secured from these various plantings of peas are in no sense conclusive—nor are they intended to be so—they are suggestive of possibilities.

In plant-breeding experiments and acclimatization trials a certain variety of plants will turn out almost a complete failure at the first planting and then burst forth with amazing success from the plantings of the F₁ seed; on the other hand, a success at the first planting is not a guarantee of future successes. No doubt the strong, vigorous plant at the first planting has many advantages over the weaklings. The object of this paper was not necessarily to find out whether or not peas would grow in the tropics, for this problem has been conclusively solved for the tropics of America, India, Ceylon, and other points of the East Indies and also conclusively for the Philippines; the object was rather to discover if possible which types and varieties of peas would respond most readily to the climatic conditions in the Philippines and, as stated elsewhere, to secure foundation stock for individual selection work. From more than twenty varieties we have found five that are more or less promising, which will be run in future cultures with the object of establishing them in the Islands. These are the Stratagem, the Senator, Horsford's Market Garden, the Large White Marrowfat, and the Alderman.

SUMMARY AND CONCLUSIONS

From the data we summarize and draw the following conclusions:

1. Kidney beans (*Phaseolus vulgaris*) will usually give a satisfactory yield from newly introduced seed if planted during the cool season.

2. Seeds of the kidney bean lose their vitality readily in the tropics; consequently all seeds should be thoroughly dried and sealed in order to preserve this vitality. Only seeds that are strongly vital will ever be able to resist the attacks of the bean maggot, the worst enemy of the growing of kidney beans in the Philippine Islands.

3. The growing of kidney beans during the dry hot months even under irrigation is not likely to prove worth while. The plants are too tender to endure the intense heat that is reflected from the hot soil during parts of the day.

4. Rich soil, thickly mulched, will produce a fair crop of kidney beans in this locality even during the hotter months.

5. The number of days from planting beans until the crop is serviceable will vary with the different seasons.

6. There is a close correlation between production and the vigor of kidney beans.

7. The bush group of kidney beans is more subject to the bacterial disease caused by *Pseudomonas phaseoli* during the rainy season than is the pole group.

8. The kidney beans, as a general rule, are not suited to the rainy season. Either bacterial disease or the tendency to shoot the pods, owing to excessive moisture, will render the crop too small to come within the bounds of economy.

9. Lima beans (*Phaseolus lunatus*) are likely to be less promising at the first planting than are the kidney beans. However, F₁ seed is likely to respond with a favorable production.

10. The Limas are entirely resistant to the bean maggot.

11. Pole Limas have the tendency to take on the perennial habit in the tropics. Individual plants should be trained on trellises 1.25 meters each way for best results.

12. The Limas require much less care than do the kidney beans. They will yield fairly well during the rainy season and may be made to produce crops during the dry season with slight irrigation. However, plants grown during the cooler months will give the best results.

13. There appears to be no correlation between the production and the vigor of peas.

14. A strong, vigorous variety of peas will produce a strong, vigorous growth from the F_1 seed if grown under the same conditions.

15. Peas are not suited either to the dry season or to the wet season.

16. Peas are little affected by insects or fungous pests if grown during the cool months.

17. The tall late varieties respond more favorably to tropical conditions than do the early dwarfs.

18. Peas do not seem to lose their vitality as readily as beans, yet the seeds should be thoroughly dried and sealed in order to have them as vital as possible at planting time.

In the preparation of this work I received valuable aid and suggestions from Dr. E. B. Copeland, dean of the College of Agriculture; Dr. F. W. Foxworthy, associate professor of dendrology and chief of the School of Forestry; and Prof. C. F. Baker, chief of the department of agronomy.

BIBLIOGRAPHY

- (1) BAILEY. Principles of Vegetable Gardening. MacMillan & Co., New York (1912).
- (2) IDEM. Standard Cyclopedia of Horticulture. The MacMillan Co., New York (1914).
- (3) CORBETT. Beans. *Farmers Bull., U. S. Dept. Agr.* (1915), No. 289.
- (4) DACANAY, JOSÉ Q. Acclimatization of garden peas. *Phil. Agr. & Forest.* (1916), 5, No. 7.
- (5) DE CANDOLLE. Origin of Cultivated Plants. Kegan Paul, Trösch, Trübner and Co., London (1904).
- (6) KINMAN and MCCLELLAND. Experiments of the Supposed Deterioration of Varieties of Vegetables in Porto Rico, with Suggestion for Seed Preservation. Government Printing Office, Washington, D. C. (1916).
- (7) MACMILLAN. Handbook of Tropical Gardening and Planting. H. W. Cave & Co., Colombo (1914).
- (8) MERRILL. Flora of Manila. Bureau of Science publication, Manila (1912), No. 5.

REVIEWS

Preliminary | mathematics | by | Prof. F. E. Austin, B. S., E. E. | Hanover,
N. H. | [7 lines]. | Copyright 1917, pp. 1-169—i-iv. Cloth, price \$1.20.

In the introduction the author seems to be greatly in favor of the English system of units and tries to show that it is more convenient to use it than the metric system. This question of units has been thoroughly discussed by engineers and scientists for some time in the past, and each system has its own followers.

The subject matter in the book is arranged in the most logical order, and the practical applications of the theories discussed are clearly shown.

The problems and examples seem carefully chosen and well worked out and should furnish a guide to students who are beginning to study algebra to enable them to develop the process of correct and logical thinking.

The book will prove valuable to students and teachers and will be a great help for those intending to take examinations in algebra.

As a whole, the book admirably responds to the purpose for which it is intended, and its use is greatly recommended.

F. V. VALENCIA.

The Application of | Physico-Chemical | Theory to technical processes and |
manufacturing methods, | by | Prof. Dr. R. Kremann | (Graz) |
Translated from the German by | Harold E. Potts | M. Sc. (Liverpool)
| and | edited by Albert Mond, Ph. D. | [ornament] | New York |
D. Van Nostrand Company | Twenty-five Park Place | 1915 | Pp.
i-xv—1-212. Cloth, price, \$2.50 net.

“Physical chemistry used to be considered a somewhat theoretical branch of study, but it has recently developed in such a way as to explain many of the empirical observations of technology and to prove extremely suggestive of many new methods, etc.”

Besides the discussion of theory the author has taken up the special topics of: The ideal efficiency of the steam engine; the gas engine; producer gas; water gas; colloidal solutions; the catalytic action of ferments; the drying of linseed oil; vitrification and devitrification; the Deacon process; the contact pro-

cess for sulphuric acid; the manufacture of nitric acid and ether; the manufacture of soap; the caustification of sodium carbonate with alkaline earths; lime burning; Nordhåusen sulphuric acid; roasting lead; the Pattinson process; the iron-reducing method and the formation of matte; nickel matte; puddling; plaster of Paris; the setting and hardening of Portland cement; the weathering of clay; dyeing; vulcanization of rubber; the Parkes process; the ammonia-soda process; the formation of saltpeter from Chile saltpeter and potash.

The book has been well reviewed in the *Journal of the American Chemical Society* (1914), 36, 1065, and in the *Journal of Physical Chemistry* (1914), 18, 457.

The author has covered a great deal of ground and, in general, very well, and the book will greatly aid in making a closer connection between physical and industrial chemistry.

A. J. C. and G. W. H.

506.1
P55
J8

VOL. XIII, SEC. A, No. 3

MAY, 1918

THE PHILIPPINE JOURNAL OF SCIENCE

ALVIN J. COX, M. A., PH. D.
GENERAL EDITOR

SECTION A CHEMICAL AND GEOLOGICAL SCIENCES AND THE INDUSTRIES

EDITED WITH THE COÖPERATION OF

H. C. BRILL, PH. D.; J. R. WRIGHT, PH. D.; G. W. HEISE, M. S.
T. DAR JUAN, A. B., PH. D.; A. H. WELLS, A. B.
R. C. MCGREGOR, A. B.; H. E. KUPFER, A. B.

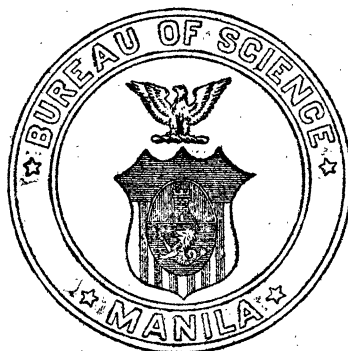

MANILA
BUREAU OF PRINTING
1918

PHILIPPINE JOURNAL OF SCIENCE

A TEN-YEAR INDEX

CONTENTS AND INDEX OF THE PHILIPPINE JOURNAL OF SCIENCE, VOLUME I (1906) TO VOLUME X (1915)

Order No. 449. Bureau of Science Publication No. 8. Paper, 441 pages.
Price \$2, United States currency, postpaid.

One copy of this index has been sent free of charge to each subscriber that has received Volumes XI and XII of the Journal.

This publication consists of:

The complete contents of the first ten volumes of the Philippine Journal of Science, all sections; giving all authors, titles of articles, and page numbers. The exact date of issue of each number is recorded.

An author index, being an alphabetical list of all the contributors. The titles of all the articles are listed under the names of their respective authors.

A subject index. The subject matter is very fully indexed by catch words from the titles, by geographical localities, and by subjects. All systematic names in zoölogy and botany, as well as the thousands of English and local names, are entered in the index.

STUDIES IN PHILIPPINE DIPTERA, II

By M. BEZZI

Order No. 437. Bureau of Science Publication No. 10. Paper, 59 pages and 1 plate.
Price \$0.50, United States currency, postpaid.

This is the second century of Professor Bezzi's enumeration of Philippine species of flies and includes descriptions of new genera and new species.

PLEASE GIVE ORDER NUMBER

Orders for Bureau of Science publications may be sent to the BUSINESS MANAGER, Philippine Journal of Science, Bureau of Science, Manila, P. I., or to any of the following agents:

AGENTS

THE MACMILLAN COMPANY, 64-66 Fifth Avenue, New York, U. S. A.
WM. WESLEY & SON, 28 Essex Street, Strand, London, W. C., England.
MARTINUS NIJHOFF, Lange Voorhout 9, The Hague, Holland.
KELLY & WALSH, Limited, 32 Raffles Place, Singapore, Straits Settlements.
A. M. & J. FERGUSON, 19 Baillie Street, Colombo, Ceylon.
THACKER, SPINK & Co., P. O. Box 54, Calcutta, India.

THE PHILIPPINE
JOURNAL OF SCIENCE

A. CHEMICAL AND GEOLOGICAL SCIENCES
AND THE INDUSTRIES

VOL. XIII

MAY, 1918

No. 3

PRACTICAL OPERATION OF A PRODUCER-GAS POWER PLANT¹

By FRANCISCO R. YCASIANO and FELIX V. VALENCIA

(From the Bureau of Science, Manila)

NINE TEXT FIGURES

Systematic investigations of the fuel resources of the Philippine Islands have shown that coal is of abundant occurrence.² Extensive studies of the calorific values, proximate analyses, physical characteristics, and steaming qualities of coal fuels have been made by Cox.³ In opening up new Philippine coal mines,

¹ Received for publication February 26, 1918.

² Dalburg, F. A., Coal resources of the Philippines, *Min. Res. P. I. for 1911* (1912), 54-62; Coal mining in 1912, *ibid.* for 1912 (1913), 38-40.

Ferguson, H. G., Coal in the Cagayan Valley, *This Journal, Sec. A* (1908), 3, 535-537.

Ferguson, H. G., and Clark, R. N., Coal in the Cagayan Valley, *Min. Res. P. I. for 1909* (1910), 41-42.

Smith, W. D., The coal deposits of Batan Island, *Bull. P. I. Min. Bur.* (1905), 5, 1-56; The nonmetallic minerals, *Min. Res. P. I. for 1907* (1908), 11-12; The geology of the Compostela-Danao coal field, *This Journal, Sec. A* (1907), 2, 377-405; Philippine coal, *Min. Res. P. I. for 1909* (1910), 36-40; The coal resources of the Philippine Islands, *ibid.* for 1910 (1911), 37-56.

³ Cox, Alvin J., Philippine coals and their gas-producing power, *This Journal* (1906), 1, 877-902; The proximate analysis of Philippine coals, *ibid., Sec. A* (1907), 2, 41-66; The relationship between the external appearance and the ash content of Philippine coal, *ibid., Sec. A* (1908), 3, 91-93; Philippine coals as fuel, *ibid., Sec. A* (1908), 301-355; Calorimetry, and the determination of the calorific value of Philippine and other coals from the results of proximate analysis, *ibid., Sec. A* (1909), 4, 171-204; Chemical and physical characteristics of Philippine coal, *ibid., Sec. A* (1912), 7, 1-18; The oxidation and deterioration of coal, *ibid., Sec. A* (1912), 7, 229-316.

the outcrop coal and the slack must be disposed of. It was believed that these would give excellent results in a producer-gas plant and if so would greatly help the industrial development of the country. Low-grade coals when converted into gas for internal-combustion engines give relatively high thermal efficiency. These facts led to a careful study of the various types of producer-gas apparatus and to installation of a suction producer-gas plant in the power house of the Bureau of Science for an additional power unit and for the trial of Philippine fuels in such a plant. In discussing these tests, many details are purposely included, because this is the only plant of its kind in the Philippines, and any data that may be obtained in operating it will serve as a guide in the operation of producer-gas plants that may be installed in the future.

SOURCES OF POWER IN THE PHILIPPINES

A comparison of different types of prime movers involves a consideration of many variable factors such as availability and transportation facility, quality and price of the fuel consumed, availability and price of general supplies, the use of the power, type of the unit, capital invested, interest, depreciation, and location of the machinery. When the power plant is large, the advantages of a given unit are frequently expressed only from the viewpoint of the fuel consumption cost per horsepower hour and include only a statement of the size and type of the prime mover. It is evident that such a statement is inaccurate, but on account of the large number of variables, it is impossible to make a general statement applicable to all types of prime movers included in a given class. The same variables render it possible to make only approximate calculations of power costs and the economy of the performance of various prime movers and, therefore, of the advantages or disadvantages of different types of engines.

As a source of energy in the Philippine Islands there are many waterfalls and streams of large capacity that are entirely undeveloped. At present prime movers are operated exclusively by (1) coal, (2) liquid fuel, or (3) miscellaneous fuels such as rice husks, sugar cane bagasse, saw mill waste, coconut shells or husks, etc. The general practice with regard to the use of these is as follows:

Coal.—The general practice is to fire coal directly under the boiler. The only instance in which it is converted first into producer gas for an internal combustion engine is in the plant of the Bureau of Science, which it is the purpose of this paper to

describe. No coal is converted into gas for use in boiler furnaces. A small quantity of briquetted coal is used from time to time in large plants. There is one cement rotary kiln that pulverizes coal for fire in powdered form. Pulverized coal is neither used in locomotives nor in any boiler installation in the Philippine Islands.

Liquid fuel.—Liquid fuel is commonly used for internal-combustion engines. There is no instance in which liquid fuel is fired under a boiler or converted into producer gas.

Miscellaneous fuels.—Rice husks are in extensive use in rice-mill furnaces with automatic stokers. Sugar cane bagasse is in general use in sugar-mill furnaces with or without automatic stokers. Saw dust, shavings, etc., are in general use in lumber-mill furnaces with automatic stokers. Coconut shells and husks are seldom used under boilers, but find extensive use for drying coconuts.

All of the fuels above enumerated offer possibilities of economical use in gas producers. However, they should not be substituted for coal or other satisfactory fuel, until it is shown by actual experiment that they cannot be used more economically for other purposes. For example, it might be more profitable to market portions of rice husks to be ground for use in mixed stock food than to burn them under a boiler.

DESCRIPTION OF BUREAU OF SCIENCE PRODUCER-GAS POWER PLANT

The gas producer of the Bureau of Science is of the up-draft suction type. It is designed, primarily, for lignite and sub-bituminous coal, which contain a high percentage of moisture and volatile hydrocarbons. This producer is especially suited for the use of Batañ coal, which with most other Philippine coals falls into the above-mentioned class. However, with proper manipulations and regulations, the gas producer can be well used with any coal that does not cake sufficiently to obstruct the formation of gases. The plan of this producer-gas plant is shown in fig. 1.

Gas producer.—The Bureau of Science gas producer has a rated capacity of about 226 cubic meters per hour (8,000 cubic feet). The gas is used to run a four-stroke cycle 69- to 75-horsepower Otto gas engine direct coupled with a 50-kilowatt continuous-current dynamo, which supplies light and power to the Bureau of Science, the Philippine General Hospital, and some of the buildings of the University of the Philippines.

The producer proper, or gas generator, consists of an auto-

generously welded cylindrical iron shell, lined with asbestos fiber and fire brick. The contour, dimensions, and cross section of the producer are shown in fig. 2.

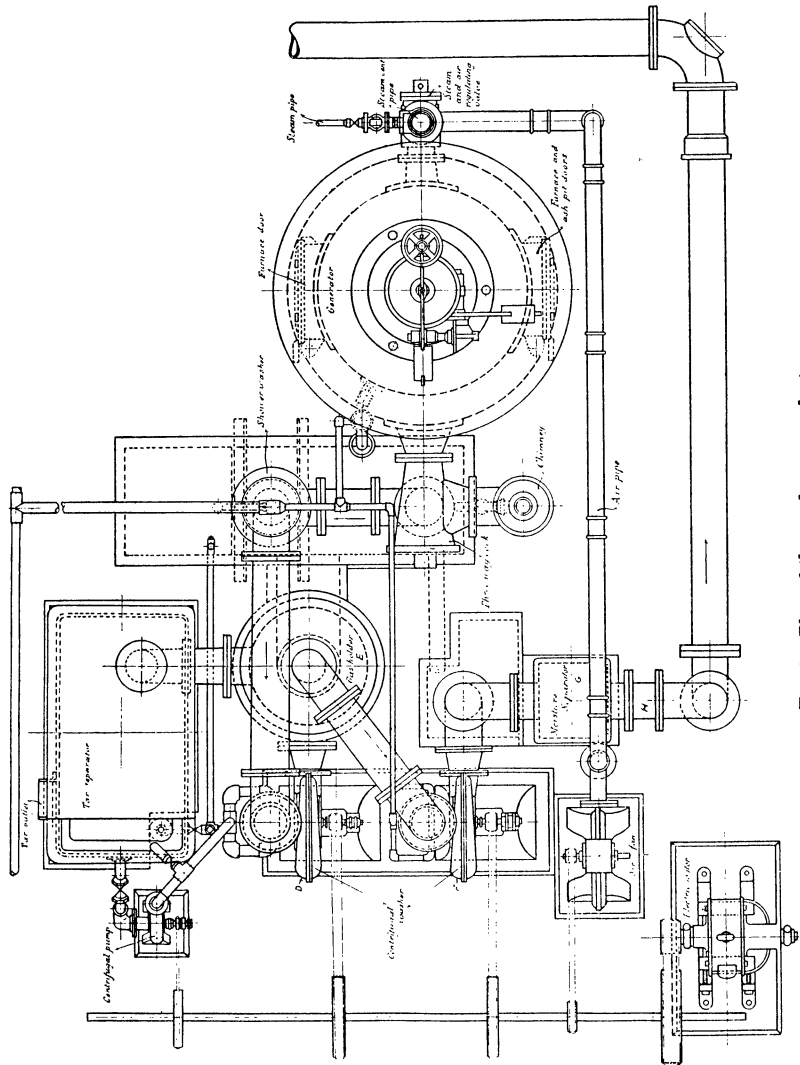

FIG. 1. Plan of the producer-gas plant.

Starting from the grate surface the inside contour of the producer is formed by a cylinder, *A*, 75 centimeters in diameter and 85 centimeters high, by an inverted truncated cone, *B*, 48.8 centimeters high and 130 and 75 centimeters in diameter at the top and bottom, respectively, and by another cylinder, *C*, 130 centimeters in diameter and 54.3 centimeters high. The upper part is as shown in the figure. The distance from the grate surface to the cover plate of the producer is 211 centimeters, and the

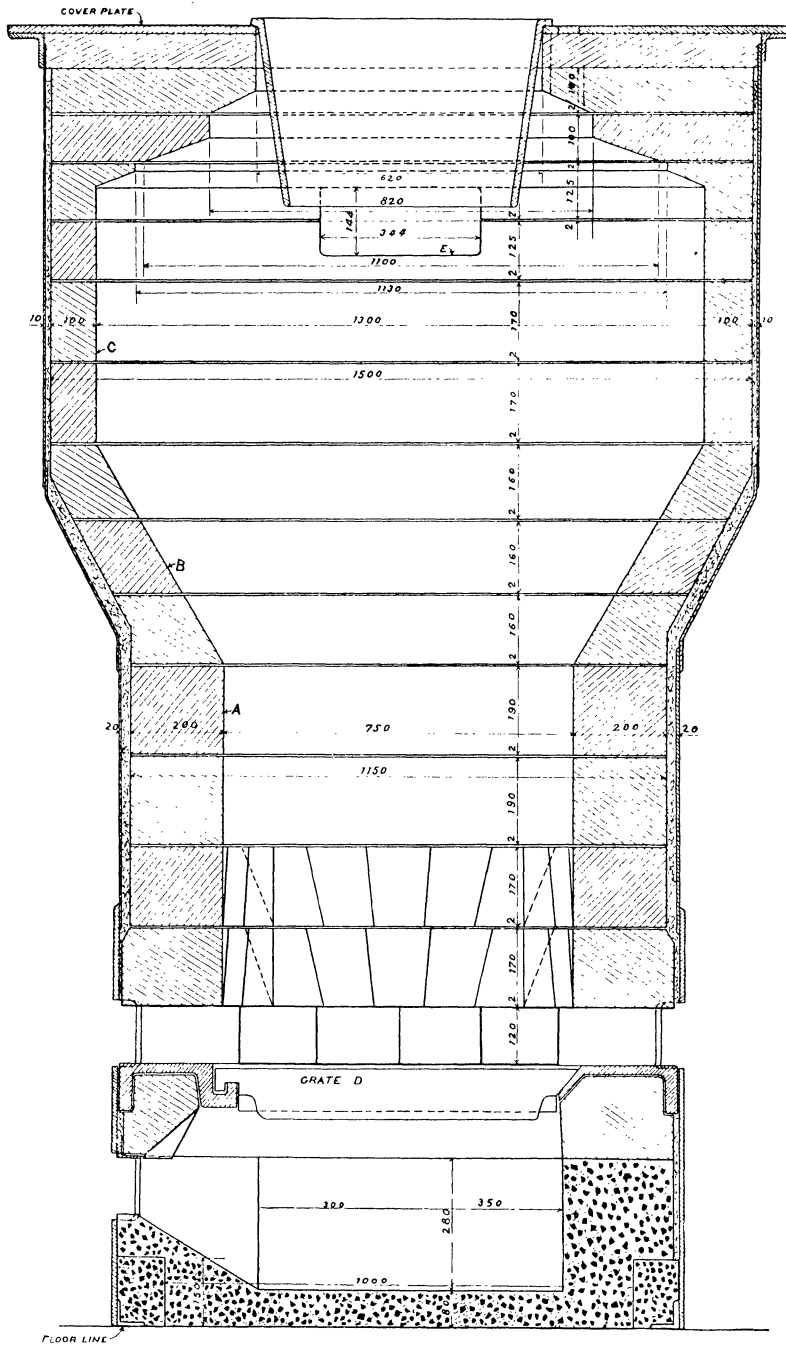

FIG. 2. Section of the gas generator (dimensions in millimeters).

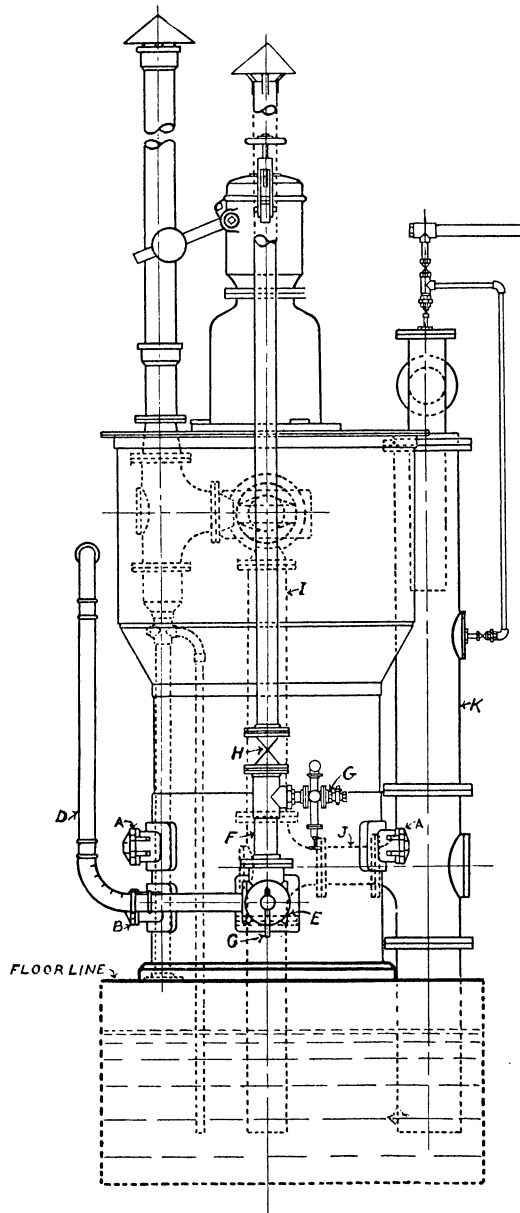

FIG. 3. Side elevation of the gas generator. The air and steam connection is fitted with a four-way cock *C*, by which connection can be made with the blast pipe *D*, with the opening *E* to the atmosphere, or with the pipe *F*, which carries a steam supply pipe *G*, with reducing valve, steam gauge, separator, and steam trap. The pipe *F* opens to the atmosphere by means of a regulating valve *H*.

height of the producer from the floor to the cover head, just beneath the charging platform, is 284 centimeters. The total height of the producer, including the hopper, is 460 centimeters.

Doors.—The producer is provided with two furnace doors (*A*, fig. 3), 50 centimeters by 12 centimeters, located at the level of the grate surface on opposite sides of the furnace. Directly below one of the furnace doors and having the same dimensions is the ash pit door (*B*).

Air and steam supply.—Air and steam are supplied through a connection in the ash pit wall on the side opposite the gas delivery pipe (fig. 3).

Water supply in the ash pit.—The ash pit can be flooded with water, up to a depth of 4 centimeters, if necessary (fig. 4).

Grate.—The grate consists of seventeen stationary bars shown at *D*, fig. 2.

The width of each bar is 15 millimeters, and the distance between any two consecutive bars is also 15 millimeters. The grate has a total area of 3,096 square centimeters, with a ratio between air space and grate surface of one to two.

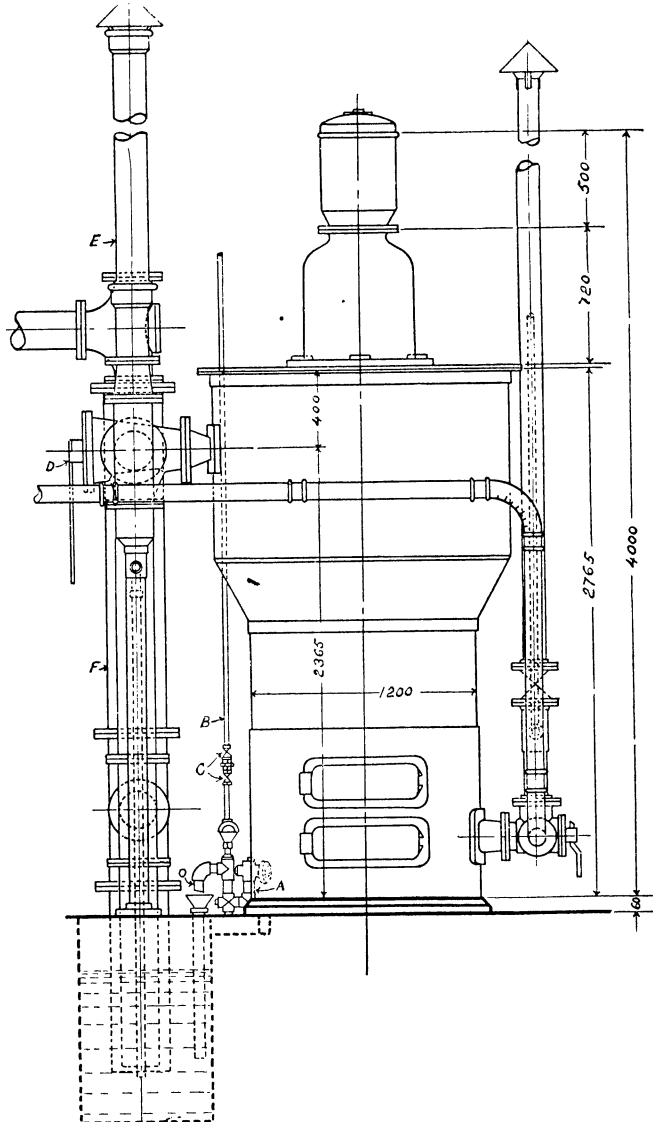

FIG. 4. Front elevation of the gas generator. For the purpose of flooding the ash pit, the water is supplied by the pipe *B*, in which the rate of flow may be regulated by the two valves *C*. The water supply pipe has an exit into the ash pit wall opposite the air intake and also through the *U*-pipe *A*, which constitutes the overflow *O* to the sewer.

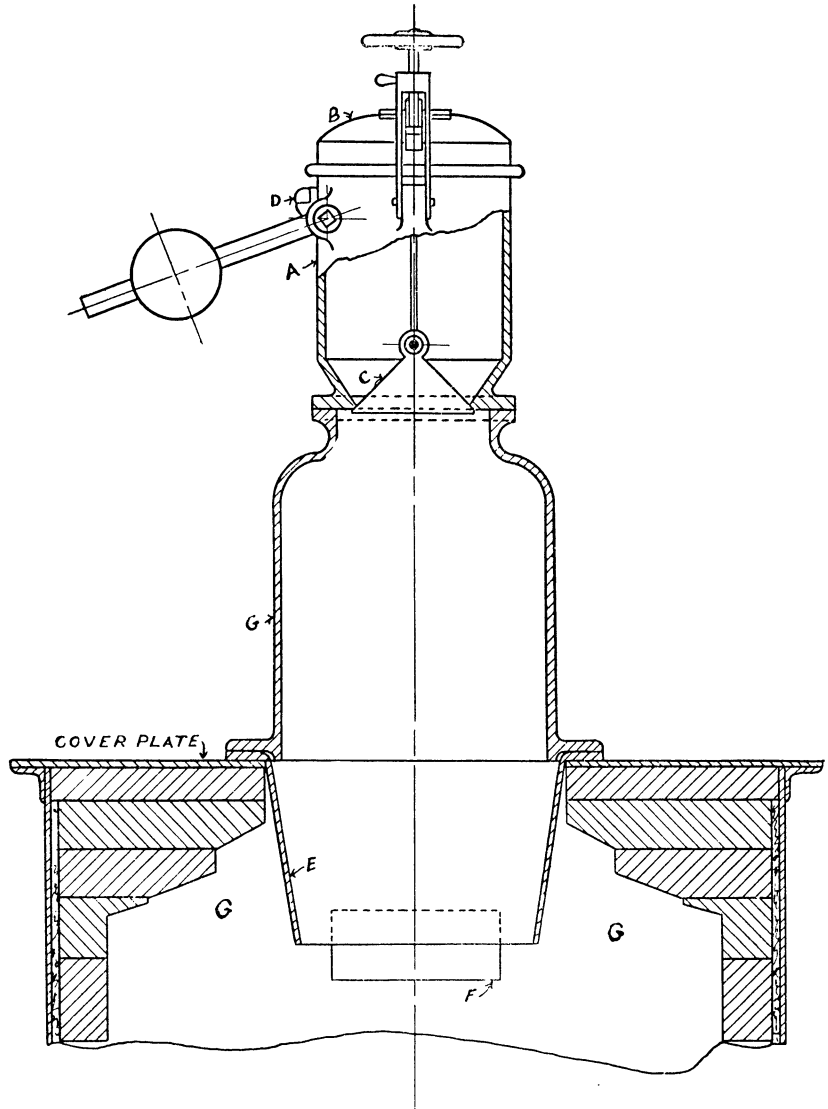

FIG. 5. Hopper. The essential parts of the charging hopper consist of the coal holder *A*, the cover *B*, and the valve *C*. The locking device *D* prevents the opening of the valve *C* when the cover *B* is open, and vice versa. This arrangement avoids the escape of gases when the producer is being charged. The extension of the hopper or the funnel *E* prevents filling the gas generator up to the cover plate, which would choke the gas outlet *F*. By means of this simple device, also, a supply of fuel sufficient for a considerable length of time is maintained in the chamber *G* in the top of the producer.

Hopper.—The coal is fed centrally into the producer by means of a charging hopper (fig. 5), which is bolted on the cover plate of the generator.

Gas outlet.—The gas outlet *E* (fig. 2) is a rectangular opening, 14.4 centimeters by 34.4 centimeters, controlled by the three-way cock *D* (fig. 4), which opens either to the chimney *E* or to the gas pipe *F*.

Cleaning machinery.—The vertical gas delivery pipe *I* (fig. 3), the inside diameter of which is 17.5 centimeters, is water-sealed at the lower end. The gas is forced through the pipe downward, and large quantities of dust, small particles of coal, and flaky ashes are removed. The direction of flow of the gas is changed abruptly by the short horizontal pipe *J*, 17.5 centimeters inside diameter, and by the vertical scrubber *K*, 30 centimeters in diameter. This scrubber, as is shown in the cross section (fig. 6), is provided with two spray nozzles of the umbrella type and with a water seal at the bottom. The water box is provided with an overflow to the sewer. The water spray from the nozzles meets the upward-going gas and removes most of any remaining dust or other residual solid matter in suspension. The water spray also serves the purposes of cooling the gas and of condensing the tar.

The gas, mixed with a certain amount of water that is fed and kept in circulation by a small pump, is next passed through the first centrifugal machine, revolving at a rate of about 2,800 per minute, where the heavy matter, consisting mostly of tar, is largely removed. In the machine the water is mixed intimately with the gas, and they are discharged together. The gas is separated by being collected in a vertical holder, and the water and impurities go into the separating tank. The tar floats on the water and runs through an opening in one side of the tank.

The holder, into which the gas is delivered by the first centrifuge, consists of a cylinder 65 centimeters in diameter by 110 centimeters in height, provided with an opening in one side to fit the discharge pipe. The center of this opening is located 17.5 centimeters above the bottom of the gas holder. A vertical pipe, open at both ends, passes through the bottom of the gas holder. The upper end of this pipe reaches slightly above the discharge pipe, while the lower is water-sealed. Another opening is in the cover of the gas holder and connects with the intake pipe of the second centrifuge.

On leaving the gas holder, the gas passes to the second centrifuge, where again it is mixed intimately with water, introduced as in the first centrifuge. This operation causes the further separation of residual tar in the gas.

The gas is then delivered under pressure to the condenser or moisture separator (fig. 7). This consists of seven perforated plates of equal dimensions, placed vertically on top of packed

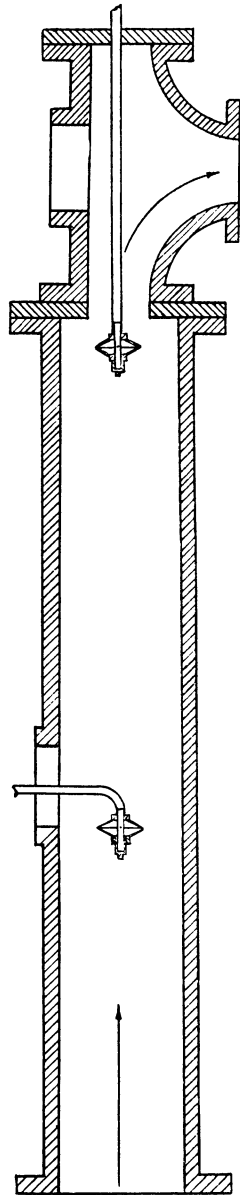

FIG. 6. Scrubber.

position nearest the cylinder head. During this interval both the suction and exhaust valves are closed.

3. Working or third stroke, which begins when the explosive fuel is fired and as soon as the piston again leaves its position nearest the cylinder

excelsior. The perforations are such as to facilitate aggregation of moisture particles, and the water that collects on the plates trickles into the excelsior. The apparatus is incased in a chamber, which has a removable cover and a water-sealed drain for discharging the water that is separated from the gas. After this treatment the gas is passed through a small gas holder. The diameter of the gas holder is greater than the supply pipe, and the pressure and velocity of the gas are considerably reduced in passing through it. This variation in pressure and velocity causes a further deposition of water, which from time to time is blown off through a drain cock in the bottom of the holder. Finally the gas is passed through the last separator, consisting of six baffles, constructed in such a way as to reverse the direction of the flow of the gas six times and practically to eliminate any moisture or tar that is still carried in the gas. This is the final purification, and the gas is delivered into the mixing chamber of the gas engine. The gas holder distributes the effect of the engine suction so as to produce a steady supply of gas to the engine.

Gas engine.—The action of the 4-stroke cycle engine driven by the gas is as follows:

1. Suction or first stroke, which begins as soon as the piston leaves its position nearest the cylinder head and which ends when it reaches its position nearest the crank. During this interval the suction valve is open, while the exhaust valve is closed.

2. Compression or second stroke, which begins as soon as the piston leaves its position nearest the crank and which ends when it reaches its

head and which ends when it reaches its position nearest the crank. During this interval both the suction and exhaust valves are closed.

4. Exhaust or fourth stroke, which begins as soon as the piston again leaves its position nearest the crank and which ends when it reaches its position nearest the cylinder head. During this interval the suction valve is closed, while the exhaust valve is open.

Manner of governing the engine.—The governor of the engine belongs to the class that is called "precision" method of governing.

The mixture of gas and air has a constant proportion at all loads of the engine. This mixture of constant quality is throttled to suit the load by the action of a fly-ball governor, which shifts the position of the fulcrum about which the lever of the mixture inlet valve of the engine turns, thus increasing or decreasing the lift of the valve.

Dynamo.—The gas engine drives directly a 50-kilowatt compound-wound direct-current 110-volt dynamo manufactured in Germany.

This is wired in parallel with two 37.5-kilowatt compound-wound direct-current 110-volt dynamos made in the United States, which are driven directly by two high-speed steam engines provided with Rite's inertia governors. Fig. 8 gives the details of connections of the dynamos to the main switchboard.

Auxiliary motors.—The power plant of the Bureau of Science is run continuously and gives an available electric power supply, at any time, of 110 volts direct current. In choosing the type of motors to run the auxiliary machinery of the producer-gas power plant, it was decided that electric motors were most suitable. A 9-horsepower motor drives the air blower, the centrifuges, and the water pump, and a 2-horsepower motor drives the air compressor, which is used only to fill the compressed-air tank for starting the gas engine.

METHOD OF OPERATION

Starting the producer.—When the producer is empty, ascertain first that the grate is clean and the wall free of clinkers. Open the three-way cock in the gas flue to the chimney. Build a good wood fire on the grate, close the doors, and start the air blower. Feed enough coal through the charging hopper, about 30 kilograms at intervals of about ten minutes, but be careful

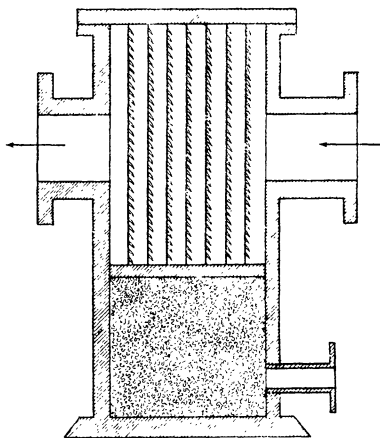

FIG. 7. Condenser.

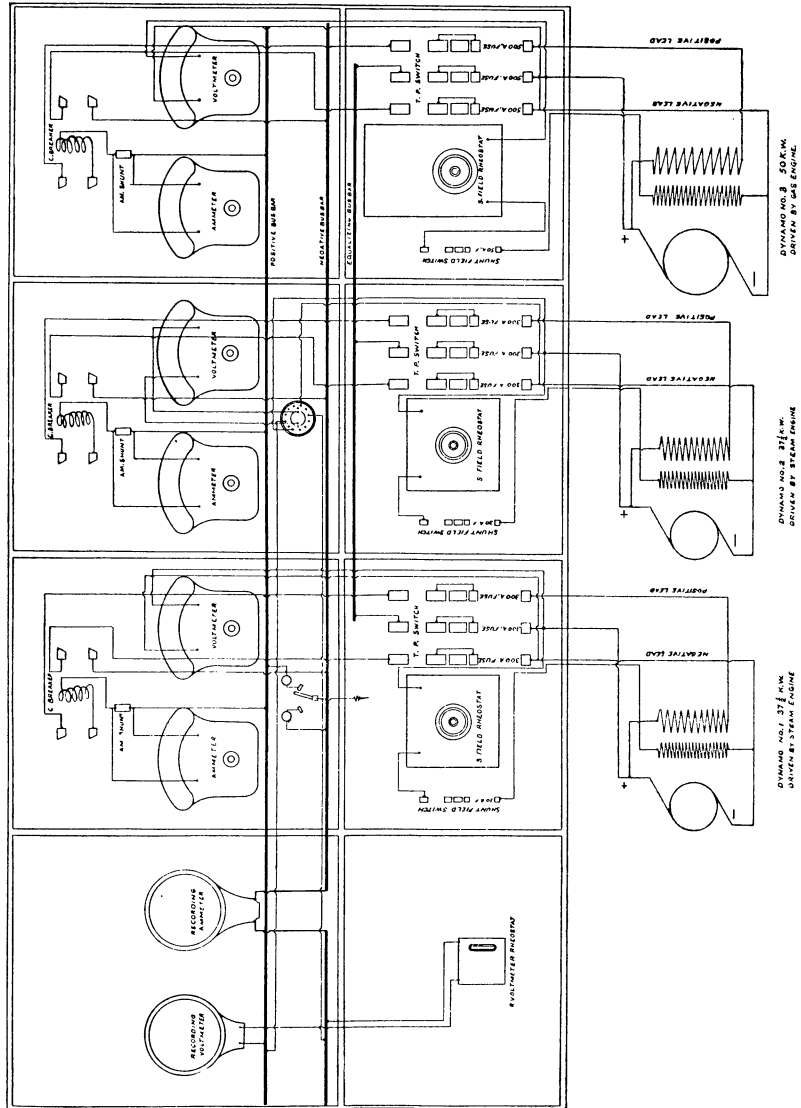

Fig. 8. Switchboard connections.

not to smother the fire. See that the gas purge valve near the exhaust of the engine is open to the atmosphere. Test the gas in the burner connected to the three-way cock; if it is ignited, stop the blower, turn the four-way cock to admit air directly from the atmosphere, and put the three-way cock in the gas flue in position to discharge gas into the delivery pipe. Never stand directly in front of the air intake of the producer, as back firing

may occur during these operations. Introduce water in the ash pit at the rate of about 6 liters per hour; open the water supply of the spray nozzles in the scrubber, the discharge valve of the water pump, and its relief valve located in the discharge pipe; and open also the water supply of centrifuge 2 and start the motor that drives the centrifuges and the water pump. See that this motor is clean and that there is sufficient oil in all bearings. Close the relief of the water pump. The gas is still discharging into the atmosphere, but is ready for use in the gas engine.

When the plant is in operation, the gas producer must be charged up to a permanent level for each particular fuel. The charging must be done at sufficient intervals to keep the quality of the gas practically constant. An interval of every two hours, which takes about ten minutes of the time of one fireman, is usually sufficient.

The starting of the producer is simpler if a fire has been previously built. There is no need of using the air blower; all that is required is to clean the fire and draw the ashes and clinkers out, to open all the necessary valves, and to start the motor that drives the centrifuges and the pump for circulating water. Within ten minutes or less the quality of the gas is good enough to start the engine.

Starting the gas engine.—The gas engine is started by means of compressed air with a pressure of about 12 kilograms per square centimeter.

When the engine is in operation, the time of explosion and the air throttle valve should be regulated to suit the amount and composition of the gas. All moving parts that require lubrication should receive the proper amount of oil. The water in the cooling jacket should not exceed a temperature of about 60° C., and its temperature should be maintained as uniformly as possible.

The proper amount and the kind of oil to be used in an internal combustion engine are very essential in its successful operation. The rate of feed of oil in the most important moving parts of the gas engine in the Bureau of Science is as follows: Eleven to 14 drops per minute in the cylinder; 15 to 20 drops per minute in the piston pin; and 60 to 90 drops per minute in the crank pin. The cylinder oil should be used only once. If the rate of feed of this oil is properly controlled, there will be very little waste. Surplus oil is not only wasted, but forms carbon deposits on piston, valves, and cylinder head, which should be avoided as much as possible.

Stopping the operation.—In stopping the operation of the producer-gas plant, the load of the gas engine should be gradually decreased before disconnecting it completely.

The purge valve should be opened, and the gas throttle of the engine should be closed. Immediately after this operation the motor that drives the auxiliary cleaning machinery should be stopped, the three-way cock in the discharge pipe of the producer left in communication with the chimney, and all water supply stopped. The valve for admitting air in the ash pit should be entirely closed, if the producer is to stand idle less than sixteen hours; otherwise the air intake must be regulated to give just sufficient draft to keep the fire alive. All these manipulations should be performed as quickly as possible, so there is time to return to the gas engine before it slows down too much. The engine should be stopped at the right position for starting. This can be easily done with practice.

RECORDS OF TESTS

The tests were made under actual running conditions without interfering with the regular supply of light and power. The results obtained have been duplicated day after day in ordinary practice. No special preparations were made to obtain exceptionally high records, because we believe that a plant should be judged on what it can ordinarily perform rather than on what it can perform under the most favorable conditions.

Fuel used.—The fuels used were Batan and Fushon coals; the former is black lignite mined in the Philippines, and the latter is Manchurian bituminous coal. The analyses of these fuels are shown in Table I.

TABLE I.—*Analyses of Batan and Fushon coal.*^a

Batan coal:	Per cent.
Moisture	14.63
Volatile combustible matter	39.09
Fixed carbon	38.73
Ash	7.55
Total	100.00
Total calories	5,150
Available calories	4,753
Fushon coal:	
Moisture	4.66
Volatile combustible matter	39.94
Fixed carbon	48.01
Ash	7.40
Total	100.00
Sulphur (separately determined)	0.89
Coking quality	semicoking
Color of ash	grayish white
Total calories	7,133
Available calories	6,633

^a Analyzed by A. S. Argüelles, inorganic chemist, Bureau of Science.

The Batan coal used in firing the producer had been stored for several years.⁴

The size of coal used varied from a powder to about 4 centimeters, and the Fushon coal contained an especially high percentage of slack. Preliminary trials were carried on for several weeks, during which time care was used to determine the influence of different sizes of fuel. The uniformity of size has little influence, and now the coal is used as delivered, either directly or after being screened, for charging the producer. Large lumps are broken into pieces about 3.5 centimeters in diameter.

The data given in Tables II and III are the averages of twenty tests ranging from six to fifty-five hours in duration. In each test readings were taken every fifteen minutes, except during the night shifts. The fuel used in tests 1 to 16 was Batan coal, and in tests 17 to 20 it was Fushon coal.

Table IV shows the results of tests for the entire power plant. These results were computed from data shown in Tables II and III.

Table V gives the analyses of intake and exhaust gases of the gas engine. The numbers of analyses correspond to those shown in the previous tables.

Analyses marked "A" and "B" show very low content of carbon monoxide. These were made on producer gas from a Chinese coal. The coal caked very considerably, and the engine was run only for about four hours, when the producer was clogged, stopping the formation of gas. An attempt was made to over-

⁴ It is interesting to compare its analysis with that made by Cox [*This Journal, Sec. A* (1907), 2, 52] of a fresh sample from the same coal seam secured many years before, whose results are as follows:

Batan Island, Bett's.

	Official method.	Smoking-off method.
	<i>Per cent.</i>	<i>Per cent.</i>
Water	15.41	55.41
	15.42	15.42
Volatile combustible	41.74	39.46
	41.83	39.46
Fixed carbon	39.05	41.02
	38.97	41.00
Ash	3.80	4.11
	3.78	4.12
Total sulphur	0.22	

come this difficulty by mixing different quantities of ashes with the coal to prevent caking, but it was unsuccessful.

In one case the hydrogen content of the gas reached 20.2 per cent. This had a marked effect on the gas engine, causing pounding when it was loaded to about 50 per cent of the rated capacity. Under continuous heavy load the engine does not operate well when the hydrogen in the gas exceeds 14 per cent.

The lower calorific values of the gas per cubic meter as consumed are given in Table VI. The test numbers correspond to the numbers in the previous tables. A Junker gas calorimeter was used in making the determinations. The results were calculated by the formula:⁵

$$C = \frac{1000 W (T_{ow} - T_{iw}) + K (T_{iw} - T_g) + K' (T_{eg} - T_{iw})}{G},$$

where C = calories per cubic meter.

G = liters of gas consumed as registered in the meter.

T_{ow} = temperature of outlet water.

T_{iw} = temperature of inlet water.

T_g = temperature of gas at meter.

T_{eg} = temperature of escaping gases.

W = water passed through the calorimeter in liters.

K, K' = constant calculated by Bates from the specific heats of the average quality of gases, equal to 0.0089 and 0.470 calorie, respectively.

⁵ Latta, Nisbet, *American Producer Gas Practice and Industrial Gas Engineering* (1910), 451.

TABLE II.—Gas-generator tests.

Test No. of test.	Coal.	Water.		Auxiliary motor.		Water gauge.			Temperature.			Ash.	Clinker.		
		Weight of coal.	For ash scrub-pit and fuger. No. 2.	For centrifuge No. 2.	Total.	Amperes.	Volts.	Kilo-hours.	Ash pit.	Producer outlet.	Condenser outlet.			Separator tank.	Producer outlet.
Hrs.	Kilos.	ct. m.	ct. m.	ct. m.	ct. m.	mm.	mm.	mm.	°C.	°C.	°C.	°C.	°C.	Kilos.	
1	6	Batan	296	10.4	6.3	16.7	32.6	10.7	71.1	400.6	114.6	31	5.5		
2	8	do	317	11.83	3.85	15.28	36.4	11.6	39.0	394.0	42.8	52	9.0		
3	6.25	do	328	11.35	2.15	13.5	29.37	11.0	47.0	395.0	41.5	32	8.5		
4	8	do	396	15.35	2.65	18.0	40.1	14.9	49.6	389.0	43.9	27	8.0		
5	8	do	396	8.00	2.90	10.9	39.44	31.0	70.0	375.0	42.1	23	6.0		
6	5	do	242	4.0	1.8	6.0	24.45	20.0	67.0	361.0	40.5	23	12.0		
7	8	do	391	8.2	3.2	11.4	48.7	106.0	41.28	7.9	62.3	388.0	14.5		
8	8	do	389	9.85	3.4	13.25	37.6	5.3	45.0	399.0	138.0	28	15.0		
9	8	do	416	8.4	3.3	11.7	39.2	13.7	30.7	407.0	121.0	29	10.0		
10	6	do	323	7.0	2.5	9.5	28.32	20.0	37.0	404.0	113.0	27	11.0		
11	8	do	400	7.8	3.1	10.9	39.44	22.8	40.4	396.0	103.6	30	13.0		
12	8	do	380	7.8	3.3	11.1	39.76	16.0	22.6	408.0	96.4	50	8.0		
13	8	do	428	7.6	3.4	11.0	36.10	7.5	11.5	412.0	98.5	48	7.0		
14	8	do	417	8.7	3.1	11.8	39.85	4.6	12.0	416.0	100.0	45	9.0		
15	7	do	310	7.1	10.6	17.7	57.1	107.4	42.91	4.88	39.8	67.8	32.8		
16	49.5	do	2,321	56.43	10.5	75.93	53.0	105.1	275.73	9.09	394.3	48.9	118.09	110	51.0
17	7	Fushon	210	6.40	7.5	13.90	48.2	105.2	35.50	76.3	85.8	332.0	50.7	530	26.0
18	8	do	222	11.7	3.0	14.70	54.0	104.0	44.80	43.1	61.3	359.0	61.4	530	41
19	8	do	220	14.0	6.8	20.80	47.0	105.5	39.60	21.1	40.8	348.0	63.4	500	47.9
20	55	do	1,955	60.55	22.5	83.05	50.4	105.0	291.06	45.5	60.4	335.5	58.9	530	60

TABLE III.—Data sheet of gas-engine tests.

Test No.	Duration of test.	Kilo-watt hour.	Volts.	Am-peres.	Water.			Temperature.				
					Cylin-der jacket.	Cylin-der head jacket.	Ex-haust pipe jacket.	Room.	Water jacket.			
									In-take.	Outlet.		
										Cylin-der.	Cylin-der head.	Ex-haust pipe.
Hrs.	M.	cu. m.	cu. m.	cu. m.	°C.	°C.	°C.	°C.	°C.			
1	6	205	-----	-----	6.3	12.2	4.8	-----	-----	-----	-----	-----
2	8	278	110.6	313	8.5	14.05	3.25	33.4	25.1	49.2	40.0	47.7
3	6.25	238	110.4	341.5	6.5	11.35	2.4	33.8	24.9	45.4	40.4	49.0
4	8	298	110.4	327.6	8.4	17.05	2.6	34.1	25.0	46.0	38.7	52.5
5	8	320.8	110.9	320.8	9.5	14.8	2.8	33.6	25.0	42.8	39.9	47.5
6	5	210	110.0	316.9	5.0	9.7	1.7	33.3	25.0	48.0	40.1	50.2
7	8	312	110.8	344.8	7.55	14.9	4.25	-----	-----	-----	-----	-----
8	8	301	110.2	355.2	7.4	15.0	2.95	-----	-----	-----	-----	-----
9	8	303	110.3	328.1	8.2	15.5	5.2	-----	-----	-----	-----	-----
10	6	233	111.1	337.9	6.0	11.3	3.2	-----	-----	-----	-----	-----
11	8	320	109.9	366.7	11.9	16.8	2.8	-----	-----	-----	-----	-----
12	8	287	111.0	310.1	10.4	18.5	3.9	-----	-----	-----	-----	-----
13	8	250	110.7	272.1	12.3	17.3	4.5	-----	-----	-----	-----	-----
14	8	275	110.7	301.6	9.1	18.5	4.4	-----	-----	-----	-----	-----
15	7	236	110.4	282.8	8.9	18.8	3.4	-----	28.4	45.0	40.6	48.0
16	49.5	1,607	109.7	290.6	57.0	105.0	24.7	-----	29.7	42.0	46.6	44.2
17	7	255	109.5	320.9	7.4	17.0	4.0	-----	31.0	49.1	41.6	42.5
18	8	270	109.2	293.7	7.7	19.9	4.9	-----	31.0	49.6	42.6	43.0
19	8	236	109.4	268.6	9.6	19.5	5.6	-----	31.0	49.0	40.8	42.5
20	55	1,816	109.9	312.9	80.1	136.6	33.5	-----	31.0	49.4	41.5	42.3

TABLE IV.—Results of tests of entire power plant.

Test No.	Duration.	Fuel.	Total.					
			Coal consumed.	Power generated.	Power consumed by auxiliary machinery.	Net power generated.	Water used in generator and for cleaning the gases.	Water for cooling the engine.
	Hrs.		Kilos.	k. w. h.	k. w. h.	k. w. h.	cu. m.	cu. m.
1	6	Batan coal	296	205	32.60	172.40	16.70	23.30
2	8	do	317	278	36.40	241.60	15.28	25.80
3	6.25	do	328	238	29.37	208.63	13.50	20.25
4	8	do	396	298	40.10	257.90	18.00	28.05
5	8	do	396	320.8	39.44	281.36	10.90	27.10
6	5	do	242	210	24.45	185.55	6.00	16.40
7	8	do	391	312	41.28	270.72	11.40	26.70
8	8	do	389	301	37.60	263.40	13.25	25.35
9	8	do	416	303	39.20	263.80	11.70	28.90
10	6	do	323	233	28.32	204.68	9.50	20.50
11	8	do	400	320	39.44	280.56	10.90	31.50
12	8	do	380	287	39.76	247.24	11.10	32.80
13	8	do	428	250	36.10	213.90	11.00	34.10
14	8	do	417	275	39.85	235.15	11.80	32.00
15	7	do	301	236	42.91	194.09	17.70	31.10
16	49.5	do	2,321	1,607	275.73	1,331.27	75.93	166.70
17	7	Fushon coal	210	255	35.50	219.50	16.60	28.40
18	8	do	222	270	44.80	225.20	16.40	32.50
19	8	do	220	236	39.60	196.40	20.80	34.70
20	55.0	do	1,955	1,816	291.06	1,524.94	83.05	250.20

TABLE IV.—Results of tests of entire power plant—Continued.

Test No.	Fuel.	Hourly quantities.					
		Coal consumed.	Power generated.	Power consumed by auxiliary machinery.	Net power generated.	Water used in generator and for cleaning the gases.	Water for cooling the engine.
		<i>Kilos.</i>	<i>k. w. h.</i>	<i>k. w. h.</i>	<i>k. w. h.</i>	<i>cu. m.</i>	<i>cu. m.</i>
1	Batan coal	49.33	34.16	5.43	28.73	2.783	3.883
2	do	39.62	34.75	4.55	30.20	1.910	3.225
3	do	52.48	38.08	4.69	33.38	2.160	3.240
4	do	49.50	37.25	5.01	32.23	2.250	3.506
5	do	49.50	40.10	4.93	35.17	1.362	3.387
6	do	48.40	42.00	4.89	37.11	1.200	3.280
7	do	48.87	39.00	5.16	33.84	1.425	3.337
8	do	48.62	37.62	4.70	32.92	1.656	3.165
9	do	52.00	37.87	4.90	32.97	1.462	3.612
10	do	53.93	38.83	4.72	34.11	1.585	3.416
11	do	50.00	40.00	4.93	35.07	1.362	3.937
12	do	47.50	35.87	4.97	30.90	1.387	4.100
13	do	53.50	31.25	4.51	26.73	1.375	4.262
14	do	52.12	34.37	4.98	30.39	1.475	4.000
15	do	43.00	33.71	6.13	27.58	2.528	4.442
16	do	46.88	32.46	5.57	26.89	1.533	3.367
17	Fushon coal	30.00	36.43	5.07	31.36	2.371	4.057
18	do	27.75	33.75	5.60	28.15	2.050	4.062
19	do	27.50	29.50	4.95	24.55	2.600	4.337
20	do	35.54	33.01	5.29	27.72	1.510	4.549

TABLE IV.—*Results of tests of entire power plant—Continued.*

Test No.	Fuel.	Economic quantities.					
		Coal per kilowatt hour generated.	Coal per net kilowatt hour.	Water for generator and for cleaning gases per kilo of coal.	Water for cooling the engine per kilowatt hour generated.	Water for cooling the engine per net kilowatt hour.	Total water used per net kilowatt hour.
		<i>Kilos.</i>	<i>Kilos.</i>	<i>cu. m.</i>	<i>cu. m.</i>	<i>cu. m.</i>	<i>cu. m.</i>
1	Batan coal	1.443	1.716	0.0564	0.1131	0.1351	0.2320
2	do	1.140	1.312	0.0482	0.0928	0.1067	0.1700
3	do	1.378	1.572	0.0400	0.0850	0.0975	0.1617
4	do	1.328	1.535	0.0454	0.0941	0.1087	0.1785
5	do	1.234	1.407	0.0275	0.0844	0.0963	0.1350
6	do	1.152	1.304	0.0247	0.0780	0.0883	0.1207
7	do	1.253	1.444	0.0291	0.0855	0.0986	0.1407
8	do	1.292	1.476	0.0366	0.0812	0.0962	0.1465
9	do	1.372	1.576	0.0283	0.0953	0.1095	0.1501
10	do	1.382	1.578	0.0299	0.0879	0.1001	0.1465
11	do	1.250	1.461	0.0272	0.0984	0.1122	0.1511
12	do	1.324	1.536	0.0292	0.1108	0.1326	0.1775
13	do	1.711	1.953	0.0257	0.1364	0.1594	5.2108
14	do	1.516	1.773	0.0282	0.1163	0.1360	0.1862
15	do	1.275	1.550	0.0588	0.1317	0.1602	0.2514
16	do	1.444	1.743	0.0327	0.1161	0.1402	0.1972
17	Fushon coal	0.827	0.957	0.0790	0.1113	0.1293	0.2050
18	do	0.822	1.011	0.0738	0.1203	0.1443	0.2171
19	do	0.932	1.120	0.0900	0.1470	0.1766	0.2825
20	do	1.076	1.282	0.0424	0.1372	0.1647	0.2119

TABLE V.—Analyses of producer and exhaust gases.^a

Test No.	Kind of gas.	Coal.	Hour.	Carbon dioxide (CO ₂).	Oxygen (O ₂).	Carbon monoxide (CO).	Methane (CH ₄).	Hydrogen (H ₂).	Nitrogen (N ₂).
				P. ct.	P. ct.	P. ct.	P. ct.	P. ct.	P. ct.
1	Intake	Batan	9 a. m.	3.6	2.1	24.8	1.7	7.5	60.3
	Exhaust	do	10 a. m.	15.1	2.9				82.0
	Intake	do	12 m.	5.7	1.3	26.1	2.6	8.3	56.0
	Exhaust	do	2.30 p. m.	14.3	1.5				84.2
4	Intake	do	2.30 p. m.	5.3	0.2	26.8	2.8	9.5	55.4
	do	do	12 m.	3.6	0.3	27.7	3.2	10.9	54.3
	do	do	2 p. m.	4.2	0.5	28.4	2.0	8.1	56.8
	Exhaust	do	2 p. m.	15.7	0.6				83.7
5	Intake	do	10 a. m.	3.7	0.8	28.6	2.3	11.6	53.0
	Exhaust	do	10 a. m.	15.8	3.2				81.0
7	Intake	do	8 a. m.	4.9	0.7	26.0	2.7	9.2	56.5
	Exhaust	do	12 m.	15.6	2.1	2.0			80.3
8	Intake	do	12 m.	4.3	1.0	27.4	2.7	10.6	54.0
	Exhaust	do	2.15 p. m.	16.6	1.6				81.8
9	Intake	do	8 a. m.	4.3	5.9	20.0	0.6	2.2	67.0
	do	do	12 m.	4.4	1.6	25.6	3.0	13.1	52.3
10	do	do	12 m.	4.6	2.2	26.5	2.5	7.9	56.3
	Exhaust	do	12 m.	14.8	1.2				84.0
12	Intake	do	8.50 a. m.	4.1		31.1	2.6	10.0	52.2
	do	do	4 p. m.	3.7		30.3	1.9	10.4	53.7
13	do	do	11 a. m.	5.1	0.2	28.4	2.8	10.9	52.6
	do	do	1.45 p. m.	4.7	1.9	27.0	2.6	14.6	49.2
14	do	do	8.45 a. m.	5.0	0.3	33.8	2.6	5.5	52.8
	do	do	3.20 p. m.	4.5	0.4	28.2	3.1	12.2	51.6
17	do	Fushon	11 a. m.	10.3	0.2	23.4	2.3	19.5	44.3
18	do	do	8 a. m.	4.7	1.0	23.5	1.9	13.1	55.8
19	do	do	11 a. m.	4.1	0.6	23.9	1.3	20.2	49.9
A	do	China	2.30 p. m.	7.7	2.5	23.1	2.3	13.2	51.2
B	do	do	11.30 a. m.	6.3	3.3	18.6	2.7	13.3	55.8

^a Analyzed by A. S. Argüelles, chemist, Bureau of Science.

TABLE VI.—*Calorific values of producer gas.*

Test No.	Coal used in gas generator.	Time of test.	Lower calories per cubic meter of gas under ordinary temperature and barometric pressure.
8	Batan	1.25-1.29 p. m.	1,373.4
	do	1.48-1.52 p. m.	1,409.9
	do	3.17-3.21 p. m.	1,407.2
	do	8.52-8.56 p. m.	958.3
	do	9.24-9.28 a. m.	1,190.6
9	do	9.50-9.54 a. m.	1,226.9
	do	10.20-10.24 a. m.	1,347.4
	do	10.50-10.54 a. m.	1,362.8
	do	11.20-11.24 a. m.	1,418.1
	do	2.19-2.23 p. m.	1,106.0
10	do	2.52-2.56 p. m.	1,222.6
	do	10.06-10.10 a. m.	1,473.4
	do	11.06-11.10 a. m.	1,362.2
	do	11.33-11.37 a. m.	1,348.7
	do	10.23-10.27 a. m.	1,223.7
11	do	11.35-11.39 a. m.	1,298.6
	do	2.04-2.08 p. m.	1,396.2
13	do	3.06-3.10 p. m.	1,333.0
	do	2.55-2.59 p. m.	1,352.5
14	do	11.20-11.24 a. m.	1,376.9
	do	11.30-11.35 a. m.	1,264.5
18	Fushon	1.30-1.35 p. m.	1,565.6
	do	1.49-1.54 p. m.	1,055.9
	do	2.32-2.37 p. m.	1,089.0

Since the preceding tests were made, Uling, Yoshinotani, Hokoku, and Chaoko Chwang coals, a mixture of coconut husks and shells, and copra cake have been successfully used to operate the producer.

The results obtained from the mixture of coconut husks and shells and from copra cake bear a direct important relation to the improvement that can be introduced in the process of drying copra and in the use of these fuels in the copra-oil mills. The results are given in Table VII.

TABLE VII.—Results of tests of mixture of 1 volume of coconut husks to 2 volumes of shells and of copra cake alone used as fuel in a producer-gas generator.

Test No.	Duration of run.	Fuel.	Lower calorific value of fuel.	Lower calorific value of producer gas per cubic meter under ordinary pressure and temperature.	Total fuel.	Total net kilowatt hours generated.	Fuel per net kilowatt hour.
	Hours.				Kilos.		Kilos.
1	6	Mixture of husk and shell 1:2 by volume.	Husk=3,781 Shell=4,060	1047.1	589.0	154.0	3.80
2	7				684.0	208.0	3.26
3	8				714.0	236.5	3.19
4	8				677.5	237.0	2.85
5	10	Copra cake.....	3,855	1455.6	996.0	308.6	3.22

The mixture of husks and shells gave the best result in test 4, which can be accounted as due to the experience acquired by the operators in firing the fuel before this test was performed. The amount of husks and shells on hand was not sufficient to make a series of tests of varying proportions in order to establish beyond doubt the most economical mixture of husks and shells for this particular producer. However, in the preliminary trials this was done during short intervals, and it has shown that pure husks can be burned in this producer only when the load is very light, because its design is adapted for relatively dense fuels. The shells when used alone behaved much like lignite with regard to their load-carrying capacity. The standard charge adopted in the tests was one volume of husks to two of shells, and this mixture was capable of responding to the maximum load of the engine. The fuel was fired as received—the shells in hemispheres and each husk in from four to six pieces. The depth of the fuel was maintained at the full capacity of

the producer. The tests have shown conclusively that mixture of husks and shells can be successfully burned in a suction producer. The design of a producer in which husks are to be used should provide a volume in proportion to the quantity of husks to be used in the mixture; the less this amount, the smaller the producer. When shells alone are to be burned, the producer will conform very closely in design to one for lignite.

Walker⁶ has shown the average weights of husks and shells from 1,000 seashore and 1,000 inland coconuts to be 800 and 286.5 grams, respectively. Based on these figures and on the consumption of 2.85 kilograms of fuel per net kilowatt hour as recorded in test 4, the use of the shells alone from ten nuts to produce 1 kilowatt hour is a very conservative estimate. Therefore a copra plant that uses 10,000 nuts in ten hours' operation will be capable of generating 1,000 kilowatt hours during the same period or 100 kilowatts in one hour. This means that there is a possibility of designing a copra drier that could be either gas or electrically heated, the temperature control of which would be ideal. Besides, there would probably be surplus power for coir or other industries.

On account of the excessive rise in the price of coal copra cake was tried in order to obtain sufficient data to enable us to compare its value with coal. The ash of copra cake is useful as a fertilizer, and its value for such purpose should be deducted from the cost of copra cake. Tables VII and VIII give, respectively, the results of the use of copra cake as fuel and its analysis.

TABLE VIII.—*Analysis of copra cake.*^a

Oil in cake (per cent)	10.86
Moisture (per cent)	11.00
Ash (per cent)	4.70
Potassium oxide (K ₂ O) in ash (per cent)	22.51
Loss on ignition of ash (per cent)	29.02
Lower calorific value of copra cake (calories)	3,855
Higher calorific value (calories)	4,350

^a Analyzed by Messrs. Wells, Peña, and Argüelles, chemists, Bureau of Science.

The results of commercial tests of Uling coal mined in Cebu, P. I., are shown in Table IX.

Table X gives the cost data of the producer-gas plant under discussion.

⁶ *This Journal* (1906), 1, 79.

TABLE IX.—Results of commercial tests of Uling coal (Cebu, P. I.) in the producer-gas power plant of the Bureau of Science.

Test number.	Duration of test.	Total fuel used.	Total ash and refuse.	Total electric energy generated, net.	Coal per net k. w. h.	Calorific value of the coal.		Higher calorific value of the gas.		Thermal efficiency of the entire power plant (including dynamo).		Load factor.	Remarks.
						Higher.	Lower.	B. t. u. per cu. ft.	Calories per cu. m.	Based on higher calorific value.	Based on lower calorific value.		
1	11	Kilos. 535.2	Kilos. 112.9	k. w. h. 330.5	Kilos. 1.61	Calories.	Calories.			Per cent.	Per cent.		The coal was thoroughly washed and stored to dry before firing. It produced some hard clinkers. It can be successfully used in the gas producer.
2	15.5	717.9	101.0	509.0	1.39								
3	15.5	721.5	133.5	460.4	1.56								
Average	14	658.2	115.8	433.3	1.52	6,736	6,256	138	1,230	8.40	9.04	70.20	

TABLE X.—*Cost of installation and operation.*

[Net capacity of the plant, 44 kilowatts.]	
	Pesos.
Total investment, including transportation, foundation, and installation	17,945.00
Fixed charges per annum:	
Interest at 8 per cent	1,435.60
Depreciation at 7 per cent	1,256.15
Maintenance and repairs 3 per cent	538.35
Total	<u>3,230.10</u>
Operating cost (8 hours' daily run):	
Fuel at 8 pesos per ton	927.28
Wages of one power engineer and one fireman	1,825.00
Oil and waste	91.25
Total	<u>2,843.53</u>
Total kilowatt hours for 300 days	74,400
Fixed charges per net kilowatt hour	0.0434
Operating cost per net kilowatt hour	0.0382
Total cost of operation per net kilowatt hour	<u>0.0816</u>
Operating cost (24 hours' daily run), 300 days:	
Fuel at 8 pesos per ton	2,781.84
Wages of three power engineers and three firemen	3,475.00
Oil and waste	205.30
Total	<u>6,462.14</u>
Fixed charges per net kilowatt hour	0.0144
Operating cost per net kilowatt hour	0.0289
Total cost of operation per net kilowatt hour	<u>0.0433</u>

In the calculations in Table X the number of days in a year was taken as three hundred. Both the maintenance and repairs were included in the fixed charges as so much percentage of the capital invested. The water used for cooling the engine and cleaning the gases was not included in the calculation—its cost per kilowatt hour is insignificant.

SPECIAL DIFFICULTIES AND MEANS OF AVOIDING THEM

Clinkers.—The Batan coal, which contains a high percentage of moisture, was formerly used in the producer without any endothermic agent except the natural moisture. At that time the longest safe run was sixteen hours. This was due to the formation of clinkers on the wall of the producer and to a thin but

tough layer of clinker that continuously deposited on the surface of the grate. The removal of this deposit was extremely difficult. The heat evolved by the coal was so intense that it caused the grate bars to burn out. To counteract the excessive heat of the fire bed and the formation of clinkers, water was introduced into the ash pit. This had to be stopped at once, as it produced pounding of the engine caused by premature ignition, on account of the sudden formation of a large percentage of hydrogen in the gas fuel.

The logical means to overcome the excessive heat and the consequent formation of a large amount of clinker and destruction of the grate bars was to use in the fire bed another endothermic agent that would not liberate hydrogen. This could have been obtained by diverting part of the exhaust gases of the engine into the fire bed of the producer. However, the engine exhaust is situated at a considerable distance from the producer, and there was not at hand the necessary piping, so that the introduction of water in the ash pit was tried again and this time was very successful. It was known from the start that Batan coal contains a very high percentage of moisture, which liberates a corresponding high percentage of hydrogen in the gas. The problem was then reduced to establishing the safe limit of water evaporated in the ash pit. For this purpose the small water-supply pipe leading to the ash pit was provided with two valves in series, the lower one was regulated to suit the necessary evaporation and the upper one was left wide open; the lower valve once regulated was left in its position, and the upper one was used only as a service valve for starting or stopping the water supply. Through these valves a very small amount of water was introduced into the ash pit at first. Very slowly this was increased, and at the same time the effect produced in the engine by the gas explosion was carefully noted. It was found by experiment that the evaporation of 6 liters of water per hour was sufficient to protect the grate and the wall of the producer without causing pounding of the engine, even when under full load.

The Fushon coal does not form bad clinkers as long as a small amount of steam is blown into the fire bed with air. The steam is obtained from the boiler that supplies steam to the laboratories. In independent installations the necessary steam can be obtained from a small boiler heated by the gas-engine exhaust. Usually steam is not necessary when the ash pit is kept flooded

with water, which evolves sufficient vapor to protect the grate and the wall of the producer.

Güldner[†] says:

An ample supply of steam to the generator is of advantage from a practical standpoint, since it tends to decrease clinkering and to prevent the rapid burning away of lining and grates. Too high a percentage of hydrogen in the gas, however, leads to heavy explosions in the cylinder of the engine. Only a few engines can stand from 7 to 10% of hydrogen in the mixture, i. e., from 15 to 20% in the producer gas; in most of them, under continued heavy load, a troublesome knocking appears as soon as the gas contains more than 10% of hydrogen. The composition of the producer gas should therefore not be made entirely dependent upon the efficiency of the gasification process.

Disturbing the fire.—When there is necessity of performing an operation that will disturb the fire, if Batan coal is being used, the ash pit should be dried first, as the glowing particles of coal and hot ashes falling in the water will cause a large liberation of hydrogen and consequent pounding of the engine. Once the ash pit is dry, the necessary stoking should be done as quickly as possible so as not to leave the grate unprotected by the cooling action of the water vapor for a long time.

After finishing the operation of stoking, the water supply of the ash pit should be immediately opened after removing any hot refuse consisting of ashes and small particles of coal and broken clinkers that have fallen through the grate. When Fushon coal is used, these precautions are not necessary.

Cleaning the fire.—In cleaning the fire when Batan coal was used, there was no appreciable alteration in the action of the gas engine, even when the period of cleaning lasted as long as twenty minutes. Unfortunately this was not the case with Fushon coal, for, after three minutes of stoking, the gas engine usually slowed down and stopped. The cause of it was found to be due to the formation of a gas very rich in hydrocarbons resulting in a mixture too rich for ignition. Therefore the air throttle valve of the engine was widely opened during the process of stoking, and the gas valve was left at about 20 per cent of its full opening. At these positions of the valves the engine worked well, and the period of stoking could be prolonged even to twenty minutes, affording ample time thoroughly to clean the fire. A few minutes after cleaning the fire the gas and air throttle valves should be returned to their original positions.

[†] Güldner, Hugo, *The Design and Construction of Internal-Combustion Engines*. Translation by Herman Diederichs (1910), 521.

Clogging of the gas flue and the delivery pipe.—When the producer is not fully charged there is considerable deposition of dust and small particles of impurities in the gas flue and in the delivery pipe, necessitating a cleaning about every two weeks. Under this condition the distance from the hopper valve to the surface of the fuel bed is considerable. The gas flue, which is under suction all the time, is located between these two levels. Naturally when the coal is fed into the producer through the hopper valve, it falls in front of the gas flue, and small particles of coal and dust are sucked in and deposited in the flue and in the delivery pipes. Running the producer full prevents the serious clogging of the pipes, and a more uniform gas is obtained.

As another means of avoiding clogging of the flue and the delivery pipe a hole was made in the center of the three-way cock fitted with a removable plug. Through this hole a scraping rod can be inserted, even when the producer is in operation, to remove any deposit in the flue. The vertical and the short horizontal delivery pipes were also provided each with a nozzle for water supply, which can be kept in operation when a long run of several months without stop is desired.

Centrifugal separators.—The circulating water in centrifuge 1 was found to contain ammonia from the gas and tar. The ammonia present attacked the brass blades of the centrifuge to such an extent that complete renewal within about four weeks was necessary. Iron blades were substituted, and from that time no more trouble from this source was experienced.

Hopper.—The hopper used for coal and lignite (fig. 6) was found to be unsuited for the mixture of coconut husks and shells due to its small opening and capacity. A special hopper for this fuel was designed, as shown in fig. 9.

CARE AND MAINTENANCE

The care necessary in a producer-gas plant is less than that required in a steam plant of the same capacity. In the producer plant there is no boiler. This obviates the need of the continuous attention of at least one fireman, who is required to throw small amounts of coal into the boiler furnace at short intervals, distributing it evenly over the grate surface in order to attain high efficiency in operation. The only attention required in such a producer-gas plant as that at the Bureau of Science is to charge the gas producer full or nearly so every one or two hours when coal is the fuel, which takes about ten minutes of the fireman's time, and to draw out the ashes and clinkers about every ten hours, or requiring in each operation about fifteen minutes.

Sometimes it is necessary to break the clinkers on the grate surface, which is done by passing the hook bar underneath between the grate bars. This operation takes about five minutes every three hours, according to the condition of the fire bed. Add to this the time required for poking the fuel when the fire has a tendency to hang, say four minutes about every four hours, we have a total of less than about five hours in twenty-four of time expended. Or the total time of actual stoking necessary in a 69- to 75-horsepower producer is only about 20 per cent of that required in a boiler of about the same horsepower rating.

Besides the fireman, there is usually an operating engineer, as in the steam plants, but his time is not wholly taken up, since there are no steam boilers, steam pipes, or auxiliaries under high steam pressure. The routine duty of the engineer in a producer-gas plant is to see that the engine and auxiliaries are properly lubricated, that the water jacket has a uniform correct temperature, and that the quality of the gas is practically constant and of the highest obtainable calorific value. The operating engineer must also know how to judge whether the fire bed needs stoking or not without actually seeing it. He should make a periodical five-minute inspection at intervals depending on the skill and trustworthiness of the fireman. The rest of the time of the engineer can be given to other work.

It must not be implied that what has been enumerated above constitutes the only care necessary in a producer-gas plant. The purifying apparatus, piping, and auxiliaries must be cleaned about once a month, depending on the quality of the fuel; the valves of the engine must be also cleaned and, if necessary, ground from time to time; the gas engine must be thoroughly cleaned about once every month, depending on the number of hours of use and the purity of the gas. The producer can be

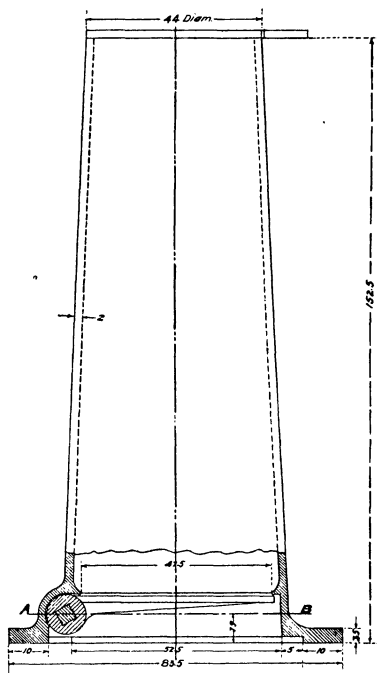

FIG. 9. Special hopper for coconut husks and shells.

successfully run for many months without any trouble if it is properly handled, but it is advisable to empty it for inspection whenever the gas engine is stopped for general cleaning and to overhaul and clean it thoroughly if necessary. Still the necessary work in a producer-gas plant is far less than that required in cleaning the boiler, steam engine, and auxiliaries in a steam plant of similar capacity.

CONCLUSIONS

1. The operation of the producer-gas plant at the Bureau of Science is very simple, and almost any solid combustible may be used. So long as the engine is properly lubricated and cooled, the necessary attendance is practically reduced to charging the producer from every one hour to two hours and to cleaning the fire once or twice a day.

2. The producer-gas plant of the Bureau of Science is very reliable. It has been in daily operation for nearly five years, and since 1914 has been operated continuously for twenty-four hours each day, except for the necessary short stops for cleaning at intervals of from two weeks to two months. The brick lining of the producer has not been renewed; it has required small repairs only from time to time, and there is no evidence of its being badly deteriorated.

3. At the Bureau of Science the parallel operation of the 50-kilowatt dynamo driven by the producer-gas engine and the two 37.5-kilowatt dynamos coupled to the steam engines is very satisfactory. Both the gas and steam engines respond quickly to any change in load.

4. With the same fuel, the load necessary to generate one kilowatt hour in the Bureau of Science producer-gas plant is only about a third of that required to produce the same energy in a steam plant of approximately the same capacity.

5. All the fuels experimented with were satisfactory, but the advantages in regard to minimum attendance of the producer and simplicity of operation are in favor of them in the following order, namely, Batan (Philippine) coal, Hokoku (Japanese) coal, coconut shells, Fushon (Manchurian) coal, Uling (Philippine) coal, copra cake, Chaoco Chwang (Chinese) coal, and Yoshinotani (Japanese) coal.

6. The results of the tests of coconut shells and husks described in this paper indicate the possibility of using the producer gas or the electric energy derived from it for copra drying and for driving machinery in connection with the copra industry and for extracting husk fibers.

7. A producer-gas plant of the type used in the Bureau of Science is well adapted for, and can be exceedingly economically and satisfactorily operated in, the Philippine Islands. The continuity of its operation is assured, since the producer can burn not only Philippine fuels, but also any one of several imported coals that are available in the local market.

8. A producer-gas plant solves the problem of smoke nuisance.

9. The installation of producer-gas plants in the Philippine Islands will greatly help in the conservation of fuels and in solving the fuel problem.

ILLUSTRATIONS

TEXT FIGURES

- FIG. 1. Plan of the producer-gas plant.
2. Section of the gas generator (dimensions in millimeters).
 3. Side elevation of the gas generator. The air and steam connection is fitted with a four-way cock *C*, by which connection can be made with the blast pipe *D*, with the opening *E* to the atmosphere, or with the pipe *F*, which carries a steam supply pipe *G*, with reducing valve, steam gauge, separator, and steam trap. The pipe *F* opens to the atmosphere by means of a regulating valve *H*.
 4. Front elevation of the gas generator. For the purpose of flooding the ash pit, the water is supplied by the pipe *B*, in which the rate of flow may be regulated by the two valves *C*. The water supply pipe has an exit into the ash pit wall opposite the air intake and also through the *U*-pipe *A*, which constitutes the overflow *O* to the sewer.
 5. Hopper. The essential parts of the charging hopper consist of the coal holder *A*, the cover *B*, and the valve *C*. The locking device *D* prevents the opening of the valve *C* when the cover *B* is open, and vice versa. This arrangement avoids the escape of gases when the producer is being charged. The extension of the hopper or of the funnel *E* prevents filling the gas generator up to the cover plate, which would choke the gas outlet *F*. By means of this simple device, also, a supply of fuel sufficient for a considerable length of time is maintained in the chamber *G* in the top of the producer.
 6. Scrubber.
 7. Condenser.
 8. Switchboard connections.
 9. Special hopper for coconut husks and shells.



FERTILIZER EXPERIMENTS WITH SUGAR CANE ¹

By JOSÉ MIRASOL Y JISON

(From the College of Agriculture, Los Baños)

TWO TEXT FIGURES

Sugar cane is an exhausting crop on any soil. According to Maxwell,² a ton of sugar, when the trash of the cane is returned to the soil, removes from it 12.7 pounds (5.77 kilograms) of nitrogen, 35.3 pounds (16.45 kilograms) of potash, and 8.2 pounds (3.72 kilograms) of phosphoric acid. An 8-ton sugar crop per hectare would then remove 46.2 kilograms of nitrogen, 131.5 kilograms of potash (K_2O), and 29.8 kilograms of phosphoric acid (P_2O_5). The common practice in the Philippines is to plant cane after cane on the same field without restoring the plant food removed by the crops. The world's experience is that no one crop can be continuously and profitably grown on the same unfertilized soil, no matter how rich it was at the beginning. In Queensland, Maxwell analyzed some virgin soils and some that were continually cropped with cane. A comparison of his results showed a loss of 31 per cent of nitrogen, 42.2 per cent of potash, and 37.2 per cent of lime. Considering that the sugar produced in the Philippines in one year (1916) amounted to 374,000 tons from 179,761 hectares of land,³ it is apparent that the question of maintaining the fertility of our sugar lands is of national importance.

The use of commercial fertilizers for cane was recently introduced into the Philippines. But the failure of some farmers in their attempt to increase the yield of cane by the use of commercial fertilizers has created an atmosphere of prejudice against their use among local cane growers. This condition is rather unhappy. As a general proposition there is nothing wrong about the use of commercial fertilizers. The failure of the farmers who tried to use them was due to a lack of information regarding the manurial requirements of their soils, to be

¹ Portion of graduation thesis for the degree of Master of Science, No. 3. Received for publication January 31, 1918.

² Sugar Cane. Published by German Kali Works.

³ This figure was obtained from the Bureau of Agriculture booth stand at the February, 1917, Philippine Carnival.

obtained by carefully controlled tests and trials. To fill this deficiency and to develop a system of fertilization trials that could be followed elsewhere in the Islands, I undertook the present experiments.

METHOD AND TIME OF APPLICATION OF FERTILIZERS

Deerr,⁴ speaking of the proper application of various artificial manures, says that readily soluble forms of fertilizers such as nitrate of soda and ammonium salts should be applied as top dressings. Organic forms of nitrogen requiring the action of soil organisms must be buried 5 or 6 centimeters in the soil. Superphosphates are applied either as top dressings or are buried at a slight depth. Basic slag and mineral phosphates must be incorporated in the soil. Potash salts should be also incorporated.

Most investigators agree that the best time for application is during the early growth of the cane. They differ as to the advisability of a second application. Watt's⁵ experiments in the Leeward Islands led him to conclude that the one-application system is better. In Hawaii, however, the application of nitrate of soda at the second growing season is found beneficial. The two-time application is practiced in Barbados.

THE AMOUNT OF FERTILIZERS TO BE APPLIED

For the stiff clay of Demerara, Harrison⁶ recommended the application of 50 pounds (54.24 kilograms per hectare) of nitrogen in the form of sulphate of ammonia, with 500 to 600 pounds of ground phosphate slag per acre (543.12 to 654.48 kilograms per hectare). In Barbados the planters use from 40 to 80 pounds of nitrogen in the form of nitrate of soda and ammonium sulphate, combined (43.44 to 86.88 kilograms per hectare), and 80 to 100 pounds (87 to 109 kilograms per hectare) of sulphate of potash per acre. In Louisiana the amount of fertilizer used is from 400 to 700 pounds per acre (436.32 to 872.64 kilograms per hectare). In Hawaii as much as 2,400 kilograms of fertilizers are applied per hectare.⁷ The amount of fertilizers to be applied is a question that should be determined for each locality.

⁴ Deerr, Noel, *Cane Sugar* (1911).

⁵ *Ibid.*

⁶ *Sugar Cane*. Published by German Kali Works.

⁷ Deerr, Noel, *Cane Sugar* (1911).

PRESENT EXPERIMENTS

The present experiments were carried out on a clay-loam soil from which a crop of sweet potato had been harvested. The land was first thoroughly plowed, and then fifteen plots of 450 square meters each were laid off. The Los Baños white cane was used. It had been previously found that this variety of cane would yield 5.86 tons of 96° sugar per hectare.⁸ The seeds were all selected, as to size, from a field of plant cane. The rows were 1.5 meters apart, and the seeds were laid 25 centimeters from end to end at the bottom of furrows 30 centimeters deep. Planting began May 8, 1916, and was finished May 10, 1916. On May 16 the canes were nearly all above the ground. On July 15 the stools in each plot were counted. The percentage of success in each plot is shown in Table I.

TABLE I.—*Los Baños white cane planted in a clay-loam soil.*

Plot.	Seeds planted.	Stools counted.	Suc-cess.	Plot.	Seeds planted.	Stools counted.	Suc-cess.
			<i>P. ct.</i>				<i>P. ct.</i>
1	600	483	80	9	600	507	84
2	600	472	79	10	600	520	88
3	600	405	68	11	600	469	78
4	600	496	83	12	600	502	83
5	600	499	83	13	600	544	90
6	600	433	72	14	600	517	86
7	600	547	91	15	600	433	72
8	600	458	76				

On July 22 the fertilizers were applied. The cost of fertilizers, as computed from the Manila prices for 1916, and their composition (as determined by Doctor Deming, formerly of this college) are given.

TABLE II.—*Composition and cost of fertilizers.*

	Peso per kilo.
Lime	0.02
Dried blood, 14 per cent nitrogen	0.10
Sulphate of ammonia, 20 per cent nitrogen	0.23
Nitrate of soda, 15 per cent nitrogen	0.20
Sulphate of potash, 40 per cent potash (K ₂ O)	0.23
Double superphosphate, 20 per cent phosphoric acid (P ₂ O ₅)	0.22

Table III shows the plan and the corresponding cost of fertilization per hectare.

⁸ *Phil. Agr. & Forest.* (1915), 4, Nos. 5-6.

TABLE III.—Rate of applications and cost of fertilizers per hectare.

Plot.	Fertilizers.	Rate of application per hectare.		Cost of fertilizers and their application per hectare.	
		Kilos.	Pesos.		
1	Control.....				
2	Lime.....	1,000	20.28		
3	Dried blood.....	320	34.10		
4	Nitrate of soda.....	320	66.41		
5	Sulphate of potash.....	320	75.96		
6	Sulphate of ammonia.....	320	75.96		
7	Sulphate of potash and double superphosphate.....	640	75.96		
8	Sulphate of ammonia and sulphate of potash.....	640	144.58		
9	Control.....				
10	Nitrate of soda and double superphosphate.....	640	134.80		
11	Sulphate of ammonia and double superphosphate.....	640	144.36		
12	Nitrate of soda and sulphate of ammonia.....	640	149.14		
13	Sulphate of ammonia, sulphate of potash, double superphosphate, and nitrate of soda.....	1,000	280.41		
14	Sulphate of potash, nitrate of soda, and double superphosphate.....	1,000	219.78		
15	Sulphate of ammonia, sulphate of potash, and double superphosphate.....	1,000	216.78		

Nitrate of soda at the rate of 320 kilograms per hectare was added to plot 13 two months after the first application.

The complete fertilizers were mixed according to the formula 8-6-8, that is to say, the ratio between the nitrogen, potash, and phosphoric acid was as 8:6:8.

The variety used in these experiments, according to a previous investigation by me, matures in about nine months. The canes were analyzed from March 5 to 16 and were harvested from March 13 to 22. The results of the analyses are shown in Table IV, and the field data are shown in Table V.

Table IV shows that the complete fertilizer plot (plot 14) with nitrogen in the form of nitrate of soda gave the highest purity in the juice; next comes plot 5, to which sulphate of potash alone was applied; and then follows plot 13, which was treated with complete fertilizers and given a subsequent application of nitrate of soda.

TABLE IV.—Showing results of experiments with fertilized plots.

Plot.	Juice (determined).				Bagasse (determined).			Cane (calculated).			Juice extraction by hand mill.	98° sugar from 100 tons of cane.	Quality of cane.
	Corrected brix.	Sucrose.	Purity.	Invert sugar.	Sucrose.	Invert sugar.	Fiber.	Sucrose.	Invert sugar.	Fiber.			
1	15.47	12.64	81.70	1.13	7.08	0.14	32	10.90	0.82	10.13	68.8	9.82	1:10.2
2	15.68	13.11	83.60	0.95	7.26	0.03	35	11.25	0.65	11.01	68.4	10.26	1:9.8
3	16.15	13.86	85.82	0.70	8.76	0.07	27	12.16	0.49	9.20	66.6	11.25	1:8.9
4	14.68	11.96	81.60	1.34	7.60	0.16	34	10.68	0.92	10.00	70.5	9.60	1:10.2
5	16.22	14.52	89.52	0.49	8.05	0.04	26	12.43	0.34	8.32	67.8	11.72	1:8.5
6	15.55	12.68	81.54	1.31	6.73	0.13	36	10.90	0.95	9.15	70.2	9.81	1:10.2
7	16.24	13.79	84.29	0.76	13.21	0.08	34	13.61	0.55	10.45	69.8	12.50	1:8.0
8	14.87	12.08	81.30	0.83	11.42	0.10	39	11.90	0.61	11.33	70.3	10.70	1:9.9
9	15.82	13.08	82.68	0.98	6.66	0.11	35	11.34	0.75	10.08	73.0	10.30	1:9.7
10	14.73	11.68	79.29	1.30	6.96	0.15	40	10.12	0.85	11.73	70.0	9.00	1:11.0
11	12.50	9.82	78.56	1.67	4.25	0.19	32	8.21	1.24	8.96	71.2	7.24	1:14.0
12	17.30	14.97	86.53	1.64	8.96	0.12	34	13.10	1.16	10.61	69.0	12.15	1:8.2
13	18.86	16.48	87.38	0.72	12.05	0.09	39	15.22	0.54	12.16	71.7	14.21	1:7.0
14	19.72	17.78	90.16	0.53	9.95	0.06	38	15.22	0.37	12.20	67.4	14.43	1:6.9
15	17.82	15.12	84.90	0.89	9.43	0.08	29	13.32	0.47	9.48	68.4	12.25	1:8.0

TABLE V.—Field data of sugar cane in fertilized plots.

Plot.	Plot results.										Hectare basis.			
	Stools two months after planting.	Stools at harvest.	Mortality at harvest.	Canes to the stool.			Cane measurements.			Actual weight of canes at harvest.	Waste.	Yield of cane.		Gain or loss over average of checks.
				Average.	Lowest.	Highest.	Average diameter.	Average height.	Average weight of 100 canes.			Kilos.	Tons.	
1	483	471	2	5	1	14	3.02	2.41	131.06	3,233	2	71,844.44	71.84	-----
2	472	470	0.4	6	1	13	3.12	2.25	120.27	3,535	2	78,555.55	78.55	+ 0.76
3	405	405	0	6	2	14	2.77	1.74	117.04	3,035	1	67,444.44	67.44	-10.33
4	497	441	9	7	1	18	3.04	2.38	121.26	3,889	3	86,422.22	86.42	+ 8.63
5	499	499	0	6	1	17	3.09	2.59	97.92	3,156	2	70,133.33	70.13	- 7.66
6	433	429	9	7	1	17	2.96	2.13	125.32	4,043	2	89,844.44	89.84	+12.05
7	547	547	0	6	1	19	3.05	2.51	125.77	4,128	3	91,733.33	91.73	+13.94
8	458	456	0.4	7	1	21	2.92	2.68	126.86	4,310	4	95,777.77	95.77	+17.98
9	507	507	0	7	1	18	2.56	2.51	103.80	3,769	1	83,765.55	83.75	-----
10	529	514	2	6	1	16	2.77	2.51	107.29	3,736	4	84,425.33	84.42	+ 6.94
11	469	467	0.4	7	1	20	3.50	2.69	128.07	4,288	3	95,288.88	95.28	+14.50
12	502	497	0.8	6	1	23	2.84	2.77	125.42	3,710	2.5	82,444.44	82.44	+ 4.65
13	544	543	0.1	6	1	18	3.24	2.72	128.66	4,142	2	92,044.44	92.04	+14.25
14	517	486	6	7	1	25	3.27	2.67	103.40	3,981	3	88,466.66	88.46	+10.85
15	433	395	0.9	7	1	22	3.14	2.48	106.98	3,861	2	85,800.00	85.80	+ 8.01

The combination of nitrate of soda with superphosphate (plot 10) and that of the latter with ammonium sulphate (plot 11) show the lowest purity. The plots with nitrate of soda (plot 4) and sulphate of ammonia (plot 6) are below the check plots 1 and 9 in purity. Plot 11 gave the lowest percentage of sucrose in the cane, while the two plots with complete fertilizers with nitrogen in the form of nitrate of soda show the highest sucrose content. With the exception of plots 8, 10, and 11, all of the fertilized plots show a higher percentage of sucrose than either check.

The effect of fertilizers on the purity of the juice and the sucrose content of the cane can be best understood with the aid of fig. 1, in which curve 1 represents purity and curve 2 sucrose content of the cane. It will be noticed with interest that the rise and fall of the purity is accompanied by a similar course of the percentage of sucrose in the cane, with the exception of

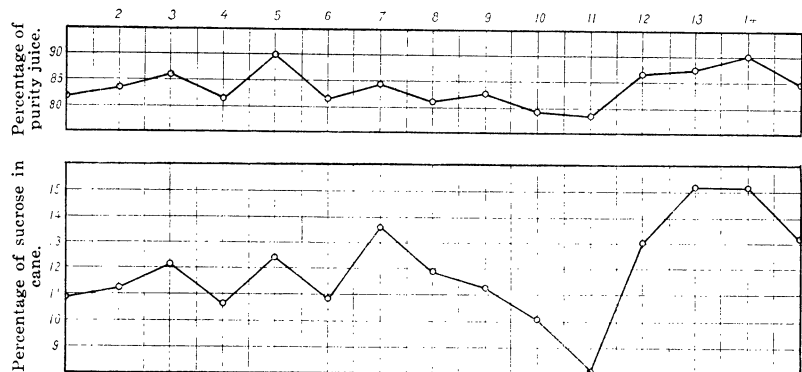

FIG. 1. Curve 1, effect of fertilizers on the purity of juice; curve 2, sucrose content of the cane.

plot 4, where the increase in purity is not accompanied by any increase in the sucrose content as compared with plot 13.

The effect of manuring on the saccharine content of the cane is a subject that up to the present time is not satisfactorily known. Eckart,⁹ in Hawaii, found that unmanured cane was higher in purity than manured cane. Harrison and Bovel,¹⁰ of Barbados, say that they have no definite information as to the specific effect of the different mineral constituents of fertilizers on the saccharine content of the cane. While Geerligs is in the same position, Deerr believes that cane manuring affects the tonnage of the cane rather than its saccharine content.

⁹ Deerr, Noel, Cane Sugar (1911).

¹⁰ Ibid.

Table V indicates that the different fertilizers and combinations used had a varying effect on the yield of cane per hectare. Plots 3 and 5, the first fertilized with dried blood and the second with sulphate of potash alone, gave yields less than either check. The rest of the fertilized plots show an increase over the average yield of the controls. Plot 2 fertilized with lime alone and plot 12 fertilized with nitrate of soda and sulphate of ammonia are above plot 1 and below plot 9, which are the two control plots. All the others are above either control. These observations can be best understood with the aid of curve 1, fig. 2.

A table is given to show the relation between the yield of each plot in tons of cane and the yield calculated as 96° sugar per hectare. It is very interesting to note that while the plots

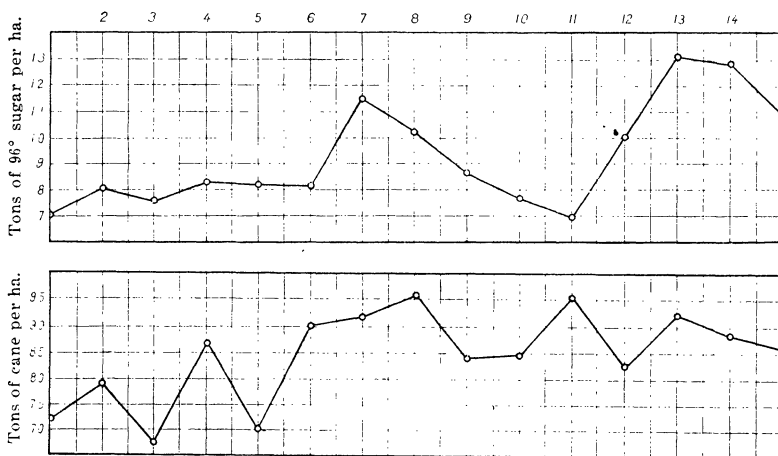

FIG. 2. Curve 1, effect of fertilizers on the yield of 96° sugar; curve 2, tonnage of cane per hectare.

from 1 to 6 and 9 to 11 show noticeable differences in the yield of cane per hectare, when compared as to their yield as 96° sugar, they show hardly any difference at all. Plots 7 and 8 show a decided increase over the control both in yield of cane and 96° sugar per hectare. While plot 12 is below control plot 9 in the yield of cane per hectare, it is above it in the yield of 96° sugar per hectare. Plots 13 and 14 gave almost the same yield of 96° sugar per hectare, and their yields are the highest obtained in these experiments. They are, however, below plots 8 and 11 in the yield of cane per hectare. Curve 2, fig. 2, shows the above observation plainly.

TABLE VI.—Relation between yield of each plot in tons of cane and yield calculated as 96° sugar per hectare.

Plot.	96° sugar from 100 tons cane.	Plot yield.		Hectare yield.		Gain or loss of sugar over average control.	Net price of sugar gained or lost per hectare.	Cost of fertilizing per hectare.	Gain or loss, due to application of fertilizers.
		Cane.	Sugar.	Cane.	Sugar.				
	Tons.	Kilos.	Kilos.	Tons.	Tons.	Tons.	Pesos.	Pesos.	Pesos.
1	9.82	3,233	317.48	71.84	7.05	0.0	0.0	0.0	0.0
2	10.27	3,535	363.04	78.55	8.06	0.22	33.44	20.28	13.16
3	11.25	3,035	341.50	67.44	7.59	-0.25	-38.00	34.10	-72.10
4	9.60	3,889	373.34	86.42	8.29	0.45	68.40	64.44	1.99
5	11.72	3,156	370.00	70.13	8.22	0.38	59.76	75.96	-16.20
6	9.81	4,043	397.00	89.84	8.20	0.36	55.00	75.96	-20.96
7	12.50	4,128	516.00	91.73	11.48	3.64	550.00	75.96	474.04
8	10.70	4,310	461.17	95.77	10.24	2.40	364.80	144.58	140.40
9	10.30	3,769	388.10	83.75	8.63	0.0	0.0	0.0	0.0
10	9.00	3,813	344.17	84.42	7.62	-0.22	-33.44	134.80	-168.24
11	7.24	4,288	313.00	95.29	6.90	-0.94	-143.00	144.36	-287.36
12	12.15	3,710	450.10	82.44	10.02	2.18	332.00	149.14	182.86
13	14.21	4,142	588.00	92.04	13.08	5.24	795.00	280.41	514.59
14	14.43	3,951	575.80	88.46	12.79	4.95	753.00	219.78	533.22
15	12.25	3,861	486.67	85.80	10.81	2.97	451.44	216.78	234.66

Table VI also shows which of the plots would produce the greatest returns. It is evident, judging from the results of these experiments, that the application of lime (plot 2), of a combination of sulphate of potash and double superphosphate (plot 7), of sulphate of ammonia and sulphate of potash (plot 8), of nitrate of soda and sulphate of ammonia (plot 12), of sulphate of ammonia, sulphate of potash, and double superphosphate with a subsequent application of nitrate of soda (plot 13), of sulphate of potash, nitrate of soda, and double superphosphate (plot 14), or of sulphate of ammonia, sulphate of potash, and double superphosphate (plot 15) will all more than pay for the cost of fertilizers and of their application. Plot 14 would give the highest return, although it is below plot 13 in the amount of 96° sugar that it would be possible to produce per hectare. This fact shows that it is better to use nitrate of soda at the very start than to use two forms of nitrogen in the combination. The superiority of nitrate of soda to sulphate of ammonia as a source of nitrogen for cane is indicated by a comparison of plots 13, 14, and 15.

CONCLUSIONS

1. Sulphate of potash alone and a complete fertilizer with nitrogen in the form of nitrate of soda gave the highest purity in the juice. Double superphosphate in combination with either

form of nitrogen lowered the purity of the juice to a large extent.

2. The effect of fertilizers on the percentage of sucrose in the cane runs parallel with that on the purity of the juice, although it is more pronounced in the latter than in the former.

3. Sulphate of ammonia in combination with sulphate of potash or with double superphosphate produced the greatest yield of cane. Dried blood and sulphate of potash apparently lowered the yield of cane.

4. Increased yield in tons of cane per hectare does not necessarily mean increased production of 96° sugar.

5. The complete fertilizer with nitrogen in the form of nitrate of soda would give the highest return in pesos and centavos if used on this soil.

6. It is not claimed that the results of these experiments will be directly applicable even at separated points near the college, and it is doubtful whether the same results would be obtained if the fertilizers used were tried on a different field in the college itself. However, it is concluded that the complete fertilizer with nitrogen in the form of nitrate of soda would in all probability give good results on an ordinary soil.

ILLUSTRATIONS

TEXT FIGURES

- FIG. 1. *Curve 1*, effect of fertilizers on the purity of juice; *curve 2*, sucrose content of the cane.
2. *Curve 1*, effect of fertilizers on the yield of 96° sugar; *curve 2*, tonnage of cane per hectare.



VOL. XIII, SEC. A, No. 4

JULY, 1918

THE PHILIPPINE
JOURNAL OF SCIENCE

ALVIN J. COX, M. A., PH. D.
GENERAL EDITOR

SECTION A
CHEMICAL AND GEOLOGICAL SCIENCES
AND THE INDUSTRIES

EDITED WITH THE COÖPERATION OF

H. C. BRILL, PH. D.; J. R. WRIGHT, PH. D.; G. W. HEISE, M. S.
T. DAR JUAN, A. B., PH. D.; A. H. WELLS, A. B.
R. C. MCGREGOR, A. B.; H. E. KUPFER, A. B.

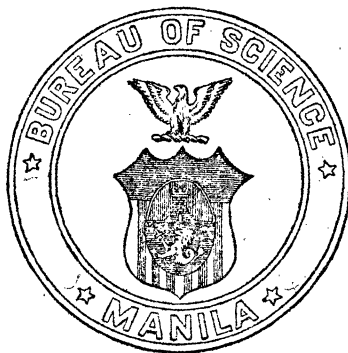

PHILIPPINE JOURNAL OF SCIENCE

A TEN-YEAR INDEX

CONTENTS AND INDEX OF THE PHILIPPINE JOURNAL OF SCIENCE, VOLUME I (1906) TO VOLUME X (1915)

Order No. 449. Bureau of Science Publication No. 8. Paper, 441 pages.
Price \$2, United States currency, postpaid.

One copy of this index has been sent free of charge to each subscriber that has received Volumes XI and XII of the Journal.

This publication consists of:

The complete contents of the first ten volumes of the Philippine Journal of Science, all sections; giving all authors, titles of articles, and page numbers. The exact date of issue of each number is recorded.

An author index, being an alphabetical list of all the contributors. The titles of all the articles are listed under the names of their respective authors.

A subject index. The subject matter is very fully indexed by catch words from the titles, by geographical localities, and by subjects. All systematic names in zoölogy and botany, as well as the thousands of English and local names, are entered in the index.

STUDIES IN PHILIPPINE DIPTERA, II

By M. BEZZI

Order No. 437. Bureau of Science Publication No. 10. Paper, 59 pages and 1 plate.
Price \$0.50, United States currency, postpaid.

This is the second century of Professor Bezzi's enumeration of Philippine species of flies and includes descriptions of new genera and new species.

PLEASE GIVE ORDER NUMBER

Orders for Bureau of Science publications may be sent to the BUSINESS MANAGER, Philippine Journal of Science, Bureau of Science, Manila, P. I., or to any of the following agents:

AGENTS

THE MACMILLAN COMPANY, 64-66 Fifth Avenue, New York, U. S. A.
WM. WESLEY & SON, 28 Essex Street, Strand, London, W. C., England.
MARTINUS NIJHOFF, Lange Voorhout 9, The Hague, Holland.
KELLY & WALSH, Limited, 32 Raffles Place, Singapore, Straits Settlements.
A. M. & J. FERGUSON, 19 Baillie Street, Colombo, Ceylon.
THACKER, SPINK & Co., P. O. Box 54, Calcutta, India.

THE PHILIPPINE JOURNAL OF SCIENCE

A. CHEMICAL AND GEOLOGICAL SCIENCES
AND THE INDUSTRIES

VOL. XIII

JULY, 1918

No. 4

THE SOLUBILITY OF PORTLAND CEMENT AND ITS RELATION TO THEORIES OF HYDRATION ¹

By J. C. WITT and F. D. REYES

(From the Laboratory of General, Inorganic, and Physical Chemistry,
Bureau of Science, Manila, P. I.)

ONE TEXT FIGURE

In connection with some previous work in this laboratory,² occasion arose to treat a few grams of cement with a solution of sodium sulphide and then to filter, wash, and examine the filtrate. It was found impossible to wash the residue free from soluble calcium compounds, for the wash water invariably showed a test for that element. Moreover only a portion of the calcium compounds dissolved came through the filter, because calcium carbonate was formed from contact with the air. The same behavior was noted when water was substituted for the sulphide solution. It was found that many times the original quantity of water could be added without resulting in a residue free from soluble calcium compounds. This suggested an investigation to determine just what constituents of cement will go into solution and the proportion of the total amount of each present in the sample. A review of the literature revealed that, while a number of writers mentioned the solubility of constituents in water, there were few reliable quantitative data available.³

It is common experience that water in which cement test pieces are stored soon contains substances in solution. It becomes soapy to the touch and has an alkaline reaction, and a qualitative test will reveal the presence of the calcium ion. That calcium hydroxide is among the products of the hydration of cement.

¹ Received for publication April 10, 1918.

² Witt, J. C., *This Journal*, Sec. A (1916), 11, 273.

³ Compare, however, Winkler, A., *Journ. prakt. Chem.* (1856), 67, 444.

has been well established. Le Chatelier⁴ observed crystals of calcium hydroxide in examining sections cut from hardened cement specimens. Winkler⁵ says that cement is hydrolyzed into free lime and some compounds of lime, silica, and alumina. Stern⁶ found that calcium aluminates were decomposed by water, forming gelatinous alumina and calcium hydroxide. Reed⁷ made some interesting microscopic studies of hydrated cement. He says:

When Portland cement is gauged with water, lime goes into solution and a thin skin of calcium carbonate is formed on the moist surface which protects the interior mass more or less completely from the action of the air.

His method is to treat cement with water on a microscope slide and then to protect the mixture from the air by paraffin. Two kinds of crystals are formed—calcium aluminate and calcium sulphaluminate. Hart⁸ mixed cement with water and then filtered rapidly. The filtrate contained sulphates, silicates, free lime, and caustic alkali. On letting a fresh mixture stand two and one-half hours and then filtering and examining the filtrate, he found the chief constituent to be potassium sulphate, which he concluded was formed by the double decomposition of the soluble potassium compounds and the calcium sulphate present.

PRELIMINARY WORK

The term solubility as employed in this paper signifies the mass dissolved per gram of cement present in the system under given conditions and not the mass dissolved by a unit weight of water—as in most solubility measurements. The proportion of water has been kept considerably in excess of the amount necessary, and no effort was made to keep the temperature constant. All the experiments were made at room temperature in Manila, which averages about 28° to 30° C. The factors that influence the results have been found to be fineness of grain, quantity of water present, absence of carbon dioxide, method of agitation, and time.

Four brands of cement, which we shall designate as I, II, III, and IV. were used in the work. The analyses are shown in Table I.

⁴ Cf. West, C. H., *The Chemistry and Testing of Cement.* London, Edward Arnold (1911), 113.

⁵ Loc. cit.

⁶ Stern, E., *Chem. Zeitg.* (1908), 32, 1029.

⁷ Reed, E. J., *Journ. Soc. Chem. Ind.* (1910), 29, 735.

⁸ Hart, *Tonind. Zeitg.* (1908), 32, 754. [*Journ. Soc. Chem. Ind.* (1908), 27, 568.]

TABLE I.—*Analyses of cements.*

[Numbers indicate percentages.]

	Brand.			
	I.	II.	III.	IV.
Loss on ignition	2.43	2.15	2.17	3.24
Silica (SiO ₂)	22.60	21.40	21.26	20.62
Alumina (Al ₂ O ₃)	7.72	7.58	8.54	6.62
Ferric oxide (Fe ₂ O ₃)	1.76	1.70	2.08	2.56
Calcium oxide (CaO)	61.32	62.94	62.82	63.50
Magnesia (MgO)	1.08	1.37	1.13	1.43
Sulphuric anhydride (SO ₃)	1.45	1.61	1.02	0.82
Sodium and potassium oxides (Na ₂ O, K ₂ O)	1.63	1.14	1.17	1.33

Five hundred cubic centimeters of water were placed in each of four 800 cubic centimeter Erlenmeyer flasks, fitted with a rubber stopper with two holes. Through one of these holes was inserted a reflux condenser; the other carried a glass tube bent at right angles, the end of which projected beneath the surface of the water. The water was boiled for an hour or two by means of a Bunsen burner, until all the dissolved gases were expelled. The flame was then removed, and a current of air free from carbon dioxide⁹ was passed through the tube into the liquid, until the flask and contents had assumed room temperature. In the meantime two grams of cement were weighed into a small glass bulb. While the current of air was still passing, this bulb was dropped into a flask. The two-hole stopper was replaced with a solid stopper and the contents vigorously shaken to prevent the cement from caking. The flask was then placed in a mechanical shaker and vigorously agitated for twenty hours. Of the several types of shakers available for this work, the most satisfactory may be described as follows: A small platform was mounted on grooved wheels, which were supported by a small track. This platform was rapidly driven back and forth by a crank shaft, having a stroke of about 12 centimeters. The flasks were clamped in a horizontal, longitudinal position. The flask was then removed and allowed to stand for twenty-four hours, when the solid matter completely settled, leaving a clear supernatant liquid. The stopper was partly removed, and the tube was inserted in the neck of the flask, through which a

⁹ The air was passed through two wash bottles containing potassium hydroxide solution and then through one containing barium hydroxide solution. The last named acted as an indicator. If a trace of carbon dioxide escaped from the first two bottles, it was caught in the third and produced a turbidity. The contents of all of the bottles were then changed.

current of air free from carbon dioxide was passed. A pipette was then inserted, and portions were withdrawn for analyses.

The solids in the bottom of each flask consisted of two layers. The upper was white and flocculent, consisting partly of aluminium hydroxide. The lower was much larger and evidently consisted partly of cement which had not been decomposed by the action of the water. Analysis of the supernatant liquid showed it contained in solution considerable calcium, a trace of iron and aluminium, and no silica. The shaking was repeated for another period to see if any more calcium went into solution. Analysis showed there was an appreciable increase. This was repeated until the flasks had been shaken for a total of four hundred twenty-six hours. Numbers II and IV had become constant, and number I practically so, but number III still showed a gain. The lower layer of solid in the flask had almost entirely disappeared, only a few particles remaining. During the experiment it was necessary to add more water from time to time to keep the solution from reaching saturation. It was decided to stop the work at this point and start a new series after making a number of changes that the work had suggested. The results of the first series of tests are given in Table II. It will be noted that from 35 to 38 per cent of the total calcium of each cement went into solution.

TABLE II.—*First series. Calcium dissolved from original cements during various periods of shaking with carbon dioxide free water.*

[Numbers indicate weight of calcium, in grams, per gram of cement.]

	Brand.			
	I.	II.	III.	IV.
Total calcium (Ca) in cement	0.4383	0.4499	0.4490	0.4539
Calcium (Ca) dissolved during each period:				
First period, 20 hours	0.0665	0.0808	0.0843	0.0681
Second period, 16 hours	0.0071	0.0125	0.0089	0.0259
Third period, 20 hours	0.0129	0.0245	0.0172
Fourth period, 40 hours	0.0086	0.0114	0.0115	*0.0288
Fifth period, 55 hours	0.0168	0.0130	0.0114	0.0129
Sixth period, 48 hours	0.0255	0.0208	0.0138	0.0184
Seventh period, 22 hours	0.0071	0.0038	0.0063	0.0053
Eighth period, 41 hours	0.0106	0.0066	0.0052	0.0000
Ninth period, 54 hours	0.0032	0.0007	0.0010
Tenth period, 45 hours	0.0041	0.0000	0.0029
Eleventh period, 65 hours	0.0020	0.0104
Total, 426 hours	0.1644	0.1741	0.1729	0.1594
Total calcium dissolved (per cent)	37.51	38.69	38.50	35.12

* This value represents the amount dissolved during both third and fourth periods.

MANIPULATION

Since it was likely that the larger particles of cement were the last to be affected by the water, these were eliminated before starting the second series. An air separator essentially similar to the Goreham flourometer¹⁰ was utilized. No attempt was made to obtain quantitative results nor to measure the size of grain. The air pressure corresponded to 20 millimeters of mercury. The air was passed through suitable solutions to remove both moisture and carbon dioxide, before coming into contact with the cement. Since cement dust is likely to be slightly different in chemical composition from the original cement after such a separation, the cements were again analyzed, with the results shown in Table III. All the work hereafter described was done with this material.

TABLE III.—*Analyses of cements after air separation.*

[Numbers indicate percentages.]

	Brand.			
	I.	II.	III.	IV.
Loss on ignition	3.91	3.73	3.55	5.00
Silica (SiO ₂)	20.48	20.22	18.96	18.40
Alumina (Al ₂ O ₃)	7.81	7.17	9.58	8.95
Iron oxide (Fe ₂ O ₃)	2.37	2.11	2.32	2.03
Calcium oxide (CaO)	61.14	62.38	61.84	62.20
Magnesia (MgO)	1.22	1.30	1.42	1.34
Sodium and potassium oxides (Na ₂ O, K ₂ O)	1.07	0.64	0.63	0.87
Sulphuric anhydride (SO ₃)	1.97	2.43	1.62	1.27

Some other changes also were found advisable before starting the next series of determinations. It was found that the Erlenmeyer flasks did not stand the continued rough usage in the shaking machines. It was also desirable to increase the actual amount of water for each experiment as well as the quantity per gram of cement. Therefore the new manipulation was as follows:

A 20-liter bottle was filled with water free from carbon dioxide and protected by a soda-lime bulb. A special automatic pipette was made with an approximate capacity of 850 cubic centimeters. When this was standardized, it was found to deliver 863.5 cubic centimeters. This value was constant and was sufficiently close to the desired volume, so it was not changed. The pipette was mounted and then connected with a siphon in the 20-liter bottle.

¹⁰ Cf. *Tech. Paper, U. S. Bur. Standards* (1915), No. 48, 8.

The air inlet was protected by a soda-lime bulb, so that the water could be easily and quickly measured and delivered without exposure to carbon dioxide. Narrow-mouthed glass-stoppered bottles were substituted for the Erlenmeyers.

To start one of the new series of experiments, it was only necessary to wash out a bottle with air free from carbon dioxide, place therein a pipetteful of water, and quickly add a glass capsule of cement previously weighed. Only a trace of carbon dioxide was present in the system. For each gram of cement, 431.75 cubic centimeters of water were present. At 30° C. 400 grams of water are sufficient to dissolve 0.612 gram calcium hydroxide,¹¹ which is equivalent to 0.462 gram calcium oxide, or 74.06 per cent of the total calcium oxide in the cement containing the most calcium oxide. As will be shown later, the highest percentage of calcium going into solution in this series was 40.89 per cent.

Table IV shows the calcium in solution for each sample of fine cement during fifteen days' shaking, or until each sample had reached a constant value.

TABLE IV.—*Second series. Calcium dissolved from fine cement by shaking with carbon dioxide free water.*^a

	Brand.			
	I.	II.	III.	IV.
	g.	g.	g.	g.
Total calcium (Ca) present per gram of cement	0.4369	0.4458	0.4419	0.4445
Calcium (Ca) dissolved per gram of cement:				
First period, 1 day	0.1282	0.1432	0.1519	0.1535
Second period, 1 day	0.0072	0.0147	0.0091	0.0113
Third period, 2 days	0.0073	0.0131	0.0076	0.0025
Fourth period, 2 days	0.0034	0.0056	0.0018	0.0038
Fifth period, 2 days	0.0058	0.0013	0.0014	0.0017
Sixth period, 2 days	0.0104	0.0026	0.0031	0.0031
Seventh period, 5 days	0.0041	0.0000	0.0000	0.0000
Total, 15 days	0.1664	0.1805	0.1749	0.1759
Percentage of total calcium that goes into solution	38.09	40.49	39.58	39.57

^a At the end of the sixth period three of the cements showed constant results. At the end of the seventh period the other one was constant. The total $\text{Ca}(\text{OH})_2$ in solution at the end of the operation was well below the saturation point, showing that the constant value was not due to a saturated solution.

The main difference between this series and the first is the much greater amount of calcium going into solution during the

¹¹ Seidel, Atherton, Solubilities of Inorganic and Organic Substances. D. van Nostrand Co., New York (1907), 99.

first period—about double. The time necessary for completion was shorter, and the percentage of the total calcium present was higher.

The total amounts of other elements in solution are negligible in comparison with the calcium. The complete analysis of the liquid after twenty-four hours of shaking is shown in Table V. The first column under each number shows the amount of each constituent dissolved per gram of cement. The second column shows the percentage of the total amount of each constituent in solution (compare with Table III).

TABLE V.—*The weight of each constituent (per gram of cement) that goes into solution during the first twenty-four hours. Also the percentage of the total amount of each constituent present that is dissolved.*

	Brand.							
	I.		II.		III.		IV.	
	<i>g.</i>	<i>P. ct.</i>	<i>g.</i>	<i>P. ct.</i>	<i>g.</i>	<i>P. ct.</i>	<i>g.</i>	<i>P. ct.</i>
Silica (SiO ₂)	trace		trace		trace		trace	
Iron and aluminium oxides (Fe ₂ O ₃ , Al ₂ O ₃)	0.0088	8.64	0.0065	7.00	0.0037	3.11	0.0064	5.82
Calcium oxide (CaO)	0.1797	29.39	0.1998	32.03	0.2135	34.51	0.2147	34.52
Magnesium oxide (MgO)	trace		trace		trace		trace	
Sodium and potassium oxides (Na ₂ O, K ₂ O)	0.0045	42.06	0.0041	64.06	0.0044	69.84	0.0057	65.52
Sulphuric anhydride (SO ₃)	0.0131	66.50	0.0183	75.31	0.0111	68.52	0.0096	75.59

There is no important increase in the amounts of these constituents in solution after the first period of shaking. The percentage of each constituent in solution is interesting. We should not expect to find any soluble silicates under these conditions, and the small amount of iron, aluminium and magnesium in solution is not surprising when such a large concentration of calcium hydroxide is present. The absence of magnesium may be partly due to the slowness with which magnesium compounds hydrate. The slight solubility of calcium sulphaluminate explains the small amount found in solution.

After the series of experiments had reached completion, and no further calcium went into solution, the precipitate remaining in each flask was collected and washed. (It was not possible to wash completely free from soluble calcium compounds.) The residues were then analyzed as a check on the analyses of the soluble portion. In Table VI the first line shows the loss on ignition, after the material had been dried to constant weight at 110° C. The other results were calculated to the after-ignition basis, in order that they might be more comparable with the cement before water was added.

TABLE VI.—Analyses of residue after completion of solubility determinations.

[Numbers indicate percentages.]

	Brand.			
	I.	II.	III.	IV.
Loss on ignition	25.52	28.64	25.26	26.24
Silica (SiO ₂)	35.56	34.57	32.36	33.10
Alumina (Al ₂ O ₃)	14.26	13.40	10.30	10.12
Iron oxide (Fe ₂ O ₃)	2.36	3.17	5.16	4.80
Calcium oxide (CaO)	45.12	45.45	49.00	48.90
Magnesium oxide (MgO)	1.86	2.65	2.20	2.27
Sulphuric anhydride (SO ₃)	0.35	0.18	0.53	0.25
Sodium and potassium oxides (Na ₂ O, K ₂ O)	0.44	0.50	0.32	0.54

Comparing this with Table III it may be noted that the removal of calcium by solution has considerably raised the percentage of aluminium, silica, and magnesium in the residue. The percentage of iron remains about the same, but the percentage of sulphuric anhydride and alkalis is less because of the high percentage of each of these going into solution.

The next point investigated was the effect of a larger volume of water per gram of cement. Would this affect speed of solution or the final quantity of constituents in solution? The same volume of water was taken in each case, but less cement—2, 1, 0.5, 0.25, 0.1 gram, respectively. The volume of water present per gram of cement was then calculated and, neglecting the decimals, the values are shown in Table VII.

TABLE VII.—Effect of the volume of water on velocity of solution and total amount of calcium dissolved in twenty-four hours.^a

Volume of water per gram of cement.	I.		II.		III.		IV.		Time required for constant results.
	<i>g.</i>	<i>Per cent.</i>	<i>g.</i>	<i>Per cent.</i>	<i>g.</i>	<i>Per cent.</i>	<i>g.</i>	<i>Per cent.</i>	
432	0.1282	29.34	0.1432	32.12	0.1519	34.37	0.1535	34.52	12
864	0.1537	35.14	0.1857	41.63	0.1816	41.07	0.1816	40.84	12
1,727	0.1993	45.60	0.2407	53.96	0.2444	55.27	0.2334	52.48	1
3,454	0.2707	61.92	0.2934	65.79	0.2934	66.36	0.2690	60.48	1
8,635	0.4038	92.41	0.3907	87.68	0.4038	91.36	0.3855	86.65	1

^a The first column under each number shows calcium dissolved per gram of cement; the second shows the percentage dissolved of the total calcium present (in 1 gram of cement). With 432 and 864 cubic centimeters of water, respectively, the solution continued to increase for a number of days, but with the other three volumes, the results were constant after the first twenty-four hours.

Table VII shows that from 87 to 92 per cent of the calcium in a cement will go into solution in twenty-four hours, provided the volume of water present is sufficiently large. Further it seems probable that all of the calcium would dissolve if a still greater volume were used, providing the cement were sufficiently fine and the last trace of carbon dioxide had been removed both from the cement and from the water. We can now see why such results as those of Hart¹² are misleading. Both the potassium and the sulphate ion may be found in solution, but, in place of being the chief constituent, they are negligible in quantity as compared with the calcium.

On plotting the percentage calcium dissolved against the volume of water present for each cement in Table VII, it may be

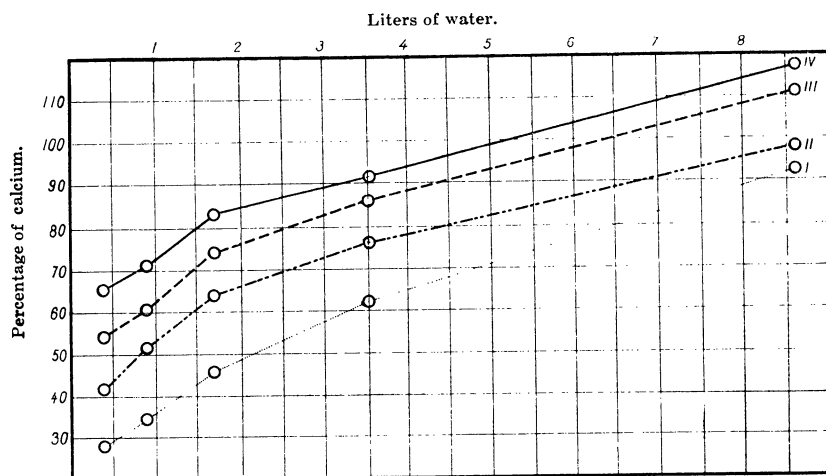

FIG. 1. Percentage of calcium dissolved in relation to volume of water present. In order to facilitate comparison, curve II is drawn 10 points above its true position; III, 20 points; and IV, 30 points.

seen that the curves agree very closely (fig. 1). This is somewhat surprising in that all the cements are of different manufacture. It will be noted on comparing Tables III and VII that the two cements having the highest percentage of calcium in solution are lowest in calcium. There seems to be no relation between the percentage solubility and the amounts of other constituents present.

INTERPRETATION OF THE RESULTS IN TERMS OF VARIOUS THEORIES OF HYDRATION

Unquestionably the most important recent advances in our knowledge of the constitution of cement have been accomplished

¹² Loc. cit.

by methods of microscopy and physical chemistry. However, we believe that the usefulness of methods of analytical chemistry has not been exhausted in this field and that such methods still offer points for attacking these problems, either alone or in conjunction with other methods. Although this work was undertaken simply with the object of learning what constituents of cement would dissolve in water under favorable conditions—and in what quantities—the results obtained are closely related to hydration phenomena. The amount of calcium hydroxide found in solution in presence of varying volumes of water can be hardly explained by the laws of solubility. The solution never reaches the point of saturation. This cannot be due to the other substances in solution, because the amounts are relatively too small. The nature of the solvent, the method of agitation, the kind of solute, and the temperature (within certain limits) all have been kept constant. Therefore the determining factor is evidently the formation of calcium hydroxide, by the hydration of the various compounds present in cement. Or it is the inhibition of hydration caused by calcium hydroxide in solution. This effect may be said to be twofold. It diminishes the speed of hydration and also the total amount of hydration possible under given conditions. Or, the speed of hydration is diminished until the amount taking place in twenty-four hours is too small to be detected by the methods of analysis employed.

The conditions under which cement is hydrated in this work are, of course, abnormal, as compared with conditions in practice. This comes about through the use of a large volume of water and through agitation, which keeps the granules separated and keeps a large surface exposed to the water. The exclusion of carbon dioxide probably does not constitute such a great variation from normal conditions as at first appears. Over the surface of newly placed concrete or mortar, a thin film of calcium carbonate forms almost immediately, and this protects the interior from further contact with this gas. Keeping these facts in mind, let us now try to interpret the results in terms of results that have been obtained by various investigators of the question of hydration of cement. In general, the agreement is striking, though there are some important differences. It may be also stated that not sufficient work has been done along these lines to justify the formulation of any new theory of hydration.

The theory of Richardson¹³ is that—

On addition of water to the stable system made up of the solid solu-

¹³ Cf. Meade, Richard K., *Portland Cement*. The Chemical Publishing Co., Easton, Pa. (1911), 22.

tions which compose Portland cement, a new component is introduced, which immediately results in lack of equilibrium, which is only brought about again by the liberation of free lime. This free lime the moment that it is liberated is in solution in the water, but owing to the rapidity with which it is liberated from the aluminate, the water soon becomes supersaturated with calcic hydrate and the latter crystallizes out in a network of crystals, which binds the particles of undecomposed Portland cement together.

The results of the present work show that one of the products of hydration is undoubtedly calcium hydroxide and that the water present contains some of it in solution. Further it is well established that crystals of this compound are found in hardened cement. There is a question, however, whether or not these crystals are as important as the writer intimates and also as to the mechanism of their formation. Considering the amount of water that is ordinarily mixed with cement and the low solubility of calcium hydroxide, it is evident that if at a given instant all the water were saturated with this compound, and then all the calcium hydroxide should crystallize out, the percentage of the total calcium in the cement so affected would be small. For example, let us consider that one kilogram of cement is mixed with sufficient water to produce a paste of normal consistency. The average amount of water required is from 20 to 25 per cent of the weight, or say 250 cubic centimeters. Now cement will contain on an average of 62 per cent calcium oxide, or 620 grams—which is equivalent to approximately 819 grams of calcium hydroxide—per kilogram. Disregarding the portion of the water that enters into combination with calcium oxide and is unavailable for other reasons, the 250 cubic centimeters present would dissolve only 0.41 gram of the solid at a temperature of 20° C. according to Seidel.¹⁴ This is, of course, on the assumption made previously that the relative amounts of other substances in solution are not sufficient materially to affect the solubility of calcium hydroxide. It can be seen that this amount of the substance is not sufficient to bind the cement together.

It is possible to consider that the crystallization occurs progressively, that is, when the solution becomes saturated, some of the dissolved hydroxide crystallizes out, more goes into solution as a result of further hydration, and so on. However, a number of facts are opposed to such a view. If the water is not saturated at a given time, and crystals of calcium hydroxide are present, it is more likely that some of these would dissolve than

¹⁴ Loc. cit.

that more of the calcium compounds in the cement would be hydrated. This is on the basis of the results presented in this paper, which show that the presence of calcium hydroxide in solution tends to inhibit further hydration. Further, it is known that if an imperfect crystal is suspended in a saturated solution of the same substance, it does not change in weight, though it may change in form sufficiently to become again regular.

The principal components of cement are compounds of calcium with aluminium and of calcium with silicon. Indeed, according to Rankin:¹⁵

Microscopical examination of commercial Portland cement clinker shows it to be made up largely (over 90 per cent) of the three compounds, $2\text{CaO} \cdot \text{SiO}_2$, $3\text{CaO} \cdot \text{SiO}_2$ and $3\text{CaO} \cdot \text{Al}_2\text{O}_3$. It would therefore appear that the value of Portland cement as a cementing material when mixed with water is largely due to one or more of these compounds.

Now since about 90 per cent of the total calcium in a cement is found in solution after treating with water under given conditions, with indications that still more could be dissolved, it follows that (1) all the important compounds may be rapidly hydrated under favorable conditions and that (2) one product of the hydration is always calcium hydroxide.

The colloid theory for the setting of cement was advanced by Michaelis.¹⁶ His idea is that the most important step is the formation of a gelatinous mass containing calcium oxide, silica, and water. Later this colloid dries and hardens, and to it is due the principal strength of the cement. Considerable work has been done by others on the basis of this theory, using cement itself or one of the calcium aluminates.

Schott¹⁷ and Keiserman¹⁸ found that, when certain calcium aluminates are hydrated, aluminium hydroxide is split off. Stern¹⁹ found that aluminates were decomposed by water forming the hydroxide of calcium and aluminium. Later he dialyzed the filtrate and found that calcium passed the membrane, but with only a trace of aluminium. Klein and Phillips²⁰ repeated the work of Stern, taking great care to exclude carbon dioxide during the operation. They used tricalcium aluminate and found

¹⁵ Rankin, George A., *Journ. Franklin Inst.* (1916), 181, 770.

¹⁶ Michaelis, W., *Cement & Eng. News* (1909), 21, 298, 338.

¹⁷ Schott, O., *ibid.* (1910), 22, 515.

¹⁸ Keiserman, *ibid.* (1911), 23, 10.

¹⁹ Stern, E., *loc. cit.*

²⁰ Klein, A. A., and Phillips, A. J., *Tech. Paper, U. S. Bur. Standards*, (1914), No. 43, 18.

that the liquid passing the membrane contained aluminium and calcium in about the original proportions. They conclude from this that no colloid is formed and that the substance is not broken up by hydration.

The work in this laboratory favors Stern's results, though it must be remembered that commercial cement was used in every case and not an aluminate alone. It may be also said that if a colloid forms according to Michaelis's theory it is broken up by a large excess of water, as the presence of such a large amount of dissolved calcium with only a trace of silicon (in any form) shows. Or the explanation may be that the colloid does not form because the concentration of the calcium hydroxide solution is not sufficiently high.²¹

It is generally conceded by cement investigators that the strength of a test specimen depends to some extent on the fineness of grinding; in fact there is no doubt that, other factors being equal, the finer a cement is ground the greater strength it will give mortar briquettes. A proof of this is that if specimens of hardened mortar or paste are reground the powder may be again mixed with water, and a fair degree of strength obtained.²² The mass may be again ground, and water added, with a like result. The usual explanation offered for this is that during the first gauging the water cannot penetrate the larger particles of cement and that the cores of these remain unchanged. When reground and regauged, these parts become active, and there is sufficient new paste to cement the whole together and so on. The present work supports this explanation, but indicates that there are other factors to be considered. By referring to Tables IV and VII it may be seen that, although only about 40 per cent of the total calcium in the cements was hydrated and dissolved when agitated for fifteen days in the original experiment with fine cement, approximately 90 per cent of the calcium went into solution in only twenty-four hours, when the relative volume of water was increased twentyfold. Since the cement was of the same fineness in both cases, it may be seen that the volume of water is of importance as well as the size of the particles. Further it is probable that if the finest cement flour obtainable were gauged with water it would not be completely hydrated—not because of size of grain, but because of reasons already ex-

²¹ Michaelis, loc. cit.

²² Michaelis, loc. cit.

plained—and that if this material after hardening were reground another set could be obtained.

This leads us to the conclusion that the presence of more water when cement is gauged facilitates hydration and should, therefore, result in greater strength. This last is contrary to the general opinion on the subject. As a rule, especially for short periods, the addition of more water means lower strength²³ for briquettes. In concrete practice, very wet mixes are not recommended.²⁴

Here again are other factors to be considered. The water that remains mixed with the concrete or mortar until setting is complete reduces the strength, because it decreases the density of the material and consequently the cohesion. The water that separates, either by leaking through the forms or rising to the top, carries calcium hydroxide, one of the products of hydration, in solution. Previous work by one of us²⁵ has indicated that an agency that removes dissolved calcium hydroxide or interferes with the cohesion will lower the strength. Therefore we believe that, although the strength is increased by the use of a higher percentage of water, other factors have a still greater tendency to lower the strength, and consequently the latter is the net result. A series of experiments just started indicates that this conclusion is correct, although sufficient data have not been obtained to justify any definite statement as yet. A series of mortar briquettes was made with gradually increasing amounts of water, starting with the amount calculated from normal consistency tests. There was a decrease in strength with increase of water. A second series was made with the same amounts of water, but, before a given mix was molded, it was placed in a metal vessel, and the water was evaporated until the weight showed that the amount indicated by the normal consistency tests was reached. It was assumed that the extra water temporarily present would facilitate hydration and dissolve more calcium hydroxide and that this hydroxide would remain in solution even after a portion of the water was evaporated, because the solution was not near the saturation point, even though the solubility of this compound decreases with a rise in temperature. After the evaporation each mix was immediately regauged and placed in molds. In general, the strength increased as the water increased, contrary to the first series.

²³ Cf. Larned, E. S., *Proc. Am. Soc. Test. Mat.* (1903), 3, 401.

²⁴ Cf. Taylor and Thompson, *A Treatise on Concrete*. John Wiley and Sons, New York (1917), 251.

²⁵ Witt, J. C., *This Journal*, *Sec. A* (1916), 11, 288.

SUMMARY

When cement is shaken with water in a closed vessel large amounts of calcium with relatively small amounts of most of the other elements present go into solution.

The factors that effect the results have been found to be (a) absence of carbon dioxide, (b) method of agitation, (c) fineness of grain, (d) volume of water, and (e) time. Of these, volume of water is the most important. The effect of temperature has not been studied.

As the volume of water is increased, the amount of calcium going into solution in a given time increases rapidly. When cement is treated with approximately eight thousand times its weight of water, 90 per cent of the calcium present goes into solution in twenty-four hours, with indications that still more would dissolve in a greater volume.

Though the work was not undertaken as a study of hydration, the results obtained are closely related to the theories of hydration that have been formulated from time to time.

Since all the important compounds in cement contain calcium, and 90 per cent of all calcium present goes into solution, it may be stated that under favorable conditions the hydration of all important compounds results in the formation of calcium hydroxide.

It has not been found possible to obtain a saturated solution of calcium hydroxide by shaking cement in water. This may be due to the fact that presence of dissolved calcium hydroxide inhibits further hydration, or it may be that when the concentration of the calcium hydroxide solution reaches a certain value a colloid is formed, according to Michaelis' theory.

ILLUSTRATION

TEXT FIGURE

FIG. 1. Percentage of calcium dissolved in relation to volume of water present.

156254—2

163

PHILIPPINE ECONOMIC-PLANT DISEASES

By OTTO A. REINKING

(From the College of Agriculture, Los Baños)

TWENTY-TWO PLATES AND FORTY-THREE TEXT FIGURES

CONTENTS

- | | |
|-----------------------------------------------------------------------------------------------------------------------------------------------------------------------------------------------------------------------------------------------------------------------------------------------------------------------------------------------------------------------------------------------------------------------------------------------------------------------------------------------------------------------------------------------------------------------------------------------------------------------------------------------------------------------------------------------------------------------------------------------------------------------------------------------------------------------------------------------------------------------------------------------------------------------------------------------------------------------------------------------------------------------------------------------------------------------------------------------------------------------------------------------------------------------------------------------------------------------------------------------------------------------------------------------------------------------------------------------------------------------|-----------------------------------------------------------------------------------------------------------------------------------------------------------------------------------------------------------------------------------------------------------------------------------------------------------------------------------------------------------------------------------------------------------------------------------------------------------------------------------------------------------------------------------------------------------------------------------------------------------------------------------------------------------------------------------------------------------------------------------------------------------------------------------------------------------------------------------------------------------------------------------------------------------------------------------------------------------------------------------------------------------------------------------------------------------------------------------------------------------------------------------------------------------------------------------------------------------------------------------------------------------------------------------------------------------------------------------------------------------------------------------------------------------------------------------------------|
| <p><i>Ananas comosus</i> (Linn.) Merr. (<i>A. sativas</i> Schultes f.). Pine-apple.
 <i>Asterinella stuhlmanni</i> (Henn.) Theiss.
 <i>Diplodia ananassae</i> Sacc.
 <i>Lembosia bromeliacearum</i> Rehm.
 <i>Steirochaete ananassae</i> Sacc.
 <i>Andropogon sorghum</i> Linn. (<i>Sorghum vulgare</i> Pers.). Sorghums, kaffirs, milos.
 <i>Coniosporium sorghi</i> Sacc.
 <i>Didymosphaeria anisomera</i> Sacc.
 <i>Fumago vagans</i> Pers.
 <i>Helminthosporium caryopsidum</i> Sacc.
 <i>Phyllachora sorghi</i> v. Höhnel.
 <i>Puccinia purpurea</i> Cooke.
 Sooty mold.
 <i>Ustilago sorghi</i> (Lk.) Pass.
 <i>Annona muricata</i> Linn. Soursop, guanabano.
 <i>Phyllosticta insularum</i> Sacc.
 <i>Apium graveolens</i> Linn. Celery.
 <i>Cercospora apii</i> Fr.
 <i>Arachis hypogaea</i> Linn. Peanut, mani.
 <i>Sclerotium</i>.
 <i>Septogloeum arachidis</i> Rac.
 <i>Areca catechu</i> Linn. Bunga, betel palm.
 <i>Anthostomella arecae</i> Rehm.
 <i>Colletotrichum arecae</i> Syd.
 <i>Diplodia arecina</i> Sacc.
 <i>Elfvigia tornata</i> (Pers.) Murr.
 <i>Eutypella rehmaniana</i> (Henn. et Nym.) v. Höhnel.
 <i>Exosporium hypoxyloides</i> Syd.
 <i>Exosporium pulchellum</i> Sacc.
 <i>Gloeosporium catechu</i> Syd.</p> | <p><i>Areca catechu</i> Linn.—Continued.
 <i>Gloeosporium palmarum</i> Oud.
 <i>Guignardia arecae</i> Sacc.
 <i>Peroneutypella arecae</i> Syd.
 <i>Pestalozzia palmarum</i> Cooke.
 <i>Phellostroma hypoxyloides</i> Syd.
 <i>Phomopsis arecae</i> Syd.
 <i>Phomopsis palmicola</i> (Wint.) Sacc.
 <i>Zygosporium oscheoides</i> Mont.
 <i>Artocarpus communis</i> Forst. (<i>A. incisa</i> Linn. f.). Breadfruit.
 <i>Cercospora artocarpi</i> Syd.
 <i>Cycloderma depressum</i> Pat.
 <i>Diplodia artocarpi</i> Sacc.
 <i>Marchalia constellata</i> (B. et Br.) Sacc.
 <i>Rhizopus artocarpi</i> Rac.
 <i>Artocarpus integra</i> (Raderm.) Merr. (<i>A. integrifolia</i> Linn. f.). Jack fruit, nangca.
 <i>Dichotomella areolata</i> Sacc.
 <i>Diplodia artocarpina</i> Sacc.
 <i>Rhizopus artocarpi</i> Rac.
 <i>Beta vulgaris</i> Linn. Chard.
 <i>Cercospora</i>.
 <i>Brassica oleracea</i> Linn. Cabbage.
 <i>Pseudomonas campestris</i> (Pammel.) Erw. Smith.
 <i>Brassica pekinensis</i> (Lour.) Skeels, Pechay.
 <i>Cercospora armoraciae</i> Sacc.
 <i>Cercospora brassicicola</i> Henn.
 <i>Canavalia gladiata</i> DC., and <i>Canavalia ensiformis</i> DC. Horse beans, sword beans.
 <i>Cercospora canavaliae</i> Syd.
 <i>Didymium squamulosum</i> (Alb. et Schw.) Fr.
 <i>Elsinoe canavaliae</i> Rac.</p> |
|-----------------------------------------------------------------------------------------------------------------------------------------------------------------------------------------------------------------------------------------------------------------------------------------------------------------------------------------------------------------------------------------------------------------------------------------------------------------------------------------------------------------------------------------------------------------------------------------------------------------------------------------------------------------------------------------------------------------------------------------------------------------------------------------------------------------------------------------------------------------------------------------------------------------------------------------------------------------------------------------------------------------------------------------------------------------------------------------------------------------------------------------------------------------------------------------------------------------------------------------------------------------------------------------------------------------------------------------------------------------------|-----------------------------------------------------------------------------------------------------------------------------------------------------------------------------------------------------------------------------------------------------------------------------------------------------------------------------------------------------------------------------------------------------------------------------------------------------------------------------------------------------------------------------------------------------------------------------------------------------------------------------------------------------------------------------------------------------------------------------------------------------------------------------------------------------------------------------------------------------------------------------------------------------------------------------------------------------------------------------------------------------------------------------------------------------------------------------------------------------------------------------------------------------------------------------------------------------------------------------------------------------------------------------------------------------------------------------------------------------------------------------------------------------------------------------------------------|

- Canavalia gladiata* DC.—Continued.
Gloeosporium canavaliae Syd.
Physalospora guignardioides Sacc.
- Capsicum annuum* Linn. Red pepper.
Bacillus solanacearum Erw. Smith.
 Erysiphaceae.
Phomopsis capsici (Magnaghi) Sacc.
Vermicularia capsici Syd.
- Capsicum frutescens* Linn. Red pepper.
Vermicularia capsici Syd.
- Carica papaya* Linn. Papaya.
Aspergillus periconioides Sacc.
Colletotrichum papayae (Henn.) Syd.
Didymella caricae Tassi.
Diplodia caricae Sacc.
 Erysiphaceae.
Fusarium.
Fusarium heveae Henn.
Lasiodiplodia theobromae (Pat.) Griff. et Maubl.
Mycosphaerella caricae Syd.
Penicillium.
Phytophthora faberi Maubl.
Pythium debaryanum Hesse.
Rhizoctonia.
Rhizopus.
- Citrus* spp. Oranges, lemons, limes, pomelos.
 Bark rot.
 Chlorosis, nonparasitic.
 Die-back, lack of nutrition.
Pseudomonas citri Hasse.
Rhizoctonia.
- Citrus maxima* (Burm.) Merr. (*C. decumana* Linn.).
Aschersonia sclerotoides Henn. (On coccids.)
Colletotrichum gloeosporioides Penz.
Corticium salmonicolor Berk. et Broome.
Eutypella citricola Speg.
Eutypella heteracantha Sacc.
Gloeosporium intermedium Sacc. Gummosis.
Lasiodiplodia theobromae (Pat.) Griff. et Maubl.
- Citrus maxima* (Burm.) Merr.—Cont.
 Lichens.
Loranthus philippensis Cham. (Epiphytes.)
Meliola.
Micropeltis.
 Mottled leaf, nonparasitic.
Nectria episphaeria (Tode.) Fr.
Penicillium.
Phyllosticta circumsepta Sacc.
 Scaly bark.
 Spiny mold, imperfect fungus.
- Citrus nobilis* Lour.
Cytospora aberrans Sacc.
Diaporthe citrincola Rehm.
Diplodia aurantii Catt.
Eutypella citricola Speg.
Hypoxyton atropurpureum Fr. (On coccids.)
Massarina raimundoi Rehm.
Tryblidiella mindanaensis Henn.
Tryblidiella rufula (Spreng.) Sacc.
Valsaria citri Rehm.
Zignoella nobilis Rehm.
- Cocos nucifera* Linn. Coconut.
Anthostomella cocoina Syd.
Bacillus coli (Escherich).
 Bud rot, bacterial.
Capnodium footii Berk. et Desm.
Chaetosphaeria eximia Sacc.
Coniosporium dendriticum Sacc.
Coprinus fimbriatus B. et Br.
Ceprius friesii var. *obscurus* Pat.
Cytospora palmicola B. et C.
Diplodia cococarpa Sacc.
Diplodia cococarpa var. *malacensis* Tassi.
Diplodia epicocos Cooke.
Diplodia epicocos Cooke var. *minuscula* Sacc.
Elfvigia tornata (Pers.) Murr.
Eutypella cocos Ferd. et Winge.
Exosporium durum Sacc.
Ganoderma incrassatum (Berk.) Bres. var. *substipitata* Bres.
Gloeoglossum glutinosum (Per.) Durant.
Hormodendron cladosporioides (Fr.) Sacc.
Palawania cocos Syd.
Peroneutypella cocoes Syd.

- Cocos nucifera* Linn.—Continued.
Pestalozzia palmarum Cke. et Grev.
Phyllosticta cocophylla Pass.
Rosellinia cocoes Henn.
 Sterility of nuts.
Coffea spp. Coffee.
Aithaloderma longisetum Syd.
Coniothyrium coffeae Henn.
 Foot rot.
Hemileia vastatrix B. et Br.
Micropeltis mucosa Syd.
Rhizoctonia.
Sclerotium.
Colocasia esculentum Schott (*C. antiquorum* Schott). Gabi.
Phytophthora colocasiae Rac.
Cucumis sativas Linn. Cucumbers.
Cercospora.
Plasmopara cubensis (B. et C.) Humphrey.
Cucurbita maxima Duch. Calabaza, squash.
 Erysiphaceae.
Plasmopara cubensis (B. et C.) Humphrey.
Daucus carota Linn. Carrot.
Rhizoctonia.
Dioscorea esculenta (Lour.) Burkill.
 Yams.
Cercospora pachyderma Syd.
Cercospora ubi Rac.
Ellisiodothis rehmanniana Theiss et Syd.
Gloeosporium macrophomoides Sacc.
Lasioidiplodia theobromae (Pat.) Griff. et Maubl.
Nyctosphaerella dioscoreicola Syd.
Phoma oleracea Sacc.
Phomopsis dioscoreae Sacc.
Phyllachora dioscoreae Schwein.
Phyllachora rehmanniana Theiss. et Syd.
Phyllosticta graffiana Sacc.
Rhizopus.
Uredo dioscoreae (Berk. et Brm.) Petch.
Uredo dioscoreae-alatae Racib.
Dolichos lablab Linn. Lablab bean.
Cercospora.
Didymella lussoniensis Sacc.
Diplodia lablab Sacc.
- Dolichos lablab* Linn.—Continued.
Septoria lablabina Sacc.
Septoria lablabis Henn.
Vermicularia horridula Sacc.
Woroninella dolichi (Cke.) Syd.
Ficus carica Linn. Fig.
Kuehneola fici (Cast.) Butl.
Phyllachora. On wild figs.
Uredo fici Cast.
Glycine max (Linn.) Merr. (*G. hispida* Maxim.). Soy bean, soja.
Peronospora.
Rhizoctonia.
Trotteria venturioides Sacc.
Uromyces sojae Syd.
Gossypium spp. Cotton.
Bacterium malvacearum Erw. Smith.
Kuehneola desmium (B. et Br.) Syd.
Uredo desmium (B. et Br.) Petch.
Hevea brasiliensis (HBK) Muell.-Arg. Para rubber.
Eutypella heveae Yates.
Fomes lignosus (Kl.) Bres.
Helminthosporium heveae Petch.
Megalonectria pseudotrichia (Schw.) Speg.
 Physiological Trouble.
Phytophthora faberi Maubl.
 Spotting of prepared plantation rubber, saprophytic fungi.
Tryblidiella mindanaensis Henn.
Hibiscus sabdariffa Linn. Roselle.
Phoma sabdariffae Sacc.
Ipomoea batatas Poir. Sweet potato.
Lasioidiplodia theobromae (Pat.) Griff. et Maubl.
Rhizopus.
Lactuca sativa Linn. Lettuce.
 Tipburn, nonparasitic.
Lycopersicum esculentum Mill. Tomato.
Bacillus solanacearum Erw. Smith.
 Erysiphaceae.
Pythium debaryanum Hesse.
Rhizoctonia.
Mangifera indica Linn. Mango.
Cercospora mangiferae Koord.
Endoxyla mangiferae Henn.

- Mangifera indica* Linn.—Continued.
- Leptothyrium circumscissum* Syd.
Meliola mangiferae Earle.
Pestalozzia funerea Desm.
Pestalozzia pauciseta Sacc.
Phyllachora sp.
- Manihot dichotoma* Ule. Ceara rubber.
Phyllosticta manihotica Syd.
Manihot utilissima Pohl. Cassava, camoting cahoy.
Cercospora henningsii Allesch.
Cercospora manihotis Henn.
Colletotrichum lussoniense Sacc.
Diplodia manihoti Sacc.
Guignardia manihoti Sacc.
Guignardia manihoti Sacc. var. *diminuta* Sacc.
Phoma herbarum Westd.
Steirochaete lussoniensis Sacc.
- Morus alba* Linn. Mulberry.
Botryodiplodia anceps Sacc. et Syd.
Diplodia mori West.
Kuehneola fici (Cast.) Butl. var. *moricola* Henn.
Phyllactinia suffulta (Reb.) Sacc.
Traversoa dothiorelloides Sacc. et Syd.
 Twig fungi.
Valsaria insitiva (de Not.) Ces. et de Not.
- Mucuna deeringiana* Merr. (*Stizolobium deeringiana* Bort). Velvet bean.
Cercospora stizolobii Syd.
Uromyces mucunae Rabh.
- Musa sapientum* Linn. Banana.
 Bacterial stem rot.
Diplodia crebra Sacc.
 Fruit blast.
Macrophoma musae (Cke.) Berl. et Vogl.
Mycosphaerella musae Speg.
Plicaria bananincola Rehm.
Sporodesmium bakeri Syd.
- Musa textilis* Néé. Abacá.
 Bacterial heart rot.
Macrophoma musae (Cke.) Berl. et Vogl.
Mycosphaerella musae Speg.
- Nicotiana tabacum* Linn. Tobacco.
- Nicotiana tabacum* Linn.—Cont.
Bacillus solanacearum Erw. Smith.
 Bacterial blight.
Cercospora nicotianae Ell. et Ev.
 Chlorosis.
 Curing and fermenting troubles. Leaf spotting.
Fusarium.
Heterodera radiculicola Greef et Müller. (Nematodes.)
Phytophthora nicotianae Breda de Haan.
Pythium debaryanum Hesse.
Rhizoctonia.
Sclerotium.
- Oryza sativa* Linn. Rice.
 Bacterial leaf stripe.
Calonectria perpussilla Sacc.
Cercospora.
Clasterosporium punctiforme Sacc.
Coniosporium oryzinum Sacc.
Entyloma oryzae Syd.
Haplographium chlorocephalum (Fres.) Grove.
Helminthosporium.
Leptosphaeria (Leptosphaerella) oryzina Sacc.
Myrothecium oryzae Sacc.
Oospora oryzetorum Sacc.
Ophiobolus oryzinus Sacc.
Phyllosticta glumarum Sacc.
Phyllosticta miurai Miyake.
Rhizoctonia.
Sclerotium.
Septoria miyakei Sacc.
Sordaria oryzeti Sacc.
Spegazzinia ornata Sacc.
 Straight or sterile head.
Ustilagoideia virens (Cke.) Tak.
- Pachyrrhizus erosus* (Linn.) Urb. (*P. angulatus* Rich.). Sincamas.
Phakospora pachyrrhizi Syd.
- Phaseolus* spp. Beans.
Cercospora lussoniensis Sacc.
 Erysiphaceae.
Phyllachora phaseolina Syd.
Pseudomonas phaseoli Erw. Smith.
Rhizoctonia.
Sclerotium.

Phaseolus spp.—Continued.
 Sooty mold.
Uromyces appendiculatus (Pers.) Lk.
Phaseolus lunatus Linn.
Cladosporium herbarum (Pers.) Lk.
Diplodia phaseolina Sacc.
Phaseolus vulgaris Linn.
Asteroma phaseoli Brun.
Diplodia phaseolina Sacc.
 Piper betle Linn. Icmo, betel pepper.
Oospora perpusilla Sacc.
Pisum sativum Linn. Pea.
 Erysiphaceae.
Psophocarpus tetragonolobus DC.
 Winged bean, calamismis.
Woroninella psophocarpi Rac.
Raphanus sativus Linn. Radish.
Bacillus carotovorus Jones.
Saccharum officinarum Linn. Sugar cane.
Aeginetia indica Linn. (Broom rape.)
Apiospora camptospora Penz. et Sacc.
Bakerophoma sacchari Diedicke.
Cercospora.
Coniosporium extremorum Syd.
Coniosporium vinosum (B. et C.) Sacc.
Dictyophora phalloidea Desvaux.
Haplosporella melanconioides Sacc. forma.
Heterodera radicola Greef et Müller. (Nematodes.)
Marasmius.
Melanconium lineolatum Sacc.
Melanconium sacchari Massee.
Meliola arundinis Pat.
Phyllachora sacchari Henn.
Puccinia kuehnii (Krueg.) Butl. [*Uredo kuehnii* (Krueg.) Wakk. et Went].
Rhizoctonia.
 Sereh disease.
 Stem rot, bacterial.
Ustilago sacchari Rabh.
Saccharum spontaneum Linn. Wild sugar cane.
Haplosporella melanconioides Sacc.

Saccharum spontaneum Linn.—Cont.
Phyllachora sacchari spontanei Syd.
Ustilago sacchari Rabh.
Sesamum indicum Linn. Sesame, linga.
Cercospora sesami A. Zimm.
 Erysiphaceae.
Gloeosporium macrophomoides Sacc.
Helminthosporium sesameum Sacc.
Phoma sesamina Sacc.
Vermicularia sesamina Sacc.
Solanum melongena Linn. Eggplant.
Bacillus solanacearum Erw. Smith.
Diplodina degenerans Diedicke.
Gloeosporium melongenae Sacc.
Phoma solanophila Oud.
Sarcinella raimundoi Sacc.
Solanum tuberosum Linn. Potato.
Bacillus phytophthorus Appel.
Bacillus solanacearum Erw. Smith.
Phytophthora infestans (Mont.) de Bary.
Theobroma cacao Linn. Cacao.
Aspergillus delacroixii Sacc. et Syd.
Botryosphaeria minuscula Sacc.
 Canker.
Cyphella holstii Henn.
 Die-back.
Fusarium theobromae App. et Strunk.
Lasiodiplodia theobromae (Pat.) Griff. et Maubl.
 Lichens.
Mycogone cervina Ditm. var. *theobromae* Sacc.
Nectria bainii Massee var. *hypoleuca* Sacc.
Nectria discophora Mont.
Oospora candidula Sacc.
Ophionectria theobromae (Pat.) Duss.
Physalospora affinis Sacc.
Phytophthora faberi Maubl.
Vigna spp. Cowpeas.
Cercospora.
 Erysiphaceae.

<i>Vigna</i> spp.—Continued.	Control of plant diseases.
<i>Fusarium</i> .	General discussion.
<i>Phoma bakeriana</i> Sacc.	Plant sanitation.
<i>Rhizoctonia</i> .	Crop rotation.
<i>Uredo vignae</i> Bres.	Cultural methods.
<i>Xanthosoma sagittifolium</i> Schott.	Disease-resistant varieties.
Yautia.	Soil sterilization.
<i>Vermicularia xanthosomatis</i>	Direct-heating method.
Sacc.	Formalin disinfection.
<i>Zea mays</i> Linn. Corn, maize.	Fungicides.
<i>Acerbia maydis</i> Rehm.	Standard Bordeaux mixture.
<i>Broomella zeae</i> Rehm.	Burgundy mixture.
<i>Clasterosporium maydicum</i> Sacc.	Soda Bordeaux mixture.
Dry rot, sterile fungus.	Ammoniacal solution of copper carbonate.
<i>Fusarium</i> .	Resin-salsoda sticker.
<i>Helminthosporium curvulum</i>	Sulphur.
Sacc.	Lime-sulphur spray.
<i>Helminthosporium inconspicuum</i>	Self-boiled lime-sulphur spray.
C. et E.	Formalin spray.
<i>Leptosphaeria orthogramma</i> (B. et Br.) Sacc.	Formalin.
<i>Physalospora linearis</i> Sacc.	Corrosive sublimate.
<i>Sclerospora maydis</i> (Rac.) Butl.	Spraying apparatus.
<i>Ustilago zeae</i> (Beckm.) Ung.	

INTRODUCTION

Fungous diseases are found on practically all cultivated and wild plants in Laguna Province, Philippine Islands. From this local abundance it is to be presumed with a great degree of assurance that they are equally prevalent in most, if not all, the other agricultural regions of the Islands. They are often the limiting factors in the raising of many agricultural crops. Climatic conditions of the Philippines account for the great number and destructiveness of plant diseases, for the growth and development of fungi are enhanced by warmth and moisture. During the rainy season both of these factors are present, thereby aiding the large destruction during this period of the year. Plant diseases are seasonal; that is, they are more numerous and severe during the wetter months of the year, extending from July to November. A person going through the Islands during the dry season will not be impressed with the number and destructiveness of plant diseases, but during the rainy season the reverse will be found true. No complete estimates of losses due to plant diseases have been prepared in the Philippines, but it would be safe to say that in this section of the country at least 10 per cent of agricultural crops are destroyed by fungi.

Certain articles on phytopathology in the tropics give an en-

tirely wrong impression of the number and destructiveness of the diseases.¹ In the Malayan regions, at least so far as the Philippines are concerned, there are represented all the groups of fungi that are present in temperate regions. Extremely destructive diseases are produced by some members of each group. Forest pathology has never been really investigated, but there are many important and destructive timber fungi. The powdery mildews, Erysiphaceae, may be very abundant and often destructive during the cooler, drier months of the year. The perfect stage has been only observed with a powdery mildew growing on the leaves of a forest tree, *Premna cumingiana* Schau. This ascigerous stage is of the genus *Uncinula*. Leaf-spotting fungi are very common and some are extremely destructive. Destructive rusts are present on coffee, sugar cane, and sorghum. Bacterial diseases are present in abundance, many being highly destructive. Certain diseases caused by Phycomycetes and imperfect fungi may be very severe. There are as many destructive plant diseases in the Philippine Islands as there are in the United States, if there are not more.

The seriousness of some of the diseases can be judged by the fact that the coffee industry of the Islands was wiped out by a fungus, that the coconut industry suffers severely in certain sections from destruction of trees in all stages of growth due to bud rot, that the abacá industry sustains great losses due to bacterial attack, that one-half of the cacao fruit is destroyed by fungi, and that rice culture is seriously hampered by fungus attacks. This is also true of the sugar and citrus industries and the culture of all vegetables.

The great factors in the spread and destructiveness of fungi are the lack of proper culture, of sanitation, of pruning, and of spraying. The Filipino farmer plants his crops and allows Providence to do the rest. Ignorance concerning plant diseases and disease control, together with lack of foresight of the people, along general cultural lines, accounts for a good deal of loss. In some few instances growers know that the plants are diseased and that they ought to be removed, but still they do nothing. They figure that as long as they are getting fair returns from their crops they need not worry about the future. There is great need of education among the mass of Filipino farmers with regard to the spread of plant diseases and their prevention as well as for providing properly educated inspectors to safe-

¹ Westerdijk, *Phytopathology in the tropics*, *Ann. Missouri Bot. Gardens* (1915), 2, 307-313.

guard the interests of the thrifty and foresighted farmer who does know how to spray and who puts his knowledge into practice. As it is, practically no spraying is carried on in the Islands.

This paper has been written in order to give some idea of the prevalence of plant diseases, their causes, mode of attack, plant hosts, amount of damage, and methods of control. While the list of diseases is by no means complete and while it takes into consideration primarily those diseases found in Laguna and near-by provinces in Luzon, it will demonstrate that practically all agricultural crops have their fungus enemies. Many of these diseases are due to fungus species new to science. The contribution of these new species has been largely due to the collections of Prof. C. F. Baker, professor of agronomy in the College of Agriculture.

ANANAS COMOSUS (LINN.) MERR. (A. SATIVUS SCHULTES F.).
PINEAPPLE

LEAF SPOT: ASTERINELLA STUHLMANNI (HENN.) THEISSEN

Symptoms.—The lower leaves of the pineapple are frequently and sometimes seriously attacked by this superficial leaf-spotting fungus. The black mass of mycelium produces spots that extend rapidly and often cover the entire leaf. Older spots are frequently elevated, due to the shrinkage of the surrounding tissue, and they have dark gray centers covered with minute black specks, the perithecia. The fungus causes the premature death of the lower older leaves.

Causal organism.—The perithecia are usually seen with the naked eye. They appear as minute black specks in the grayish diseased portion. The asci within the perithecia are sack-shaped bodies and usually contain eight ascospores. The latter are two-celled and elongated, with a large vacuole in each cell. The fungus is a superficial grower, but feeds on the cells by the production of haustoria, and in this way it weakens the leaves.

Control.—Sanitation methods are advisable, such as the collection and destruction of the older, badly diseased leaves. In severe cases of infection crop rotation should be practiced.

Lembosia bromeliacearum Rehm. is also found growing superficially on the living leaves, parasitizing them by the production of haustoria.

SOOTY MOLD

Symptoms.—Black felty masses of a superficially growing fungus may be produced on the under surfaces of leaves. The

fungus has not been prevalent enough to cause any serious damage (Plate XIV, fig. 1). It has not been identified.

Steirochaete ananassae Sacc. and *Diplodia ananassae* Sacc. are found on dead leaves.

ANDROPOGON SORGHUM LINN. (SORGHUM VULGARE PERS.).
SORGHUMS, KAFFIRS, MILOS

GRAIN MOLD: HELMINTHOSPORIUM CARYOPSIDUM SACCARDO

Symptoms.—Grains are frequently covered with a dense black or sometimes dark greenish mold. Generally little damage is done, but in severe cases of infection seeds may be destroyed.

Causal organism.—The mold is made up of mycelium, conidiophores, and the many-celled, curved brownish conidia.

Control.—The seeds should be carefully dried and stored in a well-ventilated dry place.

KERNEL SMUT: USTILAGO SORGHI (LK.) PASSARINI

Symptoms.—This disease though not serious is, however, occasionally present. Individual grains of the panicle are affected. Diseased heads appear normal except for the infected grains. Smutted grains are much enlarged and have a black smutty mass of spores protruding between the glumes (Plate I, fig. 3).

Causal organism.—The smutty mass is composed of round, smooth, brownish smut spores. These spores germinate by the production of a promycelium, from which are produced hyaline sporidia.

Control.—Only seeds free from smut should be planted. All diseased heads should be collected and burned. Crop rotation will check the disease.

LEAF SPOT: PHYLLACHORA SORGHI V. HÖHNEL

Symptoms.—Leaves are badly attacked by this fungus, which produces thickly scattered black spots over the surface. Spots are small, 1 to 4 millimeters in diameter, roundish, sometimes elongated, raised, extending through the leaf on both surfaces, and are made up of hard stromatic masses of the fungus (Plate I, fig. 1). These black stromatic masses may be surrounded by a dark reddish or yellowish ring, produced by the discoloration of leaf tissue. The reddish spots frequently run together, producing a much-reddened leaf. The disease is often serious enough to destroy leaves for use as fodder, as well as to lower the vitality of plants.

Causal organism.—Within the stromata are produced usually one or two perithecia, which contain numerous asci, ascospores,

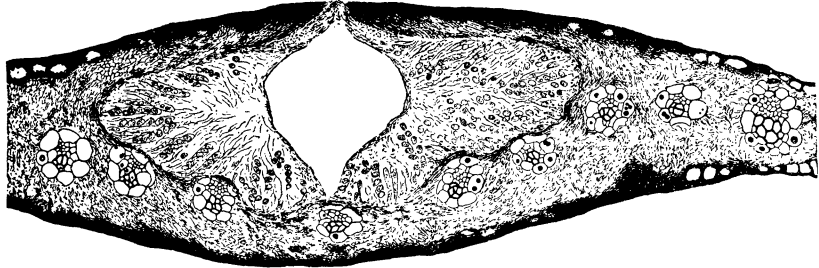

FIG. 1. *Phyllachora sorghi* v. Höhnel. Cross section of stroma, showing perithecium, ostium, asci, and ascospores ($\times 75$). Vascular bundles of leaf develop normally within the mass of fungus mycelium.

and paraphyses. Sections through the stromata disclose the interesting fact that the vascular bundles of the leaf are not at all injured, for these bundles develop apparently normally within the mass of fungus mycelium (fig. 1). The passage of food and water is not inhibited by the fungus, but the vitality of the plant is lowered, for the fungus absorbs food for the development of its own body and also reduces the chlorophyll area of the leaf. Asci are typical, club-shaped bodies containing usually eight hyaline spores. The ascospores are elongated and granular, with the contents often collected in each end, which in some cases makes them appear two-celled (fig. 2). The paraphyses are slender, hyaline bodies and are produced in abundance.

Control.—No special control need be practiced. Crop rotation and sanitation will check the disease.

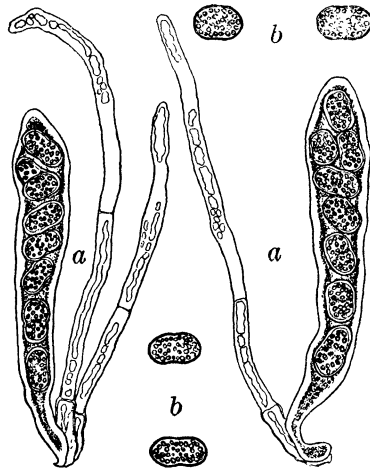

FIG. 2. *Phyllachora sorghi* v. Höhnel. a, asci with paraphyses ($\times 325$); b, ascospores ($\times 325$).

RUST: PUCCINIA PURPUREA COOKE

Symptoms.—Leaves may be entirely covered with rust sori, which lower the vitality of the plants and render them worthless for forage. Sori are brownish, at first closed, later ruptured, exposing the spores; are raised, elongated, about 1 millimeter by 2 millimeters, and are frequently surrounded by a dark reddish to purplish discoloration of the leaf surface. Badly infected leaves are usually entirely spotted and are nearly covered with a reddish to purplish discoloration (Plate I, fig. 2).

Causal organism.—Within the sori are produced in abundance one-celled, yellow to brown, usually ovate, spiny uredospores. They may in some cases retain a stalk. Prominent pores are developed. Teleutospores are not produced in such abundance. They may be developed along with uredospores, but usually predominate in sori within which they are found. The teleutospores are two-celled, thick-walled, dark brown, and smooth and usually have a stalk (fig. 3).

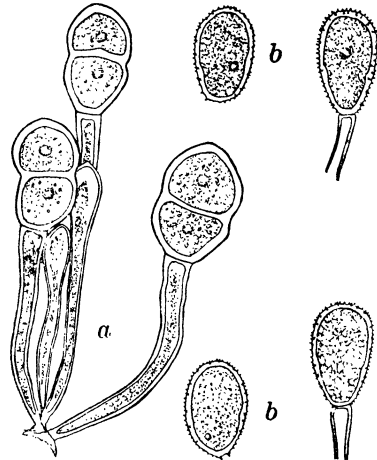

FIG. 3. *Puccinia purpurea* Cooke. a, teleutospores ($\times 315$); b, uredospores ($\times 315$).

Control.—Crop rotation and the destruction of badly diseased plants should be practiced.

SOOTY MOLD

Symptoms.—Frequently a dense sooty mold may be produced on leaves attacked by aphids. The fungus grows superficially, living on the exudate of the aphids. Little injury is done. The fungus has not been identified.

Didymosphaeria anisomera Sacc. has been identified from languished and dead leaves. On dying leaves, *Fumago vagans* Pers. may be found. *Coniosporium sorghi* Sacc. is found in dead and decaying stalks.

ANNONA MURICATA LINN. SOURSOP, GUANABANO

LEAF SPOT: PHYLLOSTICTA INSULARUM SACCARDO

Symptoms.—A common and sometimes destructive leaf disease. Spots are irregular and gray to whitish and start at the margins.

APIUM GRAVEOLENS LINN. CELERY

EARLY BLIGHT: CERCOSPORA APII FRIES

Symptoms.—Irregular roundish spots, which often run together forming blotches, may cover the leaf surface. When young the spots are light brownish, bordered with a yellowing of the leaf. Older spots have ashen gray centers surrounded with

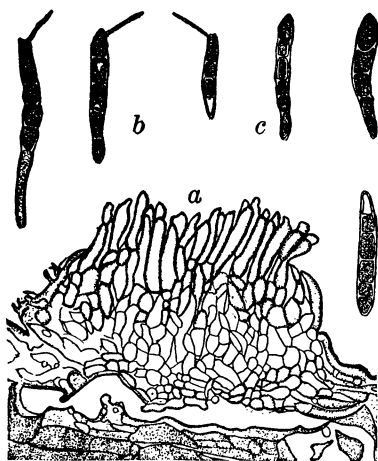

FIG. 4. *Septogloeum arachidis* Rac. a, cushionlike structure of conidiophores ($\times 350$); b, germinating conidia ($\times 350$); c, conidia ($\times 350$).

brown. On the surface in the grayish portion is produced a black powdery mass.

Causal organism.—This black powdery mass is made up of hyaline, many-celled tapering conidia, which are produced on brownish conidiophores. The conidiophores are formed in groups and are septate.

Control.—Diseased plants should not be allowed to accumulate in the soil. Crop rotation should be practiced. In severe cases of infection, spraying Bordeaux mixture will have to be resorted to.

ARACHIS HYPOGAEA LINN. PEANUT, MANI

LEAF SPOT: SEPTOGLOEUM ARACHIDIS RACIBORSKI

Symptoms.—This well-known and widely distributed leaf spot may be extremely destructive on certain varieties of peanuts. It affects the lower leaves of the plant, and complete defoliation of this portion may result. From the lower portions the disease spreads to the upper leaves. The disease is most severe during damp weather, when both leaves and stems are attacked. Spots on the leaves are usually circular, black to brown, with a yellowish discoloration of the leaf tissue adjacent to the spot. The centers of older spots, chiefly on the under leaf surface, are specked with the raised masses of conidia and conidiophores. Spots on the stem are similar, but are usually elongated lengthwise. Certain varieties of peanuts show a marked degree of resistance.

Causal organism.—The more or less powdery, elevated bodies on the under surface of the spot are cushionlike structures made up of a mass of conidiophores and conidia (fig. 4). The elongated spores are brown and usually consist of from three to four cells. They germinate readily in water by the production of germ tubes, most frequently from one of the end cells (fig. 4). Inoculation experiments are easily carried out by spraying plants with a spore suspension. Penetration into the tissue is by means of the stomata (fig. 5). After gaining entrance, the mycelium spreads in local spots throughout the leaf, causing the death of the cells and the consequent browning of the tissue. The fungus

threads accumulate usually at the lower surface of the spots, producing the cushions of conidiophores and conidia. In pure culture it grows very slowly. On potato agar a raised, more or less leathery, dark brown mass of mycelium is produced. As yet no spores have been observed growing in pure culture.

Control.—The disease may be held in check by the growth of resistant and acclimatized varieties. The leaf spotting is most severe on the lower leaves, indicating infection from spores in the soil. Crop rotation will eliminate this last source of infection to a marked degree.

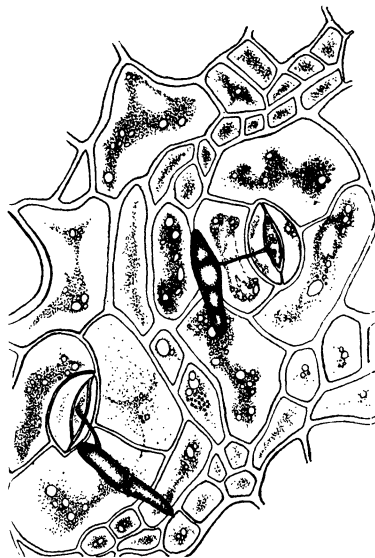

FIG. 5. *Septogloeum arachidis* Rac. Germinating conidia ($\times 350$); germ tubes entering host tissue by way of stomata.

ROOT ROT: SCLEROTIUM

Symptoms.—Frequently peanuts are attacked by a fungus causing a rot of the root and the lower stems. Sclerotial bodies are always associated with the disease. As a rule the disease does not cause serious damage.

Causal organism.—The organism is a common soil fungus attacking a large number of plants. It is similar to that discussed under coffee.

Control.—Crop rotation should be practiced.

ARECA CATECHU LINN. BUNGA, BETEL PALM

The betel palm is attacked by a large number of fungi. *Pestalozzia palmarum* Cooke, *Exosporium pulchellum* Sacc., and *Exosporium hypoxylodes* Syd. cause leaf spots similar to those discussed under coconut. On dead leaves may be found *Guignardia arecae* Sacc., *Diplodia arecina* Sacc., and *Phomopsis palmicola* (Wint.) Sacc. On dead leaf sheafs may be found *Colletotrichum arecae* Syd., *Gloeosporium palmarum* Oud., and *Zygosporium oscheoides* Mont. On dead petioles may be found *Phomopsis arecae* Syd. and *Anthostomella arecae* Rehm. On dead fruit may be found *Gloeosporium catechu* Syd. On dead trunks may

be found *Peroneutypella arecae* Syd., *Eutypella rehmiana* (Henn. et Nym.) v. Höhnel, *Elfvigia tornata* (Pers.) Murr., and *Phellostroma hypoxylodes* Syd.

ARTOCARPUS COMMUNIS FORST. (ARTOCARPUS INCISA LINN. F.).
BREADFRUIT

FRUIT ROT: RHIZOPUS ARTOCARPI RACIBORSKI

Symptoms.—The same fruit rot occurs on *Artocarpus communis* Forst. as is discussed under *Artocarpus integra* (Raderm.) Merr.

LEAF SPOT: CERCOSPORA ARTOCARPI SYDOW

Symptoms.—The common breadfruit tree is attacked by this typical *Cercospora* spot-producing fungus. Spots are more or less irregular with gray centers. Little damage is done.

Marchalia constellata (B. et Br.) Sacc. also causes a leaf spot. *Diplodia artocarp* Sacc. may be found on languishing leaves. *Cycloderma depressum* Pat. may be found on the trunk.

ARTOCARPUS INTEGRAL (RADERM.) MERR. (ARTOCARPUS INTEGRIFOLIA LINN. F.). JACK FRUIT, NANGCA

FRUIT ROT: RHIZOPUS ARTOCARPI RACIBORSKI

Symptoms.—The male inflorescence and young fruit may be attacked by this fungus. The blossoms are killed. Young inflorescences, 5 to 10 centimeters long, are subject to attack.

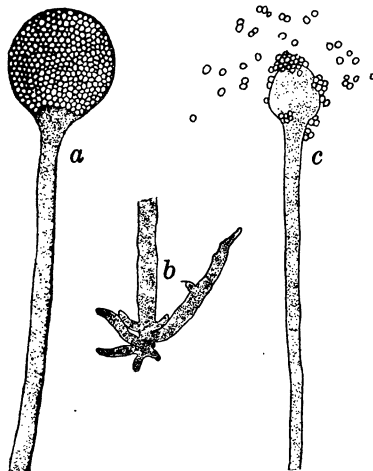

FIG. 6. *Rhizopus artocarp* Rac. a, sporangium with spores (X 330); b, rhizoid (X 330), from tissue of fruit; c, bursted sporangium showing columella, sporangiophore, and spores (X 330).

On these the organism usually starts at the stem end or in wounds, causing a soft rot. The entire rotted portion is eventually covered with a dense black growth of the fungus, with the characteristic mold sporangia protruding. The fungus gradually advances, until the entire inflorescence becomes rotted and drops (Plate XIX, fig. 6). Extensive damage may be produced.

Causal organism.—Typical *Rhizopus* sporangia and sporangiophores are produced. The outer walls of the sporangia are very delicate, breaking upon contact with water and spreading the spores (fig. 6). The fungus grows well in pure culture,

producing on potato agar a dense mass of sporangiophores with their blackish sporangia. Inoculation experiments prove this fungus to be highly parasitic. Young inflorescences on the tree are completely covered with the black mass of spore-bearing bodies three days after inoculation. The mycelium invades the tissue with rhizoids and produces a soft rot. The disease spreads rapidly during damp weather.

Control.—All diseased inflorescences should be carefully picked from the tree and the ground and destroyed. Care should be taken not to scatter the spores. In severe cases spraying with Bordeaux mixture may be practiced.

Dying leaves of the jack fruit may be attacked by *Diplodia artocarpina* Sacc. and *Dichotomella areolata* Sacc.

BETA VULGARIS LINN. CHARD

LEAF SPOT: CERCOSPORA

Symptoms.—The common leaf spot of the chard is often very destructive. Leaves of Swiss chard may be entirely covered with the characteristic spots. Spots when young are small and brownish to black; as they get older, they become larger, sometimes increasing up to 5 millimeters in diameter. Older spots are circular and brownish and may exhibit concentric rings, and the very oldest spots have an ashen-gray center bordered with a brownish ring. Spots may coalesce and cover nearly the entire leaf surface (Plate II, fig. 3).

Causal organism.—Conidiophores and conidia are produced in abundance in the ashen-gray center of the spots. Conidia are long, tapering, and hyaline; conidiophores are yellowish and in groups. The fungus grows readily in pure culture, producing on potato agar a more or less feltlike mass of white fungus, with a slight pinkish tinge.

Control.—The most satisfactory control consists in the collection and the destruction of diseased leaves and in crop rotation.

BRASSICA OLERACEA LINN. CABBAGE

BLACK ROT: PSEUDOMONAS CAMPESTRIS (PAMMEL.) ERW. SMITH

Symptoms.—The disease is characterized by the yellowing of the leaves at the margins and between the veins and the blackening of the veins. Cross sections of diseased petioles show blackened fibrovascular bundles (Plate X, fig. 2).

Causal organism.—Pure cultures of the bacteria indicate that the organism is the same as that attacking cabbage in the United States, whence it was undoubtedly introduced on seed.

The bacteria gain entrance into the plant through water pores at the margin of the leaf and through injuries on the leaf surface. After gaining entrance, the organism multiplies rapidly and spreads primarily through the fibrovascular bundles, causing them to blacken. The bacteria frequently ooze in a yellow mass from the cut bundles. From the leaves the organism spreads through the vascular bundles into the stem, causing a rot and consequent death of the plant (Plate X, fig. 2).

Control.—The collection and destruction of infected leaves may be effective as a control, if these leaves be picked before the organism has spread into the stem of the plant. When once the soil has become infected, crop rotation is the only method of control. Care should be taken that only healthy, noninfected seedlings are set out from the seed bed. The disease is spread on seeds. Seed treatment with either mercuric bichloride, 1 to 1,000, for fifteen minutes or 1 to 2 per cent formalin for twenty minutes is effective.

BRASSICA PEKINENSIS (LOUR.) SKEELS. PECHAY

LEAF SPOT: *CERCOSPORA BRASSICICOLA* P. HENNINGS

Symptoms.—Frequently severe spotting of the lower leaves occurs, making them unfit for food. Characteristic *Cercospora* spots, with ashen-gray centers bordered with light brown, are produced. These spots range from 1 to 15 millimeters in diameter. The older, larger spots frequently have concentric rings of gray and dark brown. The ashen-gray center of older spots

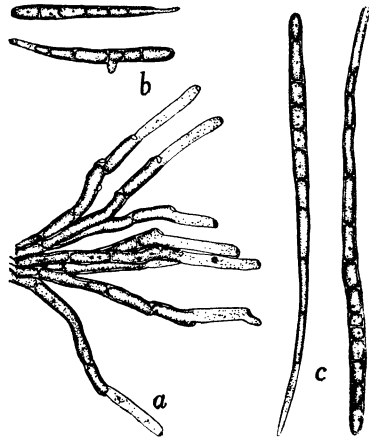

FIG. 7. *Cercospora brassicicola* Henn. a, group of conidiophores ($\times 340$); b, small conidia germinating ($\times 340$); c, typical needlelike conidia ($\times 340$).

is covered with a black mass of conidiophores and conidia (Plate II, figs. 1 and 2).

Causal organism.—The conidiophores are produced in groups arising from the stomata. They are septate and light brown. The conidia are hyaline, tapering, and from five- to fifteen-celled (fig. 7). Conidiophores as well as conidia may germinate and cause infection.

Control.—All diseased leaves should be collected and burned. Crop rotation should be practiced.

Cercospora armoraciae Sacc. also has been found on *Brassica*

pekinensis (Lour.) Skeels, where it produces a leaf spot similar to the one described above.

CANAVALIA GLADIATA DC., CANAVALIA ENSIFORMIS DC. HORSE BEANS, SWORD BEANS

These two beans may be attacked by *Elsinoe canavaliae* Rac., *Gloeosporium canavaliae* Syd., *Physalospora guignardioides* Sacc., and *Cercospora canavaliae* Syd. On decaying leaves of *Canavalia gladiata* DC. may be found *Didymium squamulosum* (Alb. et Schw.) Fr.

CAPSICUM ANNUUM LINN. RED PEPPER

BACTERIAL WILT: BACILLUS SOLANACEARUM ERW. SMITH

The bacterial wilt, which is so destructive on other solanaceous plants, attacks the peppers also. This disease is similar to that on tomato and tobacco, under which it is more fully described.

FRUIT ROT: VERMICULARIA CAPSICI SYDOW

Symptoms.—A spotting of the fruit characterized by the production of soft, often circular, sunken spots. The center of spots may dry, forming concentric rings within which small black spore-bearing bodies are produced. The disease is common, causing rotting of the fruit (Plate XVIII, fig. 2).

Causal organism.—The minute black specks produced in the depressed areas are the pycnidia of the fungus. They have numerous slender pointed setæ and produce elongated, hyaline conidia.

Control.—The collection and destruction of diseased pods should be practiced to check the disease. Spraying with Bordeaux mixture is effective when practicable.

On dried pods may be found the fungus *Phomopsis capsici* (Magnaghi) Sacc.

POWDERY MILDEW: ERYSIPTACEAE

Symptoms.—A white powdery growth may be produced on the surface of the leaves. At times the disease may be severe.

Causal organism.—The conidia are somewhat more elongated than the typical erysiptaceous spores, but they are produced in chains on the typical conidiophores.

Control.—Badly diseased plants should be dusted with sulphur or sprayed with a standard fungicide. Crop rotation should be practiced.

CAPSICUM FRUTESCENS LINN. RED PEPPER

FRUIT ROT: VERMICULARIA CAPSICI SYDOW

Symptoms.—A fruit rot similar to that found on *Capsicum annuum* Linn.

CARICA PAPAYA LINN. PAPAYA

DAMPING OFF: RHIZOCTONIA AND PYTHIUM DEBARYANUM HESSE

Symptoms.—Frequently young seedlings are attacked by soil fungi just at the surface of the ground. The stem first becomes watery, then turns brownish, and shrivels up, resulting in the falling over of the plant.

Causal organism.—Either of two common soil fungi, *Rhizoctonia* and *Pythium debaryanum* Hesse, may produce the disease. The *Rhizoctonia* grows well in pure culture, producing a brownish mycelium and brown sclerotial bodies. *Pythium* may be recognized in the plant tissue by its characteristic fruiting bodies.

Control.—All soil used for the growth of seedlings should be sterilized. Seed flats should be placed in a well-aërated place and sunned from time to time.

FRUIT ROT: FUSARIUM

Symptoms.—Frequently a *Fusarium* causes the rotting of mature fruit. The rot is similar in appearance to that caused by *Phytophthora*, except that the surface of this rot is covered with the dense growth of *Fusarium*. Spores are produced in abundance. Often rots are accompanied by various mold fungi, among them being a *Rhizopus* and a *Penicillium*.

FRUIT ROT: LASIODIPLODIA THEOBROMAE (PAT.) GRIFFON ET MAUBLANC

Symptoms.—A somewhat dry rot of papaya fruit is due to the attacks of this fungus. The diseased fruits are characterized by the production of a sooty black mass of fungus spores on the surface.

Causal organism.—This fungus is the same as that producing a dry rot of cacao pods, root crops, and other vegetables.

Control.—All fruit rots may be controlled by taking care that no injuries are produced on the fruit during harvesting and that the fruit is used before becoming soft.

FRUIT ROT: PHYTOPHTHORA FABERI MAUBLANC

Symptoms.—This fungus may cause a soft rot of the mature fruit. The rot starts usually at some injury and spreads until the entire fruit becomes involved. Diseased fruits are covered by a white fungous growth.

Causal organism.—The organism producing this disease is the same as that producing the black rot of cacao pods. Conidia and oöspores are developed in abundance by the fungus. The fungus grows well in pure culture, being easily obtained by

simple plating out methods. It is more fully discussed under black rot of cacao pods.

Control.—The fruit should be handled so as to avoid injuries, and it should be used before it gets overripe.

LEAF ROT: MYCOSPHAERELLA CARICAE SYDOW

Symptoms.—This is a common leaf spot which, at times, may severely attack plants, causing a lack of vigor and a premature dropping of the older leaves. Circular spots, from a few millimeters to a centimeter in diameter, are produced. Older spots have an ashen-gray center surrounded by concentric light-brown rings bordered with darker brown. In the center of the older spots the minute black perithecia are produced.

Causal organism.—The perithecia are produced under the epidermal layer. They are more or less globular and brown with a distinct netted wall marking. An ostiolum is present at one end of the sack, protruding through the epidermal layer of the leaf (fig. 8). The asci, borne within, are elongated, club-shaped bodies containing typically eight two-celled, hyaline, vacuolated spores (fig. 8).

Control.—Since this disease is of minor importance, no specific control measure need be practiced. The collection and burning of all fallen or badly diseased leaves is beneficial in checking the fungus.

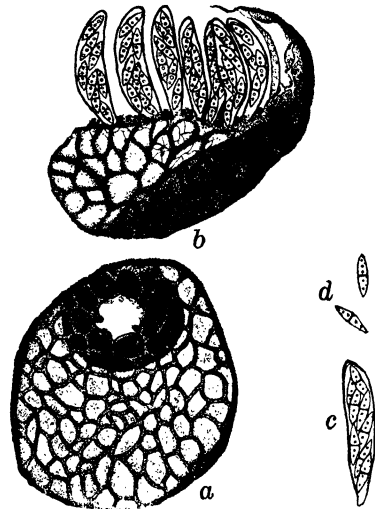

FIG. 8. *Mycosphaerella caricae* Syd. a, perithecium ($\times 325$); b, broken perithecium showing production of asci ($\times 325$); c, ascus with ascospores ($\times 325$); d, ascospores ($\times 325$).

POWDERY MILDEW: ERYSIPTHACEAE

Symptoms.—Under favorable weather conditions papaya seedlings may be covered with a white powdery mildew. The disease is not severe.

Causal organism.—Typical erysiptaceous conidia and conidiophores are produced. No perfect stage of the fungus has been observed.

Control.—The disease is seldom severe enough to warrant a special control. Powdering plants with sulphur will check the disease.

Other fungi have been found on weakened and dead portions of the plant. *Aspergillus periconioides* Sacc. is commonly found on weakened and fallen leaves. *Colletotrichum papayae* (Henn.) Syd., *Diplodia caricae* Sacc., and *Didymella caricae* Tassi. have been found on dead and dying petioles. *Fusarium heveae* Henn. may be found on dead trunks.

CITRUS SPP. ORANGES, LEMONS, LIMES, POMELOS

Citrus culture is carried on in certain sections of the Islands. As is also true with the majority of the other fruit crops, little care is given citrus trees in the way of cleaning up, pruning, spraying, and cultivating. Consequently the trees are sickly, and in many cases they are severely attacked by insects and fungi.

BARK ROT

Symptoms.—Citrus trees growing in neglected and poorly kept orchards may be seriously attacked with a bark rot. The first indication of the rot is a slightly raised, sometimes cracked portion, from which usually a drop of gum oozes. These portions gradually increase in size; gum, in most cases, oozes out in more abundance; and in the latter stages a froth is present, indicating the presence of yeasts and other saprophytic organisms. These older cracked and rotted portions may be 0.5 to 5 centimeters wide and from 3 to 10 or 15 centimeters long, extending lengthwise with the trunk. In the older cases the bark gradually sloughs off, producing an irregular rotted portion in the bark down to the wood.

An internal symptom of new rots is a slight brownish watery discoloration. Usually there is a green coloration produced just below the rotted portion. This green coloration appears to be due to the abnormal production of chlorophyll. Older rotted portions may also show this greenish coloration, but the diseased parts are more or less brownish and usually covered with a watery frothy substance. A disagreeable odor is present in the older cases of disease.

Causal organism.—No work has been done with the causal organism. The disease appears to be produced by a definite organism.

Control.—Since the cause is not known no definite control can be assigned. Trees that are neglected and given poor culture seem to be more severely attacked. All badly diseased branches should be removed and burned. This with proper culture measures will reduce the disease to a considerable extent.

CANKER: PSEUDOMONAS CITRI HASSE

This infectious and destructive disease is widely prevalent in the Islands. On the commonly planted citrus fruit, *Citrus nobilis* Lour. (Satsuma orange, Canton mandarin), the disease is only slightly prevalent and does little damage. It is, however, severe on certain species in the college plantation at Los Baños, Laguna, where test varieties are grown. These different varieties are affected in the following order, the first-named being the most severely attacked: *Citrus maxima* (Burm.) Merr. (*Citrus decumana* Linn.) (large pomelo, bitter pomelo, djersek boli), *Citrus* sp. (Kusaie lime), *Citrus* (large orange), *Citrus* (Lisbon lemon), *Citrus* (Washington navel), *Citrus* (rough lemon), *Citrus medica* Linn. (citron), *Citrus nobilis* Lour. (Satsuma orange, Canton mandarin), *Citrus* sp. (small orange), *Citrus hystrix* DC. (wild lime), *Citrus mitis* Blanco (calamondin), and *Citrus japonica* Thunb.

This list is based on young plantings, and the order of attack will probably change somewhat as observations continue. A great variation occurs in the susceptibility of different varieties in the same species.

Citrus maxima (Burm.) Merr. (*Citrus decumana* Linn.) is most severely attacked when young. Older trees of native varieties grown by the Filipinos in the neighborhood of the college are attacked, but as with *Citrus nobilis* Lour. little damage is done.

Symptoms.—The characteristic appearance of the disease as it occurs on citrus is as follows:

Spotting is produced on leaves, stems, and fruit. At first the spots on leaves are small, round, watery, slightly raised dots. These dots enlarge, turn brown, extend through the leaf, become raised on one or both surfaces, and have ruptured surfaces. Concentric, irregular rings may be produced in the brown portion of the spots. A light yellow border is produced around the brown center. Frequently spots run together, producing an elevated, elongated, ruptured, brownish blotch (Plate III, fig. 2). In many cases a leaf-mining insect carries the infection through its winding gallery, or mine, in the form of a chain of canker spots (Plate III, fig. 3). This miner is the larva of a small moth, *Phyllocnistis citrella* Stainton, and is common throughout the Orient, being especially injurious to nursery stock.

On the twigs the spots are somewhat different. At first they are similar to those on the leaf, but later become irregular,

raised, spongy brown spots, often with a dark brown border. Spots are cankerous and persistent, but are only formed in the outer layers of the bark tissue. Frequently twigs are entirely encircled by cankers, but do not seem to be killed outright in all cases (Plate IV, figs. 1 and 2).

In the first stages of the disease the spots on the fruit are similar to those on the leaf. They may be scattered, but frequently run together, forming irregular, raised, brown cankerous blotches. The surface of the fruit is depressed or slightly wrinkled in the neighborhood of large blotches (Plate IV, figs. 2 and 3). Cankers do not penetrate deeply below the surface and seem to do little harm other than producing an unsightly appearance. Gumming of the fruit is associated with the disease in some cases, but this is not general.

Causal organism.—The bacteria causing this disease gain entrance to the host primarily through injuries. Citrus leaves, especially those of the highly spiny species, have many injuries due to the whipping of the leaves against the spines. The organism is spread throughout the tree primarily by rain. The bacteria grow well in pure culture, producing a yellow pigment.

Control.—The control of citrus canker is rather difficult. The orange, *Citrus nobilis* Lour., is the most commonly cultivated species in the Philippines and is relatively free from the disease; so no control measure need be applied for this species. Other species are, however, severely infected. For these control measures should be practiced. In order to obtain an effective control for citrus canker, persistent efforts must be used. This is true of the majority of bacterial diseases of fruit trees. A combination control of spraying and pruning out of the diseased portions will produce beneficial results. It is necessary, however, to be on the lookout for new infections, and these must immediately be removed. Monthly sprayings with Bordeaux mixture, to which a sticker has been added, is the most beneficial. Lime-sulphur must be applied in place of Bordeaux from time to time, in order to combat aphids and scale insects. In severe cases of infection it is advisable first to remove diseased leaves by spraying with a strong formalin spray (0.4 to 0.5 per cent), which will cause them to drop off.

CHLOROSIS: NONPARASITIC

Symptoms.—Frequently leaves on certain trees show a general yellowing in contrast to a definite mottling as produced in mottled leaf. In some cases this yellowing may cover the entire leaf, while in others large yellow blotches are produced. A

uniform yellowing of the leaves seems to be due to malnutrition, probably a lack of nitrogen. The yellowing in blotches may be due to the attacks of mites.

Control.—The disease may be avoided by using healthy stock and by the practice of proper culture methods. In case of insect attacks, these must be controlled by entomological methods.

DAMPING OFF: RHIZOCTONIA

Symptoms.—Seedlings grown in unsterilized soil and in poorly aërated places may be severely attacked, just at the ground surface, by this fungus, which first causes a browning of the stem and later a shrinking and weakening of the tissue, causing the plants to fall over and die. The disease is somewhat similar to, but more prevalent than, that produced by a *Sclerotium*.

Causal organism.—This organism is a common soil fungus causing a large amount of destruction to tender plants during periods favorable to its spread. It grows well in pure culture, first producing a coarse white mass of mycelium, which later turns brownish and produces a large number of brown sclerotial bodies. No spores have been observed. The fungus penetrates the plant tissues, causing the weakening and death of the cells.

Control.—Seedlings should be grown in sterilized soil and should be placed where there is plenty of chance for air.

DAMPING OFF: SCLEROTIUM

Symptoms.—Seedlings growing in damp and poorly aërated places are frequently attacked by a fungus that causes a rot resulting in damping off. The stem is attacked near the ground and becomes browned, shrunken, and weak, due to cell destruction. Plants in the latter stages of the disease fall over and die.

Causal organism.—Isolation and inoculation experiments show this disease to be due to a fungus that produces sclerotia. The fungus invades the tissues from the ground. Upon death of the plant small, round, smooth brown sclerotial bodies are produced. These bodies germinate directly by the production of mycelium. No spores have been observed. The same fungus may cause a damping off of coffee seedlings, cacao seedlings, and other plants. In pure culture a dense white growth is first produced, which later gives rise to a large number of round, smooth brown sclerotial bodies.

Control.—The disease is easily controlled by growing plants in well-aërated places, free from too great humidity. If the soil be heavily infected with the fungus, soil sterilization must be practiced.

DIE-BACK

Symptoms.—Die-back is common in poorly kept orchards and appears, in the main, to be due to a lack of nutrition. The symptoms are a gradual dying back of the branches, starting from the tip.

Causal organism.—No definite causal organism has been assigned. Many fungi are found on dead and dying twigs, including the following: On *Citrus nobilis* Lour.; *Zignoella nobilis* Rehm., *Cytospora aberrans* Sacc., *Eutypella citricola* Speg., *Hypoxylon atropurpureum* Fr. (on coccids), *Valsaria citri* Rehm., *Massarina raimundoi* Rehm., *Tryblidiella rufula* (Spreng.) Sacc., *Diaporthe citrincola* Rehm., *Diplodia aurantii* Catt., and *Tryblidiella mindanaensis* Henn; and on *Citrus maxima* (Burm.) Merr. (*Citrus decumana* Linn.); *Eutypella citricola* Speg. and *Eutypella heteracantha* Sacc. Growing on the latter fungus has been observed another fungus, *Nectria episphaeria* (Tode.) Fr.

Control.—Citrus culture in the Philippines is practiced in a slipshod manner. Die-back may be largely avoided by the use of correct culture methods. All dead and dying branches should be pruned out and burned.

EPIPHYTES: LORANTHUS PHILIPPENSIS CHAMISSO

Symptoms.—Epiphytes are sometimes found growing on trees in poorly kept plantations. They can be easily removed by pruning.

FRUIT ROT: LASIODIPLODIA THEOBROMAE (PAT.) GRIFFON ET MAUBLANC

Symptoms.—A dry rot of citrus fruit may take place due to the attacks of this common dry rot organism. Diseased fruits are characterized by a shriveled, dry appearance and are covered with a dense black sooty mass of spores.

Causal organism.—The organism gains entrance into the fruit through injuries. A series of pycnidia is produced just under the surface of the fruit, and from there, through openings extending to the surface, the spores are expelled in large numbers. The spores are, when immature, single-celled, hyaline, very granular, oval bodies. Upon reaching maturity, they become two-celled and dark brown. Germination takes place readily within a few hours in water. The spores may germinate before reaching the two-celled stage. The fungus grows well in pure culture, producing, on potato agar, a heavy growth of dark greenish to black mycelium. No spores have been observed in these cultures.

Control.—Care should be used in handling the fruit so as to keep it free from injuries.

FRUIT ROT: *PENICILLIUM*

Symptoms.—Fruit rots are present on fruit kept for some time out of storage. The *Penicillium* rot is characterized by the production of a green powdery mass of spores over the soft, rotted area. The rot starts at some injury and gradually spreads until the entire fruit is involved.

Causal organism.—The fungus penetrates the tissue of the fruit, causing a soft rot. It produces an abundance of typical *Penicillium* spores on the surface of the fruit. These spores blow from diseased to healthy fruit, thereby causing infection.

Control.—The fruit should be kept free from injuries. It should be used as soon as possible, and if stored it should be kept in a well-aërated place so as to avoid excessive moisture.

Phyllosticta circumsepta Sacc. has been found on the dying rind of fruit.

GUMMOSIS

Symptoms.—A gumming of the trunk, stem, and fruit occurs. Whether this is due to unfavorable climatic conditions, to lack of cultivation and care, or to parasites has not been fully determined. The disease of the stems is more severe in poorly kept orchards. Insect punctures in the fruit have been observed to result in a gumming; mechanical or fungus injuries, as in the case of citrus canker, may also cause a gumming. It appears that gummosis of stem and fruit here is not caused by any one definite organism or factor.

LICHENS

Symptoms.—Lichens are found in abundance, growing over all woody parts and even upon the leaves of trees, producing greenish gray blotches. The damage done appears to be slight; however, the normal physiological activities of the plant must be disturbed thereby.

Control.—Lichens can be reduced by the use of a spray or wash of 6 per cent copper sulphate solution or by judicious spraying, as discussed under citrus canker.

MOTTLED LEAF: NONPARASITIC

Symptoms.—Leaves thus diseased are characterized by a distinct yellowing of the leaf mesophyll between the large lateral veins. The tissue adjacent the midvein and the larger lateral veins is of a healthy green. Entire trees may be affected, but often only leaves on special branches are diseased. When the entire tree is affected, it is much dwarfed and may later die, due to secondary agencies. Badly diseased trees commonly show

witches'-broom effects and a more or less complete rosette of the leaves (Plate III, fig. 1).

Causal organism.—The disease is a nonparasitic one, being due to some disturbance of the normal physiological activities of the plant. It is not transmitted from one plant to another. Sometimes in marcotting, the disease is produced on branches the bases of which have been encircled with a bamboo tube or a coconut husk containing earth.

Control.—Since the disease is little understood, no definite control can be given. Badly affected trees should be removed, for they are stunted and will never produce healthy fruit.

PINK DISEASE: *CORTICIUM SALMONICOLOR* BERK. ET BROOME

Symptoms.—This disease may be severe during the rainy season in poorly kept orchards. The fungus is a common one, producing disease on other woody plants. Infection starts on the trunk or branches usually in some damp pocket. It is first noticed by the production of cracks and by an exudate of gum. As the fungus penetrates into the bark, it spreads under the surface and causes a more or less cankered condition. In the latter stages the bark cracks and dries up. The fungus may penetrate through the bark into the cambium and wood. When a branch or trunk of a small tree is girdled by the fungus and the xylem is invaded, the upper parts of the plant gradually die, due to starvation. Diseased trees are easily discovered by reason of the dead branches. The diseased area in certain stages of development, especially during the rainy season, is covered with a mass of pink mycelium that often extends over the bark in strands. During drier weather the mycelium dries considerably and is not so evident, as it changes to a dirty white or gray.

Causal organism.—No detailed work has been done with the fungus. It grows in pure culture, producing a matted mass of pinkish mycelium. The complete life cycle of the fungus has not been worked out.

Control.—Since healthy, vigorous trees are less liable to attack, proper cultural methods should be practiced. Spraying healthy trees as in the case of citrus canker will exclude the fungus. Once the fungus has gained entrance into and under the bark, spraying will do no good. Young infections may be removed by cutting out all the diseased portions well down into the healthy wood and painting the wound with a creosote paint or white lead. All badly diseased branches should be pruned out and destroyed by burning. These branches should be cut out 15 to 20 centimeters below the visible extent of the disease, for the mycelium

often penetrates farther than can be seen with the naked eye. All large wounds should be painted with a creosote paint or white lead. Severely infected trees should be cut down and burned immediately.

SCALY BARK

Symptoms.—A disease characterized by a scaling of the bark is common, but the causal factors have not been determined. The attacks of an insect just below the bark cause a sloughing, but this does not appear to be the only factor.

SOOTY MOLD: MELIOLA

Symptoms.—Frequently this sooty mold is found growing over leaves, stems, and fruit. It is superficial, growing on the sugary exudate of aphids. The fungus has been observed on *Citrus medica* Linn., *Citrus nobilis* Lour. and on *Citrus maxima* (Burm.) Merr. (*Citrus decumana* Linn.) and undoubtedly occurs on other *Citrus* species.

Causal organism.—A dense mass of brown mycelium, with its characteristic hyphopodia, is produced over the affected area. Setæ and dark brown spherical perithecia are produced from the mycelium (fig. 9). Within the perithecia are found the hyaline globular asci with from two to four typical, five-celled brown ascospores (fig. 9).

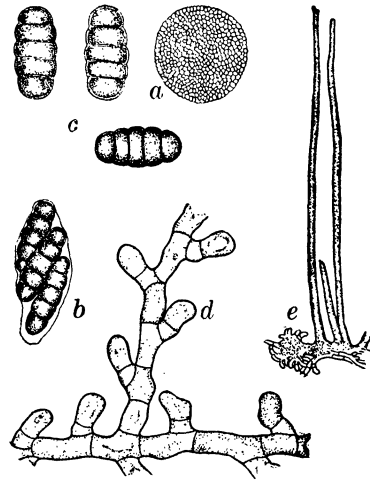

FIG. 9. *Meliola*, on *Citrus nobilis* Lour. a, perithecium (X 75); b, ascus (X 310); c, ascospores (X 310); d, mycelium with hyphopodia (X 310); e, setæ (X 75).

Control.—The disease may be controlled by spraying with lime-sulphur, which will keep the aphids under control as well as destroy the fungus.

SPINY MOLD: IMPERFECT FUNGUS

Symptoms.—A spiny mold may be produced on leaves, stems, and fruit. Black tufted masses of fungus appear in spots or frequently in masses, covering the entire affected portions. The fungus grows primarily on the exudate from aphids.

Causal organism.—A dense mass of brown mycelium, with numerous setæ, is produced. The setæ are septate and much elongated and they give the tufted appearance. Hyaline, elongated

ate, sometimes crescent-shaped granular spores are produced among the setæ. The fungus has not been identified.

Control.—The control is similar to that discussed under sooty mold of citrus.

WITHER TIP: COLLETOTRICHUM GLOEOSPORIOIDES PENZIG

Symptoms.—A gradual dying of twigs and branches is frequently produced by this fungus. Not only the twigs, but the leaves and the fruit may be infected. The leaves wither, and the twig is killed and shrinks, leaving a definite line of demarcation between healthy and diseased wood. On the leaf, dark brown spots are produced. The fruit beneath a withered tip branch often becomes infected, which is evidenced by a russet appearance. Minute black specks are produced over the diseased surface.

Causal organism.—The organism is evidenced by the acervuli, produced in the form of black specks over the diseased parts. The acervuli are formed under the surface, but later rupture it. Setæ are produced, and from a dense mass of short conidiophores are produced the minute, cylindrical, granular hyaline spores. The fungus grows well in pure culture, producing scanty mycelium, from which arise many small black fruiting bodies.

Control.—All diseased portions should be removed by pruning out well below the visible advance of the disease. Spraying with Bordeaux mixture as discussed under citrus canker is effective.

Gloeosporium intermedium Sacc. is found on injured citrus leaves, where it produces minute black specks in the gray injured portions. *Aschersonia sclerotoides* Henn. may be found growing parasitically on coccids that are on the leaves. A *Micropeltis* also may be found growing on leaves.

COCOS NUCIFERA LINN. COCONUT

BUD ROT: BACTERIAL

This is the most serious coconut disease in the Philippine Islands, if not in the world. Fortunately it is severe only in a few localities of the coconut regions, chiefly in Laguna, Batangas, and Tayabas Provinces. These coconut sections are some of the most extensive in the Islands and, unless control measures are carried out, the disease will spread.

Symptoms.—The first symptom is a withering of the youngest unfolded leaf, followed by the leaf's turning brown. Gradually other leaves wither and turn brown, until the entire central group is affected. At this stage the disease is easily recognized by the group of dead young leaves of the central bud, which has

become brown. Often some of the largest leaves of the bud fall over (Plate V, figs. 1, 2, and 3). This diseased central portion is surrounded by older leaves, on the outside, which are perfectly healthy and remain upon the tree until they drop off naturally. Trees are more commonly affected when they first come into bearing. The young nuts, on bearing trees attacked by the disease, remain small and fall off prematurely. Trees are affected most generally in regions of great moisture and in overcrowded areas.

Internal symptoms of diseased trees are very characteristic. A longitudinal section of the bud shows, in new cases, that the disease may start in the young leaves, at a point where they begin to unfold (Plate VI, fig. 1). At this point a spotting of the leaf is first noticed, then the organism works downward, causing a soft rot and browning of the group of unfolded leaves. The upper exposed portions of these leaves die and turn brown, due to the rotting beneath. The rot advances downward through the young leaves to the growing point and then spreads into the soft tissue below. From here it invades the woody tissue, usually not penetrating farther than from 5 to 10 centimeters. In the early stages of the disease no discoloration is produced in the growing point and cabbage, but a dark red to brownish ring always limits the advance of the disease in the wood on bottom and sides (Plate VI, fig. 4). The disease does not penetrate readily into the old leaf sheaths surrounding the young, tender, developing leaves (Plate VII, figs. 1, 2, and 3).

The rot is checked, as a rule, when it reaches the firmer tissues of the trunk, penetrating, in advanced cases, about 20 centimeters (Plate VI, figs. 2 and 3). The softness of the affected portion in the trunk is shown by the fact that the finger can be pushed into the diseased part. A vile, somewhat sour odor accompanies the disease. The most advanced stages of the disease are characterized by the white cabbage changing into a, semiliquid mass with an ill-smelling odor. The diseased portion of the trunk becomes a mass of fibers and a semiliquid.

The disease spreads very rapidly from tree to tree, but the manner of spread is not fully understood. Insects are undoubtedly one of the factors to be considered in its transport from infected to healthy trees. In one barrio under observation, fifty-eight new infections appeared within one year after an inspection in which all trees found with the disease were cut down and burned. Infection must have started from one or a few trees unobserved during this first inspection. These trees are located in the upper extremity of the coconut region on the

slopes of Mount Banahao, where it is very damp. The trees are also planted too thickly. Both these factors are favorable to the development and spread of the disease.

Causal organism.—Microscopic examination of diseased tissues taken from typical young cases of bud rot showed no evidence of mycelium, but an abundance of bacteria. Diseased pieces collected under sterile conditions in the field and placed immediately into sterile vials developed no fungi; however, they were completely invaded with bacteria. Many fungi would develop from older diseased portions when placed in a moist chamber, but under no conditions was one specific organism always produced.

Careful inspection was made of over thirty typical cases of diseased trees. These trees were cut down and the bud opened for observation. In all cases the disease appeared to be due to bacteria. Isolations were made from sixteen different typical cases.

Cultures were obtained by cutting and plating out, under sterile conditions, small pieces from all parts of infected trees, from the tip of the unfolded infected leaves down to the growing point and into the wood below. Poured plates from these cultures showed that in the majority of cases a mixed culture of bacteria was present. In very young cases of infection, however, only one organism is present. The latter cases are hard to obtain, because saprophytic bacteria find a favorable place for development in the infected portion, and they are soon washed down into these parts. In order to prove the virulence of the bacteria isolated, a large series of inoculations was carried out.

These inoculations were made chiefly with seedling coconuts. The plants were from 60 to 180 centimeters tall. They were carefully prepared for inoculation by stripping off the outermost, older leaves. Then the portion to be inoculated was washed with mercuric bichloride, 1 to 1,000. With sterile scalpels, stabs were made into the growing point, and the pure cultures of bacteria were introduced. The injuries were then covered with paraffin. Over two hundred inoculations have already been carried out in this fashion and typical cases of bud rot produced (Plate VI, figs. 5 and 6). The first inoculations were not repeatedly positive, because they were made outside during the excessively dry season, under which condition the organism is not extremely virulent. In later inoculations made in a specially constructed damp chamber, the disease could be produced at will with the correct organism. By this method all the saprophytic bacteria were eliminated. Inoculations with fungi also proved negative.

After this eliminating process, there was left one distinct organism that would produce the disease. At least 75 per cent of positive infections can be obtained under proper conditions. This one organism has been carried through a series of three different plants by inoculation, reisolation, and reinoculation.

The organism produces white colonies with a bluish tinge. Since *Bacillus coli* (Escherich) has been associated with the disease in Cuba and since the organism isolated here in the Philippines appears to be somewhat similar to *Bacillus coli* (Escherich), inoculation experiments were carried out with the latter organism.

Authenticated cultures of *Bacillus coli* (Escherich) obtained from the United States and also cultures obtained from the Philippines were used. The cultures from the United States were isolated from man, those from the Philippines were isolated from man and horse. A bud rot was produced with each of these cultures. The rot produced from the first inoculation was very slight, but the organism reisolated and then reinoculated produced a rapid and severe case of rot. The initial inoculation was rather difficult to obtain, except in cases where the tissues of the coconuts were severely injured. This indicates that these bacteria must first pass through a weakened host before they become extremely virulent.

As yet culture studies have not progressed far enough to assign a definite name to the organism isolated from coconuts here in the Philippines, but investigation has shown that there is a bacterium that causes the bud rot of coconuts. A complete and detailed account of these investigations will be soon published.

Cytological studies show only the presence of bacteria. Sections from a typical case of bud rot were made from diseased portions obtained from the young leaves leading to the growing point, from portions of the growing point, from the cabbage, and in the wood. These sections show that the organism is not

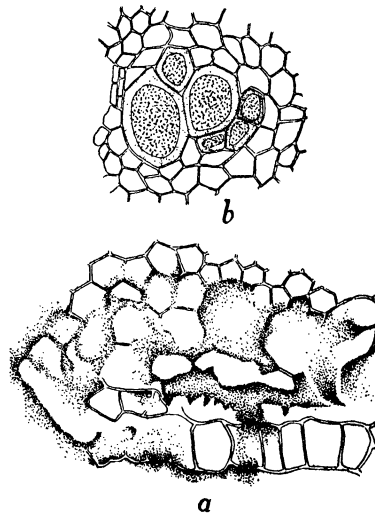

FIG. 10. Bud rot of coconut. *a*, cross section of infected portion of young unfolded leaf, showing mass of bacteria in tissue ($\times 425$); *b*, cross section of infected portion of young unfolded leaf, showing mass of bacteria in xylem tubes of a vascular bundle ($\times 330$).

only present in the parenchymatous tissue, but also that the chief means of spread in the plant is through the vascular system. Xylem tubes in the young leaves and in all portions down to the woody tissue are infected (fig. 10). This accounts for the rapid advance of the disease in the tissue.

Control.—Trees when once affected never recover. The mode of growth of the palms and the nature of the disease make it impossible to cure trees already infected. The only control so far determined is one of prevention of spread. All diseased trees should be cut down, and the diseased portions should be completely burned or deeply buried after sprinkling with lime. If this precaution of burning all infected trees be carried out under strict supervision, the danger of spread is largely eliminated.

The greatest factors in the severity of the disease are the growth of coconuts in excessively damp places and in extremely thick plantings. New plantings should be made only in those localities that are best suited for coconut growth and development. Plantings should not be too thick. The recognized distance for plantings for the best production and at the same time for the best control against bud rot is 10 meters each way.²

LEAF SPOT: EXOSPORIUM DURUM SACCARDO

Symptoms.—A spot that is not common and causes little damage. It is characterized by the production of black tubercular or wartlike bodies, the sporodochia, on the surface of leaves. These spots are scattered, sometimes densely, over the leaf surface. In some cases the sporodochia may be surrounded by a light yellowish discoloration of the leaf (Plate VIII, fig. 4).

Causal organism.—The wartlike bodies, or sporodochia, have no spines. The conidia are borne on conidiophores and are yellowish to brown and septate.

Control.—Since the disease is not severe, no special control need be practiced. All fallen diseased leaves should be collected and burned, so as to avoid a spreading or an epidemic.

LEAF SPOT: PESTALOZZIA PALMARUM COOKE ET GREVILLE

Symptoms.—This disease is common throughout all coconut regions. As a rule, it is not severe and causes little damage. The vitality of the tree is lowered, and in a few cases, especially on younger trees, the spotting may become severe. Spots often are scattered over the entire leaf surface. Young infections are characterized by small brown to black, elevated, circular spots a

² See Copeland, E. B., *The Coco-nut*. London, Macmillan and Co. (1914).

few millimeters in diameter. Older spots are irregular-circular to slightly oblong, may run together, and are from 1.5 centimeters to 2 or 3 centimeters long. These spots have a light brown to ashen-gray center and are bordered with a narrow dark brown ring (Plate VIII, fig. 3).

Causal organism.—In the gray parts are produced the characteristic minute black acervuli, which contain the spores. Spores are septate, with central brownish cells and hyaline end cells. Two to four hyaline appendages are produced at one end of the spores and usually only one at the other end (fig.

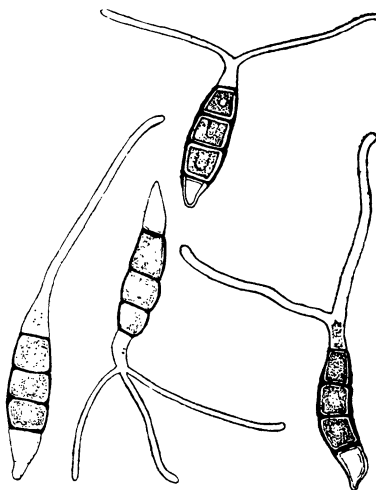

FIG. 11. *Pestalozzia palmarum* Cke. et Grev. Conidia, showing characteristic appendages ($\times 990$); from pure culture.

11). The fungus grows well in pure culture, producing, on potato agar, at first a felty mass of white mycelium, which later becomes studded with the black spore bodies. The agar in old cultures turns brownish.

Control.—In severe cases of infection of young trees, spraying with Bordeaux mixture is effective. Sanitation in the form of burning dead and diseased leaves is the usual control.

SOOTY MOLD: CAPNODIUM FOOTII BERKELEY ET DESMAZIÈRES

Symptoms.—A sooty mold is often developed on the under surface of the leaves. This is produced by the fungus growing on honey dew of coccids; this mold is not at all serious.

STERILITY OF NUTS

Symptoms.—Frequently nuts are found that are entirely composed of husk. No meat or shell is developed within the husk (Plate VIII, fig. 1). The disease is undoubtedly a nonparasitic one, being due to some abnormal physiological condition of the plant.

OTHER FUNGI

Other fungi found upon the coconut include the following: *Chaetosphaeria eximia* Sacc. and *Phyllosticta cocophylla* Pass. on dying leaves; *Anthostomella cocoina* Syd., *Diplodia epicocos* Cooke, and *Coprinus fimbriatus* B. et Br. on dead petioles; *Palawania cocos* Syd., *Hormodendron cladosporioides* (Fr.) Sacc.,

and *Coniosporium dendriticum* Sacc. on dead spathes; *Coprinus friesii* var. *obscurus* Pat. on dead sheaths; *Rosellinia cocoes* Henn. on dead peduncles; *Eutypella cocos* Ferd. et Winge., *Diplodia cococarpa* Sacc., *Diplodia epicocos* Cooke var. *minuscula* Sacc., *Diplodia cococarpa* var. *malaccensis* Tassi., *Cytospora palmicola* B. et C., and *Peroneutypella cocoes* Syd. on husks; *Elfvigia tornata* (Pers.) Murr. and *Ganoderma incrassatum* (Berk.) Bres. var. *substipitata* Bres. on dead trunks; and *Gloeoglossum glutinosum* (Per.) Durant. on base of living tree.

COFFEA SPP. COFFEE

DAMPING OFF: RHIZOCTONIA

Symptoms.—A damping off and stem rot of seedlings similar to that discussed under citrus is found on coffee. Diseased plants have browned stems, which shrink and cause the plant to fall (Plate XIII, fig. 1).

Causal organism.—The causal organism is the same as discussed under citrus stem rot.

Control.—Seedlings should be grown in sterilized soil and in well-aërated places.

DAMPING OFF: SCLEROTIUM

Symptoms.—Coffee seedlings are frequently attacked on the stem just at and above the ground by a *Sclerotium* that causes a damping off. Infected stems are blackened and somewhat shrunken. The fungus may also spread to the leaves, causing an advancing black rot. Spherical brown sclerotial bodies may be produced on infected portions. The disease is most severe during the rainy season and on seedlings kept in damp places. Young plants are killed by the attack.

Causal organism.—In pure culture the fungus produces numerous small, smooth, spherical brown sclerotial bodies. Infection experiments have proved the virulence of the fungus isolated, but as yet all attempts to produce spores have failed. This fungus is the same as that which may cause a stem rot and damping off of citrus seedlings.

Control.—The disease is only severe when plants are grown in poorly aërated places. Seedlings should be grown in sterilized soil and well-ventilated locations.

FOOT ROT

Symptoms.—A rot of the trunk of older coffee trees may take place at the surface of the ground. The entire trunk of the plant is girdled, resulting first in a yellowing of the leaves and then in a gradual wilting and death.

Causal organism.—No organism has as yet been associated with this disease. Consequently no definite control can be given.

LEAF SPOT: MICROPELTIS MUCOSA SYDOW

Symptoms.—A leaf spotting that is found on *Coffea excelsa* Cheval. and is only of slight importance. Minute, scalelike,

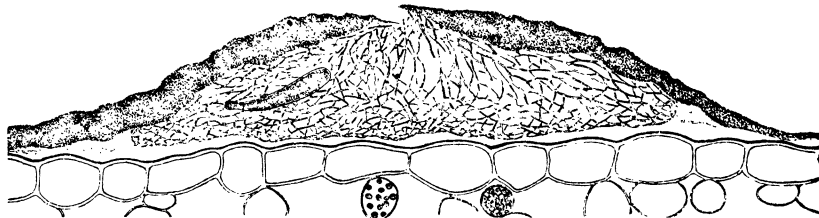

FIG. 12. *Micropeltis mucosa* Syd. Immature perithecium ($\times 335$). The fungus does not penetrate leaf tissue.

raised black spots are scattered over the upper and lower leaf surface. They are usually more abundant on the lower surface.

Causal organism.—These scalelike black bodies are perithecia, within which are borne the asci and ascospores. The asci are clubshaped and contain six to eight hyaline three- or four-celled ascospores. The fungus is a superficial grower and does not penetrate into the leaf tissue (figs. 12 and 13).

Control.—The disease does little or no damage; consequently no control measures need be practiced.

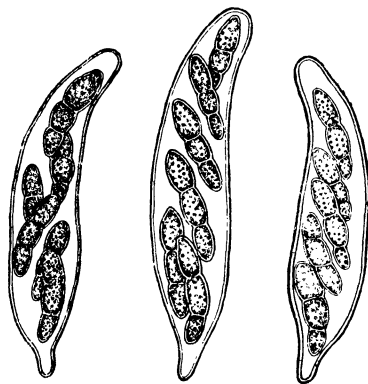

FIG. 13. *Micropeltis mucosa* Syd. Asci with ascospores ($\times 340$).

RUST: HEMILEIA VASTATRIX BERKELEY ET BROOME

Symptoms.—This widely distributed and destructive disease has wiped out the coffee industry in various sections of the Islands. Circular or subcircular orange-red spots cover the under surface of leaves. Infected leaves wilt and drop, repeated attacks causing death to the entire plant. Young spots appear as transparent slightly yellowish discolorations. As the spot becomes older, the yellow increases, until finally a yellow dust, which turns to orange, is produced on the under surface of the leaves. The disease is most severe and evident during the rainy season.

Coffea arabica Linn., the best commercial coffee in this section,

is severely attacked by the rust and has been practically wiped out in most regions. A few favorably situated districts, in high altitudes, still produce Arabian coffee successfully. Owing to *Hemileia*, *Coffea arabica* Linn. is now of relatively slight importance in Java. Many plantations have been uprooted and replanted to *C. robusta* or hybrid varieties.

Causal organism.—The orange dust on the under surface of

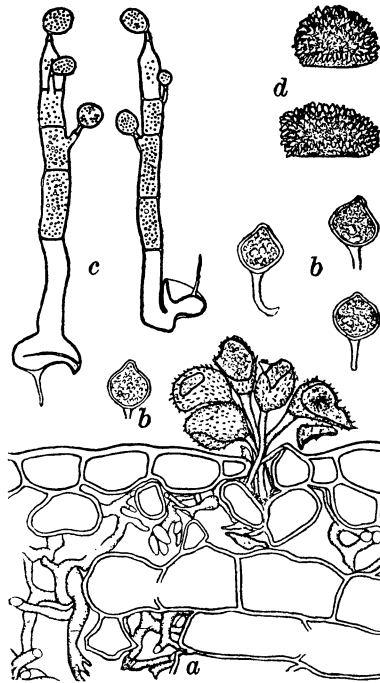

FIG. 14. *Hemileia vastatrix* B. et Br. a, infected coffee leaf, showing mycelium in tissue and production of uredospores some of which were cut in sectioning ($\times 325$); b, teleutospores ($\times 325$); c, germinating teleutospores, promycelia, and sporidia ($\times 325$); d, uredospores ($\times 325$).

leaves is made up of the single-celled irregular uredospores and few single-celled teleutospores. The uredospores are irregularly obovate, bilateral, with short, blunt spines on the dorsal surface and with the ventral side smooth. They are produced on the leaf surface from stalks projecting through the stomata (fig. 14). The uredospores germinate readily in water. Penetration takes place by way of the stomata. The mycelium grows in abundance in the air spaces and in the intercellular spaces of the leaf tissue. Teleutospores are not produced in abundance. They are small, pale yellow, and smooth and have a short, slender, hyaline pedicel. They germinate often on fallen leaves by the production of a promycelium with sporidia (fig. 14).

Control.—Control consists in selecting resistant varieties and in spraying with Bordeaux mixture. As yet no resistant strain of *Coffea arabica* Linn. has been

developed. In the Philippines, as shown by the College of Agriculture plantings, *Coffea robusta* is only slightly attacked and *Coffea arabica* Linn. is severely attacked. The *liberica* varieties need a special pulper, and the *robusta* coffee is of relatively poor quality and commands a lower price. The *arabica* coffee, *Coffea arabica* Linn., is the most easily handled and is very productive;

therefore, for the Philippines, the best control measure for this variety is spraying. Spraying experiments have shown that the disease can be controlled with Bordeaux mixture at a cost of 10 centavos³ a tree per year.

SOOTY MOLD: AITHALODERMA LONGISETUM SYDOW

Symptoms.—A black sooty mold may be produced over the surface of leaves. Little injury is done, as the organism is not abundant.

STEM DISEASE

No important stem diseases on older plants have been observed. *Coniothyrium coffeae* Henn. has been found on twigs of *Coffea arabica* Linn.

COLOCASIA ESCULENTUM SCHOTT (COLOCASIA ANTIQUORUM SCHOTT). GABI

BLIGHT: PHYTOPHTHORA COLOCASIAE RACIBORSKI

Symptoms.—Gabi, which is extensively grown in the Philippines, suffers severely from the attacks of this fungus. Leaf blade, petiole, and corms are attacked. Leaf spots appear at first as small, roundish dark brown spots. They rapidly increase in size, may be circular, oval, or often running together, until finally the entire leaf is diseased. Spots are not confined to the portion of the leaves between main veins, but readily cross the latter. Spots 2 to 3 centimeters in diameter are dark and rather watery and produce drops of a yellow liquid. Older and larger spots have yellowish brown centers bordered by broad watery rings. Frequently the margins have concentric brown or yellow rings (Plate XV, fig. 1). When spots coalesce, covering the entire leaf, a soft, watery, disintegrating leaf is produced.

In severe cases the petioles may become infected. The fungus gradually invades the petiole, which becomes blackened, shrunken, and watery and finally collapses. The entire diseased leaf then decomposes into a watery mass.

Infection of the corm may occur in severe attacks and during damp weather. Diseased corms disintegrate with a wet rot. The disease is most severe during the rainy season.

Causal organism.—A downy mass of spores is not produced on the diseased spots, but only a delicate white growth can be detected. This is made up of the conidia produced on short

³ One peso Philippine currency equals 100 centavos, equals 50 cents United States currency.

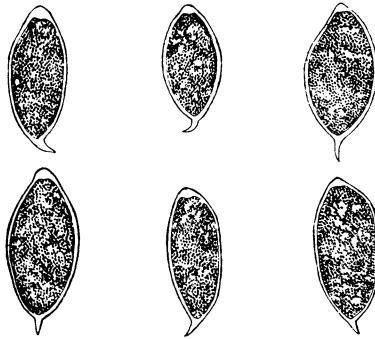

FIG. 15. *Phytophthora colocasiae* Rac.
Conidia (× 330).

conidiophores. The conidia are large, thin-walled, smooth, and colorless and have short, broad papillæ (fig. 15). No oöspores have been observed. Infection takes place by the conidia, which are scattered chiefly by water.

The fungus grows readily in pure culture and can be easily isolated by the simple method of plating out diseased portions on potato agar. A downy mass of white mycelium develops on

potato agar slopes, and conidia are formed in abundance. Sexual spores are produced in pure culture.

Inoculation experiments, in a damp chamber, produce typical leaf spots in two to three days.

Control.—Control consists in the growing of disease-resistant varieties. Spraying with Bordeaux mixture is effective.

Xanthosoma sagittifolium Schott, a heavy-yielding yautia, is not attacked by the *Phytophthora* and should replace the ordinary gabis.

CUCUMIS SATIVUS LINN. CUCUMBERS

DOWNY MILDEW: PLASMOPARA CUBENSIS (B. ET C.) HUMPHREY

Symptoms.—Yellow spots are at first produced on leaves. The whole leaf then turns yellow, shrivels, and soon dies. Central parts of older spots become dead and brittle and are a light brown. The disease starts with the older leaves and advances to the younger ones. Few cucumbers are produced on diseased plants.

Causal organism.—The typical branched conidiophores are produced singly or in small clusters from the stomata. Conidia are oval and light brown to violet-tinted.

Control.—Spraying with Bordeaux mixture should be done in severe cases of infection.

LEAF SPOT: CERCOSPORA

Symptoms.—Irregular to angular light greenish leaf spottings are found upon cucumbers. The spotting is not severe.

CUCURBITA MAXIMA DUCH. CALABAZA, SQUASH

DOWNY MILDEW: PLASMOPARA CUBENSIS (B. ET C.) HUMPHREY

Symptoms.—This disease is similar to that discussed under *Cucumis sativus* Linn.

POWDERY MILDEW: ERYSPHACEAE

Symptoms.—A white powdery mass may be produced on the leaves. The disease is similar to that discussed under papaya and tomato.

Causal organism.—Typical conidia and conidiophores of the Erysiphaceae are produced.

Control.—Powdering with sulphur in severe cases of infection will check the disease.

DAUCUS CAROTA LINN. CARROT

STEM ROT: RHIZOCTONIA

Symptoms.—During damp weather a stem rot of the carrot may be abundant. The stems are attacked just at and above the ground. Infected stems become brown, shrivel up, and cause the death of the leaf by cutting off the water supply.

Causal organism.—Isolations and pure culture work showed the causal organism to be a *Rhizoctonia*.

Control.—Avoid planting during the excessively rainy season.

DIOSCOREA ESCULENTA (LOUR.) BURKILL. YAMS

LEAF SPOT: CERCOSPORA UBI RACIB., CERCOSPORA PACHYDERMA SYDOW

Symptoms.—Leaves may be moderately spotted with spots of the *Cercospora* type. Little injury is done.

LEAF SPOT: ELLISIODOTHIS REHMIANA THEISS ET SYDOW (PHYLLACHORA DIOSCOREAE SCHWEIN, PHYLLACHORA REHMIANA THEISS ET SYDOW)

Symptoms.—Shiny black stroma are scattered over infected leaves. Little damage is done.

RUST: UREDO DIOSCOREAE (BERK. ET BRM.) PETCH., UREDO DIOSCOREAE-ALATAE RACIBORSKI

Symptoms.—A common leaf trouble, which at times is serious. Characteristic yellowish rust pustules are developed on the under surface of leaves.

STORAGE ROT: LASIODIPLODIA THEOBROMAE (PAT.) GRIFFON ET MAUBLANC

Symptoms.—Storage rots are present in abundance. This rot is characterized by the production of a sooty black mass of spores on the surface of dry-rotted roots.

Causal organism.—The organism causes a dry rot of a large number of root crops. It is more fully discussed under dry rot of cacao.

Control.—Avoid injuries in digging. Store in a well-aërated place. All diseased roots should be sorted out and burned.

A *Rhizopus* may also cause a rot.

Phoma oleracea Sacc., *Gloeosporium macrophomoides* Sacc., and *Phomopsis dioscoreae* Sacc. are found on dead stems.

Phyllosticta graffiana Sacc. and *Mycosphaerella dioscoreicola* Syd. are found on leaves of *Dioscorea esculenta* (Lour.) Burkill.

DOLICHOS LABLAB LINN. LABLAB BEAN

LEAF SPOT: CERCOSPORA

Symptoms.—Round gray-centered spots with purplish borders may be scattered over the surface of leaves. Little damage is done.

Causal organism.—Typical, elongate, septate, tapering *Cercospora* spores are produced on light brown conidiophores. The latter are formed in groups from the stomata.

Control.—Crop rotation will reduce the prevalence of the disease.

ORANGE GALLS: WORONINELLA DOLICHI (CKE.) SYDOW

Symptoms.—This disease is similar to that discussed under *Psophocarpus tetragonolobus* DC.

Septoria lablabis Henn. and *Septoria lablabina* Sacc. may be produced on weakened mature leaves. *Diplodia lablab* Sacc. is produced on the stems.

On dead Kultha beans, *Dolichos uniflorus* Lam., may be found the following: *Vermicularia horridula* Sacc. and *Didymella lussoniensis* Sacc.

FIGUS CARICA LINN. FIG

RUST: KUEHNEOLA FIGI (CAST.) BUTL. (UREDO FIGI CAST.)

Symptoms.—A disease that may be very severe, causing defoliation, especially during the rainy season. Raised brownish sori are produced on the under surface of the leaf. Often the under surface is covered with a rusty powder composed of spores. Small yellowish spots are produced on the upper surface of the leaf above each sorus on the under surface.

Causal organism.—Usually cushion-shaped, light brown, spiny uredospores only are produced. Teleutospores are smooth, in chains, and with the germ pores apical.

Figs are not grown commercially in the Philippine Islands. Wild figs, of which there are many species in the Islands, have the leaves commonly spotted with the characteristic stromata produced by the genus *Phyllachora*.

GLYCINE MAX (LINN.) MERR. (GLYCINE HISPIDA MAXIM.). SOY BEAN, SOJA

BLACK MILDEW: TROTTERIA VENTURIOIDES SACCARDO

Symptoms.—Frequently entire patches of soy beans appear yellowish and sickly. This may be due to a fungus that makes

itself evident by the production of numerous, small black specks on the under surface of the leaves. Serious damage may be produced.

Causal organism.—The pycnidia are brown, with conspicuous wall markings, and they bear spines. Conidia are elongate, somewhat tapering, often curved, five- to seven-celled, and hyaline.

Control.—Crop rotation should be practiced.

BLIGHT: RHIZOCTONIA

Symptoms.—During the rainy season entire fields may be wiped out, due to this common soil fungus (Plate IX, fig. 1). The disease is most severe in close plantings. Soy beans are not the only plants attacked. All other beans and apparently every plant growing in a matted condition may be attacked. Aside from being found on beans, the disease has been observed on African peanuts, *Voandzeia subterranea* Thou., and on weeds growing among infected plants. Beans and other plants that can be grown on trellises, so as to keep them off the ground, and plants grown where they are not crowded, thereby permitting of sufficient aëration, are less subject to the disease.

Stems, leaves, and pods are all severely affected. The disease starts from the ground, growing up the older hardy stem to the tender portions or attacking the tender portions directly if they touch the ground. The mycelium of the fungus can be easily seen growing over the plants in a whitish mass and spreading from plant to plant. Infected leaves are at first somewhat yellowed in blotches, and gradually they turn black and disintegrate into a soft mass. Diseased plants touching healthy plants will afford a means of spread. From infected leaves the disease spreads to the tender stems and even to the more mature stems, causing them to decay and to turn into a watery mass. As the leaves and stems disintegrate, and especially during drier weather, countless numbers of sclerotial bodies are produced (Plate IX, fig. 3). These sclerotial bodies at first are white and soft, but soon turn brown and hard. They are sometimes roughly spherical, from 1 to 3 millimeters in diameter, or they may be somewhat flattened and elongated, often 6 millimeters in length (Plate X, fig. 3). The diseased leaves and sclerotial bodies fall to the ground, whence the latter produce mycelia during favorable weather and attack plants as before described. The disease is not severe during the dry season nor during the drier weather in the rainy season. It spreads with remarkable rapidity during damp weather.

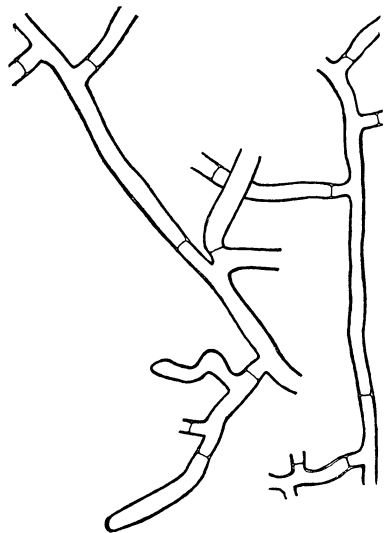

FIG. 16 *Rhizoctonia*. Mycelium from pure culture of fungus ($\times 340$), isolated from *Glycine max* (Linn.) Merr. (*G. hispida* Maxim.). Note characteristic branching.

diseased plants. The advance of the fungus can be retarded or completely stopped by removing the bell jars and putting the plants in the sun. Reisolation from infected plants produced the same fungus used for inoculation. At no time in diseased fields or on pure cultures have spores been observed. Attempts to produce spore-bearing bodies and spores from sclerotial bodies have thus far failed. The mycelium is typical of *Rhizoctonia* (figs. 16 and 17).

In the cross inoculations cultures obtained from *Glycine max* (Linn.) Merr. (*Glycine hispida* Maxim.), *Voandzeia subterranea* Thou., and *Phaseo-*

Causal organism.—The fungus mycelium penetrates to all diseased portions, undoubtedly producing an enzyme, which aids in disintegration. Numerous inoculation experiments have been carried on, using different beans as hosts. Sclerotial bodies from pure cultures were merely placed on leaves or tender stems, and the plants were put under bell jars. Within two days infection and blight were produced. Sclerotial bodies produce mycelia direct and infect injured or uninjured portions. Within one week the entire plant is blighted and falls over in a soft mass (Plate IX, figs. 2 and 3). Later sclerotial bodies are formed on these

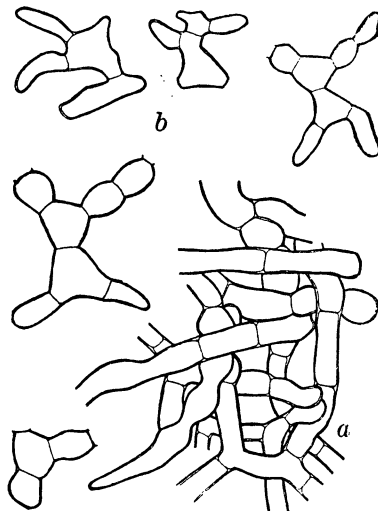

FIG. 17. *Rhizoctonia*. Mycelium from sclerotial body, growing in pure culture ($\times 340$); a, formation of sclerotial body; b, portions of sclerotial body. Isolated from *Glycine max* (Linn.) Merr. (*G. hispida* Maxim.).

lus calcaratus Roxb. all produced typical disease on *Phaseolus lunatus* Linn., *Phaseolus vulgaris* Linn., and *Phaseolus calcaratus* Roxb., which shows that the organism causes a general blight of beans under suitable conditions.

Further inoculation experiments show that under suitable conditions this organism may attack and kill a large number of succulent plants (Plate X, fig. 1). A pure culture isolated from soy beans killed the following seedlings in an experiment carried out in a damp chamber: *Glycine max* (Linn.) Merr. (*Glycine hispida* Maxim.), *Voandzeia subterranea* Thou., *Zea mays* Linn., *Capsicum* spp., *Carica papaya* Linn., *Citrus maxima* (Burm.) Merr. (*Citrus decumana* Linn.), *Coffea arabica* Linn., *Anona squamosa* Linn., *Hibiscus sabdariffa* Linn., *Nicotiana tabacum* Linn., *Saccharum officinarum* Linn., and the woody seedlings *Passiflora quadrangularis* Linn., *Lonchocarpus* sp., and *Caesalpinia sappan* Linn. Seedlings only slightly attacked were *Eugenia uniflora* Linn. and *Tamarindus indica* Linn.

A coarse, dense mass of whitish mycelium is at first produced in pure culture. Later whitish bodies of mycelium develop, which enlarge and become hard brown sclerotial masses. The sclerotial bodies are connected by fibrils.

Control.—Since the disease is only severe during excessively damp weather, in thick planting and where plants form a mat over the ground, control consists in avoiding these conditions. Planting should be done so as to escape the heavy rainy season. Inasmuch as sclerotial bodies fall to the ground and remain alive for a long period, crop rotation will have to be practiced. In this crop rotation plants should be grown that do not form a mat over the ground. Care should be taken that no sclerotial bodies are sown with the seed.

DOWNY MILDEW: PERONOSPORA

Symptoms.—Light green blotches may be produced on the leaves. These spots are due to the destruction of the chlorophyll by the presence of the fungus. Young leaves are often wrinkled because of the more rapid growth of the cells about the points of infection. A light purplish to white downy growth is produced on the under surface of diseased leaves.

Causal organism.—This purplish growth is made up of large numbers of much-branched conidiophores at the tips of which the spores are produced. The conidia are somewhat ovoid and hyaline (fig. 18).

Control.—Crop rotation should be practiced.

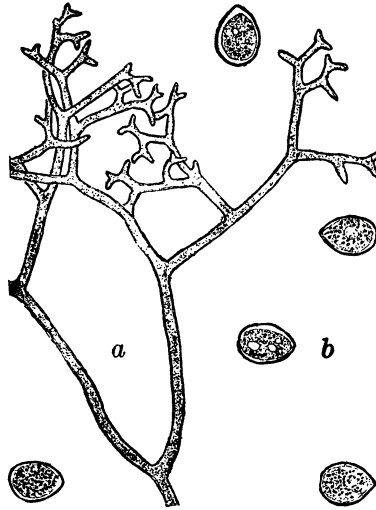

FIG. 18. *Peronospora*, on *Glycine max* (Linn.) Merr. (*G. hispida* Maxim.). *a*, portion of typical branched conidiophore ($\times 320$); *b*, conidia ($\times 320$).

RUST: UROMYCES SOJAE SYDOW

Symptoms.—Frequently soy beans may be severely attacked by this rust fungus. Characteristic brown rust sori are scattered thickly on the under surface of leaves. Spots are at first circular, raised brown blisters, but later burst open, exposing the spores. The upper surface of diseased leaves is yellowed above the sori on the lower surface.

Causal organism.—Irregular, short, spiny brown uredospores are produced in the rust sori (fig. 19).

Control.—Crop rotation should be practiced.

GOSSYPIUM SPP. COTTON

ANGULAR LEAF SPOT: BACTERIUM MALVACEARUM ERW. SMITH

Symptoms.—The disease is present on leaf, stem, and fruit. On the leaf the characteristic spots are from 1 to 4 millimeters in diameter; they are angular, with brownish centers bordered with light brown to yellow. Young spots are smaller and have a water-soaked appearance. They can be more easily detected on the lower surfaces of the leaves. Spots may run together forming brownish blotches which later become brittle. The dead brown tissue may fall out of the spots. Badly attacked leaves wither, die, and fall to the ground. The disease may be evident on the tender stalks in the form of blackened cankerous patches. On the bolls, at first, minute water-soaked spots are produced, which later may run together, producing sunken brownish or reddish brown blotches. If the bolls are young when attacked, the contents may be consumed; but on older bolls only the outer layers are invaded, producing little injury to the fiber. Young seedlings may be attacked first on the leaf from where the



FIG. 19. *Uromyces sojae* Syd. Uredospores ($\times 315$).

disease may spread to the stem, causing a blackened, water-soaked, weakened stem which finally falls over. In some cases, on older seedlings, only blackened blotches are produced. These may run together and girdle the stem, resulting in the falling over of the seedling.

Causal organism.—The causal organism is a bacterium that produces a yellow pigment in pure culture. It gains entrance into the plant through stomata and injuries. The organism may live over on the seed and lint for at least four months. It may also live in the soil for a considerable period.

Control.—The chief control consists in killing the organism on the seeds before planting. The seeds should first be delinted in sulphuric acid and then treated in hot water at 72° C. for eighteen minutes. In severe cases of plant infection, spraying with Bordeaux mixture will reduce the number of infected plants.

RUST: KUEHNEOLA DESMIUM (B. ET BR.) SYDOW [UREDO DESMIUM (BERK. ET BR.) PETCH]

Symptoms.—A common leaf rust found at the College of Agriculture on *Gossypium herbaceum* Linn. and on *Gossypium brasiliense* Macfad. Infected leaves are entirely covered on both surfaces with the minute brownish to black pustules. Little damage is done.

HEVEA BRASILIENSIS (HBK.) MUELL.-ARG. PARA RUBBER

BLACK ROT OF FRUITS: PHYTOPHTHORA FABERI MAUBLANG

Symptoms.—Diseased fruits are blackened, with a more or less watery discoloration, and rot upon the tree. The outer layer of the fruit shrivels, splits and dries up without maturing the seeds. Older diseased pods with matured seeds are shrivelled so that the seeds cannot be liberated. The disease is most severe during excessively damp periods and may cause the loss of the entire fruit crop. The fungus often grows from diseased fruits into the twigs causing a die-back. Usually the disease does not advance far down the twig. Diseased fruits serve as a source of infection for the stem canker.

Causal organism.—The causal organism is the same as discussed under *Hevea* and cacao canker and the black rot of cacao pods.

Control.—All diseased fruits should be collected and burned. Proper distances for planting and the sanitary precautions as discussed under the canker of Para rubber serve equally well in reducing the black rot of the fruits.

CANKER: PHYTOPHTHORA FABERI MAUBLANC

Symptoms.—The canker of Para rubber may be rather hard to detect in its early stages. In the Philippines the disease is similar to that discussed by Petch in Ceylon. External symptoms usually consist in a darkening of the bark, and in older cases there may be a definite demarcation of the diseased area. Most frequently the diseased area is smooth, but it may be cracked and scaly. During damp weather a reddish or purplish liquid sometimes exudes from the larger diseased areas. On older trees the disease cannot always be noticed from outward appearances, for a true cankered condition may not be produced. Internal symptoms are then the only indications of disease. Diseased trees cease to yield latex. The cortex, instead of its healthy white, yellowish, or clear red appearance, is characterized by a black layer produced under the outer brown bark and underneath this the cortex is discolored, in young cases gray, and in older cases a purplish red. In young cases only the outer layer of the bark may be diseased. This can be detected by carefully scraping the areas that do not produce latex to determine whether the cortex is blackish instead of being a healthy color.

When diseased trees have been cut down and piled ready for burning, they may be attacked by *Megalonectria pseudotrichia* (Schw.) Speg., which is characterized by a dense reddish mass of raised bodies, the perithecia, produced on the surface of the trees. This fungus is regarded as a saprophyte and is only found on the dead or weakened portions of trees. It may, however, gain entrance into diseased areas of living trees, consequently it should be guarded against.

Causal organism.—The Para rubber canker is produced by the same fungus that produces the black rot of *Hevea* fruits and also the black rot of pods and canker of cacao. The organism is more fully discussed under cacao. On rubber, so far as has been observed, only the conidial or sporangial stage is produced. Generally the asexual spore bodies are roundish or egg-shaped. Conidia germinate directly by the production of a germ tube that develops into the mycelium. These same spores under favorable damp or rainy conditions may germinate by the production of zoöspores. The spore body is then called a sporangium or a zoösporangium. The zoöspores swim about for a time, then come to rest and germinate as ordinary conidia by the production of a germ tube, which penetrates into the host primarily through injuries. The mycelium is almost always internal, spreading through the bark and is seldom found growing

over the surface. The fungus grows well in pure culture, producing on sterile potato cylinders, a dense white mycelium with conidia, sporangia, and chlamydo-spores.

Control.—All diseased portions should be carefully cut out, down to the healthy tissue, and burned. Disinfection of the knives used for cutting with a 2 per cent formalin solution is recommended. A careful inspection of the plantation should be kept up so that the cankers can be cut out when they first appear. All wounds made by cutting out the diseased cortex should be painted with a coal-tar preparation, care being taken not to paint the cambium layer at the edges of the cut surface. Cacao should never be planted with or near Hevea rubber. In severe cases of the disease it might be advisable to spray the trunks of young trees with Bordeaux mixture. This cannot be done with tapping trees. The humidity of the plantation should be lessened by admitting air and sunlight through the removal of intercrops, thinning out by pruning and planting according to the regulation distance, which will permit a ready aëration. All diseased trees and rubber trash should be burned as soon as possible to avoid the spread of *Phytophthora* spores. It might be advisable to obtain a large blast torch for this purpose.

LEAF SPOT: HELMINTHOSPORIUM HEVEAE PETCH

Symptoms.—Leaves of nursery plants a meter or more high may become spotted, but no serious damage has been observed. The spots may be thickly scattered over the leaf surface. When young they are minute, having purple centers with a lighter purple haze about the edges; older spots are circular, 3 to 5 millimeters in diameter, with white semitransparent centers bordered with a purplish ring. The disease has been observed on seedling plants only.

Causal organism.—The spores are produced on both surfaces of the leaf, but are more abundant on the lower surface. They are cymbiform, brown, and from eight to eleven septate. The conidiophores are scattered, simple, brownish, and septate.

Control.—Since the disease is not serious and never has been observed to cause defoliation, no control has been found necessary. If severe cases of infection should arise, spraying with Bordeaux mixture would control the disease.

PHYSIOLOGICAL TROUBLE

Symptoms.—This diseased condition is sometimes spoken of as brown bast. The external appearance of such trees is usually normal. Internal characters may be normal, but fre-

quently a gray to dark brown discoloration appears in the vicinity of the bast. The chief internal symptom is the stoppage of latex flow, due to some abnormal condition of the latex tubes.

Causal organism.—No causal organism has been associated with the disease. It appears to be due to some abnormal physiological condition, which may be inherent in certain trees; however, in certain cases trees appear to recover.

Control.—Tapping should be discontinued for a period of years on infected trees. Seeds for propagation should never be selected from diseased trees.

ROOT DISEASE: FOMES LIGNOSUS (KL.) BRESADOLA

Symptoms.—The disease is most severe upon young trees from 1 to 3 years old. Frequently diseased patches are produced in plantations. Diseased trees at first show a yellowing of the leaves, which is followed by a wilting and death. Dead trees can be easily pulled up or pushed over. The diseased roots are characteristically covered with a white mycelium, which may be in the form of strands spreading over the root or in the form of a sheet covering the entire surface. The white strands of mycelium spreading over the roots are the characteristic symptoms. These strands may be 0.5 to 1 centimeter broad and may be divided into finer strands that spread to the lower portion of the trunk and to the extremities of the roots. The diseased roots and lower trunk are not discolored, but become soft, like punk. The fungus also develops well on a number of jungle trees and stumps where it produces the same symptoms.

Causal organism.—The mycelium growing over the surface of the roots penetrates into the tissues, thereby causing death. The cortex and wood are completely invaded by the mycelium. From diseased roots the mycelium can spread through the ground to the roots of healthy trees. This is one of the chief methods of spread and accounts for the disease appearing in patches throughout the plantation. Fruiting bodies of the fungus are not usually produced on rubber trees, because the diseased trees are usually burned as soon as found. If diseased stumps are left standing, the characteristic fruiting bodies will be produced. They are more commonly found on stumps of jungle trees and are always produced above ground.

The fruiting bodies are at first orange yellow cushions, which later develop into flat, somewhat semicircular plates. They are usually 8 centimeters long, 4 centimeters wide, and 1 centimeter thick behind, but may attain a width of 30 centimeters. They are perennial and woody, belonging to the "bracket fungi." At first

the upper surface is red-brown with concentric dark brown lines. It is smooth with concentric grooves parallel to the outer edge. The lower surface is covered with minute pores, the spore-bearing surfaces, and at first is orange; but later, when old, is red-brown.

Control.—The disease as a rule cannot be detected until the tree is about to die; consequently remedial measures must be practiced that will prevent the fungus attack. Land cleared for rubber plantations should have the old jungle stumps removed and burned as completely as possible down to a depth of at least half a meter. Preferably the land should be cleared, cleaned, and planted to a cultivated crop two years before planting the rubber. This will give time for the complete removal and burning of all stumps.

Dead rubber trees must be dug up with all roots and burned. Since the disease frequently occurs in patches, these patches may be isolated by digging a trench, about 45 centimeters deep, around the affected trees. Quicklime should be scattered over the ground and in the trench. This will prevent the fungus from spreading through the ground to healthy surrounding trees. All dead stumps should be removed and the infected spot dug up so as to destroy as many of the roots as possible. Frequently newly infected trees near affected spots can be saved by removing all dirt from the tap roots and cutting out the affected portions. If the roots are too severely diseased, the tree must be dug up and burned. It is absolutely necessary to remove all dead stumps so as to prevent the spread of the disease by the mycelium growing through the ground, and to prevent the production of fruiting bodies, which produce spores that spread the disease. An efficient drainage system should be provided for poorly drained regions.

SPOTTING OF PREPARED PLANTATION RUBBER: SAPROPHYTIC FUNGI

Symptoms.—Prepared plantation rubber when produced under improper conditions may, during drying, become spotted with bright red, pink, reddish yellow, dark blue, bluish green, bright yellow, black, or clear spots. The colors can be more easily observed by holding the sheets of rubber up to the light. These spots may extend through the entire sheet, or they may be confined to the upper or the lower surface. They range from mere specks, 1 to 2 millimeters in diameter, to blotches, 15 centimeters in width. When the spots are abundant, a mottling of red or yellow may be produced. The color usually fades slightly after several weeks, but it has been observed to last for an indefinite period.

Causal organism.—The organisms causing the trouble in the Philippines have not been studied. In the Federated Malay States the following common saprophytic fungi have been assigned as the cause: *Penicillium maculans* sp. n., *Fusarium*, *Chromosporium crustaceum* sp. n., *Trichoderma koningi* (Oud.) Oudemans et Koning, *Eurotium candidum* Speg., and *Bacillus prodigiosus* (Ehrenb.) Fluegge. Oil and dirt are other sources of discoloration. The latex becomes primarily infected in the field due to improper field cultural methods, the use of contaminated water for washing out jars, and to contaminated pails.

Control.—Ordinary sanitary measures are sufficient for control. General cleanliness in tapping, collecting of latex, and preparation of rubber should be observed. The plantation should be kept free from all dead decaying matter which harbors saprophytes. The pails used for the collection of latex should be thoroughly scalded after using each day. Water used in cleaning the cups should be obtained from a source free from contamination. Collectors should never be allowed to obtain water for washing from contaminated streams. The factory and drying shed should be constructed according to the best accepted methods. The drying sheds should be located in a well-aërated place so as to provide for plenty of circulation, for rapid drying lessens the chances of spotting. Thin crêpe is less apt to become spotted, due to its quicker drying. Spotted rubber should never be packed with clean rubber. Usually these precautions are sufficient to prevent the trouble. In severe cases of infection it is advisable to sterilize the latex with 1 part of formalin to 400 parts of latex. Lightly spotted rubber may be somewhat cleared by rerolling the dried rubber and washing thoroughly with water.

OTHER FUNGI

A large number of apparently saprophytic organisms appear on the dead branches of Para rubber. Among these *Tryblidiella mindanaensis* Henn. and *Eutypella heveae* Yates have been identified.

HIBISCUS SABDARIFFA LINN. ROSELLE

BLIGHT: PHOMA SABDARIFFAE SACCARDO

Symptoms.—A stem blight that is rather severe on roselle, often killing entire plants. Diseased stems are attacked chiefly at the bases of small branches, at the nodes. Internodes also may be attacked. The spots spread until they entirely encircle the twigs. They are black with gray centers and are specked with minute black bodies. The disease is most severe on nearly matured plants.

Causal organism.—The minute black bodies are pycnidia. Upon crushing the pycnidia, a mass of small, one-celled, somewhat elongated, slightly olivaceous spores is expelled. The fungus grows well in pure culture, producing at first a growth of white mycelium, which later becomes studded with black pycnidia.

Control.—All diseased stems should be collected and burned. Crop rotation should be practiced.

IPOMOEA BATATAS POIR. SWEET POTATO

STORAGE ROT: LASIODIPLODIA THEOBROMAE (PAT.) GRIFFON ET MAUBLANC

Symptoms.—A common dry-storage rot, which is characterized by the production of a sooty mass of spores on the outside of infected potatoes. This disease is the same as that found upon the cacao fruit and other root crops and fruits (Plate XIX, fig. 5).

Causal organism.—The organism causing the disease is identical with that described under cacao. Cross inoculations from the fungus on cacao fruit to the sweet potato or vice versa can be easily carried out. The mycelium penetrates throughout the root and accumulates under the surface to produce a series of pycnidia, from which the mass of black spores arises (fig. 20). The organism is more fully discussed under cacao.

Control.—Care should be used in digging the potatoes, so as to avoid injuries. The surface of the potatoes should be allowed to dry before storage. Storage should be in a well-ventilated place. All infected potatoes should be taken out and burned. Cacao fruits and root crops diseased with *Lasiodiplodia* must be kept away from stored sweet potatoes.

STORAGE ROT: RHIZOPUS

Symptoms.—A soft rot is frequently produced by this fungus. Diseased roots are soft and are covered with a black felty mold.

Causal organism.—This felty mass is made up of large num-

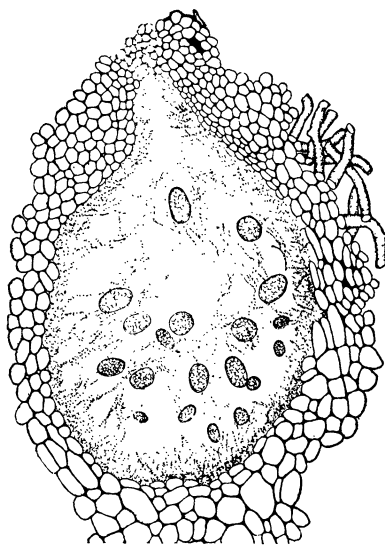

FIG. 20. *Lasiodiplodia theobromae* (Pat.) Griff. et Maubl. Section through diseased sweet potato, showing pycnidium, ostium, paraphyses, and immature spores ($\times 270$).

bers of sporangiophores and sporangia. The sporangia contain numerous black spores.

Control.—Sweet potatoes should be stored in a dry, well-aërated place. All rotted potatoes should be destroyed.

LACTUCA SATIVA LINN. LETTUCE

TIPBURN

Symptoms.—A nonparasitic disease that is common during the dry season. Leaves turn brown at the tip and gradually shrivel up.

(To be concluded.)

7000
P 5/10
J 8

U.S. DEPARTMENT OF AGRICULTURE
BUREAU OF SCIENCE

VOL. XIII, SEC. A, No. 5

SEPTEMBER, 1918

THE PHILIPPINE JOURNAL OF SCIENCE

ALVIN J. COX, M. A., Ph. D.
GENERAL EDITOR

SECTION A CHEMICAL AND GEOLOGICAL SCIENCES AND THE INDUSTRIES

EDITED WITH THE COÖPERATION OF

H. C. BRILL, Ph. D.; J. R. WRIGHT, Ph. D.; G. W. HEISE, M. S.
T. DAR JUAN, A. B., Ph. D.; A. H. WELLS, A. B.
R. C. MCGREGOR, A. B.; H. E. KUPFER, A. B.

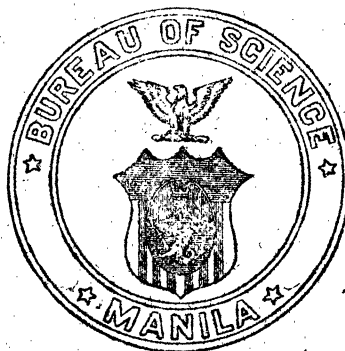

MANILA
BUREAU OF PRINTING
1918

PHILIPPINE JOURNAL OF SCIENCE

A TEN-YEAR INDEX

CONTENTS AND INDEX OF THE PHILIPPINE JOURNAL OF SCIENCE, VOLUME I (1906) TO VOLUME X (1915)

Order No. 449. Bureau of Science Publication No. 8. Paper, 441 pages.
Price \$2, United States currency, postpaid.

One copy of this index has been sent free of charge to each subscriber that has received Volumes XI and XII of the Journal.

This publication consists of:

The complete contents of the first ten volumes of the Philippine Journal of Science, all sections; giving all authors, titles of articles, and page numbers. The exact date of issue of each number is recorded.

An author index, being an alphabetical list of all the contributors. The titles of all the articles are listed under the names of their respective authors.

A subject index. The subject matter is very fully indexed by catch words from the titles, by geographical localities, and by subjects. All systematic names in zoölogy and botany, as well as the thousands of English and local names, are entered in the index.

STUDIES IN PHILIPPINE DIPTERA, II

By M. BEZZI

Order No. 437. Bureau of Science Publication No. 10. Paper, 59 pages and 1 plate.
Price \$0.50, United States currency, postpaid.

This is the second century of Professor Bezzi's enumeration of Philippine species of flies and includes descriptions of new genera and new species.

PLEASE GIVE ORDER NUMBER

Orders for Bureau of Science publications may be sent to the BUSINESS MANAGER, Philippine Journal of Science, Bureau of Science, Manila, P. I., or to any of the following agents:

AGENTS

THE MACMILLAN COMPANY, 64-66 Fifth Avenue, New York, U. S. A.
WM. WESLEY & SON, 28 Essex Street, Strand, London, W. C., England.
MARTINUS NIJHOFF, Lange Voorhout 9, The Hague, Holland.
KELLY & WALSH, Limited, 32 Raffles Place, Singapore, Straits Settlements.
A. M. & J. FERGUSON, 19 Baillie Street, Colombo, Ceylon.
THACKER, SPINK & Co., P. O. Box 54, Calcutta, India.

THE PHILIPPINE JOURNAL OF SCIENCE

A. CHEMICAL AND GEOLOGICAL SCIENCES
AND THE INDUSTRIES

VOL. XIII

SEPTEMBER, 1918

No. 5

PHILIPPINE ECONOMIC-PLANT DISEASES

By OTTO A. REINKING

(From the College of Agriculture, Los Baños)

(Concluded.)

LYCOPERSICUM ESCULENTUM MILL. TOMATO

BACTERIAL WILT: *BACILLUS SOLANACEARUM* ERW. SMITH

This bacterial wilt may be the limiting factor in the production of tomatoes. It is impossible to grow tomatoes in soil that is thoroughly infected with the organism.

Symptoms.—The first evidence of disease is a wilting of the plant. Later the plant shrivels; it turns yellowish and then brown to black. A discoloration of the vascular bundles is observed in cross section.

Causal organism.—Microscopic examination shows the xylem tubes of vascular bundles to be entirely clogged with bacteria, thus stopping the flow of water and causing the wilt (fig. 21). In advanced stages the organism may invade the parenchyma.

Control.—It is practically impossible to control the disease in heavily infected soil. Care should be taken to keep the disease-producing organism out of noninfected soil by planting only healthy plants produced

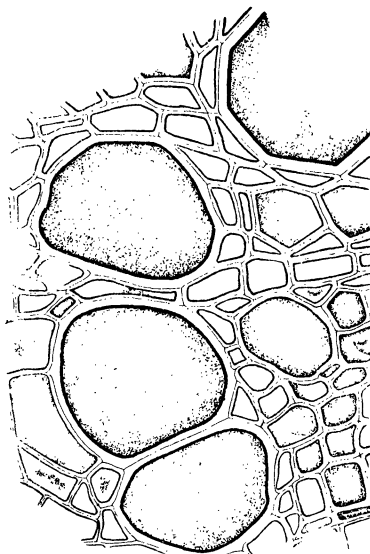

FIG. 21. *Bacillus solanacearum* Erw. Smith. Cross section of tomato stem, showing xylem tubes completely filled with bacteria ($\times 350$).

from seeds of healthy plants. Seedlings should be grown in sterilized soil. Injuring of plants should be avoided during transplanting. All diseased plants should be pulled up and burned. When once the soil becomes infected, a 5-year crop rotation in which no solanaceous plants are grown will have to be practiced. Insects attacking tomatoes undoubtedly are factors in the spread of the disease, so the control of these would be beneficial. The production of disease-enduring varieties would possibly be a means of avoiding the disease.

DAMPING OFF: RHIZOCTONIA AND PYTHIUM DEBARYANUM HESSE

Symptoms.—Damping off of seedlings is common with plants grown in unsterilized soil. This is true of all vegetable seedlings. Plants are attacked just at the surface of the ground. The stem at first is browned, later it shrivels, and then it becomes black. Diseased plants fall over.

Causal organism.—A *Rhizoctonia* and a fungus similar to *Pythium debaryanum* Hesse are associated with the disease, invading the stem and causing shrinking and death.

Control.—Seedlings should be grown in sterilized soil.

POWDERY MILDEW: ERSYPHACEAE

Symptoms.—Plants are frequently, during the cold drier season in December, January, and February, entirely covered with a white powdery mildew. The disease may be very severe, causing first the browning and death of the lower, older leaves and finally the death of the plant. The production of fruit is inhibited.

Causal organism.—The powdery mass is made up of typical conidia and conidiophores of species belonging to the family Erysiphaceae. The mycelium is superficial and only penetrates into the plant by means of haustoria. In no case has the ascigerous stage been observed. This is true with all powdery mildews studied on economic plants, and it seems to be a general observation throughout the tropics that only the conidial stage is usually produced.

Control.—Dusting with sulphur or spraying with any standard fungicide will control the disease.

MANGIFERA INDICA LINN. MANGO

LEAF SPOT: CERCOSPORA MANGIFERAE KOORDERS

Symptoms.—This is a common leaf spot, characteristic of the *Cercospora* type. It is often abundant and does some damage.

LEAF SPOT: LEPTOTHYRIUM CIRCUMSCISSUM SYDOW

Symptoms.—A leaf spot that is not abundant, but may destroy leaves by attacking the whole leaf surface.

LEAF SPOT: PHYLLACHORA

Symptoms.—Shiny black stromatic masses may be produced on leaves. Little damage is done.

Other leaf fungi are *Meliola mangiferae* Earle, which produces a superficial growth on the leaves; and *Pestalozzia funera* Desm. and *P. pauciseta* Sacc., which are found on weakened leaves.

Endoxyla mangiferae Henn. has been found on dead limbs.

MANIHOT DICHOTOMA ULE. CEARA RUBBER

LEAF SPOT: PHYLLOSTICTA MANIHOTICOLA SYDOW

Symptoms.—A common and sometimes severe leaf spot found upon the leaves of *Ceara* rubber trees. Minute black specks are produced in the center of the gray spots.

MANIHOT UTILISSIMA POHL. CASSAVA, CAMOTING CAHOY

LEAF SPOT: CERCOSPORA MANIHOTIS P. HENNINGS

Symptoms.—Leaf spotting of the cassava is present, but not abundant enough to cause any great damage. Diseased spots are irregularly circular and brown. *Cercospora henningsii* Allesch. also appears in Philippine literature as occurring on cassava.

Other fungi found on dead and dying branches are *Diplodia manihoti* Sacc., *Guignardia manihoti* Sacc., *Guignardia manihoti* Sacc. var. *diminuta* Sacc., *Colletotrichum lussoniense* Sacc., and *Steirochaete lussoniensis* Sacc. *Phoma herbarum* Westd. is found on dead leaves.

MORUS ALBA LINN. MULBERRY

POWDERY MILDEW: PHYLLACTINIA SUFFULTA (REBENT.) SACCARDO

Symptoms.—A more or less common disease, producing a white powder on the under surface of leaves. Little damage is done.

RUST: KUEHNEOLA FIGI (CAST.) BUTLER VAR. MORICOLA P. HENNINGS

Symptoms.—This rather common fungus of many of the Moraceae produces the characteristic, raised brownish sori and rusty powder of spores on the under surface of leaves, as described for the rust of fig (Plate XIV, fig. 3).

TWIG FUNGI

Dead and dying twigs yield a variety of fungi, among them being the following: *Traversoa dothiorelloides* Sacc. et Syd.,

Botryodiplodia anceps Sacc. et Syd., *Valsaria insitiva* (de Not.) Ces. et de Not., *Diplodia mori* West.

MUCUNA DEERINGIANA MERR. (STIZOLOBIUM DEERINGIANA BORT.)
VELVET BEAN

The velvet bean may have its leaves attacked by *Cercospora stizolobii* Syd. and by a rust, *Uromyces mucunae* Rabh.

MUSA SAPIENTUM LINN. BANANA

BACTERIAL STEM ROT

Symptoms.—A stem rot occurs on weakened bananas. The disease is not very serious and probably is due to bacteria. None of the true bud rots have been yet observed in a destructive form on banana.

FRUIT BLAST

Symptoms.—A blasting of the young fruit occurs frequently, but is undoubtedly due to causes other than fungi. A fungus, *Diplodia crebra* Sacc., has been found associated with the diseased fruits.

LEAF SPOT: MACROPHOMA MUSAE (CKE.) BERLESE ET VOGLINO

Symptoms.—Older leaves with lowered vitality are frequently severely attacked by this fungus. Leaves whipped by wind are more subject to attack. The disease is characterized by the formation of blackish to brownish stripes extending from the midrib to the edges. The surface of diseased leaves is roughened, due to the numerous thickly produced black spore-bearing bodies of the fungus. These pycnidia are rather large and are produced in enormous numbers. They are frequently compacted, forming circular, raised blackish spots. Since only the older leaves, with lowered vitality, are attacked, the disease is not a serious one.

Causal organism.—Within the pycnidia are produced large, oval, hyaline, one-celled spores containing numerous oil droplets.

Control.—Burning of infected fallen leaves is advised.

Another fungus, *Sporodesmium bakeri* Syd., may be found associated with the *Macrophoma* leaf spot. It is, however, of little importance. *Plicaria bananincola* Rehm. is found on dead plants.

LEAF SPOT: MYCOSPHAERELLA MUSAE SPEGAZZINI

Symptoms.—A common leaf spot found in almost all plantations. The disease is not destructive and consequently is of little importance. It is characterized by the formation of rather

definite spots, usually somewhat elongated, from 5 millimeters to 2.5 centimeters in length (Plate XI, fig. 2). Spots may have a grayish center surrounded by a black ring, or they may be entirely blackened with a darker border. In the center of the grayish portion are minute black specks, the perithecia. Spots may coalesce and, if the leaf be badly infected, a general browning may occur.

Causal organism.—The perithecia are produced under the epidermis, are brown with definite wall markings, and have ostiola. Within are produced the asci, containing typically eight, hyaline, two-celled spores similar to those produced by *Mycosphaerella* on papaya.

Control.—All fallen leaves should be collected and burned.

MUSA TEXTILIS NÉE. ABACÁ

BACTERIAL HEART ROT

Symptoms.—The disease is characterized by the rotting of the central group of rolled young leaves. Rot starts usually at the tip and advances downward until the entire young central portion of the plant is attacked. The diseased portion is at first yellowed, then turns black, and rots. A slight odor may accompany the rot. Frequently the central group of diseased leaves near the tip is pushed upward in a folded mass. In early stages the disease is confined to the young central heart and does not penetrate into the surrounding older sheaths. In advanced stages the entire central portion becomes diseased and the plant dies (Plate XI, fig. 7). The disease is most severe in thick plantings where there is a high humidity and a lack of aëration. It may also be severe in excessively damp locations. From these seats of infection the disease may spread to surrounding plants. A large amount of destruction is done in infected areas.

Causal organism.—Microscopic examination shows only the presence of bacteria. They advance through the plant tissue by mass action (fig. 22). Isolations from diseased stems have produced pure cultures of bacteria. The bacteria, when inoculated into healthy plants, produce the typical disease. The study

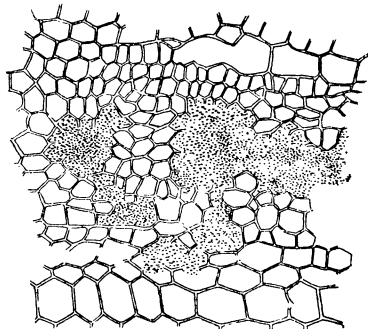

FIG. 22. Section through diseased abacá leaf, in heart of plant, showing mass of bacteria in tissue ($\times 330$).

of the causal organism is still in progress, but has not advanced to a stage where a definite name can be given.

Control.—Abacá should be planted 3 meters apart each way. Plantings in excessively damp, poorly aerated pockets should be avoided. All diseased plants should be cut and destroyed by burning. Care should be taken that the cuts are made well below the advanced portion of the disease. Knives used for cutting should be sterilized after each cut by wiping off with a solution of corrosive sublimate, 1 to 1,000.

LEAF SPOT: MACROPHOMA MUSAE (CKE.) BERL. ET VOGLINO

Symptoms.—This fungus causes a spotting of the leaf similar to that discussed under banana.

LEAF SPOT: MYCOSPHAERELLA MUSAE SPEGAZZINI

Symptoms.—Another leaf spot is found on abacá, being similar to that produced by *Mycosphaerella musae* Speg. on the banana. Spots may be definite and circular, or they may be irregular. The center of each spot is grayish and is bordered by a dark ring. The disease is not serious and causes little damage.

NICOTIANA TABACUM LINN. TOBACCO

BACTERIAL BLIGHT

Symptoms.—A bacterial leaf spot has been observed during the rainy season. Lower leaves are severely attacked. The disease has been evident only during exceptionally moist weather. Spots are irregularly circular, from 5 millimeters to 3 centimeters in diameter, have brownish gray centers, with watery parchmentlike borders, 3 to 6 millimeters wide. Concentric rings of light and darker brown may be produced in the spots. Smaller spots seem to be limited by the larger veins. Larger spots run together, often covering the entire leaf. In the latter case the leaf is shrunken, somewhat curled, dried up like parchment, and opaque.

Causal organism.—Isolation experiments indicate that this disease is due to bacteria. Cultural and inoculation studies have not progressed sufficiently to permit the assigning of a name.

Control.—Plants should not be set too thickly, thus allowing for plenty of air.

BACTERIAL WILT: BACILLUS SOLANACEARUM ERW. SMITH

Symptoms.—Tobacco may be badly infected with this common bacterial wilt of solanaceous plants (Plate XII, fig. 1). Plants

15 centimeters to 1 meter in height are visibly affected. Wilting is the first indication of disease; later a brown stripe is produced, usually from the petioles and extending down the stem. A slight shrinkage in the brown-striped portion may take place. Diseased plants die (Plate XII, fig. 2).

No serious epidemics in tobacco plantations have been reported; however, they may occur at any time, unless the organism be kept in check.

Causal organism.—The organism is the same as that causing wilts of all solanaceous plants. The bacteria gain entrance into the plant chiefly through mechanical and insect injuries. Nematode root galls are frequently found on wilted plants. The bacteria clog up the xylem tubes, stopping the flow of water and causing the wilt. In later stages of infection the parenchyma may be invaded.

Control.—It is practically impossible to control the disease in heavily infected soil. The organism should be kept out of new soil by planting only healthy plants produced from seeds of healthy plants. Soil should be sterilized when used for seedlings grown in flats. During transplanting care should be taken to avoid injury of the roots of young plants. Insect enemies and nematodes should be held in check. All diseased plants should be burned. If the soil be heavily infected with bacteria, a five-year system of crop rotation, in which no tomatoes, potatoes, eggplants, pepper, or other solanaceous plants are grown, should be practiced. The production of disease-resisting or enduring plants would hold the disease in check.

CHLOROSIS

Symptoms.—A chlorotic condition or yellowing of plants is frequently found, but this is not considered a serious affection.

CURING AND FERMENTING TROUBLES: LEAF SPOTTING

Symptoms.—During fermenting of the leaves, leaf spotting frequently takes place. The spots are greenish and circular, from 3 to 15 millimeters in diameter. Infected leaves cannot be used as wrapper.

Causal organism.—Isolation experiments indicate that this disease is due to a fungus. As yet no spores have been observed. Mycelium is produced in abundance in the spots. The fungus grows well in pure culture, producing a thick dark gray growth.

Control.—Infected leaves should be sorted out, so as to keep the disease from spreading.

DAMPING OFF OF SEEDLINGS: RHIZOCTONIA, PYTHIUM DEBARYANUM HESSE,
PHYTOPHTHORA NICOTIANÆ BREDÆ DE HAAN

Symptoms.—Tobacco seedlings are extremely susceptible to damping off. All the plants in a given flat may be damped off. The young tender plants are attacked just at the surface of the ground. The stem shrinks and becomes rather watery, and the seedlings fall over (Plate XIII, figs. 2 and 3).

Causal organism.—A study of the fungi causing this condition revealed the presence of a *Rhizoctonia*, usually associated with *Pythium debaryanum* Hesse. *Phytophthora nicotianae* Breda de Haan has been also proved to cause damping off of tobacco (fig. 23).

Control.—All soil used for the growth of seedlings should be thoroughly sterilized by heating. The seedlings should be grown in well-aërated places, free from excessive moisture, and should be placed in the sun from time to time.

Damping off is very general and severe with flower and vegetable seedlings. In the majority of cases a *Rhizoctonia* was found, and the latter was usually associated with a fungus similar to *Pythium debaryanum* Hesse. A *Sclerotium* was also found to cause a damping off or stem rot of coffee seedlings

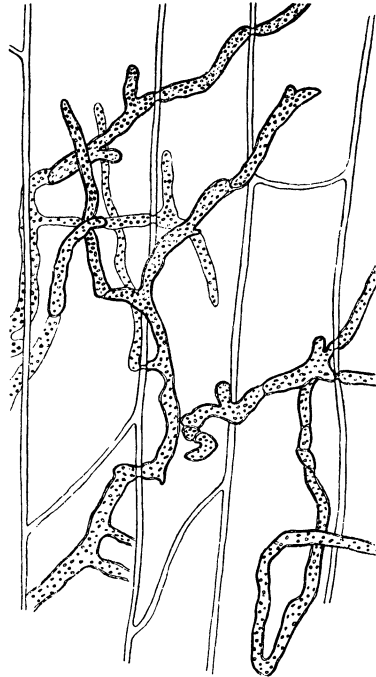

FIG. 23. *Phytophthora nicotianae* Breda de Haan. Section of damped-off stem of tobacco, showing mycelium penetrating throughout the tissue ($\times 310$).

and other plants. *Phytophthora nicotianae* Breda de Haan and a *Fusarium* also have been determined to cause damping off. These troubles can be easily avoided by soil sterilization.

LEAF SPOT: CERCOSPORA NICOTIANÆ ELLIS ET EVERHART

Symptoms.—The common "frog eye" of tobacco is found generally in tobacco-growing regions. Serious and extensive damage may be done to the lower leaves, especially where the plants are crowded. The disease is characterized by the production of irregularly circular spots, which are from 1 to 5

millimeters in diameter. The center of each spot is ashen gray and is bordered with a brown ring (Plate XII, fig. 3). In the ashen gray portion of older spots is a blackish dust.

Causal organism.—The blackish dust is made up of conidiophores and conidia. The conidiophores are produced in groups from stomata and are light brown and septate. They may germinate under suitable conditions, producing hyaline germ tubes that infect the plant. The conidia are typical *Cercospora* conidia. They are hyaline, much elongated, thick at one end, tapering to the other. Spores frequently contain as many as fifteen cells (fig. 24). Germination usually takes place by the production of from two to four germ tubes from the same number of cells.

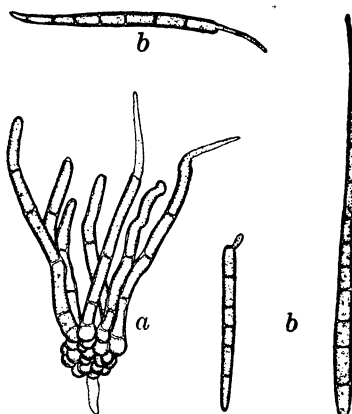

FIG. 24. *Cercospora nicotianae* Ell. et Ev.
a, group of conidiophores, two of which are germinating ($\times 340$); b, germinating conidia ($\times 340$).

Control.—Badly diseased lower leaves should be collected and burned or used for a low-grade tobacco. Diseased leaves should not be left in the soil. Open planting should be practiced where possible. Crop rotation is effective in checking the disease.

ROOT GALLS: NEMATODES, HETERODERA RADICICOLA GREEF ET MÜLLER

Symptoms.—Root galls are frequently produced by nematodes; however, no serious damage has been reported. The galls may be formed on the smaller or larger roots and sometimes they are produced in abundance. Plants severely attacked are stunted or may be killed (Plate XII, fig. 4). The nematodes seem to make way for the entrance of the bacteria, causing the tobacco wilt.

Control.—Rotation of crops will help to keep the organism at a minimum.

ORYZA SATIVA LINN. RICE

BACTERIAL LEAF STRIPE

Symptoms.—A striping of the leaves of certain varieties of upland rice may be serious. In the young stages the stripes are from 0.5 to 1 millimeter wide and from 3 to 5 millimeters long, run lengthwise, and have a watery, dark green, translucent appearance. In this stage the disease is usually confined

to the portion between the larger veins. These spots enlarge lengthwise and may advance over the larger veins producing more or less of a blotch. Older diseased portions may be 4 millimeters wide and from 2 to 20 centimeters long. These stripes still have a watery appearance, but change to a light brown. Amber-colored droplets of bacteria ooze from these diseased portions. As the leaf dries out these droplets of bacteria harden producing small roundish amber-colored beads. The disease appears to be most prevalent on succulent plants.

Causal organism.—Microscopic examination and cultures indicate that the disease is due to bacteria. Under the microscope, bacteria can be observed to stream from the vascular bundles. A detailed study is now in progress.

Control.—No control can be given until the disease has been carefully studied.

FALSE SMUT OR LUMP SMUT: *USTILAGINOIDEA VIRENS* (CKE.) TAKAHASHI

Symptoms.—This conspicuous disease is found in practically all rice-growing sections. Only a few grains in each panicle are attacked. Diseased grains are characterized by the production of large masses of sclerotia. Infected grains are enlarged, oval to spherical, from 2 to 6 millimeters in shortest diameter. The enlargement is due to the production of a sclerotial mass, which in its early stages has a bright yellow covering, but later is coated with a dark green powder (Plate VIII, fig. 2).

During damp weather the disease may be severe and seems to be more prevalent on certain varieties of rice.

Causal organism.—This dark green powder is composed of spores. No perithecia or ascospores have been observed in the sclerotial mass. The spores are small and brown and covered with short stout spines or echinulations. Germination takes place by the production of a germ tube with an enlarged knoblike end (fig. 25).

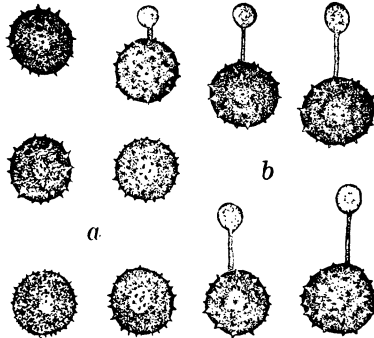

FIG. 25. *Ustilagoideia virens* (Cke.) Tak.
a, spores ($\times 1,800$); b, germinating spores ($\times 1,800$).

Control.—The disease may become epidemic, due to the accumulation of sclerotial bodies that are allowed to fall upon the ground. All diseased heads should be collected and burned. Crop rotation should be practiced.

GLUME SPOT: PHYLLOSTICTA GLUMARUM SACCARDO

Symptoms.—Dead and weakened plants are subject to the attacks of numerous fungi. Minute black specks on the glumes are the pycnidia of this fungus. The fungus apparently attacks the plant as a saprophyte and causes little damage.

Other fungi found on dead glumes are *Leptosphaeria* (*Leptosphaerella*) *oryzina* Sacc., *Calonectria perpusilla* Sacc., *Haplographium chlorocephalum* (Fres.) Grove, *Clasterosporium punctiforme* Sacc., *Myrothecium oryzae* Sacc., *Helminthosporium*, and *Septoria miyakei* Sacc. What relation, if any, these fungi have to disease production has not been determined.

LEAF SPOT: CERCOSPORA

Symptoms.—Elongated brownish spots are frequently produced on the leaves (Plate VIII, fig. 5). These spots, when older, have ashen-gray centers and yield *Cercospora* spores. Little injury is caused.

LEAF SPOT: PHYLLOSTICTA MIURAI MIYAKE

Symptoms.—Dead and weakened leaves are frequently spotted with the minute black pycnidia of this fungus. The fungus appears to be saprophytic and consequently does little damage.

STEM ROT: RHIZOCTONIA

Symptoms.—The common soil *Rhizoctonia* may attack the base and outer older leaf sheaths of upland rice plants. Under certain conditions, such as in thickly planted fields during damp hot weather, severe injury may be produced. Severely attacked plants may have the entire outer group of leaves killed. The fungus mycelium can be seen on the dead leaves, which are frequently cemeted together by the mycelial strands. Plants attacked in this manner are stunted and bunchy due to the abnormal production of stools. Heads produced by such plants are frequently sterile. In less severe attacks spots are produced on the outer older leaf sheaths. These spots are from 1 to 2 centimeters long by 1 centimeter wide. Often they run together producing large blotches. Spots have straw-colored centers with wide borders of dark brown.

Causal organism.—The organism producing this disease is similar to that described under blight of soy beans and that causing stem rots and damping off. No spores have been observed. The mycelium spreads over and through the leaves and in advanced stages produces brown sclerotial bodies on diseased parts.

Control.—Fields should not be planted too thickly, so as to allow for plenty of aëration.

STEM ROT: SCLEROTIUM

Symptoms.—Rice seedlings under certain conditions in the seed beds may be attacked by a *Sclerotium*. When there is a lack of water in seed beds, the disease appears to be at its worst. The attack takes place near the ground on leaf sheath and stem. Affected seedlings at first are yellowed and stunted, later they turn brown and die. On the lower portions of attacked plants usually a coarse dirty white mycelium is produced with roundish, brown, smooth sclerotial bodies. The stems of older plants may be attacked, resulting in the production of sterile heads.

Causal organism.—The organism causing this trouble is a common *Sclerotium* discussed before as producing stem rots and damping off of various seedlings. It attacks the lower portions of the plants just above the ground. The fungus is more severe during damp weather and in seed beds that are only partially flooded. It is also found within the stems of older plants.

Control.—Seed beds should be kept flooded. If the disease is severe, all soil used for the growth of seedlings should be sterilized. Fields should not be planted too thickly.

STRAIGHT, OR STERILE, HEAD

Symptoms.—Certain varieties of rice are severely attacked by a disease of the panicle. From a half to the entire head may be affected. The kernels shrivel, and from a distance the heads can be seen to stand straight. The cause of this sterile condition, of from 50 to 100 per cent of the grains, has not been determined. It appears to be due to a lack of vigor in the plants. The lemma and palet of infected grains are discolored.

Causal organism.—Bacteria and fungi are associated with diseased grains. *Oospora orysetorum* Sacc. is frequently found on diseased heads. Stem borers are usually associated with diseased plants. *Rhizoctonia* and *Sclerotium* attacking the base of stems often cause straight or sterile head. Certain varieties appear to be immune.

Control.—No definite control can be given.

Other fungi found on rice are *Entyloma oryzae* Syd., on weakened leaves; and on rotting straw are found the following: *Ophiobolus oryzinus* Sacc., *Spegazzinia ornata* Sacc., *Sordaria oryseti* Sacc., and *Coniosporium oryzinum* Sacc.

PACHYRRHIZUS EROSUS (LINN.) URB. (PACHYRRHIZUS ANGULATUS RICH.). SINCAMAS

RUST: PHAKOSPORA PACHYRHIZI SYDOW

Symptoms.—The under surface of the leaves is covered with small, raised brown rust sori. Frequently a brownish white dust of spores is produced over the leaf surface. The disease may be severe, causing defoliation.

PHASEOLUS SPP. BEANS

BACTERIA BLIGHT: PSEUDOMONAS PHASEOLI ERW. SMITH

Symptoms.—This well-known disease is common and destructive on *Phaseolus vulgaris* Linn. and on *Phaseolus lunatus* Linn. Leaves, stems, and pods are attacked. Characteristic, irregular brownish spots with water-soaked edges are produced on the leaves. These spots may spread rapidly, killing the entire leaf. During dry weather spots become papery and brittle. The organism attacks pods, forming a characteristic watery spot, and also works down into the seed, thus infecting the latter. Entire fields of beans, especially those not acclimated, may be destroyed (Plate XIV, fig. 2).

Causal organism.—The bacteria causing this disease gain entrance primarily through injuries. They are found in great abundance in the leaf veins, from which they can be seen to exude in large numbers when the leaf is sectioned and examined under the microscope.

Control.—The disease is spread by the use of diseased seed. Since it is difficult to detect all cases of seed infection, only seed collected from healthy pods should be planted. Crop rotation should be practiced in severe cases of infection.

BLIGHT: RHIZOCTONIA

Symptoms.—Beans may be severely affected with a blight discussed under soy beans. *Phaseolus calcaratus* Roxb. and *Dolichos uniflorus* Lam. are especially susceptible when planted too thickly and allowed to spread over the ground. Thin planting and training vines to poles, when possible, will reduce the disease attacks.

BLIGHT: SCLEROTIUM

Symptoms.—A dense white growth of mycelium may be produced on the stems of plants. As the mycelium spreads to the leaves, the latter are killed, after showing the same characteristic symptoms as discussed under the *Rhizoctonia* blight.

Round, smooth brown sclerotial bodies may be produced on dead plants.

Causal organism.—The causal organism is a common soil fungus attacking a large number of plants and has been discussed under citrus and coffee.

Control.—The disease is not generally severe. Crop rotation should be practiced. In infected fields, planting should be timed so as to avoid the excessive rainy season.

LEAF SPOT: *CERCOSPORA LUSSONIENSIS* SACCARDO

Symptoms.—This common spot is widely distributed on field, garden, and Lima beans. Spots are irregularly roundish, usually

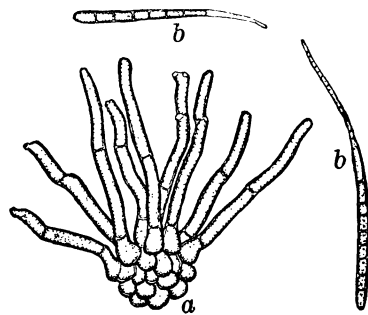

FIG. 26. *Cercospora lussoniensis* Sacc. from *Phaseolus lunatus* Linn. a, group of conidiophores ($\times 340$); b, germinating conidia ($\times 340$).

3 millimeters to 1.5 centimeters in diameter. The smaller spots are reddish brown; larger spots have ashen gray centers bordered with reddish brown rings. Spots may run together, thereby covering large portions of the leaf surface.

Causal organism.—Spores and conidiophores are of the characteristic *Cercospora* type. The conidia are elongated and hyaline; conidiophores are in groups and brownish (fig. 26).

Control.—The disease is moderately destructive, but not enough so to warrant any definite control except general sanitation and crop rotation.

LEAF SPOT: *PHYLLACHORA PHASEOLINA* SYDOW

Symptoms.—*Phaseolus calcaratus* Roxb. is frequently attacked by this fungus. The disease is characterized by the production of black spots scattered over the leaf surface. Spots are black, bordered with a straw-colored ring, roundish, sometimes elongated, raised, extending through the leaf to both surfaces, and made up of hard, shiny, stromatic masses of fungus mycelium.

Causal organism.—The stromata are roundish bodies extending through the leaf. Within the stromata are the perithecia, in which are produced the asci and ascospores. Each stromatic mass usually has one, or sometimes two, perithecia.

Control.—The disease is not serious on cultivated varieties. Crop rotation should be practiced to prevent epidemics.

POWDERY MILDEW: ERYSIIPHACEAE

Symptoms.—A powdery mildew may be produced on the surface of leaves of *Phaseolus mungo* Linn. Little damage is done.

Causal organism.—Conidia and conidiophores of the Erysiphaceae type are produced. No perfect stage has been observed.

Control.—Rotation of crops.

RUST: UROMYCES APPENDICULATUS (PERS.) LINK

Symptoms.—This rust is commonly found on *Phaseolus mungo* Linn. Minute, slightly powdery, raised brownish pustules are produced on the lower surface of the leaves. The disease is not often serious, but may cause the loss of a considerable amount of foliage.

Causal organism.—Brown uredospores and black teleutospores are produced in the sori.

Control.—Crop rotation should be practiced.

SOOTY MOLD

Symptoms.—Frequently *Phaseolus calcaratus* Roxb. as well as other beans may be covered with a black mold. The fungus is superficial and does little damage. It grows on the exudate of aphids.

Causal organism.—The organism has not been identified.

Control.—No special control need be practiced, since the disease is not serious.

Other fungi of more or less importance have been observed on beans. On the ripened pods of *Phaseolus vulgaris* Linn. are found *Diplodia phaseolina* Sacc. and *Asteroma phaseoli* Brun. *Phaseolus lunatus* Linn. may be attacked just at the time of maturity by two fungi—*Cladosporium herbarum* (Pers.) Lk. and *Diplodia phaseolina* Sacc.

PIPER BETLE LINN. ICMO, BETEL PEPPER

On dead leaves of *Piper betle* Linn. may be found *Oospora perpusilla* Sacc.

PISUM SATIVUM LINN. PEA

POWDERY MILDEW: ERYSIIPHACEAE

Symptoms.—The powdery mildew may be very destructive, covering leaves, stems, and fruit. It is similar to that discussed under tomato.

Causal organism.—As yet no perfect stage of the fungus has been observed. Conidia and conidiophores are produced in abundance as on tomato.

Control.—Dusting with sulphur or the use of any standard fungicide is recommended.

PSOPHOCARPUS TETRAGONLOBUS DC. WINGED BEAN, CALAMISMIS

ORANGE GALLS: WORONINELLA PSOPHOCARPI RACIBORSKI

Symptoms.—The leaves, stems, and pods are seriously attacked. Leaves may be entirely covered with the yellowish to orange rustlike pustules. They are more abundant on the lower surface, but are also found on the upper. Growth of the younger leaves is retarded, and they may assume abnormal shapes or become thickened. The characteristic, rustlike pustules are produced on the stems. The growth of stems may be entirely stopped. They often become gnarled, twisted, and abnormally enlarged. Large pods may be entirely covered with the yellowish to orange pustules, making them undesirable for use. Growth of smaller pods may be checked or they may grow abnormally, producing malformed, unsalable pods (Plate XV, fig. 2).

Causal organism.—A section through galls in the plant shows the abnormal formation of the host tissue. In the center of the

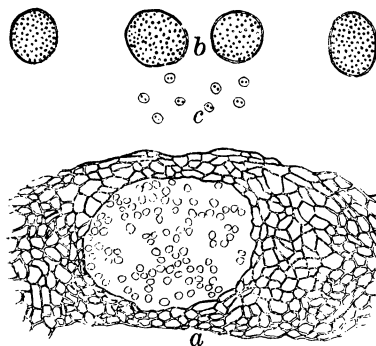

FIG. 27. *Woroninella psophocarpi* Rac. a. cross section of gall from leaf, showing production of sporangia ($\times 80$); b, sporangia ($\times 325$); c, zoospores ($\times 325$).

galls is a cavity with the orange-colored spores, sporangia (fig. 27). These sporangia may germinate in one hour. The contents break up into small protoplasmic masses, which issue from an opening in the wall of the sporangia as free-swimming swarm spores. They are pear-shaped, rounded below and pointed above, and 6 to 8 microns long by 3 to 3.5 microns wide (fig. 27). Two short flagella, 5 to 8 microns long, are fastened a little below the middle of the swarm spore. After a time the swarm spores come to rest and infect the host plant, producing roundish protoplasmic bodies, which displace the host cell protoplasm. This protoplasmic mass contains an orange pigment. It develops and grows in the infected region, finally dividing into many cells. After a second division these cells produce a thick yellow membrane. These bodies are the sporangia of the parasite (fig. 27). They are usually roundish, 20 to 25 microns in

diameter, but may be irregular with corners, 16 microns wide by 50 microns long.

Control.—In severe cases of infection spraying may be highly desirable. Plants should be sprayed with Bordeaux mixture at the slightest indication of the disease. Spraying should be carried on at intervals of a week. Crop rotation also should be practiced. Badly diseased plants should be collected and burned.

RAPHANUS SATIVUS LINN. RADISH

BACTERIAL SOFT ROT: *BACILLUS CAROTOVORUS* JONES

Symptoms.—A bacterial rot of the root frequently occurs. The rot starts while the radishes are still in the ground, and in advanced cases the entire roots disintegrate into a soft mass.

Causal organism.—The rot is due to bacteria, being similar to the root rots produced by *Bacillus carotovorus* Jones. Culture characters have not been worked out, so no definite identity of the organism can be given.

Control.—Diseased carrots should not be allowed to disintegrate in the field, but should be collected and burned. If the field be infected with the bacteria, crop rotation will have to be practiced. When carrots are stored, care should be taken to avoid injuries. The surface of the root should be allowed to dry in the sun, and storage should be in a well-ventilated place.

SACCHARUM OFFICINARUM LINN. SUGAR CANE

BLIGHT: *RHIZOCTONIA*

Symptoms.—During excessively damp weather and in thick plantings sugar cane may be attacked by a *Rhizoctonia*, which kills the young leaves and eventually the entire plant. The infected portions assume at first a watery appearance, then turn brown, and fall over. Brown sclerotial bodies are produced over the old infected parts (Plate XVI, fig. 1).

Causal organism.—The fungus spreads over the tender leaves and penetrates and causes the death of the cells. No spores have been observed; however, sclerotial bodies are formed in abundance. Good growth is produced on potato agar. In young cultures a rather coarse mycelium is produced, and in older cultures the sclerotial bodies are formed. They are white masses at first, but turn brown and hard when older.

Control.—Infected plants should be destroyed. Plantings should not be too thick.

LEAF SPOT: BAKEROPHOMA SACCHARI DIEDICKE

Symptoms.—This is a very common and widely spread spot, affecting the physiological function of the plants and thereby undoubtedly lowering the sugar content of the cane. The base of the leaf blade and the upper portion of the sheath on each side of the ligule are affected. Spots are confined on the lower leaf blade chiefly to the midrib. They are elongated, parallel with the margin, from 1 to 4 millimeters in length, and have a minute whitish center bordered with red or often with black. The whitish center is usually rounded and slightly raised, being made up of the spore-bearing body. The spots are found on both surfaces of the midrib of the leaf, being more abundant on the upper surface, and a few may be found outside of the midrib. Spots on the upper portion of the leaf sheath are similar to those on the leaf blade and are found on both surfaces. As a rule, they do not spread to the lower portion of the sheath or far out on the blade (Plate XVI, fig. 4).



FIG. 28. *Bakerophoma sacchari* Diedicke.
Various types of conidia (\times
1,000).

Causal organism.—An oval pycnidium is found in the center of each spot. Within the pycnidia are numerous small, elongated, hyaline, one-celled spores (fig. 28).

Control.—The disease is not serious enough to warrant any special control. General sanitation methods will keep the disease at a minimum.

LEAF SPOT: CERCOSPORA

Symptoms.—A common leaf spotting, most injurious during the rainy season, is caused by several species of this genus in the Philippine Islands. Generally not a great deal of damage is done to the cane. The vitality of plants is lowered, and the green sugar-forming portion of the leaf is reduced, thereby lowering the sugar content of the cane. Outer or older leaves are most severely attacked, while the inner young leaves are free from disease. Leaves infected by the common *Cercospora* are at first spotted with an irregularly circular yellowish spot. On the lower surface of the spot is a light-colored gray to brownish dust made up of conidia and conidiophores. Spots, as they grow older, become spotted with deep red to purple, or the center becomes deep red to purple surrounded with yellow. In extreme cases spots run together, enlarge, forming irregular, long deep red to purple blotches usually bordered with yellow.

and may cover a large portion of the leaf. On the under surface of these spots is developed the light gray to brownish dust, which contains the same spores as found on the younger spots (Plate XVI, fig. 2).

Causal organism.—The conidia are produced in abundance on the lower surface of the leaves. Conidia are typically elongated with tapering ends, hyaline, and four- to five-celled (fig. 29). The conidiophores are produced in groups from the stomata. They are rather irregular, brownish, and septate.

Control.—The disease is not serious enough to warrant a specific control. General sanitation and the growth of resistant varieties are usually sufficient. The native cane is generally attacked less than the Hawaiian cane. In severe cases of infection all infected leaves should be burned after harvest.

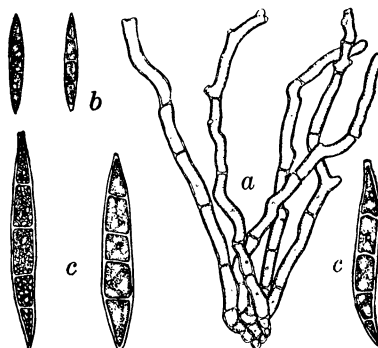

FIG. 29. *Cercospora*. On *Saccharum officinarum* Linn. a, group of conidiophores ($\times 320$); b, conidia ($\times 320$); c, conidia ($\times 640$).

LEAF SPOT: PHYLLACHORA SACCHARI P. HENNINGS

Symptoms.—This is a rather uncommon and nondestructive leaf spotting. The disease is characterized by the production of a black stromatic mass extending through the leaf. Stromata are sparingly scattered on the leaf surface. *Phyllachora sacchari spontanei* Syd. is found in greater abundance on the wild sugar cane, *Saccharum spontaneum* Linn.

Other leaf spottings are present, do little or no damage, and as yet have not been identified.

RIND DISEASE: MELANCONIUM SACCHARI MASSEE

Symptoms.—This stem disease is common in many fields. It does most damage among plants that lack vigor, due to poor cultural methods. In well-kept fields the disease is only slightly in evidence, and little damage is done. Entire fields of weakened cane may be killed by the fungus. Diseased canes at first are prematurely yellowed and later the leaves dry, followed by the death of the plant. In the later stages tips of infected shoots shrivel. Finally the entire cane shrivels and turns brown to black. During the early stages no fruiting bodies have been

observed, but in later stages at first minute, raised black specks are produced under the surface at the nodes and internodes. These spots then burst open, exposing a mass of black spores. Under favorable conditions the ruptured black spots produce curved, mucilaginous, threadlike masses of spores, from 1 to 4 millimeters in length. At first the interior of diseased canes may be reddened; later it is browned.

Frequently only injured tips of stalks become infected. These diseased tips shrivel up and produce the characteristic spore formation. Secondary shoots often arise below the diseased tip, producing a much-branched cane (Plate XVII, fig. 2).

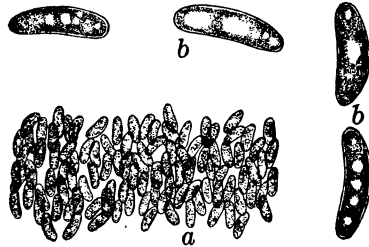

FIG. 30. *Melanconium sacchari* Massee. a, mass of conidia, composing hairlike strand ($\times 300$); b, conidia ($\times 900$).

Causal organism.—The hairlike strands are made up of thousands of one-celled, elongated olivaceous spores (fig. 30). No ascigerous stage has been observed.

Control.—The chief control consists in proper cultural methods, which will produce a healthy vigorously growing cane that will withstand disease. As far as possible both mechanical and insect injuries should

be avoided. Only cuttings from healthy plants should be used. In severe cases of infection the cuttings should be disinfected by dipping in Bordeaux mixture before planting. All diseased cane should be collected and burned, since the fungus lives readily as a saprophyte and produces millions of spores to re-infect the newly planted cane.

ROOT DISEASE: DICTYOPHORA PHALLOIDEA DESVAUX

Symptoms.—Stinkhorns have been observed growing at the base of plants or on the roots. This fungus is not common and is chiefly found during the rainy season. Little damage is done.

ROOT DISEASE: MARASMIUS

Symptoms.—A species of the fungus *Marasmius* has been observed growing from the roots near the base of plants and also as a saprophyte on the lower portion of stems. The disease is more abundant during the rainy season. Little damage is done. Small whitish spore-bearing bodies of the family Agariaceae are produced on infected portions.

ROOT GALLS: NEMATODES: HETERODERA RADICICOLA GREEF ET MÜLLER

Symptoms.—Root galls formed by nematodes are found, but little damage has been reported. The galls produced are similar to those discussed under tobacco.

ROOT PARASITE: AEGINETIA INDICA LINNAEUS

Symptoms.—This flowering plant, one of the broom rapes, may cause destruction of cane. The plant is a root parasite, sapping the vitality of the sugar cane.

RUST: PUCCINIA KUEHNII (KRUEG.) BUTLER [UREDO KUEHNII (KRUEG.) WAKK. ET WENT.]

Symptoms.—This rust may be abundant on the leaves of sugar cane and cause damage by lowering the vitality of the plants. Sori are produced in greatest numbers at the base of the leaf blade near the ligule, but sori may be produced on any part of the leaf blade and on either side. Characteristic bursted, slender, brownish rust pustules from 2 to 5 millimeters in length are produced (Plate XVI, fig. 3).

Causal organism.—The spores are produced in groups underneath the epidermis, which later bursts, due to the growth of spores. The uredospores are produced in abundance. They are large, more or less ovate, yellowish and with numerous thick spines. Germination takes place readily in water overnight (fig. 31).

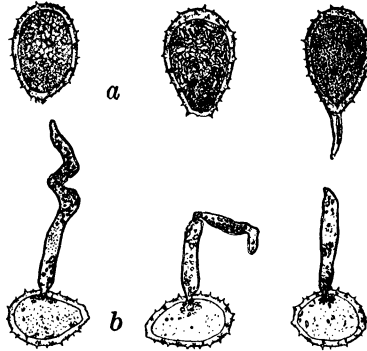

FIG. 31. *Puccinia kuehnii* (Krueg.) Butl. a, uredospores (x 320); b, germinating uredospores (x 320).

Control.—General sanitation and cultural methods will keep this disease at a minimum.

SEREH DISEASE

Symptoms.—This serious cane disease seems to have made its appearance in the Philippines, and great care should be exercised that it does not spread. The symptoms vary according to the stage of the disease, and have been fully described in Java; the same characters are present in the Philippines.

Plants slightly attacked show little or no external disease characters. In some cases the internodes at the top of the plants are somewhat shortened. The internal characteristics are a

reddening of the fibrovascular bundles that arise from the leaf sheaths at the nodes and a gumming of these bundles, which can be observed only under the microscope. The reddening may extend for some distance down the cane.

A medium attack of the disease is characterized by a production of many buds and sprouts from the upright stems. Such plants have a more or less bushy appearance, due to the shortened internodes and the abnormal production of shoots. Diseased stems are somewhat shorter than the normal ones. Frequently a mass of adventitious roots is developed from the nodes under the leaf sheaths.

The worst stage of the disease is the most characteristic. Few or no upright stems are produced in a field that is entirely diseased. Other fields may have diseased plants scattered here and there. This condition is due to the shortening of the internodes and a consequent lack of production of upright stems. Leaves arising from these close nodes are necessarily produced in a bunch and such a plant has the appearance of a fan. Shoots also may arise from these diseased and stunted plants, which make them appear like a bunchy grass. A grass in Java, *Andropogon schoenanthus* Linn., called "sereh" is similar in appearance to these diseased canes, consequently the name "sereh" has been used for diseased cane. Severely diseased plants also may have an abundance of adventitious roots produced from the nodes under the leaf sheaths.

In the Philippines the disease has been observed to be more abundant in ratoon fields. It is often spread by cuttings. Cuttings of a plant showing only the first symptoms of the disease will produce plants that exhibit the disease in its medium stage. Cuttings from plants with medium attacks produce plants that show the severe case of disease. The disease may in this way become more and more severe.

Causal organism.—Investigation of this trouble has just been started in the Philippines. As yet no organism has been associated with the disease in other countries. In some cases it appears that the disease is infectious, for it seems to spread. It may be spread by planting cuttings from diseased plants, but it has not been shown that a healthy plant can contract the disease from a diseased plant. In Java the disease is assigned to a deterioration of the cane.

Control.—No cane should be imported from countries in which the disease exists. Care should be taken that the disease is not spread from infected plantations to noninfected ones. Cut-

tings should be made only from healthy canes. All diseased plants should be dug up and burned. After the cane has been cut in diseased fields, these fields should be burned over. In severely infested sections of Java, healthy cuttings are obtained for plantings from fields that have been planted at an elevation of 610 meters. Conditions at this elevation are such that perfectly healthy and vigorous canes are produced. At the age of 6 months such canes are used for cuttings. This is done to avoid all possibilities of deterioration of the cane. It does not appear that such methods are necessary as yet for plantations in the Philippines. Sanitation measures, such as burning over diseased fields after digging up and burning all diseased plants along with the strict selection of cuttings from healthy, vigorous plants, ought to hold the disease in check.

The growth of resistant varieties will also aid in controlling the disease.

SMUT: *USTILAGO SACCHARI* RABENHORST

Symptoms.—This is a smut that seems to be epidemic in its attacks. During seasons favorable to its growth much damage has been done. The disease does only slight damage in well-kept plantations. The tips of young shoots are more usually attacked. They develop into long, slender, curved, shrunken, dusty, blackened masses. These shoots are often from 30 to 60 centimeters in length and are covered with spores. The diseased portion may extend downward in the shoot inside the mass of leaf sheaths (Plate XVII, fig. 1).

The disease also occurs, often in abundance, on the wild sugar cane, *Saccharum spontaneum* Linn.

Causal organism.—Spores are single-celled, spherical, smooth, and dark brown. They germinate readily in water overnight, producing a hyaline promycelium with elongate hyaline sporidia. The promycelium is frequently branched (fig. 32).

Control.—Strict sanitation methods consisting in the destruction, by burning, of all infected portions should be practiced. All diseased material found on wild sugar cane also should be

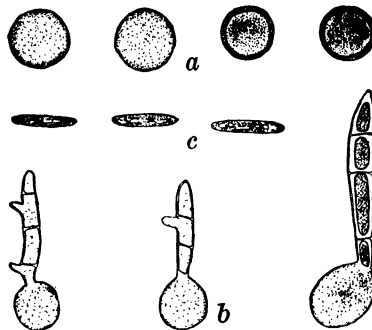

FIG. 32. *Ustilago sacchari* Rabh. a, spores ($\times 340$); b, germinating spores with promycelia ($\times 340$); c, sporidia ($\times 340$).

destroyed, for the disease spreads from wild to cultivated cane. Only cuttings from healthy plants should be used. In severe cases of infection crop rotation will have to be practiced.

SOOTY MOLD: MELIOLA ARUNDINIS PATOULLARD

Symptoms.—Leaves and even whole plants of sugar cane may be frequently covered with a superficial black mold. This mold is produced on the sugary excretion produced by aphids and mealy bugs. The fungus is not parasitic, but causes some damage by shading the chlorophyll of the leaves, thereby reducing their full working capacity.

Causal organism.—The mycelium is dark brown with characteristic hyphopodia. The perithecia are produced among the mycelial strands, and within the perithecia are globular, hyaline asci with brown septate ascospores.

Control.—The control of aphids and mealy bugs will entirely check this disease.

STEM ROT: BACTERIAL

Symptoms.—Young weakened cane may rot from the tip of the stem downward. The disease is only present in poorly kept plantings and seems to be most prevalent on the ratoon cane. It appears to be due to bacteria.

Other fungi found on weakened and dead leaves are *Coniosporium vinosum* (B. et C.) Sacc., *Coniosporium extremorum* Syd., *Apiospora camptospora* Penz. et Sacc., *Melanconium lineolatum* Sacc. and *Haplosporella melanconioides* Sacc., forma, are found on dead stalks of cultivated cane. *Haplosporella melanconioides* Sacc. is found on dead stalks of wild cane.

SESAMUM INDICUM LINN. SESAME, LINGA

LEAF SPOT: CERCOSPORA SESAMI A. ZIMMERMAN

Symptoms.—A common and destructive spot-producing fungus, affecting leaf, petiole, stem, and capsules. Spots are scattered over the leaf surface and are from 1 to 4 centimeters in diameter. They are irregularly circular, and have gray centers, bordered with brownish to purplish rings. Frequently older spots may have concentric rings of purplish brown. Spots often run together, until finally the entire leaf is covered with a brownish blotch, with the gray-centered spots bordered with purplish scattered through the brown. The spots on petiole and stem are similar to those on the leaf, except that they are somewhat more elongated and slightly sunken. Spots on the capsule are usually distinctly circular and are sunken and have gray centers bordered with brown.

Causal organism.—The blackish dust in the center of the gray is made up of conidiophores and conidia. Conidiophores are produced in groups; they are septate and light brown. The conidia are typical *Cercospora* spores, hyaline, tapering, and much elongated, often being ten-celled.

Control.—The disease may be controlled by ordinary crop rotation.

POWDERY MILDEW: ERYSPHACEAE

Symptoms.—During the cool season of the year leaves may be attacked by a powdery mildew. The upper, and sometimes the lower, surface of the leaf presents the characteristic powdery appearance.

Causal organism.—Conidiophores and conidia of the Erysiphaceae type are produced in abundance. No perithecia and asci with ascospores have been observed.

Control.—The disease is seldom serious enough to warrant any special control. In severe cases of infection, dusting with sulphur or spraying with any standard fungicide will control the fungus.

Other fungi found on dead and dying stems are *Phoma sesamina* Sacc., *Gloeosporium macrophomoides* Sacc., *Vermicularia sesamina* Sacc., and *Helminthosporium sesameum* Sacc.

SOLANUM MELONGENA LINN. EGG PLANT

BACTERIAL WILT: BACILLUS SOLANACEARUM ERW. SMITH

Symptoms.—This bacterial wilt is common on all solanaceous plants in the Philippines. It is often the limiting factor in the production of eggplants. The disease is similar to that of tomato and is more fully described under that heading.

LEAF SPOT AND FRUIT ROT: GLOEOSPORIUM MELONGENAE SACCARDO

Symptoms.—This disease is found upon the leaf and fruit. On the leaf the characteristic irregular spots with brownish gray centers bordered with dark brown are formed (Plate XVIII, fig. 1). Within the center of spots, in the brownish gray, are produced numerous minute black specks, the fruiting bodies of the fungus. Diseased fruits have large, irregular, sunken light brown areas bordered with a darker brownish ring. Within these sunken spots black specks are produced in large numbers. Fruits may be entirely rotted, due to the attacks of the fungus (Plate XVIII, fig. 3). The disease is most severe during the rainy season.

Causal organism.—The minute black specks produced in the diseased parts are pycnidia. They are dark brown, spherical, and contain a mass of one-celled, somewhat elongated, olivaceous spores. In pure culture, at first, a growth of white mycelium develops. Later this white mass changes into a dotted mass of black pycnidia. Characteristic diseased lesions may be produced by inoculation with a pure culture.

Control.—The most important control consists in the destruction by burning of all the diseased leaves and fruit followed by crop rotation. If severe cases of infection have been experienced, more drastic control measures must be practiced. These consist in the treatment of seed with formalin, 1 to 2 per cent for fifteen minutes, dipping of seedlings in Bordeaux mixture or a weak solution of copper sulphate before planting, and finally by spraying with Bordeaux mixture at intervals of from two weeks to one month.

LEAF SPOT: SARCINELLA RAIMUNDOI SACCARDO

Symptoms.—A leaf spot frequently found on dying leaves of eggplant, but doing little damage. Small irregular blackish spots are produced on the surface of dying leaves. *Diplodina degenerans* Diedicke and *Phoma solanophila* Oud. are found on decaying fruit.

SOLANUM TUBEROSUM LINN. POTATO

BACTERIAL WILT: BACILLUS SOLANACEARUM ERW. SMITH

Symptoms.—The common bacterial wilt of solanaceous plants is particularly severe on potatoes, often limiting their production. The Irish potato is not acclimatized in this country except in the higher altitudes; consequently in its weakened condition it is subject to the attacks of soil bacteria.

Diseased plants first wilt and then fall over. In advanced cases the lower portion of the stem may be discolored. The stem end of diseased tubers, when sectioned, shows a blackened ring in the vicinity of the vascular bundles just below the surface. In advanced stages the tuber rots. In severe cases the entire crop may be destroyed.

Causal organism.—The organism producing this disease is the same as that attacking other solanaceous plants. The wilting is produced by the bacteria clogging up the vascular bundles. The bacteria pass from the vascular system of the stem into

the tubers, resulting in the production of the characteristic blackened ring and the consequent rotting.

Control.—In newly developed sections where potatoes can be grown, the chief precaution to be taken is to keep the bacteria out of the soil. Once the soil becomes heavily infected, it is practically impossible to grow potatoes as a regular crop. Careful seed selection will reduce the chances of their introduction. Avoid using seed potatoes from fields or crops known to be diseased. If the source of the seed be not known, all seed potatoes should be carefully examined by cutting a slice from the stem end. If a black ring be found just under the surface or if a rotting have started, such potatoes should be discarded. All wilted plants should be dug and burned as soon as discovered. Insects attacking potatoes should be controlled, since they spread the disease. In cases of severe infection, a crop rotation of five years must be practiced. During this rotation no tomatoes, eggplants, peppers, tobacco, or other solanaceous plant should be grown. Diseased tubers should never be stored with the healthy.

BLACKLEG, OR POTATO STEM ROT: *BACILLUS PHYTOPHTHORUS APPEL*

Symptoms.—This disease is probably present in the Philippines. The characteristic symptoms of wilting and yellowing of leaves, the blackened rotten stem, and the rotted tubers have been frequently observed. It may be that this disease, as described here, is the same as the bacterial wilt, only in a different state of development.

Causal organism.—No work has been done with the organism.

Control.—The control is similar to that discussed under bacterial wilt.

BLIGHT: *PHYTOPHTHORA INFESTANS* (MONT.) DE BARY

Symptoms.—This disease has been observed only in the mountain provinces, where it was probably introduced on seed potatoes. Black blotches are produced on the leaves. These spots may have a downy fungus mass growing on the under surface. Diseased stems turn black and rot. A soft ill-smelling rot may be produced in the tubers.

Causal organism.—The downy growth is made up of much-branched conidiophores with hyaline, lemon-shaped conidia.

Control.—Spraying with Bordeaux mixture will have to be practiced in severe cases of infection. Crop rotation also should be practiced.

THEOBROMA CACAO LINN. CACAO

BLACK ROT OF PODS: PHYTOPHTHORA FABERI MAUBLANC

Symptoms.—This destructive disease causes a loss of one-half of the cacao fruit in certain sections of the Philippines. The

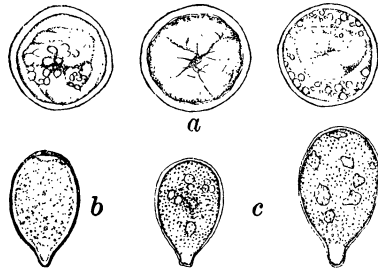

FIG. 33. *Phytophthora faberi* Maubl. *a*, Chlamydospores ($\times 325$) from pure culture; *b*, conidium ($\times 325$) from pure culture; *c*, conidia ($\times 325$) from surface of diseased fruit.

fungus attacks the fruit at any stage during its growth; however, the greatest damage is done to the young fruits. At the point of entrance of the fungus a minute black spot is first developed. This spot gradually enlarges, until the entire pod becomes blackened. At this stage, during damp weather, a dense mass of mycelium is formed on the surface, the latter producing conidiophores and conidia (Plate XIX, fig. 4). A section of diseased fruit shows that the mycelium invades the rind, passing into the seed. Finally both rind and seed become rotted with a more or less dry rot. The diseased pods may fall or remain upon the tree, drying up and becoming mummified. Flowers and stems also may be attacked and killed by the fungus.

Causal organism.—The oval, hyaline, much-granular conidia are produced in abundance from the conidiophores (fig. 33). These spores are produced on the surface of the fruit, whence they are blown to other fruits, causing new infection. Microscopic examination of the interior of diseased pods shows an abundance of mycelium and chlamydospores (fig. 33). Antheridia and oögonia have not been observed. The chlamydospores are resting spores and are capable of producing disease after the pod disintegrates. The fungus grows well in pure culture, producing a white, downy growth. Inoculation experi-

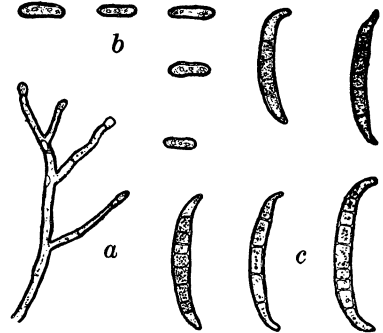

FIG. 34. *Fusarium theobromae* App. et Strunk. *a*, portion of conidiophore ($\times 315$); *b*, microconidia ($\times 315$); *c*, macroconidia ($\times 315$).

ments have been very successful. Typical disease was produced on pods and their peduncles.

Control.—The disease can be easily and economically controlled by spraying with Bordeaux mixture. Eight to ten sprays during the season are sufficient. Of these sprays, five to seven should be applied during the rainy season and three during the dry season. It is best to add a sticker of resin and salsoda during the rainy season. The cost of spraying is 2 centavos per tree for each spray. Sanitation should be practiced along with spraying. This consists in collecting and burning all diseased pods hanging on the tree and those on the ground. All diseased branches should be removed. Cacao plantings should not be too thick nor should the shade be too dense, so that there will be plenty of aëration.

The rotting of diseased pods may be hastened by the entrance of other fungi. These fungi found on decaying fruits are *Fusarium theobromae* App. et Strunk (fig. 34), *Nectria bainii* Masee var. *hypoleuca* Sacc. (fig. 35), *Lasiodiplodia theobromae* (Pat.) Griff. et Maubl.

(Plate XIX, figs. 1, 2, and 3), *Oospora candidula* Sacc., *Physalospora affinis* Sacc., *Aspergillus delacroixii* Sacc. et Syd., and *Mycogone cervina* Ditm. var. *theobromae* Sacc.

CANKER: PHYTOPHTHORA FABERI MAUBLANC

Symptoms.—The cacao canker may be found on young twigs, older branches, and the trunks of trees. Diseased twigs are characterized by a dying of the tips, browning of the leaves, and a shriveling of the diseased wood. A definite line of demarcation is usually produced showing the limits of the disease. On larger branches and on the trunk more or less blackened cankered areas are produced. These are characterized by a shrinking of the diseased area which may have a definite line of demarcation at the extremities of the diseased portion. Often a cracking and a scaling of the bark are produced in these diseased areas. The infection may spread from diseased pods into the branches or trunk. A true cankered condition is not always produced.

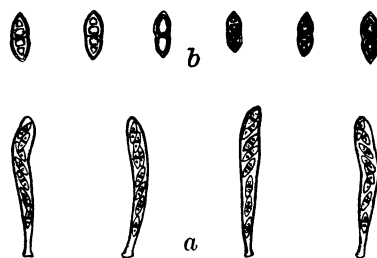

FIG. 35. *Nectria bainii* Masee var. *hypoleuca* Sacc. a, asci with ascospores ($\times 325$); b, ascospores ($\times 650$).

Causal organism.—The causal organism is the same as discussed under the black rot of cacao pods. The mycelium develops primarily internally in the diseased tissues. Little mycelium is produced on the surface, except under excessively damp conditions and when diseased portions are put into a damp chamber. The fungus grows well in pure culture and the disease can be readily produced by inoculation.

Nectria discophora Mont. may be found growing saprophytically on dead stems and it may in some cases follow the *Phytophthora* attack.

Control.—All diseased stems should be removed well back of the limit of infection. Cankered spots on the trunk should be cut out down to the healthy wood. It is advisable to paint the larger wounds with a coal-tar preparation or with a good white-lead paint. Badly diseased trees should be cut down and burned. The control measures discussed under black rot of cacao pods are equally effective in combating this disease.

DIE-BACK

Symptoms.—A die-back of young twigs and limbs is found, but the causal organism has not been determined. Dead twigs and limbs often bear the following fungi: *Botryosphaeria minuscula* Sacc., *Cyphella holstii* Henn., and *Ophionectria theobromae* (Pat.) Duss.

DRY SOOTY ROT: LASIODIPLODIA THEOBROMAE (PAT.) GRIFFON ET MAUBLANC

Symptoms.—This fungus frequently follows the attack of *Phytophthora*. It may produce a rot of older fruits without the presence of any other fungus attack. The first sign of disease is a blackening about an injury. This blackened area spreads, until the entire pod is diseased. In this stage the disease appears somewhat like the early stages of the *Phytophthora* rot. In the later stages a black sooty mass of spores is produced over the diseased fruit. At first only one portion of the fruit shows this black mass of spores, but finally the entire fruit is covered. Diseased fruits shrivel and become hard (Plate XIX, fig. 2).

Causal organism.—The black sooty mass is made up of dark brown two-celled spores. Before maturity these spores are one-celled, hyaline, and much-granular. Spores germinate readily in water overnight (fig. 36). A cross section of the diseased pod shows, just below the surface, a series of pycnidia produced in a mass of brown mycelium. The conidia are

formed in abundance among the paraphyses. The fungus grows well in pure culture, producing a thick black growth of mycelium. It is omnivorous, causing dry sooty rots of a number of root crops and fruits. Inoculations with a pure culture obtained from a rotted cacao pod produced the typical disease on cacao, cassava, gabi, and sweet potato. Inoculations with a pure culture obtained from a rotted sweet potato produced the typical disease on sweet potato, cacao, cassava, and papaya.

Control.—The disease gains entrance through injuries on mature fruits and consequently all injuries should be avoided. Diseased pods and other diseased fruits and root crops should be burned. Spraying as discussed under black rot of cacao pods will prevent infection.

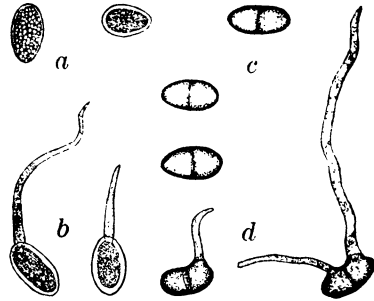

FIG. 36. *Lasiodiplodia theobromae* (Pat.) Griff. et Maubl. from cacao. a, young conidia ($\times 350$); b, germinating young conidia ($\times 350$); c, mature conidia ($\times 350$); d, germinating mature conidia ($\times 350$).

LICHENS

Symptoms.—Lichens are common on the trunk and branches where they produce grayish green blotches. Their presence is not considered extremely harmful, although they do stop up the lenticels and natural openings of the affected portions, thereby interfering with the natural physiological functions of the plant.

Control.—A 6 per cent copper sulphate wash will remedy this condition. Spraying as practiced for the control of the black rot of pods will also be effective in killing the lichens.

VIGNA SPP. COWPEAS

BLIGHT: RHIZOCTONIA

Symptoms.—Discussed under soy beans.

CURLY TOP: FUSARIUM

Symptoms.—Diseased New Era cowpeas are characterized by having shriveled, curled leaves. The plants are stunted, and the flowers are produced in great abundance in a bunched condition. The upper parts of the plants are green and healthy, but the portion of the stem just at and a little above the ground

is attacked by a fungus. The root system is healthy. Isolations from a large number of stems gave a *Fusarium* that produced a pinkish growth in pure culture.

LEAF SPOT: CERCOSPORA

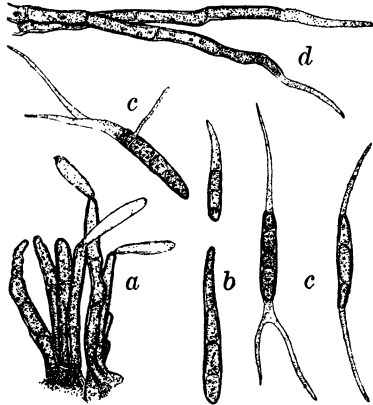

FIG. 37. *Cercospora* on *Vigna sinensis* Endl. a, group of conidiophores with immature conidia attached ($\times 350$); b, conidia ($\times 350$); c, germinating conidia ($\times 350$); d, germinating conidiophores ($\times 350$).

Symptoms.—Leaves may be spotted with definite circular spots from 1 to 3 millimeters in diameter. Spots have gray centers with purplish borders.

Causal organism.—Typical *Cercospora* conidia and conidiophores are developed (fig. 37). The conidia are tapering and usually have from four to six cells. Germination takes place in water overnight. Conidiophores are produced in groups and are light brown and septate. They also may germinate and produce infection.

Control.—Crop rotation will keep the disease at a minimum.

POD SPOT: PHOMA BAKERIANA SACCARDO

Symptoms.—This fungus is found growing on mature pods, where it produces minute black specks.

POWDERY MILDEW: ERYSPHACEAE

Symptoms.—A white powdery mildew may cover all parts of the plant. This disease is not serious and appears during cool dry weather. It has been observed in abundance on *Vigna catjang* Walp.

Causal organism.—Conidia and conidiophores are produced in abundance, but as yet no perithecia have been observed (fig. 38).

Control.—The disease is not serious enough to warrant any special control. Crop rotation should be practiced.

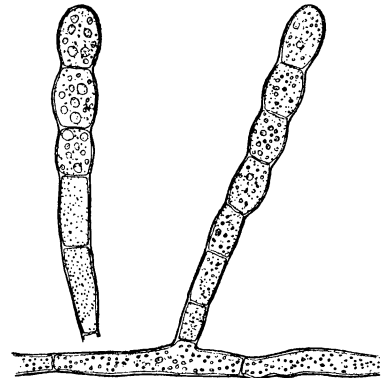

FIG. 38. A species of Erysiphaceae, on *Vigna catjang* Walp. Mycelium and conidiophores with chains of conidia ($\times 325$).

RUST: UREDO VIGNAE BRESADOLA

Symptoms.—This is a rust that may do severe damage to the plants. Usually it is not common enough to be very destructive. Characteristic, brown rust sori are produced on the under leaf surface.

XANTHOSOMA SAGITTIFOLIUM SCHOTT. YAUTIA

LEAF SPOT: VERMICULARIA XANTHOSOMATIS SACCARDO

Symptoms.—A small leaf spot sparingly scattered over the leaves. Little damage is done.

Yautia was mentioned before as a plant to replace the common Philippine gabi, the latter being badly infected with disease. Yautia is entirely free from the attacks of *Phytophthora*.

ZEA MAYS LINN. CORN, MAIZE

BLAST OF KERNELS: FUSARIUM

Symptoms.—Individual mature kernels will frequently swell, burst open, and expose the starch. The starchy blasted area is usually covered with a pink growth of mycelium (Plate XX, fig. 3).

Causal organism.—A *Fusarium* is associated with the disease. The mycelium penetrates the grains and produces spores on the surface.

Control.—The disease is usually not severe. Planting should not be too thick, so as to allow for plenty of aëration.

DOWNY MILDEW: SCLEROSPORA MAYDIS (RAC.) BUTLER

Symptoms.—This is a serious corn disease found in India, Java, the Philippines, and undoubtedly in other tropical countries. In Java recent work has shown that the disease is due to *Sclerospora javanica* Palm, which is not identical with *Sclerospora maydis* (Rac.) Butl. In the Philippines we have the same fungus described by Butler of India, *Sclerospora maydis* (Rac.) Butl. There appear to be in the East two mildew diseases, identical in appearance, but caused by two different fungi.

Downy mildew of corn is a serious disease in the Philippines, often killing entire portions of fields. It is most severe during the rainy season. Young plants, from 10 to 60 centimeters in height, first exhibit the disease. Upper younger leaves are the first to become affected. Lower outer leaves are normal. Diseased leaves are characterized by the production of white stripes running parallel with the margin (Plate XX, fig. 2). Frequently the entire young leaves are whitened. This diseased

condition is a chlorotic one, due to the disappearance of the chlorophyll. On both surfaces of diseased leaves, more abundant, however, on the lower surface, a downy appearance is produced by the mass of conidia and conidiophores. At a distance, affected plants look pale. They are stunted and have a bunched growth, due to the checking of growth and frequently a shortening of the internodes. Such plants produce the male inflorescence prematurely. As a rule, no grain is produced. Badly diseased plants wither and die before the

normal plants are ready for harvest. In severe cases of infection from 60 to 70 per cent of the crop may be destroyed.

The disease has also been observed on teosinte, *Reana luxurians* Dur.

Causal organism.—Conidiophores and conidia are hyaline. Conidiophores are thick, short, unbranched at the base, with short branches near the tip. They are produced in abundance, arising from the stomata (fig. 39). On the end of the short branches are produced sterigmata, each of which bears a single conidium. Conidia are hyaline, thin-walled, spherical when young, but oval when mature (fig. 39). Conidia germinate readily by the production of one or two germ tubes. Germinating conidia are found frequently on infected leaves. Oöspores have not been found.

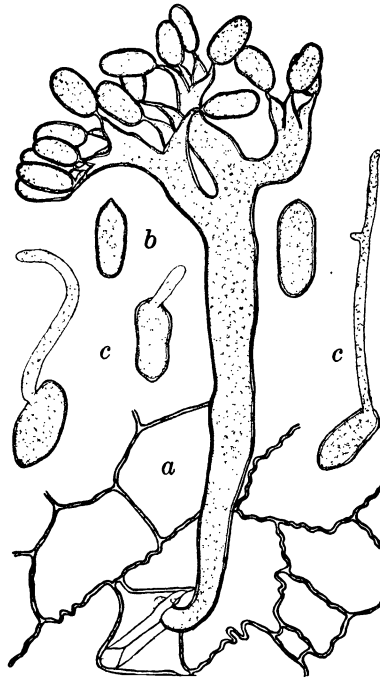

FIG. 39. *Sclerospora maydis* (Rac.) Butl. a, conidiophore with conidia, arising from stomata of leaf ($\times 320$); b, conidia ($\times 320$); c, germinating conidia ($\times 320$).

Control.—The method of infection and spread of the disease is unknown; therefore, no control can be indicated except to suggest sanitation by burning all infected plants and by crop rotation.

DRY ROT: STERILE FUNGUS

Symptoms.—Kernels on the ear are destroyed by a dense felty mass of mycelium. The ear is attacked before maturity

and during damp weather. Diseased ears may be entirely covered with the fungus growth or only partially covered in blotches. Infected kernels do not mature, and the starch is partially consumed and becomes powdery.

Causal organism.—No spores are developed. A sterile mass of mycelium covers the grain. The fungus grows readily in pure culture, producing a thick woolly mass.

Control.—The disease is only severe during damp, hot weather. Corn should not be planted too closely, so as to allow for plenty of aëration.

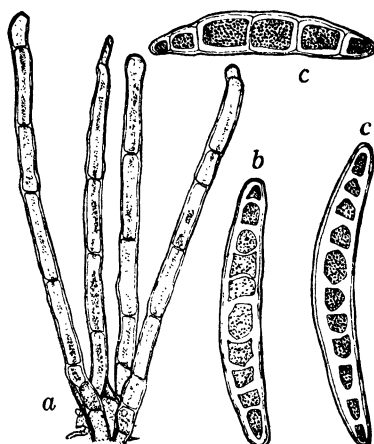

FIG. 40. *Helminthosporium inconspicuum* C. et E. a, group of conidiophores ($\times 320$); b, conidium from tassel of corn ($\times 320$); c, conidia from leaf of corn ($\times 320$).

LEAF SPOT: *HELMINTHOSPORIUM INCONSPICUUM* COOKE ET ELLIS

Symptoms.—This is a common disease in the Philippines, which at times may be extremely destructive. At the College of Agriculture entire plots of field and sweet corn have been destroyed. The disease is especially severe on newly introduced corn that is not acclimated and is in a weakened condition. It is present on the native corn, but generally does little damage. Leaves and tassels are attacked. On the leaves are produced at first minute, roundish brown spots, which gradually increase in size, becoming somewhat oval, the long axis of the spot being parallel with the veins (Plate XX, fig. 1). Spots may increase in size, elongating into stripes, or may run together, covering large surfaces of the leaf. Old spots and stripes have a lighter yellow

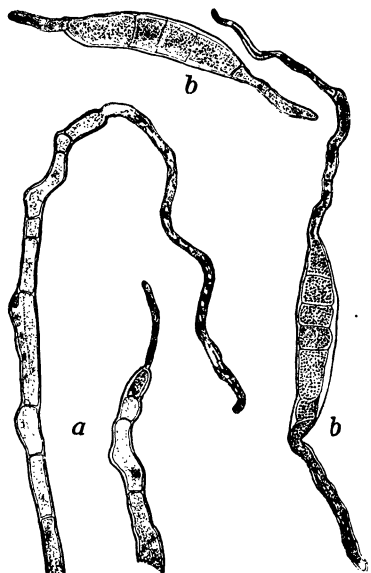

FIG. 41. *Helminthosporium inconspicuum* C. et E. a, germinating conidiophores ($\times 320$); b, germinating conidia ($\times 320$).



FIG. 42. *Helminthosporium inconspicuum*
C. et E. Direct penetration of
host tissue ($\times 325$).

diseased plants should not be put, the same year, upon fields to be planted with corn.

Helminthosporium curvulum Sacc. has been reported from the tassels of corn.

SMUT: *USTILAGO ZEAE* (BECKM.) UNGER

Symptoms.—This disease has been reported in the Islands. It is characterized by the production of conspicuous black masses on the ear and tassel of corn. The disease may be present also on the leaves. These swollen masses are at first covered with a white membrane, which later becomes black, owing to a maturing of the spores. When this membrane breaks, a powdery black mass of spores is exposed.

lowish, to gray center, bordered with brown. In the center of old spots is produced a black mold made up of conidiophores and conidia. A black mold is produced on the tassel.

Causal organism.—Conidiophores are brownish and produce large, septate, curved brown conidia (fig. 40). The conidia germinate readily in water, producing from one to two germ tubes. Conidiophores may also germinate and produce infection (fig. 41). Penetration into the leaf may be either by way of the stomata or by direct penetration into the leaf tissue (figs. 42 and 43).

Control.—Crop rotation should be practiced. Compost made of

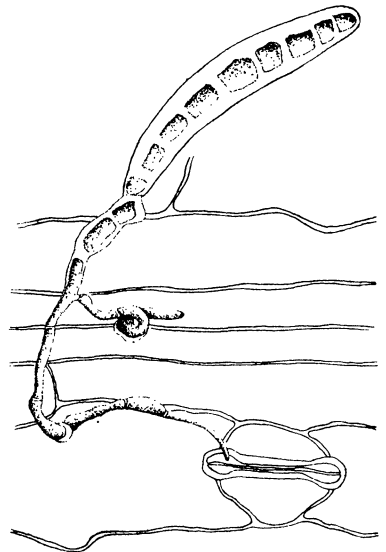

FIG. 43. *Helminthosporium inconspicuum*
C. et E. Germinating spore
($\times 345$), germ tube about to
enter stomata.

Causal organism.—The spores are brownish and usually spherical and are covered with blunt spines. They germinate readily in water, producing a promycelium with sporidia.

Control.—Collect and burn all diseased parts. Crop rotation should be practiced.

Clasterosporium maydicum Sacc. is found on leaves and is often associated with *Helminthosporium inconspicuum* C. et E. *Leptosphaeria orthogramma* (B. et Br.) Sacc., *Broomella zae* Rehm., *Phyalospora linearis* Sacc., and *Acerbia maydis* Rehm. are found on corn trash during decomposition.

CONTROL OF PLANT DISEASES

GENERAL DISCUSSION

The control of plant diseases involves primarily a prevention of infection by the fungus. Before the method of prevention can be fully understood, the true nature and cause of a disease must be clear. The Filipino farmer must realize that plant diseases are caused by specific organisms and that these diseases can be communicated from one plant to another. The discussion of these various diseases has been taken up to point out their nature, to show how to recognize them, to indicate the damage they do, and to give the means of controlling them.

PLANT SANITATION

Many of the diseases discussed need no specific control measures. One of the most important general control measures is that of plant sanitation. This term includes the destruction of the diseased parts, together with the organism, and other allied practices. It must be remembered that the organism producing disease is present on the infected portions and that most of these organisms are capable of living in the soil for some time. Consequently in cases where it is practicable, all badly diseased plants should be destroyed by burning. This will reduce the number of spores and spore-bearing bodies that would have accumulated in the soil. If the fungus be allowed to accumulate in the soil from year to year and especially if the same crop be grown continuously on one piece of land, serious epidemics of disease are apt to take place.

CROP ROTATION

The majority of fungi can develop only upon specific hosts and live in the soil only for a short period of years. This brings up the second and possibly most important sanitation measure, that of crop rotation. Since a crop may be attacked by a definite

fungus that will not attack other plants, this fungus can be largely kept out of the soil by a system of starvation brought about by crop rotation. As a rule, the majority of the fungi can only live in the soil without their host plant for from one to three years. There are exceptions to this rule, but generally speaking a systematic, two- or three-year, crop rotation will reduce the fungus pests of a specific crop to a minimum and in this way keep the disease at a point where little injury is done. The first consideration from a control viewpoint, therefore, is sanitation, which includes the destruction of diseased plants and fungi by burning, and the second is a systematic system of crop rotation.

CULTURAL METHODS

Another very important consideration is that concerned with the culture of the various crops. By culture methods is meant the proper preparation of the soil, the proper method of planting, the proper distance between plants, the proper amount of shade, the proper soil and locations adapted to crops, and the proper methods of cultivation, pruning, and other practices that will produce a healthy and vigorous plant and one that will give the greatest yield. A healthy, vigorous plant will, to a marked degree, withstand disease; therefore any practice that will produce such a plant will, in the majority of cases, reduce the prevalence and severity of the disease. In the Philippines, on the whole, very poor culture methods are practiced. A large number of cases may be cited, but as examples the culture of coconuts, abacá, cacao, and citrus are sufficient. These plants are usually planted entirely too thick. This thick planting produces humid conditions and a lack of aëration, both of which are highly favorable to disease production. Once a disease becomes established in a thickly planted area, it spreads rapidly from plant to plant. These conditions are true in regard to coconut bud rot, abacá heart rot, and the black rot of cacao. New plantings should be made according to the best-accepted and approved methods of planting. It is usually true that those conditions that will induce a crop to produce at a maximum will also provide conditions that are unfavorable for the production of disease. In proper culture methods trash, consisting of dead portions of plants and other refuse, should never be allowed to accumulate under the plants, for this material affords a favorable place for the hibernation and sometimes the development of many fungi causing plant diseases. Clean culture methods will necessarily reduce the

amount of trash in fields. This practice will greatly lessen the conditions that are favorable for the hibernation and reproduction of fungi and insects. Clean culture is little practiced in the Philippines. It is one of the essentials of good agriculture and should be practiced in the culture of coconuts, abaca, citrus, cacao, coffee, and all other crops when possible. Plantations in which this method of agriculture is practiced obtain higher yields due not only to better culture, but also to the reduction of fungus and insect attacks.

DISEASE-RESISTANT VARIETIES

Certain varieties of plants are less affected by disease than are other varieties. Control of plant diseases by the use of disease-resistant varieties is the cheapest and best method, if such varieties can be obtained. It is not always possible to produce varieties that will resist disease, but the grower should select those varieties that are least subject to attack. Different species of coffee show marked degrees of resistance to rust. *Coffea arabica* Linn. is severely affected, while the *robusta* and *liberica* types are less attacked. Resistance of other plants has been pointed out, and whenever possible these varieties should be planted.

SOIL STERILIZATION

For the control of a large number of fungi specific measures can be carried out on a practical basis. The soil of the tropics contains many soil fungi, some of which are highly destructive to young, tender plant growths. These fungi, as before discussed, include the following: *Rhizoctonia*, *Phytophthora nicotianae* Breda de Haan, *Pythium debaryanum* Hesse, *Sclerotium* and *Fusarium*. All may cause large destruction by damping off seedlings grown in seed beds. This trouble can be easily avoided by soil sterilization. The soil used for the production of seedlings should be sterilized. No practical method of soil sterilization for large areas of soil has been devised. Soil sterilization consists primarily of two methods, namely, by heating the soil directly and by the use of disinfectants.

DIRECT-HEATING METHOD

For the Philippines the best method of soil sterilization by heat consists merely in heating the soil on a piece of sheet iron (Plate XXI, fig. 1). A piece of sheet iron 95 centimeters by 160 centimeters is raised about 50 centimeters above the ground by means of iron posts. Moist garden soil is shoveled on the sheet iron, and a fire is built underneath. In this way the soil

should be thoroughly heated for from thirty minutes to one hour, taking care that the humus is not removed by burning. It is not necessary to burn the soil, but a temperature from 60° C. to 100° C., that is, just high enough so that a person cannot pick up the soil in his hands is sufficient. The sterilized soil should then be shoveled into seed flats that have been thoroughly dried by placing them in the sun or better still those that have been disinfected with a 2 per cent formalin solution. The soil is ready for planting as soon as it cools.

FORMALIN DISINFECTION

Formalin may be used for soil disinfection, but it is not to be preferred to heating, since the soil cannot be used for planting for at least one week after the application. The soil to be disinfected should be thoroughly prepared and placed in seed flats. It is then drenched with a formalin solution composed of 1 part of commercial formalin (40 per cent formaldehyde) to 150 to 200 parts of water. The flats should be covered with cloth or banana leaves for one to two days to retain the fumes. The soil is then aired for one week before sowing the seed.

FUNGICIDES

Certain diseases may be economically controlled by the application of fungicides. It must be remembered that in the majority of cases the fungicides are applied as a preventive. They protect the plant against infection. Once a fungus has gained entrance to a plant tissue, the application of a fungicide will be of no avail. In the control of superficial-growing fungi such as the powdery mildews and sooty molds the fungicide will kill the fungus directly. Spraying must be thoroughly done, so that every part of the plant surface is covered with a film of the preparation. This can be done only by the use of a proper spraying apparatus that will produce a fine mist and thereby cover the plant without drenching. The standard Bordeaux mixture is the best universal spray for the Philippine Islands. For special purposes other sprays may be used.

The cost of spraying cacao trees for the black rot of pods, based on the materials and cost of labor at 10 centavos per hour, is 2 centavos per tree for each application. With ten applications a year the cost would be 20 centavos per tree, or the value of four cacao fruits. Coffee spraying against rust can be satisfactorily done for 20 centavos per tree for the year's spraying.

STANDARD BORDEAUX MIXTURE

Materials.

Copper sulphate (blue vitriol), kilos	1.8
Stone lime, kilos	1.8
Water, liters	190

The amount of copper sulphate can be varied according to the formula given. The weight of stone lime should be equal to or exceed the weight of copper sulphate. The important point to consider in regard to the materials is that good unslaked stone lime must be used. Bordeaux mixture cannot be prepared with air-slaked lime.

APPARATUS

- Two half-barrels with a capacity of about 115 liters, made by sawing in two a 230-liter barrel.
- One 230-liter mixing barrel.
- Two or more wooden pails.
- One strong paddle, about 2 meters long.
- One pair of hand scales.

PREPARATION

1. Dissolve 1.8 kilograms of copper sulphate in hot water, place in half-barrel, and add water to make 95 liters.
2. Slake 1.8 kilograms of stone lime in the second half-barrel and add water to make 95 liters.
3. Mix solutions by having two operators, each provided with a bucket. Dip up equal amounts of the copper sulphate and lime solutions and pour them together, at the same rate, at a height of 60 to 90 centimeters above a mixing barrel (Plate XXI, fig. 2).
4. Mix the whole thoroughly by stirring vigorously.
5. Strain the mixture when putting into the spray tank.
6. Apply to the plants with a good pressure spray pump. Use as soon as made.

If other than the above formula be given, take respective pounds as indicated in formula. For example, to make a preparation containing 1.8 kilograms of copper sulphate, 2.25 kilograms of stone lime, to 190 liters of water, take 1.8 kilograms of copper sulphate and dissolve in 95 liters of water, slake 2.25 kilograms of stone lime, and add water to make 95 liters. Mix the two as before indicated.

The two solutions may be mixed by pouring the dilute solution of copper sulphate into a strong solution of lime and then thoroughly mixing the two and making them up to 190 liters.

BURGUNDY MIXTURE

This preparation may be used in place of the Bordeaux mixture, if it is impossible to obtain good stone lime. Burgundy mixture will not color the foliage and fruit to such a great extent

as the Bordeaux mixture. The results obtained with this spray are about on a par with Bordeaux mixture.

Materials.

Copper sulphate (blue vitriol), kilos	1.4
Sodium carbonate (salsoda), kilos	1.65
Water, liters	190

PREPARATION

1. Dissolve each chemical separately in 95 liters of water.
2. Mix by pouring the two solutions into a third container as in making Bordeaux mixture.
3. Apply with a good pressure spray pump as soon as the solution is prepared.

SODA BORDEAUX MIXTURE

It may be impossible in certain sections to obtain good stone lime. If this be the case, soda Bordeaux mixture can be used. Soda Bordeaux mixture will not color the foliage and fruit to such an extent as the Bordeaux mixture. The soda Bordeaux mixture is more expensive and should be used only in cases where it is impossible to prepare the real Bordeaux.

Materials.

Copper sulphate (blue vitriol), kilos	1.8
Commercial caustic soda (sodium hydroxide), kilos	.6 to 1
Water, liters	190

APPARATUS

The same as that used in the preparation of Bordeaux mixture.

PREPARATION

1. Dissolve 1.8 kilograms of copper sulphate in hot water, place in half-barrel, and add water to make 95 liters.
2. Dissolve the caustic soda in the proportion of 0.6 kilogram to 4 liters of water.
3. Gradually pour the caustic soda solution into the copper sulphate solution, stirring continuously, until the solution becomes alkaline. The exact amount of caustic soda to use cannot be given because of the great variation in strength of the commercial product. The alkalinity of the solution can be determined by dipping a piece of red litmus into the solution. The red litmus will turn blue when the mixture is alkaline.
4. Add enough water to make 190 liters and stir vigorously.
5. Strain the mixture into a spray tank and apply as indicated under Bordeaux mixture.

AMMONIACAL SOLUTION OF COPPER CARBONATE

In cases where it is desirable to prevent staining the foliage or fruit of plants, the ammoniacal solution of copper carbonate is recommended.

Materials.

Concentrated ammonia (26° Baumé), liters	1.5
Copper carbonate, grams	168
Water to make, liters	190

APPARATUS

- One 190-liter mixing barrel.
- Two or more wooden pails.
- One strong paddle, about 2 meters long.
- One pair of hand scales.
- One strainer, of cloth.

PREPARATION

1. Measure 1.5 liters of concentrated ammonia into a wooden bucket and dilute to 10 liters.
2. Add to this 168 grams of copper carbonate and stir until all is in solution.
3. Dilute this stock solution to 190 liters before spraying.
4. Strain the mixture into a spray tank and apply as directed under Bordeaux mixture.

Never use metal vessels in the preparation of this mixture. Use only wooden or earthenware utensils. The spraying apparatus should be thoroughly rinsed after spraying.

RESIN-SALSODA STICKER

In spraying during the rainy season especially on those plants the foliage of which has waxy surfaces, it is highly desirable to add a sticker to the spray mixtures.

Materials.

Resin, kilo	0.9
Salsoda (sodium carbonate), kilo	0.45
Water, liters	3.8

APPARATUS

- A kerosene tin or similar utensil for boiling the solution.
- A paddle.
- A pair of hand scales.

PREPARATION

1. Dissolve 0.45 kilogram salsoda in 3.8 liters of water and boil.
2. Add 0.9 kilogram of powdered resin and continue boiling, until all is dissolved and the contents are a clear brown. Care should be taken that the mixture does not boil over.

For a medium adhesive add 1.9 liters of this sticker to 190 liters of the spray.

SULPHUR

For the control of powdery mildews and other superficially growing fungi, flowers of sulphur, or sulphur flour, may be used to the best advantage.

The sulphur is dusted on affected plants, preferably when the plants are wet with dew or rain.

LIME-SULPHUR SPRAY

In spraying operations it is often highly desirable to employ a spray that will control sucking insects and fungi at the same time. The lime-sulphur spray should be used under these circumstances. Very tender foliaged plants will not withstand this highly concentrated spray mixture.

Materials.

Stone lime, kilos	16.2
Flowers of sulphur, kilos	36
Water to make, liters	190

APPARATUS

- An open kettle large enough to hold 190 liters.
- A strong paddle.
- A pair of hand scales.
- A cloth strainer.

PREPARATION

1. Slake the lime in a convenient amount of water, adding the sifted sulphur and stirring vigorously during the process.
2. Make up to 190 liters with water.
3. Boil for one hour, adding water as necessary to prevent evaporation below 190 liters.
4. Stir from time to time.
5. Strain off the clear liquid into a spray tank, dilute and spray in the usual manner as discussed under Bordeaux mixture.
6. Storage. Concentrated lime-sulphur solutions keep well when stored in tight, filled, stoppered barrels, at the ordinary temperature.

The solution prepared in this manner is reddish brown and is too concentrated for direct application. It must be diluted with water at the rate of 1 liter of the concentrate to from 10 to 20 liters of water, according to the strength of the solution. For most accurate dilutions it is best to consult dilution tables after determining the specific gravity of the concentrate.

A commercially prepared lime-sulphur solution may be obtained on the market. This solution should be used as directed. It is much more expensive than the home-boiled preparation.

SELF-BOILED LIME-SULPHUR SPRAY

Some tender-foliaged plants cannot withstand the toxic effects of the copper sprays or the concentrated lime-sulphur spray. For these cases the self-boiled lime-sulphur spray will have to be employed.

Materials.

Stone lime, kilos	14.4
Flowers of sulphur, kilos	14.4
Water to make, liters	760

In this preparation four times the usual formula is used, because it has been found that these quantities give more satisfaction and convenient conditions for cooking than when smaller or greater amounts are used. When smaller amounts are desired, fractions of this formula may be used.

APPARATUS

- One strong 190-liter barrel.
- One strong paddle, about 2 meters long.
- One sifter (flour sifter).
- Two or more buckets.
- One pair hand scales.
- One strainer, of cloth.

PREPARATION

1. Weigh out 14.4 kilograms each of lime and sulphur, having first sifted the sulphur.
2. Place lime in barrel and add about 15 liters of water.
3. Add sulphur as soon as the lime begins to slake vigorously.
4. Stir preparation vigorously with the paddle, adding enough water from time to time to avoid "burning," and still not enough to "drown" the lime.
5. Add at least 95 liters of cold water with vigorous stirring as soon as the lumps of lime are thoroughly slaked. It is very necessary to cool the preparation at this time by adding the water as indicated.
6. Make up to 760 liters in spray tank, or dilute fractions of the stock solution correspondingly.
7. Strain before putting into spray tank by running the solution through a cloth strainer. Work through any lumps of sulphur with a small paddle.
8. Apply the spray with any good pressure spray pump.

FORMALIN SPRAY

This spray is only used for special purposes, such as spraying badly diseased citrus trees in order to defoliate them of all leaves attacked by citrus canker and to help kill sucking insects.

PREPARATION

A solution of formalin should be prepared that contains between 0.4 and 0.5 per cent of formaldehyde.

This percentage of formalin may be used in combination with the standard Bordeaux mixture, using the latter mixture as a diluting agent.

FORMALIN

A diluted solution of formalin is used for disinfection of seeds, vegetative reproductive parts, and soil.

Materials. Nonpoisonous to animals.

Formaldehyde (40 per cent), also called formalin, liter	0.5
Water, liters	150

The above is the usual formula for formalin. The amount of water used varies with the use to which the solution is put and with the length of treatment. Use as directed in special cases.

CORROSIVE SUBLIMATE

Corrosive sublimate is a strong disinfectant that is used for treatment of seeds or of vegetative reproductive parts and the disinfection of agricultural implements used in the eradication of diseased plants. Corrosive sublimate is a deadly poison to man and animals and should be labeled poison. Plants treated with this solution should not be used for human food or be fed to animals.

Materials. Deadly poisonous to animals.

Corrosive sublimate crystals, grams	112
Water, liters	114

PREPARATION

Dissolve the corrosive sublimate in from 2 to 4 liters of hot water and dilute this strong solution with water to make 114 liters.

Seeds treated should be thoroughly washed after applying the preparation and planted at once.

SPRAYING APPARATUS

For spraying operations conducted on a small scale a bucket pump or a knapsack pump will serve the purpose (Plate XXII, figs. 1, 2, and 3). Pumps of this character cost from 7 to 10 pesos for bucket pumps and from 20 to 40 pesos for knapsack pumps. Where extensive spraying operations are undertaken it will be necessary to employ a good pressure barrel pump (Plate XXII, fig. 4). The latter spraying outfit does the work more efficiently and in less time. The cost varies from 45 to 100 pesos, including hose and nozzle.

A good nozzle is essential in order to obtain the best results. Such a nozzle will produce a fine mist and cover the plant evenly over the portion sprayed. There are many spray outfits on the market. In purchasing a particular outfit, one should be selected which is simple, with accessible parts, and one which will produce a good pressure and a fine even mist of spray.

ACKNOWLEDGMENT

I am deeply indebted to Professor C. F. Baker for access to recent new publications of his collections, for checking up various

fungi, and for valuable suggestions; to Dr. H. S. Yates for his assistance in checking up various fungi; to Dr. Otto Schöbl for cultures of *Bacillus coli* (Escherich); to the Bureau of Agriculture for valuable assistance in obtaining coconut bud rot and abacá heart rot material; to the following among my students for preparing drawings: D. S. Baybay, D. Divinigracia, F. P. Lago, S. Marquez, G. S. Posadas, G. M. Reyes, J. L. Reyes, F. B. Santos, F. Serrano, G. G. Yap; to the following students for aiding with inoculation work: F. D. Luistro, G. O. Ocfemia, and T. I. Vista; and to Mr. L. B. Uichanco for his help in connection with some of the photographic development.

INDEX TO NAMES OF PLANTS AND OF PLANT DISEASES

- Abacá, 221.
 Acerbia maydis Rehm., 253.
 Acknowledgments, 262.
 Aeginetia indica Linnaeus, 237.
 Aithaloderma longisetum Sydow, 201.
 Ammoniacal solution of copper carbonate, 258.
 Ananas comosus (Linn.) Merr., 172.
 sativus Schultes f., 172.
 Andropogon schoenanthus Linn., 238.
 sorghum Linn., 173.
 Angular leaf spot, 208.
 Annona muricata Linn., 175.
 Annona squamosa Linn., 207.
 Anthostomella arecae Rehm., 177.
 cocoina Syd., 197.
 Apiospora camptospora Fenz. et Sacc., 240.
 Apium graveolens Linn., 175.
 Arachis hypogaea Linn., 176.
 Areca catechu Linn., 177.
 Artocarpus communis Forst., 178.
 incisa Linn. f., 178.
 integra (Raderm.) Merr., 178.
 integrifolia Linn. f., 178.
 Aschersonia sclerotoides Henn., 192.
 Aspergillus delacroixii Sacc. et Syd., 245.
 periconioides Sacc., 184.
 Asterinella stuhlmanni (Henn.) Theiss., 172.
 Asteroma phaseoli Brun., 231.
 Bacillus carotovorus Jones, 233.
 coli (Escherich), 195, 263.
 phytophthorus Appel, 243.
 prodigiosus (Ehrenb.) Fluegge, 214.
 solanacearum Erw. Smith, 181, 217, 222,
 241, 242.
 Bacterial blight, 222, 229.
 bud rot, 192.
 heart rot, 221.
 leaf stripe, 225.
 soft rot, 233.
 stem rot, 220, 240.
 wilt., 181, 217, 222, 241, 242.
 Bacterium malvacearum Erw. Smith, 208.
 Bakerophoma sacchari Diedicke, 234.
 Banana, 220.
 Bark rot, 184.
 Beans, 229.
 Beta vulgaris Linn., 179.
 Betel palm, 177.
 pepper, 231.
 Blackleg, or potato stem rot, 243.
 Black mildew, 204.
 rot, 179.
 rot of fruits, 209.
 rot of pods, 244.
 Blast of kernels, 249.
 Blight, 201, 205, 214, 229, 233, 243, 247.
 Botryodiplodia anceps Sacc. et Syd., 220.
 Botryosphaeria minuscula Sacc., 246.
 Bracket fungi, 212.
 Brassica oleracea Linn., 179.
 pekinensis (Lour.) Skeels, 180.
 Breadfruit, 178.
 Broomella zeae Rehm., 253.
 Bud rot of coconut, 195.
 Bunga, 177.
 Burgundy mixture, 257.
 Cabbage, 179.
 Cacao, 244.
 Caesalpinia sappan Linn., 207.
 Calabaza, 202.
 Calamismis, 232.
 Calonectria perpusilla Sacc., 227.
 Camoting cahoy, 219.
 Canavalia ensiformis DC., 181.
 gladiata DC., 181.
 Canker, 185, 210, 245.
 Capnodium footii Berk. et Desmaz., 197.
 Capsicum annuum Linn., 181.
 frutescens Linn., 181.
 spp., 207.
 Carica papaya Linn., 182, 207.
 Carrot, 203.
 Cassava, 219.
 Ceara rubber, 219.
 Celery, 175.
 Cercospora, 178, 179, 180, 202, 203, 204, 218,
 225, 227, 230, 234, 241, 248.
 apii Fries, 175.
 armoraciae Sacc., 180.
 artocarpus Sydow, 178.
 brassicicola P. Hennings, 180.
 canavaliae Syd., 181.
 henningsii Allesch., 219.
 lussoniense Sacc., 230.
 mangiferae Koorders, 218.
 manihotis P. Hennings, 219.
 nicotianae Ell. et Ev., 224, 225.
 pachyderma Sydow, 203.
 sesami A. Zimmerman, 240.
 stizobii Syd., 220.
 ubi Racib., 203.
 Chaetosphaeria eximia Sacc., 197.
 Chard, 179.
 Chlorosis, 223.
 nonparasitic, 186.
 Chromosporium crustaceum sp. n., 214.
 Citrus, 191.
 decumana (Linn.), 185.
 hystrix DC., 185.
 japonica Thunb., 185.
 maxima (Burn.) Merr., 185, 188, 191, 207.
 medica Linn., 185, 191.
 mitis Blanco, 185.
 nobilis Lour., 185, 186, 188, 191.
 (rough lemon), 185.
 spp., 184.
 (Kusaie lime), 185.
 (small orange), 185.
 (Washington navel), 185.
 Cladosporium herbarum (Pers.) Lk., 231.
 Clasterosporium maydicum Sacc., 253.
 punctiforme Sacc., 227.
 Coconut, 192.
 Cocos nucifera Linn., 192.

- Coffea arabica* Linn., 199, 200, 201, 207, 255.
excelsa Cheval., 199.
liberica, 200, 225.
robusta, 200, 255.
 spp., 198.
 Coffee, 198.
Colletotrichum arecae Syd., 177.
gloeosporioides Penzig, 192.
lussoniense Sacc., 219.
papayae (Henn.) Syd., 184.
Colocasia antiquorum (Schott), 201.
esculentum Schott, 201.
Coniosporium dendriticum Sacc., 198.
extremorum Syd., 240.
oryzinum Sacc., 228.
sorghii Sacc., 175.
vinosum (B. et. C.) Sacc., 240.
Coniothyrium coffeae Henn., 201.
 Control of plant diseases, 253.
Coprinus fimbriatus B. et Br., 197.
friesii var. *obscurus* Pat., 198.
 Corn, 249.
 Corrosive sublimate, 262.
Corticium salmonicolor, B. et Br., 190.
 Cotton, 208.
 Cowpeas, 247.
 Crop rotation, 253.
 Cucumbers, 202.
Cucumis sativus Linn., 202.
Cucurbita maxima Duch., 202.
 Cultural methods, 254.
 Curing and fermenting troubles, 223.
 Curly top, 247.
Cycloderma depressum Pat., 178.
Cyphella holstii Henn., 246.
Cytospora aberrans Sacc., 188.
palmicola B. et C., 198.
 Damping off, 182, 187, 198, 218.
 of seedlings, 224.
Daucus carota Linn., 203.
Diaporthe citrincola Rehm., 188.
Dichotomella areolata Sacc., 179.
Dictyophora phalloidea Desvaux, 236.
Didymella caricae Tassi., 184.
lussoniense Sacc., 204.
Didymium squamulosum (Alb. et Schw.) Fr., 181.
Didymosphaeria anisomera Sacc., 175.
 Die-back, 188, 246.
Dioscorea esculenta (Lour.) Burkill, 208, 204.
Diplodia ananassae Sacc., 178.
arecina Sacc., 177.
artocarpae Sacc., 178.
artocarpina Sacc., 179.
aurantii Catt., 188.
caricae Sacc., 184.
cococarpa Sacc., 198.
cococarpa var. *malaccensis* Tassi., 198.
erebra Sacc., 220.
epicocos Cooke, 197.
epicocos Cooke var. *minuscule* Sacc., 198.
lablab Sacc., 204.
manihoti Sacc., 219.
mori West., 220.
phaseolina Sacc., 231.
Diplodina degenerans Diedicke 242.
 Direct-heating method, 255.
 Disease-resistant varieties, 255.
Dolichos lablab Linn., 204.
uniflorus Lam., 204, 229.
 Downy mildew, 202, 203, 207, 249.
 Dry rot, 250.
 Dry sooty rot, 246.
 Early blight, 175.
 Egg plant, 241.
Elfvvingia tornata (Pers.) Murr., 178, 198.
Ellisiodothis rehmana Theiss. et Syd., 203.
Elsinoe canavaliae Rac., 181.
Endoxyla mangiferae Henn., 219.
Entyloma oryzae Syd., 228.
 Epiphytes, 188.
 Erysiphaceae, 171, 181, 183, 203, 218, 231, 241, 248.
Eugenia uniflora Linn., 207.
Eurotium candidum Speg., 214.
Eutypella citricola Speg., 188.
cocos Ferd. et Winge., 198.
heteracantha Sacc., 188.
heveae Yates, 214.
rehmana (Henn. et Nym.) v. Hohnel, 178.
Exosporium durum Saccardo, 196.
hypoxylodes Syd., 177.
pulchellum Sacc., 177.
 False smut or lump smut, 226.
Ficus carica Linn., 204.
 Fig, 204.
Fomes lignosus (Kl.) Bresadola, 212.
 Foot rot, 198.
 Formaldehyde, 261.
 Formalin, 261.
 disinfection, 256.
 spray, 261.
 Fruit blast, 220.
 rot, 178, 181, 182, 188, 189, 241.
Fumago vagans Pers., 175.
 Fungicides, 256.
 Fungi, other, 197, 214.
Fusarium, 182, 214, 224, 247, 249, 255.
heveae Henn., 184.
theobromae App. et Strunk 244, 245.
 Gabi, 201.
Ganoderma incrassatum (Berk.) Bres. var. *substipitata* Bres., 198.
 General discussion, 253.
Gloeoglossum glutinosum (Per.) Durant, 198.
Gloeosporium canavaliae Syd., 181.
catechu Syd., 177.
intermedium Sacc., 192.
macrophomoides Sacc., 208, 241.
melongenae Sacc., 241.
palmarum Oud., 177.
 Glume spot, 227.
Glycine hispida Max., 206.
max (Linn.) Merr. 204, 206, 207, 208.
Gossypium brasiliense Macfad., 209.
herbaceum Linn., 209.
 spp. 208.
 Grain mold, 178.
 Guanabano, 175.

- Guignardia arecae Sacc., 177.
 manihoti Sacc., 219.
 manihoti Sacc., var. diminuta Sacc., 219.
 Gummosis, 189.
 Haplographium chlorocephalum (Fres.)
 Grove, 227.
 Haplosporella melanconioides Sacc., 240.
 Helminthosporium, 227.
 caryopsidum Saccardo, 173.
 curvulum Sacc., 252.
 heveae Petch, 211.
 inconspicuum Cke. et Ell., 251, 252, 253.
 sesameum Sacc., 241.
 Hemileia, 200.
 vastatrix, B. et Br., 199, 200.
 Heterodera radicecola Greef et Müller, 225, 237.
 Hevea, 210.
 brasiliensis (HBK) Muell. et Arg., 209.
 Hibiscus sabdariffa Linn., 207, 214.
 Hormodendron cladosporioides (Fr.) Sacc.,
 197.
 Horse beans, 181.
 Hypoxylon atropurpureum Fr. (on coccids),
 188.
 Icmo, 231.
 Ipomoea batatas Poir, 215.
 Jack fruit, 178.
 Kaffirs, 173.
 Kernel Smut, 173.
 Kuehneola desmii (B. et Br.) Syd., 209.
 fici (Cast.) Butl. 204.
 fici (Cast.) Butl. var. moricola P. Hen-
 nings, 219.
 Lablab bean, 204.
 Lactuca sativa Linn., 216.
 Lasiodiplodia, 215.
 theobromae (Pat.) Griff. et Maubl. 182,
 188, 203, 215, 245, 246, 247.
 Leaf rot, 183.
 spot, 172, 173, 175, 176, 178, 179, 180, 196,
 199, 202, 203, 204, 211, 218, 219, 220,
 222, 227, 230, 233, 234, 235, 240, 241,
 242, 248, 249, 251.
 Lembosia bromeliacearum Rehm., 172.
 Lemons, 184, 185.
 Leptosphaeria (Leptosphaerella) oryzina
 Sacc., 227.
 orthogramma (B. et Br.) Sacc. 253.
 Leptothyrium circumscissum Sydow, 219.
 Lettuce, 216.
 Lichens, 189, 247.
 Limes, 184.
 Lime-sulphur spray, 260.
 Linga, 240.
 Lonchocarpus sp., 207.
 Loranthus philippensis Chamisso, 188.
 Lycopersicum esculentum Mill, 217.
 Macrophoma, 220.
 musae (Cke.) Berl. et Voglino 220, 222.
 Mangifera indica Linn., 218.
 Mango, 218.
 Mani, 176.
 Manihot dichotoma Ule., 219.
 utilissima Pohl, 219.
 Marasmius, 236.
 Marchalia constellata (B. et Br.) Sacc., 178.
 Massarina raimundoi Rehm., 188.
 Megalonectria pseudotrichia (Schw.) Speg.,
 210.
 Melanconium lineolatum Sacc., forma, 240.
 sacchari Massee, 235, 236.
 Meliola arundinis Pat., 240.
 mangiferae Earle, 219.
 Micropeltis, 192.
 mucosa Syd., 199.
 Milos, 173.
 Moraceae, 219.
 Morus alba Linn., 219.
 Mottled leaf: nonparasitic, 189.
 Mucuna deeringiana Merr. (Stizolobium de-
 eringiana Bort.), 220.
 Mulberry, 219.
 Musa sapientum Linn., 220.
 textilis Née, 221.
 Mycogone cervina Ditm. var. theobromae Sacc.,
 245.
 Mycosphaerella, 221.
 caricae Syd., 183.
 dioscoreicola Syd., 204.
 musae Speg., 220, 222.
 Myrothecium oryzae Sacc., 227.
 Nangka, 178.
 Nectria bainii Massee var. hypoleuca Sacc.,
 245.
 discophora Mont., 246.
 episphaeria (Tode.) ; Fr., 188.
 Nematodes, 225, 237.
 Nicotiana tabacum Linn., 207, 222.
 Oospora candidula Sacc., 245.
 oryzeturum Sacc., 228.
 perpusilla Sacc., 231.
 Ophiobolus oryzinus Sacc., 228.
 Ophionectria theobromae (Pat.) Duss, 246.
 Orange galls, 204, 232.
 Oranges, 184, 185.
 Oryza sativa Linn., 225.
 Pachyrrhizus erosus (Linn.) Urb., 229.
 Palawania cocos Syd., 197.
 Papaya, 182.
 Para rubber, 209.
 Passiflora quadrangularis Linn., 207.
 Pea, 231.
 Peanut, 176.
 Pechay, 180.
 Penicillium, 182, 189.
 maculans sp. n., 214.
 Peroneutypella arecae Syd., 178.
 cocoas Syd., 198.
 Peronospora, 207, 208.
 Pestalozzia funera Desm., 219.
 palmarum Cooke, 177.
 palmarum Cooke et Grev., 196, 197.
 pauciseta Sacc., 219.
 Phakospora pachyrhizi Syd., 229.
 Phaseolus calcaratus Roxb., 206, 207, 229, 230,
 231.
 lunatus Linn., 207, 231.
 mungo Linn., 231.
 spp., 229.
 vulgaris Linn., 207, 229, 231.
 Pheleostroma hypoxylodes Syd., 178.

- Phoma baderiana* Sacc., 248.
herbarum Westd., 219.
oleracea Sacc., 203.
sabdariffae Sacc., 214.
sesamina Sacc., 241.
solanophila Oud., 242.
Phomopsis arecae Syd., 177.
capsici (Magnaghi) Sacc., 181.
dioscoreae Sacc., 203.
palmicola (Wint.) Sacc., 177.
Phycomycetes, 171.
Phyllachora, 204, 219.
phaseolina Syd., 230.
sacchari P. Hennings, 235.
sacchari spontanei Syd., 235.
sorghii v. Höhnel, 178, 174.
Phyllactinia suffulta (Rebent.) Sacc., 219.
Phyllosticta citrella Stainton, 185.
Phyllosticta circumsepta Sacc., 189.
cocophylla Pass., 197.
glumarum Sacc., 227.
graffiana Sacc., 204.
insularum Sacc., 175.
manihotica Syd., 219.
miurai Miyake, 227.
Physalospora affinis Sacc., 245.
guignardioides Sacc., 181.
linearis Sacc., 253.
Physiological trouble, 211.
Phytophthora, 182, 202, 211, 246, 249.
colocasiae Rac., 201, 202.
faberi Maubl., 182, 209, 210, 244, 245.
infestans (Mont.) de Bary, 243.
nicotianae Breda de Haan, 224, 255.
Pineapple, 172.
Pink disease, 190.
Piper betle Linn., 231.
Pisum sativum Linn., 231.
Plant sanitation, 253.
Plasmopara cubensis (B. et C.) Humphrey, 202.
Picaria bananincola Rehm., 220.
Pod spot, 248.
Pomelos, 184.
Potato, 242.
Powdery mildew, 181, 183, 218, 219, 231, 241, 248.
Premna cumingiana Schau, 171.
Pseudomonas campestris (Pammel.) Erw. Smith, 179.
Pseudomonas citri Hasse, 185.
Pseudomonas phaseoli Erw. Smith, 229.
Psophocarpus tetragonolobus DC., 204, 232.
Puccinia kuehnii (Krueg.) Butl., 237.
Puccinia purpurea Cooke, 174, 175.
Pythium, 182.
Pythium debaryanum Hesse, 182, 218, 224, 225.
Radish, 233.
Raphanus sativus Linn., 233.
Reana luxurians Dur., 250.
Red pepper, 181.
Resin-salsoda sticker, 259.
Rhizoctonia, 182, 187, 198, 203, 205, 206, 218, 224, 227, 228, 229, 233, 247, 255.
Rhizopus, 178, 182, 203, 215.
artocarpi Rac. 178.
Rice, 225.
Rind disease, 235.
Root disease, 212, 236.
galls, 225, 237.
parasite, 237.
Rot, 177.
Roselle, 214.
Rosellinia cocoes Henn., 198.
Rust, 174, 199, 203, 204, 208, 209, 219, 229, 231, 237, 249.
Saccharum officinarum Linn., 207, 233, 235.
spontaneum Linn., 235, 239.
Saprophytic fungi, 213.
Sarcinella raimundoi Sacc., 242.
Scaly bark, 191.
Sclerospora javanica Palm., 249.
maydis (Rac.) Butler, 249, 250.
Sclerotium, 177, 187, 198, 224, 228, 229, 255.
Self-boiled lime-sulphur spray, 260.
Septogloeum arachidis Rac., 176.
Septoria lablabina Sacc., 204.
lablabis Henn., 204.
miyakei Sacc., 227.
Sereh disease, 237, 238.
Sesame, 246.
Sesamum indicum Linn., 240.
Sincamas, 229.
Smut, 239, 252.
Soda bordeaux mixture, 258.
Soil sterilization, 255.
Soja, 204.
Solanum melongena Linn., 241.
tuberosum Linn. 242.
Sooty mold, 172, 175, 191, 197, 201, 231, 240.
Sordaria oryzae Sacc., 228.
Sorghums, 173.
Sorghum vulgare Pers., 173.
Soursop, 175.
Soy bean, 204.
Spegazzinia ornata Sacc., 228.
Spiny mold: imperfect fungus, 191.
Sporodesmium bakeri Syd., 220.
Spotting of prepared plantation rubber, 213.
Spraying apparatus, 262.
Squash, 202.
Standard Bordeaux mixture, 257.
Steirochaete ananassae Sacc., 173.
lussoniensis Sacc., 219.
Stem disease, 201.
rot, 203, 227, 228.
rot: bacterial, 240.
Sterile fungus, 250.
Sterility of nuts, 197.
Storage rots, 203, 215.
Straight, or sterile, head, 228.
Sugar cane, 233.
Sulphur, 259.
Sweet potato, 215.
Sword beans, 181.
Tamarindus indica Linn., 207.
Theobroma cacao Linn., 244.
Tipburn, 216.

- Tobacco, 222.
 Tomato, 217.
 Traversoa dothiorelloides Sacc. et Syd., 219.
 Trichoderma koningi (Oud.) Oud. et Koning, 214.
 Trotteria venturioides Sacc., 204.
 Trybliediella mindanaensis Henn., 188, 214.
 rufula (Spreng.) Sacc., 188.
 Twig fungi, 219.
 Uncinula, 171.
 Uredo dioscoreae (Berk. et Brm.) Petch, 203.
 dioscoreae-alatae Rac., 203.
 vignae Bres., 249.
 Uromyces appendiculatus (Pers.) Link, 231.
 mucunae Rabh., 220.
 sojae Syd., 208.
 Ustilaginoidea virens (Cke.) Takahashi, 226.
 Ustilago sacchari Rabenhorst, 239.
 sorghii (Lk.) Passarini, 173.
 zeae (Beckm.) Unger, 252.
 Valsaria citri Rehm., 188.
 insitiva (de Not.) Ces. et de Not., 220.
 Velvet bean, 220.
 Vermicularia capsici Syd., 181.
 horridula Sacc., 204.
 sesamina Sacc., 241.
 xanthosomatis Sacc., 249.
 Vigna catjang Walp., 248.
 sinensis Endl., 248.
 spp., 247.
 Voandzeia subterranea Thou., 205, 206, 207.
 Winged bean, 232.
 Wither tip, 192.
 Woroninella dolichi (Cke.) Syd., 204.
 psophocarpi Rac., 232.
 Xanthosoma sagittifolium Schott, 202, 249.
 Yams, 203.
 Zea mays Linn., 207, 249.
 Zignoella nobilis Rehm., 188.
 Zygosporium oscheoides Mont., 177.

ILLUSTRATIONS

PLATE I

- FIG. 1. Leaf spot of sorghum caused by *Phyllachora sorghi* v. Höhnel.
2. Rust of sorghum caused by *Puccinia purpurea* Cooke.
3. Kernel smut of sorghum caused by *Ustilago sorghi* (Lk.) Pass.

PLATE II

- FIG. 1. Leaf spot of pechay caused by *Cercospora brassicicola* Henn.
2. Leaf spot of pechay caused by *Cercospora brassicicola* Henn.
3. Leaf spot of chard caused by *Cercospora*.

PLATE III

- FIG. 1. Mottled leaf of *Citrus*.
2. Citrus canker on leaves of *Citrus*.
3. Citrus canker. On leaves of *Citrus maxima* (Burm.) Merr. (*Citrus decumana* Linn.), showing spread of the disease by a leaf miner, which is the larva of the moth *Phyllocnistis citrella* Stainton.

PLATE IV

- FIG. 1. Citrus canker. Stem canker on *Citrus*.
2. Citrus canker. Fruit and stem of *Citrus*.
3. Citrus canker. Fruit of *Citrus maxima* (Burm.) Merr. (*C. decumana* Linn.).

PLATE V

- FIG. 1. Coconut bud rot. Old infection. Entire central group of leaves killed and some fallen over.
2. Coconut bud rot. Central leaves killed and some fallen over. Outer older leaves healthy.
3. Coconut bud rot. Diseased central bud fallen over.

PLATE VI

- FIG. 1. Coconut bud rot. Young infection, showing unfolded tips of leaves just starting with the attack. From this point the disease advances downward into the growing point and more woody portion.
2. Coconut bud rot. Old infection. Entire cabbage and growing point softened.
3. Coconut bud rot. Old infection. Rotted portion just above growing point.
4. Coconut bud rot. Old infection. Characteristic brownish stripe, showing limits of infection in the wood.
5. Coconut but rot. Inoculated seedling, showing diseased portion. Three days after inoculation.
6. Coconut bud rot. Typical case of infection produced in seedling three days after inoculating with a pure culture of bacteria isolated from a bud rot tree. Entire growing point and surrounding tissue rotted.

PLATE VII

- FIG. 1. Coconut bud rot. Young infection. Bacteria entered in young leaves at top. Note brownish line of demarcation at bottom and sides of farthest advance of the disease toward the base.
2. Coconut bud rot. Young infection starting in at young unfolded leaves at top.
3. Coconut bud rot. Portion just below growing point in cabbage and young wood. Young infection.

PLATE VIII

- FIG. 1. Sterility of coconut fruit.
2. False smut, or lump smut, of rice caused by *Ustilaginoidea virens* (Cke.) Tak.
3. Leaf spot of coconut caused by *Pestalozzia palmarum* Cke. et Grev.
4. Leaf spot of coconut caused by *Exosporium durum* Sacc.
5. Leaf spot of rice caused by *Cercospora*.

PLATE IX

- FIG. 1. Blight of beans, caused by *Rhizoctonia*. Note sclerotial bodies of fungus on stems of plant.
2. Blight of beans, caused by *Rhizoctonia*. Note sclerotial bodies of fungus on stems of plant.
3. Blight of beans, *Phaseolus calcaratus* Roxb., caused by *Rhizoctonia*.

PLATE X

- FIG. 1. Blight produced on various seedlings inoculated with a pure culture of *Rhizoctonia* isolated from soy bean.
2. Black rot of cabbage caused by *Pseudomonas campestris* (Pammel.) Erw. Smith. Note blackening of vascular bundles and bundle scars, also rot at base of stem.
3. *Rhizoctonia*. Sclerotial bodies. *a*, from pure culture of fungus-producing blight of soy bean; *b*, from blighted soy bean plant.

PLATE XI

- FIG. 1. Heart rot of abacá.
2. Leaf spot of banana caused by *Mycosphaerella musae* Speg.

PLATE XII

- FIG. 1. Bacterial wilt of tobacco caused by *Bacillus solanacearum* Erw. Smith. Soil in foreground has been planted with tobacco for two successive years. It is heavily infested with the bacteria. The majority of plants have been killed.
2. Bacterial wilt of tobacco caused by *Bacillus solanacearum* Erw. Smith.
3. Leaf spot of tobacco caused by *Cercospora nicotianae* Ell. et Ev.
4. Root galls of tobacco caused by nematodes, *Heterodera radiculicola* Greef et Müller.

PLATE XIII

- FIG. 1. Damping off of coffee seedlings caused by *Rhizoctonia*.
- FIGS. 2 and 3. Damping off of tobacco caused by *Phytophthora nicotianae* Breda de Haan. Inoculated and control seed flats.

PLATE XIV

- FIG. 1. Sooty mold of pineapple.
2. Bacterial blight of *Phaseolus vulgaris* Linn. caused by *Pseudomonas phaseoli* Erw. Smith.
3. Rust of mulberry caused by *Kuehneola fici* (Cast.) Butl. var. *moricola* Henn.

PLATE XV

- FIG. 1. Blight of gabi caused by *Phytophthora colocasiae* Rac.
2. Orange galls of calamismis caused by *Woroninella psophocarp* Rac.

PLATE XVI

- FIG. 1. Blight of sugar cane caused by *Rhizoctonia*. Note sclerotial bodies.
2. Leaf spot of sugar cane caused by *Cercospora*.
3. Rust of sugar cane caused by *Puccinia kuehnii* (Krueg.) Butl.
4. Leaf spot of sugar cane caused by *Bakerophoma sacchari* Diedicke.

PLATE XVII

- FIG. 1. Smut of sugar cane caused by *Ustilago sacchari* Rabh.
2. Rind disease of sugar cane caused by *Melanconium sacchari* Massee.
3. The same as fig. 2.

PLATE XVIII

- FIG. 1. Leaf spot of eggplant caused by *Gloeosporium melongenae* Sacc.
2. Fruit rot of red pepper caused by *Vermicularia capsici* Syd.
3. Fruit rot of eggplant caused by *Gloeosporium melongenae* Sacc.

PLATE XIX

- FIG. 1. Dry rot of cacao pods caused by *Nectria bainii* Massee var. *hypoleuca* Sacc.
2. Dry rot of cacao pods caused by *Lasiodiplodia theobromae* (Pat.) Griff. et Maubl.
3. Dry rot of cacao pods caused by *Fusarium theobromae* App. et Strunk.
4. Storage rot of sweet potato caused by *Lasiodiplodia theobromae* (Pat.) Griff. et Maubl.
5. Black rot of cacao pod caused by *Phytophthora faberi* Maubl. Pod inoculated with pure culture.
6. Rot of male inflorescence of jack fruit caused by *Rhizopus artocarp* Rac.

PLATE XX

- FIG. 1. Leaf spot of corn caused by *Helminthosporium inconspicuum* C. et E.
2. Downy mildew of corn caused by *Sclerospora maydis* (Rac.) Butl.
3. Blast of corn kernels possibly caused by *Fusarium*.

PLATE XXI

- FIG. 1. Soil sterilizer. Direct-heating method.
2. Preparation of standard Bordeaux mixture. Mixing lime and copper sulphate solutions.

PLATE XXII

- FIG. 1. Knapsack spray pump.
 2. Knapsack spray pump.
 3. Bucket spray pump.
 4. Barrel spray pump.

TEXT FIGURES

- FIG. 1. *Phyllachora sorghi* v. Höhnel. Cross section of stroma, showing perithecium, ostiolum, asci, and ascospores ($\times 75$). Vascular bundles of leaf develop normally within the mass of fungus mycelium.
2. *Phyllachora sorghi* v. Höhnel. *a*, asci with paraphyses ($\times 325$); *b*, ascospores ($\times 325$).
3. *Puccinia purpurea* Cooke. *a*, teleutospores ($\times 315$); *b*, uredospores ($\times 315$).
4. *Septogloeum arachidis* Rac. *a*, cushionlike structure of conidiophores ($\times 350$); *b*, germinating conidia ($\times 350$); *c*, conidia ($\times 350$).
5. *Septogloeum arachidis* Rac. Germinating conidia ($\times 350$); germ tubes entering host tissue by way of stomata.
6. *Rhizopus artocarpus* Rac. *a*, sporangium with spores ($\times 330$); *b*, rhizoid ($\times 330$), from tissue of fruit; *c*, bursted sporangium, showing columella, sporangiophore, and spores ($\times 330$).
7. *Cercospora brassicicola* Henn. *a*, group of conidiophores ($\times 340$); *b*, small conidia germinating ($\times 340$); *c*, typical needlelike conidia ($\times 340$).
8. *Mycosphaerella caricae* Syd. *a*, perithecium ($\times 325$); *b*, broken perithecium, showing production of asci ($\times 325$); *c*, ascus with ascospores ($\times 325$); *d*, ascospores ($\times 325$).
9. *Meliola*. On *Citrus nobilis* Lour. *a*, perithecium ($\times 75$); *b*, ascus ($\times 310$); *c*, ascospores ($\times 310$); *d*, mycelium with hyphopodia ($\times 310$); *e*, setae ($\times 75$).
10. Bud rot of coconut. *a*, cross section of infected portion of young unfolded leaf, showing mass of bacteria in tissue ($\times 425$); *b*, cross section of infected portion of young unfolded leaf, showing mass of bacteria in xylem tubes of a vascular bundle ($\times 330$).
11. *Pestalozzia palmarum* Cke. et Grev. Conidia, showing characteristic appendages ($\times 990$); from pure culture.
12. *Micropeltis mucosa* Syd. Immature perithecium ($\times 335$). The fungus does not penetrate leaf tissue.
13. *Micropeltis mucosa* Syd. Asci with ascospores ($\times 340$).
14. *Hemileia vastatrix* B. et Br. *a*, infected coffee leaf, showing mycelium in tissue and production of uredospores some of which were cut in sectioning ($\times 325$); *b*, teleutospores ($\times 325$); *c*, germinating teleutospores, promycelia, and sporidia ($\times 325$); *d*, uredospores ($\times 325$).
15. *Phytophthora colocasiae* Rac. Conidia ($\times 330$).
16. *Rhizoctonia*. Mycelium from pure culture of fungus ($\times 340$), isolated from *Glycine max* (Linn.) Merr. (*G. hispida* Maxim.). Note characteristic branching.

17. *Rhizoctonia*. Mycelium from sclerotial body, growing in pure culture ($\times 340$); *a*, formation of sclerotial body; *b*, portions of sclerotial body. Isolated from *Glycine max* (Linn.) Merr. (*G. hispida* Maxim.).
18. *Peronospora*. On *Glycine max* (Linn.) Merr. (*G. hispida* Maxim.). *a*, portion of typical branched conidiophore ($\times 320$); *b*, conidia ($\times 320$).
19. *Uromyces sojæ* Syd. Uredospores ($\times 315$).
20. *Lasioidiplodia theobromæ* (Pat.) Griff. et Maubl. Section through diseased sweet potato, showing pycnidium, ostiolum, paraphyses, and immature spores ($\times 270$).
21. *Bacillus solanacearum* Erw. Smith. Cross section of tomato stem, showing xylem tubes completely filled with bacteria ($\times 350$).
22. Section through diseased abacá leaf, in heart of plant, showing mass of bacteria in tissue ($\times 330$).
23. *Phytophthora nicotianæ* Breda de Haan. Section of damped-off stem of tobacco, showing mycelium penetrating throughout the tissue ($\times 310$).
24. *Cercospora nicotianæ* Ell. et Ev. *a*, group of conidiophores, two of which are germinating ($\times 340$); *b*, germinating conidia ($\times 340$).
25. *Ustilago imoidea virens* (Cke.) Tak. *a*, spores ($\times 1,800$); *b*, germinating spores ($\times 1,800$).
26. *Cercospora lussoniensis* Sacc. from *Phaseolus lunatus* Linn. *a*, group of conidiophores ($\times 340$); *b*, germinating conidia ($\times 340$).
27. *Woroninella psophocarpi* Rac. *a*, cross section of gall from leaf, showing production of sporangia ($\times 80$); *b*, sporangia ($\times 325$); *c*, zoöspores ($\times 325$).
28. *Bakerophoma sacchari* Diedicke. Various types of conidia ($\times 1,000$).
29. *Cercospora* on *Saccharum officinarum* Linn. *a*, group of conidiophores ($\times 320$); *b*, conidia ($\times 320$); *c*, conidia ($\times 640$).
30. *Melanconium sacchari* Masee. *a*, mass of conidia, composing hairlike strand ($\times 300$); *b*, conidia ($\times 900$).
31. *Puccinia kuehnii* (Krueg.) Butl. *a*, uredospores ($\times 320$); *b*, germinating uredospores ($\times 320$).
32. *Ustilago sacchari* Rabh. *a*, spores ($\times 340$); *b*, germinating spores with promycelia ($\times 340$); *c*, sporidia ($\times 340$).
33. *Phytophthora faberi* Maubl. *a*, chlamydospores ($\times 325$) from pure culture; *b*, conidium ($\times 325$) from pure culture; *c*, conidia ($\times 325$) from surface of diseased fruit.
34. *Fusarium theobromæ* App. et Strunk. *a*, portion of conidiophore ($\times 315$); *b*, microconidia ($\times 315$); *c*, macroconidia ($\times 315$).
35. *Nectria bainii* Masee. var. *hypoleuca* Sacc. *a*, asci with ascospores ($\times 325$); *b*, ascospores ($\times 650$).
36. *Lasioidiplodia theobromæ* (Pat.) Griff. et Maubl. from cacao. *a*, young conidia ($\times 350$); *b*, germinating young conidia ($\times 350$); *c*, mature conidia ($\times 350$); *d*, germinating mature conidia ($\times 350$).

37. *Cercospora*. On *Vigna sinensis* Endl. *a*, group of conidiophores with immature conidia attached ($\times 350$); *b*, conidia ($\times 350$); *c*, germinating conidia ($\times 350$); *d*, germinating conidiophores ($\times 350$).
38. Erysiphaceae on *Vigna catjang* Walp. Mycelium and conidiophores with chains of conidia ($\times 325$).
39. *Sclerospora maydis* (Rac.) Butl. *a*, conidiophore with conidia, arising from stomata of leaf ($\times 320$); *b*, conidia ($\times 320$); *c*, germinating conidia ($\times 320$).
40. *Helminthosporium inconspicuum* C. et E. *a*, group of conidiophores ($\times 320$); *b*, conidium from tassel of corn ($\times 320$); *c*, conidia from leaf of corn ($\times 320$).
41. *Helminthosporium inconspicuum* C. et E. *a*, germinating conidiophores ($\times 320$); *b*, germinating conidia ($\times 320$).
42. *Helminthosporium inconspicuum* C. et E. Direct penetration of host tissue ($\times 325$).
43. *Helminthosporium inconspicuum* C. et E. Germinating spore ($\times 345$), germ tube about to enter stomata.

REINKING: DISEASES OF PLANTS.]

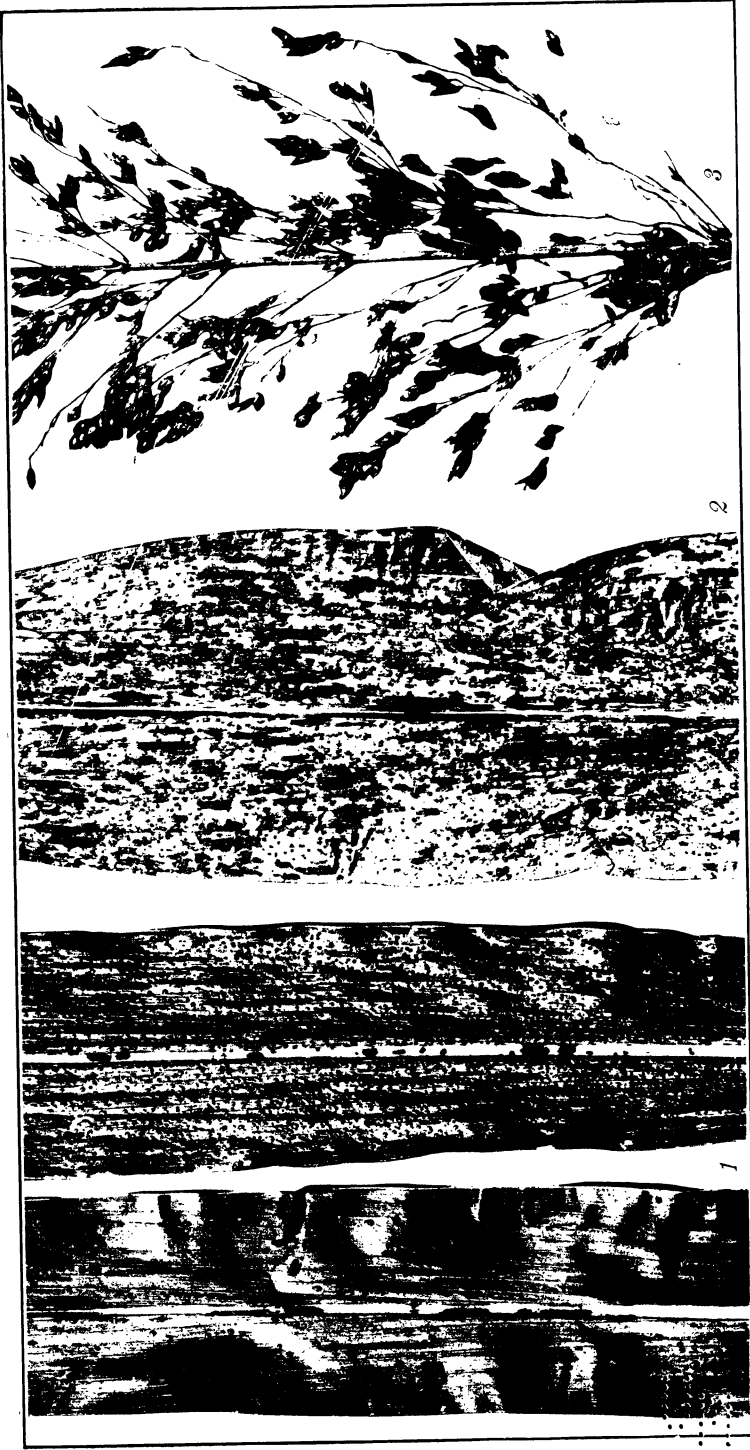

PLATE I. FUNGOUS DISEASES OF SORGHUM.

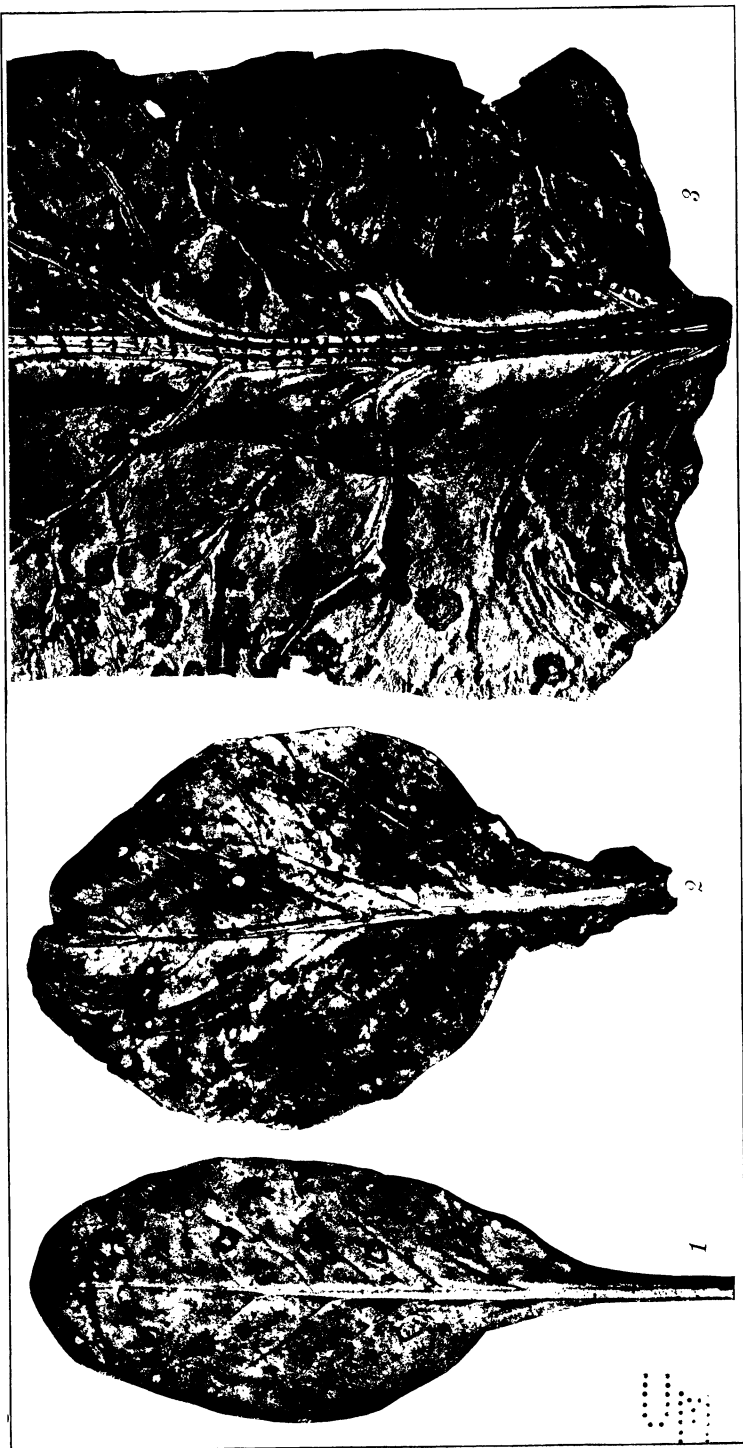

PLATE II. LEAF SPOT CAUSED BY FUNGUS.

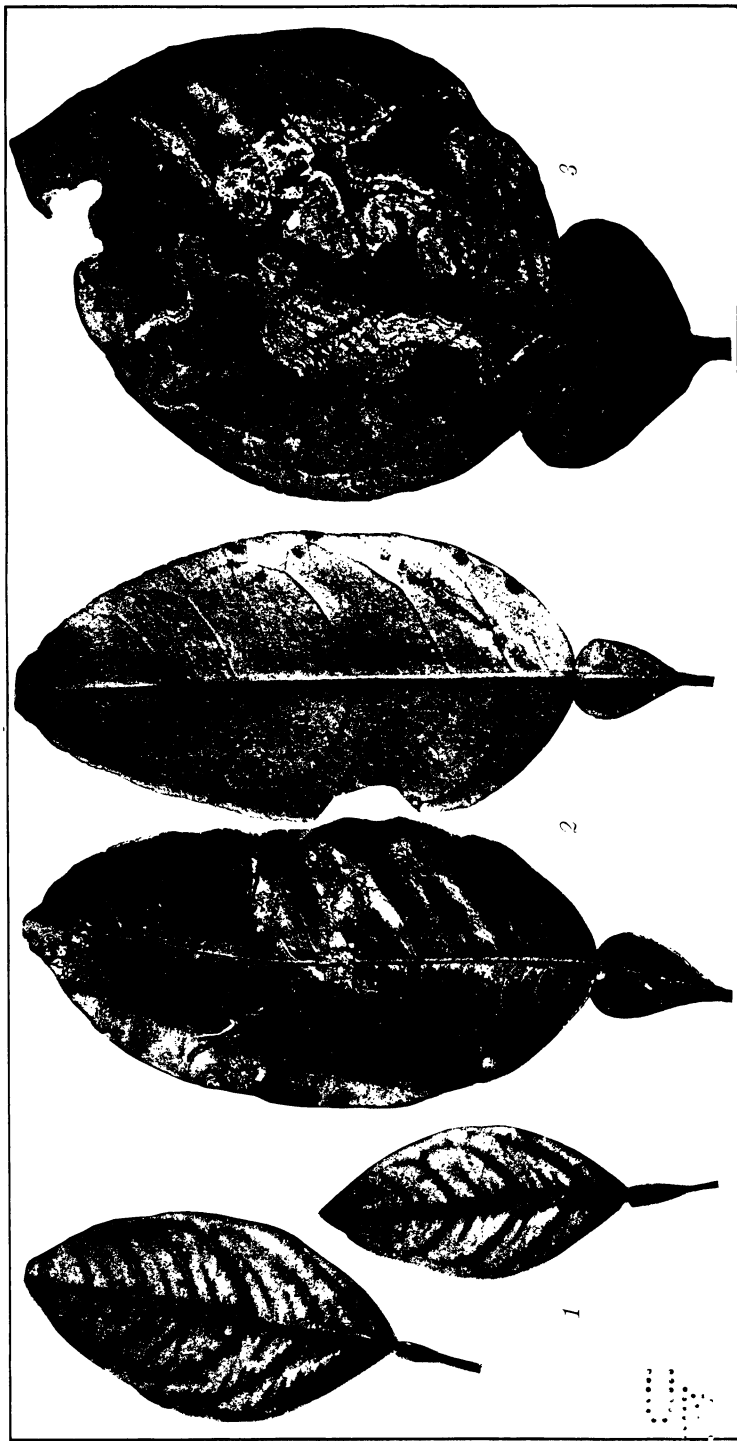

PLATE III. DISEASES OF CITRUS LEAVES.



PLATE IV. CITRUS CANKER.



Fig. 1.



Fig. 2.



Fig. 3.

PLATE V. COCONUT BUD ROT.

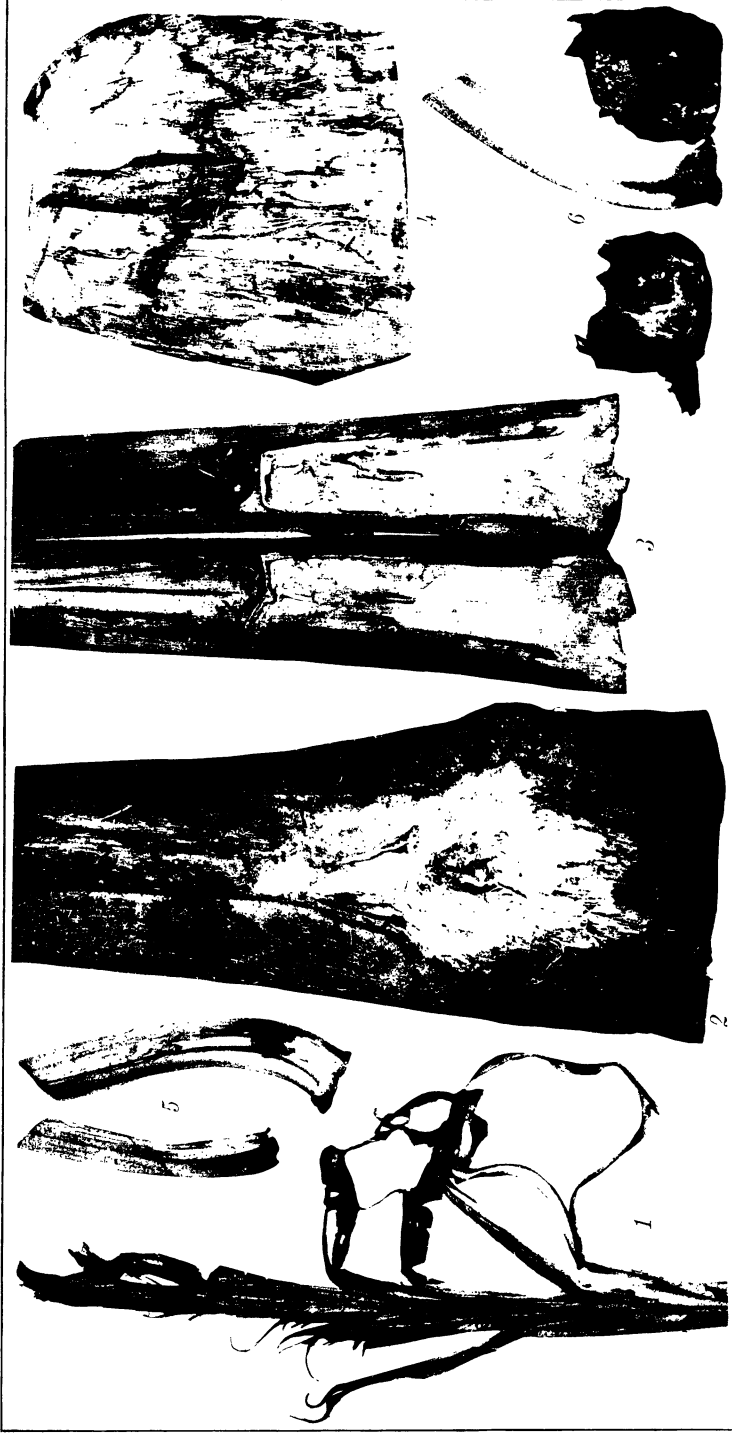

PLATE VI. COCONUT BUD ROT.



Fig. 1.



Fig. 2.



Fig. 3

PLATE VII. COCONUT BUD ROT.



PLATE VIII. DISEASES OF COCONUT AND RICE.



PLATE IX. RHIZOCTONIA BLIGHT OF BEANS.



PLATE X. BLACK ROT OF CABBAGE AND RHIZOCTONIA BLIGHT.

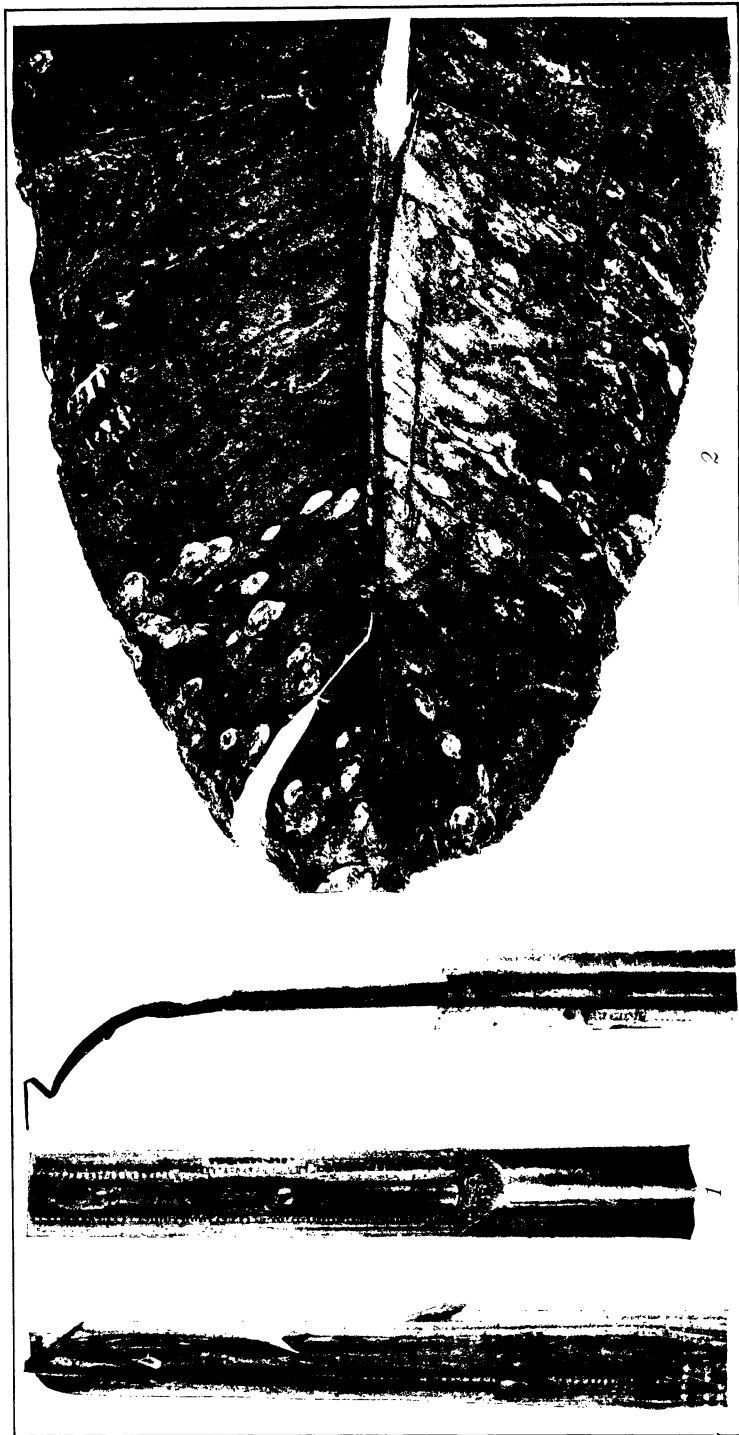

PLATE XI. HEART ROT OF ABACA AND LEAF SPOT OF BANANA.

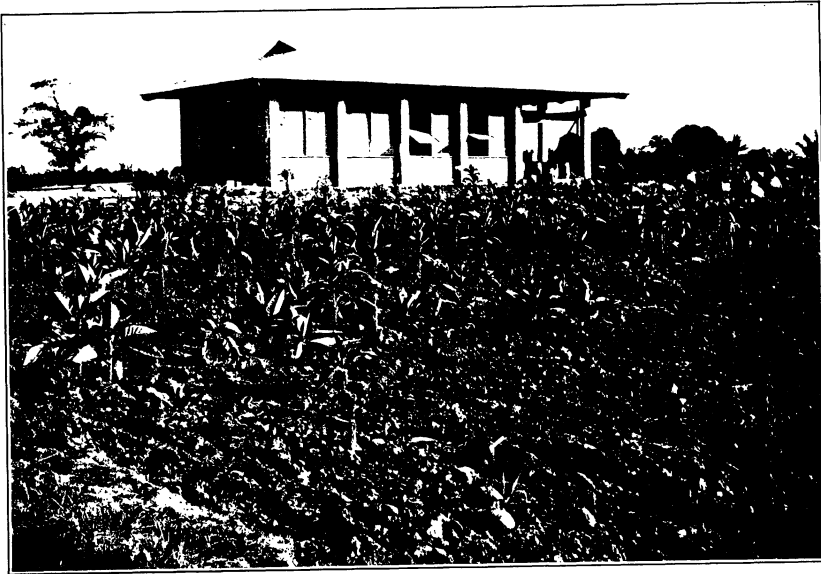
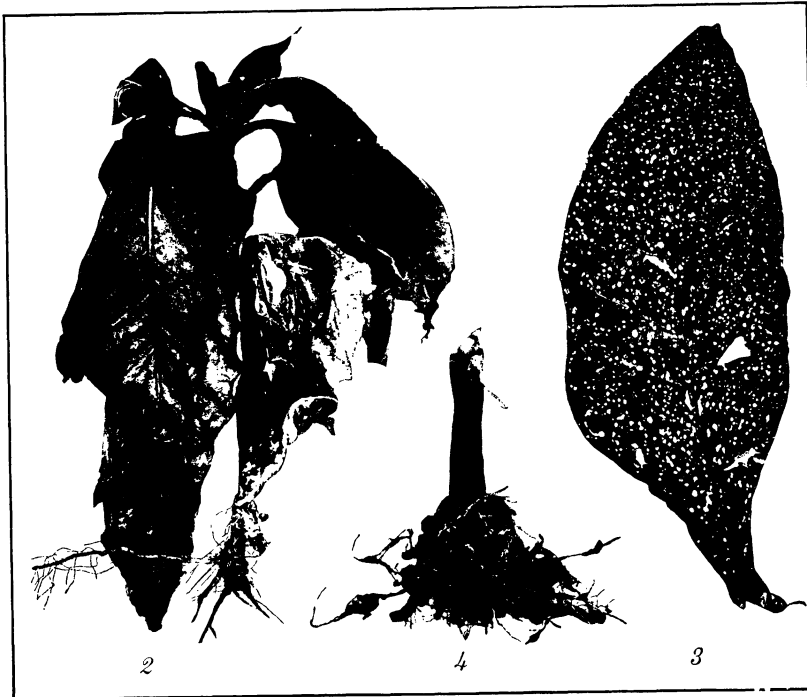

Fig. 1. Bacterial wilt of tobacco.



Figs. 2, 3, and 4. Diseases of tobacco.

PLATE XII.

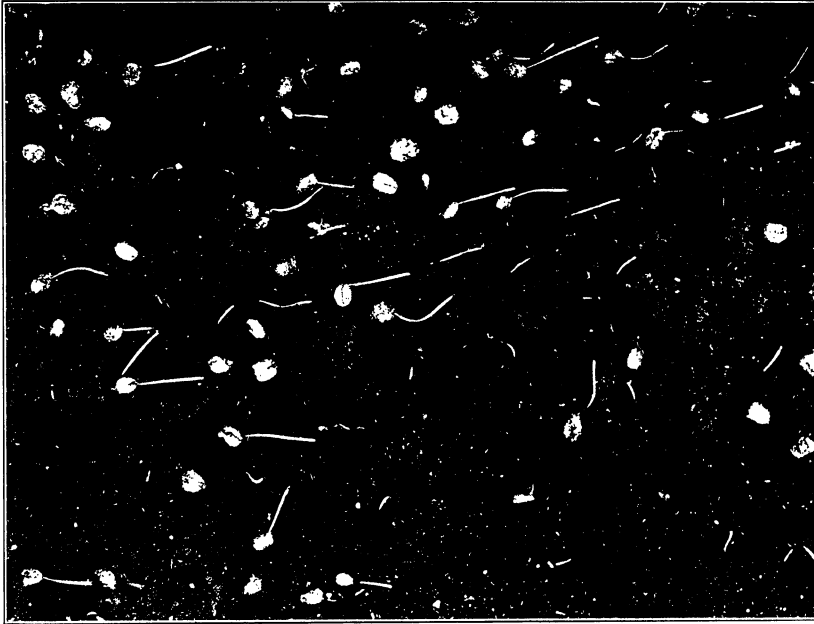

Fig. 1.

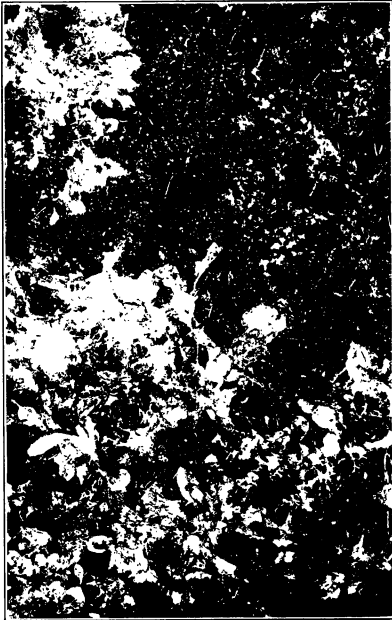

Fig. 2.

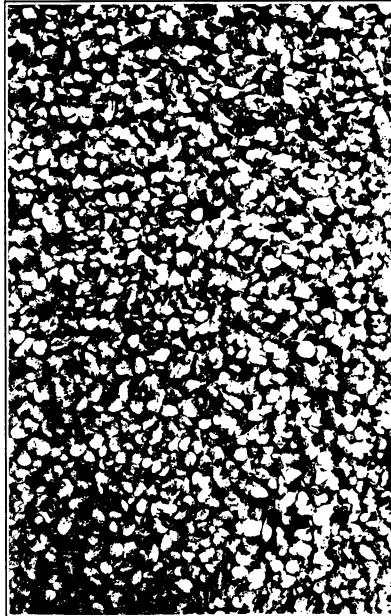

Fig. 3.

PLATE XIII. DAMPING-OFF OF COFFEE AND TOBACCO.

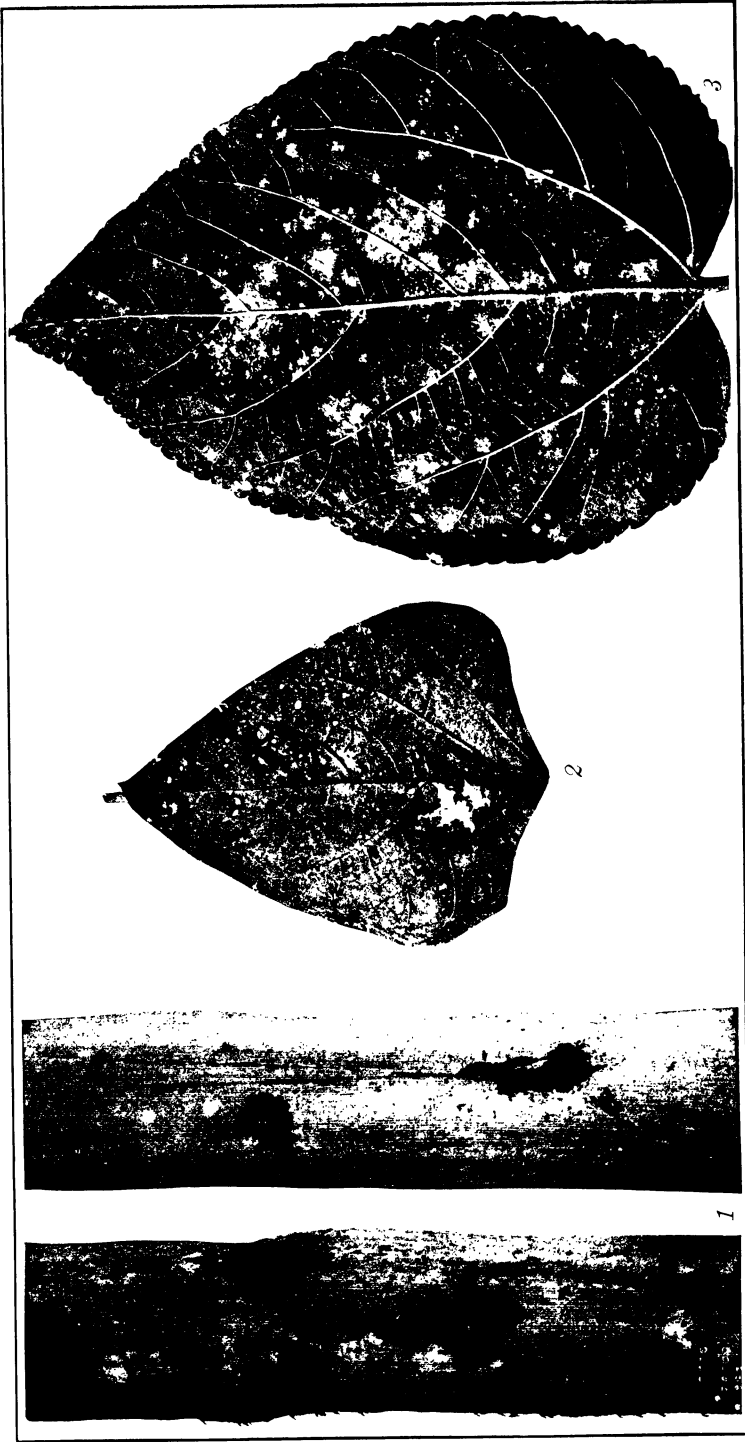

PLATE XIV. DISEASES OF PINEAPPLE, BEAN, AND MULBERRY.

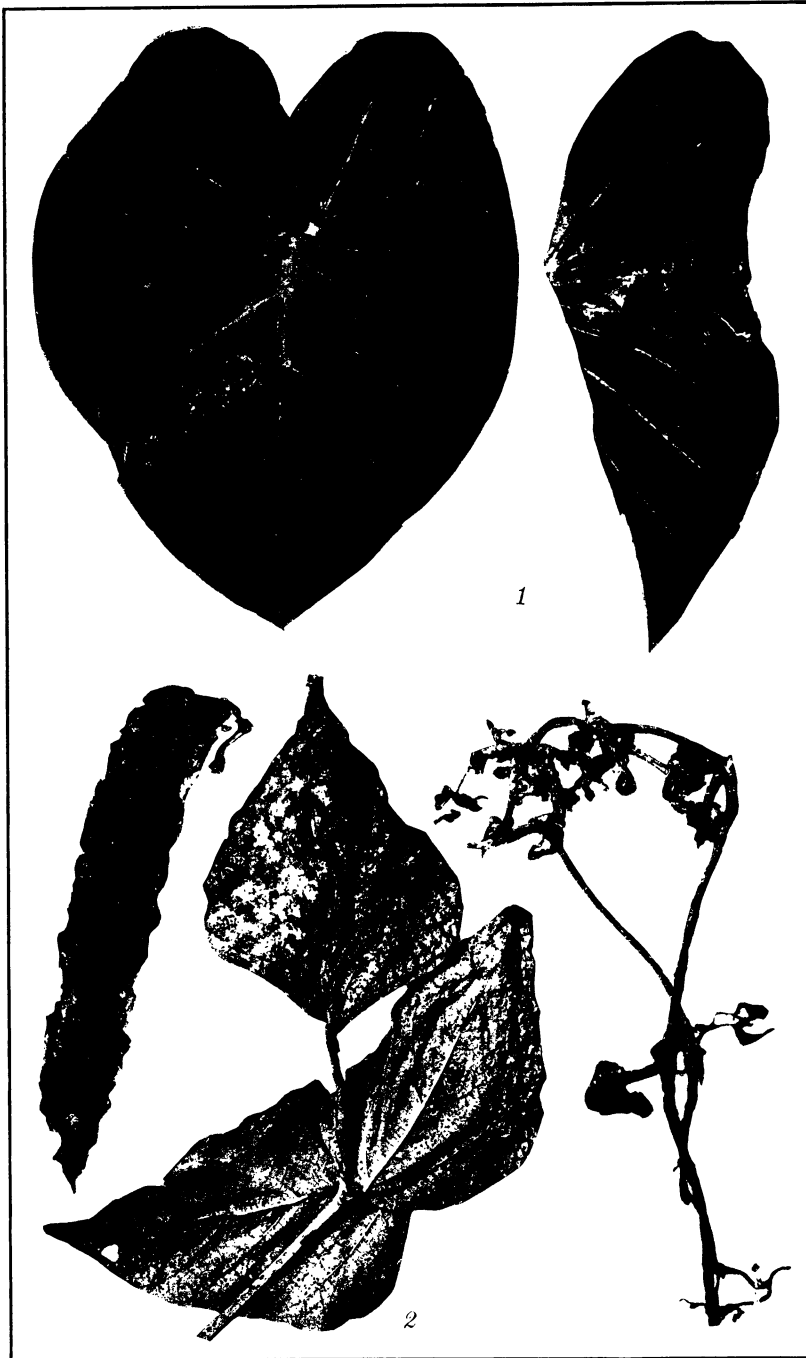

PLATE XV. BLIGHT OF GABI AND ORANGE GALLS OF CALAMISMIS.

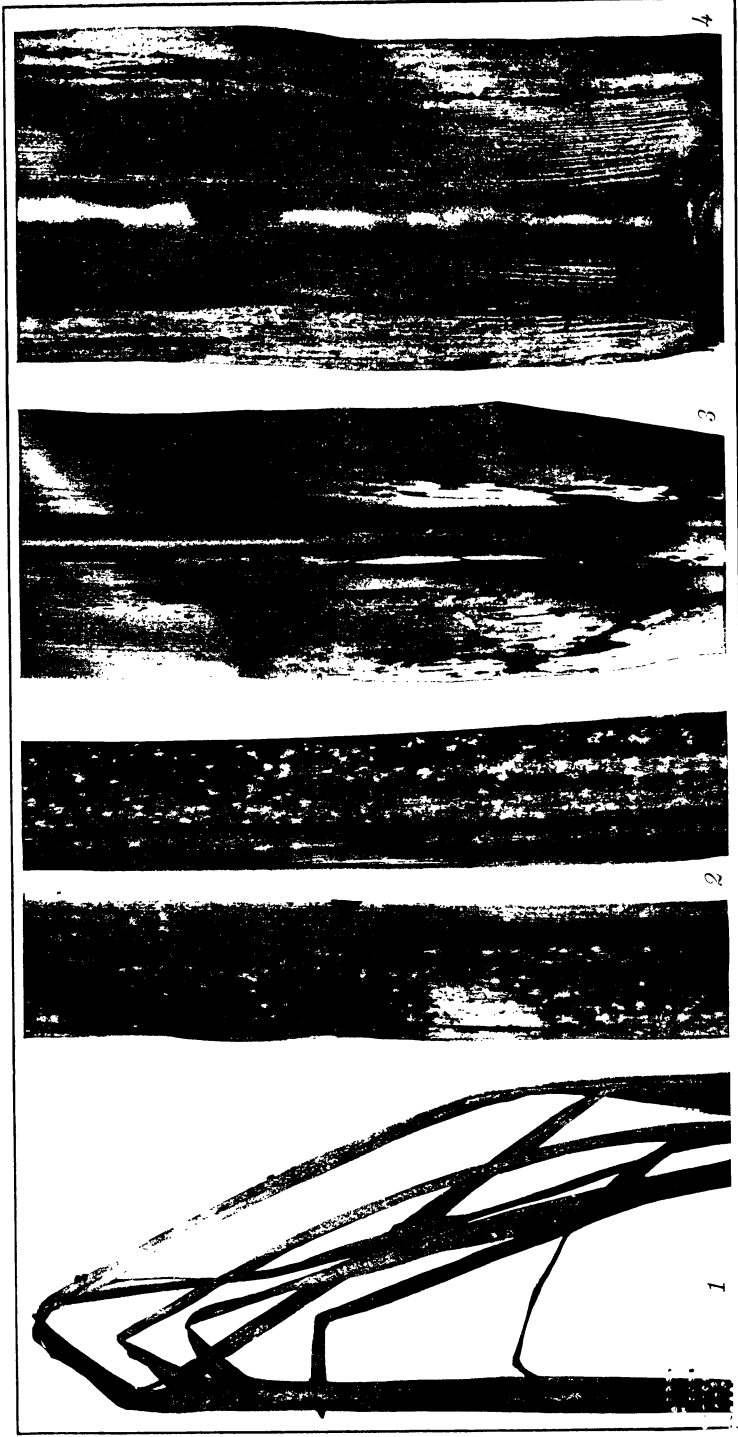

PLATE XVI. DISEASES OF SUGAR CANE.

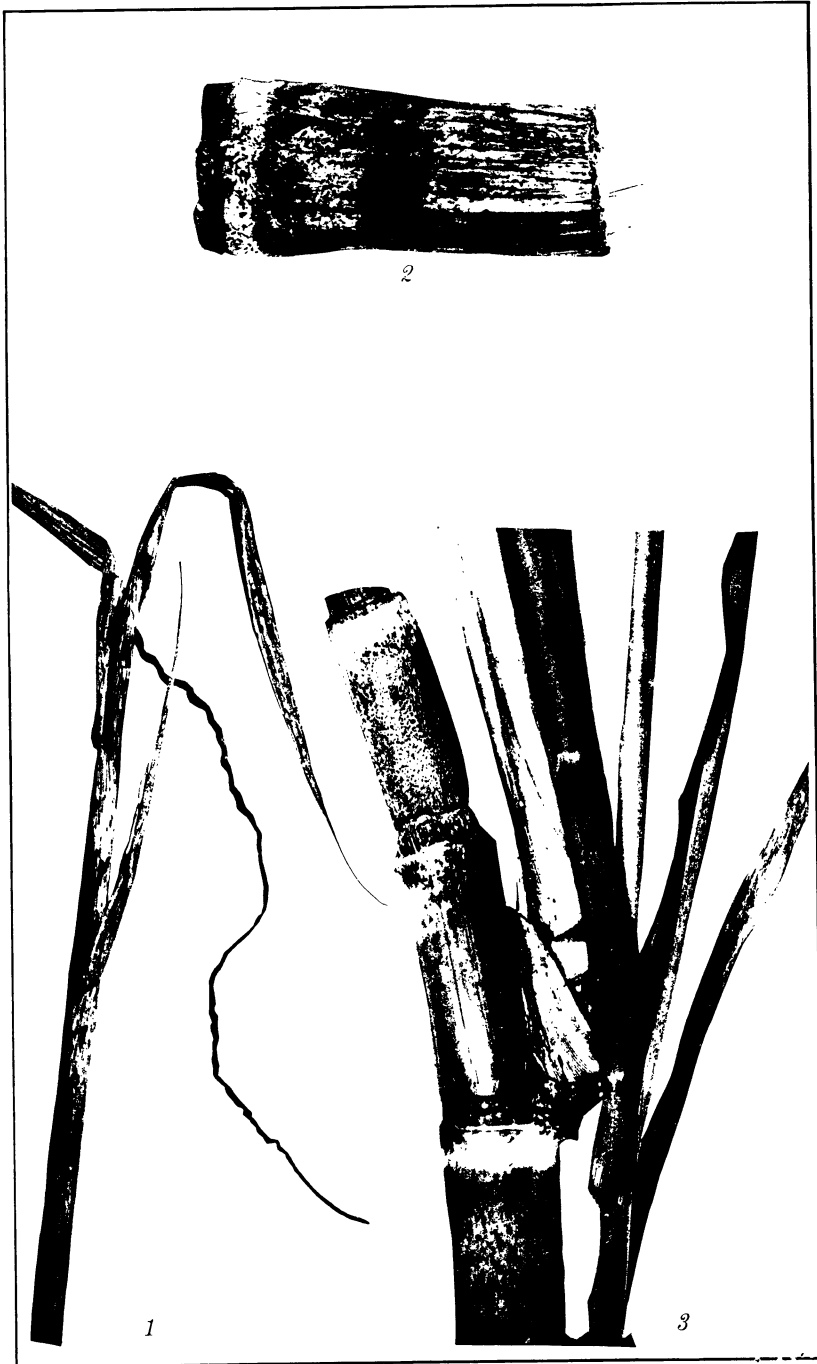

PLATE XVII. DISEASES OF SUGAR CANE.

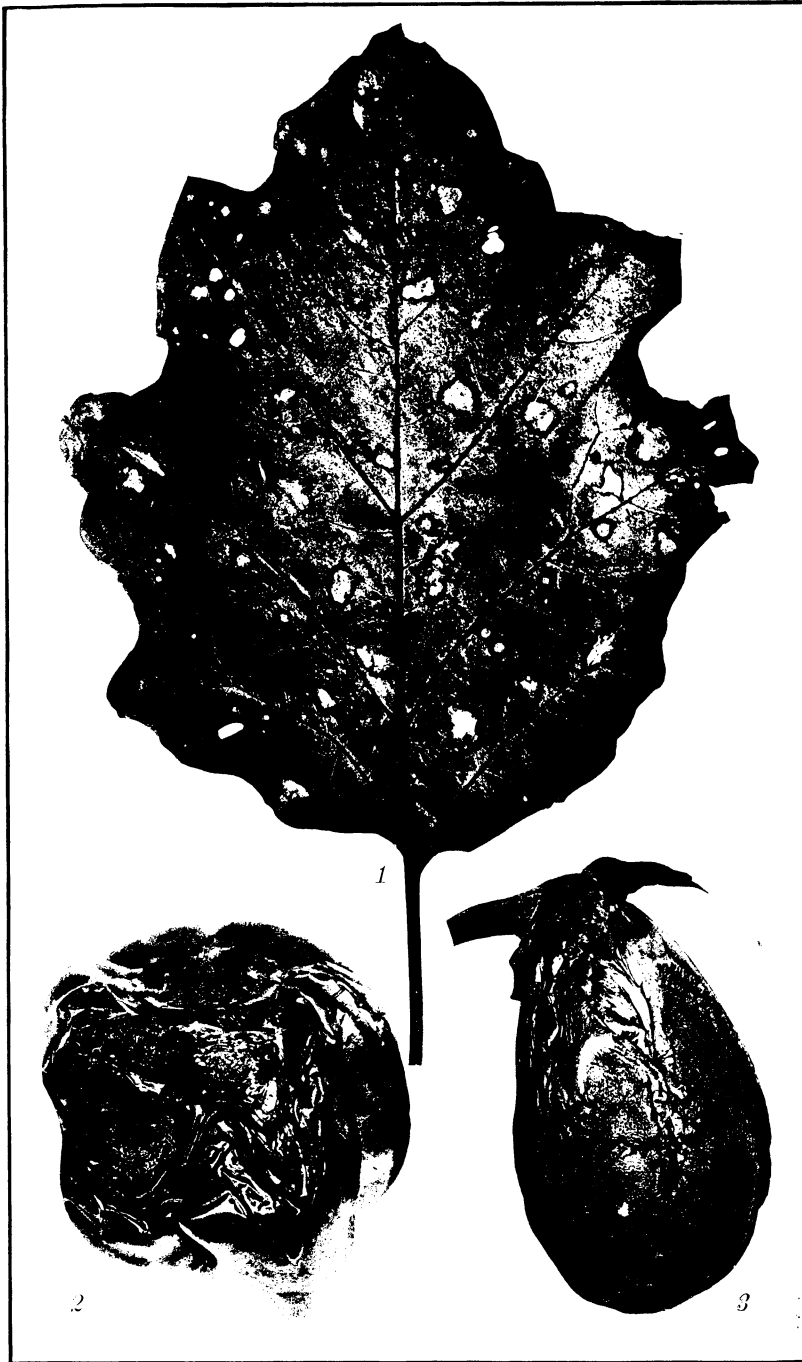

PLATE XVIII. DISEASES OF EGGPLANT AND PEPPER.

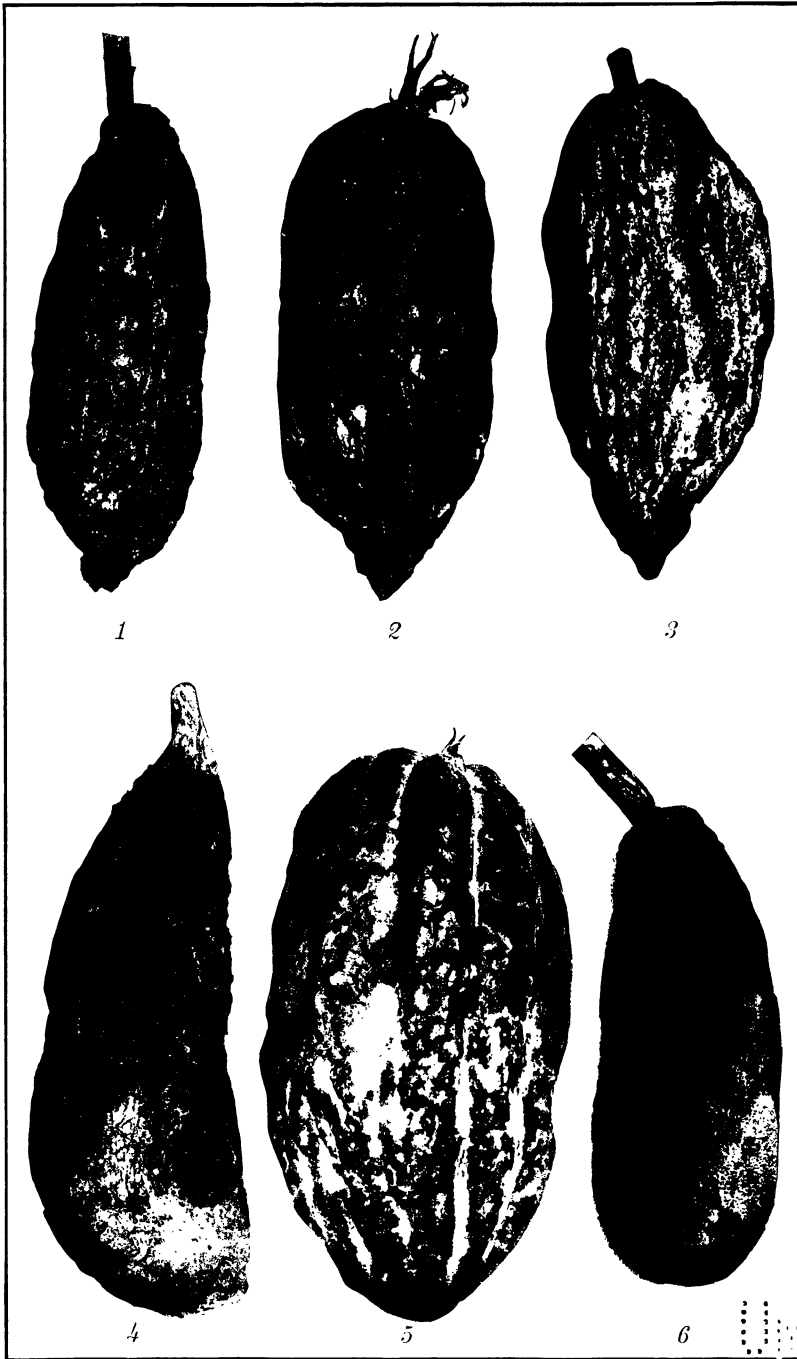

PLATE XIX. DISEASES OF CACAO, SWEET POTATO, AND JACK.



PLATE XX. DISEASES OF CORN.



Fig. 1. Soil sterilizer. Direct-heating method.

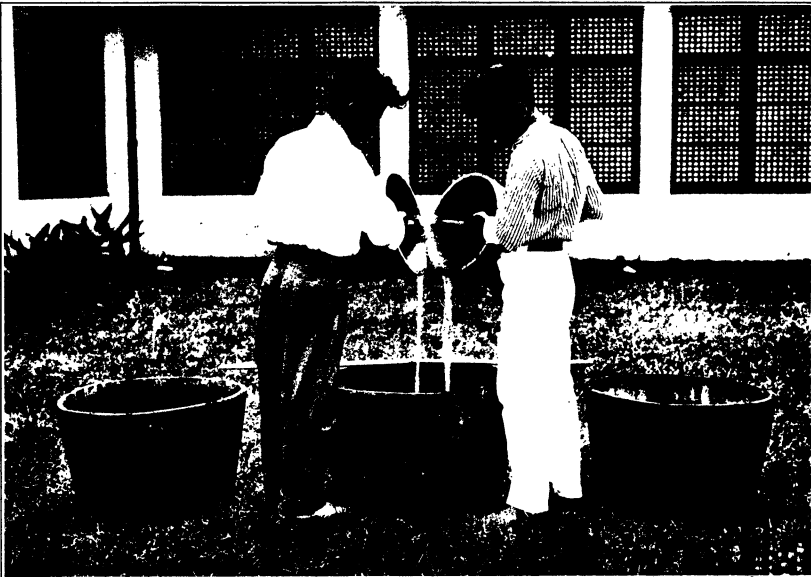

Fig. 2. Preparation of standard Bordeaux mixture.

PLATE XXI.

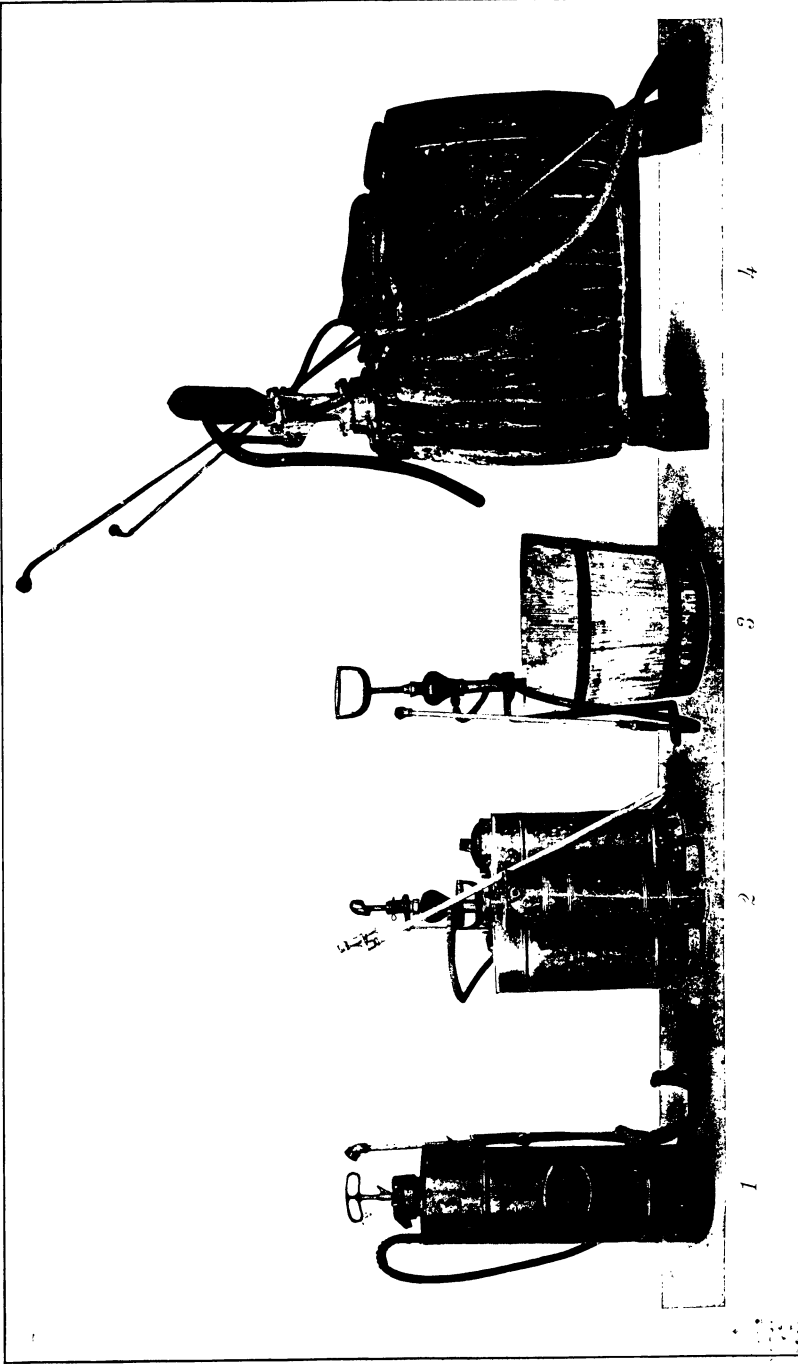

PLATE XXII. SPRAYING APPARATUS.

06.1
P 93
58

VOL. XIII, SEC. A, No. 6

NOVEMBER, 1918

THE PHILIPPINE
JOURNAL OF SCIENCE

ALVIN J. COX, M. A., PH. D.
GENERAL EDITOR

SECTION A
CHEMICAL AND GEOLOGICAL SCIENCES
AND THE INDUSTRIES

EDITED WITH THE COÖPERATION OF

H. C. BRILL, PH. D.; J. R. WRIGHT, PH. D.; G. W. HEISE, M. S.
T. DAR JUAN, A. B., PH. D.; A. H. WELLS, A. B.
R. C. MCGREGOR, A. B.; H. E. KUPFER, A. B.

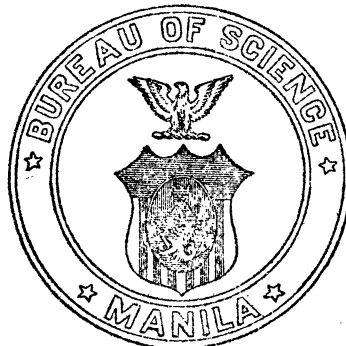

MANILA
BUREAU OF PRINTING
1918

PHILIPPINE JOURNAL OF SCIENCE

A TEN-YEAR INDEX

CONTENTS AND INDEX OF THE PHILIPPINE JOURNAL OF SCIENCE, VOLUME I (1906) TO VOLUME X (1915)

Order No. 449. Bureau of Science Publication No. 8. Paper, 441 pages.
Price \$2, United States currency, postpaid.

One copy of this index has been sent free of charge to each subscriber that has received Volumes XI and XII of the Journal.

This publication consists of:

The complete contents of the first ten volumes of the Philippine Journal of Science, all sections; giving all authors, titles of articles, and page numbers. The exact date of issue of each number is recorded.

An author index, being an alphabetical list of all the contributors. The titles of all the articles are listed under the names of their respective authors.

A subject index. The subject matter is very fully indexed by catch words from the titles, by geographical localities, and by subjects. All systematic names in zoölogy and botany, as well as the thousands of English and local names, are entered in the index.

STUDIES IN PHILIPPINE DIPTERA, II

By M. BEZZI

Order No. 437. Bureau of Science Publication No. 10. Paper, 59 pages and 1 plate.
Price \$0.50, United States currency, postpaid.

This is the second century of Professor Bezzi's enumeration of Philippine species of flies and includes descriptions of new genera and new species.

PLEASE GIVE ORDER NUMBER

Orders for Bureau of Science publications may be sent to the BUSINESS MANAGER, Philippine Journal of Science, Bureau of Science, Manila, P. I., or to any of the following agents:

AGENTS

THE MACMILLAN COMPANY, 64-66 Fifth Avenue, New York, U. S. A.
WM. WESLEY & SON, 28 Essex Street, Strand, London, W. C., England.
MARTINUS NIJHOFF, Lange Voorhout 9, The Hague, Holland.
KELLY & WALSH, Limited, 32 Raffles Place, Singapore, Straits Settlements.
A. M. & J. FERGUSON, 19 Baillie Street, Colombo, Ceylon.
THACKER, SPINK & Co., P. O. Box 54, Calcutta, India.

THE PHILIPPINE
JOURNAL OF SCIENCE

A. CHEMICAL AND GEOLOGICAL SCIENCES
AND THE INDUSTRIES

VOL. XIII

NOVEMBER, 1918

No. 6

MECHANICAL EXTRACTION OF COIR

By F. V. VALENCIA¹

(From the Bureau of Science, Manila)

ONE PLATE

A valuable industry new to the Philippines can be established in the extraction of fibers from coconut husks and in the use of these husk fibers for the manufacture of brushes, door mats, cordage, floor mats, mattresses, pillows, cushions, etc. The exploitation of such an industry would not only result in utilizing the husks but would at the same time tend to eliminate their use as fuel in the grill drying of copra and thus obviate an amount of smoke that produces a dark-colored copra of inferior grade. The ash is generally used for fertilizer, and rejected husks are frequently incinerated in large heaps for the manurial value of the ash. The coir industry in Ceylon is well established and gives household employment to many women and children. There are also mills equipped with modern machinery. The best-grade fiber is said to be made entirely by native methods which have been described by D. S. Pratt.²

Prudhomme³ says that in Ceylon one thousand husks yield an average of from 68 to 79 kilograms of fiber. These figures may be taken to represent the average commercial yield of fiber in India, Ceylon, Straits Settlements, Java, and Indo-China. Saleeby⁴ has estimated that the husks of one thousand coconuts

¹ Testing engineer.

² *This Journal*, Sec. A (1914), 9, 195.

³ Prudhomme, E., *Le Cocotier*. Augustin Challamel, Éditeur, Paris (1906), 374.

⁴ *Phil. Agr. Rev.* (1912), 5, 278.

will give an average yield of 75 kilograms of fiber, of which 65 kilograms are yarn fiber and 10 kilograms brush fiber. It has been estimated⁵ also that the husk of each nut gathered in the Philippines in 1916 would have yielded 0.1 kilogram (0.22 pound) of coir, and that in the same year there were harvested in the Philippines 735,000,000 coconuts. On the last two basic yields 55,025 and 73,500 metric tons, respectively, of total coconut fiber could have been extracted from the husks in the Philippine Islands in 1916.

Unquestionably one of the most important factors that has prevented the development of the coir industry in the Philippines is the large amount of manual labor required to extract a small quantity of fiber that has a comparatively low market price. It is doubtful if hand extraction in the Philippines will ever be largely developed. The fact that the coir industry flourishes in India and other tropical countries outside of the Philippines is largely due to very cheap labor. In those places the extraction of the fiber is largely practiced by women and children at home during their spare time. The establishment of a paying coir industry in the Philippines resolves itself into the installation of an efficient power-driven plant situated within easy reach of an adequate supply of cheap husks. In tropical countries outside the Philippines a great deal has been done in the design and manufacture of power-driven extracting, cleaning, and baling units, etc., for the extraction of coir on a large scale, in the hope of increasing the production, lowering the cost, and ultimately becoming independent of the slow hand methods. Machines of several types have been built, altered, experimented with, and offered to the public; yet much remains to be done to perfect the most successful ones. Hamel Smith and Pape⁶ have described some of these together with their operation. They say:

Fibre engineers, especially those working to perfect coir fibre machinery, are the first to agree that, although great improvements have been introduced during the last few years, perfection has not been reached, and so they are devoting their energies to further improve the appliances for treating coir fibre that have already been placed on the market. We are very interested in their efforts to do so, and believe that the scientific development of coco-nut estates, backed up by ample funds, and

⁵ Commerce Reports, Washington, D. C., Saturday, July 14, 1917, No. 163, pp. 164-165.

⁶ Hamel Smith, H., and Pape, F. A. G., *Coco-nuts: The Consols of the East*. "Tropical Life" Publishing Dept., London (1912), 250-462, describe these machines and their operation.

urged on by the necessity of dispensing with hand-labour in the factories on estates as far as possible, will encourage the coir-fibre engineers to further activity until finally, with the help of the estate owners, something entirely satisfactory to both sides will be evolved.

Meanwhile, we can truly state that during the last few years at least one firm of engineers with whom we have been working, have devoted untiring attention in adapting their machines to suit modern requirements, and especially for the treatment of fibre from estates containing 1,000,000 trees or more, that is, estates having the fibre of from forty to fifty million nuts to be treated every year. Those desiring information on the subject of the best machine to use must give the fullest information concerning their requirements, both as regards the fibre to be treated, its output, the class of finished article required, and so on. Once these come to hand the makers of the various machines can give reliable advice on the subject.

* * * * *

We will conclude this section with details of the necessary plant for treating 10,000 husks per day of ten hours, and converting them into fibre, spinning and cabling the fibre into yarn, and manufacturing such yarn into matting, cords, ropes, &c.

Quantity.	Machine.	Quantity.	Machine.
2	Splitting.	2	Ballot press.
2	Husk crusher.	4	Hand frames.
8	Extractor (breaker).	4	" looms.
4 sets	Spare lags.	2	Braider or plaiter.
2,000	" pins.	72	" bobbins.
8	Extractor (finisher).	1	Bobbin winder.
4 sets	Spare lags.	1	Combing.
2,000	" pins.	1	Shearing.
1	Extractor (special).	1	Cop winder.
500	Spare pins.	1	Calendering.
2	Willowing.	1	Measuring.
24	Brush combs.	1	Matting loom.
4	Fibre cutting.	1	Creel.
1	Hydraulic press.	1	Matting loom.
1	" pump.	1	Creel.
1	Press stop.	1	Matting loom.
1	Milling.	1	Creel.
6	Hackles.	2	Compound rope.
8	Spinners (small).	2	" "
576	" bobbins.	2	Rope strander.
4	Cablers.	1	" closing.
48	" bobbins.	6	Bobbins.
6	Spinners (large).	2	Rope strander.
228	" bobbins.	1	" closing.
4	Cablers (large).	6	Bobbins.
48	" bobbins.	1	Rope baller.
2	Hanking.	1	" coiling.

The Brake Horse Power required is 130.

The space required is 1,000 sq. yd.

In order to determine the capacity and power consumption of some of the machines used in extracting coconut fiber, the Bureau of Science conducted some tests on an available crusher, a special fiber-extracting machine, and a willowing machine. They are manufactured by an apparently reputable concern, have been widely advertised during a score of years, and were in operation at the Surabaya Fiber Exposition where they attracted considerable attention and received favorable comment.

The husks used in the testing of these machines were obtained from nuts used in making copra in Laguna Province, Luzon, which is one of the most important of the coconut-producing districts in the Philippines. They were water-logged when received at the Bureau of Science which was apparently due to their having been transported part of the way in rafts. Judging from the pale, mottled green color they must have been taken from slightly immature nuts.

After the nuts have been harvested, the first step in the extraction process is the removal of the fiber-bearing husk, or pericarp. In the Philippines, this husking operation is performed by impaling the nut manually on a pointed iron blade set vertically in a wooden base, after which the nut is given a sharp twist which pries off part of the husk. These alternate impaling and twisting operations are repeated until all of the husk is removed. There is little similarity in the shape of the husk fragments separated by this method; at times the husks may be separated in halves, at other times in thirds, and if the husk adheres tenaciously the fibrous envelope may come off in much smaller fractions. One man easily can husk one thousand nuts daily by this method, and Prudhomme is under the impression that in the Philippines⁷ three thousand nuts are husked daily by one man.

In order to secure an increased output at lower cost, attempts have been made to construct husking machines. Those that cut husk, shell, and nut into fragmental wedges yield a husk less satisfactory for the manufacture of coir, for in many cases the cuts are across the fiber. The fiber can probably be extracted most satisfactorily from the hand-husked product.

After the husks have been removed from the nut they are soaked in water in order to soften the outer skin and the cellular tissue in which the filaments are embedded, which facilitates the defibering process. The makers of the machines state that the longer the husks are soaked the better the coir obtained,

⁷ Prudhomme, E., *Le Cocotier*, p. 363.

and that long soaking also reduces the fiber-extracting power not a little. The minimum period of maceration is stated at seven days. Some of the husks defibered at the Bureau of Science were soaked in ordinary tap water at room temperature for about ten days and the others were subjected to the cleaning process as received. No appreciable difference was noticed between the especially soaked husks and those used as received with regard to the ease of working and quality of product. This was probably due to the fact that the husks were received so moist that after pressing in the crusher they still appeared wet.

The husk-crushing machine consists of a massive cast-iron frame upon which are mounted two cast-iron, fluted, gear-driven rolls revolving in opposite directions. The clearance between the rolls is adjustable by a hand wheel and, to prevent breakage due to too heavy feed or to the accidental introduction of stones, tools, or other hard bodies, one of the rolls is free to move away against the reaction of two powerful helical springs. The husks, after being torn into fifths to facilitate crushing, were fed into the sheet-iron hopper located above, which has the same width as the rolls. The crushing machine subjected the husks to a kneading and flattening action that loosened the adhering pulp from the filaments. It was necessary to pass the material through the crusher several times before it was sufficiently mashed for the fiber-extracting machine. At the first crushing the clearance of the rolls was at a maximum in order not to clog the machine. At each successive pass the roll clearance was reduced. If the crusher were used in sets, each pair of rolls having less clearance, it is believed that the crushing operation could be carried on more satisfactorily and with less labor. In the manufacturers' catalogue this machine is said to have a capacity of from 5,000 to 8,000 husks per day according to their size, with a drive-pulley speed of 80 revolutions per minute and 2 horse power.

TABLE I.—*Test of crusher.*

Husks fed:	
Kilograms	1,523.5
Number	2,900
Husk capacity of machine:	
Per hour	187
Per 10-hour day	1,870
Power required for driving:	
Kilowatts	1.5
Horse power	2
Time required when each husk is crushed four times: Total,	
15 hours, 31 minutes; per husk, 19 seconds.	

Table I shows that the capacity of the crusher as operated in these tests is much below that given by the makers, perhaps due to the fact that the husks were fed in too large pieces. We were unable to operate the machine with a full hopper. A full-hopper feed invariably clogged the machine because insufficient power was transmitted to the roll-drive pulley; the belt would slip excessively, and finally jump the pulley. This of course could never be tolerated when operating commercially.

The next operation recommended by the makers of the machines after crushing the husk sections is the extraction of the fiber by means of extracting machines generally worked in pairs in order to separate the brush fibers from the spinning fibers. The machines are practically identical, except that the one called the "Breaker," into which the crushed husks are fed, has a scutch wheel fitted with wider-spaced teeth than the other, which is called the "Finisher." The crushed husks are introduced between slowly revolving, fluted feeding rolls that press them against a wooden drum studded with steel pins that scratch them to pieces. The partially disintegrated husk is fed into the finisher, and this completes the extraction of the fiber.

Neither of the machines was tested at the Bureau of Science. Instead, these two machines were substituted by a special fiber-extracting machine that is recommended for defibering young and immature husks, or husks of light growth, or when one does not desire to keep the brush fiber separate from the spinning fiber. This special fiber-extracting machine works on the same principle as the breaker and finisher and, like them, consists mainly of a drum studded with steel teeth, revolving within a sheet-iron housing, and a feeding device for holding the husks while pressed against the drum. The principal difference between this machine and the others consists in a lattice conveyor apron upon which the husks are thrown and on which they are slowly carried forward until seized by the feed rolls. Only a small portion of the husks was completely defibered after the first pass, and many had to be fed through the machine four or five times in order to effect a fair degree of disintegration. Even then there remained groups of filaments or husk fragments, that were firmly held together by the pulp tissue or by the tough epidermis. The fibers obtained by each pass were kept separate. The coarse filaments particularly were frequently injured by having their ends broken off or frayed, perhaps in part due to insufficient preliminary soaking. The manufac-

turers state that this machine will defiber from 1,200 to 1,600 husks per day according to their size, with a consumption of 3 horse power at 160 revolutions per minute.

TABLE II.—*Test of special fiber-extracting machine.*

Husks defibered:	
Kilograms	1,523.5
Number	2,900
Husk capacity of machine:	
Per hour	106
Per 10-hour day	1,060
Coir produced (kilograms)	473.1
Power required for driving:	
Kilowatts	2
Horse power	2.7
Time required to defiber: Total, 27 hours, 13 minutes; per husk, 33 seconds.	

Table II shows that the capacity of the machine is only slightly less than that given by the makers, and also that the power consumption is somewhat below that recommended.

The final machine operation in the extraction of coir is a willowing process which frees the filaments from loosely adherent dust, short fibers, etc. The willowing machine consists of a revolving cylindrical wire cage, in the center of which a shaft, upon which are mounted iron beaters that shake the coir free of dirt, rotates at a higher speed than the cage. The cage may be adjusted at any pitch, depending upon the speed at which the fiber is to pass through the machine, which in turn is determined by the amount of dirt to be removed. The uncleaned fiber is fed into the higher end of the cage, where it is seized by the beater which twirls it about and causes the extraneous matter to fall through the wire netting, and the cleaned coir is eventually discharged at the lower end. When the crushed husks were passed through the special fiber-extracting machine for the first time, the product was composed of the finest filaments with a high percentage of pulp, and each succeeding pass yielded a coarser grade of fiber. The product of each operation was separately cleaned in the willowing machine, thus preserving the grades.

TABLE III.—*Test of willowing machine.*

Husks defibered:	
Number	2,900
Kilograms	1,523
Husk capacity of machine:	
Per hour	211
Per 10-hour day	2,110

TABLE III.—*Test of willowing machine*—Continued.

Coir produced (kilograms)	473.1
Power required:	
Kilowatts	2
Horse power	2.7
Time required to willow: Total, 13 hours, 41 minutes; per husk, 17 seconds.	

The results recorded in Table III for the capacity of the willowing machine, like those of the crusher, are below those given by the makers; the power consumption is slightly greater. During this test the speed of the drive pulley was 308 revolutions per minute, which is about 43 revolutions per minute higher than recommended by the manufacturers, and it was so geared that the beater shaft ran at 214 revolutions per minute and the wire cage at about 5 revolutions per minute. Although the fiber was thoroughly freed from all loosely adherent dust, dirt, and short fibers, it was badly tangled as the result of having been stirred by the beaters.

The design of these machines should be improved, and they should be made to operate with less noise.

ILLUSTRATION

PLATE I

- FIG. 1. **Crushing machine** through which the husks are passed before they are defibered.
2. **Coconut-husk defibering machine.**
3. **Willowing machine**, used for cleaning the raw coconut fiber as it comes from the defiberer.

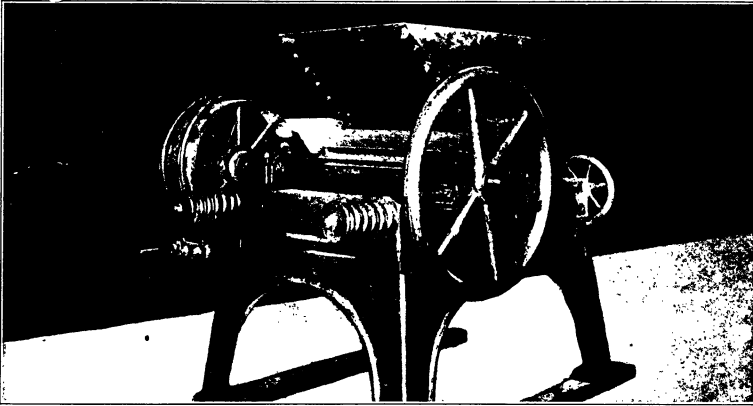

Fig. 1. Crushing machine.

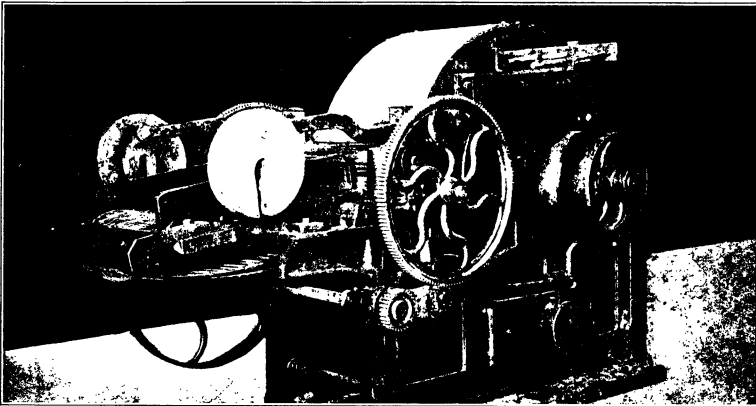

Fig. 2. Coconut-husk defibering machine.

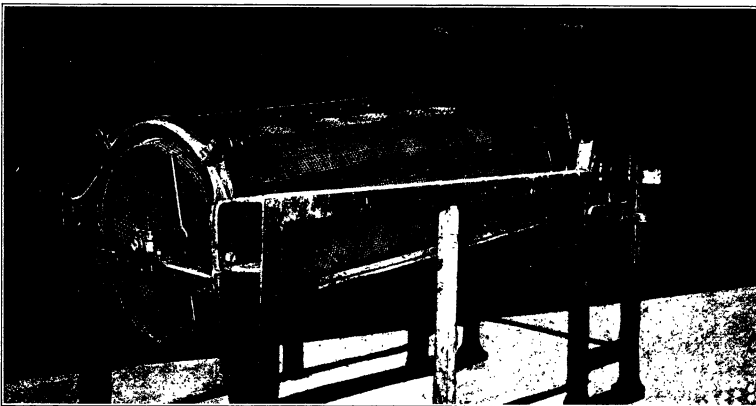

Fig. 3. Willowing machine.

PLATE I.

THE MECHANICAL PROPERTIES OF PHILIPPINE COIR AND COIR CORDAGE COMPARED WITH ABACÁ (MANILA HEMP).¹

By ALBERT E. W. KING

(From the Laboratory of General, Inorganic, and Physical Chemistry,
Bureau of Science, Manila)

FOUR TEXT FIGURES

The information on coconut fiber found in current literature and in reference books and handbooks is characterized by a paucity of precise numerical data. Most of the articles are limited to generalities which dismiss the subject of coir with the statement that the fiber is very resilient, elastic, or tenacious. Usually no quantitative results are given, and many authors have in certain respects misinterpreted the meager or incomplete data at hand. Our present knowledge of the strength and durability of coir cordage is mostly obtainable from the work of Royle.² The investigations of the Marine Board at Calcutta,³ of Roxburgh,⁴ of Wight,⁵ and of others who have studied the subject are not available in the original.

The work of Roxburgh on the comparative strength of twenty-one fiber cords, one of which is coir, before and after maceration in water for one hundred sixteen days is also cited by Prudhomme,⁶ Lecomte,⁷ and Copeland,⁸ but these writers quote Roxburgh's experiments in markedly different ways.

¹ Received for publication August 4, 1918.

² Royle, J. Forbes, *Fibrous Plants of India Fitted for Cordage, Clothing, and Paper*. Smith, Elder, and Co., London; Smith, Taylor, and Co., Bombay (1855), 116, 269, 310, 331-332.

³ Through Royle, *op. cit.*, 331-332.

⁴ 'Observations of the late Dr. William Roxburgh, Botanical Superintendent of the Honourable East India Company's Garden at Calcutta, on the various Specimens of Fibrous Vegetables, the produce of India, which may prove valuable Substitutes for Hemp and Flax, on some future day, in Europe.' Edited by a Friend, and published at the expense of the East India Company, for the information of the Residents, and the benefit that may arise therefrom throughout the Settlements in India. London: 1815. [Cited by Royle, page 6. Roxburgh, first director of the botanical garden at Calcutta, was born in 1759 and died in 1815.]

⁵ Through Royle, *op. cit.*, pp. 116, 310. Wight, director of the botanical garden at Madras, was born in 1796 and died in 1872. None of the writers who quote Wight give references.

⁶ Prudhomme, E., *Le Cocotier*. Augustin Challamel, Éditeur, Paris (1906), 355-356.

⁷ Lecomte, M., quoted by Prudhomme, p. 356.

⁸ Copeland, E. B., *The Coco-nut*. Macmillan & Co., Ltd., London (1914), 183.

Royle² gives the data in the following form:

Comparative Statement of the effect of Maceration 116 days in stagnant water, comparing the strength by weights suspended to four-feet lengths of the various cords therein mentioned, when fresh.^a

No.	NAMES OF THE PLANTS, And brief Remarks on the various Materials employed in these Experiments.	Average Weight at which each sort of Line broke.					
		When fresh.			After 116 days' maceration.		
		White.	Tanned	Tarred.	White.	Tanned	Tarred.
1	English Hemp, a piece of a new tiller-rope.	105			rotten, as was also an English log-line		
2	Hemp, Cannabis, the growth of this season, from the Company's Hemp Farm near Calcutta.	74	139	45	all rotten		
3	Coir, the fibres of the husk of the Cocoa- nut.	87			54		
4	Ejoo, Saguerus Rumphii, Roxb. ^b	96			94		
5	Æschinomene cannabina, Dansha of the Bengalese. The fibres of plants that had nearly ripened their seed.	88	101	84	40	56	65
6	The fibres of the bark of No. 5, from plants coming into blossom.	46	61	48	rotten	68	45
7	Crotalaria juncea, Sunn of the Bengalese	68	69	60	rotten	51	65
8	Corchorus olitorius, Bunghee-Paat. The fibres of its bark called Jute.	68	69	61	40	49	60
9	Corchorus capsularis, Ghee-Nalta-Paat. The fibres called Nalta-Jute.	67			50		
10	Flax, Linum usitatissimum, the growth of the Company's Hemp Farm near Calcutta.	39			rotten		
11	Agave americana	110	79	78	rotten	rotten	15½
12	Sansevieria zeylanica; in Sanscrit Murva	120	73	48	30	26	34
13	Abroma augusta. Woollet-comul of the Bengalese.	74	58	44	38	54	50
14	Guazuma ulmifolia, Bastard-Cedar. The fibres of the bark of some straight lux- uriant young plants.	52	47	45	30	39	
15	Hibiscus tiliaceus, Bola of the Bengalese	41	62	61	40	55	70
16	Hibiscus strictus, from the Moluccas, a tall, white-flowered variety of it.	61			26		
17	Hibiscus mutabilis	45	53		rotten	45	
18	Hibiscus, from the Cape of Good Hope	22			17		
19	Bauhinia racemosa, Roxb., a large scan- dent species.	69			rotten		
20	The same as No. 19, only maceration was used to help to take the bark off the twigs with more ease.	56			rotten		
21	erculia villosa	53			30		

^a The values are apparently in pounds.—A. E. W. K.

^b *Arenga saccharifera* (Wurmb.) Labill.

As presented by Prudhomme only thirteen tests are included, the English values having been converted into the corresponding metric ones and, in addition, the title of the table changed to read as if Roxburgh's experiments had been conducted on cords of the same size. The size of the cords is not mentioned in the table quoted by Royle, from whom Prudhomme obtained his data through M. Lecomte.

Copeland still further condenses Roxburgh's data by omitting thirteen of the twenty-one fibers and by dropping the tests on tanned and tarred specimens. He fails to state that the fibers were tested in the form of cords, and neglects to include the lengths of the specimens tested; nor does he state where his data were obtained.

Wight's results on the comparative strength of coir rope are quoted more frequently than Roxburgh's, and often constitute the only numerical data accompanying an article on coconut fiber. The former results are cited in several different ways by Spon,⁹ Watt,¹⁰ Vétillart,¹¹ Mitchell and Prideaux,¹² Dodge,¹³ and Matthews.¹⁴ Royle¹⁵ gives the following as the results of Doctor Wight's experiments:

	Pounds.
Coir	224
Pooley Mungee (<i>Hibiscus cannabinus</i>)	290
Marool (<i>Sansevieria zeylanica</i>)	316
Cotton (<i>Gossypium herbaceum</i>)	346
Cutthalay nar (<i>Agave americana</i>)	362
Janapa (<i>Crotalaria juncea</i>), Sunn, hindee	407
Yercum (<i>Calotropis gigantea</i>)	552

Some of the designations are in the Indian vernacular. According to this table coir is the weakest of the seven fibers tested; in another place Royle¹⁶ restates a part of the same data, but

⁹ Spons' Encyclopaedia of the Industrial Arts, Manufactures, and Raw Commercial Products, edited by Chas. G. Warnford Lock. E. & F. N. Spon, London and New York (1882), 1, 940.

¹⁰ Watt, Geo., A Dictionary of the Economic Products of India. Government of India Central Printing Office, Calcutta (1889), 2, 437.

¹¹ Vétillart, M., Études sur les Fibres Végétales Textiles Employées dans L'Industrie. Librairie de Firmin-Didot et Cie., Paris (1876), 244-245.

¹² Mitchell, C. A., and Prideaux, R. M., Fibres Used in the Textile and Allied Industries. Scott, Greenwood & Son, London (1910), 178.

¹³ Dodge, Chas. R., A Descriptive Catalogue of Useful Fiber Plants of the World. Government Printing Office, Washington (1897), 121-123.

¹⁴ Matthews, J. M., The Textile Fibres, Their Physical, Microscopical and Chemical Properties. John Wiley & Sons, New York; Chapman & Hall, Limited, London (1913), 448-450.

¹⁵ Loc. cit.

gives 190 pounds instead of 290 pounds as the strength of *Hibiscus cannabinus*. He says:

The comparative strength of Coir cordage is well known, but we may, nevertheless, mention, that in some experiments made by Dr. Wight, Coir cordage broke with 224 lb., when *Hibiscus cannabinus* bore only 190 lb., but the Moorva, [*Sansevieria zeylanica*] 316 lb.

The latter form puts coir in a more favorable light and is the way in which Wight's data are quoted by Matthews,¹⁷ Dodge,¹⁷ and Vétillart.¹⁷ All of these authors misspell Wight's name, referring to him as "Wright."

Spons' Encyclopaedia¹⁸ reduces Wight's results to a single statement: "In Dr. Wight's experiments, coir cordage broke at 224 lb."

Watt¹⁹ devotes about eleven pages to the discussion of coir cordage, but his only reference to test data is the statement already quoted from Spons' Encyclopaedia. Mitchell and Prideaux pass over the tensile strength of coir by saying: "According to Wright [*sic*] its strength as compared with hemp is as 224 : 190."

The bare statement that a particular piece of coir cordage broke at 224 pounds, unaccompanied by additional information as to circumference, diameter, number of strands, or weight per unit length, is of very little use. Owing to their incompleteness it is evident that Roxburgh's results as quoted by Royle and others, also have little value for the purpose of comparison with tensile-test data secured by other investigators along similar lines. The changes in form that they have suffered at the hands of certain writers have not increased their usefulness. Royle is the only writer who mentions that Roxburgh's specimens were ruptured by weights suspended from them. Undoubtedly the results were obtained under rather disadvantageous conditions, such as difficulty in applying the load uniformly or in adding sufficiently small increments, difficulties that the use of modern testing machines have overcome. The quotations given are typical of the published literature on the physical properties of coir cordage, and show that the data therein presented do not justify the expressed opinions that coir is elastic;²⁰ that

¹⁶ Op. cit., 116.

¹⁷ Loc. cit.

¹⁸ Loc. cit.

¹⁹ Op. cit., 426-437.

²⁰ Matthews, loc. cit.; Mitchell and Prideaux, loc. cit.; Dodge, loc. cit.; Watt, op. cit.; Vétillart, loc. cit.; Copeland, loc. cit.

it is exceptionally tenacious;²¹ that it is resilient;²² that it is one of the best fibers for ships' cables;²³ and that it is particularly suited to withstand jerks,²⁴ sudden heavy strains,²⁵ and mechanical wear.²⁶

The object of this paper is to present precise data on the tensile strength, elongation, and elastic properties of Philippine coconut fiber. Results given are on tests performed on single filaments and on coir rope. It is believed that this is the first time actual numerical data on the modulus of tensile elasticity and on the tensile resilience of coir have been computed and published.

Coir is obtained from the husk, or pericarp (called "bonot" in many Filipino dialects), of the fruit of the coconut palm. In the Philippines, up to the present time, most husks have been either burned as fuel or allowed to rot. No figures are available as to the number annually worked for fiber, but the quantity is small, and the industry has no commercial importance, in spite of efforts made to encourage it. It has been estimated that 735,000,000 coconuts were gathered in the Philippine Islands in 1916, from the husks of which approximately 80,850 tons of coir might have been realized, sufficient to make coir mats having a wholesale value of 45,000,000 pesos. In southern India, Ceylon, Java, and the Malay Peninsula coir is the basis of a paying industry. In these countries coir and coir products, in the form of yarns, cordage, and mats, figure as articles of export. Java and Singapore supply practically all of the coir doormats used in the United States.²⁷

The fiber of commerce, when not discolored, is usually sorted by hackling or combing into three grades according to length and fineness. Brush or bristle fiber is composed of the coarsest and stiffest filaments and, as the name indicates, is used for making brushes. They are very stiff and decidedly woody. Mat fiber consists of the finer, soft, fragile, and hairlike filaments used for spinning mat and rope yarns. Coir tow is used for stuffings in upholstery.

Extraction of the fiber.—The Filipinos extract the coir from

²¹ Matthews, loc. cit.; Dodge, loc. cit.; Vétillart, loc. cit.

²² Fraker, *Philippine Craftsman* (1915-1916), 4, 596-600.

²³ Matthews, loc. cit.; Dodge, loc. cit.; Watt, loc. cit.; Fraker, loc. cit.

²⁴ Copeland, loc. cit.; Fraker, loc. cit.

²⁵ Fraker, loc. cit.

²⁶ Matthews, loc. cit.

²⁷ Commerce Reports. Washington, D. C. (July 14, 1917), No. 163, pp. 164-165; *Philipp. Agr. Rev.* (1918), 11, 7.

the husks by hand, employing two different methods. In the one the fresh husks are beaten on the convex side with a mallet, stone, or club, until the fibers are freed from the corky cellular tissue. This process is used by the school children and an insignificant quantity is extracted, from which doormats and other household articles are made. In the other process the husks as a rule are split into segments, to facilitate the action of water and of the retting bacteria, and they are steeped in either fresh or brackish water, according to the locality, until sufficiently decomposed to loosen the fiber. The filaments are then separated from the pulp matrix by beating and by washing in water. Generally no attempt is made to sort the fiber. After the fiber has been dried in the sun, it is ready for use. In certain parts of the Archipelago where the coconut palm abounds, extraction of the fiber by this process is practiced to a limited extent as a household industry. The coir thus secured is generally fabricated into articles for personal use, and it seldom finds its way into the market. It is sometimes used by the farmer and by the owners of native sailing craft for fabricating inferior, ragged-looking cordage. Both methods of extraction are slow and tedious, particularly the one in which the husks are macerated in water for periods varying from a few weeks to several months, the time depending upon the practice in vogue in the particular locality.

For the production of coir on a large scale there have been manufactured power-driven machines of various sorts which, together with their operation, have been described by Hamel Smith and Pape.²⁸ The Bureau of Science has made tests to determine the capacity of some of these,²⁹ the power required for their operation, and the quality of the product.

Description of coir tested.—Two different samples of coir were tested. One was machine extracted at the Bureau of Science, from fresh husks of coconuts grown in Laguna Province. The other came from Caoayan, Ilocos Sur, in the form of rope 50 millimeters in circumference, the fiber having been extracted by pounding husks that had been steeped in brackish water.

Most of the machine-cleaned filaments were smooth and free from waste material. Owing to the violent shaking, fanning, and tumbling action to which they had been subjected in the willowing machine, the filaments were entirely free from loosely adherent pulp, dust, and tow. Some were so smooth that it

²⁸ Hamel Smith, H., and Pape, F. A. G., *Coco-nuts: The Consols of the East*. "Tropical Life" Publishing Dept., London (1912).

²⁹ Valencia, F. V., *Mechanical extraction of coir*, *antea*, 275.

seemed as though the surface had been polished. However, not all of the fiber was so thoroughly cleaned. Some was contaminated with the tough epidermal tissue which was present in sufficient quantities to bind the filaments together.

The retted fiber was not so clean as that extracted mechanically and therefore had a rough appearance. It was not only contaminated with adherent pulp and leathery epidermal tissue, which often bound the filaments into loose bundles, but was also cluttered with appreciable quantities of loose waste material that fell out largely in the form of dust on untwisting the rope. This waste material, which consisted of pulp, dirt, short fibers, and tow, increases both bulk and weight, but does not add to the strength of the rope.

There is a marked difference in color between the two samples of coir. The retted fiber is buckhorn brown and the machine-cleaned fiber is hazel.³⁰ Hazel is the true color of the filaments, and the buckhorn brown color of the retted fiber is due to a thin film of tissue from the husks that the cleaning process failed to remove. Simply passing the filament several times between the thumb nail and the tip of the index finger will remove this coating of pulp, when the true hazel color appears.

Many of the machine-extracted filaments have frayed and split ends, and sometimes the tips are broken off completely, apparently due to the spiked drum that extracted the fiber from the husks. These injured ends reduce the effective length of the already short filaments, and must be cut off before they can be subjected to tensile test, in order to avoid rupture which would inevitably occur in the jaws of the testing machine.

Dimensions of coir filaments.—A series of measurements made of thirty-nine representative machine-cleaned filaments shows an average length of 245 millimeters, of which the minimum is 174 and the maximum 299 millimeters. Measurements of fifty-three different retted filaments show an average length of 228 millimeters, of which the minimum and maximum lengths are 111 and 290 millimeters, respectively. Additional measurements of retted and machine-cleaned filaments are given in Tables I and II. The cross-sectional dimensions were obtained by a micrometer caliper registering to the thousandth part of an inch. In the case of the fine filaments that are comparatively soft and yielding, especial care was exercised to obtain trustworthy measurements.

³⁰ Ridgway, R., *Color Standards and Color Nomenclature*. Published by the author in Washington, D. C. (1912). Plates XIV and XV.

TABLE I.—Dimensions of machine-cleaned coir filaments from Laguna husks.

Total length of filament.		Cross-sectional dimensions at two points that divide the filament into thirds.				Remarks.
		Width.		Thickness.		
mm.	in.	mm.	in.	mm.	in.	
189	7.44	0.939	0.037	0.482	0.019	Very coarse filament.
		0.889	0.035	0.584	0.023	
205	8.08	0.888	0.035	0.609	0.024	Do.
		0.660	0.026	0.508	0.020	
299	11.77	0.685	0.027	0.432	0.017	Coarse elliptical-sectioned filament.
		0.609	0.024	0.457	0.018	
261	10.28	0.558	0.022	0.330	0.013	Coarse filament.
		0.533	0.021	0.381	0.015	
271	10.67	0.533	0.021	0.457	0.018	Do.
		0.508	0.020	0.355	0.014	
273	10.75	0.584	0.023	0.533	0.021	Coarse filament with a marked taper.
		0.457	0.018	0.330	0.013	
235	9.25	0.457	0.018	0.406	0.016	Medium filament.
		0.381	0.015	0.279	0.011	
229	9.03	0.254	0.010	0.229	0.009	Fine filament.
		0.178	0.007	0.178	0.007	
115	4.53	0.203	0.008	0.178	0.007	Very fine circular-sectioned filament.
		0.178	0.007	0.152	0.006	
119	4.68	0.178	0.007	0.127	0.005	Very fine filament.
		0.152	0.006	0.152	0.006	

TABLE II.—Dimensions of retted coir filaments from Ilocos Sur.*

Total length of filament.		Cross-sectional dimensions at two points that divide the filament into thirds.				Remarks.
		Width.		Thickness.		
mm.	in.	mm.	in.	mm.	in.	
201	7.92	0.838	0.033	0.508	0.020	Coarse filament, elliptical in cross section.
		0.787	0.031	0.508	0.020	
278	10.95	0.685	0.027	0.432	0.017	Coarse filament.
		0.584	0.023	0.558	0.022	
290	11.42	0.685	0.027	0.533	0.021	Do.
		0.381	0.015	0.381	0.015	
264	10.39	0.635	0.025	0.432	0.017	Coarse filament, elliptical in cross section.
		0.584	0.023	0.355	0.014	
235	9.25	0.634	0.025	0.381	0.015	Do.
		0.508	0.020	0.406	0.016	
246	9.69	0.406	0.016	0.305	0.012	Fine filament.
		0.127	0.005	0.127	0.005	
251	9.89	0.305	0.012	0.254	0.010	Fine filament, circular in cross section.
		0.178	0.007	0.152	0.006	
220	8.66	0.203	0.008	0.178	0.007	Very fine filament, circular in cross section.
		0.102	0.004	0.102	0.004	
240	9.45	0.152	0.006	0.152	0.006	Very fine filament.
		0.127	0.005	0.127	0.005	
151	5.95	0.152	0.006	0.152	0.006	Very fine filament, circular in cross section.
		0.102	0.004	0.102	0.004	

* Any pulp adhering to the filament was scraped off before calipering.

Tables I and II show the diversity of the filaments in cross section. They vary from specimens with fine circular sections having a diameter of 0.152 millimeter to those with very coarse elliptical sections having a width of 0.939 millimeter and a thickness of 0.482 millimeter. Between these two extreme types are filaments having a variety of irregular cross sections. In fact, it is not uncommon to find differently shaped cross sections at various points in the same filament. Fine and medium filaments tend to have a circular section whereas the coarse ones, and particularly those that are very coarse, are invariably elliptical. Most of the filaments of the two samples tested are slightly tapered, as is clearly shown in Tables I and II. For the sake of simplicity in calculation the cross-sectional areas of the single filaments at the point of rupture were considered to be either perfectly elliptical or perfectly circular. For all general purposes the difference between the true area and the calculated area is so small as to be insignificant. It will be seen that most of the filaments are characterized by two principal cross-sectional dimensions: (1) a maximum diameter and (2) a minimum diameter, which have been designated width and thickness, respectively, in Tables I and II.

PHYSICAL PROPERTIES OF COIR FILAMENTS IN TENSION

Description of testing apparatus used.—For determining the tensile strength, tensile elasticity, elongation, and permanent set of single coir filaments, I devised a simple but accurate apparatus. A sketch of the mechanism with a filament clamped in place is shown in fig. 1. It consists of two paper-lined grips, *J-J'*, for clamping the filament; a rigid stand, *S*, for supporting the gripping elements; a cardboard scale, *A*, graduated in millimeters for determining the elongation of the test specimen; and a device, *H, K, V, T*, for applying the load at a constant rate and cutting it off at the desired instant. From the lower grip, *J'*, is hung a pan, *P*, for receiving the small lead shot with which the hopper, *H*, is filled and which flows through the spout, *K*, when the valve, *V*, is opened. The device for applying the load at a constant rate is an auxiliary shot-feeding reservoir used in connection with a Michaelis cement-briquet testing machine. It consists essentially of a smooth sheet-metal hopper, *H*, supported on a tripod, *R*, the bottom of the hopper terminating in a spout, *K*, which is closed by an adjustable valve, *V*. A trigger, *T*, located at the base of the tripod, automatically holds the valve open and shuts off the flow of shot at the instant of rupture when

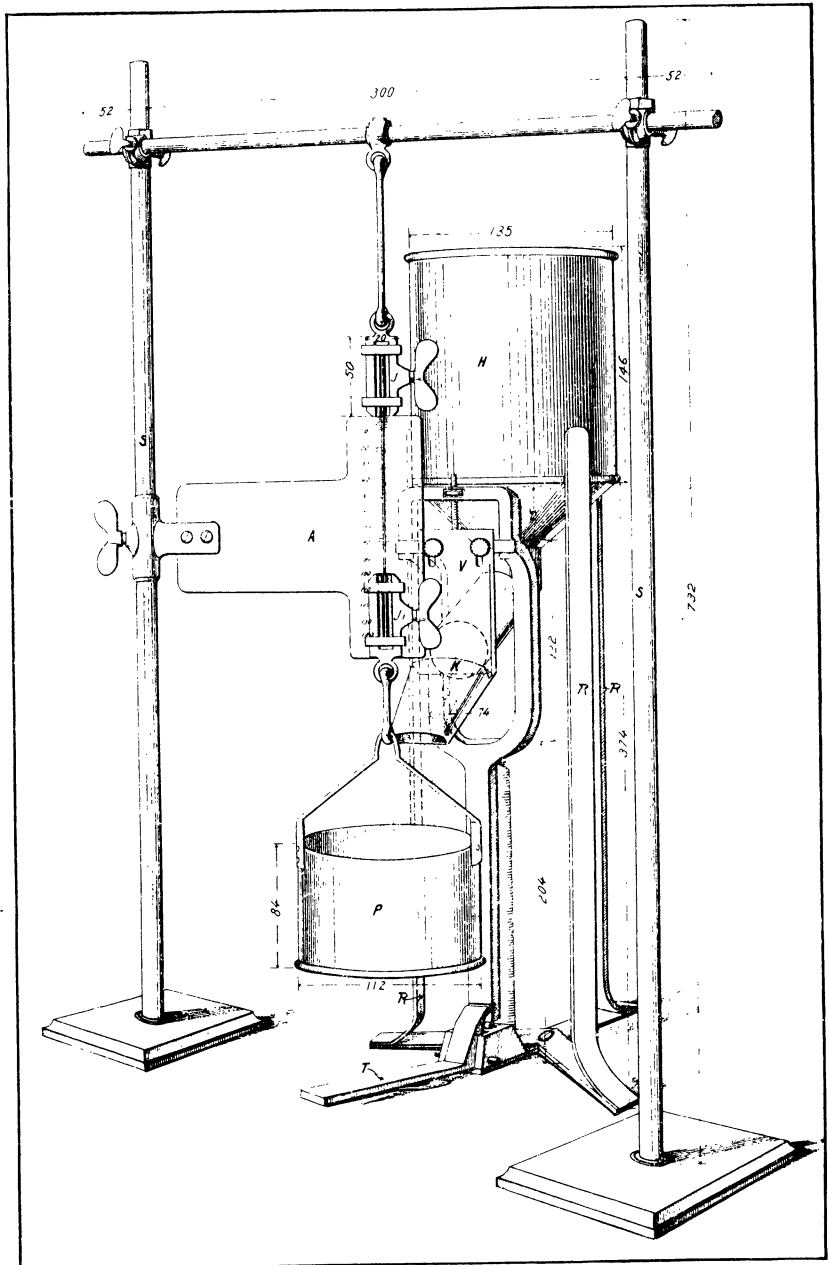

FIG. 1. Mechanical device for determining the elastic constants of coir and abacá filaments.

the pan, *P*, falls. In these tests the valve was adjusted to the smallest working aperture, so that the shot issued at the lowest average rate, 33 grams per second.

Technic of testing.—In testing a filament the exposed length was adjusted to 100 millimeters as shown on the scale, the specimen previously having been cut to a length of 150 millimeters to provide 25 millimeters to be clamped firmly in each grip. Care must be exercised that the filament will not slip in the grips. Grips made of metal mash the filament, causing rupture in the jaws; in order to prevent such injury the jaws were lined with Bristol board. The final step before beginning the test was the careful adjustment of the shot pan suspended on a hook on the lower grip. While one operator started the flow of shot by pushing up on the yoke to which the valve is fastened, another snapped a stop watch the instant the valve opened. The first operator, sighting at right angles to the length of the specimen over the upper end of the descending lower grip, called aloud the graduations of the scale at the instant they were uncovered, and the second operator simultaneously recorded the corresponding number of seconds in a table previously prepared in blank. The elongation was read at 1-millimeter intervals. When the filament broke, the loaded shot pan fell on the trigger, thus instantaneously closing the valve, and at the same instant the watch was stopped. The duration of the test and the weight of the shot and pan were recorded. From these data the tensile strength, elongation, and elasticity of the filaments were calculated. For the purpose of comparison, similar tests were performed upon abacá (Manila hemp) filaments. Since there are no bearings, knife edges, or other points of contact in the device that might cause friction and so affect the results, the values obtained are probably more accurate than could be secured with most testing machines on the market.

Tensile strength.—Tables III and IV give the results of tests made on the tensile strength of machine-cleaned and retted coir filaments, respectively, and Table V gives results of tests with abacá filaments.

The results show that the machine-cleaned coir filaments from Laguna are considerably stronger than the retted filaments from Ilocos Sur. However, when compared with grade "F" abacá filaments, which are standard for cordage manufacture, the low tensile strength of coir is evident. Whereas the maximum tensile strength of coir is only 1,546 kilograms per square centimeter, abacá shows a tensile strength of 8,570 kilograms per

TABLE III.—Tensile-strength tests of single filaments 100 millimeters in length, of machine-cleaned coir from Laguna husks.

Cross-sectional dimensions of filaments at two places one-third distant from each end.										Duration of test.	Elongation at the instant of rupture.	Actual breaking load.	Ultimate tensile strength per unit area.		Remarks.
Width.		Thickness.		Area.		Kilos per sq. cm.	Pounds per sq. in.	Actual breaking load.							
mm.	in.	mm.	in.	Sq. mm.	Sq. in.			g.	lbs.						
0.813	0.032	0.457	0.018	0.292	0.000452	101	25	3,087	6.70	1,040	14,800	Broken in upper jaw.			
0.888	0.035	0.584	0.023	0.408	0.000632										
0.787	0.031	0.559	0.022	0.345	0.000535	105	29	3,241	7.15	938	13,350	Rupture O. K. in upper section.			
0.837	0.033	0.508	0.020	0.334	0.000518										
0.762	0.030	0.482	0.019	0.289	0.000448	92	30	2,948	6.50	1,146	16,300	Rupture O. K. in lower section.			
0.762	0.030	0.431	0.017	0.258	0.000400										
0.584	0.023	0.457	0.018	0.210	0.000325	91	36	2,755	6.06	1,546	22,000	Do.			
0.558	0.022	0.406	0.016	0.178	0.000276										
0.381	0.015	0.279	0.011	0.084	0.000130	30	35	1,006	2.22	1,200	17,100	Rupture in upper jaw.			
0.254	0.010	0.229	0.009	0.046	0.000071	17	31	637	1.40	1,377	19,600	Do.			
0.305	0.012	0.254	0.010	0.061	0.000094										
Average							31			1,208	17,192				

TABLE IV.—*Tensile-strength tests of single filaments 100 millimeters in length, of retted coir from Ilocos Sur.*

Cross-sectional dimensions of filaments at two places one-third distant from each end.				Duration of test.	Elongation at the instant of rupture.	Actual breaking load.		Ultimate tensile strength per unit area.		Remarks.		
Width.		Thickness.				Area.		g.	lbs.		Kilos per sq. cm.	Pounds per sq. in.
mm.	in.	mm.	in.	Sq. mm.	Sq. in.	Seconds.	Per cent.	g.	lbs.	Kilos per sq. cm.	Pounds per sq. in.	
0.838	0.033	0.508	0.020	0.334	0.000518	81	31	2,360	5.20	750	10,560	Rupture in lower jaw.
0.787	0.031	0.508	0.020	0.314	0.000487							
0.685	0.027	0.381	0.015	0.205	0.000318	54	32	1,603	3.53	731	10,400	Rupture O. K. in lower section.
0.609	0.024	0.457	0.018	0.219	0.000339							
0.584	0.023	0.355	0.014	0.163	0.000253	68	39	2,003	4.41	927	13,200	Do.
0.635	0.025	0.432	0.017	0.215	0.000334							
0.508	0.020	0.457	0.018	0.183	0.000283	52	31	1,679	3.70	920	13,100	Rupture O. K. in upper section.
0.533	0.021	0.432	0.017	0.181	0.000280							
0.482	0.019	0.305	0.012	0.115	0.000179	30	20	978	2.16	860	12,100	Do.
0.558	0.022	0.431	0.017	0.190	0.000294							
0.229	0.009	0.203	0.008	0.036	0.0000555	13	26	531	1.17	872	12,400	Rupture in lower jaw.
0.305	0.012	0.254	0.010	0.061	0.0000943							
Average							30			832	11,900	

TABLE V.—Tensile-strength tests of single-filament sections of abacá (grade "F"), 100 millimeters long.

Cross-sectional dimensions of filaments at two places one-third distant from each end.				Area.	Duration of test.	Elongation at the instant of rupture.	Actual breaking load.		Ultimate tensile strength per unit area.	Remarks.		
Width.		Thickness.					g.	lbs.			Kilos per sq. cm.	Pounds per sq. in.
mm.	in.	mm.	in.	Sq. mm.	Sq. in.	Seconds.	Per cent.	g.	lbs.	Kilos per sq. cm.	Pounds per sq. in.	
0.381	0.015	0.203	0.008	0.0608	0.000943	68	4	2,280	5.03	3,750	53,400	Rupture O. K. in upper section.
0.406	0.016	0.178	0.007	0.0560	0.000868							
0.381	0.015	0.178	0.007	0.0533	0.000825	88	4.5	2,764	6.09	6,000	85,300	Rupture in lower jaw.
0.406	0.013	0.178	0.007	0.0461	0.000714							
0.330	0.013	0.178	0.007	0.0461	0.000714							
0.330	0.013	0.127	0.005	0.0329	0.000510							
0.305	0.012	0.178	0.007	0.0425	0.000659	86	4	2,765	6.08	8,240	107,600	Elongation at point of rupture taken only; stop watch snapped too late.
0.279	0.011	0.152	0.006	0.0334	0.000518							Break O. K. in lower section.
0.305	0.012	0.178	0.007	0.0425	0.000659	80	3	2,585	5.59	8,340	118,600	Do.
0.254	0.010	0.152	0.006	0.0304	0.000471							Do.
0.279	0.011	0.152	0.006	0.0334	0.000518	81	3	2,560	5.65	8,430	120,000	
0.254	0.010	0.152	0.006	0.0304	0.000471							
0.229	0.009	0.102	0.004	0.0185	0.000283	52	2.5	1,563	3.45	8,570	121,700	Rupture O. K. in upper section.
0.203	0.008	0.127	0.005	0.0203	0.000314							
Average							3.6			7,270	103,400	

square centimeter. Still higher values for abacá are frequently obtained.

These tensile strengths of Philippine coir filaments agree with the results published by M. H. Lecomte. This work is quoted by Prudhomme³¹ as follows:

“* * * Un filament de huit centimètres de long et de 250 μ ” de diamètre a supporté 650 grammes avant de se rompre. * * *” (A filament eight centimeters long and 0.250 millimeter in diameter broke under a load of 650 grams.)

Since a diameter for the filament is given it must be presumed that the filament section is circular and, therefore, its area would be

$$\left(\frac{0.250}{2}\right)^2 \times 3.1416 = 0.0490 \text{ square millimeter,}$$

which is equivalent to 0.000490 square centimeter. The ultimate unit breaking stress is

$$0.650 \times \frac{1}{0.000490} = 1,327 \text{ kilograms per square centimeter.}$$

This value agrees closely with the average values given in Tables III and IV. It is slightly greater than the tensile strength of the retted fiber, 1,208 kilograms per square centimeter; less than the ultimate resistance of the machine-cleaned fiber, 1,526 kilograms per square centimeter; and practically equal to the mean of the two values, 1,367 kilograms per square centimeter.

Extensive comments occur in existing literature to the effect not only that the filaments obtained from husks of overripe nuts are characterized by dark color, stiffness, coarseness, weakness, and brittleness, and that nuts having an age of between 9 and 10 months yield a finer and lighter-colored fiber, but also that the varying strengths of coir depend upon a slight difference in the age of the nuts. No authoritative data have been collected as to the effect age has on the tensile strength of coir. In as much as the tensile strength of coir is very low, were the age of the nuts to determine its strength it is improbable that this factor would be sufficient materially to increase its value as a cordage material. I doubt if there is much difference be-

³¹ Loc. cit.

³² 1 μ = 0.001 millimeter.

tween the tensile strength of coir obtained from husks from which copra has been made and that of coir obtained from slightly immature nuts, so highly recommended. While it is evident that the machine-cleaned filaments from Laguna husks possess a higher average tensile strength than the retted filaments from Ilocos Sur, no definite conclusions can be drawn as to the cause of the difference. It may be due to any of a number of causes; such as a difference in the age of the husk, the action of salt water on the retted fiber, the variety of the coconuts, the nature of the soil upon which the nuts were grown, climatic conditions, etc.

Elongation.—Perhaps the most characteristic and striking property of coir is its extraordinary elongation when subjected to tension. There is little difference between the retted and machine-cleaned filaments in this respect, the average being about 30 per cent for each kind. Since extensibility is a measure of ductility, the data given in Tables III and IV also show that coir is a highly ductile fiber.

Burr³³ says:

One of the most important and valuable characteristics of any solid material is its "ductility," or that property by which it is enabled to change its form, beyond the limit of elasticity, before failure takes place. It is measured by the permanent "set," or stretch, in the case of a tensile stress, which the test piece possesses after fracture; also, by the decrease of cross-section which the piece suffers at the place of fracture.

Unfortunately most writers on coir have erroneously interpreted high ductility to mean high elasticity. Per se there is no connection between the ductility and the elastic properties of a material, and most writers confuse deformation with elasticity.

Elasticity.—Before proceeding with the detailed discussion of the elastic properties of coir I desire to quote typical passages from the literature that show the misuse of the term "elasticity" as applied to coir.³⁴

Watt³⁵ states:

The merits of coir as a rope fibre are now fully appreciated throughout the world, the ELASTICITY and lightness of the fibre making it eminently suited for this purpose. But to these properties has to be added its great power of withstanding moisture even under continued actual submersion.

³³ Burr, Wm. H., *The Elasticity and Resistance of the Materials of Engineering*. Chapman & Hall Limited, London; John Wiley & Sons, Inc., New York, 6th ed. (1913), 204.

³⁴ Small capitals are employed to emphasize the words misused.

³⁵ Watt, Geo., *op. cit.* 437.

On these grounds it is in great demand for maritime purposes as hawsers, although its roughness renders it unserviceable for standing riggings, its ELASTICITY being for such purposes a disadvantage. It is, however, better suited for running riggings, its lightness being taken advantage of. In the *British Manufacturing Industries* (on Fibres and Cordage) it is stated, "Coir is one of the best materials for cables on account of its lightness ELASTICITY and strength. It is durable and little affected when wetted with salt water. Numerous instances have been related of ships furnished with this light, buoyant, and ELASTIC material riding out a storm in security, while the stronger-made, though less ELASTIC, ropes of other vessels have snapped in two * * *."

Copeland³⁶ says:

The chief peculiarity of coir rope is its ELASTICITY. The coco-nut fibre will stretch fully 25 per cent without breaking. The amount which ropes made of it will stretch depends upon the method of manufacture, but in all cases they will stretch more than ropes made of any other of the commercial fibres. This makes coir rope especially desirable where it is subjected to jerks. * * *

From what has been said as to the qualities of the coir, it follows that for ropes it is to be recommended where ELASTICITY or resistance to decay are especially desired; * * *

Dodge³⁷ writes:

"The character of coir has long been established in the East, and is now in Europe, as one of the best materials for cables, on account of its lightness as well as ELASTICITY." Ships furnished with coir cables have been known to ride out a storm in security while the stronger made, but less ELASTIC, ropes of the other vessels snapped like pack thread. Coir cables were used extensively in the Indian seas until chain cables were introduced. It is rougher to handle and not so neat looking as hemp rigging, but it is well suited to running rigging where lightness and ELASTICITY are desired, as for the more lofty sheets; it, however, is too ELASTIC for standing rigging. In vessels of 600 tons it is generally used for lower rigging.

A body is said to be elastic if, after being deformed by an external force, it will spring back to its original shape and dimensions when the deforming force ceases to act. Tensile elasticity is the resistance to an increase in its length exercised by a body under tension. The results of representative tensile elasticity tests of single filaments of both retted and machine-cleaned coir fibers are given in Tables VI and VII. For purposes of comparison the results of similar tests on grade "F" abacá filaments are given in Table VIII.

³⁶ Copeland, E. B., op. cit., 182-184.

³⁷ Dodge, Chas. R., loc. cit.

TABLE VI.—Tensile elasticity of single filaments of coir taken from Ilocos Sur rope.

TEST 1.

Cross-sectional dimensions of filament at two places one-third distant from each end of the 100 mm. testing length.		Thickness.		Area.		Applied load.	Elongation in 100 mm. testing length.	Modulus of elasticity.	Remarks.			
mm.	in.	mm.	in.	Sq. mm.	Sq. in.							
						lbs.	Kilos per sq. cm.	Pounds per sq. in.	Per cent.	Kilos per sq. cm.	Pounds per sq. in.	
						<i>a.</i>						Duration of test, 54 seconds; rupture O. K. in lower section.
0.685	0.027	0.381	0.015	0.205	0.000318	300	0.662	137	1,950	1	13,700	195,000
0.609	0.024	0.457	0.018	0.219	0.000339	480	1.06	220	3,130	2	11,000	157,000
						600	1.32	274	3,890	3	9,140	130,000
						660	1.46	303	4,300	4	7,560	107,500
						750	1.65	342	4,860	5	6,840	97,200
						780	1.72	357	5,080	6	5,950	84,600
						870	1.92	398	5,660	9	4,420	62,800
						930	2.05	425	6,050	11	3,870	55,000
						1,020	2.25	467	6,640	14	3,340	47,400
						1,080	2.39	496	7,050	16	3,100	41,000
						1,170	2.58	534	7,610	19	2,810	40,000
						1,260	2.78	572	8,200	22	2,620	37,300
						1,350	2.98	618	8,790	25	2,470	35,100
						1,500	3.31	687	9,770	29	2,370	33,700
						1,560	3.44	713	10,140	31	2,300	32,700
						1,603	3.53	731	10,400	32	2,290	32,500

TABLE VI.—Tensile elasticity of single filaments of coir taken from Ilocos Sur rope—Continued.

TEST 4.

Width.		Thickness.		Area.		Applied load.				Elongation in 100 mm. testing length.		Modulus of elasticity.		Remarks.
mm.	in.	mm.	in.	Sq. mm.	Sq. in.	g.	lbs.	Kilos per sq. cm.	Pounds per sq. in.	Per cent.	Kilos per sq. cm.	Pounds per sq. in.		
						290	0.639	135	1,915	1	13,600	191,500	Duration of test, 68 seconds; rupture O. K. in lower section.	
						465	1.03	217	3,090	2	10,800	154,500		
						580	1.28	269	3,830	3	9,000	128,000		
						638	1.41	297	4,220	4	7,420	105,500		
						696	1.53	322	4,580	5	6,450	91,700		
						755	1.67	352	5,000	6	5,890	83,300		
						842	1.86	392	5,570	9	4,340	61,800		
						928	2.05	431	6,130	12	3,600	51,200		
0.534	0.023	0.355	0.014	0.163	0.00253	1,015	2.24	472	6,710	15	3,140	44,700		
0.635	0.025	0.482	0.017	0.215	0.00334	1,073	2.37	498	7,090	18	2,770	39,400		
						1,160	2.56	539	7,670	20	2,700	38,350		
						1,305	2.88	606	8,630	24	2,530	35,900		
						1,393	3.07	646	9,190	27	2,390	34,000		
						1,507	3.33	700	9,970	30	2,330	33,200		
						1,595	3.52	740	10,500	32	2,310	32,900		
						1,740	3.84	808	11,500	35	2,310	32,900		
						1,940	4.28	900	12,800	38	2,370	33,700		
						2,003	4.41	927	13,200	39	2,380	33,900		

TEST 5.

0.508	0.020	0.457	0.018	0.1825	0.000283	266	0.564	140	1,990	1	14,000	199,000	Duration of test, 52 seconds; rupture O. K. in upper section.
0.533	0.021	0.432	0.017	0.1805	0.000280	448	0.988	246	3,490	2	12,300	174,500	
						577	1.27	315	4,480	3	10,500	149,000	
						673	1.48	368	5,230	4	9,230	131,000	
						704	1.55	385	5,480	5	7,730	110,000	
						768	1.69	420	6,970	6	7,000	99,500	
						833	1.84	457	6,500	8	5,720	81,300	
						928	2.05	510	7,250	12	4,250	60,400	
						1,055	2.33	573	8,230	17	3,400	48,400	
						1,153	2.54	630	8,970	20	3,150	44,800	
						1,280	2.82	701	9,960	24	2,920	41,500	
						1,376	3.04	754	10,730	26	2,900	41,300	
						1,505	3.32	824	11,730	29	2,840	40,400	
						1,679	3.70	920	13,100	31	2,980	42,200	

TEST 6.

0.381	0.015	0.305	0.012	0.0913	0.000141	228	0.503	251	3,570	1	25,100	357,000	Duration of test, 21 seconds; rupture O. K. in upper section.
0.482	0.019	0.381	0.015	0.1445	0.000224	380	0.839	418	5,950	2	20,900	298,000	
						456	1.01	504	7,170	3	16,800	239,000	
						533	1.18	588	8,370	4	14,700	209,000	
						684	1.51	752	10,700	7	10,800	153,000	
						760	1.68	836	11,900	9	9,280	132,000	
						791	1.74	866	12,340	12	7,240	103,000	

TABLE VII.—Tensile elasticity of single filaments of coir cleaned by machine at the Bureau of Science.

TEST 1.

Cross-sectional dimensions of filament at two places one-third distant from each end of 100 mm. testing length.		Thickness.		Area.		Applied load.		Elongation in 100 mm. testing length.		Modulus of elasticity.		Remarks.
mm.	in.	mm.	in.	Sq. mm.	Sq. in.	lbs.	Kilos per sq. cm.	Pounds per sq. in.	Per cent.	Kilos per sq. cm.	Pounds per sq. in.	
	608					1.34	236	3,350	1	23,600	335,000	Duration of test, 92 seconds; rupture O. K. in lower section.
	896					1.98	348	4,950	2	17,400	247,500	
	1,055					2.33	409	5,825	3	13,600	194,000	
	1,184					2.61	459	6,530	4	11,500	163,000	
	1,248					2.75	483	6,875	5	9,630	137,000	
	1,312					2.89	508	7,230	6	8,440	120,000	
	1,375					3.03	533	7,575	7	7,600	108,000	
	1,440					3.18	559	7,950	8	6,210	88,400	
	1,504					3.32	583	8,300	9	5,830	83,000	
0.762	0.080	0.432	0.019	0.289	0.000448	3.46	608	8,650	10	5,070	72,100	
0.762	0.080	0.431	0.017	0.258	0.000400	3.81	670	9,525	11	4,470	63,500	
	1,920					4.23	745	10,600	12	4,130	58,800	
	2,110					4.65	815	11,600	13	3,890	55,900	
	2,210					4.88	858	12,200	14	3,900	55,400	
	2,305					5.08	893	12,700	15	3,880	55,200	
	2,400					5.29	928	13,200	16	3,850	55,100	
	2,560					5.64	992	14,100	17	3,810	54,200	
	2,690					5.94	1,048	14,900	18	3,850	55,200	
	2,880					6.35	1,117	15,900	19	3,850	54,800	
	2,948					6.50	1,146	16,300	20	5,820	54,300	

TABLE VII.—*Tensile elasticity of single filaments of coir cleaned by machine at the Bureau of Science—Continued.*
TEST 3.

Cross-sectional dimensions of filament at two places one-third distant from each end of the 100 mm. testing length.		Thickness.		Area.		Applied load.				Elongation in 100 mm. testing length.		Modulus of elasticity.		Remarks.
mm.	in.	mm.	in.	Sq. mm.	Sq. in.	lbs.	Kilos per sq. cm.	Pounds per sq. in.	Per cent.	Kilos per sq. cm.	Pounds per sq. in.	Kilos per sq. cm.	Pounds per sq. in.	
0.787	0.081	0.569	0.022	0.345	0.000535	1,922	4.24	557	7.930	16	3,710	52,800	267,000	Duration of test, 105 seconds; rupture O. K. in upper section.
0.837	0.083	0.508	0.020	0.334	0.000518	1,983	4.37	574	8,160	16	3,580	50,900	191,500	
						2,140	4.72	619	8,810	18	3,440	48,900	153,000	
						2,201	4.85	638	9,070	19	3,360	47,700	125,000	
						2,232	5.05	664	9,440	20	3,320	47,200	96,000	
						2,387	5.27	693	9,850	21	3,290	46,800	78,300	
						2,482	5.47	717	10,200	22	3,270	46,400	72,500	
						2,578	5.67	745	10,600	23	3,250	46,200	54,800	
						2,667	5.88	773	11,000	24	3,220	45,800	52,800	
						2,790	6.15	808	11,500	25	3,240	46,000	50,900	
						2,910	6.42	843	12,000	26	3,240	46,100	48,900	
						3,040	6.70	878	12,500	27	3,260	46,300	47,700	
						3,241	7.15	938	13,350	29	3,240	46,100	46,800	

TABLE VII.—Tensile elasticity of single filaments of coir cleaned by machine at the Bureau of Science—Continued.

TEST 5.													
Cross-sectional dimensions of filament at two places one-third distant from each end of the 100 mm. testing length.													
Width.		Thickness.		Area.		Applied load.				Elongation in 100 mm. testing length.	Modulus of elasticity.	Remarks.	
mm.	in.	mm.	in.	Sq. mm.	Sq. in.	g.	lbs.	Kilos per sq. cm.	Pounds per sq. in.				
						330	0.728	163	2,325	1	16,300	232,500	Duration of test, 29 seconds; rupture O. K. in upper section.
						495	1.09	245	3,480	2	12,250	174,000	
						562	1.24	278	3,960	3	9,280	132,000	
						627	1.38	310	4,410	4	7,740	110,000	
0.533	0.021	0.482	0.019	0.202	0.000313	694	1.53	343	4,880	5	6,870	97,700	
0.535	0.025	0.457	0.018	0.226	0.000353	726	1.60	360	5,120	6	6,000	85,300	
						825	1.82	408	5,820	8	5,120	72,700	
						892	1.97	442	6,280	10	4,420	62,800	
						965	2.13	478	6,800	11	4,340	61,800	

TEST 6.													
						165	0.364	197	2,800	1	19,700	290,000	Duration of test, 30 seconds; rupture in upper jaw.
						231	0.510	276	3,920	2	13,800	196,000	
						330	0.728	394	5,600	6	6,560	93,300	
						396	0.874	473	6,720	11	4,280	61,000	
						495	1.09	589	8,380	19	3,100	44,100	
						628	1.38	748	10,600	25	2,950	42,400	
						760	1.68	906	12,900	29	3,130	44,500	
0.381	0.015	0.279	0.011	0.0838	0.000130	858	1.89	1,020	14,500	31	3,290	46,800	
0.381	0.015	0.279	0.011	0.0838	0.000130	958	2.11	1,140	16,200	34	3,360	47,700	
						1,006	2.22	1,200	17,100	35	3,430	48,800	

TABLE VIII.—Tensile elasticity of one abacá filament (grade "F," from Mindanao) 1.350 millimeters long, tested in nine 150-millimeter lengths in their natural order, beginning at the base and ending at the tip of the filament.

FIRST 150-MILLIMETER LENGTH.																
Cross-sectional dimensions of filament at two places one-third distant from each end of the 100 mm. testing length.																
Width.			Thickness.			Area.			Applied load.			Elongation in 100 mm.		Modulus of elasticity.		Remarks.
mm.	in.	mm.	in.	Sq. mm.	Sq. in.	g.	lbs.	Kilos per sq. cm.	Pounds per sq. in.	Per cent.	Kilos per sq. cm.	Pounds per sq. in.				
0.381	0.015	0.208	0.008	0.0608	0.000943	1,298	2.85	2,130	30,250	2	108,400	1,512,000				
0.406	0.016	0.178	0.007	0.0560	0.000868	1,530	3.37	2,510	35,950	2.5	100,500	1,430,000				
						1,770	3.91	2,980	42,400	3	99,300	1,410,000				
						2,040	4.50	3,360	47,800	3.5	96,000	1,365,000				
						2,280	5.03	3,750	53,400	4	93,700	1,330,000				
Duration of test, 68 seconds; rupture O. K. in upper section.																
SECOND 150-MILLIMETER LENGTH.																
403	0.888	875	12,440	0.5	175,000	2,490,000										
745	1.64	1,616	22,950	1	161,600	2,295,000										
1,024	2.26	2,225	31,650	1.5	148,300	2,110,000										
1,366	3.01	2,965	42,200	2	143,300	2,110,000										
1,613	3.54	3,490	49,600	2.5	139,500	1,984,000										
1,923	4.24	4,170	59,400	3	139,300	1,980,000										
2,200	4.85	4,775	67,900	3.5	136,500	1,940,000										
2,450	5.40	5,320	75,700	4	133,000	1,890,000										
2,764	6.09	6,000	85,300	4.5	133,000	1,895,000										
Duration of test, 88 seconds; rupture in lower jaw.																

TABLE VIII.—Tensile elasticity of one abacá filament (grade "F," from Mindanao) 1,350 millimeters long, etc.—Continued.

THIRD 150-MILLIMETER LENGTH.													
Cross-sectional dimensions of filament at two places one-third distant from each end of the 100 mm. testing length.				Area.		Applied load.				Elongation in 100 mm.	Modulus of elasticity.	Remarks.	
Width.		Thickness.		Area.		lbs.		Pounds per sq. in.		Per cent.	Kilos per sq. cm.	Pounds per sq. in.	
mm.	in.	mm.	in.	Sq. mm.	Sq. in.	g.	lbs.	Kilos per sq. in.	Pounds per sq. in.				
0.330	0.013	0.178	0.007	0.0461	0.0000714	2,492	5.49	7,570	107,600	4	189,300	2,690,000	Elongation at point of rupture taken only; stop watch snapped too late. Break O. K. in lower section.
0.330	0.013	0.127	0.005	0.0329	0.0000510								
FOURTH 150-MILLIMETER LENGTH.													
0.254	0.010	0.152	0.006	0.0304	0.0000471	384	0.847	1,280	17,970	0.5	253,000	3,595,000	Duration of test, 86 seconds; rupture O. K. in upper section.
						768	1.69	2,525	35,900	1	252,500	3,590,000	
0.305	0.012	0.178	0.007	0.0425	0.0000559	1,152	7.54	3,790	53,900	1.5	253,000	3,595,000	
						1,473	3.25	4,850	69,000	2	243,000	3,450,000	
						1,857	4.10	6,190	88,100	2.5	245,000	3,480,000	
						2,240	4.94	7,375	104,900	3	246,000	3,495,000	
						2,590	5.72	8,550	121,500	3.5	244,000	3,470,000	
						2,731	6.02	8,990	127,800	b 3.72	a 244,000	a 3,470,000	

TABLE VIII.—Tensile elasticity of one abacá filament (grade "F," from Mindanao) 1.50 millimeters long, etc.—Continued.

Width.				Thickness.		Area.		Applied load.				Elongation in 100 mm.	Modulus of elasticity.		Remarks.
mm.	in.	mm.	in.	mm.	in.	Sq. mm.	Sq. in.	g.	lbs.	Kilos per sq. cm.	Pounds per sq. in.	Per cent.	Kilos per sq. cm.	Pounds per sq. in.	
0.203	0.008	0.162	0.006	0.0243	0.000377			256	0.565	1,124	15,990	0.5	225,000	3,195,000	Duration of test, 52 seconds; rupture O. K. in lower section.
0.229	0.009	0.127	0.005	0.0228	0.000353			544	1.20	2,390	34,000	1	239,000	3,400,000	
								832	1.83	3,640	51,800	1.5	243,000	3,450,000	
								1,120	2.47	4,920	70,000	2	246,000	3,600,000	
								1,565	3.82	6,610	94,000	2.5	264,000	3,760,000	
								1,670	3.68	7,310	104,000	2.77	264,000	3,760,000	
NINTH 150-MILLIMETER LENGTH.															
0.229	0.009	0.102	0.004	0.0185	0.000283			360	0.794	1,970	28,050	0.5	394,000	5,600,000	Duration of test, 52 seconds; rupture O. K. in upper section.
0.203	0.008	0.127	0.005	0.0203	0.000314			680	1.52	3,780	53,750	1	378,000	5,375,000	
								1,020	2.05	5,090	72,400	1.5	393,000	4,825,000	
								1,290	2.84	7,040	100,300	2	352,000	5,025,000	
								1,563	3.45	8,570	121,700	2.5	343,000	4,875,000	

* Assumed modulus. b Calculated from the assumed modulus.

The moduli of tensile elasticity, E , were computed from the data given in columns 9, 10, and 11, Tables VI, VII, and VIII. The notations used are:

S =Stress in kilograms per square centimeter or in pounds per square inch.

L =Gauged length of the filament (100 millimeters).

l =Elongation in millimeters.

E =Modulus of tensile elasticity in either kilograms per square centimeter or pounds per square inch.

$$E = \frac{S}{l/L} \quad \text{or} \quad E = \frac{S \times L}{l}$$

The typical tests as recorded in Table VIII show that abacá filaments are almost perfectly elastic up to the point of rupture, at a stress often as high as 8,000 kilograms per square centimeter, as shown by the modulus of elasticity.

Fig. 2 shows the stress-deformation graphs of an abacá 150-millimeter filament section, grade "F" fiber, taken at random and of a single filament No. 4 of machine-cleaned coir, which has the greatest elasticity of any coir specimen tested. If a filament has no elasticity, the stress-deformation graph will be a curved line from the beginning of tension to the point of rupture; on the other hand, if a filament has perfect elasticity, the graph will be represented by a straight line. It will be noted that the linear relationship between stress and deformation in the abacá filament section is practically ideal, as shown by the straight line in the graph, which persists to the point of rupture; while the data on the coir specimen give a stress-deformation graph having a very short, initial, straight-line portion. This indicates that there was perfect elasticity where the stress and deformation for a short period at the outset were directly proportional as shown on the graph between 0 and 308 kilograms per square centimeter. In other words, the straight portion of this graph shows that the filament would spring back to its original shape and length if it were unloaded at the point corresponding to the stress of 308 kilograms per square centimeter and the elongation of 2 millimeters. When stressed beyond 308 kilograms per square centimeter the filament begins to elongate rapidly, but the corresponding stress does not increase at the same rate; and, if the load is removed, the filament will no longer return to its original length, because it has become permanently set. Filament No. 4 is typical of only very coarse filaments already classified as brush or bristle fiber rather than as cordage fiber.

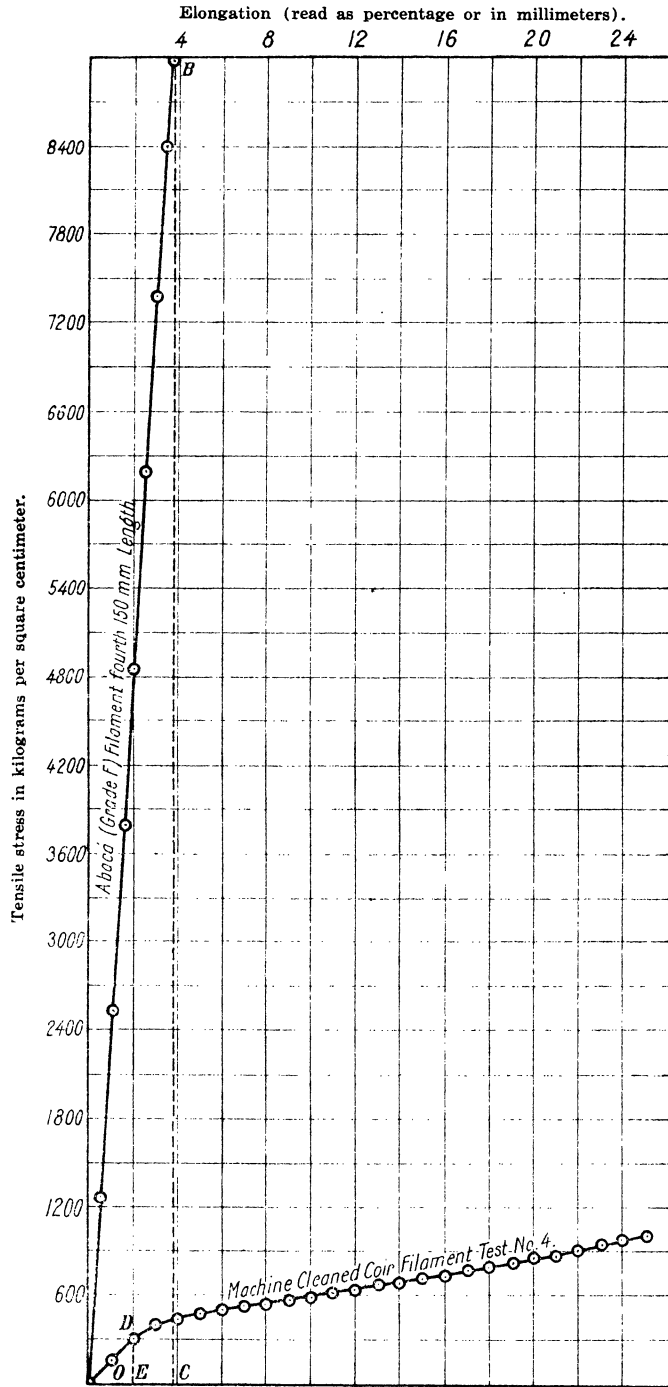

FIG. 2. Comparative stress-deformation graphs of abaca and coir filaments, showing the relative elasticity and resilience.

The stress-deformation graphs of coir shown in fig. 3 are all curved; that is, the value of E decreases rapidly after the first millimeter of elongation. From this it may be seen that coir belongs to the class of materials in which stress and deformation while in tension are not directly proportional, and that even the smallest stress permanently injures the fibers. Therefore, for all practical purposes, coir is not distinguishably elastic, nor has it a definite modulus of elasticity. Its lack of elasticity, together with its comparatively low strength, condemn it for use in cordage except of an inferior quality. These facts are entirely at variance with the claims of "highly elastic properties" for coir as discussed in preceding pages.

The only coir filament that gave an elastic modulus within a definitely measurable range is that of which a graph is shown in fig. 2. Assuming that coir has a definite elastic modulus for immeasurably small deformations, the maximum value that can be assigned is 27,000 kilograms per square centimeter obtained in test 2 of the machine-cleaned fiber, which in this maximum case is only one-fifteenth of the maximum value for abacá.

Resilience.—Elasticity is intimately connected with resilience, or "jerk-resisting power," inasmuch as the latter depends largely upon the former. Resilience is the springing back of a deformed body after being relieved of the deforming load, it being always understood that the stress must be within the elastic limit. It is usually measured in kilogram-meters or in foot-pounds, though smaller units such as kilogram-centimeters or inch-pounds are sometimes used. It should be borne in mind that the energy expended in permanently deforming a body cannot be given back as resilient work, but appears as heat, and is used to break down the structure.

Johnson³⁸ says:

* * * *the resilience, or energy, which can be absorbed, or stored, in a body of a given material and form, up to a given fibre-stress, is no function of the relative dimensions of the body, but only of its volume.*

The method of calculating resilience is very simple. If the initial force of tension of coir is zero, and the final one at the limit of elasticity is 308 kilograms per square centimeter as obtained in my test for machine-cleaned filament No. 4, the value of the average stress is 154 kilograms per square centimeter. The elongation of the test specimen at the limit of elasticity is 2 millimeters; then, since the average stress of 154

³⁸ Johnson, J. B., *Materials of Construction*. John Wiley and Son, New York, 4th ed. (1912), 76.

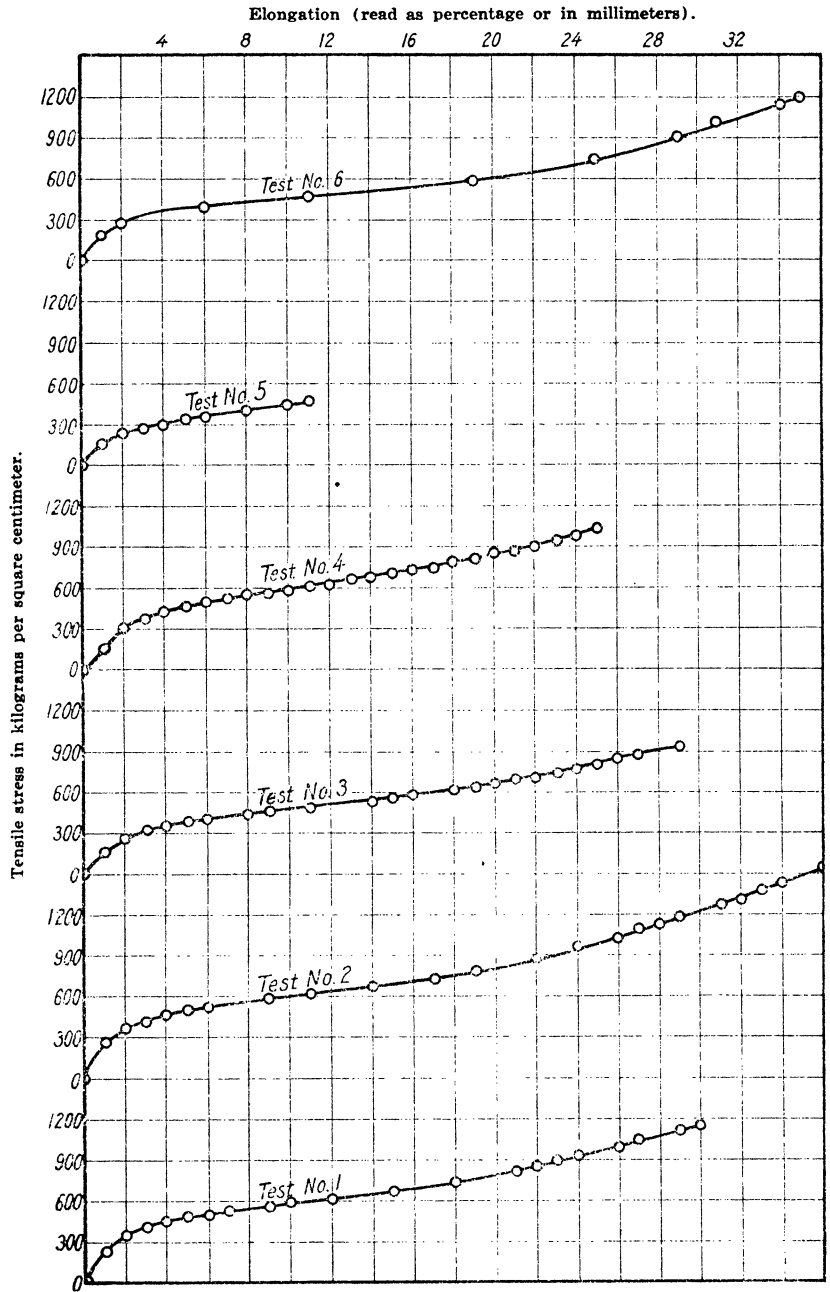

FIG. 3. Stress-deformation graphs of single, machine-cleaned, coir filaments; values taken from Table VII.

kilograms per square centimeter has acted through a distance of 2 millimeters, the work done in stretching to its elastic limit a coir specimen having a sectional area of 1 square centimeter and a length of 100 millimeters is equal to $154 \times 0.2 = 30.8$ kilogram-centimeters, which is the resilient energy stored in 10 cubic centimeters of the sample. In this form the resilience of coir can be compared with that of other materials.

When graphs have been prepared, the elastic resilience may be calculated, with due regard to the scale employed, from the area of the right-angled triangle *ODE* (fig. 2) formed by the straight line of the stress-deformation graph, the abscissa, and the perpendicular to the latter from the elastic limit. The comparative resilience of coir and abacá filaments is plainly shown by the relative area of the two triangles *ODE*, and *OBC*, fig. 2.

It has already been indicated that most of the coir filaments tested have no definite elastic limit or elastic modulus and that, except with the first application of tension when work is spent in deforming the specimen, they have little shock- or jerk-resisting properties. Coir has practically no elastic resilience, and the greater part of the tensional deformation of the filaments is permanent. These deductions are confirmed by the results of tensile experiments recorded in Table IX. In these experiments test specimens were loaded at a constant rate to various degrees of stress and the load allowed to remain constant for five minutes. At the end of the five minutes, each specimen had elongated considerably more than its initial elongation, the extension being represented by 5, 12, and 18, and 2, 6, and 10 per cent, respectively. The load was then removed and it will be noted that, at the end of one minute's rest, the specimens in no case recovered any of their initial elongation, as shown by the permanent set of 2, 7, and 11 per cent (or millimeters), respectively.

As shown in Table IX abacá filaments, loaded to relatively much higher stresses than coir, recovered completely after removal of the load. The tests show that abacá has the property of potentially storing comparatively large quantities of elastic energy, these being returned in the form of useful work when the load is removed. This indicates the origin of the expression "give and take" which in common parlance is used to designate the valuable property of resilience possessed to so high a degree by the best grades of abacá cordage. The average resilience stored in 10 cubic centimeters of grade "F" abacá is 1,281 kilogram-centimeters, which is forty-one times as much as that

TABLE IX.—Tensile experiments on coir and abacá filaments to determine permanent set.

COIR; TEST 1.

Cross-sectional dimensions of filament at two places one-third distant from each end of the 100 mm. gauged length.				Applied load.				Elongation.			Remarks.		
Width.		Thickness.		Area.		σ.	lbs.	Kilos per sq. cm.	Founds per sq. in.	Immediately after loading.		After being loaded for 5 minutes.	At breaking load.
mm.	in.	mm.	in.	Sq. mm.	Sq. in.								
0.685	0.027	0.431	0.017	0.234	0.000363	1,483	3.27	982	13,240	10	18	27	Permanently set; no recovery from initial elongation. Breaking load; rupture O. K.
0.633	0.021	0.381	0.015	0.159	0.000247	2,372	5.23	1,490	21,150				

COIR; TEST 2.

0.686	0.027	0.457	0.018	0.246	0.000381	953	2.10	413	5,870	6	12	24	Permanently set; no recovery from initial elongation. Breaking load; rupture O. K.
0.609	0.024	0.482	0.019	0.231	0.000358	1,640	3.62	710	10,100				

COIR; TEST 3.

0.609	0.024	0.457	0.018	0.219	0.000359	665	1.47	564	8,030	2	5	32	Permanently set; no recovery from initial elongation. Breaking load; rupture O. K.
0.609	0.024	0.381	0.015	0.183	0.000283	1,995	4.40	1,093	15,550				

"E" GRADE ABACA; TEST 1.

0.406	0.016	0.203	0.008	0.0648	0.0001005	2,501	5.52	386	54,900	2	2	3.5	0	Complete recovery; perfectly elastic; highly resilient. Breaking load; rupture O. K.
0.406	0.016	0.203	0.008	0.0648	0.0001005	4,105	9.05	6,330	90,000					

"E" GRADE ABACA; TEST 2.

0.381	0.015	0.203	0.008	0.0608	0.0000942	2,558	5.64	420	59,800	2	2	3	0	Complete recovery after removal of load; highly elastic and resilient. Breaking load; rupture O. K.
0.381	0.015	0.208	0.008	0.0608	0.0000942	4,140	9.14	6,820	97,000					

"E" GRADE ABACA; TEST 3.

0.355	0.014	0.203	0.008	0.0567	0.0000879	2,513	5.54	448	63,000	2	2	2.5	0	Complete recovery after removal of load; highly resilient and elastic. Breaking load; rupture O. K.
0.355	0.014	0.203	0.008	0.0567	0.0000879	3,083	6.80	5,430	77,300					

* Increased length of specimen after removal of load and resting 1 minute.

for the most resilient coir filament. This high resilience and elasticity, coupled with its extraordinary tensile strength, are the chief factors in accounting for the fact that abacá is considered the premier cordage fiber of the world.

A COMPARISON OF THE MECHANICAL PROPERTIES OF COIR AND
ABACÁ (MANILA HEMP) ROPES

Three handmade, three-strand coir ropes of different sizes were tested. Two of these made of coir from Laguna husks, machine-cleaned at the Bureau of Science, had circumferences of 24 and 44 millimeters, respectively. The other was a retted coir rope 50 millimeters in circumference obtained from Caoayan, Ilocos Sur. The machine-cleaned fiber was spun by hand into strands at the Bureau of Science, and the Bureau of Agriculture had the spun fiber laid into two ropes at a Pasig ropewalk. The rope had the ragged, rough appearance, due to the numerous protruding filament ends, that is characteristic of untrimmed coir rope, whether hand or machine laid.

The abacá specimens consisted of four sizes of Government inspected, pure "F" and "G" grades, three-strand rope, 15, 16, 26, and 31 millimeters in circumference, respectively. The ropes were machine laid with about 10 per cent of mineral oil added to the fiber during manufacture for lubricating purposes, and for its ultimate preservation. The test specimens of both abacá and coir were prepared with eye-splices at the ends. The distance between splices was either 50 or 100 centimeters as shown in each case in the table. Each eye and splice measured about 15 centimeters in length. Three tucks were made in each splice, and the internal diameter of the eyes was 4.5 centimeters.

Circumference and diameter.—The measurements of the average actual girth, or perimeter, of the ropes given in Tables XI, XII, XIII, and XIV were obtained by encircling each test specimen with a strip of tough linen paper about 2 millimeters wide and marking it with a very sharp pencil at a convenient overlapping point. The strip was then straightened and measured on a scale graduated in millimeters. As the irregular nature of the cordage introduced appreciable variation in size, the readings were taken to the nearest whole millimeter. The girth obtained in this manner is less than the internal circumference of a ring through which the specimen will just pass; but numerous measurements show that for small ropes the difference is so slight that the girth has been considered adequately approximate to the true circumference of the rope.

Fig. 4 shows actual profiles of transverse sections of the 50-millimeter coir rope taken at nine different places, at intervals of 2 centimeters. The diameter of a rope is equal to the diameter of the circular opening through which the specimen will just pass and, theoretically at least, forms the basis of other cross-sectional dimensions. Although the circumscribing circumference is the true circumference of the ropé and its diameter that of the specimen, the position taken by the paper strip used for measuring the girth of the rope represented by line *b*, is an approximation of the true circumference. To obtain the girth is an easy matter, whereas to obtain the true circumference, especially with unskilled labor, involves greater un-

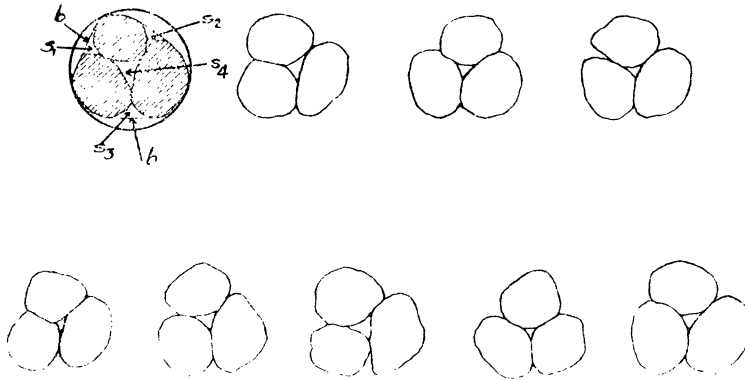

FIG. 4. Sectional profiles of 50-millimeter coir ropes. Actual size.

certainties and requires numerous circular gauges with graded apertures. Therefore, the diameters given in Tables XI, XII, XIII, and XIV have been calculated by assigning the length of the line *b-b* (the actual girth) to a circumference, and the diameter of this has been taken as the diameter of the rope.

Area.—What is meant by the area of the transverse section of a rope is usually very indefinite. Unless information is given as to how it is obtained, this dimension has little significance, and values based on it are untrustworthy. In fig. 4 the sum of the areas representing the strands of a rope is less than the area encompassed by the actual girth, and still less than the area within the circumference. The values approach each other as the size of the rope diminishes and, for small ropes of 50 millimeters girth, the area calculated by assigning the actual girth measurement to a circumference will average 15

per cent larger than the true transverse area of the rope represented in fig. 4 by the cross-hatched area.³⁸ The latter area is a close approximation of the actual solid fiber area, but still does not take into consideration the void spaces between the individual filaments constituting each strand. These smaller void spaces depend upon the size and shape of the fiber; its cleanliness; the method of manufacture; the degree of twist; the presence or absence of grease, fat, oil, or adulterant, etc. No attempt was made in this work to determine the actual void space within the strands.

In order to determine the true transverse cross section of the rope specimens, pieces of rope about 15 centimeters long were soaked for about five minutes in melted paraffin heated to about 90° C., until most of the bubbles of entrapped air had escaped, when the pieces were placed in test tubes which were then filled with paraffin. Effort was made to avoid swelling the rope. When the paraffin was solidified the tubes were cooled in tap water and the glass broken off. The rope, which was now firmly embedded in paraffin, was carefully cut by hand at right angles to the longitudinal axis into sections 2 centimeters long by means of a heavy razor. Each 2-centimeter section gave two very clear profiles, which were brought into sharp contrast by marking the boundary of the strands with India ink. Each profile was then copied on tracing paper; a few of these profiles are illustrated in fig. 4. The tracings of the outlines were carefully and accurately cut out giving three irregular pieces of paper showing the exact contours of the three rope strands, and necessarily having the same areas as the rope sections. The paper profiles were then weighed on a Heusser button balance, sensitive to 0.002 milligram, and compared with the weight of 1-centimeter paper disks, obtained adjacent to the profiles, having an area of 78.54 square millimeters. For cutting the disks, a bow compass with a keen tool-steel cutter was used in place of the usual graphite style. From the averages of these data the areas of the irregular rope sections were calculated. In order to show the accuracy that may be attained by this method the data for the 50-millimeter coir rope from Ilocos Sur are given in Table X.

³⁸ The relative magnitude of areas computed by the two methods is being further studied in conjunction with the mechanical properties of Philippine bast-fiber cordage.

TABLE X.—*Comparative weights of paper profiles of coir rope, 50 millimeters in circumference, and paper disks 1 centimeter in diameter.*

[Weights of paper in grams.]	
Profiles.	Disks.
0.00962	0.00419
0.00913	0.00436
0.00932	0.00463
0.00893	0.00441
0.00856	0.00457
0.00864	0.00433
0.00888	0.00444
0.00921	0.00449
0.00902	0.00447
0.00931	0.00444
.....	0.00465
0.00906 ^a	0.00445 ^a

^a Mean.

The average area of the rope section is equal to

$$\frac{0.00906}{0.00445} \times 78.54 \text{ square millimeters} = 159.8 \text{ square millimeters.}$$

The values thus obtained for the various ropes closely approximate the actual transverse areas of the ropes. This true mean area was used in making the calculations of the ultimate tensile strength per unit area of the ropes as given in Table XI.

Many commercial tests of ropes are intended to be comparable only; therefore, the transverse cross section need not be the actual but only the relative measurement. In the comparison of ropes of the same numerical size the transverse cross sections if determined by the same method are relative, whether the method employed be the ring method, the girth method, the strand-area method, or the absolute-area method. However, it must be borne in mind that many published data of rope areas, while accurate for the purposes they are intended to serve, are not at all comparable with one another; and they should not be compared unless the method of determining the transverse cross section is given and the same method was used in obtaining the results to be compared.

Breaking length.—Due to the difficulty involved in measuring the cross-sectional area of ropes, fibers, and yarns, it is more convenient to compare their strength by means of the so-called “breaking length” instead of the strength per unit area. The breaking length of a rope is the length which a specimen must have to break of its own weight when suspended at one end. It is computed by dividing the ultimate breaking load in kilo-

grams or pounds by the corresponding weight of the rope in kilograms per meter or pounds per foot. The measurement and the computation of difficult areas are not necessary and it is, therefore, frequently used in testing fibers and fiber products.

Testing machines for determining elongation and tensile strength.—The two larger rope specimens were ruptured in a direct, motor-driven, 30,000 pounds capacity, four-screw, automatic testing machine, manufactured by Tinius Olsen, of Philadelphia, Pennsylvania. This testing machine is of the screw-gear and lever type and is graduated to read five-pound intervals. The smallest rope specimens were tested in a Riehlé Bros. (Philadelphia, Pa.) tension-testing machine of the elastic resistor or helical spring type, having a capacity of 600 pounds, graduated to read one-pound intervals. This machine is hand operated by means of a fairly heavy crank-driven flywheel. Both testing machines were compared and found to agree within the limit of the sensibility of the larger machine. The variation in the strength of the rope was much greater than any possible error in either of the testing machines.

Elongation.—Each test specimen was held vertically in the testing machine by smooth steel pins that passed through the eyes formed at the ends of the test piece, and was subjected to a small preliminary tension not exceeding 5 pounds. Two points, 50 or 100 centimeters apart, were clearly marked on it with chalk or pencil. A scale graduated in millimeters was used for measuring the gauge-length. The load was then applied at the uniform rate of 1.3 millimeters' stretch per second. During the time the load was being applied, the elongation was carefully noted on the scale. The total distance between the index marks at the instant of rupture was noted. The difference between this distance and the gauge-length gave the elongation in centimeters. The elongation readings could not be measured with an accuracy greater than 0.5 centimeter in 50 centimeters; therefore, the average elongations are given only in whole percentages. Table XI shows that coir rope has a slightly greater average elongation than the individual coir filaments as given in Tables VI and VII, whereas abacá rope has several times the elongation of the individual abacá filaments as given in Table VIII.

Tensile-strength tests.—The specimens of coir and abacá were tested air dry, and after exposure to fresh water, to salt water, and to weather, as indicated in Tables XI, XII, XIII, and XIV, respectively. The machines used in this work have already been

described. The test pieces in Table XIV were exposed to usual weather conditions for ninety days (from April 26 to July 25, 1918), on the black-painted, galvanized-iron, laboratory roof, before being subjected to the tensile-strength test. The detailed character of the weather is given by the Weather Bureau.³⁹ During the first month of exposure the weather was clear. In the second month there were frequent light rains in the afternoon, but during the morning the weather was usually so clear that the test specimens quickly dried. This alternate wetting and drying subjected the fiber to a severe test. The third month of exposure was characterized by two periods of stormy weather and heavy precipitation.

Although the number of experiments conducted is small and the relative duration of the exposure was short, nevertheless, the tensile-strength tests of coir and abacá recorded in Tables XI, XII, XIII, and XIV show that rope made from coir is more susceptible to the destructive influences of fresh or salt water as well as of atmospheric agencies than rope made from either "F" or "G" grade abacá fiber.

The low tensile strength per unit area, the high elongation, and the small breaking length of the coir specimens are evident from Table XI. The rope made from the weaker retted fiber gives a slightly higher ultimate resistance per square centimeter than that made from the stronger machine-cleaned fiber. However, the difference in their comparative strengths is so small as to be of little significance. The results in all three tests emphasize the extreme weakness of coir rope. Abacá rope is, roughly, five times as strong per unit area as coir rope and has a breaking length approximately three times as great.

Table XII shows that submergence in fresh water for twenty-four hours slightly increased the elongation and decreased the tensile strength of coir rope. The decrease was greater in the rope made of retted fiber than in that made of machine-cleaned fiber. The loss in strength of the rope made of machine-cleaned fiber is not much more after immersion for twenty-one days in stagnant tap water than after twenty-four hours. There is little change in the strength of the abacá-rope specimens tested.

Salt water seems to decrease the tensile strength of both coir and abacá ropes slightly more than does fresh water, as shown in Table XIII.

Table XIV indicates that coir rope loses in tensile strength

³⁹ *Ann. Rep. P. I. Weather Bureau (1918).*

TABLE XI.—Tensile-strength tests of Philippine coir and abacá, three-strand ropes in their natural air-dry condition.

Average girth or perimeter of rope.	Average weight per unit length.		Average diameter of rope. ^a		True mean area of transverse rope section.		Average area of rope section. ^b		Average elongation.	Average breaking load.		Average ultimate tensile strength.		Average breaking length.			
	Pounds per ft.	Grams per m.	mm.	in.	Sq. mm.	Sq. in.	Sq. mm.	Sq. in.		Kilos.	Pounds.	Kilos per sq. cm.	Pounds per sq. in.		Meters.	Feet.	
mm. in.																	
Coir rope from Ilocos Sur made of retted fiber.	50	1.97	0.0756	112.5	15.9	0.63	169.8	0.247	198.6	0.308	4.36	295	651	186	2,640	2,620	8,610
Coir rope made of machine-cleaned fiber obtained from Laguna huaks ^c .	44	1.73	0.0548	81.5	14.0	0.55	131	0.203	153.9	0.239	4.39	222	490	170	2,420	2,730	8,950
	24	0.95	0.0130	19.4	7.6	0.30	33.9	0.060	46.3	0.071	4.30	68.8	152	176	2,490	3,550	11,650
Rope made from "F" grade abacá ^d .	31	1.22	0.0395	58.8	9.9	0.39	76.9	0.119	76.5	0.119	4.13	724	1,596	943	13,400	12,300	40,400
	16	0.59	0.0085	12.7	4.8	0.19	15.5	0.024	18	0.028	4.18	151	333	974	13,800	11,900	39,000
Rope made of "G" grade abacá ^e .	26	1.02	0.0319	47.5	8.3	0.33	53.5	0.083	54.1	0.084	4.16	398	878	744	10,600	8,390	27,500
	16	0.63	0.0104	15.4	5.1	0.20	14.1	0.022	20.4	0.032	4.13	157	345	1,110	15,700	10,200	33,300

^a Based on a circle having a circumference equivalent to girth.

^b Based on the area of a circle having a circumference equivalent to girth.

^c These results are the average of seven individual specimens.

^d Gauge length, 100 centimeters.

^e These results are the average of ten individual specimens of the 44-millimeter rope and seven individual specimens of the 24-millimeter rope.

^f Gauge length, 50 centimeters.

^g These results are the average of sixteen individual specimens, eight for each size of rope.

TABLE XII.—Tensile-strength tests of Philippine coir and abacá, three-strand ropes after twenty-four hours' immersion in tap water.

	Average diameter of rope based on a circle girth, or perimeter, of having a circumference equal to girth.		True mean area of transverse section of rope.		Average elongation.	Actual average breaking load.	Ultimate tensile strength.		Change in strength of rope, as compared with the original sample.			
	mm.	in.	mm.	sq. in.			Kilos. per sq. cm.	Pounds per sq. in.				
										mm.	sq. in.	Per cent.
Rope from Ilcos Sur, made of retted fiber ^a	50	1.97	15.9	0.63	159.5	0.247	b 38	217	479	136	1,940	26 per cent loss.
Rope made of machine-cleaned fiber from Laguna husks ^c	44	1.73	14.0	0.55	131	0.203	c 42	191	420	146	2,070	14 per cent loss.
Rope made of "F" grade abacá ^d	24	0.95	7.6	0.30	38.9	0.060	e 32	457.6	1,127	148	2,100	16 per cent loss.
	31	1.22	9.9	0.39	76.9	0.119	b 18	727	1,604	946	13,500	No change.
	15	0.59	4.8	0.19	15.5	0.024	c 12	143	316	923	13,100	5 per cent loss.
	26	1.02	8.3	0.33	53.5	0.083	b 19	406	896	759	10,800	2 per cent increase.
Rope made of "G" grade abacá ^f	16	0.63	5.1	0.20	14.1	0.022	e 15	166	366	1,180	16,700	6 per cent increase.

^a These results are the average of four specimens.

^b Gauge length, 100 centimeters.

^c Gauge length, 50 centimeters.

^d Average strength of six samples after having been immersed in stagnant tap water at room temperature twenty-one days.

^e These results are the average of four specimens.

^f These results are the average of sixteen specimens.

TABLE XIII.—Tensile-strength tests of coir and abacá, three-strand ropes after four days' immersion in the salt water of Manila Bay.

	Average girth, or perimeter, of rope.		Average diameter of rope based on a circle having a circumference equal to girth of rope.		True mean area of transverse section of rope.	Average elongation, %	Average breaking load.		Average ultimate tensile strength.		Loss in strength.
	mm.	in.	mm.	in.			Kilos.	Pounds.	Kilos per sq. cm.	Pounds per sq. in.	
Rope made of machine-cleaned fiber from Laguna huaks ^b	44	1.73	16.9	0.63	131	0.203	175	885	134	1,900	21
Rope made from "G" grade abacá ^c	16	0.63	5.1	0.20	14.1	0.022	148	327	1,050	14,900	5
Rope made from "F" grade abacá ^b	15	0.59	4.8	0.19	15.5	0.024	128	283	826	11,800	15

^a Gauge length, 50 centimeters.

^b These results are the average of five specimens.

^c These results are the average of six specimens.

much more rapidly under ordinary conditions of weather than does abacá rope.

In order to give a general idea of the tensile strength of commercial abacá rope, I have summarized in Table XV the routine tests made in the Bureau of Science. Little information is available other than the size and actual breaking strength of many of the specimens. The purity of the fiber has not been determined, and it seems probable that some of the samples may have been adulterated with maguey and other abacá substitutes. However, the results indicate what may be expected of commercial abacá ropes.

GENERAL

About fifteen years ago, machine-laid coir rope imported from India was given a five years' trial by a local construction concern. It was recommended on account of its reputed light weight, durability, and the fact that it floats. The latter was believed to be an especially important consideration for tow lines, as those of abacá submerge when in use. The cordage was principally of the larger sizes and was used for towing and mooring barges with a displacement ranging from 50 to 800 tons. Experience has amply shown that such rope when slightly worn could not stand the loads to which it was subjected. It frequently happened that moored barges in surging back and forth would snap their cables, or hawsers, thereby imperiling the safety of valuable property. The use of coir rope finally had to be abandoned in spite of its relatively low price, because it was weak and unreliable.

Another report of a trial of machine-laid coir rope was that it suffered gradual reduction in diameter and increase in length. The results given in this paper, showing not only the extremely low elasticity and resilience of coir, but also the tendency of the fiber once it becomes stretched to remain so instead of springing back to its original length after removal of the load, easily explain the gradual thinning of the rope. Every additional load stretches the fiber more and more, its diameter decreasing correspondingly. It may be also that the filaments, being short, develop insufficient friction between them by the twist, and that part of the permanent elongation may be due to the filaments slipping past each other.

In Ilocos Sur coir cordage was discussed with several Filipinos engaged in the coastwise trade. By experience they have found that local handmade coir ropes, though weak, are adequate to meet the demands imposed by the small sailing craft. On the other hand, several sailing vessels that were moored with

TABLE XIV.—Tensile-strength tests of coir and abacá rope immersed four days in Manila Bay and exposed ninety days to the weather. The ropes were air dry at the time of the tests.

	Average diameter of rope based on circle girth, or perimeter, of circumference of rope.		True mean area of transverse rope section.		Average elongation. ^a	Average breaking load.		Average ultimate tensile strength.		Average breaking length.		Loss in strength.		
	mm.	in.	Sq. mm.	Sq. in.		Kilos.	Pounds.	Kilos per sq. cm.	Pounds per sq. in.	Meters.	Feet.		Per cent.	
Coir rope made of machine-cleaned fiber obtained from Laguna husks ^b	44	1.73	14	0.55	131	0.203	34	144	318	110	1,570	1,770	5,800	35
Rope made of "G" grade abacá ^c	26	1.02	8.3	0.33	53.5	0.083	18	358	790	670	9,520	7,540	24,800	10
Rope made of "P" grade abacá ^d	31	1.22	9.9	0.39	76.9	0.119	17	658	1,448	856	12,200	11,200	36,700	9

^a Gauge length, 50 centimeters.

^b These results are the mean of those for two specimens which gave 355 and 280 pounds breaking load, respectively.

^c These results are the mean of five specimens.

^d These results are the mean of six specimens.

coir ropes broke their moorings during severe tropical storms and were carried high on the beach. As a result the Filipinos have learned that, while coir and other cheap ropes made of maguey, bamboo, etc., may serve for everyday use, abacá rope is the most dependable for emergencies.

Mr. Don Strong, fiber expert of the Bureau of Agriculture, relates that in 1912 the small steamer *Camiguin*, 53 tons gross, ran on a coral reef off the Masbate coast while loaded with abacá fiber. Mr. Strong, who was on board, secured the assistance of a lighthouse tender, whose captain first passed a new 12-inch coir rope to the *Camiguin*. An attempt was made to pull off the steamer, with the result that the coir rope began to stretch excessively, visibly became reduced in diameter, and finally parted at several places. During the attempt not the slightest tremor passed through the reef-bound vessel. A 7-inch abacá rope was then made fast to the *Camiguin* and after a single attempt the steamer was successfully pulled off the reef into deep water.

When a coir rope breaks there is very little reaction, for the rupture occurs almost imperceptibly. On the other hand, an abacá rope made of good grade fiber gives a sharp report at the instant of rupture and violent reaction occurs which, in the case of ropes having a circumference of 75 millimeters or more, jars and shakes the testing machines. This violent reaction is due to the giving back of a relatively large amount of potentially stored resilient energy. Coir is not used at all in Manila at the present time, due to the unsatisfactory results that have been obtained. Cordage made of abacá, of which there are numerous grades, has supplanted the little coir that was once used. Even though abacá rope costs considerably more than coir cordage, the more expensive fiber is the more economical in the end. Abacá is much stronger, less bulky, more reliable, and much more elastic and resilient than coir. I have inquired for coir cordage in several places in Manila, but was unable to get quotations or even to see a specimen. Even the small Chinese retailers who handle the most unexpected kinds of merchandise did not have supplies of coir rope, though other nonstandard fiber cordage was procurable. Among the latter, small coils of rope made of the black stiff fiber locally called "cabo negro," obtained from a palm (*Arenga saccharifera*), were on sale in nearly all of the Chinese stores dealing in fiber products. Unless the difference in price of coir and abacá rope is large enough to create a demand for the former on the basis of price alone, coir cordage will never find extensive sale.

TABLE XV.—Tensile-strength tests of 1-meter lengths of three-strand machine-laid, abacá rope from various Manila factories.*

Grade.	Circumference.			Average diameter, based on circle having a circumference equal to girth.		Weight per unit length.		Elongation.	Breaking length.		Breaking load.		Remarks.	
	Actual average girth.		As labeled when received for testing.	mm.	in.	Kilos per meter.	Pounds per ft.		Per cent.	Meters.	Feet.	Kilos.		Pounds.
	mm.	in.	mm.											
	26	1.02	25	1	8.3	0.32	0.042		10,400	34,000	438	965	Average of two tests.	
	30	1.18	25	1	9.6	0.38	0.049		8,880	29,200	485	960	Do.	
	32	1.26	25	1	10.2	0.41	0.052		6,360	20,900	331	730	Do.	
	35	1.38	25	1	11.5	0.45					590	1,300	Fiber light colored, fine and oiled.	
	32	1.36	25	1	10.2	0.41					325	717	Fiber dark colored, coarse and unoiled; average of three tests.	
F ^b	27	1.06	25	1	8.6	0.35					446	985	One-strand rupture.	
F ^c	31	1.22	25	1	9.9	0.38		14			515	1,185	One-strand rupture in eye-splice.	
F ^b	35	1.38	29	1½	11.5	0.45					608	1,340	Do.	
F ^c	38	1.50	29	1½	12.1	0.48		17			772	1,700	One-strand rupture.	
F ^b	38	1.50	32	1½	12.1	0.48					942	2,075	One-strand rupture in splice.	
F ^c	40	1.58	32	1½	12.7	0.51		18			908	2,005	Do.	
F ^c	46	1.81	38	1½	14.6	0.57		18			1,170	2,580	Do.	
F ^b	46	1.81	44	1½	14.6	0.57					1,440	3,175	One-strand rupture in eye-splice.	
F ^b	51	2.01	38	1½	16.2	0.64					1,070	2,355	Fiber light colored, fine and oiled.	
	44	1.73	38	1½	14.0	0.54					524	1,155	Fiber dark colored, coarse and unoiled; average of three tests.	
F ^b	53	2.09	51	2	16.9	0.67					1,790	3,940	One-strand rupture in eye-splice.	
	68	2.68	63	2½	21.6	0.86	0.310		3,580	11,800	1,111	2,450	Average of two tests.	
	60	2.36	63	2½	19.1	0.76					2,180	4,805	Fiber light colored, fine and oiled.	
	60	2.36	63	2½	19.1	0.76					924	2,088	Fiber dark colored, coarse and unoiled; average of three tests.	

TABLE XV.—Tensile-strength tests of 1-meter lengths of three-strand, machine-laid, abacá rope from various Manila factories^a—Continued.

Grade.	Circumference.			Average diameter, based on circle having a circumference equal to girth.	Weight per unit length.		Elon- gation.	Breaking length.		Breaking load.	Remarks.		
	Actual average girth.		As labeled when received for testing.		Kilos per meter.	Pounds per ft.		Meter.	Feet.			Kilos.	Feet.
	mm.	in.	mm.										
F	102	4.02	89	3½	32.5	1.28				5,090	11,205	One-strand rupture.	
	112	4.42	102	4	35.7	1.41				3,320	7,335	Average of two tests.	
J ^e	127	5.0	102	4	40.5	1.6	0.728	0.489	4,570	15,000	6,730	Do.	
L ^b	127	5.0	102	4	40.5	1.6					6,260	Average of two tests; one-strand rupture in eye-splice in each specimen.	
J ^e	114	4.49	102	4	36.3	1.43					5,780	Average of two tests.	
L ^b	114	4.49	102	4	36.3	1.43					5,320	Do.	
L ^b	114	4.49	102	4	36.3	1.43					4,000	Two-strand rupture in eye-splice.	
L	104	4.10	102	4	33.1	1.31	0.691	0.464	5,520	18,100	3,810	Average of five tests; one-strand rupture in eye-splice in each specimen.	
Y ^d	102	4.10	102	4	32.5	1.28	0.630	0.423	6,520	21,400	4,100	Average of four tests; one-strand rupture in eye-splice in each specimen.	
	122	4.81	114	4½	33.8	1.53					7,390	One-strand rupture.	
	122	4.81	114	4½	33.8	1.53					5,170	Fiber light colored; fine and oiled.	
	114	4.49	114	4½	36.3	1.43					2,650	Fiber dark colored, coarse and unoiled; average of three tests.	
L	127	5.0	127	5	40.5	1.6	0.992	0.667	5,820	19,100	5,770	Average of three tests; one-strand rupture in eye-splice in each specimen.	
Y ^d	127	5.0	127	5	40.5	1.6					4,680	Do.	
	165	6.50	162	6	52.5	2.07	1.64	1.10	4,760	15,600	7,810	One-strand rupture in eye-splice.	
	165	6.50	162	6	52.5	2.07	1.46	0.982	5,720	18,700	8,350	Do.	
	183	7.21	152	6	58.3	2.29	1.67	1.12	8,080	26,500	13,500	Do.	

F c	188	7.21	152	6	58.3	2.29	1.67	1.12	6,750	22,200	11,250	24,820	One-strand rupture.
	175	6.90	152	6	55.7	2.19					10,850	23,920	
	170	6.70	152	6	54.2	2.13	1.59	1.07	6,790	22,300	10,800	23,830	
	190	7.48	152	6	60.5	2.38	1.60	1.08	6,760	22,000	10,800	23,800	
	190	7.48	152	6	60.5	2.38	1.63	1.03	7,580	24,900	11,600	25,600	

^a The actual measurements of average girth were made in millimeters, of weight per meter in kilograms, and breaking load in pounds, and the equivalents recorded are in round numbers accurate to a fraction of a per cent.

^c From Samar.

^d Damaged.

^e From northern Mindanao.

^f Test pieces 50 cm. long.

^g Four-strand rope.

^h From Laguna.

SUMMARY AND CONCLUSIONS

The data in the literature on the mechanical properties of coir are very deficient and often have been misinterpreted.

Coconut fiber in the Philippines is extracted in small quantity, entirely by the retting and beating process.

The results show retted filaments to average 228 millimeters, and machine-cleaned filaments, 245 millimeters, in length. Most filaments taper and have elliptical cross sections, the dimensions of which are given. The finest filaments have a circular cross section.

Tensile tests conducted on single filaments average 832 kilograms per square centimeter for the retted, and 1,208 kilograms per square centimeter for the machine-cleaned fiber. The difference in ultimate tensile strength is less marked when the fibers are fabricated into rope. The strength of coir filaments and coir cordage is very low, roughly, one-tenth that of single abacá filaments (Government inspected grades "F" and "G"); the strength of coir rope is about one-fifth that of abacá rope of the same size.

Immersion in tap water for twenty-four hours decreases the strength of coir rope from 14 to 26 per cent, whereas there is little change in the strength of abacá rope. Long immersion of the coir in fresh water produces little further change, but additional impairment is produced by the action of salt water and weather.

Coir cordage and coir filaments are characterized by great elongation, which in some cases attains 39 per cent. There is little difference between the ultimate elongation of the filaments and that of the rope, though in the latter it is slightly greater. Wetting increases the elongation of coir rope about 3 per cent.

Abacá filaments (grades "F" and "G") give an average elongation of only 3.6 per cent, but the ropes made from filaments of these grades give an elongation of from three to four times as much.

Coir has pronounced plastic properties and has no definite modulus of elasticity.

Due to the small elastic tensile resilience of coir its "shock-absorbing" power is relatively small, whereas abacá is a highly resilient fiber and is eminently suited to absorb shocks.

The coir industry in the Philippines should be developed in order to furnish a fiber for bristles, brushes, doormats, mattresses, cushions, ship fenders, etc.

ILLUSTRATIONS

- FIG. 1. Mechanical device for determining the elastic constants of coir and abacá filaments.
2. Comparative stress-deformation graphs of abacá and coir filaments, showing relative elasticity and resilience.
 3. Stress-deformation graphs of single, machine-cleaned, coir filaments; values taken from Table VII.
 4. Sectional profiles of 50-millimeter coir rope (full size).

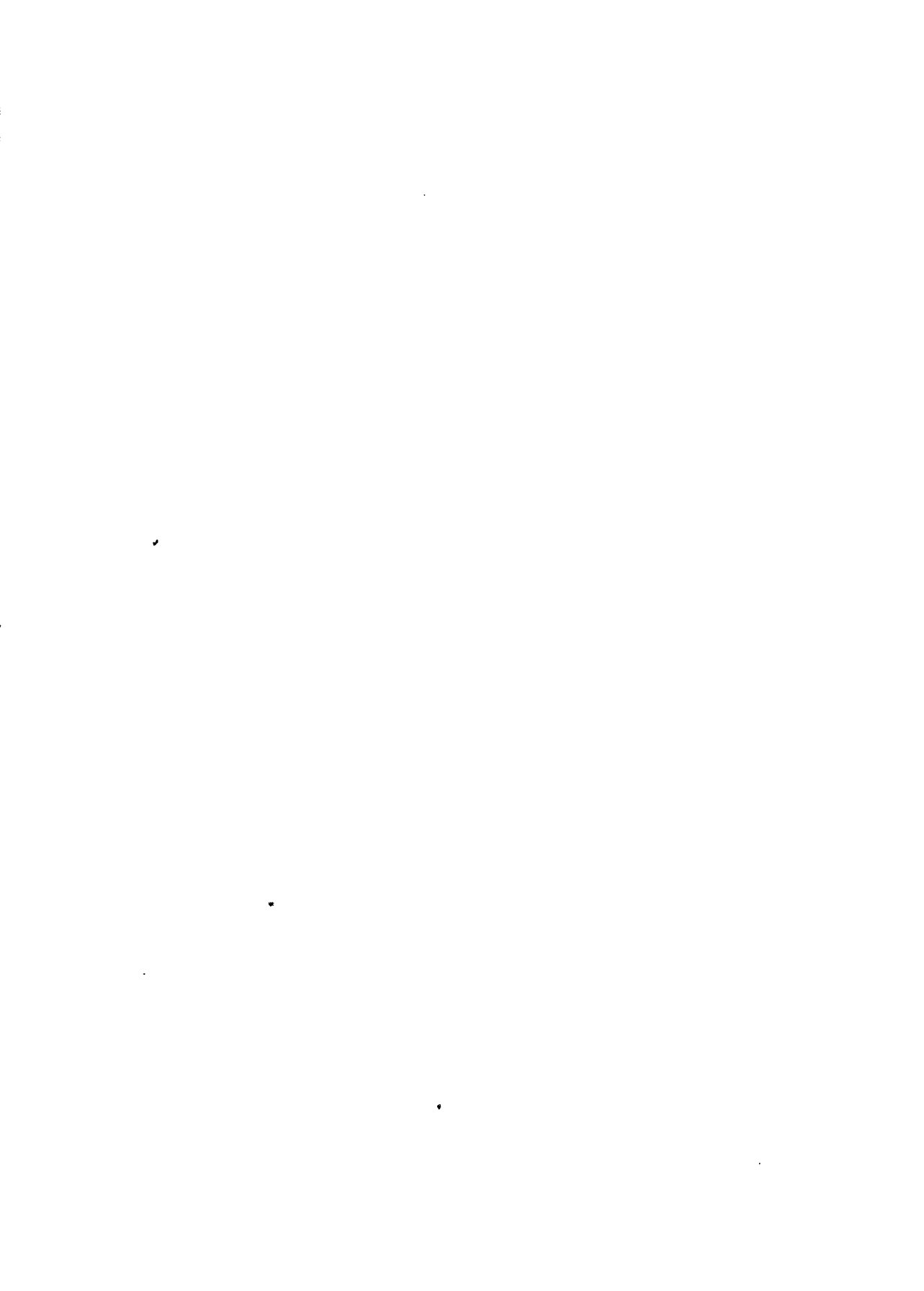

A RECALCULATION OF CERTAIN DATA ON STEAMING TESTS OF PHILIPPINE COALS

By F. R. YCASIANO¹

So far as known, the only trials of the steaming qualities of Philippine coal of which engineering data were kept for publication were made in the Insular Cold Storage Plant² and in the Bureau of Science.³ In the latter paper many tests were given, and I desire to present certain of the computations in a way which in my opinion will make them more available. Cox points out that the tests "are intended to be comparable only," but this recalculation makes their direct comparison with other similar results easier. Therefore, I will refer to the various pages of that paper by using the letter "p" followed by a number.

In computing the area of the heating surface of a water-tube boiler the outside diameter of the tube should be used,⁴ because the exterior surface is the part that comes in direct contact with the hot gases. Therefore on p. 304, where both external and internal measurements are given, the heating surface of the tubes, recalculated on the basis of the former, is 6,393 square decimeters; that of the drum, 839.3 square decimeters; and their total area, 7,232.3 square decimeters; instead of 5,715.2, 748.8, and 6,464.0 square decimeters, respectively, when the internal measurements were used. This total area affects the ratio of heating surface to grate surface (p. 304), which becomes 39.9:1 instead of 35.7:1.

In the calculation of the factor of evaporation the temperature of the feed water as it enters the water heater was used, whereas the temperature of the water as it enters the boiler should be used in computing this factor. The temperatures of the water as it enters the boiler are given, and using these data

¹ Mechanical and testing engineer, Bureau of Science.

² Donovan, J. J., McChesney, D., and Williams, W. P., *Far Eastern Review*, (1906), 2, 223.

³ Cox, Alvin J., *This Journal*, Sec. A (1908), 3, 301-356.

⁴ *Trans. Am. Soc. Mech. Eng.* 19, 572.

I have recalculated the factor in foot-note "f." p. 317, which then becomes:

$$\frac{658.9-79.2}{536.5} (\text{factor of evaporation}) \times 8.9615 \\ = 1.0786 \times 8.9615 = 9,666.$$

These calculations of the heating surface of the water-tube boiler and the factor of evaporation change the results of the tests shown in Table II, pages 313, 314, 315, and 316; Table III, pages 319, 320, and 321; and Table X, page 344. The recalculated values are shown under the respective headings in the following tables, which are self-explanatory:

From Table II, page 313. From Table II, page 314.

Test No.	Dry coal consumed per square decimeter of water-heating surface per hour.		Test No.	Combustible consumed per square decimeter of water-heating surface per hour.	
	Former value.	Recalculated value.		Former value.	Recalculated value.
	<i>Kilos.</i>	<i>Kilos.</i>		<i>Kilos.</i>	<i>Kilos.</i>
1	0.0317	0.0288	1	0.0277	0.0248
2	0.0321	0.0287	2	0.0282	0.0251
3	0.0268	0.0239	3	0.0243	0.0217
4	0.0296	0.0264	4	0.0257	0.0230
5	0.0299	0.0267	5	0.0260	0.0232
6	0.0354	0.0316	6	0.0309	0.0277
7	0.0327	0.0292	7	0.0293	0.0262
8	0.0374	0.0348	8	0.0363	0.0325
9	0.0393	0.0351	9	0.0382	0.0341
10	0.0381	0.0340	10	0.0346	0.0309
11	0.0326	0.0291	11	0.0304	0.0271
12	0.0325	0.0290	12	0.0308	0.0275
13	0.0326	0.0291	13	0.0315	0.0282
14	0.0299	0.0267	14	0.0290	0.0258
15	0.0359	0.0321	15	0.0328	0.0293
16	0.0416	0.0371	16	0.0364	0.0326
17	0.0309	0.0277	17	0.0290	0.0259
18	0.0291	0.0260	18	0.0272	0.0241

From Table II, page 315.

Test No.	Equivalent in kilos from and at 100° C.		Factor of evaporation.		Horse power developed.		Percentage of builders' horse power developed.	
	Former value.	Recalculated value.	Former value.	Recalculated value.	Former value.	Recalculated value.	Former value.	Recalculated value.
1	10.538	9.666	1.1759	1.0786	96.2	88.2	128	117
2	10.432	9.566	1.1754	1.0779	95.2	87.3	127	116
3	9.453	8.802	1.1750	1.0941	86.3	80.3	115	107
4	7.862	7.336	1.1734	1.0950	83.7	78.1	112	104
5	8.579	7.989	1.1724	1.0918	81.2	75.5	108	100.6
6	8.056	7.458	1.1769	1.0898	73.5	68.0	98	91
7	7.169	6.703	1.1749	1.0986	91.6	85.6	122	120
8	9.734	8.984	1.1742	1.0838	88.8	82.0	118	109
9	9.505	8.769	1.1757	1.0848	91.1	83.9	121	112
10	9.058	8.309	1.1773	1.0809	77.1	70.8	103	94
11	6.853	6.311	1.1749	1.0820	61.8	56.9	82	76
12	6.994	6.441	1.1749	1.0820	63.8	58.7	85	78
13	10.064	9.399	1.1746	1.0971	91.8	85.8	122	114
14	9.384	8.740	1.1752	1.0946	88.2	81.1	117	108
15	5.019	4.624	1.1642	1.0730	80.2	73.8	107	98
16	10.302	9.505	1.1757	1.0848	94.0	86.7	125	115
17	7.347	6.721	1.1780	1.0778	85.3	78.0	114	104
18	9.041	8.214	1.1785	1.0708	77.0	69.9	103	93

From Table II, page 316.

Test No.	Equivalent evaporation of water from and at 100° C. per hour.			
	Kilos.		Per square decimeter of water-heating surface.	
	Former value.	Recalculated value.	Former value.	Recalculated value.
1	1,505.4	1,380.8	0.232	0.190
2	1,490.3	1,366.5	0.230	0.188
3	1,350.4	1,257.4	0.209	0.173
4	1,310.3	1,222.6	0.203	0.169
5	1,271.0	1,183.5	0.197	0.163
6	1,150.7	1,065.4	0.178	0.147
7	1,433.8	1,340.6	0.222	0.185
8	1,390.6	1,283.4	0.215	0.177
9	1,425.7	1,315.4	0.220	0.181
10	1,207.7	1,107.8	0.187	0.153
11	987.5	891.0	0.150	0.123
12	999.1	920.1	0.154	0.127
13	1,437.7	1,342.7	0.222	0.171
14	1,373.3	1,279.2	0.213	0.176
15	1,254.7	1,156.0	0.194	0.159
16	1,471.7	1,357.0	0.227	0.187
17	1,335.8	1,222.0	0.207	0.168
18	1,205.5	1,095.2	0.187	0.151

From Table II, page 316.

Test No.	Equivalent evaporation of water from and at 100° C. per kilogram of—					
	Coal as fired.		Dry coal.		Combustible.	
	Former value.	Recalculated value.	Former value.	Recalculated value.	Former value.	Recalculated value.
1	7.150	6.556	7.356	6.745	8.394	7.691
2	6.970	6.388	7.169	6.572	8.182	7.545
3	7.661	7.132	7.798	7.259	8.601	8.068
4	6.694	6.247	6.839	6.381	7.867	7.338
5	6.429	5.981	6.568	6.116	7.555	7.086
6	4.930	4.564	5.022	4.650	5.741	5.316
7	6.682	6.246	6.771	6.332	7.568	7.074
8	5.435	5.015	5.747	5.303	5.914	5.459
9	5.307	4.889	5.611	5.178	5.775	5.327
10	4.650	4.267	4.904	4.499	5.390	4.945
11	4.317	3.975	4.586	4.224	4.924	4.584
12	4.476	4.122	4.755	4.379	5.015	4.618
13	6.400	5.978	6.815	6.363	7.041	6.575
14	6.682	6.224	7.113	6.624	7.313	6.811
15	4.426	4.077	5.400	4.974	5.910	5.445
16	4.453	4.108	5.471	5.010	6.241	5.758
17	5.985	5.474	6.651	6.085	7.106	6.500
18	5.775	5.245	6.411	5.813	6.855	6.226

From Table II, page 316.

Test No.	Equivalent evaporation of water from and at 100° C. per kilogram actually consumed of—					
	Coal as fired.		Dry coal.		Combustible.	
	Former value.	Recalculated value.	Former value.	Recalculated value.	Former value.	Recalculated value.
1	7.446	6.828	7.661	7.027	8.742	8.018
2	7.206	6.602	7.411	6.796	8.460	7.876
3	7.894	7.347	8.034	7.480	8.862	8.262
4	7.003	6.215	7.154	6.675	8.230	7.677
5	6.684	6.224	6.828	6.359	7.855	7.315
6	5.157	4.774	5.258	4.864	6.005	5.561
7	7.058	6.598	7.152	6.689	7.994	7.477
8	5.661	5.213	5.986	5.523	6.160	5.685
9	5.546	5.110	5.865	5.412	6.035	5.568
10	5.148	4.724	5.431	4.983	5.969	5.476
11	5.268	4.852	5.597	5.155	6.009	5.533
12	5.245	4.830	5.572	5.131	5.876	5.412
13	7.225	6.749	7.693	7.190	7.948	7.423
14	7.370	6.865	7.845	8.065	7.557	7.363
15	4.743	4.369	5.786	5.350	6.333	5.835
16	5.040	4.649	6.192	5.712	7.063	6.516
17	6.089	5.570	6.766	6.191	7.230	6.613
18	5.907	5.367	6.560	5.945	7.014	6.371

From Table II, page 316.

Test No.	Efficiency of boiler, including grate, in per cent based on the chemical analysis.	
	Former value.	Recalculated value.
1	57.99	53.17
2	56.53	51.81
3	58.86	53.82
4	51.40	47.96
5	49.36	45.96
6	39.53	36.61
7	50.30	47.03
8	43.75	40.37
9	42.72	39.42
10	41.04	37.64
11	37.62	33.86
12	37.76	34.77
13	52.15	48.68
14	54.24	50.51
15	51.10	47.07
16	52.40	47.98
17	52.89	48.39
18	51.04	46.27

From Table III, pages 319-321.

Test No.	Heat absorbed by the boiler.				Loss due to unconsumed hydrogen and hydrocarbons, to heating the moisture in the air, to radiation, and unaccounted for.			
	Former value.		Recalculated value.		Former value.		Recalculated value.	
	Calories.	Per cent.	Calories.	Per cent.	Calories.	Per cent.	Calories.	Per cent.
1	4,504	57.99	4,126	53.13	1,205	15.51	1,583	20.37
2	4,390	56.53	4,048	52.12	1,536	19.77	1,878	24.18
3	4,615	58.86	4,296	54.79	738	9.32	1,057	13.49
4	4,221	51.40	3,937	47.94				
5	4,053	49.36	3,775	45.97				
6	3,080	39.53	2,852	36.59	2,958	37.96	3,186	40.40
7	4,060	50.30	3,795	47.01	1,881	23.29	2,146	26.68
8	3,173	43.75	2,929	40.39	2,248	31.03	2,492	34.39
9	3,098	42.72	2,858	39.41	2,416	33.30	2,656	36.61
10	2,892	41.04	2,653	37.65	2,025	28.75	2,264	32.14
11	2,701	37.62	2,432	33.85	1,370	19.09	1,639	22.86
12	2,690	37.76	2,478	34.77	964	13.52	1,216	16.51
13	3,777	52.15	3,527	48.68	730	10.09	980	13.55
14	3,923	54.24	3,654	50.51	711	9.83	980	13.56
15	3,171	51.10	2,921	47.07	1,332	22.23	1,632	26.31
16	3,348	52.40	3,089	48.34	924	14.47	1,183	18.53
17	3,812	52.89	3,437	48.37	1,162	16.12	1,437	20.64
18	3,678	51.04	3,340	46.35				

From Table V, page 344.

Source.	Calorific value of the combustible in calories as determined in a Berthelot-Mahler bomb calorimeter.	Equivalent evaporation of water from and at 100° C. per kilo of combustible actually consumed.		Equivalent evaporation of water from and at 100° C. per kilo of combustible actually consumed, anticipated from the calorific value when Australian coal is taken as the base of comparison.	
		Former value.	Recalculated value.	Former value.	Recalculated value.
Australian (Westwaldrend); average of tests 1, 2, and 3, Table II	7,791	8,688	8,048	8,688	8,048
Batan Island (military reservation); average of tests 10, 11, 12, 13, and 14, Table II	7,166	6,773	6,241	8,000	7,402
Betts'; average of tests 15 and 16, Table II	6,297	6,698	6,175	7,020	6,505
Cebu (Comansi); average of tests 17 and 18, Table II	7,207	7,122	6,492	8,040	7,444
Polillo; test 19, Table II	7,358			8,210	7,601

ANALYSIS OF NORMAL FILIPINO URINE

By ISABELO CONCEPCION

(From the Department of Physiology, College of Medicine and Surgery,
University of the Philippines)

The main object of the present investigation is to study the several constituents of Filipino urine in order to get reliable standards of the different excretory products for comparison with American and European standards, and with those of other people living in the tropics. This is of extreme clinical importance, for it is evident that the standards of excretion of these constituents for Europeans and Americans, as given in physiological textbooks, cannot be accepted for Filipinos; therefore, any deduction of a clinical or practical nature based upon them must be misleading. The results given in this paper have been obtained from a series of analyses of the urine in different classes of the Filipino population of Manila.

In carrying on this investigation a uniform procedure was used throughout. The urine passed in each twenty-four hours was collected for from three to seven consecutive days in clean 2-liter bottles, containing 20 drops of saturated alcoholic thymol solution, and examined daily. The subjects of the experiments were all adults; namely, students in the physiology department of the university, laboratory helpers, Bilibid prisoners, and hospital servants, all living on a diet commensurate with their respective stations in life. All were allowed to choose their diet, except the Bilibid prisoners, who have a special ration. Therefore, these observations were made under ordinary conditions of everyday life. The diet was not controlled, for the reason that other investigators have shown that continued monotony of diet affects the appetite.

Quantity of urine.—As shown in Table I there is wide variation in the quantity of urine passed. In the average of each individual the lower and upper limits were 317 and 2,555 cubic centimeters, respectively, and the daily output showed even wider variation, the lowest amount passed in any one day being 265 and the largest 3,120 cubic centimeters. This variability for different individuals depends upon the kind of diet, the amount of water drunk, the condition of the individual, and the external temperature.

The average quantity found for the whole series of 236 daily specimens is 935 cubic centimeters. This figure is lower than the averages found for Americans or Europeans, and very much lower than the finding of McCay(1) on the Bengalis, as shown in Table II. This is probably explained by the high humidity and temperature of the Philippine atmospheric air, which cause excessive perspiration. These investigations were carried on during the months of April, May, and June. This deficiency of excretion is corroborated by the findings of Young,(2) on Europeans of long residence in the tropics, that during the hot humid weather the urines are comparatively small in volume and of high specific gravity.

Specific gravity.—The specific gravity was determined in all cases by means of an ordinary urinometer and the reading was corrected for the temperature by adding one unit of the last order to the observed specific gravity for every 3° above 15° C., the temperature at which the urinometer was calibrated.

In Europeans and Americans the average specific gravity of normal urine is 1.020 and varies with the health of the individual from 1.015 to 1.025. A very free use of beverages may often cause it to fall below 1.010. Under ordinary conditions, without regard to the amount of fluid ingested, so low a specific gravity might point to diabetes insipidus or to Bright's disease with deficiency of urea. A density above 1.030 frequently denotes sugar in the urine.(3)

A comparison of these standards with the figures given in Table I shows that the limits of variation in urine are very much wider for Filipinos than for Europeans. The average specific gravity of the Filipino cases varies between 1.003 and 1.031. The average specific gravity over the whole series of 208 daily specimens from laboratory helpers, hospital servants, and Bilibid prisoners is 1.017, and from the students, 1.021; the average for the whole series is 1.019. These results compare favorably with European standards and are slightly higher than those found by McCay on the Bengalis. This is to be expected on account of the small volume of urine passed in twenty-four hours.

Total nitrogen.—Total nitrogen was determined in duplicate by the original Kjeldahl method of estimation.(4) The total nitrogen excreted in twenty-four hours affords a measure of the total nitrogenous catabolism without regard to the specific forms in which the nitrogenous waste products are eliminated. In an individual of average size (70 kilograms) the total daily excretion of nitrogen, according to the results found for Euro-

peans and Americans, is usually between 14 and 18 grams. This would correspond to from 88 to 112 grams of proteins catabolized in twenty-four hours. It also means that, if nitrogen equilibrium were being maintained, an approximately equal quantity of assimilable protein food would be required. The minimum average of nitrogen excreted by Filipinos is 3.05 grams, the maximum 12.63 grams. The average for 142 determinations on prisoners, hospital servants, and laboratory helpers, and for 60 observations on students, was 6.27 and 7.75 grams, respectively. The average excretion over the whole series of 202 observations was 7.01 grams of nitrogen in twenty-four hours. This approximates the finding of Aron and Hocson,(5) but is very small, compared with European or American standards of nitrogen excretion. This means also that Filipinos metabolize 43.81 grams of proteins daily, which is only 37 per cent of Voit's standard and is slightly higher than the metabolism of the Bengalis, which averages 37.50 grams. The average for four consecutive days in the series of hospital servants, who gave the highest results, comes to only 79 grams of proteins metabolized daily. The minimum is as low as 19.13 grams, which is very much lower than the minimum, 23.25 grams, found by McCay.(1)

Urea.—This was determined by the Van Slyke and Cullen method.(6) It is generally recognized that the greatest proportion of nitrogen intake is excreted by the kidneys in the form of urea nitrogen, and is usually from 84 to 90 per cent of the total nitrogen. The accepted American or European standard for urea excretion is from 30 to 35 grams per diem. The average excretion of urea over the whole Filipino series of 196 determinations was 9.59 grams. The average for the student series is 10.80 grams, and for the laboratory helpers, prisoners, and hospital servants, 8.39 grams. The smallest amount of urea excreted, found in the case of one prisoner (P. 10378), was 4.24 grams for an average of seven consecutive days. The maximum quantity was that of a hospital servant (M. M.), 21.10 grams, for an average of four consecutive days. The average figure found in the student series is even smaller than that given in McCay's series, in spite of the fact that total nitrogen in my series is higher.

It should be noted that the excretion of urea nitrogen in the Filipino series is only 63.86 per cent of the total nitrogen excreted in the urine. Ordinarily, when the protein intake is high, about 90 per cent of the nitrogen of the urine is urea nitrogen; but on a reduced protein diet, as shown by Folin,(7)

the proportion of urea nitrogen falls to about 60 per cent of the total nitrogen. Mathews' (8) explanation of this variation of urea with the diet is that—

When more protein is eaten than is necessary to replace that decomposed in the vital process in the body, the body does not restore the excess since there is no provision for the storage of an excess of protein except in relatively small quantities. Instead of storing the excess the nitrogen is split off from the amino-acids converted into urea and excreted, while the carbonaceous part of the amino-acid molecule is converted into glucose or fat and stored in that form.

Uric acid.—Uric acid was determined in all cases by the Folin-Shaffer method. (9) The excretion of uric acid in a diet free from nucleo-proteins is fairly constant for each individual; it is then a product of endogenous metabolism. It can be increased by taking large amounts of animal food rich in nucleo-proteins, such as thymus gland, fish roe, etc. Healthy Europeans excrete from 0.30 to 0.75 gram of uric acid daily. In Americans it varies from 0.30 to 1.2 grams, with an average of 0.75 gram. The increased uric acid catabolism during fever, or in any condition when there is increased cellular destruction, has been observed by several investigators. (10) The average total output of the Filipino series of 214 determinations is 0.376 gram per day. The average of 61 observations among the students was 0.441 gram per day, and the series of 153 observations on the prisoners, laboratory helpers, and hospital servants, gave an average of 0.311 per day. This is very much lower than the European or American standards.

Creatinine.—Creatinine was determined in all cases by the Folin colorometric method, (11) using purified picric acid, as suggested by Folin and Doisy. (12) This is another product of endogenous metabolism. Folin has shown conclusively that the quantity of creatinine excreted on a low protein diet is practically the same as when the diet is rich in nitrogen. This constancy of the excretion of creatinine indicates that it is an index of the real metabolism of the vital machinery of the body proper in distinction from catabolism which increases the free energy. According to Folin the average excretion of creatinine in the normal individual varies from 1 to 2 grams a day in temperate climates. The average creatinine output in the whole Filipino series of 235 determinations was 1.478 grams per day. The average of 163 determinations on prisoners, laboratory helpers, and hospital servants is 1.274.

Leathes (13) found that during fever the amount of creatinine

in the urine was increased; this is due to the increased destruction of tissues during pyrexia. The experiments of Myers and Volovic(14) on rabbits have confirmed Leathes' observation, and have shown also that the output of creatinine was increased whether the pyrexia was caused by infection or by confining the animal in a hot atmosphere (39° to 40° C.). Young(15) made a number of creatinine determinations, both in hot weather and in the cooler seasons, on Europeans living in the tropics, and found that the daily averages range from 0.47 to 0.11 gram of creatinine nitrogen or from 1.26 to 1.91 grams of creatinine. My results corroborate the conclusion of Young that in the tropics there is no evidence of a greater creatinine output.

Shaffer(24) has found that the amount of creatinine excreted in adults is proportional to the body weight and is about 7 to 11 milligrams of creatinine nitrogen per kilogram. This is called the "creatinine coefficient." Although the chief factor determining the amount of creatinine elimination is the weight of the individual, the proportion between the body weight and the amount of creatinine in the urine is not very constant. Fat or corpulent persons yield less creatinine per unit of body weight than lean ones. The creatinine coefficient for Filipinos was 10.4 milligrams, which compares favorably with the standard creatinine coefficient.

Ammonia.—Ammonia was determined by Folin's original method.(16) The amount of ammonia normally present in the urine is about 0.7 gram a day. The amount and the relative proportion it makes of the total nitrogen of the urine is increased by the ingestion of mineral acids. It has been shown by several investigators that ammonia is an indicator of acid formation, that it is not due to physiologic disturbance of urea formation, that its sole function is the neutralization of acid bodies, and that it ceases to be formed in the presence of fixed alkali. Folin(17) found that,

With pronounced diminution in the protein metabolism there is usually, but not always, and therefore not necessarily, a decrease in the absolute quantity of ammonia eliminated. A pronounced reduction of the total nitrogen is, however, always accompanied by a relative increase in ammonia nitrogen provided that the food is not such as to yield alkaline ash.

The average ammonia output in the whole Filipino series of 213 observations was 0.641 gram per day. The average of 54 observations among the students was 0.685 gram, and the average for 159 determinations in the case of prisoners, laboratory helpers, and hospital servants was 0.598 gram.

Undetermined nitrogen.—Undetermined nitrogen was calculated by subtracting from the total nitrogen the ammonia, urea, uric acid, and creatinine nitrogen. Folin(7) has found that the absolute quantity of undetermined nitrogen is indirectly proportional to the protein intake and the total nitrogen. His average figure for undetermined nitrogen on a high protein diet is 2.7 to 5.3 per cent of the total nitrogen, while in a low protein diet it is 4.8 to 14.6 per cent of the total nitrogen. The average undetermined nitrogen in the Filipino series was 1.271 grams or 18.13 per cent of the total nitrogen. This high result on a low protein diet is in accordance with the findings of Folin as stated above.

Total phosphates.—The amount of total phosphates was determined by means of the uranium acetate method.(18) Phosphates are present in the urine as monosodium and disodium phosphates and free phosphoric acid. The total amount of phosphates as phosphoric anhydride (P_2O_5) in the urine of Americans is given as from 3.44 to 4.50 grams a day (an average of 3.87), and in Europeans, from 2 to 3.5 grams. The relation of phosphate to nitrogen excretion is from 1 to 5 or 6. The average in the Filipino series of 210 determinations was 1.285 grams phosphoric anhydride, and the ratio of this to nitrogen is 1 to 5.45. This figure is in comparatively close agreement with Aron's(5) finding for Filipinos, but is smaller than the European ratio, and slightly higher than the American ratio of 1 to 4.1. It is a well-recognized fact that the amount of phosphorus excretion is proportional to the quantity of protein diet. It is still more dependent upon the phosphate absorption. In man from 50 to 60 per cent of the intake is found in the urine, and 30 to 50 per cent in the faeces. For this reason a study of phosphorous excretion in the urine alone affords an unreliable elimination index.

Total sulphates.—The total oxidized sulphur was determined in the majority of cases by the Rosenheim and Drummond method(19) and in a few cases by Folin's gravimetric method.(20) The sulphates found in urine are derived mostly from the oxidation of sulphur of ingested protein molecules, and a relatively small amount is due to the ingested sulphates. The greater part of the sulphur is eliminated in the oxidized form; only a small proportion is excreted in the form of unoxidized or neutral sulphur compound. Under normal conditions the output of sulphuric acid is about 2.5 grams daily. About 75 to 95 per cent of this is in the form of oxidized sulphur, and about 90 per

cent of this oxidized sulphur is in the form of inorganic sulphate, and 10 per cent ethereal sulphate.

In Filipinos the average of 205 determinations was 1.475 grams of total sulphate, of which 1.169 grams is inorganic sulphate and 0.306 grams ethereal sulphate. As expected, the total oxidized sulphur was found to be less than in the case of Europeans or Americans. This figure for Filipinos is only about one-half of the standard figure given by Hawk.⁽²¹⁾ This should be expected, since the sulphuric acid excreted in the urine arises principally from the oxidation of protein material and, normally, is directly proportional to the amount of protein intake. Like urea, it is an index of total protein metabolism.

It was formerly believed that a ratio could be established between nitrogen and sulphuric acid. It has been suggested that for an average diet this ratio is as 5 to 1. However, when we come to consider that the percentage content of nitrogen and sulphur present in different proteins varies, the fixing of a ratio that will express the exact relation existing between the two elements, as they appear in the urine, is practically impossible. If we accept this ratio in a general way, and compare with it the ratio for Filipinos, we see that it is only a trifle more than three-fourths, since the ratio of nitrogen to sulphuric acid is as 3.87 to 1.

The ratio of the total oxidized sulphur to ethereal sulphates in an average American or European diet is from 10 to 1 to 12 to 1, while the ratio of Filipinos is only 5.45 to 1. This can be explained by the vegetable character of the diet, as it is a well-known fact that the usual ratio may be greatly reduced by a rich carbohydrate or an exclusive milk diet.⁽²²⁾

CHLORIDES

Chlorides were determined by the Volhard-Arnold method.⁽²³⁾ Next to urea, chlorides constitute the chief solid constituent of normal urine. The average daily output is about 10 to 15 grams, expressed as sodium chlorides; but the output is dependent in great part upon the nature of the food ingested, being high in a vegetable and low in a meat diet. It is also greatly increased temporarily after copious water drinking and with increased ingestion of salt in the food.

The average excretion over the whole series of 199 analyses is 5.86 grams daily. It is to be expected that the total quantity would be higher on account of the vegetable character of the diet of Filipinos, and their high chloride ingestion.

TABLE I.—Quantitative constituents of the urine of Filipinos.

BILIBID SERIES.

Individual.	Weight	Urine.	Specific gravity.	Total nitrogen N ₂ .	Urea.	Urea nitrogen.	Ammonia.	Ammonia nitrogen.	Creatinine.	Creatinine nitrogen.	Uric acid.	Uric acid nitrogen.	Undetermined nitrogen.
	Kilos.	cc.		Grams.	Grams.		Grams.		Grams.		Grams.		Grams.
P. 10878	53.4	855	1.005	3.0584	4.241	1.9793	0.2080	0.1734	0.61608	0.2282	0.07306	0.03463	0.3312
P. 10201	49.00	2,555	1.004	4.7406	6.7705	3.16065	0.41047	0.3432	0.8787	0.32607	0.3101	0.1478	0.76288
P. 10953	50.4	657	1.011	3.8616	5.1139	2.3769	0.4305	0.3538	0.8725	0.3236	0.1569	0.07469	0.72761
P. 35026	50.4	637	1.019	11.067	10.1308	4.7086	0.6884	0.6094	1.690	0.6271	0.3389	0.2507	4.8712
P. 10250	54.5	604	1.024	7.1227	12.5096	5.8352	0.6118	0.5098	1.905	0.7038	0.3972	0.1745	0.1006
P. 10224	43.6	497	1.020	4.6542	6.3694	2.9552	0.4790	0.3991	0.802	0.320	0.2683	0.1275	0.8524
P. 10231	40.4	1,257	1.004	3.4527	4.4385	2.0810	0.6007	0.5006	0.9145	0.3392	0.1844	0.1717	0.3602
P. 9839	55.4	1,230	1.008	7.7476	10.9606	5.1487	1.1315	0.9429	1.6155	0.5394	0.3892	0.1849	0.8717
P. 10029	54.00	2,532	1.004	8.2808	9.3966	4.6288	1.0525	0.8743	1.3509	0.4870	0.2481	0.1173	2.1734
P. 10279	60.4	2,562	1.003	6.5005	7.6345	3.5627	0.8669	0.6938	1.0486	0.3887	0.1305	0.06049	1.77481
P. 10402	50.9	1,264	1.009	4.7336	5.4137	2.5264	0.8211	0.6842	1.1575	0.4292	0.3959	0.1880	0.9056
P. 10187	53.3	1,773	1.004	7.1782	9.8806	4.5976	1.0184	0.8004	1.2944	0.4802	0.3888	0.1827	1.1178
P. 41957	45.4	374	1.023	5.203	4.796	2.240	0.4746	0.3964	1.1124	0.2159	0.1918	0.0925	1.8782
P. 41263	53.1	809	1.012	5.9831	7.3973	3.4587	0.5177	0.4314	1.0727	0.4126	0.3343	0.1291	1.5613
P. 41478	49.00	616	1.017	5.047	7.1061	3.3583	0.5551	0.4817	1.231	0.4918	0.3979	0.1723	0.5429
P. 41507	51.3	523	1.018	4.503	5.862	2.759	0.5550	0.4399	0.890	0.3945	0.3617	0.1710	0.7356
P. 41108	54.5	654	1.018	7.0614	9.0280	4.1121	0.5478	0.4792	1.520	0.562	0.2898	0.1377	1.7697
P. 41260	66.3	536	1.019	6.665	6.831	3.189	0.5009	0.4181	1.660	0.616	0.3293	0.1564	2.2850
P. 10082	43.6	704	1.016	5.943	7.1038	3.3157	0.5477	0.4695	1.327	0.492	0.4355	0.2070	1.4583
P. 11984	54.5	1,127	1.012	7.089	8.024	3.8121	0.5773	0.4811	1.654	0.608	0.3767	0.1803	2.0075
P. 38896	47.2	1,549	1.004	4.2227	5.5923	2.6037	0.4438	0.4048	1.304	0.433	0.1295	0.4337	0.6700

HOSPITAL SERVANTS SERIES.

D. V	48.00	317	1.008	4.765	8.9317	4.1683	0.2843	0.2231	1.1115	0.4124	0.1814	0.0868	0.1246
M. G	47.00	380	1.024	5.65	9.197	4.292	0.267	0.215	0.9229	0.3424	0.2017	0.0958	0.7848
F. M	48.00	460	1.031	5.587	13.506	6.3028	0.5902	0.4919	1.7127	0.6954	0.4037	0.1918	1.9651
M. M	55.00	824	1.028	12.639	21.103	9.863	0.8084	0.6487	2.139	0.7939	0.5823	0.3714	0.9620

LABORATORY-HELPERS SERIES.

G. L	54.35	569	1.014	5.6305	6.4019	2.9909	0.62412	0.5201	1.382	0.5127	0.39987	0.19007	1.41673
S. G	57.35	1,190	1.015	7.9824	10.6686	4.97634	0.64235	0.52902	1.65457	0.61367	0.5007	0.22286	1.58062

MEDICAL STUDENTS SERIES.

T. M	50.1	847	1.026	10.4015	13.4383	6.4719	0.83418	0.6951	1.8051	0.669	0.60712	0.2866	3.51925
J. P	48.00	477	1.028	6.615	9.6348	4.5009	0.4857	0.40465	1.475	0.547	0.43275	0.2056	0.50665
I. C	49.85	1,551	1.010	8.7897	12.8668	6.006	0.6621	0.5515	1.520	0.5664	0.8297	0.39866	1.27207
V. C. A	63.00	801		9.13866	12.36616	5.77976	0.75446	0.62368	2.290	0.811	0.21547	0.10235	1.68708
T. K		1,073		7.6034	12.9108	6.1504	0.6178	0.5322	2.532	0.929	0.3466	0.16462	0.17320
S. A	55.85	1,260	1.012	8.442	10.765	5.023	0.3752	0.3127	1.876	0.695	0.5395	0.2574	2.1535
R. A	53.6	443	1.024	7.153	10.8219	5.0494	0.5905	0.4922	1.559	0.567	0.1922	0.0887	0.9456
J. de J	46.3	1,097	1.010	8.1298	10.6927	4.990	0.6338	0.5282	1.772	0.667	0.4846	0.2302	1.7141
M. I.	55.4	925	1.013	6.426	7.085	3.3063	0.7995	0.6682	1.854	0.687	0.3996	0.1875	1.5781
A. O. C	48.00	530	1.024	8.337	12.987	6.178	0.62728	0.5227	1.703	0.627	0.4196	0.1988	0.8092
S. F.	47.2	905	1.019	9.013	11.892	5.5492	0.5686	0.4739	1.957	0.726	0.4532	0.2147	2.0488
D. L	50.5	751	1.012	6.245	7.959	3.8217	0.6964	0.5785	1.757	0.6518	0.4134	0.1966	0.9954
P. S	46.3	1,333	1.012	6.9735	11.621	5.424	0.4665	0.3887	2.1456	0.7960	0.4147	0.1971	0.1678

Average for prisoners, hospital servants, and laboratory helpers
 Average for medical students
 General average

51.6	987	1.017	6.27	8.39	4.43	0.598	0.498	1.274	0.473	0.311	0.108	1.236
51.2	924	1.021	7.75	10.80	5.04	0.665	0.570	1.685	0.625	0.441	0.147	1.306
51.4	985	1.019	7.01	9.59	4.43	0.641	0.534	1.478	0.549	0.376	0.125	1.271

TABLE I.—Quantitative constituents of the urine of Filipinos—Continued.
BILIBID SERIES.

Individual.	In per cent of total nitrogen.					● Total sul- phates as SO ₃ , "S," "Si," "So."				In per cent of total sulphates.		Total phosphates. P ₂ O ₅ .	Chlorides as NaCl.
	Urea.	Ammonia.	Creatinine.	Uric acid.	Undetermined N ₂ .	SO ₃ .	"S."	"Si."	"So."	"S ₂ ."	"S ₁ ."		
P. 10378	64.74	5.66	7.46	11.32	10.82	1.3238	0.7532	0.5676	56.8	48.1	.4671	3.68	
P. 10201	66.87	7.17	6.87	3.11	16.09	1.5648	0.4075	1.0144	26.2	64.7	.70177	3.81	
P. 10963	61.54	9.29	.84	1.93	18.84	0.9769	0.6729	0.4806	68.3	48.9	.4481	5.026	
P. 35026	42.54	5.50	56.75	22.65	4.39	1.6769	1.0921	0.5775	64.8	44.5	1.0308	4.86	
P. 10250	81.92	7.15	9.88	2.94	1.41	2.2084	1.3825	0.8259	62.4	37.6	1.0355	6.46	
P. 10224	63.49	8.57	6.87	2.73	18.31	0.6871	0.36288	0.3242	52.1	46.3	.5880	4.92	
P. 10231	60.27	14.49	9.82	4.97	10.43	0.8898	0.4759	0.4114	53.9	46.1	.5286	4.11	
P. 9839	66.45	12.17	7.73	2.38	11.25	1.0806	0.9178	0.1627	85.1	14.8	.8365	6.15	
P. 10029	55.89	10.55	5.88	1.41	26.24	1.3120	1.1355	0.4624	87.0	35.1	.8649	9.76	
P. 10279	54.30	10.65	5.97	.93	27.30	3.1038	1.9187	1.0185	61.9	32.9	.7141	7.10	
P. 10402	53.37	14.45	9.06	3.12	19.13	1.3525	1.2503	0.1022	92.5	74.0	.5979	5.55	
P. 10187	64.04	11.15	6.68	2.54	15.56	1.0161	0.68665	0.3261	67.6	32.3	.8456	7.5324	
P. 11957	44.59	7.6	8.0	1.84	37.39	1.168	0.6281	0.5398	53.8	46.1	.86	5.30	
P. 41263	57.71	7.19	6.88	2.15	26.05	1.5039	1.3265	0.0916	88.6	60.0	.9149	4.66	
P. 41478	66.54	9.5	9.74	3.41	10.88	1.485	1.201	0.1177	80.5	80.0	.7703	5.60	
P. 41507	61.27	9.77	8.76	3.73	13.40	0.9887	0.9266	0.0628	93.8	60.0	1.02	3.70	
P. 41108	58.23	6.78	7.96	1.95	25.06	1.2098	1.0146	0.1946	83.4	15.7	.97	5.90	
P. 10082	47.84	6.27	9.24	2.46	34.28	1.3846	1.1907	0.1941	86.2	13.5	1.17	7.80	
P. 10082	55.79	7.90	8.28	3.81	24.53	1.1554	0.7509	0.4049	64.6	34.4	1.3883	5.52	
P. 11984	53.77	6.78	8.6	2.54	28.31	1.2071	1.0477	0.2880	86.7	28.9	2.1988	7.08	
P. 38596	61.76	10.4	10.49	1.45	15.86	1.1070	0.7729	0.3341	69.3	29.7	1.425	5.98	

HOSPITAL SERVANTS SERIES.

D. V.....	87.47	4.68	3.86	1.3	2.61	1.0453	0.9680	0.0840	91.4	76.0	1.449	3.232
M. G.....	75.57	3.78	6.02	1.68	12.93	1.033	0.830	0.154	85.4	14.5	1.26	5.184
F. M.....	64.70	5.13	6.82	2.00	20.41	1.440	1.2373	0.2027	86.1	13.8	1.295	5.915
M. M.....	78.03	5.13	6.23	2.93	7.61	1.9685	1.8133	0.1612	91.8	81.0	2.09	8.678

LABORATORY HELPERS SERIES.

G. L.....	53.11	9.23	9.10	3.37	25.16	1.27715	0.92875	0.16175	72.6	12.5	0.735	7.11
S. G.....	62.73	6.66	7.73	2.93	19.92	1.5556	1.26897	0.29875	81.4	19.2	0.85877	11.8765

MEDICAL STUDENTS SERIES.

T. M.....	62.22	68.19	6.43	2.75	33.84	1.9647	1.71306	0.2516	87.2	12.7	1.671	8.72315
J. P.....	73.00	6.56	8.37	3.33	8.21	1.3914	1.1716	0.22125	84.1	15.8	1.1625	7.1372
I. C.....	68.32	6.27	6.44	4.47	14.40	2.4823	2.3387	0.1955	94.3	75.0	0.9324	13.0298
V. C. A.....	62.34	6.87	8.88	2.52	18.50	1.52485	1.4243	0.1175	98.4	78.0	1.27395	7.258
T. K.....	80.89	6.99	12.22	2.16	2.40	1.225	1.1925	0.0925	91.8	73.0	1.1568	5.3836
S. A.....	59.50	37.04	8.23	3.04	25.50	1.2862	1.0278	0.2584	79.8	20.1	1.2963	6.272
R. A.....	70.59	6.88	8.06	1.24	18.52	1.4760	1.2780	0.1960	86.4	13.5	1.367	1.547
J. de J.....	61.37	6.49	.82	2.83	21.08	1.2947	1.1474	0.1336	89.1	10.0	1.4467	4.289
M. I.....	51.64	10.36	10.70	2.91	24.58	1.0552	0.8866	0.1736	83.9	16.0	1.13	4.00
A. O. C.....	74.10	6.26	7.89	3.11	9.70	1.4440	1.296	1.1480	90.2	79.8	1.9474	5.251
S. F.....	61.56	6.25	8.05	2.38*	22.73	1.8312	1.4672	0.3640	80.3	19.1	2.4069	7.3164
D. L.....	61.19	9.27	10.43	3.10	15.13	1.535	1.144	0.391	73.5	25.3	2.239	5.729
P. S.....	78.33	6.59	11.41	2.82	2.40	1.643	1.3367	0.1615	87.0	10.8	2.425	11.7331

Average for prisoners, hos-

pital servants, and labor-

atory helpers.....

62.44

7.94

7.54

2.36

19.61

1.409

1.063

0.406

71.18

28.81

0.998

5.975

Average for medical stu-

dents.....

66.08

7.85

8.06

2.69

16.85

1.542

1.335

0.267

86.37

13.42

1.578

5.76

General average

63.86

7.61

7.83

2.55

18.13

1.475

1.169

0.306

79.25

20.74

1.285

5.862

TABLE II.—Showing the chemical composition of Filipino urine as compared with the known standards.

	Body weight.	Volume.	Specific gravity.	Total nitrogen expressed as N ₂ .	Urea.	Urea nitrogen.	Ammonia.	Ammonia nitrogen.	Creatinine.
	Kilos.	cc.		Grams.	Grams.	Grams.	Grams.	Grams.	Grams.
Europeans (McCay)	70	1,440	1.020	18	35	16.33	0.70	0.58	1.55
Americans (Folin)	68.4	1,430	1.022	16	29.8	13.9	0.84	0.70	1.55
Bengalis (McCay)	52	1,200	1.013	6	13	6.06			
Filipinos (Concepcion)	51.4	935	1.019	7.01	9.59	4.48	0.641	0.534	1.478
	Creatinine nitrogen.	Uric acid.	Uric acid nitrogen	Undeter- mined.	Total sul- phur oxid- ized ex- pressed as SO ₃ .	Inorganic sulphates expressed as SO ₃ .	Ethereal sulphates expressed as SO ₃ .	Total phos- phates ex- pressed as P ₂ O ₅ .	Total chlo- rides ex- pressed as NaCl.
		Grams.		Grams.				Grams.	Grams.
Europeans (McCay)	0.574	0.75	0.356	0.16	2.50	2.25	0.25	3.50	15
Americans (Folin)	0.58	0.37	0.12	0.60	3.31	2.92	0.22	8.87	10.1
Bengalis (McCay)		0.452	0.215		1.88	1.724	0.156	0.918	10
Filipinos (Concepcion)	0.549	0.376	0.125	1.271	1.175	1.169	0.306	1.285	5.86

ACKNOWLEDGEMENTS

I wish to express my thanks to Dr. Antonio Mañalak, of Bilibid Hospital, for his valuable coöperation in securing specimens of urine for me. My thanks are due also to the students for the loyal way in which they carried out the collection of the urine in every instance, and for the interest they took in the investigation.

REFERENCES

- (1) MCCAY. "Scientific Memoirs" (1908), No. 34.
- (2) YOUNG, W. J. *Ann. Trop. Med. and Parasitol.* (1915), 9, 91.
- (3) HOLLAND. Medical chemistry. W. B. Saunders & Co., Philadelphia (1915), 594.
- (4) HAWK. Practical physiological chemistry. P. Blakiston's Son & Co., Philadelphia, 5th ed. (1916), 483.
- (5) ARON and HOCSON. *Phil. Journ. Sci., Sec. B* (1916), 6, 365.
- (6) VAN SLYKE and CULLEN. *Journ. Biol. Chem.* (1914), 19, 141.
- (7) FOLIN. *Am. Journ. Physiol.* (1905), 13, 118.
- (8) MATTHEWS. Physiological Chemistry. William Wood & Co. (1915), 689.
- (9) FOLIN-SHAFFER. *Zeit. Physiol. Chem.* (1901), 32, 552.
- (10) Cited by von Fürth. Chemistry of Metabolism, Translated by Smith. J. B. Lippincott Co., Philadelphia (1916), 619.
- (11) FOLIN. Described by Hawk, op. cit., 506.
- (12) FOLIN and DOISY. *Journ. Biol. Chem.* (1917), 28, 349.
- (13) LEATHES. *Journ. Physiol.* (1907), 35, 205.
- (14) MYERS and VOLOVIC. *Journ. Biol. Chem.* (1913), 14, 489.
- (15) YOUNG. Loc. cit.
- (16) FOLIN. Described by Hawk, op. cit., 499.
- (17) IDEM. *Am. Journ. Physiol.* (1905), 13, 117.
- (18) HAWK. Op. cit., 552.
- (19) ROSENHEIM and DRUMMOND. *Biochem. Journ.* (1914), 8, 143.
- (20) HAWK. Op. cit., 546.
- (21) IDEM. Ibid., 404.
- (22) HAMMERSTEN and HEDIN. Text-book of Physiological Chemistry, John Wiley and Sons, New York (1915), 724.
- (23) HAWK. Op. cit., 556.
- (24) SHAFER. *Am Journ. Physiol.* (1908), 23, 1.



REVIEW

Plane Trigonometry | with Tables | by | Eugene Henry Barker | head of the department of mathematics, Polytechnic | High School, Los Angeles, California | with 86 illustrations | Philadelphia | P. Blakiston's Son & Co. | 1012 Walnut Street | Cloth, pp. i-vii + 1-172, including index. Price \$1 net.

361

INDEX

- A**
- Abacá, 221.
 Acerbia maydis, 253.
 Aeginetia indica, 237.
 Aithaloderma longisetum, 201.
 Ammoniacal solution of copper carbonate, 258.
 Analyses of Batan and Fushon coal, 112.
 producer and exhaust gases, 120.
 Analysis of copra cake, 123.
 normal Filipino urine, 347.
 Ananas comosus, 172.
 sativus, 172.
 Andropogon schoenanthus, 238.
 sorghum, 173.
 Angular leaf spot, 208.
 Annona muricata, 175.
 Anona squamosa, 207.
 Anthostomella arecae, 177.
 cocoina, 197.
 Apiospora camptospora, 240.
 Apium graveolens, 175.
 Apparatus used in field assay of water, 19.
 Arachis hypogaea, 176.
 Areca catechu, 177.
 Arenga saccharifera, 333.
 Artocarpus communis, 178.
 incisa, 178.
 integra, 178.
 integrifolia, 178.
 Aschersonia sclerotoides, 192.
 Aspergillus delaeroixii, 245.
 periconioides, 184.
 Asterinella stuhlmanni, 172.
 Asteroma phaseoli, 231.
 Austin, F. E., *see* Reviews (book).
- B**
- Bacillus carotovorus, 238.
 coli, 2, 15, 195, 263.
 phytophthorus, 243.
 prodigosus, 214.
 solanacearum, 181, 217, 222, 241, 242.
 Bacterial blight, 222, 229.
 bud rot, 192.
 heart rot, 221.
 leaf stripe, 225.
 soft rot, 233.
 stem rot, 220, 240.
 wilt, 181, 217, 222, 241, 242.
 Bacterium malvaceum, 208.
 Baker, Eugene Henry, *see* Reviews (book).
 Bakerophoma sacchari, 234.
 Banana, 220.
 Bark rot, 184.
 Beans, 229.
- BERHMAN, A. S., Two field methods for the determination of the total hardness of water, 21; *see also* HEISE, GEORGE W. and BERHMAN, A. S., 1.
 Beta vulgaris, 179.
 Betel palm, 177.
 pepper, 231.
 Bitter pomelo, 185.
 Blackleg, or potato stem rot, 243.
 Black rot, 179.
 of fruits, 209.
 pods, 244.
 Blast of kernels, 249.
 Blight, 201, 205, 214, 229, 233, 243, 247.
 Botryodiplodia anceps, 220.
 Botryosphaeria minuscula, 246.
 Brassica oleracea, 179.
 pekinensis, 180, 181.
 Breadfruit, 178.
 Broad bean, 69.
 Broomella zaeae, 253.
 Bunga, 177.
 Burgundy mixture, 257.
- C**
- Cabbage, 179.
 Cacao, 244.
 Caesalpinia sappan, 207.
 Cajanus cajan, 69.
 Calabaza, 202.
 Calamismis, 232.
 Calonectria perpusilla, 227.
 Calorific values of producer gas, 121.
 Camoting cahoy, 219.
 Canavalia ensiformis, 181.
 gladiata, 68, 181.
 Canker, 185, 210, 245.
 Canton mandarin, 185.
 Capnodium footii, 197.
 Capsicum annum, 181.
 frutescens, 181.
 spp. 207.
 Carica papaya, 182, 207.
 Carrot, 203.
 Cassava, 219.
 Ceara rubber, 219.
 Celery, 175.
 Cercospora, 179, 180, 202, 203, 204, 218, 227, 230, 234, 241, 248, 255.
 apii, 175.
 armoraciae, 180.
 artocarpi, 178.
 brassicicola, 180.
 canavalliae, 181.
 henningsii, 219.

- Cercospora lussoniensis*, 230.
mangiferae, 218.
manihotis, 219.
nicotianae, 224, 225.
pachyderma, 203.
sesami, 240.
stizolobii, 220.
ubi, 203.
Chaetosphaeria eximia, 197.
 Chard, 179.
 Chemical analysis of cements, 37.
 Chick pea, 69.
 Chlorosis nonparasitic, 186.
Chromosporium crustaceum sp. n., 214.
Cicer arietinum, 69.
Citrus, 185.
 decumana, 185, 188, 191, 207.
 hystrix, 185.
 japonica, 185.
 maxima, 185, 188, 191, 207.
 medica, 185.
 mitis, 185.
 nobilis, 185, 186, 188, 191.
 spp., 184, 185.
Cladosporium herbarum, 231.
Clasterosporium maydicum, 253.
 punctiforme, 227.
 Coal, 100.
 COCANNOUER, JOSEPH, A., Tests of some imported garden legumes, 67.
 Coconut, 192.
Cocos nucifera, 192.
Coffea arabica, 199, 200, 201, 207, 255.
 excelsa, 199.
 liberica, 255.
 robusta, 200, 255.
 spp., 198.
Colletotrichum arecae, 177.
 gloeosporioides, 192.
 lussoniense, 219.
 papayae, 184.
Colicasia antiquorum, 201.
 esculentum, 201.
 CONCEPCION, ISABELLO, Analysis of normal Filipino urine, 347.
Coniosporium dendriticum, 198.
 extremorum, 240.
 oryzinum, 228.
 sorghii, 175.
 vinosum, 240.
Coniothyrium coffeae, 201.
 Control of plant diseases, 253.
Coprinus fimbriatus, 197.
 friesii var. *obscurus*, 198.
 Corn, 249.
 Corrosive sublimate, 262.
Corticium salmonicolor, 190.
 Cotton, 208.
 Cowpea or paayap, 68, 247.
 COX, A. J., and HEISE, G. W., review of Kremann's The application of physico-chemical theory to technical processes and manufacturing methods, 97.
 Crop rotation, 253.
 Cucumbers, 202.
Cucumis sativus, 202.
Cucurbita maxima, 202.
 Cultural methods, 254.
 Curing and fermenting troubles, 228.
 Curly top, 247.
Cycloderma depressum, 178.
Cyphella holstii, 246.
Cytospora aberrans, 188.
 palmicola, 198.
- D**
- Damping off, 182, 187, 198, 218.
 of seedlings, 224.
Daucus carota, 203.
 Description of Bureau of Science producer-gas power plant, 101.
Diaporthe citrincola, 188.
Dichotomella areolata, 179.
Dictyophora phalloidea, 236.
Didymella caricae, 184.
 lussoniensis, 204.
Didymium squamulosum, 181.
Didymosphaeria anisomera, 175.
 Die-back, 246.
Dioscorea esculenta, 203, 204.
Diplodia ananassae, 173.
 arecina, 177.
 artocarpi, 178.
 artocarpina, 179.
 aurantii, 188.
 caricae, 184.
 cococarpa, 198.
 var. *malaccensis*, 198.
 crebra, 220.
 epicocos, 197.
 var. *minuscula*, 198.
 lablab, 204.
 manihoti, 219.
 mori, 220.
 phaseolina, 231.
Diplodin degenerans, 242.
 Disease-resistant varieties, 255.
Djersek boli, 185.
Dolichos lablab, 68, 204.
 uniflorus, 204, 229.
 Downy mildew, 202, 207, 249.
 Dry rot, 250.
 sooty rot, 246.
- E**
- Early blight, 175.
 Effect of electrolytes on cement as reported by a number of investigators, 30.
 Egg plant, 241.
Elfvigia tornata, 178, 198.
Ellisiodothis rehmana, 203.
Elsinoe canavaliae, 181.
Endoxyla mangiferae, 219.
Entyloma oryzae, 228.
Epiphytes, 188.
Ervum lens, 70.
Erysiphaceae, 171, 181, 183, 203, 218, 231, 241, 248.
Eugenia uniflora, 207.
Eurotium candidum, 214.

- Eutypella citricola*, 188.
 cocos, 198.
 heteracantha, 188.
 heveae, 214.
 rehmana, 178.
- Exosporium durum*, 196.
 hypoxyloides, 177.
 pulchellum, 177.
- F**
- False smut or lump smut, 226.
 Fertilizer experiments with sugar cane, 135.
Ficus carica, 204.
 Fig, 204.
Fomes lignosus, 212.
 Foot rot, 198.
 Formaldehyde, 261.
 Formalin, 261.
 disinfection, 256.
 spray, 261.
 Fruit blast, 220.
 rot, 178, 181, 182, 188, 189, 241.
Fumago vagans, 175.
 Fungi, 197, 214.
 Fungicides, 256.
Fusarium, 182, 214, 224, 247, 249, 255.
 heveae, 184.
 theobromae, 244, 245.
- G**
- Gabi, 201.
Ganoderma incrassatum var. *substipitata*, 198.
 Garden pea, 69.
 Gas-generator tests, 115.
Gloeoglossum glutinosum, 198.
Gloeosporium canavaliae, 181.
 catechu, 177.
 intermedium, 192.
 macrophomoides, 203, 241.
 melongenae, 241.
 palmarum, 177.
 Glume spot, 227.
Glycine hispida, 70, 204, 206, 207.
 max, 70, 204, 206, 207.
Gossypium brasiliense, 209.
 herbaceum, 209.
 spp., 20.
 Grain mold, 173.
Guignardia arecae, 177.
 manihoti, 219.
 var. *diminuta*, 219.
- Gummosis*, 189.
- H**
- Haplographium chlorocephalum*, 227.
Heplosporella melanconioides, 240.
 HEISE, G. W., see WRIGHT, J. R., and
 HEISE, G. W., 49; see also COX, A. J., and
 HEISE, G. W., 97.
 HEISE, G. W., and BEHRMAN, A. S., Water
 analysis in the field, 1.
- Helminthosporium*, 227.
 caryopsidum, 173.
 curvulum, 252.
 heveae, 211.
 inconspicuum, 251, 252,
 253.
 sesameum, 241.
- Hemileia*, 200.
 vastatrix, 199.
- Heterodera radicolica*, 225, 237.
Hevea, 210.
 brasiliensis, 209.
Hibiscus cannabinus, 288.
 sabdarriffa, 207, 214.
Hormodendron cladosporioides, 197.
 Horse beans, 181.
Hypoxylon atropurpureum (on coccids), 188.
- I**
- Icmo, 231.
 Imperfect fungus, 191.
Ipomoea batatas, 215.
- J**
- Jack fruit, 178.
- K**
- Kaffirs, 173.
 Kernel smut, 173.
 Kidney bean, 67.
 KING, ALBERT E. W., The mechanical prop-
 erties of Philippine coir and coir cordage
 compared with abacá (Manila hemp), 285.
 Kremann, R., see Reviews (book).
Kuehneola desmium, 209. *
 fici, 204.
 var. *moricola*, 219.
- L**
- Lablab bean, 68, 204.
 Large pomelo, 185.
Lasiodiplodia, 215.
 theobromae, 182, 188, 208, 215,
 245, 246, 247.
 Leaf rot, 183.
 spot, 172, 173, 175, 176, 178, 179, 180,
 196, 199, 202, 203, 204, 211, 218, 219,
 220, 222, 223, 224, 227, 230, 233, 234,
 235, 240, 241, 242, 248, 249, 251.
Lembosia bromeliacearum, 172.
 Lemons, 184.
 Lentil or lens, 70.
Leptosphaeria (*Leptosphaerella*) *oryzina*, 227.
 orthogramma, 253.
Leptothyrium circumscissum, 219.
 Lettuce, 216.
 Lichens, 189, 247.
 Lima bean, 67.
 Limes, 184.
 Lime-sulphur spray, 260.
 Linga, 240.
 Liquid fuel, 101.
Lonchocarpus sp., 207.
Loranthus philippensis, 188.

Lactuca sativa, 216.
Lycopersicum esculentum, 217.

M

Maerophoma, 220.
 musae, 220, 222.
Maize, 249.
Mangifera indica, 218.
Mango, 218.
Mani, 176.
Manihot dichotoma, 219.
 utilissima, 219.
Marasmius, 236.
Marchalia constellata, 178.
Massarina raimundoi, 188.
Mechanical extraction of coir, 275.
 properties of Philippine coir and
 coir cordage compared with
 abacá (Manila hemp), 285.
Megalonectria pseudotrichia, 210.
Melanconium lineolatum forma,
 sacchari, 235, 236.
Meliola, 191.
 arundinis, 240.
 mangiferae, 219.
Methods of burning pottery in the vicinity of
 Manila and their influence on the quality
 of the product, 59.
Micropeltis, 192.
 mucosa, 199.
Milos, 173.
MIRASOL Y JISON, JOSÉ, Fertilizer exper-
 iments with sugar cane, 135.
Miscellaneous fuels, 101.
Moraceae, 219.
Morus alba, 219.
Mottled leaf, nonparasitic, 189.
Mucuna deeringiana, 220.
 nivea, 70.
Mulberry, 219.
Mungo, 69.
Musa sapientum, 220.
 textilis, 221.
Mycogone cervina var. *theobromae*, 245.
Mycosphaerella, 221.
 caricae, 183.
 dioscoreicola, 204.
 musae, 220, 222.
Myrothecium oryzae, 227.

N

Nangca, 178.
Nectria bainii var. *hypoleuca*, 245.
 discophora, 246.
 episphaeria, 188.
Nematodes, 225, 237.
Nicotiana tabacum, 207, 222.
Normal Filipino urine, analysis of, 347.

O

Oospora oryzaetorum, 228.
 perpusilla, 231.
Ophiobolus oryzinus, 228.
Ophionectria theobromae, 246.

Orange galls, 204, 232.
Oranges, 184.
Oryza sativa, 225.

P

Pachyrrhizus angulatus, 229.
 erosus, 229.
Palawania cocos, 197.
Papaya, 182.
Para rubber, 209.
Passarini, 173.
Passiflora quadrangularis, 207.
Pea, 231.
Peanut, 176.
Pechay, 180.
Penicillium, 182, 189.
 maculans sp. n., 214.
Peroneutypella arecae, 178.
 cocoes, 198.
Pernonospora, 207.
Pestalozzia funera, 219.
 palmarum, 177, 196.
 pauciseta, 219.
Phakospora pachyrhizi, 229.
Phaseolus aureus, 69.
 calcaratus, 206, 207, 229, 230, 231.
 lunatus, 67, 71, 75, 207, 230, 231.
 mungo, 69, 231.
 vulgaris, 67, 71, 80, 207, 229, 231.
 spp., 229.
Phellostroma hypoxylodes, 178.
Philippine economic-plant diseases, 165, 217.
Phoma bakeriana, 248.
 herbarum, 219.
 oleraceae, 203.
 sabdariffae, 214.
 sesamina, 241.
 solanophila, 242.
Phomopsis arecae, 177.
 capsici, 181.
 dioscorea, 203.
 palmicola, 177.
Phyllachora, 204, 219.
 dioscoreae, 203.
 phaseolina, 230.
 rehmiana, 203.
 sacchari, 235.
 spontanei, 235.
 sorghii, 173.
Phyllactinia suffulta, 219.
Phyllostictis citrella, 185.
Phyllosticta circumsepta, 189.
 cocophylla, 197.
 glumarum, 227.
 graffiana, 204.
 insularum, 175.
 manihoticola, 219.
 miurai, 227.
Physalospora affinis, 245.
 guignardioides, 181.
 linearis, 253.
Physical properties of coir filaments in ten-
 sion, 293.
Physiological trouble, 211.

- Phytophthora*, 182, 202, 249.
colocasiae, 201.
faberi, 182, 209, 210, 244, 245, 246.
infestans, 243.
nicotianae, 224, 255.
- Pigeon pea, 69.
 Pineapple, 172.
 Pink disease, 190.
 Piper beetle, 231.
Pisum arvense, 70.
sativum, 69, 71, 231.
- Plan of the producer-gas plant, 102.
 Plant sanitation, 253.
Plasmopara cubensis, 202.
Plicaria bananincola, 220.
 Pod spot, 248.
 Pomelos, 184.
 Portland cement, the solubility of, and its relation to theories of hydration, 147.
 Potato, 242.
stem rot, 243.
- Powdery mildew, 181, 183, 203, 218, 219, 231, 241, 248.
- Practical operation of a producer-gas power plant, 99.
- Premna cumingiana*, 171.
- Preparation and standardization of potassium palmitate tablets, 23.
- Pseudomonas campestris*, 179.
citri, 185.
phaseoli, 80, 94, 229.
- Psophocarpus tetragonolobus*, 69, 204, 232.
- Puccinia kuehni*, 237.
purpurea, 174.
- Pythium debaryanum*, 182, 218, 224, 225.
- ### R
- Radish, 233.
- Radium content of water from the China Sea, 49.
- Raphanus sativus*, 233.
- Reana luxurians*, 250.
- Recalculation of certain data on steaming tests of Philippine coals, 341.
- Red pepper, 181.
- REINKING, OTTO A., Philippine economic-plant diseases, 165, 217.
- Resin-salsoda sticker, 259.
- Results of commercial tests of Uling coal (Cebu, P. I.) in the producer-gas power plant of the Bureau of Science, 124.
- REVIEWS (book):
 Austin, F. E., Preliminary mathematics, 97.
 Baker, Eugene Henry, Plane Trigonometry with Tables, 361.
 Kremann, R., The application of physico-chemical theory to technical processes and manufacturing methods, 97.
- REYES, F. D., *see* WITT, J. C., and REYES, F. D., 147.
- Rhizoctonia*, 182, 187, 198, 203, 205, 206, 218, 224, 227, 228, 229, 233, 247, 255.
- Rhizopus*, 178, 182, 203, 215.
artocarpi, 178.
- Rice, 225.
- Rind disease, 235.
- Root disease, 242, 236.
galls, 225, 237.
 parasite, 237.
rot, 177.
- Roselle, 214.
- Rosellinia cocolis*, 198.
- Rust, 174, 199, 203, 204, 208, 209, 219, 229, 231, 237, 249.
- ### S
- Saccharum officinarum*, 207, 233, 235.
spontanum, 235, 239.
- Saprophytic fungi, 213.
- Sarcinella raimundoi*, 242.
- Satsuma orange, 185.
- Scaly bark, 191.
- Sclerospora javanica*, 249.
maydis, 249, 250.
- Sclerotium*, 177, 187, 198, 224, 228, 229, 255.
- Self-boiled lime-sulphur spray, 260.
- Septogloeum arachidis*, 176.
- Septoria lablabina*, 204.
lablabis, 204.
miyakei, 227.
- Sereh, 238.
disease, 237.
- Sesame, 240.
- Sesamum indicum*, 240.
- Sincamas, 229.
- Smut, 239, 252.
- Soda Bordeaux mixture, 255.
- Soil sterilization, 255.
- Soja, 204.
- Solanum melongena*, 241.
tuberosum, 242.
- Solubility, the, of Portland cement and its relation to theories of hydration, 147.
- Some generalizations on the influence of substances on cement and concrete, 29.
- Sooty mold, 172, 175, 191, 197, 201, 231, 240.
- Sordaria oryzei*, 228.
- Sorghum vulgare*, 173.
- Sources of power in the Philippines, 100.
- Soursop, 175.
- Soy bean, 70, 204.
- Spegazzinia ornata*, 228.
- Spiny mold, 191.
- Sporodesmium bakeri*, 220.
- Spotting of prepared plantation rubber, 213.
- Spraying apparatus, 262.
- Squash, 202.
- Standard Bordeaux mixture, 257.
 legumes of the world, 67.
- Steirochaete ananassae*, 173.
lussoniensis, 219.
- Stem disease, 201.
rot, 203, 227, 228.
 bacterial, 220, 240.
- Sterile fungus, 250.
- Sterility of nuts, 197.
- Stizolobium deeringiana*, 220.
- Storage rots, 203, 215.
- Straight, or sterile, head, 228.
- Sugar cane, 233.

THE PHILIPPINE BUREAU OF SCIENCE

RECENT PUBLICATIONS

AN INTERPRETATION OF RUMPHIUS'S HERBARIUM AMBOINENSE

By E. D. MERRILL

Based on the collections made in Amboina by the late Charles Budd
Robinson

Order No. 450. Bureau of Science Publication No. 9. Paper, 595 pages and 2 maps.
Price \$3, United States currency, postpaid.

The Herbarium Amboinense is a classical work on the Malayan flora and one that is absolutely essential to the systematist to-day. The great importance of the work is due to the fact that later authors have made the Rumphian descriptions and figures the actual "types" of many binomials. As an original source the Herbarium Amboinense stands preëminent among all the early publications on Malayan botany.

Professor Merrill's interpretation of the Herbarium Amboinense discusses the status of each species described by Rumphius and assigns it to a position in the modern system of classification. This publication will be of great service to any one working on Indo-Malayan systematic botany.

A GRAMMAR OF LEPANTO IGOROT AS IT IS SPOKEN AT BAUCO

By MORICE VANOVERBERG

Order No. 438. Vol. V, Part VI, Division of Ethnology Publications. Paper, 102 pages.
Price \$0.75, United States currency, postpaid.

This part completes Volume V of the Division of Ethnology publications and includes the index and the title-page for the volume. A title-page for Volume II is printed with this number.

PLEASE GIVE ORDER NUMBER

Orders for these publications may be sent to the BUSINESS MANAGER, Philippine Journal of Science, Bureau of Science, Manila, P. I., or to any of the following agents:

AGENTS

THE MACMILLAN COMPANY, 64-66 Fifth Avenue, New York, U. S. A.
WM. WESLEY & SON, 28 Essex Street, Strand, London, W. C., England.
MARTINUS NIJHOFF, Lange Voorhout 9, The Hague, Holland.
KELLY & WALSH, Limited, 32 Raffles Place, Singapore, Straits Settlements.
A. M. & J. FERGUSON, 19 Baillie Street, Colombo, Ceylon.
THACKER, SPINK & Co., P. O. Box 54, Calcutta, India.

CONTENTS

	Page.
VALENCIA, F. V. Mechanical extraction of coir.....	275
KING, ALBERT E. W. The mechanical properties of Philippine coir and coir cordage compared with abacá (Manila hemp)....	285
YCASIANO, F. R. A recalculation of certain data on steaming tests of Philippine coals.....	341
CONCEPCION, ISABELO. Analysis of normal Filipino urine....	347
REVIEW	361
INDEX	363

The Philippine Journal of Science is issued in four sections. Each section consists of six numbers a year, is separately paged and indexed, and is a complete publication in itself. Authors receive 100 copies of their papers free.

SUBSCRIPTION RATES TO CURRENT VOLUME	U. S. currency.
Section A (Chemical and Geological Sciences and the Indus- tries)	\$2.00
Section B (Tropical Medicine).....	3.00
Section C (Botany), Elmer D. Merrill, B. S., M. S., Editor.....	2.00
Section D (General Biology, Ethnology, and Anthropology). Section D began with Volume V.....	2.00
Entire Journal (4 sections).....	7.00

PRICES OF BACK NUMBERS AND VOLUMES	
Entire Journal, Volume II, III, or IV (3 sections each); or V (4 sections)	5.00
Entire Journal, beginning with Volume VI (per volume).....	7.00
Single numbers of Volume I.....	.75
Single numbers (except of Volume I).....	.50
Volume I, 1906 (not divided into sections), and supplement, sold only with a complete file of section A, B, or C.....	10.00
Supplement to Volume I (Botany).....	3.50
Volume I (without supplement), sold only with a complete file of section A, B, or C.....	6.50

Publications sent in exchange for the Philippine Journal of Science should be addressed: Library, Bureau of Science, Manila, P. I.

Subscriptions may be sent to the BUSINESS MANAGER, Philippine Journal of Science, Bureau of Science, Manila, P. I., or to any of the agents listed on the inside pages of this cover.

BOOK

JAN 25 1961
UNIV. OF MICH.
LIBRARY

UNIVERSITY OF MICHIGAN

3 9015 03543 0357

