

S. HRG. 108-868

**REVIEW OF DEPARTMENT OF DEFENSE
DETENTION AND INTERROGATION OPERATIONS**

HEARINGS

BEFORE THE

COMMITTEE ON ARMED SERVICES

UNITED STATES SENATE

ONE HUNDRED EIGHTH CONGRESS

SECOND SESSION

—————
MAY 7, 11, 19; JULY 22; SEPTEMBER 9, 2004
—————

Printed for the use of the Committee on Armed Services



**REVIEW OF DEPARTMENT OF DEFENSE DETENTION AND
INTERROGATION OPERATIONS**

**REVIEW OF DEPARTMENT OF DEFENSE
DETENTION AND INTERROGATION OPERATIONS**

HEARINGS

BEFORE THE

COMMITTEE ON ARMED SERVICES

UNITED STATES SENATE

ONE HUNDRED EIGHTH CONGRESS

SECOND SESSION

—————
MAY 7, 11, 19; JULY 22; SEPTEMBER 9, 2004
—————

Printed for the use of the Committee on Armed Services



U.S. GOVERNMENT PRINTING OFFICE

96-600 PDF

WASHINGTON : 2005

For sale by the Superintendent of Documents, U.S. Government Printing Office
Internet: bookstore.gpo.gov Phone: toll free (866) 512-1800; DC area (202) 512-1800
Fax: (202) 512-2250 Mail: Stop SSOP, Washington, DC 20402-0001

COMMITTEE ON ARMED SERVICES

JOHN WARNER, Virginia, *Chairman*

JOHN McCAIN, Arizona	CARL LEVIN, Michigan
JAMES M. INHOFE, Oklahoma	EDWARD M. KENNEDY, Massachusetts
PAT ROBERTS, Kansas	ROBERT C. BYRD, West Virginia
WAYNE ALLARD, Colorado	JOSEPH I. LIEBERMAN, Connecticut
JEFF SESSIONS, Alabama	JACK REED, Rhode Island
SUSAN M. COLLINS, Maine	DANIEL K. AKAKA, Hawaii
JOHN ENSIGN, Nevada	BILL NELSON, Florida
JAMES M. TALENT, Missouri	E. BENJAMIN NELSON, Nebraska
SAXBY CHAMBLISS, Georgia	MARK DAYTON, Minnesota
LINDSEY O. GRAHAM, South Carolina	EVAN BAYH, Indiana
ELIZABETH DOLE, North Carolina	HILLARY RODHAM CLINTON, New York
JOHN CORNYN, Texas	MARK PRYOR, Arkansas

JUDITH A. ANSLEY, *Staff Director*

RICHARD D. DEBOBES, *Democratic Staff Director*

CONTENTS

CHRONOLOGICAL LIST OF WITNESSES

ALLEGATIONS OF MISTREATMENT OF IRAQI PRISONERS

MAY 7, 2004

	Page
Rumsfeld, Hon. Donald H., Secretary of Defense	5
Myers, Gen. Richard B., USAF, Chairman, Joint Chiefs of Staff	11
Smith, Lt. Gen. Lance L., USAF, Deputy Commander, United States Central Command	13
Brownlee, Hon. Les, Acting Secretary of the Army	15
Schoomaker, Gen. Peter J., USA, Chief of Staff of the Army	16

ALLEGATIONS OF MISTREATMENT OF IRAQI PRISONERS

MAY 11, 2004

Cambone, Hon. Stephen A., Under Secretary of Defense for Intelligence	96
Smith, Lt. Gen. Lance L., USAF, Deputy Commander, United States Central Command	102
MG Antonio M. Taguba, USA, Deputy Commanding General for Support, Coalition Forces Land Component Command	102

CONTINUE TO RECEIVE TESTIMONY ON ALLEGATIONS OF MISTREATMENT OF IRAQI PRISONERS

MAY 11, 2004

Alexander, LTG Keith B., USA, Deputy Chief of Staff, G-2; Accompanied by MG Ronald L. Burgess, Jr., USA, Deputy Chief of Staff, J-2; and MG Thomas J. Romig, USA, Judge Advocate General	391
--	-----

ALLEGATIONS OF MISTREATMENT OF IRAQI PRISONERS

MAY 19, 2004

Abizaid, GEN John P., USA, Commander, United States Central Command ...	565
Sanchez, LTG Ricardo S., USA, Commander, Multi-National Force—Iraq	568
Miller, MG Geoffrey D., USA, Deputy Commander for Detainee Operations, Multi-National Force—Iraq	574
Warren, COL Marc L., Staff Judge Advocate, CJTF-7	574

IV

Page

THE DEPARTMENT OF THE ARMY INSPECTOR GENERAL REPORT ON DETENTION
OPERATION DOCTRINE AND TRAINING

JULY 22, 2004

Brownlee, Hon. Les, Acting Secretary of the Army; Accompanied by GEN Peter J. Schoomaker, USA, Chief of Staff of the Army; and LTG Paul T. Mikolashek, USA, Inspector General of the Army	680
---	-----

THE INVESTIGATION OF THE 205TH MILITARY INTELLIGENCE BRIGADE AT ABU
GHRAIB PRISON, IRAQ

SEPTEMBER 9, 2004

Kern, GEN Paul J., USA, Commanding General, United States Army Materiel Command; Accompanied by LTG Anthony R. Jones, USA, Deputy Commanding General, Chief of Staff, United States Army Training and Doctrine Command; MG R. Steven Whitcomb, USA, Special Assistant to the Commander, United States Central Command; MG George R. Fay, USA, Deputy Commander, United States Army Intelligence and Security Command; and MG Antonio M. Taguba, USA, Deputy Assistant Secretary of Defense for Reserve Affairs, Readiness, Training, and Mobilization	1049
---	------

THE REPORT OF THE INDEPENDENT PANEL TO REVIEW DEPARTMENT OF DEFENSE
DETENTION OPERATIONS

SEPTEMBER 9, 2004

Schlesinger, Dr. James R., Chairman, Independent Panel to Review Department of Defense Detention Operations	1313
Brown, Dr. Harold, Member, Independent Panel to Review Department of Defense Detention Operations	1317

ALLEGATIONS OF MISTREATMENT OF IRAQI PRISONERS

FRIDAY, MAY 7, 2004

U.S. SENATE,
COMMITTEE ON ARMED SERVICES,
Washington, DC.

The committee met, pursuant to notice, at 11:45 a.m. in room SD-106, Dirksen Senate Office Building, Senator John Warner (chairman) presiding.

Committee members present: Senators Warner, McCain, Roberts, Allard, Sessions, Collins, Talent, Chambliss, Graham, Dole, Cornyn, Levin, Kennedy, Byrd, Lieberman, Reed, Akaka, Bill Nelson, E. Benjamin Nelson, Dayton, Bayh, Clinton, and Pryor.

Other Senators present: Senator Bill Frist.

Committee staff members present: Judith A. Ansley, staff director; and Leah C. Brewer, nominations and hearings clerk.

Majority staff members present: Charles W. Alsup, professional staff member; L. David Cherington, counsel; Regina A. Dubey, research assistant; Ambrose R. Hock, professional staff member; Thomas L. MacKenzie, professional staff member; Elaine A. McCusker, professional staff member; Lucian L. Niemeyer, professional staff member; Paula J. Philbin, professional staff member; Lynn F. Rusten, professional staff member; Joseph T. Sixeas, professional staff member; Scott W. Stucky, general counsel; and Richard F. Walsh, counsel.

Minority staff members present: Richard D. DeBobes, Democratic staff director; Kenneth M. Crosswalt, professional staff member; Evelyn N. Farkas, professional staff member; Richard W. Fieldhouse, professional staff member; Jeremy L. Hekhuis, professional staff member; Gerald J. Leeling, minority counsel; Peter K. Levine, minority counsel; Michael J. McCord, professional staff member; William G.P. Monahan, minority counsel; and Arun A. Seraphin, professional staff member.

Staff assistants present: Michael N. Berger, Bridget Ward, Nicholas W. West, and Pendred K. Wilson.

Committee members' assistants present: Cord Sterling and James B. Kadtke, assistants to Senator Warner; Christopher J. Paul, assistant to Senator McCain; Mark Powers, assistant to Senator Inhofe; Darren M. Dick, assistant to Senator Roberts; Arch Galloway II, assistant to Senator Sessions; Derek J. Maurer, assistant to Senator Collins; Lindsey R. Neas, assistant to Senator Talent; Clyde A. Taylor IV, assistant to Senator Chambliss; Aleix Jarvis and Meredith Moseley, assistants to Senator Graham; Christine O. Hill, assistant to Senator Dole; Russell J. Thomasson, assistant

to Senator Cornyn; Sharon L. Waxman and Mieke Y. Eoyang, assistants to Senator Kennedy; Christina Evans and Erik Raven, assistants to Senator Byrd; Frederick M. Downey, assistant to Senator Lieberman; Elizabeth King, assistant to Senator Reed; Davelyn Noelani Kalipi, assistant to Senator Akaka; William K. Sutey and Dan Shapiro, assistants to Senator Bill Nelson; Eric Pierce, assistant to Senator Ben Nelson; William Todd Houchins, assistant to Senator Dayton; Todd Rosenblum and Rashid Hallaway, assistants to Senator Bayh; Andrew Shapiro, assistant to Senator Clinton; and Terri Glaze, assistant to Senator Pryor.

**OPENING STATEMENT OF SENATOR JOHN WARNER,
CHAIRMAN**

Chairman WARNER. The Committee on Armed Services meets today in the first of a series of hearings to receive testimony regarding the mistreatment of Iraqi prisoners by some—I repeat, some—elements and certain personnel of the Armed Forces of the United States in violation of U.S. and international laws.

Testifying before us today is the Secretary of Defense, the Honorable Donald Rumsfeld. He is joined by the Chairman of the Joint Chiefs of Staff, General Richard Myers; Acting Secretary of the Army, Les Brownlee; Army Chief of Staff, General Peter Schoomaker; and Central Command (CENTCOM) Deputy Commander, Lieutenant General Lance Smith. We welcome each of you today.

I have had the privilege of being associated with, and, more importantly, learning from, the men and women of the Armed Forces for close to 60 years of my life, and I can say that the facts I now have, from a number of sources, represent to me as serious an issue of military misconduct as I have ever observed. These reports could also seriously affect this country's relationships with other nations, the conduct of the war against terrorism, and place in jeopardy the men and women of the Armed Forces wherever they are serving in the world.

This mistreatment of prisoners represents an appalling and totally unacceptable breach of military regulations and conduct. Most significantly, the replaying of these images day after day throughout the Middle East, and indeed the world, has the potential to undermine the substantial gains towards the goal of peace and freedom in various operation areas of the world, most particularly Iraq, and the substantial sacrifice by our forces, as well as those of our allies, in the war on terror.

Let me be as clear as one Senator can be. This is not the way for anyone who wears the uniform of the United States of America to conduct themselves. This degree of breakdown in military leadership and discipline represents an extremely rare—and I repeat, rare—chapter in the otherwise proud history of the Armed Forces of the United States. It defies common sense. It contradicts all the values we Americans learn, beginning in our homes.

Members of the committee, as we conduct this hearing, I urge you that we take every care that our actions, our words, and our individual and collective conduct in this hearing not reflect unfairly on the 99.9 percent of our uniformed personnel who are performing

remarkable tasks and, in some cases, making the ultimate sacrifice of life and limb to win the global war on terrorism.

Each of us on the committee has nothing but the strongest support for our brave men and women in uniform and their families. What we seek for the American people through this and following hearings, is only to strengthen and honor their efforts, not in any way to detract from them and their accomplishments.

I would point out that while some systems have failed, we are here today because of a courageous enlisted man and his lieutenant, whose American values compelled them to step forward and inform their superiors. They did the right thing. As this committee performs its constitutional duties in hearings and oversight, we are working in the same spirit as those two soldiers.

Questions before us today are: Who knew what, and when? What did they do about it? Why were Members of Congress not properly and adequately informed?

In my 25 years on this committee, I have received hundreds of calls, day and night, from all levels, uniformed and civilian, of the Department of Defense (DOD), when they, in their judgment, felt it was necessary. I'd dare say that other members on this committee have experienced the same courtesy. I did not receive such a call in this case, and yet I think the situation was absolutely clear and required it, not only to me, but to my distinguished ranking member and other members of this committee.

Members of the committee, our central task here today is to get all the facts in this difficult situation, no matter where they lead, no matter how embarrassing they may be, so that we can assess our response and, in the end, make sure that such dereliction of duty as in this case never happens again in the proud history of our country.

Senator Levin.

STATEMENT OF SENATOR CARL LEVIN

Senator LEVIN. Thank you, Mr. Chairman.

The abuses that were committed against prisoners in U.S. custody at the Abu Ghraib prison in Iraq dishonored our military and our Nation, and they made the prospects for success in Iraq even more difficult than they already are. Our troops are less secure and our Nation is less secure because these depraved and despicable actions will fuel the hatred and fury of those who oppose us.

General Taguba's investigation, as reported, paints an alarming picture of abuse and humiliation of Iraqi prisoners. It has enraged people here at home and throughout the civilized world. Humiliating and sexually abusing prisoners has nothing to do with the effective internment or interrogation of prisoners. In fact, such actions are counterproductive to those goals.

As we seek to bring stability and democracy to Iraq and to fight terrorism globally, our greatest asset as a Nation is the moral values that we stand for. Those values have been compromised.

To begin the process of restoring them, the people involved, who carried out or who authorized or suggested that we should "loosen prisoners up" or, "make sure they get the treatment" must be held accountable. So must anyone up the chain of command be held accountable who had command responsibility over the interrogation

and security of prisoners, and who knew, or should have known, of these abuses and looked the other way.

General Taguba's finding that, "personnel assigned to the 372nd Military Police (MP) Company were directed to change facility procedures to set the conditions for military intelligence interrogations," is bolstered by pictures that suggest that the sadistic abuse was part of an organized and conscious process of intelligence-gathering. In other words, those abusive actions do not appear to be aberrant conduct by individuals, but part of a conscious method of extracting information. If true, the planners of this process are at least as guilty as those who carried out the abuses.

The President's legal counsel, Alberto Gonzalez, reportedly wrote, in a memorandum, that the decision to avoid invoking the Geneva Conventions "preserves flexibility" in the war on terrorism. Belittling or ignoring the Geneva Conventions invites our enemies to do the same, and increases the danger to our military service men and women. It also sends a disturbing message to the world that America does not feel bound by internationally accepted standards of conduct.

The findings of General Taguba's report, as reported on a public Web site, raise a number of disturbing issues. For example, how far up the chain was there implicit or explicit direction or approval or knowledge of these prisoner abuses? Why was a joint interrogation and detention facility at Abu Ghraib established in a way which led to the subordination of the MP brigade to the military intelligence unit conducting interrogation activities? What was the role played by the military intelligence, the Central Intelligence Agency (CIA), and any other intelligence units in requesting or suggesting abusive activities? How is it in our Nation's interest to have civilian contractors, rather than military personnel, performing vital national security functions such as prisoner interrogations in a war zone? When soldiers break the law or fail to follow orders, commanders can hold them accountable for their misconduct. Military commanders don't have the same authority over civilian contractors.

Finally, Secretary Rumsfeld and General Myers, I join our chairman in expressing deep dismay that when you briefed Senators in a classified session last week on events in Iraq, just hours before the story broke on television, you made no reference to the impending revelations. Executive branch consultation with Congress is not supposed to be an option, but a longstanding and fundamental responsibility.

It is essential that our Nation, at the highest levels, apologize directly to the victims and to the Iraqi people, as a whole, for these actions. But words alone are not sufficient. Prompt and decisive action, which establishes responsibility and holds people accountable, is essential here. It will also, hopefully, convince the world that our free and open society does not condone, and will not tolerate, this depraved behavior.

Chairman WARNER. I'll ask our witnesses to rise. [Witnesses sworn.]

The complete statements of all witnesses will be placed into the record. The committee will now receive the opening remarks of the Secretary, followed by the Chairman of the Joint Chiefs. I'm not

certain if others desire some recognition for opening remarks; if so, indicate to the chair. Then we'll go into a 6-minute round of questions by each member.

Mr. Secretary.

STATEMENT OF HON. DONALD H. RUMSFELD, SECRETARY OF DEFENSE

Secretary RUMSFELD. Mr. Chairman, members of the committee, in recent days there has been a good deal of discussion about who bears responsibility for the terrible activities that took place at Abu Ghraib. These events occurred on my watch. As Secretary of Defense, I am accountable for them, and I take full responsibility. It's my obligation to evaluate what happened, to make sure that those who have committed wrongdoing are brought to justice, and to make changes, as needed, to see that it doesn't happen again.

I feel terrible about what happened to these Iraqi detainees. They're human beings, and they were in U.S. custody. Our country had an obligation to treat them right. We did not, and that was wrong. So to those Iraqis who were mistreated by members of the U.S. Armed Forces, I offer my deepest apology. It was inconsistent with the values of our Nation. It was inconsistent with the teachings of the military to the men and women of the Armed Forces. It was certainly fundamentally un-American.

Further, I deeply regret the damage that has been done. First, to the reputation of the honorable men and women of the Armed Forces, who are courageously, responsibly, and professionally defending our freedoms across the globe. They are truly wonderful human beings, and their families and their loved ones can be enormously proud of them. Second, to the President, Congress, and the American people; I wish I had been able to convey to them the gravity of this before we saw it in the media. Finally, to the reputation of our country.

The photographic depictions of the U.S. military personnel that the public has seen have offended and outraged everyone in the DOD. If you could have seen the anguished expressions on the faces of those in our Department upon seeing those photos, you would know how we feel today.

It's important for the American people and the world to know that while these terrible acts were perpetrated by a small number of U.S. military personnel, they were also brought to light by the honorable and responsible actions of other military personnel.

There are many who did their duty professionally, and we should mention that, as well. First, Specialist Joseph Darby, who alerted the appropriate authorities that abuses were occurring. Second, those in the military chain of command who acted promptly, on learning of those abuses, by initiating a series of investigations—criminal and administrative—to assure that abuses were stopped and that the responsible chain of command was relieved and replaced.

Having said that, all the facts that may be of interest are not yet in hand. In addition to the Taguba Report, there are other investigations underway, and we'll be discussing those today. Because all the facts are not in hand, there will be corrections and clarifications to the record as more information is learned.

From the witnesses, you will be told the sequence of events and investigations that have taken place since the activities first came to light. I want to inform you of the measures underway to improve our performance in the future.

Before I do that, let me say that each of us at this table is either in the chain of command or has senior responsibilities in the DOD. This means that anything we say publicly could have an impact on the legal proceedings against those accused of wrongdoing in this matter. So please understand that if some of our responses to questions are measured, it is to assure that pending cases are not jeopardized by seeming to exert command influence, and that the rights of any accused are protected.

Now, let me tell you the measures we're taking to deal with this issue. First, to ensure we have a handle on the scope of this catastrophe, I will be announcing today the appointment of several senior former officials who are being asked to examine the pace, the breadth, the thoroughness of the existing investigations, and to determine whether additional investigations or studies need to be initiated. They're being asked to report their findings within 45 days of taking up their duties. I'm confident that these distinguished individuals will provide a full and fair assessment of what has been done thus far, and recommend whether further steps may be necessary.

[Clarifying information provided by the DOD follows:]

Charter for Independent Panel to Review DOD Detention Operations was signed on May 12, 2004. It allots a timeframe to provide advice "preferably within 45 days" after beginning the review. The panel has announced that it will present its final report on August 18, 2004, with the caveat that it could be modified at a later date to reflect the results of reports or investigations completed after that date.

Secretary RUMSFELD. Second, we need to review our habits and our procedures. One of the things we've tried to do in the DOD since September 11 is to try to get the Department to adjust our procedures and processes to reflect that we're in a time of war and that we're in the information age. For the past 3 years, we've looked for areas where adjustments were needed, and we've made a great many adjustments. Regrettably, we've now found another area where adjustments may be needed.

Let me be clear. I failed to recognize how important it was to elevate a matter of such gravity to the highest levels, including the President and the Members of Congress.

Third, I'm seeking a way to provide appropriate compensation to those detainees who suffered such grievous and brutal abuse and cruelty at the hands of a few members of the United States Armed Forces. It's the right thing to do.

I wish we had known more, sooner, and been able to tell you more, sooner. But we didn't. Today, we'll have a full discussion of these terrible acts, but first let's take a step back for a moment. Within the constraints imposed on those of us in the chain of command, I have a few additional words.

First, beyond abuse of prisoners, there are other photos that depict incidents of physical violence towards prisoners, acts that can only be described as blatantly sadistic, cruel, and inhuman. Second, there are many more photographs and, indeed, some videos. Congress and the American people and the rest of the world need to

know this. In addition, the photos give these incidents a vividness—indeed, a horror—in the eyes of the world. Mr. Chairman, that’s why this hearing today is important. That’s why the actions we take in the days and weeks ahead are so important.

However terrible the setback, this is also an occasion to demonstrate to the world the difference between those who believe in democracy and in human rights, and those who believe in rule by terrorist code. We value human life. We believe in individual freedom and in the rule of law. For those beliefs, we send men and women of the Armed Forces abroad to protect that right for our own people and to give others, who aren’t Americans, the hope of a future of freedom. Part of that mission, part of what we believe in, is making sure that when wrongdoings or scandals do occur, that they’re not covered up, but they are exposed, they are investigated, and the guilty are brought to justice.

Mr. Chairman, I know you join me today in saying to the world, “Judge us by our actions. Watch how Americans, watch how a democracy, deals with wrongdoing and with scandal and the pain of acknowledging and correcting our own mistakes and our own weaknesses.”

After they have seen America in action, then ask those who teach resentment and hatred of America if our behavior doesn’t give the lie to the falsehood and the slander they speak about our people and about our way of life. Ask them if the resolve of Americans in crisis and difficulty and, yes, in the heartbreak of acknowledging the evil in our midst, doesn’t have meaning far beyond their hatred.

Above all, ask them if the willingness of Americans to acknowledge their own failures before humanity doesn’t light the world as surely as the great ideas and beliefs that made this Nation a beacon of hope and liberty for all who strive to be free.

We know what the terrorists will do. We know they will try to exploit all that is bad, and try to obscure all that is good. That’s their nature. That’s the nature of those who think they can kill innocent men, women, and children to gratify their own cruel will to power. We say to the world, “We will strive to do our best, as imperfect as it may be.”

Thank you, Mr. Chairman.

[The prepared statement of Secretary Rumsfeld follows:]

PREPARED STATEMENT BY HON. DONALD H. RUMSFELD

Mr. Chairman, members of the committee—thank you for the opportunity to testify today.

In recent days, there has been a good deal of discussion about who bears responsibility for the terrible activities that took place at Abu Ghraib. These events occurred on my watch. As Secretary of Defense, I am accountable for them. I take full responsibility. It is my obligation to evaluate what happened, to make sure those who have committed wrongdoing are brought to justice, and to make changes as needed to see that it doesn’t happen again.

I feel terrible about what happened to these Iraqi detainees. They are human beings. They were in U.S. custody. Our country had an obligation to treat them right. We didn’t do that. That was wrong.

To those Iraqis who were mistreated by members of the U.S. Armed Forces, I offer my deepest apology. It was un-American. It was inconsistent with the values of our Nation.

Further, I deeply regret the damage that has been done:

- First, to the reputation of the honorable men and women of our Armed Forces who are courageously, skillfully and responsibly defending our freedom across the globe. They are truly wonderful human beings, and their families and loved ones can be enormously proud of them.
- Second, to the President, Congress, and the American people. I wish we had been able to convey to them the gravity of this was before we saw it in the media;
- Third, to the Iraqi people, whose trust in our coalition has been shaken; and finally
- To the reputation of our country.

The photographic depictions of U.S. military personnel that the public has seen have unquestionably offended and outraged everyone in the Department of Defense (DOD).

If you could have seen the anguished expressions on the faces of those of us in the Department upon seeing the photos, you would know how we feel today.

We take this seriously. It should not have happened. Any wrongdoers need to be punished, procedures evaluated, and problems corrected.

It's important for the American people and the world to know that while these terrible acts were perpetrated by a small number of the U.S. military, they were also brought to light by the honorable and responsible actions of other military personnel. There are many who did their duty professionally and we should mention that as well:

- First the soldier, Specialist Joseph Darby, who alerted the appropriate authorities that abuses of detainees were occurring. My thanks and appreciation to him for his courage and his values.
- Second, those in the military chain of command who acted promptly upon learning of those activities by initiating a series of investigations—criminal and administrative—to ensure that the abuses were stopped, that the responsible chain of command was relieved and replaced, and that the Uniform Code of Military Justice (UCMJ) was followed;
- Third, units singled out for praise in General Taguba's report for the care they provided detainees in their custody and their intolerance of abuses by others;
- Finally, the Central Command (CENTCOM) chain of command for taking action and publicly announcing to the world that investigations of abuse were underway.

The American people and members of the committee deserve an accounting of what has happened and what's being done to fix it.

Gathered today are the senior military officials with responsibility in the care and treatment of detainees.

The responsibility for training falls to the U.S. Army. The responsibility for the actions and conduct of forces in Iraq falls to the combatant commander. The ultimate responsibility for the DOD rests with me.

Each of us has had a strong interest in getting the facts out to the American people.

We want you to know the facts. I want you to have all the documentation and the data you require. If some material is classified, we will ensure members get an opportunity to see it privately.

Having said that, all the facts that may be of interest are not yet in hand. In addition to the Taguba Report, there are other investigations underway. We will make the results of these investigations available to you. But because all the facts are not in hand, there will be corrections and clarifications to the record as more information is learned. If we have something to add later, we'll do so. If we find something that we've said that needs to be corrected, we'll correct it.

From the other witnesses here, you will be told the sequence of events and investigations that have taken place since these activities first came to light.

What I want to do is inform you of the measures underway to remedy some of the damage done and to improve our performance in the future.

Before I do that, let me make one further note: As members of this committee are aware, each of us at this table is either in the chain of command or has senior responsibilities in the DOD. This means that anything we say publicly could have an impact on legal proceedings against those accused of wrongdoing in this matter. Our responsibility at this hearing, and in our public comments, is to conduct ourselves consistent with that well known fact. So please understand that if some of our responses are measured, it is to ensure that pending cases are not jeopardized by seeming to exert "command influence" and that the rights of any accused are protected.

Now let me tell you the measures we are taking to deal with this issue.

When this incident came to light and was reported within the chain of command, we took several immediate actions. These will be discussed in detail by others here today, but let me highlight them.

- General Sanchez launched a criminal investigation immediately.
- He then asked for an administrative review of procedures at the Abu Ghraib facility. That is the so-called Taguba Report.

These two investigations have resulted thus far in criminal or administrative actions against at least 12 individuals, including the relief of the prison chain of command and criminal referrals of several soldiers directly involved in abuse.

- The Army also launched an Inspector General (IG) review of detainee operations throughout Afghanistan and Iraq. That review continues.
- The Army has initiated an investigation of Reserve training with respect to military intelligence (MI) and police functions.
- General Sanchez also asked for an Army Intelligence review of the circumstances discussed in General Taguba's report and that is ongoing.
- I also asked the Navy IG to review procedures at Guantanamo and the Charleston Naval Brig.

As these investigations mature, we will endeavor to keep you informed. But there is more to be done.

First, to ensure we have a handle on the scope of this catastrophe, I will be announcing today the appointment of several senior former officials who are being asked to examine the pace, breadth, and thoroughness of the existing investigations, and to determine whether additional investigations need to be initiated.

[Clarifying information provided by the DOD follows:]

Charter for Independent Panel to Review DOD Detention Operations was signed on May 12, 2004. It allots a timeframe to provide advice "preferably within 45 days" after beginning the review. The panel has announced that it will present its final report on August 18, 2004, with the caveat that it could be modified at a later date to reflect the results of reports or investigations completed after that date.

They are being asked to report their findings within 45 days of taking up their duties. I am confident these distinguished individuals will provide a full and fair assessment of what has been done thus far—and recommend whether further steps may be necessary.

I will encourage them to meet with Members of Congress to keep them apprised of their progress. I look forward to their suggestions and recommendations.

Second, we need to review our habits and procedures. One of the things we've tried to do since September 11 is to get the DOD to adjust its habits and procedures at a time of war, and in the information age. For the past 3 years, we have looked for areas where adjustments were needed, and regrettably, we have now found another one.

Let me be clear. I failed to identify the catastrophic damage that the allegations of abuse could do to our operations in the theater, to the safety of our troops in the field, the cause to which we are committed. When these allegations first surfaced, I failed to recognize how important it was to elevate a matter of such gravity to the highest levels, including leaders in Congress. Nor did we anticipate that a classified investigation report that had not yet been delivered to the senior levels of the DOD would be given to the media. That was my failing.

In the future, we will take whatever steps are necessary to elevate to the appropriate levels charges of this magnitude.

Third, I am seeking a way to provide appropriate compensation to those detainees who suffered grievous and brutal abuse and cruelty at the hands of a few members of the U.S. military. It is the right thing to do. I'm told we have the ability to do so. So we will—one way or another.

One of the great strengths of our Nation is its ability to recognize failures, deal with them, and to strive to make things better. Indeed, the openness with which these problems are being dealt is one of the strengths of our free society. Democracies are imperfect, because they are made up of human beings who are, by our nature, imperfect. Of course, we wish that every person in our Government and our Armed Forces would conduct themselves in accordance with the highest standards of ethics. But the reality is some do not.

One mistake we have made during our initial investigation into these charges, for example, was failing to sufficiently call to your attention the information made public in the CENTCOM press release regarding the investigations they had initiated back in January. We also failed to sufficiently call your attention and brief you on the preliminary findings of the criminal investigation announced on March 20 by

General Kimmitt. I am advised the Army has had periodic meetings to inform congressional staffs.

There are indications that the information provided was penetrating at some level, however. On January 20, for example, CNN reported that a criminal investigation division (CID) investigation was being conducted into allegations of detainee abuse at Abu Ghraib, and mentioned the possible existence of photographs taken of detainees.

Nonetheless, I know that we did not fully brief you on this subject along the way and we should have done so.

I wish we would have known more sooner and been able to tell you more sooner. But we didn't. For that, I apologize.

We need to discuss a better way to keep you informed about matters of such gravity in the future.

The fact that abuses take place—in the military, in law enforcement, and in our society—is not surprising. But the standard by which our country and our Government should be judged is not by whether abuses take place, but rather how our Nation deals with them. We are dealing with them forthrightly. These incidents are being investigated and any found to have committed crimes or misconduct will receive the appropriate justice. Most of the time, at least, the system works.

None of this is meant to diminish the gravity of the recent situation at Abu Ghraib. To the contrary, that is precisely why these abuses are so damaging—because they can be used by the enemies of our country to undermine our mission and spread the false impression that such conduct is the rule and not the exception—when, in fact, the opposite is true.

Which is why it is so important that we investigate them publicly and openly, and hold people accountable in similar fashion. That is exactly what we are doing.

Questions

When we first were told about these activities and saw those photographs, I and everyone at this table was as shocked and stunned as you were.

In the period since, a number of questions have been raised—here in Congress, in the media, and by the public. Let me respond to some of them.

Some have asked: Why weren't those charged with guarding prisoners properly trained?

If one looks at the behavior depicted in those photos, it is fair to ask: what kind of training could one possibly provide that would stop people from doing that? Either you learn that in life, or you don't. If someone doesn't know that doing what is shown in those photos is wrong, cruel, brutal, indecent, and against American values, I am at a loss as to what kind of training could be provided to teach them.

The fact is, the vast majority of the people in the United States Armed Forces are decent, honorable individuals who know right from wrong, and conduct themselves in a manner that is in keeping with the spirit and values of our country. There is only a very small minority who do not.

Some have asked: Hasn't a climate allowing for abuses to occur been created because of a decision to "disregard" the Geneva Conventions?

No. Indeed, the U.S. Government recognized that the Geneva Conventions apply in Iraq, and the Armed Forces are obliged to follow them. DOD personnel are trained in the law of war, including the Geneva Conventions. Doctrine requires that they follow those rules and report, investigate, and take corrective action to remedy violations.

We did conclude that our war against al Qaeda is not governed precisely by the Conventions, but nevertheless announced that detained individuals would be treated consistent with the principles of the Geneva Conventions.

Some have asked: Can we repair the damage done to our credibility in the region?

I hope so and I believe so. We have to trust that in the course of events the truth will eventually come out. The truth is that the United States is a liberator, not a conqueror. Our people are devoted to freedom and democracy, not enslavement or oppression.

Every day, these men and women risk their lives to protect the Iraqi people and help them build a more hopeful future. They have liberated 25 million people; dismantled two terrorist regimes; and battled an enemy that shows no compassion or respect for innocent human life.

These men and women, and the families who love and support them, deserve better than to have their sacrifices on behalf of our country sullied by the despicable actions of a few. To that vast majority of our soldiers abroad, I extend my support and my appreciation for their truly outstanding service.

One final thought:

Today we'll have a full discussion of this terrible incident and I welcome that. But first, let's take a step back for a moment.

Within the constraints imposed on those of us in the chain of command, I want to say a few additional words.

First, beyond abuse of prisoners, we have seen photos that depict incidents of physical violence towards prisoners—acts that may be described as blatantly sadistic, cruel, and inhuman.

Second, the individuals who took the photos took many more.

The ramifications of these two facts are far reaching.

Congress and the American people and the rest of the world need to know this.

In addition, the photos give these incidents a vividness—indeed a horror—in the eyes of the world.

Mr. Chairman, that is why this hearing today is important. That is why the actions we take in the days and weeks ahead are so important.

Because however terrible the setback, this is also an occasion to demonstrate to the world the difference between those who believe in democracy and human rights and those who believe in rule by the terrorist code.

We value human life; we believe in their right to individual freedom and the rule of law.

For those beliefs we send the men and women in the Armed Forces abroad—to protect that right for our own people and to give millions of others who aren't Americans the hope of a future of freedom.

Part of that mission—part of what we believe in—is making sure that when wrongdoing or scandal occur that they are not covered up, but exposed, investigated, publicly disclosed—and the guilty brought to justice.

Mr. Chairman, I know you join me today in saying to the world: Judge us by our actions. Watch how Americans, watch how a democracy deals with wrongdoing and scandal and the pain of acknowledging and correcting our own mistakes and weaknesses.

After they have seen America in action, then ask those who preach resentment and hatred of America if our behavior doesn't give the lie to the falsehood and slander they speak about our people and way of life. Ask them if the resolve of Americans in crisis and difficulty—and, yes, the heartache of acknowledging the evil in our midst—doesn't have meaning far beyond their code of hatred.

Above all, ask them if the willingness of Americans to acknowledge their own failures before humanity doesn't light the world as surely as the great ideas and beliefs that first made this Nation a beacon of hope and liberty to all who strive to be free.

We know what the terrorists will do. We know they will try to exploit all that is bad to obscure all that is good. That is the nature of evil. That is the nature of those who think they can kill innocent men, women and children to gratify their own cruel will to power.

We say to the enemies of humanity and freedom: Do your worst, because we will strive to do our best. I thank you Mr. Chairman. My colleagues each have a brief statement.

Chairman WARNER. Thank you, Mr. Secretary.

You and I have had the privilege to know each other for many years. We've enjoyed a close working relationship. I want to say, I found that statement to be strong and, in every sense, heartfelt by you.

Secretary RUMSFELD. Thank you.

Chairman WARNER. General Myers.

**STATEMENT OF GEN. RICHARD B. MYERS, USAF, CHAIRMAN,
JOINT CHIEFS OF STAFF**

General MYERS. Mr. Chairman and Senator Levin, I would like to express my deep regret at being here under these circumstances. The incidents of prisoner abuse that occurred at Abu Ghraib prison are absolutely appalling. The actions of those involved are unconscionable and absolutely unacceptable.

Since Brigadier General Kimmitt's public announcement of the allegations back in January, the commanders' response to the problems highlighted in these investigations has been timely and thor-

ough. Just as a backdrop, we must also realize that our commanders had been handling some enormous challenges in Iraq, including the fighting that had intensified in Fallujah and in Najaf, the temporary plus-up of troops, which was a decision that was pending, and the departure of the Spanish brigade, all at the same time that they were dealing with some of these reports. Despite these extraordinary events, our commanders did exactly the right thing in a timely manner. I have great confidence in them, as should the American public and the citizens of Iraq.

I've been receiving regular updates since the situation developed in January, and I've been involved in corrective actions and personally recommended specific steps. Again, I'm confident that the commanders are doing the right things.

One of the military's greatest strengths comes from the fact that we hold our service men and women accountable for their actions. Our military justice system works very well. I took an oath to support the Constitution, and with that comes the responsibility to ensure that all military members enjoy the full protections of our Constitution, to include the due process of a fair judicial system. After all, it is respect for the rule of law that we're trying to teach and instill in places like Afghanistan and Iraq. So, as the Secretary said, we are now in the middle of a judicial process regarding detainee abuse. Because of my position, I have to be careful to not say anything that can be interpreted as direction or pressure for a certain outcome in any of these cases.

Moreover, we have to understand that a fair judicial system takes time to work. I know you all understand that. No one is stalling or covering up information, but it's absolutely essential to protect the integrity of our judicial system. I have complete confidence in our military justice system. The accused will receive due process. Those found guilty will receive punishments based on their offenses.

When I spoke to Dan Rather, with whom I already had a professional association, concerning the "60 Minutes" story, I did so after talking to General Abizaid, and I did so out of concern for the lives of our troops.

The story about the abuse was already public, but we were concerned that broadcasting the actual pictures would further inflame the tense situation that existed then in Iraq, and further endanger the lives of coalition soldiers and hostages. Again, it's useful to remember the context here. We were in the midst of some very heavy fighting in Fallujah and other places in Iraq, and some 90 hostages had been taken. It was a very delicate situation that we were trying to resolve.

Since the story of the photographs was already public, I felt we were on good ground in asking him to hold off airing the actual photos. As we are now seeing, the photos are having a very real, very emotional worldwide impact. I would identify myself with the Secretary's remarks on having seen more of them than I wish to have seen. They have had quite an impact on me.

This situation is nothing less than tragic. The Iraqi people are trying to build a free and open society, and I regret they saw such a flagrant violation of the very principles that are the cornerstone of such a society.

I am also terribly saddened that the hundreds of thousands of service men and women who are serving, or who have served, so honorably in Iraq and Afghanistan and elsewhere would have their reputation tarnished and their accomplishments diminished by those few who don't uphold our military's values. I know our service men and women are all suffering unfairly with a collective sense of shame over what has happened. Their credibility will be restored day by day as they interact with the Iraqi people, and I'm confident that our dedicated service men and women will continue to prove worthy of the trust and respect of our Nation and of the world. We continue to be very proud of them. As always, I thank you, on their behalf, for your steadfast support.

Thank you.

Chairman WARNER. Thank you, General. That was a good statement.

Secretary Brownlee, do you wish to—

Mr. BROWNLEE. I think General Smith's going next.

Chairman WARNER. You defer to General Smith?

Secretary RUMSFELD. Yes, sir.

Chairman WARNER. Fine, thank you.

**STATEMENT OF LT. GEN. LANCE L. SMITH, USAF, DEPUTY
COMMANDER, UNITED STATES CENTRAL COMMAND**

General SMITH. Senator Warner, Senator Levin, members of the committee, I wish to start by thanking you for the opportunity to testify before this committee concerning the mistreatment of Iraqi detainees.

The more than 250,000 soldiers, sailors, airmen, and marines who have served in the CENTCOM area of responsibility (AOR) over the past year have faced numerous challenges in prosecuting the global war on terror and Operation Iraqi Freedom (OIF) and Operation Enduring Freedom (OEF). Throughout these operations, they have worked to better the lives of the people of Afghanistan and Iraq, to bring progress and stability to these countries. Their efforts, however, have been put at risk by the reprehensible actions of a few. These few have acted in a manner that is inconsistent with the proud history of the American soldier. There is no excuse for their actions, nor do I offer one. Their unprofessional and malicious conduct has caused considerable harm to our attempts to win the trust and confidence of the Iraqi people. Unfortunately, it has also facilitated the efforts of our enemy to malign our national intent and character, and gives weight to the charge of American hypocrisy.

When the allegations of abuse and improper conduct of U.S. forces against legally detained Iraqis were brought to light by a soldier on January 13, 2004, our leadership in Iraq prudently informed us of what they knew and immediately initiated a criminal investigation. That investigation has resulted in preferral of charges against six service members, three of which have, thus far, been referred to courts-martial, and we are still investigating further allegations of criminal misconduct.

At the request of the Commander, Joint Task Force 7 (CJTF-7) on January 24, CENTCOM directed the conduct of a broader administrative investigation, now known as the Taguba Report, with

the mandate to make a comprehensive examination of our detainee operations in Iraq in order to detect any systemic problems, and, if problems were identified, to take necessary steps to rectify the situation and hold accountable all those responsible who failed in their duties. That investigation is near completion, and we have already made significant progress in implementing its recommendations, but we have more ahead of us.

Information flow up and down the chain of command was timely, and will continue to be. Commanders regularly brief their superiors as these investigations progress. The first public release of information on the Criminal Investigation Division (CID) investigation happened in January, and was reported by the media. The interim results of the Taguba Report were briefed to me in late March as the investigation made its way through command channels en route to approval by the Coalition Force Land Component Commander on April 6, and formal adverse administrative action by the CJTF on May 1. The investigation is ongoing.

Some have asked why it took so long for the allegations to make it up the chain of command. One needs to look at this as a legal proceeding. Once the allegations were made, the investigation was initiated immediately. Evidence was gathered, people were questioned, and a number were removed from their posts. As with any prosecution, materials and evidence were kept within the investigatory chain, for obvious reasons: to maintain confidentiality, to protect individual rights, and to allow the investigation to proceed without danger of exposure to those being investigated.

The actions of the chain of command in Iraq in conducting the investigations connected with detainee abuse or mistreatment have been swift, circumspect, and proper. They have carefully uncovered facts, analyzed evidence, and gauged the context of the situation, all the while under the stress of ongoing combat operations, and ever mindful of protecting the rights of the accused. Commanders are taking action both to ensure justice is done and to ensure that this kind of deplorable conduct is never repeated.

With regards to the question of whether this abuse is systemic, the investigations underway should better inform us on that. At this point, we don't know, and that's part of what we're trying to determine by conducting investigations. When we have answers, we will provide them.

The Taguba Report, in fact, highlights three units for praise for their performance of military detention duties. That is a hopeful sign that these abuses are not widespread, and I don't believe they are.

The vast majority of coalition and U.S. forces have shown great humanity and restraint in this, and have acted with courage and compassion. The situation at Abu Ghraib is not representative of the conduct of U.S. and coalition forces. It is a distasteful and criminal aberration, and will absolutely not be tolerated. We deeply regret that these egregious actions occurred, and we are taking the necessary steps to preclude similar incidents in the future.

Thank you, Mr. Chairman.

Chairman WARNER. Thank you, General.

Secretary Brownlee, we need to move on, but we certainly recognize that you might have a few opening remarks.

Mr. BROWNLEE. Okay, sir. I'll go fast, sir.

Chairman WARNER. Thank you.

**STATEMENT OF HON. LES BROWNLEE, ACTING SECRETARY OF
THE ARMY**

Mr. BROWNLEE. Chairman Warner, Senator Levin, and distinguished members of the committee, I appreciate the opportunity to be here today to offer testimony on actions taken by the Army in response to the appalling abuse of detainees at Abu Ghraib prison in Iraq. I join the Secretary of Defense in apologizing to those detainees who were abused there.

Let me begin by outlining the range of investigations into detainee abuse. From December 2002 to present, the CID has conducted, or is continuing to conduct, investigations into 35 cases of abuse or death of detainees held in detention facilities in the CENTCOM theater. Twenty-five of these are death cases, and 10 involve assault. The CID investigates every death in our custody.

Of the 25 death investigations, the CID has determined that 12 deaths were due to natural or undetermined causes, 1 was justifiable homicide, and 2 were homicides. The 10 remaining deaths are still under investigation.

Additionally, 42 other potential cases of misconduct against civilians occurred outside the detention facilities and are currently under investigation by the Army CID or by the responsible units.

On February 10, 2004, I directed the Inspector General (IG) of the Army to conduct a functional analysis of the Department's internment, enemy-prisoner-of-war (POW), and detention policies, practices, and procedures. I directed this inspection to determine if there might be systemic problems relating to the planning, doctrine, or training in the detention facilities operating within the CENTCOM theater. Phase 1 of this assessment is oriented on current operations in the CENTCOM AOR, with assessment-team visits to 16 detention facilities. Phase 2 of the IG assessment will encompass visits to defense facilities worldwide, including previously-visited facilities, to ensure compliance to established standards.

Preliminary findings indicate that leaders and soldiers are aware of the requirement and expectation to treat detainees humanely, and that it is their duty to report incidents of abuse. To date, the majority of the abuse cases indicate the underlying cause has been twofold: an individual failure to adhere to basic standards of discipline, training, and Army values; and leadership failures to provide oversight and enforce standards.

To date, the Army has taken numerous actions to improve the training for MPs and military intelligence (MI) soldiers. The Army is retraining select MP soldiers to serve as correctional specialists. We have incorporated detainee lessons learned from operations in both Iraq and Afghanistan into the MP school curriculum, and have deployed MP training teams to our combat training centers. In response to a request from the CJTF-7, the Army deployed integrated multi-discipline mobile training teams to oversee and conduct comprehensive training in all aspects of detainee and confinement operations in-theater.

Additionally, the Chief of the Army Reserve has directed his IG to conduct a special assessment of training for Reserve personnel

on the law of war, detainee treatment, ethics, and leadership. All Reserve component MI soldiers are now required to mobilize at the intelligence school at Fort Huachuca so they can receive the latest instruction on tactical questioning before deploying.

Finally, the Army is improving the training of MP and MI personnel at our combat training centers by incorporating detainee holding situations into the tactical scenarios.

These improvements were initiated for the later-deploying OIF, or OIF-2 units, and will be fully implemented for all OIF-3 deploying units.

The reported acts of detainee abuse at Abu Ghraib are tragic and disappointing, and they stand in sharp contrast to the values of our Army and the Nation it serves. For these incidents to reflect negatively on the courage, sacrifice, and selfless service of the hundreds of thousands of dedicated men and women who have volunteered to serve our Nation in uniform would be a tragedy, as well. Our soldiers, over 300,000 of whom are deployed in over 120 countries around the world, most in Iraq and Afghanistan, have provided the opportunity for freedom and democracy for over 46 million people who have never experienced it before, while, at the same time, providing protection to the American people.

Mr. Chairman, we will find out how and why this happened, and ensure that those individuals determined to be responsible for these shameful and illegal acts of abuse are held accountable for their actions.

I appreciate this opportunity to appear before you today. I thank you and the members of this distinguished committee for your continuing support of the men and women in our Army, and I look forward to answering your questions.

Chairman WARNER. Secretary Brownlee, your statement is very helpful, and a significant contribution to this hearing.

General Schoomaker.

STATEMENT OF GEN. PETER J. SCHOOMAKER, USA, CHIEF OF STAFF OF THE ARMY

General SCHOOMAKER. Chairman Warner, Senator Levin, distinguished members of the committee, I'll be brief.

As the Chief of Staff of the Army, I am responsible for training and equipping our soldiers, as well as growing our Army leaders. I am also responsible for providing ready and relevant land power capabilities to the combatant commanders and the joint team. Although not in the operational chain of command, I am responsible for our soldiers' training and readiness; therefore, I take it personally when any of them fall short of our standards.

To put it in perspective, what we are dealing with are the actions of a few, as has been pointed out. These are conscious actions that are contrary to all that we stand for. This is not a training issue, but one of character and values. Our Army values of loyalty, duty, respect, selfless service, honor, integrity, and personal courage are taught to our soldiers from the moment that they enter the training base. There's no question that potential consequences are serious, but we must not forget that these are a few among a great many others who are serving with great honor and sacrifice, as has been pointed out.

We must be careful how we proceed, as it will affect the morale and the safety of a great majority of our soldiers who are meeting the standards and are daily placing themselves in harm's way. I promise you, they, too, take this personally.

I am reminded that, in the report by Major General Taguba, he spoke of several soldiers and units who were challenged by the same set of demanding circumstances at the same place, and they did what was right. The inexcusable behavior of a few is not representative of the courageous and compassionate performance of the overwhelming majority of our soldiers who serve with pride and honor.

We are currently undergoing an extensive investigation of every allegation. The system works, and will result in fairness and justice. We will also learn and adapt. Our Army has already taken corrective actions. Our soldiers are performing with distinction, and I am proud of them all. We owe them our confidence. Our Army is taking this very seriously, and will meet the standards that our Nation expects, as we have for 229 years.

Thank you.

Chairman WARNER. Thank you, General. That statement on leadership reflects your own strong record of leadership, and we're fortunate to have you at the helm of the United States Army today.

We'll proceed with questions now. Colleagues, recognizing that almost the full membership of the committee is present, the chair will have to cut the time to 5 minutes.

Mr. Secretary, I was particularly impressed by your phrase, "We're going to watch American democracy in action, as the President and all others address this problem swiftly, in accordance with the rule of law and American values." In the meantime, however, it's obvious to all of us that the impact of the facts of this case as they are unfolding is affecting our relationship with other nations, our foreign policy. So I ask you, what is that impact, as best you can assess it today? Second, will the impact of this situation affect, in any way, the transition that I and others support to take place on June 30? Will it have any impact on other nations in the coalition to consider their continued participation at this time, and the chances of adding additional nations? Lastly, does it have any impact on the force levels that you anticipate, together with your on-scene commanders of CENTCOM, in the near future?

Secretary RUMSFELD. Mr. Chairman, those are tough questions. I'm afraid no one has the ability to know precisely what will unfold. We have seen no shift in coalition countries, in answer to your first question.

About future coalition countries, I think the key determinative there is whether or not we are successful in getting an additional United Nations (U.N.) resolution, in which case I think we will get additional countries to participate. It certainly will not have any effect on the determination to have sovereign responsibility assumed by Iraqis by June 30.

I would just say one other thing. We have been enormously disadvantaged by false allegations and lies for the better part of a year—and, indeed, before that, with respect to Afghanistan—by terrorists and terrorist organizations alleging things that weren't true. So we have taken a beating in the world for things we were

not doing that were alleged to be done. Now we're taking a beating, understandably, for things that did, in fact, happen.

Chairman WARNER. Thank you, sir.

General MYERS. Mr. Chairman, if I could just add to that. I just returned from a North Atlantic Treaty Organization (NATO) Military Committee meeting, and had the chance to talk to several of the countries that have major military units inside Iraq. They were very strong, in every case, about seeing this through, and seemed undeterred by any of the recent events. They were looking forward, and we were talking about the future and about their steadfastness in seeing this mission through.

Chairman WARNER. General, I direct my next question to you, because the Department of the Army has been in the forefront. CENTCOM, as we all know, is composed of officers—men, women—of all branches of the Services. I would anticipate that you have consulted with your colleagues, not only on the Joint Chiefs, but particularly in CENTCOM, and that you are making, or have made and will continue to make, an assessment as to the possible personnel increase in the number of men and women of the Armed Forces, most particularly in Iraq, and perhaps elsewhere in the world. This story continues to reflect very deeply the thinking and actions of others.

General MYERS. Mr. Chairman, absolutely we will. We should not underestimate that impact. It was that impact of the pictures—the report of pictures was already out there. But the actual pictures possibly coming out on a news program, that prompted my call to try to delay their release. I thought those pictures, at that particular time, would have a particularly bad effect on our troops, perhaps resulting in death to our forces.

I think we have a lot of troops in Iraq right now, after talking to General Smith and others, that are probably walking with—they're involved in combat, but they're walking with their heads just a little bit lower right now because they have to bear the brunt of what their colleagues up in Abu Ghraib did. It's going to take, as General Schoomaker said, good leadership and everything else we can do to get them back up on the net, because they are engaged in some very important work.

As I said in my statement, I continue to think that the way we'll win their trust will be soldier by soldier, patrol by patrol, like we're winning the war over there, and we're just going to have to stay at it.

Chairman WARNER. Thank you. My time is expired.

Senator Levin.

Senator LEVIN. Thank you, Mr. Chairman.

Secretary Rumsfeld, I was struck by one of the photographs from the prison depicting three naked prisoners in a lump on the floor being overseen by a number of soldiers, while other soldiers in the cell block were assisting or were going about their business without any apparent interest in or concern about the obvious abusive treatment. It occurred to me that the conduct that we were witnessing and watching was not the aberrant conduct of a few individuals, but was part of an organized and conscious process to extract information.

This picture reinforces the Taguba Report, which quotes Sergeant Davis as saying that he witnessed prisoners in the MI hold section, Wing 1A, “being made to do various things that I would question, morally.” He quoted the MI folks as saying, “loosen the guy up for us, make sure he has a bad night, make sure he gets the treatment.” He further stated that the wing belonged to MI, and it appeared that MI personnel approved of the abuses.

Now, in the Taguba Report itself, General Taguba says the following, and this is his finding, that “military intelligence interrogators and other U.S. Government agency interrogators”—which I assume includes CIA—“actively requested that MP guards set physical and mental conditions for favorable interrogation of witnesses,” and that personnel assigned to the MP company and brigade were “directed to change facility procedures to set the conditions for military intelligence interrogations.”

My question to you is, what were those changes that were made, and was it proper to make changes of the kind that General Taguba refers to?

Secretary RUMSFELD. The conclusions you seem to have drawn in your question, Senator Levin, are issues that I believe are probably all being addressed in an investigation that was initiated last month. I think it’s called the Fay Investigation—possibly you, General Smith, who have been involved in this, would want to comment.

General SMITH. Sir, there has been an investigation that was initiated in mid-April by Major General Fay, and it is to look into exactly those allegations.

Senator LEVIN. All right.

Secretary Rumsfeld, would you agree that people who authorized, or suggested, or prompted the conduct depicted in the pictures that we’ve seen, as well as those who carried out the abuses, must be held accountable? That anybody who authorized, knew about, prompted, or suggested, in the Intelligence Community or otherwise, that conduct must be held accountable? That’s my very direct question to you.

Secretary RUMSFELD. The pictures I’ve seen depict conduct and behavior that is so brutal and so cruel and so inhumane that anyone engaged in it or involved in it would have to be brought to justice.

Senator LEVIN. Would that include anybody who suggested it, prompted it, or hinted at it directly or indirectly? I just want to know how far up this chain you’re going to go. Are you going to limit this to people who perpetrated it, or are we going to get to the people who may have suggested it or encouraged it?

Secretary RUMSFELD. That is exactly why the investigation was initiated, and that is why it’s being brought forward. We’ll find what their conclusions are, and I’m sure they will make recommendations with respect to prosecution.

Senator LEVIN. But in terms of the standard, does anybody who recommended or suggested, directly or indirectly, that conduct in order to extract information—in your judgment, if that occurred, are they also violative of our laws and standards?

Secretary RUMSFELD. Certainly, anyone who recommended the kind of behavior that I've seen depicted in those photos needs to be brought to justice.

Chairman WARNER. Thank you, Senator.

Senator LEVIN. My time is up. Thank you.

Chairman WARNER. Senator McCain.

Senator MCCAIN. Thank you, Mr. Secretary.

I come to this hearing with a deep sense of sorrow and grave concern. Sorrow after the shock and anger of seeing these pictures for the first time, that so many brave young Americans who are fighting and dying are under this cloud. I attended the memorial service of Pat Tillman, a brave American who sacrificed his life recently. He and others, unfortunately, at least in some way, are diminished by this scandal.

I'm gravely concerned that many Americans will have the same impulse I did when I saw these pictures, and that's to turn away from them. We risk losing public support for this conflict. As Americans turned away from the Vietnam War, they may turn away from this one unless this issue is resolved, with full disclosure, immediately.

With all due respect to investigations ongoing and panels being appointed, the American people deserve immediate and full disclosure of all relevant information so that we can be assured and comforted that something that we never believed could happen will never happen again.

Now, Mr. Secretary, I'd like you to give the committee the chain of command from the guards to you, all the way up.

Secretary RUMSFELD. I think General Myers brought an indication of it, and we'll show it.

Senator MCCAIN. Thank you. I'd like to know what agencies or private contractors were in charge of interrogations. Did they have authority over the guards? What were their instructions to the guards?

Secretary RUMSFELD. First, with respect to the——

General MYERS. We did not bring it.

Secretary RUMSFELD. Oh, my.

General MYERS. Yeah, oh, my, sir.

Secretary RUMSFELD. It was all prepared.

General MYERS. It was, indeed.

Secretary RUMSFELD. Do you want to walk through it?

Senator MCCAIN. Well, anyway, who was in charge? What agency or private contractor was in charge of the interrogations? Did they have authority over the guards? What were the instructions that they gave to the guards?

General MYERS. I'll walk through the chain of command and——

Senator MCCAIN. No, you can just submit the chain of command for the record, please.

[The information referred to follows:]

Operational Chain of Command (before 19 Nov 03)

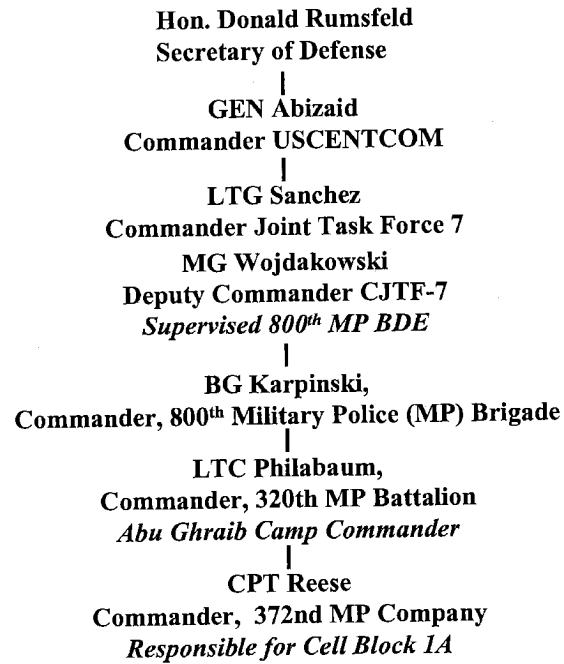

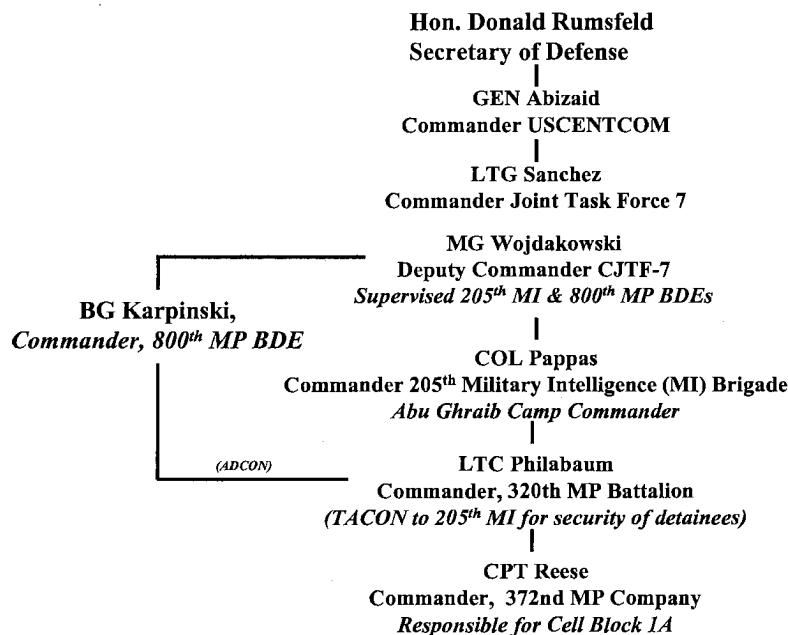
Operational Chain of Command (after 19 Nov 03)

Secretary RUMSFELD. General Smith, do you want to respond?

Senator MCCAIN. No, Secretary Rumsfeld, in all due respect, you have to answer this question, and it could be satisfied with a phone call. This is a pretty simple, straightforward question.

Who was in charge of the interrogations? What agencies and private contractors were in charge of the interrogations? Did they have authority over the guards? What were the instructions to the guards? This goes to the heart of this matter.

Secretary RUMSFELD. It does, indeed. As I understand it, there were two contractor organizations. They supplied interrogators and linguists. I was advised by General Smith that there were maybe a total of 40.

Senator MCCAIN. Now, were they in charge of the interrogations?

General SMITH. Yes, sir. There were 37 interrogators that were—

Senator MCCAIN. I'm asking who was in charge of the interrogations.

General SMITH. They were not in charge. They were interrogators.

Senator MCCAIN. My question is, who was in charge of the interrogations?

General SMITH. The brigade commander for the MI brigade.

Senator MCCAIN. Did he also have authority over the guards?

General SMITH. Sir, he had tactical control over the guards, so he was—

Senator MCCAIN. Mr. Secretary, you can't answer these questions?

Secretary RUMSFELD. I can. I thought the purpose of the question was to try to make sure we got an accurate presentation, and we have the expert here who was in the chain of command.

Senator MCCAIN. I think these are fundamental questions to this issue.

Secretary RUMSFELD. Fine.

Senator MCCAIN. What were the instructions to the guards?

Secretary RUMSFELD. There are two sets of responsibilities, as your question suggests. In one set, you have the people who have the responsibility for managing the detention process. They are not interrogators. The MI people, as General Smith has indicated, were the people who were in charge of the interrogation part of the process. The responsibility, as I have reviewed the matter, shifted over a period of time, and the General is capable of telling you when that responsibility shifted.

[Clarifying information provided by the DOD follows:]

The overall responsibility for the Baghdad Central Confinement Facility (Abu Ghraib) was transferred from the 800th MP Brigade to the 205th MI Brigade by a CJTF-7 Fragmentary Order (FRAGO) on November 18, 2003. In accordance with the order, the units operating at Abu Ghraib came under the tactical control of the 205th MI Brigade for security of detainees and FOB protection. The MP, however, retained responsibility for detention operations.

Senator MCCAIN. What were the instructions to the guards?

Secretary RUMSFELD. That is what the investigation that I have indicated has been undertaken is determining.

Senator MCCAIN. Mr. Secretary, that's a very simple, straightforward question.

Secretary RUMSFELD. As the Chief of Staff of the Army can tell you, the guards are trained to guard people. They are not trained to interrogate, and their instructions are to, in the case of Iraq, adhere to the Geneva Conventions. The Geneva Conventions apply to all of the individuals there, in one way or another. They apply to the POWs, and they're written out, and they're instructed, and the people in the Army train them to that. The people in the CENTCOM have the responsibility of seeing that, in fact, their conduct is consistent with the Geneva Conventions. The criminals in the same detention facility are handled under a different provision of the Geneva Conventions. I believe it's the fourth, and the prior one is the third.

[Clarifying information provided by the DOD follows:]

Detainees who are criminals, persons who attack the force and civilians who are security threats are called "civilian internees" and are protected persons under Geneva Convention IV. Geneva Convention IV applies to all categories of civilian personnel we have detained in Iraq.

Senator MCCAIN. So the guards were instructed to treat the prisoners, under some kind of changing authority, as I understand it, according to the Geneva Conventions.

Secretary RUMSFELD. Absolutely.

Senator MCCAIN. I thank you, Mr. Chairman.

Chairman WARNER. Thank you, Senator.

Senator Kennedy.

Senator KENNEDY. Thank you very much. Thank you, Mr. Chairman.

To the people in the Middle East, and too often today, the symbol of America is not the Statue of Liberty, it's the prisoner standing on a box wearing a dark cape and a dark hood on his head with wires attached to his body, afraid that he's going to be electrocuted. Now, these incidents of torture and abuse have resulted in a catastrophic crisis of credibility for our Nation.

Since the beginning of the war, the International Committee of the Red Cross (ICRC) has provided the Pentagon officials with reports of abuses at this prison, saying that some of them were tantamount to torture. They issued serious complaints during the inspection of the prison in October 2003 and at several other times.

The State Department and the Coalition Provisional Authority (CPA) appealed to you to stop the mistreatment of the military detainees. Secretary Powell raised this issue at Cabinet meetings and elsewhere, pleading with officials from your Department, Mr. Secretary, to see that detainees were properly cared for and treated, and your Department failed to act.

The military leadership put the troops in charge of the prison. They weren't trained to do the job, and they assigned far too few guards to the prison that were required to do the job right. They relied on the civilian contractors to perform military duties, as I understand it, including the interrogation of Iraqi prisoners. As Senator Levin pointed out, the top-level DOD officials directed guards at the prison to set physical and mental conditions for favorable interrogation of the detainees, a decision that directly resulted in the abuses.

The military leadership failed to respond in a systematic way even after it initiated the 35 criminal investigations into alleged mistreatment of detainees in Iraq and Afghanistan, 25 of these investigations involving deaths. I know that Secretary Brownlee referred to this.

In particular, in December 2002, military doctors at the Bagram Air Base in Afghanistan ruled that two Afghan men in U.S. custody died from blunt-force injuries. No one in the military has been held accountable for those homicides.

You and your senior leadership have shown, I believe, a disregard for the protection of the Geneva Conventions in detainee operations. In January 2002, you were asked why you believed the Geneva Conventions do not apply to detainees in Guantanamo. You replied that you did not have the slightest concern about their treatment, in light of what occurred September 11.

According to The New York Times, you have known about the graphic photographic evidence of abuse in the Abu Ghraib prison since mid-January. You told President Bush about these reports of abuse shortly thereafter. Yet, rather than work with Congress to deal with the problem together, you and other top DOD officials have apparently spent the last 3 weeks preparing a public relations plan.

Can you tell us what exactly you did tell the President about these reports of abuse in late January, and what did he say? What did you do about it, and why did month after month after month

have to pass before anything happened? Then we find out that the pictures came out, and the President is, indeed, angry.

Secretary RUMSFELD. First, Senator Kennedy, your statement that other agencies of government were concerned about detainees and the DOD failed to act is simply not correct.

Senator KENNEDY. This wasn't brought to your attention by the State Department?

Secretary RUMSFELD. I'll respond. I did not say that. I said your statement that the DOD—

Senator KENNEDY. It was brought to you then by the State Department. We don't want to parse words. Was this brought to you by the State Department? I mentioned Secretary Powell. The question is whether this was brought to you, and when did you know it? You gave us a laundry list in your presentation about the timeline on it. I'm trying to find out, because it's been published that you were notified about this and advised to do something about it a series of times and nothing was done.

Secretary RUMSFELD. It's not correct to say nothing was done. You're making a set of conclusions that are just simply not accurate. We have had numerous discussions, interagency, on detainees. All in all, there have been some 43,000 people who were captured or detained in Iraq, of whom 31,850 have already been released. That is a big task for the Army to undertake. The actions of the ICRC—you said they came in and indicated concerns about the Abu Ghraib prison. That's correct. The prison officials began the process of making corrections, and General Taguba's report found that a number of those things were already underway, in terms of corrections. When he made his study, a number of additional things and corrections were made. So it seems to me that the ICRC report was helpful, and that the military command, as I understand it, undertook a series of corrections.

Now, with respect to when we were knowledgeable of this, the situation was this. Specialist Darby told the CID that he had information about abuses in the prison. I believe it was on the 13th or 14th of January. By the 15th or 16th, an investigation had been initiated, and CENTCOM's public affairs people went out and told everyone in the world that there were allegations of abuse, and they were being investigated. Again, by mid-March, when some criminal—I don't know the legal term, but some criminal actions were initiated—the CENTCOM's public affairs people went out again and announced that not only were there allegations of abuses, but they listed the types of abuses. This was to the world; everyone knew it. CNN was there asking questions. That is the time frame when General Myers and I were meeting with the President and discussing the reports that we had obviously heard because—they weren't hiding anything. They disclosed it to the world.

Chairman WARNER. Thank you, Senator.

Senator Roberts.

Senator ROBERTS. Thank you, Mr. Chairman. I mean, in no way, to diminish the seriousness of what has occurred here, but it seems very clear to me that the task before Congress is to determine whether or not these abuses are the result of flaws in the system

or if this was a matter, as has been indicated, of individuals who simply broke the rules.

With that in mind, I'd like to know, Mr. Secretary, were any of the abuses that occurred in Iraq encouraged, condoned, or permitted by DOD regulations or policy? Were any local or unit-levels in effect that would have encouraged, condoned, or permitted these abuses?

Secretary RUMSFELD. Certainly not to my knowledge. When one looks at the abuses and the cruelty, the idea that you would have regulations that would permit, condone, or encourage that type of thing is just not comprehensible. General Smith is the deputy at CENTCOM, under General Abizaid, and he is responsible for the management of the guidance and instructions. He can respond if you'd like.

Senator ROBERTS. No, I think you've answered the question, at least to the degree that I want it answered right now. I want to move on.

I do have the privilege of being the chairman of the Senate Intelligence Committee. Three days ago, we had a hearing. We had the MI representatives there. We had the CIA there. They indicated, at that particular time, that they did not know and had no evidence of any direction on the part of intelligence personnel at this prison suggesting that they commit these abuses at the behest of the military interrogators, who asked the MP to "soften up" the detainees to prepare them for the interrogation. This gets back to the opening statement by Senator Levin and the question by Senator McCain.

Let me remind everybody that, as we speak, we have men and women in uniform engaged in combat in Najaf, and basically when we interrogate people, it is to get information from the prisoners, in terms of force protection and in terms of the mission in Iraq, to find out precisely what's going on. It's a very important mission. It was a closed hearing, but I said at the time that I would be stunned—and I've said it to the press—that anybody in MI would condone these kind of activities. This criteria is ingrained, in terms of their training. It's black and white.

So my question to you is—and I think it is going to result in the Fay Report here—is there any truth to the allegations made in the press and by some of the accused MPs that they did commit these abuses at the behest of the military interrogators?

Secretary RUMSFELD. I've read the same allegations and comments that you have. That is what the criminal investigations are looking at, among other things. We will, at an early date, know what the answers are to those questions.

Senator ROBERTS. Can you give me a time frame on when the Fay Report will be completed?

General SMITH. Sir, it should be completed in the next couple of weeks, if he does not ask for an extension. Part of the problem is, that unit has redeployed back to Germany, and so there is traveling back and forth involved.

Senator ROBERTS. That would help answer the question that was asked by Senator McCain as to actually who was "in charge" of that prison. I put the "in charge" in quotes. You had the intelligence, and then you also had the MPs, in terms of the mainte-

nance of the unit, and then it seems to me that there's another command that you mentioned, in terms of the contractors.

I think Senator McCain's question is right on. Who was really in charge? I think you have a tri-part system here. Is that being fixed? Will that be recommended by the Fay Report?

General SMITH. Sir, that's already been fixed with the appointment of Major General Geoff Miller as the——

Senator ROBERTS. He's the person that straightened out Guantanamo Bay down in Cuba.

General SMITH. Sir, he is there doing that right now. He has been there since the middle of April.

Senator ROBERTS. I thank you, Mr. Chairman.

Chairman WARNER. Thank you very much.

Senator Byrd.

Senator BYRD. Mr. Chairman, thank you for calling this timely and important hearing. I apologize for my voice. I've been struggling with a bout of laryngitis.

I share your outrage over the atrocities that have emerged from the Abu Ghraib prison. I believe Congress has the responsibility to demand a public accounting and a public explanation from the leadership of the DOD. I'm sure this is only the beginning of a long and painful process, but I am glad that you've taken the first steps to begin a necessary public examination of the massive policy failure that led to this catastrophe.

Among the many aspects of this situation that are so troubling to me is why the President and his advisors are only now publicly condemning the prisoner abuses in Iraq, when apparently the DOD has known about them for months. I do not recall hearing a peep out of either of you, Secretary Rumsfeld or General Myers, about this before CBS broke the silence.

Why did it take the televised broadcast of graphic photos of prisoner abuse, a broadcast General Myers has acknowledged he tried to suppress, to galvanize the leadership of the DOD to express its outrage over the situation?

Why was a report that described sadistic, blatant, and wanton criminal abuses by American soldiers left to languish on a shelf in the Pentagon unread by the top leadership until the media revealed it to the world? Why wasn't Congress apprised of the findings of this report from the DOD instead of from CBS News?

Mr. Secretary, it was President Truman who was said to have displayed the famous sign on his desk, "The buck stops here." I served with President Truman. He was an honorable man. He did not shirk his responsibility.

I see a very different pattern in this administration. I see arrogance and a disdain for Congress. I see misplaced bravado and an unwillingness to admit mistakes. I see finger-pointing and excuses.

Given the catastrophic impact that this scandal has had on the world community, how can the United States ever repair its credibility? How are we supposed to convince not only the Iraqi people, but also the rest of the world, that America is, indeed, a liberator and not a conqueror, not an arrogant power? Is a presidential apology to the King of Jordan sufficient? I ask you that question.

Secretary RUMSFELD. Senator, the facts are somewhat different than that. The story was broken by CENTCOM, by the DOD, in

Baghdad. General Kimmitt stood up, in January, and announced that there were allegations of abuses and that they were being investigated. He then briefed reporters. I think it was March 20. There's a timeline up here. By March 20, he went back out again and said that these had been filed.

The idea that this was a story that was broken by the media is simply not the fact. This was presented by CENTCOM to the world so that they would be aware of the fact that these had been filed. What was not known is that a classified report with photographs would be given to the press before it arrived in the Pentagon.

Senator BYRD. Mr. Secretary, we'll put my timeline in the record and compare it with yours.

[The information referred to follows:]

SECTION: MAIN NEWS; Foreign Desk; Part A; Pg. 1

LENGTH: 1767 words

HEADLINE: **Bush Scolds Rumsfeld** on Abuse Inquiry;

The Iraq scandal caught the president off guard, an official says. The Pentagon maintains it made the prison charges known to the White House.

BYLINE: Edwin Chen, John Hendren and Janet Hook, Times Staff Writers

DATELINE: WASHINGTON

BODY:

A clash erupted Wednesday between the White House and the Pentagon over the handling of the Iraq prison abuse investigation, with President Bush telling Defense Secretary Donald H. Rumsfeld that he felt personally blindsided by the scandal and should have been more fully informed about its severity.

Bush rebuked Rumsfeld during an Oval Office meeting, a senior administration official said Wednesday evening. Bush told Rumsfeld that the White House should have been informed about the photographs documenting some of the abuses, which began appearing in the news media late last week, the senior official said.

"The president wasn't satisfied when he saw those pictures on TV," the official said, referring to photographs of Iraqi prisoners stripped naked and being abused. "And he made that clear to Secretary Rumsfeld. They should have been brought to his attention, and he shouldn't have had to learn of them through the media."

The official said Rumsfeld agreed with Bush that the manner in which the information reached the president was "not satisfactory."

However, Pentagon officials contended that Rumsfeld and defense officials moved swiftly to make the seriousness of the charges known within the administration and at news briefings. They said a senior Pentagon official confirmed to a reporter in January the possibility of graphic photographs.

"This was attacked very aggressively," said Pentagon spokesman Lawrence Di Rita. "The White House notification was a symptom that everyone knew this was important. I think there was a good understanding that this was a big deal."

The divergent views of how the Pentagon handled the crisis were unusual in an administration known for discouraging the appearance of dissent and came as Congress moved forward on investigations of the abuse at the U.S.-run Abu Ghraib prison near Baghdad. Some lawmakers have suggested that Rumsfeld's future may be in doubt.

"If it goes all the way to Rumsfeld, then he should resign," said Sen. Joseph R. Biden Jr. (D-Del.). "Who is in charge?"

Even some congressional Republicans were angry with the Pentagon for failing to prepare them for the abuse revelations. Gathering GOP frustration raises the stakes for Rumsfeld, who is scheduled to testify Friday before the Senate Armed Services Committee.

A Rumsfeld resignation would have an enormous political downside, a senior House Republican aide said. It would be viewed as an admission of failure in the middle of a war and an embarrassing concession to Democratic critics during Bush's reelection campaign, the aide said.

A senior aide to the Senate Republican leadership said he did not think that animosity toward the Pentagon had reached the point that Republicans would call for Rumsfeld's resignation, but that there was a clear sense that "some heads should roll at the Pentagon."

Senate Republicans were angry not only that the Pentagon withheld information about the prison problem for months, but that Rumsfeld did not mention it when he appeared at a closed-door briefing of the Senate on the day that CBS first aired the photographs documenting the abusive treatment of Iraqi prisoners.

Some saw the Pentagon's handling of the matter as in keeping with what lawmakers viewed as a general disdain for sharing information with Congress and consulting with it on military matters.

"Hubris is a dangerous disease," said one senior member of the Senate Armed Services Committee.

The president reprimanded Rumsfeld at a White House meeting that had been previously scheduled to discuss a request for \$25 billion in new funding for operations in Iraq and Afghanistan, the senior administration official said.

"Secretary Rumsfeld was not summoned exclusively on this [prisoner abuse] issue. But it was the top issue when they met," the official said.

The White House and Pentagon differed not on factual accounts but over questions of whether the severity of the abuses had been made clear and whether the potential for worldwide uproar over the publication of the photographs had been anticipated and addressed.

The abuses took place in Iraq between October and December, and the commander of U.S. forces in Iraq, Lt. Gen. Ricardo Sanchez, appointed Maj. Gen. Antonio M. Taguba to undertake an investigation of problems Jan. 31.

Taguba said he and his investigators looked at photographs but did not include them in addenda to his report. At the time, a criminal investigation by the Army Criminal Investigation Command already had been initiated, Taguba said.

Rumsfeld said Wednesday that Pentagon officials first learned of the abuses Jan. 13. A senior defense official said Rumsfeld was told of them a day or so later.

About that time, in January, officials said, Rumsfeld mentioned the prisoner abuse investigation to Bush at a regularly scheduled White House meeting.

At that session, White House Press Secretary Scott McClellan said Wednesday, Bush was satisfied after the defense secretary gave him "a general sense" of the allegations and assured him that "there was an investigation underway."

McClellan said that neither Bush nor White House Chief of Staff Andrew H. Card Jr. could remember the date on which Rumsfeld told the president of the allegations and the ensuing investigation. Di Rita also was unable to specify the date.

On Jan. 16, the U.S. Central Command in Baghdad announced in a five-sentence news release that an inquiry had begun into "reported" incidents of detainee abuse. Rumsfeld this week said the U.S. had "issued a press release to the world."

The Jan. 16 release did not name the prison or give any details of the incidents, saying only that the U.S.-led Coalition Provisional Authority was "committed to treating all persons under its control with dignity, respect and humanity."

Bush evidently was unaware of the details of the unfolding investigation and apparently did not know that Air Force Gen. Richard B. Myers, chairman of the Joint Chiefs of Staff, asked CBS last month to delay broadcast of its "60 Minutes II" segment on the abuses.

"The precise nature of what occurred only came to light more recently," McClellan said, referring to Bush's statement Wednesday during interviews with two Arabic-language TV channels that he had learned of the details from media reports.

Rumsfeld said this week that he, too, had not seen the disturbing photographs before they were broadcast last week. When he had asked about the photographs, Rumsfeld said, he was told by Pentagon officials, "We didn't have copies."

Several experts and presidential scholars said they were surprised that the White House and senior Bush advisors, mostly notably Rumsfeld, did not seek to preempt the impact of the CBS broadcast by getting the information out on their own terms.

"It's extremely surprising that, once the word was passed to Rumsfeld, he didn't tell the president and his team so they could prepare to defend themselves," said former White House advisor David Gergen, who has served presidents of both parties.

"An aggressive White House would have preempted CBS and gotten the stuff out and say, 'By God, we're going to clean it up.'" said Gergen, who teaches at Harvard University. "Instead, it looks as if they've been sitting on the pictures and the whole story. They've made it much worse by sitting on this."

A senior Pentagon official acknowledged that some things could have been "done better." The official said that before the photographs were broadcast, Pentagon officials could have made public statements about the case.

*

Key dates in the Iraq prison abuse scandal:

* June 30, 2003: Army Reserve Brig. Gen. Janis Karpinski named commander of all military prisons in Iraq.

* Aug. 31-Sept. 9: A team of counter-terrorism experts investigating prisoner interrogations in Iraq concludes that although the prisons should provide a "safe, secure and humane environment that supports the expeditious collection of intelligence, ... it is essential that the guard force be actively engaged in setting the conditions for successful exploitation of the internees."

* October: The 372nd Military Police Company ordered to guard Abu Ghraib prison near Baghdad.

* Oct. 13-Nov. 6: A team of military police and legal and medical experts reviews the prison system in Iraq; it concludes that there are possible manpower, training and human rights problems that should be addressed immediately.

* Jan. 13, 2004: Member of the 800th Military Police Brigade tells superiors about prison abuses, and Pentagon officials are informed. Defense Secretary Donald H. Rumsfeld is told a day or so later. Shortly afterward, Rumsfeld tells Bush.

* Jan. 14: U.S. commander in Iraq, Army Lt. Gen. Ricardo Sanchez, opens criminal investigation of abuses.

* Jan. 16: U.S. Central Command announces that an investigation of prison abuses is underway.

* Jan. 17: Sanchez formally advises Karpinski that there are serious deficiencies in her command and that the performance reflects a lack of leadership. Karpinski is later suspended from duty.

* Jan. 19: Sanchez asks for a high-level review of prison procedures.

* Jan. 24: Lt. Gen. David McKiernan, U.S. ground forces commander in Iraq, is directed to conduct the review.

* Jan. 31: Maj. Gen. Antonio M. Taguba is named chief investigator on the review.

* Feb. 2: Taguba and his team visit Abu Ghraib.

* March 3: Taguba's preliminary findings are presented to McKiernan; they point to members of the 372nd Military Police Company and intelligence operatives as the abusers.

* March 13: The Army's Criminal Investigation Division charges six soldiers with counts ranging from conspiracy to indecent acts.

* April 6: McKiernan approves some report recommendations, including letters of reprimand for six MPs and noncommissioned officers; two are relieved of duties.

* April 28: "60 Minutes II" shows photographs of prisoners forced to engage in simulated sex acts.

* May 3: Senate Armed Services Committee Chairman John W. Warner (R-Va.) asks Pentagon officials to testify before his committee the next day.

* May 4: Defense Secretary Donald H. Rumsfeld says those responsible will be brought to justice and

widens investigations of prisons outside Iraq and Afghanistan. National security advisor Condoleezza Rice tells the Arab world that the abuses will be investigated and the perpetrators punished. Army officials give Senate committee a private briefing.

* May 5: President Bush appears on two Arab television channels, saying those responsible for the abuses will be brought to justice. Rumsfeld agrees to testify before the Senate committee in open session Friday.

Sources: Associated Press, Department of Defense, Agence France-Presse

GRAPHIC: PHOTO: FUTURE IN DOUBT? Resignation rumors swirl around Donald H. Rumsfeld.
PHOTOGRAPHER: Reuters

LOAD-DATE: May 6, 2004

Senator BYRD. My question is, is a presidential apology to the King of Jordan sufficient?

Secretary RUMSFELD. Senator, I guess that's for the President and Congress and others to decide. There have been many apologies. There have been apologies by every person at this table today. Any suggestion that there is not a full, deep awareness of what has happened and the damage it has done, I think, would be a misunderstanding.

The report that we're talking about is sitting right there on the floor. It is—I don't know—what, 2-foot high?

Senator BYRD. Did you read it?

Secretary RUMSFELD. I read the executive summary, which is 50 to 75 pages, and I looked at some of the annexes and appendices and references. I have been briefed on it in full, as have the people at this table, and you can be certain of that.

Senator BYRD. The ICRC claims that it made reports of prisoner abuse in Iraq throughout 2003. I understand that those reports are confidential, by mutual agreement. Secretary Rumsfeld, how do we know that there isn't a broader problem here? We have heard reports of prisoner abuse from more than just the Abu Ghraib prison. Will you ask the ICRC to waive its confidentiality agreement on those reports, and make public all pertinent reports on U.S. military-run prison facilities, including those in Iraq, Afghanistan, Guantanamo, and elsewhere?

Secretary RUMSFELD. We will certainly be happy to provide the committee with all the reports that we have. I think the issue of the ICRC allowing one of their reports to be made public is an issue for them, because they worry that they will not be told the truth when they go into countries where there are dictatorships and where people are systematically punished and tortured, and people do not want to talk to them if the ICRC gets a reputation for making their report public. So we will be happy to give you our reports, on a confidential basis that is respectful of the ICRC's stipulations.

Chairman WARNER. Thank you very much, Senator.

Senator BYRD. May I just follow with a postscript?

Chairman WARNER. All right, Senator.

Senator BYRD. With all due respect to you, the matter is far deeper than that. The American people need to know what's in those reports. When the ICRC supplies the DOD with those reports, Congress should have that material.

Secretary RUMSFELD. We'd be happy to give it to you.

Senator BYRD. Very well, thank you.

Chairman WARNER. Thank you.

Senator Allard.

Senator ALLARD. Mr. Chairman, first of all I want to thank you for holding this committee hearing. I know there was some discussion about the format and everything, but I think it's the right thing to do to have this as an open hearing. I want to also thank the panel for agreeing to come here and testify before us in an open hearing. That's the strength of America, that we're willing to come out in a public manner and talk about our strengths and weaknesses, and lay out how we're going to deal with those. As somebody who has participated in this, I think that we are sending a good message to the world that we are open; that we are not a perfect people, but we do our best. I just wanted to make that statement before I asked any questions.

The thing that I heard in your testimony, Mr. Secretary—and I think it needs to be elaborated on—is this issue of command influence. I know that as the facts become evident, that prosecutors of misconduct in the military have a real concern about command influence. I would like you to elaborate more on that, or maybe some other panel members might elaborate on that, and how that might affect a case for prosecution. You mentioned you had six courts-martial, I believe, and I wondered if you would share that with the committee.

Secretary RUMSFELD. We are continuously advised by lawyers, counsels, that there are two issues that create a tension. One is the importance of having integrity in the criminal prosecution process, and that people in the chain of command that conceivably, over time, would be called upon to make a judgment about the decisions at the lower levels do not inject themselves into that process early or in a way that would lead people to believe that their comments were influencing the outcome of some of those criminal decisions or other decisions. Therefore, people in the chain are in a difficult position. To the extent we have a discussion like this about what's taken place, we can be certain that the defense counsels for these people who are being accused, and are going to be criminally prosecuted, will say that these hearings and this discussion had an influence on the case. We don't want to have that be the case, and that's why we're being careful in what we say.

The other side of the coin is, we don't want someone's rights to be infringed upon, someone who is a defendant and may be innocent. A process could lead to a situation where their rights would not be fully protected. So we do have to be careful.

Senator ALLARD. If there are six courts-martial now, do you anticipate there will be more courts-martial? Have any of those in command been indicted?

Secretary RUMSFELD. I checked, and last year we had something like 18,000 criminal investigations opened, and we ended up with 3,000 courts-martial. So, at any given time, with a large organization like the DOD, there is always something happening.

There is no way in the world I could anticipate. But the investigations are open, the investigators are determined, and, to the extent they find information that leads them to believe that a court-

martial is indicated, or non-judicial punishment of other types, they certainly will do so. They understand the gravity of this.

Senator ALLARD. I want to follow up on the ICRC report. Were they given full access? What main issues did that report raise?

Secretary RUMSFELD. I have the report somewhere here, and I'd be happy to let you see it. I'm reluctant to start discussing it, but I can say what I already said, that they found a number of things that they were concerned about, as they always do. It's helpful, I must say. The people then began to read it, agree or disagree, and make the changes. When General Taguba came in and made his report, he indicated that a number of the issues that had been raised last year by the ICRC had, in fact, been corrected by the command structure between the time that they were observed by the ICRC and the time that General Taguba's team arrived on the scene.

Senator ALLARD. Mr. Chairman, my time is expired. I do have a written statement for the record.

[The prepared statement of Senator Allard follows:]

PREPARED STATEMENT BY SENATOR WAYNE ALLARD

Thank you, Mr. Chairman. Let me first join you in welcoming our witnesses this morning to discuss the troubling issue of prisoner abuse involving our Armed Forces.

I am deeply saddened and distressed over these allegations. When we commit our military to fight our country's wars, we fully expect each and every American soldier to serve as the model soldier-statesman, a standard bearer for people everywhere. Our American forces are to be feared for their unmatched effectiveness and valor in combat. More importantly, they are to be respected and valued for their humanitarian and compassionate conduct when carrying out their duties.

We are at a delicate phase now, introducing to the Afghans and Iraqis the promises of a democracy and the better times ahead. A major part of our difficulty is the fact that these people simply do not yet know what democracy holds for them—they have yet to experience the freedoms and justice that Americans take for granted.

Today, we rely on our Armed Forces to set this stage, to help these emerging democracies take root. What is so disturbing is that these allegations erode, to the core, the basic principles of liberty we so desperately need to instill and uphold across this region.

Based on my preliminary readings, Mr. Chairman, I don't believe we will uncover systemic problems in our military of wanton disregard for either the rule of law or general human rights. Rather, I believe the committee will see, in painful detail, a case study of the extraordinary damage that can occur when we experience such a disastrous breakdown in military leadership and discipline. It is of small consolation that there were many solid, upstanding soldiers in the middle of this leadership void that maintained their military bearing, sought command attention for these violations, and carried-on in accordance with the high professional standards we all expect.

I find it extremely unfortunate that the activities of so few are now overshadowing the extraordinary accomplishments of so many. I visited both Afghanistan and Iraq earlier this year, and got to see firsthand many of our 130,000 uniformed service men and women undertaking heroic public works projects. General Smith's Central Command is engaged in building mosques, schools, hospitals, roadways, water, and sewage facilities, and other critical infrastructure desperately needed across the region. Now, however, we have a small minority of apparently misled, misfit commanders and soldiers casting a negative light over what should be, and what I hope will ultimately be, a proud accomplishment for our forces.

Mr. Secretary and Chairman Myers, I understand the scope of your job and responsibilities are enormous. I believe that comprehensive remedies to this situation need to be among your top priorities. Let's get out in the open the relevant information and answers we need to close this issue soonest. Let's get the solutions and preventive measures identified and in place soonest. Let's get the few soldiers and commanders—those that let us all down—before the appropriate judicial process and punish the guilty accordingly.

Chairman WARNER. Thank you very much.

Senator Lieberman.

Senator LIEBERMAN. Thank you, Mr. Chairman.

Mr. Secretary, the behavior by Americans at the prison in Iraq is, as we all acknowledge, immoral, intolerable, and un-American. It deserves the apology that you have given today, as well as the apologies that have been given by others in high positions in our Government and our military.

I cannot help but say, however, that those who were responsible for killing 3,000 Americans on September 11, 2001, never apologized. Those who have killed hundreds of Americans in uniform in Iraq, working to liberate Iraq and protect our security, have never apologized. Those who murdered and burned and humiliated four Americans in Fallujah a while ago never gave an apology to anybody. Wrongs occurred here by the people in those pictures and perhaps by people up the chain of command.

But Americans are different. That's why we're outraged by this. That's why the apologies were due. That's why I hope, as we go about this investigation, we do it in a way that does not dishonor the hundreds of thousands of Americans in uniform who are a lot more like Pat Tillman and Americans that are not known, like Army National Guard Sergeant Felix del Greco, of Simsbury, Connecticut, who was killed in action a few weeks ago. We shall not dishonor their service or discredit the cause that brought us to send them to Iraq, because it remains one that is just and necessary.

We have to get to the whole truth here, and nothing but the truth. We can't be defensive. We have to be aggressive about it. As Senator McCain said, we have to do it quickly so that we and you and, most of all, our soldiers can get back to fighting and winning the war on terrorism with determination.

As far as I'm concerned, we do have to know how this happened, and we have to know it so we can stop it from happening ever again. You've said that the behavior of those soldiers was fundamentally un-American. I agree with you. This goes way back to the first American declaration, the Declaration of Independence, where we said that every human being has those rights as an endowment of our Creator. That even goes to human beings who have been apprehended by our military, as they have been in Iraq, because they are suspected of being part of the terrorists, of the jihadists, of the foreign fighters, of the Saddam loyalists, who are killing Americans and Iraqis every day.

We know that people are flawed, and that's why we believe in the rule of law, to try to make us better and punish those who fall below appropriate humane standards.

In that regard, it seems to me when it comes to the treatment of prisoners and detainees in conditions of combat, the Geneva Conventions, adopted by the United States as the law of the land—and that have been implemented by U.S. Army Regulation 190–8. You made some controversial statements early on, after Afghanistan, that said the Geneva Conventions were “not relevant here,” that, “by and large”—and I'm quoting generally—“American military interrogators or prison guards would try to carry out the rights of prisoners and detainees according to the Geneva Conven-

tions.” But I want to ask you today, as you look back to that, do you think you were right? Did anything replace the rules of the Geneva Conventions in Army Regulation 190–8? If not, why not?

Secretary RUMSFELD. Senator, the President of the United States made a determination in early 2002 that the Geneva Conventions’ provisions did not apply to our conflict with al Qaeda, although he concluded that Geneva Conventions did apply to the conflict with the Taliban. That was a decision by the President. He determined that Taliban detainees did not qualify as POWs under the third Geneva Convention criteria for POWs. He also made clear that it was, and will continue to be, America’s policy to treat detainees humanely and in a manner that was consistent with the Geneva Conventions. So the people were treated consistent to the Geneva Conventions, but he made a distinction with respect to al Qaeda.

Senator LIEBERMAN. Are these detainees, do you assume, members of al Qaeda? That is, the thousands that have been held in Iraq? Or are they in another status?

Secretary RUMSFELD. Oh, no, the President announced from the outset that everyone in Iraq who was a military person and was detained is a POW, and, therefore, the Geneva Conventions apply. Second, the decision was made that the civilians or criminal elements that are detainees are also treated subject to the Geneva Conventions, although it’s a different element of it. I think it’s the fourth instead of the third.

Senator LIEBERMAN. I appreciate that clarification, because I was not aware of that. Then you would say that all those held in prison, including those who were abused here, had the rights of POWs under the Geneva Conventions.

General MYERS. Absolutely.

[Clarifying information from the DOD follows:]

All detainees held in Iraq are protected under the Geneva Conventions. Enemy POWs are covered under Geneva Convention III. Civilians are protected under Geneva Convention IV. Those pictured in the photographs from Abu Ghraib are believed to be civilians.

Senator LIEBERMAN. Therefore, the fault clearly was that those we’ve seen, and hopefully not others, were either not properly trained, properly disciplined, or, in any case, not observing the law of the United States of America with regard to the rights of POWs.

General MYERS. If I may, I think that’s exactly right. It’s aberrant behavior. The Taguba Report, if you recall, looked at four installations where the 800th MP Brigade had operations. They found abuse in only one, and that’s Abu Ghraib. They found abuse in one.

Senator LIEBERMAN. My time’s up. Thank you.

Chairman WARNER. Thank you very much.

Senator Sessions.

Senator SESSIONS. Thank you, Mr. Chairman.

These are, indeed, actions that go against the very core values of America. I want to say, however, that I believe the military responded properly immediately. I want to join with Senator Lieberman’s courageous and strong comments about how we do not need to dishonor the soldiers out there this very day, at risk of their lives, withholding firing weapons, being in hostile situations, taking chances with their own lives to protect the people of Iraq.

Yes, this is a serious problem, and we need to do something about it. Those who dishonored those soldiers need to be punished. But I feel very strongly that the military deserves a lot of credit here, and I want to go over this chart, General Myers, that you have there.

First, I want to say to Secretary Rumsfeld and all of you there, thank you for your leadership. Yes, you have some complainers in Congress, but we voted to send our soldiers to this effort. Nobody else authorized you to go. We voted to support it. I would also note that the terrorists aren't happy with you, either. I saw they put a \$15 million bounty on your head, along with General Kimmitt and General Sanchez. I thank you for that service.

General MYERS. Senator Sessions, you want me to go through the—

Senator SESSIONS. I would just like to ask you a little bit about it, because our time is short.

General MYERS. Right.

Senator SESSIONS. As I see it, back in August of last year you appointed an assessment team. Is that right? Long before this occurred.

General MYERS. Right. As I said in my opening statement, I think we ought to have a lot of confidence in our military leadership handling the detention situation in Iraq. It was on August 11 that General Sanchez was worried about detention and interrogation operations, and that resulted in General Miller going over there and submitting a report.

We pushed General Miller on them in August 2003 because he was so successful in Guantanamo—to look at our detention operations to make sure that we're doing it right, and also that it's well connected, that the intelligence is getting to the analysts and so forth, so we can win this.

Senator SESSIONS. Now, was this in response to any incident or was it on your own initiative?

General MYERS. That was our own initiative. That was a discussion between the Secretary and myself and our staffs.

You can see from the chart when the abuse took place. We were told of the abuse on January 13, 2004. The next day, the Army police, the CID, went on that particular case. We talked about the press.

Senator SESSIONS. No, let's slow down. On January 14, you started a criminal investigation based on the complaint of one soldier.

General MYERS. They did.

Senator SESSIONS. On January 16, Major General Kimmitt briefed the world about the investigation commencing. Is that correct?

General MYERS. Right, and he talked about abuse. As I remember it, he said there may be pictures involved with this abuse, as well. Then it was 3 days later where General Sanchez—based on that criminal investigation he had started—asked for an investigating officer who turned out to be General Taguba. The general was asked to look at this MP brigade that was responsible for detention operations in Abu Ghraib and those three other locations.

I know we need to do things quickly with full disclosure and everything. But this 15–6 Report, the Taguba Report, can result in

administrative actions such as relief from command and other administrative admonishments to military personnel. So it has to be very thorough. That's why you'll see it was requested on January 16. It was not approved by General Sanchez until May 1. As you go through the various chains, the people that are implicated in wrongdoing have a chance to look at the report and rebut the report. That's part of this process that I think we owe it to our troops to uphold.

Senator SESSIONS. But, General Myers, on January 18, according to that chart, the 320th MP Battalion had leadership suspended. Is that correct?

General MYERS. That's correct.

Senator SESSIONS. That's a pretty dramatic action to take, is it not?

General MYERS. It is. But the first look by the Army CID, I think, gave them indications that things were not right.

Senator SESSIONS. Now, this wasn't by any pressure from the media or anyone else; this was the military's own decision that their high standards had been violated, and that strong actions should be taken.

General MYERS. This was General Abizaid, General Sanchez, and their folks, absolutely.

Senator SESSIONS. I know some on this committee have complained when you took strong action against the brigade commander publicly, the soldier who fired a weapon as part of an interrogation effort. He had a fine record. You took strong action on that case, and some of us in Congress complained you were too tough.

General MYERS. The standards are the standards, Senator.

Chairman WARNER. Thank you very much, Senator.

Senator SESSIONS. We thank you for your service, all of you.

Chairman WARNER. Senator Reed?

Senator REED. Thank you, Mr. Chairman.

Let me begin by stating the obvious. For the next 50 years, in the Islamic world and many other parts of the world, the image of the United States will be that of an American dragging a prostrate, naked Iraqi across the floor on a leash. This is unfair to the honor and the courage to our soldiers, but, unfortunately, I think it's become a fact. This is disastrous.

Mr. Secretary, let me follow up on your proposed commission. As I understand your comments, this commission, or this group of people, will not have the authority to call witnesses to obtain material independent of your investigation. They will simply review what you're doing?

Secretary RUMSFELD. We will be happy to give you a copy of the draft charge to the individuals. They will have, I can assure you, the absolute full cooperation of the DOD.

[The information referred to follows:]

SECRETARY OF DEFENSE
1000 DEFENSE PENTAGON
WASHINGTON, DC 20301-1000

May 12, 2004

MEMORANDUM FOR THE HONORABLE JAMES R. SCHLEGINGER,
CHAIRMAN

THE HONORABLE HAROLD BROWN
THE HONORABLE TILLIE FOWLER
GENERAL CHARLES A. HORNER, USAF (RET.)

SUBJECT: Independent Panel to Review DoD Detention Operations

Various organizations of the Department of Defense have investigated, or will investigate, various aspects of allegations of abuse at DoD Detention Facilities and other matters related to detention operations. Thus far these inquiries include the following:

- Criminal investigations into individual allegations
- Army Provost Marshal General assessment of detention and corrections operations in Iraq
- Joint Task Force Guantanamo assistance visit to Iraq to assess intelligence operations
- Administrative Investigation under AR 15-6 regarding Abu Ghraib operations

- Army Inspector General assessment of doctrine and training for detention operations
- Commander, Joint Task Force-7 review of activities of military intelligence personnel at Abu Ghraib
- Army Reserve Command Inspector General assessment of training of Reserve units regarding military intelligence and military police
- Naval Inspector General review of detention procedures at Guantanamo Bay, Cuba, and the Naval Consolidated Brig, Charleston, South Carolina

I have been or will have been briefed on the results of these inquiries and the corrective actions taken by responsible officials within the Department.

It would be helpful to me to have your independent, professional advice on the issues that you consider most pertinent related to the various allegations, based on your review of completed and pending investigative reports and other materials and information. I am especially interested in your views on the cause of the problems and what should be done to fix them. Issues such as force structure, training of regular and reserve personnel, use of contractors, organization, detention policy and procedures, interrogation policy and procedures, the relationship between detention and interrogation, compliance with the Geneva Conventions, relationship with the International Committee of the Red Cross, command relationships, and operational practices may be contributing factors you might wish to review. Issues of personal accountability will be resolved through established military justice and administrative procedures, although any information you may develop will be welcome.

I would like your independent advice orally and in writing, preferably within 45 days after you begin your review. DoD personnel will collect information for your review and assist you as you deem appropriate. You are to have access to all relevant DoD investigations and other DoD information unless prohibited by law. Reviewing all written material relevant to these issues may be sufficient to allow you to provide your advice. Should you believe it necessary to travel or conduct interviews, the Director of Administration and Management will make appropriate arrangements.

I intend to provide your report to the Committees on Armed Services, the Secretaries of the Military Departments, the Chairman of the Joint Chiefs of Staff, the Commanders of the Combatant Commands, the Directors of the Defense Agencies and others as appropriate. If your report contains classified information, please also provide an unclassified version suitable for public release.

By copy of this memorandum, I request the Director of Administration and Management to secure the necessary technical, administrative and legal support for your review from the Department of Defense Components. I appoint you as full-time Employees of this Department without pay under 10 U.S.C. Article 1583. I request all Department of Defense personnel to cooperate fully with your review and to make available all relevant documents and information at your request.

Signed //Donald H. Rumsfeld//

Senator REED. Will they have the opportunity to call individuals to testify?

Secretary RUMSFELD. Indeed.

Senator REED. Thank you.

Secretary RUMSFELD. I wouldn't use the word "testify," but certainly they can call individuals.

Senator REED. Mr. Secretary, the Taguba Report indicated the principle focus of Major General Miller's team was on the strategic interrogation of detainees in Iraq. Among its conclusions in its executive summary was that CJTF-7 did not have authorities and procedures in place to effect a unified strategy to detain, interrogate, and report information from detainees/internees in Iraq. The executive summary also stated that detention operations must act as an enabler for interrogation.

Major General Miller was involved with Guantanamo, a DOD operation in another theater. He was sent to Iraq. I don't think major generals in the United States Army make up policies about strategic interrogation of detainees unless they've coordinated and communicated to the higher headquarters. Did you ever see, approve, or encourage this policy of enabling for interrogation? Did Secretary Cambone ever see, approve, or encourage this policy at either facility?

Secretary RUMSFELD. I don't recall that a policy came to me for approval. I think that what we have known since September 11 is that we had three issues with respect to people that were detained. One issue was to get them off the street so they can't kill again—more innocent men, women, and children. A second was the question of criminal prosecution for wrongdoing. The third was to interrogate and see if additional information could be found that could prevent future terrorist acts against our country or our forces or our friends and allies. So all of those things have been parts of it since the beginning. They're different functions, as you point out.

Senator REED. Is that Secretary Cambone's view, too? Did he either see, approve, or encourage—he's behind you. Can he respond?

Secretary RUMSFELD. Sure he can respond.

Mr. CAMBONE. Sir, the original—

Chairman WARNER. Would you identify yourself for the record, please?

Mr. CAMBONE. Yes, sir. My name is Steve Cambone. I'm the Under Secretary of Defense for Intelligence, Senator.

The original effort by Major General Miller was done with respect to Guantanamo, and had to do with, in fact, whether or not we had the proper arrangements in the facilities in order to be able to gain the kind of intelligence we were looking from those prisoners in Guantanamo. We had then, in Iraq, a large body of people who had been captured on the battlefield that we had to gain intelligence from for force-protection purposes, and he was asked to go over, at my encouragement, to take a look at the situation as it existed there. He made his recommendations.

Senator REED. Were the recommendations made to you, Mr. Secretary? Did you approve them?

Mr. CAMBONE. To me directly? No. They were made to the command.

Senator REED. But you were aware of the recommendations about enabling interrogation?

Mr. CAMBONE. I was aware of those recommendations. I was aware that he made the recommendation that we get a better coordination between those who are being held and those who were being interrogated.

Senator REED. Mr. Secretary, were you aware that a specific recommendation was to use MPs to enable an interrogation process?

Mr. CAMBONE. In that precise language, no; but I knew that we were trying to get to the point where we were assuring that when they were in the general population, those that were under confinement were not undermining the interrogation process.

Senator REED. So this was Major General Miller's own policy?

Mr. CAMBONE. No, sir, it was not a policy; it was a recommendation that he made to the command.

Senator REED. So General Sanchez adopted this policy, making it a policy of the United States Army and the DOD, without consultation with you on any specific—

Mr. CAMBONE. Sir, I don't think that's a proper rendering of it.

Senator REED. I don't know what the proper rendering is, but that seems to be at the core of this issue. Were you encouraging a policy that had MP officers enabling interrogations, which created the situation where these—

Mr. CAMBONE. No, sir.

Secretary RUMSFELD. May I comment? I think it is probably best put this way. They are different responsibilities, detaining and interrogating. However, they do need to be looked at together. They found, in Guantanamo, that how they are detained, in terms of the rhythm of their lives, can affect the interrogation process. So the linkage between the two is desirable if, in fact, you're concerned about finding more information that can prevent additional terrorist acts or, in the case of Iraq, the killing of our forces. So it's important that there be a linkage, a relationship. The way it can be put is that it has a bad connotation. Goodness knows, that's not desirable or a policy that General Miller would have recommended.

On the other hand, it can—

Senator REED. The policy seems to be to link—

Chairman WARNER. Senator, I have to ask if you would require the witnesses to provide further responses for the record.

Senator REED. Mr. Chairman, I will certainly ask for additional responses.

Chairman WARNER. Thank you very much.

Senator REED. Thank you.

Chairman WARNER. Senator Collins.

Senator COLLINS. Mr. Secretary, the vast majority of American troops performed their duties with compassion, fairness, and courage. This abuse makes the tasks which they've been assigned far more difficult and far more dangerous, and that troubles me greatly. Worst of all, our Nation, a Nation that, to a degree unprecedented in human history, has sacrificed its blood and treasure to secure liberty and human rights around the world, now must try to convince the world that the horrific images on their TV screens and front pages are not the real America, that what they see is not who we are.

That is why, Mr. Secretary, I'm so troubled by the Pentagon's failure to come forward to fully disclose this appalling abuse, to express outrage and concern, and to outline swift, tough, corrective actions. I believe that had you done that, it would have mitigated somewhat how this abuse has been perceived around the world, particularly in the Muslim communities. I'm not talking about

issuing a press release from Baghdad. I'm talking about you personally coming forward and telling the world what you knew about this abuse.

In retrospect, do you believe that you erred in not coming forward, not just to the President and Congress—you've made very clear today that you regret not doing that—but to the world community? Would it have made a difference if it had been the Pentagon itself that had disclosed the full extent of this abuse, whatever you knew, and what actions you were going to take?

Secretary RUMSFELD. I think in my statement I responded in full to your question. I would characterize what was done in CENTCOM, by way of swift corrective action, as being just that—swift corrective action.

Second, I don't know quite how to respond to your question. The DOD announced that abuse was being charged, there were criminal investigations underway. No one had seen the photographs. They were part of a criminal investigation, and I say no one in the Pentagon had seen them. They were part of that CENTCOM investigative process. It is the photographs that give one the vivid realization of what actually took place. Words don't do it. The words that there were abuses, that it was cruel, that it was inhumane, all of which is true—that it was blatant—you read that, and it's one thing. You see the photographs, and you get a sense of it, and you cannot help but be outraged.

There are, at any given time, in the DOD, these 3,000 courts-martial underway—general courts-martial, some 1,200; criminal investigations, 18,000 last year. The importance of protecting the people charged, protecting their rights, and the importance of seeing that if, in fact, they're guilty, they don't get off because of command influence—so there's a pattern of not reaching down into those things, bringing them up, and looking at all the evidence before it ever arrives. In this case, it was released to the press.

Now, we announced the problem to the press. We did not release the Taguba Report to the press. That was done by someone, to release, against the law, a secret document. That's how it surprised everyone. It shocked Congress. It shocked me. It shocked the President. It shocked the country.

But to suggest that they had not taken tough, swift, corrective actions in CENTCOM, it seems to me is inconsistent with what took place.

Senator COLLINS. Mr. Secretary, that's not what I said. What I said is—and I have no doubt that the military is committed to swift corrective action—it's the disclosure of the abuse, and the promise to take those actions. That's where I feel the Pentagon fell short. I think that rather than calling CBS and asking for a delay in the airing of the pictures, it would have been far better if you, Mr. Secretary, with all respect, had come forward and told the world about these pictures and of your personal determination—a determination I know you have—to set matters right and to hold those responsible accountable.

Secretary RUMSFELD. Senator Collins, I wish I had done that, as I said in my remarks. We have to find a better way to do it, but I wish I knew how you reach down into a criminal investigation when it is not just a criminal investigation, but it turns out to be

something that is radioactive, something that has strategic impact in the world. We don't have those procedures. They've never been designed. We're functioning with peacetime constraints, with legal requirements, in a wartime situation, in the information age where people are running around with digital cameras and taking these unbelievable photographs, and then passing them off, against the law, to the media, to our surprise, when they had not even arrived in the Pentagon. There isn't a person at this table, except General Smith, who had even seen them.

Chairman WARNER. You're free to amplify that for the record, if you wish, Mr. Secretary.

Senator Akaka.

Secretary Rumsfeld. Thank you, Mr. Chairman.

Secretary Rumsfeld, according to General Taguba's report, civilian contractors were found wandering around Abu Ghraib unsupervised and with free access to the detainee areas. I have two questions on that. What are the roles of the private contractors at this and other detention facilities in Iraq and Afghanistan? Who monitors and supervises these contracted employees?

Secretary RUMSFELD. The answer is that the civilian contractors, as I indicated, numbered something like 37 in this particular facility. They tend to be interrogators and linguists. They're responsible to MI personnel who hire them and have the responsibility for supervising them.

Mr. BROWNLEE. Sir, if I might?

Senator AKAKA. Secretary Brownlee.

Mr. BROWNLEE. In the theater, we have employed civilian contract interrogators and linguists. CENTCOM has done this. These people have no supervisory responsibilities at all. They work under the supervision of officers or noncommissioned officers (NCOs) in charge of whatever team or unit they are on. They, most of them, are retired military, and they are usually of the skill that they retired in, and that's what they're employed for. They assist in these processes, but they are not in a supervisory role. In fact, they would be forbidden from doing that, because it would be inherently governmental.

General SMITH. Sir, I might add to that. In this particular case, there is a "tiger team" that interrogates and goes through that process. One is an interpreter, normally; one is an analyst; and one is an interrogator. Where we have shortages in the military of interrogators and translators, we go to contractors to do that.

I gave the wrong numbers. The number of contractors we have with CACI for interrogators is 27. Then we have hundreds of translators that are under contract throughout the country, under Titan Corporation.

Senator AKAKA. Secretary Rumsfeld, the alleged abuse at this detention facility has been characterized as sadistic, blatant, wanton, and criminal abuse. So far, we have discussed allegations against military members. Are there allegations of abuse against contractors who are working with the military members? If so, are any of these allegations being investigated?

Secretary RUMSFELD. My recollection is—and I think it's okay to say this—that the investigations are ongoing, and that time will tell.

Go ahead, General.

[Clarifying information from the DOD follows:]

David Passaro, a CIA contractor, was indicted Thursday, June 17, 2004, in connection with the beating death of a prisoner in Afghanistan. Passaro is the first civilian to face criminal charges related to U.S. treatment of prisoners in Afghanistan and Iraq.

Information on two other CACI contractors (Steve Stepanowicz and John Israel) has been forwarded to the U.S. Attorney General's Office by the U.S. Army CID to determine whether evidence supports criminal charges against these two contractors.

An ongoing investigation is reviewing the MI operations and includes a review of the actions of civilian contractors involved in interrogation activities.

General SMITH. Yes, sir. There are two contractors that are being investigated under the investigation for the MI brigade, and that is from the recommendation of the Taguba Report.

Senator AKAKA. Mr. Chairman, I want to say that I recently traveled to Iraq and Afghanistan, and I was so impressed with the professionalism of the men and women serving in our military who I had the opportunity to meet. I want to say that I am really proud of what they are doing there.

General Myers, General Taguba's AR 15-6 Report finds a general lack of knowledge, implementation, and emphasis of basic legal, regulatory, doctrinal, and command requirements within the 800th MP brigade and its subordinate units. Understanding that there is an issue with authority between the MP and MI units at Abu Ghraib, how is it that an entire brigade could be deployed to Iraq and not train for their mission?

Chairman WARNER. Senator, I'll have to ask that General Myers provide his response for the record.

[The information referred to follows:]

Enclosure 1

AFKA-OP
6 May 2004

INFORMATION PAPER

Subject: Mobilization and training outline for Detachment 3, Detachment 4, Detachment 6, Detachment 7, and Detachment 8 of the 800th Military Police Brigade

1. The 800th Military Police Brigade (EPW) deployed five detachments in support of operation Enduring Freedom to perform the duties of command and control for internment and resettlement military police assets. **Detachment (DET) 3**, home stationed at Hempstead, New York, mobilized eleven (11) soldiers in serial 174 for duty in Arifjan, Kuwait. The element reported to their mobilization station at Fort Dix, New Jersey on 05 January 2003. **Detachment (DET) 4**, home stationed at Hempstead, New York, mobilized three (3) soldiers in serial 177B1 to support Operation Enduring Freedom with duty in Arifjan, Kuwait. The unit reported to their mobilization station at Fort Dix, New Jersey on 19 January 2003. **Detachment (DET) 6**, home stationed at Uniondale, New York, mobilized forty three (43) soldiers in serial 177B1 to support Operation Enduring Freedom with duty in Arifjan, Kuwait. The unit reported to their mobilization station at Fort Dix, New Jersey on 19 January 2003. **Detachment (DET) 7**, home stationed at Hempstead, New York, mobilized twenty-one (21) soldiers in serial 187B to support Operation Enduring Freedom with duty in Tallil, Iraq. DET 7 reported to their mobilization station at Fort Dix, New Jersey on 21 January 2003. **Detachment (DET) 8** consisted of one commander, home stationed at Hempstead, New York, that was mobilized on 21 May 2003 and processed through the CONUS Replacement Center at Fort Benning, Georgia. Detachment 8 was the Brigade Commander. The 800th Military Police Brigade is a peacetime subordinate unit of the 77th Regional Readiness Command (U.S. Army Reserve).

2. Mobilization Timeline:

a. 800th MP BDE (EPW) DET 3

- (1) Alert Date: 14 December 2002
- (2) Mobilization Date: 02 January 2003
- (3) Mobilization Station Arrival Date: 05 January 2003
- (4) Validation Date: 15 January 2003. Validated by the Fort Dix mobilization station commander at T-1.
- (5) Deployment Date: 26 January 2003
- (6) Duty Date: 27 January 2003

b. 800th MP BDE (EPW) DET 4

- (1) Alert Date: 01 November 2001
- (2) Mobilization Date: 16 January 2003
- (3) Mobilization Station Arrival Date: 19 January 2003
- (4) Validation Date: 27 January 2003. Validated by the Fort Dix mobilization station commander at T-1.

(5) Deployment Date: 20 February 2003

(6) Duty Date: 21 February 2003

c. 800th MP BDE (EPW) DET 6

(1) Alert Date: 01 November 2001

(2) Mobilization Date: 16 January 2003

(3) Mobilization Station Arrival Date: 19 January 2003

(4) Validation Date: 11 February 2003. Validated by the Fort Dix mobilization station commander at T-1.

(5) Deployment Date: 20 February 2003

(6) Duty Date: 21 February 2003

d. 800th MP BDE (EPW) DET 7

(1) Alert Date: 01 November 2001

(2) Mobilization Date: 10 February 2003

(3) Mobilization Station Arrival Date: 21 February 2003

(4) Validation Date: 04 June 2003. Validated by Fort Dix mobilization station commander at T-2.

(5) Deployment Date: 08 June 2003

(6) Duty Date: 09 June 2003

e. 800th MP BDE (EPW) DET 8

(1) Alert Date:

(2) Mobilization Date: 21 May 2003

(3) Mobilization Station Arrival Date: 08 June 2003

(4) Validation Date: 13 June 2003. Validated by the Fort Benning mobilization station commander. No "T" rating since individual mobilized at CRC.

(5) Deployment Date: 18 June 2003

(6) Duty Date: 19 June 2003

3. The unit manning requirements:

a. 800th MP BDE (EPW) DET 3--The unit was authorized 12 personnel. It was assigned 11 personnel. The detachment deployed 11 soldiers.

b. 800th MP BDE (EPW) DET 4--The unit was authorized 3 personnel. It was assigned 3 personnel. The detachment deployed 3 soldiers.

c. 800th MP BDE (EPW) DET 6--The unit was authorized 43 personnel. It was assigned 43 personnel. Three (3) were medical holds, pending medical review, and one soldier was non-deployable. The detachment deployed 39 soldiers.

d. 800th MP BDE (EPW) DET 7--The unit was authorized 24 personnel. It was assigned 25 personnel. Three (3) were medical holds, pending medical review, one soldier was non-deployable. The detachment deployed 21 soldiers.

e. 800th MP BDE (EPW) DET 8--The unit was authorized 1 Cdr. It was assigned and deployed 1 soldier.

4. Mobilization station activities at Fort Dix and Fort Benning:

a. Units mobilized at Fort Dix completed Soldier Readiness Processing (SRP), which included Medical, Dental, Personnel, Finance, Legal, and Security. All soldiers were issued the required organizational clothing and individual equipment (OCIE) and Joint Service Lightweight Integrated Suit Technology (JSLIST).

b. As required by Forces Command, post mobilization training consisted of:

(1) Individual Readiness Training (Cultural and Religious Awareness, Rules of Engagement (ROE) and Rule for Use of Force (RUF), SAEDA, Media Awareness, and Anti terrorism (AT) Level 1, Reaction to indirect fire, Mine awareness, and Risk Management / Assessment).

(2) NBC Tasks

(3) First Aid Tasks / Combat Life Saver

(4) Theater Specific Individual Requirements Training (TSIRT) Briefings

(5) Weapons Qualification

c. Mobilization of unit in small detachments did not support collective training of 800th Military Police Brigade Headquarters.

d. The Commander processing through the CONUS replacement center at the Fort Benning was trained in the following tasks: Rules of Engagement, Protective Mask Fitting, Biological/Chemical Warfare Prevention & Protective Measures, Country Overview/Anti-Terrorism, Medical Threat Brief, Preliminary Marksmanship Instruction, Individual Weapons Qualification, Improvised Explosive Devices, Unexploded Ordnance, and Subversion and Espionage Directed against the Army (SAEDA)/Operations Security.

POC: LTC Jimmie Ring, 464-6303, ringjis@forscom.army.mil.

Tab 1

Tab 1

Subject: Mobilization and training outline for Detachment 3, Detachment 4, Detachment 6, Detachment 7, and Detachment 8 of the 800th Military Police Brigade

1. Information provided by MG Burns, 11 May 04:

2. 800th MP Brigade's METL [tasks] at the time of their mobilization. Detachment 6 (the largest detachment of 43 personnel) provided the mobilization station at Ft Dix a copy of the Brigade's METL and supporting collective task pre-AT assessment from 26 June 2002.

<u>METL (M) /supporting collective Task (S)</u>	<u>Assessment</u>	<u>Reference</u>
(M) Ensure mobility and survivability	P	ARTEP 19-472 MTP
(S) Occupy a site	P	ARTEP 19-472 MTP
(S) Prepare for displacement	P	ARTEP 19-472 MTP
(S) Conduct a convoy	P	ARTEP 19-472 MTP
(S) Defend unit position	P	ARTEP 19-472 MTP
(S) Establish company defensive position	P	ARTEP 19-472 MTP
(S) Treat casualties	T	ARTEP 19-472 MTP
(S) Conduct battlefield stress reduction and	T	ARTEP 19-472 MTP
Prevention procedures		
(M) Coordinate internment/resettlement operations	T	AUTL
(S) Support staff training to assist subordinate units	T	AUTL
in performing EPW/CI internment		
(M) Force Protection/ Anti-Terrorism	P	ARTEP 19-472 MTP
(S) Maintain OPSEC	T	ARTEP 19-472 MTP
(S) Provide NBC support	T	ARTEP 19-472 MTP
(S) Prepare for a chemical attack	P	ARTEP 19-472 MTP
(S) Respond to a chemical attack	P	ARTEP 19-472 MTP
(S) Prepare for a nuclear attack	T	ARTEP 19-472 MTP
(S) Cross a radiological contaminated area	P	ARTEP 19-472 MTP

(S) Conduct operational decon	P	ARTEP 19-472 MTP
(M) Alert, mobilize and deploy	P	FORSCOM Reg 500-3
(S) Conduct mob station activities	P	FORSCOM Reg 500-3
(S) Conduct Soldier Readiness Processing	T	FORSCOM Reg 500-3
(S) Conduct alert and recall	P	FORSCOM Reg 500-3
(S) Conduct home station activities	P	FORSCOM Reg 500-3

Enclosure 2

AFKA-OP
6 May 2004

INFORMATION PAPER

Subject: Mobilization and Training Outline for the Headquarters and Headquarters Company, 320th Military Police Battalion, Enemy Prisoner of War, Counterintelligence, Detachment 2

1. The 320th Military Police Battalion, HHC, (EPW/CI), is home stationed at Ashley, Pennsylvania as part of the 800th Military Police Brigade and is subordinated to the 99th Regional Readiness Command (U.S. Army Reserve) in peacetime. Detachment 2 was directed to mobilize in serial 187B to support Operation Enduring Freedom as an Internment and Resettlement (IR) unit. Initial deployment duty location was identified as Tallil, Iraq. The unit reported to their mobilization station at Fort Dix, New Jersey on 19 February 2003, validated on 11 March 2003 and deployed on 13 March 2003. The unit returned to Fort Dix on 18 March 2004, demobilized and returned to their home station on 24 March 2004.

2. Mobilization Timeline:

- a. Alert Date: 1 January 2003
- b. Mobilization Date: 10 February 2003
- c. Mobilization Station Arrival Date: 19 February 2003
- d. Validation Date: 11 March 2003. Validated by Fort Dix mobilization station commander at T-1.
- e. Deployment Date: 13 March 2003
- f. Duty Date: 14 March 2003
- g. Redeployment Date: 18 March 2004

3. The unit was authorized 148 personnel. It was assigned 148 personnel. One soldier was placed on medical hold, three soldiers were placed on dental hold, and two additional soldiers were identified as non-deployable. The detachment deployed 142 soldiers.

4. Mobilization station activities at Fort Dix:

a. While mobilized at Fort Dix, the unit completed Soldier Readiness Processing (SRP), which included Medical, Dental, Personnel, Finance, Legal, and Security. All of the units' equipment received a technical inspection and was brought to fully mission capable condition (FMC). All soldiers were issued the required organizational clothing and individual equipment (OCIE) and Joint Service Lightweight Integrated Suit Technology (JSLIST).

b. As required by Forces Command, post mobilization training consisted of:

(1) FY03 Common Task Training Tasks (CTT) for Skill Level 1-4

(2) Individual Readiness Training (Cultural and Religious Awareness, Rules of Engagement (ROE), SAEDA, Media Awareness, and AT Level 1). The Rules of Engagement training included general information on the handling and treatment of prisoners.

(3) NBC Tasks

(4) First Aid Tasks

(5) Theater Specific Individual Requirements Training (TSIRT) Briefings (Nine Line Medical Evacuation (Medevac), Depleted Uranium, Force Protection, etc.)

(6) Weapons Qualification (Individual and Crew Served)

c. Collective Training. Records indicate that the unit trained on the following collective tasks:

(1) Tactical Operations Center (TOC) Operations

(2) Battle Staff Training

d. Additionally records indicate that the unit was rated as a "P" in the following collective mission essential task list (METL) tasks upon arrival at the mobilization station.

(1) Establish and sustain an internment and resettlement facility

(2) Process and account for internees

(3) Anti terrorist and force protection operations

e. Due to theater requirements, the collective training of this unit was unusually compressed, with a total of 20 days available from arrival at the mobilization station to required validation date, including all soldier readiness processing (SRP) and individual and collective training.

5. POC: LTC Jimmie Ring, 464-6303, ringjs@forscom.army.mil.

Enclosure 3

AFKA-OP
6 May 2004

INFORMATION PAPER

Subject: Mobilization and training outline for the 372d Military Police Company

1. The 372d Military Police Company is home stationed at Cumberland, Maryland as part of the 99th Regional Readiness Command (U.S. Army Reserve). They were directed to mobilize in serial 187B to support Operation Iraqi Freedom as a Combat Support Military Police Company, with expected deployment to Silopi, Turkey. The unit reported to their mobilization station at Fort Lee, Virginia on 27 February 2003. On 29 March 2003, FRAGO 5 to DEPORD 187B was issued redirecting the unit to Kuwait as a Combat Support Military Police Company.
2. Mobilization Timeline:
 - a. Alert Date: 06 January 2003
 - b. Mobilization Date: 24 February 2003
 - c. Mobilization Station Arrival Date: 27 February 2003
 - d. Validation Date: 14 April 2003. Validated by the Fort Lee mobilization station commander at T-1.
 - e. Deployment Date: 13 May 2003
 - f. Duty Date: 14 May 2003
3. The unit was required and authorized 180 soldiers.
 - a. Unit arrived at Fort Lee with 180 soldiers.
 - b. Seventy-two of their soldiers had been assigned to the unit since their last annual training (AT).
 - c. Fifty-six of the remaining 108 soldiers had recently returned from a rotation on SFOR 10.
 - d. Ten soldiers were found not medically fit and did not deploy with the unit; 2 later deployed and joined the unit, 6 have already been released from active duty and 2 remain at Fort Lee as Medical Holds (one soldier is being medically separated and will leave in 1-2 weeks; the second Soldier's Medical Evaluation Board (MEB) packet will go to the Physical Evaluation Board (PEB) this week, will potentially be at Fort Lee for another 3-4 months).
 - e. Fifteen soldiers returned to Fort Lee during the deployment for administrative or medical reasons. Four have redeployed, one was given a Hardship Discharge (Chapter 6), nine were released from active duty and one remains at Fort Lee.
 - f. Thirty-four soldiers have returned from theater under the 730-day rule and have been released from active duty.
4. Mobilization station activities at Fort Lee and Fort Picket.
 - a. While mobilized at Fort Lee, the unit completed Soldier Readiness Processing (SRP), which included Medical, Dental, Personnel, Finance, Legal, and Security. All of the units' equipment received a

technical inspection and was brought to fully mission capable condition (FMC). All soldiers were issued the required organizational clothing and individual equipment (OCIE) and Joint Service Lightweight Integrated Suit Technology (JSLIST).

b. As required by Forces Command, post mobilization training consisted of:

- (1) FY03 Common Task Training Tasks (CTT) for Skill Level 1-4
- (2) Individual Readiness Training (Cultural Awareness, Rules of Engagement (ROE), SAEDA, Media Awareness, and AT Level 1). The Rules of Engagement training included general information on the handling and treatment of prisoners.
- (3) NBC Tasks
- (4) First Aid Tasks
- (5) Theater Specific Individual Requirements Training (TSIRT) Briefings (Nine Line Medical Evacuation (Medevac), Depleted Uranium, Force Protection, etc.)
- (6) Weapons Qualification (Individual and Crew Served)

c. Collective training consisted of:

- (1) Live Fire Exercise (M16/9MM)
- (2) Dismounted Combat Maneuver
- (3) Military Operations in Urban Terrain (MOUT) Training

d. The unit continued to conduct training after validation for deployment and the shipment of their equipment, however the unit maintained those training records.

5. POC: LTC Jimmie Ring, 464-6303, ringjs@forscom.army.mil.

Chairman WARNER. I thank you for your cooperation.

Senator AKAKA. Thank you very much. Mr. Chairman, I have a written statement that I would like to submit for the record.

Thank you for your responses.

[The prepared statement of Senator Akaka follows:]

PREPARED STATEMENT BY SENATOR DANIEL K. AKAKA

Thank you, Mr. Chairman. I want to take this opportunity to express my thoughts regarding the deplorable acts committed by soldiers at the Abu Ghraib prison. The graphic and disturbing acts that are depicted in these pictures are inexcusable. These actions have tarnished the heroic and patriotic acts performed by so many of our military members during this difficult war.

I recently traveled to Iraq and Afghanistan. I was so impressed with the professionalism exhibited by the men and women serving in our military who I had the opportunity to meet. Unfortunately, the rest of the world and the Nation will not see or hear about these outstanding individuals. Instead these pictures published on the front pages of newspapers around the world depict our military members as thugs.

This outcry has been exacerbated by the manner in which this situation has been handled. Members of Congress, even the President, according to media reports, learned about this situation from Dan Rather when "60 Minutes II" broadcast this story. I find this cloud of secrecy that continues to permeate the Department of Defense (DOD) disturbing and destructive. I find this cavalier attitude towards accountability and transparency to be a dereliction of duty and an abrogation of military and civilian control over the "post-war" situation.

I find it amazing that Secretary Rumsfeld stated as late as Monday, May 3, 2004, that he had not yet read the AR 15-6 Report written by Major General Antonio Taguba which was submitted in March 2004. I find it unconscionable that soldiers being deployed to a war zone would not be provided with proper training pertaining to the treatment of detainees under the Uniform Code of Military Justice (UCMJ) and the Geneva Conventions.

I am troubled by the apparent lack of accountability by DOD leadership. In my opinion, for these soldiers to be so cavalier and nonchalant as depicted in these photos, which had to have been taken by other detention facility personnel, tells me that such behavior was widespread and condoned in this prison.

I remain concerned with the lack of supervision and discipline in this brigade and even more concerned with the unsupervised and unlimited access private contractors had inside this facility. I remain disturbed by the dismissive attitude exhibited by the civilian leadership in the Pentagon towards this situation which has undermined our military and damaged our country's reputation.

Chairman WARNER. Senator Graham is next.

Senator GRAHAM. Mr. Secretary, have you seen the video?

Secretary RUMSFELD. I have not. The disk I saw that had photos on it did not have the videos on it. I checked with General Smith, and he indicates he does have a disk with the videos on it. I don't know if that means there are two disks with all these photographs, or if the photographs are the same, and one just doesn't have the video.

Senator GRAHAM. I mention that because I want to prepare the public. Apparently the worst is yet to come, potentially, in terms of disturbing events. We don't need to leave here thinking that we've seen the worst. There's more to come. Is that correct?

Secretary RUMSFELD. I indicated in my remarks that there are a lot more pictures and many investigations underway.

Senator GRAHAM. My colleagues, rightly, want it done quickly, but my concern is to do it right. I don't want to rush to judgment here and let some people go that deserve to be prosecuted. I would be very disappointed if the only people prosecuted are sergeants and privates. That would be very bad, and sad. So I want it done right, and the sooner, the better. I'll pick right over sooner.

I'm confused. General Smith, when did you first learn of these photos and see them yourself?

General SMITH. Sir, we knew that there were photos on January 14, because that's how the investigation started.

Senator GRAHAM. When did you see the photos?

General SMITH. CENTCOM headquarters received the photos towards the end of March. I first viewed the photos on May 6.

Senator GRAHAM. Who did you tell about the photos when you saw them?

General SMITH. Sir, that was part of the investigation, and that went forward.

Senator GRAHAM. Did it dawn on you that, when you saw these photos, "We're in a world of hurt. This is going to look bad"?

General SMITH. Certainly, sir. If those were released, we certainly—

Senator GRAHAM. General Myers, when you called CBS, had you seen the photos?

General MYERS. No, I hadn't.

Senator GRAHAM. What had you been told about what CBS was about to air, and by who?

General MYERS. They were going to air the photos. We didn't talk about that with CBS. In our discussions back in January, when they said there were photos, they described them up through the chain of command to the Secretary, and I just happened to be there. It was discussed several times. The general nature of the

photos, about nudity, some mock sexual acts, and other abuse, was described.

Senator GRAHAM. When you were informed that these photos, even though you hadn't seen them, were going to come out, who did you tell about that, and when?

General MYERS. There were a lot of people that knew, inside our building. The people that had been working with the media knew that there were photos out there, and the media was trying to get their hands on them from January on. So they had been working that for 3 months.

Senator GRAHAM. At that time, is it fair to say you knew there was a story about to come out that was going to create a real problem for us?

General MYERS. At that time, my concern was the impact it could have on our forces in Iraq. My focus at the time was, if these photos are revealed right now, given the intensity of operations, what could be that impact on our troops? My conclusion was, this would be the worst of all possible times for these to come forward; realizing that eventually they were going to come forward.

Senator GRAHAM. Did you feel a need to inform Congress or the President or the Secretary of Defense about the potential damage this could do?

General MYERS. We had discussed the potential damage back in January, February, and March. As we marched through those events on that chart, a lot of those events were based on our concern with where this might lead.

Senator GRAHAM. Long story short, I do trust the people in uniform to get it right, and I want to take the time necessary to make sure the people who are responsible are brought to justice, and anybody innocently accused has their day in court. You are right about that, Secretary Rumsfeld.

Here's the problem. It doesn't take a rocket scientist to figure out the explosive nature of these photos, apart from court-martial, apart from legal proceedings. Most of us here found out about it on television. If we knew enough to say, "Don't air a show that's going to be bad," why did we not call the President and call senior Members of Congress to prepare us for what we were eventually going to see? That's the essence of my concern about all this.

General MYERS. Senator Graham, in my opinion we could have done a better job of informing Congress of these pictures and this situation.

Senator GRAHAM. That is a honest and fair answer.

Secretary Rumsfeld, people are calling for your resignation. Somebody is drafting an article of impeachment against you right now. I have my own view about people who want to call for your resignation before you speak, but I'll leave that to myself. Do you have the ability, in your opinion, to come to Capitol Hill and carry the message and carry the water for the DOD? Do you believe, based on all the things that have happened and that will happen, that you're able to carry out your duties in a bipartisan manner? What do you say to those people who are calling for your resignation?

Secretary RUMSFELD. It's a fair question. Certainly, since this firestorm has been raging, it's a question that I've given a lot of

thought to. The key question for me is the one you posed, and that is whether or not I can be effective. We have tough tasks ahead. The people in the DOD, military and civilian, are doing enormously important work here, in countries all over the world. The issue is, can I be effective in assisting them in their important tasks? Needless to say, if I felt I could not be effective, I'd resign in a minute. I would not resign simply because people try to make a political issue out of it.

Chairman WARNER. Thank you, gentlemen.

Senator Bill Nelson.

Senator BILL NELSON. Thank you, Mr. Chairman.

Mr. Secretary, when did you first see the photos?

Secretary RUMSFELD. Last night, at about 7:30. I had seen the ones in the press, I had seen the ones that are doctored slightly to suit people's taste. We had been trying to get one of the disks for days and days and days, and I'm told, by General Smith, that there were only a couple of these, that they were in the criminal investigation process. Dick Myers and I finally saw them last night.

Senator BILL NELSON. Mr. Secretary, when did you first find out about the abuses?

Secretary RUMSFELD. With everybody else, when they were announced by CENTCOM on January 16. They announced that they had a series of criminal investigations underway. They told the world, Congress, me, everyone else, that they were underway. Then they came back March 20 and said, "Not only are they underway, but now we have specific charges." Then they detailed some abuses. You read it, as I said, and it's one thing; you see these photographs, and it's just unbelievable.

Senator BILL NELSON. When did you first tell the President, Mr. Secretary?

Secretary RUMSFELD. I don't know. Dick Myers and I see the President every week, and he recalls that sometime after we were apprised of it through the press, through CENTCOM's announcement, that it was brought up in one of our meetings. Do you recall?

General MYERS. I don't recall specifically, because I think the day it was brought up it was General Pete Pace that was standing in for me. But he remembers roughly when it was, within a week or so of when he was in that meeting and informed the President. They talked about it.

Senator BILL NELSON. Was this back in January, Mr. Secretary?

General MYERS. I think General Pace would say early February. It could have been late January.

Secretary RUMSFELD. I meet with the President once or twice a week. We cover 8, 10, 15 different points. General Myers or General Pace are generally there with me. I don't keep notes about what I do, and I just don't remember when it was.

Senator BILL NELSON. When you all had this discussion with the President, what did the President say that you should do about those abuses?

Secretary RUMSFELD. I don't know that I'm going to get into private discussions with the President. If I don't remember when it was, my guess is it was more an information item from us to him, where we were transmitting and saying, "Here's the problem." The problem, at that stage, was one-dimensional; it wasn't three-dimen-

sional, it wasn't video, it wasn't color. It was quite a different thing.

As I indicated in my remarks, if there's a failure, it is me. It is my failure for not understanding and knowing that there were however many there are of these things that could eventually end up in the public and do the damage they've done. But I certainly never gave the President a briefing with the impact that one would have had, had you seen the photographs or the videos. Let there be no doubt about that. He was just as blindsided as Congress and me and everyone else.

Senator BILL NELSON. Mr. Secretary, what are your instructions from the President to inform him of matters such as this?

Secretary RUMSFELD. I don't know that I'm going to—we have had so many discussions, and clearly a Secretary of Defense has the responsibility to try to put himself in the shoes of the President and say, "What ought a President know about all the tens of thousands of things that are happening in the DOD at any given time?" We sit down every week, and General Myers and I go through all the things that we have going on, and we pick and choose. We say, "What are the things that are appropriate? What do we owe him so that he can provide the kind of leadership that this country deserves? What is it that the Department's doing now that we can get in his head and apprise him of so that he knows about that?" It may be a contingency plan, it may be a problem of personnel. It just runs the gamut.

Chairman WARNER. Thank you, Senator.

Senator Dole.

Senator DOLE. Thank you, Mr. Chairman.

I certainly want to echo the sentiments of my colleagues and the American people by saying that I am extremely disappointed that any American, and especially one in uniform, would mistreat or humiliate another human being and commit such atrocious acts.

The acts depicted in those photographs shown around the world do not, in any way, represent the values of the United States of America or our Armed Forces. I know our military men and women serve their country with great honor.

The abuse of these Iraqi detainees is a serious issue, not just because it violated human rights; it also tarnished our Nation's credibility. Furthermore, the inflammatory actions of a few have provided our enemies with a lucrative venue to question American values and our true intentions in the war on terror. Unfortunately, a breakdown of discipline, combined with a handful of morally deficient individuals, has resulted in serious implications for our national security and the security of over 130,000 service members striving to accomplish our goals in Iraq.

Over the past year, through dedication and sacrifice and, I must emphasize, strong military leadership, our soldiers have made incredible breakthroughs. The United States and its allies have freed 50 million people from oppressive regimes, removed credible threats to our Nation's security, destroyed burgeoning terrorist incubators, and set two countries on the path to democratic and free market reform. In Iraq, 2,600 schools have been rehabilitated, and now more than 5½ million children are enriching their minds, free from the corruption of a repressive regime and its teachings.

Women now have a voice in their own government. All 240 hospitals in Iraq are open. More than 1,200 clinics have been established. On the streets and in the countryside each day, our military medical professionals offer assistance to the citizens of Iraq, in addition to caring for their own. After 30 years of being denied the most fundamental freedoms, today more than 170 independent newspapers are operating throughout Iraq, providing each member of that country an opportunity to participate in free and robust debate, and, yes, the opportunity to view those horrendous pictures.

Trust among the Iraqi people had slowly been established, bonds have been made, and, sadly for now, many of those bonds have been broken. This legislative body is absolutely correct in focusing on the root causes behind these instances of prisoner abuse, and doing everything within its power to ensure that such abuse never happens again. I would expect no less from the DOD. Transparency is of the utmost importance to our Nation's credibility and security.

Fundamental to our success in the global war on terror is winning the hearts and minds of freedom-loving people who are held captive by a violent few. We are not company to that violent element, and we denounce anyone who is.

Secretary Rumsfeld, the damage already done cannot be swept away, but it can be repaired. You touched briefly on your plan for a way ahead. Could you go into more detail on this plan? Will it require more or different troops, quicker processing of detainees, more Iraqi police involvement? You mentioned reparations. Could you please provide more details?

Secretary RUMSFELD. I don't think I used the word "reparations." I hope I used the word "compensation" for the detainees who were cruelly treated. I am told that we have lawyers who have looked into it, and we believe there are authorities where we can do that. It is my intention to see that we do it, because it is the right thing to do.

With respect to the processing of detainees, in Iraq a total of 43,671 were captured. We have released 27,796, and transferred 4,054. We currently detain something in the neighborhood of 11,821, which includes 3,842 of the so-called Majahedim-e Khalq Organization (MEK), who are really not detainees. They are in a separate status. So it's really closer to 7,000 or 8,000 that are currently detained.

The key is to process them as rapidly as possible. General Miller, who was out there and has been addressing all of these things, also believes a key element is to see that they are properly identified, and that their families know they're there, and why they're there, and that it isn't mysterious, and that we continue to process them. The only people that need to be retained, obviously, are the ones that are either criminals—and that's a different category, and a number of them are—or they are individuals who are terrorists and need to be kept off the street, or they have intelligence value. The people have to find out what it is they know so we can track down the remaining remnants of the Baathist regime and the Fedayeen Saddam people, and the people that are out killing Iraqis—not just Americans and coalition people, but are killing Iraqis every single day in that country.

Chairman WARNER. Thank you very much, Senator.

Senator DOLE. Thank you.

Chairman WARNER. Senator Ben Nelson.

Senator BEN NELSON. Thank you, Mr. Chairman. Thank you, Mr. Secretary and gentlemen, for being here today.

First of all, I appreciate the apologies. Clearly, the President's apology, I think, is an important step in moving forward, as are the apologies of all of you today, and, I think, the apology of the American people, for these unfortunate incidents.

I agree with my colleague from Connecticut that what this represents is so unfortunate that it somehow would adversely impact on the lives and the deaths of those who have served with such distinction for freedom in Iraq.

Last night, I heard Secretary Armitage say that, "We're in a bit of a hole." I think those are exact words. When you're in a hole, the first thing you have to do is stop digging. I hope that we have now gotten to the point where we've stopped digging, where we're not making matters worse.

Mr. Secretary, you're right when you say there are times when words just simply don't do it justice. Pictures, and perhaps symbols, are more important for expressing or conveying thoughts or images. In this case, I think tearing down the statue of Saddam, statues all over Iraq, was a symbolic gesture to say that there was a new era. I wonder if it wouldn't be just as important to join together to tear down Abu Ghraib as a statement that the torture chamber of Saddam that carried forth past and present is no longer, and create a memorial to freedom in the future, and the absence of tyranny of any kind.

But what I want to do is, I want to get to a question dealing with what seems to be an operative word today: "the few." I think perhaps there are sergeants and privates, as Senator Graham indicated, who have been involved in this activity. Obviously, the chain of command would be under consideration here. Criminal action will be taken. I suspect responsible action will be taken, in terms of the chain of command.

Is it the aberrant behavior of a few, or can we expect to have, out of the investigation, an indication that there was something more systemic? I know that we have a two-star Reserve general who has been in some way removed from duty, but isn't there, to date, some expectation that there was a severing of the chain of command somewhere along the line, through MI or other intelligence operations coming in? It's my understanding that there are reports that General Karpinski was banned from sections of her own prison system.

I am hopeful that we'll be able to get to the bottom of that with the reports. In the interim, is there anything that you might be able to enlighten us with right now?

Secretary RUMSFELD. Let me answer a couple of pieces, and let General Smith answer the last piece.

First, you say the first rule if you're in a hole is to stop digging. I've said today that there are a lot more photographs and videos that exist.

Senator BEN NELSON. I didn't mean that. Is anything progressing on today, beyond what we already know or what we're going to find out from past performance?

Secretary RUMSFELD. If these are released to the public, obviously it's going to make matters worse. That's just a fact. I looked at them last night, and they're hard to believe. So, be on notice. That's just a fact. If they're sent to some news organization, and taken out of the criminal prosecution channels that they're in, that's where we'll be, and it's not a pretty picture.

Second, there are people who were talking about the Abu Ghraib prison and tearing it down, and certainly that's something that the CPA and the Iraqi Governing Council (IGC) and the Iraqi government, the interim government that will take over by June 30, will be addressing and deciding. Frankly, from my standpoint, I think it's not a bad idea, but it's really up to the Iraqis.

Senator BEN NELSON. Thank you, Mr. Chairman. Thank you, Mr. Secretary.

Chairman WARNER. Senator Cornyn.

Senator CORNYN. Thank you, Mr. Chairman.

Mr. Secretary, listening to the questions and the answers that have been given so far leads me to at least tentatively conclude that there are two major problems here. One is, first, the shock to our collective conscience at what we have seen human beings do to degrade and abuse other human beings. Second, the shock to our sensibilities as Members of Congress who have a collective responsibility to the American people, to see these pictures in the press. I believe that it was General Myers who talked about what we have seen as being a violation of American values. I agree with that, but I also want to talk about other American values. General Myers alluded to this when he talked about due process, and you mentioned the issue of command influence.

First, I would like to direct your attention back to the news release that CENTCOM issued on January 16, 2004, announcing this investigation. The second and third sentences, I want to direct your attention to specifically. This news release says, "This release of specific information concerning the incidents could hinder the investigation, which is in its early stages. The investigation will be conducted in a thorough and professional manner."

I think what the American people expect of all of us here is not only that we have high standards of conduct, which I know the military subscribes to, but we have the training, the oversight, the leadership, the accountability, and also the due process and desire to seek justice when it comes to holding people accountable for their crimes. I want to tell you that what you've described here, in terms of this chronology of investigation, gives me confidence that the DOD has taken this matter as seriously as it should have. Indeed, as you and others have said, not all the facts are in yet. But I do see on this chronology that, indeed, after this investigation, there have been criminal charges preferred against some who are guilty of these crimes. I would ask you, please, just to briefly talk about your obligation, in terms of seeing that the persons who are accused of these crimes get that due process, and to make sure that you maintain the integrity of the investigation by not dripping information out on this incident in a piecemeal basis over the course of the next few months.

Secretary RUMSFELD. You have your finger on the dilemma, on the tension that exists between assuring that you protect the rights

of individuals that are in a serious, difficult criminal prosecution circumstance, and avoiding saying things that either would infringe on their rights or would enable them to escape punishment by virtue of being able to successfully allege that command influence was exercised in a way that prejudiced the decisions up the chain of command. So we have that problem. To the extent senior people in the DOD dive down in and start looking in criminal prosecutions in the early and mid-stages, the hue and outcry would be horrendous. On the other hand, if you have a situation where something like this is buried in there, along with 3,000 other courts-martial, and buried in there is something of this significance, we have to find a way to know that. Our country doesn't need those kinds of shocks, and the troops don't need it.

Chairman WARNER. Senator, I have to thank you. We must move on. The panel leaves here and goes over to the House Armed Services Committee.

Secretary RUMSFELD. We'll have to leave by about 2:30, Mr. Chairman.

Chairman WARNER. That is correct. That was made clear, and I think we will have sufficient time to include our next Senator, Senator Bayh, followed by Senator Chambliss, Senator Clinton, Senator Pryor, and Senator Dayton.

Senator BAYH. Thank you, Mr. Chairman.

Thank you, gentlemen, for being here today and, in addition to that, for serving our country. These are difficult times, and your service is not without some personal cost. I am going to assume some facts up here and then ask what I think may be two somewhat difficult questions.

I assume that you serve at the pleasure of the President. I assume that he sets a policy for our national security, in general, and for Iraq, in particular. I assume that he is engaged in overseeing the implementation of those policies and, like you, accepts responsibility for that implementation. This is a long way of saying, as Senator Byrd mentioned, that in our system we have a tradition of the buck stopping at 1600 Pennsylvania Avenue. As we're all aware, we're now engaged in a debate about who the occupant of that residence will be, come next January.

So in many respects, I view this as a question of presidential leadership. How does he react? How aggressively? Does he try and minimize the situation, or does he try and take dramatic steps to address the magnitude of the problem? As has been noted, he has apologized for what took place. As all of you have indicated, particularly you, Mr. Secretary, the criminal process will move forward. That is a hallmark of our system of justice.

One of the questions that's overhanging this proceeding today, and the situation in general, is, is that enough? So the difficult question I'd like to ask is to follow up on the question from Senator Graham. Mr. Secretary, I could tell that you struggled in answering his question, that this is something that's been on your mind. Your resignation has been called for. That's a pretty serious thing for any of us. You answered that if you ever concluded that you could not be effective in discharging your duties, you would step down, but that you would not do so as a part of a political "witch hunt," so to speak.

There's another aspect of this, though, I'd like to ask your opinion about. I know it's ultimately a decision for the President to make, but, in your opinion, even though you weren't personally involved in the underlying acts here, would it serve to demonstrate how seriously we take this situation, and, therefore, help to undo some of the damage to our reputation, if you were to step down?

Secretary RUMSFELD. That's possible.

Senator BAYH. I appreciate your candor.

My second question has to do with some comments that Senator Lieberman made, and I would like to associate myself with what I thought were very appropriate and moving comments by Senator Lieberman. I believe very strongly that our cause—and these are not words I use frequently—but that our cause is morally superior to our adversaries', both the terrorists we fight and those who now seek to undo the future of a free Iraq. There is growing concern by the supporters of this cause that this situation we're inquiring into today is part of a broader problem, that the effort may be bogging down, that we may be approaching a tipping point, that momentum needs to be regained if we're going to prevail.

I'd like to just read a couple of sentences from a column in yesterday's New York Times by Tom Friedman, who supported this endeavor in Iraq. He says, "We are in danger of losing something much more important than just this war in Iraq. We are in danger of losing America as an instrument of moral authority and inspiration in the world. This administration needs to undertake a total overhaul of its Iraq policy; otherwise, it is courting a total disaster for us all." He goes on to say how he hopes that such an overhaul can be undertaken, because we need to prevail in Iraq.

So my final question is, Mr. Secretary, do you believe we're on the right course presently, or is dramatic action necessary to regain the momentum so that we can ultimately prevail in what is a very noble and idealistic undertaking?

Secretary RUMSFELD. I do believe we're on the right track. It's a tough road. It's a bumpy road. It's always been bumpy going from a vicious dictatorship to something approximating a representative government that's respectful of its different varied religious and ethnic groups. That's not an easy path.

I am convinced that we are doing exactly what ought to be done, and that is to pass responsibility for that country to the Iraqis. I am convinced we're doing exactly what ought to be done in recognizing that they need to have the ability to provide for their own security, which is why so much effort's gone into developing police and civil defense corps and an army and border patrols and site-protection people.

They do not want Americans or coalition forces in their country over a prolonged period, and, goodness knows, we don't want to be there. The only proper way to pass it off is if they have their own security forces, which is why we're spending the money and making the effort. It's why General Abizaid and General Sanchez and General Petraeus now are over there working that problem. I think that we have a crack at doing it.

[Clarifying information from the DOD follows:]

LTG Petraeus was not in Iraq at the time of this hearing. LTG Petraeus was in Iraq from March 2003 to March 2004 as commander of the 101st Airborne Division

and returned for a second tour in late May 2004 to train Iraqi Civil Defense Corps battalions.

Secretary RUMSFELD. I don't think it will be smooth. I think it will be rough. It will be bumpy. But if you don't take your hand off the bicycle seat, you're not going to be able to ride the bike, and we have to do that. We're going to do that.

Chairman WARNER. Thank you very much, Mr. Secretary, Senator Bayh.

Senator Chambliss.

Senator CHAMBLISS. Thank you very much, Mr. Chairman.

Mr. Secretary, it's interesting that Senator Roberts and I had previously been talking about the fact that one thing that probably should be done is exactly what Senator Ben Nelson just recommended, and that's tear down that wall—and that wall is Abu Ghraib prison—to show another sign of the destruction of Saddam Hussein.

Mr. Secretary, there are different kinds of leaders. Different leaders even provide different kinds of leadership. One easy thing for a leader to do is sometimes hide behind the lower echelon in the chain of command. I just want to say to you, I've been prepared to be very critical of you if I needed to be critical today. But by your coming in here and making an admission, as a strong leader, that a mistake was made and that you're going to be doing whatever is necessary to correct that mistake, that shows just what kind of leader you are. Anybody who questions your effectiveness and your ability to lead the United States military has had their question answered today. So, for that, I commend you.

I commend you also for your selection of General Miller. I've been to Guantanamo twice. I was worried about what might happen down there with respect to those detainees. I had the privilege to observe several different interrogations. I think I was there the day that General Miller first arrived, as a matter of fact. I observed random interrogations down there. General Miller did correct a problem that existed. There were charges of abuse that were much slighter than these charges of abuse, and General Miller dealt with those swiftly and directly.

I am concerned, though, about a couple of different things. First of all, General Ryder did make his report following his visit to Abu Ghraib from the period of October 13 to November 6. We had a United States Army general doing an investigation of a prison and the activities that were ongoing in that prison during a point in time when these alleged atrocities took place. Now, my understanding from General Ryder is that he was never told about any of this while he was there. I don't understand that. I don't understand how the chain of command could be so faulty within that system to allow that to happen.

The only answer I ever got was that these atrocities occurred on the night shift. Well, the Army doesn't operate 12 hours a day. We operate 24 hours a day, and there is a failure in the chain of command that I hope you're in the process of addressing very directly from that standpoint.

Also, in response to Senator McCain, you made two comments—first of all, that guards are trained to guard people, not interrogate; and that guards are trained in the requirements of the Geneva

Conventions. Now, I understand those are policies of the DOD, as well they should be. But the fact of the matter is, when you look at page 10 of the Taguba report, you find out that was not done in this case. These MPs simply were not trained in what they were supposed to be doing.

So, again, I hope your folks are moving in the direction of making that correction with respect, particularly, to reservists that are brought onboard. One obvious judgment is that the 800th MP Brigade was totally dysfunctional, from Brigadier General Karpinski on down, with few exceptions. On the surface, you could portray the 800th MP Brigade as a Reserve unit with poor leadership and poor training. However, the abuse of prisoners is not merely a failure of an MP brigade. It is a failure of the chain of command, Mr. Secretary.

I want to leave here today knowing and taking comfort in the fact that, as Senator Graham said, we're not going to just prosecute somebody with one stripe on their sleeve or four stripes on their sleeve, but you're going to carry this thing to whatever extent is necessary to ensure that there's no "good old boy" system within the United States Army. Irrespective of whether they have a stripe on their sleeve or four stars on their shoulder, we're going to get to the bottom of this, and we're going to make sure that corrective action is taken, and, where necessary, criminal action is taken, against anybody involved in the particular acts or in the shielding of this and the failure or negligence on their part of keeping this information from you, in a quick and swift manner.

Secretary RUMSFELD. I agree with everything you've said, and there's no question but that the investigations have to go forward. They have to be respectful of people's rights, but they have to be handled in a manner that reflects the gravity of this situation. It does not matter one whit where the responsibility falls. It falls where it does.

Senator CHAMBLISS. Thank you, Mr. Secretary.

Chairman WARNER. Thank you very much, Senator.

General SCHOOMAKER. Senator Chambliss, I'd like to—

Chairman WARNER. General.

General SCHOOMAKER. Mr. Chairman, Senator Chambliss characterized our Army in a way that I don't agree with. It doesn't matter whether a soldier is on active duty, in the active component, in the Guard, or the Reserve; there's one standard. We expect that our leadership and our soldiers adhere to the same standard, and those are Army values, the Soldier's Creed, and the things that we all believe in. So I disassociate with your remarks there that, for some reason, because this was a Reserve unit there isn't a standard that's equal to everybody else's.

Senator CHAMBLISS. General, my remarks were not directed towards this unit being a Reserve unit; they just happen to be a Reserve unit. But the fact of the matter is that the Taguba Report says that this unit, which is a Reserve unit, did not receive training during their mobilization, and that was a fault in the system, and it's a fault because they are a Reserve unit.

General SCHOOMAKER. Yes, sir. We're going to look into that. We are looking into it, and if that's true, we're going to correct it.

Senator CHAMBLISS. Thank you.

General SCHOOMAKER. Nevertheless, they have one standard.

Chairman WARNER. Thank you, gentlemen.

Senator Clinton.

Senator CLINTON. Thank you, Mr. Chairman.

I think, Mr. Secretary, that you can discern from the questions that there are still many issues that we need further clarification on. I particularly look forward to the answer that you will provide to Senator Reed's last question, following up on his line of questioning concerning the enabling of interrogation by MPs. That is something which, based on Army regulations, was not to be either done or condoned.

But, Mr. Secretary, in January 2002, when you publicly declared that hundreds of people detained by U.S. and allied forces in Afghanistan do not have any rights under the Geneva Conventions, that was taken as a signal. It is clear, in looking through the number of investigations that are currently ongoing, that it wasn't just this particular battalion, but others that did not receive appropriate training and information about their responsibilities with respect to detention or the Geneva Conventions.

The atrocities that have been depicted in photographs were very graphically described verbally in the Taguba Report. It doesn't take a lot of imagination to read those descriptions and have one's stomach just turn, in disgust.

The focus on the pictures being released is, with all due respect, missing the point. The report was well known, and apparently discussed on numerous occasions, and obviously the release of the pictures to the entire world was devastating, but the underlying conduct and the failure of the command, both at the site and further up the chain, to act with the appropriate quick response is really at the heart of what the most serious problems we face here today are.

The information in the Taguba Report links the atrocities at Abu Ghraib to Camp Bucca. In fact, some of the same people, some of the same command, some of the same MPs were apparently involved. With respect to the recommendations at the end of General Taguba's report, they call for establishing the conditions with the resources and personnel required to prevent future occurrences of detainee abuse.

I would appreciate, since we don't have time in this round of questioning, to receive, for the committee, a report about exactly how that is being handled. What changes have been made? Is the Geneva Conventions training going on now? Are the appropriate rules being posted, in both English and Arabic? Certainly we would like an explanation as to the adequacy of the punishment that was meted out, because, with respect to who is being punished for what, there is a clear distinction, at least as reported by General Taguba, between enlisted personnel and those up the command.

But I'm also concerned by a related matter. Let me just quickly reference the case of Chaplain Yee, the Muslim Army chaplain from Guantanamo Bay who was arrested and placed in solitary confinement. Ultimately, all the charges were dropped, after his reputation was sullied. It's obvious that the information about this particular case came from Government sources. It was pushed out, and it was widely disseminated. So, Mr. Secretary, how is it that

a case with no basis in fact gets such widespread publicity based on information from Government sources, while egregious conduct, like that at the Abu Ghraib prison, is cloaked in a classified report and is only made available when the investigation is leaked to the press?

Secretary RUMSFELD. Senator, first let me say, with respect to the question that Senator Reed raised, I can't conceive of anyone looking at the pictures and suggesting that anyone could have recommended, condoned, permitted, encouraged—subtly, directly, in any way—that those things take place.

Second, the decision that was made by the President of the United States, that you referred to, was announced. In the announcement, it was said that the al Qaeda in Guantanamo that were captured around the world, mostly in Afghanistan, would be treated in a manner consistent with the Geneva Conventions. That is a fact.

[Clarifying information from the DOD follows:]

The guidelines for handling al Qaeda detainees were in the President's February 7, 2002, directive, which states (in part): "As a matter of policy, the United States Armed Forces shall continue to treat detainees humanely and, to the extent appropriate and consistent with military necessity, in a manner consistent with the principles of Geneva."

Secretary RUMSFELD. You say the report was "well known." I don't know how you know that. All I know is, when it was made public, when somebody took a secret document out of prosecutorial channels and released it to the press, I do not believe it was yet anywhere in the Pentagon. Certainly I had not been given it, or seen it.

I quite agree with you. When you read the report, you do get an impression, as you suggested, that there is something much worse than what was in the press release, for example, in January, or the discussion in March by CENTCOM. But that was not something that had been moved past CENTCOM, to my knowledge. It may have been somewhere in the DOD, but certainly I had not received a copy. It was still in those channels.

Chairman WARNER. Thank you very much, Senator.

Senator Pryor.

Secretary RUMSFELD. Mr. Chairman, I'm going to have to remind you that we do have to leave at 2:30. I apologize for that. Normally I'd stay, but we're due in the House.

Chairman WARNER. That is my understanding, and we're within 6 minutes of finishing at the 2:30 deadline.

Secretary RUMSFELD. Thank you.

Chairman WARNER. Thank you very much.

Senator PRYOR. Mr. Chairman, thank you.

I'm not sure my microphone's working today, for some reason, so I'll borrow this one over here.

In Arkansas, Mr. Secretary, we have an expression that says, "You cannot unring the bell." At this point, we know where we find ourselves, and that is, these photos—and, as you indicated, there may be more to come, and even videos—are now in the public domain. We all know that they will be used to undermine U.S. credibility for years to come, and that they put our soldiers at more

jeopardy inside Iraq and other places today than they were just a few days ago.

In fact, this morning, I must tell you, I had trouble explaining the photographs and what's going on inside that prison, with my 10-year-old son. They're very hard to explain.

Mr. Secretary, let me say that there has been a pattern that I have to bring to your attention from our perspective. First, for months and months, we've asked, "Do you need more troops inside Iraq?" In the last few days, even though you've assured us many times, and many people at the Pentagon and the White House have said no, we now have learned that you do need them.

Second, we've asked, for weeks and weeks and weeks, maybe months—Senator Byrd could probably tell you more than I could about that—about whether you'll need a supplemental. Originally the answer was no, at least until very late in the year. Now it appears that you do need one.

We've been surprised on those two occasions. Now we're surprised today. Mr. Secretary, I must tell you that we do not like these types of surprises here in Congress. I don't want to sound glib in asking this question, but let me ask it anyway. We know the photographs are coming out, but do you anticipate anything else coming out in relation to this story that we need to know about today?

Secretary RUMSFELD. I'm certain there will be. You have six investigations going on. You can be absolutely certain that these investigations will discover things, as investigations do, and that they'll elevate other individuals for prosecution in criminal matters. You can be certain that there's going to be more coming out.

With respect to your other comments, the commanders on the ground, from the beginning, asked for and received all the troops they needed, all the troops they wanted, all the troops they asked for. They got them. You're right, General Abizaid called up and said, "Look, the situation in Iraq is difficult. I'd like to keep an extra 20,000 during this crossover period, and go from 115,000 to 135,000." We said yes. I went to the President, and the President said yes. The senior military advisor, General Myers, said he thought that was correct. You say you don't like surprises—my Lord, who likes surprises? Nobody in the world likes surprises. But the world's not perfect. Facts change on the ground. When facts change on the ground, commanders tell us. When commanders tell us, they get the troops they need.

Now, on the budget, you don't like surprises. Well, I don't either. It happens to be the case that more troops are needed, and more money is needed. It happens that it's a difficult thing for the military commanders to cash-flow, taking out of one account to sustain something that came up that was not anticipated. So the President said, "Fine." He did not want to ask for a supplemental. General Myers and I went in to him and said, "We think we need one. We think that that's not a good way to manage the DOD, by jerking money out of one account and sticking it in another account, trying to get preprogramming authority by Congress," and we said, "We believe that it's the appropriate thing to do." He didn't want to do it. He knew what he had said. But he said he'd do it. Now, that's not a surprise. It's just a fact.

Senator PRYOR. Mr. Chairman, thank you for your time.

Chairman WARNER. Thank you very much.

Senator DAYTON. Mr. Secretary, were you aware, or did you authorize, General Myers to call CBS to suppress their news report?

Secretary RUMSFELD. I don't have any idea if he discussed it with me. I don't think he did.

Senator DAYTON. Over the last 2 weeks, calling CBS to suppress the news report, you don't—

Secretary RUMSFELD. "Suppress" is not the right word at all. It's an inaccurate word, I should say.

Senator DAYTON. General Myers, did you discuss it with the Secretary?

General MYERS. This had been worked at lower levels by the Secretary's staff and my staff for some time, and—

Senator DAYTON. That you would call CBS to suppress their news report.

General MYERS. I called CBS to ask them to delay the pictures showing on the CBS program "60 Minutes," because I thought it would result in direct harm to our troops.

Senator DAYTON. Is that standard procedure for the military command of this country, to try to suppress a news report at the highest level?

General MYERS. Senator Dayton, this is a serious allegation.

Senator DAYTON. It sure is.

General MYERS. It is absolutely—the context of your question, I believe, is wrong.

Senator DAYTON. I understand the context, General. You told us the context earlier. I have very limited time, sir. I just want to get—

General MYERS. Well, when I—

Senator DAYTON. —this is my question.

General MYERS. I want to take as much time as we need to straighten this out. This report was already out there. The news was out there about the abuse. The thing that I—

Senator DAYTON. General, if the news had been out there and we had all known about it—

General MYERS. Right. Let me just—

Senator DAYTON. —to extent of this—

General MYERS. Senator, please, let me—

Senator DAYTON. —we would have—

General MYERS. Senator—

Senator DAYTON. —had this hearing—

General MYERS. Senator, please—

Senator DAYTON. —months ago.

General MYERS. —let me—let me finish, Senator.

Chairman WARNER. Senator, I ask that the witness be allowed to respond to your question. They're very important questions.

General, would you proceed?

General MYERS. Thank you, sir. Thank you, Senator Dayton.

This was not to suppress anything. What I asked CBS to do was to delay the release of the pictures, given the current situation in Iraq, which was as bad as it had been since major combat ended. I thought it would bring direct harm to our troops, it would kill our troops.

We talked about it, and I said, "I know this report will eventually come out, but if you can delay it for some period of time it would be helpful."

Senator DAYTON. What period of time, sir?

General MYERS. I did it based on talking to General Abizaid, and his worry was like mine, and he convinced me that this was the right thing to do. This report has been around since January. What was new were the pictures. I asked for the pictures to be delayed.

Senator DAYTON. Did you discuss calling CBS to ask them to delay their report with the Secretary of Defense or the Vice President or the President?

General MYERS. Of course not.

Senator DAYTON. None of those. All right.

General MYERS. Of course not.

Senator DAYTON. I would just say, General, that I agree with your assessment of the consequences of this on our troops. That is the great tragedy of this. But attempts to suppress news reports, to withhold the truth from Congress and from the American people, is antithetical to a democracy.

General MYERS. You bet it is, and that's not what we've been doing.

Senator DAYTON. Whatever the intentions may be, sir, the result is always the same. It is, I think, terribly tragic that the President, who wants to expand democracy around the world, by actions of his own administration is undermining that democracy in the United States. As is always the result when people try to control information, delay it, manage it, and suppress it, it has that result. It's antithetical to a democracy.

Secretary RUMSFELD. Senator, throughout the history of this country, there have been instances where military situations have existed that have led governments to talk to members of the media and make an editorial request of them that they delay, for some period, disclosing some piece of information. It is not against our history. It is not against our principles. It is not suppression of the news. It's a misunderstanding of the situation to say it is.

Senator DAYTON. It is against our principles. It's against our principles when you come before 40 to 45 Members of the Senate 3 hours before that news report is going to occur, and don't mention one word about it, sir. That is antithetical to democracy and the Constitution, which gives the Senate and the House coequal responsibility for this country.

I want to just ask about the escalation of American forces, sir. You're bringing in, in response to all of this—and, yes, this is also important—this is the future of this Nation and the people who are over there. You're increasing the number of forces, the number of tanks over there. How can this do anything but escalate the level of violence, the opposition of the Iraqis, and intensify the hatred across the Arab world to the United States and create more atrocities? How can this have any result other than to put us deeper into this situation and make the conditions there worse for our forces and for our Nation and for the world?

Chairman WARNER. Senator, I'm going to ask that the witness respond to your important question for the record, and I thank you for your cooperation.

[The information referred to follows:]

In fact, during late April/early May 2004 U.S. troop levels in Iraq were on their way down. There was a 2 week or so increase in troop levels during this period due to "overlap" as incoming forces replace troops rotating back to the United States.

Chairman WARNER. Mr. Secretary and witnesses, we've had a very thorough exchange of views. We've had a full and complete hearing. I wish to commend my colleagues. I wonder if you might indulge the Majority Leader for 1 minute.

Senator LEVIN. Mr. Chairman, could the answers for the record, which the Secretary has promised, be expedited, given the circumstances? Would that be all right?

Chairman WARNER. Yes, absolutely. That will be done.

Senator FRIST.

Senator FRIST. Thank you, Mr. Chairman.

Mr. Secretary, thank you for appearing before the Armed Services Committee today. It is important for this body, the United States Senate, to hear from you about the reprehensible incidents at Abu Ghraib prison. Needless to say, the individuals that committed these despicable acts must be held accountable. Justice must and will be served in a swift and fair and transparent matter.

We are all troubled by the fact that the actions of a few have tainted the efforts of all Americans who are serving so nobly abroad.

Mr. Secretary, I commend you for taking responsibility for what occurred at Abu Ghraib prison. If we're ever going to repair the damage done to our efforts in Iraq and to the reputation of the Armed Forces, it's important that we get all the facts out in a quick and a thorough manner.

The committees of jurisdiction here in the Senate will be conducting their own inquiries into this matter. We do look forward to regular updates from you and others on the panel and the DOD as your investigations proceed, as well as updates on any other actions you may take to ensure that justice is served and heinous acts never occur again.

Thank you.

Chairman WARNER. Thank you, Mr. Leader.

Secretary RUMSFELD. Thank you very much.

Chairman WARNER. The hearing is concluded.

[Questions for the record with answers supplied follow:]

QUESTION SUBMITTED BY SENATOR SUSAN COLLINS

RED CROSS RECOMMENDATIONS

1. Senator COLLINS. General Schoomaker, the International Committee of the Red Cross (ICRC) has said that it has had the opportunity to speak with the detainees about their treatment, and based on these discussions, it has repeatedly requested that U.S. authorities take corrective action to correct alleged abuses. The ICRC says that its recommendations were not taken seriously by the administration. Were ICRC recommendations taken seriously? If so, then how do you address these reports that many of the organization's recommendations were ignored?

General SCHOOMAKER. The ICRC visits to the detention facilities in Iraq and Afghanistan and reports generated from such visits fall under the responsibility of the U.S. Army Central Command (CENTCOM); therefore, I cannot speak to any specific allegations or incidents that fall within the CENTCOM area of responsibility (AOR). The ICRC provides their reports only to the chain of command of the detention facility that they are visiting. It is up to the commander of the detention facility to reply to the ICRC report and make corrective actions as he or she see fit; corrective ac-

tions will be conducted based on that commander's assessment of the current military situation, the availability of support, and other factors.

QUESTIONS SUBMITTED BY SENATOR CARL LEVIN

THE RYDER REPORT

2. Senator LEVIN. General Myers, according to Seymour Hersh's article in *The New Yorker* magazine, General Ryder's report of November 5, 2003, on the prison system in Iraq found "system-wide" problems relating to human rights, training, and manpower issues. General Ryder reportedly recommended that procedures be established to "define the role of military police soldiers . . . clearly separating the actions of the guards from those of the military intelligence personnel." General Taguba is reported to find that "many of the systemic problems that surfaced during [Ryder's] assessment are the very same issues that are the subject of this investigation." Since the release of General Ryder's report on November 5, 2003, has the Army implemented General Ryder's recommendation to establish procedures separating the role of military police (MPs) from that of military intelligence personnel?

General MYERS. Major General Ryder conducted an assessment of detention and correction operations in Iraq and provided recommendations to CJTF-7 to improve those operations. The specific recommendation referred to above was to, "Determine the scope of intelligence collection that will occur at Camp Vigilant. Refurbish the Northeast compound to separate the screening operation from the Iraqi-run Baghdad Correctional Facility. Establish procedures that define the role of military police soldiers securing the compound, clearly separating the actions of the guards from those of the military intelligence personnel." CJTF-7 did take action on this recommendation concerning force protection responsibilities of military police soldiers securing the compound.

Further, CJTF-7, under Major General Miller's supervision, has defined the proper roles for military police and military intelligence personnel, and has ensured that they understand their respective responsibilities. The roles of the military police and military intelligence complement one another. The military police are responsible for custody and detainee control; the military intelligence has screening and interrogation responsibilities. Military police can assist the military intelligence by observing detainees and reporting on their associations and activities.

CJTF-7 initiated numerous additional improvements to detention operations based on Major General Ryder's recommendations. These included strict control of weapons in detention facilities, centralized planning for interrogation priorities, separation of high value detainees, augmentation of staffs with subject matter experts, employment of a detention mobile training team, certification of personnel on critical detention tasks, and multiple projects to improve living conditions for detainees and soldiers. Improved medical care, use of the Biometric Assessment Tool (BAT), and a review of theater release procedures also resulted from CJTF-7 action on Major General Ryder's recommendations.

3. Senator LEVIN. General Myers, will General Miller, who is in charge of detention operations in Iraq, take steps to ensure that the role of MP soldiers is defined and clearly separate from the role of military intelligence personnel at detention facilities?

General MYERS. Major General Miller has taken steps to ensure that both military police and military intelligence personnel understand their respective roles. Military police can assist military intelligence personnel by observing detainees and reporting on their activities and associations. This "passive" involvement of the military police is what MG Miller has advocated.

TAGUBA REPORT RECOMMENDATIONS

4. Senator LEVIN. General Smith, General Taguba's report contained a number of recommendations resulting from his investigation. To what extent have the recommendations contained in the Taguba Report been adopted and implemented? Please address each of the specific recommendations in the three parts of the report.

General SMITH. The attached summary of MNF-I actions taken after the reports is responsive to this question.

JTF-GTMO SME GROUP

RECOMMENDATION

ESTABLISH COORDINATING AUTHORITY TO DIRECT AND COORDINATE ALL HUMINT COLLECTION AND ANALYSIS IN IRAQ. CJ2X REQUIRES ADDITIONAL MANNING TO MEET NEED.

ESTABLISH A CLEAR METHOD OF PRIORITIZATION OF COLLECTION REQUIREMENTS. TOO MANY PRIORITIES TO FOCUS HUMINT EFFORTS ON.

MUST DRAFT AND RECEIVE APPROVAL FOR THEATER WIDE INTERROGATION AUTHORITIES, POLICIES AND PRACTICES TO OUTLINE THE PROCESS, INTERROGATION AND EXPLOITATION OF DETAINEES

ESTABLISH A HUMINT COLLECTION AND TARGETING MEETING TO PROVIDE FOR INFORMATION SHARING, INTERNEE ACCESS AND TASKING PROTOCOLS (TO INCLUDE SOF, CTF, OGA, CTF AND ISG) TO SUPPORT COMMNF-I OBJECTIVES

MNF-I STATUS

MNF-I ASSUMED RESPONSIBILITIES FOR ALL HUMINT COLLECTION AND ANALYSIS AND RECEIVED ADDITIONAL MANNING AS REQUIRED BY COMMNF-I

MNF-I CJ2X REDUCED THE NUMBER OF PRIORITY HUMINT REQUIREMENTS TO THOSE NECESSARY TO MEET COMMNF-I'S INFORMATION NEEDS

MNF-I DRAFTED AND PUBLISHED A DOCUMENT WHICH OUTLINED INTERROGATION AUTHORIZATIONS TO BE UTILIZED WITHIN THE THEATER

AN WEEKLY INTERSERVICE/ AGENCY TARGETING BOARD HAS BEEN IMPLEMENTED TO FOCUS EFFORTS WITHIN THE THEATER.

JTF-GTMO SME GROUP 2 RECOMMENDATION

MNF-I STATUS

EXPEDITE EXCHANGE OF CT INFORMATION BETWEEN COLLECTORS AND NATIONAL INTEL COMMUNITY THROUGH THE INTEGRATION WITH JTF-CT

JTF-CT REPRESENTATIVES NOW IN PLACE AT PRIMARY THEATER INTERROGATION FACILITIES

ESTABLISH AND TRAIN TIGER TEAMS COMPRISED OF INTERROGATOR AND ANALYST.

5 GITMO TEAMS ATTENDED TIGER TEAM UNIVERSITY AT FORT HUACHUCA PRIOR TO DEPLOYMENT. MNF-I HAS 20 TIGER TEAMS AT READINESS LEVELS 1 & 2. SIX TIGER TEAMS HAVE GRADUATED AND THREE MORE AVAILABLE SEVEN DAYS AFTER INITIAL TRAINING

CONSOLIDATE THE INTERROGATION MISSION AND ONE JIDC/INTERROGATION FACILITY UNDER MNF-I COMMAND

DCG-DETAINEE OPS NOW THE SINGLE POINT FOR INTERROGATIONS. FINAL SYNCHRONIZATION COMPLETED 15MAY04

DEDICATE AND TRAIN A DETENTION GUARD FORCE SUBORDINATE TO THE JIDC COMMANDER THAT SETS THE CONDITIONS FOR SUCCESSFUL INTERROGATION AND EXPLOITATION

MP'S WERE NOT TASK ORGANIZED UNDER THE JIDC COMMANDER. MP'S ARE NOW TACON TO DCG-DETAINEE OPERATIONS FOR THE DETENTION AND PASSIVE INTERROGATION SUPPORT MISSIONS

TRAIN ANALYSTS TO INCORPORATE DATABASES INCLUDING DIMS, CT-LINK, WEB SAFE, HARMONY AND COLISEUM IN INTERROGATION PLANNING AND EXECUTION

INFORMATION MANAGEMENT SYSTEMS (IDC) TO FACILITATE ANALYST EFFORTS, TO INCLUDE IDC, ARE BEING UTILIZED. COLOCATION OF IDC TERMINALS AT ABU GHARAIB BY 01 SEP 04



JTF-GTMO SME GROUP 3 RECOMMENDATION

MNF-I STATUS

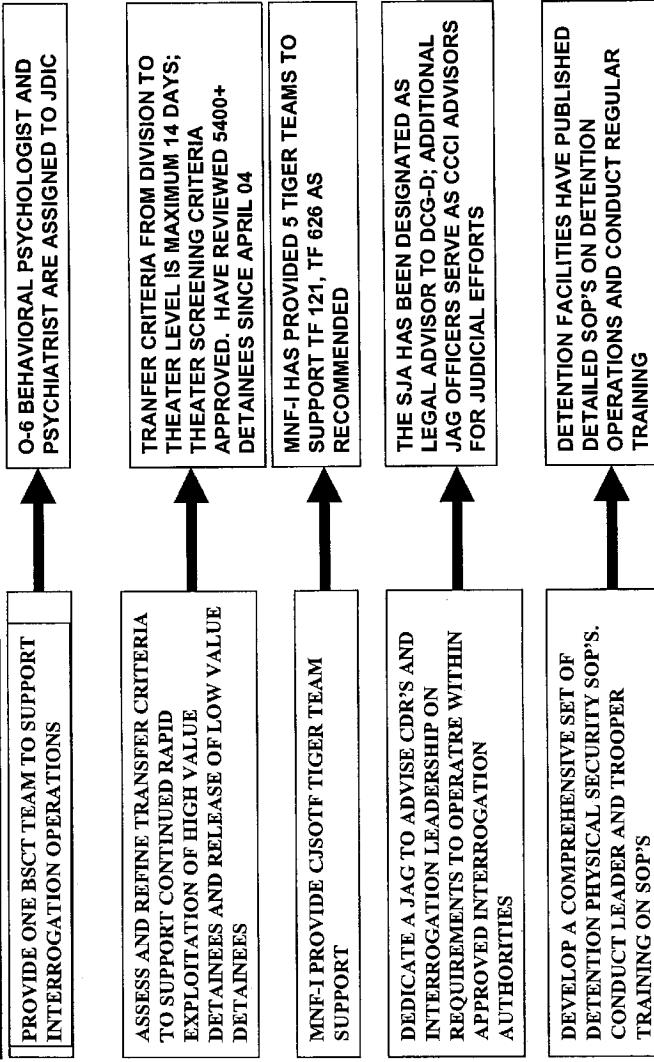

JTF-GTMO SME GROUP 4 RECOMMENDATION

MNF-I STATUS

CONDUCT SCENARIO BASED TRAINING TO ENSURE SOP'S ARE KNOWN AND APPLICATION THOROUGHLY UNDERSTOOD BY DETENTION PERSONNEL

SCENARIO BASED TRAINING IS CONDUCTED AT EVERY GUARD MOUNT RULES FOR THE USE OF FORCE IN DETENTION CENTER IS WEEKLY FOCUS

ASSIGN, TRAIN AND SUSTAIN INTERROGATOR AND DETENTION STAFF TEAM BUILDING FOCUSED ON IMPROVING THE COLLECTION OF INTELLIGENCE

TIGER TEAMS AND DETENTION PERSONNEL EXCHANGE INFORMATION BASED ON THE PASSIVE INFORMATION COLLECTION AND OBSERVATIONS OF DETAINEES BY MP'S

DEVELOP OPERATING PROCEDURES FOR IMPLEMENTING DISCIPLINARY MEASURES RELATED TO DETAINEE OPERATIONS

CDR, 16TH MP BDE HAS DEVELOPED INCENTIVES PROGRAM FOR MNF-I DETENTION EFFORT. IT HAS BEEN APPROVED AND IN USE

SEGREGATE MALES, FEMALES AND JUVENILE INTERNEES TO PREVENT UNAUTHORIZED CONTACT

MALES, FEMALES AND JUVENILES HAVE BEEN SEGREGATED WITHIN DETENTION FACILITIES. NO CONTACT EXISTS.

CREATE AN AUTOMATED KNOWLEDGE CENTER INCORPORATING INFORMATION AND DOCUMENTS CURRENTLY LOCATED IN DIVERSE DATA STORES

AUTOMATED KNOWLEDGE CENTER HAS BEEN ESTABLISHED AND WORKING AT MNF-I C.J2X. ABU GHARAIB FACILITY WILL BE UPDATED BY 01JUN04

15-6 INVESTIGATION OF 800TH MP BDE

RECOMMENDATION

IMMEDIATELY DEPLOY AN INTEGRATED MULTI DISCIPLINE MITT COMPRISED OF SME'S IN INTERNMENT OPS, INTERNATIONAL AND OPERATIONAL LAW, FACILITY MANAGEMENT, INTERROGATION AND INTELLIGENCE GATHERING TECHNIQUES, CHAPLAINS ARAB CULTURAL AWARENESS AND MEDICAL PRACTICES

SME'S HAVE CONDUCTED MULTIPLE MITT'S TO ASSIST IN TRAINING MP'S AND GTMO TIGER TEAMS TO IMPROVE INDIVIDUAL AND UNIT KNOWLEDGE IN IDENTIFIED AREAS. MEDICAL PRACTICES MITT COMPLETED. CPA HAS ALSO PROVIDED SME ASSISTANCE IN AREAS OF ARAB CULTURAL AWARENESS

ALL PERSONNEL INVOLVED IN DETENTION OPERATIONS RECEIVE TRAINING ON THE LAW OF LAND WARFARE

TRAINING ON THE LAW OF LAND WARFARE IS CONDUCTED AT ROUTINELY AS PART OF ANNUAL 350-1 TRAINING. LEADER CONTINUE TO REENFORCE TENETS. RULES FOR USE OF FORCE IN DETENTION CENTERS UPDATED IN APR04

A SINGLE COMMANDER IN MNF-I BE RESPONSIBLE FOR OVERALL DETAINEE OPERATIONS THROUGHOUT IRAQ THEATER OF OPERATIONS

MG MILLER HAS BEEN DESIGNATED AS THE SINGLE POINT OF CONTACT FOR ALL DETENTION AND INTERROGATION OPERATIONS IN MNF-I

CDR'S ENSURE COPIES OF THE GENEVA CONVENTION RELATIVE TO THE TREATMENT OF PRISONERS OR WAR BE MADE AVAILABLE IN ALL CAMPS IN BOTH ENGLISH AND DETAINEE LANGUAGE

DETENTION FACILITIES HAVE POSTED GENEVA CONVENTION RULES FOR TREATMENT OF EPW AND DETAINEES IN ENGLISH AND DETAINEE LANGUAGES

15-6 INVESTIGATION OF 800TH MP BDE 1 MNF-I STATUS

THAT EACH DETENTION FACILITY COMMANDER AND INTERROGATION FACILITY COMMANDER PUBLISH A COMPLETE AND COMPREHENSIVE SET OF STANDING OPERATING PROCEDURES REGARDING TREATMENT OF DETAINEES, AND THAT ALL PERSONNEL BE REQUIRED TO READ THE STANDING OPERATING PROCEDURES AND SIGN A DOCUMENT INDICATING THAT THEY HAVE READ AND UNDERSTAND THE STANDING OPERATING PROCEDURES.

THAT ALL UNITS IN THE IRAQ THEATER OF OPERATIONS CONDUCTING INTERNMENT/CONFINEMENT/DETAINMENT OPERATIONS IN SUPPORT OF OPERATION IRAQI FREEDOM BE UNDER OPERATIONAL CONTROL FOR ALL PURPOSES, TO INCLUDE ACTION UNDER THE UNIFORM CODE MILITARY JUSTICE, TO MNF-I.

THAT AN INQUIRY ARMY REGULATION 381-10, US ARMY INTELLIGENCE ACTIVITIES, PROCEDURE 15 BE CONDUCTED TO DETERMINE THE EXTENT OF CULPABILITY OF MILITARY INTELLIGENCE PERSONNEL, ASSIGNED TO THE 205TH MILITARY INTELLIGENCE BRIGADE AND THE JOINT INTERROGATION AND DEBRIEFING CENTER REGARDING ABUSE OF DETAINEES AT ABU GHRAIB.

A COMPREHENSIVE SOP HAS BEEN PUBLISHED WITH COVERS THE HANDLING AND TREATMENT OF DETAINEES FOR ALL THEATER DETENTION FACILITIES. DCG-D REVIEW OF SOP'S COMPLETED 15MAY04.

ALL UNITS INVOLVED IN INTERNMENT /CONFINEMENT/DETAINMENT ARE TASK ORGANIZED UNDER MNF-I

INVESTIGATION BY GENERAL KERN AND MG FAY IS CURRENTLY ONGOING

15-6 INVESTIGATION OF 800TH MP BDE 2

RECOMMENDATION

ACCOUNTABILITY PRACTICES THROUGHOUT ANY PARTICULAR DETENTION FACILITY MUST BE STANDARDIZED AND IN ACCORDANCE WITH APPLICABLE REGULATIONS AND INTERNATIONAL LAW.

THE NATIONAL DETAINEE REPORTING SYSTEM (NDRS) AND BIOMETRIC AUTOMATED TOOL SET SYSTEM (BATS) ACCOUNTING SYSTEMS MUST BE EXPANDED AND USED TO THEIR FULLEST EXTENT TO FACILITATE REAL TIME UPDATING WHEN DETAINEES ARE MOVED AND OR TRANSFERRED FROM ONE LOCATION TO ANOTHER

STANDING OPERATING PROCEDURES MUST BE WRITTEN, DISSEMINATED, TRAINED ON, AND UNDERSTOOD AT THE LOWEST LEVEL

ACCOUNTABILITY LAFSES, ESCAPES, AND DISTURBANCES WITHIN THE DETAINMENT FACILITIES MUST BE IMMEDIATELY REPORTED THROUGH BOTH THE OPERATIONAL AND ADMINISTRATIVE CHAIN OF COMMAND VIA A SERIOUS INCIDENT REPORT.

MNF-I STATUS

ALL ACCOUNTABILITY PRACTICES WITHIN SEPARATE DETENTION FACILITIES ARE STANDARDIZED AND DOCUMENTED. FINAL REVIEW BY DCG-D COMPLETED MAY04

BATS AND/OR BATS PLUS ARE DISTRIBUTED TO DIVISION LEVEL. ALL DETAINEES ARE TRANSFERRED WITH EXISTING BATS FILES. NDRS HAS BEEN FIELDIED AND IN USE ACROSS MNF-I. BATS SYSTEM CONTRACTOR IN THEATER PROVIDING SOFTWARE UPGRADES TO UNITS. COMPLETION DATE 18 AUG 04.

SOPs ON DETENTION, INTERROGATION AND THE ADMINISTRATION OF DETENTION FACILITIES HAVE BEEN REVIEWED AND PUBLISHED TO THE LOWEST LEVEL

ALL ESCAPES AND DISTURBANCES ARE REPORTED AS PART OF PUBLISHED CCIR TO THE DCG-D AND COMMNF-I.

15-6 INVESTIGATION OF 800TH MP BDE 3

RECOMMENDATION

DETENTION RULES OF ENGAGEMENT AND INTERROGATION RULES OF ENGAGEMENT, AND THE PRINCIPLES OF THE GENEVA CONVENTIONS NEED TO BE BRIEFED AT EVERY SHIFT CHANGE AND GUARD MOUNT

MNF-I STATUS
DETENTION ROE/RUF AND PRINCIPLES OF GENEVA CONVENTION ARE ROUTINELY BRIEFED AT SHIFT CHANGE AND GUARD MOUNTS.

AFTER ACTION REPORTS MUST BE CONDUCTED AFTER SERIOUS INCIDENTS AT ANY GIVEN FACILITY.

AAR'S OF ALL SERIOUS INCIDENTS ARE CAPTURED BY UNIT LESSON LEARNED CELLS AND REVIEWED FOR FUTURE EFFORTS

THERE MUST BE SIGNIFICANT STRUCTURAL IMPROVEMENTS AT EACH OF THE DETENTION FACILITIES.

SIGNIFICANT UPGRADES OF FACILITIES OF ALL DETENTION CAMPS HAVE OCCURRED OVER THE LAST FOUR MONTHS TO INCLUDE FORCE PROTECTION FOR DETAINEES AT ABU GHARAIB, BUCCA AND CAMP CROPPER. CAMP REDEMPTION LOCATED AT ABU GHARAIB WILL PROVIDE IMPROVED SUPPORT AND SUSTAINMENT TO DETAINEES OPENED IN JUNE 04.

THE GENEVA CONVENTIONS AND THE FACILITY RULES MUST BE PROMINENTLY DISPLAYED IN ENGLISH AND THE LANGUAGE OF THE DETAINEES AT EACH COMPOUND AND ENCAMPMENT AT EVERY DETENTION FACILITY IN ACCORDANCE WITH ARMY REGULATION 190-8, ENEMY PRISONERS OF WAR, RETAINED PERSONNEL, CIVILIAN INTERNEES AND OTHER DETAINEES.

IMPLEMENTED IN ALL CAMPS IN ENGLISH AND DETAINEE LANGUAGE

15-6 INVESTIGATION OF 800TH MP BDE 4

RECOMMENDATION

THOSE MILITARY UNITS CONDUCTING INTERNMENT/RESETTLEMENT OPERATIONS MUST KNOW OF, TRAIN ON, AND CONSTANTLY REFERENCE THE APPLICABLE ARMY DOCTRINE AND CJTF COMMAND POLICES.

MNF-I STATUS

ALL COMMAND POLICES ARE BRIEF AND POSTED IN UNIT AREAS. ROUTINE TRAINING IS CONDUCTED AT GUARD MOUNT ON DAILY DETENTION TASKS AND STANDARDS

PMG

RECOMMENDATION

ENCOURAGE JOINT CPA/MNF-I CENTRALIZED PLANNING WITH DECENTRALIZED EXECUTION; TAKE ADVANTAGE OF CURRENT MILITARY STRUCTURE TILL OIF 2.

CONSOLIDATE SECURITY INTERNEES AT ABU GHRAIB (W/ SEPARATE HIGH VALUE DETAINEE SITE); CONSOLIDATE IRAQI PRISON OPERATIONS AT LARGE REGIONAL FACILITIES

REMOVE ALL WEAPONS FROM THE INTERIOR AND PROXIMITY OF FACILITIES; APPLY GREATER DISCIPLINE TO KEY/TOOL ACCOUNTABILITY; CONDUCT USD/RULES OF ENGAGEMENT TRAINING

AUGMENT TRANSITION TO OIF 2 FORCES WITH ACTIVE COMPONENT 95C/31E NCOS (MSG, 3 SECS) AT ABU GHRAIB AND ONE SQUAD AT THE HIGH VALUE DETAINEE FACILITY

MNF-I STATUS

PLANNING FOR INTERROGATION PRIORITIES IS CENTRALIZED WITH CJ2X AND ISG WITH INTERROGATION FACILITIES EXECUTING INTERROGATIONS

HIGH VALUE DETAINEES AND CCCI CANDIDATES ARE CONSOLIDATED AT ABU GHARAIB FOR INTERROGATION AND DETENTION. DETAINEES OF LOW VALUE ARE BEING TRANSFERRED TO THE CAMP BUCCA

WEAPONS IN DETENTION FACILITIES ARE STRICTLY CONTROLLED. DETENTION PERSONNEL AND INTERROGATION PERSONNEL ARE PROHIBITED FROM MAINTAINING ANY ADDITIONAL WEAPONS WHEN WORKING WITH OR NEAR DETAINEES.

31E SME ARE ASSIGNED AS SUPERINTENDENTS AT ABU GHRAIB (2) and CAMP BUCCA (3). BDE'S ARE PRESENT AT ALL DETENTION FACILITIES TO CONDUCT QA AND REMEDIAL/REFRESHER TRAINING AS REQUIRED. DETENTION MTT COMPLETED 31E TRAINING AND CERTIFICATION WITH ALL DETENTION PERSONNEL 28 JUNE 04.

PMG 1

RECOMMENDATION

ASSIGN TWO MILITARY POLICE (INTERMENT/RESETTLEMENT) BATTALIONS TO A MILITARY POLICE COMBAT SUPPORT BRIGADE TO CONDUCT SECURITY INTERNEE MISSION AT ABU GHRAIB AND HIGH VALUE DETAINEE SITE; AUGMENT STAFF

MNF-I STATUS

IMPLEMENTED WITH ONE I/R BN AT ABU GHARAIB. ALL OTHERS ARE COMBAT SUPPORT MP BN'S. DETENTION MTT IS CERTIFYING ALL NON-31E'S. CORRECTIONS MP'S ON CRITICAL DETENTION TASKS

OPCON ONE MILITARY POLICE (INTERMENT/RESETTLEMENT) BATTALIONS TO BCT SECURING MEK COMPOUND.

MP COMBAT SUPPORT BATTALION SECURING MEK COMPOUND. PERSONNEL RECEIVING 31E MTT TRAINING AND CERTIFICATION

AUGMENT DIVISION PROVOST MARSHALS WITH CORRECTIONS EXPERTS (MILITARY POLICE CPT, 2 95C NCO'S).

DIVISIONS MAINTAIN DETENTION NCO'S IN PMO. SME PROVIDING OVERSIGHT TO DIVISION AND BRIGADE DETENTION FACILITIES

CONTINUE RENOVATION PROJECTS OF FACILITY LATRINES/SHOWERS; USE DETAINEE LABOR TO MAINTAIN SANITATION STANDARDS

PROJECTS TO IMPROVE THE LIVING CONDITION OF DETAINEES AND SOLDIERS OVER THE LAST FOUR MONTHS HAVE GREATLY IMPROVED THE STANDARD OF LIVING FOR ALL PERSONNEL; DETAINEES ARE USED TO MAINTAIN SANITATION OF DETAINEE HOLDING AREAS

PMG 2

RECOMMENDATION

THE BAGHDAD CENTRAL CORRECTIONAL FACILITY (ABU GHARAIB) SHOULD BE EQUIPPED TO MANAGE THE CHRONICALLY ILL AND SPECIAL NEEDS DETAINEES

LEVEL II MEDICAL FACILITY IS OPERATING AT BCCF TO PROVIDE APPROPRIATE MEDICAL CARE. SPECIAL CARE NEEDS CAPABILITY IS PROVIDED TO DETAINEES ON LOCATION OR SPECIALIST MOVED TO DETENTION FACILITY. SPECIAL CASE DETAINEES ARE MAINTAINED SEPARATE FROM THE GENERAL DETAINEE POPULATION: PHYSICALLY AND MENTALLY ILL, FEMALE, JUVENILES

REVIEW RELEASE POLICY IAW DODD 2310.1; VET POLICY THRU USA

THEATER RELEASE POLICY ESTABLISHED AND COORDINATED WITH ALL AGENCIES. RELEASE POLICY IAW DODD 2310.1; VET POLICY THRU USD

ADOPT 4TH ID DETAINEE DISPOSITION WORKSHEET AND A DETAINEE INQUIRY RESPONSE FORM ACROSS THE AREA OF OPERATIONS

BATS/BATS PLUS PROVIDE THE THEATER STANDARD ON DOCUMENTS IN THE MANAGEMENT AND TRANSFERRING OF ALL DETAINEES

PREPARE FOR MILITARY COMMISSIONS TO TRY PERSONS IN IRAQ ACCUSED OF CRIMES AGAINST US FORCES

HIGH VALUE DETAINEES WILL BE REFERRED TO IST. DETAINEES WHO HAVE COMMITTED CRIMES AGAINST THE COALITION ARE REFERRED TO THE CENTRAL CRIMINAL COURT OF IRAQ FOR PROSECUTION UNDER IRAQI LAW. DETAINEES WHO COMMIT IRAQI ON IRAQI CIVIL CRIMES ARE REFERRED TO CRIMINAL COURT OF IRAQ

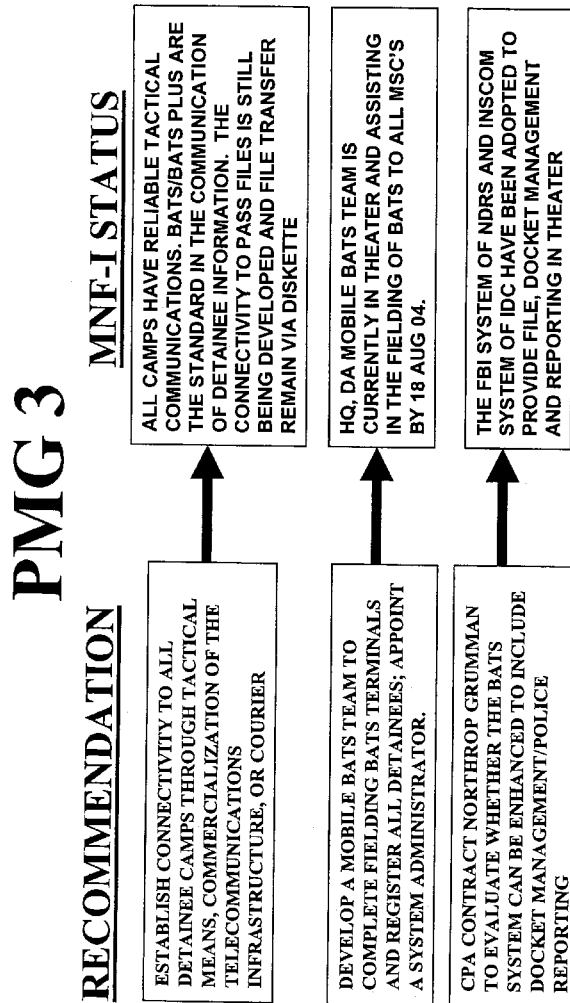

RED CROSS VISITS TO ABU GHRAIB

5. Senator LEVIN. General Myers and General Smith, the ICRC report of February 2004 states that the ICRC was aware of abuses at Abu Ghraib prison for months prior to the period covered by General Taguba's investigation and had repeatedly asked U.S. authorities to take corrective action. What was the extent of the ICRC's access to the facilities at Abu Ghraib? Did it include the part of the facility where the abuses depicted in the photos are alleged to have occurred?

General MYERS and General SMITH. The ICRC Summary Report of February 2004 refers to an ICRC visit to the Abu Ghraib Correctional Facility conducted in October 2003, during the same period that many of the alleged abuses occurred. A written report related to the October 2003 visit was provided to CJTF-7 Staff Judge Advocate's office in November 2003. Both ICRC reports provide indications of detainee abuse, however, not to the extent depicted in the photographs. The CJTF-7 Staff Judge Advocate Office circulated the November report among relevant commands and staffs, proposed a draft response and, following discussions and meetings with leadership of the military intelligence and military police units involved, forwarded

the draft document to the 800th Military Police BDE. A written response to the ICRC was signed by the Commander, 800th Military Police Brigade in December 2003 and delivered to the ICRC. A staff action plan was implemented for the next ICRC visit to Abu Ghraib in January 2004. During the October visit to Abu Ghraib and in subsequent visits, ICRC representatives did have access to the part of the prison where the abuses are alleged to have occurred.

6. Senator LEVIN. General Myers and General Smith, what specific steps were taken to correct the situation at Abu Ghraib in response to these ICRC requests?

General MYERS and General SMITH. The longstanding arrangement between the ICRC and the Department of Defense is that issues are discussed and resolved at the local level or at the lowest practicable level of command. At Abu Ghraib, the lowest practicable level of command would have been the 800 Military Police Brigade and 205 Military Intelligence Brigade, overseen by CJTF-7. Following receipt of the November ICRC report, a staff action plan was developed. Improvements in detention conditions were made by the commands following the October 2003 visit as noted by the ICRC in a subsequent visit in January 2004. Since January 2004, the Department of Defense has initiated numerous investigations regarding the treatment of detainees and instituted changes at every level to ensure improved conditions of detention facilities and appropriate treatment of detainees.

Included in these initiatives are significant organizational and policy changes. The Office of the Secretary of Defense has established an office, the Deputy Assistant Secretary of Defense for Detainee Affairs, which focuses on worldwide detainee operations. The Joint Staff has also expanded staff organizational responsibilities. As a result of a policy change, reports from the ICRC are forwarded expeditiously by commands to the Department of Defense, reviewed by these staffs and significant issues are brought to the attention of the leadership.

7. Senator LEVIN. General Myers and General Smith, there are reports of "ghost detainees" who were moved around within the facility in order to conceal them from ICRC inspection teams. Have you investigated these reports, and if so, what were your findings?

General MYERS and General SMITH. The allegations were investigated and other investigations are ongoing. Apparently there existed a practice in the fall of 2003 of allowing Other Government Agencies (OGA) to drop off detainees for up to a 72-hour hold without being processed and issued Internee Security Numbers (ISN) in accordance with Army and CJTF-7 procedures. CJTF-7 learned of this practice in early January 2004 and stopped it.

In other instances, the OGA detainees were in-processed and registered with the ICRC. Reports received indicate that ICRC representatives observed these detainees in cells marked with their Geneva Conventions status. The ICRC was not allowed to meet with certain detainees during visits because they were being interrogated. Under provisions of the Geneva Conventions, detainees may be held for a reasonable period of time without registering them with the ICRC for military necessity. This may include the time required to process detainees from point of capture to a detention facility.

All detainees currently in the custody of the Department of Defense have been registered with the ICRC.

8. Senator LEVIN. General Myers and General Smith, the ICRC told the Department of Defense (DOD) of the alleged abuses at Abu Ghraib months before a U.S. soldier notified his superiors in January of this year. What steps were taken to investigate, verify, address, or stop the abuses detailed by the ICRC?

General MYERS and General SMITH. An ICRC visit to the Abu Ghraib Correctional Facility was conducted in October 2003. A written report related to the October 2003 visit was provided to the CJTF-7 Staff Judge Advocate's office in November 2003. This ICRC report provided indications of detainee abuse, however, not to the extent depicted in the photographs. CJTF-7, the 800th Military Police Brigade and the 205th Military Intelligence Brigade staffed the report locally. Corrective actions were taken as noted by the ICRC during the January 2004 visit. I am not aware of any other reporting of ICRC findings to Department of Defense officials. To ensure visibility above the local level, the Department of Defense has implemented a policy that requires ICRC reports to be forwarded higher.

9. Senator LEVIN. General Myers and General Smith, other than Brigadier General Karpinski, was anyone else within DOD, the Coalition Provisional Authority (CPA), or other Federal agencies briefed about the abuses, detailed by the ICRC, at Abu Ghraib? Who were they and when were they briefed?

General MYERS and General SMITH. The November 2003 ICRC report gave indications of detainee abuse at Abu Ghraib, but not to the level of abuse later revealed in the photographs. General Abizaid notified me on 13 January 2003 of the allegations of abuse at Abu Ghraib reported by a soldier in the 372d Military Police Company. I don't recall an ICRC report being mentioned during that conversation. I am not aware of briefings concerning the November ICRC report being conducted within the Department of Defense or any other Federal agency until after the investigation into the alleged abuses was opened in January.

10. Senator LEVIN. General Myers and General Smith, which senior administration officials have received the reports by the ICRC detailing abusive behavior at U.S. detention facilities in Iraq? When did they receive such reports? What actions were taken in response to such reports?

General MYERS and General SMITH. I personally was not provided copies or summaries of any ICRC reports detailing abusive behavior at U.S. detention facilities in Iraq. The ICRC generally provides working papers, reports, and observations to the lowest level organization that the ICRC believes can resolve the issues. In Iraq, the ICRC reports were provided to the detention facility visited, to the CJTF-7 staff, or in at least one instance to the CPA. The ICRC does not provide reports to the Joint Staff. The ICRC may on occasion provide information to the Department of State or to the Office of the Secretary of Defense (OSD). I am not aware of any senior officials in OSD, or in any other Federal agency, who may have received ICRC reports detailing abusive behavior at U.S. detention facilities in Iraq.

INFORMATION FLOW

11. Senator LEVIN. General Myers, USA Today reports that on January 13, 2004, General Abizaid made a phone call to you in which he "described the allegation of mistreatment" and told you about the pictures, saying 'here's what basically the pictures might show.' Is this an accurate accounting of this conversation?

General MYERS. Yes, it is accurate. The CENTCOM chain of command immediately recognized the significance of the allegations of abuse at Abu Ghraib. Determined to take proper action, a criminal investigation was immediately initiated and the matter was reported to the chain of command. General Abizaid contacted me telephonically and informed me that a soldier had reported the abuse. As I recall, he also informed me that the soldier provided photos of abusive acts that were significant, although I do not believe the acts depicted in the photos were precisely described. General Abizaid further informed me that the Criminal Investigation Division (CID) was investigating the report and that LTG Sanchez would direct a separate investigation into the matter.

12. Senator LEVIN. General Myers, at the hearing you said that you had meetings starting in January 2004, including with Secretary Rumsfeld, in which you discussed the detainee abuse situation at Abu Ghraib, and that you understood at that time the potential damage of the problem, and of photos you were aware of. Please provide the dates of the meetings you had at which you discussed this detainee abuse problem, and whether you discussed the photos and the potential for this issue to cause damage. When did you plan on informing the relevant congressional committees about this matter?

General MYERS. In January 2004, General Abizaid informed me of the allegations of abuse and the nature of the photographs. Subsequently, various meetings were held with the Secretary of Defense in January, February, and March, and a meeting with the President, Secretary Rumsfeld, and Vice Chairman Pace was held in mid-April. The abuse issue was one of many topics mentioned at these meetings. While we were advised of the allegations, we had not seen the photos. We were aware that reports of detainee abuse could potentially affect the world's opinion of the United States and impact our forces in Iraq, especially at a time when former regime elements had increased the tempo of their attacks. We were also aware that public discussion of the investigations into these allegations by senior leaders could be interpreted as direction or pressure for a certain outcome in these cases. It was our intent to provide information to the relevant congressional committees about this matter once the investigations were complete, the chain of command had the opportunity to make decisions, and we had sufficient information to release to the committees. This plan was preempted by unauthorized release of the photographs and Major General Taguba's report. As I stated in my 7 May testimony, we could have done a better job of informing Congress of the situation and the existence of the photographs.

NUMBER OF INVESTIGATIONS

13. Senator LEVIN. Secretary Rumsfeld, during the week of May 3, General Casey, the Army Vice Chief of Staff, said that there were some 35 investigations under way relating to detainee abuses or deaths or similar allegations. On May 11, General Romig testified that the Army was tracking some 83 different detainee abuse cases in Iraq and Afghanistan. As of today, how many cases of abuses have been reported and how many investigations have been initiated? How many relate to abuse, and how many relate to deaths?

Secretary RUMSFELD. As of 7 May, a total of 56 cases of abuse had been reported and were being investigated. Of these 56 cases, 33 involve allegations of abuse and 23 involve deaths. These numbers will almost certainly change as more information becomes available and we will continue to brief the committee as additional findings arise.

14. Senator LEVIN. Secretary Rumsfeld, how many people are under investigation in these cases? Is it more than the ones identified in the Taguba Report?

Secretary RUMSFELD. As of 7 May, a total of 122 people were under investigation in the 56 detainee abuse and death investigations. It is believed this number exceeds the number of individuals identified in the Taguba Report.

15. Senator LEVIN. Secretary Rumsfeld, given the apparently large number of investigations, and based on the Taguba Report, this appears to be a systemic problem. Do you agree?

Secretary RUMSFELD. The Department of the Army Inspector General, after completing his inspection of detainee operations, concluded that the abuse of detainees does not appear to be a systemic problem. This conclusion was shared by the Schlesinger Panel, which noted that there was no "policy of abuse" at Abu Ghraib. This conclusion is also consistent with the findings of the Fay Report. We have other investigations in progress and will continue to brief the committee on additional findings.

CLASSIFICATION OF THE TAGUBA REPORT

16. Senator LEVIN. Secretary Rumsfeld, the DOD has classified the Taguba Report. I have concerns about how this process was conducted. Why is the section detailing abuses classified while the names of the alleged perpetrators were not?

Secretary RUMSFELD. In preparing his report, I am advised that General Taguba relied upon material marked classified as sources of information. Under established classification guidance, General Taguba was required to carry that classification forward on all statements in his report that were derived from this source material. Additionally, his entire report is required to be marked at the highest classification level of any material in it. Consequently, while most portions of General Taguba's report were marked unclassified, the entire report was marked Secret NOFORN. We have, however, released large portions of that report and the several others that followed.

17. Senator LEVIN. Secretary Rumsfeld, Section 1.7 of Executive Order 12958 states: "In no case shall information be classified in order to . . . conceal violations of law [or to] prevent embarrassment to a person, organization, or agency." What was the justification for classifying some of the report and not the portions naming the alleged perpetrators? Who was involved in the classification process and how was their decision reached? Do you believe that it was appropriate given the nature and content of the report?

Secretary RUMSFELD. See answer above.

READING OF THE TAGUBA REPORT

18. Senator LEVIN. General Myers, you testified that you had discussed the prisoner abuse issue with Secretary Rumsfeld in January. You called CBS in early April to request that they delay broadcast of the photos showing the abuse, which they did. Yet a week after CBS had broadcast the photos, you had still not read the Taguba Report, even though it had been completed in March. Given that you knew of the abuse problem in January, and you knew in early April that release of the photos could cause serious problems, why did you not read the Taguba Report as soon as it was completed?

General MYERS. While Major General Taguba completed his investigation on 12 March, required chain of command actions were not complete until the end of April. The appointing authority reviewed Major General Taguba's findings and recommendations and recommended appropriate actions on 6 April. In accordance with required procedures, adverse actions were referred to the individuals involved, providing them an opportunity to respond. The chain of command took final action on 30 April. The final report was not received in Washington, DC, until shortly thereafter, well after my conversation with CBS and after the unauthorized release of the photographs and Major General Taguba's report to the media.

19. Senator LEVIN. Secretary Rumsfeld, at the hearing General Myers testified that he had discussed the detainee abuse problem with you in January, recognizing that it had the potential to cause serious problems. Yet you had not fully read the Taguba Report a couple days before the hearing. Given that you were aware of the serious nature of this abuse problem as early as January, why did you not read the Taguba Report as soon as it was completed?

Secretary RUMSFELD. The Taguba Report was initiated on 31 January 2004. An interim report was completed on 12 March and approved by LTG McKiernan on 6 April. LTG Sanchez approved the report's recommendations on 1 May, although the report was publicized by The New Yorker on 30 April. The full Taguba Report numbered in the thousands of pages. I received a briefing from MG Taguba on 6 May 04.

APRIL 28 SENATE BRIEFING

20. Senator LEVIN. Secretary Rumsfeld, you briefed the Senate on April 28, 2004 on Iraq in a classified session. This was the same day that CBS broadcast the photos that General Myers had successfully requested be delayed. However, you never mentioned the detainee abuse scandal to the Senators at that briefing, even though you say you were aware of the seriousness of the issue and of the existence of photos showing the abuse. Given that you knew well before April 28 about the abuse scandal, that there were photos of the abuse, and that General Myers had called CBS in early April to request delay in broadcast of the photos, why did you not inform the Senate of the detainee abuse scandal, even as late as the date on which the photos were broadcast?

Secretary RUMSFELD. As I said in my testimony, one cannot truly appreciate the significance and ramifications of the allegations of detainee abuse at Abu Ghraib until viewing the photographs. At the time of the April 28 briefing, I had not seen the photographs. The command had responded promptly and several criminal investigations were underway when these allegations came to light in January. Public announcements were made then, and again when certain individuals were identified for further investigations in March. Had I seen the photographs before April 28, they would have been part of my brief.

VIEWING THE PHOTOGRAPHS

21. Senator LEVIN. Secretary Rumsfeld, during the hearing you said that you did not see the photos of the abuse until after they were broadcast by CBS, and they appeared in the news media. You also said that you did not have a chance to personally review the photos until the night before the hearing, May 6. Given that you knew of the abuse problem in January and knew of the existence of photos well before they were broadcast, and given that General Myers asked CBS to delay broadcast of the photos in early April, did you ever ask to see the photos before they were broadcast? If not, why not?

Secretary RUMSFELD. As I indicated in my testimony before the committee, hearing a description of abuse, or hearing someone's description of a picture of abuse, does not compare to actually seeing the photographs. It was not until I had seen the photographs that I appreciated the significance and broad ramifications of the abuse allegations. The criminal investigations then underway and publicly announced were appropriate responses to the allegations. The photos were part of a criminal investigation. It is not established practice to reach into criminal investigations higher in the chain of command to review evidence of a possible crime. As I testified, though, in the digital age, with 24/7 news coverage, we need to develop a process to elevate such items to senior officials more rapidly than the current processes allow.

22. Senator LEVIN. Secretary Rumsfeld, given that you knew the nature of the abuse that was under investigation before the photos were broadcast, and that General Myers called CBS in early April to request that broadcast of the photos be delayed because they could cause serious problems, why did you say you did not understand that the photos of the abuse would be very disturbing until you had actually seen the photos? Is it not obvious, even without seeing the actual photos, that a photo of abuse would be very disturbing?

Secretary RUMSFELD. See answer above.

GENEVA CONVENTIONS

23. Senator LEVIN. Secretary Rumsfeld, during your May 4, 2003, interview with Matt Lauer, when speaking about Iraq you stated that: "The decision was made that the Geneva Conventions did not apply precisely, but that every individual would be treated as though the Geneva Conventions did apply." You went on to state in the interview that "the United States Government, the lawyers, made a conscious decision and announced it to the world and announced it to all the people engaged in the detention process that these people would, in fact, be treated as though the Geneva Conventions did apply."

At the May 7, 2004, hearing before the Senate Armed Services Committee, you stated that "the President announced from the outset that everyone in Iraq who was detained is a prisoner of war (POW) and therefore the Geneva Conventions apply. Second, the decision was made that the civilians or criminal elements that are detainees are also treated subject to the Geneva Conventions, although it's a different element of it. I think it's the fourth instead of the third." Furthermore, you replied "absolutely" when asked if "all those in prison had the rights of POWs."

How do you reconcile these statements? Do the Geneva Conventions apply for all detainees in Iraq or are detainees treated in a manner "consistent with" the Conventions?

Secretary RUMSFELD. The Geneva Conventions apply during all phases of Operation Iraqi Freedom. The plans for Operation Iraqi Freedom that were prepared by Commander, U.S. Central Command, and briefed to the President and me before outbreak of hostilities included provisions that clearly stated that enemy prisoners of war, retained persons, civilian internees will be handled and other detainee "operations will be conducted in compliance with the 1949 Geneva Convention and applicable U.S. military regulations." Further, component and supporting commanders were responsible under the plans for Operation Iraqi Freedom for "[e]nsuring treatment of all detained persons is in accordance with the Conventions and other applicable international law." The President directed these plans to be executed. Detention operations during all phases of Operation Iraqi Freedom are required to be conducted in accordance with the Geneva Conventions.

24. Senator LEVIN. Secretary Rumsfeld, when did the President announce that the Geneva Conventions would apply for all detainees in Iraq? How was this announcement made public? What steps were taken to inform coalition forces about this decision? When were they made?

Secretary RUMSFELD. On March 24, 2003, shortly after Operation Iraqi Freedom began, White House spokesman Ari Fleisher, when asked if the Geneva Conventions applied in Iraq, stated that Iraq was a traditional conflict, "[a]nd we have always treated people humanely consistent with our international agreements. In the case of the fight in Iraq, there's no question that it's being done in accordance with the Geneva Conventions."

Prior to the commencement of Operation Iraqi Freedom, Commander, U.S. Central Command, prepared Operational Plan (OPLAN) 1003-V. Appendix 1 to Annex E of OPLAN 1003-V specifically addressed the treatment of the operational plan annex on enemy prisoners of war, retained persons, civilian internees, and other detainees. It outlined responsibilities, policies, and procedures with respect to the handling of detainees, and provided specific guidance that the Geneva Conventions applied to all persons held by U.S. forces. This means of promulgation is consistent with the usual manner in which commanders provide guidance to their subordinate commanders. The subordinate commands would review the OPLAN and draft their own orders. For instance, the CJSC EXORD itself does not specifically address the Geneva Conventions; rather, it refers back to OPLAN 1003-V.

In addition to the promulgation of this OPLAN and its annexes, commanders were responsible for ensuring that detainees were treated in accordance with the Geneva Conventions and applicable international law and that measures were implemented to ensure the forces were aware of and complied with the Law of War.

25. Senator LEVIN. Secretary Rumsfeld, do you believe that the Interrogation Rules of Engagement (ROEs) utilized by the CJTF-7 comply with the Geneva Conventions? What is your legal basis for this understanding?

Secretary RUMSFELD. This matter was thoroughly reviewed by the Kern/Fay investigation. Further, General Sanchez, General Abizaid, and the CJTF-7 Staff Judge Advocate testified before the committee on the matter. I have no independent knowledge or assessment.

26. Senator LEVIN. Secretary Rumsfeld, did you personally review these ROEs prior to their being issued? If not, who did and when?

Secretary RUMSFELD. Neither I nor my staff was ever requested to review the CJTF-7 counter resistance interrogation policy. LTG Sanchez issued his October 12, 2003, policy guidance after consultation with U.S. Central Command staff. He has the authority to promulgate such policies, which were reviewed, as I understand, by the Commander of the U.S. Central Command.

QUESTIONS SUBMITTED BY SENATOR BILL NELSON

PRESIDENTIAL NOTIFICATION

27. Senator BILL NELSON. Secretary Rumsfeld, in your testimony you indicated that General Pace, Vice Chairman of the Joint Chiefs of Staff, had notified the President about the abuse allegations in late January or early February. Could you provide the committee the date of that meeting and any details regarding what the President was told with respect to this case by General Pace?

Secretary RUMSFELD. During the period of time in question, I met with the President once, sometimes twice, weekly and either General Myers or General Pace would accompany me. I cannot recall with clarity at which particular meeting we notified the President of the abuse allegations, nor the details of what was conveyed.

APRIL 28 BRIEFING

28. Senator BILL NELSON. Secretary Rumsfeld, when you appeared before the Senate in a secure setting on April 28, why did you decide not to brief the Members on the abuse allegations and photographs at that meeting?

Secretary RUMSFELD. As I said in my testimony, one cannot truly appreciate the significance and ramifications of the allegations of detainee abuse at Abu Ghraib until viewing the photographs. At the time of the April 28 briefing, I had not seen the photographs. The command had responded promptly and several criminal investigations were underway when these allegations came to light in January. Public announcements were made then, and again when certain individuals were identified for further investigations in March. Had I seen the photographs before April 28, they would have been part of my brief.

[Whereupon, at 2:36 p.m., the committee adjourned.]

ALLEGATIONS OF MISTREATMENT OF IRAQI PRISONERS

TUESDAY, MAY 11, 2004

U.S. SENATE,
COMMITTEE ON ARMED SERVICES,
Washington, DC.

The committee met, pursuant to notice, at 9:36 a.m. in room SD-106, Dirksen Senate Office Building, Senator John Warner (chairman) presiding.

Committee members present: Senators Warner, McCain, Inhofe, Roberts, Allard, Sessions, Collins, Ensign, Talent, Chambliss, Graham, Cornyn, Levin, Kennedy, Byrd, Lieberman, Reed, Akaka, Bill Nelson, E. Benjamin Nelson, Dayton, Bayh, and Clinton.

Majority staff members present: Charles W. Alsup, professional staff member; Gregory T. Kiley, professional staff member; Lucian L. Niemeyer, professional staff member; Paula J. Philbin, professional staff member; Lynn F. Rusten, professional staff member; Scott W. Stucky, general counsel; Diana G. Tabler, professional staff member; and Richard F. Walsh, counsel.

Minority staff members present: Richard D. DeBobes, Democratic staff director; Daniel J. Cox, Jr., professional staff member; Evelyn N. Farkas, professional staff member; Jeremy L. Hekhuis, professional staff member; Gerald J. Leeling, minority counsel; Peter K. Levine, minority counsel; William G.P. Monahan, minority counsel; and Arun A. Seraphin, professional staff member.

Staff assistants present: Michael N. Berger, Andrew W. Florell, and Bridget E. Ward.

Committee members' assistants present: Cord Sterling, assistant to Senator Warner; Christopher J. Paul, assistant to Senator McCain; John A. Bonsell, assistant to Senator Inhofe; Lance Landry, assistant to Senator Allard; Arch Galloway II, assistant to Senator Sessions; Dirk J. Maurer, assistant to Senator Collins; D'Arcy Grisier, assistant to Senator Ensign; Lindsey R. Neas, assistant to Senator Talent; Clyde A. Taylor IV, assistant to Senator Chambliss; Meredith Moseley, assistant to Senator Graham; Christine O. Hill, assistant to Senator Dole; Russell J. Thomasson, assistant to Senator Cornyn; Mieke Y. Eoyang, assistant to Senator Kennedy; Frederick M. Downey, assistant to Senator Lieberman; Elizabeth King, assistant to Senator Reed; Davelyn Noelani Kalipi and Richard Kessler, assistants to Senator Akaka; William K. Sutey, assistant to Senator Bill Nelson; Eric Pierce, assistant to Senator Ben Nelson; Rashid Hallaway, assistant to Senator Bayh; and Andrew Shapiro, assistant to Senator Clinton.

**OPENING STATEMENT OF SENATOR JOHN WARNER,
CHAIRMAN**

Chairman WARNER. The committee meets today for the second of a series of hearings regarding the mistreatment of Iraqi prisoners by some elements, and certain personnel, few in number, I hope, of the Armed Forces, in violation of United States and international law.

Testifying before us today is Major General Antonio M. Taguba, U.S. Army, Deputy Commanding General for Support, Coalition Forces Land Component Command (CFLCC).

On January 31, 2004, General Taguba was appointed by General Sanchez, Commander, Combined Joint Task Force-7 (CJTF-7), to conduct a Procedure-15 investigation into allegations of prisoner abuse at the Abu Ghraib prison. General Taguba's report was received by this committee on Tuesday, May 4, and its related annexes were received yesterday, May 10. As members know, they are in the possession of the committee, and members and staff worked on those reports until very late last night.

Joining General Taguba are Lieutenant General Lance L. Smith, U.S. Air Force, Deputy Commander of Central Command (CENTCOM); and Dr. Stephen A. Cambone, Under Secretary of Defense for Intelligence (USDI).

We welcome our witnesses. General Taguba, I wish to personally commend you for your public service.

General TAGUBA. Yes, sir.

Chairman WARNER. Following the testimony of our witnesses, we'll receive testimony from a second panel of witnesses this afternoon, commencing at 2:30.

As I stated last week, this mistreatment of prisoners represents an appalling and totally unacceptable breach of military regulations and conduct. The damage done to the reputation and credibility of our Nation and the Armed Forces has the potential to undermine substantial gains and the sacrifices by our forces and their families, and those of our allies fighting with us in the cause of freedom.

This degree of breakdown in military leadership and discipline represents an extremely rare chapter in the otherwise proud history of our Armed Forces. It defies common sense, and contradicts all the values for which America stands. There must be a full accounting for the cruel and disgraceful abuse of Iraqi detainees, consistent with our laws and the protections of the Uniform Code of Military Justice (UCMJ).

I'm proud of the manner in which the Armed Forces have quickly reacted to these allegations, undertaken appropriate investigation, and begun disciplinary actions. We are a nation of laws, and we confront abuses of our laws openly and directly.

We have had an apparent breakdown of discipline and leadership at this prison, and possibly at other locations. We think it important to confront these problems swiftly, assuring that justice is done, and take the corrective actions so that such abuses never happen again. At the same time, it is important to remember that our commanders and their troops in Iraq are confronted with a very difficult, dangerous, complex military situation. Defeating insurgents and terrorists who seek to deny freedom and democracy

to all Iraqis and who threaten our troops is the highest priority. Our troops are working very hard and courageously sacrifice to achieve that mission. Intelligence obtained in the course of any military action, obtained in accordance with proper laws and professional procedures, is an essential element of any military campaign.

I was heartened by President Bush's words of support for our men and women of the Armed Forces, as he stated yesterday, in visiting the Department of Defense (DOD)—and I quote our President: "All Americans know the goodness and the character of the United States Armed Forces. No military in the history of the world has fought so hard and so often for the freedom of others. Today, our soldiers, sailors, airmen, and marines are keeping terrorists across the world on the run. They're helping the people of Afghanistan and Iraq build democratic societies. They're defending America with unselfish courage. These achievements have brought pride and credit to this Nation. I want our men and women in uniform to know that America is proud of you, and that I'm honored to be your commander in chief."

Speaking for myself, I feel our President, our Secretary of Defense (SECDEF), Chairman of the Joint Chiefs of Staff (CJCS), and the other officers of our military have very correctly and properly addressed the seriousness of these issues, and I commend them.

We must not forget our overall purpose in Iraq. Success there is absolutely essential. Our men and women in uniform make a remarkable institution in this great America. From time to time it must heal itself, consistent with law and tradition, and that is what we're doing in this particular case. We have a responsibility here in Congress to help them do that, and that is precisely the purpose of these hearings.

Senator Levin.

STATEMENT OF SENATOR CARL LEVIN

Senator LEVIN. Thank you, Mr. Chairman.

Today's hearing continues the committee's examination of the events at Abu Ghraib detention facility and the effort to learn what led to the abuses of Iraqi prisoners so graphically depicted in the photographs that have shocked and disgusted the civilized world; and who may have authorized, encouraged, or suggested those despicable actions. Getting to the truth of what happened and who was responsible is important for our military men and women, for the American people, for the success of our mission in Iraq, and for a watching world.

General Taguba, while your report paints a disturbing picture of horrible abuses and leadership failures at Abu Ghraib, your report reflects an honest and detailed assessment of the situation there, and includes sensible recommendations on how to begin fixing those problems. I thank you for your professionalism in carrying out this service to our Nation.

The hearing we held last week barely scratched the surface of the issues that this committee must examine. It yielded little in the form of detailed information as to how these abuses could possibly have occurred and who was responsible for them, including those

within and without the chain of command whose policy decisions created an environment in which the abuses could occur.

The despicable actions described in General Taguba's report not only reek of abuse, they reek of an organized effort and methodical preparation for interrogation. The collars used on prisoners, the dogs, and the cameras did not suddenly appear out of thin air. These acts of abuse were not the spontaneous actions of lower-ranking enlisted personnel who lacked the proper supervision. These attempts to extract information from prisoners by abusive and degrading methods were clearly planned and suggested by others.

Today, we begin what must be a determined pursuit of the answers to the questions:

Who organized the effort?

Who oversaw it?

Under what directives and policies were these actions implemented?

All of those up and down the chain of command who bear any responsibility must be held accountable for the brutality and humiliation they inflicted on the prisoners and for the damage and dishonor that they brought to our Nation and to the United States Armed Forces, which is otherwise filled with honorable men and women acting with courage and professionalism to bring stability and security and reconstruction to Iraq.

Thank you, Mr. Chairman.

Chairman WARNER. I'll ask the witnesses to rise. [Witnesses sworn.]

In accordance with the time-honored traditions of our country of civilian control over the military, we recognize Secretary Cambone, who is speaking on behalf of the DOD.

Mr. Secretary?

**STATEMENT OF HON. STEPHEN A. CAMBONE, UNDER
SECRETARY OF DEFENSE FOR INTELLIGENCE**

Secretary CAMBONE. Mr. Chairman, thank you.

Members of the committee, we're here today to continue the discussion on the terrible activities at Abu Ghraib, begun last Friday by the SECDEF, the CJCS, and other members of the panel.

Before going further, let me say that we are dismayed by what took place. The Iraqi detainees are human beings. They were in U.S. custody. We had an obligation to treat them right. We didn't do that. That was wrong. I associate myself, without reservation, to the sentiments expressed by the SECDEF. To those Iraqis who were mistreated by members of the U.S. Armed Forces, I offer my deepest apology. It was un-American, and it was inconsistent with the values of our Nation.

Now, a number of issues arose related to those events during the hearing last Friday, which, as Senator Levin has noted, were not fully engaged. I wanted to tick off a short list that we have been developing since then as a way of preparation in answer to the questions we know that you have.

But before I go through those, let me say, again, that we will give you this information today, to the best of our knowledge. We do not have, yet, all the facts related to this case. There are at

least five other investigations ongoing, and we will need that information in order to come to a full understanding.

So, first, with respect to the application of the Geneva Conventions to detainees in Iraq, from the outset of the war in Iraq, the United States Government has recognized and made clear that the Geneva Conventions apply to our activities in that country. Members of our Armed Forces should have been aware of that. If they were not—if they were not—Lieutenant General Sanchez, the CJTF-7 commander, reminded them, on more than one occasion, that the forces under his command operated under that obligation.

Nevertheless, there clearly was a breakdown in following Geneva Conventions procedures at Abu Ghraib, and we are in the process of investigating why that happened.

As Major General Miller, who is now in charge of detainee operations in Iraq, remarked on Saturday, “The procedures established for interrogations in Iraq were sanctioned under the Geneva Conventions and authorized in U.S. Army manuals. All permissible”—permissible—“interrogation activities were within the requirements and boundaries of applicable provisions of the Geneva Conventions.” We are currently investigating why soldiers—some soldiers—at Abu Ghraib did not abide by those understood procedures and guidelines.

Early in the war on terrorism, long before the war in Iraq, the President made a determination that the Geneva Conventions did not apply to al Qaeda detainees. That decision was made because the Geneva Conventions govern conflicts between states, and the al Qaeda is not a state, much less a signatory of the Geneva Conventions. Moreover, the Geneva Conventions forbid the targeting of civilians, and require that military forces wear designated uniforms to distinguish them from noncombatants. Terrorists don’t care about the Geneva Conventions, nor do they abide by its guidelines. They deliberately target civilians, for example, and have brutalized and murdered innocent Americans. To grant terrorists the rights they so cruelly reject would make a mockery of the Geneva Conventions.

Nevertheless, President Bush did order—did order—that detainees held at Guantanamo be treated humanely and consistent with the Geneva Conventions’ principles. In fact, those detainees in the war on terror are being provided with many of the privileges typically afforded to enemy prisoners of war.

The notion that this decision in some way undermined the Geneva Conventions or created a poor climate is false. To the contrary, the administration made this decision with the objective of assuring that those who would claim protection under its auspices, and not act in keeping with its intent, did not abuse the Geneva Conventions. Far from disrespect, the decision was made out of a notion of respect. The notion of a departmental belief that the alleged climate created and led to abuse in Iraq is, therefore, not in keeping with clear and stated determination to adhere to the Geneva Conventions.

Second, Major General Miller’s recommendations. Major General Miller was sent to Iraq—it was late August 2003—based on his experience with the flow of information gained by interrogation at Guantanamo Bay. He was sent under Joint Staff auspices—and, as

I said on Friday before this committee, with my encouragement—to determine if the flow of information to CJTF-7 and back to the subordinate commands could be improved. He laid out an approach to do this in a series of recommendations to General Sanchez. He had no directive authority in that visit.

One recommendation on detention operations was to dedicate and train a detention guard force subordinate to the joint intelligence commander that would, in the words of General Taguba's report and others, "set the conditions for the successful interrogation and exploitation of internees and detainees." In making this recommendation, Major General Miller was underscoring the need for military police (MP) and military intelligence (MI) personnel, both of whom serve different functions, to act in a fashion such that the one, MP, did not undermine the efforts of the other, MI, to discover, during interrogation, the information that was important to coalition forces and to the lives of Iraqi civilians. Consequently, he underscored the need for a legal review of his recommendations by a dedicated command staff judge advocate (SJA).

With respect to detention operations, Major General Miller noted that their purpose is to provide a safe, secure, and humane environment that supports the expeditious collection of intelligence. In addition, he observed that detention operations must be structured to ensure the detention environment focuses the internees' confidence and attention on their interrogators. He recommended training in building the teamwork the interrogator and detention staffs needed to accomplish the objectives.

The order placing the MP at Abu Ghraib under the tactical control of the 205th Military Intelligence Brigade—and here, for more of the detail, I can defer to General Smith—but on November 19, 2003, General Sanchez issued an order effectively placing Abu Ghraib under the tactical control of the 205th Military Intelligence Brigade. This order was within the authority of General Sanchez to give. As I say, Lieutenant General Smith might elaborate on the reasons that the order was given. But what it did is, it gave a senior officer responsibility for the facility. For the facility. We needed someone to take care of such matters as security, force protection, the internal security, living conditions for the troops, and other things. It did not give, as far as I understand it, the MI brigade commander the authority over MP operations. If I might note, if you look at General Karpinski's CNN interview last night, she makes comments to that effect.

Let me stress that the promulgation of the order in no way changed the rules governing the conduct of MP and military personnel in Iraq with respect to the laws of war, the Geneva Conventions, CENTCOM directions, or CJTF-7 directions and instructions.

Third, the role of contractors. Contractors may not perform interrogations except under the supervision of military personnel. There may have been circumstances under which this regulation was not followed. I cannot tell you that it was followed in all respects. This is a matter that General Fay is now examining. In addition, contractors may not supervise or give orders or direction to military personnel. While contractors are not under military discipline—another issue raised on Friday—they are subject to suspension from

their contracts by the government for cause. Furthermore, criminal sanctions for any crimes a contractor may commit may be available in U.S. Federal Court and may be referred to U.S. Federal Court.

Fourth, with respect to the oversight of military intelligence criminal investigation in the operations of combatant commanders, I have, on page 8 of the statement that I prepared for you, listed the roles of the office I presently hold, that of the joint commands and that of the Services. I then go on and talk about oversight of criminal investigations and the role of the DOD Inspector General's (IG) office and the counterintelligence oversight.

On page 9, I begin the actions underway. The SECDEF reviewed those with you on Friday, and I will not take your time here unless the committee wishes to return to them, but to add one development since we were here last, and that is that the SECDEF is now preparing a personal message for the men and women of the Armed Forces, underscoring his dismay over the events at Abu Ghraib, expressing his confidence in the valor and professionalism of the men and women, stressing, once again, that the Geneva Conventions apply to our conflict in Iraq, and expressing his confidence in the ultimate success of our mission in Iraq.

Mr. Chairman, this is an occasion to demonstrate to the world the difference between those who believe in democracy and those who do not. We value human life. We believe in the right to individual freedom and the rule of law. For those beliefs, we send our men and women abroad to protect that right for our own people and to give millions of others hope for freedom in the future. Part of that mission is making sure that when wrongdoing or scandal occurs, it's not covered up, but exposed, investigated, publicly disclosed, and the guilty brought to justice.

I believe we can repair the damage done to our credibility in the region. If we hold true to our principles and continue to keep our commitments to the people of Iraq and Afghanistan, eventually the nobility of that mission will touch the hearts of more people in the Arab world. I am confident of this because of the outstanding service that has been rendered by the vast majority of the men and women of the U.S. Armed Forces.

Thank you, Mr. Chairman.

[The prepared statement of Secretary Cambone follows:]

PREPARED STATEMENT BY HON. STEPHEN A. CAMBONE

Mr. Chairman, members of the committee. We are here today to continue the discussion on the terrible activities at Abu Ghraib begun last Friday by the SECDEF, the CJCS, Acting Secretary of the Army, Army Chief of Staff, and the Deputy Commander, CENTCOM, who is with us today.

Before going further, let me say that we are dismayed by what took place. The Iraqi detainees are human beings, they were in U.S. custody, we had an obligation to treat them right, and we didn't do that. That was wrong. I associate myself without reservation to the sentiments expressed by the SECDEF: "To those Iraqis who were mistreated by members of U.S. Armed Forces I offer my deepest apology. It was un-American, and it was inconsistent with the values of our Nation."

A number of issues related to those events arose during the hearing last Friday or have been the subject of public commentary before or since. I'd like to take a moment to address some of them.

First, with respect to the application of the Geneva Conventions to detainees in Iraq: From the outset of the war in Iraq, the United States government has recog-

nized and made clear that the Geneva Conventions applied to our activities in that country. Members of our Armed Forces should have been aware of that.

If they were not, Lieutenant General Sanchez, CJTF-7 Commander, reminded the forces under his command of the obligation.

Nevertheless, there clearly was a breakdown in following Geneva Conventions procedures at Abu Ghraib, and we are in the process of investigating right now why that happened.

As Major General Miller, who is now in charge of detainee operations in Iraq, remarked on Saturday, the procedures established for interrogations in Iraq were sanctioned under the Geneva Conventions and authorized in U.S. Army manuals. All permissible interrogation activities were within the requirements and boundaries of applicable provisions of the Geneva Conventions.

We are currently investigating why some soldiers at Abu Ghraib did not abide by those understood procedures and guidelines.

Early in the war on terrorism, long before the war in Iraq, the administration made a determination that the Geneva Conventions did not apply to al Qaeda detainees.

That decision was made because the Geneva Conventions govern conflicts between states and the al Qaeda is not a state, much less a signatory of the convention. Moreover, the conventions forbid the targeting of civilians and requiring that military forces wear designated uniforms to distinguish them from noncombatants. Terrorists don't care about the Geneva Conventions nor do they obey its guidelines. They deliberately target civilians, for example, and have brutalized and murdered innocent Americans in their custody.

To grant terrorists the rights they so cruelly reject would make a mockery of the Geneva Conventions. Nonetheless, President Bush did order that detainees held at Guantanamo be treated humanely and consistent with the Geneva Conventions' principles. In fact, those detainees in the war on terror are being provided with many privileges typically afforded to enemy prisoners of war (EPW).

The notion that this decision in some way undermined the Geneva Conventions is false. To the contrary, the administration made this decision with the objective of assuring that those who would claim protection under its auspices and not act in keeping with its intent did not abuse the Geneva Conventions. Far from disrespect, the decision was made out of respect.

The notion of a departmental belief that the alleged climate created and led to abuse in Iraq is therefore not in keeping with clear and stated determination to adhere to the Geneva Conventions.

Second, Major General Miller's recommendations: Major General Miller was sent to Iraq based on his experience with the flow of information gained by interrogation at Guantanamo Bay. He was sent under Joint Staff auspices to determine if the flow of information to CJTF-7 and back to the subordinate commands could be improved. His report laid out an approach to do this in a series of recommendations to General Sanchez.

One recommendation on detention operations was to dedicate and train a detention guard force subordinate to the Joint Interrogation and Detention Center (JIDC) commander that "sets the conditions" for the successful interrogation and exploitation of internees/detainees. In making this recommendation, Major General Miller was underscoring the need for MP and MI personnel to act in a fashion such that the one did not undermine the efforts of the other to discover, during interrogation, information that was important to coalition forces and the lives of Iraqi civilians. Consequently he underscored the need for legal review by a dedicated command SJA.

With respect to detention operations, Major General Miller noted that their purpose is to provide a safe, secure, and humane environment that supports the expeditious collection of intelligence.

In addition, he observed that detention operations must be structured to ensure the detention environment focuses the internee's confidence and attention on their interrogators. He recommended training in building the teamwork between the interrogator and detention staffs to accomplish this objective.

Order placing MPs tactical operation (TACON) to MI: On November 19, 2003 General Sanchez issued an order effectively placing Abu Ghraib, under tactical control of the 205th Military Intelligence Brigade. This order was within the authority of General Sanchez to give and Lieutenant General Smith might elaborate on the reasons this order was given. It gave a senior officer responsibility for the facility. This included force protection, internal security, living conditions for the troops, and so forth. It did not give the MI brigade commander authority over MP operations. Let me stress that its promulgation in no way changed the rules governing the con-

duct of the MP and MI personnel in Iraq with respect to the laws of war, the Geneva Conventions, CENTCOM direction or CJTF-7 directions and instructions.

Third, role of contractors: I am informed that contractors may not perform interrogations except under the supervision of military personnel. There may have been circumstances under which this regulation was not followed. This is a matter that General Fay will examine. In addition, contractors may not supervise or give orders or direction to military personnel. While contractors are not under military discipline, they are subject to suspension from their contract by the government. Furthermore, criminal sanctions for any crimes a contractor may commit may be available in U.S. Federal Court.

Fourth, with respect to oversight of MI, criminal investigation, and the operations of combatant commanders.

- Intelligence support—The USDI ensures that intelligence support across DOD meets warfighters' requirements. This includes ensuring the alignments of policies and programs with current operational requirements, oversight of certain special access programs and development of intelligence-related strategies and assessments. Joint commands provide oversight to "intelligence activities," consistent with their ongoing oversight responsibilities for "operations." Services have responsibility for policy, training, doctrine, and allocation of forces to joint commands. Services are also responsible for counterintelligence investigations and oversight.
- Criminal investigations—The DODIG oversees the military departments' criminal investigative missions. Within the DODIG's office, the office of Investigative Policy and Oversight develops and maintains DOD policy addressing investigative and law enforcement matters in DOD, as well as corresponding legislative issues. Specifically, the Oversight Directorate examines investigative and law enforcement operations and programs to assess effectiveness and efficiency, compliance with established policy and procedures, and need for new or revised policy applicable to investigations or law enforcement.

Actions taken or underway:

A. Lieutenant General Sanchez, Commander, CJTF-7, launched a criminal investigation immediately.

B. He asked Major General Taguba for an administrative review of procedures at the Abu Ghraib facility. These have resulted already in criminal or administrative actions against many individuals, including the relief of the prison chain of command and criminal referrals of several soldiers directly involved in abuse.

C. The Army has launched an IG Review of detainee operations throughout Afghanistan and Iraq, which continues.

D. The Army has initiated an investigation of Reserve training with respect to MI and MP function.

E. Lieutenant General Sanchez asked for an Army Intelligence review of the circumstances discussed in Major General Taguba's report.

F. The SECDEF has directed the Naval IG to review our operations at Guantanamo and the Charleston Naval Brig.

G. Several senior former officials, led by former SECDEF James Schlesinger, have been asked to examine the pace, breadth, and thoroughness of the existing investigations, and to determine whether additional investigations need to be initiated. They are being asked to report their findings within 45 days of taking up their duties, and the SECDEF will encourage them to meet with you to keep you apprised.

H. The SECDEF is preparing a personal message for the men and women of the armed forces underscoring his dismay at events at Abu Ghraib, expressing his confidence in the valor and professionalism, stressing once again that the Geneva Conventions applies to our conflict in Iraq and expressing his confidence in the ultimate success of our mission in Iraq.

This is an occasion to demonstrate to the world the difference between those who believe in democracy and human rights and those who believe in rule by the terrorist code. We value human life; we believe in their right to individual freedom and the rule of law. For those beliefs, we send our men and women of the Armed Forces abroad—to protect that right for our own people and to give millions of others the hope of a future of freedom. Part of that mission is making sure that when wrongdoing or scandal occurs it is not covered up, but exposed, investigated, publicly disclosed—and the guilty brought to justice.

I believe we can repair the damage done to our credibility in the region. If we hold true to our principles and continue to keep our commitments to the people of Iraq and Afghanistan, eventually the nobility of that mission will touch the hearts of more people in the Arab world. I am confident of this because of the outstanding

service that has been rendered by the vast majority of the men and women of U.S. Armed Forces.

Thank you Mr. Chairman. My colleagues have some comments to make.

Chairman WARNER. Thank you very much, Secretary Cambone. General Smith, do you have a few opening comments?

**STATEMENT OF LT. GEN. LANCE L. SMITH, USAF, DEPUTY
COMMANDER, UNITED STATES CENTRAL COMMAND**

General SMITH. Senator Warner, Senator Levin, members of the committee, sir, I'll stand by the comments that I made on Friday, but to add that, once again, on behalf of General Abizaid and all the men and women of CENTCOM, we regret very much that these events ever occurred, and apologize to those who are victims of the abuse.

I would like to assure you that, in every case where the investigations have had recommendations and findings, that we have either implemented the recommendations or are in the process of making the fixes necessary to alleviate the problems, sir.

That in all cases where we have had recommendations and findings, they have either been implemented or we are in the process of implementing fixes to ensure that those gaps that we had, either in policy, procedures, or leadership, are being fixed.

We, at the same time, have a number of investigations that are ongoing that should give us more answers to some of the questions that we all have about what actually went on in the Abu Ghraib prison, the most significant of which is the General Fay investigation over the MI brigade. We will continue to try and make every effort to ensure that we implement the proper procedures, policies, and practices to ensure that this never happens again, sir.

Thank you, Senator Warner.

Chairman WARNER. General Taguba, we welcome you.

**STATEMENT OF MG ANTONIO M. TAGUBA, USA, DEPUTY COM-
MANDING GENERAL FOR SUPPORT, COALITION FORCES
LAND COMPONENT COMMAND**

General TAGUBA. Thank you, sir.

Mr. Chairman, Senator Levin, members of the committee, good morning, all.

I am Major General Antonio M. Taguba, the Deputy Commanding General for Support, U.S. Army Central Command and Coalition Forces Land Component Command (CFLCC) that is headquartered in Camp Arifjan, Kuwait.

Let me continue, sir. On January 24, 2004, I was directed by Lieutenant General David McKiernan, the Commanding General. I sent CFLCC to conduct an investigation into the allegations of detainee abuse at Abu Ghraib prison, which is also known as the Baghdad Central Confinement Facility. I appreciate the opportunity to appear before you today to discuss the purpose, the findings, and the recommendation of that investigation.

The purpose of the investigation, with specific instructions, were as follows:

First, inquire into all of the facts and circumstances surrounding the recent allegations of detainee abuse, specifically allegations of maltreatment at the Abu Ghraib prison.

Second, inquire into detainee escapes and accountability lapses, as reported by CJTF-7, specifically allegations concerning these events at the Abu Ghraib prison.

Third, investigate the training, standards, employment, command policies, internal procedures, and command climate in the 800th MP Brigade, as appropriate.

Finally, make specific findings of fact concerning all aspects of this investigation, and make recommendations for corrective action, as appropriate.

My investigation team consisted of officers and senior enlisted personnel who are military policemen, experts in detention and corrections, judge advocates, psychiatrists, and public affairs officers. At the onset, I did not have MI officers or experts in military interrogation on my team, because the scope of my investigation dealt principally with detention operations and not intelligence-gathering or interrogations operations.

However, during the course of my team's investigation, we gathered evidence pertaining to the involvement of several MI personnel or contractors assigned to the 205th MI Brigade in the alleged detainee abuses at Abu Ghraib. As stated in the findings of the investigation, we recommended that a separate investigation be initiated under the provisions of Procedure 15, Army Regulation 381-10, concerning possible improper interrogation practices in this case. Again, my task was limited to the allegations of detainee abuse involving MP personnel and the policies, procedures, and command climate of the 800th MP Brigade.

As I assembled the investigation team, my specific instructions to my teammates were clear: maintain our objectivity and integrity throughout the course of our mission in what I considered to be a very grave, highly sensitive, and serious situation; to be mindful of our personal values and the moral values of our Nation; to maintain the Army values in all of our dealings; and to be complete, thorough, and fair in the course of the investigation. Bottom line, we'll follow our conscience and do what is morally right.

As agonizing as this investigation was, I commend the exceptional professionalism of my teammates, their extraordinary efforts, and the outstanding manner by which they carried out my instructions. I also commend the courage and selfless service of those soldiers and sailors who brought these allegations to light, discovered evidence of abuse, and turned it over to the military law enforcement authorities. The criminal acts of a few stand in stark contrast to the high professionalism, competence, and moral integrity of countless active, Guard, and Army Reserve soldiers that we encountered in this investigation.

At the end of the day, a few soldiers and civilians conspired to abuse and conduct egregious acts of violence against detainees and other civilians outside the bounds of international law and the Geneva Conventions. Their incomprehensible acts, caught in their own personal record of photographs and video clips, have seriously maligned and impugned the courageous acts of thousands of U.S. and coalition forces. It put into question the reputation of our Nation and the reputation of those who continue to serve in uniform and who would willingly sacrifice their lives to safeguard our freedom.

Thank you for the opportunity to speak before you today, and I look forward to answering your questions.

Thank you, Mr. Chairman.

Chairman WARNER. Thank you very much, General. I must say that I was very heartened by your use of the phrase "Follow our conscience. Do what is morally right."

General TAGUBA. Yes, sir.

Chairman WARNER. I think you've done that.

Colleagues, we'll have a 6-minute round. We take note that votes will start at 11:30, but it's the intention of Senator Levin and myself to continue this hearing on into approximately the 12:30 to 12:45 time frame, in hopes that further opportunity can be given to members for question.

Senator INHOFE. Mr. Chairman, will there be one round?

Chairman WARNER. We'll continue until 12:45, and we'll do our best given the votes. We will try to keep the hearing going during a portion of the votes. Thank you.

Senator INHOFE. Thank you.

Chairman WARNER. Secretary Cambone, my understanding is, and in my briefings with you—and I thank you for discussing these matters with me over the weekend—that your office has the overall responsibility for policy concerning the handling of detainees in the global war on terrorism. Is that correct?

Secretary CAMBONE. Not precisely, sir. The overall policy for the handling of detainees rests with the Under Secretary of Defense for Policy by directive.

Chairman WARNER. Wait a minute. Rests with—

Secretary CAMBONE. The Under Secretary of Defense for Policy by directive. My office became involved in this issue primarily from the perspective of assuring that there was a flow of intelligence back to the commands, and done in an efficient and effective way.

Chairman WARNER. Then I would presume that it would be incumbent upon this committee to get the Under Secretary for Policy over, and let him provide this committee with such knowledge that he has.

Secretary CAMBONE. Yes, sir, and that—his responsibilities—and I have talked with Mr. Feith about this—he issued any number of statements and directives, to the effect that detainees in Iraq, civilian or military, were to be treated under the provisions of the Geneva Conventions.

Chairman WARNER. Did you work with him in that?

Secretary CAMBONE. Yes, sir, I was aware of that work, and knowledgeable of it, and endorsed it, of course.

Chairman WARNER. I'm trying to ascertain the degree to which the civilian authority in the DOD, under the SECDEF, be it yourself—

Secretary CAMBONE. Yes, sir.

Chairman WARNER.—or the other under secretary, reviewed the procedures by which interrogations took place in our places of incarceration, and, most specifically, by those doing it in Iraq.

Secretary CAMBONE. Yes, sir.

Chairman WARNER. You did review the procedures that were being followed for the interrogation of detainees in Iraq?

Secretary CAMBONE. We gave direction that the—the DOD gave direction that the Geneva Conventions were to be followed. The procedures for interrogation are established via the use of—and General Taguba and General Smith can clarify—but they are established on the basis of approved techniques for interrogation. There is a list of those, and you will find them in Army doctrine and manuals.

Chairman WARNER. Right.

Secretary CAMBONE. Those are approved for use by the commanding general. Any exceptions to those activities that he authorizes, he would then set terms and conditions for exceptions to his guidance. At the level of those techniques and so forth, they were signed out at the command level, and not in the DOD.

Chairman WARNER. Now, you've had time to reflect on this. In simple and plain words, how do you think this happened?

Secretary CAMBONE. With the caveat, sir, that I don't know the facts, it's, for me, hard to explain. I have spent a good deal of time over the last 10 days to 2 weeks looking at the various elements of this issue, and I think what we did have here was a problem of leadership with respect to the 372nd Battalion. That was the MP unit.

Chairman WARNER. Failure of leadership starting at what level?

Secretary CAMBONE. That is decidedly more difficult to say, sir. Again, in simple terms, you asked. There was clear direction moving down the chain from the SECDEF to General Abizaid to General Sanchez to those people who were in charge of the MP. That, in this case, is General Karpinski. She had, I think it's eight battalions—

General SMITH. Yes, sir.

Secretary CAMBONE.—eight battalions under her control, lodged at a large number of locations. She, as best I understand it, was not frequently present at Abu Ghraib.

Abu Ghraib, itself—and let's remember the time frame that we're talking about. We're coming out of the period of active combat operations. We have a large number of detainees who are being moved from a facility—

Chairman WARNER. I'm going to ask you to be brief, because I'm holding myself to my time.

Secretary CAMBONE. I understand, sir—moved them from temporary facilities into permanent facilities, the places being mortared and attacked frequently. The local commander was unable to bring order to that place. For that reason, I would argue, General Sanchez looked to Colonel Pappas, the head of the 205th Military Intelligence Brigade, and gave him the responsibility, then, for taking care of Abu Ghraib as an installation.

Chairman WARNER. All right. Now, the reports that were developed by international organizations—the International Committee of the Red Cross (ICRC) and others—in my understanding, they came to your office for an assessment and a determination as to what was to be done in response to those reports.

Secretary CAMBONE. No, the reports that are at issue here is—the ICRC, the International Committee of the Red Cross—

Chairman WARNER. But you told me, I thought, over the weekend, that you—

Secretary CAMBONE. I've seen the report.

Chairman WARNER. You've seen them, and——

Secretary CAMBONE. I have seen it.

Chairman WARNER.—you took some steps to implement some of their recommendations?

Secretary CAMBONE. Steps were taken to implement their recommendations. I saw those reports well after they were issued. The one in question was issued on November 6, 2003. It was addressed, to my knowledge, to General Karpinski, and she replied, at her command level, on December 24, 2003, to the ICRC.

Chairman WARNER. Who else in the building had access to those reports? Did they reach the SECDEF's level?

Secretary CAMBONE. No, sir, they did not. Those reports, those working papers—again, as far as I understand it—were delivered at the command level. The process is designed so that the ICRC can engage with the local commanders and make those kinds of improvements that are necessary in a more collaborative environment than in an adversarial one, and so they tend to try to work these problems at that level.

There was, sir, just for the record, another paper developed by the ICRC, which was delivered to the Coalition Provisional Authority (CPA) in February 2004. That paper is a historical paper. It is a review of activity from March or so of 2003 through the end of January.

Chairman WARNER. My time is running out. Sorry to cut you off. We've asked for those reports.

Secretary CAMBONE. Yes, sir. The SECDEF is going to give them to you, sir.

Chairman WARNER. General Taguba, in your orders were there any restrictions placed upon you by General McKiernan, Generals Sanchez or Abizaid, in the scope of your inquiry? In other words, were you given a free hand to do what you felt had to be done?

General TAGUBA. Sir, the scope, as I described to you, was related to the detainee abuse at Abu Ghraib. However, because there were detention operations under the purview of the 800th MP Brigade, we also looked at the operations at Camp Bucca, the high-value detention facility at Camp Cropper, and also the Mujahedin-e Khalq (MEK) facility at Camp Ashraf.

Chairman WARNER. I ask the same question to you. In simple, layman's language, so it can be understood, what do you think went wrong, in terms of the failure of discipline and the failure of this interrogation process to be consistent with known regulations, national and international? Also, to what extent do you have knowledge of any participation by other than U.S. military—namely, Central Intelligence Agency (CIA) and/or contractors—in the performance of the interrogations?

General TAGUBA. Sir, as far as your last question—I'll answer that first—the comments about participation of other government agencies or contractors were related to us through interviews that we conducted, it was related to our examination of written statements and, of course, some other records.

With regards to your first question, sir, there was a failure of leadership——

Chairman WARNER. In other words, in the material that you've now submitted to the Senate, or the DOD has submitted, we will find in there all of your knowledge with respect to participation by other government agencies.

General TAGUBA. Yes, sir.

Chairman WARNER. It's nine volumes and about 6,000 pages. We just got it yesterday.

General TAGUBA. Yes, sir.

Chairman WARNER. Can you give us a quick synopsis of participation by other U.S. Government agencies?

General TAGUBA. Sir, they refer to other government agencies as OGAs or MIs. When I asked for clarification, it's because of the way they wore their uniform. Some of them did not wear a uniform. So I would ask them to clarify further if they knew any of these people, and they gave us names as stipulated on their statements. They also gave us names of those who are of MI, uniform MI in—personnel in the U.S. Army. That was substantiated by the comments made to us by other witnesses as we conducted our interviews.

Chairman WARNER. All right. In simple words, your own soldiers' language, how did this happen?

General TAGUBA. Failure in leadership, sir, from the brigade commander on down, lack of discipline, no training whatsoever, and no supervision. Supervisory omission was rampant. Those are my comments.

Chairman WARNER. Thank you very much.

Senator Levin.

Senator LEVIN. General Taguba, the ICRC said that the MI officers at the prison confirmed to them that these activities were all part of the MI process. Would you agree with the ICRC that coercive practices, such as holding prisoners naked for extended periods of time, were used, in their words, "in a systematic way" as part of a MI process at the prison?

General TAGUBA. Sir, I did not read the ICRC report.

Senator LEVIN. Would you agree with that conclusion?

General TAGUBA. Yes, sir, based on the evidence that was presented to us and what we gathered and what we reviewed. Yes, sir.

Senator LEVIN. Now, that's more than a failure of leadership. That's an active decision on the part of leadership. It's not just oversight or negligence or neglect or sloppiness, but purposeful, willful determination to use these techniques as part of an interrogation process. Would you include that in your definition of failure of leadership?

General TAGUBA. Yes, sir, they were.

Senator LEVIN. Secretary Cambone told us a few minutes ago that the shift in command at the prison did not mean that the MI commander had command authority over the MPs. But your report says the opposite, that the decision to transfer that command to the MI commander did effectively put that commander in charge of the MP. Now, do you stick by your statement?

General TAGUBA. Is that to me, sir?

Senator LEVIN. Yes.

General TAGUBA. Sir, I did not question the order that was given to Colonel Pappas on the fragmentary order (FRAGO) that he re-

ceived on November 19, 2003. That was not under my purview. I did ask him to elaborate on what his responsibilities were.

Senator LEVIN. Your report states that that change in command, “effectively made an MI officer rather than an MP officer responsible for the MP units conducting detainee operations at that facility.” Is that your conclusion?

General TAGUBA. Yes, sir, because the order gave him TACON of all units that were residing at Abu Ghraib.

Senator LEVIN. All right. Secretary Cambone, do you disagree with that?

Secretary CAMBONE. TACON is——

Senator LEVIN. Do you disagree——

Secretary CAMBONE.—reflected here.

Senator LEVIN.—with what the General just said?

Secretary CAMBONE. Yes, sir.

Senator LEVIN. Pardon?

Secretary CAMBONE. I do. I do not believe that the order placing Colonel Pappas in charge gave him the authority to direct the MP’s activities in direct operational control (OPCON) conditions. Is that true, General?

Senator LEVIN. Thank you. No, it’s okay. Let me just keep going. You’ll have just a disagreement over that.

Secretary Cambone, in an article in last Sunday’s Washington Post, in April 2003 the DOD approved about 20 interrogation techniques for use at Guantanamo that permit reversing normal sleep patterns of detainees and exposing them to heat/cold sensory assault. The use of these techniques required the approval of senior Pentagon officials and, in some cases, of Secretary Rumsfeld, according to that article. These procedures, according to the Pentagon spokesman, Brian Whitman, are controlled and approved on a case-by-case basis. Then it says that the defense and intelligence officials said that similar guidelines had been approved for use on “high-value detainees in Iraq, those suspected of terrorism or of having knowledge of insurgency operations.” Is that true? Were those techniques adopted for Guantanamo? Were they then used or accepted or adopted for Iraq?

Secretary CAMBONE. They are command-level guidelines for the use in interrogation. They are, in some cases, the same; and, in many cases, not.

Senator LEVIN. They’re not the same in Iraq?

Secretary CAMBONE. Not the same.

Senator LEVIN. In Iraq. Can you give us a copy of the guidelines?

Secretary CAMBONE. I can do that.

[The information referred to follows:]

[Deleted.]

Senator LEVIN. Both. So there were specific guidelines for Guantanamo, and they were different from the guidelines for Iraq.

Secretary CAMBONE. I believe that they were, and I will give you the comparisons.

Senator LEVIN. All right. You’ll give those to the committee, then. Let me go to another issue.

There was an interview in the New York Times last week in which Major General Miller said that 50 techniques that the mili-

tary officially uses in prisoner interrogations—including hooding, sleep deprivation, and forcing prisoners into stress positions—have been adopted. Are you familiar with those 50 techniques?

Secretary CAMBONE. As I said in my opening statement, there are those techniques in Army doctrine, yes, sir.

Senator LEVIN. Those are 50 techniques?

Secretary CAMBONE. I don't know that it's 50, sir. There is a—
Senator LEVIN. But it includes stress positions?

Secretary CAMBONE. I believe they do.

[Subsequently, the witness provided the following information for the record:] It does not.

Senator LEVIN. All right, and is that something that you will also supply to the committee?

Secretary CAMBONE. We can supply the manual to you, yes, sir.
[The information referred to follows:]

FM 34-52
INTELLIGENCE
INTERROGATION

HEADQUARTERS, DEPARTMENT OF THE ARMY

DISTRIBUTION RESTRICTION: Approved for public release; distribution is unlimited.

INTELLIGENCE INTERROGATION

Table of Contents

	Page
PREFACE	iv
CHAPTER 1 - MILITARY INTELLIGENCE MISSIONS AND INTELLIGENCE PREPARATION OF THE BATTLEFIELD	1-1
Warfighting Doctrine	1-1
The Intelligence Cycle	1-1
Intelligence Disciplines	1-2
Intelligence and Electronic Warfare Operations	1-3
Mission, Enemy, Troops, Terrain, and Time Available Factors	1-5
Definition of Interrogation	1-6
Definition of Prisoner of War and Enemy Prisoner of War	1-9
Pertinent Articles of Geneva Conventions	1-10
Types of Sources	1-10
Personal Qualities	1-12
Special Areas of Knowledge	1-14
Interrogator Capabilities and Limitations	1-15
Conflicts	1-16
Interrogation Missions	1-17
Drug and Law Enforcement Agency Operations	1-17
CHAPTER 2 - COMPOSITION AND STRUCTURE	2-1
Tactical Operations Center	2-1
Interrogation Below Division	2-2
Division Interrogation Assets	2-3
Corps Interrogation Assets and Organization	2-6
Echelons Above Corps Interrogation Assets and Organization	2-7
Enemy Prisoner of War and Interrogation Facilities	2-9

DISTRIBUTION RESTRICTION: Approved for public release; distribution is unlimited.

*This publication supersedes FM 34-52, 8 May 1987.

FM 34-52

	Page
Corps Facilities	2-10
Echelons Above Corps Facilities	2-12
Medical Company Interrogations	2-12
Interrogation at Brigade and Below	2-12
Special Forces.	2-14
Amphibious Operations	2-14
Airborne Operations	2-15
Interrogator Supported Operations	2-18
Theater Interrogation Facility	2-22
Support Relationships	2-24
CHAPTER 3 - THE INTERROGATION PROCESS	3-1
Collection Priority	3-1
Screening	3-2
Planning and Preparation	3-7
Approach Phase	3-10
Questioning Phase	3-20
Termination Phase.	3-26
Reporting Information	3-28
Interrogation with an Interpreter	3-29
Strategic Interrogations and Debriefings	3-31
CHAPTER 4 - PROCESSING AND EXPLOITING CAPTURED ENEMY	4-1
DOCUMENTS	
Document Categories	4-2
Document Handling	4-4
Document Exploitation	4-7
Translating	4-9
Evacuation Procedures	4-12
APPENDIX A - UNIFORM CODE OF MILITARY JUSTICE EXTRACT	A-1
APPENDIX B - QUESTIONING GUIDES	B-1
APPENDIX C - S2 TACTICAL QUESTIONING GUIDE AND BATTLEFIELD EXPLOITATION	C-1
OF CAPTURED ENEMY DOCUMENTS AND EQUIPMENT	
APPENDIX D - PROTECTED PERSONS RIGHTS VERSUS SECURITY NEEDS	D-1
APPENDIX E - REPORTS	E-1
APPENDIX F - COMMAND LANGUAGE PROGRAM	F-1
APPENDIX G - INDIVIDUAL AND COLLECTIVE TRAINING	G-1

	Page
GLOSSARY	Glossary-1
REFERENCES	References-1
INDEX	Index-1

PREFACE

This manual provides doctrinal guidance, techniques, and procedures governing employment of interrogators as human intelligence (HUMINT) collection assets in support of the commander's intelligence needs. It outlines the interrogator's role within the intelligence collection effort and the supported unit's day-to-day operations. Details are presented on how interrogation assets accomplish their assigned collection mission.

Material in this manual applies to operations in low-, mid-, and high-intensity conflicts. Principles outlined are valid under conditions involving use of electronic warfare (EW) or nuclear, biological, or chemical (NBC) weapons.

This manual is intended for use by interrogators as well as commanders, staff officers, and military intelligence (MI) personnel charged with the responsibility of the interrogation collection effort. Unless otherwise stated, descriptions pertaining to duties, functions, and responsibilities of the G1, G2, G3, G4, and G5 apply to equivalent positions at other organizational echelons.

Interrogation is the HUMINT subdiscipline responsible for MI exploitation of enemy personnel and documents to answer the supported specific information requirements (SIR). These SIR responses, along with those of other MI disciplines, are correlated to satisfy the force commander's priority intelligence requirements (PIR) and intelligence requirements (IR).

During previous armed conflicts, interrogators contributed significantly to the overall intelligence collection effort. They revalidated and established keystone interrogation doctrine (for example, theater interrogation facility [TIF] operations) and documented valuable lessons learned. This knowledge became the genesis for evolving interrogation doctrine.

During Southwest Asia operations, interrogators organized and operated a massive document exploitation (DOCEX) effort. Interrogation units screened, interrogated, or debriefed 49,350 enemy prisoners of war (EPWs), and gathered enough captured enemy documents (CEDs) for DOCEX to fill 18 trailer trucks.

MI interrogation units are a proven and valued collection asset. This manual incorporates the operational experiences and lessons learned. It builds upon existing doctrine and moves interrogation into the 21st century.

These principles and techniques of interrogation are to be used within the constraints established by the following:

- The Uniform Code of Military Justice (UCMJ).
- Geneva Convention for the Amelioration of the Wounded and Sick in Armed Forces in the Field of August 12, 1949, hereinafter referred to as GWS.

- Geneva Convention Relative to the Treatment of Prisoners of War of August 12, 1949, hereinafter referred to as GPW.
- Geneva Convention Relative to the Protection of Civilian Persons in Time of War of August 12, 1949, hereinafter referred to as GC.

Doctrine in this publication conforms with and supports principles contained in FM 34-1.

This publication implements the following Standardization Agreements (STANAGs):

- STANAG 2033, Interrogation of Prisoners of War, Edition 6.
- STANAG 2044, Procedures for Dealing with Prisoners of War, Edition 5.
- STANAG 2084, Handling and Reporting of Captured Enemy Equipment and Documents, Edition 5.

This publication also complies with STANAG 1059 and Quadripartite Standardization Agreements (QSTAGs) 170, 523, and 528.

The use of the terms EPW, detainee, and source are interchangeable during interrogation process.

Unless this publication states otherwise, masculine nouns or pronouns do not refer exclusively to men.

The proponent of this publication is the US Army Intelligence Center. Send comments and recommendations on DA Form 2028 (Recommended Changes to Publications and Blank Forms) to Headquarters, US Army Intelligence Center, ATTN: ATSI-TDL-D, Fort Huachuca, AZ 85613-6000.

CHAPTER 1

MILITARY INTELLIGENCE MISSIONS AND INTELLIGENCE PREPARATION OF THE BATTLEFIELD

This manual is about interrogation operations. The purpose of this chapter is to define the interrogation mission and its critical elements; describe battlefield operations, IEW operations, and the intelligence processes, disciplines, and the mission, enemy, troops, terrain, and time available (METT-T) factors that shape and drive the interrogation process.

It also addresses the personal qualities and special areas of knowledge of the interrogator and the

capabilities and limitations of interrogation. It includes information on the various levels of conflict, interrogation missions, intelligence preparation of the battlefield (IPB) and the intelligence cycle. The level of detail is structured to assist you in understanding the interrogation tactics, techniques, and procedures described in the remainder of the manual.

WARFIGHTING DOCTRINE

Battlefield operations demand seizing and maintaining the initiative. When operations are properly designed and executed, initiative accrues significant benefits from the outset of an operation to final victory. It permits attacking where, when, and what; while forcing the enemy to react and try to adapt to our operations.

To gain the initiative, the commander must—

- See the enemy early and determine the capabilities and intentions of the enemy.
- Find and track enemy follow-on echelons.
- Identify enemy high-value targets (HVTs), which, if successfully attacked, will contribute to the degradation of important enemy battlefield functions.
- Identify, locate, and develop the required targeting data for the attack of high-payoff targets (HPTs), which, if successfully attacked, will contribute to the success of friendly plans.
- Detect enemy weaknesses and develop the necessary data to support the exploitation of these weaknesses.
- Effectively use electronic warfare (EW) assets to support battlefield operations while protecting friendly use of the electromagnetic spectrum.

THE INTELLIGENCE CYCLE

Intelligence operations follow a four-phase process known as the intelligence cycle, which is shown at Figure 1-1. The intelligence cycle is oriented to the

- Determine the enemy's capability and guard against that capability.
- Protect friendly forces and operations from enemy intelligence collection operations.
- Ensure the enemy is defeated.
- Use the weather and terrain to friendly advantage.

The commander uses defensive and offensive operations to destroy enemy first-echelon forces and deep-attack to simultaneously delay, disrupt, and manipulate enemy follow-on forces. The commander anticipates, creates, and exploits windows of opportunity, using flexible battle planning, to gain the initiative through offensive operations.

By effectively employing maneuver and fire support assets, manipulating the enemy, and expertly using the weather and the terrain, the friendly commander can successfully defeat a superior enemy force. OPERATION DESERT STORM is an example of the successful application of this doctrine.

IEW support is vital to the successful planning and execution of battlefield operations at all echelons. Intelligence support at brigade and battalion levels focuses primarily on close operations, while at division it focuses on close and deep operations. Corps is the focal point for intelligence operations that support rear and deep operations.

commander's mission. Supervising and planning are inherent in all phases of the cycle.

FM 34-52

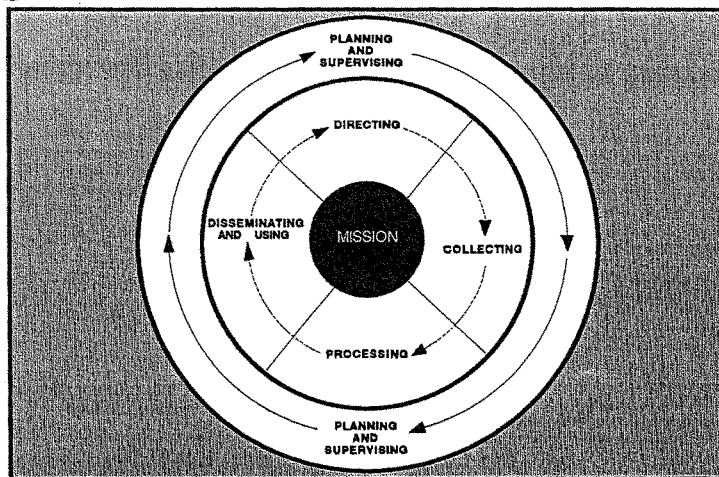

Figure 1-1. The Intelligence cycle.

The intelligence cycle is continuous. Although the four phases are conducted in sequence, all are conducted concurrently. While available information is processed and additional information is collected, the

intelligence staff is planning and directing the collection effort to meet new demands. Previously collected and processed information (intelligence) is disseminated as soon as it is available or needed.

INTELLIGENCE DISCIPLINES

The IEW system includes three MI disciplines: signals intelligence (SIGINT), imagery intelligence (IMINT), and HUMINT. Intelligence interrogation falls within the realm of HUMINT.

SIGINT

SIGINT is derived from the intercept, analysis, and exploitation of threat communications and noncommunications radio-electronic emissions.

IMINT

IMINT is obtained from the analysis of radar, photographic, infrared, and electro-optical imagery.

HUMINT

HUMINT is obtained from information collected from human sources and consists of the following intelligence collection operations:

- Interrogation of EPWs, civilian detainees, insurgents, defectors, refugees, displaced persons, and agents or suspected agents.
- Long-range surveillance (LRS) patrols.
- Strategic debriefing.
- Controlled collection operations.
- Open-source exploitation, to include publications and broadcasts.
- Reports of contact from forward units.
- Observation and listening posts.
- Low-level source operations (LLSO).
- HUMINT liaison contacts.

After World War II, the US General Board on Intelligence surveyed 54 division G2s, 18 corps G2s, and 7

Army G2s. It concluded that 43 percent of all intelligence produced in the European theater of operations was from HUMINT, and 84 percent of the HUMINT was from interrogation. The majority of those surveyed agreed that interrogation was the most valuable of all collection operations.

HUMINT is vital in all combat operations, regardless of echelon or intensity of conflict. By nature, HUMINT lends itself to the collection of information about the enemy's thought processes and intentions. HUMINT can provide information on almost any topic of intel-

ligence interest, including order of battle (OB) factors, as well as scientific and technical (S&T) intelligence subjects. During OPERATION DESERT STORM, interrogators collected information which helped to—

- Develop a plan to breach Iraqi defensive belts.
- Confirm Iraqi supply-line interdiction by coalition air strikes.
- Identify diminishing Iraqi troop morale.
- Identify a US PW captured during the battle of Kafji.

INTELLIGENCE AND ELECTRONIC WARFARE OPERATIONS

The intelligence cycle supports six tasks which are common to all echelons and which must be worked, at least in part, concurrently to satisfy the needs of the commander. The commander may have to prioritize these functions when resource and time constraints dictate.

INDICATIONS AND WARNING (I&W)

I&W identifies major shifts in enemy tactics, operations, and strategy which will set or change the terms of battle. They protect the commander from surprise and identify areas or times of risk by detecting enemy actions that are counter to planning assumptions.

- At the operational level, they identify potential enemy action and determine the need for a military response and the probability of hostilities.
- At the tactical level, they focus on the timing of hostilities rather than on their probability.

I&W prevent surprise and minimize risk through the early identification of enemy activities and capabilities.

INTELLIGENCE PREPARATION OF THE BATTLEFIELD

IPB integrates the environment with the enemy's fighting doctrine and actions. It reveals his capabilities and vulnerabilities and allows the commander to systematically predict his actions. It also allows him to understand the battlefield and how to synchronize all of his battlefield operating systems for maximum effect.

The results of IPB and staff wargaming are used to coordinate and synchronize the intelligence system regardless of the echelon at which it is performed or the intensity of conflict. IPB is more than preparation of the field of battle during hostilities. IPB considers the

entire environment of conflict, supporting contingency as well as planning operations.

- At the strategic level, IPB focuses on all factors that contribute to military potential and includes political, economic, sociological, and S&T aspects of the enemy's ability and intent to conduct military operations.
- At the operational level, IPB identifies the enemy's political, economic or military center of gravity, the lines of operation, and the points in time and geography where the decisive engagements of a campaign will occur. It also predicts the courses of action (COAs) the enemy is likely to follow. This is done by incorporating political, economic, social, and geographical factors, as well as military factors (such as his military potential and ability to apply air, ground, and naval power).
- At the tactical level, IPB focuses on the details of the terrain, weather, and enemy. It predicts and prioritizes the enemy's COAs and synchronizes the application of combat power on identified decisive points.

In mid-intensity conflict (MIC) to high-intensity conflict (HIC), IPB focuses on the traditional aspects of terrain, weather, and enemy. Many of the factors evaluated in IPB at the strategic level are used during IPB for low-intensity conflict (LIC) at the operational and tactical levels.

Social, economic, and political factors that affect the environment of conflict are considered in IPB. The population must be examined in as much detail as the enemy and the terrain to understand what an enemy can or cannot do. Figure 1-2 shows the intelligence cycle using IPB.

FM 34-52

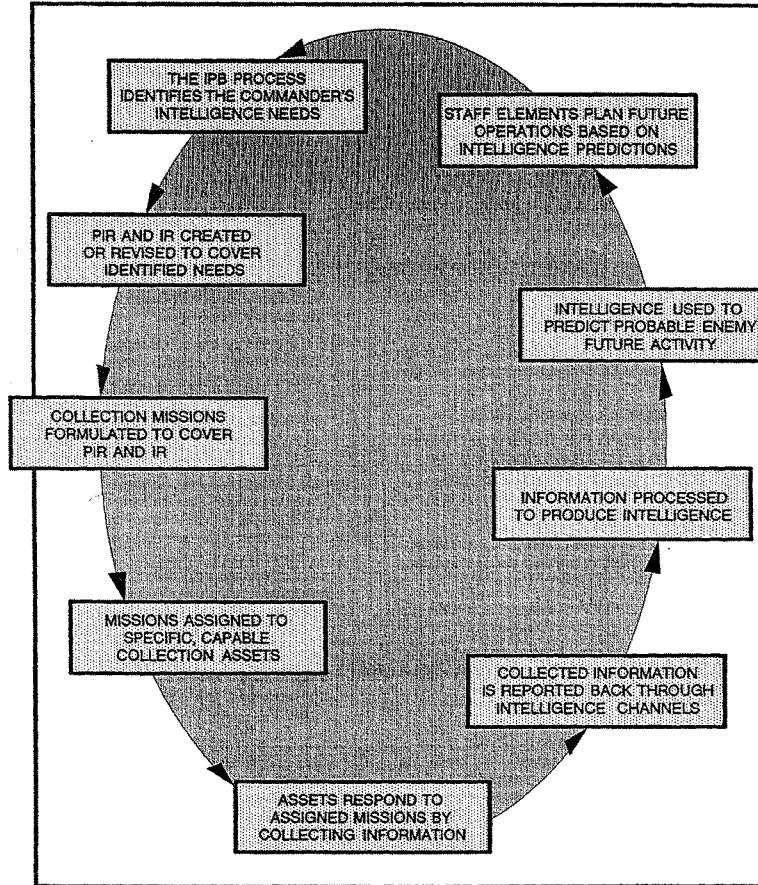

Figure 1-2. Intelligence cycle using IPB.

SITUATION DEVELOPMENT

Situation development confirms or denies the enemy COAs predicted in IPB. It confirms predicted centers of gravity and decisive points and identifies enemy strengths and vulnerabilities. This enables the commander to make timely decisions and effectively apply his combat power.

TARGET DEVELOPMENT AND TARGET ACQUISITION

Target development and target acquisition provide targets and targeting data for attacks by fire, maneuver, and electronic means. They identify and locate those targets that will have the greatest impact on the campaign's decisive engagements. These include deep operational reserves, strategic and operational level command, control, and communications (C²) nodes, key lines of communication, and air and naval staging facilities throughout the enemy's depth that contribute to his combat potential.

At the tactical level, they address those HVTs that directly contribute to the application of combat power at decisive points on the battlefield.

BATTLE DAMAGE ASSESSMENT (BDA)

BDA provides the commander with the effect of friendly operations on the enemy. It focuses on the enemy's remaining military capabilities and potential. At the operational level, it also considers the

MISSION, ENEMY, TROOPS, TERRAIN, AND TIME AVAILABLE FACTORS

The METT-T factors are important to the commander when planning interrogation operations. METT-T determines how the commander will use interrogation assets. The effect of METT-T on interrogation missions is discussed below.

MISSION SUPPORT

The supported force's mission bears directly on how the interrogation element will be employed. In cordon and search operations, commanders may determine interrogators are best suited to screen the populace in order to identify insurgents and their supporters. In counter-drug operations, commanders may use interrogators to exploit documents and to train US and foreign agents in interrogation techniques. In all conflicts, the focus will be on EPW interrogation and CED exploitation.

The mission influences interrogation operations in other ways. For example, if the force's mission is offen-

campaign's effects on the enemy's economy and operational infrastructure as well as his military force structure.

BDA is focused on providing effects of particular strikes and attacks, or a series of them. BDA is performed by the same collection assets used to satisfy the commander's intelligence and targeting priorities; therefore, BDA cannot be performed continuously without degradation of other capabilities, such as situation development and targeting. The commander must prioritize the BDA effort, identifying what he must know and when he must know it, just as he does for his PIR and targeting priorities.

FORCE PROTECTION

Force protection identifies friendly vulnerabilities and the enemy's efforts to exploit them. At the operational level, it includes the early identification of significant improvements in weapon lethality, the introduction of weapons of mass destruction into the conflict, or the commitment of terrorist or other unconventional forces into friendly rear areas.

Force protection goes beyond countering enemy intelligence and includes the protection of all forces that contribute to our combat power. At the tactical level, it emphasizes measures to counter the enemy's intelligence collection capabilities and to protect the force from enemy action.

sive, interrogation elements must be highly mobile, with secure communications to the supported G2 or S2. They must be constantly prepared to move forward with the element they are supporting. This limits time available for exploitation and dissemination.

On the other hand, if the mission is defensive, interrogation elements have more time to exploit individual sources. They may also have more flexibility to exploit EPWs or detainees and CEDs, to fulfill the commander's intent to construct operational graphics.

Collection requirements vary according to echelon. Strategic echelon requirements reflect the wide scope of interest of the theater and national command authority (NCA); whereas, tactical PIR and IR--and resultant SIR--reflect the immediate, more narrowly focused intelligence interest of the maneuver commander.

FM 34-52

ENEMY

The enemy, and our knowledge of the enemy, can influence interrogator assignments and the complexity of the exploitation process. One factor which affects interrogation operations is the type of opposing enemy force. The techniques and procedures used to collect from insurgents in a LIC may differ from those used to collect from regular enemy forces in a MIC to HIC.

For example, an EPW from a regular forces unit may have undergone political indoctrination, but his commitment to his unit may not be as strong as that of the insurgent who is passionately committed to an ideal. Thus, interrogators may have more difficulty persuading the insurgent to talk.

Another factor affecting interrogation operations is our current intelligence holdings on the enemy force and the interrogator's understanding of the threat. Our intelligence holdings on the composition of a newly formed insurgent organization usually will not be as complete as holdings on the composition of a regular enemy force. Thus, the focus of interrogation efforts in the early stages of a LIC may be on enemy force composition; whereas, the focus in a MIC or HIC may be on enemy force missions or intentions.

Cultural aspects also affect interrogation missions. The employment of some basic interrogation techniques will differ based on the ethnic and cultural background of the enemy, and our failure to understand and adapt to this could hamper the collection effort.

TROOPS

The number, experience level, and language proficiency of interrogators affect the tactical employment of interrogation elements. Due to the limited number of interrogators at any echelon, interrogation element commanders have to pick from available interrogators. They must manage personnel to ensure the most experienced are used to the best advantage (for example, to exploit complex enemy documents) and select EPWs most likely to answer SIR.

Interrogation element commanders often have to contend with a mismatch between language-qualified personnel assigned to the unit and languages needed to perform the mission. They overcome the mismatch by acquiring local national (LN) interpreter support

DEFINITION OF INTERROGATION

Interrogation is the process of questioning a source to obtain the maximum amount of usable information.

through the Assistant Chief of Staff, G1 (Personnel). They can also augment their interrogators by requesting other available linguists within the supported command to serve as interpreters.

Another troop-related factor which affects interrogation operations is the training of all soldiers on EPW handling and evacuation. EPW treatment during the early stages of capture is critical to the success of subsequent interrogations. The availability of military police (MP) support at brigade and above can enhance interrogation activities. Interrogation operations are more effective in a controlled environment where EPWs are adequately guarded.

TERRAIN

Terrain and weather are relevant to interrogator operations and affect site deployments, communications, and mobility. MP must ensure proper shelter and security for the EPW facility if it is collocated or immediately adjacent to the EPW collecting point or internment facility.

TIME AVAILABLE

Information collected through interrogation operations is valuable only if it is reported in a timely manner. Exploitation procedures may need to be adjusted to make the most use of time available. At the tactical level, interrogations will be brief, PIR driven, and reported in concise formats such as size, activity, location, unit, time, equipment (SALUTE).

At the operational and strategic levels, time will generally allow for a more expanded interrogation effort and flexible reporting format, such as the intelligence information report (IIR).

The challenge is for interrogators to be proficient linguists and skilled members of a highly organized collection activity. This ensures the acquisition of the maximum amount of pertinent information regardless of time available.

Like other intelligence assets, interrogators must serve the commander. Interrogation operations are of no value unless they contribute to the accomplishment of the supported commander's mission. To understand the interrogator's role in mission accomplishment, one must understand the interrogation process.

The goal of any interrogation is to obtain reliable information in a lawful manner, in a minimum amount of

time, and to satisfy intelligence requirements of any echelon of command. Sources may be—

- Civilian internees.
- Insurgents.
- EPWs.
- Defectors.
- Refugees.
- Displaced persons.
- Agents or suspected agents.
- Other non-US personnel.

A good interrogation produces needed information which is timely, complete, clear, and accurate. An interrogation involves the interaction of two personalities—the source and interrogator. Each contact between these two may differ because of individual characteristics and capabilities of the participants. Furthermore, the circumstances of each contact and physical environment vary.

Other forms of intelligence interrogations include interviews, debriefings, and elicitations. There are certain principles which generally apply to all types of interrogations; namely, the objective, the prohibition against use of force, and security.

OBJECTIVE

Each interrogation must be conducted for a definite purpose. The interrogator must keep this purpose firmly in mind as he proceeds to obtain usable information to satisfy the assigned requirement, and thus contribute to the success of the unit's mission.

The objective may be specific—Establish the exact location of an ammunition storage facility. Or it may be general—Seek to obtain OB information about a specific echelon of the enemy forces.

In either case, the interrogator must use the objective as a basis for planning and conducting the interrogation. He should attempt to prevent the source from becoming aware of the true objective of the interrogation. The interrogator should not concentrate on the objective to the extent he overlooks or fails to recognize and exploit other valuable information extracted from the source.

For example, during an interrogation, the interrogator learns of the presence of a heretofore unknown, highly destructive weapon. Although this information

may not be in line with his specific objective, the interrogator must develop this important lead to obtain all possible information concerning this weapon. It becomes obvious an interrogation objective can be changed as necessary or desired.

PROHIBITION AGAINST USE OF FORCE

The Intelligence Staff Officer (J2, G2, or S2) has responsibility for all command intelligence functions. He assists the commander by—

- Supervising the collection, evaluation, and interpretation of all intelligence information.
- Disseminating intelligence to appropriate higher, lower, and adjacent units.
- Assuming primary responsibility to ensure that all command intelligence functions are conducted in accordance with international, US, and other applicable law and policy. Specifically, the J2, G2, or S2 is responsible to ensure the GWS, GPW, and GC are not violated by intelligence personnel.

One of the significant means used by the intelligence staff is the interrogation of the following:

- EPWs.
- Captured insurgents.
- Civilian internees.
- Other captured, detained, or retained persons.
- Foreign deserters or other persons of intelligence interest.

These persons are protected by the Geneva Conventions for the Protection of War Victims of August 12, 1949, as they relate to captured wounded and sick enemy personnel (GWS), retained enemy medical personnel and chaplains (GWS), enemy prisoners of war (GPW), and civilian internees (GC). Captured insurgents and other detained personnel whose status is not clear, such as suspected terrorists, are entitled to PW protection until their precise status has been determined by competent authority.

In conducting intelligence interrogations, the J2, G2, or S2 has primary staff responsibility to ensure these activities are performed in accordance with the GWS, GPW, and GC, as well as US policies, regarding the treatment and handling of the above-mentioned persons.

FM 34-52

The GWS, GPW, GC, and US policy expressly prohibit acts of violence or intimidation, including physical or mental torture, threats, insults, or exposure to inhumane treatment as a means of or aid to interrogation.

Such illegal acts are not authorized and will not be condoned by the US Army. Acts in violation of these prohibitions are criminal acts punishable under the UCMJ. If there is doubt as to the legality of a proposed form of interrogation not specifically authorized in this manual, the advice of the command judge advocate should be sought before using the method in question.

Experience indicates that the use of prohibited techniques is not necessary to gain the cooperation of interrogation sources. Use of torture and other illegal methods is a poor technique that yields unreliable results, may damage subsequent collection efforts, and can induce the source to say what he thinks the interrogator wants to hear.

Revelation of use of torture by US personnel will bring discredit upon the US and its armed forces while undermining domestic and international support for the war effort. It also may place US and allied personnel in enemy hands at a greater risk of abuse by their captors. Conversely, knowing the enemy has abused US and allied PWs does not justify using methods of interrogation specifically prohibited by the GWS, GPW, or GC, and US policy.

Limitations on the use of methods identified herein as expressly prohibited should not be confused with psychological ploys, verbal trickery, or other nonviolent or noncoercive ruses used by the interrogator in the successful interrogation of hesitant or uncooperative sources.

The psychological techniques and principles in this manual should neither be confused with, nor construed to be synonymous with, unauthorized techniques such as brainwashing, physical or mental torture, or any other form of mental coercion to include drugs that may induce lasting and permanent mental alteration and damage.

Physical or mental torture and coercion revolve around eliminating the source's free will, and are expressly prohibited by GWS, Article 13; GPW, Articles 13 and 17; and GC, Articles 31 and 32. Torture is defined as the infliction of intense pain to body or mind

to extract a confession or information, or for sadistic pleasure.

Examples of physical torture include—

- Electric shock.
- Infliction of pain through chemicals or bondage (other than legitimate use of restraints to prevent escape).
- Forcing an individual to stand, sit, or kneel in abnormal positions for prolonged periods of time.
- Food deprivation.
- Any form of beating.

Examples of mental torture include—

- Mock executions.
- Abnormal sleep deprivation.
- Chemically induced psychosis.

Coercion is defined as actions designed to unlawfully induce another to compel an act against one's will. Examples of coercion include—

- Threatening or implying physical or mental torture to the subject, his family, or others to whom he owes loyalty.
- Intentionally denying medical assistance or care in exchange for the information sought or other cooperation.
- Threatening or implying that other rights guaranteed by the GWS, GPW, or GC will not be provided unless cooperation is forthcoming.

Specific acts committed by US Army personnel may subject them to prosecution under one or more of the following punitive articles of the UCMJ:

- Article 78 - Accessory after the fact.
- Article 80 - Attempts (to commit one of the following offenses).
- Article 81 - Conspiracy (to commit one of the following offenses).
- Article 93 - Cruelty and maltreatment.
- Article 118 - Murder.
- Article 119 - Manslaughter.
- Article 124 - Maiming.

- Article 127 - Extortion.
- Article 128 - Assault (consummated by battery; with a dangerous weapon; or intentionally inflicting grievous bodily harm).
- Article 134 - Homicide, negligent:
 - Misprision of a serious offense (taking some positive act to conceal a serious crime committed by another).
 - Soliciting another to commit an offense.
 - Threat, communicating.

See Appendix A for the text of these offenses.

While using legitimate interrogation techniques, certain applications of approaches and techniques may approach the line between lawful actions and unlawful actions. It may often be difficult to determine where lawful actions end and unlawful actions begin. In attempting to determine if a contemplated approach or technique would be considered unlawful, consider these two tests:

- Given all the surrounding facts and circumstances, would a reasonable person in the place of the person being interrogated believe that his rights, as guaranteed under both international and US law, are being violated or withheld, or will be violated or withheld if he fails to cooperate.
- If your contemplated actions were perpetrated by the enemy against US PWs, you would believe such actions violate international or US law.

If you answer yes to either of these tests, do not engage in the contemplated action. If a doubt still remains as to the legality of a proposed action, seek a legal opinion from your servicing judge advocate.

DEFINITION OF PRISONER OF WAR AND ENEMY PRISONER OF WAR

A PW is a US or allied person detained by an enemy power. An EPW is a person detained by US or allied powers. The first issue interrogators must deal with is who must be afforded PW treatment. Figure 1-3 paraphrases Article 4 of the GPW. In addition, the following personnel shall be treated as PWs: Persons belonging, or having belonged, to the armed forces of the occupied country, if—

The approaches, psychological techniques, and other principles presented in this manual must be read in light of the requirements of international and US law as discussed above.

Authority for conducting interrogations of personnel detained by military forces rests primarily upon the traditional concept that the commander may use all available resources and lawful means to accomplish his mission and to protect and secure his unit.

It is the stated policy of the US Army that military operations will be conducted in accordance with the law of war obligations of the US. The GWS, GPW, and GC establish specific standards for humane care and treatment of enemy personnel captured, retained, or detained by US military forces and its allies. Suspected or alleged violations of these standards will be reported, investigated and, if appropriate, referred to competent authority for trial or other disposition. Violations of the GWS, GPW, or GC committed by US personnel normally constitute violations of the UCMJ.

The commander is responsible for ensuring that the forces under his command comply with the GWS, GPW, and GC. Should violations occur in the conduct of warfare, the commander bears primary responsibility for investigating and prosecuting violations.

SECURITY

The interrogator, by virtue of his position, possesses a great deal of classified information. He is aware his job is to obtain information, not impart it to the source. He safeguards military information as well as the source of that information.

This becomes very clear when one considers that among those persons with whom the interrogator has contact, there are those attempting to collect information for the enemy. The interrogator is alert to detect any attempt made by the source to elicit information.

- The occupying power considers it necessary by reason of such allegiance to intern them; in particular, if—
- Such persons have made an unsuccessful attempt to rejoin the armed forces to which they belong and which are engaged in combat; or

FM 34-52

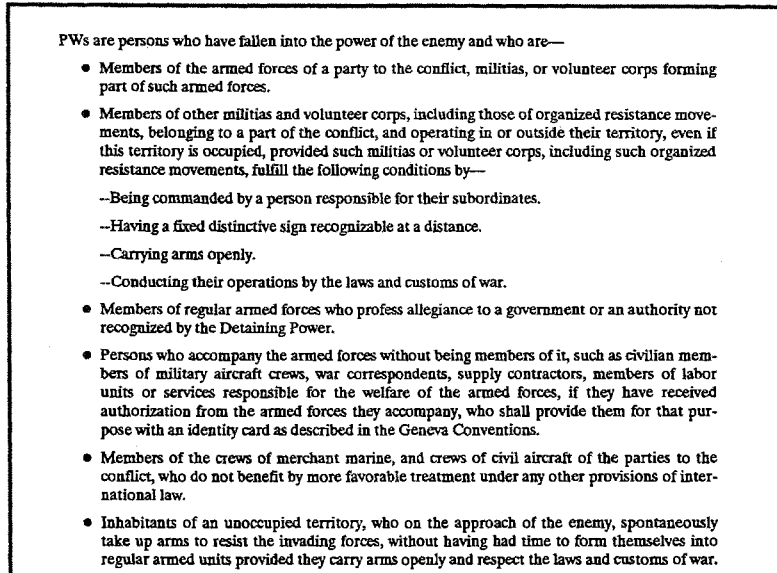

Figure 1-3. Definition of prisoner of war (GPW).

- Where they fail to comply with a summons made to them with a view to internment.

Obviously, there are many personnel who qualify for and require treatment as PWs. If there is any question whether a person should be treated as a PW, treat the

individual as such. The determination whether an individual qualifies as a PW is a Staff Judge Advocate (SJA) function, but has a direct impact on the interrogation effort due to GPW requirements. It is especially important in LICs to distinguish between PWs and criminals.

PERTINENT ARTICLES OF GENEVA CONVENTIONS

Several articles of the GPW apply to interrogators and interrogation operations. The articles

most commonly used by interrogators are shown in Figure 1-4.

TYPES OF SOURCES

The interrogator encounters many sources who vary greatly in personality, social class, civilian occupation, military specialty, and political and religious beliefs. Their physical conditions may range from near death to

perfect health; intelligence levels may range from well below average to well above average; and security consciousness may range from the lowest to the highest.

Article 13--PWs must be humanely treated. Any unlawful act or omission by the Detaining Power causing death or seriously endangering the health of a PW in its custody is prohibited. PWs must always be protected, particularly against acts of violence or intimidation and against insults and public curiosity.

Article 14--PWs are entitled, in all circumstances, to respect for their persons and honor. Women shall be treated with all regard due their sex, and shall always benefit by treatment as favorable that granted men.

Article 15--The Power detaining PWs shall provide, free of charge, for the maintenance and medical attention required by their state of health.

Article 17--This article covers several requirements with direct impact on interrogation.

- Every PW, when questioned on the subject, is bound to give only his surname, first names and rank, date of birth, and army, regimental, personal or (SIC) serial number, or failing this, equivalent information. If he willfully infringes this rule, he may render himself liable to a restriction of the privileges (emphasis added) accorded to his rank or status.
- For example, this does not mean if a prisoner fails to give this information he loses status as a prisoner, only special privileges. An example might be an officer who fails to identify himself as such. An officer cannot be compelled to work (Article 49). An officer who fails to identify himself as such could lose this privilege.
- The questioning of PWs shall be carried out in a language they understand.
- No physical or mental torture nor any other form of coercion may be inflicted on EPWs to secure from them information of any kind whatsoever. EPWs who refuse to answer may not be threatened, insulted, or exposed to unpleasant or disadvantageous treatment of any kind.

Article 18--All effects and articles of personal use, except arms, horses, military equipment and documents, shall remain in the possession of PWs. They will also retain their metal helmets, gas masks, and like articles issued for personal protection. Effects and articles used for their clothing or feeding shall also remain in their possession, even if such effects and articles belong to their regulation military equipment.

- Badges of rank and nationality, decorations and articles having above all a personal or sentimental value may not be taken from PWs.
- Sums of money carried by PWs may not be taken away from them except by order of an officer, and after the amount and particulars of the owner have been recorded in a special register and an itemized receipt has been given, legibly inscribed with the name, rank, and unit of the person issuing said receipt.

Article 19--PWs shall be evacuated, as soon as possible after their capture, to camps situated in an area far enough from the combat zone for them to be out of danger. Only those PWs, who, owing to wounds and sickness, would run greater risks by being evacuated than by remaining where they are, may be temporarily kept back in a danger zone.

Article 33--Medical personnel and chaplains, while retained by the Detaining Power with a view to assisting PWs, shall not be considered as PWs. They shall, however, receive as a minimum, the benefits and protection of the Geneva Convention. They shall continue to exercise their medical and spiritual functions for the benefits of PWs.

Figure 1-4. Pertinent articles of the GPW.

FM 34-52

Sources may be civilian internees, insurgents, EPWs, defectors, refugees, displaced persons, and agents or suspected agents. Because of these variations, the interrogator makes a careful study of every source to evaluate his mental, emotional, and physical state, and uses it as a basis for interrogation. He deals mainly with three categories of sources: cooperative and friendly, neutral and nonpartisan, and hostile and antagonistic.

COOPERATIVE AND FRIENDLY

A cooperative and friendly source offers little resistance to interrogation, and normally speaks freely on almost any topic introduced, other than those which tend to incriminate or degrade him personally. To obtain the maximum amount of information from cooperative and friendly sources, the interrogator takes care to establish and preserve a friendly and cooperative atmosphere by not inquiring into those private affairs which are beyond the scope of the interrogation. At the same time, he must avoid becoming overly friendly and losing control of the interrogation.

NEUTRAL AND NONPARTISAN

A neutral and nonpartisan source is cooperative to a limited degree. He normally takes the position of answering questions asked directly, but seldom volunteers information. In some cases, he may be afraid to answer for fear of reprisals by the enemy. This often is the case in LIC where the people may be fearful of insurgent reprisals. With the neutral and nonpartisan source, the interrogator may have to ask many specific questions to obtain the information required.

HOSTILE AND ANTAGONISTIC

A hostile and antagonistic source is most difficult to interrogate. In many cases, he refuses to talk at all, and offers a real challenge to the interrogator. An interrogator must have self-control, patience, and tact when dealing with him.

At lower tactical echelons, there is generally insufficient time available to effectively interrogate a hostile or antagonistic source. When time is available, and the

PERSONAL QUALITIES

An interrogator should possess an interest in human nature and have a personality which will enable him to gain the cooperation of a source. Ideally, these and other personal qualities would be inherent in an interrogator; however, in most cases, an interrogator can cultivate these qualities if he has the desire and is willing to

source appears to be an excellent target for exploitation, the source should be segregated and approached in an effort to obtain his cooperation. Because of possible high stress and frustration levels that such a source may invoke in you, great care must be taken to maintain your self-control. No matter what the source says or does, you must abide by the provisions of the law of war as previously discussed.

The absence of the use of threats in interrogation is intentional, as threats in and of themselves constitute a form of coercion. Any attempt at enforcement of a threat would constitute an act prohibited by the GWS, GPW, or GC and is punishable under the UCMJ.

A hostile or antagonistic source may be best exploited at echelons where sufficient time and resources will generally be available.

The successful interrogator is a skilled professional who is able to rapidly evaluate sources of information and adapt his approaches and techniques accordingly. The interrogator extracts intelligence from two primary sources: human sources and material sources (primarily CEDs). The senior interrogator determines which of these sources may be most effectively exploited to meet the supported commander's PIR and IR.

CEDs (see Chapter 4) include any piece of recorded information which has been in the possession of a foreign nation and comes into US possession. This includes US documents which the foreign nation may have possessed. There are many ways to acquire a document; some are found in the possession of human sources, on enemy dead, or on the battlefield. There are three types of documents:

- Official (government or military) documents such as overlays, field orders, maps, and codes.
- Personal (private or commercial) documents such as letters, diaries, newspapers, and books.
- Identity (government or military) documents such as cards and books.

devote time to study and practice. Some desirable personal qualities in an interrogator are discussed below.

MOTIVATION

Motivation is the most significant factor to achieve success. Without motivation, other qualities lose their significance. The stronger the motivation, the more

successful the interrogator. An interrogator may be motivated by several factors; for example:

- An interest in human relations.
- A desire to react to the challenge of personal interplay.
- An enthusiasm for the collection of information.
- A profound interest in foreign languages and cultures.

ALERTNESS

The interrogator must be constantly aware of the shifting attitudes which normally characterize a source's reaction to interrogation. The interrogator—

- Notes the source's every gesture, word, and voice inflection.
- Determines why the source is in a certain mood or why his mood suddenly changed. It is from the source's mood and actions the interrogator determines how to best proceed with the interrogation.
- Watches for any indication the source is withholding information.
- Watches for a tendency to resist further questioning, diminishing resistance, contradictions, or other tendencies, to include susceptibility.

PATIENCE AND TACT

The interrogator must have patience and tact in creating and maintaining rapport between himself and the source, thereby enhancing the success of the interrogation. The validity of the source's statements and motives behind these statements may be obtainable only through exercise of tact and patience. Displaying impatience may—

- Encourage the difficult source to think if he remains unresponsive for a little longer, the interrogator will stop questioning.
- Cause the source to lose respect for the interrogator, thereby reducing his effectiveness.

An interrogator, with patience and tact, is able to terminate an interrogation and later continue it without arousing apprehension or resentment.

CREDIBILITY

The interrogator must maintain credibility with the source and friendly forces. Failure to produce material

rewards when promised may adversely affect future interrogations. The importance of accurate reporting cannot be overstressed, since interrogation reports are often the basis for tactical decisions and operations.

OBJECTIVITY

The interrogator must maintain an objective and dispassionate attitude, regardless of the emotional reactions he may actually experience or simulate during the interrogation. Without objectivity, he may unconsciously distort the information acquired. He may also be unable to vary his interrogation techniques effectively.

SELF-CONTROL

The interrogator must have exceptional self-control to avoid displays of genuine anger, irritation, sympathy, or weariness which may cause him to lose the initiative during the interrogation. Self-control is especially important when employing interrogation techniques which require the display of simulated emotions or attitudes.

ADAPTABILITY

An interrogator must adapt to the many and varied personalities which he will encounter. He should try to imagine himself in the source's position. By being adaptable, he can smoothly shift his techniques and approaches during interrogations according to the operational environment. In many cases, he has to conduct interrogations under unfavorable physical conditions.

PERSEVERANCE

A tenacity of purpose can be the difference between an interrogator who is merely good and one who is superior. An interrogator who becomes easily discouraged by opposition, noncooperation, or other difficulties will neither aggressively pursue the objective to a successful conclusion nor seek leads to other valuable information.

APPEARANCE AND DEMEANOR

The interrogator's personal appearance may greatly influence the conduct of the interrogation and attitude of the source toward the interrogator. Usually a neat, organized, and professional appearance will favorably influence the source. A firm, deliberate, and businesslike manner of speech and attitude may create a proper environment for a successful interrogation. If the interrogator's manner reflects fairness, strength, and efficiency, the source may prove cooperative and more receptive to questioning.

FM 34-52

However, depending on the approach techniques (see Chapter 3), the interrogator can deliberately portray a different (for example, casual or sloven) appearance and demeanor to obtain the cooperation of the source.

INITIATIVE

Achieving and maintaining the initiative are essential to a successful interrogation just as the offense is the key to success in combat operations. The interrogator must grasp the initiative and maintain it throughout the interrogation.

SPECIAL AREAS OF KNOWLEDGE

The interrogator must be knowledgeable on a variety of subjects in order to be effective in exploiting sources. Some of these areas are—

- Proficiency in the target language.
- Knowledge of the target country.
- International agreements.
- Enemy materiel and equipment.
- Armed forces uniforms.
- OB information.

In addition to these subjects, the interrogator should have a knowledge of basic psychology and neurolinguistics.

PROFICIENCY IN THE TARGET LANGUAGE

The interrogator must be proficient in one or more foreign languages to exploit both human sources and CEDs. According to the GPW, a prisoner must be questioned in a language he understands.

The more proficient an interrogator is with the target language, the better he will be able to develop rapport with his source, understand the nuances of the source's speech, and follow up on source leads to additional information.

The skilled linguist will be able to translate CEDs quicker and more accurately than the interrogator who is merely familiar with the target language.

KNOWLEDGE OF THE TARGET COUNTRY

The interrogator should be familiar with the social, political, and economic institutions; geography; history; language; and culture of the target country. Since many sources will readily discuss nonmilitary topics, the interrogator—

The source, especially if detained by military forces during tactical operations, normally has undergone a traumatic experience and fears for his life. This anxiety is usually intensified by the source's lack of knowledge and understanding of what is about to occur (fear of the unknown), or by the unfounded fear he will be tortured or executed.

The interrogator has a position of authority over the source. The source realizes this fact, and, in some cases, believes his future might depend upon his association with the interrogator.

- May induce reluctant prisoners to talk by discussing the geography, economics, or politics of the target country.
- May gradually introduce significant topics into the discussion to gain insight about the conditions and attitudes in the target country.
- Should keep abreast of major and current events as they occur in the target country to better understand the general situation, as well as causes and repercussions.

LAW OF WAR

The interrogator should understand US law of war obligations contained in the GWS, GPW, and GC regarding the treatment of EPWs, retained personnel, and civilian internees (see Figure 1-4).

ENEMY MATERIEL AND EQUIPMENT

The interrogator should be familiar with the capabilities, limitations, and employment of standard weapons and equipment so he may recognize and identify changes, revisions, and innovations. Some of the more common subjects of interest to the interrogator include the following:

- Small arms.
- Infantry support weapons.
- Artillery.
- Aircraft.
- Vehicles.
- Communications equipment.
- NBC defense.

ARMED FORCES UNIFORMS AND INSIGNIA

Through his knowledge of uniforms, insignia, decorations, and other distinctive devices, the interrogator may be able to determine the rank, branch of service, type of unit, and military experience of a military or paramilitary source. This knowledge is helpful during the planning and preparation and the approach phases discussed in Chapter 3.

OB INFORMATION

OB is defined as the identification, strength, command structure, and disposition of personnel, units, and equipment of any military force. Interrogation OB elements are separate categories by which detailed information is maintained. They are—

- Missions.
- Composition.
- Disposition.
- Strength.
- Training.
- Combat effectiveness.
- Tactics.
- Logistics.
- Electronic technical data.
- Miscellaneous data.

During the questioning phase, OB elements assist the interrogator in verifying the accuracy of the information obtained and can be used as an effective tool to gain

INTERROGATOR CAPABILITIES AND LIMITATIONS

HUMINT collection is capable of obtaining information pertinent to all six IEW tasks:

- Situation development.
- Target development and target acquisition.
- I&W.
- IPB.
- BDA.
- Force protection.

Interrogators are trained as linguists to question EPWs and civilian detainees and to exploit CEDs.

new information. Aids which may be used to identify units are—

- Names.
- Commanders.
- Home station identifications.
- Code designations and numbers.
- Uniforms and insignia.
- Guidons.
- Documents.
- Military postal system data.
- Equipment and vehicle markings.

UNDERSTANDING BASIC PSYCHOLOGY

An interrogator can best adapt himself to the EPW's or detainee's personality and control of their reactions when he understands basic psychological factors, traits, attitudes, drives, motivations, and inhibitions. For example, the timely use or promise of rewards and incentives may mean the difference between an interrogation's success or failure and future EPW or detainee exploitation.

NEUROLINGUISTICS

Neurolinguistics is a behavioral communication model and a set of procedures that improve communication skills. The interrogator should read and react to nonverbal communications. An interrogator can best adapt himself to the source's personality and control his own reactions when he understands basic psychological factors, traits, attitudes, drives, motivations, and inhibitions.

During their collection, interrogators attempt to obtain and report any information possessed by these targets that pertains to the IEW tasks. This persistence is determined by comparing the information obtained to the SIR contained in the interrogation element's collection mission.

Interrogators are capable of collecting information on political, economic, and a wide range of military topics. For the most part, interrogators attempt to organize their collection effort according to the OB elements analysts use. In addition to these elements, interrogators also obtain PIR-directed information on the

FM 34-52

missions assigned to enemy units. Appendix B discusses relevant questioning guides.

ENVIRONMENTAL CONSIDERATIONS

The environment in which interrogation operations are performed affects the degree of success achieved. There are primarily two areas, both having limitations, upon which the interrogators depend:

- The IEW process which gives direction and purpose to their collection efforts.
- The conduct of combat operations which provides them with collection targets; that is, EPWs, detainees, and CEDs.

If the IEW process or combat operations are not ideal, use what you can to capitalize on capabilities.

IEW Process

The IEW process can limit interrogators by assigning collection missions which are not suited to HUMINT collection capabilities; as well as by not disseminating copies of the following reports:

- Intelligence summary (INTSUM).
- Intelligence report (INTREP).
- Daily intelligence summary (DISUM).

CONFLICTS

HICs are conflicts between two or more nations and their respective allies, where the belligerents employ modern technology complemented by intelligence; mobility; firepower (to include NBC weapons); service support; and C³ resources.

MICs are conflicts between two or more nations and their respective allies, where the belligerents employ modern technology complemented by intelligence; mobility; firepower (without NBC); C³; and service support resources for limited objectives under definitive policy limiting employment of destructive power and geography involved.

LICs are political-military confrontations between contending states or groups below conventional war and above the routine, peaceful competition among states. They—

- Frequently involve protracted struggles of competing principles and ideologies.
- Range from subversion to the use of armed force.

- Periodic intelligence report (PERINTREP).
- Supplementary intelligence report (SUPINTREP).
- Other intelligence reports.

Combat Operations

Combat operations can limit interrogators by—

- Delaying evacuation of EPWs or detainees and captured documents, thereby limiting time available to exploit them.
- Allowing prisoners and documents to be mishandled, thereby decreasing their exploitation potential.
- Not providing the equipment, supplies, and secure communications needed for successful operations.

INHERENT LIMITATIONS

Interrogation operations are also limited by the very nature of HUMINT collection. EPWs or detainees and CEDs must actually have the desired information before interrogators can collect it. With EPWs or detainees, there is always the possibility knowledgeable individuals may refuse to cooperate.

The UCMJ, GWS, GPW, and GC set definite limits on measures which can be taken to induce an EPW or detainee to cooperate.

- Are waged by combining and employing political, economic, informational, and military instruments.
- Are often localized, generally in the Third World, but contain regional and global security implications.

LIC operational intelligence requirements are HUMINT intensive and demand detailed familiarity with the military, political, and front organizations of the insurgent enemy, and the environment in which he operates.

The interrogator's familiarity with the areas of operations (AOs) must include an understanding of the insurgency, its objectives, history, successes, and failures. This understanding is required not only on a general countrywide basis but also on an expanded basis within the interrogator's particular AO. Therefore, it is essential the interrogator grasps the importance the insurgent organization places on accomplishing political objectives as opposed to military successes.

One measure of the interrogator's effectiveness is his ability to apply appropriate interrogation techniques to the personality of the source. Interrogations associated with LIC operations dictate the need for skill in the full range of interrogation techniques so the interrogator can conduct the many types of interrogations demanded.

Warfighting doctrine IEW principles apply for LIC; however, intelligence indicators for insurgent activity are unique. Anything insurgents can do to influence and direct a society toward overthrowing its government is reflected by some action or indication, no matter how subtle. Some MI advisors may be required to assist paramilitary and nonmilitary elements in developing HUMINT sources and exploiting their information.

As US forces are committed to the LIC operation, interrogation support will more closely adhere to the traditional tactical environment. Typical LIC missions are—

- Counterinsurgency and insurgency support.
- Combatting terrorism.
- Peacekeeping and peacetime contingency operations.

HUMINT is a major LIC source because of the necessity to exploit the local populace and to know and understand enemy intentions. In LIC, interrogators exploit EPWs and CEDs. For example, in addition to conducting EPW operations at collecting points, interrogators may participate in cordon and search and roadblock operations, tactical check points, and low-level collection missions in conjunction with the supporting CI unit (see FM 34-60A(S)). Interrogators may also provide support to drug and law enforcement agency (DLEA) operations.

INTERROGATION MISSIONS

Interrogators perform various types of missions. As discussed previously, the two main missions are personnel and document exploitation. There are other functions for which interrogators are ideally suited because of their language and HUMINT training. These include—

- Linguist support to hostage negotiations, counterdrug, and special operation forces (SOF) operations.

- LLSO linguist support.
- Psychological operations (PSYOP) linguist support.
- Civil Affairs (CA) linguist support.
- Treaty verification and observer duties.

DRUG AND LAW ENFORCEMENT AGENCY OPERATIONS

Army interrogators may assist Federal law enforcement authorities and, where lives are endangered, state and local law enforcement authorities, after concurrence by the Army General Counsel and approval by the Secretary of Defense or his designee. (See AR 381-10, Procedure 12, and AR 500-51.)

Army interrogators may assist law enforcement agencies and security services or foreign governments or international organizations only in accordance with applicable law and policy, including any status of forces

agreements. Such assistance will ordinarily constitute security assistance, which must be approved in accordance with AR 12-15.

Under no circumstances will interrogators assist any law enforcement authorities in any manner without prior approval by competent authority after a legal review of the proposal.

CHAPTER 2 COMPOSITION AND STRUCTURE

The interrogation architecture (interrogators and interrogation units) is a seamless system that supports operations from brigade to theater level. The dynamic warfighting doctrine requires interrogation units be highly mobile and have automation and communication equipment to report information to the supported commander.

Regardless of their employment level, interrogation units should be equipped with state-of-the-art automation equipment, necessary HUMINT software, and dedicated and secure communication equipment with skip echelon, digital, voice, facsimile, and optical scanning capability. This equipment enables interrogators to—

- Receive data base information.
- Manipulate that information.
- Incorporate it into their operational data bases.
- Produce tactical information reports.

By using secure communication equipment, interrogators are able to disseminate time-sensitive information to the supported commander as answers to his PIR which facilitates decision-making. The Prisoner of War

Information System (PWIS) is a databased system maintained by the provost marshal's office at theater level. It has the capability to recall an EPW's evacuation audit trail.

This prisoner of war interrogation (IPW) communication and automation system facilitates transmission of EPW-derived information from brigade to theater; it precludes duplicated effort in EPW or CED exploitation.

The MI unit commander must ensure interrogators have the necessary equipment to accomplish their wartime mission. The MI unit commander retains overall responsibility for interrogators assigned to his unit. The manner in which these interrogators are controlled depends on how the MI unit is task organized for combat.

If interrogators are deployed in general support (GS) of the division, the MI battalion commander exercises control over them through his S3 and the battalion tactical operations center (TOC). If interrogators are deployed in direct support (DS) of a division's subordinate units, they are tasked by the commanders of those units through their S2s.

TACTICAL OPERATIONS CENTER

Normally, interrogators are a primary source of OB information. The interrogation element chief should ensure that he or someone appointed to this duty has daily personal contact with the division or corps collection management and dissemination (CM&D) section at the TOC. During these visits, all questions and information pertaining to OB and intelligence target priority lists can be discussed and later disseminated to various interrogators.

Interrogator elements must receive all reports and findings made by analysts; in turn, all interrogation reports should reach analysts. Direct contact must be maintained between these two elements, preferably in person or by telephone. This ensures access to important information which may arise between liaison visits.

TASKING RELATIONSHIPS

When interrogators are task-organized under the IEW company, the team leader directs the tasking. The

DS and GS teams are under operational control (OPCON) to the IEW company when they are supporting that company. The officers responsible for tasking interrogation elements ensure the following steps are accomplished:

- Collection missions that reflect the capabilities and limitations of interrogators are assigned.
- INTREPs are integrated with information provided by other collectors during the IPB process.
- Copies of the INTSUM, INTREP, PERINTREP, DISUM, and SUPINTREP are disseminated to the interrogation element as they are published.
- Close contact is maintained with the interrogation element.

FM 34-52

INTERROGATOR TASK ORGANIZATIONS

Interrogators are not assigned by tables of organization and equipment (TOE) to units below division. However, MI parent units often task interrogators and place them in DS to brigades. For example, in a light division, there are usually enough interrogators assigned to send forward deployed interrogation teams, known as "GO" teams, to the brigades to complement light division operations.

EPW interrogation may be desirable at all echelons, but is not practicable due to limited numbers of interrogators available. As a minimum, there should be an interrogation element at the division central collection point, corps holding areas, and theater internment facility.

Interrogation elements at all echelons are task organized, and may not mirror the TOE organization in their parent unit.

DEPLOYMENT SITES

Interrogation assets are mobile enough to be shifted in response to new developments. The initial deployment of these assets are guided by the exploitation priority established by the commander. Operations are conducted at an echelon that will allow interrogators the best opportunity to satisfy their assigned collection mission. The areas discussed below should be considered when making the deployment decisions.

Number of Interrogators Available

The number of interrogators available limit the number of deployment sites that can be used. MI commanders at corps consider how many interrogators will be available for interrogation operations after augmentation has been provided to subordinate divisions. The number of interrogators also play a key role in deciding the level of intense or sustained collection operations they can conduct.

INTERROGATION BELOW DIVISION

The first interrogation could take place at brigade. Interrogation teams are attached temporarily to brigades in enemy contact when determined appropriate by the division G2. These teams come from the interrogation section of the parent division. Interrogation personnel are organic to separate brigades and armored cavalry regiments (ACRs). Interrogation at brigade level is strictly tactical and deals with information of immediate value.

Type and Intensity of Combat Operations

Intense collection employs all available interrogators with little or no provision for them to rest. The major disadvantage of intense collection is these interrogators become exhausted quickly. Interrogations amount to prolonged conversations under extreme stress. Once the available interrogators are exhausted, collection stops until they recover or additional assets arrive.

A severe decrease in interrogation effectiveness can be expected between 12 and 18 hours after the onset of intense collection, with 18 hours as the maximum time possible for intense collection. This kind of all-out effort can be justified when critical information must be obtained or confirmed quickly to forestall a major disaster. Similar problems can be expected during intense CED exploitation.

Sustained operations can be maintained indefinitely. They also allow the commander some rested interrogators to use on a contingency basis in a different location. Disadvantages of sustained collection are fewer sources are exploited over a given time and operations are slower.

Support Available

In making deployment decisions, the area where operations are to be conducted must provide the support required by the interrogation element. This support includes—

- MP coordination.
- Priority access to reliable means of secure communications.
- Adequate shelter and security.
- A flow of CEDs and sources to exploit.

Other information the EPW might possess is developed at higher levels. At brigade, the scope of interrogation changes from hour-to-hour as the tactical situation develops. These interrogations must be geared to cope with any tactical possibility at a moment's notice.

Interrogation personnel in DS to brigade will be collocated or immediately adjacent to the division forward EPW collecting point in the brigade support area

(BSA). For MI units to receive S2 support, the collecting point and interrogation site will be collocated and accessible to the command post (CP).

DIVISION INTERROGATION ASSETS

An MI battalion is organic to each division. It provides combat intelligence, EW, and OPSEC support to light or heavy infantry and airborne or air assault divisions.

The MI battalion provides special support the G2 needs to produce combat intelligence. Interrogation personnel organic to the MI battalions compose the interrogation support element.

The intelligence and surveillance (I&S) company provides division CI, interrogation, and surveillance support.

The I&S company interrogation team manages the division's interrogation assets, including those interrogation teams attached from corps. Additional team duties are—

- Screen CEDs.
- Provide interpreter and translator support.
- Liaison with PSYOP and G5 personnel.

ORGANIZATION (LIGHT DIVISION)

In a light division, interrogators belong to the I&S Company, MI Battalion. Figure 2-1 shows this structure. Light division MI battalions have 25 interrogators subordinate to the I&S company. Two 5-man DS teams in the interrogation platoon ensure the platoon can provide support to two committed brigades.

Platoon Headquarters

Platoon headquarters provides C³ for the interrogation element. It consists of a platoon leader and sergeant. The platoon headquarters coordinates with—

- I&S company commander for personnel status, administrative support, and logistical support prior to deployment to the division support area (DSA).
- MI battalion S3 for intelligence tasking and deployment of interrogation assets.
- Division G2 for reporting, enemy situation updates, and PIR, IR, and SIR.
- DISCOM commander for DSA logistical and communications support, and interrogation element location in the DSA.

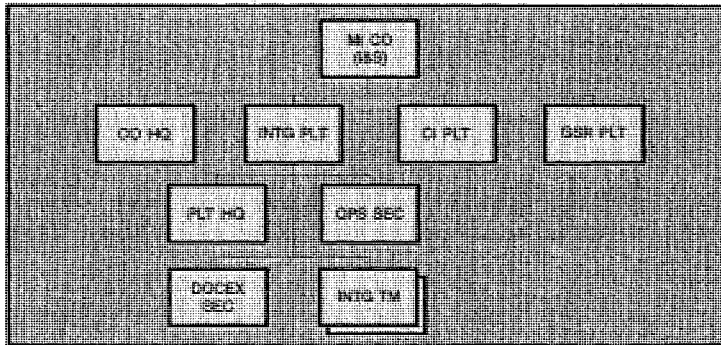

Figure 2-1. MI Company (I&S), MI Battalion, Light Division.

FM 34-52

- MP company commander for division central EPW collecting point location, and EPW processing and evacuation procedures.
- Medical battalion commander for procedures to treat and clear wounded EPW for questioning.
- CI platoon leader for requirements and joint CI and interrogation procedures.
- MI company team leaders for deployment of DS interrogation teams.
- CA and PSYOP elements for requirements and processing of civilian detainees and refugees.

Operations Section

This consists of a section chief (warrant officer), non-commissioned officer in charge (NCOIC), and two 4-member interrogation teams. The operations section chief manages the interrogation effort to ensure interrogations respond to division intelligence requirements.

DOCEX Section

This consists of a section chief (warrant officer) and three document examiners. The DOCEX section may be used as an additional interrogation team when

priority of exploitation and EPW capture rate dictate. The division G2 determines whether interrogation or document examination will have priority.

When three brigades are committed in an operation, the DOCEX section may be employed as a third brigade level team.

DOCEX assets may also function in an interrogation role when the number of EPWs at the division central collecting point requires additional division level interrogators or when the CED rate is very low.

Interrogation Teams

Each interrogation team consists of a team leader (warrant officer), NCO assistant team leader, and three team members. Teams are normally employed as part of the MI company teams which provide IEW support to the brigades.

ORGANIZATION (HEAVY DIVISION)

In a heavy division, interrogators are assigned to the I&S Company, MI Battalion. Figure 2-2 shows this structure.

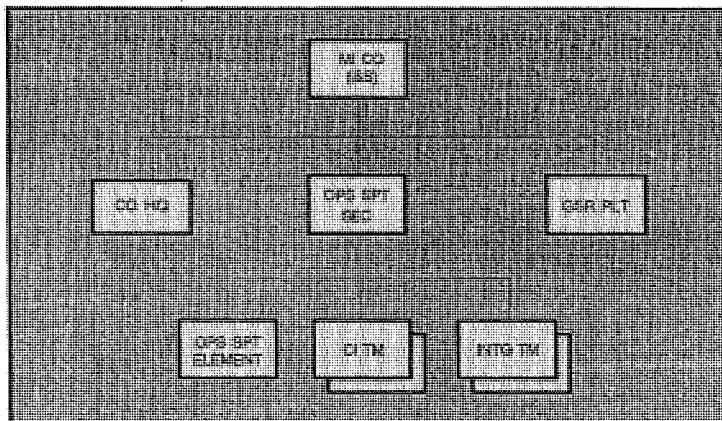

Figure 2-2. I&S Company, MI Battalion, Heavy Division.

ORGANIZATION (AIRBORNE OR AIR ASSAULT DIVISION)

In an airborne or air assault division, interrogators are assigned to the I&S Company, MI Battalion. Figure 2-3 shows this structure.

ORGANIZATION (ACR AND SEPARATE BRIGADE)

In an ACR or separate brigade, interrogators are assigned to the operations support platoon of the MI company. Figure 2-4 shows this organization.

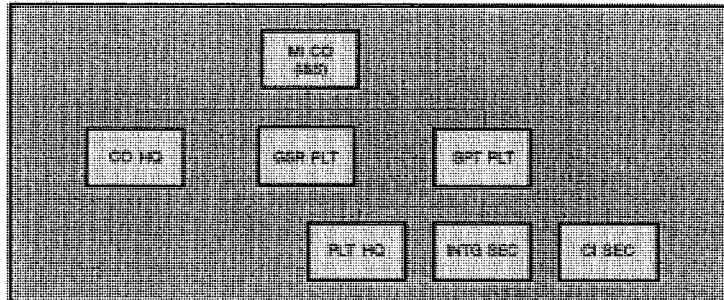

Figure 2-3. I&S Company, MI Battalion, Airborne or Air Assault Division.

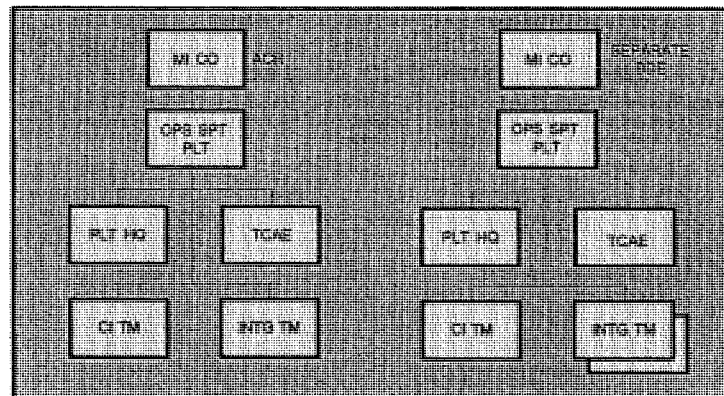

Figure 2-4. MI Company Operations Support Platoon for ACR and Separate Brigade.

FM 34-52

SPECIAL FORCES GROUP

In a Special Forces Group (Airborne) (SFGA), interrogators are assigned to the Military Intelligence Detachment (MID). Figure 2-5 shows this structure.

Interrogation teams may be combined with the CI section when not conducting interrogation operations.

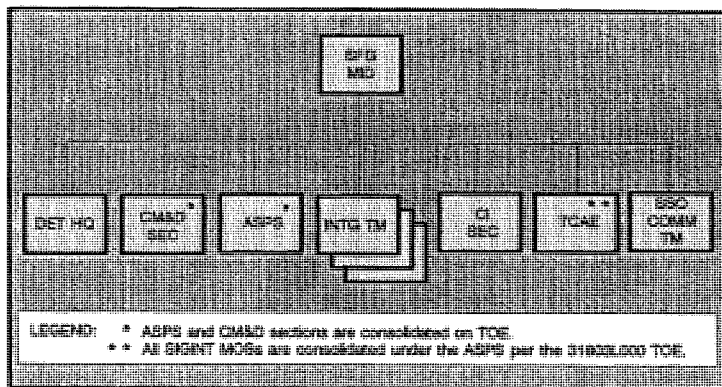

Figure 2-5. Organization, MI Detachment, Support Company, Special Forces Group.

CORPS INTERROGATION ASSETS AND ORGANIZATION

At corps, interrogators are assigned to the MI Battalion (Tactical Exploitation) (TE). Figure 2-6 shows this structure. The CI interrogation company consists

of a company headquarters, IPW and CI operation sections, CI and interrogation platoons, and a maintenance section.

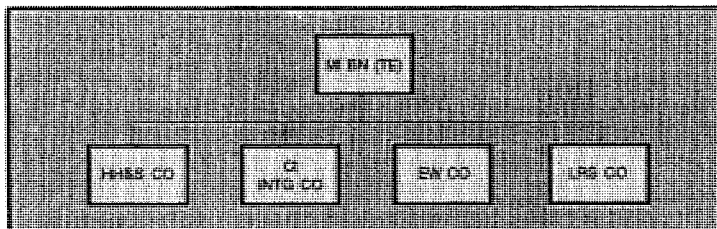

Figure 2-6. MI Battalion (TE).

The CI platoon has nine teams and the interrogation platoon normally has eight teams. Interrogators can be placed in a DS role to divisions to augment division interrogation assets.

terrogation company. Figure 2-7 shows this structure.

The corps also has a Reserve Components (RC) MI Battalion (TE), which has a subordinate CI in-

There are also linguist battalions which augment and support Active Component (AC) units in time of hostilities.

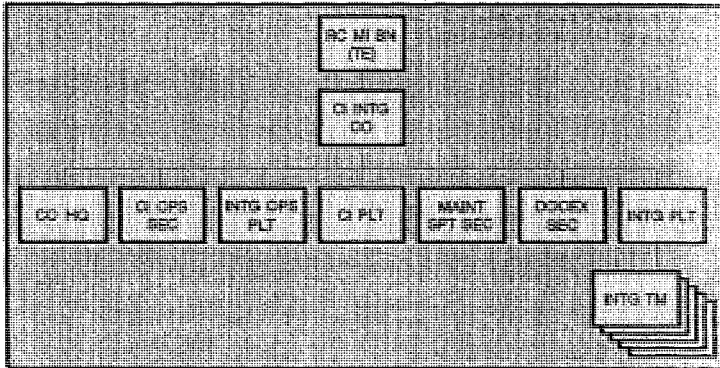

Figure 2-7. RC MI Battalion (TE) Corps.

ECHELONS ABOVE CORPS INTERROGATION ASSETS AND ORGANIZATION

The MI Battalion (Collection and Exploitation [C&E]), as shown at Figure 2-8, has a headquarters and

headquarters company (HHC), MI Company (CI), and MI Company (Interrogation and Exploitation) [I&E]).

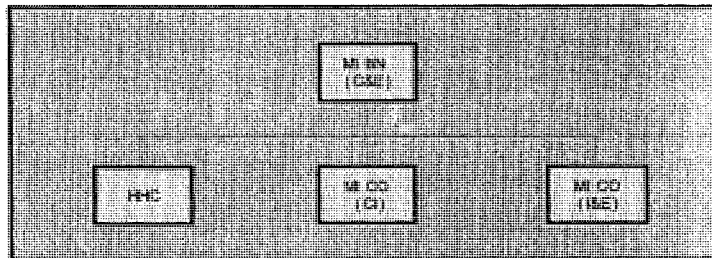

Figure 2-8. MI Battalion (C&E), MI Brigade (EAC).

FM 34-52

The MI Battalion (I&E), as shown at Figure 2-9, has an HHC and three MI companies (I&E), of which one is GS. Two MI companies (I&E) (INTG) operate the theater, joint, or combined interrogation facilities, while the MI company (I&E) (GS) is for GS to echelons corps and below (ECB).

section, food service section, and an I&E platoon, consisting of two sections.

The MI company (I&E) (GS), MI Battalion (I&E), has a headquarters section, an operations section, and three interrogation platoons, each with a platoon headquarters and eight sections. Figure 2-11 shows this structure.

The MI Company (Interrogation) of the MI Battalion (C&E) and (I&E), as shown at Figure 2-10, has a company headquarters, operations section, communications

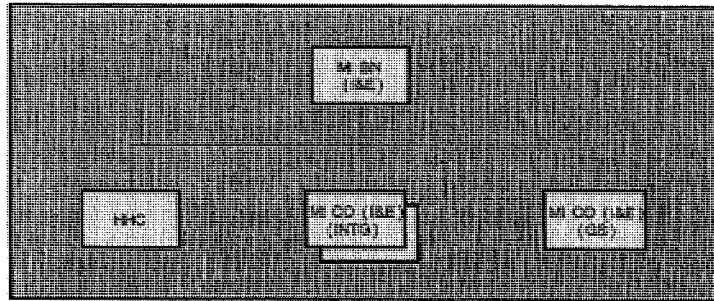

Figure 2-9. MI Battalion (I&E), MI Brigade (EAC).

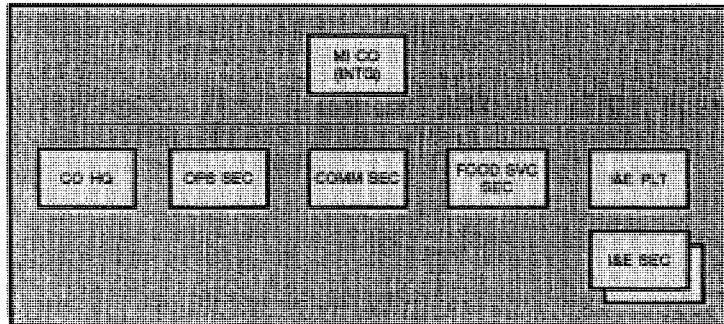

Figure 2-10. MI Company (INTG), MI Battalion (C&E) and (I&E).

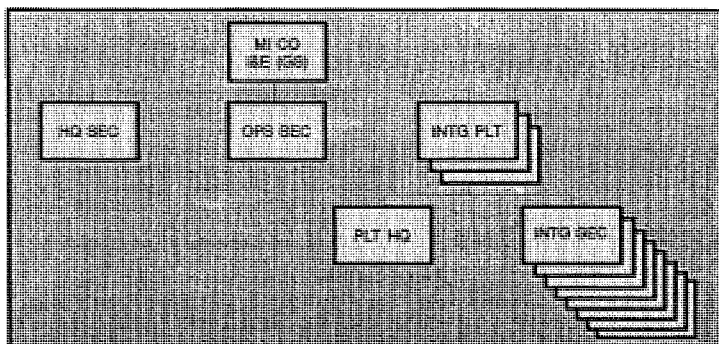

Figure 2-11. MI Company (I&E) (GS), MI Battalion (I&E).

ENEMY PRISONER OF WAR AND INTERROGATION FACILITIES

There are significant differences in EPW and interrogation facilities at each echelon; this is due to the numbers of EPWs, the missions of the various echelons, and the size of the interrogation elements.

EVACUATION AND GUARDING EPW

Initially, the capturing unit is responsible for evacuating and guarding EPWs. In brigade-size operations, battalions evacuate prisoners to brigade collecting points as the situation permits. In most cases, EPWs are evacuated rapidly using backhaul transportation from brigade collecting points to departure areas because they require food and guards, both of which are in short supply at brigade. EPW collecting points should be located close to supply routes to speed evacuation.

BRIGADE AND LOWER ECHELONS

At brigade level, EPWs can be detained in open fields, courtyards, gardens, jungle clearings, or similar sites if they are hidden from enemy observation. If necessary, these areas can be enclosed with barbed wire for more efficient EPW handling. Because EPWs seldom remain at a forward collecting point for more than a few hours, EPWs are not usually kept in a building or other shelter.

Interrogation facilities at battalion and brigade are kept to a minimum. Brigade interrogation personnel should be located adjacent to the brigade forward EPW collecting point in the BSA. The collecting point

should be out of sight and sound of other BSA activities. It should be close to normal evacuation routes.

The distance between the collecting point and CP is important. When possible, the collecting point and interrogation site should be within walking distance or a few minute's driving distance of the CP.

Interrogators with battalions or brigades should have vehicles equipped with radios for rapid communication with their respective intelligence officers and other intelligence agencies.

DIVISION FACILITIES

The principal EPW tactical interrogation takes place at division. While the procedure is similar to that used at brigade, the interrogation scope is broader.

Previous interrogation reports received from brigade are reviewed. This information is expanded by further interrogations for tactical information to include all OB elements.

The interrogators at division level will prepare and disseminate summary interrogation reports. As dictated by the tactical situation, the interrogation facility at division may be augmented by corps interrogation personnel.

The division's central EPW collecting point is operated by division MP under the supervision of the division provost marshal. The interrogation section should be located immediately adjacent to the division's

FM 34-52

central EPW collecting point, normally along the main supply route (MSR) within or near the division support command (DISCOM).

The distance between the interrogation facility and G2 section (rear) is not as critical as at brigade level. Personal liaison between the interrogation and intelligence sections, although important, may not be required as frequently as at brigade.

At division, the G2 directs interrogation section collection efforts in conjunction with the CM&D section

and the MI battalion commander, who serves as one of his principal assistants.

Compared to brigade facilities, division interrogation facilities are expanded. This is because the division interrogation section handles and interrogates more captured personnel, and interrogations are conducted in greater detail. When practicable, interrogations at division should be conducted in improvised interrogation rooms in buildings adjacent to the division collecting point. If possible, separate rooms should be available to permit several interrogations at once.

CORPS FACILITIES

The corps EPW holding area is established and operated by MP under the supervision of the corps provost marshal. The Corps Interrogation Facility (CIF) will usually be a more permanent type facility than at echelons below corps. It should consist of

operations and interrogation areas with separate, enclosed interrogation booths or rooms. If possible, there should be a separate DOCEX area. Figure 2-12 shows a sample CIF.

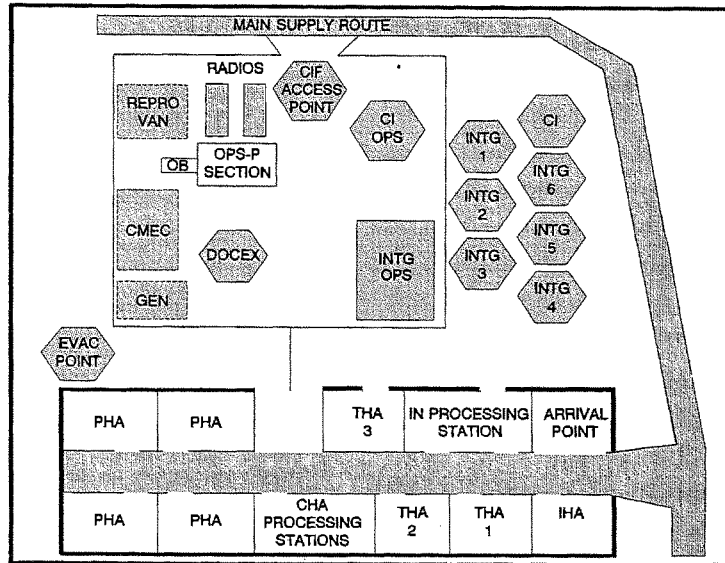

Figure 2-12. Sample Corps Interrogation facility (CIF).

The commander, CI Interrogation Company, MI Battalion (TE), MI Brigade (Corps), is the CIF commander. CIFs are the principal establishment for the exploitation of captured personnel and CEDs. Functions of the centers include—

- Conducting tactical and strategic interrogations based on the intelligence requirements and specific guidance of the corps G2 section.
- Screening to select sources suited for further exploitation at a higher echelon interrogation center.
- Screening of EPW and other sources of specific CI interest.
- Interrogating sources of interest to PSYOP intelligence based on their requirements.
- Preparing and disseminating interrogation reports.

Continuous coordination between the CIF commander and EPW holding area commander is essential. At a sub-level, it is also important for interrogators to maintain a good working relationship with MP at the holding area.

MP, who are in constant contact with EPWs or detainees, can provide interrogators valuable information on individual sources. By properly handling prisoners at all times, they also contribute to the success of interrogation operations by helping to reduce resistance by the sources.

The CIF should be administratively and operationally self-sufficient and located within or adjacent to the EPW holding area, close enough to facilitate operations.

ADEQUATE INTERROGATION FACILITIES

At corps level, particular emphasis should be placed on providing facilities adequate for the interrogation of EPWs of higher positions or rank. Because interrogations will normally last longer than at division, a greater degree of comfort should be provided, if possible. In other respects, the type of interrogation facilities and equipment parallels those found at division.

OB SECTION

OB analysts are a valuable interrogation facility asset. They ensure PIR, IR, and SIR are updated, and reporting is in response to them. In addition, they maintain a situation map (SITMAP) and OB updates to keep interrogators current on tactical situations.

EDITORIAL PERSONNEL

The senior interrogator may assign interrogators to edit INTREPs. They also may use the organizational chain of command to ensure quality control of reporting. When OB analysts are available, the commander may task them to edit reports.

DOCEX SECTION

The DOCEX section receives documents taken from captured personnel, battlefield casualties, and positions abandoned by the enemy. It processes captured documents; for example, screens for intelligence value, categorizes, and translates. It forwards translation reports on information of immediate tactical value. (Chapter 4 describes document categories.)

SPECIALIZED INFORMATION

The scope of interrogations at corps is widened by the commander's intelligence requirements, SIR of the numerous technical service staff agencies, and other intelligence agencies and services. All such special needs for information are coordinated by the corps G2 section. Interrogators must be aware of these overall intelligence requirements to adequately exploit captured personnel.

Because of the range of specialized information required, interrogation at corps level should be conducted by interrogators who specialize in fields such as armor, engineering, medicine, and other specialized subject areas.

To extract detailed EPW information, the senior interrogator will assign some interrogators as screeners and others to specialized areas. However, he must coordinate, for example, with technical intelligence (TECHINT) assets. This is to prevent duplication or gaps in information obtained.

Continuous coordination is required between all echelon interrogators to ensure a smoothly functioning operation.

The corps MI brigade applies the technical expertise, intelligence manpower, and equipment needed by G2 to produce integrated combat intelligence. The corps commander has OPCON, while the G2 has staff supervision over the MI brigade.

FM 34-52

ECHELONS ABOVE CORPS FACILITIES

At echelons above corps (EAC), the MI company (I&E), MI battalion (C&E) or (I&E), MI brigade (EAC), will form the Theater Interrogation Facility (TIF). The TIF, which is commanded by an MI captain, provides interrogation support to the theater or joint command and to national level intelligence agencies. The TIF will—

- Be located within the main theater EPW internment facility.
- Be tailored organizationally to meet requirements of the theater and situation.
- Include interrogators, CI personnel, and intelligence analysts from the Army, Air Force, Marine Corps, and, in some cases, the Navy.
- Be organized similarly to the CIF; that is, by function.

- Have intelligence analysts to handle requirements and keep interrogators informed of changes in the operational or strategic situation.
- Maintain the capability to deploy "GO" teams to multiple theater EPW camps, as well as to forward deploy them to corps and ECB as needed.
- Provide experienced senior interrogation warrant officers and NCOs who are graduates of the Department of Defense (DOD) Strategic Debriefing Course (additional skill identifier 9N or N7) and physical plant for the Joint Debriefing Center (JDC), where exploitation of high-level (Category A) sources takes place on operational and strategic topics.

MEDICAL COMPANY INTERROGATIONS

Sometimes it may be advantageous to conduct interrogations at the medical company. Wounded prisoners being evacuated through medical channels are frequently valuable sources of information; however, interrogators cannot represent themselves as medical or Red Cross personnel.

The fact the EPW is wounded, and in an "enemy" hospital, puts him in a state of mind conducive to interrogation. The permission of competent medical authority is required before wounded prisoners can be interrogated.

US Army doctors and medics are considered competent medical authorities. In their absence, the interrogation may not commence, even upon direction of nonmedical military authority.

When interrogating a sick or wounded EPW, great care must be taken to avoid implying that treatment will be withheld if cooperation is denied. The interrogation process must not interfere with timely medical treatment, to include administering medication to relieve pain.

INTERROGATION AT BRIGADE AND BELOW

Interrogators are not usually attached below brigade level unless the combat situation requires limited tactical interrogation at battalion or lower. In this event, skilled interrogators from the MI battalion will be attached temporarily to committed battalions. They will assist in exploiting EPW immediately upon capture to extract information needed in support of the capturing unit.

Interrogations at battalion or lower are brief and concerned only with information bearing directly on the combat mission of the capturing unit. The following are examples of circumstances warranting an interrogation:

- A unit or landing force assigned an independent mission in which the S2 is primarily responsible for

collecting information necessary to fulfill the unit's mission. Immediate tactical intelligence is necessary for mission accomplishment.

- There is a definite need for interrogation at a lower level to permit rapid reaction based on information obtained.
- It is advantageous to have an EPW point out enemy defenses and installation from observation points in forward areas.

BATTALION S2 CONTROLS

Interrogators employed for temporary periods at battalion level receive FIR, IR, and SIR from the sup-

ported battalion S2. This will ensure interrogators are fully oriented to the battalion's collection mission.

In other instances, interrogators may be placed at brigade in an "on-call" status, from which they can proceed to any of the subordinate battalions as circumstances warrant. Upon completion of a low-level, immediate-type interrogation, they can return to brigade and again become available for immediate employment.

Commanders and S2s below brigade level who are unable to obtain interrogator support from higher echelons should include provisions in unit and staff standing operating procedures (SOPs) for the "tactical questioning" (not interrogation) of EPWs or detainees. They should identify assigned personnel for language capability.

Interrogation personnel should provide training in the area of tactical questioning to designated S2 personnel. The potential for abuse of the EPW is greatest at the initial capture and tactical questioning phase. With the excitement and stress of the battlefield, it may become easy for unskilled personnel to resort to illegal techniques to elicit critical information.

Your instruction must stress the importance of the proper treatment of EPWs. Emphasize that the abuse of an EPW at the initial stage of contact often renders future interrogation futile.

If you are engaged in, or supervising the tactical questioning of EPWs, you are responsible for ensuring that EPWs are treated in accordance with the requirements of international and US law. Any tactical questioning conducted must be in response to the supported commander's PIR. Appendix C discusses S2 tactical questioning.

At this level the brigade S2 must maintain secure communication with interrogation personnel to ensure requirements are answered. Except under extreme weather conditions, and MP availability, it is not necessary to keep EPWs within the confines of a building or other shelter at battalion level since they will not remain for more than a few hours before being evacuated.

The capturing unit escorts or transports EPWs or detainees to the nearest collecting point, and turns them over to the MP. Interrogators in DS of the brigade will screen and categorize all EPWs or detainees, question them, and report information obtained in response to brigade PIR, IR, and SIR. They will do this under time constraints, as all EPWs or detainees must be evacuated without delay.

In spite of the temporary nature of the forward EPW collecting point, interrogators should maintain enough space between the collecting point and the interrogation site to ensure the privacy of interrogations. EPWs or detainees should not be able to observe or hear interrogations in progress.

INTERROGATIONS IN OTHER OPERATIONS

The functions and basic operational techniques employed by the interrogation element attached to the infantry division apply to interrogation elements supporting armored, amphibious, and airborne operations in any terrain or climate.

Differences arise primarily in the planning stages and interrogation objectives. These differences normally result from the inherent characteristics of each type of unit and terrain and climate involved.

For example, the interrogator engaging in airborne and amphibious operations will be dependent upon intelligence support from higher agencies during the planning stage. This is necessary because the unit does not have actual contact with the enemy until a specific operation begins.

Once H-hour arrives, the interrogator will be faced with a rapidly developing and changing tactical situation. At this time, the degree of success correlates to the preparations made during the planning stage.

Consequently, the interrogator must make a concerted effort to learn everything possible about the objective area—terrain, enemy, and weather—and relate these factors to the mission of the unit supported. Only by taking these steps will the interrogator be able to ensure success, and be prepared to begin interrogations as soon as possible after contact with the enemy is established. Interrogation objectives depend upon the mission assigned and type of unit supported.

FM 34-52

SPECIAL FORCES

Special Forces perform five primary missions:

- Unconventional warfare.
- Foreign internal defense.
- Direct action.
- Special reconnaissance.
- Counterterrorism.

The primary role of Special Forces is to influence deep, close, or rear operations beyond the forward limits of conventional military forces. These operations may extend into a hostile nation's homeland or into the territory of hostile states that threaten lines of communication in the friendly strategic rear.

AMPHIBIOUS OPERATIONS

The assault landing team is the basic subordinate task organization of the assault echelon of a landing force. Regardless of whether a battalion or brigade landing team is the basic element, it will operate independently during the first stages of the landing, and be organized to land, overrun beach defenses, and secure terrain objectives.

The interrogation element, along with CI teams, should participate in all aspects of the planning phase affecting the landing force to which it is attached. Interrogators should conduct specialized training. The chief interrogator should coordinate with the landing force intelligence officer on all matters concerning interrogators after the landing has been made.

The interrogators obtain as much background information about the enemy as possible to interrogate captured enemy personnel. Interrogators should study—

- All maps, charts, and photographs of the terrain and defenses of the landing areas.
- All INTREPs on the enemy armed forces in that area.
- Available information on enemy reserves, as well as on civilians residing in the area.

Interrogators should engage in other phases of training, including rehearsals, to smoothly execute embarkation, movement, and debarkation operations.

The interrogation element attached to an amphibious landing force will be OPCON to the landing force intel-

The Special Forces Group (SFG) normally deploys three two-person teams, as required, to support group operations. One of the teams may be attached to the joint interrogation facility (JIF). Special Forces interrogation activities include, but are not limited to—

- Interrogating EPWs, debriefing detainees and returned US personnel, and other persons of intelligence interest to the supported commander.
- Exploiting documents that appear to directly satisfy the supported commanders specific operational requirements (SORs).
- Participating in overt elicitation activities. These activities include liaison, escort, observer, and treaty verification measures.

ligence officer, and employed at his direction. Small interrogation teams may be formed, which will embark on separate ships. Communication silence will place an effective barrier between these teams until that silence is lifted.

When the assault begins, organizational artillery, air support, and naval gunfire depend primarily on shore units for accurate target information. As a result, interrogators may be required to concentrate their efforts on target acquisition.

The importance of information obtained from captured enemy personnel is magnified when establishing a beachhead. This is because the commander is unable to undertake probing actions to "feel out" the enemy as he can during a more conventional land operation.

INITIAL INTERROGATIONS

Interrogators should conduct initial interrogations near the landing beach close to the CP to communicate information without delay. If necessary, interrogators may be sent forward to operate with assault companies. EPW are turned over to the landing force shore party for custody and eventual evacuation.

Further instructions on interrogations and EPW handling are in the intelligence annex of the landing force operations order (OPORD). The interrogation of civilians for information of intelligence value also is an important part of the interrogation mission.

ESTABLISH AND OPERATE

When headquarters of the next higher echelon above the landing force has landed and established its CP, some of the interrogators may be returned to the command level from which they were originally detached. At this time, collecting points and interrogation facilities can be established and operated as in ordinary ground operations.

AIRBORNE OPERATIONS

The functions and basic methods of operations by interrogation personnel with airborne operations are similar to that of an infantry division. However, the method of employment of interrogators is somewhat different. Interrogators who are to operate with airborne units must understand the peculiarities in operations, as well as in training.

The most significant difference between airborne and normal ground operations is airborne operations are usually carried out behind enemy lines. Before the operation, airborne qualified interrogators must—

- Gain a realistic and complete picture of the enemy situation.
- Study enemy units identified in the objective area, and those capable of moving to counterattack our forces.
- Locate significant terrain features in the objective area.

The command echelon to which interrogators will be attached depends on each airborne battalion for the assault phase. Interrogators move into the objective area with the unit they are supporting. They are OPCON to the unit intelligence officer.

As soon as the objective areas and the missions of the respective units within an airborne force are designated, the interrogators who are to take part in the operation must receive details on most aspects of the operation. Interrogators must be provided with—

- The SIR and proposed H-hour.
- Maps, photographs, and other data required for interrogations.
- All information on enemy units which are outside the objective area, but are capable of being employed to counterattack US forces.

The shore party or helicopter support teams operate EPW collecting points in the vicinity of the landing beaches. EPW are evacuated from these points to designated ships by landing craft, helicopter, or amphibious vehicle. Retention in the objective areas is begun as increased facilities, supplies, and personnel permit, consistent with reasonable EPW safety from enemy action.

Interrogators should spend sufficient time coordinating with other intelligence specialists, particularly analysts, to provide a realistic and complete picture of the enemy situation.

They must study enemy units identified in the objective area, as well as significant terrain features, to provide a background for more comprehensive interrogations when the first EPWs are captured. Prior to the actual airborne assault, interrogators must know CP locations of the division and its subordinate units.

Interrogators involved in airborne operations must anticipate the numerous problems which will affect the interrogation mission. For example, it is conceivable during the assault phase that no basic transportation will be available to interrogation personnel; thus, flexibility is critical in planning and executing airborne operations.

COLLECTING POINTS AND INTERROGATION FACILITIES

Collecting points and interrogation facilities are established and operated as in other operations when—

- Headquarters of the next higher echelon above the assault units have been airdropped.
- Assault units have established physical contact with higher headquarters.

AIR ASSAULT (AIRMOBILE) OPERATIONS

Air assault operations are characterized by a high degree of tactical mobility. They are conducted by transporting infantry and field artillery units, with the necessary combat support (CS) and combat service support (CSS), into battle by helicopter. Once deployed on the ground, air assault infantry battalions fight like other infantry battalions. The essence of air assault tactics is a rapid tempo of operations over extended ranges. In division air assault operations, to support more than

FM 34-52

one brigade, there must be corps augmentation. FM 71-101 describes air assault operations.

Security of aircraft enroute to landing zones (LZs) is a major concern. Friendly aircraft and air defense support must ensure air routes are free of enemy aircraft and air defense systems.

When remotely monitored battlefield sensor systems (REMBASS) are available, friendly ground assets emplace REMBASS along likely enemy ground approach routes in the LZ to detect and report ground movement. Ground surveillance radar (GSR) is employed to warn of enemy movement on friendly flanks.

Air assault operations require extensive HUMINT support in operation planning. CI analysis is critical to ensure OPSEC measures are taken to prevent divulging critical information, such as—

- Date and time of operation.
- Size of force to be employed.
- Air routes to and from planned LZs.
- Planned LZ locations.

CI must also support staging area actions to prevent espionage, sabotage, and acts of terrorism which could adversely affect the operation.

Interrogation is a primary source of information for air assault operations IPB. Interrogation support of initial stages of the operation may be critical to its success.

The assault force commander needs immediate and current enemy intelligence. Lack of immediate questioning of EPWs captured in securing the LZs or in follow-up actions may cause failure of the operation.

Planners must consider the difficulty in getting EPWs back to a support area during the early stages of an air assault operation. Interrogators should support the air assault elements as soon as possible. This may mean an interrogation team is included in the air assault force to operate at a forward EPW collecting point established in the vicinity of the LZ.

Normally, one interrogation team should support each air assault battalion during the assault phase. If the air assault battalion is using more than one LZ, the team may be split to support each LZ.

After assault units have established a ground link-up, some or all of the interrogators may be returned to the echelon of command from which they were detached.

Interrogators supporting the early stages of an air assault operation must be provided with the SIR, which are critical to the operation's success. Interrogators must plan ahead on how to question EPWs to satisfy immediate collection requirements.

ARMORED AND MECHANIZED INFANTRY OPERATIONS

Armored units normally operate on extensive fronts, with deep zones of action and dispersed formations. Because of the mobility and wide range of action of armored units, interrogation normally is not as detailed as in other divisions. Interrogators must remain mobile, operate with minimum facilities, and be alert for sudden changes in the tactical situation.

Planning and Operation

With a few exceptions, the planning and preparation necessary for interrogators supporting armored units is the same as for those supporting regular infantry units. Since radio is the normal means of communication, all interrogation team members must be familiar with voice radio procedures and know how to operate radio equipment common to armored units.

Interrogator Employment

Interrogator personnel who support armored or mechanized units will come under OPCON of the J2, G2, or S2 of the supported unit. Interrogators at all levels of armored or mechanized units must be able to operate during fluid situations, and remain mobile at all times. Because of this mobility, liaison with the J2, G2, or S2 will not be as frequent as in other units.

Interrogators must operate with maximum efficiency on the basis of radio communications, messages, and written reports. As in other type units, interrogation personnel remain OPCON to the G2 until operations begin. At that time, the division MI battalion will attach interrogation personnel to subordinate units. After an operation is completed, interrogation personnel will revert to division control, pending a future mission.

Normally, interrogations within armored units will be limited to interrogating EPWs for location and deployment of antitank weapons and defenses, enemy roadblocks, and presence of enemy armor. In fast

moving offensive operations, interrogators are best employed with the forward elements of the units.

Limited Interrogations

EPWs are questioned briefly at the point of capture (POC), and evacuated to division EPW forward collecting points, or are turned over to division MP for evacuation. Interrogators with battalions and brigades in armored operations should have vehicles equipped with radios so they can communicate with the respective intelligence officers and other intelligence agencies.

General exploitation techniques and procedures are modified to fit the environment and objectives of each interrogation.

EPWs are a primary source of information during tactical operations. The ability to exploit that source is a critical factor in mission success. EPWs are first-hand and last-minute observers of enemy operations. They represent one of the few forms of direct association with the enemy and usually possess valuable information.

Other sources of information are enemy and friendly civilians, refugees, defectors, captured agents, and informers. Because these sources may have lived in or passed through areas occupied or controlled by the enemy, they can provide valuable information.

CEDs are another important source of information which interrogation personnel will exploit in tactical operations. Documents will be found in the possession of EPWs or other detainees and on the battlefield. Often, they provide critical and sometimes detailed enemy information.

CAPTURE RATES

US military involvement in tactical operations during and since World War II has shown that conflict generates large numbers of EPWs, other detainees, and CEDs. The higher the intensity of conflict, the larger the number of EPWs, detainees, and CEDs.

In OPERATION DESERT STORM, EPWs were captured, and surrendered, in such great numbers that many with information had little or no contact with interrogators until they were transported to rear area collecting points. By this time, any tactical information they had was of limited use.

In LIC operations in Grenada and Panama, the EPW capture rate was lower, but the detainee rate was higher. The following factors contributed to an extreme challenge for interrogation operations:

- Limited size of US forces.
- Limited number of language-qualified interrogators.
- The focus on local populace.
- Massive amounts of CEDs.

To be successful, interrogation support to tactical operations must be carefully planned. Available interrogation assets must be balanced against the operations objective, enemy situation estimate, and projected EPW capture rates.

The formulas in Table 2-1 are used to estimate the approximate division-level EPW capture rates. These formulas could vary according to type of conflict and mission.

Table 2-1. Division-level EPW capture rate.

<u>Defensive Posture</u>	<u>Offensive Posture</u>
.00035 EPWs* = 9 EPWs/day	.00367 EPWs* = 94 EPWs/day
*per combat soldier per day.	

Counterinsurgency Operations

EPW capture rate for counterinsurgency operations may be very low. However, failure of the enemy to wear a uniform or other recognizable insignia results in an identification problem. As a result, large numbers of

civilian suspects may also be detained during operations.

This requires individual screening at brigade and division levels of detained personnel to determine their status and appropriate disposition. In Viet Nam, the ratio of EPWs approximated one for each six detainees taken into custody.

FM 34-52

Terrorists

Terrorists are a fact of contemporary life. They are dedicated, intelligent, well financed, resourceful, and astute planners. They are difficult to identify and are not easily captured or interned. The use of terrorist tactics worldwide has increased significantly over the past 25 years, and this trend is not expected to abate in the future.

Besides peacetime, acts of terrorism should also be expected in time of armed conflict. US forces must be prepared to engage in counterterrorist activities to assist the civil and military police. Current doctrine states counterterrorist activities may involve use of general purpose forces as well as those specifically organized and trained in counterterrorist techniques. There is no data available on projected terrorist capture rates.

INTERROGATOR SUPPORTED OPERATIONS

Combat operations which the tactical interrogator supports are discussed below. No matter what the operation is called, it is still incumbent upon the interrogator to gain critical combat information in support of that operation. The interrogator plays a key role to ensure the combat operation is a success.

OFFENSIVE OPERATIONS

Successful offensive operations demand imagination, thorough coordination, and skilled execution. These operations are characterized by—

- Aggressiveness.
- Initiative.
- Rapid shifts in the main effort to take advantage of opportunities.
- Momentum.
- Deep and rapid destruction of enemy forces.

Offenses should move fast, follow successful probes through gaps in the enemy defenses, and shift strength quickly to widen penetrations and reinforce successes to carry the battle deep into the enemy rear operations. They should destroy or control the forces or areas critical to the enemy's overall defensive organization before the enemy can react.

In the offense, certain principles are essential to battlefield success:

- Knowing the battlefield.

INTERROGATION OF PROTECTED PERSONS

Civilians and refugees caught in the middle of a conflict are protected by the GWS, GPW, and GC. Most of the provisions discussed below apply whether the civilian or refugee is found in the territory of a party to the conflict, or in occupied territory. Civilians and refugees fall into the broadly defined category of protected persons under the GC.

It is important to keep in mind that protected persons, even those who might be detained by you, are not EPWs. They must be treated differently and kept segregated from EPWs. The rights and protections afforded EPWs and protected persons, as well as those control and disciplinary measures that may be used against them, are different. Appendix D provides GWS, GPW, and GC provisions for protecting persons rights.

- Denying the enemy intelligence.
- Disrupting and destroying enemy command, control, communications, and intelligence (C³I).
- Maintaining operational integrity.

Interrogation provides a high percentage of information on the enemy and terrain which, along with weather, are the key elements in knowing the battlefield.

Movement to Contact

Movement to contact is a tactical operation to find and engage the enemy. The force is organized to hold the bulk of its combat power in the main body. It moves aggressively toward the enemy, making maximum use of IEW resources to find the enemy before the enemy detects the friendly force.

When contact is made, combat information and intelligence determine where and with what force to attack and overcome enemy resistance. Interrogation is an important source of that information.

In a movement to contact, the friendly force may encounter an enemy defending or moving to contact. Once contact is made, the action must be resolved quickly if the movement to contact operation is to continue. This is normally done by a hasty attack launched as quickly as possible with whatever assets are on hand. No time is available for detailed IPB and analysis, other than what has been done prior to movement to contact. The analyst quickly updates the intelligence analysis for

as quickly as possible with whatever assets are on hand. No time is available for detailed IPB and analysis, other than what has been done prior to movement to contact. The analyst quickly updates the intelligence analysis for the commander and continues the update as the attack progresses.

IEW resources look deep to determine second-echelon vulnerabilities. These vulnerabilities form the basis for friendly offensive action, particularly deep interdiction.

While continuing to look deep, IEW resources also support close operations directly. They continue to be sensitive to enemy vulnerabilities which would bring maximum friendly success when exploited. Where possible, IEW resources support deception operations.

In the movement to contact, interrogators should be deployed forward to interrogate EPWs as well as indigenous personnel, particularly refugees, to determine as much as possible about the enemy and terrain which lies in the path of the advancing force.

Meeting Engagement

The meeting engagement may be the result of movement to contact. It occurs when a moving force, incompletely deployed for battle, engages an enemy force about which it has inadequate intelligence. Once contact is made, electronic countermeasures (ECM) are employed against enemy key C³ and electronic guidance systems.

All available collection resources deploy to determine the size, composition, disposition, capabilities, and intentions of the enemy force. They immediately report critical information, such as the location of assailable flanks and other enemy vulnerabilities, to the force commander. The commander needs this information quickly to decide whether to bypass, attack, or defend against the enemy.

Meeting engagement battles can be avoided if IEW resources are effectively integrated and used. If intelligence is effective, the commander can prepare for battle before encountering the enemy force.

Hasty and Deliberate Attacks

In hasty and deliberate attacks, IEW tasks are virtually the same. MI resources determine as much information as possible about the enemy's defensive posture. Key information determined by IEW assets includes—

- How the enemy's defense is organized.

- Where enemy reserve and counterattack forces are located, and when they move.
- What NBC weapons systems the enemy has, and where they are located.
- Where the enemy's conventional artillery is located.
- Where enemy radio electronic combat (REC) assets are located.

In a hasty attack, the need for rapid collection of combat information is critical. In such an attack it may be advantageous to deploy interrogation teams down to battalion level to operate in a similar manner as in the movement to contact.

In the deliberate attack, intelligence on the enemy is more complete, and interrogation support may not be provided below brigade. However, planning for a deliberate attack should task organize interrogation assets to satisfy the greatest need.

For example, a committed brigade that conducts the main attack receives the support of two interrogation teams; a brigade in a supporting attack receives only one team; and a brigade in reserve receives no interrogation support.

Exploitation and Pursuit

Commanders planning offensive operations must be prepared to conduct exploitation and pursuit actions. Without prior detailed planning for these contingencies, fleeting opportunities to press a successful attack to completion may be missed. IEW resources, particularly MI assets, play an important part in planning for and executing exploitation and pursuit missions.

IPB is critical and helps identify enemy vulnerabilities. Intelligence supports targeting by identifying, locating, and tracking enemy forces which may move to counter exploitation forces.

After the initial assault, MI assets determine the integrity of enemy defenses. They locate gaps, holes, and weak spots that may be exploited. They determine if the enemy intends to defend in place, delay, or withdraw to subsequent defensive positions. ECM are maximized to increase enemy force confusion.

Reconnaissance In Force

A reconnaissance in force (RIF) is a limited objective operation by a substantial force to obtain information and to determine enemy dispositions and strengths.

FM 34-52

The RIF also tests enemy reactions to friendly force action. Enemy reactions may reveal major defensive weaknesses which could be exploited.

Even when using RIF to gain information, commanders executing it must be alert to seize an opportunity to exploit tactical success. If the enemy situation must be developed across a broad front, a RIF may probe the enemy at selected points.

Recognizing that RIF is primarily an information-gathering operation, commanders must carefully consider the risks involved. Precise plans must be made in advance to extricate the force or to exploit success.

In many respects, MI RIF support is like movement to contact. Interrogation support is critical since EPWs will be an important source of the information the RIF seeks. Interrogation support, described in movement to contact, may be the most efficient means of supporting the RIF.

River Crossing

River-crossing operations are an integral part of land warfare. The objective of any river-crossing operation is to project combat power across a water obstacle while ensuring the integrity and momentum of the force. Because the modern battlefield is so lethal, and small enemy units can be destructive, crossings must be quick and undetected. Therefore, it is essential that rivers be crossed in stride as a continuation of operations.

MI units contribute to the planning and execution phases of river-crossing operations:

- IPB enables the commander to select the best crossing site and know the battlefield beyond, so operations can be sustained without interruption.
- IEW forces deploy forward and continue seeking enemy weaknesses for exploitation, and to warn of enemy forces capable of affecting the operation.
- Other elements guard the flanks to prevent enemy surprise.
- MI resources further help the commander know the battlefield and guard against a surprise attack by identifying, locating, and tracking enemy NBC-capable delivery systems.

Based on the picture of the battlefield drawn by the G2 as a result of IPB, the commander decides whether the crossing will be—

- Hasty or deliberate.

- Day or night.
- Wide or narrow on the front.

MI units normally are not part of the assault force; however, GSR teams may accompany the assault force if surveillance of enemy approaches to the exit bank cannot be conducted from the entry bank. Additionally, interrogators should be included in the assault force if immediate EPW exploitation is deemed critical to developing intelligence on the exit-bank battlefield.

Evacuation of EPWs back over the crossing site to a support area collecting point normally will be delayed. This is due to the need to get the maximum amount of force across the river in the shortest time. Two-way traffic in the early stages of the crossing may be precluded.

A forward collecting point on the exit-bank side of the river may be established immediately behind the assault force, and interrogations can be conducted to obtain information critical to the immediate situation. To accomplish this, organization of interrogation assets as outlined under movement to contact may be employed.

DEFENSIVE OPERATIONS

Defensive operations can retain ground, deny the enemy access to an area, and damage or destroy attacking forces. They cannot, however, win the battle by imposing the will of the commander on the enemy. For this reason, the defense is a temporary expedient, undertaken only when it is impossible to conduct offensive operations, or when attacking in another area. All defensive actions are undertaken in anticipation of ultimately resuming the offense.

Commanders plan the overall defensive effort on the basis of the METT-T. MI assets are allocated within the elements of the organizational framework to support the overall scheme. The IEW principles for supporting offensive operations apply to the defense, as well as to other operations. Interrogation support to defensive operations, likewise, is basically the same as that provided to offensive operations. Listed below are important factors to consider in defensive operations:

- The primary focus of intelligence requirements is on which enemy will attack and when, where, and how they intend to do it.
- The decentralized, fluid nature of the covering force battle requires interrogation support at the lowest possible echelon. This requires DS inter-

rogation teams from the division MI battalion and the MI brigade (Corps). Questioning of civilians and EPWs is brief and is conducted to obtain information of immediate tactical value. Interrogators gather information about the identification, composition, disposition and direction of movement, strength, and capabilities of enemy forces involved in the immediate covering force battle.

- More interrogation support is required at corps. The enemy has the initiative, and will probably conduct operations in the friendly rear area.

Support of defense operations requires the closest management of interrogation assets. The necessity to

support the covering force must be balanced against the increased corps rear operations support. The increased emphasis on rear operations may mean fewer corps interrogation assets available to support division.

The G2, in coordination with the MI unit commander, may determine that an echelon between the covering force and corps will not be supported. For example, EPWs may be interrogated by DS interrogators supporting the covering force, and then be evacuated back to division, bypassing brigade. Additionally, the five-member DS team, which provides flexibility, may have to be reduced to two or three interrogators. Table 2-2 shows interrogation support in LIC.

Table 2-2. Interrogation support in LIC.

<p>INSURGENCY</p> <ul style="list-style-type: none"> • Interrogate EPWs and detainees. • Exploit CEDs. • Provide PSYOP linguistic support. • Train insurgent combatants in interrogation techniques. <p>COMBATTING TERRORISM</p> <ul style="list-style-type: none"> • Provide PSYOP linguistic support directed against terrorists. • Provide CA linguistic support. • Provide linguistic support for liaison with military or paramilitary HQ. • Provide linguistic support during PW exchanges. • Debrief members of US peacekeeping forces for intelligence purposes. 	<p>COUNTERINSURGENCY</p> <ul style="list-style-type: none"> • Interrogate EPWs and detainees. • Exploit CEDs. • Train HN forces in interrogation techniques. • Provide linguistic support to other US forces, advisors, and trainers. • Provide PSYOP linguistic support. • Provide CA linguistic support. • In counter-drug operations— <ul style="list-style-type: none"> —Train HN personnel in interrogation techniques. —Exploit and analyze drug-related documents. <p>PEACETIME AND PEACEKEEPING OPERATIONS</p> <ul style="list-style-type: none"> • Provide PSYOP linguistic support. • Debrief knowledgeable civilians being evacuated from danger zones during NEO. • Support counter-drug operations by— <ul style="list-style-type: none"> —Training HN personnel in interrogation techniques. —Exploiting and analyzing narcotics-related documents.
---	---

FM 34-52

THEATER INTERROGATION FACILITY

The EAC interrogation facility will normally be designated as the TIF. A TIF is staffed by US Army interrogators and analysts, with support from Air Force, Navy, Marine Corps, and other US national agencies as required. In a multinational operation, a combined interrogation facility may be established with allied interrogator augmentation. In addition to conventional theater Army operations, a TIF may be established to support a joint or unified command to meet theater requirements during crisis or contingency deployments.

MI battalion companies, MI brigade (EAC) provide US Army interrogation support to the EAC TIF. The mission of the TIF is to—

- Establish liaison with host nation (HN) commanders to achieve critical intelligence information in response to theater and national level intelligence collection requirements.
- Ensure communication between HN and US military TIF commanders, and establish rapport with HN interrogation activities.
- Coordinate for national level collection requirements.
- Interrogate PWs, high-level political and military personnel, civilian internees, defectors, refugees, and displaced persons.
- Participate in debriefings of US and allied personnel who have escaped after being captured, or who have evaded capture.
- Translate and exploit selected CEDs.
- Assist in technical support activity (TSA) operations (see FM 34-5(S)).

The MI battalion (I&E) has an HHC for C³, and three interrogation companies, of which one is Active Component (AC) and the other two are RC. The companies consist of two MI companies, I&E (EPW support) and one MI company, I&E (GS-EAC).

The two MI companies support EPW compound operations. Their elements are primarily for GS at EAC, but may be deployed for DS at corps and division. The MI company (I&E) (GS-EAC) provides priority interrogation and DOCEX support to corps and divisions, to the TIF, and to temporary EPW compounds as required.

A TIF is organized into a headquarters section, operations section, and two interrogation and DOCEX sections. It will normally have an attached TSA section from Operations Group, and a liaison team from the Joint Captured Materiel Exploitation Center (JCMEC). The JCMEC liaison team assists in exploiting sources who have knowledge of captured enemy weapons and equipment.

The headquarters section provides all command, administrative, logistical, and maintenance support to the TIF. It coordinates with—

- Commander, MI Battalion (I&E) for personnel status, administrative support, and logistical support prior to deployment.
- Battalion S3 for deployment of interrogation assets.
- Theater J2 for reporting procedures, operational situation update, and theater and national level intelligence requirements.
- Provost marshal for location of theater EPW camps, and for procedures to be followed by interrogators and MP for processing, interrogating, and internment.
- Commanders of theater medical support units and internment facility for procedures to treat, and clear for questioning, wounded EPWs.
- Commander, CI company, for CI requirements and joint interrogation and CI procedures.

OPERATIONS SECTION

This section (where ideally the officer in charge [OIC] has the 3Q additional skill identifier) is organized into the operations, OB, and communications elements. The operations section—

- Designates work areas for all TIF elements.
- Establishes and maintains TIF functional files.
- Establishes interrogation priorities.
- Maintains a daily log and journal.
- Disseminates incoming and outgoing distribution.
- Conducts liaison with local officials, adjacent and subordinate intelligence activities, CI, MP, PSYOP, the JCMEC, Plans and Policy Directorate (J5), and provost marshal.

- Conducts coordination with holding area OIC or enclosure commander for screening site, medical support, access, movement, and evacuation procedures for EPWs.
- Conducts operations briefings when required.
- Manages screening operations.
- Manages EPW access for intelligence collection.
- Assigns control numbers (see DIAM 58-13).
- Supervises all intelligence collection activities within the TIF.

OB ELEMENT

This element—

- Obtains the initial data base and updates and maintains it.
- Establishes and maintains OB workbooks and files to include data generated by intelligence information which has not been verified.
- Maintains SITMAPs displaying enemy and friendly situation.
- Catalogs, cross-references, and disseminates collection requirements to TIF collection elements.
- Reviews INTREPs for inclusion into data base.
- Conducts OB briefings when required.

OTHER MI ELEMENTS

Collection missions are tailored and assigned by the CM&D section subordinate to the G2 at corps and division. The same functions are performed at brigade and battalion by the battlefield information control center (BICC). These elements must ensure the assigned collection mission is passed by secure means, through established channels, to the interrogation element.

If interrogators are deployed in a GS role, the CM&D section will pass its interrogator taskings to the MI battalion TOC. If interrogators are deployed in a DS role, they will receive taskings directly from the BICC.

The CM&D section (through the MI battalion TOC) or the BICC must maintain close contact with the interrogation element. This contact allows a two-way flow of communication.

The CM&D or BICC element needs the contact to accomplish the preceding three steps. They also use the contact to revise the interrogation element's collection

mission as required. The interrogation element requires the contact to ensure it receives current guidance, direction, and assistance in solving collection problems.

ALL SOURCE ANALYSIS SYSTEM (ASAS)

This system provides assistance to the J2, G2, or G3 and MI unit commanders who collect and analyze intelligence and perform CI and EW functions. The following elements feed into the ASAS.

Imagery Exploitation

Interrogators should maintain close contact with imagery exploitation elements. Interrogators may be required to identify items on air photographs and should report information of interest to the imagery analysts. Imagery analysts can aid interrogation personnel by furnishing photographs for use in connection with interrogation and by verifying leads originally obtained through interrogation.

TECHINT Personnel

Normally, interrogation elements coordinate with the TECHINT sections of the RC battalion (TE). The TECHINT section, and its field teams, furnishes guidance and requirements to the interrogation elements through questionnaires and interrogation guides. These are valuable aids to the interrogator in obtaining specific TECHINT information.

Interrogators notify the nearest TECHINT personnel to obtain detailed technical information and guidance. At tactical levels, this is the exception rather than the rule, but it may be necessary when information is of immediate tactical value.

COUNTERINTELLIGENCE

Coordination between CI and interrogation elements is always necessary. This coordination is effected continuously, directly or indirectly, and at the discretion of the intelligence officer. CI elements are active in the security screening of refugees and civilians in the combat zone.

CI personnel and interrogators must work together to ensure proper interrogation of enemy civilians or personnel speaking the enemy's language. Interrogator personnel can further assist the CI effort by—

- Furnishing leads on suspected enemy agents and intelligence personnel.
- Informing CI elements concerning enemy personnel dressed in other than enemy uniforms.

FM 34-52

- Referring to CI elements, or making available to them for interrogation, all EPWs and other sources of CI interest. CI personnel are trained for interrogation in cases of suspected espionage, sabotage, or subversion. Their knowledge of the CI situation (to include hostile intelligence activities) enhances full exploitation of appropriate sources.

MILITARY POLICE

The corps MP commander operates the corps EPW holding area and provides escort guard support to divisions for EPW evacuation in routine or medical channels. EPWs are evacuated from the corps holding area to the next higher echelon with the least possible delay.

The MP commander also arranges and coordinates transportation requirements to include rations and water, if required, for the movement to include number of vehicles, railroad or passenger cars, or aircraft within the time and place of departure.

Expedient EPW evacuation is provided by the prior dispatch of escort guards to establish a ready reserve at the supported divisions. This reserve evacuation capability is maintained by sending additional escort

SUPPORT RELATIONSHIPS

Successful interrogation operations require support from elements within their echelon of assignment, including all major staff organizations. These elements are collectively responsible for the planning that creates the overall environment for interrogators. The intelligence staffs (J2, G2, or S2) direct contribution to interrogation operations has already been discussed. Its general responsibilities are outlined below, along with those of other staff and support elements.

PERSONNEL (G1 AND S1)

The G1 and S1 are responsible for—

- Supervising the medical support furnished to sources.
- Maintaining a list (by language and proficiency) of qualified linguists within their command.
- Coordinating with the G5 for procurement and payment of other interpreters and translators needed to perform intelligence and nonintelligence duties.

The G1 and S1 ensure the echelon's operations plan (OPLAN) contains complete provisions for source han-

guards on a continuing or as required basis. These guards may also be attached to EPW and processing reception camps as needed.

EPW administrative processing is done by MP PW processing units. Processing includes personnel record preparation, fingerprint and identity cards (if needed), and internment serial number assignment.

PSYOP

Normally, interrogation elements coordinate with PSYOP elements to obtain information concerning the motivational factors and cultural value systems of the individuals to be interrogated.

PSYOP units, as a part of their normal operations, develop detailed analysis concerning psychological and cultural factors of friendly and hostile elements in the AO. Such information will help interrogation personnel to understand the source's attitude, value system, and perception; it will also help to obtain information more rapidly, and at the same time, PSYOP information on current conditions in enemy country or among enemy forces. A PSYOP PIR would be established to cover this requirement.

ding and evacuation. This plan must satisfy the interests of all other staff officers and provide for—

- Humane treatment of all sources.
- Prompt evacuation from the combat zone.
- Opportunities to interrogate sources.
- Integration of procedures for the evacuation, control, and administration of sources with other CS and CSS operations (through the provost marshal).
- Training for all troops on the provisions of international agreements and regulations relating to sources.
- Ensuring delivery of EPW and detainee mail.
- Maintaining EPW and detainee statistics.
- Administration and control of EPW currency and pay records, to include coordination with appropriate intelligence authorities about investigation of large sums of money.

INTELLIGENCE (J2, G2, AND S2)

The J2, G2, and S2 are responsible for supervising appropriate censorship activities relating to sources. They also—

- Coordinate with the G3 to ensure plans for interrogation, CI, PSYOP, and CA operations are included in unit training plans and OPLANs.
- Draft instructions for MI handling, evacuating, and exploiting captured enemy personnel and CEDs. (They coordinate with the G3 to ensure draft instructions are included in the command SOP, OPLANs, and supplementary orders.)
- Project source capture flows.
- Determine the number of interpreters and translators needed to perform intelligence duties.
- Control the procedures used to process and grant clearances to the interpreters and translators who need them.
- Coordinate with G5 on screening of non-suspect local nationals and displaced persons.

OPERATIONS (G3 AND S3)

The G3 and S3 are responsible for operations, plans, organization, and training. Where MP assets are not available, or insufficient, they are responsible for obtaining, organizing, and supervising employment of additional personnel as guards. The G3 and S3—

- Prepare, coordinate, and publish the command SOP, OPLANs, and supplementary orders. This includes instructions for handling, evacuating, and exploiting captured enemy personnel and CEDs, which are drafted by the G2.
- Incorporate interrogation operations into future plans and operations.
- Ensure subordinate units are trained in proper handling and evacuation of captured enemy personnel, captured enemy materiel (CEM), and CEDs.
- Train guard personnel.
- Provide G2 and S2 with details of planned operations.
- Plan and supervise all PSYOP activities in support of tactical operations.

- Evaluate, in coordination with the G2 and G5, enemy PYSOP efforts and effectiveness of friendly PSYOP on target groups.

SUPPLY (G4 AND S4)

The G4 and S4 are responsible for storing and maintaining supplies and equipment needed by subordinate units to conduct source handling operations, as well as delivering them to subordinate units as they are needed. The G4 and S4 also supervise—

- Command policy for evacuation and internment of captured enemy personnel, and evacuation and safekeeping of CEM and CEDs.
- Real estate acquisition and construction of source holding area facilities.
- Collection and distribution of captured enemy supplies. (This is coordinated with the intelligence and operations staffs.)
- Procurement and distribution of rations to source holding areas. (Captured enemy rations will be used when possible.)
- EPW and detainee transportation.
- Determination of requirements for use of source labor for the logistical support needed in source handling operations.
- Logistical support to interpreter personnel.

CIVIL-MILITARY OPERATIONS (G5 AND S5)

The G5 and S5 are responsible for CA. They—

- Advise, assist, and make recommendations that relate to civil-military operations (CMO) and CA aspects of current or proposed operations.
- Prepare estimates and conduct studies and analyses for CMO activities.
- Prepare the portions of operations, administrative, and logistics plans and orders for CMO activities.
- Determine requirements for resources to accomplish command CMO activities, including CA units and personnel.
- Coordinate with local US government, G1 and S1 representatives, and HN armed forces for procuring native linguists for interpreter support.
- Recommend command policy on obligations between civil and military authorities; on the AO

FM 34-52

population; and on the works and activities arising from treaties, agreements, international law, and US policy.

- Provide civil support for tactical and CSS operations and prevent civilian interference with these operations.
- Coordinate military support of populace and resource control programs.
- Provide technical advice and assistance in reorientation of sources and enemy defectors.
- Coordinate MI aspects of CMO activities with the G2 or S2.

ADDITIONAL SUPPORT

Besides the major staff elements, an interrogation element requires support from several other elements in order to conduct operations. These elements are discussed below.

Communications

Secure, reliable communication must be available at or near the interrogation element's deployment site. Priority access to these communications must be arranged to support contact with collection management.

Staff Judge Advocate

This element can provide legal support and advice on the interpretation and application of international regulations and agreements about handling sources. It is also a channel for reporting known or suspected war crimes.

Health Service Support

This element must clear all sick and wounded sources before they can be interrogated. Seriously sick or wounded sources are evacuated through medical channels. If adequate facilities are not available in EPW hospitals, EPWs are admitted to military or civilian medical facilities where treatment can be obtained.

Each EPW is medically examined and weighed at least once a month. Provisions are made for the isolation of communicable cases, disinfection, and inoculations. Retained medical personnel and EPWs with medical training are used to care for their own sick and wounded.

NBC Protection

All EPWs will be provided NBC protection. If EPWs do not have their own NBC protection equipment, or their equipment is not usable, the detaining forces must provide them with proper NBC gear.

Chaplain Support

The unit ministry team, consisting of the chaplain and chaplain assistant, provides religious support. The team coordinates with the G5 and S5 to provide religious support for refugees, displaced persons, and indigenous civilians. It provides services for EPWs or assists detained clergy of enemy forces and other detained clergy. The team provides burial rites according to the religious rites of combatants. Religious preference of EPWs will be obtained from DA Form 4237-R (Detainee Personnel Record) (see Chapter 3).

Inspector General

This element is a channel for reporting known or suspected war crimes.

Public Affairs officer

The public affairs officer advises and informs the commander of public affairs impact inherent in planned or implemented EPW operations.

Engineer Officer

The engineer officer assists in planning the construction of EPW enclosures. He also assists the G2 and S2 in developing obstacle intelligence (OBSTINTEL) during the IPB. OBSTINTEL requirements are reflected in the PIR and IR. Much of the IR is technical in nature and warrants direct coordination with the interrogator to ensure the right questions are asked. Through the J2, G2, and S2, he will also analyze the information collected and its impact on the maneuver and engineer plan.

Military Band Unit

At division and corps, the band may augment the MP by providing security at central collecting points and corps holding areas.

CHAPTER 3 THE INTERROGATION PROCESS

Criteria for selecting personnel to be interrogated vary with the—

- Commander's collection requirements.
- Time limitations.
- Number and types of potential sources available.
- Exact circumstances surrounding the employment of US Forces.

In this regard, source selection is important in conducting interrogation at tactical echelons of command because of the proximity to enemy ele-

ments, number and conditions of detainees, and time restrictions.

The interrogation process involves screening of sources for interrogation and the use of interrogation techniques and procedures. Screening and interrogation involve complex interpersonal skills, and many aspects of their performance are subjective. Each screening and interrogation is unique because of the interaction between the interrogator and the source.

The five interrogation phases—planning and preparation, approach, questioning, termination, and reporting—are discussed later in this chapter.

COLLECTION PRIORITY

Interrogators are trained to exploit sources and CEDs. This allows the all-source collection manager three exploitation options for interrogation assets: They may exploit sources alone, exploit CEDs, or exploit both simultaneously.

In the past, it was assumed interrogators could accomplish the dual collection mission no matter what type of combat operations were being supported. This may no longer be true. Unit staffing, coupled with the amount of CEDs and sources, may prevent exploitation of sources and CEDs simultaneously.

The density of interrogation assets and command emphasis on the collection effort determine mission requirements. The feasibility of a dual collection mission may also be the result of initial IPB by the commander's intelligence staff. If an echelon cannot conduct a dual collection effort, interrogating sources receives the priority for two reasons:

- The greater intelligence potential of a source.
- The rate at which people forget detailed information.

An individual's value system is easier to bypass immediately after undergoing a significant traumatic experience. The circumstances of capture are traumatic for most sources. Many former PWs indicated extreme disorientation immediately after capture. Capture thrusts them into a foreign environment over which they have no control. Their mores were of no use to them during this period. Most of them survived this phase by

clinging to very basic values (love of family and loyalty to friends or comrades).

Since humans are adaptable, this initial vulnerability passes quickly. An individual's established values begin to assert themselves again within a day or two. When this happens, much of an individual's susceptibility to interrogation is gone.

Memory stores information in two areas: short-term and long-term memory. The five senses constantly transmit information to the brain's short-term memory temporarily and then shifts to the brain's long-term memory. The time at which this transfer takes place varies, but research shows a great amount of detail is lost during that transfer. The percentage of information lost beyond recall varies from study to study, but 70 percent is a conservative estimate.

Much of the information of value to the interrogator is information the source is not aware he has. Although no research data is available in this area, it is likely this type of information will be lost quickly.

CEDs, while not affected by memory loss, are often time-sensitive and thus are screened quickly for possible exploitation (see Chapter 4).

The supported echelon's intelligence officer determines the guidelines for priority of exploitation. The commander's intelligence needs and the J2's, G2's, or S2's estimate of the enemy's intentions dictate the extent to which these guidelines can be applied. Exploitation priorities are reviewed and changed when needed.

FM 34-52

SCREENING

Screening is the selection of sources for interrogation. It must be conducted at every echelon to—

- Determine source cooperativeness and knowledgeability.
- Determine which sources can best satisfy the commander's PIR and IR in a timely manner.

PREPARE TO CONDUCT SCREENINGS

Screeners should obtain a copy of the element's overall objective statement from the PIR, IR, and SIR and become familiar with the intelligence indicators listed there. Screeners must use their experience and imagination to devise ways to identify EPWs and detainees who might possess information pertinent to these indicators.

For example, one group of indicators may concern new enemy units moving along a specific avenue of approach. In this case, a screener may want to concentrate first on screening EPWs and detainees captured near that location. When he questions those EPWs or detainees, the screener might try to determine what units are due to arrive in that area in the near future. The ability to recognize branch of service and rank insignia can be of great assistance to screeners.

Screeners coordinate with MP holding area guards on their role in the screening process. The guards are told where the screening will take place, how EPWs and detainees are to be brought there from the holding area, and what types of behavior on their part will facilitate the screenings.

DOCUMENT SCREENING

If time permits, screeners should go to the holding area and examine all available documents pertaining to the EPWs and detainees. They should look for signs that certain EPWs and detainees are willing, or can be induced, to cooperate with the interrogator. Previous screening and interrogation reports and EPW personnel records are important.

Interrogation reports identify EPWs and detainees who have been cooperative in the past. Prior screening reports indicate EPWs and detainees who appear cooperative. During EPW inprocessing, MPs prepare a DA Form 4237-R, which is prescribed by AR 190-8. A sample is shown at Figure 3-1. DA Form 4237-R contains additional information not required by the GWS, GPW, and GC, but which the EPWs and detainees may have volunteered during inprocessing. The volunteer-

ing of information is one indicator of EPWs or detainee's cooperation.

When examining documents, screeners should identify topics on which EPWs and detainees have pertinent information. Screeners should make a note of any documents captured with specific EPWs and detainees that may contain indications of pertinent knowledge and potential cooperation.

PERSONNEL SCREENING

If time permits, screeners should question holding area personnel about the EPWs and detainees. Since these personnel are in almost constant contact with the EPWs and detainees, their descriptions of specific ones can help identify sources who might answer the supported commander's PIR and IR.

Screeners should identify and note those EPWs and detainees whose appearance and behavior indicate they are willing to cooperate immediately or are unlikely to cooperate ever. Unless time is critically short, screeners should—

- Personally observe the EPWs and detainees.
- Pay attention to rank and branch of service insignias, and condition of uniform and equipment.
- Carefully observe the behavior demonstrated by other EPWs and detainees.
- Look for things like attempts to talk to the guards, intentional placement in the wrong segregation group, or any overt signs of nervousness, anxiety, or fright.
- Note any EPW or detainee whose appearance or behavior indicates willingness to talk.

CI SCREENING

Before initiating the screening process, the interrogator establishes liaison with supporting CI agents. The CI element, through the CM&D, provides PIR of CI interest. During the screening process, interrogators identify sources of CI interest. After these sources have been interrogated for any information of immediate tactical value (as needed), they are turned over to CI. CI is interested in sources who—

- Have no identification documents.
- Have excessive or modified identification documents.

DETAINEE PERSONNEL RECORD			
For use of this form, see AR 100-8, the proponent agency is OD-CSEPR.			
PART I - TO BE COMPLETED AT TIME OF PROCESSING			
1. INTERMENT SERIAL NO. (1-12)	2. NAME (Last, first, middle) (14-34)	3. RANK (20-37)	
CARD I US-1501-23176	CH'OE, HYON-SIK	SRSGT	
4. ENEMY SVC NO. (28-46)	5. TYPE (47)	6. DATE OF CAPTURE (48-53)	7. DATE OF BIRTH (54-59)
5611642	REG	8 OCT 99	24 FEB 77
8. NATIONALITY (60-61)	9. EDUCATION (62)	10. RELIGION (63-64)	11. MARITAL (65)
KOREAN (DPRK)	10 year compulsory	None	Single
12. PW CAMP UIC (66-71)	13. PW PROCESS DATE (72-77)	14. SEX (74)	15. LANGUAGE I (75-76)
US-AA3CU	8 Oct 99	M	KOREAN
16. LANGUAGE II (77-78)	17. PHYSICAL CONDITION (79)	18. PW CAMP LOCATION (20-22)	19. ENEMY UNIT (23-34)
KOREAN	Good	AB654321	3BN, 34REGT, 17INF DIV.
20. ARM OF SVC (25)	21. MOSC (26-39)	22. CIVILIAN OCCUPATION (40-45)	23. UIC CAPTURE UNIT (46-51)
Army	IIA (INF)	FARMER	US-ARA7DD
24. CORPS AREA OF CAPTURE (52)	25. PLACE OF CAPTURE	26. POWER SERVED	27. PLACE OF BIRTH
IV	AB123456	DPRK	KAESONG
28. ADDRESS TO WHICH MAIL FOR PW MAY BE SENT	29. FATHER'S/FATHER	30. MOTHER'S MAIDEN NAME	
3 DONG 5 BAN KAESONG, DPRK	CH'OE, KANG-T'AE	YI, NYONG-CHA	
31. PERMANENT HOME ADDRESS OF PW	32. NAME, ADDRESS, AND RELATIONSHIP OF PERSON TO BE INFORMED OF CAPTURE		
See Item 28.	See Items 29 and 30.		
33. OTHER PARTICULARS FROM ID CARD:			
HT - 1.70 meters HAIR - Black WT - 65 Kilos EYES - Brown Scar on left knee.			
35. IMPOUNDED PERSONAL EFFECTS AND MONEY (24-27)			
26 WON			
THE ABOVE LIST OF IMPOUNDED ITEMS IS CORRECT			
		37. PHOTO	
38. REMARKS		PHOTO (Front View)	
None.		PHOTO (Right Profile)	
39. PREPARED BY (Individual and unit)		39. SIGNATURE	
SFC D.C. SMITH, 17th MP Co.		SFC D.C. Smith	
40. DATE PREPARED	41. PLACE		
8 Oct 99	29th INF DIV REAR INTERNMENT FACILITY		
DA FORM 4237-R, Aug 85 EDITION OF MAY 82 IS OBSOLETE			

Figure 3-1. DA Form 4237-R (Detainee Personnel Record) (front).

FM 34-52

PART II - TO BE MAINTAINED BY UNIT HAVING CUSTODY

42a. LAST NAME CH'OE		b. FIRST NAMES HYON-SIK	
42. INTERNMENT SERIAL NUMBER US-1501-23176			
44. MEDICAL RECORD			
a. IMMUNIZATION (Vaccinations and Inoculations with Dates) Smallpox - 15 APR 98			
b. MAJOR ILLNESSES AND PHYSICAL DEFECTS (With Dates) NONE.			c. BLOOD GROUP B POS
45. INTERNMENT EMPLOYMENT QUALIFICATIONS FARMER			
46. SERIOUS OFFENSES, PUNISHMENTS, AND ESCAPES (With Dates) NONE.			
47. TRANSFERS			
FROM (Location)	TO (Location)	DATE	
48. REMARKS			
49. FINANCIAL STATUS AT TIME OF FIRST INTERNATIONAL TRANSFER			
a. CERTIFICATE OF CREDIT BALANCE ISSUED TO EPW (Amount in words)			b. AMT IN FIGURES
c. LOCATION			d. DATE
50. FINANCIAL STATUS AT TIME OF SECOND INTERNATIONAL TRANSFER			
a. CERTIFICATE OF CREDIT BALANCE ISSUED TO EPW (Amount in words)			b. AMT IN FIGURES
c. LOCATION			d. DATE
51. REPATRIATION			
a. REASON			b. DATE
c. MODE			d. DATE
52. FINANCIAL STATUS AT TIME OF REPATRIATION			
a. CERTIFICATE OF CREDIT BALANCE ISSUED TO EPW (Amount in words)			b. AMT IN FIGURES
c. LOCATION			d. DATE

REVERSE OF DA FORM 4237-R, AUG 84

Figure 3-1. DA Form 4237-R (Detainee Personnel Record) (reverse).

- Possess unusually large amounts of cash or valuables.
- Possess knowledge of critical interest (for example, nuclear power or chemical plant operations, weapons test and development).
- Are illegal border crossers.
- Attempt to avoid checkpoints.
- Are on the black, gray, or white list (FM 34-60A(S)).
- Request to see CI or US Army Intelligence personnel.
- Have family in the denied area.

Screeners should always try to screen cooperative knowledgeable EPWs and detainees first. These include EPWs and detainees identified during the screener's review of documents, questioning of holding area personnel, and their own personal observations. Based on screener notes and recommendations, they establish the order which EPWs and detainees will be questioned. The holding area guards are then told to bring these EPWs and detainees, in order, to the screening site one at a time.

A screener must use a screening report to record information as it is obtained from the source. Figure 3-2 is a format for a screening report. All information shown is rarely obtained from any one source. The blocks save the screener as much additional writing as possible. If PIR, IR, and SIR information is obtained, it is spot reported in SALUTE format. When this type of information is obtained during screening, it must be exploited fully and reported as soon as possible.

Source screening ends when the screener is sure he can make an accurate assessment of the source's potential cooperation and pertinent knowledge. At this time, the source is returned to the control of the guards, and the screener records his assessment on the screening report.

The assessment is recorded using a screening code. The screening code is an alphanumeric designation which reflects the level of cooperation expected from the source and the level of knowledgeability the source may possess. Table 3-1 shows the codes for assessing sources.

Those sources who have been assigned to the same category may be interrogated in any order deemed appropriate by the senior interrogator. Category 1A sources normally should be the first to be interrogated; Category 1B, next; followed by those assigned to categories 2A, 1C, 2B, 3A, 2C, and 3B. Category 3C sources are normally interrogated last.

This order ensures the highest probability of obtaining the greatest amount of pertinent information within available time. Screening codes may change with the echelon. The higher the echelon, the more time is available to conduct an approach.

Figure 3-3 shows the order in which sources will be interrogated. The term "screening category" should not be confused with the categories that are assigned to EPWs and detainees based on their intelligence value.

There are five interrogation phases which take place after the screening process.

- Planning and preparation.

Table 3-1. Instructions for assessing sources.

CODE	COOPERATION LEVEL
1	Responds to direct questions.
2	Responds hesitantly to questioning.
3	Does not respond to questioning.
	KNOWLEDGEABILITY LEVEL
A	Very likely to possess PIR information.
B	Might have IR information.
C	Does not appear to have pertinent information.

FM 34-52

MP NUMBER:		EVACUATION DATE:	
PERSONAL	LNAME (P):	<u>KHRAIS</u>	DATE:
	LNAME (M):		TIME:
	FNAME:	<u>HAITHAM</u>	PLACE:
	MNAME:	<u>ABDULLAH</u>	CAP UNIT:
	SVC/ID NO:	<u>1234567</u>	CIRCUMSTANCES:
	DOB:	<u>24 OCT 80</u>	<u>AFTER FIRE FIGHT</u>
	LANGUAGES:	<u>ARABIC</u>	DOCUMENTS:
MARITAL STATUS:	M <input checked="" type="radio"/> W <input type="radio"/> D <input type="radio"/>	WPNS/EQUIP:	<u>AK-47</u>
*** STATUS:	<input checked="" type="radio"/> Military <input type="radio"/> Civilian <input type="radio"/> Paramilitary <input type="radio"/> Other		
MILITARY	BRANCH:	AF <input checked="" type="radio"/> CG MC NV	PHYSICAL CONDITION:
	RANK:	<u>PVT</u>	SEX:
	FULL UNIT DSG:	<u>1SQD/2PLT/3CO</u>	<input checked="" type="radio"/> M <input type="radio"/> F
	DUTY PSN:	<u>DUTY SOLDIER</u>	WOUNDED:
	JOB:	<u>RIFLEMAN</u>	<input type="radio"/> Y <input checked="" type="radio"/> N
CIVILIAN	STATION:		REMARKS:
	SKILLS:	<u>SHARPSHOOTER</u>	
	EXPERIENCE:	<u>IN SVC 9 Mos.</u>	MENTAL CONDITION:
	JOB:	<u>STUDENT</u>	EDUCATION = <u>8</u> YRS
	ORG:		INTELLIGENCE: <u>AVG + AVG</u> <input checked="" type="radio"/> <u>AVG-</u>
DUTIES:		MENTAL STATE: <u>NERVOUS</u>	
SKILLS:	<u>NONE.</u>	SCREENER:	<u>SFC ROYCE</u>
		DATE:	TIME:
		COOPERATION:	<input checked="" type="radio"/> 1 (High) 2 3 (low)
		KNOWLEDGE:	A (High) <input checked="" type="radio"/> B C (low)
		BGW LIST:	Y <input checked="" type="radio"/> <input type="radio"/> N BGW CODE:
		SOURCE CATEGORY:	A B <input checked="" type="radio"/> C D
		APPROACH:	<u>DIRECT; INCENTIVE</u>
SPECIAL HANDLING REQUIREMENT CODES: _____			
PIR & IIR		REMARKS	

Figure 3-2. Screening report format.

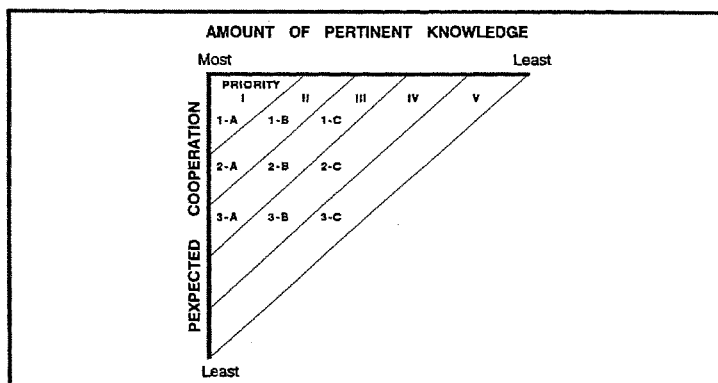

Figure 3-3. Interrogation priorities by screening category.

- Approach.
- Questioning.
- Termination.
- Reporting.

PLANNING AND PREPARATION

Once the senior interrogator has assigned specific sources to his subordinates, the interrogators develop a plan for their interrogations. These plans reflect the supported commander's PIR, IR, and SIR and current tactical situation. If they do not, subsequent interrogations will not help the element to satisfy its assigned collection mission, and information needed by the supported unit will be missed.

Each interrogator, where feasible, begins his preparation by examining the SITMAP, OB data base, and pertinent information contained in the interrogation element's files.

Screening reports (Figure 3-2) and DA Form 5976 (Enemy Prisoner of War Capture Tag) are excellent sources of information the interrogator needs. Figure 3-4 shows a sample of DA Form 5976. There should be at least one of these documents available on each EPW and detainee. Additional sources of information may be—

- Documents captured with the EPW or detainee.
- Reports from interrogation elements at previous echelons.

- DA Form 4237-R (Figure 3-1).

The planning and preparation phase and the approach phase (discussed later) are interrelated. In the planning and preparation phase, the interrogator gathers—

- Information on the source's circumstances of capture.
- Comments from others who have been with the source.
- Information on the source's observed behavior and personal traits.
- Peculiarities from the screening sheet.

This information helps the interrogator develop a picture of the source and enables him to select approaches most likely to work.

There are four primary factors that must be considered when selecting tentative approaches:

- The source's mental and physical state. Is the source injured, angry, crying, arrogant, cocky, or frightened? If so, how can this state be best exploited during interrogation.

FM 34-52

1. DATE AND TIME OF CAPTURE 113002 JAN 91		2. SERIAL NO. XXXXXX1A	
3. NAME STEWART L. HOOD		4. DATE OF BIRTH 12 MAY 56	
5. RANK MAJ	6. SERVICE NO. XXX-XX-XXXX		
7. UNIT OF EPW (122 AND)	8. CAPTURING UNIT REGIMENTAL GUARDS 401ST MP Co.		
9. LOCATION OF CAPTURE (grid coordinates) MA 132456			
10. CIRCUMSTANCES OF CAPTURE - Mass Surrender - Fire Fight - Deserted - Spoke up; etc.	11. CONDITION OF EPW - Wounded; - Broken foot; - Knee injury; etc.	12. WEAPONS, SPECIAL EQUIPMENT, DOCUMENTS Rifle - AK47; Protective Mask; maps, personal papers	

1. DATE AND TIME OF CAPTURE 113002 JAN 91		2. SERIAL NO. XXXXXX1B	
3. NAME STEWART L. HOOD		4. DATE OF BIRTH 12 MAY 56	
5. RANK MAJ	6. SERVICE NO. XXX-XX-XXXX		
7. UNIT OF EPW (122 AND)	8. CAPTURING UNIT REGIMENTAL GUARDS 401ST MP Co.		
9. LOCATION OF CAPTURE (grid coordinates) MA 132456			
10. CIRCUMSTANCES OF CAPTURE - Mass Surrender - Fire Fight - Deserted - Spoke up; etc.	11. CONDITION OF EPW - Wounded; - Broken foot; - Knee injury; etc.	12. WEAPONS, SPECIAL EQUIPMENT, DOCUMENTS Rifle - AK47; Protective Mask; maps, personal papers	

1. DATE AND TIME OF CAPTURE 113002 JAN 91		2. SERIAL NO. XXXXXX1C	
3. NAME STEWART L. HOOD		4. DATE OF BIRTH 12 MAY 56	
5. RANK MAJ	6. SERVICE NO. XXX-XX-XXXX		
7. UNIT OF EPW (122 AND)	8. CAPTURING UNIT REGIMENTAL GUARDS 401ST MP Co.		
9. LOCATION OF CAPTURE (grid coordinates) MA 132456			
10. DESCRIPTION OF WEAPONS, SPECIAL EQUIPMENT, DOCUMENTS AK-47 Rifle, Protective Mask, MAPs, 300 rounds 7.62 Ammunition, 3 flags, blatnoyuzhnik, Personal Papers.			

ENEMY PRISONER OF WAR (EPW) CAPTURE TAG (Part A)
For use of this form, see AR 190-8, the proponent agency is DCSOPS

Attach this part of tag to EPW. (Do not remove from EPW.)

- Search - For weapons, military documents, or special equipment.
- Silence - Prohibit talking among EPWs for ease of control.
- Segregate - By rank, sex, and nationality.
- Safeguard - To prevent harm or escape.
- Speed - Evacuate from the combat zone.
- Tag - Prisoners and documents or special equipment.

DA FORM 5976, JAN 91

UNIT RECORD CARD (Part B)
Attach this part of tag to Unit (Do not remove from unit retains for records.)

Attach this part of tag to EPW's retained property. (Do not remove from property.)

As a minimum, the tag must include the following information:

- Item 1, date and time of capture.
- Item 2, capturing unit.
- Item 9, place of capture (grid coordinates).
- Item 10, circumstances of capture (how the EPW was captured).

DA FORM 5976, JAN 91

Figure 3-4. DA Form 5976 (Enemy Prisoner of War Capture Tag).

- The source's background. What is the source's age and level of military or civilian experience.
- The objective of the interrogation. How much time is available for the interrogation? Is the commander interested only in specific areas (PIR, IR, SIR)? Is this source knowledgeable enough to require a full OB interrogation?
- The interrogator himself. What abilities does he have that can be brought into play? What weaknesses does he have that may interfere with the interrogation? Can his personality adapt to the personality of the source?

The interrogator may require the interrogator conduct research to obtain detailed data on a specific geographic area, political group, weapons system, or technical field. In the technical field, TECHINT personnel assist the interrogator.

There are various weapons identification guides to assist the interrogator in identifying any weapons mentioned by the source. However, the source should not be shown this guide until he has thoroughly described the items, or has drawn a picture of the weapons.

The interrogator may require maps, documents, recording and photographic equipment, screening reports, and other aids to facilitate the interrogation. From these aids, he must select those best suited to accomplish the objective, determine their availability, and arrange for their procurement well in advance of the interrogation. Some aids the interrogator may use are—

- DA Form 5976.
- Previous interrogation reports.
- Documents found on an EPW or detainee or on the battlefield.
- Maps.
- Imagery or aerial photographs.
- OB data.
- Guards.
- CA and PSYOP personnel.
- Informants.
- Physical aids (such as lights, tables, drafting tools).
- Interrogation guides.

The interrogator must consider in advance obstacles and limitations which may affect the interrogation. These obstacles and limitations may include—

- EPW or detainee legal status.
- Time and facilities available for interrogation.
- The military situation.
- Knowledgeability.
- Language restrictions.
- Physical condition.
- Psychological aspects.
- Other issues which may appear during the course of the interrogation.

Logistical requirements include—

- Bilets.
- Office space.
- Heat.
- Light.
- Messing and detention facilities.
- Transportation which may be required in support of the interrogation.

The various staff sections of the supported command may be called upon to furnish the necessary logistical items mentioned above. All support requests will be coordinated with the appropriate staff officer by the EPW or detainee camp or collecting point commander.

Interrogators should question guards about the sources, time permitting, as part of preparation. Since the guards are in constant contact with the sources, they may be able to provide information on—

- Their physical condition.
- Demonstrated attitude and behavior.
- Contact made with other guards or sources.
- How the source has been handled since capture.
- Hearsay (H/S) information from others who have handled the source.
- Confirmation of capture data, especially the circumstances under which the source was captured.

FM 34-52

Time permitting, each interrogator should unobtrusively observe the source to personally confirm his identity and to check his personal appearance and behavior.

After the interrogator has collected all information available about his assigned source, he analyzes it. He looks for indicators of psychological or physical weakness that might make the source susceptible to one or more approaches, which facilitates his approach strategy. He also uses the information he collected to identify the type and level of knowledge possessed by the source pertinent to the element's collection mission.

The interrogator uses his estimate of the type and extent of knowledge possessed by the source to modify the basic topical sequence of questioning. He selects only those topics in which he believes the source has pertinent knowledge. In this way, the interrogator refines his element's overall objective into a set of specific interrogation subjects.

The major topics that can be covered in an interrogation are shown below in their normal sequence. However, the interrogator is free to modify this sequence as necessary.

- Missions.
- Composition.
- Weapons, equipment, strength.
- Dispositions.
- Tactics.
- Training.

APPROACH PHASE

The approach phase begins with initial contact between the EPW or detainee and interrogator. Extreme care is required since the success of the interrogation hinges, to a large degree, on the early development of the EPW's or detainee's willingness to communicate. The interrogator's objective during this phase is to establish EPW or detainee rapport, and to gain his willing cooperation so he will correctly answer pertinent questions to follow. The interrogator—

- Adopts an appropriate attitude based on EPW or detainee appraisal.
- Prepares for an attitude change, if necessary.

- Combat effectiveness.
- Logistics.
- Electronic technical data.
- Miscellaneous.

As a result of the planning and preparation phase, the interrogator develops a plan for conducting his assigned interrogation. He must review this plan with the senior interrogator, when possible. Whether written or oral, the interrogation plan must contain at least the following items:

- Interrogation objective.
- EPW's or detainee's identity, to include visual observation of the EPW or detainee by the interrogator.
- Interrogation time and place.
- Primary and alternate approaches.
- Questioning techniques to be used or why the interrogator selected only specific topics from the basic questioning sequence.
- Means of recording and reporting information obtained.

The senior interrogator reviews each plan and makes any changes he feels necessary based on the commander's PIR and IR. After the plan is approved, the holding compound is notified when to bring the source to the interrogation site. The interrogator collects all available interrogation aids needed (maps, charts, writing tools, and reference materials) and proceeds to the interrogation site.

- Begins to use an approach technique.

The amount of time spent on this phase will mostly depend on the probable quantity and value of information the EPW or detainee possesses, the availability of other EPW or detainee with knowledge on the same topics, and available time. At the initial contact, a businesslike relationship should be maintained. As the EPW or detainee assumes a cooperative attitude, a more relaxed atmosphere may be advantageous. The interrogator must carefully determine which of the various approach techniques to employ.

Regardless of the type of EPW or detainee and his outward personality, he does possess weaknesses which,

if recognized by the interrogator, can be exploited. These weaknesses are manifested in personality traits such as speech, mannerisms, facial expressions, physical movements, excessive perspiration, and other overt indications that vary from EPW or detainee.

From a psychological standpoint, the interrogator must be cognizant of the following behaviors. People tend to—

- Talk, especially after harrowing experiences.
- Show deference when confronted by superior authority.
- Rationalize acts about which they feel guilty.
- Fail to apply or remember lessons they may have been taught regarding security if confronted with a disorganized or strange situation.
- Cooperate with those who have control over them.
- Attach less importance to a topic about which the interrogator demonstrates identical or related experience or knowledge.
- Appreciate flattery and exoneration from guilt.
- Resent having someone or something they respect belittled, especially by someone they dislike.
- Respond to kindness and understanding during trying circumstances.
- Cooperate readily when given material rewards such as extra food or luxury items for their personal comfort.

Interrogators do not "run" an approach by following a set pattern or routine. Each interrogation is different, but all interrogation approaches have the following in common. They—

- Establish and maintain control over the source and interrogation.
- Establish and maintain rapport between the interrogator and source.
- Manipulate the source's emotions and weaknesses to gain his willing cooperation.

The successful application of approach techniques eventually induces the source to willingly provide accurate intelligence information to the interrogator. The term "willingly" refers to the source's answering the

interrogator's questions, not necessarily his cooperation.

The source may or may not be aware he is providing the interrogator with information about enemy forces. Some approaches may be complete when the source begins to answer questions. Others may have to be constantly maintained or reinforced throughout the interrogation.

The techniques used in an approach can best be defined as a series of events, not just verbal conversation between the interrogator and the source. The exploitation of the source's emotion can be harsh or gentle in application. Some useful techniques used by interrogators are—

- Hand and body movements.
- Actual physical contact such as a hand on the shoulder for reassurance.
- Silence.

RAPPORT POSTURES

There are two types of rapport postures determined during planning and preparation: stern and sympathetic.

In the stern posture, the interrogator keeps the EPW or detainee at attention. The aim is to make the EPW or detainee keenly aware of his helpless and inferior status. Interrogators use this posture with officers, NCOs, and security-conscious enlisted men.

In the sympathetic posture, the interrogator addresses the EPW or detainee in a friendly fashion, striving to put him at ease. This posture is commonly used in interrogating older or younger EPWs. EPWs may be frightened and confused. One variation of this posture is when the interrogator asks about the EPW's family. Few EPWs will hesitate to discuss their family.

Frightened persons, regardless of rank, will invariably talk in order to relieve tension once they hear a sympathetic voice in their own tongue. To put the EPW at ease, the interrogator may allow the EPW to sit down, offer a cigarette, ask whether or not he needs medical care, and otherwise show interest in his case.

There are many variations of these basic postures. Regardless of the one used, the interrogator must present a military appearance and show character and energy. The interrogator must control his temper at all times, except when a display is planned. The inter-

FM 34-52

rogator must not waste time in pointless discussions or make promises he cannot keep; for example, the interrogator's granting political asylum.

When making promises in an effort to establish rapport, great care must be taken to prevent implying that rights guaranteed the EPW under international and US law will be withheld if the EPW refuses to cooperate.

Under no circumstances will the interrogator betray surprise at anything the EPW might say. Many EPWs will talk freely if they feel the information they are discussing is already known to the interrogator. If the interrogator acts surprised, the EPW may stop talking immediately.

The interrogator encourages any behavior that deepens rapport and increases the flow of communication. At the same time, the interrogator must discourage any behavior that has the opposite effect.

The interrogator must always be in control of the interrogation. If the EPW or detainee challenges this control, the interrogator must act quickly and firmly. Everything the interrogator says and does must be within the limits of the GPW, Article 17.

DEVELOPING RAPPORT

Rapport must be maintained throughout the interrogation, not only in the approach phase. If the interrogator has established good rapport initially and then abandons the effort, the source would rightfully assume the interrogator cares less and less about him as the information is being obtained. If this occurs, rapport is lost and the source may cease answering questions. Rapport may be developed by—

- Asking about the circumstances of capture. By doing this, the interrogator can gain insight into the prisoner's actual state of mind and, more importantly, he can ascertain his possible breaking points.
- Asking background questions. After asking about the source's circumstances of capture, apparent interest can be built by asking about the source's family, civilian life, friends, likes, and dislikes. This is to develop rapport, but nonpertinent questions may open new avenues for the approach and help determine whether tentative approaches chosen in the planning and preparation phase will be effective. If these questions show that the tentative approaches chosen will not be effective, a flexible

interrogator can shift the approach direction without the source being aware of the change.

Depending on the situation, and requests the source may have made, the interrogator also can use the following to develop rapport.

- Offer realistic incentives, such as—
 - Immediate comfort items (coffee, cigarettes).
 - Short-term (a meal, shower, send a letter home).
 - Long-term (repatriation, political asylum).
- Feign experience similar to those of the source.
- Show concern for the source through the use of voice vitality and body language.
- Help the source to rationalize his guilt.
- Show kindness and understanding toward the source's predicament.
- Exonerate the source from guilt.
- Flatter the source.

After having established control and rapport, the interrogator continually assesses the source to see if the approaches—and later the questioning techniques—chosen in the planning and preparation phase will indeed work.

Approaches chosen in planning and preparation are tentative and based on the sometimes scanty information available from documents, guards, and personal observation. This may lead the interrogator to select approaches which may be totally incorrect for obtaining this source's willing cooperation. Thus, careful assessment of the source is critical to avoid wasting valuable time in the approach phase.

The questions can be mixed or separate. If, for example, the interrogator has tentatively chosen a "love of comrades" approach, he should ask the source questions like "How did you get along with your fellow squad members?" If the source answers they were all very close and worked well as a team, the interrogator can use this approach and be reasonably sure of its success.

However, if the source answers, "They all hated my guts and I couldn't stand any of them," the interrogator should abandon that approach and ask some quick, nonpertinent questions to give himself time to work out a new approach.

Smooth Transitions

The interrogator must guide the conversation smoothly and logically, especially if he needs to move from one approach technique to another. "Poking and hoping" in the approach may alert the prisoner to ploys and will make the job more difficult.

Tie-ins to another approach can be made logically and smoothly by using transitional phrases. Logical tie-ins can be made by including simple sentences which connect the previously used approach with the basis for the next one.

Transitions can also be smoothly covered by leaving the unsuccessful approach and going back to nonpertinent questions. By using nonpertinent conversation, the interrogator can move the conversation in the desired direction and, as previously stated, sometimes can obtain leads and hints about the source's stresses or weaknesses or other approach strategies that may be more successful.

Sincere and Convincing

If an interrogator is using argument and reason to get the source to cooperate, he must be convincing and appear sincere. All inferences of promises, situations, and arguments, or other invented material must be believable. What a source may or may not believe depends on the interrogator's knowledge, experience, and training. A good source assessment is the basis for the approach and vital to the success of the interrogation effort.

Recognize the Breaking Point

Every source has a breaking point, but an interrogator never knows what it is until it has been reached. There are, however, some good indicators the source is near his breaking point or has already reached it. For example, if during the approach, the source leans forward with his facial expression indicating an interest in the proposal or is more hesitant in his argument, he is probably nearing the breaking point. The interrogator must be alert to recognize these signs.

Once the interrogator determines the source is breaking, he should interject a question pertinent to the objective of the interrogation. If the source answers it, the interrogator can move into the questioning phase. If the source does not answer or balks at answering it, the interrogator must realize the source was not as close to the breaking point as thought. In this case, the interrogator must continue with his approach, or switch to an alternate approach or questioning technique and

continue to work until he feels the source is near breaking.

The interrogator can tell if the source has broken only by interjecting pertinent questions. This process must be followed until the EPW or detainee begins to answer pertinent questions. It is possible the EPW or detainee may cooperate for a while and then balk at answering further questions. If this occurs, the interrogator can reinforce the approaches that initially gained the source's cooperation or move into a different approach before returning to the questioning phase.

At this point, it is important to note the amount of time spent with a particular source depends on several factors:

- The battlefield situation.
- Expediency which the supported commander's PIR and IR requirements need to be answered.
- Source's willingness to talk.

The number of approaches used is limited only by the interrogator's skill. Almost any ruse or deception is usable as long as the provisions of the GPW, as outlined in Figure 1-4, are not violated.

An interrogator must not pass himself off as a medic, chaplain, or as a member of the Red Cross (Red Crescent or Red Lion). To every approach technique, there are literally hundreds of possible variations, each of which can be developed for a specific situation or source. The variations are limited only by the interrogator's personality, experience, ingenuity, and imagination.

APPROACH COMBINATIONS

With the exception of the direct approach, no other approach is effective by itself. Interrogators use different approach techniques or combine them into a cohesive, logical technique. Smooth transitions, sincerity, logic, and conviction almost always make a strategy work. The lack of will undoubtedly dooms it to failure. Some examples of combinations are—

- Direct—futility—incentive.
- Direct—futility—love of comrades.
- Direct—fear-up (mild)—incentive.

The number of combinations are unlimited. Interrogators must carefully choose the approach strategy in the planning and preparation phase and listen carefully

FM 34-52

to what the source is saying (verbally or nonverbally) for leads the strategy chosen will not work. When this occurs, the interrogator must adapt to approaches he believes will work in gaining the source's cooperation.

The approach techniques are not new nor are all the possible or acceptable techniques discussed below. Everything the interrogator says and does must be in concert with the GWS, GPW, GC, and UCMI. The approaches which have proven effective are—

- Direct.
- Incentive.
- Emotional.
- Increased fear-up.
- Pride and ego.

Direct Approach

The interrogator asks questions directly related to information sought, making no effort to conceal the interrogation's purpose. The direct approach, always the first to be attempted, is used on EPWs or detainees who the interrogator believes will cooperate.

This may occur when interrogating an EPW or detainee who has proven cooperative during initial screening or first interrogation. It may also be used on those with little or no security training. The direct approach works best on lower enlisted personnel, as they have little or no resistance training and have had minimal security training.

The direct approach is simple to use, and it is possible to obtain the maximum amount of information in the minimum amount of time. It is frequently employed at lower echelons when the tactical situation precludes selecting other techniques, and where the EPW's or detainee's mental state is one of confusion or extreme shock. Figure C-3 contains sample questions used in direct questioning.

The direct approach is the most effective. Statistics show in World War II, it was 90 percent effective. In Vietnam and OPERATIONS URGENT FURY, JUST CAUSE, and DESERT STORM, it was 95 percent effective.

Incentive Approach

The incentive approach is based on the application of inferred discomfort upon an EPW or detainee who lacks willpower. The EPW or detainee may display fondness

for certain luxury items such as candy, fruit, or cigarettes. This fondness provides the interrogator with a positive means of rewarding the EPW or detainee for cooperation and truthfulness, as he may give or withhold such comfort items at his discretion. Caution must be used when employing this technique because—

- Any pressure applied in this manner must not amount to a denial of basic human needs under any circumstances. [NOTE: Interrogators may not withhold a source's rights under the GPW, but they can withhold a source's privileges.] Granting incentives must not infringe on these rights, but they can be things to which the source is already entitled. This can be effective only if the source is unaware of his rights or privileges.
- The EPW or detainee might be tempted to provide false or inaccurate information to gain the desired luxury item or to stop the interrogation.

The GPW, Article 41, requires the posting of the convention contents in the EPW's own language. This is an MP responsibility.

Incentives must seem to be logical and possible. An interrogator must not promise anything that cannot be delivered. Interrogators do not make promises, but usually infer them while sidestepping guarantees.

For example, if an interrogator made a promise he could not keep and he or another interrogator had to talk with the source again, the source would not have any trust and would probably not cooperate. Instead of clearly promising a certain thing, such as political asylum, an interrogator will offer to do what he can to help achieve the source's desired goal; as long as the source cooperates.

As with developing rapport, the incentive approach can be broken down into two incentives. The determination rests on when the source expects to receive the incentive offered.

- Short term—received immediately; for example, letter home, seeing wounded buddies.
- Long term—received within a period of time; for example, political asylum.

Emotional Approach

Through EPW or detainee observation, the interrogator can often identify dominant emotions which motivate. The motivating emotion may be greed, love, hate, revenge, or others. The interrogator employs ver-

bal and emotional ruses in applying pressure to the EPW's or detainee's dominant emotions.

One major advantage of this technique is it is versatile and allows the interrogator to use the same basic situation positively and negatively.

For example, this technique can be used on the EPW who has a great love for his unit and fellow soldiers. The interrogator may take advantage of this by telling the EPW that by providing pertinent information, he may shorten the war or battle in progress and save many of his comrades' lives, but his refusal to talk may cause their deaths. This places the burden on the EPW or detainee and may motivate him to seek relief through cooperation.

Conversely, this technique can also be used on the EPW or detainee who hates his unit because it withdrew and left him to be captured, or who feels he was unfairly treated in his unit. In such cases, the interrogator can point out that if the EPW cooperates and specifies the unit's location, the unit can be destroyed, thus giving the EPW an opportunity for revenge. The interrogator proceeds with this method in a very formal manner.

This approach is likely to be effective with the immature and timid EPW.

Emotional Love Approach. For the emotional love approach to be successful, the interrogator must focus on the anxiety felt by the source about the circumstances in which he finds himself. The interrogator must direct the love the source feels toward the appropriate object: family, homeland, or comrades. If the interrogator can show the source what the source himself can do to alter or improve his situation, the approach has a chance of success.

This approach usually involves some incentive such as communication with the source's family or a quicker end to the war to save his comrades' lives. A good interrogator will usually orchestrate some futility with an emotional love approach to hasten the source's reaching the breaking point.

Sincerity and conviction are critical in a successful attempt at an emotional love approach as the interrogator must show genuine concern for the source, and for the object at which the interrogator is directing the source's emotion.

If the interrogator ascertains the source has great love for his unit and fellow soldiers, the interrogator can ef-

fectively exploit the situation. This places a burden on the source and may motivate him to seek relief through cooperation with the interrogator.

Emotional Hate Approach. The emotional hate approach focuses on any genuine hate, or possibly a desire for revenge, the source may feel. The interrogator must ascertain exactly what it is the source may hate so the emotion can be exploited to override the source's rational side. The source may have negative feelings about his country's regime, immediate superiors, officers in general, or fellow soldiers.

This approach is usually most effective on members of racial or religious minorities who have suffered discrimination in military and civilian life. If a source feels he has been treated unfairly in his unit, the interrogator can point out that, if the source cooperates and divulges the location of that unit, the unit can be destroyed, thus affording the source revenge.

By using a conspiratorial tone of voice, the interrogator can enhance the value of this technique. Phrases, such as "You owe them no loyalty for the way they treated you," when used appropriately, can expedite the success of this technique.

Do not immediately begin to berate a certain facet of the source's background or life until your assessment indicates the source feels a negative emotion toward it.

The emotional hate approach can be used more effectively by drawing out the source's negative emotions with questions that elicit a thought-provoking response. For example, "Why do you think they allowed you to be captured?" or "Why do you think they left you to die?" Do not berate the source's forces or homeland unless certain negative emotions surface.

Many sources may have great love for their country, but may hate the regime in control. The emotional hate approach is most effective with the immature or timid source who may have no opportunity up to this point for revenge, or never had the courage to voice his feelings.

Fear-Up Approach

The fear-up approach is the exploitation of a source's preexisting fear during the period of capture and interrogation. The approach works best with young, inexperienced sources, or sources who exhibit a greater than normal amount of fear or nervousness. A source's fear may be justified or unjustified. For example, a source who has committed a war crime may justifiably fear

FM 34-52

prosecution and punishment. By contrast, a source who has been indoctrinated by enemy propaganda may unjustifiably fear that he will suffer torture or death in our hands if captured.

This approach has the greatest potential to violate the law of war. Great care must be taken to avoid threatening or coercing a source which is in violation of the GPW, Article 17.

It is critical the interrogator distinguish what the source fears in order to exploit that fear. The way in which the interrogator exploits the source's fear depends on whether the source's fear is justified or unjustified.

Fear-Up (Harsh). In this approach, the interrogator behaves in an overpowering manner with a loud and threatening voice. The interrogator may even feel the need to throw objects across the room to heighten the source's implanted feelings of fear. Great care must be taken when doing this so any actions would not violate the prohibition on coercion and threats contained in the GPW, Article 17.

This technique is to convince the source he does indeed have something to fear; that he has no option but to cooperate. A good interrogator will implant in the source's mind that the interrogator himself is not the object to be feared, but is a possible way out of the trap.

Use the confirmation of fear only on sources whose fear is justified. During this approach, confirm to the source that he does indeed have a legitimate fear. Then convince the source that you are the source's best or only hope in avoiding or mitigating the object of his fear, such as punishment for his crimes.

You must take great care to avoid promising actions that are not in your power to grant. For example, if the source has committed a war crime, inform the source that the crime has been reported to the appropriate authorities and that action is pending. Next inform the source that, if he cooperates and tells the truth, you will report that he cooperated and told the truth to the appropriate authorities. You may add that you will also report his lack of cooperation. You may not promise that the charges against him will be dismissed because you have no authority to dismiss the charges.

Fear-Up (Mild). This approach is better suited to the strong, confident type of interrogator; there is generally no need to raise the voice or resort to heavy-handed, table-banging.

For example, capture may be a result of coincidence—the soldier was caught on the wrong side of the border before hostilities actually commenced (he was armed, he could be a terrorist)—or as a result of his actions (he surrendered contrary to his military oath and is now a traitor to his country, and his forces will take care of the disciplinary action).

The fear-up (mild) approach must be credible. It usually involves some logical incentive.

In most cases, a loud voice is not necessary. The actual fear is increased by helping the source realize the unpleasant consequences the facts may cause and by presenting an alternative, which, of course, can be brought about by answering some simple questions.

The fear-up (harsh) approach is usually a dead end, and a wise interrogator may want to keep it in reserve as a trump card. After working to increase the source's fear, it would be difficult to convince him everything will be all right if the approach is not successful.

Fear-Down Approach

This technique is nothing more than calming the source and convincing him he will be properly and humanely treated, or telling him the war for him is mercifully over and he need not go into combat again. When used with a soothing, calm tone of voice, this often creates rapport and usually nothing else is needed to get the source to cooperate.

While calming the source, it is a good idea to stay initially with nonpertinent conversation and to avoid the subject which has caused the source's fear. This works quickly in developing rapport and communication, as the source will readily respond to kindness.

When using this approach, it is important the interrogator relate to the source at his perspective level and not expect the source to come up to the interrogator's level.

If the EPW or detainee is so frightened he has withdrawn into a shell or regressed to a less threatening state of mind, the interrogator must break through to him. The interrogator can do this by putting himself on the same physical level as the source; this may require some physical contact. As the source relaxes and begins to respond to kindness, the interrogator can begin asking pertinent questions.

This approach technique may backfire if allowed to go too far. After convincing the source he has nothing

to fear, he may cease to be afraid and may feel secure enough to resist the interrogator's pertinent question. If this occurs, reverting to a harsher approach technique usually will bring the desired result quickly.

The fear-down approach works best if the source's fear is unjustified. During this approach, take specific actions to reduce the source's unjustified fear. For example, if the source believes that he will be abused while in your custody, make extra efforts to ensure that the source is well cared for, fed, and appropriately treated.

Once the source is convinced that he has no legitimate reason to fear you, he will be more inclined to cooperate. The interrogator is under no duty to reduce a source's unjustified fear. The only prohibition is that the interrogator may not say or do anything that directly or indirectly communicates to the source that he will be harmed unless he provides the requested information.

These applications of the fear approach may be combined to achieve the desired effect. For example, if a source has justified and unjustified fears, you may initially reduce the source's unfounded fears, then confirm his legitimate fears. Again, the source should be convinced the interrogator is his best or only hope in avoiding or mitigating the object of his fear.

Pride and Ego Approach

The strategy of this approach is to trick the source into revealing desired information by goading or flattering him. It is effective with sources who have displayed weakness or feelings of inferiority. A real or imaginary deficiency voiced about the source, loyalty to his organization, or any other feature can provide a basis for this technique.

The interrogator accuses the source of weakness or implies he is unable to do a certain thing. This type of source is also prone to excuses and reasons why he did or did not do a certain thing, often shifting the blame to others. An example is opening the interrogation with the question, "Why did you surrender so easily when you could have escaped by crossing the nearby ford in the river?"

The source is likely to provide a basis for further questions or to reveal significant intelligence information if he attempts to explain his surrender in order to vindicate himself. He may give an answer such as, "No one could cross the ford because it is mined."

This technique can also be employed in another manner—by flattering the source into admitting certain information in order to gain credit. For example, while interrogating a suspected saboteur, the interrogator states: "This was a smooth operation. I have seen many previous attempts fail. I bet you planned this. Who else but a clever person like you would have planned it? When did you first decide to do the job?"

This technique is especially effective with the source who has been looked down upon by his superiors. The source has the opportunity to show someone he is intelligent.

A problem with the pride and ego approach is it relies on trickery. The source will eventually realize he has been tricked and may refuse to cooperate further. If this occurs, the interrogator can easily move into a fear-up approach and convince the source the questions he has already answered have committed him, and it would be useless to resist further.

The interrogator can mention it will be reported to the source's forces that he has cooperated fully with the enemy, will be considered a traitor, and has much to fear if he is returned to his forces.

This may even offer the interrogator the option to go into a love-of-family approach where the source must protect his family by preventing his forces from learning of his duplicity or collaboration. Telling the source you will not report that he talked or that he was a severe discipline problem is an incentive that may enhance the effectiveness of the approach.

Pride and Ego-Up Approach. This approach is most effective on sources with little or no intelligence, or on those who have been looked down upon for a long time. It is very effective on low-ranking enlisted personnel and junior grade officers, as it allows the source to finally show someone he does indeed have some "brains."

The source is constantly flattered into providing certain information in order to gain credit. The interrogator must take care to use a flattering somewhat-in-awe tone of voice, and speak highly of the source throughout this approach. This quickly produces positive feelings on the source's part, as he has probably been looking for this type of recognition all of his life.

The interrogator may blow things out of proportion using items from the source's background and making them seem noteworthy or important. As everyone is eager to hear praise, the source will eventually reveal

FM 34-52

pertinent information to solicit more laudatory comments from the interrogator.

Effective targets for a successful pride and ego-up approach are usually the socially accepted reasons for flattery, such as appearance and good military bearing. The interrogator should closely watch the source's demeanor for indications the approach is working. Some indications to look for are—

- Raising of the head.
- A look of pride in the eyes.
- Swelling of the chest.
- Stiffening of the back.

Pride and Ego-Down Approach. This approach is based on attacking the source's sense of personal worth. Any source who shows any real or imagined inferiority or weakness about himself, loyalty to his organization, or captured under embarrassing circumstances, can be easily broken with this approach technique.

The objective is for the interrogator to pounce on the source's sense of pride by attacking his loyalty, intelligence, abilities, leadership qualities, slovenly appearance, or any other perceived weakness. This will usually goad the source into becoming defensive, and he will try to convince the interrogator he is wrong. In his attempt to redeem his pride, the source will usually involuntarily provide pertinent information in attempting to vindicate himself.

A source susceptible to this approach is also prone to make excuses and give reasons why he did or did not do a certain thing, often shifting the blame to others. If the interrogator uses a sarcastic, caustic tone of voice with appropriate expressions of distaste or disgust, the source will readily believe him. Possible targets for the pride and ego-down approach are the source's—

- Loyalty.
- Technical competence.
- Leadership abilities.
- Soldierly qualities.
- Appearance.

The pride and ego-down approach is also a dead end in that, if unsuccessful, it is difficult for the interrogator to recover and move to another approach and rees-

tablish a different type of rapport without losing all credibility.

Futility

In this approach, the interrogator convinces the source that resistance to questioning is futile. When employing this technique, the interrogator must have factual information. These facts are presented by the interrogator in a persuasive, logical manner. He should be aware of and able to exploit the source's psychological and moral weaknesses, as well as weaknesses inherent in his society.

The futility approach is effective when the interrogator can play on doubts that already exist in the source's mind. There are different variations of the futility approach. For example:

- Futility of the personal situation—"You are not finished here until you answer the questions."
- Futility in that "everyone talks sooner or later."
- Futility of the battlefield situation.
- Futility in the sense if the source does not mind talking about history, why should he mind talking about his missions, they are also history.

If the source's unit had run out of supplies (ammunition, food, or fuel), it would be somewhat easy to convince him all of his forces are having the same logistical problems. A soldier who has been ambushed may have doubts as to how he was attacked so suddenly. The interrogator should be able to talk him into believing that the interrogator's forces knew of the EPW's unit location, as well as many more units.

The interrogator might describe the source's frightening recollections of seeing death on the battlefield as an everyday occurrence for his forces. Factual or seemingly factual information must be presented in a persuasive, logical manner, and in a matter-of-fact tone of voice.

Making the situation appear hopeless allows the source to rationalize his actions, especially if that action is cooperating with the interrogator. When employing this technique, the interrogator must not only have factual information but also be aware of and exploit the source's psychological, moral, and sociological weaknesses.

Another way of using the futility approach is to blow things out of proportion. If the source's unit was low on, or had exhausted, all food supplies, he can be easily

led to believe all of his forces had run out of food. If the source is hinging on cooperating, it may aid the interrogation effort if he is told all the other source's have cooperated.

The futility approach must be orchestrated with other approach techniques (for example, love of comrades). A source who may want to help save his comrades' lives may be convinced the battlefield situation is hopeless and they will die without his assistance.

The futility approach is used to paint a bleak picture for the prisoner, but it is not effective in and of itself in gaining the source's cooperation.

We Know All

This approach may be employed in conjunction with the "file and dossier" technique (discussed below) or by itself. If used alone, the interrogator must first become thoroughly familiar with available data concerning the source. To begin the interrogation, the interrogator asks questions based on this known data. When the source hesitates, refuses to answer, or provides an incorrect or incomplete reply, the interrogator provides the detailed answer.

When the source begins to give accurate and complete information, the interrogator interjects questions designed to gain the needed information. Questions to which answers are already known are also asked to test the source's truthfulness and to maintain the deception that the information is already known. By repeating this procedure, the interrogator convinces the source that resistance is useless as everything is already known.

After gaining the source's cooperation, the interrogator still tests the extent of cooperation by periodically using questions to which he has the answers; this is very necessary. If the interrogator does not challenge the source when he is lying, the source will know everything is not known, and he has been tricked. He may then provide incorrect answers to the interrogator's questions.

There are some inherent problems with the use of the "we know all" approach. The interrogator is required to prepare everything in detail, which is time consuming. He must commit much of the information to memory, as working from notes may show the limits of the information actually known.

File and Dossier

The file and dossier approach is used when the interrogator prepares a dossier containing all available information obtained from documents concerning the source or his organization. Careful arrangement of the material within the file may give the illusion it contains more data than actually there. The file may be padded with extra paper, if necessary. Index tabs with titles such as education, employment, criminal record, military service, and others are particularly effective.

The interrogator confronts the source with the dossiers at the beginning of the interrogation and explains intelligence has provided a complete record of every significant happening in the source's life; therefore, it would be useless to resist. The interrogator may read a few selected bits of known data to further impress the source.

If the technique is successful, the source will be intimidated by the size of the file, conclude everything is known, and resign himself to complete cooperation. The success of this technique is largely dependent on the naivete of the source, volume of data on the subject, and skill of the interrogator in convincing the source.

Establish Your Identity

This approach is especially adaptable to interrogation. The interrogator insists the source has been correctly identified as an infamous individual wanted by higher authorities on serious charges, and he is not the person he purports to be. In an effort to clear himself of this allegation, the source makes a genuine and detailed effort to establish or substantiate his true identity. In so doing, he may provide the interrogator with information and leads for further development.

The "establish your identity" approach was effective in Viet Nam with the Viet Cong and in OPERATIONS JUST CAUSE and DESERT STORM.

This approach can be used at tactical echelons. The interrogator must be aware if it is used in conjunction with the file and dossier approach, as it may exceed the tactical interrogator's preparation resources.

The interrogator should initially refuse to believe the source and insist he is the criminal wanted by the ambiguous higher authorities. This will force the source to give even more detailed information about his unit in order to convince the interrogator he is who he says he is. This approach works well when combined with the "futility" or "we know all" approach.

FM 34-52

Repetition

This approach is used to induce cooperation from a hostile source. In one variation of this approach, the interrogator listens carefully to a source's answer to a question, and then repeats the question and answer several times. He does this with each succeeding question until the source becomes so thoroughly bored with the procedure he answers questions fully and candidly to satisfy the interrogator and gain relief from the monotony of this method.

The repetition technique must be judiciously used, as it will generally be ineffective when employed against introverted sources or those having great self-control. In fact, it may provide an opportunity for a source to regain his composure and delay the interrogation. In this approach, the use of more than one interrogator or a tape recorder has proven effective.

Rapid Fire

This approach involves a psychological ploy based upon the principles that—

- Everyone likes to be heard when he speaks.
- It is confusing to be interrupted in mid-sentence with an unrelated question.

This approach may be used by one or simultaneously by two or more interrogators in questioning the same source. In employing this technique, the interrogator asks a series of questions in such a manner that the source does not have time to answer a question completely before the next one is asked.

This confuses the source and he will tend to contradict himself, as he has little time to formulate his answers. The interrogator then confronts the source with the inconsistencies causing further contradictions.

In many instances, the source will begin to talk freely in an attempt to explain himself and deny the interrogator's claims of inconsistencies. In this attempt, the source is likely to reveal more than he intends, thus creating additional leads for further exploitation. This approach may be orchestrated with the pride and ego-down or fear-up approaches.

QUESTIONING PHASE

The interrogation effort has two primary goals: To obtain information and to report it. Developing and using good questioning techniques enable the inter-

Besides extensive preparation, this approach requires an experienced and competent interrogator, with comprehensive case knowledge and fluency in the source's language.

Silent

This approach may be successful when used against the nervous or confident source. When employing this technique, the interrogator says nothing to the source, but looks him squarely in the eye, preferably with a slight smile on his face. It is important not to look away from the source but force him to break eye contact first.

The source may become nervous, begin to shift in his chair, cross and recross his legs, and look away. He may ask questions, but the interrogator should not answer until he is ready to break the silence. The source may blurt out questions such as, "Come on now, what do you want with me?"

When the interrogator is ready to break silence, he may do so with some nonchalant questions such as, "You planned this operation for a long time, didn't you? Was it your idea?" The interrogator must be patient when using this technique. It may appear the technique is not succeeding, but usually will when given a reasonable chance.

Change of Scene

The idea in using this approach is to get the source away from the atmosphere of an interrogation room or setting. If the interrogator confronts a source who is apprehensive or frightened because of the interrogation environment, this technique may prove effective.

In some circumstances, the interrogator may be able to invite the source to a different setting for coffee and pleasant conversation. During the conversation in this more relaxed environment, the interrogator steers the conversation to the topic of interest. Through this somewhat indirect method, he attempts to elicit the desired information. The source may never realize he is being interrogated.

Another example in this approach is an interrogator poses as a compound guard and engages the source in conversation, thus eliciting the desired information.

rogator to obtain accurate and pertinent information by following a logical sequence.

The questioning phase starts when the source begins to answer questions pertinent to interrogation objectives.

QUESTIONING TECHNIQUES

Good questioning techniques must be used throughout the interrogation. The interrogator must know when to use different types of questions. Good questioning techniques enable the interrogator to extract the maximum amount of information in the minimum amount of time. The interrogator must be able to use the following types of questions:

- Direct.
- Follow-up.
- Nonpertinent.
- Repeated.
- Control.

- Prepared.

Direct Questions

Questions should be presented in a logical sequence to avoid neglecting significant topics. A series of questions following a chronological sequence of events is frequently employed, but this is not the only logical method of asking questions. Adherence to a sequence should not deter the interrogator from exploiting informational leads as they are obtained.

The interrogator must consider the probable response of the source to a particular question or line of questioning and should not, if at all possible, ask direct questions likely to evoke a refusal to answer or to antagonize the source.

Experience has shown that in most tactical interrogations, the source is cooperative. In such instances, the interrogator should proceed with direct questions. Good, direct questions—

(CLASSIFICATION)	
SPOT REPORT	
TO: G2, X Corps	DATE: 171105FEB99
FROM: Team 2, IPW Section, 213th MI Bn 25th Div (Armd), X Corps	REPORT NO: 02-314
1. SIZE/WHO: Squad.	
2. ACTIVITY/WHAT: Reconnaissance.	
3. LOCATION/WHERE: NB 576472 (Hwy intersection).	
4. UNIT/WHO: 1 MRS/3 MRC/2 MRB/44 MRR/56 MRD.	
5. TIME/WHEN: No later than 171800FEB99.	
6. EQUIPMENT/HOW: Using assigned weapons and equipment, recon forward areas to determine avenues of approach for elements of 2 MRB.	
7. REMARKS:	
a. SOURCE: EPW, Interrogation serial number US-AR-23.035-73.	
b. MAP DATA: GERMANY, EISENACH-HUNFELD, 1:50,000, USACGSC 50-242, Edition 5.	
c. H/S, CPT ANRUF, CO, 3 MRC/2 MRB/44 MRR/56 MRD, DOI: 170100FEB99.	
(CLASSIFICATION)	

Figure 3-5. Sample spot report (SALUTE).

FM 34-52

- Begin with a basic interrogative: Who, What, When, Where, Why, and How.
- Require a narrative answer. One which cannot be answered by a simple Yes or No. This type of question requires the source to think about his answer in order to respond correctly.
- Provide a maximum amount of information in the least amount of time, and the greatest number of leads to other information.
- Are brief, precise, and simply worded to avoid confusion.

(NOTE: The source may not be on the same intellectual level as the interrogator and some may be illiterate. Some words or phrases in English do not translate into a foreign language.)

Follow-Up Questions

Follow-up questions are used to obtain complete information on a topic that pertains to the interrogation objective. They are used to exploit leads obtained from the source on information not directly related to the primary interrogation objective. Exploitation of these leads is discussed later. There are two types of leads:

- Hot—information that could affect the immediate tactical situation in your AO. This type of lead should be exploited immediately, and a spot report submitted as soon as possible. Figure 3-5 is a sample of a spot report in a SALUTE format.
- Cold—information of intelligence value that will not affect the immediate tactical situation. This type of lead is recorded and exploited after the interrogation objective has been satisfied or at the appropriate time during the interrogation sequence.

Nonpertinent Questions

Nonpertinent questions are used to conceal the interrogation's objectives or to strengthen rapport with the source. They may also be used to break the source's concentration, particularly, if the interrogator suspects the source is lying. It is hard for a source to be a convincing liar if his concentration is frequently interrupted.

Repeated Questions

Repeated questions ask the source for the same information obtained in response to earlier questions. They may be exact repetitions of the previous question, or the

previous question may be rephrased or otherwise disguised. The use of repeated questions may develop a topic the source had refused to talk about earlier. Repeated questions may also be used to—

- Check source reliability.
- Ensure accuracy of important details such as place names, dates, and component parts of technical equipment.
- Return to a topical area for further questioning.

Control Questions

Control questions are developed from recently confirmed information that is not likely to have changed. They are used to check the truthfulness of the source's responses and should be mixed in with other questions throughout the interrogation.

Prepared Questions

Prepared questions are used primarily when dealing with information of a technical nature, or specific topic, which requires the interrogator to formulate questions beforehand; the interrogator prepares them in writing to be used during the interrogation. The interrogator may have to research technical material or contact TECHINT personnel to assist him in preparing questions. Interrogators must not allow the use of prepared questions to restrict the scope and flexibility of their interrogations.

The interrogator must use the different type of questions effectively. Active listening and maximum eye-to-eye contact with the source will provide excellent indicators for when to use follow-up, repeated, control, and nonpertinent questions.

The interrogator must use direct and follow-up questions to fully exploit subjects pertinent to his interrogation objectives. He should periodically include control, repeated, and nonpertinent questions in order to check the sincerity and consistency of the source's responses and to strengthen rapport.

A response which is inconsistent with earlier responses or the interrogator's available data is not necessarily a lie. When such a response is obtained, the interrogator should reveal the inconsistency to the source and ask for an explanation. The source's truthfulness should then be evaluated based on the plausibility of his explanation.

QUESTIONS TO AVOID

Interrogators should avoid the following types of questions.

Leading Questions

Leading questions require the source to answer Yes or No. They do not elicit narrative answers. They also prompt the source to answer the question in a way he thinks the interrogator wants to hear it; for example, "Did you go to the command post last night?" Although normally avoided during the interrogation, leading questions may be used to—

- Verify facts.
- Pinpoint map locations.
- Confirm information obtained during map tracking. Leading questions are used sparingly during map tracking.

Negative Questions

Negative questions should never be used during an interrogation. They imply the source should reply in the negative, and this sometimes confuses or leads the source to provide false information; for example, "You're not in the 1st Company, are you?" Negative questions usually require additional questions to clarify the source's responses.

Compound Questions

Compound questions are never used during an interrogation. They are two questions asked at the same time; for example, "Before you were captured today, were you traveling north or south?" They are easily misunderstood and may confuse the source or force him to give an ambiguous answer. Compound questions allow the source to evade a part of the question or to give an incomplete answer. They may confuse the source or cause the interrogator to misunderstand the response.

Vague Questions

Vague questions do not have enough information for the source to understand exactly what is being asked by the interrogator. They may be incomplete, general, or otherwise nonspecific and create doubt in the source's mind. Vague questions confuse the source, waste time, are easily evaded, and result in answers that may confuse or mislead the interrogator.

INTERROGATORS GUIDE

An Interrogators Guide is a pamphlet or notebook designed to guide the interrogator through the interrogation. The IPW senior interrogator should ensure team members prepare an interrogators guide, which could be included in the unit's SOP. The guides are made based on the AO and supported command intelligence requirements. They should be jointly prepared by the interrogator and available intelligence analysts. The guides contain information such as—

- PIR and IR.
- Topical sequence question format.
- Actual prepared questions to be used during the interrogation.
- Guidelines for employing the various approach techniques.
- Formats or samples of completed interrogation reports used by interrogators.

SPOT REPORTABLE INFORMATION

Spot reportable information is critical to the successful accomplishment of friendly COAs. Information may be spot reportable even when an interrogator cannot determine its immediate intelligence value. Spot reportable information is always time sensitive in that its value depends on the speed with which it is reported and processed.

If an interrogator obtains information he thinks is spot reportable, he must compare the information with his element's overall objective statement. Items of information relating to any of the intelligence indicators listed in the objective statement are spot reportable. Information relating to indicators not listed may still be spot reportable.

The key to identifying spot reportable information is recognizing its potential value. If the information indicates a significant change in the enemy's capabilities or intentions, it is spot reportable. Information inconsistent with current OB holdings should be spot reported if the inconsistency concerns an important item and the source has given a plausible explanation for it.

If an interrogator cannot decide if a piece of information is spot reportable, he should act as though it is. This means he should exploit it fully and record all pertinent information. The interrogator should then consult the senior interrogator for a final determination of

FM 34-52

the information's value. Spot reportable information is transmitted by the interrogator either written or orally in the SALUTE format (Figure 3-5).

LEADS

Leads are signs which tell the interrogator the source has additional pertinent information that can be obtained through further questioning. Hot and cold leads are provided by a source in response to interrogator questions.

A hot lead, when exploited, may obtain spot reportable information. A cold lead, when exploited, may obtain information not spot reportable, but still of intelligence value.

The use of follow-up questions to fully exploit hot and cold leads may require an interrogator to cover topics he did not list in his interrogation plan. An interrogator must exploit hot leads as soon as he identifies them.

Once the interrogator is sure he has obtained and recorded all the details known to the source, he issues a spot report. The interrogator then resumes his questioning of the source at the same point where the hot lead was obtained. An interrogator should note cold leads as they are obtained, and exploit them fully during his questioning on the topics to which the cold lead apply.

Cold leads may expand the scope of the interrogation because they may indicate the source possesses pertinent information in areas not previously selected for questioning. If the interrogator does not fully exploit all cold leads he obtains, he must include information on all leads he did not exploit in his interrogation report.

HEARSAY INFORMATION

H/S information must include the most precise data possible of its source. This will include—

- Name, rank, and duty position.
- Full unit designation of the person who provided the information.
- Date-time group (DTG) when the source obtained the information.

QUESTIONING SEQUENCE

The interrogator begins the questioning phase with the first topic in the sequence he tentatively established as part of his interrogation plan. He obtains all the

source's pertinent knowledge in this topical area before moving on to the next topic in his sequence. He maintains his established questioning sequence to ensure no topics are missed. The only exception is exploiting a hot lead.

Map Tracking

During the questioning phase, the interrogator will attempt to pinpoint locations of any enemy dispositions known to the source. He will attempt to determine the whereabouts of the source, and will compare the source's description of terrain features with maps, aerial photographs, and pictomaps. Some map tracking advantages are—

- The source is led through his memory in a logical manner.
- A valid reliability scale can be determined by comparing the source's information with a map or aerial photographs.
- Discrepancies in the source's statements are easier to detect.

The interrogator asks the source if he can read the map being used. If so, he should be asked to show the location of routes and dispositions. If the source cannot read the interrogator's map, he must be asked if he knows compass directions. If not, the interrogator must explain them to him. This can be done by having the source picture himself facing the rising or setting sun and then establishing compass points.

The interrogator may find the source is most confident when expressing himself in terms other than compass directions. When this happens, the interrogator should allow the source to use his own frames of reference. However, the interrogator must ensure he understands the source.

The first location the interrogator should try to establish as the initial common point of reference (ICPR) is the source's POC. The POC cannot be used, however, unless the source can describe it well enough for the interrogator to be certain of its location. If the POC cannot be used, the interrogator must review locations previously mentioned by the source and ask him to describe each of them in turn.

Once the source describes a location well enough for the interrogator to be certain of its position on the map, an ICPR has been established. The interrogator then marks that position.

The interrogator reviews the source's past missions to identify those points he actually visited. The interrogator determines how long ago the source was at each point, and approximately how far each point is from the ICPR.

The interrogator wants to select as the destination common point of reference (DCPR) that point visited by the source which provides the longest route of travel to the ICPR, and is still within the supported command's AI. The DCPR selected must be a location the source can describe well enough for it to be plotted on the map, even if it is nothing more than a general vicinity.

Establish a Route

The interrogator establishes the route the source traveled between the DCPR and ICPR. When the DCPR is a specific point, the interrogator can establish the route from it to the ICPR, tracing the route in the same direction which the source actually traveled.

When the DCPR is an undefined point, the interrogator establishes the route from ICPR to the DCPR. This means the interrogator must trace the route in the opposite direction from that traveled by the source. The interrogator should establish the route traveled by using the following procedures in the sequence shown:

- Obtain the direction in which the source would travel when leaving the ICPR.
- Obtain a description of the surface on which the source would be traveling.
- Obtain the distance the source would travel in this direction.
- Obtain a description of the prominent terrain features the source would remember while traveling in this direction.
- Repeat the questions and plot responses until the entire route between the ICPR and DCPR has been plotted.

The interrogator can follow the same sequence when establishing the route actually traveled by the source by beginning with the DCPR.

Exploit the DCPR

The interrogator must obtain the exact location and description of each enemy disposition the source knew about at the DCPR. The interrogator does this by having the source—

- Identify and describe all items of military significance belonging to his forces which are located at the DCPR.
- Provide the full unit designation of enemy units to which these items belong.
- Identify and describe all collocated enemy units.
- Describe security measures employed at each identified disposition.
- Identify the source of his information.
- Provide the date and time he obtained his information.
- Provide name, rank, duty position, and full unit designation of each person who provided H/S information to the source.

The interrogator must repeat these questions, and plot or record the information as it is provided by the source, until he obtains all dispositions known by the source to be in the vicinity of the DCPR.

Segment and Exploit the Route

The interrogator begins exploiting the source's route with the segment closest to the ICPR or DCPR. The interrogator will segment closest to the DCPR, but either can be used.

The interrogator will exploit each segment of the route by asking the question: "From (description of common point of reference [(CPR)] to (description of next CPR) back along your route of travel, what of military significance belonging to your forces do you know of, have seen, or heard?" The interrogator will continue from segment to segment, fully exploiting each, until he has exploited the entire route traveled.

Exploit Dispositions Not On Route

If the interrogator obtains a disposition which is not located on the established route, he must establish the route the source would have taken to that disposition. The interrogator then treats this new route the same way he does any other route segment, exploiting it fully before moving on to the next segment of the original route.

The sequence above organizes map tracking so information obtained from the source can be plotted and recorded accurately. The description of each disposition must be recorded preferably near the site of the disposition on the map.

FM 34-52

Recording Information

There are several reasons for recording information obtained during interrogations. The most important is to ensure information can be reported completely and accurately. Recorded information may also be used to—

- Refresh the interrogator's memory on a topic covered earlier, such as when returning to a topic after exploiting a hot lead.
- Check responses to repeated questions.
- Point out inconsistencies to the source.
- Gain the cooperation of other sources.
- Compare with information received from other sources.

Taking Notes

There are several methods of recording information used during interrogations. Two are listed below, along with their advantages and disadvantages. These methods may be used separately, or in combination with each other.

Using His Own Notes. The interrogator's own notes are the primary method of recording information. When the interrogator takes his own notes, he has a ready reference to verify responses to repeated questions or to refresh his memory. They also provide him with the means to record cold leads for later exploitation.

Using his own notes expedites the interrogator's accurate transferral of information into a report format. When taking his own notes, however, he cannot observe the source continuously. This may cause him to miss leads or fail to detect losses in rapport or control that are detectable only through clues provided by the source's behavior.

It is possible to lose control, and the source's willing cooperation, by concentrating too much on note taking. The interrogator must avoid distracting the source while taking notes. They should be taken in such a way that maintains maximum eye-to-eye contact with the source.

TERMINATION PHASE

When it is necessary or prudent, the interrogator will terminate the interrogation. There are many ways to conduct a termination, but the following points must be conveyed to the source:

The interrogator will not have enough time to record each word the source says. Thus, he must—

- Be able to summarize information into a few words.
- Use past experiences to decide which items of information should be recorded.
- Organize his materials to avoid having to flip back and forth between references.

The only information that should be recorded during the approach phase is that required by Part I of DA Form 4237-R (Figure 3-1). All other information should not be recorded until after the source's cooperation has been obtained.

All notes must be complete, accurate, and legible. Notes should be organized by topical areas. A separate piece of paper should be used to record cold leads. The interrogator should use authorized military abbreviations and brevity codes (see AR 310-50). Notes should be in a recognizable format and complete for other interrogators to use. Situations may arise that require one interrogator to finish another's interrogation.

Using a Sound or Video Recorder. This method allows the interrogator to continually observe the source. When compared with note taking, this method allows more information to be obtained in less time. However, more time is required for report writing because the entire tape must be replayed to transfer information to the report.

Record names, numbers, and other pertinent, detailed information that may be unclear on the tape. Sound recorders cannot provide a quick reference that can be used to compare answers to a repeated question, and the equipment may malfunction.

Another method which has proven successful during exercises is to have linguist qualified intelligence analysts view interrogations or debriefings by using video cameras and monitors. This method allows the intelligence analyst to immediately pass additional questions to the interrogator to follow up on possible source knowledge.

- The approaches used to "break" the source must be reinforced. Any promised incentives should be rendered. The reinforcement must be sincere and

EPW IDENTITY CARD <small>For use of this form, see AR 190-8; the proponent agency is DCSPEA</small>		DATE ISSUED 8 OCT 99	
(Photograph)	LAST NAME CH'OE		GRADE Sr SGT
	FIRST NAME HYON-SIK		POWER SERVED DPRK
	SERVICE NUMBER 5611642		DATE OF BIRTH 24 FEB 67
PLACE OF BIRTH KAESONG		SIGNATURE OF BEARER 	
DA FORM 2662-R, May 82 EDITION OF 1 JUL 83 IS OBSOLETE.			

IDENTIFICATION MARKS OF	LEFT INDEX	WEIGHT 65 K	COLOR OF EYES BROWN
		HEIGHT 1.70 m	COLOR OF HAIR BLACK
		BLOOD TYPE B POS	RELIGION NONE
		NOTICE	
		This card is issued to prisoners of war in the custody of the United States Army. This card must be carried at all times by the EPW to whom it is issued.	
IDENTIFICATION MARKS OF	RIGHT INDEX	REVERSE	

Reverse of DA Form 2662-R, May 82

Figure 3-6. DA Form 2662-R (United States Army EPW Identification Card).

FM 34-52

convincing, as the source may be interrogated again.

- The source must be told the information he gave will be checked for truthfulness and accuracy. His reaction to this statement should be closely monitored.
- The source must be told he will be spoken to again by the same or another interrogator.
- Any identification or other documents, personal property, or other material must be returned to the source or be given to the evacuation guard, as appropriate.

REASONS FOR TERMINATION

Some reasons for termination are—

- The source remains uncooperative during the approach phase.
- The source could be wounded, sick, or elderly, and his condition might force the interrogator to terminate until a later time.
- The interrogation objective requires several questioning periods to obtain all the information.
- The source may change his attitude during the interrogation, and may become more alert, belligerent, bored, or too talkative, thus indicating termination until later.
- The interrogator fails to maintain rapport and loses control of the interrogation.
- Interrogation objectives have been satisfied.
- The interrogator becomes physically or mentally unable to continue.
- Information possessed by the source is of such value his immediate evacuation to the next echelon is required.

REPORTING INFORMATION

The last portion of the interrogation process is reporting information obtained. The most brilliantly executed interrogation becomes a wasted effort if not reported properly. To aid military operations, information obtained must be transmitted as quickly as the situation permits in a usable form to an agency capable of taking action.

- The interrogator's presence is required elsewhere.

TERMINATION PROCEDURES

Whatever the reason for terminating, the interrogator must remember there is a possibility someone may want to question the source at a later date. For that reason, he should terminate without any loss of rapport when possible. He offers the opportunity for the source to change or add to any information he has given.

During termination, the interrogator must properly dispose of any documents captured with the source. A source's military identity document must be returned to him.

If a source does not hold an identity card issued by his government, the MP will issue a DA Form 2662-R (United States Army EPW Identification Card). This form, shown at Figure 3-6, will accompany the source at all times. AR 190-8 is the prescribing directive of this form.

Some captured documents will contain information that must be exploited at higher echelons. These documents may be impounded by the interrogator and evacuated through intelligence channels. The interrogator must issue a receipt to the source for any personal documents he decides to impound. He must comply with the accounting procedures established for captured documents by the MP in accordance with AR 190-8.

These procedures are time-consuming but necessary. The interrogator can save time by preparing receipts and document tags during the planning and preparation phase.

The interrogator completes the termination phase by instructing the escort guard to return the source to the holding compound and to keep him away from sources who have not been interrogated.

Although the interrogator normally takes notes during the interrogation, he will have to rely on his memory, to some degree, while reporting information received from the source. The more distractions that occur between the interrogation and the reporting, the greater the chance the interrogator will lose some of the information obtained. The reporting normally is done in the format appropriate for the information being reported.

3-28

Appendix E contains formats of reports. Initial reports are submitted electronically when possible to ensure the information reaches the intelligence analysts in the least amount of time.

Written reports are prepared to document electronic reports. They are used as initial means of reporting only when electronic reporting is impossible. Any information of intelligence value that will diminish with the passage of time must be SALUTE reported.

Electronic SALUTE reports are formatted and submitted according to the procedures established during the senior interrogator's initial coordination. Information not SALUTE reportable is electronically reported with a lower priority.

The aim of any interrogation is to obtain information which will help satisfy a commander's intelligence requirements. Since these requirements will differ in scope at each level, when conducting PIR or IR interrogations, nonapplicable paragraphs may be deleted. Part I must always be included and distribution made according to STANAG 2033.

Regardless of the report format used, information must be reported accurately according to the following criteria:

- Each item of information reported which has a different date of information from the overall report must be accompanied by its correct date.

INTERROGATION WITH AN INTERPRETER

Interrogating through an interpreter is time consuming because the interpreter must repeat everything said by the interrogator and source. The interrogator must brief the interpreter before the interrogation can begin. An interrogation with an interpreter will go through all five phases of the interrogation process. After the interrogation is over, the interrogator will evaluate the interpreter.

INTERPRETATION METHODS

During the planning and preparation phase, the interrogator selects a method of interpretation. There are two methods: Simultaneous and alternate. The interrogator obtains information about his interpreter from the senior interrogator. He analyzes this information and talks to the interpreter before deciding which method to use.

- Each item of information not obtained as a direct result of the source's personal experiences must be accompanied by a description of how he obtained that information.
- All dispositions, towns, and other specific geographic locations must be accompanied by a correct, complete set of at least 6-digit universal transverse mercator (UTM) coordinates, to include the correct 100,000-meter grid zone identifier. The UTM coordinates are in STP 34-97E24-SM-TG.
- The information is reported exactly as it was obtained from the source. No information is deleted or added without explanatory comments.
- The report contains no errors in spelling, punctuation, or grammar that affect the meaning of the information reported.

Each report must include the interrogator's assessment of the source's value. This assessment addresses the source's intelligence, experience, cooperation, and reliability. Any areas of special knowledge possessed by the source should be identified.

The assessment codes are established by STANAG 2033. The codes assigned, and a written statement supporting these assignments, must be included on each report.

With the alternate method, the interpreter listens to an entire phrase, sentence, or paragraph. He then translates during natural pauses in the interrogation.

The simultaneous method should be selected only if all the following criteria are met:

- The sentence structure of the target language is parallel to English.
- The interpreter can understand and speak English as well as the target language with ease.
- The interpreter has special vocabulary skills for the topics to be covered.
- The interpreter can easily imitate the interrogator's tone of voice and attitude for the approaches selected.

FM 34-52

- Neither interrogator nor interpreter tends to get confused when using the simultaneous method of interpretation.

With the simultaneous method, the interpreter listens and translates at the same time as the person for whom he is interpreting, usually just a phrase or a few words behind.

If any of the criteria in the simultaneous method cannot be met, the interrogator must use the alternate method. The alternate method should also be used when a high degree of precision is required.

INTERPRETER BRIEFING

Once the interrogator has chosen a method of interpretation, he must brief his interpreter. This briefing must cover—

- Current tactical situation.
- Background information obtained on the source.
- Specific interrogation objectives.
- Method of interpretation to be used.
- The conduct of the interrogation: For example—

—Statements made by the interpreter and source should be interpreted in the first person, using the same content, tone of voice, inflection, and intent. The interpreter must not inject his own personality, ideas, or questions into the interrogation.

—The interpreter should inform the interrogator if there are any inconsistencies in the language used by the source. The interrogator will use this information in his assessment of the source. One example is a source who claims to be an officer, but uses excessive slang and profanity.

- Selected approach techniques and how they are to be applied.
- Physical arrangements of the interrogation site. Ideally, the interrogator and the source should face each other with the interpreter behind the source. This enhances interrogator control by allowing him to simultaneously observe the source and interpreter.
- Need for the interpreter to assist with preparing reports.

Throughout the briefing, the interrogator fully and clearly answers questions the interpreter may have. This helps ensure the interpreter completely understands his role in the interrogation.

CONDUCT THE INTERROGATION

During the interrogation, the interrogator corrects the interpreter if he violates any standards on which he was briefed. For example, if the interpreter injects his own ideas into the interrogation, he must be corrected.

Corrections should be made in a low-key manner. At no time should the interrogator rebuke his interpreter sternly or loudly while they are with the source. The interrogator should never argue with the interpreter in the presence of the source. If a major correction must be made, the interrogator and interpreter should leave the interrogation site temporarily, and only when necessary.

When initial source contact is made, the interpreter must instruct him to maintain eye contact with the interrogator. Since rapport and control must be established, the interpreter should be able to closely imitate the attitude, behavior, and tone of voice used by the interrogator and source. The questioning phase is conducted in the same way it would be if no interpreter were used.

During the termination phase, too, the interpreter's ability to closely imitate the interrogator and source is important. The approaches used are reinforced, and necessary sincerity and conviction must be conveyed to the source.

The interpreter assists the interrogator in preparing reports. He may be able to fill in gaps and unclear areas in the interrogator's notes. He may also assist in transliterating, translating, and explaining foreign terms.

After submitting all reports, the interrogator evaluates the performance of his interpreter. The evaluation must cover the same points of information the interrogator received from the senior interrogator.

The interrogator submits the results of his evaluation to the senior interrogator, who uses this evaluation to update information about the interpreter. This evaluation may also be used to develop training programs for interpreters.

STRATEGIC INTERROGATIONS AND DEBRIEFINGS

Strategic debriefing is questioning of individuals who are sources of information in a strategic or operational environment. This is done to obtain usable information in response to command and national level intelligence needs. Strategic intelligence—

- Provides support to national level planners and operational commanders across the operational continuum, and is useful for long-range planning.
- Is collected in peacetime as well as wartime; it often fills intelligence gaps on extremely sensitive topics or areas.

The objective of the strategic debriefing process is to obtain information of the highest degree of credibility to satisfy outstanding information objectives (IO). This avoids surprises of a strategic nature and consequences.

The types of sources encountered in strategic debriefing are emigres, refugees, resettlers, defectors, and selected US personnel. While there are other types, these represent the majority. Strategic debriefing guidance is provided in DIAM 58-13 and FM 34-5(S), Chapter 4.

DUTIES AND RESPONSIBILITIES OF DEBRIEFERS

Specific duties and responsibilities peculiar to a particular operation will be detailed in unit SOPs. This is due to the diverse nature of the various operations using debriefers outside continental United States (OCONUS) and within the continental United States (CONUS). However, debriefers have the following common duties and responsibilities regardless of assignment.

Notification

Proper response to notification of the availability of a source will depend upon unit operations. The debriefer may have to respond spontaneously as in the case of walk-in sources. He may have the luxury of advance notice as in the case of an invitational interview.

Planning the Debriefing

The process for planning a strategic debriefing is similar to conducting a tactical interrogation, with the following considerations peculiar to the strategic environment. The debriefer should—

- Determine source's area of knowledgeability, personality traits, and potential intelligence value.

- Review IOs.
- Assemble and organize necessary maps, technical reference manuals, city plans, photographs, and handbooks in anticipated debriefing sequence.
- Select an appropriate debriefing site with consideration to host country legal agreements or particular unit SOP directives.

Initial Contact

The debriefer will usually use a friendly rapport posture with sources, who have a status far different from EPWs or detainees.

Questioning

Good questioning techniques, rapport, and effective lead follow-up ensure answering specific IO.

Reporting Information Obtained

Comprehensive and logical note taking is translated into objective reporting within the parameters of intelligence report procedures in DIAM 58-13.

Concluding the Debriefing

An interview is concluded in a manner which enables any debriefer to contact a source at a later date and resume the debriefing process. The debriefer ensures the source receives all promised incentives. It is often necessary to provide source transportation and lodging. Such considerations demand the debriefer be familiar with procedures for using Intelligence Contingency Funds (ICFs).

Operational Security

There is an obvious need for OPSEC before, during, and after any debriefing. Source confidentiality and handling of classified materials demand constant and special attention.

Language Ability

Maintaining a language proficiency is a basic requirement; improvement of dialects, slang, technical terminology, and military vocabulary is a must.

Liaison

A debriefer may have the added responsibility of maintaining local liaison with host-government agencies while OCONUS. Unit SOPs usually dictate necessary and proper procedures.

FM 34-52

S&T Enhancement

The debriefer keeps abreast with target country S&T developments. Intelligence agencies publish numerous reports and summaries which are readily available to the strategic debriefer.

STRATEGIC INTELLIGENCE COMPONENTS

Information gathered as strategic intelligence may be categorized into eight components. An easy way to remember these components is the acronym "BEST MAPS":

- Biographic intelligence.
- Economic intelligence.
- Sociological intelligence.
- Transportation and telecommunications intelligence.
- Military geographic intelligence.
- Armed forces intelligence.
- Political intelligence.
- S&T intelligence.

Each of these components can be divided into sub-components. These components and sub-components are not all-encompassing nor mutually exclusive. This approach enhances familiarization with the types of information included in strategic intelligence.

Biographic Intelligence

Biographic intelligence is the study of individuals of actual or potential importance through knowledge of their personalities and backgrounds. This component can be divided into sub-components:

- Educational and occupational history—civilian and military backgrounds of individuals.
- Individual accomplishment—notable accomplishments of an individual's professional or private life.
- Idiosyncrasies and habits—mannerisms and unusual life styles.
- Position, influence, and potential—present future positions of power or influence.
- Attitudes and hobbies—significant interests that may affect an individual's accessibility.

Biographic information is reported by a message intelligence report in accordance with the format in DIAM 58-13.

Economic Intelligence

Economic intelligence studies economic strength and weaknesses of a country. Its sub-components are—

- Economic warfare—information on the diplomatic or financial steps a country may take to induce neutral countries to cease trading with its enemies.
- Economic vulnerabilities—the degree to which a country's military would be hampered by the loss of materials or facilities.
- Manufacturing—information on processes, facilities, logistics, and raw materials.
- Source of economic capability—any means a country has to sustain its economy.

Sociological Intelligence

Sociological intelligence deals with people, customs, behaviors, and institutions. The sub-components are—

- Population—rates of increase, decrease, or migrations.
- Social characteristics—customs, morals, and values.
- Manpower—divisions and distribution within the workforce.
- Welfare—health and education.
- Public information—information services within the country.

Transportation and Telecommunications Intelligence

Transportation and telecommunications intelligence studies systems dedicated to and used during military emergencies and peacetime. The sub-components are too varied and numerous to cover.

Military Geographic Intelligence

Military geographic intelligence studies all geographic factors (physical and cultural) which may impact on military operations. Physical geography is concerned with natural or manmade geophysical features. Cultural geography provides demographics information.

3-32

Armed Forces Intelligence

Armed forces intelligence is the integrated study of the ground, sea, and air forces of the country. This is often referred to as OB. It is concerned with—

- Strategy—military alternatives in terms of position, terrain, economics, and politics.
- Tactics—military deployments and operations doctrine.
- OB—location, organization, weapons, strengths.
- Equipment—analysis of all military materiel.
- Logistics—procurement, storage, and distribution.
- Training—as carried out at all echelons to support doctrine.
- Organization—detailed analysis of command structures.
- Manpower—available resources and their conditioning.

Political Intelligence

Political intelligence studies all political aspects which may affect military operations. Its subcomponents are—

- Government structure—organization of departments and ministries.
- National policies—government actions and decisions.
- Political dynamics—government views and reactions to events.
- Propaganda—information and disinformation programs.
- Policy and intelligence services—organization and functions.

- Subversion—subversive acts sponsored by the government.

S&T Intelligence

S&T intelligence studies the country's potential and capability to support objectives through development of new processes, equipment, and weapons systems. The subcomponents are—

- Weapons and weapon systems.
- Missile and space programs.
- Nuclear energy and weapons technology.
- NBC developments.
- Basic applied science.
- Research and development systems.

STRATEGIC INTELLIGENCE CYCLE

Equally important to strategic intelligence components is awareness of the strategic intelligence cycle, and the debriefer's role within that 5-step cycle.

The debriefers—

- Identify intelligence gaps.
- Translate these gaps into IO.
- Answer those IO.
- Prepare intelligence reports.
- Prepare intelligence evaluation by the IO originator.

These evaluations measure information and report writing quality (see Appendix E). Evaluations provide vital feedback and guidance to strategic debriefers.

Appendix F contains information on the command language program (CLP) and Appendix G, on individual and collective training.

CHAPTER 4

PROCESSING AND EXPLOITING CAPTURED ENEMY DOCUMENTS

STANAG 2084 defines a document as any piece of recorded information, regardless of form, obtained from the enemy, which subsequently comes into the hands of a friendly force. CEDs can be US or allied documents that were once in the hands of the enemy. CEDs are—

- Typed, handwritten, printed, painted, engraved, or drawn materials.
- Sound or voice recordings.
- Imagery such as videotapes, movies, or photographs.
- Computer storage media including, but not limited to, floppy disks.
- Reproductions of any of the items listed above.

CEDs are mainly acquired two ways: Some are taken from sources; most, however, are captured on the battlefield from former enemy locations and enemy dead.

Documents found on EPWs or detainees or on the battlefield—which can be exploited more efficiently when combined with interrogation—are forwarded with the EPW or detainee to the next echelon in the evacuation channel.

In exceptional cases, documents may be evacuated ahead of the EPW or detainee for advance study by intelligence agencies. A notation should be made on the prisoner's captive tag (Figure 3-6), or accompanying administrative papers, about the existence of such documents and their location if they become separated from the EPW or detainee.

EPW or detainee interrogation has its disadvantages. The main disadvantage is prisoner-derived information usually has to be confirmed from other sources; for example, OB, CEDs, and other EPWs or detainees.

A prisoner may lie to further his army's cause or to ingratiate himself with the interrogator, by telling him what the prisoner believes he wants to hear. A prisoner may lack the background knowledge needed to interpret what he has seen or to pass it on accurately. He may misunderstand or misinterpret the interrogator's question because of language barriers or fright.

An EPW or detainee may have been misinformed or misled concerning the true situation for any number of

reasons. This does not mean EPW or detainee interrogation is fruitless; however, it should not be considered absolutely reliable.

In contrast, a CED is something which the enemy has written for its own use. For this reason, CEDs are usually truthful and accurate. Spectacular cases have occurred in which falsified documents have been permitted to fall into enemy hands as a means of deception. However, these cases are exceptions and thus are usually famous. Because deceptive documents are unusual, a commander tends to believe in the authenticity of captured documents.

Information contained in CEDs can prove to be of intelligence value to commanders at all levels. CEDs are important because they provide information directly from the enemy. Only rarely will a single document or group of documents provide vital information. Usually, each document provides a small bit of a larger body of information. Each CED, much like a single piece of a puzzle, contributes to the whole.

In addition to their tactical intelligence value, technical data and political indicators can be extracted from CEDs that are important to strategic and national level agencies. CEDs can be helpful in exploiting sources.

The handling methods and reporting procedures to be used by US personnel acquiring CEDs are contained in STANAG 2084. It states CEDs, except those belonging to captured enemy equipment (CEE), will be forwarded for exploitation to the appropriate captured DOCEX center (normally organic to major North Atlantic Treaty Organization [NATO] commands). There are three types of documents:

- Official—documents of governmental or military origin (such as overlays, field orders, maps, codes, field manuals, and reports).
- Identity—personal items (such as cards or books, passport, and drivers license).
- Personal—documents of a private or commercial origin (such as letters, diaries, and photographs).

The volume of CEDs in combat will overwhelm an interrogation element of the size projected for a heavy division. A flow of CEDs similar to those encountered

FM 34-52

in OPERATIONS URGENT FURY, JUST CAUSE, and DESERT STORM would supply enough targets to keep a light division's interrogators busy around-the-clock screening and categorizing CEDs. Any attempt to conduct deeper exploitation would result in a tremendous evacuation delay and the end of timely reporting.

Experience shows a division involved in a HIC may have to process between 525 and 5,300 sources per week. While these figures are estimates, they demonstrate the inability of a division's own interrogators to simultaneously exploit sources and CEDs.

Divisions may receive additional interrogation assets from corps, depending on their mission. Prior planning must be conducted to establish the availability of these assets and their deployment within the division.

The density of interrogation assets and command emphasis on the collection effort determine mission requirements. The feasibility of a dual collection mission may also be the result of initial IPB by the commander's intelligence staff. If an echelon cannot conduct a dual collection effort, EPW interrogation receives priority.

CEDs, while not affected by memory loss, are often time sensitive; therefore, they are quickly screened for possible exploitation. Interrogators are given the CED exploitation mission because of their linguistic ability. This makes printed and typed material readily exploitable, but many handwritten documents are illegible.

DOCUMENT CATEGORIES

The category assigned to each CED must be recorded as part of the Captured Document Log entry for that CED. Interrogators should also enter a brief description of that CED. This description should identify the type of document (such as sound recording, written material, painting, engraving, imagery); and what language was used in the CED.

This entry should also specify the physical construction of the CED (such as typed, printed, handwritten, tape cassette, photographs, film) and give some indication of its size (such as the number of pages, rolls of film, cassettes). The categories are discussed below.

CATEGORY A

Category A documents—

- Contain spot reportable information.
- Are time sensitive.

Information contained in undeveloped imagery and recordings is inaccessible to most interrogation elements. The intelligence value of painted, drawn, or engraved material cannot be exploited by many elements unless it is accomplished by explanatory information in writing. An example of this would be an overlay prepared without map data, registration points, or identifying terrain features.

In spite of these limitations, an estimated 90 percent of all the information contained in CEDs can be exploited.

Figure 4-1 shows a comparison along a timeline of the amounts of information available to the interrogator from the two collection targets.

The comparison assumes the CEDs and sources initially had the same amount of information, and it was of equal intelligence value. The figures used are conservative estimates, and the time between the two target types might be even greater between 24 and 72 hours.

The percentage of information available from sources drops sharply during the first 24 hours after capture. This represents the rapid loss of what sources would consider to be insignificant details. A slower drop in the percentage begins at 48 hours to represent the resurgence of established value systems. This resurgence makes it harder for interrogators to obtain what information the source still remembers.

- Contain significant intelligence information.
- May be critical to successfully accomplishing friendly COAs.

Significant intelligence topics include enemy OB, new weapons or equipment on the battlefield, and may contain information that indicates a significant change in the enemy's capabilities or intentions.

When a document is identified as Category A, the document examiner immediately ceases screening operations and submits a spot report in SALUTE format of the critical information from the document. The examiner then resumes screening operations.

CATEGORY B

Category B documents contain information pertaining to enemy cryptographic or communication systems. Once a document is identified as Category B, it is clas-

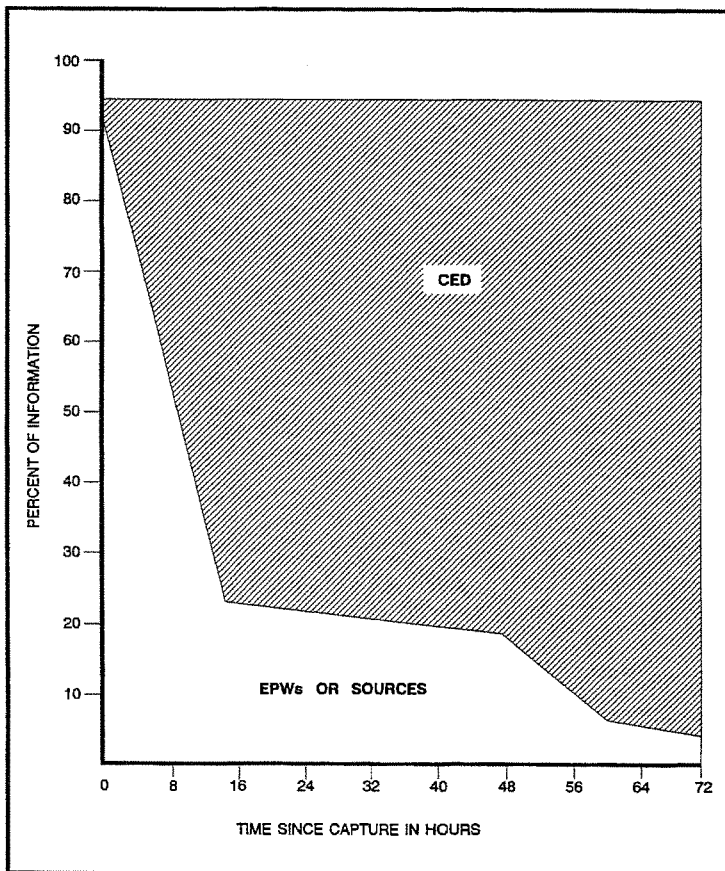

Figure 4-1. Comparison timelines.

FM 34-52

sified SECRET. This is done to limit the number of people having knowledge of the capture or contents.

Category B documents may contain spot reportable information, thereby requiring immediate exploitation. In every case, these documents will be transferred through secure channels to the technical control and analysis element (TCAE) or TSA as soon as possible.

CATEGORY C

Category C documents contain no spot reportable or time-sensitive information, but do contain information of general intelligence value that does not indicate significant changes in enemy capabilities or intentions.

DOCUMENT HANDLING

The accountability phase begins at the time the document is captured. Original documents must not be marked, altered, or defaced in any way. Documents must be clearly tagged. The capturing unit attaches a captured document tag (DA Form 5976, Part C) to each document; multiple CEDs are bundled or bagged together. The capture data is always recorded on a captured document tag. Figure 4-2 shows a format to use when a capture tag is not available; record the required data on any paper.

The captured document tag should be assigned a sequential number at the first formal exploitation point, showing the nationality of the capturing force by national letters prescribed in STANAG 1059. The capturing unit will record the information as follows:

- Time document was captured, recorded as a DTG.

Category C documents may be of interest or value to other agencies. When identified as Category C, they require exploitation, regardless of content.

CATEGORY D

Category D documents appear to contain information of no intelligence value. Documents are not identified as Category D until after a thorough examination by document translation specialists at the highest command interested. This is accomplished at EAC. Category D documents are to be disposed of as directed by the appropriate authority.

- Place document was captured, including the six- or eight-digit coordinate, and description of the location of capture.
- Identity of the capturing unit.
- Identity of the source from whom the document was taken, if applicable.
- Summary of the circumstances under which the document was found.

EVACUATION

CED intelligence value will be determined and exploited as early as possible. The document must be forwarded immediately to higher headquarters.

CAPTURED DOCUMENT TAG	
	NATIONALITY OF CAPTURING FORCE (STANAG 1059)
1. DATE/TIME CAPTURED:	<u>091756Z APR 99</u>
2. PLACE CAPTURED:	<u>TA 123456</u>
3. CAPTURING UNIT:	<u>1CO/2/3/4 Regt</u>
4. IDENTITY OF SOURCE (IF APPLICABLE):	_____
5. CIRCUMSTANCES OF CAPTURE:	<u>FOUND IN ABANDONED ENEMY CP.</u>

Figure 4-2. Captured document tag format.

Custody of CEDs transfers (normally from the MP) to MI when MI identifies a document as having intelligence interest. When MI interest in an EPW-related CED stops, MI gives it back to the MP.

Echelon Responsibilities

There is no set time for how long any particular echelon may keep a document for study. The primary aim of speedy evacuation to the rear for interrogator examination remains. During evacuation, escorts carefully guard CEDs to prevent recapture, loss, or destruction.

Capturing Unit Responsibilities

The capturing unit is responsible for properly tagging and securing CEDs found on an EPW or on the battlefield. It forwards CEDs found on the battlefield directly to its S2. Documents found on an EPW stay with him. If the capturing unit takes CEDs from a captured person, it does so in accordance with the GPW and unit SOPs.

The capturing unit must clearly tag CEDs to show which EPW it was taken from so they can be matched up later. Specific responsibilities are discussed below.

Capture Unit's S2. This officer is responsible for tagging all untagged CEDs. The S2 performs battlefield DOCEX as practicable and ensures speedy CED evacuation to brigade.

Escort or Guards, Brigade and Below. The brigade provides escorts and guards to transport EPWs and CEDs from subordinate battalions to the division forward collecting point. The guards—

- Assume accountability for transported CEDs.
- Ensure each item transported has a completed captured document tag attached.
- Ensure items gathered from different battalions are not mixed.

Brigade IPW Team. This 2- to 4-person team's mission, when placed in DS, is to collect information of critical interest to the supported brigade commander. It concentrates whatever DOCEX efforts it can on CEDs found with EPWs. MP evacuate all examined CEDs, along with unexamined CEDs, via EPW evacuation channels.

Division IPW Section. This interrogation section's mission is similar to that of the brigade IPW team. At this stage, priority evacuation of high value EPWs and CEDs direct to EAC is possible. Most EPWs and CEDs

of intelligence interest go to the corps EPW holding facility.

MP Escorts. MP assume responsibility for evacuating CEDs and EPWs from the brigade's capturing units at the division's forward collecting point. They escort EPWs and CEDs through EAC. MI assumes control from the MP when interrogators determine a captured item or EPW is of intelligence value.

Corps CED Team. The CIF commander may task-organize a team of interrogators at the corps EPW holding facility to screen incoming CEDs for examination by the CIF DOCEX element. The CED screening team—

- Sorts incoming CEDs.
- Identifies those of possible intelligence value.
- Separates them.
- Assumes custody from the MP.
- Batches selected CEDs and delivers them to the CIF DOCEX element.

CIF DOCEX Element. At the CIF or combined corps interrogation facility (CCIF), interrogators scan selected CEDs and decide their intelligence category. They assign serial numbers and examine CEDs to answer corps collection requirements, filing spot reports in SALUTE format as necessary.

CIF interrogators batch and forward Category B documents to specialized collection activities. Interrogators label, batch, and direct evacuation of all other documents to EAC via MP and EPW evacuation channels. Examples are the TECHINT team, CI team for espionage items, and Criminal Investigation Division (CID) or SJA for war crimes information.

Theater Document Examiners. Theater level interrogators, normally at a TIF, perform a final examination of all documents of possible theater intelligence value before storing or evacuating them. The Defense Intelligence Agency (DIA) sets procedures for exploitation of documents above theater Army level. The following procedures have been devised to aid timely exploitation:

- Technical documents (TECHDOCs) found with materiel that relate to their design or operation should be evacuated with the materiel. When the materiel cannot be evacuated, the documents should be identified with the materiel by attaching a sheet marked "TECHDOC." This should list the precise location, time, circumstance of capture,

FM 34-52

and a detailed description of the materiel. If possible, photographs should be taken of the equipment and evacuated with the document. An object of known size such as a ruler should be placed close to the materiel and photographed with it to provide a size reference.

- CEDs containing communications or cryptographic information are handled as secret material and are evacuated through secure channels to the TCAE at division and the TSA at EAC.

ACCOUNTABILITY

At each echelon, starting with the capturing unit, steps are taken to ensure CED accountability is maintained during document evacuation. To establish accountability, the responsible element inventories all incoming CEDs. Thorough accountability procedures at each echelon ensure CEDs are not lost. To record each processing step as it occurs helps correct mistakes in CED processing.

Accountability is accomplished by anyone who captures, evacuates, processes, or handles CEDs. All CEDs should have completed captured document tags. An in-

coming batch of documents includes a CED transmittal. Figure 4-3 shows this format. The exact format for a document transmittal is a matter of local SOP, but it should contain the information listed below:

- The identity of the element to which the CEDs are to be evacuated.
- The identity of the unit forwarding the CEDs.
- The identification number of the document transmittal.
- Whether or not CEDs in the package have been screened and the screening category. (If not screened, NA is circled.)
- A list of the document serial numbers of the CEDs in the package.

When a batch is received without a transmittal, the interrogation element contacts the forwarding unit and obtains a list of document serial numbers.

The interrogation element records all trace actions in its journal. Accountability includes—

CAPTURED ENEMY DOCUMENT TRANSMITTAL			
TO: <u>G2, X CORPS</u>	DATE/TIME: <u>04</u>		
FROM: <u>G2, 25 INF DIV</u>	TRANSMITTAL NO: <u>010</u>		
SCREENED: YES NO	CATEGORY: A B <input checked="" type="radio"/> C D NA		
DOCUMENT SERIAL NUMBERS:			
<u>TR-AR-091 thru 100</u>	_____		
<u>SY-AR-8.1 thru 9.7</u>	_____		
_____	_____		
_____	_____		
_____	_____		
_____	_____		

Figure 4-3. Sample CED transmittal.

- Inventorying the CEDs as they arrive.
- Initiating necessary trace actions.
- Maintaining the CED log.

When intelligence derived from a CED is included in a unit or information INTREPs, the identification letters and number of the document concerned are quoted to avoid false confirmation. All CEDs are shipped with any associated documents.

INVENTORY

An inventory of incoming CEDs is conducted initially by comparing the CED to the captured document tag and accompanying transmittal documents. This comparison identifies—

- Transmittals that list missing CEDs.
- Document tags not attached to CEDs.
- CEDs not attached to document tags.
- CEDs not listed on the accompanying transmittal documents.

LOG

The captured document log, shown at Figure 4-4, is a record of what an element knows about a CED. After trace actions are initiated, the CEDs are entered in the remarks section of the captured document log. This log must contain the following:

- Name of capturing unit.
- File number (a sequential number to identify the order of entry).
- DTG the CED was received at this element.
- Document serial number of the captured document tag.
- Identification number of the transmittal document accompanying the CED.
- Full designation of the unit that forwarded the CED.
- Name and rank of individual that received the CED.

DOCUMENT EXPLOITATION

As incoming CEDs are accounted for, the exploitation phase for intelligence information begins. Exploitation includes—

- DTG and place of capture (as listed on the captured document tag).
- Identity of the capturing units (as listed on the captured document tag).
- Document category (after screening).
- Description of the CED (at a minimum the description includes the original language; number of pages; type of document such as a map, letter, or photograph; and the enemy's identification number for the CED, if available).
- Destination and identification number of the outgoing transmittal.
- Remarks (other information that can assist the unit in identifying the CED to include processing codes. These are set up by local SOPs to denote all actions taken with the document while at the element, including spot (SALUTE) reports, translations, reproductions, or return of the CED to the source from whom it was taken).

Accountability for the CED should be established at each echelon once the actions described above have been done.

TRACE ACTIONS

When necessary, the receiving unit initiates a CED trace action. Trace actions are initiated on all missing CEDs, captured document tags, and all information missing from the captured document tag. Trace actions are initiated by contacting elements from which the documents were received. This corrective action can be completed swiftly if that unit's captured document log was filled out completely.

If necessary, the trace action continues to other elements that have handled the document. If a captured document tag is unavailable from elements that have previously handled the CED, the document examiner fills out a captured document tag for the document using whatever information is available. Attempts to obtain missing CEDs are critical because of the information those CEDs might contain.

- CED screening to determine potential intelligence value.
- Extracting pertinent information from the CED.

FM 34-52

UNIT: 16 INF DIV (A)

FILE NUMBER	RECEIVED DTG	DOCUMENT SERIAL NUMBER	INCOMING TRANS. MISSION NUMBER	FORWARDING UNIT	RECEIVED BY	TIME AND PLACE OF CAPTURE (DTG)
0001	111910Z	45-AR-190.1	NA	4 th Ede	Royce	110719Z NC 123456
0002	111917Z	45-AF-WAY6	NA	1st Ede	Jones	111314Z BC 654321
CAPTURING UNIT	SCREENING CATEGORY	DESCRIPTION OF DOCUMENT	OUTGOING TRANSMITTAL	REMARKS		
B/11/3/3	C	PERSONAL LETTER	011.17	NONE		
D/2/3/4	A	OPLAN	019.44	NONE		

Figure 4-4. Captured document log format.

- Reporting the extracted information.

CEDs are processed and exploited as soon as possible within the constraints of the unit's mission. The main mission of some units is to exploit human sources rather than to translate CEDs; therefore, manpower constraints may limit time for translation.

However, translating CEDs is necessary at any echelon where interrogators and translators are assigned. Therefore, it is important that interrogation elements possess qualified personnel to provide the translation support required. Intelligence units ensure there is no delay in CED exploitation.

Qualified personnel or document copying facilities should be available to handle CEDs; personnel should be available to exploit the volume or type of documents concerned. If not, documents are forwarded immediately to the next higher echelon. Copying availability is determined by the echelon in question, as well as mission and mobility considerations.

CED SCREENING

Document exploitation begins when CEDs are screened for information of immediate intelligence interest. As each document is screened, it is assigned one of four category designations. The category assigned determines the document's priority for exploitation and evacuation.

CED screening procedures include receiving the latest PIR, IR, and SIR; current friendly and enemy situation update; relevant OB; and review.

Brigade and division interrogators get this information from the supported J2, G2, or S2. Corps and theater DOCEX elements receive this information from their parent MI battalion or brigade. The DOCEX elements are responsible for obtaining and providing such operational intelligence information to their DOCEX teams.

TRANSLATING

Once a CED has been screened, the document must be exploited. The translation must be clearly and accurately typed or handwritten; this ensures usability. Also, as part of interrogation duties, the interrogator may have previously translated a document by sight to help gain a source's cooperation.

TYPES OF TRANSLATIONS

There are three types of translations:

SPECIAL DOCUMENT HANDLING

TECHDOCs are given special handling to expedite exploitation and evacuation. TECHDOCs are handled as Category A CEDs until screened by TECHINT personnel. Generally, TECHDOCs accompany the captured equipment until the intelligence exploitation is completed. TECHDOCs include maintenance handbooks, operational manuals, and drawings. Examples of TECHDOCs include—

- Air Force documents (AIRDOCs). These are documents of any category captured from crashed enemy aircraft, particularly if related to enemy anti-aircraft defense or air control and reporting systems. AIRDOCs are transmitted to the nearest Air Force headquarters without delay.
- Navy documents (NAVDOCs). These are documents taken from ships (for example, code books, call signs, frequency tables, and identification symbols). NAVDOCs are forwarded without delay to the nearest Navy headquarters.
- Maps and charts of enemy forces. Captured maps and charts containing any operational graphics are evacuated immediately to the supporting all-source analysis center. Captured maps and charts without graphics may be transmitted to the topographical intelligence section attached to corps.

SCREENING AT HIGHER ECHELONS

CEDs can be recategorized during screening conducted at higher echelons. The information may have become outdated, or the echelon currently exploiting the document may have different intelligence requirements.

- Full—one in which the entire document is translated. It is time-intensive and requires manpower, especially for lengthy documents or TECHDOCs. It is unlikely many full translations will be performed at corps or below. Even when dealing with Category A documents, it may not be necessary to translate the entire document to gain the information it contains.

FM 34-52

- **Extract**—one in which only a portion of the document is translated. For instance, a TECHINT analyst may decide a few paragraphs in the middle of a 600-page helicopter maintenance manual merit translation, and a full translation is not necessary. The analyst would request only what he needed.
- **Summary**—one in which a translator begins by reading the entire document. He then summarizes the main points of information instead of rendering a full or extract translation.

A summary translation requires a translator have more analytical abilities. The translator must balance the need for complete exploitation of the document against time available in combat operations.

A summary translation may also be used by translators working in languages in which they have not been formally trained. For instance, a Russian linguist may not be able to accurately deliver a full translation of a Bulgarian language document. However, he can probably render a usable summary of the information it contains.

TRANSLATION REPORTS

Except for SALUTE spot reports, all information resulting from document exploitation activities will be reported in a translation report. After all required SALUTE reports have been submitted, the translator will prepare required translation reports.

CEDs that contain information of intelligence value that was not SALUTE reported are the subject of translation reports. Translation reports are prepared on all Category C CEDs and include portions of Category A, TECHDOCs, and Category B CEDs not SALUTE reported.

The priorities for preparing translation reports are—

- Category A.
- TECHDOCs.
- Category B.
- Category C.

A translation report, shown at Figure 4-5, should contain the following information:

- Destination, which is the element to which the report will be forwarded.

- Originator, which is the element that prepared the report.
- Date of preparation showing the DTG.
- Report number as designated by local SOP.
- Document number taken from the captured document tag.
- Document description including type of document, number of pages, physical construction of document, and enemy identification number, if applicable.
- Original CED language.
- DTG document was received at element preparing the report.
- DTG document was captured.
- Place document was captured.
- Identity of capturing unit.
- Circumstances under which document was captured.
- Rank and last name of translator.
- Type of translation: full, extract, or summary.
- Remarks for clarification or explanation, including the identification of the portions of the document translated in an extract translation.
- Classification and downgrading instructions, according to AR 380-5.

DISSEMINATION AND RECORDS

The translator records each exploitation step taken in the captured document log. Transmission of spot and translation reports is entered in the element's journal.

At least two copies are prepared for each spot (SALUTE) and translation report. One copy is placed in the interrogation elements's files. The other accompanies the CED when it is evacuated. When the CED cannot be fully exploited, a copy of the CED should be made and retained. The original CED is forwarded through evacuation channels. Even when copies of an unexploited CED cannot be made, the original CED is still forwarded through evacuation channels without delay.

(CLASSIFICATION)	
TRANSLATION REPORT	
TO: G2, 23d Inf Div (MECH)	DATE: 291130ZAUG99
FROM: IPW Sec, I&S Co, 231st MI Bn	REPORT NUMBER: 08-0356
PART I. CONTROL DATA:	
1. DOCUMENT NUMBER: US-WAIBVO-03093.	
2. DOCUMENT DESCRIPTION: Personal letter, 1 page, handwritten.	
3. DOCUMENT'S ORIGINAL LANGUAGE: Russian.	
4. DATE AND TIME RECEIVED: 290510ZAUG99.	
5. DATE AND TIME OF CAPTURE: 290120ZAUG99.	
6. PLACE OF CAPTURE: vic NB146122.	
7. CAPTURING UNIT: Co. A, 2d Bn, 1st Inf Bde, 23d Inf Div.	
8. CIRCUMSTANCES OF CAPTURE: During ambush.	
9. TRANSLATOR: SGT Royce.	
10. TRANSLATION TYPE: Full.	
PART II. TRANSLATION TEXT:	
My dear Serezhen'ka:	
It has been a long time since I received a letter from you. How are you and where are you? The last time you wrote that fighting was going on around you all the time, and this worries me a lot. Take care of yourself. There have been many changes at home. Your mother, despite her age, had to go to work in the factory. They make tanks there, but the sign over the entrance says this is a sugar plant. I don't know why they do this. At the school where I work, we were also told to go and work at the same plant. They are going to close the school. Everyone has to go to the front or work in the war industry. I would be more at ease if I knew you are alive and well. Please write as soon as you can.	
Your KATHY.	
PART III: REMARKS: None.	
(CLASSIFICATION)	

Figure 4-5. Sample translation report.

FM 34-52

EVACUATION PROCEDURES

For friendly forces to benefit fully from a document, send CEDs to the element most qualified to exploit them as quickly as possible. Information gained from a CED is frequently time-sensitive. If a document is not sent to the element most capable of exploiting it, time will be lost. Time lost in exploiting the document may reduce or even negate the value of the information. The CED evacuation procedures in use at any element must ensure documents are shipped to their proper destinations in a timely manner.

NORMAL EVACUATION

CEDs are normally evacuated from echelon to echelon through the intelligence organizational chain. Depending on the type of documents, they may eventually be evacuated to the National Center for Document Exploitation. Interrogators and translators can exploit CEDs at every echelon; they will make an attempt to exploit CEDs within their expertise and technical support constraints.

DIRECT EVACUATION

Some CEDs are evacuated to different elements based upon the information contained and the type of document concerned. Direct evacuation to an element outside the chain of command takes place at the lowest practical echelon. Specific evacuation guidelines contained in local unit SOPs are followed when dealing with documents requiring special handling.

EVACUATION PRIORITIES

When transportation assets are limited, CEDs are evacuated according to priority. The priority is the category assigned to the CED. All Category A CEDs will be evacuated first, TECHDOCs will be considered Category A CEDs until examined by the captured materiel exploitation center (CMEC), followed in order by Categories B, C, and D.

Category B documents are evacuated to the TCAE, which maintains a SIGINT and EW data base. Category B documents pertaining to communications equipment are duplicated, if possible; the duplicate documents are sent to the CMEC.

CEDs not evacuated are held until the next transportation arrives. These remaining CEDs are combined with any other CEDs of the same category that have arrived and have been processed.

When determining evacuation priorities, interrogators consider CEDs ready for evacuation. Lower priority CEDs, no matter how old, are never evacuated ahead of those with higher priority. A package of documents contains CEDs of only one category. All un-screened CEDs are handled as Category C documents, but they are not packaged with screened Category C documents. CEDs in a single package must have the same destination.

TRANSMITTAL DOCUMENTS

When CEDs are evacuated from any echelon, a document transmittal is used (see Figure 4-3). A separate document transmittal is prepared for each group of CEDs to be evacuated.

When second copies of Category B CEDs are being sent to a TECHINT element, a separate document transmittal is required.

The transmittal identification number is recorded in the captured document log as part of the entry for each CED.

All CEDs being evacuated must be accompanied with the appropriate—

- TECHDOC cover sheet.
- SECRET cover sheet on Category B documents.
- Translation reports and hard-copy spot reports in SALUTE format accompanying translated documents.
- Captured document tags.

ASSOCIATED DOCUMENTS

Preparations for further CED evacuation begin with verifying document serial numbers. This is done by comparing the entry in the captured document log with the entry on the captured document tag attached to each CED.

Once all CEDs are present, copies of all reports derived from the CEDs are assembled. A copy of all SALUTE and translation reports is placed with the CEDs that were the sources of those reports. When possible, all Category B CEDs and their captured document tags should be copied.

GROUP DOCUMENTS

CEDs are first grouped according to their assigned screening category. Personnel must be careful when sorting CEDs to ensure no CED is separated from its associated documents. These large groupings can be broken down into smaller groups. Each of these smaller groupings consists of CEDs that were—

- Captured by the same unit.
- Captured in the same place.
- Captured on the same day at the same time.
- Received at the interrogation element at the same time.

DOCUMENTS CAPTURED WITH A SOURCE

The documents captured with a source play an important role in the interrogation process and can contain reportable information the same as with a CED obtained on the battlefield. During source screening operations, for instance, documents can indicate a specific source may have information pertaining to the commander's intelligence requirements.

The interrogator uses various pieces of information in forming his interrogation plan. Documents captured with the source may provide the key to the approach necessary to gain the source's cooperation.

Guidelines for the disposition of the source's documents and valuables are set by international agreement and discussed in more detail in AR 190-8 and FM 19-4.

One way the source's trust and continued cooperation can be gained is through fair and equitable handling of his personal possessions. In some instances, such treatment can make it more likely the source will cooperate during interrogation. Furthermore, fair treatment by the interrogator and holding area personnel can ease tensions in the confinement facility.

DOCUMENT DISPOSAL

The disposition of documents captured with a source is normally an MP function. Because of their language capabilities, interrogators at the compound probably will be required to provide assistance.

The MP sign for all documents taken from sources. To ensure proper handling and expeditious disposition of these documents, the interrogation element should sign for any documents captured with a source. When the interrogation element assumes control of docu-

ments, they process them according to established procedures.

When documents are captured with a source, it is recommended that they be taken away from him so he cannot destroy them. However, under no circumstances is a source's identification card to be permanently taken from him.

When documents are taken from a source, it is necessary to ensure the source from whom they were taken can be identified. The best way to do this is with the source's captive tag. The bottom portion of the tag is designed to be used for marking equipment or documents. Three possible actions may be taken with documents captured with a source. The documents may be confiscated, impounded, or returned to the source.

Confiscation

Documents confiscated from a source are taken away with no intention of returning them. Official documents, except identification documents, are confiscated and appropriately evacuated. The intelligence value of the document should be weighed against the document's support in the interrogation of the source.

Category A documents require exploitation and should be copied. One copy should be translated and exploited separately, and the other copy should be evacuated with the source. If copying facilities are not available, a decision should be made on whether to evacuate the document with the source or separately.

Category B CEDs should be evacuated to the TCAE for appropriate exploitation. Category C official documents can best be used in the interrogation of the source. Therefore, these CEDs and Category D official documents should be evacuated with the source.

Impounded

Impounded CEDs are taken away with the intention of returning them later. When a document is impounded, the source must be given a receipt. The receipt must contain a list of the items impounded and the legible name, rank, and unit of the person issuing the receipt. All personal effects, including monies and other valuables, will be safeguarded.

An inventory of personal effects that have been impounded will be entered on DA Form 4237-R (see Figure 3-1). Also, the officer in charge or authorized representative will complete and sign DA Form 1132-R (Prisoner's Personal Property List - Personal). A copy

FM 34-52

will be provided the source. See AR 190-8 for procedures on handling personal effects.

Returned

Returned CEDs are usually personal in nature, taken only for inspection and information of interest, and immediately given back to the source. Personal documents belonging to a source will be returned to the source after examination in accordance with the GPW. Copies of such papers may be made and forwarded if considered appropriate. An identification document must be returned to the source.

RECOGNITION AND EVACUATION OF DOCUMENTS

In a fast-moving tactical situation, it is possible documents captured with sources will not be handled expeditiously. Final disposition of these documents may not be made until the source is evacuated at least as far as the corps holding area.

Some documents captured with a source will aid in the interrogation of the source. Others, particularly Category A, should be copied and evacuated separately.

One copy can remain with the source to aid in the interrogation, and the other can be translated and exploited separately.

It is essential that the capturing unit correctly identify the documents captured with the source. This is more easily done when the interrogation element, rather than the MP element, signs for the documents captured with sources.

EVACUATION OF SIGNIFICANT DOCUMENTS

To efficiently exploit CEDs and sources, documents captured with a source are normally evacuated with the source. A document of great significance may be evacuated ahead of the source, but a reproduction should be kept with the source. If reproduction is not possible, note on the captured document tag where the document was sent.

Significant documents such as Categories A and B, TECHDOCs, maps, charts, AIRDOCs, and NAVDOCs are evacuated directly.

APPENDIX A
UNIFORM CODE OF MILITARY JUSTICE EXTRACT

Article 78, Accessory after the fact

Text of the offense: Any person subject to this chapter who, knowing that an offense punishable by this chapter has been committed, receives, comforts, or assists the offender in order to hinder or prevent his apprehension, trial, or punishment shall be punished as a court-martial shall direct.

Article 80, Attempts

Text of the offense:

(a) An act, done with specific intent to commit an offense under this chapter, amounting to more than mere preparation and tending, even though failing, to effect its commission, is an attempt to commit that offense.

(b) Any person subject to this chapter who attempts to commit any offense punishable by this chapter shall be punished as a court-martial may direct, unless otherwise specifically prescribed.

(c) Any person subject to this chapter may be convicted of an attempt to commit an offense although it appears on the trial that the offense was consummated.

Article 81, Conspiracy

Text of the offense: Any person subject to this chapter who conspires with any other person to commit an offense under this chapter shall, if one or more of the conspirators does an act to effect the object of the conspiracy, be punished as a court-martial may direct.

Article 93, Cruelty and maltreatment

Elements of the offense:

(1) That a certain person was subject to the orders of the accused; and

(2) That the accused was cruel toward, or oppressed, or maltreated that person. (The cruelty, oppression, or maltreatment, although not necessarily physical, must be measured by an objective standard.)

Article 118, Murder

Text of the offense: Any person subject to this chapter who, without justification or excuse, unlawfully kills a human being, when he—

(1) has a premeditated design to kill;

(2) intends to kill or inflict great bodily harm;

(3) is engaged in an act that is inherently dangerous to others and evinces a wanton disregard of human life; or

(4) is engaged in the perpetration or attempted perpetration of a burglary, sodomy, rape, robbery, or aggravated arson;

is guilty of murder, and shall suffer punishment as a court-martial shall direct, except that if found guilty under clause (1) or (4), he shall suffer death or imprisonment for life as a court-martial may direct.

Article 119, Manslaughter

Text of the offense:

(a) Any person subject to this chapter who, with an intent to inflict great bodily harm, unlawfully kills a human being in the heat of sudden passion caused by adequate provocation is guilty of voluntary manslaughter and shall be punished as a court-martial may direct.

(b) Any person subject to this chapter who, without an intent to kill or inflict great bodily harm, unlawfully kills a human being—

(1) by culpable negligence; or

(2) while perpetrating or attempting to perpetrate an offense, other than those named in clause (4) of Article 118, directly affecting the person; is guilty of involuntary manslaughter and shall be punished as a court-martial may direct.

Article 124, Maiming

Text of the offense: Any person subject to this chapter who, with intent to injure, disfigure, or disable, inflicts upon the person of another an injury which—

(1) seriously disfigures his person by any mutilation thereof;

(2) destroys or disables any member or organ of his body; or

(3) seriously diminishes the physical vigor by the injury of any member or organ;

FM 34-52

is guilty of maiming and shall be punished as a court-martial may direct.

Article 127, Extortion

Text of the offense: Any person subject to this chapter who communicates threats to another person with the intention thereby to obtain anything of value or any acquittance, or immunity is guilty of extortion and shall be punished as a court-martial may direct.

Article 128, Assault

Text of the offense:

(a) Any person subject to this chapter who attempts or offers with unlawful force or violence to do bodily harm to another person, whether or not the attempt or offer is consummated, is guilty of assault and shall be punished as a court-martial may direct.

(b) Any person subject to this chapter who—

(1) commits an assault with a dangerous weapon or other means or force likely to produce death or grievous bodily harm; or

(2) commits an assault and intentionally inflicts grievous bodily harm with or without a weapon;

is guilty of aggravated assault and shall be punished as a court-martial may direct.

Article 134, Homicide, negligent

Elements of the offense:

(1) That a certain person is dead;

(2) That this death resulted from the act or failure to act of the accused;

(3) That the killing by the accused was unlawful;

(4) That the act or failure to act of the accused which caused the death amounted to simple negligence; and

(5) That, under the circumstances, the conduct of the accused was to the prejudice of good order and discipline in the armed forces or was of a nature to bring discredit upon the armed forces.

Article 134, Misprision of a serious offense

Elements of the offense:

(1) That a certain serious offense was committed by a certain person;

(2) That the accused knew that the said person had committed the serious offense;

(3) That thereafter, the accused concealed the serious offense and failed to make it known to civilian or military authorities as soon as possible;

(4) That the concealing was wrongful; and

(5) That, under the circumstances, the conduct of the accused was to the prejudice of good order and discipline in the armed forces or was of a nature to bring discredit upon the armed forces.

Article 134, Soliciting another to commit an offense

Elements of the offense:

(1) That the accused solicited a certain person or persons to commit a certain offense under the code other than one of the four offenses named in Article 82;

(2) That the accused did so with the intent that the offense actually be committed; and

(3) That, under the circumstances, the conduct of the accused was to the prejudice of good order and discipline in the armed forces or was of a nature to bring discredit upon the armed forces.

Article 134, Threat, communicating

Elements of the offense:

(1) That the accused communicated certain language expressing a present determination or intent to wrongfully injure the person, property, or reputation of another person, presently or in the future;

(2) That the communication was made known to that person or a third person;

(3) That the communication was wrongful; and

(4) That, under the circumstances, the conduct of the accused was to the prejudice of good order and discipline in the armed forces or was of a nature to bring discredit upon the armed forces.

APPENDIX B

QUESTIONING GUIDES

This appendix contains sample tactical questions and topics for specific EPWs and detainees. It also contains a sample overall objective statement for an interroga-

tion element and a sample overall objective statement with IEW tasks.

RIFLEMEN

Depending on assignment and experience, riflemen can be expected to have tactical information concerning mission, organization, and locations of enemy infantry units. Topics for interrogation include—

- Identification of source's squad, platoon, company, battalion, regiment, and division.
- Organization, strength, weapons, and disposition of squad, platoon, and company.
- Number of newly assigned personnel in unit within last 30 days.
- Location and strength of men and weapons at strongholds, outposts, and observation posts in source's immediate area.
- Source mission immediately before capture as well as mission of source's squad, platoon, company, and higher echelons.
- Location and description of defensive installations, such as missile sites, antitank ditches, and emplacements, minefields, roadblocks, and barbed wire entanglements in source's area before capture. Description of weapons in which these locations are covered.
- Names and personality information of small unit commanders known to source.

- Possible identifications of support mortar, artillery, and armored units.
- Status of food, ammunition, and other supplies.
- Troop morale.
- Casualties.
- Defensive and protective items of NBC equipment; status of NBC training and defensive NBC instructions, and offensive capability of NBC operations.
- Status of immunizations; new shots, booster shots more frequently than normal.
- Stress on care and maintenance of NBC protective equipment.
- Issuance of new or different NBC protective equipment.
- Morale and esprit de corps of civilians.
- Civilian supply.
- Health of civilians, and medicine availability.
- Night maneuvers, rehearsals, unit size, night vision devices, and special equipment.

MESSENGERS

Messengers are frequently chosen on the basis of above-average intelligence, ability to observe, and to remember oral messages and instructions. Messengers, who have an opportunity to travel within the immediate combat zone, generally, will have a good picture of the current situation, and are excellent prospects for tactical interrogation on the following:

- Nature and exact contents of messages he has been carrying over a reasonable period of time, as well as

names of persons who originated these messages, and names of persons to whom messages were directed. Description of duty positions of such personalities.

- Information as to extent which messengers are used in the applicable enemy unit, routes of messengers, and location of relay posts.
- Locations of message center and communications lines.

FM 34-52

- Conditions of roads, bridges, and alternate routes.
- Location of CPs and names of commanders and staff officers.
- Location of artillery, mortars, and armor seen during messenger's movement through the combat area.
- Location of minefields and other defensive installations.
- Location of supply and ammunition dumps.
- Description of terrain features behind enemy lines.
- NBC weapons, installations, and units.
- Morale and esprit de corps of civilians.
- Relocation of movement of civilians.
- Civilian supply.
- Health of civilians and medicine availability.
- Use of radio equipment in applicable enemy units.

SQUAD AND PLATOON LEADERS AND COMPANY COMMANDERS

Squad and platoon leaders, as well as company commanders, generally possess information on a broader level than discussed to this point. In addition to the information possessed by the riflemen, they may be able to furnish information on the following:

- Plans and mission of their respective units.
- Organization of their units as well as their regiment and battalion.
- Number of newly assigned unit personnel within last 30 days.
- Disposition of companies, regiments, and reserves of each.
- Identification and general organization of supporting units such as artillery, armor, and engineer units.
- Location, strength, and mission of heavy weapons units.
- Offensive and defensive tactics of small units.
- Quality and morale of subordinate troops.
- Doctrine for employment of NBC weapons.
- Doctrine for defense against NBC weapons.
- Status of NBC defense SOPs and current NBC training.
- Communications procedures and equipment.
- Issuance of NBC detection equipment and detector paints or paper.
- Morale of civilians.
- Relocation or movement of civilians.
- Civilian supply.
- Health of civilians and availability of medicine.
- Instructions on handling and evacuating US and allied prisoners.
- Night maneuvers, rehearsals, unit size, night vision devices, and special equipment.

RADIO AND TELEPHONE OPERATORS

Radio and telephone operators, like messengers, are frequently familiar with the plans and instructions of their commanders. In general, they can be expected to know the current military situation even more thoroughly because of the greater volume of information which they normally transmit. The following questions could be asked:

- Nature and exact contents of messages sent and received during a given tactical situation.
- Code names or numbers of specific enemy units—those appearing in enemy telephone directories—and in other signal operations instructions (SOI), such as unit identification panel codes.
- Major enemy units to your front and their code names.
- Units and individuals in radio nets, their call signs, call words, and operating frequencies.
- Names and code names of commanders and their staff officers.

- Types, numbers, and basic characteristics of radios and telephone equipment used at company, regiment, and division levels.
- Identification and location of units occupying front-line positions.
- Location of artillery and mortar positions.
- Information on enemy codes and ciphers.
- Code names given to operations or specially designated supply points such as for special weapons.
- Names and signals designating various types of alerts.

DRIVERS

Questions directed to captured EPW drivers of command and staff vehicles, supply vehicles, and vehicles drawing weapons should concern the aspects of the enemy situation which the prisoner would know because of his driving assignments. The following questions could be asked:

- Identification and location of CPs of higher, lower, and supporting units.
- Names and personal character traits of commanders and staff officers.
- Plans, instructions, orders, and conversations of commanders and staff officers.
- Attitudes of commanders and staff officers toward each other, civilians, units under their command, and the general military situation.
- Routes of communications and their condition.
- Tactical doctrine of commanders.
- Command and staff organization.
- Supply routes and road conditions.
- Location of supply points and types of military and civilian vehicles carrying supplies.
- Sufficiency or lack of civilian and military supplies.
- Types, numbers, and condition of military and civilian vehicles carrying supplies.
- Location of artillery and mortar positions.
- Troop movements and assembly areas.
- Location of truck parks and motor pools.
- Organization of antitank and air defense artillery (ADA) units. Include their weapons and strength.
- Location of antitank and ADA positions.
- Names of commanders of antitank and ADA units.
- Mission of antitank and ADA.
- Types and status of ammunition.
- Voluntary or forced evacuation or movement of civilians.
- Morale and health of civilians.

PATROL LEADERS AND MEMBERS

The degree of patrol activity on the enemy's part is often a good indication of enemy plans. The following can be asked:

- Specific mission of the patrol.
- Exact routes used, and time of departure and return of patrol.
- Location of enemy forward edge of the battle area (FEBA), general outpost, combat outpost, and outposts.
- Location of platoon, company, battalion, regiment, or division headquarters.
- Routes of approach and enemy positions.
- Enemy strongholds and fields of fire.
- Machine gun and mortar positions of the enemy.
- Observation and listening posts.
- Condition of bridges and location of fords.
- Description of key terrain features.
- Location and description of defensive positions such as antitank weapons, roadblocks, mines, barbed wire entanglements, gaps in wire and safe lanes, trip flares, booby traps, tank traps, and ambushes.

FM 34-52

- Other reconnaissance objectives, agencies, and patrols.
- Organization and equipment of tactical reconnaissance agencies in regiments and divisions.
- Passwords and countersigns of patrols and line units.
- Patrol communications system and range of radios.
- Names of commanders, staff officers and, particularly, enemy unit intelligence officers.
- Coordination of patrol activities with other units such as rifle companies and mortar and artillery units.
- Morale and esprit de corps of civilians.
- Relocation or movement of civilians.
- Civilian supply.
- Health of civilians and availability of medicine.

MEMBERS OF MACHINE GUN AND MORTAR UNITS

Members of machine gun and mortar units can be expected to know, on the basis of their experience or observation, the following:

- Location of their own, as well as other, machine gun and mortar positions and projected alternate positions.
- Organization, strength, casualties, and weapons of the source's unit.
- Targets for machine guns and mortars.
- Names of small-unit leaders.
- Status of weapons crew training.
- Disposition of small rifle units, squads, and platoons.
- Supply of ammunition to include type of ammunition in the basic load or on hand; for example, chemical and biological ammunition.
- Location of forward ammunition points.
- Characteristics of weapons used.
- Food and other supplies.
- Morale.
- Effect of our firepower upon their positions.
- Availability of nuclear capability.
- Number of newly assigned personnel to the unit within last 30 days.

LIAISON OFFICERS

The liaison officer is the commander's agent for accomplishing coordination among the headquarters of lower, adjacent, and higher units. The liaison officer also may be called upon to effect coordination between infantry units and supporting or supported armor and artillery, engineer, and reconnaissance units.

- Contents of field orders, such as composition of attacking forces—location and direction of attack; missions of individual units; objectives; plans for attack, defense, or withdrawals; and plans for communication and coordination among units.
- Location of lower, adjacent, higher, and supporting unit CPs as well as location of supply and communications installations.
- Locations of observation posts and outposts.
- Assembly areas for troops and location of supply points.
- Disposition of regiments, battalions, and companies of a division.
- Identification and disposition of reserves.
- Status of supplies of all types.
- Civilian social and economic conditions.
- Evacuation or movement of civilians.

ARMORED TROOPS

Armored troops are good interrogation prospects concerning enemy tank tactics, communications, logistics, and based on combat experience, mines, traps, and ambushes. Topics for interrogation should cover—

- Unit identifications.
- Designation and strength of supporting or supported infantry units.
- Types and characteristics of tanks employed.
- Mechanical and tactical weaknesses of these tanks.
- Means of communications between tanks and between tanks and infantry.
- Missions and objectives.
- Routes of approach.
- Armored units in reserve.
- Location of tank parks and assembly areas.
- Location of impassable terrain features.
- Methods of mortar, artillery, and tank coordination.
- Location of tank repair depots and petroleum, oils, and lubricants (POL) dumps (to include resupply and refueling techniques).

- Effect of weather on tank operations.
- Armored reconnaissance missions.
- Number of newly assigned personnel in unit within last 30 days.
- Morale and esprit de corps of civilians.
- Relocation or movement of civilians.
- Civilian supply.
- Health of civilians and availability of medicine.
- Status of ammunition and POL resupply.
- Location of ammunition supply points.
- Ammunition supply to include type in the basic load or on hand; for example, chemical ammunition.
- Measures for defense against NBC and radiological attack, to include type of NBC defensive equipment installed in the tank.
- Night maneuvers, rehearsals, unit size, night vision devices, and special equipment.

ARTILLERYMEN

Topics to be covered when questioning captured artillerymen are broken down as follows by forward observers, artillery firing battery personnel, and air defense artillerymen.

FORWARD OBSERVERS

- Location, organization, and number of guns of the battery or battalion whose fire the source was observing and directing.
- Location of front lines, outposts, and observation posts.
- Location of alternate observation posts.
- Location and probable time of occupation of present or alternate gun positions.
- Deployment of artillery.
- Characteristics of guns, including caliber and range.

- Targets for various types of fire during different phases of combat.
- Nature of the infantry artillery communication net.
- Type and location of artillery fire requested by infantry units.
- Identification of corps or other supporting artillery units.
- Plan of attack, defense, or withdrawal of enemy units.
- Methods of coordinating artillery fire with infantry maneuver.
- Mission and objectives of source's unit as well as of supported units.
- Routes of approach and their condition. Characteristics of terrain features.

FM 34-52

- Methods of observing and directing artillery fire, including information such as types of aircraft employed.
 - Methods of counterbattery fire and protecting enemy positions from counterbattery fire.
 - Use and location of dummy artillery positions.
 - Types of artillery ammunition used for various targets, new types of ammunition, conservation of fires and reasons for conservation.
 - Location of artillery and infantry unit CPs.
 - Trafficability of routes appropriate for movement of heavy artillery.
 - Names of commanders, staff officers, and their attitudes toward each other and infantry commanders.
 - Number of newly assigned personnel to the unit within last 30 days.
 - Effect of our artillery upon enemy units.
 - Location and numbering of defensive concentrations.
 - Location of ammunition supply points.
 - Radio channels used for fire control nets.
 - Identification and location of supporting battalions.
 - Availability of nuclear fire support.
 - Morale and esprit de corps of civilians.
 - Relocation or movement of civilians.
 - Civilian supply.
 - Health of civilians and availability of medicine.
- ARTILLERY FIRING
BATTERY PERSONNEL**
- Measures of defense against friendly artillery fire.
 - Counterbattery protection for artillery installations.
 - Effect of friendly counterbattery fire.
 - Location of battery ammunition points.
 - Disposition of local security weapons.
 - Direction and elevation of fire.
 - Instructions concerning ammunition use.
 - Names of battery and other commanders.
 - Detailed description of artillery weapons used.
 - Status of weapons crew training.
 - Information on food supplies and morale of military and civilians.
 - Measures for defense against NBC attack.
 - Types and amount of ammunition, to include chemical and nuclear, in basic load or on hand.
 - Location of chemical and biological ammunition.
 - Location targets marked for chemical and biological fires.

AIR DEFENSE ARTILLERYMEN

- Location and number of air defense weapons.
- Detailed description and characteristics of air defense guns and missiles used.
- Shape, size, and location of ground radars.
- Organization of air defense units.
- Types of areas defended.
- Nuclear capability.
- Methods of attack against friendly aircraft, by type of aircraft.
- Avenues of approach and altitudes most and least advantageous to enemy air defense.
- Methods of identifying unknown aircraft.

MEDICAL CORPSMEN

Although medical personnel are entitled to special protective measures under international agreements, they can be and are interrogated without infringement of any existing laws or rules of warfare. The following questions could be asked:

- Number of casualties over a given phase of combat operations.
- Weapons accounting for most casualties.
- Key personnel who have been casualties.

- Conditions of health and sanitation in enemy units.
- Ratio of dead to wounded.
- Commander's tactics in relation to number of casualties.
- Adequacy and efficiency of casualty evacuation.
- Weapons most feared by the enemy.
- Location and staffing of aid stations and hospitals.
- Organization of division, regiment, and battalion medical units.
- Status and types of medical supplies.
- Use and characteristics of newly developed medicine or drugs.
- Data on wounded, sick, or dead in enemy hands.
- Skill of enemy medical personnel.
- Information on mass sickness or epidemics in the enemy forces.
- Types of treatment and medication for NBC casualties.
- Supply and availability of materials used in treatment of NBC casualties.
- Special training or treatment of NBC casualties.
- New or recent immunizations.
- Morale and esprit de corps of civilians.
- Relocation or movement of civilians.
- Civilian supply.
- Health of civilians and availability of medicine.
- Location and present condition of civilian hospitals, factories producing medical supplies, and warehouse and stores containing medical supplies.

ENGINEER TROOPS

Engineer personnel are prime interrogation candidates for information concerning bridges, fortifications, minefields, and coordination between infantry and supported units. Topics to be covered are—

- Mission of supported unit.
- Exact location and pattern of existing minefields, location of bridges, buildings, airfields, and other installations prepared for demolition, and types of mines of explosives used.
- Doctrine pertaining to the use of mines and booby traps to include types of mines, characteristics of firing devices, and minefields patterns.
- Location of roadblocks and tank traps and how they are constructed.
- Conditions of roads, bridges, and streams or rivers for trafficability of personnel, vehicles, and armor; weight-carrying capacity of bridges and location and description of fords.
- Location of engineer materials and equipment such as road material, bridge timber, lumber, steel, explosives, quarries, rock crushers, sawmills, and machine shops.
- Location of dummy vehicles and tank and gun positions.
- Location of camouflaged positions and installations.
- Water supply and locations of water points.
- Organization, strength, and weapons of engineer units.
- Presence of other than organic engineer units at the front, and mission of such units.
- Number of trucks, tractors, and other engineer vehicles available.
- Location of new or repaired bridges.
- Use of demolitions.
- Morale and esprit de corps of civilians.
- Relocation or movement of civilians.
- Civilian supply.
- Health of civilians and availability of medicine.
- Location and present conditions of civilian power plants, water works, and sewage disposal plants.
- Night maneuvers, rehearsals, unit size, night vision devices, and special equipment.

FM 34-52

RECONNAISSANCE TROOPS

Reconnaissance personnel and degree of activity are good indicators on enemy intentions. Topics for questioning are—

- The reconnaissance plan, march order, time schedule, and specific missions of all elements, means of coordination and communication between elements, and unit and higher headquarters.
- Nature of orders received from higher headquarters.
- Identification, organization, composition, strength, means of transportation, and weapons of the unit.
- Routes of approach used by the unit.
- Identification, composition, organization, strength, and disposition of the main body of troops and reinforcements. Routes to be used.
- General quality of troops of the reconnaissance unit and of the main body.
- Radio communication equipment and frequencies used.
- Night maneuvers, rehearsals, unit size, night vision devices, and special equipment.

LOCAL CIVILIANS

Civilians who recently left enemy-held areas normally have important information, and often give this information readily.

This information is usually important to CA and PSYOP personnel. The following questions could be asked:

- Location of enemy front lines and major defensive positions.
- Location of artillery positions.
- Location and nature of minefields in enemy rear area.
- Description of key terrain.
- Condition of roads, bridges, and major buildings.
- Enemy policy and attitude toward local civilians.
- Human and material resources of the area.
- Morale and esprit de corps of local civilians.
- Data on important civilian personalities remaining in enemy areas.
- Health and medical status of local populace.
- Effect of friendly operations on civilian populace.
- Instructions to prepare for defensive measures against NBC attack.
- Recent immunizations.

POLITICAL AND PROPAGANDA PERSONNEL

Personnel recently acquired through combat operations and identified as involved with political and PSYOP should be questioned as follows:

- Policy, plans, and objectives.
- Organization and training.
- Current and past activities, to include themes of any propaganda programs.
- Enemy analysis of our weaknesses and strengths.
- Target audiences for propaganda, including priorities.
- Effects of our PSYOP.
- Analysis of enemy weaknesses and strengths.
- Enemy counterpropaganda activities.

GUERRILLA PERSONNEL

Guerrilla personnel, depending of assignment, can be expected to have information concerning activities,

strength, equipment, leadership, and local influence or support. Topics to be covered are—

B-8

- Area of activities.
- Nature of activities.
- Strength.
- Equipment.
- Motivation.
- Leadership.
- Reliability.
- Contacts.
- External direction or support.

NBC OPERATIONS

The following topics are of interest when interrogating personnel about NBC operations:

- What items of NBC protective equipment have been issued to troops? Is there any differentiation in issue of items for particular areas? If so, what items for what areas?
- Are there any new or recent immunizations indicated by sources during interrogations?
- What immunizations have troop units received, as indicated in captured immunization records?
- Are troops equipped with protective masks? Is the individual required to carry the mask on his person? Are there any sectors where the mask is not required equipment for the individual? What accessory equipment is issued with the mask?
- Is protective equipment issued to troops? If so, what type of clothing or articles? If special clothing is used, is it for any particular geographic area?
- Have troop units constructed NBC protective shelters? If so, what type?
- Are fortification, individual and collective, provided with overhead cover?
- Are troops issued any protective footwear or other means to provide protection against penetration by liquid agents?
- Are tanks and armored vehicles provided with specially installed protective equipment to protect the crew in case of chemical attack?
- Are troops issued any type of individual protective items for first aid, such as antidotes or protective ointment?
- Are there any areas for which additional or unusual NBC safety precautions have been established?
- What is the size and composition of NBC specialist troop units? Where are they located? Why?
- Have troops been issued any special precautionary instructions concerning consumption of food and water or handling of livestock in areas that may be overrun by enemy forces?
- What training, if any, have troops received in the use of incapacitating-type agents and their dissemination?
- What items of chemical detection equipment have been issued to troops? Are the items operated continuously, irregularly, or not at all? Is there any differentiation made regarding their use in certain areas?
- What type radiation-measuring instruments are issued to troop units and what is their range or limit? How are they distributed?
- How many hours of training with radiation-measuring instruments have monitoring and survey personnel received?
- How many hours of NBC training have troops received? How many hours of individual training are devoted to chemical, biological, and radiological operations? Have troops received any special or accelerated training above what is considered routine?
- Do units have decontamination materials on hand? If so, what type and quantity?
- Have you observed decontamination stations or installations established in your area? If so, what are their location and composition?
- Are troop units issued biological sampling kits or devices? If so, what is their type and composition?
- Have you observed any cylinders or containers which might contain bulk chemical agents?

FM 34-52

- Have you observed any tactical aircraft equipped with accessory tanks which indicated a spray capability?
- Are you aware of location of dumps of chemical-filled ammunition, bombs, clusters, and bulk chemical agents?
- Do artillery, mortar, or rocket units have chemical ammunition on hand?
- At what radiological exposure or dose are troops required to relocate?
- Are there any problem areas or shortcomings in NBC material?

NOTE: The following are applicable or internal defense operations in appropriate theaters of operations.

- What types of tunnels, caves, and modifications are used in defense against riot control agents and explosive gases?
- What defensive material and instructions are issued for defense against riot control agents?
- What defensive measures are taken against defoliation and anticrop agents?

OVERALL OBJECTIVE STATEMENT

Figure B-1 shows a sample overall objective statement for an interrogation element in division GS. It is not all inclusive. PIR and IR shown are not comprehensive and

are used as subheadings with intelligence indicators grouped under each. Figure B-2 contains an overall objective statement that includes the six IEW tasks.

<p style="text-align: center;">PRIORITY INTELLIGENCE REQUIREMENTS</p> <p>I. NBC WEAPONS.</p> <ol style="list-style-type: none">1. Are NBC weapons present in any of the brigade sectors?2. When will these NBC weapons be used?3. Where will these NBC weapons be used?4. How many of these NBC weapons will be used against each target?5. What systems will deliver these NBC weapons? <p>II. ENEMY ATTACK.</p> <ol style="list-style-type: none">1. When will the enemy attack?2. Where will the enemy attack?3. What is the attack's main objective?4. What units will conduct the attack?5. What is the combat effectiveness of attack units?6. What artillery groups, regimental or divisional, will support the attack?7. Where are these artillery groups located? <p>III. ENEMY DEFENSE.</p> <ol style="list-style-type: none">1. Where will the enemy establish lines of defense?2. What enemy units have been assigned to each defensive belt?3. What is the combat effectiveness of the units assigned to each defensive belt?4. What types of antitank weapons have been assigned to each defensive belt?5. What obstacles have been emplaced in each defensive belt?6. What minefields have been emplaced in each defensive belt?7. What enemy units comprise the reaction force to counter friendly armor or heliborne assaults?8. What types of artillery are assigned to support the defense?9. Where is this artillery located? <p>IV. ENEMY RETREAT.</p> <ol style="list-style-type: none">1. What units will take part in the retreat?2. What are the current positions of the retreating units?3. When will each of the retreating units begin its movement?4. What routes will be taken by the retreating units?5. What units have been designated the rear guard for the retreat?

Figure B-1. Sample overall objective statement.

FM 34-52

<p>6. What units have been designated the covering force for the retreat?</p> <p>7. Where will each of the retreating units establish new positions?</p> <p>8. What types of artillery have been assigned to support the retreat?</p> <p>9. What deception efforts will be made to conceal the retreat?</p> <p>V . ENEMY REINFORCEMENT.</p> <p>1. What units comprise the enemy's second echelon?</p> <p>2. What is the combat effectiveness of the units in the enemy's second echelon?</p> <p>3. What is the direction of travel for each unit in the enemy's second echelon?</p> <p>4. How soon will units in the enemy's second echelon begin to enter each brigade's AO?</p> <p>5. What units within the enemy's first echelon will receive reinforcements of personnel or equipment?</p> <p>6. To what extent will these units be reinforced?</p> <p>7. How soon will these reinforcements arrive?</p> <p>8. By what routes will these reinforcements arrive?</p> <p style="text-align: center;">INFORMATION REQUIREMENTS</p> <p>I. SUPPLY POINTS.</p> <p>1. What types of ammunition is the enemy stockpiling?</p> <p>2. What are the types of POL the enemy is stockpiling?</p> <p>3. Where are these supply points located?</p> <p>4. What units are serviced by these supply points?</p> <p>5. How much materiel is currently stockpiled at these locations?</p> <p>II. VULNERABILITIES.</p> <p>1. What malfunctions are occurring with the enemy's--</p> <p style="padding-left: 20px;">a. Weapons?</p> <p style="padding-left: 20px;">b. Vehicles?</p> <p style="padding-left: 20px;">c. Communications?</p> <p style="padding-left: 20px;">d. Ammunition?</p> <p>2. What are the enemy's major supply routes?</p> <p>3. How often are supplies transported over these routes?</p> <p>4. What transportation priority has the enemy assigned to each category of supplies?</p> <p>5. What choke points has the enemy identified along his own lines of communications?</p>

Figure B-1. Sample overall objective statement (continued).

- I. SITUATION DEVELOPMENT.
1. Are NBC weapons present in any of the brigade sectors?
 - a. Have any tracked, self-propelled rocket launchers been sighted within any of the brigade sectors?
 - b. Have any small convoys been sighted traveling under unusually heavy security within any of the brigade sectors?
 - c. Have light aircraft been sighted circling over convoys moving in any of the brigade sectors?
 - d. Have any noncommunications emitters normally associated with NBC weapons been identified in any brigade sector?
 - e. Have any installations with unusually heavy security been identified within any of the brigade sectors?
 - f. Have any tall, slender objects (such as towers, chimneys, or narrow trees) suddenly appeared in any of the brigade sectors?
 2. When will these NBC weapons be used?
 - a. Have contingency orders been received by any enemy units in any of the brigade sectors which indicate circumstances under which NBC weapons will be used?
 - b. Have code words been disseminated to alert enemy troops that NBC weapons will be used in any of the brigade sectors?
 - c. What procedures are to be followed by enemy troops in any brigade sector immediately following receipt of alert codes?
 - d. Have any front-line enemy troops in any brigade sector inexplicably slowed or halted their advance?
 - e. Has any very heavy artillery been moved to within supporting distance of front-line enemy troops within any brigade sector?
 - f. Has random firing of very heavy artillery occurred within any of the brigade sectors?
 3. Where will these NBC weapons be used?
 - a. Have all known enemy agents suddenly disappeared from any areas within any of the brigade sectors?
 - b. Has enemy air activity suddenly increased in any areas within any of the brigade sectors?
 - c. Is unusual enemy air activity taking place in any areas within any of the brigade sectors?
 - d. Is smoke being used or planned for use as cover for any front-line enemy troops in any of the brigade sectors?
 - e. Have specific areas within any brigade sector been identified as targets for NBC weapons?

Figure B-2. Sample overall objective statement (IEW tasks).

FM 34-52

- f. Have orders been received by any enemy units in any brigade sector which indicate that NBC weapons might be used in support of their activities?
4. How many of these NBC weapons will be used against each target?
- a. How many very heavy artillery dispositions have been identified within each brigade sector?
- b. How many noncommunications emitters associated with NBC weapons have been identified within each brigade sector?
- c. How many transporter-erector-launchers (TELS) have been sighted within each brigade sector?
- d. How many enemy units within each brigade sector have been notified that NBC weapons might be used to support them?
- e. How many front-line enemy units within each brigade sector have inexplicably slowed or stopped their advance?
5. What types of systems will be used to deliver these NBC weapons?
- a. What calibers of very heavy artillery have been identified within each of the brigade sectors?
- b. What types of TELS have been identified within each brigade sector?
- c. What types of chemical agents have been identified within each brigade sector?
- d. What types of biological agents have been identified within each brigade sector?
- e. What types of noncommunications emitters have been identified within each brigade sector?
6. When will the enemy attack?
- a. Have any enemy units in any of the brigade sectors received orders to conduct assault operations?
- b. Is the enemy massing mechanized infantry units in any of the brigade sectors?
- c. Is the enemy massing armor units in any of the brigade sectors?
- d. Is the enemy massing artillery units in any of the brigade sectors?
- e. Are front-line enemy troops disposed along relatively narrow fronts in any areas within any of the brigade sectors?
- f. What rumors indicating future offensive operations are circulating within enemy units in each brigade sector?
7. Where will the enemy attack?
- a. What avenues of approach will be used by specific enemy units within each brigade sector?
- b. How many enemy units will use each avenue of approach within each brigade sector?

Figure B-2. Sample overall objective statement (IEW tasks) (continued).

- c. Where are the enemy's large concentrations of mechanized infantry units within each brigade sector?
- d. Where are the enemy's large concentrations of armor units within each brigade sector?
- e. Where are the enemy's large concentrations of artillery units within each brigade sector?
- 8. What is the attack's main objective?
 - a. What objectives have been assigned to specific enemy units in each brigade sector for their offensive operations?
 - b. How many objectives have been assigned to specific enemy units in each brigade sector for their offensive operations?
 - c. How many enemy units within each brigade sector have been assigned the same objectives?
- 9. What units have been assigned to conduct the attack?
 - a. What enemy units in any of the brigade sectors have received orders to conduct assault operations?
 - b. What enemy units are rumored to be preparing to conduct offensive operations within any of the brigade sectors?
 - c. What enemy units have been assigned to use specific avenues of approach within each brigade sector?
 - d. What specific enemy units have been assigned the same objectives within each brigade sector?
- 10. What is the combat effectiveness of the units assigned to conduct the attack?
 - a. How many personnel are currently fit for duty within the specific enemy units assigned to conduct offensive operations in any of the brigade sectors?
 - b. How many vehicles are currently operational within the specific enemy units assigned to conduct offensive operations in any of the brigade sectors?
 - c. How many weapon systems are currently operational within the specific enemy units assigned to conduct offensive operations in any of the brigade sectors?
 - d. What is the morale of the personnel assigned to the specific enemy units assigned to conduct offensive operations in any of the brigade sectors?
- 11. What artillery groups, regimental or divisional, have been assigned to support the attack?
 - a. What artillery units have been ordered to support the enemy regiments or divisions assigned to conduct offensive operations in each of the brigade sectors?
 - b. What artillery assets have been identified within supporting distance of the enemy regiments or divisions assigned to conduct offensive operations?
 - c. What types of noncommunications emitters associated with regimental or divisional artillery groups have been identified within each of the brigade sectors?

Figure B-2. Sample overall objective statement (IEW tasks) (continued).

FM 34-52

12. Where will the enemy establish lines of defense?
 - a. Where are enemy units preparing extensive field fortifications within each brigade sector?
 - b. Where are enemy units establishing antitank strong points within each brigade sector?
 - c. To which front-line enemy units within each brigade sector are antitank units being attached?
 - d. Where are alternate artillery positions being prepared within each brigade sector?
 - e. Where are obstacles being emplaced within each brigade sector?
 - f. Where are mines being emplaced within each brigade sector?
13. What enemy units have been assigned to each defensive belt?
 - a. What specific enemy units are preparing extensive field fortifications within each brigade sector?
 - b. What specific enemy units are establishing antitank strong points within each brigade sector?
 - c. What specific enemy units within each brigade sector are receiving attached antitank units?
 - d. What specific enemy units within each brigade sector are preparing alternate artillery positions?
 - e. What specific enemy units are emplacing obstacles within each brigade sector?
 - f. What specific enemy units are emplacing mines within each brigade sector?
14. What is the combat effectiveness of the units assigned to each defensive belt?
 - a. How many personnel are currently fit for duty within the specific enemy units assigned to the defensive belts in each brigade sector?
 - b. How many vehicles are currently operational within the specific enemy units assigned to the defensive belts in each brigade sector?
 - c. How many weapons systems are currently operational within the specific enemy units assigned to the defensive belts in each brigade sector?
 - d. What is the morale of the personnel assigned to the specific enemy units assigned to the defensive belts in each brigade sector?
15. What types of antitank weapons have been assigned to each defensive belt?
 - a. What types of antitank weapons are possessed by the specific enemy units assigned to the defensive belts in each brigade sector?
 - b. What types of antitank units have been attached to specific enemy units assigned to the defensive belts in each brigade sector?

Figure B-2. Sample overall objective statement (IEW tasks) (continued).

16. What obstacles have been emplaced in each defensive belt?
 - a. What natural obstacles have been incorporated into the defensive belts in each brigade sector?
 - b. What manmade antipersonnel obstacles have been emplaced by the specific enemy units assigned to the defensive belts within each brigade sector?
 - c. What manmade anti-vehicular obstacles have been emplaced by the specific enemy units assigned to the defensive belts within each brigade sector?
17. What minefields have been emplaced in each defensive belt?
 - a. What types of antipersonnel mines are being emplaced by the specific enemy units assigned to the defensive belts in each brigade sector?
 - b. What types of antitank mines are being emplaced by the specific enemy units assigned to the defensive belts in each brigade sector?
18. What units comprise the reaction force to counter friendly armor or airborne assaults?
 - a. What enemy units have received orders to act as the reaction force for defensive positions in each brigade sector?
 - b. What enemy units are rumored to be the reaction force for defensive positions in each brigade sector?
 - c. What enemy units are located behind, but in proximity to, the defensive positions in each brigade sector?
19. What types of artillery are assigned to support the defense?
 - a. What enemy artillery units have received orders to support the defensive positions in each brigade sector?
 - b. What enemy artillery units are rumored to be supporting the defensive positions in each brigade sector?
 - c. What types of artillery have been identified within each brigade sector?
20. Where is this artillery located?
 - a. What is the current location of the enemy artillery units ordered to support the defensive positions in each brigade sector?
 - b. What is the current location of the enemy artillery units rumored to be supporting the defensive positions in each brigade sector?
 - c. What is the current location of all artillery identified within each brigade sector?
21. What units will take part in the retreat?
 - a. What enemy units in each brigade sector have received orders to participate in a retreat?
 - b. What enemy units in each brigade sector are rumored to be participating in a retreat?
 - c. What enemy units within each brigade sector are disposed along an extended front?

Figure B-2. Sample overall objective statement (IEW tasks) (continued).

FM 34-52

- d. What enemy units in each brigade sector have been notified their artillery support is moving to the rear?
- e. What enemy units in each brigade sector have been notified their logistical support is moving to the rear?
- 22. What are the current positions of the retreating units?
 - a. What is the current location of enemy units in each brigade sector ordered to participate in a retreat?
 - b. What is the current location of enemy units in each brigade sector rumored to be participating in a retreat?
 - c. What is the current location of enemy units within each brigade sector disposed along an extended front?
 - d. What is the current location of artillery units supporting enemy units in each brigade sector?
 - e. What is the current location of logistical units supporting enemy units in each brigade sector?
- 23. When will each of the retreating units begin its movement?
 - a. At what time have specific enemy units in each brigade sector been ordered to begin their retreat?
 - b. What start times are being mentioned in rumors about the retreat of specific enemy units in each brigade sector?
- 24. What routes will be taken by the retreating units?
 - a. What movement routes have been assigned for the retreat of specific enemy units in each brigade sector?
 - b. What movement routes are being cited in rumors about the retreat of specific enemy units in each brigade sector?
 - c. What movement routes are being used or planned for use during the retreat of enemy artillery units in each brigade sector?
 - d. What movement routes are being used or planned for use during the retreat of enemy logistical units in each brigade sector?
- 25. What units have been designated the rear guard for the retreat?
 - a. What specific enemy units have been ordered to act as rear guard for the retreat in each brigade sector?
 - b. What specific enemy units are rumored to be rear guard for the retreat in each brigade sector?
- 26. What units have been designated the covering force for the retreat?
 - a. What specific enemy units have been ordered to act as covering force for the retreat in each brigade sector?
 - b. What specific enemy units are rumored to be covering force for the retreat in each brigade sector?

Figure B-2. Sample overall objective statement (IEW tasks) (continued).

27. Where will each of the retreating units establish new positions?
- Where are the new positions assigned to retreating enemy units in each brigade sector?
 - What are the new positions being cited in rumors about the retreat of enemy units in each brigade sector?
 - Where are the new positions assigned to retreating enemy artillery units in each brigade sector?
 - Where are the new positions assigned to retreating enemy logistical units in each brigade sector?
28. What types of artillery have been assigned to support the retreat?
- What specific enemy artillery units have been assigned to support the retreat in each brigade sector?
 - What specific enemy artillery units are rumored to be supporting the retreat in each brigade sector?
29. What deception efforts will be made to conceal the retreat?
- What deception efforts have been ordered in conjunction with the retreat in each brigade sector?
 - What specific enemy units are conducting deception efforts in conjunction with the retreat in each brigade sector?
 - What deception efforts are being cited in rumors about the retreat in each brigade sector?
 - What enemy units are rumored to be conducting deception efforts in conjunction with the retreat in each brigade sector?
30. What units comprise the enemy's second echelon?
- What specific units are known to be part of the enemy's second echelon in each brigade sector?
 - What specific units are rumored to be part of the enemy's second echelon in each brigade sector?
 - How many units comprise the enemy's second echelon in each brigade sector?
 - What type of units comprise the enemy's second echelon in each brigade sector?
31. What is the combat effectiveness of the units in the enemy's second echelon?
- How many personnel are currently fit for duty within the specific enemy units comprising the second echelon in each brigade sector?
 - How many vehicles are currently operational within the specific enemy units comprising the second echelon in each brigade sector?
 - How many weapons systems are currently operational within the specific enemy units comprising the second echelon in each brigade sector.

Figure B-2. Sample overall objective statement (IEW tasks) (continued).

FM 34-52

- d. What is the morale of the personnel assigned to the specific enemy units comprising the second echelon in each brigade sector?
32. What is the direction of travel for each unit in the enemy's second echelon?
- a. What is the known direction of travel for units comprising the enemy's second echelon in each brigade sector?
- b. What are the known movement routes for units comprising the enemy's second echelon in each brigade sector?
- c. What is the rumored direction of travel for units comprising the enemy's second echelon in each brigade sector?
- d. What are the rumored movement routes for units comprising the enemy's second echelon in each brigade sector?
33. How soon will units in the enemy's second echelon begin to enter each brigade's AO?
- a. What is the current known location of units comprising the enemy's second echelon in each brigade sector?
- b. What is the current rumored location of units comprising the enemy's second echelon in each brigade sector?
- c. What is the known rate of travel for units comprising the enemy's second echelon in each brigade sector?
- d. What is the rumored rate of travel for units comprising the enemy's second echelon in each brigade sector?
34. What units within the enemy's first echelon will receive reinforcements of personnel or equipment?
- a. What personnel or equipment replacement have been ordered for specific front-line enemy units in each brigade sector?
- b. What specific front-line enemy units in each brigade sector are rumored to be receiving personnel or equipment replacements?
35. To what extent will these units be reinforced?
- a. How many personnel replacements have been ordered for specific enemy units in each brigade sector?
- b. How many personnel are cited in the rumors concerning replacements for specific enemy units in each brigade sector?
- c. How much lost equipment has been ordered replaced in specific enemy units in each brigade sector?
- d. How much equipment is cited in the rumors concerning replacements for specific enemy units in each brigade sector?
36. How soon will these reinforcements arrive?
- a. At what time will scheduled personnel replacements arrive at specific enemy units in each brigade sector?

Figure B-2. Sample overall objective statement (IEW tasks) (continued).

B-20

- b. At what time will scheduled equipment replacements arrive at specific enemy units in each brigade sector?
 - c. What time is cited in rumors concerning personnel replacements for specific enemy units in each brigade sector?
 - d. What time is cited in rumors concerning equipment replacements for specific enemy units in each brigade sector?
37. By what routes will these reinforcements arrive?
- a. What is the current known location of personnel and equipment replacements for specific enemy units in each brigade sector?
 - b. What is the current rumored location of personnel and equipment replacements for specific enemy units in each brigade sector?
 - c. What are the known movement routes of personnel and equipment replacements for specific enemy units in each brigade sector?
 - d. What are the rumored movement routes for personnel and equipment replacements for specific enemy units in each brigade sector?
38. What type of ammunition is the enemy stockpiling?
- a. What type of small arms ammunition is the enemy stockpiling in each brigade sector?
 - b. What type of ammunition is the enemy stockpiling for crew-served weapons in each brigade sector?
 - c. What type of ammunition is the enemy stockpiling for armored vehicles in each brigade sector?
 - d. What type of artillery ammunition is the enemy stockpiling in each brigade sector?
39. What type of POL is the enemy stockpiling?
- a. What type of fuel is the enemy stockpiling in each brigade sector?
 - b. What type of oil is the enemy stockpiling in each brigade sector?
 - c. What type of lubricants is the enemy stockpiling in each brigade sector?
40. Where are these supply points located?
- a. Where are the enemy's ammunition supply points located in each brigade sector?
 - b. Where are the enemy's POL supply points located in each brigade sector?
41. What units are serviced by these supply points?
- a. What ammunition supply points support specific enemy units in each brigade sector?
 - b. What POL supply points support specific enemy units in each brigade sector?

Figure B-2. Sample overall objective statement (IEW tasks) (continued).

FM 34-52

42. How much material is currently stockpiled at these locations?
- a. How much ammunition is stockpiled at specific supply points in each brigade sector?
 - b. How much POL are stockpiled at specific supply points in each brigade sector?
43. What malfunctions are occurring with the enemy's weapons?
- a. What malfunctions are occurring with the enemy's small arms in each brigade sector?
 - b. What malfunctions are occurring with the enemy's crew-served weapons in each brigade sector?
 - c. What malfunctions are occurring with the enemy's artillery in each brigade sector?
44. What malfunctions are occurring with the enemy's vehicles?
- a. What malfunctions are occurring with the enemy's tracked vehicles in each brigade sector?
 - b. What malfunctions are occurring with the enemy's wheeled vehicles in each brigade sector?
45. What malfunctions are occurring with enemy communications?
- a. What malfunctions are occurring with enemy vehicle-mounted communications equipment in each brigade sector?
 - b. What malfunctions are occurring with enemy manpacked communications equipment in each brigade sector?
 - c. What malfunctions are occurring with enemy pyrotechnic means of communication in each brigade sector?
46. What malfunctions are occurring with enemy ammunition?
- a. What malfunctions are occurring with enemy small arms ammunition in each brigade sector?
 - b. What malfunctions are occurring with enemy artillery ammunition in each brigade sector?
 - c. What malfunctions are occurring with enemy ammunition for armored vehicles in each brigade sector?
 - d. What malfunctions are occurring with enemy ammunition for crew-served weapons in each brigade sector?
47. What are enemy main supply routes?
- a. What are the known movement routes used by enemy supply convoys in each brigade sector?
 - b. What movement routes are rumored to be used by enemy supply convoys in each of the brigade sectors?

Figure B-2. Sample overall objective statement (IEW tasks) (continued).

- c. What is the known direction of travel for enemy supply convoys passing named areas of interest (NAIs) in each brigade sector?
- d. What direction of travel is rumored for enemy supply convoys passing NAIs in each brigade sector?
- 48. How often are supplies transported over these routes?
 - a. How often are specific enemy units in each brigade sector resupplied?
 - b. How often are enemy supply convoys sighted along established movement routes in each brigade sector?
- 49. What transportation priority has the enemy assigned to each category of supplies?
 - a. What is the enemy's known transportation priority for each category of supplies in each brigade sector?
 - b. What is rumored to be the enemy's transportation priority for each category of supplies in each brigade sector?
 - c. What is the frequency with which specific enemy units in each brigade sector receive each category of supplies?
- 50. What choke points has the enemy identified along his own LOCs?
 - a. What choke points are known to exist along the enemy's LOCs in each brigade sector?
 - b. What choke points are rumored to exist along the enemy's LOCs in each brigade sector?
- II. TARGET DEVELOPMENT AND ACQUISITION.
 - 1. Are NBC weapons present in any of the brigade sectors?
 - a. Where have tracked, self-propelled rocket launchers been sighted within any of the brigade sectors?
 - b. What was the direction of travel of any small convoys sighted traveling under unusually heavy security in any of the brigade sectors?
 - c. Where have light aircraft been sighted circling over convoys moving in any of the brigade sectors?
 - d. Where have noncommunications emitters normally associated with NBC weapons been identified in any brigade sectors?
 - e. Where have installations with unusually heavy security been identified within any of the brigade sectors?
 - f. Where have tall, slender objects (such as towers, chimneys, or narrow trees) suddenly appeared in any of the brigade sectors?
 - 2. Where will these NBC weapons be used?
 - a. Where has enemy air activity suddenly increased within any of the brigade sectors?

Figure B-2. Sample overall objective statement (IEW tasks) (continued).

FM 34-52

- b. Where is unusual enemy air activity taking place within any of the brigade sectors?
 - c. Where is smoke being used or planned for use as cover for any front-line enemy troops in any of the brigade sectors?
 - d. Where has very heavy artillery been moved to within supporting distance of front-line enemy troops within any brigade sector?
 - e. Where has random firing of very heavy artillery occurred within any of the brigade sectors?
3. Where will the enemy attack?
- a. Where are the enemy's large concentrations of mechanized infantry units within each brigade sector?
 - b. Where are the enemy's large concentrations of armor units within each brigade sector?
 - c. Where are the enemy's large concentrations of artillery units within each brigade sector?
4. What artillery groups, regimental or divisional, have been assigned to support the attack?
- a. What artillery units have been ordered to support the enemy regiments or divisions assigned to conduct offensive operations in each of the brigade sectors?
 - b. How many artillery dispositions have been identified within supporting distance of the enemy regiments or divisions assigned to conduct offensive operations?
5. Where will the enemy establish lines of defense?
- a. Where are enemy units preparing extensive field fortifications within each brigade sector?
 - b. Where are enemy units establishing antitank strong points within each brigade sector?
 - c. Where are alternate artillery positions being prepared within each brigade sector?
 - d. Where are obstacles being emplaced within each brigade sector?
 - e. Where are mines being emplaced within each brigade sector?
6. What units comprise the reaction force to counter friendly armor or airborne assaults?
- a. What is the location of the enemy units ordered to act as the reaction force for defensive positions in each brigade sector?
 - b. What is the location of the enemy units rumored to be the reaction force for defensive positions in each brigade sector?
7. What is the location of artillery units assigned to support the enemy's defense?
- a. What is the current location of the enemy artillery units ordered to support the defensive positions in each brigade sector?

Figure B-2. Sample overall objective statement (IEW tasks) (continued).

B-24

- b. What is the current location of the enemy artillery units rumored to be supporting the defensive positions in each brigade sector?
8. What are the current positions of retreating enemy units?
- a. What is the current location of enemy units in each brigade sector that have been ordered to participate in a retreat?
- b. What is the current location of enemy units in each brigade sector that are rumored to be participating in a retreat?
- c. What is the current location of enemy units within each brigade sector disposed along an extended front?
- d. What is the current location of artillery units supporting enemy units in each brigade sector?
- e. What is the current location of logistical units supporting enemy units in each brigade sector?
9. What routes will be taken by retreating enemy units?
- a. What movement routes have been assigned for the retreat of specific enemy units in each brigade sector?
- b. What movement routes are being cited in rumors about the retreat of specific enemy units in each brigade sector?
- c. What movement routes are being used or planned for use during the retreat of enemy –
- (1) Artillery units in each brigade sector?
- (2) Logistical units in each brigade sector?
10. Where will each retreating enemy unit establish its new position?
- a. Where are the new positions assigned to retreating enemy units in each brigade sector?
- b. What are the new positions being cited in rumors about the retreat of enemy units in each brigade sector?
- c. Where are the new positions assigned to retreating enemy artillery units in each brigade sector?
- d. Where are the new positions assigned to retreating enemy logistical units in each brigade sector?
11. How soon will units in the enemy's second echelon begin to enter each brigade's AO?
- a. What is the current known location of units comprising the enemy's second echelon in each brigade sector?
- b. What is the current rumored location of units comprising the enemy's second echelon in each brigade sector?

Figure B-2. Sample overall objective statement (IEW tasks) (continued).

FM 34-52

- c. What is the known rate of travel for units comprising the enemy's second echelon in each brigade sector?
 - d. What is the rumored rate of travel for units comprising the enemy's second echelon in each brigade sector?
12. By what routes will enemy reinforcements arrive?
- a. What is the current known location of personnel and equipment replacements for specific enemy units in each brigade sector?
 - b. What is the current rumored location of personnel and equipment replacements for specific enemy units in each brigade sector?
 - c. What are the known movement routes of personnel and equipment replacements for specific enemy units in each brigade sector?
 - d. What are the rumored movement routes of personnel and equipment replacements for specific enemy units in each brigade sector?
13. Where are the enemy's supply points located?
- a. Where are the enemy's ammunition supply points located in each brigade sector?
 - b. Where are the enemy's POL supply points located in each brigade sector?
14. What are the enemy's main supply routes?
- a. What are the known movement routes used by enemy supply convoys in each brigade sector?
 - b. What movement routes are rumored to be used by enemy supply convoys in each of the brigade sectors?
 - c. What is the known direction of travel for enemy supply convoys passing NAIs in each brigade sector?
 - d. What direction of travel is rumored for enemy supply convoys passing NAIs in each brigade sector?
15. What choke points has the enemy identified along his own LOCs?
- a. Where are choke points along the enemy's LOCs in each brigade sector known to exist?
 - b. Where are choke points rumored to exist along the enemy's LOCs in each brigade sector?
- III. INTELLIGENCE PREPARATION OF THE BATTLEFIELD.**
1. Are NBC weapons present in any of the brigade sectors?
- a. Have any noncommunications emitters normally associated with NBC weapons been identified in any brigade sector?
 - b. What is the circular area in each brigade sector within which these noncommunications emitters are probably located?

Figure B-2. Sample overall objective statement (IEW tasks) (continued).

B-26

- c. What is the nomenclature or operating frequency of the noncommunications emitters identified in each brigade sector?
2. Where will these NBC weapons be used?
- a. Have specific areas within any brigade sector been identified as targets for NBC weapons?
- b. Have orders been received by any enemy units in any brigade sector which indicate NBC weapons might be used in support of their activities?
3. What types of systems will be used to deliver these NBC weapons?
- a. What noncommunications emitters associated with very heavy artillery have been identified within each brigade sector?
- b. What noncommunications emitters associated with TELs have been identified in each brigade sector?
- c. What is the nomenclature or operating frequency of any noncommunications emitters identified in each brigade sector?
4. When will the enemy attack?
- a. What rumors indicating future offensive operations are circulating within enemy units in each brigade sector?
- b. Is the enemy massing mechanized infantry units in any of the brigade sectors?
- c. Is the enemy massing armor units in any of the brigade sectors?
- d. Is the enemy massing artillery units in any of the brigade sectors?
- e. What is the nomenclature or operating frequency of any electronic emitters belonging to enemy units preparing to conduct offensive operations in each brigade sector?
5. Where will the enemy attack?
- a. What avenues of approach will be used by specific enemy units within each brigade sector?
- b. Where are the enemy's large concentrations of mechanized infantry units within each brigade sector?
- c. Where are the enemy's large concentrations of armor units within each brigade sector?
- d. Where are the enemy's large concentrations of artillery units within each brigade sector?
- e. What is the nomenclature or operating frequency of any electronic emitters belonging to enemy units preparing to conduct offensive operations in each brigade sector?
6. What units have been assigned to conduct the attack?
- a. What enemy units are rumored to be preparing for offensive operations within any of the brigade sectors?

Figure B-2. Sample overall objective statement (IEW tasks) (continued).

FM 34-52

- b. What enemy units have been assigned to use specific avenues of approach within each brigade sector?
 - c. What is the nomenclature or operating frequency of any electronic emitters belonging to enemy units preparing to conduct offensive operations in each brigade sector?
7. What artillery groups, regimental or divisional, have been assigned to support the attack?
- a. What artillery units have been ordered to support the enemy regiments or divisions assigned to conduct offensive operations in each of the brigade sectors?
 - b. What is the nomenclature or operating frequency of noncommunications emitters belonging to the regimental or divisional artillery groups identified within each of the brigade sectors?
 - c. What is the nomenclature or operating frequency of communications emitters belonging to the regimental or divisional artillery groups identified within each of the brigade sectors?
8. Where will the enemy establish lines of defense?
- a. Where are enemy units preparing extensive field fortifications within each brigade sector?
 - b. Where are alternate artillery positions being prepared within each brigade sector?
9. What enemy units have been assigned to each defensive belt?
- a. What specific enemy units are preparing extensive field fortifications within each brigade sector?
 - b. What specific enemy units within each brigade sector are preparing alternate artillery positions?
 - c. What is the nomenclature or operating frequency of electronic emitters belonging to enemy units establishing lines of defense within each brigade sector?
10. What units comprise the reaction force to counter friendly armor or airborne assaults?
- a. What enemy units are rumored to be the reaction force for defensive positions in each brigade sector?
 - b. What enemy units are located behind, but in proximity to, the defensive positions in each brigade sector?
 - c. What is the nomenclature or operating frequency of electronic emitters belonging to the units which are part of the enemy's reaction force within each brigade sector?
11. What types of artillery are assigned to support the defense?
- a. What artillery units are rumored to be supporting the enemy's defensive positions in each brigade sector?

Figure B-2. Sample overall objective statement (IEW tasks) (continued).

B-28

- b. What is the current location of the enemy artillery units rumored to be supporting the defensive positions in each brigade sector?
- c. What is the nomenclature or operating frequency of electronic emitters belonging to the artillery units rumored to be supporting the enemy's defensive positions in each brigade sector?
- 12. What enemy units will take part in a retreat?
 - a. What enemy units in each brigade sector are rumored to be participating in a retreat?
 - b. What enemy units in each brigade sector have been notified their--
 - (1) Artillery support is moving to the rear?
 - (2) Logistical support is moving to the rear?
 - c. What is the nomenclature and operating frequency of electronic emitters belonging to retreating enemy units in each brigade sector?
- 13. What are current positions of retreating units?
 - a. What is the current location of enemy units in each brigade sector rumored to be participating in a retreat?
 - b. What is the current location of artillery units supporting enemy units in each brigade sector?
 - c. What is the current location of logistical units supporting enemy units in each brigade sector?
- 14. When will each of the retreating units begin its movement?
 - a. At what time have specific enemy units in each brigade sector been ordered to begin their retreat?
 - b. What start times are being mentioned in rumors about the retreat of specific enemy units in each brigade sector?
- 15. What routes will be taken by the retreating units?
 - a. What movement routes are being cited in rumors about the retreat of specific enemy units in each brigade sector?
 - b. What movement routes are being used or planned for use during the retreat of enemy artillery units in each brigade sector?
 - c. What movement routes are being used or planned for use during the retreat of enemy logistical units in each brigade sector?
- 16. Where will each of the retreating units establish new positions?
 - a. Where are the new positions being cited in rumors about the retreat of enemy units in each brigade sector?
 - b. Where are the new positions assigned to retreating enemy artillery units in each brigade sector?

Figure B-2. Sample overall objective statement (IEW tasks) (continued).

FM 34-52

- c. Where are the new positions assigned to retreating enemy logistical units in each brigade sector?
17. What units comprise the enemy's second echelon?
- a. What specific units are rumored to be part of the enemy's second echelon in each brigade sector?
- b. How many units comprise the enemy's second echelon in each brigade sector?
- c. What type of units comprise the enemy's second echelon in each brigade sector?
- d. What is the nomenclature and operating frequency of electronic emitters belonging to units in the enemy's second echelon in each brigade sector?
18. What is the direction of travel for each unit in the enemy's second echelon?
- a. What is the rumored direction of travel for units comprising the enemy's second echelon in each brigade sector?
- b. What are the rumored movement routes for units comprising the enemy's second echelon in each brigade sector?
19. How soon will units in the enemy's second echelon begin to enter each brigade's AO?
- a. What is the current rumored location of units comprising the enemy's second echelon in each brigade sector?
- b. What is the rumored rate of travel for units comprising the enemy's second echelon in each brigade sector?
20. How soon will enemy reinforcements arrive?
- a. What times are being cited in rumors about the arrival of personnel replacements at specific enemy units in each brigade sector?
- b. What times are being cited in rumors about the arrival of equipment replacements at specific enemy units in each brigade sector?
21. By what routes will enemy reinforcements arrive?
- a. What are the current locations of replacement personnel and equipment cited in rumors about specific enemy units in each brigade sector?
- b. What are the movement routes of replacement personnel and equipment cited in rumors about specific enemy units in each brigade sector?
22. What specific enemy units are serviced by enemy supply points?
- a. What ammunition supply points support specific enemy units in each brigade sector?
- b. What POL supply points support specific enemy units in each brigade sector?
- c. What is the nomenclature or operating frequency of electronic emitters belonging to enemy supply points in each brigade sector?

Figure B-2. Sample overall objective statement (IEW tasks) (continued).

23. What malfunctions are occurring with enemy communications?
- a. What malfunctions are occurring with enemy vehicle-mounted communications equipment in each brigade sector?
 - b. What malfunctions are occurring with enemy manpacked communications equipment in each brigade sector?
 - c. What is the nomenclature or operating frequency of enemy communications equipment which is malfunctioning?
24. What are major enemy supply routes?
- a. What are the known movement routes used by enemy supply convoys in each brigade sector?
 - b. What movement routes are rumored to be used by enemy supply convoys in each of the brigade sectors?
 - c. What is the known direction of travel for enemy supply convoys passing NAIs in each brigade sector?
 - d. What direction of travel is rumored for enemy supply convoys passing NAIs in each brigade sector?
25. What choke points have the enemy identified along their own LOCs?
- a. What choke points along enemy LOCs in each brigade sector are known to exist?
 - b. What choke points are rumored to exist along enemy LOCs in each brigade sector?
- IV. FORCE PROTECTION.**
1. Where will NBC weapons be used?
 - a. Have specific areas within any brigade sector been identified as targets for NBC weapons?
 - b. Have orders been received by any enemy units in any brigade sector which indicate that NBC weapons might be used in support?
 - c. Where has enemy air activity suddenly increased within any of the brigade sectors?
 - d. Where is unusual enemy air activity taking place within any of the brigade sectors?
 - e. Where has very heavy artillery been moved to within supporting distance of front-line enemy troops within any brigade sector?
 - f. Where has random firing of very heavy artillery occurred within any of the brigade sectors?
 2. What is the main objective of enemy attack?
 - a. What objectives have been assigned to specific enemy units in each brigade sector for their offensive operations?

Figure B-2. Sample overall objective statement (IEW tasks) (continued).

FM 34-52

- b. How many enemy units within each brigade sector have been assigned the same objectives?
- c. What measures are the enemy using to conceal the offensive's objectives in each brigade sector?
- 3. What units have been assigned to conduct the attack?
 - a. What enemy units are rumored to be preparing for offensive operations within any of the brigade sectors?
 - b. What special operations elements are attached to enemy units preparing for offensive operations in each brigade sector?
 - c. What is the nomenclature or operating frequency of any electronic emitters belonging to enemy units preparing to conduct offensive operations in each brigade sector?
- 4. What enemy units have been assigned to defensive belts?
 - a. What specific enemy units are preparing extensive field fortifications in each brigade sector?
 - b. What special operations elements have been attached to enemy units establishing lines of defense in each brigade sector?
 - c. What is the nomenclature or operating frequency of electronic emitters belonging to enemy units establishing lines of defense within each brigade sector?
 - d. What measures are employed to conceal defensive preparations in each brigade sector?
- 5. What units comprise the reaction force to counter friendly armor or heliborne assaults?
 - a. What enemy units are rumored to be the reaction force for defensive positions in each brigade sector?
 - b. What enemy units are located behind, but in proximity to, the defensive positions in each brigade sector?
 - c. What special operations elements have been attached to the units in enemy reaction force in each brigade sector?
 - d. What is the nomenclature or operating frequency of electronic emitters belonging to the units which are part of the enemy's reaction force within each brigade sector?
- 6. What enemy units will take part in a retreat?
 - a. What enemy units in each brigade sector are rumored to be participating in a retreat?
 - b. What special operations elements are attached to retreating enemy units in each brigade sector?
 - c. What enemy units in each brigade sector have been designated as stay-behind elements?

Figure B-2. Sample overall objective statement (IEW tasks) (continued).

B-32

- d. What efforts have been made to recruit stay-behind agents from the local populace in each brigade sector?
 - e. What is the nomenclature or operating frequency of electronic emitters belonging to retreating enemy units in each brigade sector?
7. What deception efforts will be made to conceal the retreat?
- a. What deception efforts have been ordered in conjunction with the retreat in each brigade sector?
 - b. What specific enemy units are conducting deception efforts in conjunction with the retreat in each brigade sector?
 - c. What special operations elements are involved in the deception efforts being conducted in each brigade sector?
 - d. What deception efforts are being cited in rumors about the retreat in each brigade sector?
 - e. What enemy units are rumored to be conducting deception efforts in conjunction with the retreat in each brigade sector?
8. What units comprise the enemy's second echelon?
- a. What specific units are rumored to be part of the enemy's second echelon in each brigade sector?
 - b. How many units comprise the enemy's second echelon in each brigade sector?
 - c. What type of units comprise the enemy's second echelon in each brigade sector?
 - d. What special operations elements are attached to units in the enemy's second echelon?
 - e. What is the nomenclature and operating frequency of electronic emitters belonging to units in the enemy's second echelon in each brigade sector?
- V. BATTLE DAMAGE ASSESSMENT.
1. What production loss has the enemy sustained?
- a. How long will it take to recuperate?
 - b. What was the extent of battle damage?
 - c. What was the attack's total effect?
 - d. How much warfighting stock was lost?
 - e. How many personnel were lost?
 - f. What type, and how many pieces, of warfighting equipment were destroyed or damaged?

Figure B-2. Sample overall objective statement (IEW tasks) (continued).

FM 34-52

- g. How many craters are visible?
 - h. Where was the detonation point?
 - i. What contingency plans have been put into effect?
- VI. INDICATIONS AND WARNING.
- 1. How stable is the current government?
 - a. What anti-allied demonstrations are planned?
 - b. Who, or what organization, is responsible for the unrest?
 - c. How well financed is the opposition?
 - d. What outside help is the opposition receiving?
 - e. What is the current economic situation?
 - f. What kind of treatment can foreign citizens expect?

Figure B-2. Sample overall objective statement (IEW tasks) (continued).

B-34

APPENDIX C

S2 TACTICAL QUESTIONING GUIDE AND BATTLEFIELD EXPLOITATION OF CAPTURED ENEMY DOCUMENTS AND EQUIPMENT

History shows that EPWs, CEDs, and CEE are critical sources of combat intelligence. It has also shown the usefulness of information is directly proportionate to how fast a commander can get it.

OPERATIONS URGENT FURY, JUST CAUSE, and DESERT STORM proved that without workable procedures to handle captured persons or items, our combat effectiveness suffers because the evacuation chain jams the forward resupply effort. We also suffer because we have not exploited combat information

sources at a low enough echelon to do that commander any good.

This guide is for battalion and brigade S2s. It explains standard procedures on what to do when the S2—

- Receives an enemy soldier.
- Detains a civilian.
- Finds an enemy document.
- Discovers an unusual enemy weapon during tactical operations.

PERSONNEL HANDLING

There are two types of persons captured on the battlefield: combatants and noncombatants. FM 27-10 defines the two types. The capturing unit treats all combatants and noncombatants as EPWs until the division forward collecting point segregates them by category. This is whether they are soldiers, clergy, or medics (see Chapter 3).

Noncombatants are handled, questioned, detained, evacuated, and released in accordance with theater policy.

At the EPW's capture point, the capturing element performs the following steps, with the senior soldier responsible for ensuring they are done. The steps are referred to as the "five S's."

STEP 1. SEARCH

The POC unit's first job is to disarm, then search all EPW or detainees, and tie their hands behind their back. They gather all loose enemy documents and equipment in the area. They evacuate them with the EPW. Documents and personal and protective military equipment stay with the prisoner unless otherwise directed by the battalion S2.

STEP 2. SILENT

The capturing unit instructs or signals EPWs to be silent. If that does not work, the EPW is gagged. Guards give orders to EPWs, but do not talk nor give them comfort items.

STEP 3. SAFEGUARD

The POC unit immediately moves the EPWs out of the fire zone. They protect EPWs from reprisals and give them medical care as necessary. The POC unit tries to preserve the shock of capture until brigade interrogators have a chance to question the EPWs.

STEP 4. SEGREGATE

The POC unit orders the EPWs to sit on the ground. It separates officers from enlisted, senior from junior, male from female, and civilian from soldier. It prepares a captive tag and puts one on each EPW (Figure 3-4). Tagging procedures are discussed under equipment handling procedures below.

STEP 5. SPEED TO THE REAR

Lastly, the POC unit moves EPWs to the unit supply point for evacuation. All captured documents, personal effects, and portable enemy equipment go with the EPW. Also, one escort guard should know the EPW's circumstances of capture.

FM 34-52

CAPTURED ENEMY DOCUMENTS FOUND ON ENEMY PRISONER OF WAR

The battalion S2, and subordinate unit commander, ensures CEDs found on EPWs are handled as follows. The POC unit will—

- Search each EPW.
- Return identification documents to EPW.
- Write the following on the top and bottom half of the EPW captive tag: Number of documents taken; date and time, location and circumstances of capture; capturing unit's designation.
- Put CED in a waterproof bag, one per EPW.
- Affix Part C of the captive tag to the bag (see Figure 3-4).
- Give CEDs to senior escort.
- Direct senior escort to evacuate CEDs with the EPW.

CAPTURED ENEMY DOCUMENTS FOUND ON THE BATTLEFIELD

An example of CEDs found on the battlefield is paperwork discovered in an overrun CP, but not on an EPW's person. The POC unit will—

- Put CEDs in a waterproof bag.
- Follow the same procedures described above, and tag the bag.
- Evacuate to battalion S2.
- Battalion S2 evacuates all CEDs along EPW evacuation channels.

EQUIPMENT HANDLING PROCEDURES

CEE includes all types of foreign materiel found on an EPW or on the battlefield that may have military application. The POC unit—

- Evacuates equipment with the EPW.
- Confiscates, tags, and evacuates weapons and other equipment found on an EPW the same as CEDs.

ITEMS OF TECHINT VALUE

The capturing unit may recognize certain CEE as having possible TECHINT value. Such items include—

- New weapons.
- Radios.
- Track vehicles.
- Associated manuals.
- All CEE known or believed to be of TECHINT interest.

The capturing unit's primary job when capturing a TECHINT item is to secure and report the capture to its S2 for disposition instructions. Figure C-1 provides a scenario for TECHINT items.

**FIRST ECHELON BATTLEFIELD
TECHINT EXPLOITATION**

It is conceivable, although not likely, that the capturing unit leader or S2 may need to do field exploitation of a piece of CEE. If this happens—

- It will usually be at the request of the battlefield TECHINT team attached to corps headquarters.
- The small-unit leader or S2 follows the same procedures used to exploit a CED.

TAGGING PROCEDURES

There are two capture tags: A CEE tag and an EPW tag with a smaller tear-off document tag. The POC unit tags all captured personnel, CEDs, and CEE at the POC.

The battalion S2 or company commander is responsible for having sufficient CEE and EPW document tags as well as and waterproof bags prior to an operation.

When no standard tag forms are available, the following procedures will be used for expediency:

- Use meals, ready-to-eat (MRE) cardboard or other type of paper.

C-2

FROM THE FOXHOLE TO THE CMEC

The soldier either captures or observes an item of possible TECHINT interest. The soldier quickly reports the encounter through his or her command to the Battalion S2. The soldier then either safeguards the item or continues the mission as directed.

Upon learning that a forward platoon or company has captured or encountered an item of possible TECHINT interest, the Battalion S2 promptly—

- Coordinates security or continued observation of the item with the S3 and ensures the item is not tampered with in any way. Components, control knobs, and switches on C-E equipment should not be touched until the equipment is photographed or positions recorded.
- Examines and screens the item against PIR and IR and determines whether the item is known or believed to be of TECHINT interest; or, whether, in the soldier's opinion, the item deserves initiative reporting.
- Spot reports the capture or encounter in the SALUTE format through higher headquarters to the first Battlefield TECHINT element in the chain of command.
- Coordinates continued security or observation of the item until receipt of further instructions.
- Identifies items requiring immediate screening for combat information by other supporting MI elements. This could include C-E system items like code books, radios, or technical documents such as operator manuals.

Intermediate echelons of command continue forwarding the spot reported encounter or capture to their supporting Battlefield TECHINT element.

The supporting Battlefield TECHINT element receives the spot report and compares the information to requirements and the existing data base to see if collection is necessary. The element then decides further action and notifies the capturing unit accordingly. The CMEC or Battlefield TECHINT team's options at this point include, but are not limited to—

- Requesting the capturing unit to provide further information, such as detailed descriptions, sketches, photographs, or documents captured with the item.
- On-site screening or exploiting.
- Destroying the item.
- Abandoning the item unharmed.
- TECHINT team-supervised or routine evacuating.
- Priority evacuating to EAC.
- Recommending turning over initial exploitation to other MI elements, such as target exploitation or interrogators, for immediate tactical information screening.

Figure C-1. Disposition of TECHINT items scenario.

FM 34-52

- Write the capturing unit's designation.
- Write date and time of capture.
- Write POC coordinates.
- Write circumstances of capture.
- Identify EPW, CED, or CEE captured.
- Put tag, without damaging the CED, in a waterproof bag.
- Attach EPW and CEE tags so they will not come off.

TACTICAL QUESTIONING

This section provides "how to" instructions to enable the S2 to do tactical questioning (TQ) on EPWs. Following these will—

- Achieve usable results.
- Preserve the source for subsequent formal interrogation.
- Keep the S2 from breaking the law.

WARNING

Improper, unlawful, or inept attempt at field exploitation can harm or destroy possible critical intelligence sources, and send US soldiers to prison. Any decision to attempt these procedures is a command responsibility, and only done by the S2.

Figure C-2 is an example of the front and reverse sides of a CEE tag. It should be included as a tab to the TECHINT appendix in the intelligence annex of an OPLAN plan or operations order (OPORD).

The purpose of TQ is to obtain combat information of immediate use to the battalion or subordinate unit by the S2. Sources of information can be an EPW and local or friendly civilians encountered in the operational area. (S2s use established procedures when questioning local or friendly civilians.)

LANGUAGE REQUIREMENT

TQ can be done only under one of following circumstances:

- The S2 speaks the EPW's language well enough to ask direct questions and understand the answers.

- A language qualified interpreter is available to assist the S2.

WHERE TQ IS DONE

TQ is done as soon as possible after removing the EPW from fire zones. However, battalion or brigade commanders forced to deal with heavy EPW input may set up an organized TQ effort at the unit's EPW collecting point.

WHO ASKS THE QUESTIONS

Only the S2 is authorized to conduct TQ. The S2 asks every question himself, even when using another soldier or local national as an interpreter. If augmented by interrogators, the interrogation team supervises the TQ effort.

TIME CONSIDERATIONS

TQ is designed to be a quick procedure, lasting from 5 to 20 minutes. A command decision is required if source questioning interferes with mission accomplishment or delays a priority evacuation.

ITEMS NEEDED FOR TQ

TQ is authorized for collection of combat information critical to successful mission accomplishment. The questioner needs to know what information headquarters requires. Other items required for TQ are—

- Maps.
- Vehicle and aircraft identification guides.
- Target language dictionary.
- Report forms, stationery, capture tags, waterproof bags.
- Interpreter or translator.

THE EXPLOITATION PROCESS

The exploitation process, discussed in Chapter 3, is the basis for all personnel examinations, to include TQ.

It consists of three parts: screening, questioning, and reporting.



 TO BE AFFIXED TO CAPTURED ENEMY EQUIPMENT DO NOT DISTURB NOMENCLATURE: <u>MT-140-A</u> SERIAL NO: <u>1234567</u> DATE/PLACE CAPTURED: <u>2 FEB 99</u> <u>CA 123456</u> CAPTURING UNIT: <u>2 INF Co/2/3 REGT</u> QUANTITY: <u>ONE EACH</u>	 TECH INTEL USE ONLY TIME OF RECEIPT: _____ DATE OF RECEIPT: _____ INSPECTED BY: _____ <small>NAME NAME</small> DISPOSITION: _____ _____ _____
BELOW FOR USE BY TECH INTEL UNITS ONLY	
PROPERTY U.S. GOVERNMENT NOTICE THIS EQUIPMENT IS BEING HELD FOR: ANALYSIS UTILIZATION DESTRUCTION BY AUTHORITY OF THE JOINT U.S. FORCES COMMANDER. SIGNATURE _____ PRINTED NAME _____ UNIT _____ DATE _____	PROPERTY U.S. GOVERNMENT DO NOT DISTURB THIS EQUIPMENT PROPERTY U.S. GOVERNMENT PERSONNEL TAMPERING WITH THIS EQUIPMENT WILL BE SUBJECT TO PROSECUTION UNDER ARTICLE 103, UCMJ
DO NOT DISTURB	

Figure C-2. Front and reverse sides of CEE tag.

FM 34-52

SCREENING

If there is more than one EPW, the quickest method to pick who to question first is to—

- Check the captive tag to see if your unit recently captured the EPW with unusual equipment; for example, a sniper rifle or booby trap in an area of operational interest.
- Observe for high rank, key enemy unit patches, and unusual behavior.
- Use established guidelines and rank the most likely EPWs first for questioning.

QUESTIONING

The key to questioning is brevity. Tactical questioners work fast until they find an EPW who will give useful combat information. To do this, the tactical questioner—

- Ensures the EPW is under guard.
- Briefs interpreter as necessary.
- Has the EPW searched and obtains identity document.
- Looks over EPW's identity document and CEDs.
- Makes a mental questioning plan.
- Presents military bearing. Preserves the shock of capture.
- Asks military questions, intermixing biographical questions so as not to arouse the EPW's security training.
- Compares answers given on the identity card and other items found on the EPW to check for truthfulness.
- Ends questioning if the EPW stops or refuses to answer military questions.
- Ends questioning if the EPW intentionally or unintentionally provides so much irrelevant military in-

formation instead of information pertinent to the tactical questioner's combat mission.

- Never promises anything that cannot be delivered.

REPORTING

Tactical questioners report acquired information in SALUTE format (Figure 3-5). To do this, they—

- Obtain combat information using the direct questioning technique (see Chapter 3).
- Record combat information of interest to headquarters. This is recorded in SALUTE format as relevant answers are obtained.
- Attempt to fill in all SALUTE report blanks before moving to another collection requirement or before ending the questioning.
- End questioning by telling the EPW they will talk again, and return required items, such as the EPW's ID.

THE TACTICAL QUESTIONING PLAN

The questioning plan used during TQ is short, simple, and standard. The questioner can use it to uncover spot reportable information on any subject. An easy way to remember it is through the phrase "BIG 4 and JUMP."

- BIG 4 is a nickname for the Geneva Convention's "name, rank, service number, and date of birth."
- JUMP is an acronym for job, unit, mission, PIR, IR, and SIR, which is the sequence of the TQ plan.

More specifically, the TQ plan covers the following topics in sequence. Figure C-3 shows examples of the BIG 4 and JUMP questions.

- EPW biographical data.
- EPW duty position or job.
- EPW unit or employer.
- EPW present and future mission at time of capture.
- Commander's collection requirements in order of priority.

BATTLEFIELD DOCUMENT EXPLOITATION

Battlefield DOCEX is a capturing unit procedure done by the S2 before interrogator exploitation. A combat unit without language-qualified personnel can perform limited battlefield DOCEX, mainly on maps and

overlays. Units with linguists have the advantage of being able to do more.

C-6

What is your last name? First name? Middle name?
 What is your rank? Service number? Date of Birth?

* * * *

What is your position (or job) in your unit (or firm)?
 What unit are you in (or who do you work for)?
 What was your mission (or what type of work were you doing) when you were captured?
 What would your future mission have been (or what jobs or projects would you have had) had you not been captured? What other missions would you have had if you had not been captured?

* * * *

Follow up on all given information items; in particular, ensure you have the source's full unit designation and thoroughly follow up on the source's missions. A good rule of thumb is to ask Who, What, When, Where, How, and Why to fully develop whatever information you obtain.

NOTE: Continue to ask questions based on collection requirements, phrasing them as direct questions. For example, "Where is the GATO cell's arm caches?" or "When will your unit attack SAN PABLO?"

Figure C-3. BIG 4 and JUMP question examples.

After capturing an EPW or enemy CP, the capturing unit needs to look for maps, encrypted items, OPORDs, overlays, and other documents. The capturing unit then notifies headquarters to request disposition instructions.

The small-unit leader safeguards the items pending disposition instructions. At the same time he—

- Looks over the document.
- Does not mark or harm it in any way.

- Uses whatever resources are available to decipher it; for example, dictionaries and enemy map symbol guides. An example of Soviet and non-NATO symbols is at Figure C-5.

- Looks for information that has a direct bearing on his current mission.

After finding information of possible value to the mission, the S2 extracts the combat information and uses the SALUTE format as a template to organize the information (see Figure 3-5).

FM 34-52

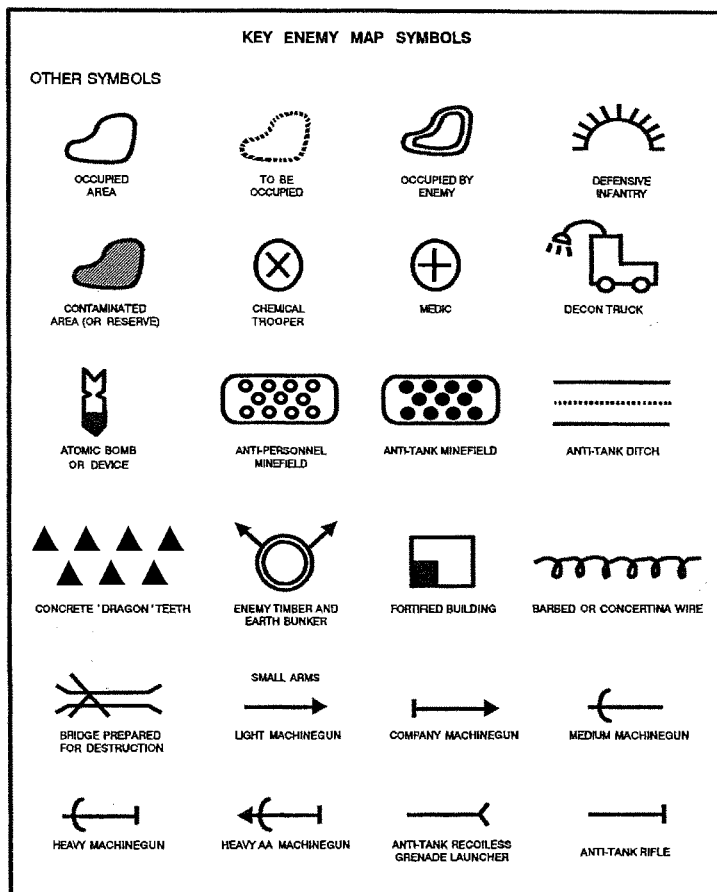

Figure C-4. Soviet and non-NATO map symbols.

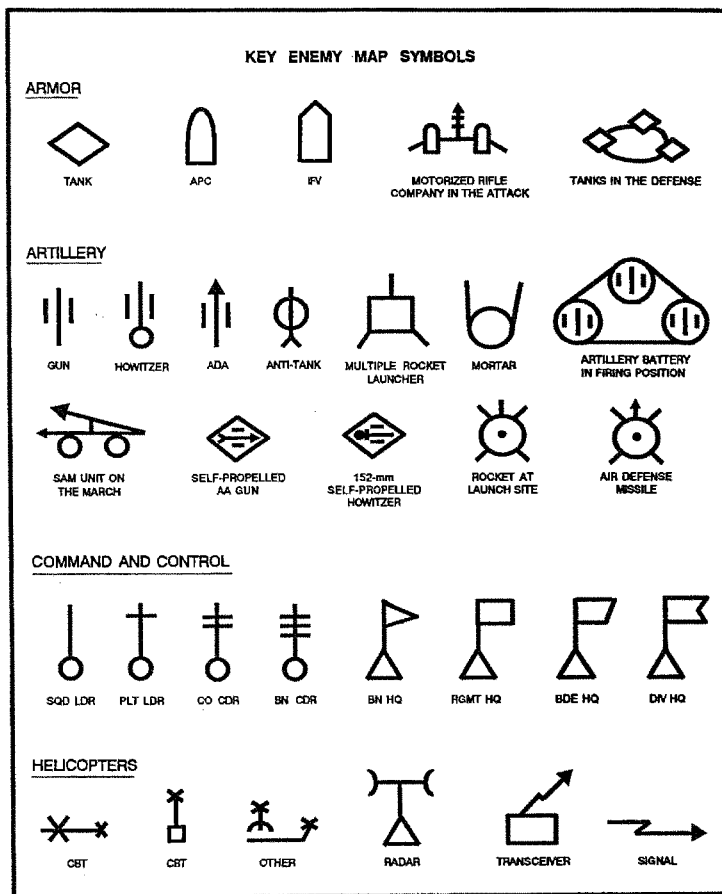

Figure C-4. Soviet and non-NATO map symbols (continued).

APPENDIX D

PROTECTED PERSONS RIGHTS VERSUS SECURITY NEEDS

The articles in this Appendix are extracted from the Geneva Convention Relative to the Protection of Civilian Persons in Time of War of August 12, 1949.

The GC attempts to balance the necessity of the proper treatment of protected persons with the needs of security by the Detaining or Occupying Power. The GC applies to the whole of the populations of the countries in conflict, without any adverse distinction based, in particular, on race, nationality, religion, or political opinion. It is the design of the Convention to alleviate the sufferings caused by war (Article 13).

At the outbreak of a conflict, many protected persons become displaced persons. They move within their own country to areas where hostilities are not a threat or a power is able to protect them. They may become refugees, fleeing into neighboring countries seeking a safe haven. The GC provides that protected persons who desire to leave at the outset of, or during a conflict, should be allowed to do so, unless their departure is contrary to the national interest of the State (Article 35). However, in light of possible threats to the security of the State receiving the refugees or a Detaining Power, the Geneva Convention does recognize a State's right to take appropriate action to insure security.

The most typical security measure taken in such cases is the establishment of some manner of screening camps where the people may be identified and screened. During the process, useful intelligence may be obtained from legitimate displaced persons or refugees, and from potential threats, such as covert agents, who may be identified and interrogated.

In most cases, interrogators or linguists will conduct the screening operations while working closely with CI personnel to identify those protected persons of CI interest. Other military intelligence personnel may be required to participate in this screening process because of the large numbers of refugees and/or the lack of other qualified personnel.

Internment of a protected person occurs when the Detaining Power determines that confinement or assignment of residences to certain protected persons is absolutely necessary to the security of the Detaining Power (Articles 41 and 42). A civilian internee is defined by the Department of Defense (DOD) as a civilian who is interned during an armed conflict or occupation for security reasons or for protection or because he has committed an offense against the Detaining Power.

GENEVA CONVENTION PROVISIONS CONCERNING PROTECTED PERSONS

It is critical that the GC provisions concerning protected persons be strictly adhered to in the quest to identify legitimate threats and gain needed intelligence. Specifically:

(a) Article 5 provides that if a Party to the conflict is satisfied that an individual protected person is suspected of or engaged in activities hostile to the security of the State, such individual shall not be entitled to claim rights or privileges under the convention, if the exercise of that right would be prejudicial to that State. However, such individuals must be humanely treated during internment and the pendency of any investigation and/or prosecution. A limitation of rights or privileges may include the withholding of the right to communicate with members of their family or representatives of their government. Such restrictions would be appropriate in a case involving spying.

(b) Article 29 places the responsibility for the treatment accorded protected persons upon the Party in whose hands they are found. This is in addition to any personal responsibility incurred by an agent of that Party. This is an affirmative duty upon commanders to insure their subordinates are not mistreating protected persons or their property. The command and the government will ultimately be held responsible for any mistreatment.

(c) Article 31 prohibits physical or moral coercion against protected persons to obtain information from them or from third parties. Prohibited coercion may be obvious, such as physically abusing the subject of the screening or interrogation. It may also be more subtle, such as threats to turn the individual over to hostile forces; subjecting the individual to humiliating or degrading treatment; implying harm to the individual or his

FM 34-52

property, or implying a deprivation of rights guaranteed by international law because of a failure to cooperate; threatening to separate parents from their children; or forcing a protected person to perform guide services.

(d) Article 32 prohibits corporal punishment, torture or taking any measure of such character as to cause the physical suffering or extermination of protected persons in your control. This prohibition not only applies to actions taken by the Detaining Party against the protected persons, but also any adverse action that others may take.

(e) Article 33 prohibits collective punishments, penalties, reprisals, or pillaging of protected persons and their property. The principle behind this provision is that protected persons should only be held liable for offenses they personally commit. This prohibition includes all measures of intimidation or terrorism.

(f) Article 41 allows the Power, in whose hands the protected persons are found, to intern or force assigned residence to protected persons, if the other measures of control permitted by the convention are inadequate. Some persons may demand internment (for example, protected persons who may be threatened by others). Internment must be provided when the situation renders this step necessary (Article 42).

(g) If interned or forced into assigned residences, protected persons have the right to have any such determination reconsidered and reviewed on a periodic basis (Article 43).

(h) In connection with the above, Article 44 prohibits the Detaining Power from automatically interning or forcing an assigned residence against refugees who are nationals of an Enemy State, exclusively on the basis of their nationality, who do not, in fact, enjoy the protection of any government. The purpose of this article is to insure that refugees, who may only technically remain enemy aliens, are not, on that basis alone, automatically subject to control measures, notwithstanding the fact that they are not protected by their government. An example of this would be interning Iraqi refugees based solely on their status as Iraqis. This prohibition, however, does not in any way deny the right of a State to intern such persons or subject them to legitimate controls when there is an additional basis for taking such action in the interest of security of the State.

(i) Article 45 prohibits the transfer of protected persons into the custody of a Power not a signatory to the convention. The transferring Power must insure that protected persons transferred from their custody will be treated in accordance with the conventions. In the event that the transferring Power discovers that the protected persons are not being treated in accordance with the convention, they shall request that the protected persons be returned to their custody.

APPENDIX E

REPORTS

In addition to reports previously covered, there are other reports prepared or used by interrogators in tactical and strategic units. DIAM 58-13 is the authority for format and preparation of intelligence information reports (IIRs), biographic reports, and knowledgeability briefs (KBs). Local SOPs guide the interrogator in preparing other reports.

Message Text Format (MTF) Editor is software used by the military services, National Security Agency (NSA), and Defense Intelligence Agency (DIA).

MTF Editor—

- Creates, formats, edits, stores, prints, and transmits United States Message Text Formatting (USMTF) messages.
- Is designed to run on Z-150, AN/UYK-83, Z-248, IBM PC compatibles, and other standard and non-standard systems.
- Requires minimum 320K random access memory (RAM), microsoft (MS) or personal computer (PC) disk operating system (DOS) version 2.1 or higher, and 5.25-inch disk drive.

- Is "user friendly," as it employs many of the same commands available in commercial word processors.

The SALUTE report format contains relevant information necessary to alert higher commands of an incident or relevant information obtained. It answers all basic interrogatives: Who, What, When, Where, How, and Why.

Figures of sample reports, formats, and tags used by interrogators are listed below:

- Figure E-1, Spot report voice message template.
- Figure E-2, Battlefield TECHINT spot report.
- Figure E-3, Tactical interrogation report.
- Figure E-4, Captive tag (STANAG 2044).
- Figure E-5, IIR.
- Figure E-6, Biographic report.
- Figure E-7, Knowledgeability brief.
- Figure E-8, Interrogation report.

TACTICAL INTERROGATION REPORT

The TIR (Figure E-3) serves as written summary of initial or subsequent interrogations. The term "tactical interrogation report" was adopted under NATO STANAG 2033. The TIR—

- Eliminates information duplication of effort in later EPW interrogations.
- Disseminates information to the intelligence officers of the immediate command, those of other appropriate commands, and interrogators who will conduct further interrogations.
- Serves as an intelligence value assessment of EPWs, documents, and equipment carried by him at time of capture.
- Consists of Part I, Intelligence Potential of EPW, and Part II, information obtained.

In the heading, the EPW will be classified according to one of four categories explained in Chapter 4 under document exploitation.

The first section of the report contains the source's name and category, interrogation serial number, date, report number, interrogator's name and unit, maps and language used, and interpreter's name (if one is used).

The second section, Part I, contains the EPW's personal particulars, career, assessment of intelligence value, capture data from the captive tag, and documents and equipment found on the EPW.

The third section, Part II, lists information obtained from the EPW during the interrogation regarding missions, composition, strength, dispositions, tactics, training, logistics, combat effectiveness, electronic technical data, and miscellaneous data.

FM 34-52

BIOGRAPHIC DATA ENTRIES

The following data prosigns are used in biographic reporting. If available, biographic information will fit in the summary of the IIR; the text entry will be NONE.

Should the reportable information exceed the limitations of the summary, entries will be made in the text. When making entries, ensure that the numbers and prosigns shown here are those used in the biographic report; if you have no data for a particular item, skip it and list the next item for which you have a data entry. Items skipped are not listed on the report.

The paragraph classification follows the biographic prosign. Do not use colons to separate the prosign and data entries. Minimum essential data (MED) prosigns are asterisked.

SUMMARY INTERROGATION REPORT

The rationale behind the summary interrogation report, shown at Figure E-8, is to preclude duplication

of effort. In DESERT STORM, as EPWs were being evacuated up the chain, the gaining interrogator would ask questions only to be told the same questions had already been asked by somebody else at a previous location. This is embarrassing, and does not foster rapport building, because the gaining interrogator had no previous EPW screening or interrogation reports. It was assumed this was the first time the EPW was questioned.

If the previous echelon received EPW information pertaining only to their immediate tactical situation, with no reports being forwarded, it would have been to the gaining interrogators advantage to be apprised of what transpired at the lower echelon; hence the summary interrogation report. This report is simple in design and purpose, but reveals EPW information that gives the gaining interrogator insight as to what was developed at the previous echelon.

VOICE MESSAGE TEMPLATE FOR A SPOT (SALUTE) REPORT	
<u>G2, X CORP</u>	<u>THIS IS G2, 25TH INF DIV SALUTE OVER</u>
addressee	originator
<u>THIS IS</u>	<u>SEND SALUTE OVER</u>
originator	addressee
<u>THIS IS</u>	<u>SALUTE PROBLEMS</u>
addressee	originator
FLASH IMMEDIATE <u>PRIORITY</u> ROUTINE	(Underline and transmit the precedence of this message.)
TOP SECRET SECRET CONFIDENTIAL	(Underline and transmit the security classification of this message.)
CLEAR <u>UNCLASSIFIED</u>	
SALUTE REPORT	
1. <u>SIZE SQUAD</u>	(Enter the size of the unit or target.)
2. <u>ACTIVITY RECON</u>	(Enter a description of the activity detected.)
3. <u>LOCATION CR 123456</u>	(Enter the target location [UTM].)
4. <u>UNIT 1 MRS/2/3/44/59 MRD</u>	(Enter the unit identity or type.)
5. <u>TIME NLT 171800Z FEB 99</u>	(Enter the time of the sighting.)
6. <u>EQUIPMENT NA</u>	(Enter the name of any equipment sighted.)
7. <u>DIRECTION NA</u>	(Enter the direction if target is moving in degrees or mils.)
8. <u>TIME 1105T</u>	(Enter hour-minute-zone. See NOTE.)
9. <u>AUTHENTICATION IS 170225</u>	(Enter message authentication. See NOTE.)
10. <u>OVER</u>	
NOTE: The message DTG is used when required to identify message time of origin. Authentication will be in accordance with joint task force procedures.	

Figure E-1. Spot report voice message template.

FM 34-52

BATTLEFIELD TECHINT SPOT REPORT	
TO:	VI CORPS TECHINT TEAM
THRU:	RS2, 14th ACR
FROM:	SS2, 3/14th ACR
DTG:	300700ZJAN99
REPORT NO:	07-0623
SIZE:	3xMissiles, 1xSuitcase, 1xControl Box with periscope sight, 1xSpent missile round.
ACTIVITY:	Capture of antitank wire-guided missile system. NATO nomenclature AT-3/SAGGER Mannpack.
LOCATION:	Capture at coordinates //32UNB538331//.
TIME:	Time of capture was 300530ZJAN99.
EQUIPMENT/HOW:	System captured intact after overrunning enemy ambush position. No associated enemy captured. Equipment secure. Awaiting disposition instructions.
REMARKS:	
SOURCE DATA:	Captured Enemy Equipment.
MAP DATA:	GERMANY, 1:50,000, LAUTERBACH, L5322, EDITION 5
MISC DATA:	REPORT NO: 07-0623

Figure E-2. Sample battlefield TECHINT spot report.

(CLASSIFICATION)	
TACTICAL INTERROGATION REPORT	
<u>NAME OF PRISONER:</u> KLEYMENOV	<u>INTERROGATOR:</u> SGT ROYCE.
<u>CATEGORY:</u> A B C D	<u>UNIT/FORMATION TO WHICH INTERROGATOR ATTACHED:</u> Intg Sec, Intel-Surv Co, 231st MI Bn, 23d Inf Div
<u>INTG SERIAL NO:</u> US-AR-1234-1	<u>MAPS USED:</u> GERMANY, 1:50,000, EISENACH HUNFELD, Ed #2.
<u>DTG OF INTG:</u> 221700ZNOV99	<u>LANGUAGE USED:</u> Russian
<u>INTG REPORT NO:</u> PT-001	<u>INTERPRETER:</u> None
PART I - INTELLIGENCE POTENTIAL OF ENEMY PRISONER OF WAR (EPW)	
A. PERSONAL PARTICULARS:	
1. Rank, full name, service number, and position: JrLT, Dimitar KLEYMENOV, No. 0506031, Plt Ldr.	
2. Date and place of birth: 23 May 72, TBILISI, Georgian SSR, USSR.	
3. Nationality: Soviet (Ethnic Rumanian) (Religion: Orthodox).	
4. Knowledge of languages and proficiency: Russian (N).	
5. Unit, formation, or organization: 2 MR Plt (MRP), 2 MR Co (MRC), 3 MR Bn (MRB), 62 MR Regt (MRR), 34 MR Div (MRD)(2MRP/2/3/62/34MRD).	
6. Date/time, place/grid references, capturing unit and circumstances of capture: 221330ZNOV99, Hill 457 (NB625305), A/1/2/3, captured after taking Hill 457.	
B. CAREER:	
1. Premilitary: Gymnasium graduate, attended 1 year at University of Moscow. Vocational training: None. Paramilitary training: None.	
2. Military: 5 years military service, attended OCS Oct97; previous military jobs: Assistant Platoon Leader.	
DOWNGRADING/DECLASSIFICATION DATA: (NOTE: This report is UNCLASSIFIED. The word "CLASSIFICATION" is used for training purposes to denote lines which may carry classification markings on an actual report.)	
(CLASSIFICATION)	

Figure E-3. Sample TIR.

FM 34-52

(CLASSIFICATION)	
C. ASSESSMENT OF INTELLIGENCE VALUE:	
1.	Intelligence, experience, cooperation, reliability: EPW seemed cooperative in that he did not hesitate to answer questions. EPW has 5 years' military experience. EPW appeared reliable in that no discrepancies were noted through the use of control and repeated questions. EPW was of average intelligence as he attended 1 year University of Moscow.
2.	Specialist knowledge: None.
3.	Discussion of approach techniques: EPW cooperated on the orchestration of the Incentive (better treatment) and Pride and Ego Up (too good to do mundane EPW work) approaches.
D. DOCUMENTS CARRIED AT TIME OF CAPTURE:	
1.	List of documents: 1xID card No. 0506031 (returned to EPW).
2.	Details of money and valuables: 18rubles (impounded and receipted).
E. EQUIPMENT OF INTELLIGENCE INTEREST CARRIED AT TIME OF CAPTURE:	
1.	Personal equipment: 1xShMK protective mask (returned to EPW).
2.	Weapons: 1x9mm PM pistol, 2xempty magazines, 1xfull magazine (all evacuated through supply channels).
PART II - INFORMATION OBTAINED	
A. SUMMARY:	
1.	DOI is 221330ZNOV99 unless otherwise indicated in the body of this report.
2.	This report contains information pertaining to the 34th MRD, or units subordinate thereto.
B. TEXT:	
1. MISSIONS:	
a. EPW:	
(1) TOC: To establish Plt OP and defensive position for 2MRP/2/3/62/34MRD.	
(2) FUTURE: To assist calling in artillery fire on enemy positions.	
(3) PAST: Participated in assault against Hill 457 (NB625305).	
b. UNIT: (2MRP/2/3/62/34MRD).	
(1) PRESENT: To establish and maintain OP and defensive positions.	
(2) FUTURE: To monitor convoy traffic, use position as jumping off point for future operations.	
(CLASSIFICATION)	

Figure E-3. Sample TIR (continued).

(CLASSIFICATION)	
(3) PAST: Assaulted Hill 457 (NB625305).	
c. UNIT: (2MRC/3/62/34MRD).	
(1) PRESENT: To continue offensive operation east on highway.	
(2) FUTURE: To link up with the 3MRB in ALSFELD (NB1922) NLT 27NOV99.	
(3) PAST: Crossed international border 18NOV99 to liberate oppressed populace.	
2. COMPOSITION: (62MRR/34MRD).	
a. 62MRR had 2xMRB, dsg 1 and 3. 1xArty Btry, dsg unk. 2xEngr Bn, dsg unk.	
b. 2MRB/62MRR had 3xMRC dsg 1, 2, and 3.	
c. 2MRC/3/62MRR had 1xHq Section and 3xMRP dsg 1, 2, 3.	
d. Ea MRP/2/3/62MRR had 3xMRS, dsg 1, 2, 3.	
3. STRENGTH: (2MRC).	
a. Personnel: (2MRC).	
(1) 2MRC had 93xpersonnel(6xOff/87xEM).	
(2) Hq Sec/2MRC had 6xpersonnel (3xOff - CO, PO, TO/3xEM 1SG, BMP driver/mechanic, BMP commander/gunner).	
(3) Ea MRP/2MRC had 29xpersonnel(1xOff - Plt Ldr/28xEM - 1xPlt SGT and 27xPlt mbrs).	
(4) Ea MRS/ea MRP/2MRC had 9xEM (1xSqd Ldr, 8xSqd mbrs).	
b. WEAPONS AND EQUIPMENT: (2MRP/2MRC).	
(1) Individual Weapons: (2MRP).	
(a) 7x9mm pistol (1xPlt Ldr, 1xea RPG-16 gunner, 1xea BMP driver/mechanic).	
(b) 16x5.45mm AK-74 rifles (1xea remaining EM except RPK-74 gunners).	
(c) 1x7.62mm SVD sniper rifle carried by sniper, 2MRP.	
(2) Crew-served Weapons: (2MRP).	
(a) 6x5.45mm RPK-74 LMG (2xea MRS/2MRP).	
(b) 3x58mm RPG-16 ATGL (1xea MRS/2MRP).	
(3) Other Weapons: (2MRP) Ea mbr/2MRP carried unk no RGD-5 and F-1 hand grenades.	
(4) Armored Vehicles: (2MRP) (3xBMP, ea armed with 1x73mmsmoothbore gun, 1x7.62mm coaxial MG, and 1xAT-3 SAGGER ATGM, 1xea MRS/2MRP).	
(5) Other Vehicles: Unk.	
(CLASSIFICATION)	

Figure E-3. Sample TIR (continued).

FM 34-52

(CLASSIFICATION)

(6) Communication Equipment: (2MRP).

(a) 3xR-123 transceivers, 1xea BMP/2MRP.

(b) 1xR-126 transceivers, 1xPlt Hq/2MRP.

(7) NBC Equipment: (2MRP).

(a) Individual:

(1) 29xShM protective masks (1xea mbr/2MRP).

(2) 29xU/I protective clothing sets (1xea mbr/2MRP).

(3) 29xU/I individual decon kits (1xea mbr/2MRP).

(b) Vehicular: (2MRP) 3xU/I air filtration systems (1xea BMP/2MRP).

(8) Specialized equipment: None.

4. **DISPOSITIONS:**

(a) CP, 3MRB/62/34MRD loc vic NB673344 in abandoned 2xstory building in HEIMBOLDSHAUSEN (NB6734) (H/S, CO, 2MRC/3MRB, DOI: 211200ZNOV99).

(b) CP, 2MRC/3/62/34MRD loc vic NB639310 in building at road intersection in RANSBACH (NB6331) (DOI: 211130ZNOV99).

(c) CP, 1MRP/2/3/62/34MRD loc vic NB626291, in building N of road junction WEHRSHAUSEN (NB6229) (DOI: 210800ZNOV99).

(d) CP, 3MRP/2/3/62/34MRD loc vic NB608324 in one-story, white building in HILMES (NB6032) (DOI: 210800ZNOV99).

(e) CP, artillery battery, FUD UNK, loc vic NB626334. (H/S, CO, 2MRC/3/62/34MRD DOI: 220400ZNOV99).

(f) CP, 2MRP/2/3/62/34MRD, Hill 457, loc vic NB625305. (DOI: 221330ZNOV99).

5. **TACTICS:** (2MRC/3/62/34MRD) To continue rapid advance toward ALSFELD (NB1922) where various U/I units will consolidate and then advance SW.

6. **TRAINING:** (2MRC/3/62/34MRD) Practiced small unit and company-size attack formation along with ground control of attack formations.

7. **COMBAT EFFECTIVENESS:** (2MRC/3/62/34MRD).

a. Losses: (2MRC).

(1) Personnel: 10xKIA in 2MRS/1/2/MRC due to artillery barrage on 20NOV99.

(2) Equipment: 1xBMP in 2MRS/1/2MRC due to artillery barrage on 20NOV99.

b. Replacements: (2MRC).

(CLASSIFICATION)

Figure E-3. Sample TIR (continued).

E-8

(CLASSIFICATION)

(1) Personnel: 5xEM received by 2MRS/1/2MRC to replace losses.

(2) Equipment: 1xBMP received by 2MRS/1/2MRC within 8 hours of loss.

c. Reinforcements: Unk to EPW.

d. Combat experience: Unk to EPW.

e. Morale: (2MRP/2MRC) Morale was good due to offensive going as planned and faith in leaders. PO, 3MRB/62/34MRC gives good political indoctrination.

f. Electronic technical data: Unk to EPW.

8. **LOGISTICS:** (2MRP/2/3/62/34MRD).

(a) Weapons and Ammunition: (2MRP).

(1) Weapons: (2MRP) All weapons were in excellent condition due to inspection in early Nov99. Spare parts for all weapons were stored in BMPs. No shortages of weapons or spare parts.

(2) Ammunition: (2MRP) All ammunition were in excellent condition as it was issued new and also was inspected in early Nov99. No shortages.

(b) Vehicles and POL: (2MRP).

(1) Vehicles: (2MRP) All BMPs were in good conditions due to regular maintenance. Ea BMP/2MRP carried its own spare parts and tool kit. No shortages of vehicle spare parts.

(2) POL: (2MRP) POL was resupplied ea evening by a U/I tanker truck at approximately 1800. No shortages.

(c) Food/Water: (2MRP).

(1) Food: (2MRP) All personnel eating field rations since offensive began. Each member eats 2xcanned rations each day. Resupply every 3xdays. Last resupply on 20NOV99. No shortages.

(2) Water: (2MRP) Water was obtained from local sources. Each member/2MRP has purification tablets to be used as necessary. No shortages.

(d) Communication Equipment: (2MRP) All transceivers are in good working order as they were inspected in early Nov99. Spare parts are stored in BMPs.

(e) Medical: (2MRP) Each member had 1xfirst-aid kit.

(f) NBC Equipment: (2MRP) All NBC gear was in excellent condition as it was inspected in late Oct99.

9. **MISCELLANEOUS:** (3MRB).

a. Personalities: (3MRB/62/34MRD).

(CLASSIFICATION)

Figure E-3. Sample TIR (continued).

FM 34-52

(CLASSIFICATION)					
Last Name	First Name	MNI	Rank	Psn	FUD
GARNOV	W.	MNU	MAJ	PO	3MRB
PANKRATOV	A.	MNU	CPT	CO	2MRC/3MRB
ZAGORSKIY	H.	MNU	SrSGT	1SG	2MRC/3MRB
MEL'NIKOV	C.	MNU	SrLT	Plt Ldr	1MRP/2/3MRB
KOVALEV	I.	MNU	SGT	Plt Ldr	2MRP/2/3MRB
KHOLODNOV	M.	MNU	JrLT	Plt Ldr	3MRP/2/3MRB

b. Code names/numbers: Unk to EPW.

c. Radio frequencies: (2MRC/3MRB) Frequencies for the R-123 transceiver on 22NOV99 were: Primary - 14.70MHz. Alternate - 18.36MHz. Frequencies changed daily at 2400 per unit SOL. Effective date: 22NOV99.

d. Call Signs: (2MRC/3MRB) Call signs for 22NOV99 were CO, 2MRC TASC 20; 1MRP/2MRC - PZQN 11; 2MRP/2MRC - PZQN 12; 2MRP/2MRC - PZQN 13. Call signs changed daily at 2400 per unit SOL. Effective date: 22NOV99.

e. Passwords: (2MRC/3MRB) Challenge for 22NOV99 was NOS; Countersign was UTR0M. Passwords changed daily at 2400 per unit SOP.

f. Obstacles: Unk to EPW.

g. PSYOP: Unk to EPW.

PART III - REMARKS

Recommend EPW for further interrogation on annual training competition at battalion and regimental levels.

(CLASSIFICATION)

Figure E-3. Sample TIR (continued).

<div style="border: 1px dashed black; width: 20px; margin: 0 auto; text-align: center;">0</div>	Attach to PW	<div style="border: 1px dashed black; width: 20px; margin: 0 auto; text-align: center;">0</div>
<p style="text-align: center;">Part A</p> Serial No. of Tag: <u>026AR17</u> Nationality of Capture Unit: <u>US</u> Capturing Unit: <u>US-A112/3</u> DTG of Capture: <u>110645Z Aug 99</u> Location of Capture: <u>CA123456</u> PW Name: <u>FLORES, JUAN</u> (Last Name, First, MI) PW Rank: <u>PVT</u> PW DOB: <u>15 MAY 79</u> PW Service Number: <u>6543210</u> Power Served by PW: <u>REPUBLIC OF ARMANDA</u> Part B attached to Equipment or Documents: <input checked="" type="checkbox"/> YES / NO Comments or remarks on reverse		
-----Perforation-----		
<div style="border: 1px dashed black; width: 20px; margin: 0 auto; text-align: center;">0</div>		<div style="border: 1px dashed black; width: 20px; margin: 0 auto; text-align: center;">0</div>
<p style="text-align: center;">Part B</p> Serial Number of Tag: <u>026AR17</u> Nationality of Capture Unit: <u>US</u> PW Name: <u>FLORES, JUAN</u> (Last Name, First, MI) PW Rank: <u>PVT</u> Power Served by PW: <u>REPUBLIC OF ARMANDA</u> DTG of Capture: <u>110645Z Aug 99</u> Location of Capture: <u>CA123456</u>		
Attach to PW equipment documents. Ensure all documents/equipment are secure in one package. Mark with X in box below if of particular intelligence importance. <div style="border: 1px solid black; width: 50px; height: 20px; margin: 10px auto;"></div>		

Figure E-4. Standardized EPW and personal equipment and document captive tag (STANAG 2044).

FM 34-52

(CLASSIFICATION)	
FM	G 2, 12 INF DIV
TO	G 2, XII CORPS
INFO	G 2, X CORPS
CLASSIFICATION/CAVEATS	
-	
SERIAL:	(U).
-	
PASS:	(U) OPTIONAL.
-	
COUNTRY:	(U).
-	
SUBJ:	IR <u>COMBAT LOSSES</u> (U)
-	
WARNING: (U) THIS IS AN INFORMATION REPORT, NOT FINALLY EVALUATED INTELLIGENCE. REPORT CLASSIFIED (CLASSIFICATION/CAVEATS, WITH CAVEATS ABBREVIATED).	
-	
DOI:	(U).
-	
REQS:	(U).
-	
SOURCE:	(U).
-	
SUMMARY:	(U).
-	
TEXT:	(U).
-	
COMMENTS:	(U).
//IPSP:	(U) <u>BT</u> //.
//COMSOBJ:	(U) <u>BT</u> //.
PROJ:	(U).
COLL:	(U) (OPTIONAL).
PREP:	(U).
ENCL: (U) TO FOLLOW: <u>1</u> ENCLOSURES. (OPTIONAL). WARNING: (U) REPORT CLASSIFIED (CLASSIFICATION/CAVEATS WITH CAVEATS SPELLED OUT).	
-	
DECL:	OADR ##
NOTE: LEFT MARGIN DASHES ENSURE PROPER SPACING BETWEEN PROSIGNS.	
(UNCLASSIFIED)	

Figure E-5. Format for intelligence information report (IRR).

*1. NAME OF COUNTRY

2. DATE OF INFORMATION (for example, YYMMDD or YYMMDD-YYMMDD)

3. DATE OF REPORT (for example, YYMMDD)

*4.A. FULL NAME (Must be listed in Roman letters in the order normally used by the individual, with surname in capital letters; accent on last name, if known; phonetic pronunciation, as appropriate.)

4.B. NAME(S) BY WHICH INDIVIDUAL PREFERS TO BE ADDRESSED

(1) IN OFFICIAL CORRESPONDENCE

(2) ORALLY AT OFFICIAL GATHERINGS

4.C. FULL NAME IN NATIVE ALPHABET (Include standard telegraphic code or other transcription code.)

4.D. VARIANTS, ALIASES, OR NICKNAMES

*5. RANK (List complete official rank)

5.A. ENGLISH LANGUAGE (List American equivalent.)

5.B. NATIVE

6. DATE OF RANK (for example, YYMMDD)

7. POSITION/BILLET

*7.A. PRESENT POSITION (List what the person is and where.)

7.B. MILITARY ADDRESS

7.C. DATE ASSUMED POSITION (for example, YYMMDD)

7.D. SCHEDULED DATE OF DEPARTURE (for example, YYMMDD)

7.E. NAME OF PREDECESSOR

(1) PREDECESSOR'S RANK

(2) PREDECESSOR'S BRANCH OF ARMED SERVICE

(3) DATE PREDECESSOR ASSIGNED (for example, YYMMDD)

(4) DURATION OF PREDECESSOR'S ASSIGNMENT (List from and to date in YYMMDD order.)

*8. BRANCH OF ARMED SERVICE (for example, Army, Navy, Air Force, Special Branch)

9. SPECIALITY/OTHER ORGANIZATIONS (List affiliation with Ministry of Defense, a space program, or other specialized agencies or programs.)

10. DATE OF BIRTH (for example, YYMMDD)

11. PLACE OF BIRTH (List town, state, province, country.)

Figure E-6. Format for biographic report.

FM 34-52

12. SEX
13. HOME ADDRESS
14. TELEPHONE NUMBER (Include area code, if applicable.)
14.A. HOME
14.B. WORK
15. MARITAL STATUS (List married, single, divorced, widowed, or separated.)
16. CITIZENSHIP (List country or countries where citizenship is held.)
17. ETHNIC GROUP (for example, Caucasian)
18. NATIONALITY
19. RELIGIOUS AFFILIATION
19.A. NAME (for example, Roman Catholic)
19.B. PRACTICING OR NON-PRACTICING
20. TITLES, HONORIFICS
21. HIGH ORDER DECORATIONS (List native, US, other country awards, by what government awarded, and when.)
22. PHYSICAL DESCRIPTION
22.A. FACIAL HAIR (List beard, mustache, other.)
22.B. TEETH (Yes or No. Note whether teeth are natural.)
22.C. HARD OF HEARING (Yes or No)
22.D. GLASSES (Yes or No)
22.E. COLOR OF EYES
22.F. BALD (Yes or No)
22.G. COLOR OF HAIR
22.H. WRITING HAND
22.I. POSTURE (List whether erect or round-shouldered.)
22.J. HEIGHT (List in inches.)
22.K. WEIGHT (List in pounds.)
22.L. BUILD (List small, medium, or large.)
23. MEMBERSHIP IN ORGANIZATIONS (List professional, social, military, and other organizations and inclusive date in YYMMDD order.)
24. PREFERENCES (List preferences for food, drink, tobacco, entertainment, sports, and hobbies.)
25. PUBLISHED WORKS--BY OR ABOUT INDIVIDUAL (List title and publication date of article or book. If an article, list name of publication in which article appeared.)

Figure E-6. Format for biographic report (continued).

26. CIVIL EDUCATION (List college or highest level schools, locations, major courses, degrees, honors, and inclusive dates in YYMMDD order.)
27. LANGUAGES (List proficiency, dialects, degree of fluency, and ability to act as a translator or interpreter.)
28. INTERNATIONAL TRAINING/TRAVEL (List countries, purpose, and inclusive dates in YYMMDD order.)
29. PHOTOGRAPH SUBMITTED (Yes or No)
30. DATE OF PHOTOGRAPH, IF SUBMITTED (for example, YYMMDD)
31. MILITARY SERVICE (Chronologically, list inclusive dates in YYMMDD order and locations. List all military schools, in-country and foreign; promotions and demotions by listing rank to which moved and effective date in YYMMDD order; foreign service; units served and position held; retired or reserve status; and involvement with programs, activities, and key people.)
32. FULL NAME OF SPOUSE
- 32.A. MAIDEN NAME (for example, ESCOBAL)
- 32.B. DATE OF BIRTH (for example, YYMMDD)
- 32.C. PLACE OF BIRTH (List town, state, province, and country.)
- 32.D. CITIZENSHIP (List country or countries in which citizenship held.)
- 32.E. ETHNIC GROUP
- 32.F. NATIONALITY
- 32.G. RELIGIOUS AFFILIATION
- (1) NAME (for example, Roman Catholic)
- (2) PRACTICING OR NON-PRACTICING
- 32.H. BACKGROUND (List education; languages; preferences in food, drink, hobbies, and entertainment; special interests; and professional societies and groups.)
33. NAMES OF CHILDREN (Include sex, date of birth in YYMMDD order, marital status, and any other items of interest such as schools, health, or military service.)
34. SIGNIFICANCE:
The following paragraphs are classified, except number 40.
35. POLITICS
36. MILITARY REPUTATION
37. CHARACTER
38. ACQUAINTANCES/RELATIONS INFLUENCE
39. PERSONAL CHARACTERISTICS
40. POLICE RECORD (Not a classified paragraph.)
41. EVALUATION
42. ADDITIONAL INFORMATION ON SPOUSE

Figure E-6. Format for biographic report (continued).

FM 34-52

PRECEDENCE/DTG
FM
TO
INFO
BT OR ZEN
CLASSIFICATION/CAVEATS/CODEWORDS
CITE:
SERIAL:
SUBJ: KNOWLEDGEABILITY BRIEF (Classification)
REF:
SUMMARY: (Classification) (Source description limited to 414 characters, 6 message lines)
TEXT:
1. (Classification) PERSONAL DATA:
1A. NAME:
1B. SRCNO: (14-characters)
1C. SRCNO1: (14-characters)
1D. SRCNO2: (14-characters)
1E. SRCNO3: (14-characters)
1F. CITIZEN: (2-characters)
1G. BIRTCITY: (30-characters including blanks)
1H. BIRTCRTY: (2-characters)
1I. BIRTDY: (YYMMDD -- 6-characters)
1J. PCO: (2-characters)
1K. LEFTDY: (YYMMDD -- 6-characters)
1L. INITCTDY: (YYMMDD -- 6-characters)
1M. LASTCTDY: (YYMMDD -- 6-characters)
1N. LASTCTRY: (YYMMDD -- 6-characters)
1O. LANGCOMP: (3-characters; 3 occurrence limit.)
2. (Classification) EDUCATION:
2A. C or M (1 character; YY-YY; educational institution in 76-characters including blanks; geographic coordinates in 15-characters without blanks; city name in 30-characters including blanks; country code in 2-characters; degree/certificate/diploma and major in 32-characters including blanks.

Figure E-7. Format for a knowledgeability brief.

2B-2E. (Include these subparagraphs as needed using format above.)

3. (Classification) EMPLOYMENT:

3A. YY-YY: (Employment installation in 76-characters including blanks; geographic coordinates in 15-characters without blanks; city name in 30-characters including blanks; country code in 2-characters; employment position and duties in 30-characters including blanks; security clearance in 1 character.)

3B-3G. (Include these subparagraphs as needed using format above.)

4. (Classification) MIL SERVICE:

4A. YY-YY: (Military installation in 76-characters including blanks; geographic coordinates in 15-characters without blanks; service component in 2-characters; rank in 2-characters; unit in 30-characters including blanks; city name in 30-characters including blanks; country code in 2-characters; military specialty and duties in 30-characters including blanks; security clearance in 1 character.)

4B-4T. (Include these subparagraphs as needed using format above.)

5. (Classification) SPECIFIC KNOWLEDGEABILITY: Free/text variable length (maximum 6,900-characters or 100 message lines) to address full source knowledgeability. The last two elements or paragraph, list applicable military equipment and IPSP codes, as follows:

//MILEQUIP: Two 8-CHARACTER CODE; CODE; CODE; CODE; CODE; CODE; CODE// (6-CODE LIMIT).

//IPSP: Six 7-CHARACTER CODE; CODE; CODE; CODE; CODE; CODE; CODE; CODE// (8-CODE LIMIT).

6. (Classification) COLLECTOR'S COMMENTS: Free text/variable length (maximum 1,380-characters or 20 message lines) to address collection capability.

7. (Classification) GUIDE: Free text/variable length (maximum 1,380-characters or 20 message lines) to address desired method of intelligence tasking.

DECL: OADR

Figure E-7. Format for a knowledgeability brief (continued).

FM 34-52

(CLASSIFICATION)	
SOURCE NAME	<u>YUSSEF MASRIM AL-MUFAJIR</u> DATE <u>7 OCT 99</u>
SOURCE'S RANK AND SERVICE/SERIAL NO.	<u>PVT 1234567</u>
SOURCE'S DPOB	<u>29 SEP 80, MEDINA</u>
SOURCE'S UNIT	<u>180D/2/3/MAC</u> INTG SEQUENCE <u>017</u>
DOC/EQUIP CAPTURED W/SOURCE	<u>AK-47, PICTURE OF FATHER</u>
CIVILIAN CAREER	<u>STUDENT</u>
MILITARY CAREER	<u>RIFLEMAN</u>
SPECIALIST KNOWLEDGE	<u>NONE</u>
DURATION OF INTG	<u>30 MIN</u> INTG LOCATION <u>AB 123456</u>
REPORTS GENERATED	<u>PERS LOSSES</u>
INFO OBTAINED SUMMARY	<u>SOURCE UNIT SUFFERED 60% CASUALTIES DURING COALITION ATTACK.</u>
INTG NAME AND UNIT	<u>SFC SMITH</u>
LANGUAGE USED	<u>ARABIC</u> SOURCE'S MP SERIAL No. <u>US-2307.9/2</u>
(CLASSIFICATION)	

Figure E-8. Sample summary interrogation report.

APPENDIX F

COMMAND LANGUAGE PROGRAM

Foreign language knowledge is a perishable skill. Without constant reinforcement, this knowledge quickly fades. In a combat situation, this knowledge will be

most critical. It is incumbent on the commander to establish and maintain an effective CLP.

STANDARDS

The goal for any language maintenance program is to have all linguists perform critical wartime mission tasks proficiently. Scoring 2/2/2 or better on the listening, reading, and speaking portion of the Defense Language Proficiency Test (DLPT) is the minimum standard for foreign language proficiency. However, there are several reasons why this should not be the sole criteria for judging the effectiveness of a language maintenance program nor an individual's proficiency.

Languages have different degrees of difficulty. The Defense Language Institute, Foreign Language Center (DLIFLC) has divided languages into four categories according to difficulty for an English speaker. The

romance languages belong to Category I (easiest), while most of the Asian languages belong to Category IV (hardest). Therefore, a 2 on the DLPT for Korean does not correspond to a 2 for French.

There are several versions of the DLPT for each language. A 2 result on a version I examination is not the same as a 2 result on a version III examination, even in the same language. There are different forms (For example, A, B, or C) within each examination version.

Nevertheless, unless there is a qualified native speaker who can evaluate language proficiency, the DLPT can be used to evaluate language maintenance program effectiveness.

METHODS

The best method of learning and maintaining a foreign language is total immersion. Opportunities for total immersion include in-country temporary duty and teaching institutions. Unfortunately, in-country experience is not readily available for all languages, and immersion courses can be cost prohibitive.

A substitute for immersion training is one-on-one instruction or conversation with a native speaker. This can be part of the formal instruction at DLIFLC, Presidio of Monterey, CA; at the Foreign Language Training Center, Europe (FLTCE), Garmisch, Germany; and university refresher training courses or a DA-sponsored institute. It can also be done through hiring native speakers at unit locations.

The most prevalent, but probably least effective, method is through self-study materials, such as US Army Forces Command Language Maintenance Refresher and Improvement Course (FLAMRIC) and foreign language tapes. Most of these materials are available from DLIFLC or local language learning centers.

There is satellite communications for learning which transmits in-language news broadcasts from countries around the world.

An effective CLP begins with the commander. He must have a clear and accurate picture of his language mission requirements and be accountable for the CLP.

A command language council is formed to assist the commander. Council recommendations should become policy following command endorsement. This council—

- Consists of unit members who have a CLP interest.
- Consists of members who are appointed on orders.
- Should meet at least quarterly and follow an agenda.
- Should prepare and disseminate meeting minutes to unit linguists.

The CLP manager (CLPM) chairs the CLP council. Units commanded by a colonel should have a full-time CLPM. In lieu of rank and duty position, the CLPM should be appointed based on academic credentials or

FM 34-52

experience. The CLPM's tenure should be at least one year or longer.

The CLPM should maintain an individual linguist data base, with the following information:

- Duty assignment.
- Primary military occupational specialty (MOS).
- On-going language training.
- Post-DLIFLC language training.
- Expiration term of service (ETS) date.
- Permanent change of station (PCS) and date eligible for return from overseas (DEROS) date (if applicable).
- Foreign language proficiency pay (FLPP) status.
- DLPT dates and scores, to include which version.
- Required DLPT test.
- Individual training plan.
- Year-to-year test results.
- Current DA Form 330 (Language Proficiency Questionnaire).

The command should have a detailed SOP covering all CLP aspects. It should be specific in task assignments and self-explanatory. It is updated regularly and becomes an integral part of the unit or command SOP.

Unit language training time, governed by AR 611-6, is designated at regular intervals on the training schedule, and should take priority over competing and unscheduled training. Each linguist should have the opportunity to attend a specified amount of language training with established objectives and goals.

Units should have a refresher language training program. Self-study materials should be available, and off-duty use encouraged.

The CLPM should be aware of adult language education courses in the community. Both duty-hour and off-duty hour attendance are encouraged.

Opportunities for operational readiness training (REDTRAIN) should be used in support of the CLP. These opportunities include, but are not limited to, forward area training, live environment training, and summer language programs.

Monetary support for language maintenance programs comes mainly from REDTRAIN funds. These funds are normally located at major Army commands and are available to subordinate units. However, this should not preclude use of a unit's regular funds to support language sustainment when available.

Funding to support CLPs must be identified and documented regularly. These requirements must be addressed in annual budget planning. The CLP should also be represented in long-range budget planning. CLP requirements should be separate from other training budgets.

A good incentive is the FLPP for qualified linguists, depending on how they score on their DLPT. Only qualified linguists are eligible to receive FLPP.

A state-of-the-art language training vehicle is the teletraining network, or commonly referred to as video teletraining (VTT).

The VTT system was used by DLIFLC to teach Arabic to troops being deployed to Southwest Asia. DLIFLC broadcasts Arab language instruction to Fort Hood and Fort Huachuca. Other critical instruction was passed through the system.

The VTT is versatile and has many applications. Video and audio can be transmitted from one site to any number of receiving sites. In a two-way interactive mode, two sites can hold a bidirectional video and audio conference. In the multipoint mode, up to eight locations can hold a conference. The host site transmits the video and audio, while other locations receive the host's audio and video, plus all audio from the remaining sites. Any site can request, during the conference, to become the host site.

DLIFLC is committed to the VTT concept. It is ready to assist units having VTT capability with their remedial foreign language sustainment and enhancement programs.

For information concerning VTT language training, contact DLIFLC's Distance Education Division at DSN 878-5746/5747; Commercial (408) 647-5746/5747; or FAX at DSN 878-5512 or Commercial (408) 647-5512.

VTT is a proven cost effective and viable language training tool; for example, training soldiers in their units with qualified native speakers, which dramatically reduces travel and per diem costs.

APPENDIX G

INDIVIDUAL AND COLLECTIVE TRAINING

"In no other profession are the penalties for employing untrained personnel so appalling or so irrevocable as in the military."—General Douglas MacArthur.

Interrogator employment during OPERATION DESERT STORM demonstrated that units whose mission training plans (MTPs) were battle focused and based on the principles of training outlined in FM 25-100 and FM 25-101, accomplished the EPW and DOCEX mission more efficiently and timely.

The commander bears the ultimate responsibility for training his soldiers to fight and win. This appendix is

designed to make the interrogation unit commander aware of aspects to consider when developing unit training programs.

There are no commissioned interrogation officers. The commissioned interrogation specialty was eliminated in 1970. The Interrogation Warrant Officer (351E), and the Senior Enlisted Interrogator (97E4L) advise the commander on the training and employment of interrogators. They provide the technical expertise required to develop the unit mission-essential task list (METL) and training plans and exercises to support that METL.

MISSION-ESSENTIAL TASK LIST

To train interrogators in the areas critical to the unit's mission accomplishment, the commander (CI/Interrogation Company or I&S Company) develops a complete and accurate METL. During the METL development process, the commander—

- Analyzes the MI battalion commander's restated wartime mission and approved METL; identifies specified and implied tasks.
- Uses situation training exercises (STXs) and field training exercises (FTXs) in ARTEP 34-298-10-MTP to determine collective tasks in support of critical wartime missions.
- Sequences collective tasks as he expects them to occur during the execution of the company's wartime mission.
- Obtains battalion commander's approval of the company METL.
- Briefs company leadership (officers and NCOs); uses soldiers training publications, soldiers manuals, and MTPs to identify leader and soldier tasks to support the collective critical tasks which comprise the METL.

When developing the METL, the commander keeps in mind, regardless of echelon, that interrogators have a mission to perform at the next lower echelon as GS or DS. For this reason, they must train and practice performing their mission at the assigned and lower echelon, and deploy with both echelons.

In addition to understanding the METL of your unit, you must be familiar with the METL of supported staffs and units. Other unit METLs to consider are--

- Supported S2s and the maneuver brigade and battalion staffs to which they belong. Train with these staffs during FTXs and command post exercises (CPXs) to facilitate team cohesiveness for combat. The S2 should know and train with his interrogation support team to prepare for wartime operations.
- Train and deploy with CI personnel. Interrogation and CI personnel should cross-train on each others respective wartime critical tasks.
- Train with combat arms units. Interrogators should train and emphasize the importance of tagging and evacuating EPWs and CEDs. Stress that EPWs and CEDs provide information that saves lives.

FM 34-52

JOINT MILITARY INTELLIGENCE AND MILITARY POLICE TRAINING

OPERATIONS URGENT FURY, JUST CAUSE, and DESERT STORM demonstrated the need for interrogators and MP to conduct integrated training with regard to EPW and civilian internee operations.

For effective, meaningful training to occur, commanders must plan, develop, and coordinate many tasks. Interrogators must be familiar with the METL of the MP unit assigned to your echelon with regard to EPW

operations. Without integrating the two METLs, you cannot develop scenarios that allow soldiers to train in a battle-focused environment. The two units must learn to work together and understand the requirements and functions each unit will have to perform in wartime. Members of the band are trained and may be employed as augmentees to the holding area perimeter security force.

EXERCISE REQUIREMENTS

In addition to normal personnel and equipment required of any unit exercise, the following must be planned for and considered.

SCENARIO

The most time consuming and complicated portion of an interrogation exercise is scenario development. Included in the scenario must be reasonable actions of enemy and friendly forces.

Stories must be developed for EPWs and civilian internees; for example, as in the technical support packages and interrogator comprehensive evaluation. These stories should be entered into an automated HUMINT data base, and should interact with each other at least minimally. For example:

- Units should cross match.
- Missions should fit together.
- Some degree of personality (names of leaders and soldiers) should be shared by personnel.

It is not necessary that all EPWs and civilian internees have stories that include information of intelligence value nor that stories be complete in all aspects. There should be enough material in the stories to provide a realistic "skeleton" on which role players can build.

If possible, interrogators should develop or assist with story development. The stories should tie into real world exercise play and provide indicators of enemy COAs to the G2. Tying EPW and CI stories to exercise play facilitates incorporating EPW play into G2 exercise planning and execution. This will help identify and fix many shortcomings in the stories.

PERSONNEL

Additional personnel must be employed to make an interrogation exercise successful. Personnel will be needed to serve as EPWs, civilian internees, medical personnel, interpreters, CI teams, and EPW civilian internee guards for lower echelon units. The numbers of personnel needed can be varied and personnel may be reinserted any number of times, in any number of roles.

The minimum number of personnel serving as EPWs and civilian internees at any one time should not be allowed to go below 10 to 15. Personnel should be able to speak a foreign language; preferably, languages of assigned interrogators. This allows for optimum training and practice in performing the actual job of an interrogator.

Possible sources for linguistically capable EPW and civilian internee role players include—

- Other interrogation units.
- EW and CI personnel.
- PYSOP personnel.
- MP personnel.
- CA personnel.

Linguistically capable personnel may also be in other MOSs and units not normally associated with foreign language capabilities.

Another source of linguistic support is the US Army Reserve (USAR) and the Army National Guard (ARNG) units for AC units and vice versa. A few personnel with languages not indigenous to the unit should be included so interpreters can be trained when used.

G-2

If possible, at least one insertion of mass numbers of EPWs and civilian internees should occur. The number of personnel should be at least double the number of available interrogators. One way of simulating this is to—

- Insert a large quantity of individuals.
- Allow a short time for MP and interrogator personnel to work with this.
- Remove a portion of the personnel.
- Immediately reinsert them as new EPWs and civilian internees. The knowledgeability and cooperativeness of the sources should be mixed; for example, some may be of CI interest, some may have no information, and a few may refuse to break.

DOCUMENTS

Documents present another time consuming and difficult consideration for interrogation operation exercises. Documents should be in foreign languages; numerous documents should be relevant to scenario documents which are developed to interact with the EPWs and civilian internees and as stand-alone intelligence sources.

The number of documents used during an exercise should be excessive; large quantities of documents should be input into the scenario at the same time EPWs are being inputted. This allows simulation of EPWs and civilian internees, and documents arriving on the same sources of transportation.

MULTIPLE EXERCISE LOCATIONS

In order to exercise evacuation of EPWs and civilian internees, support to lower echelons' multiple exercise locations is necessary. These locations do not need to be drastically separated, but should not be within sight of each other.

For example, location to simulate a medical aid station should also be included along with personnel to simulate medical personnel. This allows personnel to practice interrogating EPWs and civilian internees in the medical evacuation system. Having multiple locations serves several purposes.

- Both interrogation and MP units have functions that must be performed at a lower echelon.
- Interrogators must be able to support the lower echelons with interrogations. This means teams must be able to deploy and act without normal unit leadership.
- Coordination must be affected with the supported lower echelon unit.
- Reports must be transmitted to the supported unit and accompany EPWs being evacuated.
- MP must receipt and receive EPW and civilian internees from lower echelons and guard them during the evacuation process from lower echelon to assigned echelon.

There is also a need to practice having multiple EPW and civilian internee facilities at the assigned echelon. When these are established, MP and interrogation assets must be divided in order to operate the additional facilities.

An additional aspect of using additional locations is training of interrogation and MP units to function with reduced staffing necessitated by performing multiple missions simultaneously.

OTHER SUPPORT

For corps interrogation platoon exercises, a food services section of the HHS company should be deployed in support of the exercise. This allows the food service section to practice operating two separate mess facilities required by doctrine.

GLOSSARY

AC	Active Component		
ACE	analysis and control element	CM&D	collection management and dissemination
ACR	armored cavalry regiment		
ADA	air defense artillery	CMEC	Captured Materiel Exploitation Center
AI	area of interest	CMO	civil-military operations
AIRDOC	Air Force document	co	company
AO	area of operations	COA	course of action
armd	armored	coll	collection
ARNG	Army National Guard	CONUS	continental United States
ARTEP	Army Training Evaluation Program	CP	command post
ASAS	All-Source Analysis System	CPR	common point of reference
ASPS	all-source production section	CPT	captain
ATGM	antitank guided missile	CPX	command post exercise
		CS	combat support
		CSS	combat service support
BICC	battlefield information control center		
BIRTCRTY	birth country		
BIRTCITY	birth city	DA	Department of the Army
BIRTDY	birth date	DCPR	destination common point of reference
bn	battalion	DECL	declassify
BSA	brigade support area	DEROS	date eligible for return from overseas
BT	message break indicator	DIA	Defense Intelligence Agency
		DISCOM	division support command
		DISUM	daily intelligence summary
CA	Civil Affairs	div	division
CAP	civic action program	DLEA	drug and law enforcement agency
C ³	command, control, and communications	DLPT	Defense Language Proficiency Test
C ³ I	command, control, communications, and intelligence	DLFLC	Defense Language Institute Foreign Language Center
C-E	communications-electronics	doc	document
C&E	collection and exploitation	DOCEX	document exploitation
CEE	captured enemy equipment	DOD	Department of Defense
CCIF	combined corps interrogation facility	DOI	date of information
CED	captured enemy document	DOS	disk operating system
CEM	captured enemy materiel	DPOB	date and place of birth
CHA	central holding area	DPRK	Democratic People's Republic of Korea
CI	counterintelligence	DS	direct support
CID	Criminal Investigation Division	DSA	division support area
CIF	Corps Interrogation Facility	dsq	designation
CLP	Command Language Program	DSN	digital support network
CLPM	Command Language Program Manager	DST	decision support template
		DTG	date-time group

FM 34-52

ea	each	hq	headquarters
EAC	echelons above corps	HHC	headquarters and headquarters
ECB	echelon corps and below		company
ECM	electronic countermeasures	HHS	headquarters, headquarters and
EM	enlisted member		service
encl	enclosure	HIC	high-intensity conflict
enr	engineer	HPT	high-payoff target
EPW	enemy prisoner of war	H/S	hearsay
equip	equipment	HUMINT	human intelligence
ETS	expiration term of service	HVT	high-value target
EW	electronic warfare	hwy	highway
FAX	facsimile	ICF	Intelligence Contingency Fund
Feb	February	ICPR	initial common point of reference
FEBA	forward edge of the battle area	I&E	interrogation and exploitation
FIS	foreign intelligence and security	IEW	intelligence and electronic warfare
FLAMRIC	US Army Forces Command Language Maintenance Refresher and Improvement Course	IHA	initial holding area
FLPP	foreign language proficiency pay	IIR	intelligence information report
FLTCE	Foreign Language Training Center, Europe	IMINT	imagery intelligence
FM	field manual	info	information
FS	fire support	intg	interrogation
FTX	field training exercise	INTSUM	intelligence summary
		INTREP	intelligence report
		IO	information objectives
		IPB	intelligence preparation of the battlefield
		IPW	prisoner of war interrogation
G1	Assistant Chief of Staff (Personnel)	IR	intelligence requirements
G5	Assistant Chief of Staff (Civil Affairs)	I&S	intelligence and surveillance
GAZ	Soviet truck	I&W	indications and warning
GC	Geneva Convention Relative to the Protection of Civilian Persons in Time of War of August 12, 1949	J5	Plans and Policy Directorate
GPW	Geneva Convention Relative to the Treatment of Prisoners of War of August 12, 1949	JCMEC	Joint Captured Materiel Exploitation Center
GS	general support	JIF	Joint Interrogation Facility
GSR	ground surveillance radar	JTF	joint task force
GWS	Geneva Convention for the Amelioration of the Wounded and Sick in Armed Forces in the Field of August 12, 1949	jr	junior
		JUMP	job, unit, mission, and PIR, IR, and SIR
		k	thousand

Glossary-2

KB	knowledgeability briefs	NCOIC	noncommissioned officer in charge
		NEO	noncombatant evacuation operations
		no	number
		NSA	National Security Agency
LANGCOMP	language competency		
ldr	leader		
LIC	low-intensity conflict		
LLSO	low-level source operations	OADR	Originating Agency's Determination Required
loc	location	OB	order of battle
LN	local national	OBSTINTEL	obstacle intelligence
LRS	long-range surveillance	OCONUS	outside continental United States
LZ	landing zone	OCS	officer candidate school
		off	officer
		OP	observation post
MASINT	measurement and signature intelligence	OPCON	operational control
mbr	member	OPLAN	operations plan
MDCI	multidiscipline counterintelligence	OPORD	operations order
MED	minimum essential data	OPSEC	operations security
METL	mission essential task list		
METT-T	mission, enemy, troops, terrain, and time available		
MHz	megahertz	PC	personal computer
MI	military intelligence	PCS	permanent change of station
MIC	mid-intensity conflict	PERINTREP	periodic intelligence report
MID	military intelligence detachment	pers	personnel
mil	military	PHA	permanent holding area
misc	miscellaneous	PIR	priority intelligence requirements
MN/I	middle name or initial	plt	platoon
MOS	military occupational specialty	PM	Makarov pistol (Soviet)
MP	military police	PO	political officer
MRC	motorized rifle company	POC	point of capture
MRD	motorized rifle division	POL	petroleum, oils, and lubricants
MRR	motorized rifle regiment	prep	preparation
MRS	motorized rifle squad	proj	project
MS	microsoft	PSA	post-strike assessment
MSR	main snpply route	PSYOP	psychological operations
MTF	Message Text Format	PW	prisoner of war
NA	not applicable	QSTAG	Quadripartite Standardization Agreement
NAI	named area of interest		
NATO	North Atlantic Treaty Organization	RAM	random access memory
NAVDOC	Navy document	RC	Reserve Components
NBC	nuclear, biological, and chemical	REC	radio electronic combat
NCA	national command authority	recon	reconnoiter
NCO	noncommissioned officer	REDTRAIN	readiness training

FM 34-52

RIF	reconnaissance in force	UCMJ	Uniform Code of Military Justice
		U/I	unit of issue
		unk	unknown
S&T	scientific and technical	USAR	United States Army Reserve
S2	Intelligence Officer	USMTF	United States Message Text Format
SALUTE	size, activity, location, unit, time, equipment	UTM	universal transverse mercator (grid)
sec	section		
SFG	Special Forces Group		
SFGA	Special Forces Group (Airborne)	vic	vicinity
SJA	staff judge advocate	VTT	videoteletraining
SIGINT	signals intelligence		
SIR	specific information requirements		
SITMAP	situation map	w	with
SOF	special operations forces		
SOP	standing operating procedure		
SOI	signal operation instruction	XO	executive officer
SOR	specific operational requirement		
sqd	squad		
sr	senior		
srchno	search number		
SSO	special support office		
STANAG	Standardization Agreement		
STX	situation training exercise		
SUPINTREP	supplementary intelligence report		
SVD	Soviet rifle		
SW	southwest		
TCAE	technical control and analysis element		
TE	tactical exploitation		
TECHDOC	technical document		
TECHINT	technical intelligence		
TEL	transporter-erector-launcher		
THA	temporary holding area		
TIF	Theater Interrogation Facility		
TIR	tactical interrogation report		
TOC	tactical operations center		
TOE	tables of organization and equipment		
TQ	tactical questioning		
TRADOC	United States Army Training and Doctrine Command		
TSA	technical support activity		

Glossary-4

REFERENCES

SOURCES USED

These are the sources quoted or paraphrased in this publication.

Army Publications

AR 310-50. Authorized Abbreviations and Brevity Codes. 15 November 1985.
 DA Form 330. Language Proficiency Questionnaire. July 1985.
 AR 350-30. Code of Conduct/Survival, Evasion, Resistance and Escape (SERE) Training. 10 December 1985.
 AR 380-5. Department of the Army Information Security Program. 25 February 1988.
 FM 21-26. Map Reading and Land Navigation. 30 September 1987.
 FM 21-31. Topographic Symbols. 19 June 1961.
 (C)FM 21-78. Resistance and Escape (U). 15 June 1989.
 FM 34-2. Collection Management. 20 October 1990.
 FM 34-3. Intelligence Analysis. 15 March 1990.
 FM 34-54. Battlefield Technical Intelligence. 5 April 1990.
 FM 34-60. Counterintelligence. 5 February 1990.
 FM 34-130. Intelligence Preparation of the Battlefield. 23 May 1989.
 FM 100-20. Low Intensity Conflict. 5 December 1990.
 FM 101-5-1. Operational Terms and Symbols. 21 October 1985.
 STP 21-1-SMCT. Soldier's Manual of Common Tasks, Skill Level 1. 1 October 1990.
 STP 21-24-SMCT. Soldier's Manual of Common Tasks, Skill Levels 2-4. 10 January 1989.
 STP 34-97E1-SM. Soldier's Manual, Skill Level 1, MOS 97E, Interrogator. 27 June 1990.

DOCUMENTS NEEDED

These documents must be available to the intended users of this publication.

DA Form 1132-R. Prisoner's Personal Property List - Personal. April 1986.
 DA Form 2028. Recommended Changes to Publications and Blank Forms. February 1974.
 DA Form 2662-R. United States Army EPW Identification Card. May 1982.
 DA Form 4237-R. Prisoner of War Personnel Record. August 1985.
 DA Form 5976. Enemy Prisoner of War Capture Tag. January 1991.
 DODD 5100.77. Department of Defense Law of War Program.
 AR 381-10. US Army Intelligence Activities. 1 July 1984.
 AR 12-15. Joint Security Assistance Training (JSAT) Regulation. 28 February 1990.
 AR 190-8. Enemy Prisoners of War - Administration, Employment, and Compensation. 1 June 1982.
 AR 190-57. Civilian Internees - Administration, Employment, and Compensation. 4 March 1987.
 AR 210-174. Accounting Procedures for Prisoners' Personal Property and Funds. 17 September 1986.

FM 34-52

AR 500-51. Emergency Employment of Army and Other Resources Support to Civilian Law Enforcement. 1 July 1983.
AR 611-6. Army Linguist Management. 16 October 1985.
FM 19-4. Enemy Prisoners of War, Civilian Internees, and Detained Persons. 23 May 1984.
FM 25-100. Training the Force. 15 November 1988.
FM 25-101. Battle Focused Training. 30 September 1990.
FM 27-10. The Law of Land Warfare. 18 July 1956.
FM 34-1. Intelligence and Electronic Warfare Operations. 2 July 1987.
(S-NF)FM 34-60A. Counterintelligence Operations (U). 6 June 1989.
FM 71-101. Infantry, Airborne, and Air Assault Division Operations. 26 March 1980.
FM 100-5. Operations. 5 May 1986.
(S)TC 34-5. Human Intelligence Operations (U). 3 October 1988.
ARTEP 34-298-10-MTP. Mission Training Plan for Interrogation Platoon Military Intelligence Battalion Light Infantry Division. 8 October 1991.
STP 34-97E24-SM-TG. Soldier's Manual, Skill Levels 2/3/4 and Trainer's Guide, MOS 97E, Interrogator. 27 June 1990.
(S-NF)DIAM 58-13. Defense Human Resources Intelligence Collection Procedures (U). 28 March 1988.

Standardization Agreements (STANAGs)

2033. Interrogation of Prisoners of War. Edition 6.
2044. Procedures for Dealing with Prisoners of War. Edition 5.
2084. Handling and Reporting of Captured Enemy Equipment and Documents, Edition 5.

INDEX

- A**
- approach phase. See also interrogation phases.
 approach combinations, 3-13 through 3-20
 developing rapport, 3-12, 3-13
 part of interrogation phase, 3-5, 3-10
 rapport postures, 3-11
- B**
- battle damage assessment (BDA). See IEW tasks.
- BEST MAPS, 3-32, 3-33
- briefings, 3-30
- C**
- captured enemy documents
 accountability of, 4-6
 as sources of information, 2-17, 3-1, 4-1, 4-13
 definition and types of, 1-12, 4-1, 4-9
 disposal of, 4-13
 evacuation of, 4-4, 4-12, 4-14
 exploitation of, C-1
 grouping of, 4-12
 inventory of, 4-7
 logging of, 4-7, 4-8
 tracing of, 4-7
 transmittal of, 4-6, 4-12
- CED. See captured enemy documents.
- Command and Language Program (CLP), F-1
- conflicts
 types of, 1-16
- Corps Interrogation Facility (CIF), 2-10, 2-11, 4-5
- counter-drug operations
 use of interrogators, 1-5
- D**
- debriefings
 OPSEC requirement, 3-31
 responsibilities during, 3-31
 strategic, 3-31
- E**
- enemy. See METT-T factors.
- enemy prisoner of war (EPW)
 as sources of information, 2-17
 at CIF, 2-10
 at TIF, 2-12
 evacuating and guarding, 2-9
 when wounded, 2-12
- F**
- force protection. See IEW tasks.
- G**
- Geneva Conventions. See GWS, GPW, and GC.
- GWS, GPW, and GC, 1-14, 1-16
 command responsibilities, 1-7, 1-9
 coordinating with SJA, 1-9, 3-14
 definition of, iv, v, 1-11
 posting Articles of, 3-14
 protected persons rights vs security needs, D-1
 violations of, 3-16
- H**
- hearsay information, 3-9, 3-24
- high-intensity conflict (HIC). See conflicts.
- human intelligence (HUMINT), 1-2
- I**
- IEW tasks
 BDA, 1-5
 force protection, 1-5
 I&W, 1-3
 IPB, 1-3, 1-4
 overall objective statement samples B-11, B-13

FM 34-52

situation development, 1-5
target development and target acquisition, 1-5

imagery intelligence (IMINT), 1-2

indications and warning (I&W). See IEW tasks.

individual and collective training, G-1

information objectives, 3-31

Intelligence Information Report (IIR). See reports.

intelligence preparation of the battlefield (IPB). See IEW tasks.

intelligence requirements (IR)
screening for, 3-2

interrogation operations
cultural aspects on, 1-5
factors affecting, 1-5, 1-6
IEW support in, 1-1
offensive and defensive, 1-5

interrogation phases, 3-5, 3-7 through 3-28

interrogations
architecture, 2-1
debriefing, 3-31
in armored and mechanized infantry operations, 2-16
strategic, 3-31
objective of, 1-7, 1-17
prohibition against use of force, 1-7
types of, 1-7 through 1-9
with interpreters, 3-29

interrogation support in LIC, 2-21

interrogators
characteristics of, 1-12 through 1-16
functions of, 3-1
in defensive operations, 2-20
in GS and DS role, 2-23
in offensive operations, 2-18

Index-2

Interrogators Guide, 3-23

K

Knowledgeability Brief (KB). See Reports.

L

leads

hot and cold, 3-24

M

Message Text Format (MTF), E-1

METT-T factors

enemy, 1-6
mission, 1-5
terrain, 1-6
time available, 1-6
troops, 1-6

mission essential task list (METL), G-1

mission support. See METT-T factors.

military police, 2-1, 2-9, 2-13, 2-24, 3-2, 4-5, 4-13

P

planning and preparation, 3-5, 3-7 through 3-10. See also interrogation phases.

Prisoner of War Information System (PWIS), 2-1

Q

Quadripartite Standardization Agreements (QSTAGs), v

questioning phase, 3-7, 3-20 through 3-26. See also interrogation phases.

hearsay information, 3-24

Interrogators Guide, 3-23

leads, 3-24

questioning guides, B-1, C-1

questions to avoid, 3-23

sequencing, 3-24 through 3-26

spot reportable information, 3-23, 3-24

techniques, 3-21, 3-22, C-4

R

reporting phase, 3-28. See also interrogation phases.

Reports

Biographic Report, E-1, E-13
 Captive Tag, E-1, E-11
 captured document log format, 4-8
 captured document tag format, 4-4
 CED transmittal, 4-6
 Detainee Personnel Record, 3-3
 EPW Capture Tag, 3-8
 EPW ID Card, 3-27
 IEW process, 1-16, 2-1
 IIR, E-1, E-12
 Interrogation Report, E-1, E-18
 Knowledgeability Brief, E-1, E-16
 SALUTE Report, 1-6, 3-21, E-1, E-3
 screening format, 3-6
 TECHINT Spot Report, E-1, E-4
 TIR, E-1, E-5

responsibilities of

capturing unit, 2-9, 4-5
 commanders, 1-9, 2-1, 2-21
 Provost Marshal, 2-10
 team leaders, 2-1, 4-5

S**screening**

CI interest in, 3-2
 definition and types of, 3-2 through 3-6
 priorities, 3-7

signals intelligence (SIGINT), 1-2

situation development. See IEW tasks.

size, activity, location, unit, time, equipment (SALUTE). See reports.

sources

assessing, 3-5
 breaking points of, 3-13
 definition and types of, 1-10

Special Forces, 2-14

spot reportable information, 3-23, 3-29, E-1, E-4

Standardization Agreements (STANAGs)

1059, iv, 4-4
 2033, iv
 2044, v
 2084, v, 4-1
 assessment codes, 3-29

strategic intelligence components, 3-32, 3-33

strategic intelligence cycle, 3-33

T

Tactical Interrogation Report (TIR). See Reports.

target development and target acquisition. See IEW tasks.

technical documents (TECHDOCs), 4-5, 4-9

Technical Intelligence (TECHINT). See Reports.

termination phase. See also interrogation phases.
 procedures, 3-26
 reasons for, 3-28

terrain. See METT-T factors.

terrorists, 2-18

Theater Interrogation Facility (TIF)

functions of, 2-12
 mission, 2-22

time available. See also METT-T factors.
 at operational and strategic levels, 1-6
 at tactical level, 1-6

translations

reports, 4-10
 types of, 4-9

FM 34-52

troops. See METT-T factors.

U

UCMJ, iv, 1-9, 1-12

Extract, A-1

FM 34-52
28 SEPTEMBER 1992

By Order of the Secretary of the Army:

GORDON R. SULLIVAN
General, United States Army
Chief of Staff

OFFICIAL:

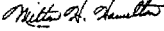
MILTON H. HAMILTON
Administrative Assistant to the
Secretary of the Army
02404

DISTRIBUTION:

Active Army, USAR, and ARNG: To be distributed in accordance with DA Form 12-11E, requirements for FM 34-52, Intelligence Interrogation (Qty rqr block no. 1130).

Senator LEVIN. All right. Now, in an annex in the Taguba Report it says the following as being a permissible technique for use in the Iraqi theater: “The interrogation officer in charge will submit memoranda for the record requesting harsh approaches for the commanding general’s approval prior to employment—sleep management, sensory deprivation, isolation longer than 30 days, and dogs.”

Secretary Cambone, were you personally aware that permissible interrogation techniques in the Iraqi theater included sleep management, sensory deprivation, isolation longer than 30 days, and dogs?

Secretary CAMBONE. No, sir. That list, both in terms of its detail and its exceptions, was approved at the command level in the theater.

Senator LEVIN. That was a command-level approval?

Secretary CAMBONE. As far as I understand it, yes, sir.

Senator LEVIN. Mr. Secretary, you said that you had decided, right at the beginning, that the Geneva Conventions would apply to our activities in Iraq.

Secretary CAMBONE. Yes, sir.

Senator LEVIN. Yet Secretary Rumsfeld repeatedly has made a distinction between whether or not those Geneva Conventions rules must be applied, whether people—prisoners will be treated, “pursuant to those rules” or “consistent with those rules.” He said—and this is just a few days ago—that the Geneva Conventions did not apply precisely.

Secretary CAMBONE. Yes, sir.

Senator LEVIN. You, this morning, said, again, the Geneva Conventions apply to our activities in Iraq.

Secretary CAMBONE. In Iraq.

Senator LEVIN. But not precisely?

Secretary CAMBONE. No. Sir, I think what—let me tell you what the facts are. The Geneva Conventions apply in Iraq.

Senator LEVIN. Precisely?

Secretary CAMBONE. Precisely.

Senator LEVIN. Do the—

Secretary CAMBONE. They do not apply in the precise way that the Secretary was talking about in Guantanamo and the—

Senator LEVIN. He was—

Secretary CAMBONE.—unlawful combatants.

Senator LEVIN.—talking about Iraq. Let me cut you right off there. The whole interview here was about Iraq—

Secretary CAMBONE. And I—

Senator LEVIN.—and the conditions at that prison. That’s what this whole entire interview was about. It was on NBC. It was May 5, 2004. It was an interview about Iraq. Guantanamo is no longer the issue here. The Secretary said something he’s said elsewhere, and I’ve heard this with my own ears recently. He said that the Geneva Conventions apply not precisely, that prisoners are treated “consistent with, but not pursuant to.”

Now, he did say the other day and this is a quote: “The Geneva Conventions did not apply precisely.” Are you saying that the SECDEF misspoke on—

Secretary CAMBONE. I can't speak for the SECDEF. I can only tell you what my understanding is, Senator——

Senator LEVIN. You don't know what he meant by that?

Secretary CAMBONE. I can tell you what I understand, and that is that——

Senator LEVIN. No. Do you know what he meant——

Secretary CAMBONE.—the Geneva Conventions apply.

Senator LEVIN.—by that?

Secretary CAMBONE. Sir, I can't speak for the SECDEF on that issue. I'll——

Senator LEVIN. You've not talked to——

Secretary CAMBONE.—take the—I will take the question for the record, and I will ask him. I can't——

Senator LEVIN.—the May 5 interview.

[The information referred to follows:]



UNDER SECRETARY OF DEFENSE
5000 DEFENSE PENTAGON
WASHINGTON, DC 20301-5000

JUN 22 2004

Honorable John Warner
Chairman, Senate Armed Services Committee
United States Senate
Washington, D.C. 20510

Dear Mr. Chairman:

In a hearing before the Senate Armed Services Committee on May 11, 2004, Senator Levin asked me what the Secretary of Defense meant when he said, in an interview dated May 5, 2004 "The Geneva Conventions did not apply precisely" in Iraq.

I have discussed this with the Secretary. He confirmed that the Geneva Conventions have always applied to the war in Iraq. He told me that if he said that the Conventions did not apply precisely he could have been talking only about their application with respect to al Qaeda and Taliban fighters and their detention in Afghanistan or Guantanamo.

I have reviewed the transcript of the interview to which Senator Levin referred in his question. The context of the Secretary's statement was a reply to a question incorporating a quotation from a Washington Post editorial of that morning:

Q: Let me read you something from the Washington Post in their editorial this morning. It says, quote, "A pattern of arrogant disregard for the protections of the Geneva Conventions or any other legal procedure has been set from the top by Mr. Rumsfeld and senior US commanders." What's your response to that?

The antecedent in the Post editorial for the alleged "pattern" is not Abu Ghraib but the conduct of U.S. military or intelligence forces "since the beginning of the war on terrorism." Thus, the context of the question was not Iraq, but rather the war on terrorism and the treatment of al Qaeda and the Taliban.

With that context in mind, the Secretary replied as follows:

A: Well, it's not accurate. The fact of the matter is that from the very outset, the decision was made by the government of the United States that the people detained would not be treated in a manner that was – (correction.) The decision was made that the Geneva Conventions did not apply precisely but that every individual would be treated as though the Geneva Conventions did apply. And as a result, the provisions of the Geneva Conventions were the basic rules under which all people were detained. So it would not be accurate to say what that editorial said.

That the interviewer understood Guantanamo and Afghanistan to be the context of the Secretary's answer is made clear by the very next question in which the Secretary is asked about statements he made in February 2002 concerning the Geneva Conventions, al Qaeda and the Taliban. As you know, the President directed in February 2002 that U.S. Armed Forces shall treat al Qaeda and Taliban detainees humanely and, to the extent appropriate and consistent with military necessity, in a manner consistent with the principles of the Geneva Conventions.

Sincerely,

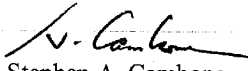

Stephen A. Cambone

cc: Senator Levin
Ranking Minority Member

Senator LEVIN. Thank you.

Chairman WARNER. Thank you very much, Senator Levin.

I think, at this juncture, Secretary Cambone said the question of the utilization of dogs and other things were at the command level. Can you speak to that response to that important question?

General SMITH. Sir, I can. The rule on dogs, that I'm aware of, is that they can patrol in the areas, but they have to be muzzled at all times.

Chairman WARNER. Have you examined the exact language that your command promulgated down to these prisons?

General SMITH. Sir, I have the Army techniques that are authorized, which is what they live by.

Chairman WARNER. All right. We have to clarify this. Secretary Cambone said it came from your command, so I ask you to focus on it and provide it for the committee.

[The information referred to follows:]

[Deleted.]

Senator McCain?

Senator MCCAIN. Thank you.

Senator MCCAIN. General Taguba, I want to thank you for your excellent report, and I think it's been very helpful to this committee, as well as to the American people.

General Miller—first of all, we know that the detainees at Guantanamo Bay are not subject to the Geneva Conventions because they're al Qaeda—at least those that are al Qaeda—and, therefore, being terrorists, they are not subject to the Geneva Conventions for the treatment of prisoners of war. I don't disagree with that assessment, and I don't think you do, either. Do you?

General TAGUBA. Yes, sir, no.

Senator MCCAIN. Yet General Miller was quoted in your report, when he arrived in Iraq—I believe Secretary Cambone was one of those who urged his transfer there—that he wanted to “Gitmo-ize” the treatment of prisoners in—throughout Iraq, including Abu Ghraib prison. What do you make of that statement?

General TAGUBA. Sir, I'd defer that to General Miller, sir. But, for the record, I've never been to Guantanamo. I'm only knowledgeable of my experience and my observations at Abu Ghraib, which is a detention operation, along with the other detention operations under the command and control of the 800 MP Brigade, as under combat conditions, separate and distinct of what I consider to be a sterile environment in Cuba.

Senator MCCAIN. But you found, clearly in your report, violations of the rules for the treatment—Geneva Conventions for the treatment of prisoners of war, right?

General TAGUBA. Yes, sir.

Senator MCCAIN. Including moving prisoners around to avoid ICRC inspections?

General TAGUBA. Yes, sir. That was conveyed to us by those that we interviewed, and comments that we assessed in the written statements.

Senator MCCAIN. In your report, General Karpinski says that General Sanchez said that in the case of problems in the prison—there was uprising and riot and escape—an American, I believe, was killed—that they should use lethal means immediately, and not non-lethal means to start with. Isn't that according to your report?

General TAGUBA. Yes, sir. They changed their rules of engagement (ROE), I believe, four times, to use lethal and then to—non-lethal to lethal force based on the levels of the events. I believe the last time they changed the ROE, sir, was in November of last year. That's contained in one of the annexes that we have.

Senator MCCAIN. In your judgment, were these abuses a result of an overall military or intelligence policy to “soften up” detainees for interrogation?

General TAGUBA. Sir, we did not gain any evidence where it was an overall MI policy of the sort. I think it was a matter of soldiers, with their interaction with MI personnel, who they perceived or thought to be competent authority that were giving them—or influencing their actions to set the conditions for successful interrogations operations.

Senator MCCAIN. According to your report, these abuses were very widespread, correct?

General TAGUBA. Sir, the manner by which we conducted our investigation and collected evidence was that they were between mid-to late-October, and as late as December, perhaps early January.

Senator MCCAIN. Mr. Cambone, the media report that complaints were made by Ambassador Bremer and Secretary Powell concerning the treatment of prisoners in Iraq, do you know anything about that?

Secretary CAMBONE. No, sir, I am not aware of those complaints.

Senator MCCAIN. In your opinion—well, maybe I'd better ask General Taguba—how far up the chain of command did awareness of these ongoing abuses—let me ask this.

When someone says that they're going to "Gitmo-ize" a prison, wouldn't a subordinate think, "We're going to change the rules"?

General TAGUBA. Sir, I'd rather not speculate on that. I don't exactly know what General Miller meant by "Gitmo-izing" Abu Ghraib because it's a different situation there.

Senator MCCAIN. I think it's pretty obvious, but I thank you for your testimony and your report.

Tell me, again, about your view of General Karpinski's role in this. She says that she was excluded from certain parts of the prison and certain areas where some of these abuses took place. Do you have anything on that?

General TAGUBA. Sir, I disagree with that.

Senator MCCAIN. You agree or disagree?

General TAGUBA. I disagree with the fact that she was excluded from certain areas of the prison. I believe, in my interview of her, she was still in charge of detention operations in-theater, and it's hard for me to believe that she would be excluded from any of those facilities, or even portions of those facilities.

Senator MCCAIN. What evidence did you find that these individuals received any training in the Geneva Conventions for the treatment of prisoners of war?

General TAGUBA. Sir, the evidence that we gathered were training records from the training that they received at the mobilization station and home station, their mission essential-tasks list that they developed to prepare them for deployment, that sort of thing. Several of these soldiers intimated to us—at least conveyed to us—that they were never trained on internment or resettlement operations. But as far as I was concerned, sir, they were—their leaders should have, could have, provided the necessary resources to which they are expected to do so in training their soldiers.

Senator MCCAIN. But they did not receive it.

General TAGUBA. No, sir.

Senator MCCAIN. Mr. Cambone states that they did, and the SECDEF states they did. I thank you, General.

Thank you very much, Mr. Chairman.

Secretary CAMBONE. Mr. Chairman, could I just be a little more clear with Senator McCain?

Chairman WARNER. Yes, indeed.

Secretary CAMBONE. You asked if I was aware of concerns expressed by Ambassador Bremer and the Secretary of State, and I assumed you meant specifically on these cases.

Senator MCCAIN. No, I—

Secretary CAMBONE. I mean, that's what I intended to answer.

Senator MCCAIN.—on the treatment of prisoners of war.

Secretary CAMBONE. Yes, let me give you a broader answer, which is—

Senator MCCAIN. Thank you.

Secretary CAMBONE.—Ambassador Bremer had been concerned about the number of people who were in custody, and was anxious to see them move through the system and released as rapidly as possible, as was Secretary Powell.

Senator MCCAIN. But my question was—

Secretary CAMBONE.—on the broad question—

Senator MCCAIN.—but my question was—and I'm sorry to interrupt; my time's expired—

Secretary CAMBONE. Forgive me.

Senator MCCAIN.—were you aware of the complaints about treatment of prisoners of war made by Ambassador Bremer?

Secretary CAMBONE. Per se, in that sense, no. That he was worried about prisoners of war, that I knew.

Senator MCCAIN. Thank you.

Thank you, Mr. Chairman.

General SMITH. Sir, could I also add that I have all the standard operating procedures (SOP) here for Gitmo. In every case, it is very specifically and clearly written that the humane treatment of prisoners is first and foremost, and inhumane treatment of detainees is never justified. It is all in the spirit of the Geneva Conventions.

Senator MCCAIN. I thank you. But clearly there's a difference between adherence to the Geneva Conventions for treatment of prisoners of war—

General SMITH. Yes, sir, but we were operating under the Geneva Conventions in Iraq. We clearly understood that.

Senator MCCAIN. I thank you.

Thank you, sir.

Chairman WARNER. Now, those applied to the prison in Iraq.

General SMITH. Sir, when he went over there, and he talked—

Chairman WARNER. When who went?

General SMITH. When General Miller went over there, and he spoke and addressed this with each of the commanders, he gave them the SOP that they were using at Gitmo to use as an example on how they should generate their own operating procedures.

Chairman WARNER. That included the phraseology to—

General SMITH. Exactly, sir. I just read it to you.

Sir, may I also just mention, on your question on promulgation of policy, the policy regarding dogs was established and put out by CJTF-7 on October 12, 2003, and it specifically says that interrogators must ensure the safety of security internees, and approaches must in no way endanger them. Interrogators will ensure that security internees are allowed adequate sleep, that diets—et cetera, et cetera—and then it says, "Should military working dogs be present during interrogations, they will be muzzled and under control of a handler at all times to ensure safety."

So General Sanchez, through those things, very specifically addressed what was allowed in the interrogation room and what was

not allowed and those things that required his approval, such as segregation from the population in excess of 30 days.

Chairman WARNER. Can you throw any light, then, on where this thing broke down, given that he started in the proper way?

General SMITH. Sir, given the guidance that was put out there, I can't. I have to agree with General Taguba's assessment of it, in that these rules and regulations were out there, and, somewhere in the leadership chain execution and implementation of these policies broke down.

Chairman WARNER. Is CENTCOM trying to find out where that happened?

General SMITH. Absolutely, sir.

Chairman WARNER. All right. Thank you.

Senator Kennedy.

Senator KENNEDY. Thank you, Mr. Chairman.

General Taguba, I want to join others in commending you and thank you for the service to this country.

Secretary Cambone, I hope when you have a chance to read through the 2004 report, which, according to the ICRC, was given to Paul Bremer, General Sanchez, and the U.S. Permanent Mission in Geneva, according to Christopher Girard, who's from the ICRC, it talks about the ICRC collected allegations of ill treatment following the capture that took place in Baghdad, Basra, Ramadi, and Tikrit.

General TAGUBA. Yes, sir.

Senator KENNEDY. It isn't only focused on this one prison camp, but lists the others, as well. I think we have to be aware of that.

General TAGUBA. Yes, sir.

Senator KENNEDY. Now, let me just go quickly to this report. Newsweek Magazine reports that, since September 11, Secretary Rumsfeld has insisted on personally signing off on the harsher methods used to squeeze suspected terrorists held at U.S. prison in Guantanamo Bay, Cuba. He's approved such tactics as the use of stress positions, stripping of detainees naked, prolonged sleep deprivation. Have you advised Secretary Rumsfeld on these issues? What other officials of the DOD have participated in these decisions?

Secretary CAMBONE. Sir, I can answer—

Senator KENNEDY. Has the General Counsel been involved in—

Secretary CAMBONE. Yes, sir.

Senator KENNEDY.—giving advice?

Secretary CAMBONE. Yes, sir.

Senator KENNEDY. He's been involved?

Secretary CAMBONE. If I may, sir.

Senator KENNEDY. Yes.

Secretary CAMBONE. With the permission of the chair and yourself, the SECDEF has a deep regard for the well-being of those being held in Guantanamo and their well-being and their care. Therefore, any procedure, which is of the type that General Smith suggested, which are in the approved rules, but are harsh, he has withheld to his approval first.

Second, when the issue of how these prisoners, detainees, in Guantanamo were to be treated—there was convened, under the GC, the General Counsel of the Department, a working group

whose objective it was to work through all of these issues. So that matrix that has been reported is the product of that effort.

Senator KENNEDY. All right. Let me—because my time is short—has the SECDEF—so he has, evidently, approved these kinds of things.

Secretary CAMBONE. I don't know in detail, sir, but those that he—there is a list that he has approved.

Senator KENNEDY. He has approved. What about on Iraq? Has he approved signing off on harsher methods of interrogation in Iraq?

Secretary CAMBONE. Again, sir, no. That, as General Smith said, is CJTF-7 promulgation.

Senator KENNEDY. If not, who—has someone had that authority in Iraq?

Secretary CAMBONE. If there is anything that exceeds General Sanchez's direction, he is, as I understand it, to sign off on that exception.

Senator KENNEDY. So he has the authority, General Sanchez. Do you know whether he's used that or not?

Secretary CAMBONE. General Smith?

General SMITH. Sir, he—

Senator KENNEDY. Just quickly.

General SMITH. Yes, sir. Just in that policy that I told you, where separation of greater than 30 days—he would be the approval authority. To the best of my knowledge, he has not used anything beyond that.

Senator KENNEDY. Let me ask you, Secretary Cambone, about "rendering." There are a number of reports about detainees in U.S. custody, U.S. intelligence officials being transferred for interrogations to governments that routinely torture prisoners. In December 2002, The Washington Post stated, "Detainees that refuse to cooperate with Americans have been rendered to foreign intelligence services"—Saudi Arabia, Jordan, Morocco, Syria, and other countries. Can you assure the committee that the administration is fully complying with all of the legal requirements, and that all reports of U.S. officials engaging in the practice of rendering are false?

Secretary CAMBONE. Sir, to the best of my knowledge, that is a true statement.

Senator KENNEDY. We are not—we have not—your statement, sworn statement, now—to your knowledge, the United States has not been involved in any rendering, any turning over of any personnel to any other country.

Secretary CAMBONE. No. No, you said that they were turned over for torture and misbehavior—mistreatment. We have returned, for example, individuals to the United Kingdom. There may be three or four of them that have been returned from Gitmo.

Senator KENNEDY. Have you turned over, to your knowledge, any suspects to Saudi Arabia, Jordan, Morocco, or Syria to gather information?

Secretary CAMBONE. From those people in DOD custody, not that I am aware of, sir.

Senator KENNEDY. Well, you would know—

Secretary CAMBONE. I am not aware of any that have been transferred for that purpose. If I—

Senator KENNEDY. Well, for—

Secretary CAMBONE.—if there are—

Senator KENNEDY.—for any other purpose?

Secretary CAMBONE. If there are, I will come back to you and tell you. As best I know, there are not any persons under our custody that have been transferred.

Senator KENNEDY. Do the interrogators for MI, the CIA, and also the contract intelligence—do they all have identical rules and regulations, in terms of interrogating the detainees or prisoners of war or combatants, or is there any distinction among the three?

Secretary CAMBONE. Within Iraq, the rules of the Geneva Conventions apply. So, therefore, the rules—

Senator KENNEDY. I was not—that isn't my question. That's not my question.

Secretary CAMBONE. Sir—

Senator KENNEDY. My question is, do they have different kinds of rules of questioning? Do each of those services have rules? If they do have rules, how are they different?

Secretary CAMBONE. I can speak for the DOD contractor and military personnel, and those rules are the same. The people we hire—

Senator KENNEDY. Identical.

Secretary CAMBONE.—the people we hire, in most cases, are required to have had that training in the military in order to become interrogators.

Senator KENNEDY. They are bound by the same set—

Secretary CAMBONE. Yes, sir.

Senator KENNEDY. So your testimony is, the private contractors, MI, and the military interrogators all operate at the same—and the CIA—all operate with the same rules of interrogation.

Secretary CAMBONE. I can only speak for the last, the military, inside of Iraq, sir.

Senator KENNEDY. You're going to provide those rules to us?

Secretary CAMBONE. I can do that.

[The information referred to follows:]

[Deleted.]

Senator KENNEDY. Let me just ask you, finally, in the opinion of General Taguba, the setting of conditions for favorable interrogation is not authorized or consistent with Army regulations. You seem to reach a different conclusion in your testimony today.

Secretary CAMBONE. Yes, sir.

Senator KENNEDY. Do you agree you and General Taguba differ on that issue?

Secretary CAMBONE. Yes, sir. We do, and in this sense—

Senator KENNEDY. I think it's important that we understand, when we're talking about the abuses that are taking place with the MP, and you have two entirely different kinds of viewpoints on this issue—how in the world are the MP that are supposed to implement going to be able to get it straight, particularly when you have General Miller there that is following what you believe, Mr. Secretary?

Secretary CAMBONE. Yes, sir.

Senator KENNEDY. How are we—how do you expect the MPs to get it straight if we have a difference between the two of you?

Secretary CAMBONE. Let me try and explain it. As far as I understand it, there is doctrine relative to the MP which gives them the responsibility for conveying to the interrogators the attitudes of those who are going to be interrogated—their disposition, who they've been talking to, and so forth—and as the interrogators, in turn, under doctrine, Army doctrine, ask the MP those kinds of questions. So there is designed in the system a collaborative approach with respect to gaining that information.

With respect to the issue of “Gitmo-izing,” if I may return to that, Senator Kennedy, let's go back to the conditions that were in Abu Ghraib. They were disorderly, as the General has pointed out. The notion, it seems to me, that General Miller had was that order needed to be established in the processes and procedures.

Senator KENNEDY. Just to finish, because my time is up—General Taguba, why do you believe that there should be a separation between the MP and MI officers?

General TAGUBA. Sir, there's a baseline that we use as a reference, which is Army Regulation 190–8, which is a multi-service regulation, establishing the policy of an executive agency for detention operations. In there it enumerates, in paragraph 1–5, the general policy and the treatment of not just EPWs, but civilian internees, retained personnel, and other detainees. That's the baseline that we use. We also use the MP's doctrine on detention operations, which is Field Manual 3–19.40. We further refer to the interrogations operations doctrine used by the MI, which is Field Manual 34–52.

Chairman WARNER. Thank you very much, Senator.

Senator Inhofe.

Senator INHOFE. Thank you, Mr. Chairman.

First of all, I regret I wasn't here on Friday. I was unable to be here. But maybe it's better that I wasn't, because as I watch this outrage, this outrage everyone seems to have about the treatment of these prisoners, I was, I have to say—and I'm probably not the only one up at this table that is more outraged by the outrage than we are by the treatment. The idea that these prisoners—they're not there for traffic violations. If they're in cell block 1A or 1B, these prisoners, they're murderers, they're terrorists, they're insurgents. Many of them probably have American blood on their hands. Here we're so concerned about the treatment of those individuals.

I hasten to say, yes, there are seven bad guys and gals that didn't do what they should have done. They were misguided and, I think, maybe even perverted. The things that they did have to be punished. They're being punished. They're being tried right now, and that's all taking place.

But I'm also outraged by the press and the politicians and the political agendas that are being served by this. I say “political agendas” because that's actually what is happening. I would share with my colleagues a solicitation that was made. I'm going to read the first two sentences. “Over the past week, we've all been shocked by the pictures from Abu Ghraib prison in Iraq, but we have also been appalled at the slow and inept response by President Bush, which has further undermined America's credibility.” It

goes on to demand that George Bush fire Donald Rumsfeld, and then it goes on to a timeline, a chronology. At the very last—and they say, “a solicitation for contributions.” I don’t recall this ever having happened before in history.

Mr. Chairman, I ask unanimous consent that this solicitation be made a part of the record at this point.

Chairman WARNER. Without objection.

[The information referred to follows:]



Dear Friend,

Over the past week we have all been shocked by the pictures from the Abu Ghraib prison in Iraq. But we have also been appalled at the slow and inept response by President Bush, which has further undermined America's credibility in the world and created new dangers for Americans in Iraq. George Bush **must fire Donald Rumsfeld**. But that is only a first step towards taking responsibility for his administration's failures in Iraq.

**Donald Rumsfeld
must resign.**

SIGN OUR PETITION

John Kerry has called on Donald Rumsfeld to resign, and today we're asking you to support him by adding your name to the call for Rumsfeld to resign here:

<http://www.johnkerry.com/petition/rumsfeld.php>

Help us show that America supports John Kerry in calling for Rumsfeld to resign. If 50,000 people sign this petition, that is a strong statement that will be recognized in the media – and by the Bush-Cheney campaign. Help us get to 50,000 signers by today by forwarding this email to your friends and family.

The events of the last week are a stark reminder of the stakes in this Presidential election. John Kerry's remarks yesterday painted a striking contrast to President Bush's evasion of responsibility,

"As president, I will not be the last to know what is going on in my command," Kerry said. "I will demand accountability for those who serve and I will take responsibility for their actions. And I will do everything that I can in my power to repair the damage that this has caused to America, to our standing in the world, and to the ideals for which we stand... Today, I have a message for the men and women of our armed forces. As commander in chief, I will honor your commitment and I will take responsibility for the bad as well as the good."

Show George Bush and show the media that you support John Kerry's stand: Donald Rumsfeld **MUST** resign immediately. To sign please click here:

<http://www.johnkerry.com/petition/rumsfeld.php>

Obviously this is one of the most important petitions we will send out in the course of this campaign. Please forward this petition to **EVERYONE** in your address book and get the word out.

Thank you,

Mary Beth Cahill
Campaign Manager, John Kerry for President

TIMELINE: What was known, and when.

Fall 2003 Bremer repeatedly raises issue of prison conditions with Rumsfeld and the President's inner circle according to LA Times: "Bremer repeatedly raised the issue of prison conditions as early as last fall – both in one-on-one meetings with Rumsfeld and other administration leaders, and in group meetings with the president's inner circle on national security. Officials described Bremer as 'kicking and screaming' about the need to release thousands of uncharged prisoners and improve conditions for those who remained." (Washington Post, Graham, 5/7/04)

November 5, 2003 Maj. Gen. Donald J. Ryder files report concluding that there were potential human rights, training, and manpower issues – system wide – that needed immediate attention. Discussed serious concerns about tension between missions of the military police

assigned to guard prisoners and intelligence teams who interrogate them. (New Yorker Magazine, Hersh, 5/5/04)

January 2004 Rumsfeld learns of photographs showing prisoner abuse according to the Washington Post: "...Rumsfeld has known of the photographs since January, when they came to the attention of U.S. commanders in Iraq, he had not seen them, and he was not aware that CBS was about to air them until just hours before they were broadcast last week." (Washington Post, Graham, 5/7/04)

Mid-January, 2004 Bush told about the photo of abuse according to the Washington Post: "Marine Gen. Peter Pace...said Wednesday on CBS's "Early Show" that beginning in mid-January, everyone "up the chain of command . . . was kept apprised orally of the ongoing investigation." Asked if Bush "was well aware of the situation," Pace replied: "Yes."" (Washington Post, Allen, 5/7/04)

Late February 2004 Major General Antonio M. Taguba issues 53-page report concluding that between October and December 2003 there were numerous instances of "sadistic, blatant and wanton criminal abuses" at Abu Ghraib. Report was not meant for public release. (New York, Hersh, 5/5/04 and LA Times, McDonnell, 5/3/04)

March 2004 Six enlisted personnel charged with prisoner abuse at Abu Ghraib. One is court marshaled. (AP, Burns, 5/3/04)

Mid-April, 2004 Military learns CBS has pictures of prisoner abuse in Iraq. General Abizaid and General Myers ask CBS to post-pone broadcast of the photos. (NY Times, Schmitt, 5/4/04)

April 28, 2004

- Graphic photos of abuse of Iraqi prisoners are shown on CBS 60 Minutes 2. (AP, Crary, 4/28/04)
- Rumsfeld provides classified briefing to Congressional leaders on situation in Iraq, fails to mention that photos of Iraqi abuse victims will be aired that evening on television. (Senate Armed Services Committee Testimony, Levin, 5/7/04)
- May 3, 2004 Spokesman McClellan says that Bush still hasn't seen or been briefed on the Taguba report. (WH Briefing, McClellan, 5/3/04).

May 4, 2004

- Rumsfeld says he disagrees with critics who have said the Pentagon moved too slowly. Defense Department officials have moved correctly and efficiently, he said. "The system works," he said. "The system works." Admitted he had not read the whole Taguba report or seen the photos. (DoD Briefing, Rumsfeld, 5/4/04)
- Military discloses Army has conducted 30 criminal investigations into misconduct by American captors in Iraq and Afghanistan, including 10 cases of suspicious death, 10 cases of abuse, and two deaths of Iraqis already determined to have been criminal homicides. (NY Times, Neilan, 5/5/04)
- General George Casey, Army's Vice-Chief of Staff, refers to a "complete breakdown in discipline." (NY Times, Reuters wire, 5/5/04)

Senator INHOFE. Mr. Chairman, I also have to say, when we talk about the treatment of these prisoners, that I would guess that these prisoners wake up every morning thanking Allah that Saddam Hussein is not in charge of these prisons. When he was in charge, they would take electric drills and drill holes through hands. They would cut their tongues out. They would cut their ears off. We've seen accounts of lowering their bodies into vats of acid. All these things were taking place. This was the type of treatment that they had.

I would want everyone to get this and read it. This is a documentary of the Iraqi Special Report. It talks about the unspeakable

acts of mass murder, unspeakable acts of torture, unspeakable acts of mutilation, the murdering of kids—lining up 312 little kids, under 12 years old, and executing them—and then, of course, what they do to Americans, too.

There's one story in here that was in the—I think it was The New York Times—yes, on June 2. I suggest everyone take that—get that and read it. It's about one of the prisoners who did escape as they were marched out there, blindfolded, and put before mass graves, and they mowed them down, and they buried them. This man was buried alive, and he clawed his way out and was able to tell his story.

I ask, Mr. Chairman, at this point in the record, that this account of the brutality of Saddam Hussein be entered into the record, made a part of the record.

Chairman WARNER. Without objection, so ordered.

[The information referred to follows:]



September 29, 2003

Tales of Saddam's Brutality

The Iraqi people talk about mass graves and Saddam's crimes against humanity

The cruelty of Saddam's regime is evident in its brutality toward Iraqi citizens. Mass grave sites across Iraq provide further evidence of Saddam's atrocities. Below, the Iraqi people share their stories of brutality, torture, fear, and death.

U.S. Marine Corps photo by
Lance Col. Christopher Graham
Remains found at mass gravesites, located near a
farm on the outskirts of Al Mahawil, Iraq, May 7, 2003.

For more personal stories of life after Saddam, visit [Liberation Update](#).

For more information on Coalition assistance to protect mass graves, [click here](#).

"The prison was a terrible, miserable place. I saw my relatives being tortured. One time, they buried my uncle in the sand up to his neck and left him in the heat. It was awful to watch. But the worst day was when they came for my father. Even then, I knew I would never see him again. I could feel it."

— **Khairiya Hatim, Iraqi town councilor who was imprisoned with her family because of their allegiance to a banned opposition party, Sunday Telegraph (London), September 28, 2003**

"When Saddam Hussein's government went on an anti-inflation tear in 1992, it rounded up, tried and executed 42 food merchants in one day, including Tabra's father, the wealthy patriarch of a well-known trading family.

"Whenever there was a merchant, a famous name in any sector, the old regime tried to stop them," Omar Tabra [Iraqi food merchant] said. "They did it by killing."

— **Bill Glauber, Chicago Tribune, September 27, 2003**

"Most afternoons, among the market stalls leading to the old city of Najaf young men set up TV sets in the street showing grotesque scenes of cruelty. Handcuffed prisoners are executed with sticks of dynamite shoved into their pockets. Screaming men plead for their lives as they are beaten by Saddam Hussein's secret police. Crimson fragments of bodies lie in the street, moments after a huge explosion, to the soundtrack of an Arab lament. The crowds gather round. People mutter and shake their heads. Then they queue to pay 1,000 Iraqi dinars (about 33p) [50 cents] for laser discs containing footage of the appalling scenes. These are the atrocity discs of Iraq, a booming mini-industry in a country still stricken by the consequences of the war. They are produced in home factories, with the simplest computer equipment."

— **The London Times, September 20, 2003**

"The day after the liberation, my aunt put out a black banner—an Arab mourning ritual—with the names of all her relatives who had been murdered by the regime on it. And she looked down her street, and there were black banners on almost every house. On some houses it looks like a long shopping list. She said to her neighbour, "You too?" Under Saddam it was a crime to mourn people killed by the regime—it made you seem suspicious too. Everyone was suffering terribly, but they were suffering alone. They just didn't know that everyone else was hating it too."

— **Yasser Alaskary, co-founder of Iraqi Prospect Organisation, an Iraqi freedom group, The Independent (London), September 18, 2003**

"Virtually every athlete at the club has physical or mental scars inflicted by Saddam Hussein's older son, Uday, who took control of Iraq's

Photo by Thomas Hartwell
Aweda Abed Al-Amer, 48, grieves over two members

Olympic Committee in 1984 and began a terrifying campaign of torture and humiliation. Many fled the country, including Mr. [Ahmed] Samarra'i....

of her family found in a mass grave in Musayib, 75 KM SW of Baghdad. She lost 5 members of her family including her husband, son and 3 nephews after an uprising against the Iraqi government in 1981. The bodies wrapped in linen shrouds are being held in a makeshift morgue in a youth center for possible identification.

"The system of the regime started in primary school,' said Mr. Samarra'i, who defected on a trip to Switzerland in 1983 and returned here after the war. 'It was exactly like the Nazis in the 30's.'...

"Uday played hell with sports,' said Immanuel Baba Dano, a revered figure in Iraq who was coach of the national soccer team for most of the last three decades....

"Some athletes were humiliated, he said. Others were smeared with feces and jailed. Some were placed in a sarcophagus with nails pointed inward so that they would be punctured and suffocated, he said. At least a few were set in front of wild dogs to be torn to pieces. How many were executed is still not clear.

"Nobody knew what was in his mind,' Mr. Dano said. 'But there was no pity.'"
-- **The New York Times, August 17, 2003**

"We smelled something rotten, and when we breathed in, we couldn't breathe out. The sky was full of smoke, and someone said it was chemicals. People started crying and running toward the mountains. I was burning and I became blind, but someone led me out. After walking for two days, we reached Iran.' [Wais Abdel] Qadr was the only member of his family to survive the gassing of Halabja by the Iraqi military on March 16, 1988."
-- **The Washington Post, August 7, 2003**

"Freed in April after 13 years in prison, [Dr. Ibrahim] Basri [Saddam's former physician] is now reaching out to register and help as many victims of the regime as he can find. They stream to a clinic attached to his house, a sad collection of former political prisoners, relatives of the executed, and maimed men who cannot work because they lost an arm, an ear, or a foot to the torturer's knife. 'All the time in prison, I think, "What can I do to help these people?"' he said. ... 'For the first five years, he put me in a cell by myself, 2 meters by 2 1/2 meters, where I didn't know if it was day or night. I was so dirty with lice. There were cockroaches in my mouth at night. And they came to beat you in the morning and at night for nothing, nothing.' Once, he continued, the guards beat him in front of 300 inmates until they broke his legs. 'I never said, "Mercy," I just said, "Iraq.'"
-- **The Boston Globe, August 7, 2003**

Photo by Thomas Hartwell
Iraqis search for their relatives and friends among victims found in a mass grave in Musayib, 75 KM SW of Baghdad. The victims are thought to be from among some 2,000 persons reported missing after the 1991 uprising against the Iraqi government. The bodies, wrapped in linen shrouds are being held in a makeshift morgue in a youth center.

"The nightmares persist, even years later, as Ehab Al Deen cannot shake the memories of torment from his summer camp with 'Saddam's Lion Cubs.'

"Like thousands of Iraqi teens, Al Deen vividly recalls long marches in oppressive heat, being slapped by military trainers for not following orders and spending nights in fields listening to the howls of wolves.

"The camps culminated each August with a ceremony in which the youths were videotaped in the Iraqi fighter tradition of ripping a dog's flesh with their teeth.

"The dogs were already dead,' said Al Deen, 18, who attended the camp in 1998 and still recalls the bitter taste. 'It was horrible.' ...

"They were mostly disenfranchised children from poor neighborhoods or sons of Baath Party members recruited by teachers during the school year. ...

"But once they arrived at the two military camps on the outskirts of Baghdad, the youths found hard work and mostly empty promises. ...

"I was so scared,' said Al Deen, who was 13 when he went to the camp in 1998. 'We cried for hours.'"
-- **Chicago Tribune, August 3, 2003**

"The bodyguard says he was disgusted by Uday's activities-he points to a floor-to-ceiling cage in the corner of the club's kitchen where he says monkeys were kept for Uday because he liked to have the animals watch him when he was deflowering virgins. ... It was his to make the singers who entertained Uday at the Boat Club gulp down a liter and a half of a 'cocktail,' a combination of 90-proof alcohol often with some drugs thrown in. ...

"I would line up all the entertainment against that wall," the bodyguard said, pointing to the side of the garage. "And I would take a stick. ... And I would say, "Drink, drink, you have 10 minutes." If any of them didn't drink, I hit them with a stick.' ... Then, if the singers still refused, they were given a 'street beating,' meaning that their faces were untouched but they were pummeled until they could hardly stand up. ...

"I always felt like I was the one who took the beatings because each shout of pain from the beaten person, I used to pray to God and ask God to punish me for what I was doing. But the person who took the beating did not know that if I didn't carry out the orders, I would take the same beating that he was getting."

-- Los Angeles Times, August 2, 2003

"Jailers often treated allegedly lagging players in ways certain to hurt, not improve, the athletes' performances on the field. After shaving their heads to humiliate them, athletes were hung upside down and the soles of their feet whipped. They were buried in hot sand up to their necks. Their fingers or ears were amputated. Electric shocks were applied to their skin. And, in the case of soccer players, they were forced to kick concrete balls."

-- USA TODAY, July 30, 2003

At only 22, Tareq, a defender, has been to prison five times. After a while, he recognized a pattern to the punishment.

"The first stage of the torture is the reception, when you are given a choice of which plastic cable you will be beaten with.

Then you are beaten 15 to 20 times. The reception is over. In the next stage, you are thrown into knee-deep sewer water and told to swim," he says. Tareq was dragged bare-chested across hot asphalt. Made to run barefoot over broken glass and gravel. When it was time to leave, he says, "The farewell party is a beating."

-- USA TODAY, July 30, 2003

Photo by Thomas Hartwell
Iraqi workers dig for the remains of Iraqis from a mass grave in Musayib, 75 KM SW of Baghdad. The victims are thought to be from among some 2,000 persons reported missing after the 1991 uprising against the Iraqi government.

Tareq recalls how his team was invited to pose for pictures with Uday. At 6-5, Tareq towered over Uday. "The next day, I was taken and flogged 20 times" for being taller, says Tareq, who plans to leave Iraq soon to play professionally in Germany or Scandinavia.

-- USA TODAY, July 30, 2003

"Ahmad was Uday's chief executioner. Last week, as Iraqis celebrated the death of his former boss and his equally savage younger brother Qusay, he nervously revealed a hideous story. His instructions that day in 1999 were to arrest the two 19-year-olds on the campus of Baghdad's Academy of Fine Arts and deliver them at Radwaniyah. On arrival at the sprawling compound, he was directed to a farm where he found a large cage. Inside, two lions waited. They belonged to Uday. Guards took the two young men from the car and opened the cage door. One of the victims collapsed in terror as they were dragged, screaming and shouting, to meet their fate. Ahmad watched as the students frantically looked for a way of escape. There was none. The lions pounced. 'I saw the head of the first student literally come off his body with the first bite and then had to stand and watch the animals devour the two young men. By the time they were finished there was little left but for the bones and bits and pieces of unwanted flesh,' he recalled last week."

-- Sunday Times, London, July 27, 2003

One of the condemned women was pregnant. This presented a problem, said Ahmad, because under religious law a pregnant woman should at least be allowed to finish her term and deliver the baby before being executed. 'She was several months' pregnant,' he said. 'The doctor had verified it, she had said so and we could see her swollen stomach. She was taken in and out three times - everyone was unsure what to do with her.' Telephone calls were made to Uday by his representative. As they waited, the woman sobbed and begged for mercy for her unborn child. On the third telephone call the order was given to go ahead with her execution. 'At that the woman was beheaded - and knowing she was pregnant, I felt sick in the stomach and wished for Allah to open up the

ground and swallow everyone there including myself,' said Ahmad.
 -- **Sunday Times, London, July 27, 2003**

"They put me in a cell just 1m by 1.5m, painted completely red with no windows and lots of tiny stones on the floor and told me to count them. It did not matter what number you said it would be wrong. If I said 2000, they would say no, it's 2001 and beat me 10 times. Then they put me inside a circle and told me to run round and round for nine hours. After that they threw me on the hot pavement and a fat guard sat on my chest. Then they pulled me along by my ankles so that my back was streaming with blood.

"Another time they drew a bicycle on the wall and told me to ride it. They threw me in foul dirty water and said you must swim, then they kept pushing me under with a stick forcing me to drink.

"Once they told us we had to catch 10 flies during the night and 10 mosquitoes during the day or you would be tortured more. This was impossible so you had to catch the mosquitoes at night and hold them till daytime and vice versa with the flies. Then they would ask which is male and which is female. Whatever you said it would be vice versa."

-- **Sunday Times, London, July 27, 2003**

"I have never spoken of this before because I was afraid for my family," said Faig. "But now they are gone, and we are finally free to speak of such things."
 -- **Sunday Times, London, July 27, 2003**

"When I was in Iraq a doctor from Basra told me that, after being jailed by the police some years ago, he refused to tell his inquisitors whatever it was they wanted to hear. Instead of beating him, he told me, they brought in his 3-month-old daughter. The interrogator tore the screaming infant's eye out. When the desired answers were still not forthcoming, the questioner hurled the little girl against the concrete wall and smashed her skull."
 -- **The New York Times, July 26, 2003**

"After games, they called me from Oda's office," Mahmud said. "They would say: 'This player, this player, this player.' I would organize the players. They would sit in a room. Someone would come and take them, jail them."

"If he would find any small mistake, he would directly punish me," said Laith Hussein, captain since 1996 of the Iraqi national soccer team, recalling "10 or 12" times that he was jailed over the years.
 -- **Los Angeles Times, July 25, 2003**

Iraqi exiles agreed that Uday Hussein, the eldest of five children, personified the government's random brutality. Human rights groups and Iraqi exiles accused him of routinely kidnapping women off the streets, raping and sometimes torturing them, and personally supervising the torture and humiliation of hundreds of prisoners. Such conduct earned him the title "Abu Sarhan," the Arabic term for "father of the wolf."
 -- **The New York Times, July 23, 2003**

"I remember once I was in the disco in the Al-Mansour hotel," said a former air force engineer, who asked to remain anonymous. "We were up there dancing with some Irish nurses. Then Qusay and his guys come in. I'm dancing with this nurse and suddenly Qusay is at my side. He just pulls back his jacket and shows me his gun. I said to the nurse, 'You can stay if you want but we're leaving.'"
 -- **Newsday (New York), July 23, 2003**

Photo by Thomas Hartwell
 Iraqi search for their relatives and friends among victims found in a mass grave in Musayib, 75 KM SW of Baghdad. The victims are thought to be from among some 2,000 persons reported missing after the 1991 uprising against the Iraqi government. The bodies wrapped in linen shrouds are being held in a makeshift morgue in a youth center.

"Contrary to what has been written, Uday was never married and he was obsessed with women. If he spotted a woman he fancied in the street or at a reception, he would send his henchmen to fetch her."

-- **Uday's former aide, Agence France Presse, July 22, 2003**

"Prisoners were often eliminated with a bullet to the head, but one witness told the London-based human rights group Indict that inmates were sometimes murdered by being dropped into shredding machines. Some prisoners went in headfirst and died quickly, while others were put in feet first and died screaming. The witness said that on at least one occasion, Qusai supervised shredding-machine murders."

-- **Associated Press, July 22, 2003**

"In the last room, where she was held for several hours, the door was locked. At sunset two men entered. She recalled they said they had to take routine security precautions in advance of a meeting with Uday Hussein. They slipped a black hood over her head and tied her hands behind her back. The anxiety, which had mounted through the day, flared into terror. She was taken down to a lower level in an elevator and then along a passageway that seemed narrow because of the way the two men bumped against her. She was pushed into a room and tied, spread-eagle, to a bed.

"All of this period, I didn't resist,' she said. 'But on the bed, I knew. I said, 'I am like your sister; please don't do this.' I started to beg. They said if our sister married an Indian and started a network against the government, we would kill her. I kept praying, calling for Jesus and the Virgin Mary. I prayed to Muhammad. They damned them all.'

"They raped me twice that first day,' she continued. 'I don't know the persons. Two of them. I couldn't see them. They kept raping for four days as well as I can remember. They took my honor.'

"Over the next seven months, Hanna said, she implicated people she had never heard of in a spy network she knew nothing about. She was routinely beaten and she said the Major, in a grotesque joke, kept three sticks on a wall hanging under the names Jesus, the prophet Muhammad and Imam Ali, whom Shiite Muslims believe is Muhammad's true heir. Whichever holy man a prisoner called out for determined which stick they were beaten with. The Major, she said, also routinely used electric shock and once set a police dog on her in a small room; the scar of the bite mark is still on her arm.

"One of his preferred forms of torture, she said, was to order the women to strip, then tie them to the tree trunk, and smear wet sugar on them so the dogs would terrorize them as they licked it off their bodies. Hanna also identified his superior at the academy."

-- **The Washington Post, July 21, 2003**

"Saddam's troops and Fedayeen first stormed through the region in armed helicopters in 1991- the helicopters that Norman Schwarzkopf allowed him to keep. One man says his son was hung for belonging to a Shiite political group. Another man says his father and uncle were hung in front of him when he was a 15-year-old. Entire families were slaughtered."

-- **The Wall Street Journal, July 21, 2003**

"Among them here are children of ages less than three - what was their guilt that they should be murdered?' Mr Amin said. 'Just because they were Kurds? Among them are old women with no teeth. What harm could they do? Saddam Hussein was nothing but a dictator and a killer.'

"Sunni Arab villager Ali Ibrahim said his friend Khalil Eid, then a 14-year-old shepherd, was one of the few local people to have had first-hand experience of the massacre. 'One day he came to this place with his sheep and some army vehicles came, and they told him to go far away because there would be shooting practice here,' Mr Ibrahim said. 'He went far off into the desert but later he sneaked back and heard the sound of firing and people screaming.' After the forces had driven away he came and saw they had leveled the ground. It's a disaster. It's a crime that cannot be described."

-- **The Age (Melbourne), July 17, 2003**

"That's when I realized this was no ordinary execution,' said the officer, a retired colonel from the Iraqi 2nd Army Corps who spoke on condition of anonymity.

"The government was using prisoners to test its chemical weapons.'

"He didn't have a mark on him, nothing,' Al-Hamid recalled bitterly. 'We were told not to touch him. We were told to bury him as fast as possible.' As for the Iraqi army intelligence officer who claims to have witnessed the test gassing of hundreds of prisoners at an open-air site in the desert near Jalula, which is about 80 miles northeast of Baghdad and 20 miles from the Iranian border, he asserted that the bodies he saw also bore no marks. 'It was like they were asleep,' he said with lingering awe."

-- Chicago Tribune, July 16, 2003

"You see, sir,' said Karim Jasim, an excavator brushing dirt off a skeleton at the al-Musayyib mass grave near Kerbala, 'there are two Iraqis; one above the ground, and another beneath it."

-- The Observer (London), July 6, 2003

"We'd raise their legs and place their feet into this sort of wooden frame and we would beat them on the soles of their feet,' said Abu Firaz, a former guard, describing one of the punishments for taking drugs, fighting or having gay sex."

-- Newsday (New York), July 3, 2003

"At the age of 21, he had spent 10 days in a torture cell. He says it's a hard thing to talk about, even now. When he does, he describes sadistic brutality with matter-of-fact detail. His tormentors did everything to stop him from sleeping so that he didn't know whether it was night or day. 'Then they take you,' he says. 'They put you flat on a table. Then they tie your legs and hands and they put you under a water tap. Then they let the water tap drip. You cannot move your head and they say you have to confess.' This went on for hour after hour before he passed out. 'One drop,' he says. 'But it's like a bomb.' 'The other one was that they bring in an animal,' he says, searching for the English word. 'Yes, a goat. They put a lot of salt on your feet and they bring in the goat to lick your feet.' The process, he says, induces uncontrollable laughing and crying at first and builds into a loss of control of the nervous system -- eventually a loss of consciousness."

-- CanWest Interactive, June 29, 2003

"You don't know, maybe it is your brother who is going to submit a report against you; maybe your cousin. You can't trust anybody. Even if you are alone in the toilet, you can't say anything. Maybe your wife will hear it."

-- Jasim, a former Ministry of Information official, National Catholic Reporter, June 20, 2003

"Stand at the mass grave near Kirkuk, where huge mechanised trucks churn the earth in clouds of dust. Look at the skeletons now tenderly reburied in simple wooden coffins. Talk to Nasir al-Hussein, who was only 12 at the time of the 1991 mass arrests. He, his mother, uncle and cousins were piled on buses. They turned off on to a farm road and the executions started. People were thrown into a pit, machine gunned and then buried with a bulldozer. Nasir crawled out of the mass grave, leaving his dead relatives behind."

-- The Times (London), June 18, 2003

"We should have been treated as heroes by Uday. Instead, we were sent to prison and had our heads shaved when we returned to Baghdad."

-- Maki Hemal, a member of the Iraqi wrestling team, Sunday Telegraph (London), June 15, 2003

"Saddam Hussein's regime was similar to those of the Nazis and the Khmer Rouge in Cambodia in that there is a vast amount of documentary evidence relating to the atrocities they committed.

"We visited the notorious Abu Gehb Prison outside Baghdad and found written records of prisoners being executed by being put through mincing machines."
 -- **Western Mail, June 14, 2003**

"My family lived in fear of his men, who were always watching us. Family friends were assassinated, tortured, or just disappeared."
 -- **Sharif Ali, The Daily Telegraph, June 11, 2003**

"It was turned into a prison and torture chamber. Many of the people who carried out the coup were later tortured there. It was dubbed the 'Palace of the End.'"
 -- **Sharif Ali, pointing out what happened to his family palace, The Daily Telegraph, June 11, 2003**

"These people were taken from prisons and detention centers to execution," said Sheikh Kadhim Fartousi, a prominent Baghdad cleric who took charge of the excavation. "We believe there are thousands of other victims here."

"Fartousi said security sources in the former government told his organization that some resisted the executions. 'A colonel in charge of intelligence objected to the killing and said, "The regime is on the verge of collapse, why execute people?" So he was executed,' Fartousi said, as the smell of decaying bodies wafted through the blazing heat."
 -- **The Washington Post, June 9, 2003**

"Two witnesses from the village of Salman Pak, south of the capital, said they had seen 115 corpses stacked in piles here on April 10, all of them men with their hands tied behind their backs who had been shot in the back of the head. In attempts to exhume bodies on Saturday and today, Iraqis retrieved the remains of eight victims, none of whom, however, appeared to have died recently."
 -- **The Washington Post, June 9, 2003**

"Saddam killed our people for resisting him. Some were executed for speaking in a religious way when greeting his men. A woman was killed for wearing a veil."
 -- **Bakr al-Saad, a member of the Daawa party, Orlando Sentinel, June 8, 2003**

"We were forbidden even to have a funeral. Sheik Jaafar's men told us our house would be destroyed if even one relative came to console us," said Qadir, whose spare living room is adorned with a photo of President Bush and British Prime Minister Tony Blair. "The security men came anyway and smashed our furniture and dishes."
 -- **Los Angeles Times, June 8, 2003**

"Now, 12 years later, Mr. Shaati cannot remember if the women and children beside him screamed as the bullets hit, or whether the men in the hole moaned as they died. He only recalls a moment of hollow silence when the soldiers stopped shooting. Then came the throaty rumble of a backhoe and the thud of wet earth dropping on bodies. He survived but saw hundreds of other innocents buried in another of Saddam Hussein's anonymous mass graves."
 -- **The New York Times, June 2, 2003**

"Her most disturbing memory is of the time she felt nothing but her own pain. After the beatings and electric shocks, Suriya Abdel Khader would find herself once again in the fetid cell, a room so crowded that most

prisoners could only stand. The women died upright, then slumped to the floor, but Ms. Abdel Khader remembers registering only a dull flash of annoyance whenever that happened. 'Get this body out of the way,' she would think to herself. 'It's taking up room.' She was imprisoned, she believes, because her four brothers had been arrested in Mr. Hussein's blanket crackdown on Shites suspected of supporting Iran or the Islamic Dawa Party."

-- **The New York Times, June 2, 2003**

"The soldiers took them out in groups of 100 to 150 people. When his time came, Mr. Shaati was ordered to remove his T-shirt and rip it into strips that were tied over his eyes and around his hands. The prisoners were herded onto a bus, everyone holding on with their teeth to the shirt of the person in front of them. When they arrived at a field - Mr. Shaati is still not sure where - their grave had already been prepared. 'They led us down an incline into a wide long hole,' he said. 'It was quiet. No one fell or even cried. I was positioned very close to the corner, maybe second or third from the wall. Then they started shooting. Somehow I wasn't hit. By then, I guess, they didn't go to the trouble of shooting all of us.' After the grave was covered, Mr. Shaati, alive but choking on dirt, wormed his way out of the ditch. He punched through the earthen blanket with his head, and worked himself free of the cloth straps. Gulping the cold night air, he knew that all his soldierly ideas about honor and country counted for nothing."

-- **The New York Times, June 2, 2003**

"She spent one year being moved from prison to torture center to prison and back. Her tormenters would hang her from a hook in the ceiling by her arms, which were bound behind her back. Sometimes they added electric shocks. Sometimes they beat her on the soles of her feet until they were engorged with blood and her toenails fell off. She was 25.

"I was lucky that I became like a dead body,' she said. 'I didn't know what was going on around me. There was no water, no bathroom. The only food was two big pots they brought in, one with dirty rice and one of soup. You had to fight for it. If you were strong and healthy, you'd get food. If you were weak, you'd wait.'

"After the torture came the sham trial, then a sentence to spend her life at Rashad women's prison, a maze of unheated cells where the sewage would float from the one toilet down the corridors and seep onto the women's rough mattresses."

-- **The New York Times, June 2, 2003**

"Clawing through the dirt, Abdelhassan al-Mohani collected his brother bone by bone. He knelt in a hole at the edge of a cemetery near the village of Muhammad Sakran, just outside Baghdad. The faded writing on a plastic armband in the grave told him this was his brother, Abdelhussein. Mr. Mohani held the skull and gently brushed the dirt from the eye socket. Then he wept.

"Abdelhussein had disappeared on his way to work in Baghdad on Jan. 23, 1981. His family never heard a word from the government, but eventually they drew the obvious conclusion: as a Shiite, he must have been arrested in the Islamic Dawa Party roundup."

-- **The New York Times, June 2, 2003**

"At the first grave site that the team is investigating - a bleak square-mile expanse of sand and silt near the town of Musayib, 40 miles south of Baghdad - local people have already dug up the skeletal remains of almost 650 victims. Blindfolded with their hands tied, they had been herded into trenches and shot - executed in March and April 1991 during the failed uprising that followed the first Gulf war. Some were buried alive when the holes were filled in over them by bulldozer. In a race against time, it is now up to the scientists from Inforce (the International Forensic Centre), a British charity set up 18 months ago to investigate mass killings and genocide, to persuade their relatives not to uncover any more bodies so that vital forensic evidence is kept intact."

-- **The Sunday Telegraph (London), June 1, 2003**

"His mother tried to keep him close, but her hands were tied and she could not hold the children. They all stumbled into the ready-made grave. 'They were shooting at us, but I didn't get hit,' Mr. Hussein said. 'I was lying on top of my mother. Then someone came down in the hole and dragged me up by my collar and yelled, 'Shoot

this kid!" I was pretending to be dead. And they started shooting at me again, but still I didn't get hit. Then the shovel came.' He felt himself being lifted with the dirt and dropped once again into the hole. 'I rolled myself to the edge and then to a place where there were reeds and water and the reeds were all sticking in my face,' he recalled. 'My body wasn't covered with the dirt, just my head. I could breathe but I didn't move. A man came to check and was standing over the hole where everyone was buried and he called to the shovel driver, "Come and cover this kid." But the driver, maybe he didn't hear, because he didn't come.'"

-- **The New York Times, June 1, 2003**

"A chef at Baghdad's exclusive Hunting Club recalls a wedding party that Uday crashed in the late 1990s. After Uday left the hall, the bride, a beautiful woman from a prominent family, went missing. 'The bodyguards closed all the doors, didn't let anybody out,' the chef remembers. 'Women were yelling and crying, "What happened to her?"' The groom knew. 'He took a pistol and shot himself,' says the chef, placing his forefinger under his chin.

"Last October another bride, 18, was dragged, resisting, into a guardhouse on one of Uday's properties, according to a maid who worked there. The maid says she saw a guard rip off the woman's white wedding dress and lock her, crying, in a bathroom. After Uday arrived, the maid heard screaming. Later she was called to clean up. The body of the woman was carried out in a military blanket, she said. There were acid burns on her left shoulder and the left side of her face. The maid found bloodstains on Uday's mattress and clumps of black hair and peeled flesh in the bedroom. A guard told her, "Don't say anything about what you see, or you and your family will be finished."

-- **Time, May 25, 2003**

"Uday's physical ailments seemed to heighten his sadistic tendencies. According to his chief bodyguard, when Uday learned that one of his close comrades, who knew of his many misdeeds, was planning to leave Iraq, he invited him to his 37th-birthday party and had him arrested. An eyewitness at the prison where the man was held says members of the Fedayeen grabbed his tongue with pliers and sliced it off with a scalpel so he could not talk. A maid who cleaned one of Uday's houses says she once saw him lop off the ear of one of his guards and then use a welder's torch on his face."

-- **Time, May 25, 2003**

"Uday's favourite punishment was the medieval falaqa, a rod with clamps that go around the ankles so that the offender, feet in the air, can be hit on the bare soles with a stick. A top official in radio and TV says he received so many beatings for trivial mistakes like being late for meetings or making grammatical errors on his broadcasts that Uday ordered him to carry a falaqa in his car. Uday also had an iron maiden that he used to torture Iraqi athletes whose performance disappointed him.

-- **Time, May 25, 2003**

"A map provided by a former driver for Iraqi military intelligence brought Abdulaziz al-Qubaisi Abu Musab to the abandoned Iraqi military camp here this morning in search of the answer to the question that most Kuwaitis have asked - and dreaded - since the end of the 1991 Persian Gulf war: where are the nearly 600 missing Kuwaitis? "Mr. Abu Musab, a member of the Iraqi National Congress, the political movement headed by Ahmad Chalabi, said he had been given the map by a man who, in October 1991, was among the drivers who took the Kuwaiti prisoners to their execution in Baghdad and subsequent burial here, 50 miles west of the capital. "It was impossible to speak directly to this driver, who calls himself Samir and still fears for his life, or to say today how accurate his account of the execution is. But the map he gave Mr. Abu Musab proved very accurate."

-- **The New York Times, May 17, 2003**

"Abas Rahim, a speedy 24-year-old left wing for Police, is one of Iraq's finest players. After returning home from 1997 Junior World Cup qualifying matches in South Korea, Rahim was jailed for 21 days. He was the team captain, as well as the tournament's most valuable player, and he was punished for the team's failure. "Five years later, after trying to quit the team, Rahim missed a crucial penalty kick against the Union Club in Qatar. He was held captive in Hussein's Republican Palace for seven days, he recalled, blindfolded the entire time. Today, he played unafraid."

-- **The Washington Post, May 17, 2003**

"The killing began one morning in October 1991 at 8:30. The frightened Kuwaitis - blindfolded, with hands bound by lime-green plastic ties - were ordered into horseshoe formations at the training school for the intelligence service in Baghdad. The prisoners had been brought there that morning in vans and buses.

"A single intelligence man carrying a machine gun positioned himself inside the horseshoe. The prisoners wept and cried out the Muslim prayer before death: there is no god but God.

"The gunfire began. The shooter pivoted, according to the account provided to Mr. Abu Musab, using the horseshoe formation to make the executions quicker. Formation after formation was brought forward until all were dead. All were men, save one."

-- **Agence France-Presse, May 17, 2003**

"An intensive search for Kuwaiti soldiers and civilians missing since the first Persian Gulf war may have ended at this remote site, where skulls, brown pants and bones sticking up eerily from the sand were unearthed in the first day of digging at the site.

"When Saddam Hussein fell, there were grim hopes that the missing might still be alive but starving in one of the regime's prisons. Coalition searches found the prisons empty. Instead, it now appears the Kuwaitis were already dead.

"Ten buses carrying the 'disappeared' had been driven northwest of Baghdad past the relatively prosperous city of Fallujah, according to the driver of one of the buses. The prisoners were unloaded, shot, then buried in deep pits."

-- **The Washington Times, May 17, 2003**

"Desperate relatives and friends were digging to find remains of their loved ones yesterday at what US soldiers said was the largest mass grave of Saddam Hussein's victims discovered in Iraq. ... Seven days into the dig, the scene resembles a battlefield of the dead: the loose sandy soil carved into trenches, ditches and foxholes by a bulldozer. All around lie piles of remains: pelvic bones, ribs, femurs and skulls -- one still wearing its weave-pattern prayer cap, another the blindfold affixed by his killers shortly before death. From many protrude the identity cards, amber necklaces, front-door keys and watches used by relatives to identify their brothers, cousins and sons. A plastic artificial leg sticks out of one pile, two crutches from another."

-- **The Australian, May 15, 2003**

"On an exhumed mound beside the most westerly row of corpses, Ali Abdul Hassan Mekki, 50, sat with a plastic bag between his feet. Thirteen years ago his brother, Jaffar, disappeared during Hussein's post-rebellion slaughter. It was, for him, the worst possible outcome -- misery without certainty. 'I think this is my brother,' he said. 'This is my pullover, which he always borrowed from me to wear, but it is not enough to identify him. The problem is that I don't recognise this wallet and the identity card does not have any writing on it.'"

-- **The Australian, May 15, 2003**

"The executions took place two or three times on most days, Arjawi said. Each time, between 100 and 150 blindfolded people, their hands and sometimes feet bound, were led into pits about 10 feet deep. Gunmen then fired into the pit, often for several minutes, Arjawi said. A bulldozer then pushed dirt onto the bodies, sometimes burying or crushing people who had survived the volley and were trying to climb out."

-- **Los Angeles Times, May 14, 2003**

"[J]ust to see the landscape of bones mixed with clothing, skulls strewn in the splay of human detritus and other remains is chilling. At first, it just seems like hundreds of bundles of clothes have been laid out on the dikes and roads that cut through the marshes here.

"Then the traces of human anatomy appear. A femur from a leg, a humerus from an arm, a shard of pelvis, and

skull peeking out from a gray blanket that someone assembling remains laid down. The bundles reveal themselves as the former repositories of living human flesh, before the gunfire sent them on their journey into the marsh.

"It's a kind of hell out there,' said Mr. Nasir, who no longer plants onions where so many bodies have been desecrated. 'We have always known that there were people here, but we couldn't take them,' he said. 'We knew our Muslim brothers were not buried properly, but we couldn't say a word.'"

-- **The New York Times, May 14, 2003**

"Hundreds of Iraqis whose loved ones vanished during the 1991 Shiite Muslim uprising watched Tuesday as workers dug into a mass grave, a backhoe pulling up eight or nine bodies at a time, and perhaps as many as 3,000 over the past four days. Villagers clutched the remains to their chests, trying to keep them intact as they fell from the machine's big shovel. They laid the bodies in the dirt nearby, next to hundreds of others waiting to be claimed. Then they searched for personal papers, the remnants of a wristwatch or other items that might reveal the identities of the dead."

-- **Los Angeles Times, May 14, 2003**

"Seven days into the dig, the scene resembles a battlefield of the dead, the loose sandy soil carved into trenches, ditches and foxholes by a bulldozer. All around lie piles of remains: pelvic bones, ribs, femurs and skulls--one still wearing its weave-pattern prayer cap, another the blindfold affixed by his killers shortly before death. From many protrude the identity cards, amber necklaces, front-door keys and watches used by relatives to identify their brothers, cousins and sons. A plastic artificial leg sticks out of one pile, two crutches from another."

-- **The Daily Telegraph (London), May 14, 2003**

"As clumps of hair blew across the hard, dry land, Jabar Sattar sat rocking and sobbing on a hill of dirt created by the backhoe. He cradled a clear plastic bag containing the remains of his younger brother Faris. Faris was a soldier, he said, and had just returned from Kuwait when private security men arrested him in his front yard, just two miles from the grave site. 'I looked for 12 years,' Sattar cried into the bag of remains. 'Every day I told myself, you're alive and will come back. Now what am I going to say to our father?'"

-- **Los Angeles Times, May 14, 2003**

"In two days, they've found 2,000 bodies--men, women, children, some handicapped. Many skeletons were still blindfolded. The Iraqis and the US military believe there are several thousand more. This is an archaeological site. And it's no accident the bodies were buried here. Under Saddam Hussein, it was illegal for Iraqis to dig here, or even walk on the site. Search teams look for identification inside crumbling wallets, adding each name to a ledger. If there's no ID, they hope a relative might recognize something -- a watch, a scarf."

-- **ABC World News Tonight, May 13, 2003**

"The skeletal remains on display Monday showed signs of physical trauma. Some still had faded bandages tied around the eye sockets and black cloth binding the feet. Several skulls had large holes on one side or were crushed in the back. In each open wooden coffin, the bones were carefully wrapped in white cloth, surrounded by scraps of hair, bits of teeth and bones. The visible evidence of their demise drove scores of black-clad women to wailing and men to weep."

-- **Associated Press, May 12, 2003**

"For people streaming past 32 coffins laid out in Basra's al-Jumhuriya Grand Mosque on Monday, grief competed with anger as they searched for relatives who disappeared after a Shiite Muslim uprising in 1999. Peering into a simple plywood coffin, Karima Musa Mohammed carefully looked over the remains inside--a ragged blindfold tied around the skull, feet bound by black cloth, faded gray pants, light gray shirt. 'No, not him. Not my son,' she pronounced, then burst into tears. The mass grave was one of many being unearthed around the country as Iraqis come to grips with the reality of Saddam Hussein's brutal regime."

-- **Associated Press, May 12, 2003**

"The grave was no more than a long trench, with dirt shoveled over the men executed for their role in the uprising here in 1999 after the killing of a prominent Shiite cleric, Muhammad Sadiq al-Sadr, said relatives who viewed the remains today.

"On March 25, 1999, a shepherd in the desert about 45 miles north of Basra saw men being brought by Baath Party trucks to an open clearing, said Ali Hassan, 20. The shepherd said he saw a backhoe dig a long trench and the men, blindfolded, were lined up in front of the ditch. Then they were shot."
 -- **The New York Times, May 12, 2003**

"Two years ago, Iraqi wrestler Mitham Ali Hadi was competing in the Arab championships in Syria and defected. When the delegation returned home without him, its members were imprisoned and tortured. The punishment - which included wrestlers, coaches, journalists and referees - was a message to others who might have been considering defections. Even the chairman and the secretary of the wrestling federation were imprisoned, though they weren't in Syria during the tournament. 'At night, we used to hear the voices of our colleagues being tortured. We felt their pain alongside them,' former wrestling federation head Loai Sateh said in a recent interview."
 -- **Associated Press May 11, 2003**

"Fakher Ali al-Jamali, who headed Iraq's handicapped team, was whipped with electric cables for two days after two members of his team went missing during a 1998 tournament. He was released only after they showed up."
 -- **Associated Press May 11, 2003**

"One of the tools used by Odai to torture athletes is currently on display at al-Hikma Mosque in Baghdad. It is a 2-meter (6-foot) body suit of metal bars that was used to restrain offending athletes under the scorching sun for hours. One athlete who spoke on condition of anonymity said he was placed in the suit for long hours under blistering sun. A hose dripped water into his mouth to prevent him from dying of dehydration. 'Whenever I tried to move my body, I would feel the burn of the metal rods,' said the man, displaying scarred legs and hands."
 -- **Associated Press, May 11, 2003**

"At Baghdad's teeming Al-Mutanabi book market, Ali al-Saadi held up a gilded Islamist book and recalled the one he said led to his torture in one of Saddam Hussein's military prisons. 'When I was a literature student in 1982, intelligence officers found a book by Mohammed Sadeq Sadr in my house,' said Saadi of the Shiite ayatollah whose 1999 murder was widely attributed to Saddam's Sunni-majority regime. They accused me of organizing a political group. I spent three years in jail and suffered a lot,' he said, showing scars on his wrists from prison chains and gaps where he said three teeth had been pulled out with pliers. Saadi was just one of many writers and thinkers at the weekly market who celebrated being able to buy and sell books that were illegal under the old regime."
 -- **Agence France-Presse, May 9, 2003**

"First they broke his right arm with a pipe. Then they punctured his right eardrum with a skewer. And then they tried to break his right leg with a bat. But when the X-rays that Uday Hussein demanded as proof of their efficiency showed in fact they had not broken Tariq Abdul Whab's leg, his captors took him back to prison where someone smashed his right leg with such ferocity that his toe hit his kneecap. Mr. Whab received all this treatment simply because Uday thought the sports television reporter was being disloyal to him by talking to soccer players he didn't like."
 -- **The Vancouver Sun, May 3, 2003**

"In May 1991, having served in the Persian Gulf War with the Marines, I volunteered for further duty in Provide Comfort -- a joint military operation designed to assist in the relocation of Kurdish refugees into northern Iraq. Assigned to the 24th Marine Expeditionary Unit, I was flown to the city of Zakho, where the unit was establishing its headquarters in and around an abandoned Iraqi divisional headquarters building....

"As the Marines began digging defensive positions and putting up tents, a grisly discovery was made. Heavy equipment had unearthed myriad body parts; hands, arms, legs, etc., were uncovered in what was determined to have been a mass grave. Most telling among this evidence of inhumanity was an infant's sandal.

"The body parts were reburied immediately after their discovery, but for many days the stench of rotting flesh lingered in the air until all the remains were located and reburied. It was later learned from the Kurds that about 70 of their tribesmen had been taken into this Iraqi divisional HQ and that none had come out alive. The victims were brutally tortured and executed, their remains then thrown into a common grave."

-- James Zumwalt, op-ed in *The Washington Post*, April 30, 2003

"...Turkish officials were told how Turkomans and Kurds were tortured together by Saddam Hussein's Iraqi police at the notorious security headquarters of Kirkuk. 'I was taken into custody and forced to sit on my knees for six days in a cell one meter by one meter along with a Kurdish prisoner,' a Turkoman man told the group. The man, who asked not to be named, said, 'Even this shows how we and the Kurds suffered the same fate in this city.'"

-- *Turkish Daily News*, April 29, 2003

"As part of the prison routine, Issa was tortured daily, sometimes twice a day. Battery acid was spilled on his feet, which are now deformed. With his hands bound behind his back, he was hanged by his wrists from the ceiling until his shoulders dislocated; he still cannot lift his hands above his head. The interrogators' goal: 'They just wanted me to say I was plotting against the Baath Party, so they could take me and execute me. If they got a confession, they would get 100,000 dinars [roughly \$40].'"

-- *Newsweek*, April 28, 2003

"A nondescript five-story building notable only by the extra barbed wire on the roof, the Haakimiya Prison is actually 10 stories. Below ground are interrogation cells where unspeakable horrors were committed. ...A former inmate, Mohsen Mutar Ulga, 34, ...was searching for documents about his cousin, executed under Saddam. Ulga said he was sentenced to 12 years in jail for belonging to an armed religious group called 'the revenge movement for Sadr,' referring to a martyred Shiite cleric. He had been arrested with 19 others; the lucky ones were executed right away. The rest were tortured with electric cattle prods and forced to watch the prison guards gang-rape their wives and sisters. Some were fed into a machine that looked like a giant meat cutter. 'People's bodies were cut into tiny pieces and thrown into the Tigris River,' said Ulga.

"Ulga and the reporter silently walked through the darkened cells at Haakimiya, which was surprisingly clean, except for the graffiti on the walls. GOD I ASK YOUR MERCY, scratched one prisoner who'd marked 42 days on the walls. SAVE ME, MARY, implored another, presumably a Christian. IN MEMORY OF LUJAY AND ABBAS WHO WERE TORTURED, read another."

-- *Newsweek*, April 28, 2003

"Kubba's money insulated his family from mayhem, but it did not shield him from witnessing the almost casual slaughter of his people. Last week he recalled a 'scene that haunts me still.' Kubba was driving his Mercedes through Basra's Saad Square when he came upon some 600 men who had been detained while police checked their IDs. According to Kubba, 'Chemical Ali' Hassan al-Majid, Saddam's half brother and the tyrant of southern Iraq, stopped and inquired, 'No IDs? Just shoot them all.' Kubba watched as 'they shot over 600 people in front of me.'"

-- *Newsweek*, April 28, 2003

"Almost as large as Saddam's palaces are his many prisons, where countless Iraqis were tortured and killed. We take you now inside one of Saddam's most notorious prisons, 18 miles west of Baghdad, and it's hard to imagine a grimmer place. US soldiers are searching what remains of one of the biggest and most elaborate prisons in the world. Saddam Hussein never cut corners when it came to punishment. Abu Ghraib once held tens of thousands of human souls – criminals, political enemies, and those who just happened to get in the way. A 12-year-old Iranian boy visiting his grandmother near Basra in 1985 was swept up in an Iraqi invasion. He was still here 15 years later.

"[H]e lived with 28 other detainees in a nine-meter-square cell, dividing up 1.5 kilos of rice and porridge a day. 'It was so cramped we couldn't sleep on our backs, we had to sleep on our sides, like spoons. And they brought us polluted water to drink, so we all had diarrhea.' Ulga was released last fall during Saddam's surprise general amnesty. 'Most people don't know that before the amnesty, they executed 450 prisoners so they would never go free,' said Ulga."

-- **Newsweek, April 28, 2003**

"The writers who praised Saddam would get treated well. The members of the Baath party were always watching the others. There were always security members at my plays and sometimes they (the plays) were not allowed," said [Aziz Abdul] Sahib. Sahib said he had been selling his writings at a public market once a week 'just so I could eat.'"

-- **Agence France-Presse, April 28, 2003**

"The massive prison cast a shadow over the entire neighborhood. Yehiye Ahmed, 17, grew up nearby. The prison guards were his neighbors; the inmates' screams were the soundtrack of his young life. 'I could hear the prisoners crying all the time, especially when someone was killed. I could hear everything from my house or when we played soccer behind the prison,' says Yehiye, a quiet boy, with large, haunted brown eyes and a body that suggests malnourishment.

"Yehiye and his friends would often go inside the Abu Ghraib compound to sell sandwiches and cigarettes to visitors, guards, and sometimes even prisoners. 'I saw three guards beat a man to death with sticks and cables. When they got tired, the guards would switch with other guards,' he recalls. 'I could only watch for a minute without getting caught, but I heard the screams, and it went on for an hour.'"

-- **Newsweek, April 28, 2003**

"Radi Ismael Mekhedi spent 10 years behind bars. Last week, he wandered through the looted prison and stood behind the red bars of his former cell for the first time in over 10 years. 'I was severely tortured during my imprisonment because I was considered a traitor to my country. I never believed a person could be subjected to such treatment by another human being,' Mekhedi says. 'Life was already painful under Saddam, and if you came to the prison, you were always in fear for your life.'"

-- **Newsweek, April 28, 2003**

"Poet Imad Kadhum...said he had been terrified that Baath members would inform on him and that several friends were arrested for offending Saddam, who was himself credited with penning several self-aggrandizing novels.

"All the writers here refused Saddam Hussein and many were in trouble if we did not praise Saddam in our poetry or stories,' he said. 'We never accepted that we were criminals. If our work was disliked by Saddam or (eldest son) Uday, then we would be placed in jail.'

"A lot of (writers) may have been killed, and to this day we don't know what has happened to them,' Kadhum said."

-- **Agence France-Presse, April 28, 2003**

"... Anwar Abdul Razak, remembers when a surgeon kissed him on each cheek, said he was sorry and cut his ears off. Razak, then 21 years old, had been swept up during one of Saddam Hussein's periodic crackdowns on deserters from the Army. Razak says he was innocently on leave at the time, but no matter; he had been seized by some Baath Party members who earned bounties for catching Army deserters. At Basra Hospital, Razak's ears were sliced off without painkillers. He said he was thrown into jail with 750 men, all with bloody stumps where their ears had been. 'They called us Abu [Arabic for father] Earless,' recalls Razak, whose fiancée left him because of his disfigurement.

"No one is sure how many men were mutilated during that particular spasm of terror, but from May 17 to 19, 1994, all the available surgeons worked shifts at all of Basra's major hospitals, lopping off ears. (One doctor who

refused was shot.) Today, Dr. Jinan al-Sabagh, an administrator at Basra Teaching Hospital, insists that the victims numbered only '70 or 80,' but he'd prefer not to talk about it. He says the ear-chopping stopped before his own surgery rotation came up. 'I want to forget about all this. I vowed I would never do it. I said I am a surgeon, not a butcher....'"

-- **Newsweek, April 28, 2003**

"The Iraqi Intelligence Service established a unit to assassinate Saddam Hussein's enemies at home and abroad that claimed 66 successful 'operations' between 1998 and 2000, according to documents obtained by The Times.

"Found on the floor of a looted Intelligence Service villa on the east bank of the Tigris River here, the six-page file described the program and contained suggestions for improving its effectiveness - including obtaining poisonous gas disguised as perfume or explosives that would detonate when the car of the target passed by."

-- **Los Angeles Times, April 25, 2003**

"A slightly broader picture of what happened has emerged from the chief gravedigger, just 21 years old. He is Muhammad Muslim Muhammad and he said he began digging graves here when he was 14 to fulfill his military service.

"He said he received the bodies every Wednesday at about 11 a.m., after the weekly hangings at around 5 a.m. There were never fewer than nine bodies to bury. During one especially bad time in 2001, he said, the numbers rose. One day he buried 18 people. He said he had never told anyone the details of his job. 'I didn't open my mouth, or I would have ended up with these poor people here,' he said."

-- **Report on Al Qarah Cemetery, The New York Times, April 25, 2003**

"Saboowalla said he was imprisoned because he spoke his mind to fellow travelers fleeing Baghdad after Saddam's 1990 invasion of Kuwait. He said he'd remarked that if talks with the United Nations did not work, force would be used against Saddam. '...someone overheard me. The police came the same day and asked why I spoke against Saddam,' said Saboowalla. 'I told them it was just normal conversation and I didn't mean it.'"

"An Iraqi court sentenced him to 20 years for 'insulting' Saddam, who was then Iraq's president. He said the police testified that he had advocated 'shooting and killing Saddam.' The years in jail have made him watch his words. He refused to talk about how he was treated in jail. But his younger brother... said Saboowalla had spoken of being placed in solitary confinement for weeks and 'not seeing the sun' for 27 months."

- **Report on the return to India of Anis Mohammed Saboowalla, who had been imprisoned in Iraq since 1991, Associated Press, April 25, 2003**

"Mr. Hani came to a cemetery here today, like dozens of other Iraqis, not with the name of his dead brother but with a number. Satter's number was 535. A cousin, Sagur, arrested at the same time, was 537. These numbers were what was left of people convicted as enemies of Saddam Hussein and then made to disappear. Their graves were not dignified with names but with numbers painted on metal plates. The plates spread like rusty weeds, covering more and more feet of desert every year Mr. Hussein held power.

"But now that he is gone, the families of the disappeared are finding the numbers, matching them to the metal plates and finally collecting their dead. These were people executed - most by hanging in the fearsome Abu Ghraib prison a mile away - merely because the government considered them a threat. Many were Shiite Muslims more active in their religion than the Sunni-dominated government felt it could tolerate."

-- **Report on Al Qarah Cemetery in The New York Times, April 25, 2003**

"Thousands of people are missing in Iraq, victims of Saddam Hussein's dictatorship, but a more visible legacy are the parts that are missing from people who survived. Missing eyes, ears, toenails and tongues mark those who fell into the hands of Mr. Hussein's powerful security services."

-- **The New York Times, April 24, 2003**

"The players would start crying," said Emmanuel Baba, 69, a former player who became a coach renowned throughout the Arab world, where he is known by his nickname, Ammo Baba. "They would tremble with fear."

"When they got out of prison, they would come to me and lift their shirts to show me the red stripes on their back. They had been beaten with a metal cable. Then the guards threw salt water at them, so the scars would stay for life."

-- **The Washington Post, April 24, 2003**

"My brother disappeared in 1992," this woman told us. "We never heard another thing from him." He and hundreds of others buried here were Shi'ite Muslims, Saddam's religious enemy. Witnesses say they were dumped in the middle of the night, without the dignity of a coffin, often mixed with the bones of another. Until this week, their whereabouts were unknown. But now, armed with shovels and mysterious scraps of paper, families are finally coming to reclaim their own. These people may have been just nameless, faceless victims to the regime, but if so, the question arises why would the regime have taken so much time to bury each one individually, and then mark each grave with a number? The answer: The regime didn't keep track. The cemetery's caretaker did. There must be thousands of people in this book. Thousands of names. Under penalty of death, this man stole Saddam Hussein's execution list and kept note of the bodies that came his way. "I suffered so many years," he said. "My hair turned white from the pain and guilt." But now he is free to tell, and when we went to visit him there was a line out the door, all people looking to match a name with his secret numbers. It is an act of courage that may finally bring some peace to families with homecomings so long overdue."

-- **CBS Evening News, April 24, 2003**

"Farris Salman is one of the last victims of Mr. Hussein's rule. His speech is slurred because he is missing part of his tongue. Black-hooded paramilitary troops, the Fedayeen Saddam, run by Mr. Hussein's eldest son, Uday, pulled it out of his mouth with pliers last month, he said, and sliced it off with a box cutter. They made his family and dozens of his neighbors watch.

"...Salman was blindfolded and bundled into a van. Residents of his neighborhood say the van arrived in the afternoon with an escort of seven trucks carrying more than a hundred black-uniformed fedayeen wearing black masks that only showed their eyes. They rounded up neighbors for what was billed as a rally; Mr. Salman's mother was ordered to bring a picture of Mr. Hussein. Two men held Mr. Salman's arms and head steady, and pointed a gun to his temple. Another man with a video camera recorded the scene. "I was standing and they told me to stick my tongue out or they would shoot me, and so I did. It was too quick to be painful but there was a lot of blood." The fedayeen stuffed his mouth with cotton and took him to a local hospital, where he got five stitches, no painkiller and was returned to prison."

-- **The New York Times, April 24, 2003**

"Doctors gave him an injection and he lost consciousness, he said. When he awoke, the right side of his head was wrapped in bandages. It was Sept. 15, 1994. "I started crying," Mr. Ghanem said. "I felt crippled. I felt oppressed. I hated Saddam with all of my heart, but I didn't know what to do."

"He was sent to prison where he said he saw hundreds of others missing one ear. Many, like Mr. Ghanem, had inflamed wounds.

"His mother came every Friday, selling off household appliances to buy painkillers and antibiotics for her son. Others were less fortunate. Mr. Ghanem described a medieval scene in which delirious and dying inmates lay on the prison's dirt floor screaming from pain. "The right side of some of the men's heads were puffed up like red balloons," he said. Two of his friends died from infections.

"Saddam, God curse him, treated my son like an animal," said Mr. Ghanem's weeping mother. "Only animals have their ears cut off."

-- **The New York Times, April 24, 2003**

"Kadhim Sabbit al-Datajji, 61, a resident of the poor Shiite neighborhood known as Saddam City under Mr. Hussein, said his trouble began when the eldest of his seven sons became old enough to join the Baath Party, but did not. "Some Baathists in the neighborhood began asking why no one in my family was a party member and saying that with so many children, my family could cause trouble," he said. "They asked, "Why don't you or your

sons join? We think you are in an opposition party."

"He now has a walleyed stare to show for eight years in prison. He is quick to pop out his glass eye for a visitor - and to tell of how he lost the real one to torture."
-- **The New York Times, April 24, 2003**

"I thought many times of leaving soccer," said Laith Hussein, captain of the national team and a star in Iraq. "But how could I? I was afraid of what Uday would do to me and my family. I would sit and cry when I was by myself. I want to play soccer for myself, and for the Iraqi people, not for Uday."
-- **The Washington Post, April 24, 2003**

"Though the tales of punishment were not a closely guarded secret in Iraq, it is only now that many athletes are talking freely about their experiences. A common thread runs through all their narratives. After losing a competition, players and their retinue were taken to the Olympic Committee building, where they were harangued before being transferred to a prison, usually Radwaniya. They often had their heads shaved as a mark of shame and spent the first days in prison without food. Many said they were whipped on their backs, legs and arms by thick metal cables that hung from a wall in the prison and were named after snakes. And if they were offered jobs playing abroad, Uday Hussein demanded a cut of the contract if they wanted exit visas to leave Iraq."
-- **The Washington Post, April 24, 2003**

"There was a room painted in red in the Olympic Committee building where athletes were held in isolation for days on end," said Sabat, who has a passing resemblance to the French football star Zinedine Zidane. "We were all terrified of this room." Iraq's state-sponsored sporting violence even extended to journalists who covered competitions and matches. One reporter, who said he preferred not to give his name because he was still afraid of 'Uday's men,' told AFP that such violence was widespread in the dark years of Saddam's 24-year rule. "I was tortured because I'd criticised the government's sport policies," he said. "They took me to one of their special prisons. They blindfolded me and then tortured me with electricity."
-- **Agence France-Presse, April 23, 2003**

"Near Kirkuk, U.S. military forces discovered about 1,500 unmarked graves last week near a military base and industrial park. Officials believe they are the remains of victims of Saddam's repression of ethnic minorities, including Iraqi Kurds. Tens of thousands of Kurdish men disappeared under Saddam and were killed, according to human rights groups."

"Beth Ann Toupin, an Iraq specialist with Amnesty International, said it is still early to know the magnitude of rights abuses under Saddam. 'There's probably much more to be found,' she said, noting that hidden prisons may be discovered. 'And what's new to us is that now people care.'"
-- **The Washington Times, April 23, 2003**

"In 2000, Mr Abu Sakkar [a clandestine government agent] was caught "under-reporting" activities in the mosques and sent for two months to Tourist Island on the Tigris river, south of Baghdad, to receive a crude brand of re-education."

"Three of my fellow Shias were shot in front of me," he said. When he returned to his work with the police campaign to put down Shia opponents and rebels, he witnessed more savagery. "One day I walked into the station and the room of the interrogation office was wide open. I saw Captain Abbass, one of our men, beating a man on the floor. I recognised him as a Shia religious student. He beat the man in the head and I noticed and pointed out to the captain that the student was already dead. He just said that he wanted to punish him more and that his hand was the "hand of god"."
-- **The Daily Telegraph (London), April 23, 2003**

"When Shias, both leaders and young religious students, were taken into custody, they were often transferred to

special torture cells.... 'The method of the investigations was usually to hang someone upside down and beat them, hammering hard on their bones,' Mr Abu Sakkar said, pointing to a hook on the ceiling. Some people would be left here for days upside down and would just die of fatigue and thirst."

-- **The Daily Telegraph (London), April 23, 2003**

"The friendly between Iraq and Kazakhstan ended in a 2-1 defeat for the home team. The Iraqi footballers had flunked a crucial penalty, and they dreaded what Uday Saddam Hussein had in store for them after the final whistle.

"Ahmed Sabat, considered one of the most talented Iraqi soccer players of his generation, told the story of that fateful day six years ago.... 'It was a friendly but we'd lost, and we knew what would happen once the spectators left,' said the 27-year-old...."

'The players and the coach were made to lie down on the pitch,' he explained, 'and Uday's men came and beat us with sticks on our feet and on our backs and punched us to punish us.' 'We suffered in silence. The psychological pressure on the players was enormous, especially when it came to penalties.'"

-- **Agence France-Presse, April 23, 2003**

"We found one of our friends and we are trying to find the others. People told us that they were killed here,' said Ali Khaled Shefeq, 40, a chemical engineer, digging at the grave with a spade. He said relatives suspect the men were killed around April 2 . less than a week before Baghdad fell....

'We all feel very sad,' Shefeq said. 'They are brothers. What can we say? God bless them. Until now, we didn't believe Saddam Hussein is gone, that it's over. We pray he will never come back again.'

"Others searching for bodies said they were looking for the remains of eight men who were seized at a mosque a month ago by a paramilitary group loyal to Hussein. A cry went up from the crowd as one of the decomposed bodies was unearthed. 'It's Abdul Rahman, it's Abdul Rahman,' people in the crowd shouted.

-- **Newsday, April 23, 2003**

"This is my brother,' declared Munther Taffuk after examining the freshly exhumed corpse, relieved to a point that he had found his missing sibling after a two-year search. Munther then moved in for a closer look. 'My God,' he screamed. 'They took out his eyes.' He then pulled two matted pieces of cotton wool from the eye sockets of his little brother's skull and wept.

"His sister, Manal, cried openly as she said her younger brother, Muthfer, simply vanished without trace two years ago. 'My God, look what they did. This is my brother, he did nothing wrong.'"

-- **Times of Oman, April 22, 2003**

"General Jawdat al-Obeidi, the proclaimed deputy head of the Baghdad provisional government, said that about 150 political prisoners were found by US troops in a secret prison in Salman Pak, 35 kilometres south of Baghdad, and another 200 were rescued at a spot he refused to name. In Kadhimiya, a primarily Shiite neighbourhood in Baghdad, 25 people were discovered in an underground prison, he said.

"Before Baghdad fell, the guards let water flow into the cells to kill the prisoners before they themselves fled. But the prisoners were smart and built ramps to climb on top of. That's why they didn't drown."

-- **Sydney Morning Herald, April 22, 2003**

"I have spoken to a prison officer who worked there. He had no idea how many people were killed in that prison but he said it must have been thousands. In one corner of that prison outside the walls of an inner secure area we found relatives grieving over an open grave where they had found a number of bodies. Bodies who have had their hands tied behind their backs - they had been shot in the head.

"It is our understanding that these people had been rounded up for the simple crime of having a satellite mobile

telephone. As such they were suspected of being American spies. They were shot in the dying days of the regime even though those who shot them must have known that the end was up."

-- **Tim Rogers, ITV News (UK), reporting from Baghdad on bodies found in a prison run by the Iraqi Ministry of Social Affairs, April 22, 2003**

"I went to kill one person, but suddenly I saw he had guards with him, so I killed four or five of his guards," Ali recalled. "After that, we cut off his head and we put it in a bag and we brought it to Baghdad from Karbala at 4 a.m. We put it in front of Uday's office. He asked us to bring his head."

-- **The Washington Post, April 22, 2003**

"As I began to cut Uday's hair, this man [Uday's press secretary] was praying as they [Uday's bodyguards] extracted his teeth with pliers. But my hands didn't shake. I was always very careful. I knew a small mistake would be the end of me."

-- **Marwan Ali, Uday Hussein's barber, Daily Mail (London), April 22, 2003**

"Ali belonged to Saddam's Fedayeen, a security force led by Hussein's elder son, Uday. For the better part of a decade, he recalled, he assassinated opposition figures, broke the backs of those accused of lying to the government and chopped off tongues, fingers, hands and once even a head.

"It didn't matter if we felt he was guilty or not guilty. We had to do it," he explained. "These people were against Saddam Hussein. If we got orders to punish him, we would go and do it. If Uday said to cut off his tongue, we would do it. Or his hands or fingers or his head. Anything. We would do it."

"I just followed orders," he said.

-- **The Washington Post, April 22, 2003**

"Well, in the beginning, this place looks just like an anonymous office building. And that made it all the more filled with terror, because slowly, prisoners would come up, tell you that they had been held here, that they had been tortured. You look at the walls, and see graffiti written by the prisoners here. And it's heartbreaking, really. Allah, help me. Or, you know, today I'm alive, but tomorrow I'll be underground. You see Iraqi families wandering around trying to find news of relatives, and finding nothing. I was about to leave when a group of agitated Iraqis came up and said, come with me. I have something to show you. It's an execution ground. There are still some bodies there. So I said, ok. Let's go take a look. And indeed, we drove to a very remote part of the prison. It was like a makeshift execution ground. You know, somebody had just hurriedly set some guys up there and shot them. They had been half-buried in the ground."

-- **Newsweek reporter Melinda Liu interviewed on NBC Nightly News, April 22, 2003**

"Jamal al-Attar was 26 years old when the Iraqi Mukhabarat snatched him off the street for questioning. He was accused of being a resistance fighter opposed to Iraq's invasion of Kuwait. Then he was loaded onto a truck with scores of other Kuwaitis. That was the last anyone here [Kuwait] saw of him. Today, Mr. Attar would be 38 years old and would have spent one-third of his life in an Iraqi prison. "I must say that I hope that he is still alive. I hope that all of them are still alive," says Abdul Hamid al-Attar, Jamal's father. "But I have to be frank with myself. I am not that much optimistic."

"Most difficult, say family members, is not knowing whether their loved ones are alive. ... If Hussein did this to his own people, the Kuwaitis received worse, family members say.

"We wish that all of them are alive and all of them will be returned soon to Kuwait. but if not, [their families] should know the truth," says Ali Murad of the National Committee for the Missing and POWs.

"Attar agrees: 'Five or six years ago, we used to insist they are alive and that the Iraqis must bring them back to Kuwait alive. Now we have changed. We say we must know if they are dead or alive. but we can't accept that they are missing.'"

-- **The Christian Science Monitor, April 22, 2003**

"The Baath regime has gone and now we can talk freely with you. They [the corpses] are all political. Ten to 15 bodies would arrive at a time from the Abu Ghraib prison and we would bury them here. The last corpse interred was number 993."

-- **Mohyemeed Aswad, manager of Baghdad cemetery, Agence France-Presse, April 21, 2003**

"The civilians were hanged. Sometimes a soldier would come through and they were all shot. I could distinguish them by their uniforms. This grave belongs to a woman. She was hanged. There are another five cemeteries in Baghdad with secret gravesites so in this city alone there are about 6,000 (political) corpses."

-- **Gravedigger at a Baghdad cemetery, Agence France-Presse, April 21, 2003**

"Rusted from their beds, pulled off the street, yanked from their classrooms and their jobs, essentially abducted by the president's security goons and on the most feeble of pretexts, never again seen by their families and friends. Mourned furtively down through the years by parents and siblings, spouses and children.

"They are the missing, probably long dead and thus mercifully released from their misery. But hope lives on, however atrophied and threadbare. It is this hopeful longing for miracles that brings Iraqis, in their pleading numbers, to every portal, hatchway and unsealed vent hole, in search of loved ones. 'My brother,' says one. 'My son,' implores another."

-- **Toronto Star, April 21, 2003**

"There is nothing in this tunnel, save for rats and sodden fruit crates. But across town, at another portal to the subterranean maze, a morsel of information has floated to the surface. It's a piece of paper, part of a security file. It reads: 'Ali Shankat. Executed criminal. Accused of writing about Saddam Hussein.'"

-- **Report on Iraqi Prisons In the Toronto Star, April 21, 2003**

"Upstairs, accessible by a back stairway only, are about 100 individual cells, dark and windowless, stinking of urine. In one sits a plate of half-eaten food, biscuits and rice, still resting on a green plastic tray. At the end of a hallway lies a pile of bindings and blindfolds.

"An elevator, the only one in the place, leads to the basement and more cells. There are shackles in one room, long cables in another. On another floor there is a small operating room, where some former prisoners said doctors harvested the organs of those who did not survive.

"Finally, out back, stand three portable morgues, metal buildings the size of tool sheds, with freezer units attached. Inside one are six aluminum trays, each the length of a body."

-- **The New York Times, April 21, 2003**

"'I am one of millions who have been tortured,' said 33-year-old Ali Khadem Al Essery, whose knuckles were smashed with a club while he was being interrogated in 1994. Everyone here knows someone who was tortured, and many victims see a bleak future without a measure of justice exacted on the torturers."

-- **Newsday, April 21, 2003**

"Iraq became one of the few nations that legally sanctioned the use of torture in pre-trial investigations, and as a punitive measure. The death sentence was prescribed for a large variety of offenses including usurpation of public money, corruption, insulting the presidency, and treason -- loosely defined. Law became whimsical and contingent on the will of the party and president. Even foreign investments were dependent on the good will of the ruling elite, often tapping into a network of businessmen sanctioned and protected by a Saddam family clique."

-- **Khaled Abou El Fadl, op-ed in the Wall Street Journal, April 21, 2003**

"The picture that emerged of the intelligence service here was of a kind of sadistic shakedown operation, where agents took prisoners to satisfy their masters but extracted money to satisfy themselves.

"Other men returning here said the interrogators had gone even further, demanding sex with female relatives when no money could be paid. In most cases, the prisoners said, bribes were paid, women were offered, but the prisoner remained in jail.

"My family paid them everything we had, \$25,000, and still they did not release me,' Mr. Masawi said."
-- **The New York Times, April 21, 2003**

"Tens of thousands of security files on Iraqis have been found in a huge underground vault beneath the headquarters of Saddam Hussein's most feared secret police agency, the legacy of a Soviet-style domestic spying system that controlled everything from job assignments to whether a person would live or die.

"The files include the mundane -- a man denied the right to leave the country because he refused a job transfer -- and the chilling -- a 19-year-old high school student hanged because he admitted he was the leader of a cell of a banned political party.

"By God, this is everyone in Iraq,' translator George Yousef muttered as he entered the records vault, about twice the size of a basketball court, discovered two days ago by U.S. marines and visited by a journalist Sunday."
-- **Knight-Ridder Newspapers, April 21, 2003**

"Malthan Al Naji had a visit from a United Nations relief team. Anwar Abdul Al Razaq got sick. Zuhair H. Jawa Kubba had American dollars in his pocket. Jawad Abdul Al Naby smuggled some sheep. Because these things happened, these men were beaten with steel rods, had electrodes placed on their genitals, were hung from their arms until their shoulders were dislocated, were suspended by their ankles over the stone floor of a cell while their torturers whipped them with electric cables and pulverized their knuckles with wooden clubs."
-- **Newsday, April 21, 2003**

"Dr. Jinan Al Sabagh, a surgeon at Basra's Teaching Hospital, remembers the day in 1994 when the Baath Party came to the hospital with groups of men who were said to be deserters. The doctors were told to slice off the men's ears.

"It was definitely obligatory,' said Al Sabagh, a gentle man in his 60s who seemed close to tears as he struggled to describe what happened those three days. 'If you didn't, you would have the same thing done to you.

"They made four groups of doctors, one for each day,' Al Sabagh explained. "I was in the fourth group. One doctor here refused and they said if you didn't do it we will do the same to you. He did it."
-- **Newsday, April 21, 2003**

"The relatives push forward, waving their faded pictures, in much the same way that desperate kinfolk had wandered around the ruins of the World Trade Center towers after 9/11, seeking information about their missing. Haid Ahmed holds up a photograph of his brother, Moayed, an agriculture student who disappeared in June, 1981. 'We haven't been able to search for him until now. We were too scared even to try.' Too scared, in the Saddam days, to even inquire about Moayed's fate.

"My brother could be anywhere. This is just a possibility. But any place I hear there is a prison, I go there. I have been to four prisons already. I am going to keep looking because my father and mother have asked me to. We have talked about him every day since he was taken. His life inside prison is now longer than his life outside. In my heart, I think he is alive, but only God knows."
-- **Toronto Star, April 21, 2003**

"I am still afraid," he murmured. "Saddam is alive and so are all those closest to him. We don't know if one day the regime will come back. Those who did this to me are still around. We just don't know their faces. They just took off their uniforms and went home. They are still out there and we are still afraid."

-- **Mutilation victim quoted in The Sunday Times (London), April 20, 2003**

"After he arrived in Baghdad, he was placed in a darkened room with only a small red light, no bed. Guards would splash buckets of water through a small gap in the bottom of the door to put an inch or two of water on the floor so that he could not sleep. They gave him tea and a piece of bread for breakfast. Rice and a piece of bread for lunch. He went to the bathroom in his room, on the floor."

-- **The Baltimore Sun, April 20, 2003**

"In a pile in one of the rooms used for torture were textbooks for children: a science book for third-graders, an agriculture book for sixth-graders. Whole families, including infants and toddlers, were held in this prison. This was a form of mercy, this keeping the families together."

-- **The Baltimore Sun, April 20, 2003**

"In the night, they took me again to the room, and they made my body wet with water. I was naked," he recalls, and now is when he searches with his eyes for that spot. To cushion his words: They used clamps to connect electrical wire to his genitals and then they sent a current running through him.

"My whole body shook," he says. "I was shouting to them, 'I will sign anything! Just stop this!' I was shaking, shaking. I shook until I passed out."

"The guards shocked him in the same way every night for two weeks. When they feared he would die, they gave him a week off. Then back to the shocking. Always they beat him, sometimes on his back, sometimes on his legs and arms, often on the soles of his feet until they bled. The pattern continued for six months."

-- **The Baltimore Sun, April 20, 2003**

"He described how, clad in black garb that covered all but his eyes, he had often meted out sentences in the street, in front of a victim's family and horrified onlookers. Guarded by armed colleagues, he used to tie up and blindfold the accused. One of his men held the detainee's head in a firm grip. Another forced open the mouth.

"Ali would then draw out a pair of pliers and a sharp knife. Gripping the tongue with pliers, he would slice it up with the knife, tossing severed pieces into the street. "Those punished were too terrified to move, even though they knew I was about to chop off their tongue," said Ali in his matter-of-fact voice. "They would just stand there, often praying and calling out for Saddam and Allah to spare them. By then it was too late.

"I would read them out the verdict and cut off their tongue without any form of anaesthetic. There was always a lot of blood. Some offenders passed out. Others screamed in pain. They would then be given basic medical assistance in an ambulance which would always come with us on such punishment runs. Then they would be thrown in jail."

-- **Fedayeen Saddam member interviewed in The Sunday Times (London), April 20, 2003**

"Ferass Adnan is a 23-year-old trader who speaks with difficulty these days now that part of his tongue is missing. Some months ago he got into a fight in a market in northern Baghdad and was overheard insulting Saddam as the 'son of a dog'. A policeman tried to arrest him, but Adnan fled.

"Within hours, Iraqi secret police agents arrived at Adnan's home and, failing to find him, took away his uncle, brother, and two cousins. They were thrown in jail and tortured with electric shocks.

"It was only a matter of days before the regime's ubiquitous security spies caught up with Adnan in the suburbs of Baghdad. He was jailed and then, on March 5, turned over to the specialists of Ali's punishment squad. Adnan was taken back to his father's home in north Baghdad, where his entire family was ordered to gather outside the local coffee house.

"His hands were tied and his eyes blindfolded,' the young man's father, Adnan Duleimi, recalled last week. 'I had not seen my son since they had arrested him. I tried to pay for his release. I lost all my savings, handing everything I had to corrupt security officers who promised to help but only took my money. There was nothing I could do. I had to watch in silence as they took a knife to my son's tongue. Had I said a word we would all have been killed."

-- **The Sunday Times (London), April 20, 2003**

"One of Ali's fellow fedayeen lost his tongue simply for repeating how he had heard of a man who had accused Uday of bringing shame on the Iraqi people for dressing in multi-coloured shirts . which, according to the critic, made him look like a woman.

"There was no mild form of criticism when it came to Saddam, Uday or the regime,' said Ali. 'Any critical comment, even to say that the president looked tired in a speech, was enough to risk having one's tongue cut off by us."

-- **Interview with a member of the Fedayeen Saddam in The Sunday Times (London), April 20, 2003**

"Former prisoners of ousted president Saddam Hussein's government are everywhere in Basra, standing on street corners waiting for water, rummaging through papers in the headquarters of the once feared secret police, sitting quietly at home on a hot afternoon. These are the tortures they describe, and more: a prisoner forced to sit on a heated metal stove, electric shocks applied to genitals, a small blade used to slash a prisoner's back. Even doctors became torturers; they cut off army deserters' ears. Servants of the system fell victim to it, too: police officers and prison guards arrested, tortured, then sent back to work. Torture was considered so routine that many former prisoners shrugged at first when asked about it. 'Of course, they tortured me. Beating people here is something regular,' said Malthem Najj."

-- **The Washington Post, April 19, 2003**

"Anwar Abdul Qadir was there, too, looking. He has been missing his brother since 1991 as well, when the 17-year-old was taken from their home at 4 a.m. His uncle is also missing, and his cousin was executed in 1996. Altogether, he has six relatives who were arrested and whose whereabouts are unknown. 'I'm very lucky they just took five or six relatives,' he said, nodding in the direction of Abdul Wahab. 'Some people had five or six brothers taken."

-- **The Washington Post, April 19, 2003**

"I saw thousands killed and buried in mass graves. Some were lined up and machine-gunned before being covered with sand. Others were just buried alive. Saddam had a programme of telling villagers (Kurds) they were being relocated south. We would take trucks that would normally hold 12 to 15 people and put in 200 with no water or ventilation. Many would die on the way. Survivors were driven to Al Anbar or Tharthar and buried alive in vast holes dug in the ground. I saw thousands of people . men, women and children . die this way."

-- **Defecting colonel in Iraqi internal security service, Evening Standard (London), April 17, 2003**

"Adnan Agari, who never returned, was taken away with his brother Ghassan and his cousin Khatar. They were taken to Baghdad and tortured with electrified wire, Ghassan said. 'The screaming terrified me,' he recalled of the dark, poorly ventilated torture chamber. 'I was a boy then, 15. I have never heard anything like that before or since."

-- **The New York Times, April 17, 2003**

"There in the corridor were the punishment units where men were stuffed into windowless cinder block cells, one metre by 50cm. On the left was the yellow holding pen where prisoners fought to sleep next to the open pits that served as latrines, suffering the stench for a few inches more space."

-- **The Guardian (London), April 17, 2003**

"At least three massacres on Saddam City's streets have occurred in the last 10 years, including 700 people gunned down during a 1998 Shiite demonstration, said Muhammad Qadim Saadoun, a former air force helicopter pilot whose 40-day political imprisonment ended last week with the U.S. entry into Baghdad.

"He said he was imprisoned repeatedly for refusing to fire on his fellow Shiites, who form the majority of the population but had long been subservient to Mr. Hussein's Sunni-dominated secular government.

"You cannot imagine the horrible things they did to us,' Mr. Saadoun said. He was tortured while hanging upside down by his feet and pistol-whipped so hard he has lost some of his memory."
-- **The Dallas Morning News, April 17, 2003**

"Another former prisoner from Saddam City, Hussein Ali, said he was arrested for participating in the 1998 protest and imprisoned until late last year. During torture sessions, his fingernails were yanked off his fingers. He described his cell as 'a big hole with lots of insects and worms.'
-- **The Dallas Morning News, April 17, 2003**

"For days now, scores of desperate Iraqis have turned up outside the state security complex here, searching for their missing loved ones, begging the American troops who guard its gates to help them find the relatives whom they believe to be trapped in a prison beneath the sprawling grounds.

"With the fall of Saddam Hussein's government, 30 years of buried history is slowly being resurrected. The Iraqis who appear each morning calling out names and dates of arrest are hoping that their missing brothers, sisters, aunts and uncles will be resurrected along with the past.

"They hold up one finger, two fingers, four fingers, trying to explain to the Americans how many relatives are supposedly in the jail. They throng the gates from dawn to dusk, holding up photos of their vanished loved ones and holding desperately onto hope."
-- **The New York Times, April 17, 2003**

"One of the disappeared is the son of an old man named Kadem Agari Albadri. He lives in a walled-compound on Maerifa Street, the street of knowledge, landscaped with ficus and palms. His name appears in the book as a local teacher. His son Adnan is there, also: No. 32, arrested March 3, 1991. Suspect. Whereabouts unknown.

"... Much of his family and friends gathered today to hear him speak. They all brought faded pictures or names scribbled on scrap paper of sons and brothers who have disappeared. They need look no further than the book.

"Before anything, I want to tell the people of America and Britain something,' Mr. Albadri said. 'There is nothing, nothing more terrible for a father and mother than to have their child taken from them. Not to know. Never to see his body. You cannot imagine. This is how we lived.'
-- **The New York Times, April 17, 2003**

"I was sitting outside my father's house in a village near Tikrit on Friday when two carloads of fedayeen stopped. They got out and began to beat me and accuse me of being a saboteur. Then they shot me in the leg. They took me to the police station and kept me for three nights, saying they would kill me. Then yesterday they just disappeared. And at 7am this morning (Monday) an American Marine came and let me out of my cell. I feel very lucky."
-- **Khalid Jauhr, an Iraqi Kurd, in the Daily Mail (London), April 15, 2003**

"When they came closer, I could see in the bus men, women and children with blindfolds over their eyes. I was very afraid and hid in a hole. It was mostly men. There were about eight children and ten women. They (Ba'ath Party forces) took them off the bus and led them over to the hole in groups. They sat or knelt and then they began

to shoot them from very close, many shots. Some were just pushed in and then covered up with earth. There was no escape, it was done very quickly.

"I could not tell this secret because I knew it was dangerous knowledge that I should not hold, dangerous knowledge. But if the British Army want me to show them I will dig up the bodies myself, because I know they are there. I can never forget."

-- **Satar Al Khalid, a Bedouin, recalls an incident he saw near Ramallah, Iraq, in 1998, Daily Mail (London), April 14, 2003**

"'Me.' 'Me.' 'Me.' they murmured in response to the question: Whose father, brother, son had been executed by Saddam Hussein's government. Eleven hands in all, raised in the stagnant air inside the low mud-brick house of Sheik Kathem Al Wafi, signalling the death toll here.

"These men and their sheik, the elders of the Al Wafi tribe, are people of the Madan, the marsh Arabs who for five millennia lived in a vast area of wetlands that began about 50 miles north of Basra. I lived, that is, until 1988, when Hussein's government began a systematic campaign of oppression, execution and internal exile against them."
-- **Newsday, April 14, 2003**

"The few Iraqi men of Pumping Station No. 1 tried to protect it as if it were their own. In the end, they lost tools, spare parts and important records to gangs ransacking the oil complex. But they saved the new red fire engine; a quick-thinking operations manager drove it home.

"Over the weekend, the men sat silently, their faces clouded with doubt and fear, as an American oil engineer tried to convince them the station - and the oil flowing through it - really do belong to them and the Iraqi people.

"Under Saddam's regime, the workers said, the station was a place where they had to be careful in their work and careful what they said. On the payroll as a mechanic was a Baath Party official whose real job was to ensure loyalty to the Iraqi dictator.

"Any workers who complained 'would disappear in the night,' said Muslim Yehia, a technician. 'We don't know if they were killed or tortured or ran away.'
-- **USA Today, April 14, 2003**

"Prisoners were taken to watch executions; anyone who cried was executed, too. Our hands were tied like this. First the left hand and then the foot. Then a black hood on my head, then they applied electricity."

"They had a game: They made people drink gasoline, then put them out in open ground and fire guns at them."
-- **Abdallah Ahmed, survivor of Abu Ghraib Prison, on CBS Evening News, April 14, 2003**

"I was beaten, refrigerated naked and put underground for one year because I was a Shiite and Saddam is a Sunni," said Ali Kaddam Kardom, 37. He said he was arrested in the central city of Karbala on March 10, 2000. He returned to the facility in Baghdad this weekend, he said, to help rescue any Iraqis who still might be imprisoned there."
-- **USA Today, April 14, 2003**

"An Iraqi soldier, who according to the facility's records witnessed the beatings, said interrogators regularly used pliers to remove men's teeth, electric prods to shock men's genitals and drills to cut holes in their ankles.

"In one instance, the soldier recalled, he witnessed a Kuwaiti soldier, who had been captured during the 1991 Persian Gulf War, being forced to sit on a broken Pepsi bottle. The man was removed from the bottle only after it filled up with his blood, the soldier said. He said the man later died.

"I have seen interrogators break the heads of men with baseball bats, pour salt into wounds and rape wives in front of their husbands," said former Iraqi soldier Ali Iyad Kareen, 41. He then revealed dozens of Polaroid pictures

of beaten and dead Iraqis from the directorate's files."
 -- USA Today, April 14, 2003

"Saturday, former prisoners and Iraqi soldiers said they heard screams of 'help' from men who were still there. Several soldiers who tried to enter the underground prison through a manhole said they found the area flooded and doors locked. Kanan Alwan, 41, who worked in the facility's administrative office, said the intelligence officers of the facility programmed the prison's computers, which control the water flow, so that the water level would exceed the height of the prison doors.

"They are drowning in there, and there's nothing we can do for them," Alwan said. "The real criminals fled. But the innocents who probably did nothing wrong have been condemned to death."
 -- USA Today, April 14, 2003

"They took my brother in 1998," said Sabah Al Wafi, 24, a relative of the sheik, "and they executed him. I was arrested later. I had a letter from a Kuwaiti prisoner of war, one of 605 Kuwaitis still recorded as missing from the 1991 Gulf War, and they found it when they searched my house. They tortured me with electricity. They made me sit on hot metal plates. They used to drink and laugh as they tortured me."
 -- Newsday, April 14, 2003

"The ordeal of one...victim of the secret police, a woman identified only as Lalla, is recounted in A Book of Cruelty: An Attempt to Spoil What Has Remained of Your Lives, by Amer Badr Hassoun. According to Hassoun's account, the woman, a young law professor, was taken into custody for refusing to join the Baath Party. She was transferred from a Baghdad prison to a series of prisons in the north before ending up at the Baghdad security directorate. One of her torturers there was a former student who kicked her and administered electric shocks before killing a 13-year-old boy who was also a prisoner. During one torture session, she passed out and was taken to the adjoining Security Hospital and subsequently to the nearby al-Kindi Hospital. She was threatened with execution if she spoke of her torture to doctors or nurses. When a doctor asked her if she had been tortured, she responded with silence.

"She was later tried by a judge named Awwad al-Bandar on the charge of not joining the Baath Party. After being refused permission to represent herself, she was convicted and given a life sentence. She was ultimately released during one of Hussein's amnesty declarations and later told her story to Hassoun. Her current whereabouts are unclear."
 -- Knight-Ridder Newspapers, April 14, 2003

"Some former inmates say that in the 1990s, the prison became so crowded, Saddam's son, Uday, ordered hundreds executed to make room for more."
 -- Dan Rather, CBS Evening News, April 14, 2003

"Sheikh Lami Abbas Ajali looked around at the small cell where he spent several bleak weeks of his life and recounted the torture: How he was hit, prodded, had his eyelids pulled back, electric shocks applied to his temples and genitals, how he was handcuffed with tight manacles and then lifted into the air from behind.

"He recalled Saturday how torturers stuffed 10 suspects into an eight-foot by six-foot room so only two could sleep at any given time while the other eight were forced to stand. And how he was kept blindfolded, never quite sure where he was, where they were taking him, what would hit him next."
 -- Gulf News on line (UAE), April 14, 2003

"Hassan Ali Rasan has clawed for days in the rubble of the Detention and Security Center, searching for a piece of hope. Amid twisted wire, bricks and unexploded rocket-propelled grenades, Rasan hunts for traces of his cousin Kasem, missing for 12 years since Saddam Hussein's agents paid him a visit when he was a student.

"He's an only child. His mother cries every time she thinks of him," explained Rasan, 25, a muscular ex-soldier who on Sunday patiently picked through documents and files that litter the crumbled torture chamber, blitzed by U.S. warplanes two weeks ago.

-- Knight-Ridder Newspapers, April 14, 2003

"They wandered the abandoned corridors of one of the most frightening buildings in the Middle East searching for their brothers, desperately trying to ignore the logic that told them there was little hope of finding them alive. Other searchers were lifting trapdoors and banging pipes and marble tiles trying to find the underground cells reputed to hold hundreds of political prisoners under the ominous headquarters building..."

-- The Australian, April 13, 2003

"The male warders made her wear pants, an offense to Shiites' strict female dress codes; without a belt they often fell down. The low point of every day was the daily torture session; the high point, gruel in a bowl, the prisoners' only meal. Even that was denied her if "I made some mistake." Hashmia's jailers scored her back with a hot poker, beat the soles of her feet with sticks, made her pull up her baggy pants and whipped her legs. The sexual humiliation may have been even worse than the pain, but that was serious. 'They slapped me so hard that my neck hurts from it even now.' The torturers wanted her to confess to plotting against the Baathist regime, but she knew that would mean a death sentence."

-- Newsweek on line, April 12, 2003

"U.S. soldiers with tanks and armoured vehicles took over the sprawling compound of Baghdad's military intelligence headquarters on Friday after local people thronged the compound searching for missing relatives.

"Reuters correspondent Khaled Yacoub Oweis said he heard one explosion. It was not clear what caused it. Earlier, Iraqi civilians had been digging feverishly, saying they believed relatives were trapped in underground dungeons used by Saddam Hussein's feared security apparatus."

-- Reuters, April 11, 2003

"Coalition forces have discovered an abandoned military prison here, where discarded gas masks and used atropine injectors suggest the recent presence of chemical weapons and human testing. ... There was no sign of what happened to the inmates and no indication of what their crimes were. But the punishment seems to have been severe. ... There is also evidence of crude torture. Electric cords snake through a tiny window in one cell, the frayed ends dangling from an anchor in the ceiling. Similar sets of wires trail into other concrete rooms. ... 'I'd hate to think of what those clamped onto,' said one U.S. soldier, who speculated the far end would be attached to a generator. 'It's just evil in here.' ... At least a half-dozen gas masks were scattered near the prison's entrance and inside one of the wire-enclosed walkways of the white cinder-block prison. There were also several spent auto-injectors of atropine, a powerful drug that is administered as an antidote to nerve gas."

-- The Washington Times, April 11, 2003

"The Baath Party completely dominated life in Iraq. Until this week, every neighborhood had a Baath official who kept tabs on the area, ran a network of informants and recruited members into the party, say Iraqis. It wasn't difficult to figure out who they were: They had the best cars and the nicest houses and they had money to throw around."

"It didn't take much to run afoul of the party. A wrong word or chance comment within earshot of an informant often was enough to earn an interrogation or worse, according to residents of southern Iraq. There was little accountability, charges were difficult to counter and informants were eager to turn in 'troublemakers' to prove their own value."

"Ordinary people living in this kind of pressure cooker, where any misstep could be fatal, generally avoided sharing their true feelings with anyone but their closest friends and relatives. Making sure children didn't say an errant word before they understood the implications was also an essential survival tactic. 'You only talked when you were sitting with your very, very closest friends,' said Raheem Khagany, 24, an assistant engineering professor. 'If a Baath member heard you, you could be executed.'"

-- Los Angeles Times, April 11, 2003

"...[S]ecret police thugs brutalized even senior officials of the Information Ministry, just to keep them in line (one such official has long been missing all his fingernails). One Foreign Ministry officer told me of a colleague who, finding out his brother had been executed by the regime, was forced, as a test of loyalty, to write a letter of congratulations on the act to Saddam Hussein. An aide to Uday once told me why he had no front teeth: henchmen had ripped them out with pliers and told him never to wear dentures, so he would always remember the price to be paid for upsetting his boss."

-- Eason Jordan, CNN chief news executive, in *The New York Times*, April 11, 2003

"U.S. soldiers with tanks and armoured vehicles took over the sprawling compound of Baghdad's military intelligence headquarters on Friday after local people thronged the compound searching for missing relatives.

"Reuters correspondent Khaled Yacoub Oweis said he heard one explosion. It was not clear what caused it. Earlier, Iraqi civilians had been digging feverishly, saying they believed relatives were trapped in underground dungeons used by Saddam Hussein's feared security apparatus."

-- Reuters, April 11, 2003

"The Baath Party completely dominated life in Iraq. Until this week, every neighborhood had a Baath official who kept tabs on the area, ran a network of informants and recruited members into the party, say Iraqis. It wasn't difficult to figure out who they were: They had the best cars and the nicest houses and they had money to throw around. ... It didn't take much to run afoul of the party. A wrong word or chance comment within earshot of an informant often was enough to earn an interrogation or worse, according to residents of southern Iraq. There was little accountability, charges were difficult to counter and informants were eager to turn in 'troublemakers' to prove their own value. ... Ordinary people living in this kind of pressure cooker, where any misstep could be fatal, generally avoided sharing their true feelings with anyone but their closest friends and relatives. Making sure children didn't say an errant word before they understood the implications was also an essential survival tactic. 'You only talked when you were sitting with your very, very closest friends,' said Raheem Khagany, 24, an assistant engineering professor. 'If a Baath member heard you, you could be executed.'"

-- Los Angeles Times, April 11, 2003

"Naji Abbas headed out for a couple of hours one day in 1985 to buy some medicine and never returned. Thirteen months later, family members say, the police told them they could pick up his body at the Abu Ghraib prison near Baghdad. Abbas, who, according to relatives, was guilty of nothing more than being a Shiite Muslim in Sunni-ruled Iraq, had been tortured, an eye poked out, an arm broken and his chest burned with electrical wires. The regime of Saddam Hussein then delivered the clincher: Family members were asked to pay 30 dinars, a month's wages, for the bullets that killed him."

-- Los Angeles Times, April 11, 2003

"...in the mid-1990's one of our Iraqi cameramen was abducted. For weeks he was beaten and subjected to electroshock torture in the basement of a secret police headquarters because he refused to confirm the government's ludicrous suspicion that I was the Central Intelligence Agency's Iraq station chief. CNN had been in Baghdad long enough to know that telling the world about the torture of one of its employees would almost certainly have gotten him killed and put his family and co-workers at grave risk."

-- Eason Jordan, CNN chief news executive, in *The New York Times*, April 11, 2003

"Two men yesterday gave eyewitness accounts of the execution last Saturday of a commander of the Iraqi 29th brigade after he recommended retreating from Sheykhani, a frontline town that fell to US and Kurdish forces at the weekend.

"He was made to stand in a ditch for half an hour or so and then he was shot," said Salah Mehdi Taleb. The man who shot him was Mahmoud Taher, who also gave us political education."

-- **The Financial Times (London), April 10, 2003**

"In another neighborhood, a group of some 100 children, clothed mostly in rags and newly released from one of the regime's prisons, hugged and kissed the Marines who had freed them."

-- **The Washington Post, April 10, 2003**

"I am from the city of Kirkuk and for the last ten years I have been unable to return to my home there because of Saddam. Seven of my relatives were executed there by his security police when this war started. But God willing and with the help of Britain and the United States I can go back home now and live in peace."

-- **Prshing Mohamed, Iraqi Kurd in Northern Iraq, In the Daily Mail (London), April 10, 2003**

"One middle-aged man held up a huge portrait of Saddam and used his shoe to beat the face of the Iraqi leader, a particular insult. 'This man has killed 2 million of us,' he yelled as bystanders milled around approvingly.

"The looters roamed unhindered through police stations, government ministries and other buildings. A favorite spot was the Al-Sinaa sports complex that held thousands of new athletic shoes and was alleged to be the site of an Iraqi torture chamber."

-- **Orlando Sentinel, April 10, 2003**

"For five years Hashim, a teacher of English at a local secondary school, was held in an Iraqi prison and tortured. His scarred arms bore witness to how, he said, he was strung from the ceiling and beaten by members of the Iraqi secret services.

"I had refused to join the party. They hit me a great deal and I was made to eat my meals like a dog with my hands tied behind my back. But I knew I could never join the Baath Party. How could I and keep my conscience clean?" he said.

"If you want to stay out of trouble you have to join, and then you could be promoted in the party from the street level to representing the city. But then take part in beatings and the burning of property of the people they don't like. I was one of the people they didn't like."

-- **The Irish Times, April 8, 2003**

"Perhaps saddest were two rooms, each hardly bigger than a normal bedroom, reserved for children; they had been crammed with scores of kids from 12 to 16 years old, say the former inmates. Ali Nasr, 13 at the time, was caught up in a sweep when Shiites throughout Iraq rioted after the murder of their Grand Ayatollah, Mohammed Sadiq al-Sader (also called Sader II) in Najaf. ... Ali spent six months in the juvenile wing of Unit Four, sleeping on his feet when the cell was too crowded to lie down, or taking turns on the floor with other prisoners. The boy was still too scared to talk about it, even now."

-- **Newsweek on line, April 8, 2003**

"Former United Nations worker Vanessa Lough said children as young as four have been taken from their parents during the night over the past fortnight and murdered after extremists targeted families thought to have been helping the Coalition forces.

"Some children were hanged as their helpless parents were forced to watch," said Ms Lough, 37. She heard of the atrocities during a water drop on the outskirts of Basra, Iraq's second largest city and a Ba'ath party stronghold. 'In one street alone, they said three children could at one point be seen hanging from the lampposts and around the corner another child lay burned on the road. Parents and children who resisted were badly beaten.' Ms Lough said that, at first, the three women, all middle-aged, were reluctant to talk about what they had seen for fear of persecution.

"They were genuinely afraid for their lives," she added. "Through what I can gather, they knew of at least 11

deaths but said there were many more elsewhere in the city."

"One of the ladies said Ba'ath party leaders and several henchmen had ordered and carried out the killings after their headquarters were bombed last week. It was their way of getting back. One of the men told a father his son was being killed because the father had been seen laughing with several men from the British Army that day. They told him he had "betrayed" Saddam in an act of treason. He received a broken leg and a severe beating. The men made the father watch as they set his son alight with petrol."
 -- **The Mail on Sunday (London), April 6, 2003**

"Haydar, who played 12 years on Iraq's junior and senior national teams, said the troubles started in 1986, when he joined professional team al-Rashid, which was owned by Hussein. When the team lost, Haydar said, players were imprisoned for several days.

"I was tortured for the first time in 1993, after the Iraqi national team lost 2-0 to Jordan," Haydar told ESPN.com. ... A few months later, when Haydar suggested he might not be able to play because of a bleeding ulcer, he was arrested at his home at 2:30 a.m. and sent to prison.

"He took me right to the Olympic prison, where the guards whipped my feet 20 times a day for three days," he said. "They gave me nothing to eat or drink other than a daily glass of water and slice of bread. Then they sent me to al-Radwaniya for four more days of punishment, and this time, I got the full treatment.

"They took my clothes off, laid me down on my back and dragged me by my legs across hot pavement until my back was a bloody mess. Then they made me roll in the sand. And just to make sure that the wounds got infected, I had to climb a 15-foot ladder and jump repeatedly into a pit of sewage water filled with blood and who knows what else. All because I wanted to stop playing soccer."
 -- **The Miami Herald, April 6, 2003**

"A burly 39-year-old man named Qifa, assigned by Mr. Hussein's Information Ministry to keep watch on an American reporter, paused at midmorning, outside the inferno that had been the headquarters of Iraq's National Olympic Committee, to ask the reporter to grip his hand. The building, used to torture and kill opponents of Mr. Hussein, had been one of the most widely feared places in Iraq.

"Touch me, touch me, tell me that this is real, tell me that the nightmare is really over," the man said, tears running down his face."
 -- **New York Times, April 4, 2003**

"Ahmed [writer Ahmed Shawku] went to prison again in 1997. This time, it was his second collection of short stories that did him in. The government had approved the book, but Ahmed sneaked into one of the stories a poorly veiled allegory criticizing Hussein.

"The Mukhabarat was not amused. Agents collected the entire 1,000-copy print run from the Mosul bazaar, piled the books on the ground and ordered Ahmed to torch them. After that, all he needed to do to make things right for the regime was to serve nine months of solitary confinement in a rat-infested cell."
 -- **San Francisco Chronicle, April 2, 2003**

"Former Iraqi weightlifter Raed Ahmad, who defected to the U.S. during the 1996 Games in Atlanta, told the Daily News that athletes are routinely deprived of food and sleep, and the soles of their feet are caned. They are chained to walls for days, he said, and sometimes thrown into tanks filled with raw sewage."
 -- **The Daily News (New York), April 2, 2003**

Senator INHOFE. I am also outraged that we have so many humanitarian do-gooders right now crawling all over these prisons looking for human-rights violations while our troops, our heroes, are fighting and dying. I just don't think we can take 7 bad people—there are some 700 guards in Abu Ghraib, there are some 25 other prisons, about 15,000 guards all together, and 7 of them did things they shouldn't have done, and they're being punished for that. But what about some 300,000 troops who have been rotating through all this time, and they have—all the stories of valor are there.

Now, one comment about Rumsfeld. A lot of them don't like him. I'm sorry that Senator McCain isn't here, because I just now said to him, "Do you remember back 3 years ago when Secretary Rums-

feld was up for confirmation? I said, "These guys aren't going to like him, because he doesn't kowtow to them, he's not easily intimidated." I've never seen Secretary Rumsfeld intimidated. Quite frankly, I can't think of any American today as qualified as Donald Rumsfeld is to prosecute this war.

Now, all the ideas about these pictures. I would suggest to you any pictures—and I think maybe we should get direction from this committee, Mr. Chairman, that if pictures are authorized to be disseminated among the public, that for every picture of abuse or alleged abuse of prisoners, we have pictures of mass graves, pictures of children being executed, pictures of the four Americans in Baghdad that were burned and their bodies were mutilated and dismembered in public. Let's get the whole picture.

Now, General Taguba, many, many years ago I was in the United States Army. My job—I was a court reporter. I know a little bit about the history. The "undue command influence" that is the term that you've heard, and I'd like to make sure that we get into the record what that is. I'm going from memory now, but it's my understanding that the commanders up the line can possibly serve as appellate judges. Consequently, commanders up the line are not given a lot of the graphic details, but merely said, as in the case of Rumsfeld, "Serious allegations need to be investigated," and they started an investigation. This is back in January. Now, Rumsfeld said, and I'm quoting him now, "Anything we say publicly could have the impact on the legal proceeding against the accused. If my responses are measured, it is to assure that pending cases are not jeopardized." Do I have an accurate memory as to why they have this particular "undue command influence" provision that we have been following now for five decades, that I know of?

General TAGUBA. Sir, I'm not a lawyer, and—

Senator INHOFE. But isn't that the reason you were called in? I should ask General Smith.

General Smith, isn't that the reason that General Taguba was brought in, in the first place, to keep this from happening?

General SMITH. Yes, sir, to do the investigation and do the fact-finding so that the commanders could make informed decisions on what actions should be taken thereafter. The difficulty in the command-influence piece is that, should General Sanchez, or should I or General Abizaid, say something along the lines that, "We must take this action against these individuals," then that is command influence and down the line those that are making judgment on them would be influenced and biased in their decisions.

Senator INHOFE. That, sir, has not changed over the last 45 years.

General SMITH. That has not changed. That has happened, we have had a number of folks who have had their sentences impacted by command influence.

Senator INHOFE. Mr. Chairman, one last question to General Smith. All kinds of accounts are coming out now and many of them are fictitious, I would suggest. One was about a guy being dragged out of a barbershop—this was in The Washington Post this morning—and blindfolded. They talked about the person doing this and said he had an AK-47. Are our troops issued AK-47s?

General SMITH. They are not, sir.

Senator INHOFE. Thank you very much.

Thank you, Mr. Chairman.

Chairman WARNER. Thank you very much, Senator.

For the benefit of all Members, the subject of the pictures has been raised, and I'd like to address that. In consultation with the DOD over the weekend, the DOD indicated its willingness to cooperate in every way to provide these pictures to the Senate Armed Services Committee. But it occurred to me, in my capacity as chairman, that this issue was a Senate institutional issue—it went beyond this committee—because I think other Senators should be entitled to receive that information in the same way as members of this committee.

I, thereby, asked the Senate leadership, majority, minority, and invited Senator Levin to join me, and we discussed this issue very carefully yesterday. We are seeking the advice of Senate counsel and the respective counsel of the majority/minority leader, and counsel to this committee, and we will before, hopefully, the end of the day, have adopted a procedure by which that transmission of further evidence can come to the whole Senate. We'll focus on how it would be made available to all Senators, and under what conditions, in compliance with Senate procedural rules and to protect the legal interests of all parties involved. Thank you.

Senator BYRD.

Senator BYRD. Thank you, General Taguba, for your report and for your service to your country.

In Friday's hearing before the Senate Armed Services Committee, General Schoomaker, the Army Chief of Staff, said of the prison abuse, "This is not a training issue, but one of character and values." It's becoming clear to me that this abuse wasn't just about values; it was about policies and planning. General Taguba, based on your investigation, who gave the order to "soften up" these prisoners, to give them "the treatment"? Was this a policy? Who approved it?

General TAGUBA. Sir, we did not find any evidence of a policy or a direct order given to these soldiers to conduct what they did. I believe that they did it on their own volition. I believe that we—they collaborated with several MI interrogators at the lower level, based on their conveyance of that information through interviews and written statements. We didn't find any order whatsoever, sir, written or otherwise, that directed them to do what they did.

Senator BYRD. Doesn't the lack of training of our troops for prison duty actually demonstrate a monumental failure in planning for the long-term occupation of Iraq? How else could the military and civilian leadership of the Pentagon explain why this training wasn't even offered?

General TAGUBA. Sir, the training of the Geneva Conventions is inherent every time we—from as a recruit all the way up to my rank level. In terms of these MPs, as far as internment and resettlement, some of them received training at home station and the Mobility Station, and some did not. That was our recommendation, that a mobile training team be deployed to theater to ensure that they are in compliance with training tasks to do that. There was the capacity to do that during the conduct of their operation because there were competent battalion commanders. The battalion

commander at Camp Ashraf was conducting his detention operations to standard. At Camp Bucca—they did that at Camp Bucca, and also Camp Cropper. Somehow it did not pan out at Abu Ghraib.

General SMITH. Sir, I might also mention that this organization, the 800th MP, is a specific task-organized internment and resettlement organization. Their job was this sort of stuff.

Senator BYRD. So you don't agree that there was a monumental lack of planning, that there was a monumental failure of planning for the long-term occupation of Iraq? You don't agree with that?

General SMITH. Sir, I'm—are you talking to me?

Senator BYRD. Yes.

General SMITH. I'm just addressing the specific training issue for the 800th MP that you related to, that this was their task, to come over and do that. I mean, that's what they did as an organization. So they were brought over to conduct internment and resettlement issues.

Secretary CAMBONE. If I may, Senator Byrd, I don't think that the difficulties we found at Abu Ghraib indicate that there was a long-term planning effort. In fact, Major General Ryder, who also did a report, was there specifically for that purpose, "What is the long-term basis for confinement facilities and training and care and so forth?" So, no, there was attention being paid to the longer-term occupation issue.

Senator BYRD. Secretary Cambone, when, if ever, did Ambassador Bremer first raise any concerns about how the military was running prisons in Iraq?

Secretary CAMBONE. Sir, as I said earlier, the broad question of moving detainees through the prison system was a concern of Ambassador Bremer early on. With respect to the specific conditions inside of those facilities, I am not aware of his having raised them. I don't know when that might have been. I do know that—I am told that sometime in the February/March time frame he raised this issue, but I would have to check records for you, sir.

Senator BYRD. Didn't Ambassador Bremer have overall responsibility for what was going on in Iraq?

Secretary CAMBONE. Yes, sir. He was the occupying power, the one in whom that was invested.

Senator BYRD. Shouldn't he have known how Iraqi prisons were being run? Shouldn't he have sounded the alert if he thought that the military was doing something wrong?

Secretary CAMBONE. Again, sir, the working papers that are issued by the ICRC are done at the level of the command that they are investigating, and they don't frequently elevate to that level. They did meet in February 2004, which is the result—the resulting paper is the one that has been distributed. At that time, the ICRC presented to Ambassador Bremer their findings for that previous year. It is my guess it is that point that the specific issues that you're addressing may have been raised by Ambassador Bremer.

Senator BYRD. Do you know if Ambassador Bremer made any recommendations to the DOD?

Secretary CAMBONE. He was anxious that the DOD find a way to, as I've said, move the prisoner detainee more rapidly through the system, provide addresses for the location to the dependents,

and things of that character, that is a general treatment of the detainees within the system in Iraq.

Senator BYRD. Do you know if he made any recommendations with reference to policy?

Secretary CAMBONE. No, sir, not beyond what I've said. Again, his concern would have been for the broad population and assuring that we were moving people through that system, doing what was necessary for interrogations, and releasing those who had either served their time or had no reason for being in custody. He was anxious to see those people returned to their homes and families.

Senator BYRD. My time is up.

Chairman WARNER. Thank you, Senator Byrd. Thank you very much.

Senator Roberts.

Senator ROBERTS. Thank you, Mr. Chairman.

I think my questions are somewhat repetitive. But, at any rate, General, thank you for the job that you've done. Many are called, and few are chosen, and you have done an outstanding job.

In your report, you indicated that the 800th Military Police Brigade had not been directed to change its policies and procedures to set conditions for intelligence interrogations, but you concluded, indeed, such changes had been made at lower levels. Were these changes made at the battalion or the company level?

General TAGUBA. Sir, we didn't find any changes, either at the company or the battalion, or even at the brigade.

Senator ROBERTS. I'm going to repeat the question by Senator Byrd. Did these changes result from orders or direction from the MI unit at the prison?

General TAGUBA. Sir, there were interactions between the guards and the MI at that level.

Senator ROBERTS. But the changes were not policy.

General TAGUBA. No, sir.

Senator ROBERTS. Did you discuss with Major General Miller his recommendation that the MPs and the MI functions be better coordinated to determine exactly what he had in mind? As a follow-up—this is the “Gitmo-ize” question—is there some level of coordination between the MP and the MI units that is permitted by Army regulations? You cited a whole series of Army regulations. General Ryder, I believe, states that we should have a firewall in between the MPs and the military interrogators. But yet General Miller says from his experience in regards to Gitmo that that basically, if not impossible, is actually detrimental, in terms of cooperation; but insists that if you do have that kind of cooperation, you must have leadership, you must have discipline, and you must have training. Were the MI officers at Abu Ghraib familiar with Major General Miller's recommendations?

General TAGUBA. Sir, I cannot answer that. I was not there for the debriefing, nor did I discuss in any detail General Miller's report.

Senator ROBERTS. Did the intelligence officers then at the prison believe that Major General Miller's recommendations had been accepted and adopted? If so, what was the basis of this belief?

General TAGUBA. Sir, I cannot answer that. I was not there, nor did I question whether the CJTF-7 accepted his recommendations or not. I just read his report.

Senator ROBERTS. Okay. General Smith, an order to “soften up” a detainee would not be a lawful order, is that correct?

General SMITH. Sir, that’s correct.

Senator ROBERTS. What legal basis then would a soldier have for following that order?

General SMITH. Sir, none. Especially if you’re an organization of that type and have read any of the regulations. All of them are replete with guidance on humane treatment, as well as a number of fragmentary orders that were put out through General Sanchez telling them that they could not do many of these—or take actions that were inhumane.

Senator ROBERTS. Secretary Cambone, thank you for your appearance. We welcome you to the Intelligence Committee tomorrow.

Some accused of the abuses at the prison claim they were acting under orders from intelligence officers. Do any of the DOD regulations or policies encourage, condone, or permit such acts?

Secretary CAMBONE. No, sir.

Senator ROBERTS. In your review of this matter, have you learned of any local or unit-level policies—I emphasize the word “policies”—that encourage or condone or permitted these abuses?

Secretary CAMBONE. No, sir.

Senator ROBERTS. Were you aware of Major General Miller’s recommendations that MPs set the conditions for the interrogations at the prison? Did you discuss this recommendation with anybody at the CJTF-7?

Secretary CAMBONE. I did not discuss them with anybody at CJTF-7, no, sir.

Senator ROBERTS. What did you understand this recommendation to mean?

Secretary CAMBONE. That there had to be a basis for the transfer of information from those who had custody, on a daily basis, of those who were being interrogated—to those who were being interrogated in order that the interrogators understood personalities, relationships, in order to be able to gain the information that they were trying to gain from the—

Senator ROBERTS. From a pragmatic standpoint, is this a good thing or a bad thing? Is Ryder right, and Miller wrong? Miller right and Ryder wrong? Or is this somewhere in between?

Secretary CAMBONE. While it is written in doctrine, it seems to me doctrine is meant to be adapted to circumstance, and that was what the substance of General Miller’s recommendation was.

Senator ROBERTS. When is the Fay Report going to come out?

Secretary CAMBONE. It’s my understanding—and, General, you can correct me—that he is completing his work in Iraq over this week. He has to go to Germany to see people who have since rotated from Iraq to Germany, and then will come back here to meet others. So we’re looking toward the end of this month and perhaps the first part of June.

Senator ROBERTS. Is the policy in regards to the MP and the MI functions at Gitmo—is this being reviewed for compliance with Army regulations?

Secretary CAMBONE. If General Fay didn't realize that was a subject of his investigation, sir, he is now painfully aware of it.

Senator ROBERTS. Was your encouragement to Major General Miller to inspect the prison in any way prompted or otherwise linked to concerns about any abuse at the prison?

Secretary CAMBONE. No, sir. To the contrary, it was the desire to make certain that we had the proper conditions within those places in order for the information to be gathered.

Senator ROBERTS. When you learned of the abuse, and knowing of the intelligence activities at the prison, did you have any concern about a possible link to the intelligence unit?

Secretary CAMBONE. I understood—it was probably in February—that there were MI personnel who were implicated. I did not know the nature of that implication, the extent or scope of the abuse that had taken place. So I didn't make a connection in the sense that there was a significant issue here until we moved down the path and realized exactly what was taking place.

Furthermore, I still don't know that there is a significant issue here.

Senator ROBERTS. I thank the chairman.

General SMITH. Sir, could I clarify on the MP/MI regulation here? It is not absolutely clear in this regulation that the MPs and the MI guys should not have some relationship. What is absolutely clear in the regulation is that the MPs are not allowed to be in the interrogation process. So do not take it that there is some Army regulation out there that says, "This shall not be." I have it right here, and I'll be glad to provide it for the record.

[The information referred to follows:]

[Deleted.]

Senator ROBERTS. I think that would be helpful. My point was, I don't think you can set up a firewall between those who are interrogating and the MPs. I don't even think that would be desirable. On the other side of the fence, you don't want them directly involved—

General SMITH. Yes, sir.

Senator ROBERTS.—and with the lack of discipline and leadership and training, to have something like this happen.

General SMITH. I agree with you. I believe when you read the document you will see that that allows that sort of activity.

Senator ROBERTS. Mr. Chairman, it would be helpful if we had Secretary Cambone's statement. I don't have that. I don't know if it was made available. He has it now.

Chairman WARNER. It was made available just shortly before the hearing.

Senator ROBERTS. All right, thank you, sir.

Chairman WARNER. It's being reproduced now. Thank you.

I acknowledge, as chairman of the Intelligence Committee, you're conducting a separate inquiry on this matter, but I think it's important—and I picked up on something Secretary Cambone said.

Secretary CAMBONE. Yes, sir.

Chairman WARNER. Do you have any knowledge of any CIA participation in the interrogation process in the cell blocks?

Secretary CAMBONE. I do know that there were people who were brought by CIA personnel to that place, to the cell blocks, and there may be—and, again—there may have been interrogations conducted by the CIA personnel while they were there. That's about the extent of my knowledge of specifically what they were engaged in, in terms of interrogation.

Chairman WARNER. General Smith, do you have any additional knowledge?

General SMITH. No, sir, I do not.

Chairman WARNER. Thank you very much.

Senator Reed.

Senator REED. Thank you, Mr. Chairman.

General Taguba, to the best of your knowledge, when did this pattern of abuse begin, as we've seen in the pictures?

General TAGUBA. Sir, to the best of the evidence that we gathered, it happened sometime after October 15, 2003, thereabouts—

Senator REED. 15th of—

General TAGUBA.—mid- to late-October.

Senator REED. Right.

General Smith, General Miller came to Iraq in August with the baseline from Guantanamo, which had a series of coercive measures, which was being employed in Guantanamo. We all recognized that area was not subject to the Geneva Conventions. He briefed, as you indicated in your previous testimony, individuals at the prison. He also recommended the establishment of a theater JIDC there. Is that correct?

General SMITH. I believe so.

Senator REED. That's correct.

General TAGUBA. Yes, sir.

Senator REED. That was August. Then in October, we start seeing a series of abusive behaviors, which the accused suggest were a result of encouragement or direction from these intelligence people in this theater JIDC. General Taguba has testified that he did not investigate, talk to, or in any way know anything about what was going on in that JIDC. Is that a fair chronology?

General SMITH. Sir, it's a fair chronology. I would only say that in speaking with General Miller, he has to be the one that answers some of this, he spoke directly to the brigade commanders who were involved here, and he had the special operating procedures with him, and left those with them.

Senator REED. General, to your knowledge, General Miller made it very clear to these brigade commanders that because of the Geneva Conventions, many of these provisions could not be applied?

General SMITH. Sir, according to General Miller, that was very clear to the commanders.

Senator REED. That was very clear. Then why would he bring those procedures over and brief them?

General SMITH. Sir, to the best of my knowledge—and, again, these are questions you're going to have to ask General Miller—but, to the best of my knowledge, he did not bring those coercive procedures over with him.

Senator REED. Thank you.

Mr. Secretary, you encouraged General Miller to visit.

Secretary CAMBONE. Yes, sir.

Senator REED. Were you in communication, or anyone in your office in communication, with General Miller during his trip or after his trip?

Secretary CAMBONE. He technically went under Joint Staff auspices, but with my encouragement and that of other senior members of the DOD, to look at the issues that we've talked about. Now, on his return, when he completed his report, I received a briefing on it, and then asked for people to look at its subsequent progress and what had taken place.

Senator REED. So you were briefed on his recommendation to use the guard force actively to condition the—

Secretary CAMBONE. No, sir. Again, the—

Senator REED. You weren't briefed on that.

Secretary CAMBONE. No, no. Excuse me. I want to phrase this right, and that is, on the issue of making certain that we had the kind of cooperative relationships, I understood that. I don't know that I was being told, and I don't know that General Miller said, that there should be that kind of activity that you are ascribing to his recommendation.

Senator REED. General Taguba—excuse me, I'm probably doing violence to your name; forgive me—was it clear from your reading of the report that one of the major recommendations was to use guards to condition these prisoners?

General TAGUBA. As I read it on the report, yes, sir, that was recommended on the report.

Senator REED. But General Miller didn't think it was important enough to brief you, Mr. Secretary?

Secretary CAMBONE. Sir, I was not briefed by General Miller.

Senator REED. Who were you briefed by?

Secretary CAMBONE. My deputy, General Boykin, briefed me on the report.

Senator REED. So General Boykin and General Miller were collaborating on this exercise?

Secretary CAMBONE. Oh, not at all. Not at all, sir. Not at all.

Senator REED. General Boykin didn't think it was important enough to brief you on that.

Secretary CAMBONE. No, sir. Again, your suggestion that the report on the phrase "setting the conditions" is tantamount to asking the MP to engage in abusive behavior, I believe, is a misreading of General Miller's intent.

Senator REED. Mr. Secretary, what I'm suggesting is, anyone in your position should have asked questions. One, specifically, would be, what does it mean to "set the conditions" of these troops, under the Geneva Conventions?

Secretary CAMBONE. Yes, sir.

Senator REED. Did you ask that question?

Secretary CAMBONE. I didn't have to ask that question. Why? Because we had been through a process in which we understood what those limits were with respect to Iraq and what those were with respect to Guantanamo.

Senator REED. Mr. Secretary, what is the status of the detainees in that prison under the Geneva Conventions?

Secretary CAMBONE. I'm sorry, sir, which prison?

Senator REED. Abu Ghraib.

Secretary CAMBONE. Abu Ghraib? They are there under either Article 3 or Article 4 of the Geneva Conventions.

Senator REED. Let me recite Article 4, "Persons protected by the Geneva Conventions are those who, at any given moment and in any manner whatsoever, find themselves, in case of a conflict or occupation, in the hands of a party to the conflict or occupying power of which they are not nationals." These are protected persons.

Let me read Article 31, "No physical or moral coercion shall be exercised against protected persons in particular to obtain any information from them or from third parties."

Secretary CAMBONE. Sir, we're in agreement here.

Senator REED. We're in agreement—I don't think we are, Mr. Secretary.

Secretary CAMBONE. We are in agreement on—

Senator REED. General Miller suggested that guard forces be used to "set the conditions." Based on the template at Guantanamo, those methods were coercive. Yet you did not choose to ask about this. You're completely oblivious.

Secretary CAMBONE. No, sir. Again, what I said was, we knew what the circumstances were with respect to Guantanamo. We knew what the circumstances were with respect to Iraq. We understood that the Geneva Conventions, and all of its articles, applied in Iraq. That—again, I come back to what I keep saying here—the notion was that you had to have a cooperation, a cooperative attitude, team-building, call it what you will between the MPs and—

Senator REED. Mr. Secretary, please.

Secretary CAMBONE.—the MIs.

Senator REED. Please.

Secretary CAMBONE. Sir—

Senator REED. This is not a cooperative attitude. This is not a guard observing the comments of a prisoner.

Secretary CAMBONE. That is exactly true, sir.

Senator REED. That is—is that happening in Guantanamo?

Secretary CAMBONE. No. Sir, what took place—

Senator REED. Is that what's happening in Guantanamo?

Secretary CAMBONE.—what took place in the prison, we have all said, exceeded the regulations, laws, and laws of war, conventions of the Geneva Conventions, and everything else. General Taguba has said repeatedly that there was no policy, he discovered no direction, that these were not directed acts on the part of those individuals—

Senator REED. Mr. Secretary, people failed to ensure, by asking appropriate questions, that these recommendations were transmitted down to individual soldiers in a way that they would understand—

Secretary CAMBONE. Yes, sir.

Senator REED.—this is just—is cooperating, not participating in the "setting the conditions," as was done—as is done in Guantanamo.

Secretary CAMBONE. Senator, I agree with you on the transmission of those directions. As I said to you, and as General Smith has alluded to, there is a paper from General Sanchez making precisely those points. Moreover, if you read General Miller's report, he says, "Before you do anything with this, we need a command staff judge advocate to work this problem and make sure it's done"——

Senator REED. Did a command SJA issue a legal opinion?

Secretary CAMBONE. When—again, what I have is his report, and it says that that was an activity in progress. I have not heard—what I know is that General Sanchez subsequently——

Senator REED. General Sanchez ordered this policy without advice of counsel.

Secretary CAMBONE. No, sir, he did not. If you read General Taguba's report, he will tell you that, at the time he was there, he had not seen any action—it's page 12, I think—to implement the procedures, specifically and officially, from General Sanchez down to anyone in the lower ranks of his command that the activity that was taking place was not authorized.

General SMITH. I would add that there were numerous FRAGOs out there that direct other than what you are suggesting.

Chairman WARNER. Thank you very much. If there's further amplification to the Senator's question, please provide it for the record.

Senator Allard.

Senator ALLARD. Mr. Chairman, I want to thank you for moving forward on this investigation quickly here at the committee level. I think it's something we need to move off our agenda so that we can begin to concentrate on how many good things are happening in Iraq, as far as moving them towards a sovereignty, their own sovereignty. I do have a statement I'd like to have put in the record and I'd ask unanimous consent, prior to my questioning.

Chairman WARNER. Without objection.

[The prepared statement of Senator Allard follows:]

PREPARED STATEMENT BY SENATOR WAYNE ALLARD

Thank you, Mr. Chairman. I would like to thank our witnesses for appearing this morning to help us discuss the allegations that have been raised.

I would like to begin my remarks by reminding us all of the phenomenal progress we are making in the transformation of the Iraqi government. Specifically, the Iraqi Governing Council approved the Transitional Administrative Law (TAL), representing the most liberal basic governance document in the Arab world. As I understand this historic document, it represents an Iraqi "bill of rights," including the assurances for all Iraqis of freedom of religion, freedom of expression, freedom of the press, and freedom of assembly. In addition, this TAL includes fundamental rights for women.

Our progress in Iraq also includes remarkable public works accomplishments. Oil production and power generation now surpass pre-war levels. All 22 universities and 43 technical institutes and colleges are open. Coalition forces have rehabilitated more than 2,200 schools. All 240 hospitals and more than 1,200 health clinics are open. Health care spending in Iraq has increased 30 times over pre-war levels. Additionally, 170 newspapers are being published.

Our military forces are directly responsible for this positive change, and should be commended. These accomplishments, in my mind, are what define the valor, commitment, and compassion of our Armed Forces. It is not the incidents that are the subject of this hearing. Gentlemen, I know you share my frustration and concern over the reported incidents of prisoner abuse involving our Armed Forces.

My frustration comes from believing our soldiers know better than to carryout those activities now splashed all over our public media. Several of my colleagues

and I have been to Iraq and Afghanistan recently, and we have seen the unmatched skills of our soldiers in defeating a hostile enemy, as well as rebuilding a public works infrastructure. Yet, here we are discussing how the misdeeds of a few can overshadow the accomplishments of so many.

My concern comes from understanding that we need to develop and employ all prudent measures to ensure our military men and women, as well as millions of locals, remain safe and secure throughout the reconstruction of this region. Without a doubt, our forces need effective detention and interrogation tools for terrorists, insurgents, and others trying to kill us. Successful exploitation of these enemy combatants will ultimately deny them the opportunity to plan, prepare, or execute more killings. Today, we must examine events that got out of control, and figure out how to realign our people and our practices toward a humane and legal alternative.

Mr. Chairman, it also appears to me that the military has done a good job with investigating these allegations and taking appropriate actions. However, it was disappointing that senior leaders did not recognize and report the serious consequences that the underlying allegations entail. I look forward to your continued leadership, as well as the leadership of SECDEF Rumsfeld, in getting to the bottom of this matter and getting our focus back on the job well done by our security and reconstruction forces.

Senator ALLARD. I'd also share my shock and dismay that Senator Inhofe mentioned, in the fact that this unfortunate situation at Abu Ghraib prison is actually being used as a fundraiser by the Kerry campaign. I just find that appalling.

Now I'd like to move forward and pose a question to you, General Taguba. In my statement, I find that your reporting supports that the Army has taken the initiative in following through appropriately on our own affairs. Just so that I'm clear in my own understanding, were you directed by any of your superiors to remove any findings that you felt were credible or relevant?

General TAGUBA. Sir, I was not directed by my superiors.

Senator ALLARD. Were you directed by any of your superiors to withhold or remove recommendations for any adverse personal actions regarding subjects of your investigation?

General TAGUBA. Sir, none whatsoever.

Senator ALLARD. Just so I'm clear also about the makeup of the prison population, my understanding, from some of the testimony that we've received here today, that if somebody is classified as a terrorist—in other words, they're not associated with any country, officially—then there's a difference; they don't fall under the Geneva Conventions' guidelines. Is that correct?

Secretary CAMBONE. The President designated the al Qaeda as being unlawful combatants, sir.

Senator ALLARD. So just that particular terrorist organization, or any terrorist organization?

Secretary CAMBONE. I know for a fact it's al Qaeda, and my guess is that depending on the circumstances, if we found ourselves in armed conflict with some other organization, such as—the President would take that under advisement.

Senator ALLARD. Okay. Now, did we have terrorists in the population at this prison?

General TAGUBA. Sir, none that we were made aware of.

Senator ALLARD. So as far as we know, these were all related to those guidelines that generally you were complying with, as far as the military is concerned, on how you handle prisoners.

General TAGUBA. Sir, they were either classified as security detainees or "other" detainees—criminals, things of that nature.

Senator ALLARD. But no terrorist classification.

General TAGUBA. None that we were given, no, sir.

Senator ALLARD. Okay.

Secretary Cambone or General Smith, in your estimation why was anyone taking pictures in the security detention facility at Abu Ghraib? Is there any explanation, from a physical security or prisoner security or MI perspective?

General SMITH. Sir, the photographing of prisoners, especially with private cameras, is against—

Senator ALLARD. Private cameras?

General SMITH. By private cameras—is against the rules.

Senator ALLARD. So these were taken by private cameras?

General SMITH. Sir, I believe they were taken by digital cameras that belonged to the individuals, but I don't know that. Maybe General Taguba does.

Senator ALLARD. I see.

General TAGUBA. Sir, they were personal cameras.

Senator ALLARD. They were personal cameras.

General SMITH. This specifically says “photographing, filming, and videotaping of individual EPW/civilian internee, other than internal internment facility administration or intelligence/counter-intelligence purposes, is strictly prohibited.”

Senator ALLARD. So this didn't have anything to do with the way you managed the prisoners or any of their interrogation or any physical security of the prison. This was taken on by individuals, unknown to those in command at the time?

General SMITH. That is my belief, but I don't know—

General TAGUBA. Sir, as far as we know, based on the evidence and the interviews and the statements, they were taken with personal cameras.

Senator ALLARD. Individuals taking that on their own, without any instruction from command.

General TAGUBA. Yes, sir.

Senator ALLARD. Okay.

Now, General Smith, in General Taguba's report he recommended that a mobile training team be assembled and dispatched to your area of operations to oversee and conduct comprehensive training in all aspects of detainee and confinement operations. Were these teams dispatched, as recommended?

General SMITH. Sir, they were dispatched before the report was actually approved. About 50 percent of the training is complete, and they will continue and have all of this completed by the end of June, although everybody who is out there is getting training weekly, awaiting the mobile training team specifically getting down there. That will be followed by sustained required training every week in all of these rules. Additionally, the Geneva Conventions are required to be briefed at every change of shift.

Senator ALLARD. Your point is, is that when you got General Taguba's report, even before it was finalized you were beginning to take corrective action, and so action was—you were responding immediately to concerns about how—what was being reported in the camp at Abu Ghraib.

General SMITH. That's correct, sir.

Senator ALLARD. Okay.

General Smith, General Taguba—I understand the necessity and significance of maintaining a strategic interrogation exploitation process. After all, a primary goal along these lines is to save the lives of Americans, Iraqis, and other partners in the region. Can you share with us whether or not your command is actually developing good intelligence based on your approved interrogation techniques? In other words, are we saving lives?

General SMITH. Sir, my belief is that we are. We absolutely have built the networks and what they look like and who the players are, based on intelligence information from human intelligence (HUMINT). A portion of that is this kind of activity. So, sir, I would say, absolutely, that there have been lives saved because of the people that we have been able to go out and pick up, because of the HUMINT process.

Chairman WARNER. Thank you very much, Senator.

Senator Akaka.

Senator AKAKA. Thank you very much, Mr. Chairman.

General Taguba, I want to commend you and your team for submitting a very, what I consider, a candid and thorough report. Your task was not an easy one. However, your honesty and your integrity reflect the character we expect from soldiers in our military.

General Taguba, in your report, you reference the lack of supervision over U.S. civilian contractor personnel, third-country nationals, and local contractors within the detention facility at Abu Ghraib. During your investigation, did you determine how many civilian contracted personnel were working there? Who supervised these individuals? Can you describe what you observed, in terms of type of access these individuals had to the detainee areas?

General TAGUBA. Sir, we did not make a determination of how many civilian contractors were assigned to the 205th MI Brigade and operating at Abu Ghraib. I personally interviewed a translator, and I also personally interviewed an interrogator, both civilians, contractors. There was also a statement—and substantiated by the witnesses that we interviewed of another translator—a third-country national, in fact, who was involved. There was another third-country national who was acting as a translator for the interrogators, that was involved in one of the interrogation incidents where dogs were used.

Their supervision, sir, from the best that we could determine or discern from the information that we gathered, was, they were under the supervision of the JIDC, who was then under the supervision of one—a lieutenant colonel, who was also supervised by the brigade commander, the MI brigade commander. That was the chain, sir.

Senator AKAKA. What access did these individuals have to the detainee?

General TAGUBA. Sir, they had an open access to the detainees.

Senator AKAKA. General Taguba, your report finds that two contractors were either directly or indirectly responsible for the abuses at Abu Ghraib. Were either of these contractor personnel supervising soldiers or in a position to direct soldiers to take specific actions?

General TAGUBA. Sir, they were not in any way supervising any soldiers, MP or otherwise. However, the guards, those who were in-

volved, looked at them as competent authorities as in the manner by which they described them, as the MI or by name or by function.

Senator AKAKA. Secretary Cambone, what kind of training did the U.S. civilian contractors have prior to going to Iraq? I've been informed that the training for interrogators included training tactics and techniques used by other countries. Did such training occur? If so, are these tactics and techniques approved by DOD intelligence officials?

Secretary CAMBONE. The only tactics and techniques that would be approved, sir, are those that are approved by the command for use in that situation. As I said earlier, the recruitment—and if you look at the advertisements for the recruitment, they look for people who have had the experience of being interrogators. I am told that, in fact, some of the retired personnel and those who have since left the service are quite capable and are, in terms of the interrogator's art, better able to conduct those interrogations than the younger individuals who are new to that activity.

General SMITH. Sir, most have gone through the 19½ week training at Fort Huachuca, either while they were in the service or afterwards.

Senator AKAKA. General Smith, who is keeping a record of all the employees that work for all the contracted firms in Iraq and Afghanistan? Is it the contracted firm or DOD?

General SMITH. Sir, you're beyond my knowledge there, except that the contracting officer who contracts with the company is responsible for ensuring that they comply with the contract. By name, I suspect he has who those contractors are. But I can't tell you that for sure.

Senator AKAKA. Thank you for your responses.

Chairman WARNER. Thank you very much, Senator Akaka.

Senator Sessions.

Senator SESSIONS. Thank you.

I first want to, again, state my appreciation for the superb work of our soldiers in Iraq and Afghanistan. In many, many instances, some of which we've seen on television, they demonstrate restraint day after day. They've maintained their poise and their professionalism sometimes under very intense pressure. They've risked their lives, and we've seen a soldier going to the bridge to save an Iraqi woman under hostile fire. They have, on their off-hours, built schools and hospitals, and treated the sick. So this is particularly painful for all of us, to have this experience.

But I absolutely have visited those soldiers there. They've told me of things that they've done and the relationships they've had with Iraqi citizens. I strongly—it's interesting how many want to volunteer and go back, because they believe in the work and they want to see this to be a healthy, stable country. Nothing we say today should denigrate that.

I have been somewhat concerned at the suggestion that there is a policy of abuse here. General Smith, I think you've read, clearly, that the explicit statements from every level of command are in existence that would absolutely prohibit this kind of behavior, is that not correct?

General SMITH. Sir, that's absolutely correct, in many venues and a number of times where FRAGOs have been republished for

the purpose of doing that. I would like to present those for the record. I know Senator Reed is very concerned about it, and I would like to put those in the record.

[The information referred to follows:]

[Deleted.]

Senator SESSIONS. With regard, General Smith, of the Geneva Conventions, I was in the Army Reserve. I, for a short time, had a Judge Advocate General (JAG) slot, although I'm not like Colonel Lindsey Graham over here, who is an actual practicing JAG officer, but I remember in the transportation unit I had to train the transportation soldiers, enlisted people in the Geneva Conventions. Isn't that done throughout the Army?

General SMITH. Sir, that is. That continues to be a requirement.

Senator SESSIONS. In basic training, every soldier has been trained in the Geneva Conventions, is that not correct?

General SMITH. That's correct, sir.

Senator SESSIONS. I heard you say that they are briefing the Geneva Conventions at every shift change now in Abu Ghraib prison?

General SMITH. That's correct, sir.

Senator SESSIONS. Before that occurred, one of the criticisms I think General Taguba mentioned was, they were supposed to be briefing the Geneva Conventions periodically, but perhaps it was not occurring. Are you familiar with that part of the report and what the requirement was?

General SMITH. I'm familiar with the report.

Senator SESSIONS. General Taguba, you made some reference to the fact that there was a procedure established to train periodically, and it may not have been occurring?

General TAGUBA. Yes, sir. It's required, under AR-190-8, to post the Geneva Conventions in the language of the detainee. So you have many detainees there of different languages. They have to post that. It's a requirement, especially for those units that are conducting internment and resettlement mission requirements. Those guards, in terms of discipline, were supposed to conduct by their own SOP, guard mounts, where you have shifts—you're changing shifts, and you have guard mount. Sir, we found evidence that was not being done. They did kind of a replacement, so to speak, during their shift time, because they were not conducting guard mounts by which they were to reinforce tenets of the Geneva Conventions, or made clear that the postings of the Geneva Conventions were to be made available, not only to the detainees in a language from which they come from, but also where they could see them.

Senator SESSIONS. That was never challenged or rejected by General Abizaid, General Sanchez, or anyone else in authority in Iraq. I mean, those policies were in effect, and amounted to a violation of the established Army policy when that did not occur. Is that correct?

General TAGUBA. Sir, I cannot speak for General Abizaid or General Sanchez, but that's the responsibility of the battalion commander and also those personnel who are conducting internment and resettlement or detention operations. It's clear, it's in their doctrine, it's in the regulation.

Senator SESSIONS. Of course, General Smith, MPs have more of this training than other soldiers, I assume, in how to handle prisoners.

General SMITH. Sir, I can't speak to that, but my assumption would be that certainly they have more training than the average soldier would.

Senator SESSIONS. I thank you for your comments, and would note that—my time is expiring, but this “Gitmo-ize” issue, I think, really misses the point. Yes, we wanted to use some of the procedures that were working in Guantanamo, and try to share that information to get it up to the people in authority so we could save lives, get it out to the people who could use it to identify who these attackers and terrorists were, but I don't think there's any indication that General Miller would in any way suggest this kind of behavior was legitimate.

General SMITH. Sir, you're absolutely right in both counts. In a counter-insurgency like this, intelligence is critical, in that if you want to go find the guys that are making the improvised explosive devices (IED) or the ones who are shooting down helicopters with surface-to-air missiles like SA-7s, or folks who are fomenting the insurgency, then you have to use HUMINT to do that. You can't do that by technical means alone.

Chairman WARNER. Thank you very much, Senator.

General SMITH. So it is a critical piece of the process. Clearly, time and time again, we are told: humane treatment in concert with the Geneva Conventions.

Senator SESSIONS. Thank you, Senator.

Chairman WARNER. That's a very important inquiry and response, and I appreciate that, General.

Senator Bill Nelson.

Senator BILL NELSON. Thank you, Mr. Chairman.

I don't think General Miller is where the problem lies, Senator Sessions. I think it lies elsewhere.

General Taguba, on page 16 of your report you state, “I find that the intentional abuse of detainees by military police personnel included the following acts.” You list a whole number of those acts; among them, videotaping and photographing naked male and female detainees; forcibly arranging detainees in various sexually explicit positions for photographing; forcing groups of male detainees—and I will insert paraphrasing here—certain sexual acts while being photographed and videotaped; a male MP guard having sex with a female detainee; using military dogs, without muzzles, to intimidate and frighten detainees, and, in one case, biting and severely injuring a detainee; sodomizing a detainee with a chemical light and perhaps a broomstick; using military working dogs to frighten and intimidate detainees with threats of attack, and, in one instance, actually biting the detainee. Is that your report?

General TAGUBA. Yes, sir.

Senator BILL NELSON. All right.

Mr. Secretary, when did you become aware of the nature of these prisoner abuses and the existence of the photographic and video evidence? That's two questions.

Secretary CAMBONE. The photographic evidence—be clear—that there were photographs associated with this inquiry, I knew early, in the change of the year. The nature—

Senator BILL NELSON. I'm sorry, I didn't understand.

Secretary CAMBONE. I'm sorry. I understood, at the beginning of this year, that there were photographs associated with the criminal investigative inquiry.

Senator BILL NELSON. Did you know about these acts?

Secretary CAMBONE. I did not know about these acts, and learned of them in specificity when I read the report and when I was exposed to some of those photographs.

Senator BILL NELSON. You read the report when?

Secretary CAMBONE. It has to be in the last week, sir. It was not out of the command until the end of last month.

Senator BILL NELSON. Now, the SECDEF told us last Friday that he learned about these abuses in the middle of January.

Secretary CAMBONE. That we had abuses, true. The nature of them, I was not aware of.

Senator BILL NELSON. Did you know that they were horrific?

Secretary CAMBONE. No, sir. I received a report that there was an inquiry underway—a number of—six or seven, by the way, and this being one of them—in which there were people implicated in abuses of prisoners in Iraq. The character of it, the scope, the scale, I was not aware of.

Senator BILL NELSON. Specific to this prison, what was your role in alerting others that you work for, such as the SECDEF?

Secretary CAMBONE. Yes, sir. Again, as the Secretary testified, corporately we were aware—and I was one of those who told him so—that there were investigations underway with respect to this facility, and ultimately the report that General Taguba's done, in the February time frame. I mean, and so it was a report of an investigation about acts of abuse.

Senator BILL NELSON. What was your role in alerting the SECDEF to the danger posed to our theater strategy and the general perception around the world?

Secretary CAMBONE. Yes, sir, and let me throw out gradations here. There are instances of people having been mistreated in their apprehension, transportation, and interrogation. That was—a level of poor performance and behavior on the part of our people was understood, but it was understood a fairly low level of abuse and incidence—rate of incidence. The scale of this was unknown to any of us. Had we known its scale, scope—the earlier we would have known, the sooner we would have been able to come to you, to the President, and to others to talk about it.

Senator BILL NELSON. You're saying you didn't know about that until last week?

Secretary CAMBONE. Scope, scale—until the pictures began appearing in the press, sir, I had no sense of that scope and scale. I knew of the problem, that there was abuse, that there was a criminal investigation, that there was an investigation being done by General Taguba, but I had no sense of it, sir.

Senator BILL NELSON. Okay, given that fact, why was the SECDEF unprepared when he came before us in the secure room in the Capitol on April 28, 2004—why was he unprepared to share

the information that he knew of with Members—probably some 35 or 40 Members of the U.S. Senate?

Secretary CAMBONE. Sir, I don't—I can't answer for the SECDEF on that question. He was here. He spoke with this committee and gave his answers, I recall. I can't speak for him on why he did not raise it that evening. I don't know.

Senator BILL NELSON. You had not discussed that with him?

Secretary CAMBONE. That day, I had not discussed it with him, no, sir.

Senator BILL NELSON. Had you discussed it with him anytime before, after you learned, in mid-January, about these abuses?

Secretary CAMBONE. Again, I informed him that there were investigations underway, of which this is one of six or seven that I was informed of. I—again, I did not understand the scope and scale. If I had, I assure you, Senator, I would have told him.

Chairman WARNER. Thank you very much, Senator.

Senator Talent.

Senator TALENT. Thank you, Mr. Chairman.

Secretary Cambone, very quickly, one of the things that I've wondered about, when you said you didn't recognize scope and scale, is it possible that not having seen the pictures, you didn't recognize what the significance of the pictures would be, in terms of the impact of this internationally?

Secretary CAMBONE. Yes, sir.

Senator TALENT. General Taguba, your report—I think if we summed it up, we'd say that the unit at the prison was under-disciplined, under-manned, and poorly led. Is that a fair summation?

General TAGUBA. Sir, very fair.

Senator TALENT. In the middle of an Army that I think all of us would agree is very well-disciplined and very well-led. So the question in my mind—well, how? Why is this particular unit so below the standards in performance of the rest of the United States Army? I'm going to make a comment, and you can comment on it if you want. I was in the other body all throughout the 1990s, during which time the highest civilian authorities here and on the other side of Pennsylvania Avenue were cutting the size of the Army, and, in my judgment, not funding adequately what—the end strength that we had remaining. What I saw consistently was the Army, in order to keep the tip of the spear sharp, if you will, allowing some of the rest of the spear to go rusty. Sooner or later, those chickens come home to roost. You have a poor commander, you don't have enough people, the guys you have are not trained up adequately because you don't have the money for it, and then something like this happens. I'll just say, I wish we had had the interest nationally through the 1990s about funding the Army adequately, and maybe we wouldn't all be sitting here.

General Smith, let me ask you a question. I had a phone call, actually, from a constituent who raised an issue that might help in one aspect of this. As I understand it, one of the difficulties with getting this up to the various highest civilian levels is that—the concern about command influence, because the same people that you'd want to report this through and to are the people who would be involved in passing on any court-martials that may emerge from this. I know this is a problem. My wife used to be in the JAG corps.

A constituent let me know that there is an office in the Air Force, the reporting office on special-interest cases, which is evidently designed to deal exactly with this. Are you aware of that office?

General SMITH. Sir, I'm not aware of that office, and this was in basically Army channels.

Senator TALENT. Right. What I'm wondering, and maybe to recommend to the SECDEF, this office exists for—as I am told, and we're checking this out in my office—in the Air Force to deal with cases like this. So you can—if you think something's of special significance, you can get it up to higher authority, but through a separate, specially-created chain of command so you don't compromise the command influence, and then you can get it to somebody who then has the discretion, if they want to, to go directly to the SECDEF or the Deputy SECDEF. We're certainly going to be looking—and I'd recommend it to you, if you're not aware of it, because evidently it functions pretty well in the Air Force. You're not aware of it, though, as of now, I take it.

Secretary CAMBONE. Now that you mention that office, yes, I recall that there is one, and I can tell you that the SECDEF has more than that on his list of ideas—or will have more than that on the list of his ideas.

Senator TALENT. Okay.

Thank you, Mr. Chairman.

Secretary CAMBONE. You are right. Some way has got to be found to do this.

Senator TALENT. Yes, because we clearly have a defect in this. Command influence is a problem but I think everybody involved in this probably wishes they had just said, "The heck with command influence, we have to pick up the phone and call"——

Secretary CAMBONE. Yes, sir.

Senator TALENT.—"and let people know."

Secretary CAMBONE. Yes, sir. Indeed, at least to the extent that the sergeant delivered the disk to the criminal investigative division (CID), he put in train, at least, a process that has brought all this to light.

Senator TALENT. Thank you, Mr. Chairman.

Chairman WARNER. Thank you very much.

Senator Dayton? I'm sorry, we have a different sheet, but I think Senator Nelson is preceding. All right, thank you very much.

Senator BEN NELSON. I hate to cheat my colleague from Minnesota out of his place, but——

Chairman WARNER. You've been getting here earlier and earlier each time. [Laughter.]

Senator BEN NELSON. I thank you, Mr. Chairman.

I thank the witnesses today, as well, for your very strong statements about your opinions, as well as the nature of the investigations. I'm going to ignore some of the partisan sniping that's been going on from the other side today, because I don't think it's particularly helpful.

Having said that, General Taguba, in your opinion this is not a top-down problem. I think what you're saying is that this was something that may have been spontaneous, but an abuse involving only a handful—last week, the operative word was "few" indi-

viduals, but I think that right now I think that perhaps it's a limited number of people. Is that accurate?

General TAGUBA. Yes, sir. Based on the interviews and the statements that were given to us by both the detainees, MP personnel, and those that we examined, there were others, but we just could not track them down.

Senator BEN NELSON. Who is the highest-ranking officer you interrogated?

General TAGUBA. My interviews, sir, Brigadier General Janice Karpinski.

Senator BEN NELSON. You didn't talk to General Sanchez?

General TAGUBA. No, sir.

Senator BEN NELSON. Did you talk to Colonel Pappas?

General TAGUBA. Yes, sir, I did.

Senator BEN NELSON. Who's the highest-ranking official—not officer—you may have talked to?

General TAGUBA. Sir, none. I stopped at General Karpinski.

Senator BEN NELSON. So what may have happened above General Karpinski is an open book. In other words, it's not—or it's a closed book. No one knows what may or may not have occurred above that level. Is that accurate? Insofar as your investigation is concerned.

General TAGUBA. Yes, sir. She did intimate to me other officials from the CPA that she interacted with, in terms of the prison system, the Iraqi prison system, but I did not go after that. I did do a midcourse brief to General Sanchez and General McKiernan, but only in that we were proceeding on the timeline without any great delay.

Senator BEN NELSON. But General Karpinski says that her command was severed by the infusion of MI dealing with certain detainees. Is that accurate or an approximation of her statement?

General TAGUBA. Sir, I don't understand where her command authority—her command was severed from Abu Ghraib?

Senator BEN NELSON. Because others were put in, and she was given the instruction—Colonel Pappas appeared on the scene, and MI not under her command were there, as well. Is that accurate?

General TAGUBA. Sir, it's contained in my report that when I asked her if she had known about FRAGO 1108 dated 19 November, the first time—the only time I interviewed her—she had no knowledge of that until about 2 days afterwards, of which I asked her what did she do after that, and then she wanted clarification from her chain of command, when she was told that the FRAGO was, indeed, in effect, and that the MI brigade commander was the commander, the forward-operating base commander.

Senator BEN NELSON. Under those circumstances, if her command wasn't severed, was it at least interfered with, in your judgment?

General TAGUBA. Sir, truthfully, she challenged that.

Senator BEN NELSON. In what way?

General TAGUBA. She challenged the authority that was given to Colonel Pappas.

Senator BEN NELSON. What was the result of the challenge?

General TAGUBA. Sir, it created confusion and friction between those two commanders.

Senator BEN NELSON. So what we have now is confusion, a lack of clarity of command. We have a handful, at least, of spontaneous abusers, as it relates to detainees. Do we know whether, in that prison or in other prisons where there were criminal prisoners, as well, not detainees, whether there was any abuse that carried over into their lives?

General TAGUBA. Sir, the FRAGO only affected Abu Ghraib. Camp Bucca was still under the 800th MP brigade, exclusively. So was Camp Cropper and Camp Ashraf.

Senator BEN NELSON. Were the abuses there anywhere similar? Were there photographs there, as in the case of Abu Ghraib?

General TAGUBA. None that we gathered, in terms of evidence, no, sir.

Senator BEN NELSON. Those other prisons were under her command. Is that correct?

General TAGUBA. Yes, sir. There were—you might consider abuse, but that was in terms of slapping a prisoner, and there were—

Senator BEN NELSON. Not similar type abuses as we have here.

General TAGUBA. Not to the gravity that was exposed, no, sir.

Senator BEN NELSON. And not photographs.

General TAGUBA. Not photographs, no, sir.

Chairman WARNER. Thank you very much, Senator.

Senator BEN NELSON. Thank you, Mr. Chairman.

Chairman WARNER. Senator Chambliss?

Senator CHAMBLISS. Thank you, Mr. Chairman.

General Taguba, it's refreshing to those of us who deal with the military every day, not only to look at your report, but to see your frankness here today. I think every military officer can certainly walk a little taller and a little straighter because of the work that all of you gentlemen are doing, but particularly, General, with respect to the way you have handled yourself and being willing to be critical where you need to be critical.

Now, General Smith, you made the statement earlier that this particular unit, the 800th MP brigade, was—they were trained—their job was this sort of stuff. Now, I'm assuming you mean from that that their job was to go over there and run this prison.

General SMITH. Sir—and maybe General Taguba can jump in on this a little bit—but I believe there are only one or two organizations of its type in the United States Army, and it is an internment and resettlement brigade.

Senator CHAMBLISS. Okay.

General SMITH. Is that correct, General?

General TAGUBA. That's correct, sir.

Senator CHAMBLISS. General Taguba, while General Schoomaker took exception to a comment I made the other day relative to the lack of training of this unit that just happened to be a Reserve unit, the fact of the matter is, there were a few dysfunctional individuals within this unit that, according to your report, was a very poorly trained unit that didn't have knowledge of what they were supposed to do. In fact, as I read your statement here, there's a general lack of knowledge, implementation, and emphasis of basic legal, regulatory, doctrinal, and command requirements within the

800th MP brigade and its subordinate units. Do you still stand by that statement?

General TAGUBA. Yes, sir, I stand by that statement.

Senator CHAMBLISS. In fact, your report is replete with comments relative to the lack of training of this particular unit that was supposed to be highly specialized and trained to do exactly what they were sent there to do, isn't that correct?

General TAGUBA. Sir, when I interviewed the company commander and asked them to outline for me what training he received at the mobility station, he basically gave me the typical basic requirements to only marksmanship, things of that nature. When I asked him, "Did you get any additional training prior to your deployment and into deployment with regard to internment and resettlement or anything that has anything to do with detention operations," he said he did not.

I did not interview the battalion commander, the 320th MP battalion commander, because he invoked his rights; however, those that we interviewed within that chain of command also concluded that.

Senator CHAMBLISS. Okay.

General, there's something that has puzzled me throughout this process that's evolved over the last—or been made public over the last 10 days or so. One thing is the fact that Major General Ryder went in there in October and November 2003 and did a report. In his report, according to your report, his objective was to observe detention and prison operations, identify potential systemic and human rights issues, and provide near-term, mid-term, and long-term recommendations to improve operations in the Iraqi prison system. Yet during the time that he was there, in Abu Ghraib, some of these incidents were occurring. I think your report confirms that. Certainly when he testified the other day before the Intelligence Committee, that was obvious. I have asked the question, privately and publicly, why didn't somebody come forward and tell Major General Ryder about this during the time that he was there when these incidents were going on? Do you have any—can you shed any light on that particular question?

General TAGUBA. Sir, I read General Ryder's report. I did not discuss it with him. I know that within the content of his report he visited quite a bit of the detention centers, not just exclusively Abu Ghraib. The results, of course, were his recommendations, I agreed with, in terms of putting things under single command and control, things of that nature. I don't want to speculate about anything with regards to any knowledge of detainee abuse having not been reported or being reported up the chain of command. It was apparent in our investigation that these things were happening, but we were puzzled also at the fact, sir, that none of this stuff was going above the battalion commander level. That's what we concluded, that none of this stuff was going above the battalion commander level.

Senator CHAMBLISS. Okay, thank you, General.

Chairman WARNER. Thank you very much, Senator.

The committee will continue right through the first vote, and if there's a second, likewise, until every Senator has had their opportunity to ask questions.

Next week we have our bill on the floor, according to the current schedule, so, in all likelihood, we'll have to suspend this series of hearings until after the bill has been considered.

Senator BILL NELSON. Mr. Chairman, will we continue with a second round?

Chairman WARNER. No, Senator, because I think we would be infringing on the policy counsels for both parties.

Thank you very much.

Senator Dayton.

Senator DAYTON. Thank you, Mr. Chairman. I thank you for holding today's hearings, and for your resolve to face these atrocities. You're an honorable man, and would that everyone shared your resolve to find the truth rather than to deny it or deflect it.

Unfortunately, we in this committee were overshadowed yesterday by President Bush's words and actions, traveling to the Pentagon with the Vice President to tell the SECDEF, the country, and the world, "You're doing a superb job." The President looked at a dozen more pictures of abuse, and reportedly shook his head in disgust, but the apologies, regrets, and mea culpas are now history. It's back to business as usual.

If anyone missed those subtleties, the Vice President was even more direct over the weekend when he said, "People ought to get off of his case and let him do his job," referring to the SECDEF. In other words, we should stop meddling and interfering and let them go back to running the war.

This morning illustrates the difficulty in a hearing to get beyond the words to the realities. General Taguba's report and directness here today are notable exceptions. But it shows why the pictures made such a difference. They showed us the truth. Most of the words today have managed to obscure that truth. We're told there were papers and procedures, policies and protocols, there were directives given, conditions set, and everyone followed the Geneva Conventions, international law, United States principles, except for a few people, who did very bad things unbeknownst to anyone else, all of whom were doing what they were doing to save American lives. So let's dispense with this and get back to our good intentions, the great progress going unreported in 95 percent of Iraq, the upcoming handoff of democracy to whoever the recipients shall be.

That's why those pictures are so disruptive, because they defy that sanitizing. They can't be obscured by non-descriptions like, "the inappropriate behavior of a sexual nature," which were words used to describe the forced masturbation of one detainee or the rape of another. That's why Pentagon officials are reportedly preventing the additional pictures from being publicly released.

The White House communications director said that the President wants the Pentagon to, "use its best judgment about the release of the photos." Well, we've seen where that best judgment has gotten us so far, and I think it's deplorable that they intend, again, to try to suppress the truth and all the truth from the American people.

Chairman WARNER. Senator, having worked on that question with the DOD, at this point in time the decision as to public release is an ongoing review. To the best of my knowledge, as of late

last night, no final decision has been made by the DOD, the White House, or others.

Senator DAYTON. All right. Thank you, Mr. Chairman.

If you go elsewhere—and thank goodness for a free and vigilant press, because I don't think we would find most of this out any other way—but there is an ICRC report which describes excessive patterns of—patterns of excessive force used by U.S. soldiers in prisons, and not just the one subject to this investigation, but throughout the country. The ICRC wrote that ill treatment during capture was frequent, that it often included pushing people around, insulting, taking aim with rifles, punching, kicking, striking, which seem to go beyond—seem to reflect a usual *modus operandi*, and appear to go beyond the reasonable, legitimate, proportional use of force required to apprehend suspects or restrain persons resisting arrest or capture.

The published reports say that as many as 43,000 Iraqis were detained at various times, and that an estimated 90 percent of them were determined to have not had any involvement in the matters that are under—that were of concern to U.S. authorities, that only 600 were turned over for prosecution, that 8,000 remain in detention now for indefinite periods of time, although I gather that there are now steps being taken to release all but 2,000 of them.

My time is up, but I'm just going to complete here by just referring to one individual who said he was taken from a barbershop where he was getting a shave, and he was beaten with pipes, starting on his legs and back, and moving to his head. He was bleeding from his mouth and ears, he fainted. When he woke up, he was in a dog's cage at a local military base. He was left naked in the cage for several days, receiving only scant food and water, until soldiers hung him from a tree by his cuffed hands, "They told me they would bring my wife and hang her next to me." I don't take any pleasure in recounting these incidents, but I take umbrage that there are still those who want to deny that they occurred to any degree or those that want to ascribe other motives to those of us who are just trying to face up to them.

I want the United States to succeed in Iraq. I'm deeply concerned that what's occurred there is going to cause further violence that will come down on our troops, that will bear the brunt of this, and set back our ability to meet our objectives there. But I don't see how that's going to be served by trying to obscure or deny what's occurring there or what has occurred there and make sure—try to make sure it doesn't happen again there or anywhere else in the world.

Thank you, Mr. Chairman. My time's expired.

Chairman WARNER. I thank you, Senator.

Senator Cornyn.

Senator CORNYN. Thank you, Mr. Chairman.

General Taguba, Chairman Warner asked, I believe, earlier, the question, "What went wrong?" You answered, there was a failure of leadership from the brigade level on down—and down. In your investigation, did you find any evidence—any evidence whatsoever—that culpability extended beyond the brigade level?

General TAGUBA. No, sir, we did not. However, we did recommend, based on some evidence that we gathered of the complic-

ity of MI interrogators, and we recommended that a separate investigation be provided under Procedure 15 of 380–10.

Senator CORNYN. How many individuals do you believe were involved in this abuse at Abu Ghraib?

General TAGUBA. Sir, directly, there were those six or seven, I believe. I know that the ongoing investigation continues under Article 32. I don't know of any others. In terms of those soldiers' supervisors and leaders, I enumerated that on my report. I believe there was a total of 17 there that I identified.

Senator CORNYN. So there were seven—there was disciplinary action taken against the seven supervisors, and then there was the actual criminal charges that have now been brought, I guess, against another seven, is that correct?

General TAGUBA. Yes, sir. Those were the criminal investigations, but I'm not involved in that whole process, but my investigation was purely administrative, to gather facts and circumstances that were related to detainee abuse and the other things that I mentioned to you earlier, principally their leaders.

Senator CORNYN. I ask those questions because I'm concerned that there are those who are suggesting that somehow what you have said was exceptional misconduct on the part of these guards and their supervising—their superior officers was somehow the norm. Indeed, there was a question asked earlier, attempting to suggest that this was the implementation of policies and procedures that are in existence at Guantanamo Bay. There was a question asked about whether Guantanamo Bay was somehow the baseline, and that now that represented the norm, and this was the logical conclusion of those policies and procedures at Guantanamo Bay.

I have to tell you that, like other members of the committee, no doubt, I've traveled to Guantanamo Bay because of my interest in the detention of the individuals there who—of course, who plan, finance, and execute terrorist acts against Americans and other innocent civilians. I had an opportunity to meet General Geoffrey Miller, who was the commander of the Joint Task Force at Guantanamo. I was very impressed with the treatment, with the policies and procedures that allowed the humane interrogation of detainees there.

Let me just ask you, is there any—whether they're enemy combatants or unlawful combatants or common criminals, is there any policy that you're aware of in the United States military that allows for less than humane treatment of detainees?

General TAGUBA. No, sir. I did not find that anywhere.

Senator CORNYN. Of course, we are concerned about the atypical conduct on the part of these individuals who committed these crimes, and those who failed to see that they got the supervision and the leadership necessary in order to avoid these crimes. But I must add my voice to those of others that say, while we are absolutely committed to getting to the bottom of this—and your report gets us a long way there—and of making sure that the guilty are held accountable, we can't forget the context in which all of this is taking place, and that is in a larger context of many other military troops serving honorably in Iraq and Afghanistan and elsewhere,

and the need to get essential information from some of these detainees that could well protect America from the next 9/11.

So I want to commend you and the others for the wonderful service that you're performing, and thank you for helping us get to the bottom of this. I hope that we will ultimately be successful in doing so, holding those accountable who are responsible, and then making sure we focus on our greater and more important job of making sure that America's safe in this war on terror.

Thank you, Mr. Chairman.

Chairman WARNER. Thank you very much, Senator.

Senator CLINTON.

Senator CLINTON. Thank you, Mr. Chairman.

I want to join in thanking you, General Taguba, for your service and for this report.

I don't think anyone disagrees with the last comment by my colleague that our objective is to both prosecute this war on terrorism successfully and also to ensure the safety and security of our own people from future attacks. The question is whether behavior and conduct and decisions with respect to the treatment of these detainees undermine the potential success that we all agree is essential to our national security.

I am still confused, and my confusion is this. With respect to the actions that are described in your report, General Taguba, you also included a number of other problems at other detention facilities. But is it your best information that no detention facility that was in any way connected with the 800th MP brigade had the level of problems that you reported in this unit at Abu Ghraib?

General TAGUBA. Yes, ma'am. The scope, again, was within the context of those facilities that the 800th MP operated.

Senator CLINTON. The 800th MP brigade was under the command of General Karpinski. Is that correct?

General TAGUBA. Yes, ma'am.

Senator CLINTON. Now, if the problems were severe and located principally in this one unit, then I think it is appropriate to follow the chain of command up to the decision to send General Miller to that prison, where, as I understand the testimony thus far, he set up a specific joint interrogation unit. He did, however one wants to describe it, either coordinate or direct the MP's involvement in the conditioning of the detainees. Is that a correct statement, General?

General TAGUBA. Yes, ma'am.

Senator CLINTON. All right. So it seems to me that if, indeed, General Miller was sent from Guantanamo to Iraq for the purpose of acquiring more actionable intelligence from detainees, then it is fair to conclude that the actions that are at point here in your report are in some way to General Miller's arrival and his specific orders, however they were interpreted by those MPs and the MI that were involved. Therefore, I, for one, don't believe I yet have adequate information from Mr. Cambone in the DOD as to exactly what General Miller's orders were, what kind of reports came back up the chain of command as to how he carried out those orders, and the connection between his arrival in the fall of 2003 and the intensity of the abuses that occurred afterwards.

Now, we know that General Karpinski has been rightly singled out for appropriate concern about her behavior and her failure of command. But I just want to read to you a comment she made in an interview, which I find extraordinary. I quote, "But when I looked at those pictures, and when I continued to see those pictures, I don't think that there was anything that was improperly done, because this wasn't something that was a violation of a procedure. This was something they were instructed to do as a completely new procedure. I'm not sure that those MPs had ever been confronted with any instructions like this before."

General Taguba, can you explain for us the disparity between holding this brigade commander completely accountable, and the comments that I just read to you, in light of the fact that certainly the 205th Military Intelligence Brigade was given tactical control over that prison? Can you explain General Karpinski's comment?

General TAGUBA. Yes, ma'am. During the course of our investigation, there was clear evidence, based on my interview of General Karpinski and Colonel Pappas, that there was friction between those two commanders in the operation of Abu Ghraib. The dissension was who was in charge of—when, and at what time. They could not explain. So that's the context of the ambiguity of the order that was given to Colonel Pappas. It was clear that he was directed to be the forward operating base commander there for security detainees and force protection. However, General Karpinski challenged that, and she noted that in her recorded testimony. Point one.

I held her accountable and responsible, not exclusively and solely for the abuse cases there at Abu Ghraib, but the context of her leadership, the lack of leadership on her part overall, in terms of her training, the standards, supervisory omission, the command climate in her brigade. Those were all, in totality, why I held her accountable and responsible, ma'am.

Senator CLINTON. Just one last follow-up, General. Did Colonel Pappas report directly to General Miller?

General TAGUBA. That I did not know because General Miller was not there. He reported, I believe, to CJTF-7.

Senator CLINTON. General Smith, do you know who Colonel Pappas reported directly to?

General SMITH. Yes, ma'am. Through CJTF-7. Ma'am, General Miller had no command relationship in this at all. He came over to do an investigation and make some findings and recommendations on how to improve. Nobody reported to him. He had no relationship whatsoever, other than to report details.

Senator INHOFE [presiding]. Thank you, Senator Clinton.

Senator Graham.

Senator GRAHAM. Thank you, Senator.

I think they've left, but just a few minutes ago there were some foreign military officers who came to the hearing, and I would just want to say, for the record, that I'm very proud of the fact that our military command system, civilian and military, comes out in the open, is asked hard questions, and has to appear before the public.

You've documented, General Taguba, some failings. I think we're failing the country ourselves up here a bit. I think we're overly politicizing this. This should be what binds us, not what tears us

apart. I think Republicans and Democrats may have a different view of a lot of things, but it seems to me that investigating a prison abuse scandal, when you say you're the good guys, should pull you together, not tear you apart. I would just hope my colleagues can understand that when you say you're the good guys, you have to act as the good guys.

So, General Taguba, how long have you been in uniform?

General TAGUBA. Sir, this is my 32nd year.

Senator GRAHAM. Saddam Hussein is in our control. How would you feel if we sicced dogs on him tomorrow?

General TAGUBA. Sir, on Saddam Hussein?

Senator GRAHAM. Yes.

General TAGUBA. Sir, we still have to follow the tenets of international law.

Senator GRAHAM. As much as you and I dislike him, as mean a tyrant as he is, and you know he'd kill us all tomorrow, I am so proud of you. What are we fighting for, General Taguba, in Iraq? To be like Saddam Hussein? Is that what we're fighting for?

General TAGUBA. No, sir.

Senator GRAHAM. Our standard, General Smith, can never be to be like Saddam Hussein, can it be, sir?

General SMITH. No, sir.

Senator GRAHAM. How long have you been in the service?

General SMITH. Thirty-four years.

Senator GRAHAM. Is it okay with you if the ICRC comes and looks at our prisons?

General SMITH. Absolutely, sir, and they should.

Senator GRAHAM. Okay. God bless you both.

General Taguba, it comes down to this for me. You have one prison that was run differently than other prisons. The photo we see of the detainee on the stool, wired up, was that just six or seven people having a good time in a perverted way at that person's expense, or is there something deeper going on there, and do you know?

General TAGUBA. Sir, based on the evidence, it was six or seven people who created that type of a scenario or situation.

Senator GRAHAM. Okay. To the dog scenario, where you see the detainee with two dogs, was that a couple of guards with dogs in a perverted way having a good time, or was there something else going on?

General TAGUBA. No, sir. The dogs were invited in there according to written statements, and collaborated by interviews, by the two MP guards.

Senator GRAHAM. The way these people were stacked up in sexual positions and the sexual activity, was that just individual guards or was that part of something else going on?

General TAGUBA. Sir, those were individual acts, as based again on interviews and statements and collaborated by the detainees' statements.

Senator GRAHAM. Part of the defense that we're going to be hearing about in these court-martials is that the people that we're charging are going to say this system that we see photographic evidence of was at least encouraged, if not directed, by others. Do you think that's an accurate statement?

General TAGUBA. Sir, I would say that they were probably influenced by others—

Senator GRAHAM. Okay.

General TAGUBA. —but not necessarily directed specifically by others.

Senator GRAHAM. We're not going to have a seminar in military law today, but I have a different view of command influence than some people have suggested, in terms of what we can disclose and how it would affect court-martials. There is another level of accountability in the military beyond just participating in out-of-bounds behavior, Geneva Conventions or otherwise. Do you agree with me that the UCMJ prevents this conduct regardless of the Geneva Conventions?

General TAGUBA. Absolutely.

Senator GRAHAM. So, ladies and gentlemen, what we're here today is to show the world that our military is governed by the rule of law, just like all of us. Having been a JAG officer for over 20 years, a prosecutor, a defense attorney, and now a Reserve judge, I have great confidence that we will get to the bottom of this. Do you agree with that, General Smith?

General SMITH. Yes, sir, I do.

Senator GRAHAM. Now, dereliction of duty is a concept unique to military law. It probably should apply to us in politics. A lot of us would be in trouble, probably me included, if that were the case. But in the military, as a commander, it can be a criminal offense if you derelict your duty to maintain good order and discipline in a way that crosses the line. Is that correct?

General TAGUBA. Yes, sir.

Senator GRAHAM. You interviewed a general officer. In your report, you indicated that you thought that general officer misled you about how many times that person had been to the prison system. Is that correct?

General TAGUBA. Yes, sir. That was collaborated by her own aide.

Senator GRAHAM. I would suggest to you, General Taguba, that out of this investigation, not only should we focus on the privates and the sergeants and the specialists who did criminal activity, but we also should have a higher accountability, that if a general officer misrepresents what they did, in terms of command and control, that a letter of reprimand may not be the appropriate sanction. But I will leave that discussion for others.

Colonel Phillabaum?

General TAGUBA. Colonel Phillabaum, yes, sir.

Senator GRAHAM. Your description of his time there was classic dereliction of duty. You have recommended a letter of reprimand for him.

General TAGUBA. Relief from command, sir, and to be removed from a promotion list.

Senator GRAHAM. My point is that Secretary Rumsfeld should not be held accountable for the criminal activity of others. It would be unfair to any military commander, politician, or otherwise to have to take a fall when people break the law and take the law in their own hands. However, those of us in responsibility do have a burden to bear.

Senator INHOFE. Senator Graham, your time has expired.

Senator GRAHAM. Can I just end with this one thought, Mr. Chairman?

Senator INHOFE. Yes, sir.

Senator GRAHAM. Secretary Rumsfeld has to manage the whole war. I think it would be unfair for him to take a fall if this is just a limited activity of a few people or of a prison poorly run. At the end of the day, General Taguba, responsibility, command and otherwise, is very much part of the military law and culture, and I appreciate what you've done to expose the failings.

Thank you very much.

Senator INHOFE. Thank you, Senator Graham.

Senator Bayh.

Senator BAYH. Thank you, Mr. Chairman.

Thank you, gentlemen, for your presence here today.

Two quick questions for you, Mr. Cambone, then one observation that if any of you want to react to, I would appreciate it. I apologize for moving expeditiously, but there is a vote that is about to expire.

Mr. Cambone, I'd like to follow up on the questions of some others—I think Senator McCain started, and then it was touched upon a little bit later—with regard to Ambassador Bremer's warnings.

Secretary CAMBONE. Yes, sir.

Senator BAYH. The published reports indicate that he began raising these warnings in about August of last year. As I understand your testimony, these were sort of general in nature, about the overcrowding and the concern for transiting people through there and returning them to their civilian situation when they didn't need to be retained any longer.

The ICRC report came to his attention in February or March, and you seemed to imply that perhaps his warnings became more specific with regard to activities in the prison thereafter. Is that the case?

Secretary CAMBONE. With respect to the first part of your question, sir—or your statement—I believe that to be the case. That is to say, I was not in communications with Ambassador Bremer, nor know of any statements by him specific to these abuses.

Senator BAYH. So in these meetings with the SECDEF, you were never present?

Secretary CAMBONE. I did not know of those. I did know of his general concern, as you said, for the prison population.

Senator BAYH. What about following the ICRC report?

Secretary CAMBONE. With respect to the 2004 report, I can only tell you, again, what I know, and that is that there was a meeting in that time frame, of February, at which members of the—senior members of the CPA staff met with members of the ICRC, and this report was made available. From that, there were some communications from CPA to the State Department and elsewhere with respect to these concerns.

Senator BAYH. About these abuses.

Secretary CAMBONE. That's what I think I know. Sir, I did not see the ICRC report until I began working my way into this problem over the last 2 weeks.

Senator BAYH. My second question involves the dispute between you and the general about who had tactical control at the prison. As I understand it, he believes that the MI individuals did exert practical tactical control, and it's your opinion that they did not. As I understand your position, the intelligence authorities were given control over the facility, but not control over the individuals running the facility. What exactly does that mean? How do you have control over a facility, but not the people who are running it? What were they in charge of, the plumbing or the—

Secretary CAMBONE. No, sir. In the same way that you have a building supervisor who doesn't tell the tenants how to do their business. In other words, you do require someone who is senior in command to be able to be responsible for the facility—that is, for its security from outside activity, internal security, the care and feeding of folks, all of those administrative and logistics tasks that go with running a large facility. Then there are, within that facility, a number of operations and activities that take place, which are under the command of other individuals, and those individuals are responsible for the exercise of command over those activities.

Senator BAYH. That's a layman's opinion. General, I'd be interested in your opinion. It seems to me the attempt here to draw this line may have contributed to the confusion about who was in charge, which may have led to some of these troubles. General, is that a fair comment?

General TAGUBA. Yes, sir. We followed doctrine in the context of our investigation as a matter of our baselines. We used those as references. Doctrinally, TACON, as given to Colonel Pappas, was that his mission was for security detainees and force protection. Doctrinally, if you are TACON to him, he establishes priorities.

Secretary CAMBONE. That doesn't go, sir, though, to the heart of his being able to give what would have been—and, General, correct me—unlawful orders to the commander of that MP battalion.

General TAGUBA. Yes, sir.

General SMITH. Nor, sir, does it allow him to change their mission. In other words, they're trained to a specific task. It's the person with operational control that is allowed to change how they do business and the like. So as General Taguba said, he can change the priorities for these folks, but they still have to operate within the guidelines and the doctrine that they are trained to. So they are still cops doing cop business.

Senator BAYH. General?

General TAGUBA. Sir, there were established standards two, in fact—that were signed by Lieutenant General Sanchez that stipulated what you can and cannot do. Those were clear. However, the failing here was that some leaders just did not comply with it. They were posted for a purpose, sir, and there are certain standards that they have to follow.

Senator BAYH. Compounded by a number of other things, including lack of uniformity in training.

My last comment—and this gets to the dilemma; we face this repeatedly in the intelligence arena, Mr. Chairman—and that is the following. Timely and accurate intelligence information is essential to our protecting our troops, civilians, winning the war against this insurrection and the larger war against terrorism. At the same

time, preserving our honor and our moral integrity is also vitally important, in the longer term, to winning this struggle, because that, at the end of the day, is what differentiates us from those with whom we fight.

Now, it seems to me there are—you've laid our, all of you, in your testimony—we begin taking our instruction, but how do you draw the line? How do you draw the line between vigorous but acceptable interrogation versus morphing into abuse? We start with the Geneva Conventions, as general principles. I think, Mr. Cambone, you then used the term "approved interrogation techniques," of which there were 20 or 30, so we try and refine that general guidance into more specific guidance. Then exceptions are allowed at the behest or the direction of the commander, who, I assume, in this case, would have been General Sanchez, is that correct?

General SMITH. Yes, sir.

Senator BAYH. I assume he didn't authorize any exemptions.

General SMITH. No.

Senator BAYH. That's the process that we go through in trying to determine where the line is, what you can do and what you can't do.

I'd just like to conclude by saying, I think it is absolutely critical that we enforce the line as we defined it, vigorously, hold those who crossed it to account to show that we don't tolerate this kind of thing. But let's learn the lessons of the past, as well. We are currently trying to overcome some past intelligence abuses, 20, 30 years ago, and our reaction to those abuses that have hamstrung us in the covert arena, and otherwise. So let's draw the line, bright and clear. Let's institute training. Let's hold commanders who don't insist that the line be followed to account, as well as the foot soldiers. But let's not throw the baby out with the bath water, because gaining access to appropriate information is also important as we also preserve our moral integrity and our honor.

Secretary CAMBONE. Thank you for that, Senator. If I may say, in trying to answer the committee's questions today on these issues, if in any way I suggested that if we find that there was misconduct or misbehavior or inappropriate behavior on the part of anyone associated with the MI side of this, which General Fay is now looking at today, I can assure you and other members of this committee that we will be back here, and we will tell you that.

Senator BAYH. Thank you.

Senator INHOFE. Thank you, Senator Bayh.

Senator Lieberman.

Senator LIEBERMAN. Thank you, Mr. Chairman. Thanks to the witnesses.

In absentia, I wanted to thank Chairman Warner and Senator Levin for the speed and intensity with which they have convened this series of hearings, and I thank you gentlemen for being here.

We have a real challenge here, which is to deal with this inhumane, immoral, unacceptable, un-American behavior that happened in this prison, and maybe others—I want to ask some questions about that—and to do it as quickly as we can so that we can get back to fighting the war on terrorism, and to do it in so comprehensive and aggressive a way that we do not allow, or even fa-

ilitate unintentionally, the erosion of public support in this country for the critically important mission our troops are performing in Iraq and in the broader war against terrorism. That's why I appreciate these hearings. In that regard, I think the comprehensiveness of our investigation—yours, really—is critically important.

General TAGUBA, I just want to make clear, when you were asked to investigate, you were asked to investigate conditions at Abu Ghraib and two of the other most populated prison facilities in Iraq, is that correct?

General TAGUBA. Yes, sir. Matters related to training, standards, internal policies, and the like, yes, sir.

Senator LIEBERMAN. Are there other prison facilities in Iraq beyond those three, therefore, that have not been reviewed, or are they being reviewed now for conduct that we're concerned about?

General TAGUBA. Sir, I did not go beyond the four that I looked at during the course of the investigation, and I believe a subsequent investigation by the Army IG conducted that following my investigation. They looked at other facilities, also.

Senator LIEBERMAN. Is that General Ryder's investigation?

Secretary CAMBONE. No, sir, there's an independent investigation put in train by the acting Secretary of the Army that covers all—as I understand it—not only facilities in Iraq, but in Afghanistan, as well.

Senator LIEBERMAN. That was my next question. Afghanistan, as well.

General SMITH. That is ongoing, Senator.

Senator LIEBERMAN. That is ongoing?

General SMITH. Yes, sir.

Senator LIEBERMAN. In the sense that it predates this scandal?

General SMITH. No, sir. It continues today.

Senator LIEBERMAN. I gotcha. So that—would it be fair for you to say, through us, to the American people, that we are essentially looking everywhere throughout the American military prison system to make sure nothing like what happened at the Abu Ghraib prison is occurring anywhere else?

General SMITH. I would have to look at the specific charge that the Department of Army IG was given, but I believe that to be the case, certainly.

Secretary CAMBONE. With respect to the CENTCOM area of responsibility (AOR) and the handling of prisoners there, and terrorists who are in detention, the SECDEF has asked the Secretary of the Navy to take a look, as well, as Charleston and in other places where there may be internees.

Senator LIEBERMAN. Okay, that's very important. Let me come back. Obviously you will continue to report to us on the conclusions of those investigations.

I had an exchange with Secretary Rumsfeld on Friday that reverberated in my own mind over the weekend. I think one of the other Senators may have asked one of you a question about this. It is about the relevance of the Geneva Conventions to the prisoners being held in Iraq. I had read various statements by the SECDEF and others that confused me on this, because I don't think the Geneva Conventions were being applied precisely to detainees. In response to—in Iraq—my question on Friday, Secretary Rumsfeld

said the President announced from the outset that everyone in Iraq who was a military person and was detained is a prisoner of war; therefore, the Geneva Conventions apply.

Second, continuing with the Secretary's statement, the decision was made that civilians or criminal elements that are detainees are also treated subject to the Geneva Conventions, although it is a different element of it.

At an earlier point in an interview he did on television, he—and this is, I think, what was asked—before he said that they're not entitled to the Geneva Conventions—oh, I'm sorry, here it is—"The decision was made that the Geneva Conventions did not precisely apply, but every individual would be treated as though the Geneva Conventions did apply." So, first of all, my staff can't find the statement that the President made announcing that policy. Secretary Cambone, I would ask you—

Secretary CAMBONE. Sir, I'd be happy to get that for you, and I'm happy to ask the SECDEF this afternoon what, indeed, he had in mind in that expression. Senator Levin asked that question earlier, and I will ask him, and I will get you an answer.

Senator LIEBERMAN. I would appreciate that. As part of that, I would ask General Taguba or General Smith to respond to this part of it. How do we—there's a report in one of the papers today, based on an ICRC Report, that 70 to 90 percent of the detainees, according to the ICRC, were captured without solid evidence of their guilt, but—and the numbers are large—is there a process for determining—considering what Secretary Rumsfeld said on Friday—who is an EPW, and who is a detainee? Who's military, and, therefore, treated as a prisoner, or who's a detainee, and, therefore, who gets the higher level of rights, legally?

Secretary CAMBONE. We have at the moment very few, as I recall, EPWs left in the system. What we have, primarily, are those who have posed a threat to the security of the coalition forces, the Iraqi Government, the Iraqi people, or others who may have committed crimes of one kind or another against Iraqi citizens. There are some of those latter who are, as I understand it, in custody and being in the custody of Iraqi security police and things of that sort, and they are in a process to be brought forward before an Iraqi judicial process, which, itself, is slowly and painfully standing up.

Senator LIEBERMAN. Okay. So my final question—and I think my time is up, maybe I should ask you to bring it back to the Pentagon and then respond to it if you could—is the status, which is—because, as I read the Geneva Conventions, I think that detainees have rights under the convention. They're a lot lower than the rights of prisoners of war. So I'm confused by what seems to be the policy that Secretary Rumsfeld articulated on Friday, that though they're not entitled to the rights of Geneva Conventions, that we're giving it to them.

Secretary CAMBONE. Yes, sir. I will take one more step on behalf of my General Counsel, and I will offer you him—

Senator LIEBERMAN. Fine.

Secretary CAMBONE. —for a period of time, to come by and brief you and other Senators, as you might wish, Mr. Chairman, on precisely how this has unfolded, so that there is no confusion left in

the committee or in the American people about where we stand on the Geneva Conventions.

Senator LIEBERMAN. I appreciate that.

Thanks, Mr. Chairman.

Chairman WARNER [presiding]. Thank you, Senator.

I will be discussing, with the SECDEF and others, the other witnesses that I think should come before the committee, and I am considering the General Counsel, given his expertise in this area. So we'll do that.

Secretary CAMBONE. Yes, sir.

Chairman WARNER. I wish to thank the SECDEF, through you, Mr. Secretary, for the cooperation in putting together this series of hearings that we're holding today.

I would ask now, do you or any other witness have a response to a question or wish to make any added statement before we close out this morning's record?

Secretary CAMBONE. I do. Sir, I ordinarily begin my presentations here by saying that it's a pleasure. This is not. It is a duty and a responsibility. We take it seriously. General Dayton's point, we will get to the bottom of this.

Moreover, I would like to thank you for your courtesies. They are important to all of us who are grappling with a very difficult problem. In the end, we will answer this committee's questions and those of the other committees of Congress to the best of our knowledge, with as much knowledge as we have at the time we are asked the question. Sir, therefore, I say to you, if we read through this record and we find we have made a mistake, I have misspoken on the Geneva Conventions or I have told you something about command relationships that is incorrect, I would beg your indulgence to allow us to correct that record as quickly and as accurately as we can, and make any changes known to every member of the committee when we do so.

Chairman WARNER. I thank you for that offer, and it will be done.

Secretary CAMBONE. Thank you.

Chairman WARNER. This afternoon we'll be having Lieutenant General Keith B. Alexander—he's the Deputy Chief of Staff, G-2, United States Army, handling intelligence matters; Major General Ronald L. Burgess, Jr., Director for Intelligence, J-2, The Joint Staff; and Major General Thomas J. Romig, Judge Advocate General, United States Army.

If there are no other comments, I thank my colleagues for the sincerity, the tremendous time that each of them is putting in to prepare for this hearing. I think it has been a very successful hearing. I thank you, Secretary Cambone, General Smith, and General Taguba. The hearing is adjourned.

[Questions for the record with answers supplied follow:]

QUESTIONS SUBMITTED BY SENATOR JOHN MCCAIN

ABU GHRAIB CHAIN OF COMMAND

1. Senator MCCAIN. Secretary Cambone and General Smith, I would like to request a document that will lay out the entire chain of command, from the guards and interrogators in the prison all the way up to the SECDEF. I believe we need to see exactly how this chain of command operated, who it included, and who was ordering the personnel in Abu Ghraib to act in this way. Under whose authority did

the prison personnel operate and who issued instructions governing prison operations? Can you provide such a document to this committee?

Secretary CAMBONE. The military police operated under the command of the 372nd Military Police Company of the 800th Military Police Brigade. The interrogators were controlled by the Joint Interrogation Debriefing Center (JIDC) and the 205th Military Intelligence Brigade. Tab 1 contains the charts that reflect the chain of command, and has been previously provided to the Senate Armed Services Committee.

General SMITH. The premise of the question implies that abuse was ordered at some level. This is not established fact and certainly was not the policy of CJTF-7 or CENTCOM. Specific written policies were in effect and signed by Lieutenant General Sanchez that emphasized applicability of the Geneva—Hague Conventions and the importance of treating all protected persons in a humane manner.

The interrogator chain of command was as follows:

Interrogator—205th MI Bde—CJTF-7—CENTCOM—SECDEF.

The MP chain of command was as follows:

Guard—320th MP Battalion—800th MP Bde—[CJTF-7/CFLCC]¹—CENTCOM—SECDEF.

GITMO-IZING ABU GHRAIB

2. Senator MCCAIN. Secretary Cambone, General Smith, and General Taguba, it has been reported that General Miller wanted to GITMO-ize the confinement operations at Abu Ghraib prison because of your concern in that facility that MI was not getting the information from detainees like he thought they should be. What did he mean by GITMO-izing Abu Ghraib prison?

Secretary CAMBONE. I am unaware of any such statement being made by MG Miller.

General SMITH. CENTCOM is not in a position to speculate about what Major General Miller might have meant by the phrase “GITMO-ize Abu Ghraib” attributed to him in Senator McCain’s question. Major General Miller was not assigned to CENTCOM during the period in which he is alleged to have made that remark nor was he conducting his review at CENTCOM’s request. Also, his perception of the facility may have changed since his recent assignment to our AOR. Recommend directing this question to General Miller who is in a better position to respond as to his intention.

General TAGUBA. I have never been to Guantanamo so I would not know specifically what Major General Miller meant by the term “GITMO-izing” Abu Ghraib Prison. This question should be directed to Major General Miller.

GUANTANAMO BAY

3. Senator MCCAIN. Secretary Cambone and General Smith, are you comfortable with the open-ended detentions at Guantanamo Bay, Cuba?

Secretary CAMBONE. The United States has no interest in holding detainees at Guantanamo Bay any longer than is necessary. However, hostilities in the war on terrorism continue and we do not intend to take any action that would present an undue risk to our security interests. Within that framework, the U.S. Government has released and transferred out of detention at Guantanamo 140 detainees. Additionally, DOD has instituted an Administrative Review Board and procedures to determine annually if enemy combatants at Guantanamo Bay should be released, transferred, or continue to be retained. I expect this comprehensive review process to result in additional detainee transfers and releases.

General SMITH. To the extent these detainees represent a real threat to safety and security, their continued internment is necessary and essential for the protection of U.S. forces, our coalition allies, and the American people.

GENERAL OFFICER APPROVAL OF INTERROGATION TACTICS

4. Senator MCCAIN. Secretary Cambone, General Smith, and General Taguba, General Miller announced that certain practices would be discontinued, including hooding, stress positioning, and sleep deprivation, but that they would be permitted with approval by a general officer. Under what authority can a general officer permit these techniques?

¹ CJTF-7 had TACON of 800th MP Bde, CFLCC had OPCON of 800th MP Bde.

Secretary CAMBONE. This matter was reviewed extensively in the Kern/Fay investigation, on which the committee held hearings. Further, General Sanchez and General Abizaid testified before the committee and discussed their authorities in detail.

General SMITH. Practices not violative of international or national law or contrary to regulations issued by higher authority may be approved by a commander pursuant to the exercise of his command authority.

General TAGUBA. These practices were outlined in a CJTF-7 memorandum dated 12 October 2003, Subject: Interrogation and Counter Resistance Policy in which such practices would have to be approved by the Commander, 205th MI Brigade or by Lt. Gen. Ricardo Sanchez, CG CJTF-7. Commanders may approve practices which do not violate international or national law or which are not contrary to regulations issued by a higher authority.

CAUSE OF DEATH OF FORMER HEAD OF IRAQ'S AIR FORCE

5. Senator MCCAIN. Secretary Cambone, General Smith, and General Taguba, the Denver Post reports an allegation that the former head of the Iraqi Air Force died during interrogation when he was rolled up inside a sleeping bag so only his feet stuck out, and then sat on and rolled back and forth until he died of suffocation. Apparently the investigation concluded that this was a death from "natural causes." What can you tell me about this?

Secretary CAMBONE. The case concerns Major General Mowhosh, the former Iraqi Air Defense commander. General Mowhosh died on November 26, 2003, at Forward Operating Base Tiger, in western Iraq. The U.S. Army Criminal Investigation Command was notified of the death and initiated an investigation that same day. The Office of the Armed Forces Medical Examiner (OAFME) performed an autopsy on December 2, 2003, with preliminary indications that the manner of death was a homicide and the cause of death was asphyxia. OAFME issued a death certificate on May 12, 2004. I am advised that there is a criminal investigation into this incident.

General SMITH. At the 3d Armed Cavalry Regiment detention facility (FOB Tiger) in Iraq, an Iraqi detainee, Iraqi Army Major General A. Mowhosh, believed to be former Chief of Army Air Defense, died while in U.S. custody. On 26 November 2003, the detainee died while undergoing interrogation by MI soldiers. An autopsy was conducted which disclosed evidence of blunt force trauma to the body. The preliminary report, however, lists the cause of death as asphyxia due to smothering and chest compressions. The manner of death is listed as homicide. A criminal investigation is still ongoing.

General TAGUBA. I have no knowledge regarding the cause of death of this detainee.

EVIDENCE OF ABUSE IN OTHER U.S.-OPERATED DETENTION SITES

6. Senator MCCAIN. Secretary Cambone, General Smith, and General Taguba, have you seen any evidence of abuses at other detention centers in Iraq, at Guantanamo, in Afghanistan, or at any other detention center operated by the U.S. worldwide?

Secretary CAMBONE. As of late August, of the more than 50,000 individuals apprehended and detained since the beginning of hostilities, there have been about 300 cases of alleged detainee abuse across the Joint Operations Areas. 157 individual investigations have been completed and 66 cases were substantiated so far. Of those 66, 8 occurred in Guantanamo, 3 in Afghanistan, and 55 in Iraq. About one third of these cases occurred prior to, the detention facilities at the point of capture or tactical collection point, frequently under trying circumstances.

There has also been a series of 11 major, comprehensive investigations conducted prior to and since the situation at Abu Ghraib became known. Eight of these are complete and have been briefed to Congress or otherwise released. As the remaining three investigations develop their conclusions, we will share them with Congress as well.

General SMITH. No; I have not personally witnessed any evidence of abuse at a DOD-operated detention facility.

General TAGUBA. My investigation team visited only the four detention sites in Iraq—Abu Ghraib, Camp Cropper, Camp Ashraf, and Camp Bucca during the period of the 15–6 investigation. Other than Abu Ghraib, there were two reported detainee abuses cases at Camp Bucca. The 310th MP Battalion Commander at Camp Bucca took legal action on those cases.

PRISON GUARDS

7. Senator MCCAIN. Secretary Cambone, General Smith, and General Taguba, is it now, or has it been, administration policy that prison guards should “facilitate” detainee interrogations? If so, how were they instructed to do this?

Secretary CAMBONE. This matter has been investigated in several of the reviews the DOD initiated when the abuse allegations came to light. It is my understanding that the matter was addressed by those investigations during briefings to SASC members or staff and during hearings covering those investigations.

General SMITH. Prison guards are not to take an active role in detainee interrogations. A passive role such as observing and reporting is permissible.

General TAGUBA. The U.S. Army is the executive agent for EPW and Detainee Operations in accordance Army Regulation 190–8, and also Army Field Manual 3–19.40. There are no provisions outlined in these documents where prison guards should ‘facilitate’ detainee interrogations, nor do I know of any administration or command policy that directs it.

PERMISSIVE CLIMATE OF PRISONER ABUSE

8. Senator MCCAIN. Secretary Cambone, General Smith, and General Taguba, in Secretary Rumsfeld’s May 7, 2004 testimony, he testified that the Abu Ghraib prison personnel followed the provisions of the Geneva Conventions and that the Geneva Conventions were posted for all prison personnel to see. General Taguba has stated that neither the camp rules nor the provisions of the Geneva Conventions were posted in English or in the language of the detainees at any of the detention facilities in the 800th MP Brigade’s area of responsibility. Would this supervisory error not contribute to a permissive climate of prisoner abuse?

Secretary CAMBONE. Posting of camp rules and the applicable Geneva Conventions is required by the conventions and service regulations. Detention facilities have posted Geneva Conventions rules both in English and detainee languages. In addition, I understand that it is standard operating procedure within MNF–I that the rules regarding both detention and interrogation, including the principles of the Geneva Conventions, are routinely briefed at shift changes and guard mounts.

General SMITH. If the provisions of the Geneva Conventions were not posted at 800th MP Brigade Facilities, this would be in error. However, the failure to post does not excuse individual instances of prisoner abuse. All MPs should have received training in the Geneva Conventions and Law of War prior to receipt of their military occupational specialty designation.

General TAGUBA. In accordance with Army Regulation 190–8, the Geneva Conventions are required to be posted in English or in the language of the detainees and must be available to the detainees. Guards and interrogators must also have general knowledge regarding the requirements of the Geneva Conventions Relative to the Treatment of Prisoners of War and be trained on the provisions of the Geneva Conventions. It is possible that non-compliance with the requirement to post the Geneva Conventions and have them available for detainees and guards could be a contributing factor to a permissive climate of prisoner abuse.

INTERNATIONAL COMMITTEE OF THE RED CROSS REQUEST

9. Senator MCCAIN. Secretary Cambone, General Smith, and General Taguba, the ICRC has stated that it repeatedly asked U.S. authorities to take corrective action with respect to the treatment of prisoners in Iraq. Which U.S. authorities were asked and why did they refuse?

Secretary CAMBONE. The DOD’s internal reviews concluded that we needed to improve our handling of ICRC reports to ensure that the concerns raised by the ICRC are reviewed by the proper authorities in the chain of command. It should be noted that the ICRC did, however, report their own concerns to responsible commanders at various levels and how those concerns were addressed is under review in the ongoing investigations we initiated after those allegations came to light.

General SMITH. During the period in question, ICRC reports were normally handled at the CJTF–7 level. I will defer to those military officials to provide any relevant details responsive to your questions.

General TAGUBA. I do not know specifically the U.S. authorities to whom the ICRC repeatedly requested that corrective actions be taken with respect to the treatment of prisoners in Iraq.

NUMBERS OF DETAINEES

10. Senator MCCAIN. Secretary Cambone, General Smith, and General Taguba, how many persons do we currently have detained in Iraq, Afghanistan, and elsewhere as part of the wars there and the war on terror?

Secretary CAMBONE. Although the figures vary daily as persons are released and others are interned, as of 29 August there were 5,405 persons under the control of MNF-I in Iraq, 476 persons under the control of CFC-A in Afghanistan, and 586 persons in Guantanamo Bay.

General SMITH. Although the figures vary daily as persons are released and others are interned, as of 6 August 2004, there were 9,416 persons under the control of MNF-I in Iraq and 454 persons under the control of CFC-A in Afghanistan.

General TAGUBA. The investigation covered the period of June 2003 to January 2004. Since there were no specific or common detainee accounting system in theater utilized by the 800th MP Brigade, the estimates of detainees in U.S. custody were from 11,333 as of June 2003 to 11,699 as of December 2003 in the four detention camps I mentioned earlier. I do not know the detainee population in Afghanistan or elsewhere.

PROSECUTION OF CIVILIAN OPERATORS IN ABU GHRAIB

11. Senator MCCAIN. Secretary Cambone, General Smith, and General Taguba, interrogation specialists from private defense contractors were operating inside Abu Ghraib and may have taken part in these atrocities. Given the UCMJ has been amended by the Military and Extraterritorial Jurisdiction Act of 1999, do you intend to prosecute the contractors who allegedly abused prisoners and committed other atrocities under the UCMJ?

Secretary CAMBONE. The Department of Defense is taking a wide range of actions to address the abuses at Abu Ghraib, including criminal investigative action. Such investigations can result in charges being brought against military members under the UCMJ, and against DOD civilian personnel and DOD contractors under the Military Extraterritorial Jurisdiction Act of 2000 (P.L. 106-778) (MEJA). The MEJA extended Federal criminal jurisdiction to misconduct committed by persons employed by or accompanying the Armed Forces outside the United States. This includes civilian employees of both the Department of Defense and of contractors of the Department of Defense. Of course, authority to initiate prosecutions rests with the Department of Justice (DOJ), not the Department of Defense.

Additionally, the Fay investigation's review of the role of contractors at Abu Ghraib is now complete. The report includes recommendations to forward its findings to Army General Counsel and the DOJ for determination of appropriate action.

General SMITH. Culpable persons who abused prisoners will be referred to the relevant judicial authority system for appropriate action.

General TAGUBA. The U.S. Military does not have jurisdiction to prosecute civilians under the UCMJ except in time of war as officially declared by Congress. That is not the situation in Iraq. The criminal prosecution of U.S. civilians could only be effected by the host country or by the U.S. Department of Justice in coordination with a U.S. Attorney's office for violation of U.S. laws that have extra-territorial application.

 QUESTIONS SUBMITTED BY SENATOR SUSAN COLLINS

GRAVITY OF INITIAL ABU GHRAIB PRISON ABUSE

12. Senator COLLINS. General Taguba, did you see any indication that the initial reports of abuse at Abu Ghraib prison were not taken seriously by investigators or the DOD chain of command?

General TAGUBA. I believe the initial reports of detainee abuse were taken seriously by the CG, CJTF-7 and Commander, CENTCOM. Upon being made aware of these abuses, Lieutenant General Sanchez almost immediately requested that the CENTCOM commander appoint a two star general to investigate reports of detainee abuse and other matters relating to the 800th MP Brigade. The CENTCOM Commander, through his Chief of Staff, then directed the CFLCC Commander, Lt. Gen. David McKiernan to appoint such an investigating officer.

ABU GHRAIB CHAIN OF COMMAND

13. Senator COLLINS. General Smith, please describe the chain of command beginning with the alleged abusers. Who in that chain of command was aware of the initial reports of abuse of Iraqi prisoners?

General SMITH. The initial reports of abuse were reported to CID by a soldier stationed at Abu Ghraib. CID informed the suspects' commanding officer who in turn made notification through the operational chain of command. The Commander of CJTF-7, Lieutenant General Sanchez, promptly reported the matter to General Abizaid, who in turn quickly advised Chairman of the Joint Chiefs of Staff, General Myers. Other reporting may have occurred through both Service and CID channels. Those alleged to have committed the abuse are assigned to the 372nd MP Company, 320th MP Battalion, 800th MP Brigade. The brigade commander was under the tactical control of the Commander, CJTF-7 and the Operational Control of the Combined Forces Land Component Commander (CFLCC).

QUESTIONS SUBMITTED BY SENATOR CARL LEVIN

MILLER REPORT

14. Senator LEVIN. Secretary Cambone, in early September 2003, Major General Geoffrey Miller, Commander, Joint Task Force Guantanamo, led a team to review current ability to rapidly exploit internees in the Iraqi theater for actionable intelligence. It has been generally reported that General Miller's team recommended that military police in Iraq be used to set the conditions for the successful interrogation and exploitation of internees/detainees. Why was General Miller sent to Iraq, what were his specific orders, and who recommended that he be sent and why?

Secretary CAMBONE. MG Miller was dispatched to Iraq via joint staff message to advise CENTCOM and the Iraq Survey Group on detainee operations in Baghdad, including interrogations. Dr. Cambone was involved only to the extent that he was interested in having MG Miller help improve the flow of intelligence information to CJTF-7 and back to the subordinate commands. MG Miller had no directive authority in that visit. He was in Iraq from August 31 to September 9, 2003.

15. Senator LEVIN. Secretary Cambone, who in the Office of the SECDEF was briefed on General Miller's recommendations and who approved these recommendations?

Secretary CAMBONE. The USD(I) was never officially briefed on MG Miller's report and only received a copy of the report April 2004.

16. Senator LEVIN. Secretary Cambone, when and how were General Miller's recommendations conveyed to commanders at CJTF-7?

Secretary CAMBONE. Major General Miller conducted briefings to the staff on 3 and 7 September 2003 during the course of his visit and concluded with an exit briefing on 9 September 2003.

17. Senator LEVIN. Secretary Cambone, does the DOD agree with General Taguba's conclusion that MP should not be involved with setting "favorable conditions" for subsequent interviews?

Secretary CAMBONE. The Department agrees with the statement General Sanchez made before the SASC on 19 May: "MPs were involved in passive enabling of those operations and had no involvement in the conduct of interrogations. Those were the orders in the SOPs that remained after General Miller's visit."

18. Senator LEVIN. General Smith, according to the Washington Post, General Sanchez is reported to have issued a memorandum on October 12, 2003, calling for a "harmonization" of military policing and intelligence work at Abu Ghraib to "maximize the efficiency of the interrogation." Did General Sanchez issue this memorandum based on the recommendations of General Miller's report?

General SMITH. The 12 October memorandum was the CJTF-7 Command Interrogation and Counter-Resistance Policy. To the best of my knowledge, it was issued, in part, based upon Major General Miller's recommendations.

END STRENGTH AND TRAINING OF THE 800TH MP COMPANY

19. Senator LEVIN. General Smith, it appears all MP functions at Abu Ghraib were performed by Reserve MP units, at least during the period in question. The

Taguba Report noted that the units of the 800th MP Brigade are greatly under strength, as Reserve component units do not have individual personnel replacement system to mitigate medical losses or the departure of individual soldiers. Why was an inadequately staffed, inadequately trained, and unprepared unit sent to handle such a critical task? Who bears responsibility for this staffing decision?

General SMITH. This Reserve Brigade's purpose was to fulfill the mission for which it was assigned. Brigade leadership was expected to fulfill its mission by adapting and utilizing soldiers who were supposed to be trained to accomplish mission requirements. As the Taguba Report notes, there are only two MP (Internment/Resettlement) Battalions in the Army, which have corrections training on their Mission Essential Task List (METL). The Taguba Report also noted that the Commander of the 800th MP Brigade did a poor job of allocating resources. The Commander also did not train her soldiers in confinement operations after it became clear that the mission of her soldiers was to change after the fall of the former Iraqi regime. Adapting to the mission is expected of commanders, especially senior commanders. Some of the "staffing decisions" were dictated by the limitations in specific resources available; a situation which the U.S. Army has identified and is taking steps to correct.

20. Senator LEVIN. General Smith, is this a problem faced by Guard and Reserve units throughout Iraq?

General SMITH. Guard and Reserve units deployed throughout Iraq are expected to be trained and ready to perform their missions. Training and readiness are responsibilities of the Service components and are issues currently under review by those components.

21. Senator LEVIN. General Smith, have there been any changes in the training of the MP units and personnel since the detainee abuses were first discovered? If so, what changes have been made to date, and when were they made?

General SMITH. Training and readiness are the responsibilities of the Service components and I would defer to those officials to report on changes made.

TAGUBA REPORT RECOMMENDATIONS

22. Senator LEVIN. General Smith, General Taguba's report contained a number of recommendations with regard to the situation at Abu Ghraib detention facility. To what extent have the recommendations contained in the Taguba Report been adopted and implemented? Please address each of the specific recommendations in the three parts of the report.

General SMITH. The attached summary of MNF-I actions is responsive to this question.

**15-6 INVESTIGATION OF 800TH MP BDE
(Basic Taguba Report)**

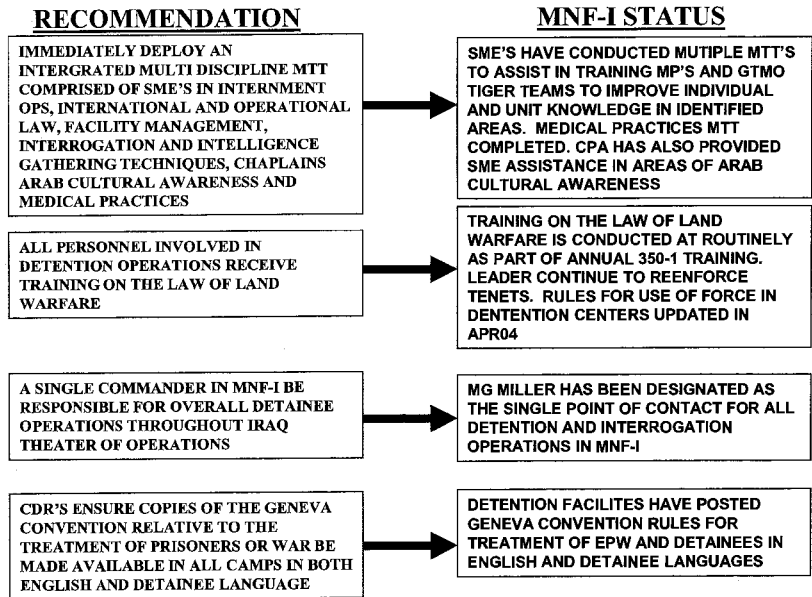

15-6 INVESTIGATION OF 800TH MP BDE 1

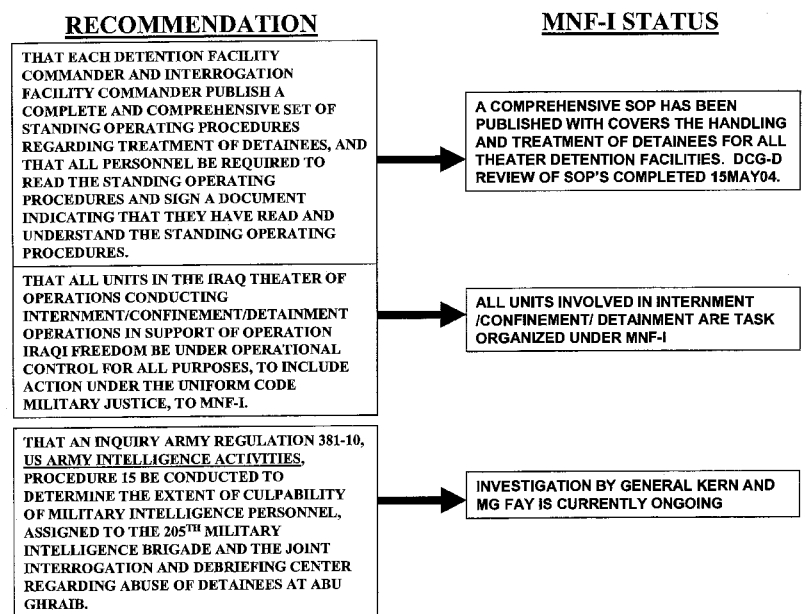

15-6 INVESTIGATION OF 800TH MP BDE 3

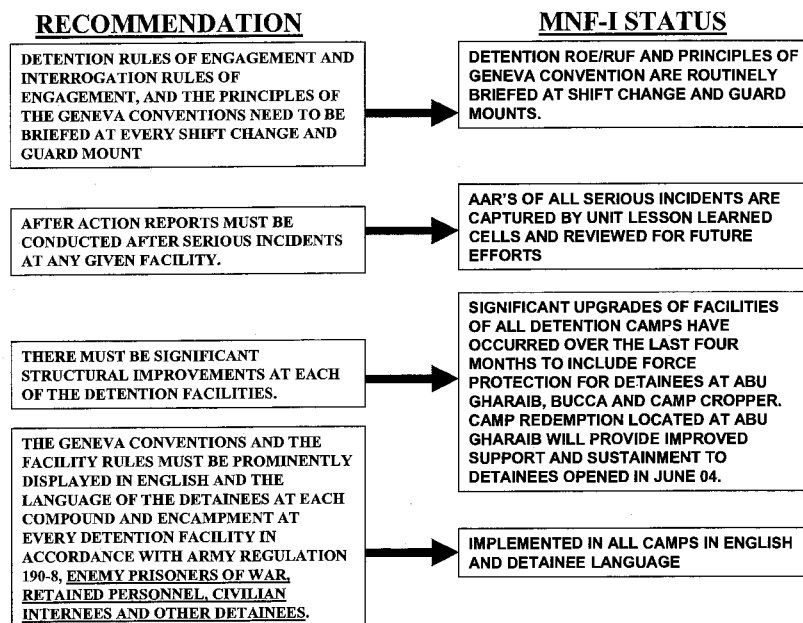

15-6 INVESTIGATION OF 800TH MP BDE 2

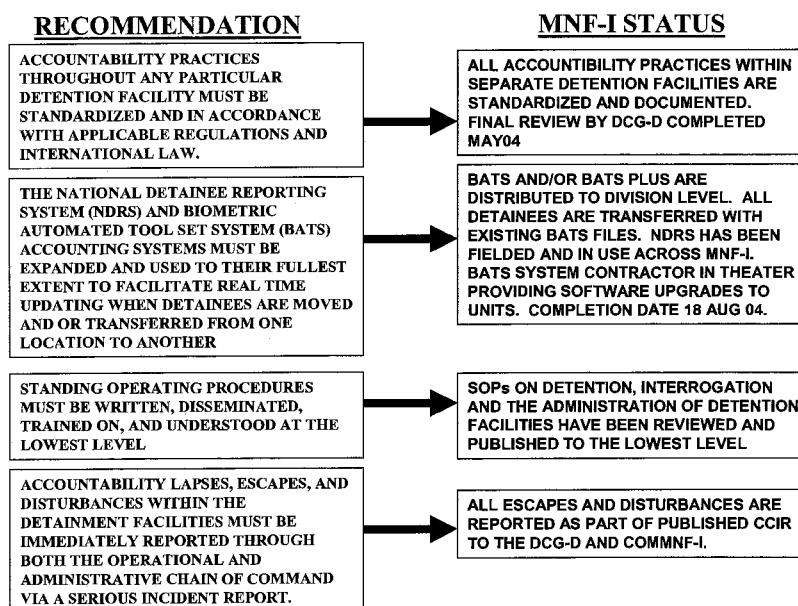

15-6 INVESTIGATION OF 800TH MP BDE 4

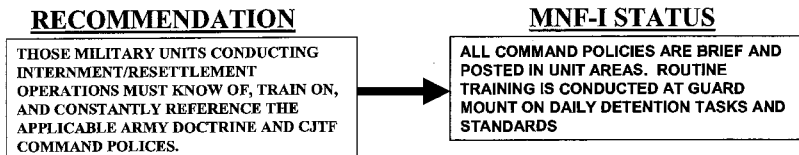

JTF-GTMO SME GROUP (Annex to Taguba Report)

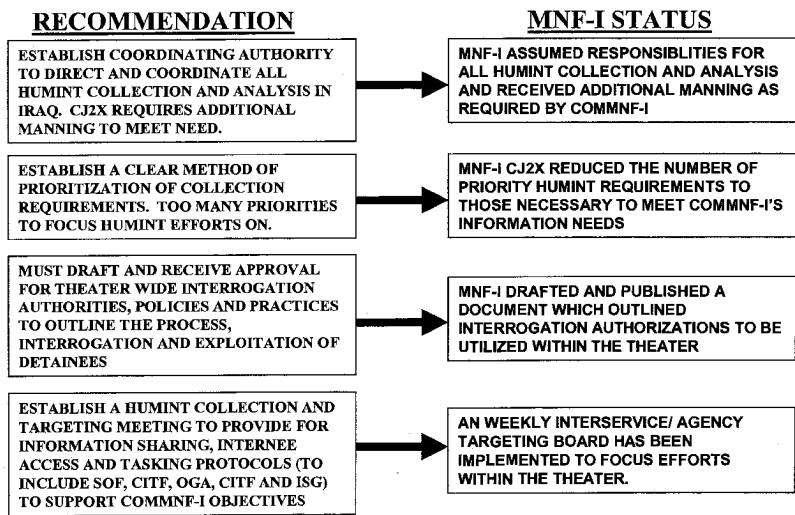

JTF-GTMO SME GROUP (Annex to Taguba Report)

<u>RECOMMENDATION</u>	<u>MNF-I STATUS</u>
EXPEDITE EXCHANGE OF CT INFORMATION BETWEEN COLLECTORS AND NATIONAL INTEL COMMUNITY THROUGH THE INTEGRATION WITH JTF-CT	JTF-CT REPRESENTATIVES NOW IN PLACE AT PRIMARY THEATER INTERROGATION FACILITIES
ESTABLISH AND TRAIN TIGER TEAMS COMPRISED OF INTERROGATOR AND ANALYST.	5 GITMO TEAMS ATTENDED TIGER TEAM UNIVERSITY AT FORT HUACHUCA PRIOR TO DEPLOYMENT. MNF-I HAS 20 TIGER TEAMS AT READINESS LEVELS 1 & 2. SIX TIGER TEAMS HAVE GRADUATED AND THREE MORE AVAILABLE SEVEN DAYS AFTER INITIAL TRAINING
CONSOLIDATE THE INTERROGATION MISSION AND ONE JIDC/ INTERROGATION FACILITY UNDER MNF-I COMMAND	DCG-DETAINEE OPS NOW THE SINGLE POINT FOR INTERROGATIONS. FINAL SYNCHRONIZATION COMPLETED 15MAY04
DEDICATE AND TRAIN A DETENTION GUARD FORCE SUBORDINATE TO THE JIDC COMMANDER THAT SETS THE CONDITIONS FOR SUCCESSFUL INTERROGATION AND EXPLOITATION	MP'S WERE NOT TASK ORGANIZED UNDER THE JIDC COMMANDER. MP'S ARE NOW TACON TO DCG-DETAINEE OPERATIONS FOR THE DETENTION AND PASSIVE INTERROGATION SUPPORT MISSIONS
TRAIN ANALYSTS TO INCORPORATE DATABASES INCLUDING DIMS, CT-LINK, WEB SAFE, HARMONY AND COLISEUM IN INTERROGATION PLANNING AND EXECUTION	INFORMATION MANAGEMENT SYSTEMS (IDC) TO FACILITATE ANALYST EFFORTS, TO INCLUDE IDC, ARE BEING UTILIZED. COLOCATION OF IDC TERMINALS AT ABU GHARAIB BY 01 SEP 04

JTF-GTMO SME GROUP (Annex to Taguba Report)

<u>RECOMMENDATION</u>	<u>MNF-I STATUS</u>
PROVIDE ONE BSCT TEAM TO SUPPORT INTERROGATION OPERATIONS	O-6 BEHAVIORAL PSYCHOLOGIST AND PSYCHIATRIST ARE ASSIGNED TO JIDC
ASSESS AND REFINE TRANSFER CRITERIA TO SUPPORT CONTINUED RAPID EXPLOITATION OF HIGH VALUE DETAINEES AND RELEASE OF LOW VALUE DETAINEES	TRANSFER CRITERIA FROM DIVISION TO THEATER LEVEL IS MAXIMUM 14 DAYS; THEATER SCREENING CRITERIA APPROVED. HAVE REVIEWED 5400+ DETAINEES SINCE APRIL 04
MNF-I PROVIDE CJSOTF TIGER TEAM SUPPORT	MNF-I HAS PROVIDED 5 TIGER TEAMS TO SUPPORT TF 121, TF 626 AS RECOMMENDED
DEDICATE A JAG TO ADVISE CDR'S AND INTERROGATION LEADERSHIP ON REQUIREMENTS TO OPERATE WITHIN APPROVED INTERROGATION AUTHORITIES	THE SJA HAS BEEN DESIGNATED AS LEGAL ADVISOR TO DCG-D; ADDITIONAL JAG OFFICERS SERVE AS CCCI ADVISORS FOR JUDICIAL EFFORTS
DEVELOP A COMPREHENSIVE SET OF DETENTION PHYSICAL SECURITY SOP'S. CONDUCT LEADER AND TROOPER TRAINING ON SOP'S	DETENTION FACILITIES HAVE PUBLISHED DETAILED SOP'S ON DETENTION OPERATIONS AND CONDUCT REGULAR TRAINING

JTF-GTMO SME GROUP (Annex to Taguba Report)

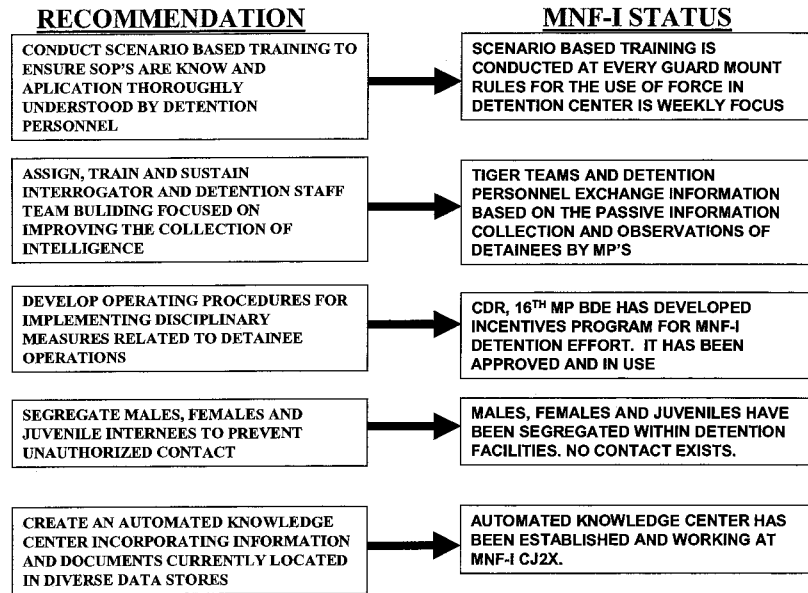

MG Ryder Report (Annex to Taguba Report)

<u>RECOMMENDATION</u>	<u>MNF-I STATUS</u>
ENCOURAGE JOINT CPA/MNF-I CENTRALIZED PLANNING WITH DECENTRALIZED EXECUTION; TAKE ADVANTAGE OF CURRENT MILITARY STRUCTURE TILL OIF 2.	PLANNING FOR INTERROGATION PRIORITIES IS CENTRALIZED WITH CJ2X AND ISG WITH INTERROGATION FACILITIES EXECUTING INTERROGATIONS
CONSOLIDATE SECURITY INTERNEES AT ABU GHRAIB (W/ SEPARATE HIGH VALUE DETAINEE SITE); CONSOLIDATE IRAQI PRISON OPERATIONS AT LARGE REGIONAL FACILITIES	HIGH VALUE DETAINEES AND CCCI CANDIDATES ARE CONSOLIDATED AT ABU GHARAIB FOR INTERROGATION AND DETENTION. DETAINEES OF LOW VALUE ARE BEING TRANSFERRED TO THE CAMP BUCCA
REMOVE ALL WEAPONS FROM THE INTERIOR AND PROXIMITY OF FACILITIES; APPLY GREATER DISCIPLINE TO KEY/TOOL ACCOUNTABILITY; CONDUCT USD/RULES OF ENGAGEMENT TRAINING	WEAPONS IN DETENTION FACILITIES ARE STRICTLY CONTROLLED. DETENTION PERSONNEL AND INTERROGATION PERSONNEL ARE PROHIBITED FROM MAINTAINING ANY ADDITIONAL WEAPONS WHEN WORKING WITH OR NEAR DETAINEES.
AUGMENT TRANSITION TO OIF 2 FORCES WITH ACTIVE COMPONENT 95C/31E NCOS (MSG, 3 SFCs) AT ABU GHRAIB AND ONE SQUAD AT THE HIGH VALUE DETAINEE FACILITY	31E SME ARE ASSIGNED AS SUPERINTENDENTS AT ABU GHRAIB (2) and CAMP BUCCA (3). BDE'S ARE PRESENT AT ALL DETENTION FACILITIES TO CONDUCT QA AND REMEDIAL/REFRESHER TRAINING AS REQUIRED. DETENTION MTT COMPLETED 31E TRAINING AND CERTIFICATION WITH ALL DETENTION PERSONNEL 28 JUNE 04.

MG Ryder Report (Annex to Taguba Report)

<u>RECOMMENDATION</u>	<u>MNF-I STATUS</u>
ASSIGN TWO MILITARY POLICE (INTERNMENT/RESETTLEMENT) BATTALIONS TO A MILITARY POLICE COMBAT SUPPORT BRIGADE TO CONDUCT SECURITY INTERNEE MISSION AT ABU GHRAIB AND HIGH VALUE DETAINEE SITE; AUGMENT STAFF	IMPLEMENTED WITH ONE I/R BN AT ABU GHARAIB. ALL OTHERS ARE COMBAT SUPPORT MP BN'S. DETENTION MTT IS CERTIFYING ALL NON-31E'S, CORRECTIONS MP'S ON CRITICAL DETENTION TASKS
OPCON ONE MILITARY POLICE (INTERNMENT/RESETTLEMENT) BATTALIONS TO BCT SECURING MEK COMPOUND.	MP COMBAT SUPPORT BATTALION SECURING MEK COMPOUND. PERSONNEL RECEIVING 31E MTT TRAINING AND CERTIFICATION
AUGMENT DIVISION PROVOST MARSHALS WITH CORRECTIONS EXPERTS (MILITARY POLICE CPT, 2 95C NCOS).	DIVISIONS MAINTAIN DETENTION NCO'S IN PMO. SME PROVIDING OVERSIGHT TO DIVISION AND BRIGADE DETENTION FACILITIES
CONTINUE RENOVATION PROJECTS OF FACILITY LATRINES/SHOWERS; USE DETAINEE LABOR TO MAINTAIN SANITATION STANDARDS	PROJECTS TO IMPROVE THE LIVING CONDITION OF DETAINEES AND SOLDIERS OVER THE LAST FOUR MONTHS HAVE GREATLY IMPROVED THE STANDARD OF LIVING FOR ALL PERSONNEL; DETAINEES ARE USED TO MAINTAIN SANITATION OF DETAINEE HOLDING AREAS

MG Ryder Report (Annex to Taguba Report)

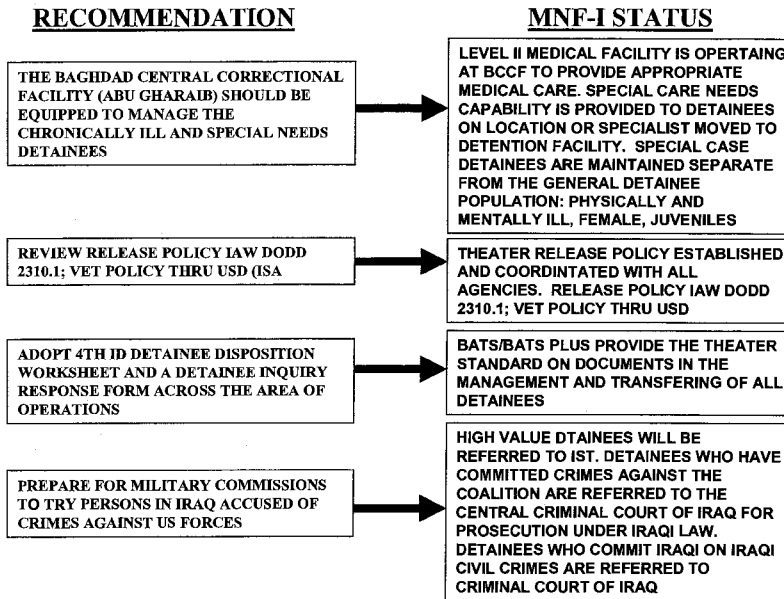

MG Ryder Report (Annex to Taguba Report)

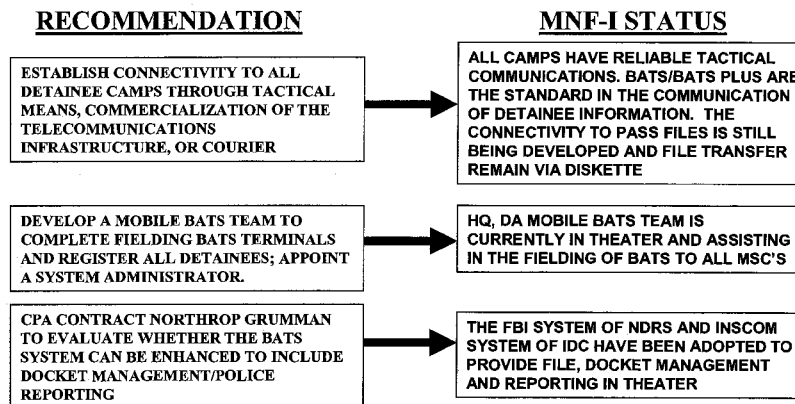

INTERNATIONAL COMMITTEE OF THE RED CROSS REPORT

23. Senator LEVIN. General Smith, the February 2004 report of the ICRC indicates that the abuses revealed in the Taguba Report were consistent with allega-

tions of abuse collected by the ICRC in the course of some 29 visits to 14 internment facilities in central and southern Iraq during the period of March to November 2003. The ICRC report makes clear that since the beginning of the conflict in Iraq, the ICRC regularly brought concerns about the ill-treatment of detainees to the attention of coalition forces. In addition, ICRC President Jacob Kellenberger has said that he met with senior administration officials in May 2003 and January 2004 to discuss issues related to the treatment of detainees at Guantanamo Bay, in Afghanistan, and elsewhere. How many times since the beginning of the conflict in Iraq were ICRC reports brought to the attention of coalition forces? Please provide any written reports provided by the ICRC to coalition forces concerning the treatment of detainees.

General SMITH. While ICRC reports are not classified documents, they must be handled as such. The information contained in these reports pertains to ongoing military operations and identifies facilities, practices, personnel, and detainees, including by name. This information is sensitive and requires protection. Staffers within DOD have worked closely with staffers of the congressional committees. The staff and members of the SASC have been briefed on this issue and DOD has made available all of the relevant ICRC reports to the committee members.

24. Senator LEVIN. General Smith, who in CENTCOM was aware of the ICRC's reports of prisoner abuse throughout 2003? What action was taken in response to these reports and why wasn't it more successful in addressing the underlying problems?

General SMITH. I was not personally aware of the ICRC reports of prisoner abuse throughout 2003. Based upon further inquiry, I have learned that only one ICRC report, dated 12 May 2003, was ever addressed to this command. This predated my assumption of duties by approximately 5 months. All other such reports have been addressed to subordinate organizations or officials at the Pentagon.

Our subordinate commands will hold accountable those who failed in their duties and they will ensure that the necessary training will be conducted to curtail future incidents. New leadership at the confinement facility is clearly aware of the need to heighten their vigilance to prevent any possible mistreatment of Iraqi detainees. Additional training on the Geneva Conventions has been conducted for the new units that are taking over detention operations to ensure the new soldiers are aware of their duties and responsibilities. Additionally, the reported allegations prompted Lieutenant General Sanchez to request the immediate provision of a team to conduct additional training on confinement operations, with emphasis on treating detainees with dignity and respect. A single senior officer with proper authorities and support to oversee all aspects of detainee operations has been appointed. Maj. Gen. Geoff Miller has been in place since 15 April 2004 and is properly focused and making a positive difference.

25. Senator LEVIN. General Smith, did CENTCOM keep senior administration officials informed of the ICRC's concerns about the ill-treatment of Iraqi prisoners? If so, at what level and on what occasions were they informed?

General SMITH. With one exception, ICRC reports and concerns were handled at the CJTF-7 level. CENTCOM did not receive ICRC reports. Had I known about the abuses as outlined in the ICRC reports which have now been furnished to this command, senior administration officials at the Pentagon would have been promptly informed. In fact, as soon as the abuses at Abu Ghraib were reported to CENTCOM, that information was immediately passed to the Joint Chiefs of Staff.

26. Senator LEVIN. Secretary Cambone, on how many occasions did senior DOD or administration officials meet with representatives of the ICRC and when did these meetings occur?

Secretary CAMBONE. There were four such occasions—May 27, June 27, October 15, and December 19.

27. Senator LEVIN. Secretary Cambone, were any investigations, changes in policy, or other actions initiated as a result of these meetings?

Secretary CAMBONE. The Department of Defense has already launched no less than 12 separate investigations into the ICRC's allegations of prisoner mistreatment:

- a. MG Ryder, the Army Provost Marshall General, launched an investigation to assess ongoing detention and corrections operations in Iraq. MG Ryder completed that assessment on November 6, 2003, and a copy of the Ryder Report has been provided to Congress.

b. MG Miller, Commander of the Guantanamo facility, launched an assessment of intelligence and detention operations that was completed on September 5, 2003. A copy of the Miller Report was provided to Congress..

c. MG Taguba's administrative investigation of detainee operations and the 800th MP Brigade was completed May 6, 2004, and a copy was submitted to Congress.

d. VADM Church completed a review of procedures at Guantanamo and Charleston on May 11, 2004.

e. LTG Jones and MG Fay are currently reviewing military intelligence and contractor interrogation procedures of the 205th MI Brigade at Abu Ghraib.

f. LTG Mikolashek, the Army Inspector General, is currently performing an overall assessment of doctrine and training related to detention operations.

g. BG Jacoby is currently reviewing detainee operations and facilities in Afghanistan.

h. Secretary Rumsfeld has ordered an investigation to collect authorized interrogation practices in the all DOD detention facilities used for the war on terror and to ensure that all appropriate policy guidance is being followed.

i. BG Formica is currently performing an administrative investigation into detainee abuse by CJSOTF-AP.

j. COL Ertman is performing an Army Reserve assessment of Reserve training with a focus on military intelligence and military police.

k. Hon. Schlesinger is leading an independent examination of detainee issues for the Department of Defense.

l. Finally, there are the criminal investigations of detainee abuse at Abu Ghraib and other detainee deaths while in Coalition custody.

m. To coordinate these various investigations and ensure a coherent policy response to their recommendations, the Department of Defense has created a new position, the Deputy Assistant Secretary of Defense for Detainee Affairs. This position will allow a single office to ensure compliance with DOD policy directives and coordinate with the ICRC. As part of this effort, DOD has taken steps to ensure that all ICRC reports (which formerly went only to officers in the field) are submitted directly to the Pentagon. The Departments of the Army and Navy are currently taking steps to launch criminal investigations into each instance of abuse alleged by the Red Cross.

28. Senator LEVIN. General Smith, the February 2004 ICRC report indicates that during a mid-October 2003 visit to the Abu Ghraib Correctional Facility, ICRC delegates witnessed "the practice of keeping [detainees] completely naked in totally empty concrete cells and in total darkness, allegedly for several consecutive days." In response to ICRC inquiries, the report states that "The military intelligence officer in charge of the interrogation explained that this practice was 'part of the process' for obtaining confessions and extracting information. In response to the allegations documented by the ICRC in mid-October 2003, or any other ICRC reports, what specific steps were taken to correct the situation at Abu Ghraib or any other detention facilities run by coalition forces and when were they taken?"

General SMITH. My expanded answer to question 24 responds to this question.

29. Senator LEVIN. General Smith, what was the extent of the ICRC's access to the facilities at Abu Ghraib and did it include the part of the facility where the abuses depicted in the photos are alleged to have occurred?

General SMITH. During the period in question, ICRC visits were coordinated by CJTF-7. I will defer to those military officials to provide any details responsive to your questions.

30. Senator LEVIN. General Smith, whom did the ICRC brief about these alleged abuses?

General SMITH. The ICRC exercised its prerogative to brief at the levels they thought were appropriate. The ICRC did not brief anyone in HQ, CENTCOM, to include me.

INTERROGATION TECHNIQUES

31. Senator LEVIN. Secretary Cambone, in an interview with The New York Times, Major General Geoffrey D. Miller, the new commander of American prisons in Iraq, stated that the roughly 50 techniques the military officially uses in prisoner interrogations include hooding, sleep deprivation, and forcing prisoners into “stress positions.” An unclassified December 12, 2003, Situation Update to Major General Miller is included as an annex to the Taguba Report. The document describes interrogation techniques permissible for use in the Iraqi theater of operations, and reportedly it includes a process allowing for the use of sleep management, sensory deprivation, isolation longer than 30 days, and dogs. Were you personally aware that permissible interrogation techniques in the Iraqi theater included sleep management, sensory deprivation, isolation longer than 30 days, and dogs?

Secretary CAMBONE. The USD(I) did not know what specific interrogation techniques were being used in the Iraqi theater. The techniques used in theater were developed and approved in theater without any USD(I) involvement.

32. Senator LEVIN. Secretary Cambone, who within the Army or DOD authorized the use of these additional techniques and were they specifically authorized for use in Abu Ghraib?

Secretary CAMBONE. Development of interrogation policies consistent with the standing guidance was within the authority of Combined Joint Task Force-7 and did not require higher-level approval.

33. Senator LEVIN. Secretary Cambone, what steps were taken to ensure that interrogation techniques complied with the Geneva Conventions?

Secretary CAMBONE. Prior to the commencement of Operation Iraqi Freedom, Commander, U.S. Central Command, prepared Operational Plan (OPLAN) 1003-V. Appendix 1 to Annex E of OPLAN 1003-V specifically addressed the treatment of the operational plan annex on enemy prisoners of war, retained persons, civilian internees, and other detainees. It outlined responsibilities, policies and procedures with respect to the handling of detainees, and provided specific guidance that the Geneva Conventions applied to all persons held by U.S. forces. This means of promulgation is consistent with the usual manner in which commanders provide guidance to their subordinate commanders. The subordinate commands would review the OPLAN and draft their own orders. For instance, the CJSC EXORD itself does not specifically address the Geneva Conventions; rather, it refers back to OPLAN 1003-V.

In addition to the promulgation of this OPLAN and its Annexes, commanders were responsible for ensuring that detainees were treated in accordance with the Geneva Conventions and applicable international law and that measures were implemented to ensure the forces were aware of and complied with the Law of War.

34. Senator LEVIN. Secretary Cambone, who within DOD made the legal determination as to whether these interrogation techniques comply with the Geneva Conventions, including the requirement of Article 31 of the Geneva Conventions that “No physical or moral coercion shall be exercised against protected persons, in particular to obtain information from them or from third parties” and to whom was that determination briefed?

Secretary CAMBONE. I understand that the CJTF-7 policy issued on October 12, 2003, titled “Interrogation and Counter Resistance Policy,” included interrogation approaches contained in existing interrogation doctrine (e.g., Army Field Manual 34-52), reflected longstanding DOD interrogation practice, and was issued after consultation with the CJTF-7 Staff Judge Advocate and lawyers within the U.S. Central Command.

35. Senator LEVIN. Secretary Cambone, what role did your office play in developing DOD policy on interrogation in Iraq?

Secretary CAMBONE. My office did not play any role in developing DOD policy on interrogation in Iraq.

36. Senator LEVIN. Secretary Cambone, did your office provide direction on interrogation guidelines to either General Abizaid or General Sanchez? If so, when and to whom?

Secretary CAMBONE. The USD(I) did not provide direction on interrogation guidelines to either General Abizaid or General Sanchez.

37. Senator LEVIN. Secretary Cambone, did you provide direction on guidelines to either Secretary Rumsfeld or Deputy Secretary Wolfowitz? If so, when and to whom?

Secretary CAMBONE. The USD(I) did not provide direction on interrogation guidelines to either Secretary Rumsfeld or Deputy Wolfowitz.

38. Senator LEVIN. Secretary Cambone, at a May 14, 2004, DOD press briefing, senior military officials stated that since last October General Sanchez had approved 25 requests to hold detainees in isolation for more than 30 days, but had not approved the use of any other interrogation technique requiring commanding general approval. General Sanchez also reportedly announced that he would deny requests to use other harsh methods that required his explicit approval. How many requests were made since the issuance of the Interrogation ROE for permission to use the interrogation techniques requiring General Sanchez's approval?

Secretary CAMBONE. The number of requests is unknown. However, the "Interrogation Rules of Engagement" were a graphic aid prepared by the 205th Military Intelligence Brigade. This aid is not a policy document and was not prepared or approved by Combined Joint Task Force-7. Lieutenant General Sanchez signed an "Interrogation and Counter-Resistance Policy" document on 14 September 2003. Revised policies were published on 12 October 2003 and 13 May 2004. Some of those policies required certain specific interrogation techniques to be approved in advance by Lieutenant General Sanchez on a case-by-case basis and after a legal review.

39. Senator LEVIN. Secretary Cambone, besides the 25 cases mentioned in the May 14 briefing, are there any other cases in which the use of these techniques was granted in the Iraqi theater?

Secretary CAMBONE. The only restricted technique that was approved for use was segregation in excess of 30 days. The figure "25" mentioned in the 14 May briefing was an estimate. Records at Multinational Force in Iraq Headquarters (successor to Combined Joint Task Force-7) indicate Lieutenant General Sanchez approved fewer than 20 segregations.

40. Senator LEVIN. Secretary Cambone, did General Sanchez suspend the use of these techniques as a matter of policy, or has a determination been made that they are not compliant with U.S. international obligations?

Secretary CAMBONE. Of the techniques that required his approval, only segregation in excess of 30 days was ever approved and used. Whether any of the other techniques could, as a hypothetical matter, have been approved under any specific set of circumstances is uncertain. However, both policy and law can be factors in reviewing the suitability of various interrogation techniques depending on the status of the detainee and the manner in which the technique might be employed.

41. Senator LEVIN. Secretary Cambone, in your testimony, you promised to provide a comparison of the command-level guidelines for the use in interrogation for detainees in Guantanamo and Iraq. Please provide this comparison.

Secretary CAMBONE. Attachment prepared by Detainee Task Force on 28 September 2004.

DTF Research
28 Sep 04Interrogation Techniques
FM 34-52/GTMO/IRAQ

Ref	Technique	FM 34-52 (1992)	4/16/2003 SECDEF APPROVED FOR SOUTHCOM (GTMO)	CJTF-7 10/12/2003 (IRAQ)
A	Direct	X	X	X
B	Incentive / Removal of Incentive	X	X	X
C	Emotional Love	X	X	X
D	Emotional Hate	X	X	X
E	Fear Up Harsh	X	X	X
F	Fear Up Mid	X	X	X
G	Reduced Fear	X	X	X
H	Pride and Ego Up	X	X	X
I	Pride and Ego Down	X	X	X
J	Futility	X	X	X
K	We Know All	X	X	X
L	Establish your Identity	X	X	X
M	Repetition Approach	X	X	X
N	File and Dossier	X	X	X
O	Mutt & Jeff		X	X
P	Rapid Fire	X	X	X
Q	Silence	X	X	X
	Change of Scene			
R	Change of Scenery Up		X	
S	Change of Scenery Down		X	
T	Diet Manipulation		X	
U	Environmental Manipulation		X	
V	Sleep Adjustment		X	
W	False Flag		X	
X	Isolation / Segregation		X	

SHADED AREA REFLECTS ARMY FIELD MANUAL 34-52 APPROVED TECHNIQUES

DTF Research
28 Sep 04Interrogation Techniques
FM 34-52/GTMO/IRAQ

Ref	Technique	FM 34-52 (1992)	4/16/2003 SECDEF APPROVED FOR SOUTHCOM (GTMO)	C/JTF-7 10/12/2003 (IRAQ)

SHADED AREA REFLECTS ARMY FIELD MANUAL 34-52 APPROVED TECHNIQUES

GENEVA CONVENTIONS

42. Senator LEVIN. Secretary Cambone, Secretary Rumsfeld testified on May 7, 2004, that the Geneva Conventions apply to all prisoners of war, retained personnel, civilian internees, and other detainees in the custody of U.S. forces in Iraq. General Taguba has stated that the Geneva Conventions were not posted at Abu Ghraib and military police at that facility were not trained in the applicability of the Geneva Conventions. When was the determination made that the Geneva Conventions did apply to all detainees in Iraq and by whom was it made?

Secretary CAMBONE. The Geneva Conventions applied during Operation Iraqi Freedom. The plans for Operation Iraqi Freedom that were prepared by Com-

mander, U.S. Central Command, and briefed to the President and me included provisions that clearly stated that enemy prisoners of war, retained persons, civilian internees, and other detainee “operations will be conducted in compliance with the 1949 Geneva Convention and applicable U.S. military regulations.” Further, component and supporting commanders were responsible under the plans for Operation Iraqi Freedom for “[e]nsuring that treatment of all detained persons is in accordance with the Geneva Conventions and other applicable international law.” The President directed these plans to be executed. Detention operations during Operation Iraqi Freedom were always to be conducted in accordance with the Geneva Conventions.

43. Senator LEVIN. Secretary Cambone, how was this decision disseminated to troops in the field and were specific directives or guidance sent out, of which the military police at Abu Ghraib should have been aware?

Secretary CAMBONE. (from 7 May Levin W, SECDEF, also used for #33): Prior to the commencement of Operation Iraqi Freedom, Commander, U.S. Central Command, prepared Operational Plan (OPLAN) 1003-V. Appendix 1 to Annex E of OPLAN 1003-V specifically addressed the treatment of the operational plan annex on enemy prisoners of war, retained persons, civilian internees, and other detainees. It outlined responsibilities, policies and procedures with respect to the handling of detainees, and provided specific guidance that the Geneva Conventions applied to all persons held by U.S. forces. This means of promulgation is consistent with the usual manner in which commanders provide guidance to their subordinate commanders. The subordinate commands would review the OPLAN and draft their own orders. For instance, the CJSC EXORD itself does not specifically address the Geneva Conventions; rather, it refers back to OPLAN 1003-V.

In addition to the promulgation of this OPLAN and its Annexes, commanders were responsible for ensuring that detainees were treated in accordance with the Geneva Conventions and applicable international law and that measures were implemented to ensure the forces were aware of and complied with the Law of War.

44. Senator LEVIN. Secretary Cambone, will the JAG be conducting his own review of the interrogation techniques listed in the October 12 Situation Update included in an annex to the Taguba Report to determine his assessment of their compliance with the Geneva Conventions?

Secretary CAMBONE. Department-wide, much has been done to improve detainee operations:

Army:

- Established Provost Marshal General in September 2003 as Army executive agent for detainee operations.
- Planning for general officer-level Military Police command in Army future force.
- Developed detainee operations integration plan—prioritized plan addressing policy, doctrine, organization, training, materiel, leadership, personnel, and facilities.
- Synchronized Army with joint policy and doctrine.
- Established Detainee Operations Oversight Council.

CENTCOM:

- Assigned a general officer to be in charge of all detention and interrogation operations in Iraq.
- Issued standard interrogation policies that emphasize application of Geneva Conventions and that are fully consistent with overall DOD policies.
- Upgrading detention facilities for soldiers and detainees.

Joint Staff:

- Created Joint Staff Detainee Affairs Division to address worldwide detainee operations.
- Drafted Multi-Service Tactics, Techniques & Procedures on Detainee Operations by the Air, Land, & Sea Applications Center.
- Expediting publication of Joint Doctrine for Detainee Operations (Joint Publication 3-63).
- Including Joint Interrogation Operations in “Joint and National Intelligence Support to Military Operations.” (Joint Publication 2-01)
- Added Detainee Operations to “Joint Training Policy and Guidance for the Armed Forces of the United States.” (Chairman, Joint Chiefs of Staff Instruction 3500.01C)

OSD:

- Established Deputy Assistant Secretary of Defense for Detainee Affairs (DASD-DA) office.
- Established a Joint Detainee Coordination Committee on Detainee Affairs chaired by DASD-DA.
- Issued policy “Procedures for Investigations into the Death of Detainees in the Custody of the Armed Forces of the U.S.”
- Issued policy “Handling of Reports from the International Committee of the Red Cross.”
- Initiated a department wide review of detainee-related policy directives.

As part of that department wide review of detainee-related policy directives, the Judge Advocate General will review all policies and directives in order to ensure their compliance with the Geneva Conventions.

[Whereupon, at 12:35 p.m., the committee adjourned.]

CONTINUE TO RECEIVE TESTIMONY ON ALLEGATIONS OF MISTREATMENT OF IRAQI PRISONERS

TUESDAY, MAY 11, 2004

U.S. SENATE,
COMMITTEE ON ARMED SERVICES,
Washington, DC.

The committee met, pursuant to notice, at 2:34 p.m. in room SD-106, Dirksen Senate Office Building, Senator John Warner (chairman) presiding.

Committee members present: Senators Warner, McCain, Inhofe, Roberts, Allard, Sessions, Collins, Talent, Chambliss, Graham, Levin, Kennedy, Byrd, Lieberman, Reed, Akaka, Bill Nelson, E. Benjamin Nelson, Dayton, Clinton, and Pryor.

Committee staff member present: Judith A. Ansley, staff director.

Majority staff members present: Charles W. Alsup, professional staff member; L. David Cherington, counsel; Elaine A. McCusker, professional staff member; Paula J. Philbin, professional staff member; Lynn F. Rusten, professional staff member; and Richard F. Walsh, counsel.

Minority staff members present: Richard D. DeBobes, Democratic staff director; Daniel J. Cox, Jr., professional staff member; Jeremy L. Hekhuis, professional staff member; Gerald J. Leeling, minority counsel; and William G.P. Monahan, minority counsel.

Staff assistants present: Michael N. Berger, Andrew W. Florell, Sara R. Mareno, and Bridget E. Ward.

Committee members' assistants present: Christopher J. Paul, assistant to Senator McCain; John A. Bonsell, assistant to Senator Inhofe; Darren M. Dick, assistant to Senator Roberts; Lance Landry, assistant to Senator Allard; Derek J. Maurer, assistant to Senator Collins; Clyde A. Taylor IV, assistant to Senator Chambliss; Meredith Moseley, assistant to Senator Graham; Mieke Y. Eoyang, assistant to Senator Kennedy; Erik Raven, assistant to Senator Byrd; Frederick M. Downey, assistant to Senator Lieberman; Elizabeth King, assistant to Senator Reed; Davelyn Noelani Kalipi, assistant to Senator Akaka; Eric Pierce, assistant to Senator Ben Nelson; Andrew Shapiro, assistant to Senator Clinton; and Terri Glaze and Randy Massanelli, assistants to Senator Pryor.

**OPENING STATEMENT OF SENATOR JOHN WARNER,
CHAIRMAN**

Chairman WARNER. Good afternoon. The Armed Services Committee reconvenes for a second panel to resume our hearing, a series of hearings regarding the mistreatment of Iraqi prisoners by some elements and certain personnel, few in number, I hope, of our Armed Forces, in violation of the United States Constitution and laws and international laws.

Testifying before us are Lieutenant General Keith B. Alexander, Deputy Chief of Staff, G-2, United States Army—General Alexander is the senior intelligence officer in the Army; Major General Ronald L. Burgess, Director for Intelligence, J-2, Joint Staff; and Major General Thomas J. Romig, Judge Advocate General (JAG) for the United States Army.

We're privileged to have you here. I thank you, Secretary Rumsfeld, and the Acting Secretary of the Army, Les Brownlee, for facilitating your presence here today.

Senator Levin, you can make any comments you want.

STATEMENT OF SENATOR CARL LEVIN

Senator LEVIN. Thank you, Mr. Chairman.

Let me add my welcome to our three witnesses this afternoon. We all appreciate their appearing before us.

This morning, General Taguba agreed with the conclusion of the International Committee of the Red Cross (ICRC), based on the evidence presented to him, that coercive practices, such as holding prisoners naked for an extended period of time, were a systematic part of the intelligence process at Abu Ghraib.

Additionally, we heard from Under Secretary Cambone that stressful and harsh approaches, including sleep deprivation and use of dogs, could be approved by the commander. But that doesn't square with the statements by the witnesses that the Geneva Conventions provisions and principles were supposed to be followed, since they don't allow for such practices. For instance, Article 31 of the fourth Geneva Conventions states that "no physical or moral coercion shall be exercised against protected persons, in particular to obtain information from them or from third parties." I hope that our witnesses this afternoon will address, in great detail, that issue.

Finally, Mr. Cambone said this morning that one of General Miller's recommendations for Iraq was to dedicate and train a detention guard force, subordinate to an intelligence commander, who would set the conditions for successful interrogation. But General Taguba told us this morning that under Army doctrine that should not be the function of a guard force. So that is also an issue which I hope our witnesses will address, along with a multitude of other matters which I know are before this committee.

Thank you, Mr. Chairman.

Chairman WARNER. Thank you, Senator Levin.

Gentlemen, will you kindly stand and raise your right hands? [Witnesses sworn.]

General Alexander and other witnesses, I presume each of you has a brief opening statement. Your entire statements will be admitted to the record.

If you will proceed, General Alexander.

STATEMENT OF LTG KEITH B. ALEXANDER, USA, DEPUTY CHIEF OF STAFF, G-2; ACCOMPANIED BY MG RONALD L. BURGESS, JR., USA, DEPUTY CHIEF OF STAFF, J-2; AND MG THOMAS J. ROMIG, USA, JUDGE ADVOCATE GENERAL

General ALEXANDER. Chairman Warner, Senator Levin, and members of the committee, on behalf of the men and women of the United States Army Intelligence, we appreciate the opportunity to appear before you today. With me today is Major General Ron Burgess, J-2, Joint Staff, and Major General Tom Romig, the JAG of the Army. I am making this statement on behalf of the three of us.

First, let me assure you that we find the alleged abuses of detainees in Abu Ghraib prison, Iraq, totally reprehensible. Army Intelligence neither condones, nor tolerates, these actions. Furthermore, we would like to emphasize that Army Intelligence soldiers are trained to abide by the highest standards for the humane treatment of all personnel in the custody of our soldiers worldwide.

We conduct extensive legal training for all of our Army Intelligence professionals, especially interrogators, in the law of war and the provisions of the Geneva Conventions of 1949. Our training manuals specifically prohibit the abuse of detainees, and we ensure all of our soldiers trained as interrogators receive this training.

Geneva Conventions protocols are reinforced during each practical exercise. Sir, there are 12 practical exercises that the interrogators go through, each of those last 2 hours. An interrogator will flunk an exercise should he or she inadvertently violate a Geneva Accord.

The contemptible behavior of a few soldiers does not represent the professionalism, dedication, and compassion demonstrated by the majority of soldiers in Iraq. Commanders and soldiers at every level have the duty to respect and follow the established international laws of armed conflict, and to treat everyone, to include those within our military detention facilities, with dignity and decency in the same ways that we expect to be treated, as Americans. Those soldiers who mistreated or humiliated detainees will be brought to justice swiftly. Again, the Army does not condone or tolerate such behavior.

The allegations of misconduct at Abu Ghraib have hit at the very core values of our Nation, the Department of Defense (DOD), and the Army, causing us grave concern, and prompting a very focused and thorough review of these incidents. Senior leaders at all levels take every report seriously, and expect an extensive investigation of every allegation.

The Combined Joint Task Force-7 (CJTF-7) in Iraq has an ongoing investigation of allegations that intelligence soldiers were involved in the abuse of detainees in Abu Ghraib. This investigation, called a Procedure 15, is currently ongoing and being conducted by Major General Fay for Lieutenant General Sanchez, and will identify and report questionable intelligence activities that may have violated law, executive order, or presidential directive.

Army Intelligence will not tolerate soldiers who violate the dignity and rights of others, to include those whom we have detained. We remain steadfastly committed to dealing expeditiously with any

complaint or allegation of mistreatment, and to ensuring our commanders take appropriate action.

Sir, I would like to address a few issues that arose during this morning's testimony.

First, on the interrogation rules of engagement (ROE), we brought with us the rules of engagement that were in effect at the CJTF-7 in Iraq prior to October 2003. These rules are in compliance with the Geneva Conventions, and directly stem from our interrogation manual, Field Manual (FM) 34-52. These are the rules that interrogation soldiers are trained on at Fort Huachuca. In addition, contractors were to read and sign that they understood these rules.

Second, in the timing of events, the ICRC reports cover periods from March 2003 through the end of 2003, and perhaps into 2004. They visited Abu Ghraib, we know for sure, in October 2003, on the 11th and 12th, and again on the 23rd, and conducted a series of interviews with detainees. That report, as Major General Taguba stated, was given to Brigadier General Karpinski to respond, and she provided her response on the 24th of December 2003. A formal report was produced in February 2004. Important to note is, many of the problems that were identified during that time period were prior to the issue of when the military intelligence (MI) brigade took over, on 19 November 2003.

Chairman WARNER. Did you personally get copies of those reports?

General ALEXANDER. Sir, I got copies of those reports this week. I did not get those last year. No, I did not.

Sir, reference tactical control (TACON), my understanding, in discussions with General Sanchez, was that the military police (MP) would remain in charge of detainee operations, but he needed Colonel Pappas to take over force protection and the overall management of the forward operating base (FOB) at Abu Ghraib and kick off many of the initiatives he wanted accomplished to upgrade the facility. However, this is a key issue, and I would recommend that we take this for the record, from the Joint Staff to Central Command (CENTCOM).

Sir, I would like to briefly go over interrogation operations, because I think this gets to the key that we see a split between MI and MPs. I think we need to understand that. In my discussions with General Ryder, we do not have a split. There is a door at places, and there is openness at places, and I'd like to explain that.

First, if you were to look at the general population for when prisoners of war (POW) come in there, that general population is seen most clearly by the MPs, and is screened by MI personnel who talk to the MPs on who are the key folks that are there. Sir, as you may expect, the MPs understand who are the ringleaders, who is the person who is in charge, and who are the key folks that may have intelligence value. It is a requirement in that phase that the MP and MI work closely together to develop and understand who are the high-value detainees.

The second step, isolating and getting those high-value detainees into the Joint Interrogation and Debriefing Center (JIDC), and looking at what goes on with those prisoners. The people who understand the environment that those prisoners are in day in and

day out, 24 hours a day, are the MPs, and the best way to understand that interrogation plan and the methods that the interrogator will use is the MP and the personnel who are around him, and that is one of the things that we need to have MP and MI talk about. Is this detainee or prisoner having a good day or bad? Has he been quiet, or has he been talking? What is the way to discuss this with him?

There is a gate, and that gates starts at the interrogation cell itself. That's where the MPs should not be involved, and that is the door that General Ryder talked about in my discussions with him. I think we need to be clear on that, because when we talk about doors we give the inference that we mean, "No MPs over here, and no MI over there."

That is what General Miller found when he went over there. He found that the MPs and the MI were not talking enough together, so that we missed key people who ought to have been interrogated, and that we weren't making the best value of it.

Now, there's another part of this that I need to walk through, and that is how we develop the interrogation plan. Because, sir, this is not something that we just say, "Okay, bring 'em in. What are we going to do?" We develop an interrogation plan. In that plan, we look at the prisoner. What do we want to get from this prisoner? What are the approaches, the techniques to be used? Sir, those techniques, again, are in our FM 34-52, and are in the ROE that I talked about. What are the questions to be asked? What do we learn?

That interrogation plan is to be approved by the chain of command. Then, from that, we get an interrogation report that comes out, the information that was received during that interrogation. The leaders review and approve both of those parts of that plan.

All of that stems from the priority intelligence requirements that the theater, the divisions, and the brigades have.

Sir, in early August, I went over to Iraq. One of the things that I found, in talking with the division commanders and the brigade commanders and CJTF-7, is that the flow of information that Dr. Cambone talked about, was not getting back to the units that apprehended these people. There was a problem. That flow of information—so if they grabbed a prisoner, the information on what that prisoner had that could have been useful for that brigade, the interrogation reports, were not getting there. That's important to saving soldiers' lives.

That was one of the key things that we were trying to fix. How do you get, when you consolidate all the prisoners from Iraq at one facility, information that goes back to 4th Infantry Division to this brigade to say, "This is the guy who fired the improvised explosive device, and he's part of this network." If it does not get there, we are not going to stop those attacks, and we're going to have soldiers killed. That was one of the things that we were looking at.

Chairman WARNER. Did you visit the prison and look at that?

General ALEXANDER. Sir, at the time I was there—I got there in early August—Abu Ghraib was not yet stood up. Abu Ghraib was in the phases of getting the prison stood up. The engineers were there, so it was not stood up. There were not prisoners at Abu Ghraib at that time. I have not been back to Iraq since August, sir.

Sir, once again, thank you for the opportunity to speak before you today, and we look forward to answering your questions.
[The prepared statement of General Alexander follows:]

PREPARED STATEMENT BY LTG KEITH B. ALEXANDER, USA

Chairman Warner, Senator Levin, and members of the committee, on behalf of the men and women of United States Army Intelligence, I appreciate the opportunity to appear before you today.

First, let me assure you that I find the alleged abuses of detainees in Abu Ghraib Prison, Iraq, totally reprehensible. Army Intelligence neither condones nor tolerates these actions. Furthermore, I would like to emphasize that Army Intelligence Soldiers are trained to abide by the highest standards for the humane treatment of all personnel in the custody of our soldiers worldwide.

We conduct extensive legal training for all of our Army Intelligence professionals, especially interrogators, in the Law of War and the provisions of the Geneva Conventions of 1949. Our training manuals specifically prohibit the abuse of detainees, and we ensure all of our soldiers trained as interrogators receive this training. Geneva Conventions protocols are reinforced during each practical exercise. An interrogator will flunk an exercise should he or she inadvertently violate a Geneva accord.

The contemptible behavior of a few soldiers does not represent the professionalism, dedication, and compassion demonstrated by the majority of soldiers in Iraq. Commanders and soldiers at every level have the duty to respect and follow the established international laws of armed conflict and to treat everyone, to include those within our military detention facilities with dignity and decency in the same ways that we expect to be treated as Americans. Those soldiers who mistreated or humiliated detainees will be brought to justice swiftly. Again, the Army does not condone or tolerate such behavior.

The allegations of misconduct at Abu Ghraib have hit at the very core values of our Nation, the Department of Defense and the Army Intelligence Community, causing us grave concern and prompting a very focused and thorough review of these incidents. Senior Leaders at all levels take every report seriously and expect an extensive investigation of every allegation. CJTF-7 has an ongoing investigation of allegations that Intelligence Soldiers were involved in the abuse of detainees in Abu Ghraib. This investigation, a "Procedure 15," currently ongoing and being conducted by Major General George Fay, will identify and report questionable intelligence activities that may have violated law, Executive Order, or presidential directive.

Army Intelligence will not tolerate soldiers who violate the dignity and rights of others, to include those we have detained. We remain steadfastly committed to dealing expeditiously with any complaint or allegation of mistreatment, and to ensuring our commanders take appropriate action.

Once again, thank you for this opportunity to speak before you today. I look forward to answering your questions.

Chairman WARNER. Thank you very much.

General BURGESS.

General BURGESS. Sir, I will stay with the statement as read by Lieutenant General Alexander, and I look forward to your questions.

Chairman WARNER. Fine.

General ROMIG.

General ROMIG. Sir, I have no comments, either. I look forward to your questions.

Chairman WARNER. Let us proceed with a 6-minute round, in hopes that we can get in two rounds this afternoon.

General Alexander, with due respect to you, you laid out very concisely and professionally, exactly what the manuals say, what everybody was supposed to do, but it didn't happen, and this committee—and you pointed out, General Fay is looking into that—is trying to put together a record for the Senate, for the American public, that lends some explanation to what happened.

Now, you're the chief of all Army Intelligence. Number one, the MI people that did the interrogations participated, presumably to

some degree, with the guards. They were your people down the chain, correct?

General ALEXANDER. Yes, sir.

Chairman WARNER. General Karpinski was in your chain, so to speak. Is that correct?

General ALEXANDER. She's in the Army, yes, sir.

Chairman WARNER. I realize that, but she was working with your people.

General ALEXANDER. Yes, sir.

Chairman WARNER. Now, what can you tell the committee, of your own knowledge, to help us and the American public and, indeed, much of the public in the world, to understand what went wrong? We know the wrongs occurred. We've gotten the initial reports—General Taguba. We, through the press, have seen pictures. It's a possibility the Senate may see additional pictures. The Pentagon is very forthcoming in trying to help this committee and the leadership of the committee and the leadership of the Senate develop that evidence. What can you personally tell, as chief, as to what went wrong?

General ALEXANDER. Sir, on the specifics, my assessment, it was a failure of leadership. What we need to—in terms of the MP leadership, as General Taguba said—the question, the real question is, did intelligence personnel tell those individuals to do that? Were those personnel low-level people who said this would be a good idea, or was that high-ranking personnel that said, "This is the method of operations?" My understanding and, to date, my belief, is that this was interaction between low-level people, who were not in the action of their duties, who were not doing interrogations at the time, or who made statements to these folks that, "Yes, what you're doing"—as it was in General Taguba's report—"is softening them up. They're speaking like crazy."

What General Fay has to find out in his investigation is, where was there complicity? Who and at what level did that go? To this point, my belief is that that was informal, and that these were a group of undisciplined MP soldiers who felt that they had some, according to their statements, preference from MI to go and do what they were doing. But we don't have any facts to an individual that did that, other than a couple of civilian contractors who were involved.

That's what we're looking for, sir. We will investigate that to find out exactly who said it and where does it go.

Chairman WARNER. So even though you're the chief of Army Intelligence, even though this series of problems has been going on since the fall of 2003, you cannot provide the committee any facts that help us understand exactly what was done and not done—by all levels, not just low levels—of those in the Intelligence Command. Is that correct?

General ALEXANDER. No, sir. I—

Chairman WARNER. All right.

General ALEXANDER. Let me go up higher. Clearly, at the higher levels, the rules of—

Chairman WARNER. A lot of people are following this. I think the committee understands "high" and "low."

General ALEXANDER. Yes, sir.

Chairman WARNER. What's your definition of "high," what's the definition of "low"?

General ALEXANDER. Let's start at the brigade level, where Colonel Pappas was involved. The two incidents that—

Chairman WARNER. He was an MI man, is that correct?

General ALEXANDER. He was an MI colonel, subordinate to the CJTF-7, working for General Sanchez. His responsibilities and his policies that he put out were—as an example, these interrogation ROE and the procedures. I know of two incidents—

Chairman WARNER. You know for a fact he did that?

General ALEXANDER. Yes, sir. We have—in fact, we also have his rules that he had folks coming in to brief them on. We had General Sanchez's statements of, "Here are the interrogator rules of engagement." Both of those are the same, and they stem from that same manual. In every case, it says, "Treat prisoners humanely."

Also, sir, I think it's important to note that when we talk about this humane treatment, when Colonel Pappas found a soldier having a prisoner walk naked, he found out about that and disciplined that soldier right away. So when actions were brought—

Chairman WARNER. What's the date/time group of that action?

General ALEXANDER. I don't have the date/time group, but I'll get you that, sir, for the record.

[The information referred to follows:]

On 16 November 2003, a military intelligence soldier decided to strip a detainee in response to what the soldier believed was uncooperative and physically recalcitrant behavior. Later the soldier walked the semi-naked detainee across the camp. Colonel Pappas left the issue to Lieutenant Colonel Jordan to handle. Lieutenant Colonel Jordan temporarily removed the soldier from interrogation duties. The soldier was counseled by her immediate supervisor but did not receive an Article 15, UCMJ.

General ALEXANDER. But he took action. So my thoughts are, when he knew something was going on, he took action. There were other cases of discipline that he took on soldiers who did an interrogation at the wrong time, and I will get you the exact date/time group of that, too. It's in General Taguba's report, but I think we need to get that, and I'll put that for the record.

[The information referred to follows:]

On 7 October 2003, three MI personnel conducted an interrogation without authorization. The three soldiers each received nonjudicial punishment, Field Grade Article 15s, from Colonel Pappas for failing to get authorization to interrogate the detainee. Additionally, Colonel Pappas removed them from interrogation operations.

General ALEXANDER. So it's clear, from where I sit, that both Colonel Pappas and the theater knew the ROE.

Chairman WARNER. But somehow that information either didn't flow down the chain or there was absolute total breakdown in discipline and disregard.

General ALEXANDER. That's what I believe.

Chairman WARNER. Go below Pappas. What's the next level?

General ALEXANDER. Sir, the next level was—

Chairman WARNER. Battalion commander, isn't it?

General ALEXANDER. There's the battalion commander, and there is the JIDC.

Chairman WARNER. All right. Can you tell us about their level of responsibility and inquiry into this situation?

General ALEXANDER. Right. Yes, sir. Lieutenant Colonel Jordan was the officer in charge of the JIDC. He is also mentioned in the Taguba Report for not doing his job. What we have to find out is, in executing his, and in executing Colonel Pappas's, what did they or did they not do. That's one of the things that General Fay has to find out, and that's part of that Procedure 15, sir. That's part of an ongoing investigation.

Chairman WARNER. I feel that, as hard as this committee tries to discharge its oversight, we're at the point where we're not likely to learn much about what took place and where that level struck a breakdown of discipline until this Fay Report is out. Is that your thinking?

General ALEXANDER. Yes sir, to get the accurate answer. I can give you an assessment, but that assessment will change as we find these facts out and as General Fay completes his investigation.

Chairman WARNER. Give us your assessment to date.

General ALEXANDER. Sir, my assessment is there was a complete breakdown in the discipline on the MP side, and there were some MI soldiers, contractors who may have been involved, or at least in some of those pictures. The question is, what did they say to the MPs to get them to do this? To this point, as General Taguba said, there is nothing that we know that a MI person told them to do this.

Chairman WARNER. All right.

General ALEXANDER. That's what we're trying to find out.

Chairman WARNER. Did the MI people hire the contractors?

General ALEXANDER. Sir, the contract actually stems under a CENTCOM contract, and that CENTCOM contract then went to CJTF-7. But the MI people there at Abu Ghraib were responsible for oversight of those contractors. It's important to note that what Major General Fast required of those contractors—and she's the C-2 in Iraq, the senior MI person in Iraq—

Chairman WARNER. I met her on my visit over there during the same time frame you were there.

General ALEXANDER. Right. Sir, they were to read and state they understood the interrogation ROE.

Chairman WARNER. Did she check their level of experience and training?

General ALEXANDER. Sir, that was part of the contract, that they were supposed to have the 97 Echo, which is our interrogation military occupational specialty (MOS), or equivalent, to be hired.

Chairman WARNER. All right. Do you have any knowledge of other government—U.S. Government agencies, Central Intelligence Agency (CIA) or otherwise, Defense Intelligence Agency (DIA) or any other group, that were working with your MI people?

General ALEXANDER. Sir, I know that there were other government agencies that visited the facility and talked to prisoners, but I know of no wrongdoing on their behalf.

Chairman WARNER. I'm not suggesting that. Who are they? What are they?

General ALEXANDER. The CIA.

Chairman WARNER. CIA.

General ALEXANDER. The CIA also conducted some interrogations, as I understand it, at that facility.

Chairman WARNER. What about DIA?

General ALEXANDER. Sir, I do not know that DIA conducted that. I would have to check that.

Chairman WARNER. All right. My time is expired.

Senator LEVIN.

Senator LEVIN. You say you have no evidence that MI people were actively involved in and directing, and suggesting that harsh activities occur?

General ALEXANDER. Sir, we have not found any.

Senator LEVIN. But—

General ALEXANDER. That's what we're looking for.

Senator LEVIN.—the Taguba Report itself quotes—for instance, on page 18, Sergeant Davis, the MP company Sergeant or Specialist Connell. He said, "I saw them nude, but MI"—military intelligence—"would tell us to take away their mattresses, sheets, and clothes." Isn't that evidence that MI—

General ALEXANDER. Sir, that—

Senator LEVIN.—told them to take away their clothes? Then you have Sergeant Davis stating that he heard MI insinuate to the guards to abuse the inmates. Isn't that evidence? When he asked what MI said, he stated, "Loosen this guy up for us. Make sure he has a bad night. Make sure he gets the treatment." Isn't that evidence that the intelligence folks were involved in this?

General ALEXANDER. Sir, those are the statements that spawned the Procedure 15 to look into exactly who said it. Because the statements, as you read those, it says, "MI personnel or people in civilian or people of authority." But when you ask, you get, "Well, who specifically told you to do this?" That's the question that we have to get to.

Senator LEVIN. But you've—

General ALEXANDER. They can't be—

Senator LEVIN.—some evidence, at least.

General ALEXANDER. Oh, absolutely. Sir, and that's why the investigation is going on.

Senator LEVIN. But I thought a minute ago you said you haven't seen any evidence that MI was involved.

General ALEXANDER. Sir, we have no proof that a person in authority told them to do this activity.

Senator LEVIN. Let's go back to the MI personnel. There is evidence, I take it, in the Taguba Report that MI personnel gave suggestions to the MPs that they "loosen this guy up," that they take his clothes away, that they make sure he has a "bad night," and that he gets "the treatment." That is evidence, isn't it, of MI personnel involvement?

General ALEXANDER. Yes, sir, that's a statement by those soldiers.

Senator LEVIN. Right. All I'm saying is, is that evidence? I'm not saying it's conclusive. I'm not saying anything other than it is evidence, is it not?

General ALEXANDER. Yes, sir. That's the evidence that led to the beginning of the Procedure 15.

Senator LEVIN. All right. So you've seen that evidence. Now, these interrogation ROE that I think you handed out—

General ALEXANDER. Yes, sir.

Senator LEVIN.—these are the ones that were adopted by whom?

General ALEXANDER. Sir, these were the interrogation ROE that were used by the 205th Military Intelligence Brigade and their interrogators.

Senator LEVIN. Who was in charge of that brigade?

General ALEXANDER. Sir, Colonel Pappas.

Senator LEVIN. Okay. Now, Colonel Pappas adopted these ROE, which talk about how long you can have sleep management, sensory deprivation, and stress positions. Are those all consistent, as far as you are concerned, and do you have a legal opinion saying those are consistent with the Geneva Conventions?

General ALEXANDER. Yes, sir. More importantly, because those are—and as it states in our manual, those are ones that we have to be very careful that we do not exceed the Geneva Conventions. It requires the commander's written approval to implement those.

Senator LEVIN. All right. You're saying that they are approved by the Geneva Conventions—

General ALEXANDER. Yes, sir.

Senator LEVIN.—that they're authorized by the Geneva—

General ALEXANDER. Yes, sir.

Senator LEVIN. But, second, you're saying that only with commander's approval. Do you have commander's approval for those activities in that prison?

General ALEXANDER. Sir, I am not aware of any situations that General Sanchez gave them written approval to do the ones that are under his part there.

Senator LEVIN. Do you have any situation where he was asked for written approval?

General ALEXANDER. No, none, sir.

Senator LEVIN. So there was no case where he was either requested, and, therefore, obviously, no case where he would have granted, written approval, although this specifically says that these activities require the commander's approval.

General ALEXANDER. That's correct. None that I know of, sir.

Senator LEVIN. All right. Thank you. Have you asked General Sanchez whether or not he had any requests?

General ALEXANDER. Sir, we have asked, and we have gotten—but I will ask formally, and I will—

Senator LEVIN. We've gotten—

General ALEXANDER.—I will respond—

Senator LEVIN.—what?

General ALEXANDER. Gotten the same response that I gave you—

Senator LEVIN. All right.

General ALEXANDER.—that none were there. But I will ask that formally and reply that back for the record.

[The information referred to follows:]

Lieutenant General Sanchez testified at the Senate Armed Services Committee hearing, 19 May 2004, with General Abizaid, Major General Miller, and Colonel Warren on Iraqi prisoner abuse that the only request he had approved was for continued segregation beyond 30 days. He testified that he never saw any other method come to his level requesting approval.

Senator LEVIN. Okay. Finally, in the annex to the Taguba Report, the document describes interrogation techniques, again, which

are permissible with certain approvals of commanders. But then it says the following, "Interrogation officer in charge will submit the memorandum for the record requesting harsh approaches for the commanding general's approval prior to employment—sleep management, sensory deprivation, isolation longer than 30 days, dogs."

Are you familiar with that description that the officer in charge will submit memoranda to the commanding general (CG) requesting harsh approaches? Are you familiar with that language, which was in the annex, but left off this document?

General ALEXANDER. Sir, those are what's under the CG's approval, part of that document you're holding. If you look in the right-hand—

Chairman WARNER. It says right here, "requires CG's approval."

Senator LEVIN. No, I'm talking about the harsh-approaches language.

General ALEXANDER. Yes, and when you read the harsh-approaches language, sir, read the—if you would read the language—

Senator LEVIN. No, I understand that. I'm talking about the characterization of this list as being harsh approaches. This is quotes. This comes from the annex in the Taguba Report.

General ALEXANDER. Right.

Senator LEVIN. It says that in an unclassified December 12 situation update—in that situation update. Have you seen that situation update?

General ALEXANDER. No, sir, I have not.

Senator LEVIN. It's that update which is included—to Miller—included as an annex to the Taguba Report. It says the document describes these techniques which are permissible, and that document, which you say you haven't seen, but which is in the annex, says that a request for harsh approaches. That's their description. You're saying harsh approaches are approved by the Geneva Conventions?

General ALEXANDER. Sir, I'm saying that when you read the interrogation manual, there are—when you look at the ways of talking to prisoners, it stems—and I have a copy of the manual that we can leave here, and when you look at it, it talks about harsh approaches, and it talks about the way that you talk to a prisoner, it talks about the direct approach. It goes all the way through all of these. As Dr. Cambone stated this morning, and others, we have gone to great extent trying to ensure that everything that we're doing is in compliance with the Geneva Conventions.

Senator LEVIN. Thank you.

General ALEXANDER. Yes, sir.

Chairman WARNER. Thank you.

Senator McCain.

Senator MCCAIN. I thank you.

General Alexander and General Burgess and General Romig, thank you for being here today.

General Alexander, maybe you can't answer this, but we have a sort of contradiction here. General Taguba, who gave, I think, an excellent testimony this morning, basically concludes that these abuses were somewhat confined to a relatively small area. Is that what you get out of it, General Alexander, as well?

General ALEXANDER. Sir, the abuses of this nature, yes, sir, that's correct.

Senator MCCAIN. But yet, on the other hand, we have reports that Ambassador Bremer complained, that Secretary Powell complained, at the highest level, that the ICRC issued a long series—a number of reports concerning prisoner abuses. Something doesn't connect there. Can you help us out on that?

General ALEXANDER. Sir, I've not seen the reports from Secretary Powell and from Mr. Bremer.

Senator MCCAIN. How about the ICRC?

General ALEXANDER. I have read the ICRC, and the key ones that are in the ICRC, when I read that, which was this week, when I looked at that, and you look at the allegations, and you look at the pictures, you immediately make the connection that what the ICRC had and what the pictures said are the event.

Senator MCCAIN. The ICRC alleged, as I understand it, that these situations were widespread, and not confined to just one small area.

General ALEXANDER. Yes, sir. But I don't know where the ICRC went. I do know that in the memo that I saw, it talked about Abu Ghraib, and it listed those allegations in Abu Ghraib that were exactly what we saw in those pictures.

Senator MCCAIN. All right. I think we need to pursue that line, because I—again, as serious as it was for Ambassador Bremer and Secretary Powell to repeatedly complain about this situation, I think it leads one to believe that it was widespread. That may not be the case.

But I want to get into a little philosophical discussion with you very quickly. Unfortunately, we don't have much time for all three of you, do you think we should have signed the Geneva Conventions for the treatment of POWs?

I'll begin with you, General Burgess.

General BURGESS. Yes, sir, I do.

General ALEXANDER. Yes, sir.

General ROMIG. Absolutely, sir.

Senator MCCAIN. Why do you think we should? Because this keeps us from getting information that may save American lives. This is a restraint by humanitarian do-gooders. Why don't we just throw them in the trash can and do whatever is necessary? We certainly have developed sophisticated techniques that we could just go after these people and get what we need, and save American lives.

General Burgess.

General BURGESS. Sir, two things. One, it applies to us, as well. Number two, we're a nation of law, sir.

Senator MCCAIN. Good point, General.

General ALEXANDER. I think, sir, one of you mentioned earlier, either last week or this week, that we hold these standards, and our military to that standard, to set a symbol for the rest of the world. Why we're here today and what we're doing today is explaining the problems that we have openly and honestly, and trying to fix those problems. We are not perfect. We make mistakes. When we identify those mistakes, get 'em out.

So when you go back to this, absolutely we should do the—

Senator MCCAIN. I'm talking about the——

General ALEXANDER.—the Geneva Conventions.

Senator MCCAIN.—extent and the problem we're facing here.

General ALEXANDER. Yes.

Senator MCCAIN. It seems to me, General, that we distinguish ourselves from our enemies by our treatment of our enemies. Would you agree with that?

General ALEXANDER. Absolutely, sir.

Senator MCCAIN. General Romig—I ask you three because you've served this Nation with distinction, and, obviously, from looking at you, you've seen incoming fire on occasion—please go ahead.

General ROMIG. Yes, sir. I agree with everything that was said. It impacts on the way our soldiers are treated—our soldiers, sailors, airmen, and marines—but it's the right thing to do, too, sir. Those are our values. That's what we stand for, those sorts of values that we see in the Geneva Conventions.

Senator MCCAIN. So, General Alexander, are we overreacting to this situation, in your view? Please be candid, and if you think we are, please say so.

General ALEXANDER. Sir, at times, sitting here, one might want to say, yes, we're overreacting. But the reality is, we are not. I think these were reprehensible acts, and I think we have to get to the bottom of it. I think if we have a problem, if it is an intel oversight problem, if it is an MP problem, or if it's a leadership problem, we have to get to the bottom of it, we have to do it honestly and objectively, and then we have to hold those who were responsible accountable. That standard is so that the rest of the countries of the world know that we will do that.

Senator MCCAIN. That way we remove the stain on those million—1.399 million men and women in the military who would never consider such behavior.

General ALEXANDER. Exactly, sir.

Senator MCCAIN. I thank the chairman. I think it's well to put this in perspective, particularly in the fact that we are going to fight other conflicts, I'm very much afraid. I'm very much afraid Americans may become prisoners. If we somehow convey the impression that we have to do whatever is necessary and humanitarian do-gooders have no place in this arena, which I believe the ICRC has an important role to play, then I think we're setting ourselves up for some very serious consequences for American fighting men and women in conflicts in the future.

I see you nodding your head, General Romig. Do you agree with that?

General ROMIG. Absolutely, sir.

Senator MCCAIN. General——

General ALEXANDER. Yes, sir.

General BURGESS. Yes, sir.

Senator MCCAIN. I thank the chairman. I thank the witnesses for their candor and for their service.

Chairman WARNER. Thank you.

I want to do a follow-up. You said you saw the material that was sent by Ambassador Bremer expressing his concern, and from the Secretary of State, is that correct?

General ALEXANDER. Sir, I said I had not seen that.

Chairman WARNER. Oh, you had not seen it.

General ALEXANDER. I have not seen that, no, sir.

Chairman WARNER. But you know it existed somewhere.

General ALEXANDER. I heard—yes, sir, in earlier testimonies, I heard that, watching the testimonies, but I had not seen the specific documents from either Secretary Powell or Mr. Bremer. I've not seen those.

Chairman WARNER. Were those transmissions in documentary form, though, to those that received them?

General ALEXANDER. I don't know, sir.

General BURGESS. Sir, I do not know.

Chairman WARNER. All right, thank you very much, because the committee is anxious to get a hold of those documents. Thank you.

Senator Kennedy.

Senator KENNEDY. Thank you very much to our panel.

I'd like to address this to General Romig. During the lunch hour, I read through this United Press International story about Arnaud de Borchgrave, who's a very experienced writer. He writes, "Long before the official reports and journalistic exposes revealing the horrific abuse of Iraqi prisoners, high-ranking American officers and the Judge Advocate General (JAG) expressed their deep concern that the civilian officials at the Pentagon were undermining the military's detention rules and regulations and ignoring interrogation procedures, even citing cases of torture. The Pentagon civilian leadership were appraised in late spring of 2003, and again in October 2004. JAG officers are quoted as telling Scott Horton, the chairman of the Committee on International Law of the Bar Association—New York Bar Association, that Feith had significantly weakened the military rules and regulations governing prisoners of war. JAG informants also blame the DOD's Chief Counsel, William Haynes, who's been recently appointed by President Bush through the Federal Appeals Court, along with Feith, for creating an atmosphere of legal ambiguity that allowed mistreatment of prisoners. These were eight JAG officers that went and spoke with Scott Horton. One deputy counsel at the Pentagon, a staunch Republican, recently resigned, as he explained, not for attribution, that right-wing ideologues are putting at risk the reputation of the U.S. military. JAG officers who spoke to Horton said civilian officials, directed by Feith, removed safeguards that were designed to prevent the abuses that the world has now witnessed. At Abu Ghraib, these safeguards should have included observations of interrogations behind two-way mirrors by JAG officers—would then be authorized to stop any misconduct on the spot."

[The information referred to follows:]

John Kennedy

**ASSOCIATION OF THE BAR OF THE CITY OF NEW YORK
COMMITTEE ON INTERNATIONAL HUMAN RIGHTS
COMMITTEE ON MILITARY AFFAIRS AND JUSTICE:**

**HUMAN RIGHTS STANDARDS APPLICABLE TO
THE UNITED STATES' INTERROGATION OF DETAINEES**

Executive Summary/Introduction

This Report is a joint effort of the Association of the Bar of the City of New York's Committees on International Human Rights and Military Affairs and Justice, undertaken to consider allegations – reported in the press and by human rights and humanitarian organizations conducting their own investigations – that individuals detained by the United States at its military and intelligence facilities in connection with the initial War in Afghanistan and the subsequent ongoing conflict in Afghanistan, are being subjected to interrogation techniques that constitute torture or cruel, inhuman or degrading treatment.¹ We note at the outset, however, that although this project was initially motivated by allegations regarding the treatment of detainees from the War in Afghanistan, the international law and human rights standards discussed herein – with the exception of Geneva Convention protections applicable only to situations of international armed conflict – apply broadly and with equal force to the treatment of detainees captured in other situations, including detainees picked up in other countries in connection with the broader “War on Terror.”² In this Report, we will examine the international legal standards governing United States military and civil authorities in interrogating detainees and propose ways of assuring that those standards are enforced.

¹ For purposes of this Report, the term “War in Afghanistan” refers to the period of international armed conflict in Afghanistan – from October 2001 to June 2002, when the Taliban was the governing force in Afghanistan, and the phrase “ongoing conflict in Afghanistan” refers to the period after June 18, 2002 when Hamid Karzai was elected as Afghanistan’s transitional head of state, and the U.S. and other international parties were operating in Afghanistan at the invitation of this new Afghanistan government. This distinction becomes important in discussing the protections afforded to detainees by the Geneva Conventions. *See* Section II of this Report.

² An assessment of the parameters and legal implications of the “War on Terror,” a term coined by the Administration, is beyond the scope of this Report.

The Alleged Interrogation Practices

These allegations first surfaced in December 2002, when the U.S. military announced that it had begun a criminal investigation into the death of a 22 year-old Afghan farmer and part-time taxi driver who had died of “blunt force injuries to lower extremities complicating coronary artery disease” while in U.S. custody at Bagram Air Force Base in Afghanistan.³ Since then, details about interrogation techniques allegedly employed at U.S. detention facilities – most of which are off-limits to outsiders and some of which are in undisclosed locations – have come from government officials speaking on the condition that they would not be identified and from the few prisoners who have been released. Some examples of “stress and duress” interrogation “techniques” reportedly being practiced by U.S. Department of Defense (“DOD”) and Central Intelligence Agency (“CIA”) personnel at U.S. detention facilities include: forcing detainees to stand or kneel for hours in black hoods or spray-painted goggles, 24-hour bombardment with lights, “false-flag” operations meant to deceive a captive about his whereabouts, withholding painkillers from wounded detainees, confining detainees in tiny rooms, binding in painful positions, subjecting detainees to loud noises, and sleep deprivation.⁴

³ Carlotta Gall, *U.S. Military Investigating Death of Afghan In Custody*, N.Y. TIMES, Mar. 4, 2003, at A14. According to the *New York Times*, another Afghan man died of a pulmonary embolism or a blood clot in the lung while in U.S. custody at Bagram on December 3, 2002. Both men died within days of arriving at Bagram. Human Rights Watch has criticized the U.S. government for failing, one year after the first two deaths at Bagram – which were classified as homicides, to release the results of its investigation. See Press Releases & Documents, Voice of America, Rights Group Criticizes U.S. Military for Treatment of Afghan Detainees (Dec. 1, 2003) (printed at 2003 WL 66801402).

⁴ See, e.g., Dana Priest & Barton Gellman, *U.S. Decries Abuse but Defends Interrogations; “Stress and Duress” Tactics used on Terrorism Suspects Held in Secret Overseas Facilities*, WASH. POST, Dec. 26, 2002, at A01; Eric Lichtblau & Adam Liptak, *Questioning to Be Legal, Humane and Aggressive, The White House Says Now*, N.Y. TIMES, Mar. 4, 2003, at A13; Jess Bravin & Gary Fields, *How do U.S. Interrogators Make A Captured Terrorist Talk*, WALL ST. J., Mar 4, 2003, at B1; Tania Branigan, *Ex-Prisoners Allege Rights Abuses*

In addition, the U.S. is reportedly “rendering” suspects to the custody of foreign intelligence services in countries where the practice of torture and cruel, inhuman or degrading treatment during interrogation is well-documented.⁵

The Administration’s Responses

The Association and others have written to U.S. government officials to ask whether there is any factual basis for these allegations and whether steps are being taken to ensure that detainees are interrogated in accordance with U.S. law and international standards prohibiting torture and “cruel, inhuman or degrading” treatment falling short of torture (“CID”).⁶

In response to inquiries from Human Rights Watch, U.S. Department of Defense General Counsel William J. Haynes has stated that: “United States policy condemns and prohibits torture” and that, when “questioning enemy combatants, U.S. personnel are required to

By U.S. Military, WASH. POST, Aug. 19, 2003, at A02. While standards and conditions of confinement – addressed by many of the international legal instruments examined in this Report – would be included in any exhaustive inquiry into the treatment of detainees at U.S. detention centers, in this Report we are focusing more narrowly on the legality of interrogation methods.

⁵ Captives have reportedly been “rendered” by the U.S. to Jordan, Egypt, Morocco, Saudi Arabia and Syria, in secret and without resort to legal process. *See, e.g.*, Peter Finn, *Al Qaeda Recruiter Reportedly Tortured; Ex-Inmate in Syria Cites Others’ Accounts*, WASH. POST, Jan. 31, 2003, at A14; Dana Priest and Barton Gellman, *U.S. Decries Abuse but Defends Interrogations: “Stress and Duress” Tactics used on Terrorism Suspects Held in Secret Overseas Facilities*, WASH. POST, Dec. 26, 2002, at A01; Rajiv Chandrasekaran & Peter Finn, *U.S. Behind Secret Transfer of Terror Suspects*, WASH. POST, Mar. 11, 2002, at A01.

⁶ *See, e.g.*, Letter from Kenneth Roth, Executive Director, Human Rights Watch to President George W. Bush (Dec. 26, 2002) (*available at* <http://www.hrw.org/press/2002/12/us1227.htm>); Letter from Human Rights Groups to President George W. Bush (Jan. 31, 2003); Letter from Ernest Duff, The National Consortium of Torture Treatment Programs to President George W. Bush (Feb. 5, 2003); Letter from Sen. Patrick Leahy to Condoleezza Rice (June 2, 2002); Letter from ABCNY Committees on Military Affairs and Justice and International Human Rights to Scott W. Muller, General Counsel, CIA (June 4, 2003); Letter from Sen. Patrick J. Leahy to William J. Haynes, II, General Counsel, DOD (Sept. 9, 2003).

follow this policy and applicable laws prohibiting torture.”⁷ CIA General Counsel Scott W. Muller, citing to the need to protect intelligence sources and methods, has responded to our inquiries by stating only that “in its various activities around the world the CIA remains subject to the requirements of U.S. law” and that allegations of unlawful behavior are reported by the CIA to the Department of Justice and are subject to investigation.⁸

In response to an inquiry made by U.S. Senator Patrick J. Leahy regarding U.S. policy, Haynes stated that U.S. policy entails “conducting interrogations in a manner that is consistent with the Convention Against Torture and Other Cruel, Inhuman, or Degrading Treatment or Punishment (“CAT”), as ratified by the U.S. in 1994, and with the Federal anti-torture statute, 18 U.S.C. §§ 2340 - 2340A, which Congress enacted to fulfill U.S. obligations under the CAT.”⁹ Haynes also stated that U.S. policy is “to treat all detainees and conduct all interrogations, wherever they may occur, in a manner consistent with” the U.S. obligation, pursuant to Article 16 of CAT, namely, “to prevent other acts of cruel, inhuman, or degrading

⁷ See Letter from William J. Haynes II, General Counsel, DOD, to Kenneth Roth, Executive Director, Human Rights Watch (Apr. 2, 2003). The Administration’s use of the terms “enemy combatants” and “unlawful combatants” to detain persons indefinitely without administrative or judicial proceedings is novel.

⁸ See Letter from Scott W. Muller, General Counsel, CIA to Miles P. Fischer and Scott Horton, chair of the Committee on Military Affairs and Justice and then-chair of the Committee on International Human Rights, respectively (June 23, 2003). A CIA senior official has informally indicated that the agency complies with applicable law in reliance on the advice of its legal staff. However, we have been unable to confirm what legal advice has been given by CIA counsel or what means have been used to assure compliance with that advice.

⁹ See Letter from William J. Haynes II, General Counsel, DOD, to Sen. Patrick J. Leahy (June 25, 2003). At the November 20-21, 2003, Annual Review of the Field of National Security Law conference of the American Bar Association’s Standing Committee on National Security Law, Muller stated publicly in response to a question by a member of the Committee on Military Affairs and Justice that Haynes’ June 25, 2003 letter to Sen. Leahy articulates the policy position of “the entire U.S. government.” Copies of the correspondence cited in fn. 6-9 are attached to this Report as Appendix A.

treatment or punishment which do not amount to torture” insofar as such treatment is “prohibited by the Fifth, Eighth, and/or Fourteenth Amendments.”¹⁰ Haynes assured Senator Leahy “that credible allegations of illegal conduct by U.S. personnel will be investigated and, as appropriate, reported to proper authorities.”¹¹ Furthermore, Haynes stated that the U.S. does not “expel, return (*refouler*) or extradite individuals to other countries where the U.S. believes it is ‘more likely than not’ that they will be tortured,” that “United States policy is to obtain specific assurances from the receiving country that it will not torture the individual being transferred to that country,” and that “the United States would take steps to investigate credible allegations of torture and take appropriate action if there were reason to believe that those assurances were not being honored.”¹²

Both Haynes and Muller have declined, however, to give details concerning the specific interrogation methods used by U.S. personnel at U.S. military and CIA detention facilities.

Legal Standards Prohibiting Torture and Cruel, Inhuman or Degrading Treatment

Although we are not in a position to investigate the factual basis for the allegations of torture and cruel, inhuman or degrading interrogation practices at U.S. detention facilities that have been made, we can describe the legal principles which should guide our military and intelligence personnel in their conduct. Accordingly, in this Report we examine the international and U.S. law standards against which the interrogation practices used on detainees should be assessed. We also address the question of whether there are any circumstances posed

¹⁰ *Id.*

¹¹ *Id.*

¹² *Id.*

by the post-September 11 world in which abrogation of our country's obligations to prevent and punish torture and cruel, inhuman or degrading treatment should be permitted in the interrogation of terrorist suspects.

The Convention Against Torture

First and foremost, the U.S. obligation to prohibit and prevent the torture and cruel, inhuman or degrading treatment of detainees in its custody is set forth in the Convention Against Torture And Other Cruel, Inhuman, or Degrading Treatment ("CAT"), to which the U.S. is a party.¹³ When the U.S. ratified CAT in 1994, it did so subject to a reservation providing that the U.S. would prevent "cruel, inhuman or degrading treatment" insofar as such treatment is prohibited under the Fifth, Eighth, and/or Fourteenth Amendments.¹⁴ Thus, the U.S. is obligated to prevent not only torture, but also conduct considered cruel, inhuman or degrading under international law if such conduct is also prohibited by the Fifth, Eighth and Fourteenth Amendments. In interpreting U.S. obligations, we look to the U.N. Committee Against Torture's interpretations of CAT as well as U.S. case law decided in the immigration and asylum law context, under the Alien Tort Claims and Torture Victim Protection Acts and concerning the treatment of detainees and prisoners under the Fifth, Eighth and/or Fourteenth Amendments. We also examine the procedural mechanisms available under U.S. law to punish violations of CAT – including prosecution under federal criminal law (18 U.S.C. §§ 2340 - 2340A) and the Uniform Code of Military Justice ("UCMJ").

¹³ Convention Against Torture and Other Cruel, Inhuman or Degrading Treatment or Punishment, *opened for signature* Feb. 4, 1985, G.A. Res. 46, U.N. GAOR 39th Sess., Supp. No. 51, at 197, U.N. Doc. A/RES/39/708 (1984), *reprinted in* 23 I.L.M. 1027 (1984) ("CAT").

¹⁴ 136 Cong. Rec. S17486-01, 1990 WL 168442.

Other International Legal Standards which Bind the United States

While there is a dearth of U.S. case law applying CAT's prohibition against torture and cruel, inhuman or degrading treatment in the interrogation context, there is a wealth of international law sources which offer guidance in interpreting CAT. Some of these international legal standards are, without question, binding on the U.S., such as: the International Covenant on Civil and Political Rights (the "ICCPR"),¹⁵ the law of *jus cogens* and customary international law. Another international legal instrument which has been ratified by the U.S. and is relevant to the interrogation practices being examined by this Report is the Inter-American Declaration on the Rights and Duties of Man.¹⁶ Other sources, such as the European Convention for the Protection of Human Rights and Fundamental Freedoms,¹⁷ also provide guidance.

The applicability of the Geneva Conventions to the detainees from the War in Afghanistan, however, presents a more contentious issue. The Administration's official position is that the Geneva Conventions do not apply to Al Qaeda detainees, and that neither the Taliban nor Al Qaeda detainees are entitled to prisoner of war ("POW") status thereunder. Nevertheless, the Administration has stated that it is treating such individuals "humanely and, to the extent appropriate and consistent with military necessity, in a manner consistent with the principles of the Third Geneva Convention of 1949," and that the detainees "will not be subjected to physical

¹⁵ G.A. Res. 2200A (XXI), U.N. GAOR, 21st Sess., Supp. No. 16, at 52, U.N. Doc. A/6316.

¹⁶ O.A.S. RES. XXX, OEA/Ser. L.V/II. 82 Doc. Rev. 1, at 17.

¹⁷ 213 U.N.T.S. 221.

or mental abuse or cruel treatment.”¹⁸ The Administration has never explained how it determines what interrogation techniques are “appropriate” or “consistent with military necessity,” or how it squares that determination with U.S. obligations under human rights and customary international law. For POW and civilian detainees who meet the relevant criteria of Geneva Convention (III) Relative to the Treatment of Prisoners of War (“Geneva III”) and Geneva Convention (IV) Relative to the Protection of Civilian Persons in Time of War (“Geneva IV”), respectively, all coercion is prohibited.¹⁹ Moreover, any detainee whose POW status is in doubt is entitled to a hearing and determination by a competent tribunal and, pending such determination, any such detainee must be treated as a POW. Concern for the safety of U.S. forces weighs in favor of extending POW status liberally. At a minimum, all detainees – regardless of POW or civilian status – are entitled to humane treatment and prompt hearings under human rights and customary international law, including the protections of Article 3 common to all four Geneva Conventions (“Common Article 3”) and Article 75 of the Protocol Additional to the Geneva Conventions of 12 August 1949 and Related to the Protection of Victims of International Armed Conflicts (“Additional Protocol I”).²⁰ We urge the U.S. to promptly establish proper screening procedures for all detainees, whether or not they served with forces that met the specific criteria of Geneva III.

¹⁸ See *White House Fact Sheet: Status of Detainees at Guantánamo* (Feb. 7, 2002) (available at <http://www.whitehouse.gov/news/releases/2002/02/print/20020207-13.html>).

¹⁹ Geneva Convention (III) Relative to the Treatment of Prisoners of War, 6 U.S.T. 3316, 1949 U.S.T. LEXIS 483 (“Geneva III”); Geneva Convention (IV) Relative to the Protection of Civilian Persons in Time of War, 6 U.S.T. 3516, 1949 U.S.T. LEXIS 434 (“Geneva IV”).

²⁰ Additional Protocol I, *reprinted in* 16 I.L.M. 1391. While neither the United States nor Afghanistan is a signatory to Additional Protocol I, it is generally acknowledged that certain provisions are binding as a matter of customary international law. And although the terms of Common Article 3 specifically limit its scope to internal conflicts, it is considered by customary international law to have broader scope.

Legal Standards which the United States Should Look to for Guidance

Other relevant sources of law, such as the seminal 1999 Israeli Supreme Court decision on interrogation methods employed by the Israeli General Security Service, *Judgment Concerning The Legality Of The General Security Service's Interrogation Methods*,²¹ and decisions of the European Court of Human Rights, although not legally binding on the U.S., also offer useful guidance in our interpretation of CAT. These foreign decisions indicate that the “War on Terror” is not unprecedented. As the Israeli and Northern Ireland experiences demonstrate, the U.S. is not the only country to have faced terrorism within its borders, despite the unique tragedy of September 11 and the potential threat of weapons of mass destruction that could expand the loss of life by orders of magnitude. We can and should learn from the experience of other countries whose courts have grappled with the need to permit effective interrogation while at the same time upholding the standards of human rights and the rule of law.

Standards in the Time of Terror

There is an inherent tension between the need to obtain potentially life-saving information through interrogation of terrorist suspects and the legal requirement of upholding the standards set forth in CAT. We grappled with the question of whether there are any circumstances under which torture or cruel, inhuman or degrading treatment would be permissible in a post-September 11 world. While we acknowledge the real danger posed to the United States by Al Qaeda and other terrorist organizations, we concluded that there are no such exceptions to CAT’s absolute prohibition of torture.

Condoning torture under any circumstances erodes one of the most basic principles of international law and human rights and contradicts our values as a democratic state.

²¹ 38 I.L.M. 1471 (Sept. 6, 1999).

Permitting the abuse of detainees in U.S. custody, perhaps under so-called “torture warrants,” not only harms the detainees themselves; it compromises the moral framework of our interrogators and damages our society as a whole. If U.S. personnel are allowed to engage in brutal interrogation methods which denigrate the dignity and humanity of detainees, we sanction conduct which we as a nation (along with the international community) has clearly determined is wrong and immoral. Accordingly, we unanimously condemn the torture of detainees under any circumstances. We note that U.S. constitutional jurisprudence on “cruel, inhuman or degrading” treatment, which has been made relevant to CAT by the U.S. reservation, is an extremely important source of guidance on this subject. On the other hand, much of this jurisprudence evolved in the context of domestic criminal justice administration, and how these precedents would be applied in a case arising out of the interrogation and detention covered by this Report is, in the absence of more definitive authority, a matter of some speculation.

Recommendations

We applaud the statements in William Haynes’ June 25, 2003 letter to Senator Leahy affirming the policy of the U.S. regarding its commitment to CAT. To make that policy meaningful, we make the following recommendations:

1. **Training and Education.** All law enforcement personnel, civilian or military, medical personnel, public officials and other persons who may be involved in the custody, interrogation or treatment of anyone under any form of detention or imprisonment should be informed and educated regarding the prohibition against torture and cruel, inhuman or degrading treatment, as applied in practice. This requires, as provided in Article 11 of CAT, that the U.S. keep under systematic review interrogation rules, instructions, methods and practices as

well as arrangements for the custody and treatment of such detainees.²² Above all, commanders should not condone non-compliance nor permit an environment in which troops are encouraged to provide lip service to compliance but yet think that non-compliance is acceptable.

Given that CIA personnel are not generally subject to the UCMJ, possibly not even when accompanying the armed forces in the field, special procedures should be available to provide reasonable assurance that compliance with CAT is being taught and maintained by intelligence agencies. That assurance might best be provided by the applicable committees of the Congress exercising oversight responsibility in conjunction with the inspectors general of the applicable agencies.

2. Prompt Investigation of Violations. As required by Article 12 of CAT, the U.S. must ensure that allegations of abusive conduct are taken seriously and are fully and impartially investigated.²³ Thus, any individual who alleges that he or she has been subjected to torture must be provided with a meaningful opportunity to complain to, and to have his/her case promptly and impartially examined by, competent authorities. Steps must be taken to ensure that the complainant and witnesses are protected against all ill-treatment and intimidation.

3. Expand the Scope and Reach of Section 2340. Consistent with its obligation under Article 4 of CAT to ensure that all acts of torture are offenses under its criminal law²⁴ – and since 18 U.S.C. § 2340 does not, by its terms, apply to acts constituting torture committed in extraterritorial detention centers under U.S. jurisdiction – the U.S. must expand the

²² CAT, Art. 11.

²³ *Id.*, Art. 12.

²⁴ *Id.*, Art. 4.

geographic reach of Section 2340 so that the prescriptions of CAT are applicable at all U.S. detention centers.

4. Fully Utilize the UCMJ. The U.S. must more fully utilize the procedures and protections available under the UCMJ to prosecute all violations of CAT by the armed forces or others subject to the UCMJ.

5. Independent Investigation of Human Rights Compliance in Other Countries. As provided by Article 3 of CAT, the U.S. must not “render” detainees to other countries where there are substantial grounds for belief that the detainees would be in danger of being subjected to torture.²⁵ In determining whether there are “substantial grounds for belief” that a detainee would be in danger of torture if rendered to another country, U.S. authorities must take into account all the relevant considerations concerning that country, including independently investigating whether there exists a consistent pattern of gross, flagrant or mass violations of human rights in the country.²⁶

6. Grant POW Status to Detainees Whose Status is in Doubt and Possibly as a Matter of Policy. The U.S. should adhere to Geneva III’s requirement that any detainee whose POW status is in “doubt” is entitled to POW status – and, therefore, cannot be subjected to

²⁵ *Id.*, Art. 3.

²⁶ For example, a lawsuit was recently filed by the Center for Constitutional Rights on behalf of Maher Arar, a Syrian-born Canadian citizen alleging that U.S. authorities deported him to Jordan in September 2002, where he was driven across the border and handed over to Syrian authorities. The Arar Complaint alleges that, although the U.S. Department of State’s 2003 Country Reports designated Syria as a government that practices systemic torture, U.S. officials allegedly relied on assurances from the Syrian government that Arar would not be tortured. Arar has alleged that he was tortured repeatedly in a Syrian prison for 10 months, often with cables and electrical cords. *See* Complaint in *Maher Arar v. John Ashcroft, et al.* (available at http://www.ccr-ny.org/v2/legal/September_11th/docs/ArarComplaint.pdf).

coercive treatment – until a “competent tribunal,” which must be convened promptly, determines otherwise.²⁷ We urge the U.S. to consider the policy grounds for extending POW treatment to regular force combatants, whether or not legally required to do so, as it has done in prior conflicts.

7. Prompt Screening and Hearings for All Detainees. In keeping with the spirit of the Geneva Conventions and human rights law, we urge the U.S. to provide proper screening procedures and hearings to all detainees.²⁸

We now turn to a more detailed discussion of the international standards applicable to interrogation procedures.

THE CONVENTION AGAINST TORTURE

The U.N. Convention Against Torture and Other Cruel, Inhuman or Degrading Treatment or Punishment (“CAT”) is the primary source of international law relevant to the treatment of detainees.²⁹ CAT has been ratified by the U.S., and its prohibitions against torture and cruel, inhuman or degrading treatment or punishment have been implemented in our domestic law.

Specifically, U.S. law implements CAT’s prohibition against torture in the immigration and asylum contexts, under the Alien Tort Claims and Torture Victim Protection

²⁷ Geneva III, Art. 5.

²⁸ We note that the Department of Defense has recently circulated for comment administrative review procedures for enemy combatants at Guantánamo Bay Naval Base. *See* <http://www.defenselink.mil/news/Mar2004/d20040303ar.pdf>. While welcoming such a review process, we do not consider it to meet the requirement for status determination under the Geneva Conventions.

²⁹ *Supra* note 13.

Acts, by criminal statute and under the UCMJ. Under CAT, the U.S. is also obligated to prevent “cruel, inhuman or degrading treatment or punishment” as defined in international law; however, by express reservation, the U.S. interprets this obligation in keeping with standards of treatment required by the Fifth, Eighth and Fourteenth Amendments. Accordingly, under CAT, American military and intelligence personnel involved in the interrogation of detainees may not torture those detainees, nor may they subject them to cruel, inhuman or degrading treatment that is, or would be, forbidden under the Fifth, Eighth and/or Fourteenth Amendments.

CAT’s Definitions of – and Prohibitions against – Torture and Cruel,
Inhuman or Degrading Treatment

CAT defines and prohibits torture, as defined, and cruel, inhuman or degrading treatment or punishment in general terms. In addition, it also sets out steps ratifying countries must take to prevent, investigate, and criminalize acts of torture;³⁰ prohibits the extradition or other rendering (also known as “*refoulement*”) of a person to a country that would likely subject such person to torture;³¹ creates a Committee to oversee the implementation of CAT by ratifying countries; and sets forth procedures for inquiries, individual communications, and inter-State complaints.

CAT’s preamble acknowledges that torture and other cruel, inhuman or degrading treatment or punishment are already prohibited under Article 5 of the Universal Declaration of Human Rights and Article 7 of the ICCPR. Thus, rather than simply mirroring the prohibitions

³⁰ *Id.* Article 4.1 states: “Each State Party shall ensure that all acts of torture are offences under its criminal law. The same shall apply to an attempt to commit torture and to an act by any person which constitutes complicity or participation in torture.”

³¹ *Id.* Article 3.1 states: “No State Party shall expel, return (*‘refouler’*) or extradite a person to another State where there are substantial grounds for believing that he would be in danger of being subjected to torture.”

from these instruments, Article 1 of CAT provides additional guidance to states parties in preventing and punishing torture by setting forth an explicit definition of torture:

...torture means any act by which severe pain or suffering, whether physical or mental, is intentionally inflicted on a person for such purposes as obtaining from him or a third person information or a confession, punishing him for an act he or a third person has committed or is suspected of having committed, or intimidating or coercing him or a third person, or for any reason based on discrimination of any kind, when such pain or suffering is inflicted by or at the instigation of or with the consent or acquiescence of a public official or other person acting in an official capacity. It does not include pain or suffering arising only from, inherent in or incidental to lawful sanctions.

This definition makes it clear that the result of torture need not be physical pain or suffering, but can also be mental. In addition, torture is defined to include such conduct undertaken for the purpose of obtaining information. Finally, the prohibition is not directed at private citizens, acting independently of government; it applies rather to acts committed by government officials and agents, or persons acting with official consent or acquiescence.

CAT's prohibition of torture is absolute. An order from a superior officer or a public authority may not be invoked as a justification of torture. Specifically, Article 2(2) provides: "No exceptional circumstances whatsoever, whether a state of war or a threat of war, internal political instability or any other public emergency, may be invoked as a justification of torture."

Although CAT does not provide a definition of CID punishment or treatment, Article 16 requires ratifying countries to prevent "other acts of cruel, inhuman or degrading treatment or punishment which do not amount to torture...." This language suggests that cruel, inhuman or degrading treatment is on a continuum with torture.

CAT requires each signatory state to prevent the commission of the prohibited acts within any territory under the state's jurisdiction. Specifically, each ratifying country must ensure that any official who may be involved in the interrogation of anyone under any form of detention or imprisonment is informed of and educated about the prohibitions against torture and cruel, inhuman or degrading treatment. CAT also requires each ratifying country to ensure that allegations of torture and CID treatment are fully and impartially investigated. *See* CAT Articles 12 and 16(1).

CAT's Prohibition against Torture and CID Treatment as Interpreted
by the U.N. Committee Against Torture
The U.N. Committee Against Torture, created by CAT, is charged with

monitoring implementation of the treaty by ratifying countries through the determination of individual complaints, considering country reports submitted under CAT, and resolving inter-State disputes. Given the importance of international standards in interpreting U.S. domestic law³² as well as the recent *Lawrence v. Texas* decision, in which the U.S. Supreme Court expressly looked to foreign and international law for guidance,³³ U.N. Committee decisions are relevant to the assessment of whether the actions of U.S. personnel involved in the interrogation of detainees constitute torture or cruel, inhuman or degrading treatment.

³² *See Murray v. The Charming Betsy*, 6 U.S. (2 Cranch) 64, 118 (1804) (a statute "ought never to be construed to violate the law of nations, if any other possible construction remains"). *See also United States v. P.L.O.*, 695 F. Supp. 1456, 1468 (S.D.N.Y. 1988) (noting "the lengths to which our courts have sometimes gone in construing domestic statutes so as to avoid conflict with international agreements...").

³³ *Lawrence v. Texas*, 539 U.S. 558 (2003).

The U.N. Committee has concluded that the following acts³⁴ constitute torture under CAT:

- daily beatings and detaining someone in a small, uncomfortable space for two weeks;³⁵
- forcing someone to sleep on the floor of a cell while handcuffed following interrogation;³⁶
- in severe cases, sleep deprivation;³⁷ and
- the threat of torture.³⁸

Furthermore, the U.N. Committee has recommended that the use of a blindfold during questioning be expressly prohibited.³⁹ More generally, the U.N. Committee has expressed concern that States have defined torture too narrowly, covering only “systematic blows or other violent acts.”⁴⁰ The U.N. Committee has also expressed concern whether the penal law of one

³⁴ This list is by no means comprehensive. Practices were selected for inclusion here because of their similarity to the practices allegedly used by U.S. agents with respect to detainees held in connection with the War in Afghanistan and the ongoing conflict in Afghanistan. The findings and concluding observations of the Committee Against Torture are available at <http://www.unhchr.ch/tbs/doc.nsf>.

³⁵ *Case of A. (name withheld) v. The Netherlands*, Committee Against Torture, Comm. No. 91/1997 (1998), U.N. Doc. No. CAT/C/21/D/91/1997.

³⁶ *See Inquiry under Article 20: Committee Against Torture, Findings concerning Peru (2001)*, U.N. Doc. No. A/56/44, at para. 35.

³⁷ *Concluding Observations concerning Republic of Korea (1996)*, U.N. Doc. No. A/52/44, at para. 56.

³⁸ *Concluding Observations concerning New Zealand (1993)*, U.N. Doc. No. A/48/44, at para. 148.

³⁹ *See Inquiry Under Article 20: Committee Against Torture, Findings concerning Turkey (1993)*, U.N. Doc. No. A/48/44/Add.1, at para. 48.

⁴⁰ *Concluding Observations concerning Azerbaijan (2003)*, U.N. Doc. No. CAT/C/CR/30/1, at para. 5(b).

State was too narrow in defining torture because it failed to prohibit “certain aspects of torture, such as psychological pressure, threats and intimidation.”⁴¹

The U.N. Committee has found that the following acts amount to cruel, inhuman or degrading treatment or punishment under CAT:

- depriving someone of food and/or water;⁴²
- in some cases, binding someone in a restraint chair;⁴³
- the use by prison authorities of instruments of physical restraint that may cause unnecessary pain and humiliation;⁴⁴ and
- long periods of detention (two weeks or more) in detention cells that are sub-standard (this conduct may amount to torture if the period of detention is extremely long).⁴⁵

The U.N. Committee has found that the following acts may amount to torture when used in combination with other forms of CID:

- being restrained in very painful conditions;
- being hooded;
- the sounding of loud music for prolonged periods;
- sleep deprivation for prolonged periods;

⁴¹ Concluding Observations concerning Germany (1993), U.N. Doc. No. A/48/44, at para. 167.

⁴² *Id.*; see also Concluding Observations concerning New Zealand (1998), U.N. Doc. No. A/53/44, at para. 175.

⁴³ Concluding Observations concerning the United States (2000), U.N. Doc. No. A/55/44, at para. 179(e).

⁴⁴ Concluding Observations concerning Australia (2000), U.N. Doc. No. A/56/44, at para. 52(b).

⁴⁵ *Supra* note 36.

- violent shaking; and
- using cold air to chill.⁴⁶

In sum, the U.N. Committee Against Torture has indicated that the classification of treatment as CID or torture is often a matter of severity, intensity, and the totality of the circumstances. Combining several forms of cruel, inhuman or degrading treatment will frequently amount to torture, and ratifying countries are required under CAT to refrain from all such practices, whether they reach the level of severity to be considered torture or not. Thus, according to U.N. Committee jurisprudence, alleged interrogation practices such as forcing detainees to stand or kneel for hours in black hoods or spray-painted goggles, 24-hour bombardment with lights, binding detainees in painful positions, withholding painkillers from wounded detainees, and subjecting detainees to loud noises and sleep deprivation, at a minimum, constitute cruel, inhuman or degrading treatment and may, depending on the circumstances, rise to the level of torture. U.N. Committee decisions critical of blindfolding, psychological pressure and threats and intimidation strongly suggest that “false-flag” operations meant to deceive detainees about their whereabouts and “stress and duress” interrogation techniques are also prohibited.

U.S. Law Implementing CAT's Prohibitions against Torture and Cruel, Inhuman or Degrading Treatment or Punishment

The Senate adopted a resolution of advice and consent to U.S. ratification of CAT, subject to the declaration that it be deemed non-self-executing, on October 27, 1990.⁴⁷

⁴⁶ These techniques were found by the Committee to constitute “breaches of article 16 and also constitute torture as defined in article 1 of the Convention. This conclusion is particularly evident where such methods of interrogation are used in combination, which appears to be the standard case.” Concluding Observations concerning Israel (1997), U.N. Doc. No. A/52/44, at para. 257.

The U.S. ratified CAT in October 1994, and CAT entered into force with respect to the United States on 20 November 1994.⁴⁷ The implementation in U.S. immigration, extradition, criminal and civil tort law of CAT's prohibition against torture, as well as the express application of U.S. constitutional standards to CAT's prohibition against CID treatment, indicates that many of the interrogation practices allegedly being used by the U.S. against detainees may be prohibited under international and U.S. law.

U.S. Understandings and Reservations in Ratifying CAT

The United States conditioned its ratification of CAT upon certain understandings related to CAT's definition of torture in Article 1. In one such understanding, the U.S. specified that mental pain or suffering within the meaning of "torture" refers to prolonged mental harm caused by or resulting from: (1) the intentional infliction or threatened infliction of severe physical pain or suffering; (2) the administration or application, or threatened administration or application, of mind-altering substances or other procedures calculated to disrupt profoundly the senses or the personality; (3) the threat of imminent death; or (4) the threat that another person

⁴⁷ See 136 CONG. REC. 36,198 (daily ed. Oct. 27, 1990). The instrument of ratification included the declaration that "the provisions of Articles 1 through 16 of [CAT] are not self-executing." See United Nations Treaty Collection: Declarations and Reservations, (available at http://www.unhcr.ch/html/menu3/b/treaty12_asp.htm).

In the case of a self-executing treaty, "no domestic legislation is required to give [it] the force of law in the United States." *Trans World Airlines, Inc. v. Franklin Mint Corp.*, 466 U.S. 243, 252 (1984). By contrast, a non-self-executing treaty is one that "must be implemented by legislation before it gives rise to a private cause of action." *Mannington Mills, Inc. v. Congoleum Corp.*, 595 F.2d 1287, 1298 (3d Cir. 1979).

⁴⁸ See Ratification Status for CAT, United States of America (available at www.unhcr.ch). The U.S. has not opted out of the inquiry procedure under Article 20. It has entered a declaration accepting the interstate complaint procedure set up by Article 21. The U.S. has not, however, accepted the competence of the Committee under Article 22 to receive and consider complaints on behalf of individuals subject to its jurisdiction who claim to be victims of a violation of CAT.

will imminently be subjected to death, severe physical pain or suffering, or the administration or application of mind-altering substances or other procedures calculated to disrupt profoundly the senses or the personality.⁴⁹ Another U.S. understanding pertains to defects in criminal procedure: non-compliance with applicable legal procedural standards (such as Miranda warnings) does not per se constitute “torture.”⁵⁰

When ratifying CAT, the United States also took the following reservation: “the United States considers itself bound by the obligation under Article 16 to prevent ‘cruel, inhuman or degrading treatment or punishment,’ only insofar as the term ‘cruel, inhuman or degrading treatment or punishment’ means the cruel, unusual and inhumane treatment or punishment prohibited by the Fifth, Eighth, and Fourteenth Amendments to the Constitution of the United States.”⁵¹

The Implementation of CAT’s Prohibition against
Torture in U.S. Legislation, Regulation and Case Law
CAT’s prohibition of official acts amounting to torture has been implemented in

the United States through legislation, regulations and case law pertaining to, *inter alia*, (1) immigration, (2) claims of torture in removal and extradition proceedings, (3) criminal sanctions for torture, and (4) tort claims alleging torture. Through the application of these

⁴⁹ See 136 CONG. REC. S17486-01 (daily ed. Oct. 27, 1990).

⁵⁰ See 136 CONG. REC. 36192, 36198 (daily ed. Oct. 27, 1990).

⁵¹ Under international law, reservations are invalid if they violate the “object and purpose” of the treaty. See Vienna Convention on the Law of Treaties, *opened for signature* May 23, 1969, 1155 U.N.T.S. 331, at Art. 19(c). This Report assumes that the U.S. reservation with respect to Article 16 of CAT is valid.

implementing laws and regulations, U.S. courts have interpreted CAT's substantive provisions in a variety of contexts.⁵²

U.S. Immigration Law and Torture

As previously noted, all countries that ratify CAT are obligated to ensure that detainees are not deported or extradited to countries where they are likely to be tortured. In 1998, the United States enacted the Foreign Affairs Reform and Restructuring Act of 1998, § 2242, Pub. L. No. 105-277, Div. G, 112 Stat. 2681, 2681-822 (Oct. 21, 1998) (the "FARR Act"), implementing this obligation. In 1999, the Immigration and Naturalization Service ("INS") promulgated regulations effectuating the FARR Act in the immigration and asylum context, providing aliens in exclusion, deportation or removal proceedings with grounds to seek withholding of removal based on CAT. *See* 8 C.F.R. § 208.18 (2004), *et seq.* These regulations incorporate CAT's definition of torture verbatim, with the following qualification: "Torture is an extreme form of cruel and inhuman treatment and does not include lesser forms of cruel, inhuman or degrading treatment or punishment that do not amount to torture." *See* 8 C.F.R. § 208.18(a)(2) (2004). These regulations further define mental pain or suffering consistently with the U.S. understandings to CAT, and exclude from the definition of torture acts which result in "unanticipated or unintended severity of pain and suffering." *See* 8 C.F.R. § 208.18(a)(5) (2004).

A number of federal court cases and Board of Immigration Appeals ("BIA") decisions address torture claims in the immigration context. The BIA has held that the following abuses of detainees and prisoners, for example, amount to torture: "suspension for long periods

⁵² Because the focus of this Report is on what laws apply to agents of the United States government in detention centers located outside of United States territory, this discussion does not examine state or federal penal or civil rights statutes that would also apply to interrogation occurring on American soil.

in contorted positions, burning with cigarettes, sleep deprivation, and...severe and repeated beatings with cables or other instruments on the back and on the soles of the feet,'...beatings about the ears, resulting in partial or complete deafness, and punching in the eyes, leading to partial or complete blindness." *Matter of G-A-*, 23 I & N Dec. 366, 370 (BIA 2002) (internal citations omitted).⁵³ Furthermore, persons seeking asylum or withholding of removal have successfully challenged deportation under Sections 208 and 241(b)(3) of the Immigration & Nationality Act ("INA") when they have a well-founded fear of future persecution. Although "persecution" is not defined in the INA, it is understood to encompass treatment falling short of torture.

U.S. Extradition of Fugitives Who Face Threat of Torture

In the extradition context, torture claims are governed by regulations enacted by the Department of State under the FARR Act. Under these regulations, individuals sought for extradition may present a claim that they are likely to be tortured if surrendered to the requesting state. These claims are considered by the U.S. Secretary of State, who is responsible for implementing CAT's obligation not to extradite an individual to a State where he or she is in danger of being subject to torture. Specifically, section 95 of 22 C.F.R. (2004) provides, in relevant part, that the Secretary of State must consider whether a person facing extradition from the U.S. "is more likely than not" to be tortured in the State requesting extradition, and that appropriate policy and legal offices must review and analyze the information relevant to the

⁵³ This had also been the position of the Ninth Circuit. See *Al-Safer v. INS*, 268 F.3d 1143 (9th Cir. 2001) (holding that severe beatings and cigarette burns sustained over periods of days, weeks and months constitutes torture). More recently, however, the Ninth Circuit has held that neither serious persecution (e.g., threats, unjust charges, fines, illegal searches and seizures) nor verbal abuse alone amount to torture. See *Gui v. INS*, 280 F.3d 1217 (9th Cir. 2002); *Quant v. Ashcroft*, 2003 U.S. App. LEXIS 6616 (9th Cir. 2003).

torture allegation. The extradition regulations, and the decisions interpreting them,⁵⁴ demonstrate that U.S. administrative bodies and courts view CAT's prohibition against extradition to torture as binding on the U.S. even when the extraditable individual is accused of wrongdoing.

U.S. Implementation of CAT's Criminal Law Requirements

18 U.S.C. §§ 2340 and 2340A were enacted to fulfill CAT's requirement that each ratifying country criminalize all acts of torture, including attempts to commit torture and complicity in torture.⁵⁵ Section 2340 defines torture as:

an act committed by a person acting under the color of law specifically intended to inflict severe physical or mental pain or suffering (other than pain or suffering incidental to lawful sanctions) upon another person within his custody or physical control. . .

"Severe mental pain or suffering" is also defined, using the same wording as the U.S. understandings concerning Article 1 of CAT set forth in Section I(C)(1) above. *See* 18 U.S.C. § 2340. As discussed further below, however, this statute applies only to U.S. nationals (or others present in the U.S.) who have committed or attempted or conspired to commit acts of torture "outside of the United States."⁵⁶

⁵⁴ *See, e.g., Cornejo-Barreto v. Seifert*, 218 F.3d 1004, 1016-17 (9th Cir. 2000) (individuals certified as extraditable by the Secretary of State who fear torture may petition for judicial review of the Secretary's decision using CAT standards protecting against *non-refoulement*); *Mu-Xing Wang v. Ashcroft*, 320 F.3d 130 (2d Cir. 2003) (following *Cornejo-Barreto's* holding that habeas review is available for CAT claims, but in the context of removal); *Ogbudimkpa v. Ashcroft*, 342 F.3d 207 (3d Cir. 2003) (same).

⁵⁵ The Senate Committee on the Judiciary acknowledged the relationship of 18 U.S.C. § 2340 to CAT and the Torture Victim Protection Act in a 2002 report. *See* S. REP. NO. 107-44 (2002), at 10-11.

⁵⁶ A restrictive interpretation of the scope of the statute is found in the U.S. Dept. of Justice, Criminal Resource Manual 20 (Oct. 1997), which provides: "Section 2340A of Title 18,

U.S. Case Law Interpretations of Torture in Tort Claims

Two U.S. statutes provide for civil suits against those who commit acts of torture

abroad. The Alien Tort Claims Act of 1789 (“ATCA”), 28 U.S.C. § 1350, states that “[t]he district courts shall have original jurisdiction of any civil action by an alien for a tort only, committed in violation of the law of nations or a treaty of the United States.” The Torture Victim Protection Act of 1991 (“TVPA”), 28 U.S.C. § 1350, provides that:

[a]n individual who, under actual or apparent authority, or color of law, of any foreign nation – (1) subjects an individual to torture shall, in a civil action, be liable for damages to that individual; or (2) subjects an individual to extrajudicial killing shall, in a civil action, be liable for damages to the individual’s legal representative, or to any person who may be a claimant in an action for wrongful death.⁵⁷

The TVPA extends a civil remedy to U.S. citizen torture victims, while the ATCA provides a remedy for aliens only.

U.S. courts applying the ATCA and TVPA have found that the following acts constitute torture: subjecting detainees to interrogation sessions lasting 14 hours (*Xuncax v. Gramajo*, 886 F. Supp. 162, 170 (D. Mass 1995)); beating with hands (*Tachiona v. Mugabe*, 234 F. Supp. 2d 401, 420-423 (S.D.N.Y. 2002); *Cabiri v. Assasie-Gyimah*, 921 F. Supp. 1189, 1191, 1196 (S.D.N.Y. 1996); *Abebe-Jira v. Negewo*, 72 F.3d 844, 845 (11th Cir. 1996)); threatening

United States Code, prohibits torture committed by public officials under color of law against persons within the public official’s custody or control. . . . The statute applies only to acts of torture committed outside the United States. There is Federal extraterritorial jurisdiction over such acts whenever the perpetrator is a national of the United States or the alleged offender is found within the United States, irrespective of the nationality of the victim or the alleged offender.”

⁵⁷ See S. REP. NO. 102-249 (1991) (stating that the TVPA would “carry out the intent of the Convention Against Torture and Other Cruel, Inhuman or Degrading Treatment or Punishment, which was ratified by the U.S. Senate on October 27, 1990”).

with death (*Abebe-Jira v. Negewo*, 72 F.3d 844, 845 (11th Cir. 1996)); and using techniques to exacerbate pain or injury (*Abebe-Jira v. Negewo*, 72 F.3d 844, 845-6 (11th Cir. 1996)).

**Conclusion: CAT's Prohibition against Torture
as Implemented in U.S. Legislation and Regulation**

U.S. domestic laws prohibiting, or providing a cause of action to victims of, torture are consistent with the standards of CAT. However, these U.S. statutes and regulations are limited to specific contexts – such as, refugee claims, extradition of foreign fugitives, criminalizing acts of torture committed outside the U.S. by U.S. officials, and providing compensation to victims of torture committed by aliens. Accordingly, the U.S. has yet to fulfill its obligation, under CAT, to enact laws which adequately prevent U.S. officials and individuals acting with their consent from subjecting any detainee to torture and which punish such conduct wherever it occurs.

CAT's Prohibition against "Cruel, Inhuman or Degrading Treatment," as
Interpreted by United States Law

As previously noted, the U.S.'s reservation to Article 16 of CAT provides that the United States considers itself bound by Article 16 only insofar as CID treatment is understood to mean "the cruel, unusual and inhumane treatment or punishment prohibited by the Fifth, Eighth and Fourteenth Amendments."

The Senate Foreign Relations Committee report states that this reservation is the outgrowth of concern that "degrading treatment or punishment . . . has been interpreted as potentially including treatment that would probably not be prohibited by the U.S. Constitution" and cites, as an example of what the United States would not find "degrading" under the U.S. Constitution, a holding by the European Commission of Human Rights that the refusal of authorities to give formal recognition to an individual's change of sex might constitute degrading

treatment.⁵⁸ This explanation suggests that the reservation was intended to prevent the importation of foreign social values or mores into U.S. law, rather than any view that international norms of CID treatment are out of step with U.S. law.

In assessing interrogation conduct under Article 16 of CAT, the U.S. should look to international standards defining cruel, inhuman or degrading treatment. If such conduct is prohibited under international law, the U.S. is bound to prevent such conduct unless it would not be prohibited under the Fifth, Eighth and Fourteenth Amendments. The Committees take note that much of the case law under the three Amendments arises in the context of domestic criminal justice proceedings. How this jurisprudence would be applied in a case relating to the detention and interrogation of foreign combatants is not completely clear. For instance, on the one hand some of the special protections provided in the American criminal justice system with respect to interrogations would be of doubtful applicability, particularly considering an asserted state interest in national security. On the other, the absence of a legitimate state interest in punishment might mandate a higher standard of treatment of detainees generally.

Fifth and Fourteenth Amendment Standards

The Constitution's guarantee of due process forbids compulsion to testify, at least for domestic law enforcement purposes, by fear of hurt, torture or exhaustion. *See Adamson v. California*, 332 U.S. 46 (1947) (armed Texas Rangers on several successive nights took defendant from county jail into the woods, whipped him, asked him each time about a confession, interrogated him from approximately 11 p.m. to 3 a.m. and warned him not to speak to anyone about the nightly trips); *Brown v. Mississippi*, 297 U.S. 278 (1936) (confessions

⁵⁸ *See* Report of the Committee on Foreign Relations, Convention Against Torture and Other Cruel, Inhuman, or Degrading Treatment or Punishment, S. EXEC. REP. NO. 30, 101st Cong., 2d Sess. 25 (1990) (statement of Mr. Pell) (citing *Case of X. v. Federal Republic of Germany* (No. 6694/74)).

obtained by mock executions and whippings); *Ashcraft v. Tennessee*, 322 U.S. 143, 154 (1944) (defendant was taken into custody by police officers and for 36 hours thereafter was held incommunicado, without sleep or rest, and interrogated without respite by relays of officers, experienced investigators, and highly trained lawyers); *see also Ashcraft v. Tennessee*, 327 U.S. 274 (1946). However, the presence of unlawful police coercion motivated by “immediate necessity to find the victim and save his life” to extract a confession has been found by one appeals court to be insufficient to exclude a subsequent confession.⁵⁹

Due process also prohibits actions taken under color of law that are “so brutal and offensive to human dignity” that they “shock the conscience.”⁶⁰ The Supreme Court has given content to the phrase “shocks the conscience” by reference to the spectrum of fault standards in tort law. Intentional infliction of injury unjustifiable by any government interest is the sort of official action which could rise to the conscience-shocking level.⁶¹ All applicable sources of law are consistent in prohibiting such extreme conduct.

Eighth Amendment Standards

The Eighth Amendment prohibits “cruel and unusual punishments.”⁶² In the context of law enforcement, U.S. courts have long held that the norms articulated under the Cruel

⁵⁹ *Leon v. Wainwright*, 734 F.2d 770 n.5 (11th Cir. 1984) (kidnapping conviction confirmed based on a confession obtained following a prior coerced confession).

⁶⁰ *Rochin v. California*, 342 U.S. 165, 172 (1952).

⁶¹ *County of Sacramento v. Lewis*, 523 U.S. 833, 848-49 (1998).

⁶² The UCMJ, discussed below, provides that no “cruel or unusual punishment” may be adjudged by any court-martial or inflicted upon any person subject to the UCMJ (10 U.S.C.S. § 855). In general, military courts have applied the Supreme Court’s interpretation of the Eighth Amendment to claims raised under this provision. *See, e.g., United States v. Avila*, 53 M.J. 99, 2000 CAAF LEXIS 569 (C.A.A.F. 2000). Thus, under the UCMJ, POWs and persons who under the law of war are subject to trial for military offences by a military

and Unusual Punishment Clause establish a minimum level of protection, applicable even to pretrial detainees.⁶³

While the Supreme Court initially interpreted the Eighth Amendment as prohibiting only barbaric or torturous punishments, this interpretation was early broadened in two respects: (i) to prevent disproportionate punishments (*Weems v. United States*, 217 U.S. 349 (1910)) and (ii) to address non-physical forms of cruel and unusual punishment (e.g., *Trop v. Dulles*, 356 U.S. 86 (1958) (in case involving denationalization as a punishment for desertion from the United States Army, the Court noted that “evolving standards of decency that mark the progress of a maturing society” should inform interpretation of the Eighth Amendment)). In 1947, the Supreme Court recognized that wanton or unnecessary infliction of pain also constitutes cruel and unusual punishment. *Louisiana ex rel. Francis v. Resweber*, 329 U.S. 459, 463 (1947).

In cases brought by prisoners under the Eighth Amendment alleging that excessive force was used against them by government officials, courts consider both the objective component (whether the wrongdoing was “harmful enough” to implicate the Eighth Amendment) and the subjective component (whether the officials acted with a sufficiently culpable state of mind) of the challenged conduct. *Hudson v. McMillian*, 503 U.S. 1, 8 (1992). In order to establish that the objective component of an Eighth Amendment violation is satisfied, a prisoner need not prove he has sustained significant injury. However, the extent of injury

tribunal are not to be punished in a cruel or unusual manner, within the meaning of the Eighth Amendment.

⁶³ *City of Revere v. Massachusetts Gen. Hosp.*, 463 U.S. 239, 244 (1983). See also *County of Sacramento v. Lewis*, 523 U.S. 833, 849-50 (1998) (citation omitted) (“We held in *City of Revere v. Massachusetts Gen. Hospital* that ‘the due process rights of a [pretrial detainee] are at least as great as the Eighth Amendment protections available to a convicted prisoner’”).

suffered is one factor that may suggest “whether the use of force could plausibly have been thought necessary” in a particular situation, “or instead evinced such wantonness with respect to the unjustified infliction of harm as is tantamount to a knowing willingness that it occur.”⁶⁴ The subjective component involves, in the context of force used by prison officials, “whether force was applied in a good-faith effort to maintain or restore discipline, or maliciously and sadistically for the very purpose of causing harm.”⁶⁵

Enforcement of CAT under U.S. Law

18 U.S.C. §§ 2340 – 2340B

As stated above, the United States’ attempt to comply with its obligation under CAT to criminalize torture is codified in 18 U.S.C. § 2340A. Section 2340A criminalizes conduct by a U.S. national or a foreign national present in the U.S. who, acting under color of law, commits or attempts to commit torture outside the United States. The statute is exclusively criminal and may not be construed as creating any right enforceable in a civil proceeding. See 18 U.S.C. § 2340B. Section 2340A generally applies to acts committed by U.S. nationals overseas (everywhere *except* “all areas under the jurisdiction of the United States, including any of the places described in sections 5 and 7 of this title and Section 46501(2) of Title 49.”) When the Section was enacted the reach of the cross-referenced provisions, notably 18 U.S.C. § 7, was uncertain.⁶⁶ However, Section 7 was broadened in the USA PATRIOT Act to clarify jurisdiction

⁶⁴ *Hudson v. McMillian*, 503 U.S. 1, 7 (1992) (quoting *Whitley v. Albers*, 475 U.S. 312, 321 (1986)).

⁶⁵ *Whitley v. Albers*, 475 U.S. 312, 320-21 (1986) (quoting *Johnson v. Glick*, 481 F.2d 1028, 1033 (2d Cir. 1973)).

⁶⁶ Compare *U.S. v. Gatlin*, 216 F.3d 207 (2d Cir 2000) with *U.S. v. Corey*, 232 F.3d 1166 (9th Cir 2000). However, the question was substantially mooted for most purposes by the passage of the Military Extraterritorial Jurisdiction Act of 2000, PUB. L. 106-503, 112 STAT. 2488,

over crimes committed against U.S. citizens on U.S. property abroad by extending U.S. criminal jurisdiction over certain crimes committed at its foreign diplomatic, military and other facilities, and by cross-reference excluded those places from the reach of Section 2340A. The resulting drastic limitation of jurisdiction under 18 U.S.C. § 2340A appears unintended. We recommend that Congress amend Section 2340A to assure that it applies to U.S. government premises abroad without prejudice to the expansion of U.S. criminal jurisdiction under other statutes.

The U.S. did not enact a specific criminal statute outlawing torture within the United States, out of deference to federal-state relations and because it determined that existing federal and state criminal law was sufficient to cover any domestic act that would qualify as torture under CAT.⁶⁷ It is submitted that the inapplicability of state law to U.S. facilities abroad and the lack of other federal criminal law comparable to Section 2340A leaves a serious vacuum in carrying out the obligations of the U.S. under CAT.

Unfortunately the U.S. has never enforced 18 U.S.C. § 2340A, and has thereby fallen far short of its obligations under international law and its professed ideals. The United States has failed to utilize 18 U.S.C. § 2340A to prosecute either U.S. agents suspected of committing torture outside the jurisdiction of the U.S. or foreign torturers living within the United States. Indeed, Amnesty International reported in 2002 that in the eight years following the enactment of 18 U.S.C. § 2340 and § 2340A, not a single case had been brought under that section.⁶⁸

which subjects persons accompanying the armed forces abroad to U.S. civilian criminal jurisdiction, even if outside the "special maritime and territorial jurisdiction."

⁶⁷ See U.S. Dept. of State, Initial Report of the United States of America to the U.N. Committee against Torture, U.N. Doc. CAT/C/28/Add.5 (1999), at para. 178.

⁶⁸ *Amnesty International Report Charges U.S. is "Safe Haven" for Torturers Fleeing Justice; Eight Years On, U.S. Has Failed to Prosecute Single Individual for Torture*, Amnesty

Uniform Code of Military Justice

The UCMJ may be used to prosecute in courts-martial certain acts of ill-treatment carried out, whether within the United States or overseas, by American military personnel and possibly certain civilians accompanying such personnel. This federal statute is essentially a complete set of criminal laws that includes both crimes that are normally part of a criminal code as well as uniquely military and wartime offenses.

As a jurisdictional matter, the UCMJ applies worldwide (10 U.S.C. § 805), and persons subject to the UCMJ include any U.S. service member (10 U.S.C. § 802) as well as certain civilians “[i]n time of war ... serving with or accompanying an armed force in the field” (10 U.S.C. § 802(a)(10)) and POWs (10 U.S.C. § 802(a)(9)).⁶⁹ Because courts-martial have jurisdiction to try “any person who by the law of war is subject to trial by a military tribunal” for any offense against the laws of war (10 U.S.C. § 818), the UCMJ would seem to apply also to “unlawful combatants” deemed by the Administration not to qualify for POW status under Geneva III.

The broad statutory application of the UCMJ to civilians associated in various ways with the armed forces has been judicially limited in deference to the requirements of Article III, Section II, of the Constitution and the Fifth and Sixth Amendments protecting the right to trial by jury. As so limited, the UCMJ does not apply to civilians who have no military status in peacetime, even if they are accompanying United States forces overseas as employees or dependents. Although courts’ interpretations of the terms “serving”, “accompanying” and “in

International Press Release (2002) (available at <http://www.amnestyusa.org/news/2002/usa04102002.html>). See also William J. Aceves UNITED STATES OF AMERICA: A SAFE HAVEN FOR TORTURERS (Amnesty International USA Publications 2002), at 50.

⁶⁹ The UCMJ does not define the term POW. Thus it is uncertain whether POW in the UCMJ has the same meaning as in Geneva III.

the field” suggest a broad application, the “time of war” requirement is construed narrowly when applied to civilians.⁷⁰ As recently as 1998, the Court of Appeals for the Armed Forces⁷¹ analyzed the propriety of the application of the UCMJ to civilians and stated:

As a matter of constitutional law, the Supreme Court has held that Congress may not extend court-martial jurisdiction to cover civilians who have no military status in peacetime, even if they are accompanying United States forces overseas as employees or dependents.

Willenbring v. Neurauter, 48 M.J. 152, 157, 1998 CAAF LEXIS 43 (C.A.A.F. 1998). The line of cases in this area generally focuses on the application of the UCMJ to civilian contractors and civilian dependents of service members. *See, e.g., Robb v. United States*, 456 F.2d 768 (Ct. Cl. 1972) (civilian engineer employed by U.S. Navy in Vietnam was not subject to UCMJ); *Reid v. Covert*, 354 U.S. 1 (1957) (no jurisdiction over civilian dependents of service members stationed overseas in peacetime for capital offenses). No cases directly address whether CIA operatives conducting para-military operations with the regular armed forces or interrogations within a military base are considered civilians for purposes of UCMJ application. In *Reid v. Covert*, the Supreme Court stated, “[e]ven if it were possible, we need not attempt here to precisely define the boundary between ‘civilians’ and members of the ‘land and naval Forces.’ We recognize that

⁷⁰ *United States v. Averette*, 19 U.S.C.M.A. 363, 365-66, 41 C.M.R. 363, 365-66 (1970) (the phrase “in time of war” is limited to “a war formally declared by Congress”; even though the Vietnam conflict “qualified as a war as that word is generally used and understood[,] ... such a recognition should not serve as a shortcut for a formal declaration of war, at least in the sensitive area of subjecting civilians to military jurisdiction”). *Cf. United States v. Anderson*, 17 U.S.C.M.A. 588, 589, 38 C.M.R. 386, 387 (1968) (United States’ involvement in Vietnam conflict “constitutes a ‘time of war’ . . . within the meaning of” Article 43(a) of the UCMJ, which provides that there is no statute of limitations over certain offenses committed “in time of war”).

⁷¹ The Court of Appeals for the Armed Forces (formerly the Court of Military Appeals) is a civilian Article I court hearing appeals from the intermediate appellate courts for each of the Army, Navy (and Marines) and Air Force, subject to possible appeal to the United States Supreme Court.

there might be circumstances where a person could be ‘in’ the armed services . . . even though he had not formally been inducted into the military or did not wear a uniform.” See 354 U.S. at 22.⁷² In any event, where a CIA operative is a detached service member who has not been formally discharged from military service (as is often the case in practice), the UCMJ would generally apply to such person in time of war or peace.

The UCMJ provides the strongest substantive basis for potential prosecution of torture or CID treatment in federal criminal law, specifically outlawing cruel or unusual punishment, torture under 18 U.S.C. § 2340 and a variety of related offenses. Article 55 of the UCMJ provides that:

Punishment by flogging, or by branding, marking, or tattooing on the body, or any other cruel or unusual punishment, may not be adjudged by any court-martial or inflicted upon any person subject to this chapter. The use of irons, single or double, except for the purpose of safe custody, is prohibited.

10 U.S.C. § 855.⁷³ Article 55 is unique in its specific definition of “cruel or unusual punishment” as an offense.⁷⁴ While most military courts have followed the Supreme Court’s analytical framework of protections under the Eighth Amendment as they pertain to cruel and

⁷² As previously noted, the Military Extraterritorial Jurisdiction Act of 2000, *see supra* note 66, eliminated any gap in jurisdiction resulting from *Reid v. Covert* by conferring jurisdiction on federal courts over civilians accompanying the armed forces abroad.

⁷³ The protections of Article 55 apply to “any person subject to” the UCMJ. And as stated previously, the UCMJ would seem to apply to unlawful combatants under 10 U.S.C. § 818.

⁷⁴ The Articles of War preceding the UCMJ prohibited “cruel and unusual punishment,” but the phrase was changed to “cruel *or* unusual punishment” in Article 55 (emphasis added). See Articles of War 41, Manual for Courts-Martial, U.S. Army, 1929 at 212, and 1949 at 284. The legislative history of Article 55 provides no rationale why the word “and” was changed to “or.” *United States v. White*, 54 M.J. 469, 2001 CAAF LEXIS 497 (C.A.A.F. 2001).

unusual punishment,⁷⁵ several military courts have found that Article 55 provides greater protections than those given under the Eighth Amendment.⁷⁶ It is notable that Article 55 applies at least the equivalent of the protection afforded by the Eighth Amendment even if the victim is not otherwise entitled to constitutional rights (e.g., a non-citizen apprehended and detained outside the U.S. and arguably not entitled to such rights).⁷⁷

Moreover, the UCMJ effectively provides a basis for the prosecution of military personnel in courts-martial for the offense of torture in violation of 18 U.S.C. § 2340.

Article 134 of the UCMJ (10 U.S.C. § 934) provides:

Though not specifically mentioned in this chapter, all disorders and neglects to the prejudice of good order and discipline in the armed forces, all conduct of a nature to bring discredit upon the armed forces, and crimes and offenses not capital, of which persons subject to this chapter may be guilty, shall be taken cognizance of by a general, special, or summary court-martial, according to the nature and degree of the offense, and shall be punished at the discretion of that court.

Article 134 makes punishable acts in three categories of offenses not specifically covered in any other article of the UCMJ: Clause 1 offenses involving disorders and neglect to the prejudice of good order and discipline; Clause 2 offenses involving conduct of a nature to bring discredit upon the armed forces; and Clause 3 offenses entailing non-capital crimes or offenses that violate Federal law.

⁷⁵ See *United States v. Kinsch*, 54 M.J. 641, 2000 CCA LEXIS 237 (A.C.C.A. 2000). See also Section I(C)(3)(b) of this Report for a fuller discussion of the Eighth Amendment prohibition of cruel and unusual treatment and punishment.

⁷⁶ See *United States v. Wappler*, 2 C.M.A. 393, 9 C.M.R. 23, 1953 CMA LEXIS 897 (C.M.A. 1953); *White*, 54 M.J. at 473; *United States v. Avila*, 53 M.J. 99, 2000 CAAF LEXIS 569 (C.A.A.F. 2000).

⁷⁷ Compare the federal criminal civil rights statutes, 18 U.S.C. §§ 241 and 242, and the civil statute 42 U.S.C. § 1983, all of which apply only where the victim is entitled to constitutional rights.

In order to successfully charge an individual under Clauses 1 and 2 of this Article, the government must show: (i) that the accused did or failed to do certain acts; and (ii) that, under the circumstances, the accused's conduct was to the prejudice of good order and discipline in the armed forces or was of a nature to bring discredit upon the armed forces.⁷⁸ Under Clause 1, the acts must be directly prejudicial to good order and discipline, rather than remotely so. Under Clause 2, discredit is interpreted to mean "injure the reputation of," and encompasses conduct that brings the service "into disrepute or which tends to lower it in public esteem."⁷⁹ With respect to Clause 3 offenses, as a general rule, any offense created by Federal statute may be prosecuted as an Article 134 offense. *United States v. Perkins*, 47 C.M.R. 259 (Ct. of Mil. Rev. 1973).⁸⁰

Thus, a service member whose conduct is alleged to violate 18 U.S.C. § 2340, the federal enactment of CAT, could be prosecuted under Article 134 of the UCMJ, as a Clause 3 violation. Moreover, multiple counts alleging Article 134 violations also could be brought in such a situation, as such conduct could be construed as prejudicial to good order and discipline and/or of a nature to bring discredit upon the armed forces. *Perkins*, 47 C.M.R. at 263-264.

⁷⁸ Manual for Courts-Martial, United States, (1995 edition) (the "Manual"), Paragraph 60.b (1-2). The Manual is issued by the President as a regulation under the authority granted by Congress under Article 3 of the UCMJ.

⁷⁹ Manual, Paragraph 60.c (3).

⁸⁰ According to the Manual, however, the doctrine of preemption "prohibits application of Article 134 to conduct covered by Articles 80 through 132. For example, larceny is covered in Article 121, and if an element of that offense is lacking—for example, intent—there can be no larceny or larceny type offense, either under Article 121 or, because of preemption, under Article 134." Manual, Paragraph 60.c (5)(a). In effect, Article 134 may not be employed to salvage a charge where the charge could not be sustained under the substantive offense provisions of the UCMJ or Federal statute. Accordingly, conduct which violated Article 55 discussed above or any other substantive provision of the UCMJ could not be charged under Article 134. These remain alternative, not cumulative provisions.

Finally, criminal charges for torture or CID conduct could be brought under a variety of other provisions⁸¹ including “cruelty.”⁸² The last of these offenses is generally intended to be applied to mistreatment of U.S. service members by their superiors, but by its terms it is not so limited and has been applied to intentional mistreatment of detainees.⁸³ And in instances where specific orders are in place regarding the treatment of detainees, as is recommended in this Report, failure to obey such orders is punishable under 10 U.S.C. § 892. A number of service members in Iraq are or have been investigated or tried for assaulting detainees,

⁸¹ For example, murder (10 U.S.C. § 918), manslaughter (10 U.S.C. § 919), dereliction of duty (10 U.S.C. § 892).

For purposes of this Report, we assume that U.S. military interrogations of detainees are conducted for intelligence gathering purposes and not with an investigatory intent to elicit incriminating responses in anticipation of criminal prosecution. However, should the focus of the interrogation shift from an intelligence to a law enforcement nature, Miranda warnings under Article 31 of the UCMJ (10 U.S.C. § 831) would be required. The failure to give such warnings is a criminal offense under Article 98 of the UCMJ (10 U.S.C. § 898).

⁸² See Article 93 of the UCMJ (10 U.S.C. § 893). Two Marines face charges for assault, cruelty and dereliction of duty involving the treatment and death of an Iraqi prisoner. See Associated Press Newswires, *Two Marines Face Trial After Iraqi Dies*, Apr. 14, 2004; Tony Perry, *Iraqi Prisoner Died After Marine Grabbed His Throat, Officials Say*, L.A. TIMES, Oct. 22, 2003, at B06. It is not believed that the incident involved interrogation, but it is notable that such alleged offenses involved Marine infantry reservists who had not been trained in the treatment of prisoners (apart from one with relevant peacetime background) and are reported to have been given only a brief orientation before being assigned to this duty. As advocated elsewhere in this Report, proper training of U.S. military and intelligence personnel is essential to achieve compliance with the U.S.’s obligations under CAT.

⁸³ Article 93 prohibits a person subject to the jurisdiction of the UCMJ from committing acts of “cruelty toward, or oppression or maltreatment of, any person subject to his orders.” The phrase “any person subject to his orders” in Article 93 is defined as: “not only those persons under the direct or immediate command of the accused but extends to all persons, subject to the...[UCMJ] or not, who by reason of some duty are required to obey the lawful orders of the accused, regardless whether the accused is in the direct chain of command over the person.” Manual for Courts-Martial, United States, (1995 edition), Part IV, P 17c(1).

under the assault provision of the UCMJ (Article 128), and in at least one case the alleged assault occurred in the context of an interrogation.⁸⁴

The UCMJ is thus the substantively most extensive body of federal criminal law relating to the interrogation of detainees by U.S. military personnel and, in time of war, its reach could possibly extend to civilians such as CIA agents accompanying such personnel. It prohibits such persons from subjecting detainees to torture and “cruel or unusual punishment” within or without the United States and regardless of the applicability of constitutional rights.

Summary

CAT’s prohibition against torture is absolute. By ratifying CAT, the United States has accepted that the prohibition of torture is non-derogable. Moreover, by implementing prohibitions against torture in immigration, extradition, criminal and civil tort law contexts, the U.S. has given CAT’s prohibition against torture the force of U.S. law. Furthermore, by stipulating that CAT’s prohibition on CID treatment or punishment means the cruel and unusual treatment or punishment prohibited by the U.S. Constitution, the U.S. has made relevant the case law providing that detainees cannot be subjected to interrogation techniques: that force them to answer law enforcement questions by “fear of hurt, torture or exhaustion,” *Adamson v. California, supra*; that are “brutal and offensive to human dignity,” *Rochin v. California, supra*; that fall below the “evolving standards of decency that mark the progress of a maturing society,”

⁸⁴ An officer in Iraq was charged under Article 28 (10 U.S.C. § 928) for firing his pistol near an Iraqi detainee’s head in the course of an interrogation in order to elicit details about a planned ambush or assassination. Thomas E. Ricks, *Army Accuses Officer In Iraq Of Firing Pistol Near Prisoner*, WASH. POST, Oct. 30, 2003, at A14. The officer faced a possible court-martial and up to eight years imprisonment. Following a UCMJ Article 32 hearing (which is akin to a grand jury or preliminary hearing), the division’s commanding general ordered that the officer be fined and allowed to retire. See *U.S. Officer Fined for Harsh Interrogation Tactics* (Dec. 13, 2003) (available at <http://www.cnn.com/2003/US/12/12/sprj.nirq.west.ruling>).

Trop v. Dulles, supra; or which deliberately inflict force or pain (in the context of restoring prison order or safety), *Hudson v. McMillian, supra*. However, U.S. enforcement of CAT in our domestic criminal law – particularly with respect to acts of torture or CID treatment by U.S. civilians or by U.S. officials in extra-territorial areas under U.S. jurisdiction – has been incomplete. We urge the U.S. to fill in the gaps in preventing and punishing torture and CID treatment left by 18 U.S.C. § 2340A and to fully utilize the UCMJ to fulfill its obligations under CAT.

THE GENEVA CONVENTIONS

The four Geneva Conventions of 1949 are the core of the international law of armed conflict applicable to the treatment of detainees, albeit not the complete body of applicable law. The applicability of the Geneva Conventions to persons captured by the United States in connection with the War In Afghanistan and the ongoing conflict in Afghanistan, however, is highly controversial. The most hotly contested issue is whether those Al Qaeda and Taliban detainees who were captured before the creation of the Karzai government are entitled to POW status under Geneva Convention III Relative to the Treatment of Prisoners of War (“Geneva III”). This issue is of particular significance because Geneva III flatly prohibits “any form of coercion” of POWs in interrogation – the most protective standard of treatment found in international law. Likewise, Geneva Convention IV Relative to the Protection of Civilian Persons in Time of War (“Geneva IV”) protects “civilian” detainees who qualify as “protected persons” from “coercion.”⁸⁵ We also should note that the issues regarding Geneva III and Geneva IV are affected by whether the person was detained either before or after the Karzai

⁸⁵ See Section II(C) for a discussion of who qualifies as a “protected person” under Geneva IV.

government was established. Before the Karzai government, the U.S. was engaged in an international armed conflict with Afghanistan, which was governed by the Taliban (albeit the U.S. did not recognize that government). After the establishment of the Karzai government, the conflict in Afghanistan became an internal one – as the U.S. and other international organizations were present in Afghanistan with the consent of the Karzai government to assist in maintaining order. Geneva III and Geneva IV apply only in situations of international armed conflict and, therefore, ceased to apply once the Afghan conflict became an internal one. *See* Geneva IV, Art. 6.

In this section, we will examine the Administration’s position that Al Qaeda and Taliban detainees are not POWs under Geneva III and some critiques of the Administration’s position. We submit that, regardless of whether a detainee enjoys status as a POW or civilian protected person under the Geneva Conventions, the Conventions nevertheless are relevant to the interrogation of detainees in the following respects:

First, the requirements of humane treatment embodied in Common Article 3 of the Geneva Conventions and Article 75 of Additional Protocol I protect all detainees captured in situations of international or internal armed conflict, regardless of “legal” status.⁸⁶ Of course, all

⁸⁶ “Common Article 3” provides that detainees “shall in all circumstances be treated humanely” and prohibits the following acts “at any time and in any place whatsoever”: “violence to life and person, in particular murder of all kinds, mutilation, cruel treatment and torture;” and “outrages upon personal dignity, in particular humiliating or degrading treatment.” Common Article 3 also provides that the “wounded and sick shall be collected and cared for.”

Although neither the United States nor Afghanistan is a party to Additional Protocol I, it is generally acknowledged that relevant sections of Protocol I constitute either binding customary international law or good practice, in particular the minimum safeguards guaranteed by Article 75(2). *See* Michael J. Matheson, *Remarks on the United States Position on the Relation of Customary International Law to the 1977 Protocols Additional to the 1949 Geneva Conventions*, reprinted in *The Sixth Annual American Red Cross-Washington College of Law Conference on International Humanitarian Law: A Workshop on*

detainees – including those captured outside of Afghan territory or in connection with the “War on Terror” – are entitled to the protection provided by human rights law, including CAT, the ICCPR and customary international law.

Second, notwithstanding its position on the POW status of Taliban and Al Qaeda detainees, the Administration has undertaken that it will treat all detainees in a manner consistent with the principles of Geneva III. Accordingly, the interrogation techniques reportedly being used on detainees at Bagram and other U.S. detention facilities should be considered in light of the text and spirit of the Geneva Conventions.

Third, if there is doubt as to whether a detainee meets Geneva III criteria for POW status, that detainee is entitled to interim POW status until a “competent tribunal” determines his or her legal status. Because the U.S. government has not convened “competent tribunals” to

Customary International Law and the 1977 Protocols Additional to the 1949 Geneva Conventions, 2 AM. U. J. INT’L L. & POL’Y 415, 425-6 (1987).

Article 75 provides that “persons who are in the power of a Party to the conflict and who do not benefit from more favourable treatment under the Conventions” “shall be treated humanely in all circumstances” and that each state Party “shall respect the person, honour, convictions and religious practices of all such persons.” Paragraph 2 of Article 75 prohibits, “at any time and in any place whatsoever, whether committed by civilian or military agents”: “violence to the life, health, or physical or mental well-being of persons, in particular . . . torture of all kinds, whether physical or mental,” “corporal punishment,” and “mutilation”; “outrages upon personal dignity, in particular humiliating and degrading treatment . . . and any form of indecent assault”; and “threats to commit any of the foregoing acts.”

The U.S. rejection of Additional Protocol I was explained in a presidential note to the Senate in the following terms: “Protocol I . . . would grant combatant status to irregular forces even if they do not satisfy the traditional requirements to distinguish themselves from the civilian population and otherwise comply with the laws of war. This would endanger civilians among whom terrorists and other irregulars attempt to conceal themselves. These problems are so fundamental in character that they cannot be remedied through reservations. . . .” *See* 1977 U.S.T. LEXIS 465.

determine the status of any detainees, all detainees for whom POW status is in doubt are entitled to interim POW status.⁸⁷

Finally, even accepting the interpretation that the Third and Fourth Geneva Conventions contain gaps leaving certain detainees captured in the War in Afghanistan (*i.e.*, citizens of co-belligerents and neutrals) without POW or “protected person” civilian status, the Geneva Conventions are supplemented by human rights law and customary international legal norms which have the force of law in the United States. For example, even where a detainee may not be entitled to a hearing under Geneva III, he is entitled to a hearing to determine the justification for his detention under Article 9 of the ICCPR. Many detainees may not be combatants at all and may be simply innocent bystanders mistakenly detained or wrongfully turned over to the U.S. military by the Northern Alliance.⁸⁸ They deserve prompt hearings in which they are given an opportunity to establish their non-combatant status.

⁸⁷ See Geneva III, Art. 5; *see also* U.S. Dept. of Army, Field Manual 27-10, “Law of Land Warfare”, Art. 71 (1956); U.S. Dept. of Army, REGULATION 190-8 Military Police, “Enemy Prisoners of War, Retained Personnel, Civilian Internees and Other Detainees,” § 1-5 (a)(2) (1997).

⁸⁸ *See, e.g.*, Dep’t of Defense, Secretary Rumsfeld Media Availability en route to Camp X-Ray (Jan. 27, 2002) (available at http://www.defenselink.mil/news/Jan2002/t01282002_t0127sd2.html) (“Sometimes when you capture a big, large group there will be someone who just happened to be in there that didn’t belong in there.”) (remarks of Respondent, Secretary of Defense Donald H. Rumsfeld); Carlotta Gall, *Freed Afghan, 15, Recalls a Year at Guantánamo*, N.Y. TIMES, Feb. 11, 2004, at A03 (quoting released teenager claiming to have been captured by non-U.S. forces and handed over to the Americans while looking for a job); Jan McGirk, *Pakistani Writes of His U.S. Ordeal*, BOSTON GLOBE, Nov. 17, 2002, at A30 (“Pakistan intelligence sources said Northern Alliance commanders could receive \$5000 for each Taliban prisoner and \$20,000 for a[n] [al] Qaeda fighter. As a result, bounty hunters rounded up any men who came near the battlegrounds and forced them to confess.”).

Application of the Geneva Conventions to the Afghan Conflict Generally

Both the U.S. and Afghanistan are parties to the Geneva Conventions. Article 2 common to all four Conventions provides that the Conventions “apply to all cases of declared war or of any other armed conflict” between two or more parties to the Conventions so long as a state of war is recognized by a party to the conflict. The Conventions also apply to all cases of partial or total occupation of the territory of a signatory, even if the occupation meets with no armed resistance. *See* Geneva Conventions, Art. 2. Signatories to the Conventions are bound by its terms regardless of whether an additional party to the conflict is a signatory. *Id.* The Administration’s position is that the Geneva Conventions apply to the War in Afghanistan.⁸⁹

Geneva III

Relevant Legal Standards

Under Geneva III, combatants are entitled to POW status if they are members of the armed forces (other than medical personnel and chaplains). The specific requirements for combatant/POW status are set forth in Article 4 of Geneva III⁹⁰ and Articles 43 and 44 of Additional Protocol I.⁹¹

⁸⁹ *See, e.g.,* Sean D. Murphy, *Contemporary Practice of the United States Relating to International Law*, 96 AM. J. INT’L L. 461, 476-77 (2002).

⁹⁰ Article 4-A of Geneva III provides, in part:

Prisoners of war, in the sense of the present Convention, are persons belonging to one of the following categories, who have fallen into the power of the enemy:

Members of the armed forces of a Party to the conflict as well as members of militias or volunteer corps forming part of such armed forces.

Members of other militias and members of other volunteer corps, including those of organized resistance movements, belonging to a Party to the conflict and operating in or outside their own territory, even if this territory is occupied, provided that such militias or

If there is any doubt as to whether captured persons meet Article 4's criteria for POW status, such persons are entitled to interim POW status until a "competent tribunal" determines their legal status.⁹²

volunteer corps, including such organized resistance movements, fulfill the following conditions:

- (a) of being commanded by a person responsible for his subordinates;
- (b) that of having a fixed distinctive sign recognizable at a distance;
- (c) that of carrying arms openly;
- (d) that of conducting their operations in accordance with the laws and customs of war.

Members of regular armed forces who profess allegiance to a government or an authority not recognized by the Detaining Power. . . .

⁹¹ Article 43 of Additional Protocol I provides: "The armed forces of a Party to a conflict consist of all organized armed forces, groups and units which are under a command responsible to that Party for the conduct or its subordinates, even if that Party is represented by a government or an authority not recognized by an adverse Party. Such armed forces shall be subject to an internal disciplinary system which, inter alia, shall enforce compliance with the rules of international law applicable in armed conflict."

⁹² See Geneva III, Art. 5; see also, U.S. Dept. of Army, Field Manual 27-10, "Law of Land Warfare", Art. 71 (1956); U.S. Dept. of Army, REGULATION 190-8 Military Police, "Enemy Prisoners of War, Retained Personnel, Civilian Internees and Other Detainees," § 1-5 (a)(2) (1997). Under U.S. military regulations, a "competent tribunal" pursuant to Article 5 of Geneva III consists of three commissioned officers. The regulations also require that persons whose status is to be determined be advised of their rights; be permitted to attend all open sessions, call witnesses and question witnesses called by the tribunal; be permitted (but not compelled) to testify or otherwise address the tribunal; and be provided with an interpreter. The regulations provide for the tribunal's determination of a detainee's status in closed session by a majority vote and require a preponderance of the evidence to support the tribunal's finding. See Erin Chlopak, *Dealing with the Detainees at Guantánamo Bay: Humanitarian and Human Rights Obligations Under the Geneva Conventions*, HUM RTS. BR. (Spring 2002), at 6, 8.

Geneva III mandates that POWs be treated humanely at all times. This includes freedom from physical and mental torture, acts of violence, intimidation and insult, and exposure to public humiliation.⁹³ Pursuant to Article 14, POWs also “are entitled in all circumstances to respect for their persons and their honour . . . [and] shall retain the full civil capacity which they enjoyed at the time of their capture.”

With respect to interrogation, in particular, Article 17 of Geneva III provides: “No physical or mental torture, nor any other form of coercion, may be inflicted on prisoners of war to secure from them information of any kind whatever. Prisoners of war who refuse to

It should be noted that the “competent tribunal” outlined in ARMY REG. 190-8, § 1-6 is a quick, administrative process that is highly dependent upon the availability of witnesses during ongoing combat and support operations. Unsworn statements may be presented as evidence, and a record of the proceedings is developed. Although the tribunal may or may not include military lawyers such as members of the Staff Judge Advocate General (“JAG”), JAG lawyers will subsequently review the record. The record may also be the basis for any further proceedings for war crimes or for any other penalty.

Fundamentally, the tribunal determines only status and does not adjudicate liability. Tribunals are required under Geneva III only when status of the detainee is in doubt. When, for example, ten thousand uniformed members of a regular enemy infantry division surrender as a body, there is no need for a tribunal. When, however, non-uniformed, but possibly military, personnel mix with refugees, that is a classic situation for such tribunals.

⁹³ Specifically, Article 13 of Geneva III provides:

Prisoners of war must at all times be humanely treated. Any unlawful act or omission by the Detaining Power causing death or seriously endangering the health of a prisoner of war in its custody is prohibited, and will be regarded as a serious breach of the present Convention. In particular, no prisoner of war may be subjected to physical mutilation or to medical or scientific experiments of any kind which are not justified by the medical, dental or hospital treatment of the prisoner concerned and carried out in his interest.

Likewise, prisoners of war must at all times be protected, particularly against acts of violence or intimidation and against insults and public curiosity.

answer may not be threatened, insulted, or exposed to any unpleasant or disadvantageous treatment of any kind.” Under Article 17, POWs are only obligated to provide their name, rank, date of birth, and army, personal or serial identification number or equivalent information. Geneva III does not, however, prohibit non-coercive interrogation of POWs. POWs may be interrogated, but they are not obliged to respond to such interrogation, nor may they be threatened, coerced into responding or punished for failing to respond. The Geneva Conventions also do not “preclude classic plea bargaining” – *i.e.*, the offer of leniency or other incentives in return for cooperation.⁹⁴

Thus, to the extent detainees from the War in Afghanistan are considered POWs or to the extent their POW status is in “doubt” pending the determination of status by a competent tribunal, interrogation tactics which rise to the level of “coercion” are prohibited by Geneva III.

The United States’ Position

In sharp contrast with past conflicts (such as Vietnam and Korea) in which it was U.S. policy to presume that military prisoners were entitled to POW status regardless of the possible nonqualification of their forces under Geneva III, from the very outset of the War in Afghanistan, United States officials labeled captured Al Qaeda and Taliban prisoners “unlawful combatants,” and stated that the Geneva Conventions were, therefore, entirely inapplicable to their treatment.⁹⁵ The United States reasoned that Al Qaeda was not entitled to the protections of the Geneva Conventions because: (1) Geneva III could not apply to members of a nonstate organization, such as Al Qaeda, (2) the conflict was not an internal conflict such that Al Qaeda

⁹⁴ Manooher Mofidi and Amy E. Eckert, “Unlawful Combatants” or “Prisoners of War”: *The Law and Politics of Labels*, 36 CORNELL INT’L L.J. 59, 89 (2003).

⁹⁵ Murphy, *supra* note 89, at 476-77.

members could benefit from the protection of Common Article 3, and (3) in any event, Al Qaeda members failed to meet the requirements set forth in Article 4(A)(2) of Geneva III.⁹⁶ The United States argued further that, since Afghanistan was not a functioning state during the conflict and the Taliban was not recognized as a legitimate government, Geneva III could not apply to the Taliban.⁹⁷

After vigorous criticism was leveled against these arguments, Secretary of State Colin Powell requested that the Administration reconsider its position.⁹⁸ On February 7, 2002, in response to Powell's comments, the Administration partially reversed its initial position. Although the Administration continues to argue that the Geneva Conventions are inapplicable to Al Qaeda captives, President Bush announced that Geneva III was applicable to the Taliban because both the U.S. and Afghanistan were signatories to the Convention and the parties had been involved in an armed conflict. However, President Bush further argued that because the Taliban had violated the laws of war and associated closely with Al Qaeda, "[u]nder the terms of the Geneva Convention ... the Taliban detainees do not qualify as POWs."⁹⁹ The decision in

⁹⁶ *Id.*

⁹⁷ *Id.*

⁹⁸ Powell asked that the Administration recognize that the Geneva Conventions apply to the conflict between the U.S. and Taliban regime and that the Administration convene a "competent tribunal" to determine the status of the prisoners pursuant to Article 5 of Geneva III. See Katharine Q. Seelye, *A Nation Challenged: The Prisoners; Powell Asks Bush to Review Stand on War Captives*, N.Y. TIMES, Jan. 27, 2002, at A01; William Safire, Editorial, *Colin Powell Dissents*, N.Y. TIMES, Jan. 28, 2002, at A15.

⁹⁹ See *supra* note 18.

U.S. Secretary of Defense Donald Rumsfeld, responding to a request for clarification, referred to Article 4(a)(2) of Geneva III to explain why the Taliban could not qualify for POW status: "The Taliban [like Al Qaeda] also did not wear uniforms, they did not have insignia, they did not carry their weapons openly, and they were tied tightly at the waist to Al

United States v. Lindh, 212 F. Supp. 2d 541 (E.D. Va. 2002), which specifically addresses the issue of whether the Taliban are entitled to POW status under Geneva III, sheds further light on the U.S. position.¹⁰⁰

Critiques of the United States' Position
International humanitarian and human rights organizations and legal bodies,

including the International Committee of the Red Cross ("ICRC"),¹⁰¹ the Inter-American Court

Qaeda. They behaved like them, they worked with them, they functioned with them, they cooperated with respect to communications, they cooperated with respect to supplies and ammunition." Secretary of Defense Donald H. Rumsfeld, Remarks on Ferry from Air Terminal to Main Base, Guantánamo Bay, Cuba (Jan. 27, 2002) (transcript available at http://www.defenselink.mil/transcripts/2002/t01282002_t0127sd2.html).

¹⁰⁰ Applying the four-part test from Article 4(a)(2) of Geneva III to the determination, the *Lindh* court found that the Taliban had an insufficient internal system of military command or discipline, that the "Taliban typically wore no distinctive sign that could be recognized by opposing combatants," and that the "Taliban regularly targeted civilian populations in clear contravention of the laws and customs of war." *Lindh*, 212 F. Supp. 2d at 558. Implicitly the *Lindh* Court held that the four conditions listed in Geneva III, Article 4(a)(2) also apply to "regular armed forces." *Id.* at 557. In concluding that the Taliban were not regular armed forces, the *Lindh* court stated "[i]t would indeed be absurd for members of a so-called 'regular armed force' to enjoy lawful combatant immunity even though the force had no established command structure and its members wore no recognizable symbol or insignia, concealed their weapons, and did not abide by the customary laws of war. Simply put, the label 'regular armed force' cannot be used to mask unlawful combatant status." *Id.*, at n.35.

See also Int'l Comm. of the Red Cross, *Commentaries to Article 4(a)(1) Convention (III) relative to the Treatment of Prisoners of War, Geneva, 12 August 1949*, ICRC Database on Int'l Humanitarian Law (available at <http://www.icrc.org/ihl.nsf/b466ed681ddfcfd241256739003e6368/3ca76fa4dae5b32ec12563ed00425040?OpenDocument>) ("It is the duty of each State to take steps so that members of its armed forces can be immediately recognized as such and to see to it that they are easily distinguishable from members of the enemy armed forces or from civilians."). See also, generally, INGRID DETTER, *THE LAW OF WAR* (Cambridge Univ. Press, 2nd ed., 2000), at 136; Christopher Greenwood, *International Law and the War Against Terrorism*, 78 INTERNATIONAL AFFAIRS 301, 316 (2002); Ruth Wedgwood, *Al Qaeda, Terrorism, and Military Commissions*, 96 AM. J. INT'L L. 328, 335 (2002).

¹⁰¹ ICRC, *Geneva Convention on Prisoners of War* (Feb. 9, 2002) (available at [http://www.icrc.org/Web/Eng/siteeng\(\).nsf/iwpList454/26D99836025EA80Dc1256B6600610C90](http://www.icrc.org/Web/Eng/siteeng().nsf/iwpList454/26D99836025EA80Dc1256B6600610C90)) ("International Humanitarian Law foresees that the members of armed forces as well

of Human Rights,¹⁰² Amnesty International,¹⁰³ the International Commission of Jurists,¹⁰⁴ the Secretary General of the United Nations,¹⁰⁵ the United Nations High Commissioner for Human Rights,¹⁰⁶ as well as certain U.S. and foreign international law scholars¹⁰⁷ have criticized the U.S. position on several grounds.

as militias associated to them which are captured by the adversary in an international armed conflict are protected by the Third Geneva Convention. There are divergent views between the United States and the ICRC on the procedures which apply on how to determine that the persons detained are not entitled to prisoner of war status.”)

¹⁰² IACHR, DECISION ON REQUEST FOR PRECAUTIONARY MEASURES (DETAINEES AT GUANTÁNAMO BAY, CUBA), 41 I.L.M. 532, 533 (2002) (“It is . . . well-known that doubt exists as to the legal status of the detainees.”)

¹⁰³ Amnesty International, *Memorandum to the U.S. Government on the rights of people in U.S. custody in Afghanistan and Guantánamo Bay* (available at [http://web.amnesty.org/aidoc/aidoc_pdf.nsf/Index/AMR510532002ENGLISH/\\$File/AMR510532.pdf](http://web.amnesty.org/aidoc/aidoc_pdf.nsf/Index/AMR510532002ENGLISH/$File/AMR510532.pdf)) (The United States’ “selective approach to the Geneva Conventions threatens to undermine the effectiveness of international humanitarian law protections for any U.S. or other combatants captured in the future.”)

¹⁰⁴ ICJ, *Rule of Law Must be Respected in Relation to Detainees in Guantánamo Bay* (Jan. 17, 2002) (available at http://www.icj.org/ews.php?id_article=2612&lang=eng) (“The United States has refused [POW] status to Taliban fighters even though, as members of the armed forces, they are entitled to it.”)

¹⁰⁵ Kofi Annan, Press Encounter outside No. 10 Downing Street, London, (Feb. 25, 2002) (unofficial transcript available at <http://www.un.org/aps/sg/offthecuff.asp?nid=103>) (“The Red Cross has indicated that anyone who was arrested in the battlefield, or picked up in the battlefield, is a prisoner of war and they do not make a difference between the Al Qaeda and the Taliban. And under the convention, where there is a disagreement, normally you have an independent tribunal to resolve this.”).

¹⁰⁶ Mary Robinson, Statement of the High Commissioner for Human Rights on Detention of Taliban and Al Qaeda Prisoners at U.S. Base in Guantánamo Bay, Cuba (Jan. 16, 2002) (available at <http://www.unhcr.ch/hurricane/hurricane.nsf/0/C537C6D4657C7928C1256B43003E7D0B?opendocument>) (“All persons detained in this context are entitled to the protection of international human rights law and humanitarian law, in particular the relevant provisions of the International Covenant on Civil and Political Rights (ICCPR) and the Geneva Conventions of 1949.”)

**Article 5 Presumes POW Status Until the Determination of Status by
a Competent Tribunal**

Critics of the Administration position argue that non-civilian detainees from the War in Afghanistan either clearly qualify as POWs or their POW status is in “doubt.” Geneva III mandates that a detainee whose status is in “doubt” must be treated as a POW until his status is decided otherwise by a competent tribunal under Article 5. Indeed, Article 5’s presumption that captured combatants are entitled to POW status until their status is determined by a competent tribunal is one that has been consistently honored by the U.S. since World War II.¹⁰⁸ Moreover, like Article 5, customary international law also includes the principle that a competent tribunal must resolve any doubt about the status of a captured combatant.¹⁰⁹ We agree with critics of the

¹⁰⁷ See, generally, George H. Aldrich, *The Taliban, Al Qaeda, and the Determination of Illegal Combatants*, 96 AM. J. INT’L L. 891 (2002); Harold Hongju Koh, *Agora: Military Commissions—The Case Against Military Commissions*, 96 AM. J. INT’L L. 337 (2002); Neil McDonald & Scott Sullivan, *Rational Interpretation in Irrational Times: The Third Geneva Convention and the War on Terror*, 44 HARV. INT’L L.J. 301 (2003); Manooher Mofidi and Amy E. Eckert, “Unlawful Combatants” or “Prisoners of War”: *The Law and Politics of Labels*, 36 CORNELL INT’L L.J. 59 (2003); Michael Ratner, *Moving Away from the Rule of Law: Military Tribunals, Executive Detentions and Torture*, 24 CARDOZO L. REV. 1513 (2003).

¹⁰⁸ See JENNIFER ELSEA, TREATMENT OF “BATTLEFIELD DETAINEES” IN THE WAR ON TERRORISM, CONG. RESEARCH SERV., RL31367, at 30 (2002) (available at <http://fpc.state.gov/documents/organization/9655.pdf>) (stating that the United States “has in the past interpreted [Article 5] as requiring an individualized assessment of status before privileges can be denied”). See also THE JUDGE ADVOCATE GENERAL’S SCHOOL, OPERATIONAL LAW HANDBOOK 22 (William O’Brien ed., 2003) (instructing judge advocates to “advise commanders that, regardless of the nature of the conflict, all enemy personnel should initially be accorded the protections of [Geneva III], at least until their status may be determined”).

¹⁰⁹ Michael J. Matheson, while serving as Deputy Legal Advisor of the U.S. State Department, stated:

We [the United States] do support the principle that, should any doubt arise as to whether a person is entitled to combatant status, he be so treated until his status has been determined by a competent tribunal, as well as the principle that if a person who has fallen into the power of an adversary is not held as a prisoner of war and is to be tried for

Administration position that all combatants whose claim to POW status is “in doubt” must be treated as POWs until such doubt has been resolved by a “competent tribunal.” Accordingly, since no tribunals have been convened for detainees from the War in Afghanistan, all such detainees must be considered POWs under Geneva III.

**The Taliban Detainees Were “Regular Armed Forces” and,
Therefore, Are Encompassed by Article 4(A) of Geneva III**
Critics of the Administration’s position that Taliban fighters are not entitled to

POW status because they do not satisfy the requirements of Article 4(a)(2) of Geneva III¹¹⁰ assert that Taliban captured in the War in Afghanistan are entitled to POW status either under Article 4(a)(1) because they are “[m]embers of the armed forces” of Afghanistan; or Article 4(a)(3) as they are “[m]embers of regular armed forces who profess allegiance to a government of an authority not recognized by the Detaining Power.”¹¹¹

Policy Arguments Favoring Broad Grant of POW Status to Non-Civilian Detainees from the War in Afghanistan
Several policy arguments favor granting POW status liberally even assuming that

Geneva III does not apply to Taliban or Al Qaeda detainees captured in the War in Afghanistan.

an offense arising out of the hostilities, he should have the right to assert his entitlement before a judicial tribunal and to have that question adjudicated.

Matheson, *supra* note 86.

¹¹⁰ Some have argued that the Taliban did comply with the requirements for Article 4(a)(2). *See, e.g.*, ROBERT GOLDMAN AND BRIAN TITTEMORE, UNPRIVILEGED COMBATANTS AND THE HOSTILITIES IN AFGHANISTAN: THEIR STATUS AND RIGHTS UNDER INTERNATIONAL HUMANITARIAN RIGHTS LAW (The Am. Soc. Of Int’l Law Task Force on Terrorism, Task Force Paper) (*available at* <http://asil.org/taskforce/goldman.pdf>.)

¹¹¹ Not only did the Taliban profess such an allegiance, but they were the strongest military partner in the Alliance, effectively controlling Afghanistan. *See* “Taliban Reach Zenith?” 85 *National Defense* 10 (Oct. 1, 2000).

First, depriving Taliban and Al Qaeda of POW status because they do not obey the laws of war sets a dangerous precedent, inviting other state parties to claim that another party is not obeying the rules of war and that they are, therefore, free from the obligations of Geneva III. International humanitarian law applies regardless of whether or not the other party to the conflict respects such laws.¹¹² Reciprocity arrangements are generally rejected in international humanitarian law as they can so easily be abused at the expense of civilians or persons rendered “hors de combat.”¹¹³

Second, it is in the U.S.’s self-interest to ensure that the Geneva Conventions – a regime of vital importance to the safety of our own armed forces – are interpreted as broadly as possible. Otherwise, an opposing state party could use the argument that the U.S. has violated the laws of war to deny captured U.S. soldiers POW status. In fact, North Korea and Vietnam have already used this argument as a basis to deny captured U.S. prisoners POW protections

¹¹² Article 1 of Geneva III states “The High Contracting Parties undertake to respect and to ensure respect for the present Convention in all circumstances.” See also *Military and Paramilitary Activities (Nicar. v. U.S.)*, 1986 I.C.J. REP. 14, 14 (June 27) (holding that Geneva III applies in all circumstances regardless of the actions of the other party to the conflict). See also, generally, Theodor Meron, *The Humanization of Humanitarian Law*, 94 AM. J. INT’L L. 239, 248-249 (2000).

¹¹³ As the ICRC Commentaries on Article 1 state: “it is not merely an engagement concluded on a basis of reciprocity, binding each party to the contract only in so far as the other party observes its obligations. It is rather a series of unilateral engagements solemnly contracted before the world as represented by the other Contracting Parties. Each State contracts obligations ‘vis-à-vis’ itself and at the same time ‘vis-à-vis’ the others. The motive of the Convention is so essential for the maintenance of civilization that the need is felt for its assertion, as much out of respect for it on the part of the signatory State itself as in the expectation of such respect from all parties.” ICRC *Commentaries to Article 1, Convention (III) relative to the Treatment of Prisoners of War, Geneva, 12 August 1949*, ICRC Database on Int’l Humanitarian Law (available at <http://www.icrc.org/ihl.nsf/b466ed681ddfcfd241256739003e6368/49cfe5505d5912dlc12563ed00424cdd?Open Document>). See also Geneva III, Art. 13.

under the Geneva Conventions.¹¹⁴ Indeed, it was reportedly these very examples that prompted Colin Powell, out of concern for the safety of U.S. forces, to request that President Bush reconsider the Administration's initial position.¹¹⁵

We accordingly urge liberal extension of POW treatment where that would encourage reciprocal treatment of U.S. service personnel and advance more generally foreign policy and national security interests. We further believe that, even to the extent that POW status is denied to detainees, such detainees must be afforded the protections of international criminal law, as well as international human rights and humanitarian law.

Geneva IV

Geneva IV applies in international armed conflicts to the same extent as Geneva III. It covers "protected persons" defined as "those who, at a given moment and in any manner whatsoever, find themselves, in case of a conflict or occupation, in the hands of a Party to the conflict or Occupying Power of which they are not nationals." *See* Geneva IV, Article 4.¹¹⁶

¹¹⁴ George H. Aldrich, *The Taliban, Al Qaeda, and the Determination of Illegal Combatants*, 96 AM. J. INT'L L. 891, 895-96 (2002) (noting that North Korea and North Vietnam denied POW status to all American prisoners on the basis of the allegation that they were all war criminals).

¹¹⁵ Colin Powell apparently made remarks to this effect in a memo leaked to the press on January 27, 2002. *See* Editorial, *Bush's Call on Captives*, THE BOSTON GLOBE, Jan. 29, 2002, at A10.

¹¹⁶ Legal commentators have argued that persons who have directly participated in the War in Afghanistan and who do not qualify as POWs under Geneva III (*i.e.*, detainees considered to be "unlawful combatants" by the U.S.) should automatically be considered "protected persons" under Geneva IV, unless other exceptions apply. *See, e.g.*, Michael Ratner, *Moving Away from the Rule of Law: Military Tribunals, Executive Detentions and Torture*, 24 CARDOZO L. REV. 1513, 1518-19 (2003) ("There is no gap between the two conventions"). Recent decisions of the International Criminal Tribunal for the Former Yugoslavia (ICTFY) have held that, "if an individual is not entitled to the protections of the Third Convention as a

The fact that a person may have unlawfully participated in a conflict is not relevant to Geneva IV protections, apart from a significant national security exemption. The term “protected persons” includes persons detained as spies or saboteurs as well as other persons suspected of engaging in activities hostile to the security of the detaining power. Specifically, Article 5 provides:

Where in the territory of a Party to the conflict, the *latter* is satisfied that an individual protected person is definitely suspected of or engaged in activities hostile to the security of the State, such individual person shall not be entitled to claim such rights and privileges under the present Convention as would, if exercised in the favour of such individual person, be prejudicial to the security of such State

....

In each case, such persons shall nevertheless be treated with humanity and, in case of trial, shall not be deprived of the rights of fair and regular trial prescribed by the present Convention. They shall also be granted the full rights and privileges of a protected person under the present Convention at the earliest date consistent with the security of the State or Occupying Power, as the case may be.

As drafted, (*i.e.*, the use of the words “the latter”), it would appear that the national security derogation is available only to the State on whose territory the conflict is occurring (*i.e.*, in the War in Afghanistan, only to the Northern Alliance), and there is no authority whether or not an allied State, such as the United States, can benefit from such exemption.

In an exception of great importance in Afghanistan, given the number of third country participants in the conflict, “protected persons” does not include “[n]ationals of a State which is not bound by the Convention,” “[n]ationals of a neutral State who find themselves in

prisoner of war (or of the First or Second Conventions) he or she necessarily falls within the ambit of [Geneva IV].” See *The Prosecutor v. Delalic*, IT-96-21-T, at para. 271 (1998); see also *Prosecutor v. Tadic*, IT-94-I-A, 38 I.L.M. 158 (1999).

the territory of a belligerent State” and “nationals of a co-belligerent State ... while the State of which they are nationals has normal diplomatic representation in the State in whose hands they are.” *See* Geneva IV, Article 4. For example, a Pakistani picked up on the battlefield in Afghanistan would fall within the exceptions to “protected person” status under Geneva IV.

However, in no event would such provision permit the State to commit “grave breaches” as defined in Article 147, which includes torture or inhuman treatment and willfully causing great suffering or serious injury to body or health, upon a “protected person”. *See* Geneva IV, Art. 146. Furthermore, to the extent that any physical or moral coercion (otherwise prohibited by Article 31 of Geneva IV) might fall below the level of “grave breach” and thus be derogable, the ICRC commentary to the national security derogations contained in Article 5 of Geneva IV, involving persons engaged in activities hostile to the security of the state notes that:

widespread application of the Article may eventually lead to the existence of a category of civilian internees who do not receive the normal treatment laid down by the Convention but are detained under conditions which are almost impossible to check. It must be emphasized most strongly, therefore, that Article 5 can only be applied in individual cases of an exceptional nature, when the existence of specific charges makes it almost certain that penal proceedings will follow. This article should never be applied as a result of mere suspicion.

Like POWs under Geneva III, “protected persons” under Geneva IV cannot be subjected to coercive interrogation tactics. Specifically, Article 31 of Geneva IV provides that “[n]o physical or moral coercion shall be exercised against protected persons, in particular to obtain information from them or from third parties.” Article 32 further provides that “any measure of such a character as to cause the physical suffering or extermination of protected persons” is prohibited and that “[t]his prohibition applies not only to murder, torture, corporal punishments, mutilation and medical or scientific experiments not necessitated by the medical

treatment of a protected person, but also to any other measures of brutality, whether applied by civilian or military agents.”

By its terms, Geneva IV ceases to apply “on the general close of military operations” in the case of an international conflict. *See* Geneva IV, Art. 6. Whether military operations have reached a “general close” after the establishment of the Karzai government in June 2002 and whether the change in character of the conflict from an international one to a multi-national conflict within a single State against non-State opponents terminated application of Geneva IV are issues open to controversy.¹¹⁷ Thus, the ability of some civilians captured in Afghanistan to claim “protected person” status under Geneva IV today is subject to additional debate. However, regardless of the characterization of the current conflict, torture and inhumane treatment of civilian detainees from the War in Afghanistan or the ongoing conflict in Afghanistan, whether or not they qualify as “protected persons” under Geneva IV, is not permitted. All such persons are still entitled to the protections of international human rights law and to humane treatment under Common Article 3 and Article 75 of Additional Protocol I.

Summary

None of the detainees from the War in Afghanistan or the ongoing conflict in Afghanistan fall outside of international humanitarian law. An individual detained during the armed conflict in Afghanistan – whether considered an international or internal armed conflict – is either protected by Geneva III as a POW, by Geneva IV as a civilian “protected person,” or, at the very minimum, by Common Article 3 and Article 75 of Additional Protocol I. Of course, all

¹¹⁷ Such determination does not negate application of Common Article 3 to an “armed conflict not of an international character” or certain other provisions of international humanitarian law and the law of armed conflict.

detainees – regardless of where or when they were captured – are entitled to the protection of human rights law (including CAT and the ICCPR) and customary international law.

Detainees protected as POWs or civilians under Geneva III or Geneva IV cannot be subjected to coercion of any kind. In addition, those detainees whose POW status is in doubt are entitled to interim POW status until a competent tribunal determines otherwise. At least some Afghan detainees are entitled to such tribunals, and the U.S. is long overdue in providing any process whatsoever to detainees, many of whom may simply be innocent non-combatants, wrongfully detained. We, therefore, urge the U.S. to establish proper screening procedures for all detainees.

OTHER INTERNATIONAL LEGAL STANDARDS

The legal standards set forth in the International Covenant on Civil and Political Rights, the American Declaration of the Rights and Duties of Man, and customary international law also apply to the treatment of detainees held by the United States.

The International Covenant on Civil and Political Rights¹¹⁸

Relevant Legal Standards

Like CAT, the ICCPR expressly prohibits both torture and CID. Specifically, Article 7 of the ICCPR provides: “No one shall be subjected to torture or to cruel, inhuman or degrading treatment or punishment.”¹¹⁹ However, the ICCPR goes further than CAT in its non-

¹¹⁸ The ICCPR, G.A. Res. 2200A (XXI), U.N. GAOR, 21st Sess., Supp. No. 16, at 52, U.N. Doc. A/6316, 999 U.N.T.S. 171 was adopted in 1966 and came into force in 1976. It was ratified by the United States in 1992, subject to a number of reservations, understandings and declarations. See 138 CONG. REC. S4781-01 (1992).

¹¹⁹ Congressional ratification of the ICCPR with respect to the prohibition against cruel, inhuman or degrading treatment is subject to a reservation mirroring that taken by the U.S.

derogability provision, expressly stating that neither torture nor CID treatment can be justified by exceptional circumstances such as war, internal political stability or other public emergencies. (See ICCPR, Art. 4). Article 10 also provides that: “All persons deprived of their liberty shall be treated with humanity and with respect for the inherent dignity of the human person.”

The Human Rights Committee, established under Article 28, adjudicates complaints filed by individuals or states parties alleging violations of the ICCPR. The Committee has found the following conduct to violate Article 7’s prohibition against cruel, inhuman or degrading treatment or punishment: threatening a victim with torture, prolonged solitary confinement and incommunicado detention, and repeated beatings.¹²⁰ Moreover, the Human Rights Committee has specifically criticized interrogation procedures such as handcuffing, hooding, shaking and sleep deprivation as violations of Article 7 in any circumstances.¹²¹

Although the ICCPR does not expressly prohibit states parties from “rendering” individuals to countries where they are likely to be mistreated, the Human Rights Committee has explained that, under Article 7, states parties “must not expose individuals to the danger of torture or cruel, inhuman or degrading treatment or punishment upon return to another country

under CAT: “The United States considers itself bound by Article 7 to the extent that ‘cruel, inhuman, or degrading treatment or punishment’ means the cruel and unusual treatment or punishment prohibited by the Fifth, Eighth and/or Fourteenth Amendments....” *Id.*

¹²⁰ See *Floyd Howell v. Jamaica*, Communication No. 798/1998 (20 January 1998), CCPR/C/79/D/798/1998; *Victor Alfredo Polay Campos*, Communication No. 577/1994 (6 November 1997), CCPR/C/61/D/577/1994; *Dave Marais, Jr. v. Madagascar*, Communication No. 49/1979 (19 April 1979), U.N. Doc. Supp. No. 40 (A/38/40) at 141 (1983); *Raul Sendic Antonaccio v. Uruguay*, Communication No. R.14/63 (28 November 1979), U.N. Doc. Supp. No. 40 (A/37/40) at 114 (1982).

¹²¹ See Concluding Observations of the Human Rights Committee (Israel), CCPR/C/79/Add.93 (1998).

by way of their extradition, expulsion or refoulement.”¹²² Accordingly, the Human Rights Committee has stated that “[i]f a State party extradites a person within its jurisdiction in circumstances such that as a result there is a real risk that his or her rights under the Covenant will be violated in another jurisdiction, the State party itself may be in violation of the Covenant.”¹²³

Enforcement

U.S. Courts

In ratifying the ICCPR, the U.S. Senate declared that Articles 1 through 27 are not self-executing. Thus, while the Supreme Court has not squarely decided the issue, the majority of federal appeals courts have held that the ICCPR provides no privately enforceable rights and is not binding on federal courts.¹²⁴ The Second and Ninth circuit courts, however, have cited the

¹²² See General Comment 20, U.N. GAOR Hum. Rts. Comm., 47th Sess., Supp. No. 40, para. 9, U.N. Doc. A/47/40 (1992).

¹²³ *Kindler v. Canada*, Communication No. 470/1991, Human Rights Committee, U.N. Doc. CCPR/C/48/D/470/1990 (1993).

¹²⁴ See, e.g., *Poindexter v. Nash*, 333 F.3d 372, 379 (2d Cir. 2003); *Bannerman v. Snyder*, 325 F.3d 722, 724 (6th Cir. 2003); *Wesson v. U.S. Penitentiary Beaumont, TX*, 305 F.3d 343, 348 (5th Cir. 2002); *United States v. Duarte-Acero*, 296 F.3d 1277, 1283 (11th Cir. 2002); *Hain v. Gibson*, 287 F.3d 1224, 1243 (10th Cir. 2002); *United States v. Warden, FMC Rochester*, 286 F.3d 1059, 1063 (8th Cir. 2002); *Dutton v. Warden, FCI Estill*, 2002 WL 255520, at *1 (4th Cir. 2002); *Lal v. Roe*, 2002 WL 31356505, at *1 (9th Cir. 2002); *Beazley v. Johnson*, 242 F.3d 248, 267 (5th Cir. 2001); *Kenan v. U.S.P. Lompac*, 2001 WL 1003213, at *1 n.1 (9th Cir. 2001); *Igartua De La Rosa v. United States*, 32 F.3d 8, 10 n.1 (1st Cir. 1994); see also *Beshli v. Dept. of Homeland Security*, 2003 WL 21693668, at *10 (E.D. Pa. July 22, 2003); *Macharia v. United States*, 238 F. Supp. 2d 13, 29-30 (D.D.C. July 30, 2002); *Reaves v. Warden, U.S.P.*, 2002 WL 535398, at *9 (M.D. Pa. Mar. 22, 2002); *Jama v. United States Immigration and Naturalization Service*, 22 F. Supp. 2d 353, 364-65 (D.N.J. 1998).

ICCPR as evidence that customary international law prohibits arbitrary arrest, prolonged detention and torture.¹²⁵

The Human Rights Committee

The Human Rights Committee is empowered to: (i) receive state party reports and comment on those reports (*see* ICCPR, Art. 40(4)); (ii) rule on complaints filed by a state party that another state party is not fulfilling its obligations under the ICCPR (*see* ICCPR, Art. 41);¹²⁶ and (iii) rule on complaints filed by individuals “who claim that any of their rights enumerated in the Covenant have been violated and who have exhausted all available domestic remedies.”¹²⁷

Organization of American States’ Instruments

Relevant Legal Standards

The U.S. is a member of the Organization of American States (the “OAS”).

Article XXV of The American Declaration of the Rights and Duties of Man (the “American Declaration”), which was adopted by the Ninth International Conference of the OAS in 1948, provides:

¹²⁵ *See Kim Ho Ma v. Ashcroft*, 257 F.3d 1095, 1114 (9th Cir. 2001) (recognizing that an international prohibition exists against “prolonged and arbitrary detention” and citing, among other sources to ICCPR, Art. 9); *Martinez v. City of Los Angeles*, 141 F.3d 1373, 1383-84 (9th Cir. 1998) (same); *United States v. Romano*, 706 F.2d 370, 375 n.1 (2d Cir. 1983) (citing to ICCPR for articulation of rights of a person charged with a criminal offense); *Filartiga v. Peña-Irala*, 630 F.2d 876, 883-84 (2d Cir. 1980) (citing ICCPR as one example that international law universally rejects torture).

¹²⁶ In ratifying the ICCPR, the U.S. Senate declared that “The United States . . . accepts the competence of the Human Rights Committee to receive and consider communications under Article 41 in which a State Party claims that another State Party is not fulfilling its obligations under the Covenant.” *See supra* note 118.

¹²⁷ *See* Optional Protocol to the International Covenant on Civil and Political Rights, 21 U.N. GAOR Supp. (No. 16) at 59, U.N. Doc. A/6316 (1966), 999 U.N.T.S. 302.

Every individual who has been deprived of his liberty has the right to have the legality of his detention ascertained without delay by a court, and the right to be tried without undue delay or, otherwise, to be released. He also has the right to humane treatment during the time he is in custody.

On June 1, 1997, the U.S. signed, but has not yet ratified, the American Convention On Human Rights (1969) (the “American Convention”).¹²⁸ Article 5 of the American Convention, which sets forth Rights to Humane Treatment, provides:

1. Every person has the right to have his physical, mental, and moral integrity respected.
2. No one shall be subjected to torture or to cruel, inhuman or degrading punishment or treatment. All persons deprived of their liberty shall be treated with respect for the inherent dignity of the human person.

Moreover, pursuant to Article 27(2) of the American Convention, the Rights to Humane Treatment may not be suspended “[i]n time of war, public danger, or other emergency that threatens the independence or security of a State Party.”

With respect to the treatment of detainees, the Inter-American Commission on Human Rights (the “Inter-American Commission”) – which represents all member countries of the OAS and was established under Chapter VII of the American Convention – has determined that, “when the State holds a person in detention and under its exclusive control, it becomes the guarantor of that person’s safety and rights.”¹²⁹ In this regard, the Commission has found the following practices to be violations of Article 5 of the American Convention: threats to summon family members and pressure them to “talk”; threats to kill detainees; blindfolding detainees and forcing them to run around; “prolonged isolation and deprivation of communication”; solitary

¹²⁸ 1144 U.N.T.S. 123, *reprinted in* 9 I.L.M. 101 (1969).

¹²⁹ *See Manrique v. Peru*, Report No. 56/98, Inter-Am. C.H.R., OEA/Ser.L/V/II.95 Doc. 7 rev. at 983 (1998).

confinement; confining detainees in small cells with other prisoners; keeping detainees in cells that are damp and/or without adequate ventilation; keeping detainees in cells without beds; forcing detainees to sleep on the floor or on newspaper; depriving detainees of necessary hygiene facilities; beatings with rifles; and kicks in various parts of the body, especially in the stomach.¹³⁰

The Inter-American Court of Human Rights (the “Inter-American Court”) – established pursuant to Chapter VIII of the American Convention – has held that, “in order to establish if torture has been inflicted and its scope, all the circumstances of the case should be taken into consideration, such as the nature and context of the respective aggressions, how they were inflicted, during what period of time, the physical and mental effects and, in some case, the sex, age and state of health of the victims.”¹³¹ “The violation of the right to physical and psychological integrity of persons is a category of violation that has several gradations and embraces treatment ranging from torture to other types of humiliation or cruel, inhuman or degrading treatment with varying degrees of physical and psychological effects caused by endogenous and exogenous factors which must be proven in each specific situation.”¹³²

The Inter-American Court has found the following practices to violate Article 5 of the American Convention and/or Article 2 of the Inter-American Convention To Prevent and

¹³⁰ See, e.g., *Request for Advisory Opinion OC-16, by the State of Mexico, of December 10, 1997*, OEA/Ser.L/V/III.39, Doc. 5, at para. 23(d) (1998); *Manrique v. Peru*, Report No. 56/98, Inter-Am. C.H.R., OEA/Ser.L/V/II.95 Doc. 7 rev. at 983, at paras. 87-88 (1998); *Congo v. Ecuador*, Report No. 63/99, Inter-Am. C.H.R., OEA/Ser.L/V/II.95 Doc. 7 rev. at 475, at paras. 55-59 (1998); *Lucio Parada Cea, et al. v. El Salvador*, Report No. 1/99, Inter-Am. C.H.R., OEA/Ser.L/V/II.95 Doc. 7 rev. at 531, at para. 70 (1998).

¹³¹ *Villagran Morales et al. Case (the “Street Children” Case)*, Judgment of November 19, 1999, Inter-Am. Ct. H.R. (Ser. C) No. 63, at para. 74 (1999).

¹³² *Loayza-Tamayo Case*, Judgment of September 17, 1997, Inter-Am. Ct. H.R. (Ser. C) No. 33, at para. 57 (1997).

Punish Torture:¹³³ forcing detainees to stand blindfolded with their hands cuffed behind their backs; forcing detainees to listen to the cries of others being beaten; threatening detainees with physical torture; restriction of visiting rights; incommunicado detention; incarceration in solitary confinement and/or in a small cell with no ventilation or natural light; prohibiting detainees from engaging in physical exercise or intellectual efforts; deprivation of necessary hygiene facilities; deficient medical treatment; and throwing detainees to the ground.¹³⁴ “[A]ccording to international standards for protection, torture can be inflicted not only via physical violence, but also through acts that produce severe physical, psychological or moral suffering in the victim.”¹³⁵ The Inter-American Court also has held that: “Prolonged isolation and being held incommunicado constitute, in themselves, forms of cruel and inhuman treatment, harmful to the mental and moral integrity of the person and to the right of all detainees of respect for the inherent dignity of the human being.”¹³⁶

¹³³ The U.S. is not a signatory to the Inter-American Convention To Prevent and Punish Torture, O.A.S. Treaty Series No. 67. Article 2 of this Convention defines torture as “any act intentionally performed whereby physical or mental pain or suffering is inflicted on a person for purposes of criminal investigation, as a means of intimidation, as personal punishment, as a preventive measure, as a penalty, or for any other purpose. Torture shall also be understood to be the use of methods upon a person intended to obliterate the personality of the victim or to diminish his physical or mental capacities, even if they do not cause physical pain or mental anguish.”

¹³⁴ See, e.g., *Cantoral Benavides Case, Judgment of August 18, 2000*, Inter-Am. Ct. H.R. (Ser. C) No. 69, at paras. 43(a), 63(e)–(k), 104, 106 (2000); *Loayza-Tamayo Case, Judgment of September 17, 1997*, Inter-Am. Ct. H.R. (Ser. C) No. 33, at para. 58 (1997); *Castillo-Paez Case, Judgment of November 3, 1997*, Inter-Am. Ct. H.R. (Ser. C) No. 34, at para. 66 (1997); *Suarez-Rosero Case, Judgment of November 12, 1997*, Inter-Am. Ct. H.R. (Ser. C) No. 35, at para. 91 (1997).

¹³⁵ *Cantoral Benavides Case, Judgment of August 18, 2000*, Inter-Am. Ct. H.R. (Ser. C) No. 69, at para. 100.

¹³⁶ See *Fairen-Garbi and Solis Corrales Case, Judgment of March 15, 1989*, Inter-Am. Ct. H.R. (Ser. C) No. 6, at para 149 (1989); *Godinez-Cruz Case, Judgment of January 20, 1989*, Inter-

Moreover, the Inter-American Court has warned that the fact that a State is confronted with terrorism does not, in itself, warrant the use of force:

Any use of force that is not strictly necessary, given the behavior of the person detained, constitutes an affront to human dignity . . . in violation of Article 5 of the American Convention. The need to conduct investigations and the undeniable difficulties inherent to combating terrorism are not grounds for placing restrictions on the protection of the physical integrity of the person.¹³⁷

In a case brought before the Inter-American Commission by detainees alleging violations of the United States' obligations under the American Declaration by U.S. armed forces in Grenada in 1983, *Coard, et al. v. United States*, the Inter-American Commission expressly extended the protections of human rights and humanitarian norms to extraterritorial conduct by U.S. military forces and criticized the U.S. for delay in providing procedure to detainees.¹³⁸ Acknowledging the need to balance between public security and individual rights, the Inter-

Am. Ct. H.R. (Ser. C) No. 5, at para. 164 (1989); *Velazquez-Rodriguez Case, Judgment of July 29, 1988*, Inter-Am. Ct. H.R. (Ser. C) No. 4, at para. 156 (1988). In the *Suarez-Rosero* case, the Inter-American Court explained that incommunicado detention is "an exceptional measure" which can cause the detainee to suffer extreme psychological and moral injury. "[I]solation from the outside world produces moral and psychological suffering in any person, places him in a particularly vulnerable position, and increases the risk of aggression and arbitrary acts in prisons." *Suarez-Rosero Case, Judgment of November 12, 1997*, Inter-Am. Ct. H.R. (Ser. C) No. 35, at para. 90 (1997).

¹³⁷ See *Castillo-Petruzzi Case, Judgment of May 30, 1999*, Inter-Am. Ct. H.R. (Ser. C) No. 52, at para. 197 (1999).

¹³⁸ *Coard, et al. v. United States*, Inter-Am. C.H.R. Report No. 109/99 (Sept. 29, 1999) ("*Coard*"). The *Coard* petitioners alleged that U.S. forces arrested them during the period in which it consolidated control over Grenada; that they were held incommunicado for many days; and that months passed before they were taken to a magistrate, or allowed to consult with counsel. "During this period petitioners were threatened, interrogated, beaten, deprived of sleep and food and constantly harassed." *Coard*, at para. 17. The petitioners alleged that their whereabouts were kept secret, and that requests by lawyers and others to meet with them were rejected. They also alleged that U.S. forces subjected them to threats and physical abuse – including threatening to hand the detainees over to Caribbean authorities and allowing Caribbean authorities to "soften" the detainees. *Coard*, at paras. 18-19.

American Commission in *Coard* held that: “What is required when an armed force detains civilians is the establishment of a procedure to ensure that the legality of the detention can be reviewed without delay and is subject to supervisory control. . . . [C]ontrol over a detention [cannot] rest[] exclusively with the agents charged with carrying it out.” *Coard*, at paras. 58-59.

Enforcement

The Inter-American Commission has competence with respect to matters relating to the fulfillment of the commitments made by the States Parties to the American Convention.¹³⁹ “The main function of the Commission” is “to promote respect for and defense of human rights.”¹⁴⁰ Any person may lodge a petition with the Commission complaining of violation of the American Convention by a State Party, so long as effective domestic remedies available to the petitioner have been exhausted.¹⁴¹

On March 12, 2002, in response to a petition challenging detentions at Guantánamo Bay coordinated by the Center for Constitutional Rights,¹⁴² the Inter-American Commission adopted precautionary measures addressed to the United States concerning the

¹³⁹ See *supra* note 128, Art. 33.

¹⁴⁰ *Id.*, Art. 41. The Commission has also been willing to apply other relevant legal standards, including the Geneva Conventions.

¹⁴¹ *Id.*, Arts. 44 and 46. The Inter-American Court also has competence with respect to matters relating to the fulfillment of the commitments made by the States Parties to the American Convention. *Id.*, Art. 33. Only States Parties and the Commission have the right to submit a case to the Inter-American Court, however, and only after the case has been considered by the Inter-American Commission. *Id.*, Art. 61.

¹⁴² A federal habeas corpus petition on behalf of named detainees at Guantánamo which was filed in parallel was dismissed for lack of jurisdiction because “the military base at Guantánamo Bay, Cuba is outside the sovereign territory of the United States.” *Rasul v. Bush*, 215 F. Supp. 2d 55, 72 (D.D.C. 2002), *cert. granted*, 2003 WL 22070599 (U.S. Nov. 10, 2003).

Guantánamo detainees.¹⁴³ Specifically, the Commission asked the U.S. “to take the urgent measures necessary to have the legal status of the detainees at Guantánamo Bay determined by a competent tribunal.”¹⁴⁴ In so doing, the Inter-American Commission explained:

[W]here persons find themselves within the authority and control of a state and where a circumstance of armed conflict may be involved, their fundamental rights may be determined in part by reference to international humanitarian law as well as international human rights law. Where it may be considered that the protections of international humanitarian law do not apply, however, such persons remain the beneficiaries at least of the non-derogable protections under international human rights law. In short, no person under the authority and control of a state, regardless of his or her circumstances, is devoid of legal protection for his or her fundamental and non-derogable human rights.¹⁴⁵

With regard to the Guantánamo Bay detainees in particular, the Inter-American Commission observed that: “[T]he information available suggests that the detainees remain entirely at the unfettered discretion of the United States government. Absent clarification of the legal status of the detainees, the Commission considers that the rights and protections to which they may be entitled under international or domestic law cannot be said to be the subject of

¹⁴³ See Rules of Procedure of the Inter-American Commission on Human Rights, Art. 25(1): “In serious and urgent cases, and whenever necessary according to the information available, the Commission may, on its own initiative or at the request of a party, request that the State concerned adopt precautionary measures to prevent irreparable harm to persons.”)

¹⁴⁴ *Ref. Detainees in Guantánamo Bay, Cuba Request for Precautionary Measures*, Inter-Am. C.H.R., Mar. 13, 2002, reprinted in 41 I.L.M. 532, 532. The Commission has ruled that OAS member states are subject to an international legal obligation to comply with a request for precautionary measures. See *Fifth Report on the Situation of Human Rights in Guatemala*, Inter-Am. C.H.R. OEA/Ser.L/V/II.111, Doc. 21 rev. (2001), at paras. 71-72 (2001); *Case 12.243*, Inter-Am. C.H.R. OEA/Ser.L/V/II.111, Doc. 21 rev. 1255 (2000), at para. 117.

¹⁴⁵ 41 I.L.M. at 533.

effective legal protection by the State.”¹⁴⁶ The Inter-American Commission further noted that, regardless of the legal status of the Guantánamo Bay detainees, their legal protections “may in no case fall below the minimal standards of non-derogable rights.”¹⁴⁷ Thereafter, the Commission issued a renewed request to the U.S. government for precautionary measures, stating that new factual allegations regarding torture or other ill-treatment of detainees “raise questions concerning the extent to which the United States’ policies and practices in detaining and interrogating persons in connection with its anti-terrorist initiatives clearly and absolutely prohibit treatment that may amount to torture or may otherwise be cruel, inhuman or degrading as defined under international norms.”¹⁴⁸

¹⁴⁶ *Id.*

¹⁴⁷ *Id.*, at 534. The Inter-American Commission invited the U.S. to provide information concerning compliance with these precautionary measures. In response, the United States argued that: (i) the Commission did not have jurisdiction to apply international humanitarian law, particularly the Geneva Conventions, as well as customary international humanitarian law; (ii) the Commission lacks authority to request precautionary measures with respect to States which are not party to the American Convention; and (iii) in any event, precautionary measures are neither necessary nor appropriate because the detainees are not entitled to prisoner of war status, do not meet Geneva Convention criteria for lawful combatants and are, instead, enemy combatants. *See Response of the United States To Request For Precautionary Measures – Detainees in Guantánamo Bay, Cuba, reprinted in 41 I.L.M. 1015, 1028-1030 (2002)*. The U.S. stated, however, that it “is providing the detainees with protections consistent with international humanitarian law.” *Id.* at 1031. The U.S. also asserted that it had no obligation to convene a tribunal to determine the detainees’ status, and that the detainees had no right to counsel or to have access to courts. *Id.* at 1034. The U.S. Response did not address interrogation techniques. However, on December 2, 2003, the Pentagon announced that U.S. citizen and Taliban soldier Yaser Esam Hamdi would be given access to a lawyer, “as a matter of discretion and military policy,” but that the decision “should not be treated as a precedent” and was “subject to appropriate security restrictions.” *See Associated Press Newswires, Pentagon OKs Lawyer For Terror Suspect*, Dec. 3, 2003; Jerry Markon and Dan Eggen, *U.S. Allows Lawyer For Citizen Held as “Enemy Combatant”*, WASH. POST, Dec. 3, 2003, at A01.

¹⁴⁸ *Ref. Detainees in Guantánamo Bay, Cuba Request for Precautionary Measures*, Inter-Am C.H.R., July 23, 2003, at 5.

Customary International Law and *Jus Cogens*

Relevant Legal Standards

Customary international law has long prohibited the state practice of torture, without reservation, in peace or in wartime.¹⁴⁹ On December 9, 1975, the United Nations General Assembly adopted by consensus the Declaration on the Protection of All Persons from Being Subjected to Torture and Other Cruel, Inhuman or Degrading Punishment.¹⁵⁰ The Torture Resolution together with CAT and the ICCPR – ratified by 133 and 151 States, respectively – embody the customary international law obligation to refrain from behavior which constitutes torture.¹⁵¹ In addition, in 1985 the United Nations Special Rapporteur on Torture, Pieter

¹⁴⁹ In order for a state's practice to be recognized as customary international law, it must fulfill two conditions:

Not only must the acts concerned amount to a settled practice, but they must also be such, or be carried out in such a way, as to be evidence of a belief that this practice is rendered obligatory by the existence of a rule of law requiring it. The need for such a belief, *i.e.*, the existence of a subjective element, is implicit in the very notion of the *opinio juris sive necessitas*. The States concerned must therefore feel that they are conforming to what amounts to a legal obligation.

North Sea Continental Shelf (*F.R.G. v. Den.*), 1969 I.C.J. 3, 44. *See also* Military and Paramilitary Activities (*Nicar v. U.S.*), 1986 I.C.J. 14, 14; R. JENNINGS & A. WATTS, *OPPENHEIM'S INTERNATIONAL LAW*, (9th ed. 1996); *The Paquete Habana*, 175 U.S. 677, 700 (1900) (cited with approval in *First Nat'l City Bank v. Banco Para El Comercio Exterior de Cuba*, 462 U.S. 611, 623 (1983)); *U.S. v. Yousef*, 327 F.3d 56, 92 (2d Cir. 2002).

¹⁵⁰ GA Res. 3452 (XXX), U.N. GAOR, Supp. No. 34 at 91 (hereinafter the "Torture Resolution").

¹⁵¹ *See Report by the Special Rapporteur*, U.N. Economic and Social Council, E/CN.4/1986/15, at para. 3. The report details state practice and *opinio juris* with respect to national legislation prohibiting torture. *See also* HERMAN J. BURGERS & HANS SANELIUS, *THE UNITED NATIONS CONVENTION AGAINST TORTURE AND OTHER CRUEL, INHUMAN OR DEGRADING TREATMENT OR PUNISHMENT* (Martinus Nijhoff Publishers/Kluwer Academic Publishers 1988), at 1-12. The widespread ratification of regional human rights instruments such as the European Convention for the Protection of Human Rights and Fundamental Freedoms, the

Koojimans, noted the widespread existing domestic legislation in many countries, including the United States, expressly or by implication prohibiting torture as well as cruel, inhuman and degrading punishment.¹⁵²

The prohibition of torture is, moreover, one of the few norms which has attained peremptory norm or *jus cogens* status, and is recognized as such by United States courts.¹⁵³ *Jus cogens* is defined as a peremptory norm “accepted and recognized by the international community of states as a whole as a norm from which no derogation is permitted and which can be modified only by a subsequent norm of general international law having the same character.”¹⁵⁴ While many international agreements expressly prohibit both torture and cruel, inhuman and degrading treatment,¹⁵⁵ it remains an open question as to whether *jus cogens* status

American Convention on Human Rights and the African Charter on Human and Peoples’ Rights further reinforce the argument that torture is prohibited by customary international law.

¹⁵² *Report by the Special Rapporteur, id.*, at paras. 72, 82.

¹⁵³ See RESTATEMENT (THIRD) OF FOREIGN RELATIONS LAW § 702 (1986). See also *Abebe-Jira v. Negewo*, 72 F.3d 844, 847 (11th Cir. 1996); *In re Estate of Ferdinand Marcos, Human Rights Litigation*, 25 F.3d 1467, 1475 (9th Cir. 1994); *Siderman de Blake v. Republic of Argentina*, 965 F.2d 699, 716 (9th Cir. 1992); *Cornejo-Barreto v. Seifert*, 218 F.3d 1004, 1006 (9th Cir. 2000); *Presbyterian Church of Sudan v. Talisman Energy, Inc.*, 244 F. Supp. 2d 289 (S.D.N.Y. 2003); *Mehinovic v. Vuckovic*, 198 Supp. 2d 1322 (N.D. Ga. 2002); *Doe v. Islamic Salvation Front*, 993 F. Supp. 3, 7 (D.D.C. 1998); *Doe v. Unocal*, 963 F. Supp. 880, 890 (C.D. Cal. 1997).

¹⁵⁴ Vienna Convention on the Law of Treaties, 1969, Art. 53, 1155 U.N.T.S. 331.

¹⁵⁵ See, e.g., Universal Declaration of Human Rights, G.A. Res. 217, U.N. GAOR, 3d Sess., Art. 5, U.N. Doc. A/810 (1948) (“no one shall be subjected to torture or to cruel, inhuman or degrading treatment or punishment”); Declaration on the Protection of All Persons from Being Subjected to Torture and Other Cruel, Inhuman or Degrading Treatment or Punishment, G.A. Res. 3452, 30 U.N. GAOR, Supp. No. 34, U.N. Doc. A/10034 (1976), at Art. 3 (“Exceptional circumstances such as a state of war or a threat of war, internal political stability or any other public emergency may not be invoked as a justification of torture or other cruel, inhuman or degrading treatment or punishment.”); ICCPR, *supra* note 118, at Art. 7 (“no one shall be subjected to torture or to cruel, inhuman or degrading treatment or

extends to the prohibition against cruel, inhuman or degrading treatment. What is clear, however, is that cruel, inhuman and degrading treatment or punishment is prohibited by customary international law.

U.S. ratification of the ICCPR and CAT are clear pronouncements that we condemn the practice of torture and CID treatment and that we consider ourselves legally bound to prohibit such conduct. Indeed, in 1999, the United States issued a report to the U.N. Committee Against Torture categorically affirming that:

Every act constituting torture under the Convention constitutes a criminal offense under the law of the United States. No official of the Government, federal, state or local, civilian or military, is authorized to commit or to instruct anyone else to commit torture. Nor may any official condone or tolerate torture in any form. No exceptional circumstances may be invoked as justification for torture. United States law contains no provision permitting otherwise prohibited acts of torture or other cruel, inhuman or degrading treatment or punishment to be employed on grounds of exigent circumstance (for example, during a "state of public emergency") or on orders from a superior officer or public authority, and the protective mechanisms of an independent judiciary are not subject to suspension.¹⁵⁶

punishment"); Additional Protocol I, *supra* note 20, at Art. 75; Protocol Additional to the Geneva Conventions of 12 August 1949, and Relating to the Protection of Victims of Non-International Armed Conflicts ("Additional Protocol II"), *reprinted in* 16 I.L.M. 1442 (1977), at Art. 4; European Convention for the Protection of Human Rights and Fundamental Freedoms, 213 U.N.T.S. 221 (1950), at Art. 3 (declaring that torture and inhuman or degrading treatment or punishment is prohibited); American Convention, *supra* note 128, at Art. 5 (providing that every person retain the right to be free from torture and ill-treatment); African Charter on Human and Peoples' Rights, *reprinted in* 21 I.L.M. 58 (1981), at Art. 5 (prohibiting torture and ill-treatment).

¹⁵⁶ Committee Against Torture, *Consideration of Reports Submitted by States Parties Under Article 19 of the Convention*, United States of America, U.N. Doc. CAT/C/28/Add.5 (2000) ("U.S. Report Under CAT"), at para. 6.

Furthermore, the United States has enacted the Torture Victim Protection Act,¹⁵⁷ has imposed civil liability for acts of torture regardless of where such acts take place,¹⁵⁸ and has enacted the Torture Victims Relief Act, providing for monetary assistance for torture victims.¹⁵⁹ As previously discussed, not only does the U.S. Constitution prohibit cruel and unusual punishment or treatment by state officials (including under the military justice system), but almost all of the U.S. State constitutions have similar prohibitions.¹⁶⁰ Finally, a number of federal judicial proceedings have recognized that the right to be free from torture as well as cruel, inhuman or degrading treatment or punishment is a norm of customary international law.¹⁶¹

In the State Department Country Reports On Human Rights Practices, for example, the United States has expressly characterized the following types of conduct – some of which are allegedly occurring at U.S. detention centers – as “torture” or “other abuse”: tying detainees in painful positions; forcing detainees to stand for long periods of time; incommunicado detention; depriving detainees of sleep; dousing naked detainees with cold water; denial of access to medical attention; interrogation techniques designed to intimidate or disorient; subjecting a detainee to loud music; forcing a detainee to squat or to assume “stressful, uncomfortable or painful” positions for “prolonged periods of time”; long periods of

¹⁵⁷ 28 U.S.C. § 1350.

¹⁵⁸ *Id.*

¹⁵⁹ 22 U.S.C. § 2152.

¹⁶⁰ See Part I of this Report; U.S. Report Under CAT, at paras. 50, 301 - 348.

¹⁶¹ See *Abebe-Jira v. Negero*, 72 F.3d 844 (11th Cir. 1996), *cert. denied*, 519 U.S. 830 (1996); *Najarro de Sanchez v. Banco Central de Nicaragua*, 770 F.2d 1385 (5th Cir. 1985); *Xuncax v. Gramajo*, 886 F. Supp. 162 (D. Mass. 1995); *Paul v. Avril*, 901 F. Supp. 330 (S.D. Fla. 1994).

imprisonment in darkened rooms; verbal threats; and instilling detainees with the false belief that they are to be killed.¹⁶² The following types of conduct have been defined as cruel, inhuman or degrading treatment: stripping; confinement in severely overcrowded cells; beating; imprisonment in small containers; and threats against family members of detainees.¹⁶³

Enforcement

As the Second Circuit stated in *Filartiga v. Peña-Irala*, 630 F.2d 876 (1980), the United States is bound by customary international law. Thus, in cases where jurisdictional hurdles have been met, the bans on torture, arbitrary detention, and at least some aspects of cruel, inhuman and degrading treatment have been enforced by U.S. courts as violations of customary international law.¹⁶⁴

SHOULD EXCEPTIONS BE MADE FOR THE “WAR ON TERROR”?: THE EXPERIENCE OF OTHER JURISDICTIONS

Notwithstanding the clear legal prohibitions against the use of torture and cruel, inhuman or degrading treatment in U.S. and international law, we considered whether, in a post-September 11 world, the threat posed by terrorists to the United States could ever justify the use of prohibited interrogation practices. We sought to answer the question of whether there are any

¹⁶² See U.S. Dept. of State, Bureau of Democracy, Human Rights and Labor, *Country Reports on Human Rights Practices – 2002* (for Brazil, Burma, China, Egypt, Israel and the occupied territories, Jordan, Kenya, Democratic People’s Republic of Korea, Laos, Pakistan, Saudi Arabia, Togo, Turkey and Zimbabwe) (Mar. 31, 2003).

¹⁶³ *Id.* (for Cameroon, Mongolia, Nigeria and Rwanda).

¹⁶⁴ See, e.g., *Filartiga v. Peña-Irala*, 639 F.2d 876 (2d Cir. 1980) (allowing a torture claim to be prosecuted under the Alien Tort Claims Act, 28 U.S.C. § 1350); see also *Forti v. Suarez-Mason*, 672 F. Supp. 1531, 1541-43 (N.D. Cal. 1987) (recognizing torture and arbitrary detention as violations of customary international law, but finding that universal consensus regarding right to be free from cruel, inhuman and degrading treatment had not yet been established).

circumstances in which torture and CID treatment in the interrogation of detainees should be permitted.

For additional guidance in answering these questions, we looked to the experiences of Northern Ireland and Israel, other places where the struggle between fighting terrorism and upholding the rule of law has been waged. Both the European Court of Human Rights and the Israeli Supreme Court have confronted the contradictory demands of national security and human rights against the backdrop of terrorism. The legal debate that infuses these courts' seminal decisions on the use of torture and CID treatment in the interrogation of terrorist suspects offers guidance to the United States in interpreting CAT. These courts have ruled that there are no exceptions to the prohibition against torture and CID treatment. Their rulings express the conviction that the torture and CID treatment of detainees – even when those detainees are suspected terrorists – cannot be justified.

Legal Challenges to Interrogation Practices in Northern Ireland and Israel

The Republic of Ireland v. The United Kingdom

The European Convention for the Protection of Human Rights and Fundamental Freedoms (the “European Convention”) came into force in 1953.¹⁶⁵ Article 3 of the European Convention provides: “No one shall be subject to torture or to inhuman or degrading treatment or punishment.” The judicial body primarily charged with interpreting and enforcing the European Convention is the European Court of Human Rights (the “ECHR”). The ECHR has, in several decisions, applied the European Convention’s prohibition against torture and inhuman or degrading treatment to cases involving interrogation of suspected terrorists who pose a threat to national security.

¹⁶⁵ 213 U.N.T.S. 221.

The most important of these decisions is *The Republic of Ireland*.¹⁶⁶ *The Republic of Ireland* case was decided in a legal and political environment conditioned by several years of terrorism in Northern Ireland perpetrated by members of the Irish Republican Army (IRA) and Loyalist groups. By March 1975, over 1,100 people had been killed, over 11,500 injured and £140 million worth of property destroyed.¹⁶⁷ To combat a campaign of violence being carried out by the IRA, in 1971, the Northern Ireland Government introduced regulations providing authorities with extrajudicial powers, including arrest for interrogation purposes and internment.¹⁶⁸

The Republic of Ireland Decision is a landmark legal discussion of whether specific interrogation practices committed by British security forces against IRA detainees constituted torture or inhuman or degrading treatment. The impetus for the ECHR's decision was the Republic of Ireland's application before the European Commission of Human Rights alleging, among other things, that various interrogation practices – including specific practices referred to as the “five techniques” – amounted to torture and inhuman or degrading treatment, in contravention of Article 3 of the European Convention.¹⁶⁹ The “five techniques” – described by the ECHR as methods of “disorientation” or “sensory deprivation” – include a number of practices allegedly being used today by U.S. interrogators:

- Wall-standing: Forcing a detainee to remain spread-eagled against a wall with his fingers placed high above his head against the wall, his legs spread apart and his feet positioned such that he must stand on his toes with the weight of his body resting on his fingers;

¹⁶⁶ *The Republic of Ireland v. The United Kingdom*, (1979-80) 2 E.H.R.R. 25.

¹⁶⁷ *Id.*, at 30-31.

¹⁶⁸ *Id.*, at 36.

¹⁶⁹ *Id.*, at 25.

- Hooding: Keeping a dark bag over a detainee’s head at all times, except during interrogation;
- Subjection to noise: Holding a detainee in a room where there is a continuous loud and hissing noise;
- Deprivation of sleep; and
- Deprivation of food and drink.¹⁷⁰

The European Commission of Human Rights unanimously found that the “five techniques” constituted torture, and that other challenged interrogation practices amounted to inhuman and degrading treatment.¹⁷¹ Although the British Government subsequently discontinued the “five techniques” and did not contest the underlying allegations of the case or the Commission’s findings in connection therewith, the Republic of Ireland nevertheless referred the case to the ECHR.¹⁷² The ECHR took the opportunity to rule upon the legality of the “five techniques,” citing to the European Court’s responsibility “to elucidate, safeguard and develop the rules instituted by the Convention.”¹⁷³

In *The Republic of Ireland* decision, the ECHR explained that ill-treatment “had to attain a minimum level of severity to fall within Article 3, the assessment of which was necessarily relative, depending on all the circumstances, including the duration of the treatment, its physical or mental effects and, sometimes, the sex, age or state of health of the victim.”¹⁷⁴ The ECHR pointed out that, while the term “torture” attached “a special stigma to deliberate inhuman treatment causing very serious and cruel suffering,” the distinction between torture and

¹⁷⁰ *Id.*, at 59.

¹⁷¹ *Id.*, at 25.

¹⁷² *Id.*, at 25.

¹⁷³ *Id.*, at 75-76.

¹⁷⁴ *Id.*, at 26.

inhuman or degrading treatment “derived principally from a difference in the intensity of the suffering inflicted.”¹⁷⁵ The ECHR held that since the “five techniques” “were applied in combination, with premeditation and for hours at a time, causing at least intense physical and mental suffering and acute psychiatric disturbances, they amount to inhuman treatment.”¹⁷⁶ The ECHR further held that since the “five techniques” aroused “in the victims feelings of fear, anguish and inferiority capable of humiliating and debasing them and possibly breaking their physical or moral resistance, they were also degrading.”¹⁷⁷ The ECHR concluded that the “five techniques” violated Article 3’s prohibition against inhuman or degrading treatment, but that they did not amount to torture.¹⁷⁸

¹⁷⁵ *Id.*, at 26.

¹⁷⁶ *Id.*, at 26.

¹⁷⁷ *Id.*

¹⁷⁸ *Id.*, at 79-80. In separate annexed opinions, Judges Zekia, O’Donoghue and Evrigenis disagreed with the majority’s ruling that the five practices did not amount to torture.

In the years since the *Republic of Ireland* decision, neither time nor the ever-expanding threat of terrorism has diminished the ECHR’s commitment to maintaining an absolute prohibition against torture and inhuman or degrading treatment. In *Chahal v. United Kingdom*, Case No. 70/1995/576/662 (Nov. 15, 1996), for example, the ECHR rejected Great Britain’s argument that national security considerations justified the deportation of an Indian citizen to India on grounds that he was active in extremist Sikh organizations in England and was suspected of planning terrorist and other violent acts in the country. Chahal argued that, if deported, he would be tortured in India. In ruling that Chahal’s deportation by the United Kingdom would constitute a violation of Article 3 of the Convention, the ECHR stated:

Article 3 enshrines one of the most fundamental values of democratic society. . . . The Court is well aware of the immense difficulties faced by States in modern times in protecting their communities from terrorist violence. However, even in these circumstances, the Convention prohibits in absolute terms torture or inhuman or degrading treatment or punishment, irrespective of the victim’s conduct. Unlike most of the substantive clauses of the Convention and of Protocols Nos. 1 and 4, Article 3 makes no

*Israeli Supreme Court Judgment Concerning The Legality
Of The General Security Service's Interrogation Methods*
As the Israeli Supreme Court notes at the outset of its *Judgment Concerning The*

Legality Of The General Security Service's Interrogation Methods,¹⁷⁹ the State of Israel "has been engaged in an unceasing struggle for both its very existence and security, from the day of its founding":

Terrorist organizations have established as their goal Israel's annihilation. Terrorist acts and the general disruption of order are their means of choice. In employing such methods, these groups do not distinguish between civilian and military targets. They carry out terrorist attacks in which scores are murdered in public areas, public transportation, city squares and centers, theaters and coffee shops. They do not distinguish between men, women and children. They act of cruelty and without mercy.¹⁸⁰

In 1987, the Landau Commission of Inquiry into the Methods of Investigation of the GSS Regarding Hostile Terrorist Acts (the "Landau Commission") was established to investigate the interrogation practices of the main body responsible for fighting terrorism in Israel, the General Security Service (the "GSS"), and to reach legal conclusions concerning them. The resulting Landau Report,¹⁸¹ concluded: "The effective interrogation of terrorist suspects is impossible without the use of means of pressure, in order to overcome an obdurate

provision for exceptions and no derogation from it is permissible under Article 15 even in the event of a public emergency threatening the life of the nation.

Id., at 79. See also *Aksoy v. Turkey*, Case No. 100/1995/606/694 (Dec. 15, 1996), para. 62 (ruling that Turkish security forces' treatment of a detainee suspected of membership and activity on behalf of the PKK, a Kurdish militant organization operating against the Turkish government, constituted torture).

¹⁷⁹ *Judgment Concerning The Legality Of The General Security Service's Interrogation Methods*, 38 I.L.M. 1471 (Sept. 9, 1999) (the "GSS Interrogation Methods Decision").

¹⁸⁰ *Id.*, at 1472.

¹⁸¹ Excerpts printed in 23 Isr. L. Rev. 146 (1989).

will not to disclose information and to overcome the fear of the person under interrogation that harm will befall him from his own organization, if he does not reveal information.”¹⁸² The Landau Report explained that: “The means of pressure should principally take the form of non-violent psychological pressure through a vigorous and extensive interrogation, with the use of stratagems, including acts of deception. However, when these do not attain their purpose, the exertion of a moderate measure of physical pressure cannot be avoided.”¹⁸³ The Landau Commission recommended, however, that GSS interrogators should be guided by clear rules “to prevent the use of inordinate physical pressure arbitrarily administered,” and formulated a code of guidelines (set forth in a secret part of the Landau Report) which defined, “on the basis of past experience, and with as much precision as possible, the boundaries of what is permitted to the interrogator and mainly what is prohibited to him.”¹⁸⁴ The Landau Commission asserted that the latitude it afforded GSS interrogators to use “a moderate measure of physical pressure” did not conflict with the standards set forth in international human rights conventions – such as the UDHR, the ICCPR and the European Convention – which prohibited torture and cruel, inhuman or degrading treatment or punishment.¹⁸⁵

In 1999, in the *GSS Interrogation Methods Decision*, the Israeli Supreme Court took up the legality of certain interrogation practices employed by the GSS. The Israeli Supreme Court acknowledged that the Landau Commission had approved the use of “a moderate degree of physical pressure,” and that the Landau Commission’s recommendations had been accepted by

¹⁸² *Id.*, at 184.

¹⁸³ *Id.*

¹⁸⁴ *Id.*, at 185.

¹⁸⁵ *Id.*, at 186.

the Israeli Government.¹⁸⁶ The interrogation methods considered by the Israeli Supreme Court in the *GSS Interrogation Methods Decision* were:

- Shaking: Forcefully shaking a detainee's upper torso back and forth, repeatedly, and in a manner which causes the neck and head to dangle and vacillate rapidly.
- The "shabach" position: Forcing a detainee who has his hands tied behind his back to sit on a small and low chair whose seat is tilted forward and towards the ground, where one hand is placed inside the gap between the chair's seat and back support, the detainee's head is covered by an opaque sack falling down to his shoulders, and powerfully loud music is played in the room.
- The "frog crouch": Forcing a detainee to crouch on the tips of his/her toes for five minute intervals.
- Excessive tightening of handcuffs: Using particularly small cuffs, ill-fitted in relation to the suspect's arm or leg size.
- Sleep deprivation: A detainee is deprived of sleep as a result of being tied in the "shabach" position, being subjected to powerfully loud music or intense non-stop interrogations.¹⁸⁷

In examining the legality of these GSS interrogation methods, the Israeli Supreme Court acknowledged that, taken individually, some of the components of the "shabach" position have "legitimate" goals: for example, hooding prevents communication between suspects, the playing of powerfully loud music prevents the passing of information between suspects, the tying of the suspect's hands to a chair protects investigators, and the deprivation of sleep can be

¹⁸⁶ *GSS Interrogation Methods Decision*, 38 I.L.M. at 1477.

¹⁸⁷ *Id.*, at 1474 -76. The Israeli Government argued that such interrogation methods did not need to be outlawed because, before resorting to physical pressure against detainees, GSS interrogators are instructed to "probe the severity of the danger that the interrogation is intending to prevent; consider the urgency of uncovering the information presumably possessed by the suspect in question; and seek an alternative means of preventing the danger." *Id.*, at 1475. The Israeli Government also argued that directives respecting interrogation provide that in cases where shaking – considered the harshest interrogation method of those examined in the *GSS Interrogation Methods Decision* – is to be used, "the investigator must first provide an evaluation of the suspect's health and ensure that no harm comes to him." *Id.*, at 1475.

necessitated by an interrogation.¹⁸⁸ According to the Israeli Supreme Court, however, there is a necessary balancing process between a government's duty to ensure that human rights are protected and its duty to fight terrorism. The results of that balance, the Israeli Supreme Court stated, are the rules for a "reasonable interrogation" – defined as an interrogation which is: (1) "necessarily one free of torture, free of cruel, inhuman treatment of the subject and free of any degrading handling whatsoever"; and (2) "likely to cause discomfort."¹⁸⁹ "In the end result," the Court noted, "the legality of an investigation is deduced from the propriety of its purpose and from its methods."¹⁹⁰

Turning to the specific interrogation methods before it, the Court concluded that shaking, the "frog crouch," the "shabach" position, cuffing causing pain, hooding, the consecutive playing of powerfully loud music and the intentional deprivation of sleep for a prolonged period of time are all prohibited interrogation methods.¹⁹¹ "All these methods do not fall within the sphere of a 'fair' interrogation. They are not reasonable. They impinge upon the suspect's dignity, his bodily integrity and his basic rights in an excessive manner (or beyond what is necessary). They are not to be deemed as included within the general power to conduct interrogations."¹⁹² The Israeli Supreme Court explained that restrictions applicable to police investigations are equally applicable to GSS investigations, and that there are no grounds to

¹⁸⁸ *Id.*, at 1480 - 81.

¹⁸⁹ *Id.*, at 1482.

¹⁹⁰ *Id.*

¹⁹¹ *Id.*, at 1482-84.

¹⁹² *Id.*, at 1483.

permit GSS interrogators to engage in conduct which would be prohibited in a regular police interrogation.¹⁹³

In so ruling, the Israeli Supreme Court considered the “ticking time bomb” scenario often confronted by GSS interrogators:

A given suspect is arrested by the GSS. He holds information respecting the location of a bomb that was set and will imminently explode. There is no way to defuse the bomb without this information. If the information is obtained, however, the bomb may be defused. If the bomb is not defused, scores will be killed and maimed. Is a GSS investigator authorized to employ physical means in order to elicit information regarding the location of the bomb in such instances?¹⁹⁴

The Israeli Supreme Court stated that it was prepared to presume that if a GSS investigator – who applied physical interrogation methods for the purpose of saving human life – is criminally indicted, the “necessity” defense recognized under Israeli Penal Law would be open to him in the appropriate circumstances.¹⁹⁵ The Israeli Supreme Court also acknowledged that the legislature could enact laws permitting the interrogation methods that its decision struck down.¹⁹⁶ However, the Israeli Supreme Court refused to imply from the existence of the “necessity” defense, as the State argued for it to do, “an advance legal authorization endowing the investigator with the capacity to use physical interrogation methods.”¹⁹⁷

¹⁹³ *Id.*, at 1485.

¹⁹⁴ *Id.*

¹⁹⁵ *Id.*, at 1486.

¹⁹⁶ *Id.*, at 1487.

¹⁹⁷ *Id.*, at 1486.

The Legal and Moral Implications of the “Ticking Bomb” Scenario
 As the *Republic of Ireland* and *GSS Interrogation Methods Decision* demonstrate,

in the face of a terrorist threat there is an inherent tension between obtaining potentially life-saving intelligence information through abusive interrogation of detainees and upholding human rights:

In crystallizing the interrogation rules, two values or interests clash. On the one hand, lies the desire to uncover the truth, thereby fulfilling the public interest in exposing crime and preventing it. On the other hand, is the wish to protect the dignity and liberty of the individual being interrogated.¹⁹⁸

International and human rights law is clear: torture and cruel, inhuman or degrading treatment of detainees is prohibited. Those who would, nevertheless, support the use of moderate physical force, sensory deprivation or disorientation techniques in the interrogation of terrorist suspects argue that resort to such methods is, at times, the only way to prevent the death of innocent persons and is, therefore, justified in such cases as the “lesser of two evils.” Proponents of this view would argue that the legitimacy of an act can be measured by whether its utility exceeds its harm. On this point, the Landau Commission took the following position:

To put it bluntly, the alternative is: are we to accept the offense of assault entailed in slapping a suspect’s face, or threatening him, in order to induce him to talk and reveal a cache of explosive materials meant for use in carrying out an act of mass terror against a civilian population, and thereby prevent the greater evil which is about to occur? The answer is self-evident.

Everything depends on weighing the two evils against each other.¹⁹⁹

In the case of detainees being held by the U.S. in connection with the “War on Terror,” however, the “ticking bomb” scenario is further complicated. Any utilitarian

¹⁹⁸ *Id.*, at 1481.

¹⁹⁹ *See* 23 *Isr. L. Rev.*, at 174.

justification for subjecting these detainees to interrogation practices prohibited by CAT must necessarily be premised on the certainty (or, at least, the substantiated suspicion) that these individuals do, in fact, possess vital intelligence information. But, here, there is no such certainty. Instead, hundreds of detainees at Guantánamo Bay, Bagram Air Force Base and other U.S. detention facilities have been detained for months without any type of hearing or legal challenge permitted to their detention.

Our answer to the question of whether torture of detainees should ever be permitted in a post-September 11 world is that there are no such circumstances. We condemn the use of torture in interrogation of detainees, without exception. By its terms, CAT permits no derogation of the prohibition against torture – stating that “[n]o exceptional circumstances whatsoever, whether a state of war or a threat of war, internal political stability or any other public emergency, may be invoked as a justification of torture.”²⁰⁰ As the Israeli Supreme Court has explained, “A democratic, freedom-loving society does not accept that investigators use any means for the purpose of uncovering the truth. ‘The interrogations practices of the police in a given regime are indicative of a regime’s very character.’”²⁰¹

We recognize that some legal scholars and ethicists may well argue that circumstances exist (as in the “ticking bomb” scenario) in which torture and CID treatment in the interrogation of detainees should be permitted. However, we stress that torture of detainees – which is prohibited under international and U.S. law – is never permissible, and should be fully investigated and prosecuted in all cases.

* * *

²⁰⁰ CAT, Art. 2.

²⁰¹ *GSS Interrogation Methods Decision*, 38 I.L.M. at 1481 (internal citations omitted).

In summary, the Association makes the following recommendations:

First, we urge the United States to amend 18 U.S.C. § 2340 to encompass the actions of military and intelligence personnel at U.S. facilities overseas, to fully utilize the UCMJ to protect all detainees from abuse and to independently investigate human rights compliance in countries to which we are “rendering” detainees.

Second, U.S. military and intelligence personnel involved in interrogation of terrorist suspects should be educated regarding the prohibition against torture and CID, and should receive training to comply with those rules.

Third, the U.S. should adhere to its commitments under the Geneva Conventions, extend POW treatment to regular force combatants as a matter of policy, and promptly establish proper screening procedures and hearings for all detainees.

Finally, the Association notes that particularly in these times of terrorism and violence, it is important to protect the rule of law and the standards of decency to which our nation and the community of nations are committed. As the Israeli Supreme Court has stated:

This is the destiny of democracy, as not all means are acceptable to it, and not all practices employed by its enemies are open before it. Although a democracy must often fight with one hand tied behind its back, it nonetheless has the upper hand.²⁰²

* * *

²⁰² *Id.*, at 1488.

Table of Contents

	Page
Executive Summary/Introduction	1
I. THE CONVENTION AGAINST TORTURE	13
A. CAT's Definitions of – and Prohibitions against – Torture and Cruel, Inhuman or Degrading Treatment	14
B. CAT's Prohibition against Torture and CID Treatment as Interpreted by the U.N. Committee Against Torture	16
C. U.S. Law Implementing CAT's Prohibitions against Torture and Cruel, Inhuman or Degrading Treatment or Punishment	19
1. U.S. Understandings and Reservations in Ratifying CAT	20
2. The Implementation of CAT's Prohibition against Torture in U.S. Legislation, Regulation and Case Law	21
(a) U.S. Immigration Law and Torture	22
(b) U.S. Extradition of Fugitives Who Face Threat of Torture	23
(c) U.S. Implementation of CAT's Criminal Law Requirements	24
(d) U.S. Case Law Interpretations of Torture in Tort Claims	25
(e) Conclusion: CAT's Prohibition against Torture as Implemented in U.S. Legislation and Regulation	26
3. CAT's Prohibition against "Cruel, Inhuman or Degrading Treatment," as Interpreted by United States Law	26
(a) Fifth and Fourteenth Amendment Standards	27
(b) Eighth Amendment Standards	28
D. Enforcement of CAT under U.S. Law	30
1. 18 U.S.C. §§ 2340 – 2340B	30
2. Uniform Code of Military Justice	32
E. Summary	38
II. THE GENEVA CONVENTIONS	39
A. Application of the Geneva Conventions to the Afghan Conflict Generally	43
B. Geneva III	43
1. Relevant Legal Standards	43
2. The United States' Position	46
3. Critiques of the United States' Position	48
(a) Article 5 Presumes POW Status Until the Determination of Status by a Competent Tribunal	50
(b) The Taliban Detainees Were "Regular Armed Forces" and, therefore, Are Encompassed by Article 4(A) of Geneva III	51
(c) Policy Arguments Favoring Broad Grant of POW Status to Non-Civilian Detainees from the War in Afghanistan	51

C.	Geneva IV	53
D.	Summary	56
III. OTHER INTERNATIONAL LEGAL STANDARDS 57		
A.	The International Covenant on Civil and Political Rights	57
1.	Relevant Legal Standards	57
2.	Enforcement	59
	(a) U.S. Courts	59
	(b) The Human Rights Committee	60
B.	Organization of American States' Instruments	60
1.	Relevant Legal Standards	60
2.	Enforcement	65
C.	Customary International Law and <i>Jus Cogens</i>	68
1.	Relevant Legal Standards	68
2.	Enforcement	72
IV. SHOULD EXCEPTIONS BE MADE FOR THE "WAR ON TERROR"?: THE EXPERIENCE OF OTHER JURISDICTIONS 72		
A.	Legal Challenges to Interrogation Practices in Northern Ireland and Israel	73
1.	<i>The Republic of Ireland v. The United Kingdom</i>	73
2.	Israeli Supreme Court <i>Judgment Concerning The Legality Of The General Security Service's Interrogation Methods</i>	77
B.	The Legal and Moral Implications of the "Ticking Bomb" Scenario	82

The Committee on International Human Rights

Martin S. Flaherty, Chair*
 Scott Horton (Immediate Past Chair)*
 Jeanmarie Fenrich, Secretary

Charles Adler
 Patricia C. Armstrong
 Hon. Deborah A. Batts
 Nicole Barrett
 Aarthi Belani (student member)*
 Seymour H. Chalif
 Amy Christina Cococcia
 Catherine Daly
 Eric O. Darko
 Jane M. Desnoyers
 Mark K. Dietrich
 Fiona M. Doherty
 Barbara Fortson (former member)*
 Aya Fujimura-Fanselow (student member)
 Douglas C. Gray
 William M. Heinzen
 Alice H. Henkin
 Sharon K. Hom
 Miranda Johnson (student member)
 Anil Kalhan
 Mamta Kaushal
 Christopher Kean
 Elise B. Keppler
 Katharine Lauer*
 Sara Lesch
 Yvonne C. Lodico
 Marko C. Maglich
 Elisabeth Adams Mason
 Nina Massen
 Sam Scott Miller
 Elena Dana Neacsu
 Dyanna C. Pepitone
 Marny Requa (student member)
 Sidney S. Rosdeitcher**
 Margaret L. Satterthwaite*
 Joseph H. Saunders
 Christopher A. Smith (student member)
 Katherine B. Wilmore

The Committee on Military Affairs and Justice

Miles P. Fischer, Chair*
Michael Mermin, Secretary

Donna Ahlstrand (former member)*

Steven Barrett
Myles Bartley
Philip Blum
Kenneth Carroll
Brian Cogan
Joshua Eisenberg
Matthew Hawkins
Peter Jaensch
Peter Kornman
Peter Langrind
Gerald Lee
Patricia Murphy
Rose Murphy
Harold Nathan
Timothy Pastore
Stanley Paylago*
Visuvanathan Rudrakumaran
Lawrence Sloan

* Members of the Subcommittee who prepared the report.

** Chair of the Subcommittee responsible for preparing the report.

The views expressed herein are solely those of the Association and the participating Committees.

The Committee on International Human Rights and Military Affairs and Justice would like to thank the following persons for their assistance in the preparation of the report: John Cerone (Executive Director, War Crimes Research Office, Washington College of Law, American University); Ken Hurwitz (Human Rights First); Professor Marco Sassòli (University of Geneva, professor of international law); Brigitte Oederlin and Gabor Rona (International Committee of the Red Cross); Paul, Weiss, Rifkind, Wharton & Garrison LLP ("Paul Weiss") associates Katarina Lawergren and Marc Miller and former Paul Weiss associate Matias Milet; and New York University School of Law students Ari Bassin, Amber A. Baylor, Angelina Fisher, Tzung-lin Fu, David R. Hoffman, Jane Stratton and Stephanie S. Welch; and New York Law School student Holly Higgins. This report could not have been completed without the indefatigable efforts of Paul Weiss associate Liza Velazquez in helping edit the many drafts of the Report and consolidating the many views and comments of the Committees and Subcommittee into a coherent whole.

Appendix A

December 26, 2002

President George W. Bush

The White House

1600 Pennsylvania Avenue, NW

Washington, DC 20500

Dear President Bush:

Human Rights Watch is deeply concerned by allegations of torture and other mistreatment of suspected al-Qaeda detainees described in the Washington Post ("U.S. Denies Abuse but Defends Interrogations") on December 26. The allegations, if true, would place the United States in violation of some of the most fundamental prohibitions of international human rights law. Any U.S. government official who is directly involved or complicit in the torture or mistreatment of detainees, including any official who knowingly acquiesces in the commission of such acts, would be subject to prosecution worldwide.

Human Rights Watch urges you to take immediate steps to clarify that the use of torture is not U.S. policy, investigate the Washington Post's allegations, adopt all necessary measures to end any ongoing violations of international law, stop the rendition of detainees to countries where they are likely to be tortured, and prosecute those implicated in such abuse.

f. Prohibitions Against Torture

The Washington Post reports that persons held in the CIA interrogation centers at Bagram air base in Afghanistan are subject to "stress and duress" techniques, including "standing or kneeling for hours" and being "held in awkward, painful positions." The Post notes that the detention facilities at Bagram and elsewhere, such as at Diego Garcia, are not monitored by the International Committee of the Red Cross, which has monitored the U.S. treatment of detainees at Guantánamo Bay, Cuba.

The absolute prohibition against torture is a fundamental and well-established precept of customary and conventional international law. Torture is never permissible against anyone, whether in times of peace or of war.

The prohibition against torture is firmly established under international human rights law. It is prohibited by various treaties to which the United States is a party, including the International Covenant on Civil and Political Rights (ICCPR), which the United States ratified in 1992, and the Convention against Torture and Other Cruel, Inhuman or Degrading Treatment or Punishment, which the United States ratified in 1994. Article 7 of the ICCPR states that "No one shall be subjected to torture or to cruel, inhuman or degrading treatment or punishment." The right to be protected from torture is non-derogable, meaning that it applies at all times, including during public emergencies or wartime.

International humanitarian law (the laws of war), which applies during armed conflict, prohibits the torture or other mistreatment of captured combatants and others in captivity, regardless of their legal status. Regarding prisoners-of-war, article 17 of the Third Geneva Convention of 1949 states: "No physical or mental torture, nor any other form of coercion, may be inflicted on prisoners of war to secure from them information of any kind whatever. Prisoners of war who refuse to answer may not be threatened, insulted, or exposed to any unpleasant or disadvantageous treatment of any kind." Detained civilians are similarly protected by article 32 of the Fourth Geneva Convention. The United States has been a party to the 1949 Geneva Conventions since 1955.

The United States does not recognize captured al-Qaeda members as being protected by the 1949 Geneva Conventions, although Bush administration officials have insisted that detainees will be treated humanely and in a manner consistent with Geneva principles. However, at minimum, all detainees in wartime, regardless of their legal status, are protected by customary international humanitarian law. Article 76 ("Fundamental Guarantees") of the First Additional Protocol to the Geneva Conventions, which is recognized as restating customary international law, provides that "torture of all kinds, whether physical or mental" against "persons who are in the power of a

Party to the conflict and who do not benefit from more favorable treatment under the [Geneva] Conventions," shall "remain prohibited at any time and in any place whatsoever, whether committed by civilian or military agents." "[C]ruel treatment and torture" of detainees is also prohibited under common article 3 to the 1949 Geneva Conventions, which is considered indicative of customary international law.

II. Possible U.S. Complicity in Torture

It is a violation of international law not only to use torture directly, but also to be complicit in torture committed by other governments. The Post reports being told by U.S. officials that "[t]housands have been arrested and held with U.S. assistance in countries known for brutal treatment of prisoners." The Convention against Torture provides in article 4 that all acts of torture, including "an act by any person which constitutes complicity or participation in torture," is an offense "punishable by appropriate penalties which take into account their grave nature."

The Post article describes the rendition of captured al-Qaeda suspects from U.S. custody to other countries where they are tortured or otherwise mistreated. This might also be a violation of the Convention against Torture, which in article 3 states: "No State Party shall expel, return ('refouler') or extradite a person to another State where there are substantial grounds for believing that he would be in danger of being subjected to torture.... For the purpose of determining whether there are such grounds, the competent authorities shall take into account all relevant considerations including, where applicable, the existence in the State concerned of a consistent pattern of gross, flagrant or mass violations of human rights."

The U.S. Department of State annual report on human rights practices has frequently criticized torture in countries where detainees may have been sent. These include Uzbekistan, Pakistan, Egypt, Jordan and Morocco. The United States thus could not plausibly claim that it was unaware of the problem of torture in these countries.

III. International Prosecutions for Torture and Command Responsibility

Direct involvement or complicity in torture, as well as the failure to prevent torture, may subject U.S. officials to prosecution under international law.

The willful torture or inhuman treatment of prisoners-of-war or other detainees, including "willfully causing great suffering or serious injury to body or health," are "grave breaches" of the 1949 Geneva Conventions, commonly known as war crimes. Grave breaches are subject to universal jurisdiction, meaning that they can be prosecuted in any national criminal court and as well as any international tribunal with appropriate jurisdiction.

The Convention against Torture obligates States Parties to prosecute persons within their jurisdiction who are implicated or complicit in acts of torture. This obligation includes the prosecution of persons within their territory who committed acts of torture elsewhere and have not been extradited under procedures provided in the convention.

Should senior U.S. officials become aware of acts of torture by their subordinates and fail to take immediate and effective steps to end such practices, they too could be found criminally liable under international law. The responsibility of superior officers for atrocities by their subordinates is commonly known as command responsibility. Although the concept originated in military law, it now is increasingly accepted to include the responsibility of civil authorities for abuses committed by persons under their direct authority. The doctrine of command responsibility has been upheld in recent decisions by the international criminal tribunals for the former Yugoslavia and for Rwanda.

There are two forms of command responsibility: direct responsibility for orders that are unlawful and imputed responsibility, when a superior knows or should have known of crimes committed by a subordinate acting on his own initiative and fails to prevent or punish them. All states are obliged to bring such people to justice.

The allegations made by the Washington Post are extraordinarily serious. They have put the United States on notice that acts of torture may be taking place with U.S. participation or complicity. That creates a heightened duty

to respond preventively. As an immediate step, we urge that you issue a presidential statement clarifying that it is contrary to U.S. policy to use or facilitate torture. The Post's allegations should be investigated and the findings made public. Should there be evidence of U.S. civilian or military officials being directly involved or complicit in torture, or in the rendition of persons to places where they are likely to be tortured, you should take immediate steps to prevent the commission of such acts and to prosecute the individuals who have ordered, organized, condoned, or carried them out. The United States also has a duty to refrain from sending persons to other countries with a history of torture without explicit and verifiable guarantees that no torture or mistreatment will occur.

Thank you for your attention to these concerns.

Sincerely,

Kenneth Roth

Executive Director

Cc: Colin Powell, Secretary of State

Donald Rumsfeld, Secretary of Defense

Condoleezza Rice, National Security Advisor

January 31, 2003

The Honorable George W. Bush
The White House
Washington, DC 20301-1010

Dear President Bush:

We are writing to you on a matter of great concern. As you are no doubt aware, on December 26th the Washington Post reported that your Administration has used, tacitly condoned or facilitated torture by third countries in the interrogation of prisoners. These reports are so flagrantly at odds with your many statements about the importance of human rights that we trust that you are equally disturbed by it.

You have repeatedly declared that the United States "will always stand firm for the non-negotiable demands of human dignity." Surely there is no more basic and less negotiable requirement of human dignity than the right to be free of torture or cruel, inhuman or degrading treatment. As you know, under the Torture Convention "no exceptional circumstances whatsoever" may be invoked to justify torture and no party may return or extradite a person to another state where there are "substantial grounds for believing that he would be in danger of being subjected to torture." Likewise, under the Covenant on Civil and Political Rights, "no one shall be subjected to torture or to cruel, inhuman or degrading treatment or punishment."

As you declared in your State of the Union address, these solemn commitments of the United States are non-negotiable; in legal terms, there can be no derogation from them. You may also know that it was your father's Administration that sought and received overwhelming Senate support for the United States to ratify these two treaties.

The Administration's response to the outrageous statements made by numerous unnamed officials to the Post's reporters concerning United States use or tolerance of torture and cruel, inhuman and degrading treatment has thus far been wholly inadequate. Whatever the truth of the Post's allegations, without a more authoritative response to this high-profile story the world will conclude that the United States is not practicing what it preaches. America's authority as a champion of human rights will be seriously damaged.

What is clearly needed in this instance are unequivocal statements by you and your Cabinet officers that torture in any form or manner will not be tolerated by this Administration, that any US official found to have used or condoned torture will be held accountable, and that the United States would neither seek nor rely upon intelligence obtained through torture in a third country. These statements need to be accompanied by clear written guidance applicable to everyone engaged in the interrogation and rendition of prisoners strictly prohibiting the use or tolerance of torture or cruel, inhuman or

degrading treatment of prisoners and mandating full compliance with the Geneva conventions requirements for the treatment of prisoners.

We urge you in the strongest terms to take this opportunity to demonstrate that torture and cruel, inhuman and degrading treatment is, in fact as well as word, non-negotiable.

Sincerely,

William Schulz
Amnesty International USA

Kenneth Roth
Human Rights Watch

Gay McDougall
International Human Rights Law Group

Louise Kantrow
International League for Human Rights

Michael Posner
Lawyers Committee for Human Rights

Robin Phillips
Minnesota Advocates for Human Rights

Len Rubenstein
Physicians for Human Rights

Todd Howland
RFK Memorial Center for Human Rights

Senator KENNEDY. Now, do you know anything, General Romig, about any of your officers in the DOD being concerned about these issues?

General ROMIG. Sir, first, I received both of these articles from one of your staffers immediately—

Senator KENNEDY. I wanted you to know it before I asked you the question.

General ROMIG. Yes, sir. I appreciate that.

I also contacted my office immediately and said, "Let's get to the bottom of this and find out"—for one thing, I can't tell, really—and I skimmed through the articles—if these are Army JAGs, Air Force JAGs, Navy JAGs, or Marine JAGs. It's troubling, regardless of who said it, but we're trying to get to the bottom of it.

Senator KENNEDY. Do you know whether they—any of these safeguards had been removed with regard to these prisons, such as the two-way mirror? Have there been changes? Have there been alternatives for what—a process where JAG had been monitoring, watching, or observing these kinds of interrogations?

General ROMIG. Sir, I'm not aware of the use of the two-way mirror as a regular standard method of monitoring interrogations. The fact that there are so many interrogations going on at different locations, we wouldn't have enough JAG officers to sit through all of these.

Senator KENNEDY. Do you know if there's been a change? Here is—"Mr. Horton and the bar colleagues wrote to Haynes and the

CIA's general counsel in an effort to clarify U.S. policy on the treatment and interrogation of detainees. "These inquiries," he recalls, "were met with a firm brush-off. We then turned to Senators who have raised the issue previously, and assisted their staff in pursuing it. These inquiries were met with a similar brush-off."

What do you know about any of the changes that have taken place with regards to the JAG position, in terms of observing the interrogation of detainees, POW, combat—

General ROMIG. Sir, I'm not aware of any change in that regard.

Senator KENNEDY. That has not been brought at all to your attention in the—

General ROMIG. Not the issue of the role of the JAG in the—

Senator KENNEDY. No one in your department has come to you and expressed any kind of concern that they had heard that there were these kinds of activities, inappropriate kinds of activities taking place in any of the prisons? I have to move along. Either yes or no.

General ROMIG. Sir, I'm not aware of anybody specifically talking about any issues in a prison who have looked into those.

Senator KENNEDY. With regard to the contractors, as I understand, the Uniform Code of Military Justice (UCMJ) doesn't apply to the contractors, does it?

General ROMIG. Sir, technically it would in a congressionally-declared war. Article 2 of the UCMJ—

Senator KENNEDY. In the kind of situation we have now, it does not.

General ROMIG. It does not, that is correct.

Senator KENNEDY. All right. What about the Status of Forces Agreement (SOFA)? I understand we have a SOFA that excludes prosecution for the military, also civilian personnel.

General ROMIG. It depends on which SOFA we're talking about, sir.

Senator KENNEDY. I'm talking about those that are applicable. We're talking about Iraq, and we're talking about Afghanistan. If there are other places you want to distinguish you can do that.

General ROMIG. Yes, sir. Basically, my understanding right now is that we do not have a SOFA in Iraq because we are in a mode where we are really operating the sovereignty there. But once it's turned over, that'll be one of the issues that we must have, is a SOFA.

Now, there is another piece of legislation that I think you're aware of—

Senator KENNEDY. That's going to happen pretty quickly.

General ROMIG. Yes, sir.

Senator KENNEDY. Give me, quickly, the answer in Afghanistan, so I know that. Can they be prosecuted? Will civilians be protected under the SOFA?

General ROMIG. Again, it depends on the kind of offense, but my understanding is that we would have jurisdiction over those.

Senator KENNEDY. Homicide.

General ROMIG. Homicide—

Senator KENNEDY. There are two individuals—

General ROMIG.—U.S. on U.S., we'd have jurisdiction.

Senator KENNEDY. You'd have jurisdiction.

Let me just, finally, ask General Alexander, what's going to be the status of these camps on June—at the time of the transfer of sovereignty? Who's taking them over? Is the United States still going to be running these camps? Is it going to be the Iraqis? Tell us what exactly is going to be the status in these prison camps in Iraq.

General ALEXANDER. Sir, I'm not sure of what the status is going to be of those camps. I believe that we will still run some of those camps. I know that when General Ryder went over, one of his issues was to figure out when the Iraqis would be capable of running the camps, the prison system, themselves. I'm not sure what the status is, sir. I'd have to take that for the record.

[The information referred to follows:]

At the time of the transfer of sovereignty, all detainee facilities will remain under the operational control of U.S. military forces.

Senator KENNEDY. My time is up.

Senator INHOFE [presiding]. Thank you, Senator Kennedy.

Senator Roberts has an Intelligence Committee commitment, so I'm going to defer to him and then take his turn, without objection.

Senator ROBERTS. I thank the Senator, and I will try to be very brief. I think many of the questions, while important, are a little repetitive.

This is a question for General Romig. There has been a great deal of discussion about the fact that the MI brigade at the prison was given TACON of the MP unit there. Now, given the fact that the abuse at issue is a violation of the UCMJ, what impact does the issue of TACON have on the culpability of those who have committed these acts?

General ROMIG. Virtually none, sir. If you commit an offense under the code, regardless of what the chain of command is, charges can be preferred, and they would go up to the general court-martial convening authority—or the special court-martial convening authority, but if it's serious offenses, it would go up to the general court-martial convening authority, which would probably be either III Corps or CJTF-7.

Senator ROBERTS. The same question I asked this morning, and a related question—an order to “soften up” a detainee would not be a lawful order, is that correct?

General ROMIG. That's exactly right, sir, depending on how it was conveyed. But on its face, it does not sound like a lawful order.

Senator ROBERTS. So what legal basis, then, would a soldier have for following that order?

General ROMIG. Sir, there would be none. Our soldiers are taught, “Illegal orders are orders that you first must, or should, apprise the person giving the order that it's an illegal order, and, if they don't cease and desist, then you must disobey.”

Senator ROBERTS. General Alexander, I know you went over, in some detail, who had the accountability and the responsibility on the lack of training and the lack of leadership and the lack of discipline. Who had the responsibility to ensure the MPs were properly trained and were actually fulfilling the unit's mission? Are we talking about Colonel Pappas or Lieutenant Colonel Jordan or General Karpinski? Who is it?

General ALEXANDER. General Karpinski and Colonel Phillabaum, sir.

Senator ROBERTS. And Colonel Phillabaum.

General ALEXANDER. The battalion commander.

Senator ROBERTS. Okay. Let me just say that—for the record, and I hesitate doing this, but I think it's pertinent to what has been discussed by Senator McCain—there's just been a video posted on an Islamic militant Web site showing a group affiliated with al Qaeda that beheaded an American civilian in Iraq, saying the death was revenge for the abuse of the prisoners by American soldiers. I will not get into the individual's name. After reading the statement, the men were seen pulling the man to his side, and putting a large knife to his neck, a scream sounded as the men literally cut off his head, shouting, "Allah akbar," God is great, and then held the head out before the camera.

It seems to me that this underscores, in part at least, the tremendous value of interrogation and better intelligence to prevent atrocities like this. I don't think this was a one-for-one cause. In other words, I think this happens anyway, under the circumstances. But there's a different value system going on here. I know we have to reach—for the very highest levels of conduct, and I know we will. I know as soon as we get through with the inquiry—or the investigation, pardon me—the Fay Report—that you'll report back to the Intelligence Committee and this committee on what happened.

I mention that only to show that this is a very difficult situation, and, under the circumstances, I think that the American public certainly understands that.

I thank the Senator for yielding me the time.

Senator INHOFE. Thank you, Senator.

Senator Byrd.

Senator BYRD. Thank you, Mr. Chairman.

The ICRC has reported that it warned about prison abuses throughout 2003, but it was only when a young soldier came forward, on January 13, 2004, that an investigation was launched. The question must be asked, why did the military only get serious about this problem when one of its own broke silence?

General Alexander and General Burgess, you're both senior military officers with responsibilities for intelligence collection. The ICRC made a litany of complaints about interrogations at Iraqi prisons for more than a year. Why wasn't an investigation launched into those complaints? Why were our civilian and military leaders sitting on their hands waiting for a whistleblower to come forward, when ICRC reports were being stacked from floor to ceiling?

General ALEXANDER. Sir, I'll answer that first. I believe you're correct, that when that report went forward—and, as I understand, it went forward to General Karpinski, and she responded to it. What I would do in that situation is just as you said, I think an investigation should be done to look into the incidents that the ICRC had done at that time. I do not know if General Karpinski did such an investigation. I do not know the answer to that. But I do agree with you that if those allegations that were made in

there were known to them, they should have investigated it right then.

General BURGESS. Sir, and I would agree with what General Alexander said. I would also highlight that on the Joint Staff, as the J-2, I never saw the ICRC report, until here in the last week.

Senator BYRD. Why were not the ICRC reports taken seriously? Didn't anyone stop to think that there was a problem here? Was everyone just passing the buck, right up until the moment that this young soldier stepped forward? Why did it take until last week for the ICRC reports to make it to your desk? Shouldn't you have been seeking out these reports rather than waiting for them to come to you?

General Alexander?

General ALEXANDER. Sir, that is a great question. As I understand it, those reports go to the JAG at the CJTF-7 and were given to the MP brigade commander at the time who was in charge of the facility to answer. They were not widely disseminated at that time. Why they were not widely disseminated, I do not know. Going out and finding them, it's hard to understand. I would like to do that. I mean, exactly what you said. Had I known that there was a report out there, exactly, I would go after it. It's difficult to know to go after one that you don't know is there, to be honest.

Senator BYRD. General Burgess?

General BURGESS. Sir, I understand the system, as he has laid out, and I would highlight that is also the system that I am familiar with, based on Guantanamo. When the ICRC does their looks down there also, they are provided to the commander down there, which is the situation I'm more familiar with, because I was involved in that process. So it should have been dealt with, but that is the process that we currently have in place.

Senator BYRD. The ICRC reports that 70 percent to 90 percent of the Iraqis in detentions were wrongfully arrested. If the military and the administration seek to win the hearts and minds of the Iraqi people, it will not be done by rounding up the usual suspects and throwing them in dysfunctional prisons for no reason. General Alexander, how can you justify a wrongful arrest rate of up to 90 percent? Who ordered the policies that resulted in the arrest of nine innocent Iraqis for every one criminal or terrorist taken to prison? Has anyone ordered an end to arbitrary arrest of the Iraqi people, or is this just another issue that will be subject to another investigation?

General ALEXANDER. Sir, I don't know how to answer that question, but let me try this way. As I understand it, no one is going out and just arresting people. In each case, the reasons for arrest are based on shootings, an incident, or intelligence that they have. I saw the report that you saw, that 70 to 90 percent. I do not know that that's true. I do know that there are a number of people that have been arrested that, after further screening, it was determined should not be arrested, but I don't know the percentage to that, sir.

I do know that the commanders on the ground who are trying to protect their troops and the Iraqi civilians, when you have people armed with weapons who are in an area that is shooting at either our people or the Iraqi people, that's wrong, and that is one of the reasons that many of these people are apprehended. How

you go about that, that is a very difficult thing. The essence of your question, though, and how to, as you put it, win the hearts and minds of the people, is one of the things that we really have to work at. That is the key to solving not only that problem, but the rest of the problems in the Middle East.

Senator BYRD. Has anyone ordered an end to these arbitrary arrests?

General ALEXANDER. You see, sir, I don't know that anybody is doing arbitrary arrests, as you say. I don't know that. So, therefore, I don't know that they've ordered an end to it. I don't know that they're setting up—as far as I know, they are not doing that.

General BURGESS. I have not seen any indication of arbitrary arrests, sir. The only thing that I am familiar with, in terms of—as individuals that have intelligence value are picked up by the units, whether it be battalion or brigade, the general standing operating procedure is, the brigade will hold onto them for up to 14 days and conduct interrogations for actionable intelligence, and then, following that time frame, they will be evacuated to Abu Ghraib or to another holding area.

Senator BYRD. I thank you, Mr. Chairman.

Senator INHOFE. I thank the Senator.

In case our panel is wondering, there is a vote taking place right now, and so I'm going to stay here and keep it open until someone returns. So I may have 15 or 20 minutes here.

First of all, let me share a thought with you. You describe, General Alexander, the acts perpetrated by the seven as being reprehensible, and I certainly agree with you. I have spent a lot of time looking, since this first became public—and I think it's gotten way too much publicity, quite frankly, and I think a lot of it, as I said this morning, is politically charged. But those reprehensible acts, as near as I can determine, were confined to about seven people. I understand those seven people are, right now, being prosecuted within the system, and that's taking place as we're talking.

Now, first of all, is that your understanding, too?

General ALEXANDER. Yes, sir. I would add that others who witnessed it, and did not report it, are also responsible, and those people will be held accountable, too.

Senator INHOFE. Do you know about how many of those there are?

General ALEXANDER. Right now, I know of two or three more who will come forward in that category, so that those that you see in the pictures, that they were in the pictures, even if they say, "All I did was see this," they should have reported it, and they were wrong.

Senator INHOFE. Yes. My concern has been what effect this is having on our ability to get actionable intelligence. This has been a great concern of mine. First, if this hadn't become public, if this hadn't come into the public arena as it has, is it your belief, each one of you, that this would have been handled internally anyway?

General ALEXANDER. Absolutely, sir.

General BURGESS. Yes, sir.

General ROMIG. Yes, sir.

Senator INHOFE. In fact, wasn't it being handled long before that happened?

General ALEXANDER. Yes, sir.

Senator INHOFE. As I look at the timeline and I see that starting on January 3, 2004, the different things that happened, they jumped right in, and I commended them this morning—General Taguba—the fact that he did that all in just a little over 1 month, that's beyond the call of duty. So I would say that, and I think it's important that we tell the people of America that this would have happened anyway.

I had—45 years ago, I was in the Army, and I was in the court system. I was a court clerk. I think I saw one general the entire time I was in the Army. But, nonetheless, I recall some of the things that were going on at that time, and there are always court-martial going on. This is not unusual. It's taking place. They're not highly publicized. It's probably good that they aren't highly publicized, and sometimes these are being abused.

Now, would you say that because of this, things are going on, in terms of securing actionable intelligence as if this hadn't happened?

General ALEXANDER. Sir, I will tell you that General Miller is now in charge of Abu Ghraib. He is a great officer. He understands the process, and he understands the law. He has gone around and talked to all of the MPs and all the interrogators and the rest of the support troops there at Abu Ghraib and the other facilities and told them how important their work is. Don't let the actions of a few stop the important work that they're doing, because it is important. Sir, I think that is exactly right. He is a great leader. He's not an MP officer, he's not an MI officer. He's a combat leader who's taken charge of that facility based on experience and lessons that he learned at Guantanamo.

Senator INHOFE. I was down at Guantanamo, and I saw that, and I think it's very important for you folks, or us, to keep reinforcing this, that these are things that are confined to just a small handful of people. If you had, such as we know there were, about 700, I understand, guards at just this one prison, but there's some 25 other prisons, too—that it's something that we need to keep reminding people.

Chairman WARNER [presiding]. You can go vote.

Senator INHOFE. Let me finish when I get back.

Chairman WARNER. A vote is on, and we're trying to keep the hearing going.

Senator Dayton, have you voted?

Senator DAYTON. Yes, sir.

Chairman WARNER. Fine. Would you like to take your turn now?

Senator DAYTON. Thank you.

General Alexander, if I understand your remarks correctly, are you asserting that the Taguba Report, the ICRC Report, and the pictures of the prisoner abuses that we saw last week all refer to the same limited number of events that were carried out by a few MPs, with a couple of unidentified low-level MI officials perhaps interacting with them to lead them to those actions?

General ALEXANDER. Sir, I'd note that in the ICRC Report it says that one of the detainees had women's underwear on their head. I, you, the American public saw that photo on TV. That led me to make that statement that those same things that they noted in

their report we see in a photograph. So, yes, sir, that is why I made that. Now, I'm not asserting that it is only isolated to seven people at one facility, everybody else is pure. I would not make that statement. I'm saying that the incidences I looked at, the ICRC allegations, and as I look at these allegations I see a very close parallel, and that that committee report was done on two visits in October.

Senator DAYTON. I'm sorry, what committee, sir?

General ALEXANDER. The ICRC Report was done based on their visits in October to Abu Ghraib. That's why I made that statement, and I believe that is accurate. Now, the ICRC could say—you see, I don't know who was photographing, and they didn't know either; they just said it was being photographed, and they made that statement. Does that make sense?

Senator DAYTON. It does make sense. It may well be the same individuals, although the report, as I read it, refers to other abuses that occurred in that prison to other prisoners that didn't fit the descriptions in those pictures. But I guess I just wanted to clarify, for my own understanding, what you're implying here, because, as I read the ICRC Report, it refers to 14 other—or a total of 14 detention centers or prisons, and I don't know how to quantify the extent of the violations that they are alleging, but it certainly appears to be far broader and more systemic than one set of incidents photographed at one prison. Would you concur with that sir, or do you—

General ALEXANDER. Yes, sir, I think—in the ICRC Report, there was one portion on Abu Ghraib—

Senator DAYTON. Right.

General ALEXANDER.—which is what I was referencing.

Senator DAYTON. Okay.

General ALEXANDER. There are allegations, and there are investigations ongoing at other prisons. Anytime someone does something that violates the law, we ought to ensure that we begin an investigation. Normally, a criminal investigation, the Army Criminal Investigation Division (CID) does that.

Senator DAYTON. The references—and, again, it's hard to know exactly who—it's impossible to know who they're referring to, but there are a number of references in the ICRC Report to MI personnel, and how that they—to characterize these—what they say are various abuses. Some officers told the ICRC that the widespread ill-treatment of persons deprived of their liberty during arrest, initial internment, and tactical questioning was due to a lack of MPs on the ground to supervise and control behavior, the lack of experience of intelligence officers in charge of “tactical questioning.” What is tactical questioning?

General ALEXANDER. Sir, that's at the maneuver-battalion/maneuver-brigade level. When you first get a prisoner, what are the questions that you ask him? We actually did send a tactical questioning training team over to all the divisions to train them on the standards for that.

Senator DAYTON. All right, thank you.

Another part of the report says, “Several military intelligence officers confirmed to the International Red Cross that it was part of the military intelligence process to hold a person deprived of his liberty naked in a completely dark and empty cell for a prolonged

period, to use inhumane and degrading treatment, including physical and psychological coercion against persons deprived of their liberty to secure their cooperation.” This is not referring to the Abu Ghraib facility. I take it that certainly would appear to violate the edicts that you have described.

General ALEXANDER. Absolutely, sir.

Senator DAYTON. It also refers to other MI. Referring to Abu Ghraib, the MI officer in charge of the interrogation that they witnessed in early October explained that this practice of denying them of their—keeping them completely naked in empty concrete cells, in total darkness, allegedly for several days. The ICRC investigators interrupted his visit and requested an explanation from the authorities. The MI officer-in-charge of the interrogation explained that this practice was “part of the process.” The process appeared to be a give-and-take policy, whereby persons deprived of their liberty were “drip-fed” with new items—clothing, bedding, hygiene articles—in exchange for their “cooperation.” Again, this would violate the practices of the—

General ALEXANDER. Absolutely wrong.

Senator DAYTON.—instructions?

General ALEXANDER. Absolutely wrong.

Senator DAYTON. How, then, were these—if these are MI officers, how are they getting—how are they deviating, then, from—and to what extent were they—to what extent were there MI officers who were deviating from what you said were the clear instructions they had received?

General ALEXANDER. Right. Sir, here’s what we have to clarify on that point, which we do not know. Who is the person they referred to as a “military intelligence officer”? Was it one of the contractors or was it one of the interrogators? Both did not wear rank, as is normal practice, because you don’t want an interrogator who is a Spec-4 interrogating a major. In some cultures, that would never—they would never get anything. So they go in without rank, and so it may be that an interrogator, civilian or military, indeed, said that. If that happened, that is one of the individuals that we need to find and hold accountable.

Senator DAYTON. I’d just—my time is expired, but how are—what steps have been taken to assure that this is not happening now, and will not happen in the future there?

General ALEXANDER. Sir, clearly, with General Miller there, not only do we have the supervision, but he is going back and ensuring everybody understands those requirements and, I think, forcing the leadership from both the units to be at the facility 24 hours a day. That’s what needs to happen.

Senator DAYTON. Thank you.

General ALEXANDER. Yes, sir.

Senator DAYTON. Thank you, Mr. Chairman.

Chairman WARNER. Thank you very much, Senator Dayton.

I’m going to ask the indulgence of my colleagues. I just left the floor, as all of us did, in connection with voting, and the Senators on the floor are in a virtual state of shock about this report about this alleged beheading, and it brings to mind a concern. It’s all right in here, very clearly. We’re waiting for the Fay Report. We

don't know how long that's going to be. How many weeks or months might that Fay Report take?

General ALEXANDER. Sir, he's trying to get it done within a month.

Chairman WARNER. Within a month. Then I suppose, it has to be chopped on by General Abizaid in the chain—in CENTCOM. Would that be correct? In other words, how soon can—whether it's Congress or internally within the executive branch, Department of the Army, DOD—we begin to address where the problem might lie so that it can't be repeated? Because it is clear in this report that our service men and women serving in Iraq, Afghanistan, and around the world are now—could well be subjected to this type of threat.

General ALEXANDER. Yes, sir.

Chairman WARNER. As a matter of fact, the first question I asked on the last—to the hearing with Secretary Rumsfeld and the Chairman of the Joint Chiefs was to General Myers. I asked if these stories are generating a greater risk to your men and women in uniform worldwide? The answer was yes.

You have to balance the UCMJ, comparing all these reports with the need to really, and on almost a real-time basis, begin to deal with this problem so it can't happen again or proliferate further.

Can you comment on the enhanced risk to our forces in your intelligence channels? What evaluation have you made?

General ALEXANDER. Sir, first, we are taking actions right away. We are not waiting on the Fay Report to fix anything. We're waiting on the Fay Report to find more information on others who should be held accountable. We are taking actions, and that's what you're seeing. Those people who we can hold accountable now, who should be charged, are being charged. As General Taguba explained, he did not go into the depths on the MI part of this, and we need to do that and find out, just as Senator Dayton brought out, if there were MI officers or personnel involved, and hold them accountable. So we're doing that in parallel. We're not waiting.

Chairman WARNER. All right.

General ALEXANDER. Currently, sir, we're fixing—

Chairman WARNER. I don't want to take up too much time.

Did you have any further comments, General Burgess, on this situation, the enhanced risk to our forces worldwide, particularly in Iraq and Afghanistan?

General BURGESS. Sir, as you highlighted, from what Chairman Myers and Secretary Rumsfeld said, Chairman Myers has given me direction to pay attention since this incident, and we have been following the intelligence. There has been an up-tick, a little bit—

Chairman WARNER. Don't use the word up-tick.

General BURGESS. I'm sorry, sir. There has been an increase, if you will, in some of the threat reportings. We have followed that. We have also been following the foreign press as we have followed that. This incident this last weekend that you're reading about, which occurred on Saturday, is one that we are taking a look at to see if we can make a direct correlation to, but at this time have not been able to.

Chairman WARNER. The committee would like to have copies. You have a report that goes out, which is—it's in the open—about

intelligence repercussions. I used it once upon a time. We'll see that we get it from you.

Senator Allard.

Senator ALLARD. Thank you, Mr. Chairman.

Senator Roberts brought up the beheading article in his questions and I just want to compliment you on the great response that I think you gave. We still need to comply with the Geneva Conventions and that we still need to welcome oversight, like from the ICRC, and that you do welcome oversight, like from the committee. But there is an inherent risk when we make this public, and I think we all need to recognize that. But I also think it highlights the difference between our system and our way of doing things, as opposed to our opposition so many times, who refuse to comply with that. I understand the need to do that. Because if we can make these work, and we get our adversaries to comply with it, it means our people, our men and women who are serving in the Armed Forces, if they happen to be prisoners, have a better chance of survival.

So I compliment you on your foresight. This is unfortunate that this happened, and it's just—when you make things public like this, this is what happens. You're going to increase antagonism on the other side, and we need to think about those things.

I was struck by the fact that there were people within the prison, an individual, at least one, who knew the rules well enough to report an infraction, and knew that he could do that. In fact, he was encouraged to do that. So the message got down to some of those people who were working in the prison. Apparently, it didn't get to some of the others. Can you explain the discrepancy in why some of them got the message and some of them didn't? Or is it your view that some of them decided just to ignore the law?

General ALEXANDER. Sir, I believe that it was a group that lacked discipline and leadership. I think that—your latter statement is the more accurate. I think that's really what happened. I know that, as I stated earlier, cases that were brought up, people were disciplined, and corrective action taken. So there were people who knew the rules and brought them forward consistently. It was not just that one. There were a couple of instances that I—for the record, those incidences. But you will see, in those incidents, that, in fact, they were—when they were brought up, the leadership immediately took action, brought the JAG in, said, "Okay, what happened?" So I think that—I think that needs to come out. Because I think the perception is that we're not all—but when those things were going on—I don't know, as I said earlier, what was done about the ICRC Report, whether an investigation was started on that.

Senator ALLARD. My perception is that actually there was a problem being recognized before this incident actually happened, in October and December, and there were already—

General ALEXANDER. Right.

Senator ALLARD.—people beginning to become made aware of this, and there was beginning to be some review. But, obviously, you can't jump ahead of the review. You have to establish the facts before you can take action. Am I correct in assuming that there al-

ready was some review beginning to take place, before the 1st of October, of the prison system and how we were handling prisoners?

General ALEXANDER. There clearly are reviews that went on, in terms of when General Ryder went over to look at the prisons for General Sanchez.

Senator ALLARD. That was part of routine review, I guess.

General ALEXANDER. That was part of a routine—yes, sir.

Senator ALLARD. Okay, very good.

General ALEXANDER. When General Miller went over to look at how they set up and how they get that—how they set the flow of information, that also was important.

Senator ALLARD. General Alexander, at any time after September 11, 2001, did the Army staff develop or issue to field commanders a revised doctrine for collecting intelligence specifically through the strategic exploitation of battlefield detainees or enemy prisoners of war?

General ALEXANDER. Sir, we didn't put out a revised doctrine, per se. But I will tell you that we did look at how we do data-mining, as the Department of the Army and as the Intelligence Community, and how we used that data-mining to support analysis. Our intelligence system has an awful lot of information, and that some of that information may apply to the guy who is being interrogated. In the past, we were never able to use that. Some of the tools and things that we do use and that we have pushed forward, allow us to take advantage of all parts of our Government for the interrogators, so when they set that interrogation package up—that's one of the things that is evolving, and I think it's exceptional.

Senator ALLARD. General Burgess, did the Joint Staff develop—same question—or issue to field commanders revised doctrine for collecting intelligence specifically through the strategic exploitation of battlefield detainees or enemy prisoners of war?

General BURGESS. Sir, there wasn't any doctrine, if you will, that was promulgated. But what I will tell you, since you picked on September 2001, is that as we stood up Guantanamo Bay, in December 2002, we pulled together across the community, across the Intelligence Community and the military, those folks who had some insights into how we would do that. I had to go back to the Vietnam War and the Korean War to find the last time we had held detainees and conducted strategic debriefing, if you will, in the numbers we were talking about, because even when we conducted Operations Desert Shield/Desert Storm, in the early 1990s, we gathered a lot of people, but we didn't do much, in terms of interrogation, before the war was over and we released. So we hadn't set up a process. So it was a re-learning experience in some cases.

Senator ALLARD. General Romig, would you characterize for us the number, just a rough estimate, of the UCMJ hearings the Army conducted during Operations Enduring Freedom or Iraqi Freedom regarding the mistreatment of enemy prisoners of war or battlefield detainees or other such prisoners? Then, the final question, where is the threshold? At what point does this trend reach such a level that the Chairman or the Secretary of Defense (SECDEF) needs to intervene?

General ROMIG. Sir, we've been tracking these since probably end of November, first part of December, all detainee abuse cases, both in Iraq and Afghanistan. We currently have about 83 cases. Twenty-two of those cases were cases that were initiated at the unit level. Somebody came forward and reported misconduct. A lot of it was low-level misconduct. Often, at the unit level, it was at roadblocks and things like that, where somebody mistreated a civilian. But we're tracking all of those. The units are handling those with a wide variety of disciplinary actions, from court-martial down through article 15 non-judicial punishment and administrative actions, reliefs, administrative eliminations from the service, and all those kinds of things. So 83 is the number we have right now, sir.

Senator ALLARD. Thank you.

Chairman WARNER. Thank you very much, Senator.

Senator Lieberman.

Senator LIEBERMAN. Thank you, Mr. Chairman.

I've been thinking—and I gave voice to this the other day in this hearing—that in our pursuit of justice for those who have committed what you, General Alexander, quite appropriately described as reprehensible acts in the prison in Iraq, which have angered, embarrassed you in the military, we in Congress, the American people, that there was a danger that people might misunderstand who has the moral high ground generally, and Iraq specifically. In my opinion, the zeal with which we pursue this wrongdoing, punish those responsible, make sure nothing like it exists anywhere else in our American military prison system, assures us and the world that we do have the moral high ground. I've worried, as I've watched the public opinion polls, with support seeming to drop in the last week for our mission in Iraq and the focus on these investigations, that there was beginning to be a blurring of that distinction.

Then we hear this story, which I assume, for the moment, is true, of al Qaeda beheading an American. There we see what is exactly the truth. We have the moral high ground in Iraq. Our enemies are the exact opposite. They are inhumane and immoral. There's not going to be any investigation by any al Qaeda legislative body of how that happened. Osama bin Laden and Zarqawi are not going to apologize to that man's family or to the American people.

I hope that this awful inhumane act brings us to clarity that what happened in that prison was wrong, that we will search it out and eliminate it, and that it does not diminish the support for our cause in Iraq, which I consider to be not only moral, but fundamental to the future security of the American people.

What's going to happen if these people, who beheaded this man, our enemies who are fighting us, force us to retreat from Iraq? Think about how they will be emboldened and how our future and the future of our children will be compromised.

In that regard, I greatly appreciated your answer to Senator McCain's question about the Geneva Conventions, we embrace it because it's the law of the land, and we believe in the rule of law, and we want our prisoners to be treated humanely.

In that regard, I want to ask you a few questions. I remain uncertain about the application of the Geneva Conventions to detain-

ees in the prisons in Iraq. Secretary Rumsfeld testified the other day that he felt they weren't entitled to the rights under the Geneva Conventions, but they were generally going to be given them. Maybe General Romig, on behalf of JAG, if you participate in any meetings and you understand this—we understand that the people at Abu Ghraib didn't follow the Geneva Conventions, that's obviously and painfully clear. But what was the state of the understanding of the rights of those who were taken as detainees if they were not formally under the Geneva Conventions? If they were not, why weren't they?

General ROMIG. Sir, there's really two bases to say that we apply the Geneva Conventions to these folks. First is, DOD policy and Joint Chiefs of Staff instructions say, for all conflicts that we're going to be involved in, we're going to apply the Geneva Conventions, but, additionally, Geneva Conventions number four applies to the situation of an occupation or where we're running the government, and these individuals—number four is for civilians.

Senator LIEBERMAN. Right.

General ROMIG. Number four is the one that we are applying in Iraq. One of the things that we're doing, and I don't know if this is the time to do it, but I wanted to dispel the——

Senator LIEBERMAN. Forgive me——

General ROMIG. Yes, sir.

Senator LIEBERMAN.—I just wanted to make clear that you would say that all of these security detainees are entitled to rights under the Geneva Conventions—not as great as POWs, but rights, nonetheless.

General ROMIG. A sliding scale of rights, depending on what they're being detained for and—but, certainly, yes. What I was going to illustrate is, we have a procedure for detainees being brought in, in Abu Ghraib and all of the other detention facilities, where there is—first off, they have to have an apprehension form, Coalition Provisional Authority apprehension form, two sworn statements. They go through a screening process, and, within 72 hours, our magistrate cell of three to five JAGs at Abu Ghraib, do a review of the evidence to see if they're being properly detained, if there's evidence to support probable cause to believe that they've committed the offense. On top of that, we also afford them Article 78 of the Geneva Conventions number four, which requires that you apprise them of why they're being held, and an opportunity to either appeal or provide a statement. We do that for every detainee.

Senator LIEBERMAN. As far as you know, that was done, the detainees who we see humiliated and otherwise abused in those pictures?

General ROMIG. Yes, sir.

Senator LIEBERMAN. Let me ask you another kind of question, which goes to the credibility of the investigation. I know there are a lot of investigations going on. General Fay, the Inspector General, seems to be doing something, and we've asked questions here at our hearings about up the chain of command. Is there any group now investigating that question of whether there was culpability up the chain of command of the behavior that we have all been so offended by in the Abu Ghraib prison?

General ROMIG. Sir, there are two ongoing investigations. General Alexander mentioned the Procedure 15, which is looking at the MI side, but that's up the MI side of the chain, and there is an ongoing CID investigation that is looking at taking all the leads from all the interviews they do and running it wherever it might go.

Senator LIEBERMAN. Again, none of those is limited to the people seen in the pictures or in cell block 1A or even at Abu Ghraib. They're going to go as high as the investigation takes them.

General ROMIG. It depends on the evidence they develop, yes, sir.

Senator LIEBERMAN. A final question—I apologize, my time's up—what about this group Secretary Rumsfeld announced Friday, which seemed to get lost in all the news about his testimony, the commission that is headed by Secretary Schlesinger and Secretary Brown and a couple of others. Do you know what their authority is here?

General ROMIG. Sir, I do not know the authority. I've not seen their charter, but I think it is a good idea.

Senator LIEBERMAN. What do you think they're going to do?

General ROMIG. Sir, I think they're probably going to make recommendations on both detention procedures and interrogation procedures, and look at just an outside look at what we're doing.

Senator LIEBERMAN. Okay, thank you.

Thanks, Mr. Chairman.

Chairman WARNER. I thank you, Senator Lieberman, for bringing out those points.

We're almost in a lock-down for getting information, subject to the completion of all these investigations, which are necessary. But I'm just concerned.

Senator Inhofe, you had some time.

Senator INHOFE. Yes, my questions were interrupted by a vote, so let me just go back and pick up where we left off.

First off, I think we concluded that in the absence of all the publicity and all of this, that the seven people who are responsible for the acts we've been talking about would have been and were being prosecuted anyway to the same degree, and then also that I believe you said my concerns should not be all that great, that because of all of this that you are inhibited in what you're able to do, in terms of your gathering intelligence information now. In other words, you're still ongoing in getting this information. Do you all agree to that?

General ALEXANDER. Yes, sir.

Senator INHOFE. Okay. Now, you were here, I think, when General Taguba was testifying this morning, and I asked him a series of questions, in terms of did he really feel that the offenses, that the reprehensible acts, were confined to cell block 1A and 1B of one prison, and then, in addition to that, that we don't have any evidence that this is going on at any of the other 25 prisons. He agreed to that. Do the three of you agree with that?

General ALEXANDER. Yes, sir.

Senator INHOFE. As far as you know.

General ALEXANDER. Of this sort.

General BURGESS. As far as I know.

Senator INHOFE. I think that's very important, because there's an article this morning in the Washington Post that alleged abuses

like those in the prison are widespread, and not isolated, and I just think it's a bad message to send out since the message is wrong, and I wanted to hear all of you express yourselves.

Now, as far as the cell blocks 1A and B are concerned—more hard-core guys, aren't they?

General ALEXANDER. Yes, sir.

Senator INHOFE. I understand that you have three categories. One was enemy POWs, one was Iraqi crimes against Iraqis, and one was Iraqi crimes against the coalition. So it is that last category where the most serious ones are, is that correct?

General ALEXANDER. Those who have great intel value, yes, sir.

Senator INHOFE. Intel value, that's good. Now, something was brought up by Senator Byrd, and he was quoting from this report, and I want to clarify this, because I think it's very, very important. In fact, I was criticized. These people didn't understand what was said in the report that came from the ICRC. They talked about 70 to 90 percent of the persons were deprived of their liberty in Iraq and had been arrested by mistake. I have been told that as you arrest people, and we find out that, number one, they didn't do anything that was all that bad, and, number two, they had no value, in terms of intelligence, that there's a revolving door, they go right back out. I would suggest that this 70 to 90 percent would include all those people who were brought in, and then they found out they didn't have anything of any value to us, in terms of intelligence. Do you want to comment on that?

General ALEXANDER. Sir, the 70 to 90 percent, I don't know where we get that number, and I don't know that that is an accurate number. I do know that, just as you said, when they find they have a person who was wrongfully arrested, the intent is to get that person back out as quickly as possible.

Senator INHOFE. I think that's exactly the answer I was looking for. A lot of people out there are thinking that 90 percent of the people arrested didn't do anything, and that just flat isn't true.

Mr. Chairman, thank you very much.

Chairman WARNER. Thank you very much, Senator Inhofe. Senator Reed?

Senator REED. Thank you very much, Mr. Chairman.

General Alexander, when was General Fay appointed to conduct his investigation?

General ALEXANDER. Sir, the 7th of April is my understanding of the date that he was appointed, and I think that was the day after the 15-6 investigation was signed off.

Senator REED. Now, General Sanchez received a report from the ICRC in February, is that correct?

General ALEXANDER. Sir, General Sanchez's headquarters received it. I don't know when General Sanchez got it.

Senator REED. But his headquarters received it in February. Within this report, there are allegations or actually statements by the inspectors. In particular, they witnessed the practice of keeping persons deprived of their liberty, completely naked in totally empty concrete cells, in total darkness, allegedly for several consecutive days. First, that's a violation of the commander's guidance.

General ALEXANDER. Yes, sir.

Senator REED. That's a violation of the Geneva Conventions.

General ALEXANDER. Exactly, sir.

Senator REED. So this report is received in February.

General ALEXANDER. Yes, sir.

Senator REED. In this particular incident, the explanation for this behavior was because the MI officer said it was part of the process.

General ALEXANDER. Yes, sir.

Senator REED. From February to April—

General ALEXANDER. No, sir. Let me, if I might—

Senator REED. Go ahead, General.

General ALEXANDER. We touched on this briefly before. In the identification of who's a MI officer—

Senator REED. General, if you'll excuse me, the sequence is that the report's received by headquarters in February—

General ALEXANDER. That's correct.

Senator REED.—containing this information, which would raise, I think, serious concerns about policy, about practice, about compliance with the Geneva Conventions in the intelligence operation, regardless of who the individual is. It takes until April 4 to appoint an investigating officer.

General ALEXANDER. Sir, there's an ongoing investigation at that time, which is the Taguba investigation on that facility.

Senator REED. General Taguba testified earlier today because of his mission he was not required to, nor was he encouraged to, investigate the MI aspects. Is that correct?

General ALEXANDER. That's correct. When that was brought out—as soon as that was brought out and made public, to the best of my knowledge—you see, I did not receive a copy of the ICRC Report until this week.

Senator REED. Now, I understand from your testimony that General Karpinski received a report even before General Sanchez.

General ALEXANDER. That is correct, sir. My understanding is, she did an out-brief in November of that report, and she responded on the 24th of December with actions.

Senator REED. She did not inform General Sanchez or his headquarters of these allegations which violated his policy and which violated the Geneva Conventions?

General ALEXANDER. I do not know who—I understand, but I do not know who, other than the JAG—is my understanding is the only person who had information at the CJTF-7. But, sir, I will have to take that for the record to give you the exact answer. I do not know.

[The information referred to follows:]

Lieutenant General Sanchez can provide the most authoritative answer on when he became knowledgeable on the findings of the International Committee of the Red Cross on Abu Ghraib.

General ALEXANDER. The other part that we answered on that was, we do not know if General Karpinski started an investigation based on the incidents that were in those reports, because, as you point out, they're illegal.

Senator REED. General Burgess, the JIDC, that's a joint asset, not an Army asset, is that correct?

General BURGESS. Sir, it is joint.

Senator REED. Colonel Norton is an Army officer, former JDIC commander, Colonel Steve Norton?

General BURGESS. I'm not sure if he is an Army officer or not.

Senator REED. Do you know anything about his background, where he's served before?

General BURGESS. No, sir, I do not.

Senator REED. Were you involved with General Miller's trip, in terms of being briefed about it or being involved in his trip in August in which he talked about a different regime, if you will, in that prison?

General BURGESS. Yes, sir, I was.

Senator REED. Are you aware of the recommendations he made, including that the MP should be preparing prisoners for interrogation?

General BURGESS. Sir, when he did his report, that was provided to the theater, and it was not provided to the Joint Staff; however, I did talk to General Miller, and subsequently received a copy of that report.

Senator REED. So you were aware of the fact that he was recommending something which General Taguba had recognized as being—at least if carried out, would be violating Army regulations and maybe even implicated in the Geneva Conventions?

General BURGESS. Sir, I was aware, as I looked at what General Miller said, and I have read his report, and I have looked at slides that accompany that. I interpreted what General Miller had said in a different manner, I think, than maybe General Taguba may have, and that probably came from my working with him down at Guantanamo.

Senator REED. Did Secretary Cambone's office receive the same briefing, to your knowledge?

General BURGESS. Sir, I do not know if Secretary Cambone received it or not.

Senator REED. Who else, to your knowledge, received the briefing from General Miller about his recommendations or saw the report or slides?

General BURGESS. Sir, as far as I know, I can only confirm that General Miller's report was provided to Lieutenant General Sanchez. If it was provided higher, I'm not certain. I have slides that were prepared for the DOD, but I have not been able to confirm that they were ever presented.

Senator REED. The ROE that you have handed out, General Alexander, were they changed in any respect with respect to the Miller—

General ALEXANDER. No, sir. Those rules, as I stated, stem from our FM on interrogation operations, and so when you look at that, that manual was written in 1984, and it's consistent. So it's one that we have—

Senator REED. General Miller recommended the establishment of the theater JIDC in his report. Is that correct?

General BURGESS. Yes, sir, he did comment on that.

Senator REED. General Sanchez approved that?

General BURGESS. Sir, I would assume General Sanchez approved that, because they, in fact, formed a JIDC.

Senator REED. Can you also assume that General Sanchez approved his recommendation with respect to using MP to prepare the prisoners for interrogation?

General BURGESS. No, sir, I cannot assume that, because I have not seen any authorities or promulgation put from General Sanchez following the release of the Miller Report to him.

General ALEXANDER. Sir, may I comment on that? Because I think it's taken out of context. I know what it says, but I honestly believe that that is taken out of context. I have talked to General Miller on what he meant. I have read our doctrine from both the MP and the MI side. The part about where MP and MI have to work together for screening and for understanding the mindset of the prisoner before he's interrogated is something that we do have to closely work on, and it is something that was broken.

Senator REED. Mr. Chairman, might I ask one follow-up question?

Chairman WARNER. Yes. If I may say, you have a very important line of questioning, and you may take another minute.

Senator REED. General Alexander or General Romig, is, anywhere within the Miller report or the slides, clearly stated that the situation in Iraq is different than Guantanamo, that the Geneva Conventions applies in Guantanamo? I ask this because the interpretation of what is meant by preparing prisoners in the Guantanamo environment has a much different legal and practical connotation. In the Iraq environment, it has a much, much different connotation. It appears that the Guantanamo connotation found itself in Iraq, as prisoners were being, in this report, subject to the violations of the commander's guidance. Also the Geneva Conventions, did you see anything where it was emphasized the fact that this would be two separate situations? General Romig, I think you concur with my analysis.

General ROMIG. Yes, sir, they are two separate situations, but I did not see the slides on that, so I don't know.

Senator REED. General Alexander? General Burgess?

General ALEXANDER. Sir, I've seen the slides, and, again, I've been to Guantanamo, and I talked to General Miller after his visit to Iraq. Clearly, before going to Iraq, his concern was they had enough people. Iraq was getting all the interrogators. They don't need the help. He went over there, and he saw some of the conditions in the camp—that was prior to Abu Ghraib—and he helped fix that. That was the old Camp Cropper. So one of the things that he did in his time there was, for General Sanchez, looked at what needed to be fixed in other camps, the humane treatment, and the facilities that we have at Guantanamo are an order or magnitude better than the facilities we have in Iraq. He understood that right away. Sir, he also understood that the ability to integrate intelligence into interrogations and what he called the flow of information that he had at Guantanamo does not exist in Iraq, because the system was not there to support it. All of those needed to be fixed, and those were the key things he was talking about. Nowhere—and he added a line in his report to have the legal review or recommendations to make sure what we're saying is correct. But, sir, I believe that what he said was honestly correct, and I believe that there was no intent to, as it is taken, to, quote, "soften up" pris-

oners for interrogation. I know it says it, and people are quoting those, but I've talked to General Miller, and I will tell you, I honestly believe that he did not say it in those manners.

Senator REED. Just a final question.

Chairman WARNER. We need to move on, Senator. I thank the Senator.

General ROMIG. Sir, if I could, there's one final point, if I could, on General Miller's—if you read his report, his primary focus was in three areas—integration, synchronization, and fusion. That's where his report went and how that comes together and works. The line on “softening up,” as I read the report, that does not come out, to me, in terms of doing that.

Chairman WARNER. Thank you. We will hopefully have General Miller before the committee at some point.

Senator COLLINS.

Senator COLLINS. Thank you, Mr. Chairman.

General Alexander and General Burgess, the February 2004 report of the ICRC states that there was a particular category of prisoners that was particularly at risk for abuse, and I want to quote to you from the report. It says that “persons deprived of their liberty under the supervision of the MI were at high risk of being subjected to a variety of harsh treatments, ranging from insults, threats, and humiliations to both physical and psychological coercion, which, in some cases, was tantamount to torture, in order to force cooperation.” That's pretty strong language, talking about prisoners who were under the control of MI being of particularly high risk.

General Alexander, you've said that this report only came to your attention, I believe you said, last week, or relatively recently. General Burgess, when did you learn of the ICRC Report? I'm talking about the February report?

General BURGESS. Yes, ma'am. Just last week.

Senator COLLINS. Shouldn't this report, with its indictment of certain MI, have been brought to your attention sooner than that? Who should have brought this to your attention, General Alexander?

General ALEXANDER. Ma'am, clearly it should be brought to the attention of the commander responsible for that theater so he can take action on it. My understanding is that the initial report did go to General Karpinski, and that she was asked to respond to that report, and did so on the 24th of December. I do not know if she, in fact, started an investigation into those, because they are serious, and I agree with you that as soon as we hear about one of those allegations an investigation should begin right away, and we shouldn't wait for it.

Senator COLLINS. I want to bring up a second issue and have all three of you comment. If a small group of guards, on their own initiative, decided to abuse their prisoners, I am very skeptical that they would have chosen bizarre sexual humiliations that were specifically designed to be particularly offensive to Muslim men. It seems to me that it is far more likely that a group of out-of-control, undisciplined guards would beat up prisoners, not strip them naked and put them in a human pyramid. That really troubles me, because it just doesn't—it implies too much knowledge of what

would be particularly humiliating to these Muslim prisoners. That is why, even though I do not yet have the evidence, I cannot help but suspect that others were involved, that MI were involved, or people further up the chain of command, in suggesting to these guards specific types of abuse that were designed to break these prisoners.

I would like to ask each of you to comment on that, starting with General Alexander.

General ALEXANDER. Ma'am, your logic is correct. I think that the difficulty is to find out who told whom what to do. As you state, the soldiers that are charged are saying that, "Military intelligence told me to do this." Now, the question is, "Who?" A defense can't be, "I was told to do it by that group or that group." "Who told you?" That's really where we need to get to. Who told them to do this? Who was that individual? That is the key to all of this.

Now, in the General Taguba Report, there were three soldiers, not interrogators, who are MI analysts that were listed, and there were two contractors listed. It appears that at least one of the contractors did tell some of them some of this, but it's not clear what they said. What complicates that, as I understand it, is, some of these soldiers now that are charged have pleaded the Fifth and are not talking to the investigators to give out the rest of what they know. So we want to get exactly the facts that you're stating, because that is important to us. To fix the system, we have to know who, we have to know what they did and why they did it, and then we have to take action, hold them accountable and fix it so that it doesn't happen again. So I agree with the way that you put that out.

Senator COLLINS. General Burgess?

General BURGESS. Ma'am, what you've laid out is logical. What I would say is, I've learned, doing intelligence work, that you close no doors, you see where the threads, as I call them, will take you. But the last point I would leave you with, in my short 30 years in the military, I'm not surprised much anymore what one person will do to another person. Just dealing with things that I've had to deal with through my career, just dealing with the situations that come up. So anything is possible. I'm not condoning, not saying it's right. It's just human nature in some cases.

Senator COLLINS. General?

General ROMIG. Senator, since we have an ongoing CID investigation and pending cases, it would be inappropriate for me to comment.

Senator COLLINS. I thought you would answer that way.

Thank you, Mr. Chairman.

Chairman WARNER. Senator, it's an excellent line of questioning. We keep coming up against the following: "CENTCOM knew it, but we didn't know it," or, "investigation is going to learn the facts." We're creeping along here trying to get at these questions. At the same time, I guess we have to observe the integrity of these investigations. But I agree with you, these youngsters didn't understand the nuances of Muslim culture, who some people say staged those photographs, which I understand were going to be shown to the prisoners' families, by way of threat, unless he came forward with some valuable information. The plot is thickening.

But I'm just curious, General Alexander, you wear three stars, you're the Chief of Army Intelligence, you train all your people, you send them to the combatant commanders. It would seem to me if they are represented to have done wrong—I don't care whether it's CENTCOM, Southern Command (SOUTHCOM), European Command (EUCOM)—they should inform you promptly of what your people are doing wrong. That's my view.

Now, we turn over here to our good friend, Senator Akaka.

Senator AKAKA. Thank you very much, Mr. Chairman.

I've been asking questions about contracted personnel. General Burgess, how many U.S. contracted personnel do we have working with our MI units? The big question is, do all of these individuals have the proper security clearance?

General BURGESS. Sir, I would like to take the response to your question for the record so I can give you an exact response.

[The information referred to follows:]

[Deleted.]

UNCLASSIFIED

CONTRACT LINGUIST UPDATE – As of 1 Dec 04

PRI	UNIT	CAT I	CAT II	CAT III	TOTAL
1 a	CENTCOM (PERSIAN GULF)	4202 / 3713 (+46)	843 / 384	49 / 28 (+6)	5084 / 4136 (+52)
1b	CENTCOM (CONUS) (DO 3)	0 / 0	0 / 0	26 / 26	26 / 26
1c	CENTCOM (EUROPE) (DO 2)	0 / 0	0 / 0	17 / 12	17 / 12
1 d	DIA / ISG (DO 7)	190 / 190	60 / 57	0 / 0	250 / 247
1 e	OSD / MNF-I (DO 8)	400 / 296 (-1)	0 / 0	0 / 0	400 / 296 (-1)
1 f	513 rd MI BDE TROJAN (DO 13)	0 / 0	0 / 0	10 / 6	10 / 6
1 g	TRR-38 / COBRA FOCUS (DO 16)	0 / 0	0 / 0	16 / 15 (+2)	16 / 15 (+2)
1 h	4 th POG (DO 17)	0 / 0	12 / 11	0 / 0	12 / 11
1i	DOJ-Prisons (DO 14)	70 / 45	0 / 0	0 / 0	70 / 45
1j	MNC-I (DO 21)	120 / 79 (+11)	0 / 0	0 / 0	120 / 79 (+11)
2	C-JTF-76 (DO 6)	199 / 192 (+9)	182 / 71 (-1)	22 / 15	403 / 278 (+8)
3a	OARDEC (DO 10)	0 / 0	17 / 10	0 / 0	17 / 10
3b	GTMO (DO 5)	0 / 0	53 / 48	0 / 0	53 / 48
4	CITF (DO 9)	0 / 0	14 / 12	5 / 5	19 / 17
5	NSGA (D/O 12)	0 / 0	0 / 0	2 / 2	2 / 2
6a	902D MI (DO 18)	0 / 0	0 / 0	2 / 2	2 / 2
6b	NCIS (DO 11)	0 / 0	7 / 6	0 / 0	7 / 6
6c	CJTF-HOA (DO 19)	0 / 0	3 / 1	4 / 0	7 / 1
7	COMUSNAVCENT (DO 15)	20 / 8 (-1)	0 / 0	0 / 0	20 / 8 (-1)
	TOTAL	5201 / 4523 (+64)	1191 / 610 (-1)	153 / 112 (+8)	6545 / 5245 (+71)

UNCLASSIFIED

CONTRACT LINGUIST UPDATE – As of 9 June 04 UNCLASSIFIED

PRI	UNIT	CAT I	CAT II	CAT III	TOTAL
1 a	CFLCCMNF-I (D/O 75)	3915 / 3391 (+203)	862 / 472 (-3)	67 / 37 (-5)	4844 / 3900 (+195)
1 b	DI/ISG (D/O 82)	190 / 184 (-5)	85 / 52 (+1)	0 / 0	275 / 236 (-4)
1 c	OSD/MNF-I (D/O 77)	400 / 193	0 / 0	0 / 0	400 / 193
1 d	116 TH / COBRA FOCUS (D/O 67)	0 / 0	0 / 0	8 / 8	8 / 8
1 e	513 TH / TRR-38 (D/O 67)	0 / 0	0 / 0	14 / 8	14 / 8
1 f	COALITION FORCES (D/O 68)	120 / 69	0 / 0	0 / 0	120 / 69
1 g	4 TH POG (D/O 64/70/72)	0 / 0	6 / 6	5 / 5	11 / 11
1 h	CPA-Prisons (D/O 78)	30 / 21 (+10)	0 / 0	0 / 0	30 / 21 (+10)
2	CJTF-76 (D/O 74)	152 / 129	187 / 53	23 / 16	362 / 198
3	GTMO (D/O 73)	0 / 0	67 / 46 (-1)	0 / 0	67 / 46 (-1)
4	CITF (D/O 76)	0 / 0	14 / 9	5 / 5	19 / 14
5	NSGA (D/O 68)	0 / 0	0 / 0	3 / 3	3 / 3
6	116 TH (D/O 56/62)	0 / 0	0 / 0	14 / 13	14 / 13
6	902D MI (D/O 59/60/61/63)	0 / 0	0 / 0	5 / 4	5 / 4
6	NOIS (D/O 57)	0 / 0	7 / 7 (+1)	0 / 0	7 / 7 (+1)
6	TOTAL	4807 / 3987 (+208)	1228 / 645 (-2)	144 / 99 (+6)	6179 / 4731 (+212)

UNCLASSIFIED

General BURGESS. We've broken the number out in terms of interrogators, linguists, and others that are providing some analytical assistance, so it actually breaks out in different ways and in three different locations. That's not—I'm talking Afghanistan, Iraq, and Guantanamo. So to give you a specific answer, I'd like to provide that to the committee.

Sir, in those cases where security clearance is required, that is written into the contract, and that is worked. There are some of the skills that we're talking about, though, depending on the category of the linguists, where different security clearances are required or may not be.

Senator AKAKA. General Burgess, it is reported that one of the two civilian contractors named in Major General Taguba's report did not have a security clearance. What are the rules regarding security clearances for contracted personnel who will be interrogating detainees?

General BURGESS. Sir, as a general rule—and I highlight “general rule”—we require at least a collateral clearance, depending on the access that the individual's going to have. However, I have asked for the specific statements of work for those contract, and have not read them yet.

Senator AKAKA. I've also read some articles on this, and would ask the question, whose responsibility is it to ensure that all of the U.S. contracted personnel have the appropriate clearances?

General BURGESS. Sir, as a general rule, that resides with the organization that “lets the contract,” and you have a contracting officer who is responsible for seeing that the contract is executed in accordance with the standards. That is normally done at the Unified Command and lower, depending upon where you're executing the contract.

Senator AKAKA. I've read some reports where the hired contractor firms claim that it is not their responsibility to do any background research or checks or investigations on any of the people they hire. Do you know that to be true?

General BURGESS. Sir, I do not know that to be true.

Senator AKAKA. Also, General Taguba's report stated that contracted personnel from third-world nations were involved in this. Do you have any comment about that?

General BURGESS. Sir, depending on your definition of third-world country, it is a true statement to say that we use foreign nationals with security clearances to do interrogations or translations.

Senator AKAKA. Can you name some of the countries that these foreign nationals are from?

General BURGESS. Sir, for example, we are using some Iraqis to do some linguist work for us, if you will, not only translation work, but also just providing those skills for the soldiers on the ground.

Senator AKAKA. What kind of training did the U.S. civilian contractors have prior to going to Iraq? I've been informed that the training for interrogators included training tactics and techniques used by other countries. Did such training occur? If so, are these tactics and techniques approved by DOD intelligence officials?

General ALEXANDER. Sir, as far as I know, they did not. The contract that I'm familiar with, the personnel who were brought on from the CACI contract were former soldiers or former U.S. who had an interrogation MOS and had been trained on the rules. Sir, as we stated earlier, they were also supposed to sign and understand the interrogation ROE.

General BURGESS. I would highlight the approaches or the interrogation techniques would still be those that are laid out in the Appendix H of the Army FM that we discussed earlier.

Senator AKAKA. Another concern I have is about records. General Burgess, who is responsible for keeping a record of all of these civilian contractors that the U.S. has in Iraq? Is this responsibility of the individual contracted firms or the DOD?

General BURGESS. Sir, I do not know the answer to that question.

Senator AKAKA. General Romig, was there any consultation between commanders—that's commanders from company, battalion, or brigade—between commanders and the command JAG regarding the treatment of detainees at Abu Ghraib?

General ROMIG. Sir, we had a JAG officer assigned to the brigade, the MI brigade. I can't tell you the day-to-day discussions, but there was a JAG officer assigned to the brigade. In addition, the MP brigade had a couple of JAG officers. As I said, there was a magistrate cell in Abu Ghraib of three to five JAG officers. So there was ample—we believe—now, having said that, we're taking a look at the resourcing and the training for our JAG and MI units to make sure we're doing it right, so we're looking at that also.

Senator AKAKA. Thank you for your responses.

Chairman WARNER. Thank you very much.

Senator Lindsey Graham.

Senator GRAHAM. Thank you, Mr. Chairman.

Hat's off to the panel. You all have done an excellent job answering a lot of questions. I think the truth is, we won't know yet. When somebody offers as a defense in a court-martial, "Someone else made me do it," it's going to take awhile to find out who that someone else is. I share Senator Collins' concern that this is probably not just six or seven people having an out-of-bounds perverted experience, it probably goes deeper. But in terms of what Senator Kennedy was asking, General Romig—is that right? Am I pronouncing your name right?

General ROMIG. Yes, sir.

Senator GRAHAM. I'm informed the Extraterritorial Jurisdiction Act exists that would allow the Department of Justice to prosecute contractors serving overseas. Are you familiar with that?

General ROMIG. Yes, sir, that is correct.

Senator GRAHAM. I would make this invitation to you. Could you and your JAGs look at that, and maybe get the other JAGs to look at it and see if we need to improve that? Because I'm not so sure it gives us all the tools that we need, but I would appreciate it if you would do that.

General ROMIG. Yes, sir, we would look at it.

[The information referred to follows:]

Section 3266 of title 18, United States Code, enacted by the Military Extraterritorial Jurisdiction Act of 2000 (MEJA), directs the Secretary of Defense, after consultation with the Secretary of State and Attorney General, to prescribe regulations governing the apprehension, detention, delivery, and removal of persons under MEJA. The Department of Defense is currently engaged in that process. The Department is also reviewing legislation to amend MEJA. H.R. 4390 was introduced on May 19, 2004, to amend MEJA to apply to employees of contractors of other Federal agencies when their "employment relates to supporting the mission of the Department of Defense." Currently with respect to contractor employees, MEJA applies only to an employee of a Department of Defense contractor.

General ROMIG. One additional point about that. There are implementing instructions that are on the Federal Register right now that DOD has put out. Prior to that, though, the Air Force has prosecuted two cases under that act.

Senator GRAHAM. Thank you, and if we need to improve it and make it tighter, I would appreciate that.

General Alexander, you've been very candid. One of the things that jumps out at me about this report is that the prison is being shelled every day, it seems like. These people are in a war zone, so you could have the best-trained, highly-motivated people in the world, and this was just a tough job. But if you have poorly-trained people who were told they were going to go home, and had that yanked out from under them, and poor command, it's a cocktail for disaster. Do you agree with that?

General ALEXANDER. Yes, sir.

Senator GRAHAM. Okay. Part of this hearing—and I appreciate so much what the Chairman and Senator Levin have done by having these hearings—is to try to make sure that we get it right next time. Seven-hundred people guarding 7,000 at one time is not a good ratio, I don't believe. Do you have the men and women under your command necessary to, in a valid way, get MI gathered? Is it your opinion we have enough people in uniform in the Reserve component to act as MPs to prevent this problem in the future?

General ALEXANDER. Sir, that's a great question. Army transformation is at the heart of what you're getting to right now. I know that the Army leadership has been over here to brief that, but let me give it to you from my perspective, because it is important.

Today we have about 240 active duty interrogators. We will more than triple that under Army transformation and that key change and some of the other changes we make for our analysis and other areas to fight this new emerging threat is where our Army is going under that transformation, and that's very important to our country in the future.

So I would say that continue please, sir, supporting as you have that transformation process. It's vital to resolving this issue and others.

Senator GRAHAM. Chairman Warner asked a very good question in just simple terms, and give us an educated guess, because I know you don't know everything, what do you think happened in that prison between the MI community and the MPs?

General ALEXANDER. Speculation—

Senator GRAHAM. Just your gut feeling as a three-star general.

General ALEXANDER. I believe you had not only poor leadership, you had a group that were essentially leadership and controlled their environment on the midnight shift. Nobody came to check on them for periods of time and their leaders may have been absent at those times, and that other people came up and heard that some of this was going on, and they did things that were incorrect, reprehensible, and should be punished. If any leaders participated in that, they should receive the same punishment, and if anyone told them to do that, in my mind, they should receive the same punishment.

What we have to do, sir, is find out exactly who told them and what they did do, and I think that will come out.

Senator GRAHAM. One final thought. I think everyone here, Republican or Democrat, will make sure you have the resources necessary to gather intelligence in a lawful way to protect our troops to do your job, and we will look at retooling the military. We can learn from this experience.

But I would like to end on this thought. Senator Lieberman I think spoke to a lot of us here a few minutes ago. The beheading video is not only shocking, but it should be a wake-up call as to exactly who we're dealing with here. We're dealing with an enemy who has absolutely no boundaries, who's despicable in every way, and really behaves like animals in the name of God.

Our challenge as a nation, General Alexander, is to keep the fight going, vanquish this enemy, because losing is unacceptable to the international community. We learned one thing if nothing else from Hitler, one more country wasn't enough. You could never appease him, and we'll never be able to appease the folks we're fighting today. So for the international community, it is now time to join this fight. We have made mistakes, and I'll be the first to admit it, but the war itself is not a mistake. These people need to be controlled and vanquished, and in the process we need not become animals ourselves. That's what this is all about.

Mr. Chairman, I know we can do both of these things. We can vanquish this enemy and we can do it with honor, because we've done it before as a nation, just as we defeated Hitler working together, we can defeat these people. I believe that these hearings, no matter how bad it makes us look for the moment, is an opportunity for us to show the world that there is a better way, and I hope the people of Iraq will be watching and listening, because they need to have higher expectations about their future.

I appreciate you all serving our country and we will stay in touch.

Chairman WARNER. Thank you very much, Senator Graham, for those observations.

Senator Ben Nelson.

Senator BEN NELSON. Thank you, Mr. Chairman. We haven't ceded the moral high ground in this situation, no matter how bad the abuses are, no matter how many there were. We haven't ceded the moral high ground, no matter what we find out, as to who was involved, and as to what level. We will correct it, we'll prosecute those who have engaged in criminal acts, and we will hold everyone accountable no matter what their level of authority.

It will help remove the stain, but in the process of doing that, it's important that we don't create the opportunity for scapegoats or duck responsibility as it might be our responsibility to deal with, simply because it's painful, or it puts us all in a very difficult situation to deal with it.

So I have to ask this, General Alexander. As you look at your future investigations and current investigations, would you expect to find anything that would bear on the court-martial that are underway or about to get underway? Would there be any factual evidence that you might determine that would have any impact on those trials?

General ALEXANDER. Sir, I think the one key thing that will impact that is if someone in authority told them to do what they did, that has great impact. It does not condone it, but it clearly in my opinion is a mitigating factor. We have not found that.

Senator BEN NELSON. Will you find it, or do you know whether you'll find it?

General ALEXANDER. Sir, I don't know that it exists.

Senator BEN NELSON. That's what I mean. But if you don't know whether it exists, you don't know that it doesn't. I guess I certainly don't want to sweep anything aside, I don't want to put anything in limbo, but I am concerned that we're moving forward before all the investigations are complete and no one would want us to rush to judgment. It would also, I think, be inappropriate if we look like we're rushing to judgment.

General ALEXANDER. Yes, sir. I think the allegations, and I think this perhaps may be something that—

Senator BEN NELSON. I think you might want to pass it off to General Romig.

General ROMIG. I would say that it looks like that the cases are being moved very quickly, but you have to realize that the investigation started in mid-January, and so the chain of command has had the information as the investigation was developed.

Senator BEN NELSON. I agree. I shouldn't have used the word quickly as opposed to prematurely. That's, I think, what my concern is, and then as it relates to General Karpinski, it's my understanding that the MI may have taken over November 2003. Is that after the abuses that are in question here? I guess, General Alexander, you gave the time frame.

General ALEXANDER. Sir, she was given a report by the ICRC on November 6.

Senator BEN NELSON. About these particular abuses or the fact that there were abuses?

General ALEXANDER. About the fact that there were abuses and some of the abuses listed in there sounded the same as some of the abuses we're seeing. Now, what we have to do is get the exact dates of those. I do not have those.

Senator BEN NELSON. Would this have been by the midnight shift?

General ALEXANDER. Yes, sir.

Senator BEN NELSON. These abuses?

General ALEXANDER. Yes, sir. My understanding, because when you read in the ICRC, that one statement, you immediately think of that one picture, at least I do. Now, that report was given to her on 6 November, and as I said, the Fragmentary Order (FRAGO) took place on 19 November.

Senator BEN NELSON. Do we have any explanation from General Sanchez about why he interrupted the command by putting Colonel Pappas in place to deal with both the intelligence, and force protection side?

General ALEXANDER. Sir, it was just as you say. That General Sanchez wanted Colonel Pappas to move his headquarters to Abu Ghraib and take charge of the force protection. As was pointed out earlier, they were receiving artillery or mortar fire. People were getting shot. The facility is not being policed, and going along with the initiatives as quickly as he wants to. The MP battalion commander on the ground was not making that headway. He felt that by putting one of his senior commanders there, moving Pappas up to do that and putting him in charge of that, it was the correct thing to do for the soldiers and the detainees. So that is why I believe he made that decision.

Senator BEN NELSON. General Burgess, I'm sure you're familiar with the term, rendering detainees or prisoners in terms of shifting them off to other locations, other governments for intelligence-gathering purposes?

General BURGESS. Yes, sir, I am aware of the term rendering.

Senator BEN NELSON. Do you know of any instances where we've participated in that by sending any detainees or anyone within our custody to another country for any other purpose or any purpose?

General BURGESS. Sir, I am aware that we have currently kept individuals under U.S. Government control in terms of conducting interrogations. I am familiar, but it would not be appropriate to go into in this session and could discuss with the leadership another particular case, but it would not be appropriate here.

Senator BEN NELSON. I wouldn't want you to go into it, but you are aware it might be something we could take up in a secure environment?

General BURGESS. Yes, sir, but—yes, sir. That's all I'll say about it here.

Senator BEN NELSON. Thank you, Mr. Chairman.

Chairman WARNER. Thank you very much, Senator.

Senator Talent.

Senator TALENT. Thank you, Mr. Chairman. I had one question for General Romig. Before that, I'll comment on something Senator Collins said. I understand her saying that it's hard to believe how these enlisted soldiers would have known that this was the way to humiliate these particular prisoners. That actually is less of a question mark in my mind. Anybody who's worked in the civilian prison system or is relying on anybody who has, knows something about Islam, that's not uncommon, and I would think know something about how to humiliate people too, because unfortunately, that's not uncommon in the civilian prison system.

What is inexplicable to me, and I'd appreciate your comment even if you're going over old ground, is where the officers of this brigade were. If I ask myself what is unusual, truly incomprehensible about the conduct of these enlisted people is that they would have done this to this scale and with this documentation without having asked the officers in their direct line of command whether they should do it.

Now, maybe you know this and are not commenting on it because it's part of the cases, I don't know, but that to me is the true question mark here, because I'm not used to an Army operation where there seems to be such an abdication of the first rule of a chain of command, which is to know what is going on with those immediately beneath you. General, if you want to comment, go ahead.

General ROMIG. Senator, as you point out, it would be inappropriate with an ongoing investigation and criminal cases moving forward for me to comment on that.

Senator TALENT. This is the crux of what, at the appropriate time, I want to know about this, because I agree with you, General Burgess, that people can be pretty inventive even on their own in figuring out ways to do the wrong thing. But for them to take this on their own responsibility just seems to me to be extremely un-

likely, and the natural place they would have gone to check this out is their own chain of command, not somebody in MI.

General ROMIG, let me ask you a question that I raised with the panel this morning, and you can just maybe enlighten me because another side of this is, why, once General Taguba issued his report, it took so long to work its way up the upper level of the chain of command, and of course, everybody is talking about command influence, which I know is an issue. Now, could we maybe deal with this in the future by having a separate line apart from the chain of command for the purposes of court-martial and the UCMJ where you can report a special interest case? In other words, get it to the top through a separate line? I'm told the Air Force has this kind of an office. Are you aware of that? I have an all-green panel here so maybe you're not, but I mean, are you aware of that? Is this something the Army could look into?

General ROMIG. Sir, I'm not sure what you're exactly referring to.

Senator TALENT. It's called the Reporting Office on Special Interest Cases, and what I'm told is that you can go to this office if you think the case has some interest beyond the particular case for the policy of the Air Force, and you don't have to worry about command influence, because this office is not in the chain of command for those purposes.

General ROMIG. There's a difference, I guess, between reporting, which this was reported up, we knew about it in January, versus having the entire report up with all, as I've heard, 6,000 pages if you count the annexes. It's not necessary, I don't think, to have a full report if you're apprised of what's in the report, and that occurred much earlier. But this is something we ought to look at, you're right.

Senator TALENT. Yes, because if the higher level officers are caught between their responsibilities from a command influence standpoint and their desire to expedite this up the chain because of the effect on the mission and the strategy, then maybe we can do something to free them from that conflict.

General ROMIG. That's something that should be looked at, you're right, sir.

Senator TALENT. Thank you, Mr. Chairman.

Chairman WARNER. I thank you. We have to look at that. If you could take that on yourself to look at that situation—

Senator TALENT. We're looking at it in my office, Mr. Chairman. I'll talk to the staff of the committee about it too.

Chairman WARNER. When you sit here and say you knew about it in January, did you blow some whistles and alert people that we have a problem?

General ROMIG. Sir, I did not see the videos or the photos, but I knew of the case and that it was going to be a nasty case, had meetings with the Vice Chief of Staff and other leadership in the Army, so we were working the issue. But this was also—

Chairman WARNER. As early as January?

General ROMIG. Mid- to late-January, yes, sir. This was also in the context of tracking all the detainee abuses, which we started well before this.

Senator TALENT. Excuse me, Mr. Chairman, I asked Secretary Cambone this morning, and I think that what I can sense that

those at the top level saw this as a UCMJ-type situation and their command influence protocols cut in in their own minds, and they said, okay, we have to go by the book on this because we don't want to prejudice the prosecution, which is understandable, because you know how that's drilled into them. So maybe some separate reporting-type situation where we'd have people who would be more free to really rattle everybody's cage about it is the way we need to—we will look into it, Mr. Chairman.

Chairman WARNER. Yes, some assessment as to how it affects American, overall foreign policy, everything. We now have Senator Pryor.

Senator PRYOR. Thank you, Mr. Chairman. General Romig, I want to follow up if I may on Senator Graham's and also Senator Akaka's questions about contractors, and specifically, just for clarification, in your view, what rule of law applies to these civilian contractors?

General ROMIG. It depends on what they do. If they have committed an offense that, for example, a homicide or a serious assault, maiming of somebody, these would be prosecuted under Federal law, under the Military Extraterritorial Jurisdiction Act, brought back to the United States and prosecuted in Federal courts.

Senator PRYOR. By the Department of Justice?

General ROMIG. Yes, sir.

Senator PRYOR. Do you happen to know how many contractors were involved in this prison? Do you know how many—

General ROMIG. Sir, I have no idea.

Senator PRYOR. Do you?

General ALEXANDER. Yes, sir. There were 29 as I understand it, 8 interrogators, 10 screeners, 9 analysts, and 2 reports writers, so 29.

Senator PRYOR. So 29 civilian contractors?

General ALEXANDER. Yes, sir.

Senator PRYOR. Were they all with the same company or is that different companies?

General ALEXANDER. Sir, they were all with the same company. Now, those were the interrogators. There was also a linguist contract under another contractor type.

Senator PRYOR. Who had the bigger—the 29, who had that contract?

General ALEXANDER. That was CACI, sir.

Senator PRYOR. Okay. Who was the commanding officer there at the prison?

General ALEXANDER. Sir, right now today—

Senator PRYOR. No, who was it at the time?

General ALEXANDER. Sir, that was the report, so I want to make sure I answer this exactly correct. After 19 November, Colonel Pappas was the FOB commander. Prior to that, it was Lieutenant Colonel Phillabaum, who ran Abu Ghraib for the 800th MPs, and that was under General Karpinski.

Senator PRYOR. Great. General Alexander, you have mentioned, I think almost all witnesses have mentioned, discipline and leadership. Is it your conclusion that part of the problem there with the

discipline and the leadership is the failure to train or is it the failure to screen? Where does this start to break down?

General ALEXANDER. Sir, I can tell you from my experience when I was a lieutenant, one of the first things my platoon sergeants taught me to do was to visit the billets at all times day and night, so that's one of the first things you learn as a lieutenant is to go and see what your troops are doing day and night. We did that in Germany because of drug problems back then.

I think right there the question is, where was the leadership on the night shift? When did they come by and visit? That is, when people refer to a breakdown in the leadership, that's what forms in my mind.

Senator PRYOR. Does that go for training as well?

General ALEXANDER. Absolutely, sir. In training, it is laid out both in the CJTF orders about make sure your soldiers are trained on the humane treatment. That's specific in the orders. Sir, I think it was pointed out earlier that this was an internment, this is the duty of this unit. This was something that you are trained to do. That is the first basic thing that all noncommissioned officers and junior leaders know to do, and I can't answer why it was not done.

Senator PRYOR. Let me ask one last question or one last line of questions, and that is, understandably, in the last few days we've been very focused on the conditions in the prison itself. There have been some question today and previously about the qualifications for getting yourself into this prison, and we've talked about that a little bit. There's this ICRC Report that 70 to 90 percent were wrongly arrested and detained. We can—we don't know all the background on that, so I'm not going to ask about that. But my question is, once they're in the prison, from that point, where do they go? If you're going to prosecute these people or whatever decision you make, where do they go from here?

General ALEXANDER. Sir, the facility that is there at Abu Ghraib—and I'll let General Burgess add in here if I state anything incorrectly—has three areas, a general detainee population area, an Iraqi criminal area, and then this JIDC. The general population is where most everyone is brought in who is captured by our troops who are doing something against our soldiers or we believe, or against Iraqi civilians. The criminals are the ones who are brought in for criminal acts, and that is now under Iraqi control.

The JIDC is where personnel who are of intelligence value are placed because they either participated in an act against our forces or know something that is important for the priority information requirements that the commanders have.

Senator PRYOR. There's a report, and forgive me, but I can't remember if it's in The Washington Post or exactly where I saw it, that talks about, it says the Americans have established a secret court. I was curious about this central criminal court of Iraq and what exactly is that and how does that work. I assume some of these prisoners there would be tried in that court. Could you elaborate on that?

General ALEXANDER. I guess it's a secret court because I'm not aware of it, sir, I really, truly am not.

General ROMIG. Sir, that's—I wouldn't really characterize it as a secret court. It's a court that functions within Iraq for criminal

cases, serious criminal cases. One of the things, sir, I wanted to point out was that these individuals undergo a 6-month review. If the feeling is we need to continue to detain them, at the 6-month mark, a review and appeals panel reviews and makes recommendations for their release if they feel they should be released. That goes up to Baghdad to an appeals board that is chaired by some very senior officers.

Senator PRYOR. Thank you. Mr. Chairman, that's all I have.

Senator SESSIONS [presiding]. I'm proud to be a representative of the people in a country that takes these things seriously, that believes in truth and facts, honor and duty, and responsibility, and we're all humans and we frequently all of us fail. There have been some failures here. We're going to get to the bottom of it, and I appreciate your candor, all three of you, as we go forward, and I most of all appreciate the great service of our soldiers under very stressful conditions at this very moment, because this Senate and this Congress voted to send them there by a three-fourths majority vote. If anybody thought that everything was going to go smoothly, they're not worthy of the office of United States Senator, because anybody that knows history knows that there will be problems.

But we don't believe in them, we believe in eliminating them, and I'm just proud of the way you've responded to date. The beheading that we hear about, I pray it's not true. If it is true, it would not be untypical of what we're seeing in the enemy that we're facing. They are not going to have their own internal inquiries and they're not going to condemn these actions because they justify these actions and they believe in them.

One of the things I think it's important for us to remember and I just want to get straight, maybe General Alexander, of this MP unit, is even last year four members were submitted to court-martial for abusive procedures, were they not?

General ALEXANDER. Sir, I'm not aware of that.

General ROMIG. That may be correct, sir. I'd have to double check.

Senator SESSIONS. I think it's in the report, referred for court-martial. I'm not sure how that came out, but they were disciplined for abusing prisoners last year, which means, number one, I'm glad somebody in the unit took charge of it, number two, the military's not tolerating this. I have not forgotten a very fine brigade commander who, in a combat situation, lost his discipline and fired a gun by an Iraqi's head, thinking he had to have information. He was removed from the service, basically, and a spotless record otherwise, because the military did not tolerate this kind of activity.

I'm also aware that within 1 day of this specialist, not an officer, a specialist coming forward, an investigation was opened under the CID. General Romig, that's what you do to prosecute people, take them to court-martial and put them in jail with, is it not?

General ROMIG. Yes, sir.

Senator SESSIONS. So that was commenced the next day. Can you tell me, any of you, about the suspensions? I know we've talked about the Brigadier General in charge of the brigade, but there's been some actions within a few days of this report to actually remove people from their official position, not privates, not people out there at the lowest level who were in the photographs, but officers

of substantial rank. What can you tell me about that, General Romig?

General ROMIG. Yes, sir. The battalion commander received a general officer memorandum of reprimand and was relieved for cause.

Senator SESSIONS. Within a week perhaps?

General ROMIG. Sir, I could get the time frame. I just don't have it in front of me.

Senator SESSIONS. It was a short period of time, as I recall.

General ROMIG. Yes, sir. After a chance for the command to review the evidence and the facts. There are a number of folks that they're waiting for their rebuttal on their general officer memorandum of reprimand. An operations sergeant major was relieved with a general officer memorandum of reprimand, so there were a number of actions taken, and all of these are very significant actions to a person's career obviously.

Senator SESSIONS. That was long before any news media, any Congress got involved in this. Sometimes I think this Congress reminds me, in this instance particularly, of the little dog that chases an automobile down the road barking and thinks it ran the automobile off. Like we were demanding you do something, you've already done it.

Let me ask about this MP situation, General Alexander, and I think it was somewhat confusing about the chain of command and the orders. As I understand, Senator Levin indicated there was some evidence. I think as the good lawyer he is, he was correct. There was some evidence that perhaps MI personnel had done wrong. Is it your opinion that there was not persuasive evidence, and if not, why?

Let me just ask you, are you saying to us that you were not persuaded by the evidence that you've seen to date that any of these MI people authorized anything like this?

General ALEXANDER. Sir, that is a good statement and I appreciate the opportunity to clear it up, because I have not seen any indications that a person in the intelligence chain of command told them to take these activities on. There are numerous statements, as you point out, that allege MI officers, which could be any of the people there, told them to do this. We need to find out the specifics and the facts of that, wherever that may lead this.

Senator SESSIONS. I agree with that. We need to follow that up where it leads. I will say, as a person who's been involved in prosecutions for over 15 years, in fact, they didn't get any names and specific allegations, and I believe the phrase was insinuated, that these officers insinuated this or that does cause me some concern. If somebody had told me to do something and you were complaining to me about it, I'd say this person told me to do it and I'd give the name.

But I think we do need to follow that up. I don't believe that the MI deserves any pass on this in terms of an investigation, I don't think you do. I do think it's quite possible that an MP working in that prison, if they had been, if it had been suggested they do these kind of things, may have felt they had some authority or ability to do so.

Senator BILL NELSON. Senator Sessions?

Senator SESSIONS. Can you share any more with us on that?

Senator BILL NELSON. Did you know we're in a vote and we have 3 minutes left?

Senator SESSIONS. I did not, and my time just ended 1 minute ago.

Senator BILL NELSON. I need to go and vote.

Senator SESSIONS. I do too.

Senator BILL NELSON. So if you're chairing the meeting, would you recess it until we can get back?

Senator SESSIONS. Senator Nelson, that is a brilliant suggestion.

Senator LEVIN. Mr. Chairman?

Senator SESSIONS. Oh, Senator Levin, you want to chair it for us?

Senator LEVIN. There's someone else coming back here as well, so we'll keep it going if that's all right with you.

Senator SESSIONS. I would just try to follow up on that. I think we need to know that. I think we need to know if there were any suggestions that, going beyond these interrogation ROE, which I think makes sense, occurred. Also, I'm aware, General Alexander, that this was a dangerous place to be, and our soldiers were at great risk, and this Congress, we're on the top defense officials and military people to get more intelligence, because we said repeatedly good intelligence saves lives, and so I know there's a great pressure on.

Are you satisfied now that since January and since these things have arisen that we've gotten our people back on the right side of that line if they ever got across of it? Are they clearly informed now where the line is, what is legitimate for them to do in interrogation, and are they on the right side of it?

General ALEXANDER. Yes, sir. I am convinced we have taken those actions.

Senator SESSIONS. It seems to me we have at least five investigations ongoing on policies. Our policies are being reemphasized and I think we're on the right track, and I believe that is what a good nation does that has high ideals. If they mess up, they get themselves straight, but we don't give up on the mission that we're undertaking, which is noble and honorable and going to be a great improvement for the lives of the people of Iraq. Senator Levin.

Senator LEVIN. Thank you. I was going to have some additional questions in the second round.

Senator SESSIONS. You're available to commence the questioning if you would like.

Senator LEVIN. We might as well start a second round before the first round is over and save some time later on, if that's all right with you, Mr. Chairman.

Senator SESSIONS. I think it makes sense.

Senator LEVIN. Thank you. First of all, let me ask you, General Romig, about this interrogation ROE that require the commanding general's approval. In your opinion, are those actions and activities, including stress positions, sensory deprivation, and so forth, consistent—not consistent with—would the Geneva Conventions say that those are okay?

General ROMIG. Sir, this is the first that I've seen of these. They were—the legal review, as I understand, was done down at CJTF—

7, but if I'm not mistaken, these are taken out of your FM, is that correct?

Senator LEVIN. Could you tell us which FM that is? We're having trouble finding that FM. What's the date of it, that field manual?

General ALEXANDER. Sir, it's FM 34-52.

Senator LEVIN. What's the date of that?

General ALEXANDER. Sir, it's 1984, I believe. No, 1992, I'm sorry.

Senator LEVIN. What page are you on?

General ALEXANDER. Sir, I'm on the date where these are, they're on 3-16 roughly.

Senator LEVIN. So those specific items are listed in that FM?

General ALEXANDER. Yes, sir.

General ROMIG. Sir, the point I was going to make is those get an exhaustive legal review to ensure that they're appropriate and consistent with the conventions, international conventions, the field manuals do.

Senator LEVIN. That protected persons under the Geneva Conventions can be subjected to these, is that what you're saying, General?

General ROMIG. Again, sir, I have to fall back on the prior legal review that was much more exhaustive than my taking a look at right now, and saying that if that's the case, yes, I would concur with that.

Senator LEVIN. General Alexander, can you tell us who the lawyer was who said that these items are consistent for protected persons, that these are allowed to be applied to protected persons under the Geneva Conventions?

General ALEXANDER. Sir, I don't know the lawyer's name on that. I do know that that was done, as General Romig said, at CJTF-7. It is consistent with our FMs, so I don't know who, which lawyer at CJTF-7, but we can take that for the record.

[The information referred to follows:]

The Interrogation Rules of Engagement Chart was prepared by the officer-in-charge of interrogation operations at Abu Ghraib prison. It was intended as a graphic aid to assist interrogators in determining what interrogation approaches they could or could not use without higher approval. It was informally reviewed by the 205th Brigade Judge Advocate and attorneys assigned to the Office of the Staff Judge Advocate, CJTF-7.

Senator LEVIN. That would be within the last year or so?

General ALEXANDER. Yes. That part there where these are laid out are also laid out in the guidance from CTJF-7 on their interrogation operations.

Senator LEVIN. So this would be within the last how many months?

General ALEXANDER. Sir, those came out when the CJTF was stood up in July, and we have copies of those and their standing orders that came out.

Senator LEVIN. Just so I can be real clear again, that FM specifically lists these items with the same words?

General ALEXANDER. No, sir. In fact, I'll give you the manual, a copy of the manual to leave here with the committee.

Senator LEVIN. That would be very helpful, but my question is, does the FM say specifically that you can apply stress for up to 45 minutes?

General ALEXANDER. No, sir, it does not say you can apply stress up to 45 minutes. It says on here, and this is where the lawyers have to get involved, just as you say, sir, and I understand you're a lawyer, so I feel I'm on the short end of the stick.

Senator LEVIN. No, no, I won't either use that or misuse that. I'm not sure it's even a plus.

General ALEXANDER. What it says here in the manual is that you can't use stress positions for a prolonged period of time is exactly what it says.

Senator LEVIN. So that's been interpreted by a lawyer to mean up to 45 minutes?

General ALEXANDER. Yes, sir.

Senator LEVIN. Unless you get something approved in writing and then it says sleep management, and what are the words in the manual, about 72 hours without sleep?

General ALEXANDER. It says abnormal sleep deprivation, examples of mental torture include abnormal sleep deprivation. I understand that at the general counsel's, as they convene to look at what sleep deprivation, and again, that would go on, but they looked at exactly, okay, so what is sleep deprivation, is that 16 hours in a day, and so they went through that and those are the periods, and you can see that because those have caveats in the FM, those are the ones that General Sanchez personally had to get involved with.

Senator LEVIN. No, I understand that, that's if it's more than 72 hours, but I'm talking about the——

General ALEXANDER. Sir, it says 72 hours——

Senator LEVIN. You're correct. What are the words in the manual about sleep management or sleep——

General ALEXANDER. Abnormal sleep deprivation.

Senator LEVIN. So have you seen the legal opinion that interprets that to mean you can do sleep management up to 3 days with the commanding general's approval?

General ALEXANDER. No, sir, I have not seen the legal opinion——

Senator LEVIN. That supports that.

General ALEXANDER. That supports it exactly like that, but I do know that both they and a larger one was done for the DOD.

Senator LEVIN. All right. If you could get that for us, I'd appreciate it. Have you seen that, General Romig?

General ROMIG. No, I have not, sir.

[The information referred to follows:]

"Sleep deprivation" is not an approved interrogation technique in U.S. Army Field Manual 34-52. In January 2003, the Secretary of Defense directed the DOD General Counsel to establish a working group to review various interrogation techniques for use in operations at Guantanamo Bay, Cuba. The concept of "sleep deprivation" as an interrogation technique was addressed in the Working Group. Their analysis, however, was limited to possible techniques for use on unlawful combatants in Guantanamo. It did not address operations in Iraq. After considering the Working Group Report, the Secretary of Defense approved interrogation procedures in April 2003 that did not include "sleep deprivation." As previously noted, the chart prepared at Abu Ghraib prison was informally reviewed by the 205th Brigade Judge Advocate. I have been informed that sleep deprivation, or "sleep management" as it is delineated on the chart, was never requested nor approved for use by the Commanding General, CJTF-7.

Senator LEVIN. Thank you. Now, on the ROE, this document here, it's been declassified, in effect, I guess, since the charts have

been used already. Apparently CENTCOM did not approve the initial draft of these ROE. Do you know anything about that?

General ALEXANDER. No, sir.

Senator LEVIN. The ICRC report, page 3.2, called MI section, and paragraph 27 under that section says the following, that: "the ICRC visited people at the Abu Ghraib correctional facility. They witnessed the practice of keeping persons deprived of their liberty, completely naked in totally empty concrete cells and in total darkness allegedly for several consecutive days. Upon witnessing such cases, the ICRC interrupted its visits and requested an explanation from the authorities. The military intelligence officer in charge of the interrogation explained that this practice was 'part of the process.'"

Did you see this before I just read it to you?

General ALEXANDER. Yes, sir.

Senator LEVIN. Does that trouble you?

General ALEXANDER. Absolutely, sir.

Senator LEVIN. Would that be evidence that the MI officer in charge of interrogation had something to do with this process?

General ALEXANDER. Clearly, that's one of the individuals we would like to know who that was, specifically what is his name or her name so that we can take action. Sir, you point out a good question, a good point. As soon as we know that, we should begin an investigation.

Senator LEVIN. No, you should begin an investigation to find that out.

General ALEXANDER. Yes, sir.

Senator LEVIN. That's a lot different. You said as soon as you know that you should begin an investigation. I would hope you're investigating to find out who these folks are. There's all kinds of evidence that MI is involved here. We have the statements in General Taguba's report over and over again referring to MI people. Sergeant Davis stated he'd heard MI insinuate to the guards to abuse them. When he said, what did MI say, he said, loosen this guy up, make sure he had a bad night. The rest of the wings, according to this witness, are regular prisoners and 1A, 1B, are MI holds. Was that your understanding that 1A and 1B are MI holds?

General ALEXANDER. That's my understanding, yes, sir.

Senator LEVIN. Does anybody here on this panel know what Secretary Rumsfeld meant when he said the Geneva Conventions did not apply precisely to Iraq? That's clearly the context that he was referring to on that date, back on May 5.

[The information referred to follows:]



United States Department of Defense.

News Transcript

On the web:

<http://www.defense.gov/cgi-bin/dlprint.cgi?http://www.defense.gov/transcripts/2004/tr20040505-sec>

Media contact: +1 (703) 697-5131

Public contact: <http://www.dod.mil/faq/comment.html> or +1 (703) 428-0711

Presenter: Secretary of Defense Donald H. Rumsfeld

Wednesday, May 5, 2004 7:14 a.m. EDT

Secretary Rumsfeld Interview with Matt Lauer NBC "Today"

MATT LAUER: Secretary of Defense Rumsfeld is at the Pentagon this morning.

Mr. Secretary, good morning to you. Thanks for joining us.

RUMSFELD: Good morning.

LAUER: I don't know if you were able to hear Senator Biden as he was talking just now. I know you were just sitting down. But he basically says he wants to know what did you know and when did you know it. When did you find out about the abuses taking place at Abu Ghraib prison?

RUMSFELD: The first indication that the Department of Defense received was, I believe, on January 13th, when a soldier who saw some abuses taking place, apparently, reported them up his chain of command to his superior out there in Baghdad area. And the Central Command, the United States military command there, made an announcement to the world January 16th indicating that the charges of abuses had been made and that an investigation had been initiated by General Sanchez.

LAUER: And the investigation – the report by General Taguba was completed – the date I have is March 9th. And yet, when questions really started to be asked about this last week, General Myers, General Kimmitt, I asked, and you, as of yesterday, said you have not yet read the full report on this, and from what I understand from your comments, hadn't seen the pictures of this abuse until they aired on CBS last week. Why did it take so long for a report of such gravity to make its way up the chain of command?

RUMSFELD: Well, first of all, the report, as I understand it, is a stack of a report coupled with a whole series of annexes. And so when I'm asked a question as to whether I've read the entire report, I answer honestly that I have not. It is a mountain of paper and investigative material. Second –

LAUER: But in general terms, were you aware –

RUMSFELD: Just a minute. Just a minute.

LAUER: -- of the abuses taking place prior to that?

RUMSFELD: Just a minute. I'm going to respond to your question.

Second, the report and the information was part of a criminal investigation. And when there's a criminal investigation, as you know, whether it's in the military or outside the military, those things are managed in a prosecution or prosecutorial mode, and the materials are pretty much kept within that chain.

Third, the information about the abuse led to the investigations from a management standpoint that were initiated almost immediately, and then sequentially thereafter to the point that there are six different aspects of it that

have been looked into.

The system worked. And it was announced publicly. There was no secret about it. They went right before the world in Iraq and told the Iraqi people, the American people, everyone, "Be on notice. There have been these charges made." So it worked.

LAUER: When you say the system worked, you're talking about the system of investigation. Clearly there are parts of the system in place in the prisons in Iraq that are broken. The military report calls these incidents, quote, "horrific abuses."

RUMSFELD: Indeed.

LAUER: It continues to say they were, quote, "wanton acts of soldiers in an unsupervised and dangerous setting." So who, Mr. Secretary, is ultimately responsible for that unsupervised and dangerous setting?

RUMSFELD: Well, clearly it's the United States Army and the Central Command have the responsibility for the management of the prisons in that part of the world. And they are determining responsibility at the present time. And there have already been some criminal actions undertaken.

LAUER: Reserve Brigadier General Janis Karpinski has said - and she's the person who was in charge of the prisons in Iraq - and she said that the cell block where these abuses took place at Abu Ghraib was off-limits to everyone, including her. Again, she's in charge of the prisons there. She's a general. How could that be?

RUMSFELD: There's two aspects to the facility there at Abu Ghraib. One aspect, of course, is detention. It's keeping people off the street so that they can't go out and commit a criminal act.

A second aspect is interrogation, and it's asking people questions to try to glean information that can save the lives of American soldiers in Iraq. And one aspect of it is handled by the people who handle detention and another aspect is handled by the people who handle the process of asking questions to try to save the lives of American soldiers.

LAUER: But can the people who handled the asking questions aspect of it really tell a brigadier general that she cannot have any access to that cell block?

RUMSFELD: Those are legal questions that are being studied in the investigation and determined to try to assess responsibility and culpability.

LAUER: Let me read you something from the Washington Post in their editorial this morning. It says, quote, "A pattern of arrogant disregard for the protections of the Geneva Conventions or any other legal procedure has been set from the top by Mr. Rumsfeld and senior U.S. commanders." What's your response to that?

RUMSFELD: Well, it's not accurate. The fact of the matter is that from the very outset, the decision was made by the government of the United States that the people detained would not be treated in a manner that was - (correction?). The decision was made that the Geneva Convention did not apply precisely but that every individual would be treated as though the Geneva Convention did apply. And as a result, the provisions of the Geneva Convention were the basic rules under which all people were detained. So it would not be accurate to say what that editorial said.

LAUER: When you said, though, in February of 2002, and I'm quoting, "The set of facts that exist today with the al Qaeda and the Taliban were not necessarily the set of facts that were considered when the Geneva Convention was fashioned" - again, in February 2002 - by questioning the relevance of the Geneva Convention in certain circumstances, with al Qaeda and the Taliban, have you laid the foundation for the atmosphere in which these abuses may have occurred?

RUMSFELD: Certainly not, because in close proximity to what you quoted, I think you'll find the statement I just made, that the United States government, the lawyers, made a conscious decision and announced it to the world and announced it to all the people engaged in the detention process that these people would, in fact, be treated as though the

Geneva Convention did apply.

LAUER: When the president went to Iraq, he took the moral high ground. He said, "Look, Saddam Hussein is abusing and torturing the Iraqi people. We can provide a country where the Iraqis don't have to live in fear." You've talked about the war of ideas. How do these photos, how do these incidents, impact that war of ideas?

RUMSFELD: Harmful.

LAUER: Just one word?

RUMSFELD: Well, I've responded. I don't know what else one can say. There's no question that when any citizen, soldier or civilian, breaks the law, abuses people in a manner that's inconsistent with the way people are trained and taught and with the way decent human beings behave, then that's harmful to the United States.

LAUER: Real quickly, Mr. Secretary, if you will, would you support a congressional hearing into this? Would you testify before that hearing? And would you issue a formal apology to the Iraqi people for these abuses?

RUMSFELD: Well, anyone who sees the photographs does, in fact, apologize to the people who were abused. That is wrong. It shouldn't have happened. It's un-American. It's unacceptable. And we all know that. And that apology is there to any individual who was abused. It seems to me that these things have occurred. The task for me, as the responsible person in the Department of Defense, is to see that if it's an isolated instance that it's punished under the Uniform Code of Military Justice. If it's systemic, if there's something broader than that, obviously we have to undertake the kinds of investigations we're taking to see if other individuals conceivably have behaved that way.

LAUER: And real quickly - I've only got 10 seconds left, Mr. Secretary - you say if it's an isolated incident. There are some 20 other investigations ongoing now about possible cases of abuse. Are you convinced it's an isolated incident?

RUMSFELD: Of course not. We wouldn't be conducting these investigations if we thought we knew the answers. We don't know the answers. And that's why, starting last January, at the first indication of this, these investigations were initiated.

LAUER: Secretary of Defense Donald Rumsfeld. Mr. Secretary, I appreciate your time this morning.

RUMSFELD: You bet.

Senator LEVIN. Do any of you know what he meant? General Romig?

General ROMIG. No, sir. I did not hear that quote, but I do not know what he meant either. I do know that I had a discussion with some folks at DOD a day ago, and their view was, DOD general counsel, that it did apply.

Senator LEVIN. But in your judgment, does the Geneva Conventions apply precisely to Iraq?

General ROMIG. Yes, sir.

Senator LEVIN. General Alexander, do you know what the SECDEF possibly is referring to in the month of May of this year? He says the Geneva Conventions do not apply precisely. Do you have any idea what he could be referring to?

General ALEXANDER. Sir, I did not hear the context of what he said, so, sir, I can't comment on that.

Senator LEVIN. Can I ask one more question?

Chairman WARNER [presiding]. Sure.

Senator LEVIN. I will ask you, General Burgess, do you know what the SECDEF meant?

General BURGESS. No, sir, I do not.

Senator LEVIN. Secretary Cambone could not tell us either this morning. He said he would try to find that out, but it's pretty significant when the SECDEF does not even—or put it this way, states with great ambiguity and confusion what the rule of law is relative to the treatment of prisoners in Iraq. You can understand,

it seems to me, how that confusion could filter down to the lowest levels.

Now, there was an order on November 19, 2003, effective immediately, commander of the 205th MI brigade assumes responsibility for the Baghdad confinement facility and is appointed FOB commander. So the commander on November 19 of that facility is the commander of the MI brigade. So those MPs are taking orders, at least on one chain of command, from the head of the MI brigade. Is that correct?

General ALEXANDER. Yes, sir, for the security, as I understand it, for the security of the facility and for the initiatives that General Sanchez had to fix it up.

Senator LEVIN. But that's their mission, is it not?

General ALEXANDER. But it was not for the detainee operations. As I understood, that stayed with the MPs, but that's something that has to be clarified, and we need to get you that.

Senator LEVIN. You're saying that the what of the—

General ALEXANDER. The security of the detainees, which is inherently an MP mission, stayed with the MPs, as I understand it. There's two parts, sir, if I could just add to this. I think the timing of the date is also important, and the reason I bring up the timing is the 19th, the first ICRC report that went to General Karpinski happened on the 6th, so I believe that what General Sanchez was doing was to try to fix the force protection issues at that FOB.

Senator LEVIN. Let me read you the last line. It says, "units currently at Abu Ghraib are TACON to the 205th Military Intelligence Brigade for security of detainees." That's what it says. So they're taking orders, those MPs are taking orders relative to the security of detainees from the commander of the 205th Military Intelligence Brigade, are they not?

General ALEXANDER. On the 19th—

Senator LEVIN. And after the 19th.

General ALEXANDER. After November 19, yes, sir.

Senator LEVIN. So that's who they're getting orders from. So why is there any doubt in your mind that we ought to go to the—up that chain of command to find out how it is that these MPs were performing these actions without the knowledge, control, of the people in their chain of command, which is the MI brigade commander. That's the right person to look to, isn't it?

General ALEXANDER. Yes, sir, if they occurred after the 19th.

Senator LEVIN. Of course.

General ALEXANDER. If they occurred before, and we have indications that at least the ICRC report was given to General Karpinski on the 6th, and those took place in October, so that's where the difference is.

Senator LEVIN. After the 19th—

General ALEXANDER. Absolutely.

Senator LEVIN.—that's where you look.

General ALEXANDER. Yes, sir.

Senator LEVIN. To the MI brigade commander before the 19th otherwise. Got you.

Chairman WARNER. You're next, Senator, but let me just finish up the colloquy that the Senator and I were having here before you

arrived. That FRAGO of the 19th was the subject of a lot of discussion. It was issued by General Abizaid, is that correct?

General ALEXANDER. No, General Sanchez.

Chairman WARNER. Which he had perfect right to do it. What concerns me is were you asked to chop on it, because you're looking at the worldwide picture, you're looking at all of the combatant commanders. You're looking at SOUTHCOM, which is running the Guantanamo operation and if this departed from what you're doing in other commands, it seems to me that's troublesome.

General ALEXANDER. Sir, it actually was consistent as a matter of fact with what was done during Panama—or excuse me, during Haiti.

Chairman WARNER. During Haiti?

General ALEXANDER. Yes. In Haiti, the battalion commander had responsibility over that prison facility and the MPs there.

Now, you asked the question of why did General Sanchez not chop that through me. But, sir, it would not normally come back to the Department, because we aren't in that chain per se.

Chairman WARNER. I know people are ducking and running from that chain, but you're the chief of intelligence, you're the Lieutenant General, you're looking after all your people all over the world, you train them. It seems to me the combatant commanders should have an affirmative responsibility to keep you informed about your sphere of responsibility in the Department of the Army. The ICRC Report went into details about allegations of your people performing acts inconsistent with law and regulation, am I not correct?

General ALEXANDER. Yes, sir.

Chairman WARNER. That should have been brought immediately to your attention in my judgment, whether it's CENTCOM, SOUTHCOM, PACOM, or whatever command it is. But it's not the case, that is not the procedure?

General ALEXANDER. That's correct, sir.

Chairman WARNER. Then this committee's going to look into that, because we cannot have these—I call them symptoms—out here, which I understand we put them together in Goldwater-Nickles operating in such a manner that headquarters here in Washington with individuals of your rank in important positions having overall examination throughout the whole of the globe not knowing about it. For example, General Fast. This committee was asked to expedite her promotion from one star to two stars, and literally we agreed to have her jump over ahead of others who were in the normal order of promotion to two stars. I met her over there on my trip this summer and I was impressed. Now, she was the J-2 officer for General Abizaid, is that correct?

General ALEXANDER. General Sanchez, sir.

Chairman WARNER. I mean General Sanchez, I understand that. Does she keep you informed as a part of her responsibility of what's going on in that command?

General ALEXANDER. Sir, clearly we talk a lot, we do.

Chairman WARNER. But is there any formality by which she has an obligation to keep you advised?

General ALEXANDER. No obligation, sir, other than in terms of resources, outfitting, and training, we clearly have that responsibility, and for policies where they fall short. So for fixing the capabili-

ties in Iraq, that is a responsibility that we have for all our soldiers, and so in that we looked at what were all the problems, and sir, we came up with 127 different areas that we needed to fix, some of which fell into that human intelligence area. That was briefed back by me to both General Fast and General Sanchez and then that is something that we here at the headquarters and throughout the Army are working quickly to fix those, and we fixed about 123 of them.

Chairman WARNER. But the training fell down in these allegations. Your intelligence people were trained according to your manual presumably, but it collapsed, and it seems to me that should have been reported back to you ASAP that somehow all of the indoctrination and training, which presumably these MI people had, didn't function.

General ALEXANDER. You bring out another good point, sir. We did the training and doctrine command for the Army, did send teams over to Iraq on intelligence support to counterterrorism interrogation training, and that went on from early October 2003 for about a month and a half, along with another set of courses we talked about earlier called tactical questioning. So those mobile training teams were both established to go overseas to hit our divisions and then have hit units here.

Chairman WARNER. So you're saying they were training at the very time that these wrongful acts were taking place?

General ALEXANDER. Throughout Iraq, not necessarily at Abu Ghraib, but through the units—

Chairman WARNER. Throughout Iraq.

General ALEXANDER. Throughout Iraq, yes, sir.

Chairman WARNER. Senator Bill Nelson.

Senator BILL NELSON. Mr. Chairman, I want you to recognize Senator Clinton, because she was before me, but I think you're on to something. I want to develop it when it comes my turn. I think Senator Levin is on to something and that needs to be further developed.

Chairman WARNER. Senator Clinton.

Senator CLINTON. I thank my friend and colleague. I don't think that's the right order, but I won't argue about it. Mr. Chairman, I first want to thank you for your leadership of this committee. The last 2 days have been extremely challenging, and in every way you have given tremendous leadership. Of course I thank our ranking member who's been by your side the whole time. This is not anything any of us would wish on our Army or on our Senate or on anyone in any administration, but it comes to us to try to deal with this and to understand it as best we can, and I thank each of you for the time you've spent with us this afternoon.

Chairman WARNER. I thank you, Senator. To the extent that Senator Levin and I have given this particular series of hearings, leadership has been highly dependent on the total cooperation of every single member. We've had 100 percent attendance of our committee for 2 days.

Senator CLINTON. Gentlemen, I am still trying to understand exactly what some of the testimony we've already heard actually means. When General Sanchez on November 19, 2003, issued what has been referred to as a FRAGO effectively placing Abu Ghraib

under TACON of the 205th Military Intelligence Brigade, is that the only instance in which General Sanchez placed any other military—any other facility under MI command?

General ALEXANDER. Yes, ma'am, because I think that's the only place where there is a MI unit of that capability under him, so that's the only place, there is only one. It is the 205th.

Senator CLINTON. So that intel—when you say MI unit, you're talking about the 205th, right?

General ALEXANDER. MI Brigade, yes, ma'am.

Senator CLINTON. MI Brigade. They were solely assigned to Abu Ghraib?

General ALEXANDER. No, they were not solely assigned. They were subordinate to General Sanchez as the theater, the core level brigade that they have for the theater of Iraq. Their headquarters was about 20 miles south of Abu Ghraib, and he was the closest senior tactical leader that General Sanchez had to go in and fix what he saw as severe force protection issues at Abu Ghraib.

Ma'am, I would have done the same. I think the force protection issues that he had, the fixing of the facility for both our soldiers and the detainees were things that he saw were languishing.

Senator CLINTON. General Alexander, may I just clarify that for my own understanding? When Secretary Cambone testified this morning, he said that the 205th Military Intelligence Brigade under Colonel Pappas, as I recall, was given control of the facility, but not of the MPs. That struck me as a distinction without any meaning. Was Colonel Pappas put in charge of the facility under General Sanchez's order?

General ALEXANDER. As I understand it, and this is one that I said early on we need to take for the record to get General Sanchez's language on here exact, as I understand it in my discussions with General Sanchez, is that what Colonel Pappas was put in charge of was this facility of Abu Ghraib, which had the prison, it had the living area for the soldiers, it had the feeding area, it had the perimeter security, it had the MP detention area, it had an Iraqi criminal area, and it had a JIDC.

So this whole base, very much like Fort Drum, but smaller, this base, the garrison commander, and that's the distinguish that I think Dr. Cambone tried to make, the one responsible for fixing the garrison of Abu Ghraib was removed from the MP to the MI battalion commander. I do not believe that it was General Sanchez's intent to take the security detainee of those other detainees and say to Colonel Pappas, you also tell the MPs how to do detainee operations. I believe that was not—and his comments to me said that, but we need to get his statement for you on that, because I think he was the commander on the ground who made that decision.

Senator CLINTON. That would be very helpful. Also, as I'm piecing together the chronology, the order by General Sanchez apparently flowed from a set of recommendations from General Miller, is that correct?

General ALEXANDER. No, ma'am, it did not. Although your chronology is correct in terms of General Miller was there from August 31 to roughly September 9, there were a series of incidents of force protection, and I think it's important to note that Abu Ghraib was totally almost demolished in many areas before the first of August

so that the engineers had to go in and build it. That part of building it up is some of the stuff General Miller got to there, the actual compound for detaining these folks was at what was called Old Camp Cropper, the Old Camp Cropper area, and then that was moved, those folks were moved as they opened this up from the mid-August to mid-September time period up to Abu Ghraib, which became the theater holding and became the JIDC.

When General Miller went there, the concerns that he had, as General Burgess has brought out, was intel fusion, synchronization, the flow of information, and how you work together as a team to accomplish the mission. Nowhere in my military experience have I ever seen it where a MI person goes down and tells an MP that we soften the units up and that's good behavior. That is totally wrong. We ought to find out if anyone did say that, hold them accountable.

Now, in October, there was a series of ICRC visits throughout Iraq and two times they visited Abu Ghraib. It was those statements that came out in that document that you've seen that was given to General Karpinski in a draft form for her to respond on December 24, so that was November 6. So, as you look at the sequence of events, there was a series of mortar attacks and persons injured that went on through early November that I think led General Sanchez to say, I have a responsibility to protect my forces, you're not moving out fast enough, Pappas, I want, Colonel Pappas, I want you to move your unit up there and take charge for that force protection mission and for getting these initiatives, the quality of living for those soldiers fixed, and ma'am, you're familiar with that quality of living because it's the same thing we would say for our soldiers at Ft. Drum. If we put them in—they didn't have heat up there—being familiar with in New York State—if you don't give them heat and they are living in barracks without heat and the garrison commander went 2 months without having heat, he'd be out of there and you'd put a new one in charge.

I think that's what General Sanchez did, and I think that was clearly—I think it is being read into the events that General Miller said these nefarious things that caused this to happen. Ma'am, I do not see that, and I do not believe that is correct.

Senator CLINTON. Thank you.

Chairman WARNER. Thank you very much, Senator Clinton, for those helpful comments. Senator Nelson, you've been patient.

Senator BILL NELSON. Mr. Chairman, if I could get Senator Levin's attention.

Senator LEVIN. You have it.

Senator BILL NELSON. It seems to me that we have a revelation here that the two of you as our leaders have discovered that there was a military intelligence unit after November 19. When you juxtapose that then upon the testimony this morning, where there was a difference of opinion between General Taguba and Secretary Cambone. General Taguba said he was clearly under the impression that MI had direction over the MPs there. Secretary Cambone said no, that they didn't.

So with the information that you've gotten here, I think it's starting to clarify, and the question I would have, and I wish Secretary

Cambone was here, is why does he have a different impression? Let me ask you this.

Chairman WARNER. I think it would be proper if you were to pose that question to these three witnesses and see what their views are.

Senator BILL NELSON. Go ahead, gentlemen.
General Alexander?

General ALEXANDER. Sir, I—

Chairman WARNER. The MPs, what was their chain of command up and who had UCMJ authority over them?

Senator LEVIN. After November 19.

Chairman WARNER. After the 19th.

General ALEXANDER. Thank you. I've not studied the FRAGO, I've not seen it. I know of it, but that would specify in there who has UCMJ authority.

Chairman WARNER. Have we got it here? We're going to send it right down to you for a good judicial interpretation.

General ALEXANDER. All right, sir.

Senator LEVIN. You don't have the FRAGO, General?

Senator BILL NELSON. While we're waiting for that, I'll just ask General Alexander, when did you become aware of the abuses?

General ALEXANDER. Sir, I heard of the abuses when the initial reports came out in January that there were abuses going on. I did not understand at the time that there were MI personnel in charge because the way it was characterized was of an MP. So when I look at the abuses, I do not get normally the abuses of those outside MI.

As soon as we found out that there were MI involved, that's when they came to us and they said we need somebody, a senior officer that we could appoint who is senior to these level—

Senator BILL NELSON. When was that?

General ALEXANDER. Sir, that was on November 7 when they asked me for General Fay.

Senator BILL NELSON. November 7?

General ALEXANDER. No, sir, April 7, I'm sorry, sir.

Senator BILL NELSON. April 7.

General ALEXANDER. Yes, sir.

Senator BILL NELSON. When did you see the photographic evidence?

General ALEXANDER. Sir, on television.

Senator BILL NELSON. All right. When did you read the Taguba report?

General ALEXANDER. Sir, last week.

Senator BILL NELSON. What was the Army's plan for dealing with the strategic and operational consequences of the release of this evidence of prisoner abuse?

General ALEXANDER. Sir, I'm not sure I understand your question.

Senator BILL NELSON. If there was, it has been testified in front of this committee last Friday by the SECDEF, that he knew of abuses as far back as the middle of January, we've had other testimony to that effect. Now, what I want to know is, what was the Army's plan, knowing of abuses, that—what was your plan for dealing with the consequences of those abuses?

General ALEXANDER. Sir, there was a series of investigations, and when those came out, those series of problems—one of the things that the acting Secretary of the Army took upon him was, we have to look throughout the Army to see how our detainees are being operated, and he gave the—and I'll read you exactly, sir, here—he gave, for starting on February 11, the Department of the Army Inspector General, the mission to conduct a functional analysis of the Army's internment, enemy POW detention, interrogation policies, practices and procedures based on current DOD and Army policies and doctrine.

Senator BILL NELSON. Okay, I don't understand, I don't understand all that language.

General ALEXANDER. Yes, sir.

Senator BILL NELSON. The Army had to have a plan once they found out about abuses that if those abuses became public, there were going to be consequences in Iraq that were going to be inimical to our goal in Iraq, which is to stabilize Iraq.

So my question is, what were, are, the Army's plans for dealing with the consequences of abuses such as this being made public?

General ALEXANDER. Sir, the Army has not developed a plan as you say on going against—we are looking at all the things that we ought to do that as an Army in terms of what measures can we take with our allies, what are the things that we have to show as we are here today, what other venues should we do, what are the actions, is examples that folks like General Abizaid and others take in the leadership to show the Iraqi people that we are sorry and that we apologize for these, how do we police up our own ranks to ensure this will never happen.

All of that are things that the Army leadership and, I think it's important, the CJTF and the CENTCOM leadership are concurrently doing, because it's a combined—

Senator BILL NELSON. Okay, let me just wrap up here and then we can go back into this matter that you were talking about, Mr. Chairman. So you know of no plan, I call it a plan, but brainstorming session, if for that reason, of first finding out about these abuses and then saying, what in the world is this going to do to us out there in the Muslim world, specifically in Iraq, that is going to hinder the ultimate objective that we have, which is to stabilize Iraq? You know of no discussions or plan?

General ALEXANDER. No, absolutely, sir, in terms of brainstorming. At all levels we are brainstorming, we are looking at what are the things that we ought to do, what are—and I've been asked this, sir, last week by—in another committee, what could Congress do.

Senator BILL NELSON. Did anybody specifically discuss the kind of physical and torture violence and perhaps even beheading that would occur as a result of these abuses?

General ALEXANDER. No, sir. Nobody could come out and say, we think a civilian is going to be beheaded. I think we all are concerned that these events will increase the number of incidents, attacks against our soldiers and civilians throughout the region. We are clearly concerned about that, and that's one of the things that we as an Army, we as a military, and we as a Nation need to get out front, because those terrorist organizations that oppose us are going to use this as a rallying flag to go against that.

We all understand. We are all working on that, sir. From both the Joint Staff side, our side, we've had a working group amongst us with the Joint Staff to talk about, what are the things that we could or should do. So those are going on, sir.

Senator BILL NELSON. Mr. Chairman, I would just submit for our future discussion, and obviously General Alexander is not responsible here. But the question is that were we prepared about Muslim sensitivities in trying during an occupation to prepare that country for something they've never experienced in recent history called democracy, and so that had we been better prepared, that we would have immediately jumped on prison abuses and found out more about what they were.

Why don't you pursue the line on the difference on MI and MP?

Chairman WARNER. Yes, I will do that, but I think this hearing has really raised a lot of very important questions which the committee has to work to resolve, and I'm told by my staff that I may have inadvertently used the word ducking and bobbing, but that did not refer to this panel before us today, because I think you have been direct in your responses and pointed out, it's almost like a bowling alley. Everybody's been in his lane doing his job but somehow we need more cross action between these individuals.

So we come back to this order, FRAGO, and we now have the distinguished JAG interpreting. Judge?

General ROMIG. Yes, sir. The FRAGO, it would appear that since they are under TACON of the 205th, I'm talking about the 800th people, the MPs, that they have, the 205th has control for missions and tasking and things like that, but UCMJ remains with the 800th MP brigade.

Chairman WARNER. Remains with that. But now TACON then did go to the MI side?

General ROMIG. It did.

Chairman WARNER. It did.

General ROMIG. That's for control of movements and detailed direction of the operation of, it appears the facility.

Chairman WARNER. Then—

Senator BILL NELSON. Including the interpretation, I mean, the interrogation, if I might?

Chairman WARNER. That's my understanding, and that Taguba report, he took that position this morning.

General ROMIG. Sir, absent anything else, that's what it would appear to be.

Chairman WARNER. That's the way it reads to you. General Alexander, do you want to take a look at it?

General ALEXANDER. No, sir, I've looked at it, and that's why I said, I know that this is a key issue—

Chairman WARNER. But why don't you take a few moments and look at it?

General ALEXANDER. Sir, I've read it.

Chairman WARNER. Oh, you've read it.

General ALEXANDER. I have read it. It's my book that I passed over to him, and the key issue though is, what did General Sanchez convey to the two commanders and what did he expect of them, and my understanding from him is what we need to clarify to you, and that's one of the things that, as I started out, I said we'll take

that for the record so that we get it to you exactly correct, go through the Joint Staff to CENTCOM so that you know that we've done that, because I think that is one of the key issues of when he said that, who was expected to have responsibility for the MP part of security detainee operations?

It was pointed out, I think by General Taguba, if I'm not mistaken, that in fact General Karpinski thought that she still had that and it was 2 days after her initial investigation that she said, well, this order came out. So there is clearly disagreement, so this is one of the issues that has to be ironed out, and we owe that back to you accurately from—

Chairman WARNER. What does the plain English say?

General ALEXANDER. Just as General Romig read it, sir. TACON.

Chairman WARNER. The plain English language according to your interpretation is that TACON went from the MP commander to the MI commander.

General ALEXANDER. Yes, sir. It says under the first paragraph, effective immediately, the 205th Military Intelligence brigade commander assumes responsibility for the Baghdad central confinement facility and is appointed the FOB commander. Units directly at Abu Ghraib are under the TACON for security of detainees and FOB protection. Now—

Chairman WARNER. Embraced in there is the responsibility for the interrogation procedures?

General ALEXANDER. I think all of that is what needs to be laid out by General Sanchez so that we answer it exactly correct. But as I understand it, the 205th Military Intelligence Brigade remained responsible for the interrogation and the overall security of the facility itself, protecting all the persons there, both the detainees and the soldiers. That's what I think General Sanchez intended. I know how it reads, and we have to clarify that point.

Chairman WARNER. I come back again. So you feel that you need to do further research to determine whether or not this FRAGO in fact reposed in the MI the responsibility for the conduct of the interrogations?

General ALEXANDER. Sir, they always had—

Chairman WARNER. They always had that?

General ALEXANDER. They always had the conduct of the interrogations. I think the question, the key point, is did the MI brigade commander tell the MPs out in the general detention facility how to do their job? That was the key point.

Chairman WARNER. Which is a—to use a phrase—a preparatory step for the MI to come in, so in a sense—

General ALEXANDER. That's correct.

Chairman WARNER.—they were telling—I'm not suggesting what they did because we don't know, we're waiting for the reports. But someone is likely to have told the MPs, here are certain steps you can take, and I use the word soften up these prisoners, so when we come to the cell block, they're mentally and physically in such a condition that our interrogation can be more fruitful. Is that about right?

General ALEXANDER. That's how it's reported, sir, but it is my understanding—and that's why the November 19 and when these acts took place is such a key time, because if the ICRC report is

correct, as we believe it is, then it took place in October, or at least some of them.

Chairman WARNER. What took place?

General ALEXANDER. Some of these allegations by the ICRC of detainee abuse took place in October.

Chairman WARNER. Correct.

General ALEXANDER. Before the MI brigade was in charge.

Chairman WARNER. Correct. But they continued after the FRAGO is my understanding.

General ALEXANDER. Sir, that's what has to be clarified, because I don't know that we accurately know when they started, when they stopped, and what happened. Those dates, I don't have the dates of all the pictures. But I understand that they were late October, they were from early October, late October, early November, but I don't know how far that went on.

Chairman WARNER. To the extent that I have any knowledge, it's because of testimony perhaps the day before yesterday that this didn't stop until this very courageous enlisted man took the disk with photos on it and gave it to his superior, and at that point in time, then everybody turned to and realized we have a problem and it stopped. Has that scenario been related to any of you gentlemen?

General ALEXANDER. Not in those words, no, sir.

Chairman WARNER. Anything approximating?

General ALEXANDER. As I understand it, that at least we know it was going on through the October-November time period, so the detainee abuse cases or events, clearly October, November, and now the question is when did they stop. I think the key point of this November 19, so they're going on before the MI brigade takes command, did they change it and make it retroactive? No, they couldn't. So that could not have happened. We all agree on that.

So my concern is that we are trying to say that when we put the MI brigade commander in charge, what we did was already make the conditions to soften them up. Sir, look at what was going on in October and early November. It is clear that they had already had these infractions, and I don't know how long that went on. But clearly we have to find that out.

Chairman WARNER. I would go back, again we're trying to surmise in the October time frame, prior to the November 19 FRAGO, these actions of abuse were going on, but they were going on in the context of interrogations being conducted by MI people. Am I not correct in that?

General ALEXANDER. Those are the statements, and in each statement—

Chairman WARNER. There were MI people assigned to do those duties at that prison.

General ALEXANDER. Yes, sir. That's exactly right.

Chairman WARNER. Presumably they were trying to elicit intelligence from the prisoners.

General ALEXANDER. Those are named in General Taguba's report. There are three soldiers and two contractors named in his report. But as you state, there are indications that there are more and there are indications in places that say MI officers, and so what General Taguba recommended was that a Procedure 15 look

into that because he did not have the specific data to say it was that person who did it.

What they got was, they told me to do it, and that's where we really need to make sure we get the facts, wherever they may lead, sir, and bring them out and hold those who did wrong accountable.

Chairman WARNER. Good. Let me read you from the Taguba report, it's page 45, that Colonel Thomas Pappas, Commander of the 205th Military Intelligence Brigade be given a general officer memorandum of reprimand and investigated UP Procedure 15 AR activities for the following acts, which have been previously referred to in the aforementioned findings. So he was punished for the following: failure to ensure that soldiers under his direct command were properly trained in and followed the interrogation ROE. So he failed to ascertain that all of his soldiers had the proper training to adhere to the interrogation ROE, is that correct?

General ALEXANDER. That's correct, sir.

Chairman WARNER. That implies to me that MI people were not performing their duties, perhaps because they'd never been trained. Do you infer that from that language?

General ALEXANDER. Well, sir—

Chairman WARNER. Or improperly trained.

General ALEXANDER. I think, and as he listed out, and he lists out the four people, he, Colonel Jordan, and two others, who acted improperly, and any soldier, it says here, any soldier who does not report that is not following the interrogation ROE. We know that there were soldiers who were in some of those photographs who observed it and didn't report it.

Chairman WARNER. But if they—what this says, as I read it, ensure that soldiers in his command were properly trained, he didn't ensure that, so that training would have come under your jurisdiction, wouldn't it, for those soldiers?

General ALEXANDER. Sir, all the training for our soldiers under the interrogation ROE for the unit there would fall under the joint command that he's operating under. The doctrinal training that we have falls under the Army, and that's what we give them at Fort Huachuca. We also provide a mobile training team to bring them up.

Chairman WARNER. Okay. Much work has to be done, and I thank you all three of you—I have one or two questions left—for your cooperation and your direct response today, and I assure you that I have the highest respect for each of you and what you've tried to do.

But let me press on into this area. This goes to General Burgess. According to the CJTF-7 policies on interrogation ROE, there are certain interrogation techniques whose employment would require the explicit approval of the commanding general. The attachment to the Taguba Report included at least one memorandum requesting such approval from the commanding general, General Sanchez.

How frequently were requests made for approval to employ interrogation techniques requiring explicit approval?

General BURGESS. Sir, based on the knowledge that I have, there were no requests to General Sanchez.

Chairman WARNER. Therefore, the next question you've answered, how often were such requests approved by Sanchez? There were none.

Now, accountability. That's a subject that's very much on the minds of us here in Congress. I'll ask this to the JAG. Court-martial action against certain individuals has been, that's past tense, recommended, but only administrative action against leaders in the chain of command such as Brigadier General Karpinski and Colonel Pappas, Lieutenant Colonel Jordan, Lieutenant Colonel Phillabaum, and others. The apparent failures of leadership of these individuals as documented in the Taguba Report could suggest more stringent responses than "a memorandum of reprimand" essentially letters of admonishment.

In your view, are the disciplinary actions recommended for members of the chain of command appropriate for the offenses in this situation?

General ROMIG. Mr. Chairman, first I would point out that it was the commander on the scene who assessed the evidence before them in the context of what was going on there and made those decisions. It's certainly within the realm of the reasonable and that's why in our system you have the ability of a commander to choose a couple different options or more.

I would say that some of these, you mentioned Colonel Pappas, that is still pending the Procedure 15, and there may be some other things that could come out of this as the cases move forward and more investigation is done. So I'm not sure it's over as it stands right now.

Chairman WARNER. That's the next question. Do the administrative and non-judicial actions taken to date preclude reexamination of any of these cases and potential judicial action under the UCMJ?

General ROMIG. No, sir.

Chairman WARNER. So that avenue is still open?

General ROMIG. Yes, sir.

Chairman WARNER. Gentlemen, I think we had a marathon, close to 7 hours of hearing, but we thank you very much first for your distinguished careers of service, for your continuing effort to assist the SECDEF and the Acting Secretary of the Army and all others to get to the bottom of it, including the United States Senate and the Congress of the United States. So thank you very much.

I will be in consultation with the ranking member, Mr. Levin, with regard to future hearings of this committee. It's apparent to me that we need to do a good deal more work and there are a lot more witnesses to work with. But we're faced with the fact that our bill is on the floor beginning Monday, and it's at the moment not clear to me that we can next week continue with a hearing in view of the heavy commitment of all members of this committee to floor action. Then following that's a recess period, so we could be 2 weeks away, although I'll examine Thursday of this week with the staff and Senator Levin and see whether or not the availability of some of the witnesses we have in mind can be arranged for that hearing.

So for the moment, subject to further announcement, we'll let you know of our schedule. But thank you again for today. The hearing is adjourned.

[Questions for the record with answers supplied follow:]

QUESTIONS SUBMITTED BY SENATOR JOHN MCCAIN

GITMO-IZING ABU GHRAIB

1. Senator MCCAIN. General Alexander, General Burgess, and General Romig, it has been reported that General Miller wanted to GITMO-ize the confinement operations at Abu Ghraib prison because of your concern in that facility that military intelligence was not getting the information from detainees like he thought they should be. What did he mean by GITMO-izing Abu Ghraib prison?

General ALEXANDER. I am unaware of any such statement being made by Major General Miller.

General BURGESS. I am unaware of any such statement being made by Major General Miller. During General Miller's testimony in the Senate hearing on Iraq prison abuse on 19 May 2004, Senator Daniel Akaka (D) Hawaii asked him: "Did you tell General Karpinski that you were going to GITMO-ize Abu Ghraib? My question is, what did you mean by this statement?"

General Miller responded: "Senator, I did not tell General Karpinski I would GITMO-ize Abu Ghraib. I don't believe I've ever used that term. Ever."

General ROMIG. I am unaware of any such statement being made by Major General Miller.

GENERAL OFFICER APPROVAL OF INTERROGATION TACTICS

2. Senator MCCAIN. General Alexander, General Burgess, and General Romig, General Miller announced that certain practices would be discontinued, including hooding, stress positioning, and sleep deprivation, but that they would be permitted with approval by a general officer. Under what authority can a general officer permit these techniques?

General ALEXANDER. Concur with Major General Romig and Major General Burgess.

General BURGESS. A general officer can only approve techniques that are approved by doctrine and in accordance with applicable international law. In addition, the Secretary of Defense may further limit authority by requiring that he receive specific notification and/or provide approval of certain lawful techniques.

General ROMIG. If a practice or technique is lawful, a commander may restrict the use of that practice or technique in many ways, including that a general officer approve its use. To the extent that any practice involving detainees violates U.S. or international law, no general officer would have authority to permit the practice or technique.

CAUSE OF DEATH OF FORMER HEAD OF IRAQ'S AIR FORCE

3. Senator MCCAIN. General Alexander, General Burgess, and General Romig, the Denver Post reports an allegation that the former head of the Iraqi Air Force died during interrogation when he was rolled up inside a sleeping bag so only his feet stuck out, and then sat on and rolled back and forth until he died of suffocation. Apparently the investigation concluded that this was a death from "natural causes." What can you tell me about this?

General ALEXANDER. I have been informed that the case is presently being investigated by the Army's Criminal Investigation Command as a suspected homicide.

General BURGESS. Army Criminal Investigation Division (CID) initiated an investigation immediately after the death of Major General Mowhosh, the former Iraqi Air Defense Minister, on November 26, 2003. A preliminary investigation determined that General Mowhosh died during interrogation by two U.S. Army interrogators. The CID investigation is ongoing and being treated as a suspected homicide.

General ROMIG. I have been informed that the case is presently being investigated by the Army's CID as a suspected homicide.

PRISON GUARDS

4. Senator MCCAIN. General Alexander, General Burgess, and General Romig, is it now, or has it been, administration policy that prison guards should "facilitate" detainee interrogations? If so, how were they instructed to do this?

General ALEXANDER. I don't know of any administration policy that prison guards should facilitate detainee interrogations. However, it is clear that in screening pris-

oners and understanding the state-of-mind of detainees to be interrogated, MI and MP should work together. Specifically, FM 34-52 says on page 3-9, "Interrogators should question guards about the sources, time permitting, as part of preparation. Since the guards are in constant contact with the sources, they may be able to provide information on:

- Their physical condition.
- Demonstrated attitude and behavior.
- Contact made with other guards or sources.
- How the source has been handled since capture.
- Hearsay (H/S) information from others who have handled the source.
- Confirmation of capture data, especially the circumstances under which the sources was captured."

General BURGESS. I am not aware of any policy that prison guards should facilitate detainee interrogations.

General ROMIG. I don't know of any administration policy that prison guards should facilitate detainee interrogations. I am aware that this issue was reviewed by both Major General Miller, Commander of JTF-GITMO, and Major General Ryder, Army Provost Marshal General, last fall, and more recently by Major General Taguba, CFLCC Deputy Commanding General, in his investigation of the 800th Military Police Brigade. Neither Army doctrine on detention operations (Army Regulation 190-8, Enemy Prisoners of War, Retained Personnel, Civilian Internees and Other Detainees) nor the Army's Field Manual 34-52, Intelligence Interrogation, addresses the issue other than to specifically prohibit physical or moral coercion and inhumane treatment to compel information. In my opinion, we need to revise our doctrine to better define the relationship between interrogators and those responsible for operating detention facilities.

PERMISSIVE CLIMATE OF PRISONER ABUSE

5. Senator MCCAIN. General Alexander, General Burgess, and General Romig, in Secretary Rumsfeld's May 7, 2004 testimony, he testified that the Abu Ghraib prison personnel followed the provisions of the Geneva Conventions and that the Geneva Conventions were posted for all prison personnel to see. General Taguba has stated that neither the camp rules nor the provisions of the Geneva Conventions were posted in English or in the language of the detainees at any of the detention facilities in the 800th Military Police (MP) Brigade's area of responsibility. Would this supervisory error not contribute to a permissive climate of prisoner abuse?

General ALEXANDER. Posting of camp rules and the applicable Geneva Conventions is required by the conventions and service regulations. However, the absence of these postings cannot be directly related to a permissive climate of prisoner abuse.

General BURGESS. At this time ongoing investigations will determine where and how the camp rules and Geneva Conventions provisions were posted in the 800th MP Brigade's area during the time the alleged offenses took place.

General ROMIG. Posting of camp rules and the applicable Geneva Conventions is required by the conventions and service regulations. Failure to adhere to this requirement could be one of a number of indicators that regulations were not strictly followed. Without more facts, however, I cannot conclude that a failure to post the documents would necessarily contribute to a permissive climate of prisoner abuse.

PROSECUTION OF CIVILIAN OPERATORS IN ABU GHRAIB

6. Senator MCCAIN. General Alexander, General Burgess, and General Romig, interrogation specialists from private defense contractors were operating inside Abu Ghraib and may have taken part in these atrocities. Given the Uniform Code of Military Justice (UCMJ) has been amended by the Military and Extraterritorial Jurisdiction Act of 1999, do you intend to prosecute the contractors who allegedly abused prisoners and committed other atrocities under the UCMJ?

General ALEXANDER. Concur with Major General Romig.

General BURGESS. As standard practice, military commanders order investigations when personnel under their command are suspected of committing UCMJ offenses, including atrocities of this nature. The Department of Justice has the authority to prosecute contractor employees of the Department of Defense under the Military Extraterritorial Jurisdiction Act (MEJA). Contractors are only subject to the UCMJ during a declared state of war. I would respectfully defer all legal opinions to General Romig.

General ROMIG. The MEJA of 2000 is a separate and distinct Federal criminal statute. It does not amend the UCMJ, nor does it enforce the punitive articles of the UCMJ. Under MEJA, the decision to prosecute is made by the Department of Justice (DOJ). It is my understanding that DOJ is currently reviewing the conduct of certain private defense contractors in Iraq.

QUESTIONS SUBMITTED BY SENATOR CARL LEVIN

CHAIN OF COMMAND AT ABU GHRAIB

7. Senator LEVIN. General Alexander, we have heard that Abu Ghraib Prison was placed under the command of the 205th Military Intelligence Brigade commander on November 19, 2003. According to General Taguba, this effectively made an MI Officer, rather than a Military Police (MP) Officer, responsible for the MP units conducting detainee operations at that facility, which is not doctrinally sound due to the different missions and agendas assigned to each of these respective specialties. Who made the decision to put the MI commander in charge of the Abu Ghraib facility and why?

General ALEXANDER. According to Lieutenant General Sanchez's testimony before Congress, he put the 205th as TACON authority on November 19 to enhance the force protection posture of Abu Ghraib, i.e., to act as the garrison commander of FOB Abu Ghraib, not to assume the responsibilities for detention operations

8. Senator LEVIN. General Alexander, does the Department agree with General Taguba's conclusion that this decision was "not doctrinally sound"?

General ALEXANDER. It normally would not be "doctrinally sound" to place a Military Intelligence (MI) commander in charge of the Military Police in order to run a prison as MI personnel are not trained in the running of a prison; however, as stated before, Lieutenant General Sanchez testified it was never his intent for MI to run the prison, but to assume responsibility for the force protection of the base.

9. Senator LEVIN. General Alexander, General Taguba specifically recommended that General Karpinski, brigade commander, be relieved from command and issued a General Officer Memorandum of Reprimand. General Karpinski was issued a General Officer Memorandum of Admonishment on January 17, 2003 but as of early March was still in command of the 800th Military Police Brigade. On what basis was General Karpinski issued a General Officer Memorandum of Admonishment on January 17?

General ALEXANDER. General Karpinski was issued a General Officer Memorandum of Admonishment on January 17 by Lieutenant General Sanchez because incidents that had occurred "reflect a lack of clear standards, proficiency and leadership within the brigade."

10. Senator LEVIN. General Alexander, why was General Karpinski not relieved of command at that time?

General ALEXANDER. As this is a command decision, refer to CJTF-7, Lieutenant General Sanchez.

11. Senator LEVIN. General Alexander, it has been reported that General Miller's review team recommended that military police set the conditions for the successful interrogation and exploitation of internees/detainees and that the guard force be actively engaged in setting the conditions for successful exploitation of the internees. General Taguba has stated that these recommendations would appear to be in conflict with the recommendations of General Ryder's Team and AR 190-8 that military police do not participate in military intelligence supervised interrogation sessions. Do you agree with General Taguba's conclusion that military police should not be asked to "set the conditions" for interrogations?

General ALEXANDER. Military Police are part of the interrogation mission. Their role is not only to secure the detainees as well as escort them to and from interrogation booths but also to provide passive intelligence to interrogators. Per Field Manual 34-52, "interrogators should question guards about the sources, time permitting, as part of preparation. Since the guards are in constant contact with the sources, they may be able to provide information on: their physical condition; demonstrated attitude and behavior; contact made with other guards or sources. . ." MPs are in a unique position to provide information on detainees because of their daily interaction with them. Army G2 believes Military Police should not play an active role during actual interrogations, meaning except for security presence, they should not

interact with detainees during interrogations nor conduct their own “interrogations” of detainees. Military doctrine and policy has to be updated to reflect the roles and responsibilities of both MPs and MI for future detention operations.

12. Senator LEVIN. General Alexander, doesn't the subsequent decision to appoint General Miller to take over Abu Ghraib prison appear to ratify his recommendation for using military police to support interrogations? Doesn't this send the wrong message after the abuses at Abu Ghraib?

General ALEXANDER. See answer to question #11.

13. Senator LEVIN. General Alexander, who made the decision to appoint General Miller?

General ALEXANDER. Refer to CJTF-7, Lieutenant General Sanchez, for answer.

ROLE OF THE JUDGE ADVOCATE GENERALS

14. Senator LEVIN. General Romig, the Army Judge Advocate General (JAG) Corps has consistently served as one of our strongest lines of defense against unlawful or indefensible conduct by members of the military. That line of defense appears to have broken down at Abu Ghraib prison. To your knowledge, was there a JAG assigned to Abu Ghraib prison—with either the military police battalion or the military intelligence brigade responsible for the prison? If so, was the JAG consulted on the detention and interrogation techniques used by military police and military intelligence at the prison?

General ROMIG. The 800th Military Police Brigade had a Lieutenant Colonel Staff Judge Advocate with an organic legal element that provided area coverage to the Abu Ghraib detention facility. The 205th Military Intelligence Brigade had two Brigade Judge Advocates, one of whom was assigned to the Abu Ghraib detention facility with his brigade in late November. A magistrate's cell, typically consisting of three Judge Advocates, was placed at Abu Ghraib in late September 2003 in order to conduct legal reviews of detention. The 205th Military Intelligence Brigade Judge Advocate was consulted on interrogation approaches as necessary. Additional legal support was provided by the CJTF-7 SJA section.

15. Senator LEVIN. General Romig, did the JAG review interrogation plans on a case-by-case basis to ensure their compliance with Army regulations and the Geneva Conventions?

General ROMIG. The Brigade Judge Advocate would review interrogation plans and observe interrogations on a periodic basis. He did not review all plans or attend all interrogations. The Judge Advocate reviewed all requests for exception to CJTF-7s 12 October 2003 Interrogation Policy. The CJTF-7 Staff Judge Advocate reviewed requests for exception that were submitted to the CJTF-7 Commander.

16. Senator LEVIN. General Romig, who has responsibility for ensuring that the Interrogation Rules of Engagement (IROE) in Iraq, provided to this committee at today's hearing, are properly applied and adhere to the Geneva Accords?

General ROMIG. This is a command responsibility. Under Army doctrine as reflected in FM 34-52, Intelligence Interrogation, the command's J2, G2, or S2 has primary staff responsibility to ensure interrogation activities are performed in accordance with the Geneva Conventions and U.S. policies. The manual further states that if there is any doubt as to the legality of a proposed form of interrogation, the advice of the Command Judge Advocate should be sought before using the method in question. The IROE document provided to the committee was locally-produced by the officer in charge of interrogations at the Abu Ghraib Prison and informally reviewed by the 205th Military Intelligence Brigade Judge Advocate along with members of the Office of the Staff Judge Advocate, CJTF-7. [I would also like to point out that the term “IROE” is an improper use of the concept of ROE. In military operations, the term “rules of engagement (ROE)” refers to limitations on the use of force.]

17. Senator LEVIN. General Romig, what role does your office play in vetting and approving rules for the conduct of interrogations?

General ROMIG. We provide legal advice to the Army Chief of Staff and the Army Staff on a wide range of matters, including the DOD Law of War Program and the DOD Program for Enemy Prisoners of War and Other Detainees. This includes reviewing Army interrogation doctrine for legal sufficiency. In the case of interrogations at Guantanamo, we participated in a review of interrogation procedures as

part of a DOD Working Group (please see my answer to question 28). In Iraq, my office does not have a direct role in vetting and approving rules for the conduct of interrogations. The collection of intelligence is tasked to components assigned to the Subordinate Joint Force Command (CJTF-7) in accordance with collection plans prepared by the Command's J2. The chain of command runs from CJTF-7 through the Combatant Command (USCENTCOM) to the Joint Staff. Legal officers are assigned to each of these headquarters. Although my office is not technically in the chain of command, we are a "reach-back" source from which judge advocates in the field can request advice or opinions regarding any legal issue affecting current operations. I am not aware of this happening for this particular issue.

18. Senator LEVIN. General Romig, did your office review these IROEs?
General ROMIG. No.

ACCOUNTABILITY OF CIVILIAN CONTRACTORS

19. Senator LEVIN. General Romig, there is evidence that civilian contractors may have been involved in some of the potentially criminal actions documented in the Taguba Report. It has been reported that a contractor serving as an interrogator at Abu Ghraib allowed and/or instructed MPs, who were not trained in interrogation techniques, to facilitate interrogations by "setting conditions" which were neither authorized and in accordance with applicable regulations/policy and he clearly knew his instructions equated to physical abuse. If you conclude that civilian contractors overseas have committed criminal acts, what systems are in place to hold them accountable and is there a court with jurisdiction to try them for criminal conduct?

General ROMIG. U.S. contractors accompanying a force are not subject to the UCMJ except in time of a congressionally declared war. However, they are still subject to U.S. Federal jurisdiction under the War Crimes Act (which provides for jurisdiction over any U.S. national who commits a "war crime"), 18 USC §§ 2340-2340A (implementing the Torture Convention), and potentially to the Military Extraterritorial Jurisdiction Act.

20. Senator LEVIN. General Romig, has anybody in the Department reviewed the use of civilian contractors as interrogators to determine whether this is an appropriate use of contractors or is an inherently governmental function?

General ROMIG. I believe the Army is reviewing the issue.

QUESTIONS SUBMITTED BY SENATOR EDWARD M. KENNEDY

PROCESS IN FORMULATION OF DETENTION AND INTERROGATION RULES OF ENGAGEMENT

21. Senator KENNEDY. General Romig, I provided you with two media reports (the UPI article by Arnaud de Borchgrave and the Salon.com article by Joe Conason, both dated May 11, 2004). Were you previously aware that senior Judge Advocate General (JAG) officers went outside the Department to the New York City Bar Association to raise their concerns on the formulation of military interrogation and detention rules?

General ROMIG. No.

22. Senator KENNEDY. General Romig, the JAG officers reportedly said that civilian appointees, and particularly Mr. Feith and Mr. Haynes, have ignored or bypassed the military lawyers with respect to the formulation, drafting, vetting, and implementation of interrogation rules of engagement and other legal issues related to the subjects of our hearings. Please describe the process for establishing policies on interrogation rules of engagement and detention and the role of JAG officers in the process.

General ROMIG. Army doctrine and policies for intelligence interrogation are contained in Field Manual 34-52, Intelligence Interrogation. The most current version is dated 28 September 1992. The FM implements general principles contained in Field Manual 34-1, Intelligence and Electronic Warfare Operations, and several standardization agreements (STANAGs) that the U.S. has entered into with our NATO allies (i.e., STANAG 2033, Interrogation of Prisoners of War; STANAG 2044, Procedures for Dealing with Prisoners of War; and STANAG 2084, Handling and Reporting of Captured Enemy Equipment and Documents). The principles and techniques of interrogation set out in the FM specifically incorporate the constraints established by the UCMJ and the 1949 Geneva Conventions. The FM recognizes that intelligence interrogation execution will vary depending on unit mission, task orga-

nization, and collection priorities. The current manual was reviewed for legal sufficiency and comment by Judge Advocates assigned to U.S. Army Intelligence Center (the agency proponent) and in the Office of The Judge Advocate General (OTJAG). All changes recommended by OTJAG were incorporated in the final FM. Regarding the role of Judge Advocates assigned to commands in the field, please see my answer to questions 16 and 17.

23. Senator KENNEDY. General Romig, have the processes changed since September 11, 2001? If so, please describe the previous process, highlighting the differences between then and now.

General ROMIG. Please see my answer to question 28.

24. Senator KENNEDY. General Romig, since the assumption by Mr. Feith and Mr. Haynes of their current positions, what has been their role in the matters and processes described in the previous question?

General ROMIG. Aside from the formulation of a working group noted in question 28, I am not aware of any role Mr. Haynes may have played in the processes described in the previous question. With regard to Mr. Feith, on January 17, 2002, he issued a memorandum, subject: Responsibility for detainees in association with the global war on terrorism, in which he advised that the Assistant Secretary of Defense (Special Operations and Low-Intensity Conflict) would assume responsibility for "overall development, coordination, approval, and promulgation of major DOD policies and plans related to persons detainees in association with the global war on terrorism. This include[d] development, coordination, approval, and promulgation of major DOD policies, and new courses of action with DOD components and other Federal agencies as necessary." This memorandum also advised that DOD Directive 2310.1 would be adjusted to reflect this decision. I have no knowledge of what other role, if any, Mr. Feith has had in these matters.

25. Senator KENNEDY. General Romig, after assuming their positions, did either Mr. Feith or Mr. Haynes alter the role of civilian appointees in the process? If so, was this done by formal order, by oral directions, or some other means? Please provide any documentation that would indicate when this change was made and the substance of those changes.

General ROMIG. Please see my answer to question 24.

26. Senator KENNEDY. General Romig, if the decisions on IROE and other legal issues were not made and implemented through the regular pre-existing assignments, channels, and command chain, including JAG, how were they made and communicated to the action commands and officers? Please provide details on the rules and other orders most relevant to these hearings and list the others affected.

General ROMIG. Please see my answer to question 16. I am not aware of any other decisions involving legal matters that were made outside regular pre-existing assignments, channels, and command chain.

27. Senator KENNEDY. General Romig, if such decisions were communicated by Mr. Feith and/or Mr. Haynes horizontally or upwards to other civilian officials, and then downward to military officials, please describe those channels in as much detail as you can, providing documentation where available.

General ROMIG. I have no personal information on how Mr. Feith or Mr. Haynes communicates decisions aside from established channels and modes, such as information papers, directives, instructions, and policy guidance.

MR. HAYNES' "WORKING GROUP"

28. Senator KENNEDY. General Romig, are you familiar with the "working group" under the direction or other leadership of Mr. Haynes, described to us by another witness, in connection with the matters under review by the committee? Please describe the membership and functions of that working group. If you or any member of your office were a member, please provide all documentation with respect to that group. If no one in your office was a member, please explain why, when, and how that occurred.

General ROMIG. In early January 2003, a working group of various attorneys and operators was formed within the Department of Defense regarding detainee interrogation. The group was generally directed to review interrogation procedures at Guantanamo, and make recommendations regarding appropriate techniques and approaches. The specific function, membership, reports, and comments of the working

group are contained in classified documents maintained by the Department of Defense. The group was headed up by Mary Walker, Air Force General Counsel, who reported the findings of the group to Mr. Haynes. Members of my staff served on the working group. In March, I submitted a memorandum to Ms. Walker expressing a number of reservations and concerns with the final draft of the working group report. In addition, we briefed the Army Chief of Staff and Deputy Chief of Staff, G-3, of our concerns in preparation for Joint Staff meetings on this issue.

NEWS ARTICLES AND THE TAGUBA REPORT

29. Senator KENNEDY. General Romig, do you believe that the concerns reportedly raised by JAG officers in the above mentioned articles may have been a contributing cause of any of the gaps, faults, and misbehavior described in the Taguba Report? Please explain in detail.

General ROMIG. Please see my answer to question 30.

INTERROGATION SAFEGUARDS AND JAG'S INVOLVEMENT

30. Senator KENNEDY. General Romig, the civilian officials reportedly removed safeguards designed to prevent the abuse of prisoners. One of those safeguards was the routine observation from behind a two-way mirror by a JAG officer who was empowered to stop any misconduct. The instructions originated by these officials also reportedly granted private contractors unprecedented participation in the interrogation process—precisely because such civilian contractors are not covered by the UCMJ and therefore are “free to do whatever they want to do.” An April 26, 2002, report in the Wall Street Journal stated that the JAG Corps “keeps a lawyer on hand during interrogations, for quick decisions on the degree of physical or mental pressure allowed.” Was this military policy? If so, under what circumstances? Is this no longer policy? If so, when was this change in policy made, who made it, how was it transmitted to the field, and did the JAG Corps have any role in making this policy change?

General ROMIG. I believe the individuals who reported that officials removed safeguards designed to prevent abuse of prisoners, specifically that these officials prevented judge advocates from being present during all interrogations, are incorrect in their understanding of the facts. To the best of my knowledge, judge advocates have never routinely observed all intelligence interrogations. During Operations Desert Shield/Desert Storm, judge advocates at the division, corps, and theater level were available to advise commanders on a wide-range of operational law issues, including the application of the law of war and the UCMJ as to interrogations and treatment of detainees. Judge advocates were neither required to nor precluded from observing interrogations. As a practical matter, it would have been physically impossible for judge advocates to routinely observe all of the large number of interrogations that occurred during those operations. After discussing the issue with command legal advisors, it is my understanding that the current practices at Guantanamo and in Iraq are the same: judge advocates are neither required to nor precluded from observing interrogations.

31. Senator KENNEDY. General Romig, have JAG lawyers been present during all interrogations conducted by military or intelligence personnel in Iraq, Afghanistan, and Guantanamo Bay? If not, do you believe that the absence of JAG lawyers may have contributed to any of the reported abuses in Iraq, Afghanistan, and Guantanamo Bay?

General ROMIG. Please see my answer to question 30.

32. Senator KENNEDY. General Romig, according to the Taguba Report, a new policy authorizing the use of “stress and duress” practices was initiated by the Pentagon in late 2002 or early 2003. Are you aware of this change in policy? Who made it and when, how was it transmitted to the field, and did the JAG Corps have a role in making this policy change?

General ROMIG. I am not aware of any change of policy other than noted in my answer to question 28.

33. Senator KENNEDY. General Romig, do you believe that this change in policy contributed to any of the reported abuses in Iraq or Afghanistan?

General ROMIG. Please see my answer to question 32.

34. Senator KENNEDY. General Romig, was the JAG Corps involved in the decision to give private contractors much broader authority to interrogate military detainees?

General ROMIG. My office was not involved in the decision to employ private contractor interrogators or how much authority private contractors should have when interrogating military detainees.

35. Senator KENNEDY. General Romig, who made this decision and when and how was it transmitted to the field?

General ROMIG. I don't know.

36. Senator KENNEDY. General Romig, in making this policy change, did policy-makers discuss the lack of accountability under the UCMJ for civilian contractors?

General ROMIG. I don't know.

37. Senator KENNEDY. General Romig, was there any discussion of the limits of jurisdiction for prosecuting military contractors?

General ROMIG. There has been considerable discussion within all the Services regarding the increasing reliance of contractors on the battlefield, the lack of UCMJ jurisdiction except during periods of a congressionally declared war, and the other possible forums for exercising criminal jurisdiction (the War Crimes Act, 18 USC §§ 2340–2340A, and potentially the Military Extraterritorial Jurisdiction Act). However, I am not aware of discussions focused on contractors hired to perform interrogations.

38. Senator KENNEDY. General Romig, do you share the concerns reportedly expressed by the JAG articles as summarized in the three articles I have referenced?

General ROMIG. As set out in my answer to question 30, I believe the concerns reportedly raised by Judge Advocates in the articles were based upon an incorrect understanding of JAG roles in observing interrogations, both during Operation Desert Storm and in our present conflicts. To that extent, I do not share their concerns. As to any concerns I may have had regarding the formulation of interrogation policies at Guantanamo, please see my answer to question 28.

[Whereupon, at 5:57 p.m., the committee adjourned.]

ALLEGATIONS OF MISTREATMENT OF IRAQI PRISONERS

WEDNESDAY, MAY 19, 2004

U.S. SENATE,
COMMITTEE ON ARMED SERVICES,
Washington, DC.

The committee met, pursuant to notice, at 8:35 a.m. in room SH-216, Hart Senate Office Building, Senator John Warner (chairman) presiding.

Committee members present: Senators Warner, McCain, Inhofe, Roberts, Allard, Sessions, Collins, Ensign, Talent, Chambliss, Graham, Dole, Cornyn, Levin, Kennedy, Byrd, Lieberman, Reed, Akaka, Bill Nelson, E. Benjamin Nelson, Dayton, Bayh, Clinton, and Pryor.

Committee staff members present: Judith A. Ansley, staff director; and Leah C. Brewer, nominations and hearings clerk.

Majority staff members present: Charles W. Alsup, professional staff member; William C. Greenwalt, professional staff member; Gregory T. Kiley, professional staff member; Elaine A. McCusker, professional staff member; Lucian L. Niemeyer, professional staff member; Paula J. Philbin, professional staff member; Lynn F. Rusten, professional staff member; Scott W. Stucky, general counsel; Diana G. Tabler, professional staff member; and Richard F. Walsh, counsel.

Minority staff members present: Richard D. DeBobes, Democratic staff director; Daniel J. Cox, Jr., professional staff member; Jeremy L. Hekhuis, professional staff member; and William G.P. Monahan, minority counsel.

Staff assistants present: Michael N. Berger, Andrew W. Florell, and Bridget E. Ward.

Committee members' assistants present: Christopher J. Paul, assistant to Senator McCain; John A. Bonsell, assistant to Senator Inhofe; Darren M. Dick, assistant to Senator Roberts; Arch Galloway II, assistant to Senator Sessions; Derek J. Maurer, assistant to Senator Collins; D'Arcy Grisler, assistant to Senator Ensign; Clyde A. Taylor IV, assistant to Senator Chambliss; Aleix Jarvis and Meredith Moseley, assistants to Senator Graham; Christine O. Hill, assistant to Senator Dole; Russell J. Thomasson, assistant to Senator Cornyn; Sharon L. Waxman and Mieke Y. Eoyang, assistants to Senator Kennedy; Frederick M. Downey, assistant to Senator Lieberman; Elizabeth King, assistant to Senator Reed; Davelyn Noelani Kalipi and Richard Kessler, assistant to Senator Akaka; William K. Sutey, assistant to Senator Bill Nelson; Eric Pierce, assistant to Senator Ben Nelson; Rashid Hallaway, assist-

ant to Senator Bayh; Andrew Shapiro, assistant to Senator Clinton; and Terri Glaze, assistant to Senator Pryor.

**OPENING STATEMENT OF SENATOR JOHN WARNER,
CHAIRMAN**

Chairman WARNER. Good morning, everyone. The committee meets today for the third in a series of hearings regarding the mistreatment of Iraqi prisoners by a small—hopefully, a very small—number of personnel of the Armed Forces of the United States, in violation of U.S. and international laws.

Testifying before us today are General John P. Abizaid, Commander, U.S. Central Command (CENTCOM); Lieutenant General Ricardo Sanchez, Commander, Multi-National Force-Iraq; Major General Geoffrey Miller, Deputy Commander for Detainee Operations, Multi-National Force; and they are joined this morning by their Judge Advocate General (JAG), which I think is a very wise decision.

We welcome our witnesses and thank them again for their service. Many times members of this committee and other Members of Congress have gone abroad and visited each of you in CENTCOM, and, most particularly, in Afghanistan and Iraq. We must all be mindful of the role of our witnesses in the operational chain of command and of their related responsibilities in the administration of military justice. Each witness this morning will use caution with regard to their comments, such as not to inadvertently influence, in any way, the ongoing criminal or administrative proceedings and the investigations. Many investigations instituted by the Department of Defense (DOD) are now ongoing. Indeed, this morning we see the opening of the first trials, an opening in a manner in which the entire world can see democracy in action.

As I have previously stated, this mistreatment of prisoners represents an appalling and totally unacceptable breach of military regulations and conduct. Our committee, a part of the United States Congress, a coequal branch of government, has a solemn responsibility to determine, as best we can, how this breakdown in military leadership and discipline occurred, and, most importantly, what steps are being taken, by the civilians in control and, indeed, those in the uniform, to see that it never, ever happens gain.

I firmly believe this prisoner mistreatment represents an extremely rare chapter in the otherwise proud, magnificent history of the United States military. It is counter to every human value that we, as Americans, have learned beginning in our earliest stage with our families, our schools, and our churches. It is counter to what this Nation stands for, and it is counter to the principles that the men and women of the Armed Forces, today and in years past, have fought to protect wherever they are in the world. It is counter to the cause of freedom.

There must be a full accountability for the abuse of Iraqi detainees, and important questions must be asked of the chain of command to understand what happened, how it happened, when it happened, and how those in positions of responsibility either ordered, encouraged, authorized, or maybe looked the other way at such conduct.

Our witnesses today are uniquely qualified to answer many of these important questions, including:

What policies and procedures were established for the treatment of prisoners and detainee interrogations?

What was the chain of command at the prison?

Were military police (MPs) or military intelligence (MI) personnel in charge, and at what times?

When did you—I say that collectively and individually—realize the magnitude, seriousness, and uniqueness of these allegations?

What measures did you take to inform the civilian structure, from the President to the DOD, Department of State, and others, that civilian structure that has the ultimate responsibility for the control of the United States military, which goes back to the very origins of this country?

What steps were taken to respond to earlier reports of mistreatment of prisoners received from the International Committee of the Red Cross (ICRC) and possibly other sources?

Finally, how did the conduct of interrogations and detainee operations evolve from May 2003 until January 2004?

I am confident that you will, to the best of your ability, be responsive to these and other questions.

I am proud of the manner in which the Armed Forces of the United States, represented by these extraordinarily accomplished officers before us, have promptly reacted to the allegations, undertaken the appropriate investigation, and begun disciplinary actions under the Uniform Code of Military Justice (UCMJ). The trials, in some instances, begin today.

We are a nation of laws. We confront breaches of our laws openly and directly, and we must find the evidence to hold those who break the law accountable. We must not forget our overall purpose in Iraq and, indeed, in Afghanistan. Success in both areas is essential not only to our Nation and the people of Iraq, but to the entire world as we fight global terrorism.

We all have an important stake in learning the truth. We must not allow these acts of a few to tarnish the honor of the many dedicated men and women in uniform, 99.99 percent of whom are valiantly upholding the values they were taught in the cause of freedom, and doing so at great personal risk and with great sacrifice.

Lastly, how this hearing originated is spelled out in a letter that I wrote to the Secretary of Defense (SECDEF) last week on May 13, in which I thanked him for his participation and assistance in facilitating the hearings that we had had. I indicated that our committee would pursue further hearings and involve a list of witnesses, and I named them all, you three among them.

Then I will recite this paragraph: "To date, in scheduling, the committee has tried to meet your requirements, and we hope to continue such cooperation in arranging the earliest possible date for appearances of these witnesses. Given that some witnesses may need to remain in Iraq for operational reasons, we are open to exploring the option of video teleconferences for some hearings."

In the course of the last few days, in working with the Department on having, I thought, several civilians come up today, somewhat unexpectedly my distinguished colleague, Senator Levin, and I were informed that you were in town, General Abizaid, and had

been for several days, and that the other witnesses were coming for consultation to the DOD. Therefore, the Secretary made you available here this morning. That is, plain and simple, how it happened.

As to the conduct of this hearing, the buck stops right here on this desk, and I am the chairman, and I consult with my members, as my distinguished ranking member consults with his, and I am very proud in the manner in which this committee has pursued its responsibilities under the Constitution. We are trying to search for the facts and put together a record so that we here in Congress, and, indeed, the American public can better understand these problems.

This story has been unfolding in many ways. First, a very brave enlisted man sought to bring to the attention of his superiors a problem which, frankly, in his gut he knew was wrong. He is to be commended for that. Thereafter, the military very quickly took action, and the rest is history. The press has been diligent. The victims have actually gone on to tell their story. The lawyers are trying to interpret it. Really, the distressing thing is watching the families of the soldiers who are under the UCMJ now being examined, as well as the families of other soldiers. I felt it was imperative that, at some point in time—and the Pentagon basically selected when that time would be: this morning—you would face the American public and then face the world and give your own personal accounts of how this situation happened and, most importantly, what we are going to do to see that it never happens again. That is the executive and legislative branches working together.

We are proud of the democracy here in America. It is an open process, and we are going to show the world how we fairly, firmly, and calmly deal with this situation.

Thank you.

Senator Levin.

STATEMENT OF SENATOR CARL LEVIN

Senator LEVIN. Thank you, Mr. Chairman.

First I want to join you in welcoming our witnesses this morning. I want to join you in thanking each one of them for their service to our Nation. Most importantly of all, I join you, Mr. Chairman, in asking our witnesses to pass along to the troops under their command the gratitude of every member of this committee and of our Nation for their service.

The allegations of abuses of Iraqi detainees have shocked our country and shocked our justifiably proud Armed Forces and their families. The committee's hearing this morning is part of our continuing effort to investigate and find out the full extent of these abuses and how they could have happened. Insisting on accountability will help prevent future abuses, and hopefully help restore the credibility of our Nation within Iraq, the region, and throughout the world.

The inquiry is not just about the behavior of a few soldiers at a detention facility. We, of course, must do whatever we can to ensure that the perpetrators of the abuses are held accountable. But those who were responsible for encouraging, condoning, or tolerating such behavior, or who established or created an atmosphere or climate for such abusive behavior, must also be held accountable.

The February 2004 report of the ICRC presents an overview of documented abuses that extend beyond the conduct of interrogations at one cell block in one detention facility. The report sets forth an extensive list of methods of ill treatment used "in a systematic way" by MI at Abu Ghraib and a number of other facilities. The abuses that are alleged apparently are not limited to detention facilities. Many of the alleged violations are reported to have occurred at the time of arrest. This is particularly disturbing, given the statement in the ICRC report that "certain military intelligence officers" told the ICRC that, in their estimate, between 70 and 90 percent of the persons deprived of their liberty in Iraq had been arrested by mistake.

In addition, according to their report, the ICRC, in May 2003, handed over to CENTCOM, in Doha, a memorandum based on "over 200 allegations of ill treatment of prisoners of war during capture and interrogation." I know that General Abizaid and General Sanchez will inform us today about when the ICRC report and other reports of abuse were brought to their attention and what actions were ordered to address those concerns.

In addition to reports that were made in the field, ICRC President Kellenberger stated that he briefed administration officials, including Coalition Provisional Authority (CPA) Administrator Paul Bremer, Secretary Powell, National Security Advisor Rice, and Pentagon officials, concerning allegations of abuse on a number of occasions, including in early- and mid-2003 and January 2004. We would be interested in hearing from our witnesses about what word, if any, was received from Washington or Ambassador Bremer as a result of those allegations of abuse being brought to the attention of administration officials.

Finally, I want to commend you, Mr. Chairman, for your determination to carry out the oversight responsibility of this committee. Committees of jurisdiction have an obligation to understand these events, to deter future abuses, and to help assure proper accountability. Mr. Chairman, you are leading this committee in a responsible way to do just that, and the Nation is in your debt for carrying out your duty as you see it.

Chairman WARNER. Senator Levin, the committee is acting as a whole. All members, and most especially yourself, have been responsible for conducting ourselves, I think, in strict accordance with the institution of the Senate and in the best interest of the Constitution.

Gentlemen, I ask you to rise. [Witnesses sworn.]

Chairman WARNER. General Abizaid.

**STATEMENT OF GEN JOHN P. ABIZAID, USA, COMMANDER,
UNITED STATES CENTRAL COMMAND**

General ABIZAID. Thank you, Mr. Chairman.

Senator Warner, Senator Levin, and members of the committee:

A few days ago I had the honor to talk to the class of 2004 at West Point, a group of young men and women who have dedicated themselves to service to the Nation, and who clearly understand that within the first year of their duties they will likely find themselves in combat, probably in the CENTCOM theater of operations. I could have just as easily been talking to young cadets at the Air

Force or Naval Academies, or at countless other colleges or places where our young people are about to be commissioned as officers in our Armed Forces. One of the most important messages I had for them is my deep belief in the principle that officers of the United States military are responsible; that, when in charge, we must be in charge. This is as true for the lowest second lieutenant in the chain of command as it is for me. Every officer is responsible for what his or her unit does or fails to do. I accept that responsibility for CENTCOM.

I come before you as a senior regional commander to address the Abu Ghraib prison case, and, at the same time, I hope you will allow me to discuss the conduct of the war, not only in Iraq, but throughout the region.

As all of you understand, both General Sanchez and I, as members of the chain of command, have yet to examine all the facts about the incidents at Abu Ghraib and have made no judgement as to the guilt or innocence of any person associated with events there, nor have we precluded further action against others that additional testimony or evidence may indicate acted inappropriately or failed in their duties.

From evidence already gathered, we believe that systemic problems existed at the prison that may have contributed to events there. Other investigations are currently underway, and we will consider their findings carefully once they become available. We will follow the trail of evidence wherever it leads. We will continue to correct systemic problems. We will hold people accountable. In accordance with the UCMJ, we will take appropriate action.

On my way back to the States, I stopped and talked to many of the region's top military and political leaders to discuss Abu Ghraib and the situation in Iraq to assess the damage that this incident has done to our reputation. They, like us, and like the many Iraqis who talked to me before I last left Iraq, were shocked, disgusted, and disappointed at the images of abuse. Yet all of them expressed confidence that our system could and would produce answers and hold people accountable.

If we endanger our ability to see that justice is served, through failure to thoroughly investigate allegations, by inadvertently exerting inappropriate command influence, or through the inappropriate handling of evidence, we will do ourselves, the region, and Iraqis, in particular, a great disservice.

As concerned as the good people of the region are about what happened at Abu Ghraib, they are more concerned about our willingness to stay the course in Iraq and Afghanistan. They are more worried that we will lose our patience with the difficult task of stabilizing those places, and we will walk away, come home, and bring up the drawbridges and defend "Fortress America." For some of the nations in the region, our departure could be fatal. I reassured our friends that we are tough, that we cannot be defeated militarily, and that we will stay the course.

We know that we must move quickly from occupation to partnership in Iraq. We know that we must help the Afghan Government of President Karzai extend its influence throughout its own land. We must find and destroy al Qaeda and its ideological partners wherever we find them, and we must help the nations of the Mid-

dle East help themselves in fighting this desperate war against terror and extremism. We have given much blood and treasure since September 11, and we will give more.

Allowing moderation to succeed in a region where talented people seek prosperity and hope for their children is as an important victory as were our struggles against totalitarian regimes in World War II. Our enemies are in a unique position, and they are a unique brand of ideological extremists, whose vision of the world is best summed up by how the Taliban ran Afghanistan. If they can outlast us in Afghanistan and undermine the legitimate government there, they will once again fill up the seats at the soccer stadiums and force people to watch executions. If, in Iraq, the culture of intimidation practiced by our enemies is allowed to win, the mass graves will fill again.

Our enemies kill without remorse, they challenge our will through the careful manipulation of propaganda and information, and they seek safe havens in order to develop weapons of mass destruction (WMD) that they will use against us when they are ready. Their targets are not Kabul and Baghdad, but places like Madrid and London and New York. They are a patient and despicable enemy who seek to break our will, to terrorize us in such a manner as to cause us to leave the fight, to isolate us from our allies, to destroy those who seek a better future, and to wreck the patient work required to build reliable infrastructure and sophisticated economic structures. Unlike us, they will not hold themselves accountable for their outrages.

Our enemies believe they have scored a great victory in Madrid. They believe they changed a government and forced a valued ally off the battlefield. They see before them elections in Iraq, elections in Afghanistan, and, indeed, elections here at home and elsewhere. They see us mired in scandal and preoccupied with failure.

We should not kid ourselves about the violent times ahead. Yet we should also understand that despite the images of Abu Ghraib and burning High Mobility Multipurpose Wheeled Vehicles that constantly play on our media screens, we are winning the battle against extremism. Our troops are confident. They win tactical battle after tactical battle. They work with Iraqis and Afghans to build viable security forces. One day these viable security forces will allow us to come home. They know that the enemy is elusive and dangerous, and they know that they need to fight this war with balanced ferocity and compassion.

As we fight this most unconventional war of this new century, we must be patient and courageous. It will require a great amount of intelligence work. We must focus all of our national power, and recognize that this war requires as much political, economic, diplomatic, and national willpower to win as it does the courage to fight and to sacrifice with our young people in harm's way.

There are more people in the region who value peace over terrorism, who know that moderation brings prosperity and hope for their children. They also know that if they cannot stand alone, they certainly cannot expect that the United States of America will walk away from them.

Our gift to them has to be to give them a chance to win. Our great gift to ourselves will be to show a great and open demonstra-

tion that the rule of law applies in time of war, that despite the great demands of the day-to-day battles, we will fix what is broken, and we will let justice be served.

No doubt, we have made mistakes in Abu Ghraib. We have suffered a setback. I accept responsibility for that setback. But the failures of a few will not keep the many courageous young men and women of ours from accomplishing their dangerous and important work to defend the Nation abroad.

I thank the committee.

Chairman WARNER. Thank you, General, for a very good statement.

General Sanchez.

**STATEMENT OF LTG RICARDO S. SANCHEZ, USA, COMMANDER,
MULTI-NATIONAL FORCE—IRAQ**

General SANCHEZ. Mr. Chairman, members of the committee, thank you for the opportunity to appear before the committee and talk to you about events in Iraq, and specifically the events at Abu Ghraib.

Before I talk about these events, I am proud to report that over 150,000 coalition military personnel are doing great work in Iraq under very difficult circumstances. They are fighting an insurgency, rebuilding and protecting infrastructure, and setting the conditions for the inevitable turnover to an interim government on the June 30. Those soldiers, sailors, airmen, and marines of America, and the people who support them, are stunned, disappointed, and embarrassed by the events that transpired at Abu Ghraib prison. However, like me, these great service members also understand that we must continue with our mission.

Regarding the events at Abu Ghraib, we must fully investigate and fix responsibility as well as accountability. I am fully committed to thorough and impartial investigations that examine the role, commissions, and omissions of the entire chain of command, and that includes me. As a senior commander in Iraq, I accept responsibility for what happened at Abu Ghraib, and I accept, as a solemn obligation, the responsibility to ensure that it does not happen again.

We have already initiated courts-martial in seven cases, and there may very well be more prosecutions. The Army Criminal Investigative Division's (CID) investigation is not final, and the investigation of MI procedures by Major General Fay is also ongoing. We may find that the evidence produced in these investigations not only leads to more courts-martials, but cause us to revisit actions previously taken to determine whether to initiate judicial or non-judicial action in cases which may have been handled to date by adverse administrative action.

In this regard, I must be very circumspect in what I say. We must let our military justice process work. It is a process in which the American people can and should have confidence, and one in which I take great pride.

I cannot say anything that might compromise the fairness or integrity of the process, or in any way suggest the result in a particular case. I have taken an oath to support and defend the Constitution of the United States, and that includes ensuring that all per-

sons receive a fair trial and, if found guilty, appropriate punishment.

This respect for the rule of law has been a guiding principle for my command. There is no doubt that the laws of war, including the Geneva Conventions, apply to our operations in Iraq. This includes interrogations. I have reinforced this point by way of orders and command policies. In September and October 2003, and in May 2004, I issued interrogation policies that reiterated the application of the Geneva Conventions and required that all interrogations be conducted in a lawful and humane manner with command oversight.

In October 2003, I issued a memorandum for all coalition forces personnel that was titled "Proper Treatment of Iraqi People During Combat Operations." I reissued this memorandum on January 16 after learning about the events that had taken place at Abu Ghraib.

On March 4, 2004, I issued my Policy Memorandum Number 18, titled "Proper Conduct During Combat Operations." This document, which I also reissued in April, emphasized the need to treat all Iraqis with dignity and respect. This policy memorandum also contained a summary for distribution, down to the individual soldier level, that provided clear guidance and mandated training on the following points: Follow the law of war and the rules of engagement (ROE); treat all persons with humanity, dignity, and respect; use judgement and discretion in detaining civilians; respect private property; and treat journalists with dignity and respect.

With regards to Abu Ghraib, as soon as I learned of the reported abuses, I ensured that a criminal investigation had been initiated, and requested my superior appoint an investigating officer to conduct a separate administrative investigation under Army Regulation 15-6 into this matter. Within days of receiving the initial report, I directed suspension of key members of the chain of command of the unit responsible for detainee security at Abu Ghraib.

The criminal investigation, while still underway, resulted, thus far, in the decision to initiate court-martial proceedings against seven individuals. The administrative investigation that was conducted by Major General Taguba has caused me to change the way we conduct detention, internment, and interrogation operations.

One significant change has been the addition to my staff of a general officer with responsibility for detention operations. Major General Geoffrey Miller was assigned this task, and has taken numerous positive steps to eliminate the possibility that such abuse could occur in the future.

Well before I received the January 14 report and viewed the shocking photographs later on, I had directed steps be taken to improve the overall condition of detainees at Abu Ghraib. Back in August 2003, I requested that subject-matter experts conduct a comprehensive assessment of all detention operations in Iraq. This was the genesis for the report completed by Major General Ryder, the Provost Marshal General of the Army.

In September, a team headed by General Miller assessed our intelligence interrogation activities and humane detention operations. We reviewed the recommendations with the express understanding, reinforced in conversations between General Miller and me, that

they might have to be modified for use in Iraq, where the Geneva Conventions were fully applicable.

Plans for the new detainee camp at Abu Ghraib, which will now be called Camp Redemption, were begun in November of 2003 in order to relieve overcrowding at the facility. After a series of mortar attacks against the facility in September which killed and injured both Iraqi detainees and U.S. soldiers, I directed increased force-protection measures be taken in order to protect coalition forces and detainees. Plans to upgrade the facilities for soldiers and detainees were also implemented.

Finally, the rate at which detainee case files were reviewed and recommended for release or continued internment was increased, both in November 2003 and again in February 2004, in order to ensure that only those detainees who posed a threat to security were detained. Indeed, our February 2004 changes resulted in the review of over 100 cases per day. The terrible events that occurred in the fall of 2003 have obviously highlighted additional problems that we have moved quickly to address.

While horrified at the abusive behavior that took place at Abu Ghraib, I believe that I have taken the proper steps to ensure that such behavior is not repeated. I further believe that my actions have sent the correct message that such behavior is inconsistent with our values, our standards, and our training. I have faith in our military justice system to resolve the cases brought before it.

I would like to read the concluding paragraph from my memorandum to the command on proper conduct during combat operations. I believe it is an accurate summary of my standards and expectations. "Respect for others, humane treatment of all persons, and adherence to the law of war and rules of engagement is a matter of discipline and values. It is what separates us from our enemies. I expect all leaders to reinforce this message."

In closing, the war in Iraq continues against a relentless enemy that is focused on preventing the Iraqi people from achieving their dream of freedom, prosperity, and security. This awful episode at Abu Ghraib must not allow us to get distracted. America's Armed Forces are performing magnificently, sacrificing every single day to defeat an enemy that is ruthless and elusive in its quest to terrorize Iraq and the world. The honor and value systems of our Armed Forces are solid and the bedrock of what makes us the best in the world. There has been no catastrophic failure, and America's Armed Forces will never compromise their honor. America must not falter in this endeavor to defeat those who seek to destroy our democratic value systems. In Iraq, the coalition military, including our 130,000 Americans, remain focused, and I guarantee you they will not fail.

Thank you, Mr. Chairman.

Chairman WARNER. Thank you, General. That is a very comprehensive statement, and I would ask, on behalf of the committee, that the documents that you referred to in your testimony—could copies be provided to the committee?

General SANCHEZ. We will comply, Mr. Chairman.

[The information referred to follows:]

UNCLASSIFIED//For Official Use Only

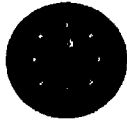
REPLY TO
ATTENTION OF

HEADQUARTERS
COMBINED JOINT TASK FORCE SEVEN
 BAGHDAD, IRAQ
 APO AE 09335

Policy Memorandum #18

CJTF7-CG

4 March 2004

MEMORANDUM FOR All Coalition Forces Personnel

SUBJECT: Proper Conduct During Combat Operations

1. Purpose. This memorandum reemphasizes the responsibility of Coalition Forces to treat all persons with dignity and respect. It reiterates the obligation of Coalition personnel to comply with the law of war.
2. Humane Treatment of the Iraqi People. Coalition Forces are committed to restoring the human rights of the Iraqi civilians and the rule of law. We must treat all civilians with humanity, dignity and respect for their property and culture. Coalition Forces preserve human life by avoiding civilian casualties and rendering prompt medical attention to persons injured during combat operations. Use judgment and discretion in deciding whether to detain civilians. In all circumstances, treat those who are not taking an active part in hostilities, including prisoners and detainees, humanely. Remain particularly aware of heightened sensitivity in the Iraqi and Islamic cultures concerning the treatment of females. Whenever possible, females will be searched in a non-public location; unless absolutely necessary, male soldiers will not search females.
3. Force Protection and the Lawful Use of Force. We are conducting combat operations in a complex, dangerous environment. Coalition Forces must remain bold and aggressive, yet disciplined, in their use of force. When in contact with the enemy, use only that force necessary to accomplish the mission while minimizing unintended damage. Our posture must be strong and determined, while remaining firmly in control of the destructive power of our weapons. You have learned the principles of the law of war throughout your military careers. As professional soldiers, you must follow them, and comply with the rules of engagement. Before engaging any target, you must be reasonably certain that it is a legitimate military target. Self-defense is always authorized.
4. Treatment of Journalists. Coalition Forces will treat journalists and media representatives with dignity and respect. Verbal or physical harassment of media members is inconsistent with our values as professional soldiers. Media coverage, in large part, shapes domestic and international public perception of the security environment in Iraq. The media's mission to report the story of the reconstruction and security of Iraq is important to our mission. Independent coverage by local, national and international media will be facilitated to the maximum extent possible consistent with force protection and security. Journalists and media representatives must be permitted to travel without undue hindrance in order to pursue their profession. They can be expected to operate as both embedded and independent reporters, provided they do not represent a risk to Coalition Forces, CPA members or the Iraqi Security Forces. Their equipment will be seized, and film or digital disks erased, only

CJTF7-CG
SUBJECT: Proper Conduct During Combat Operations

when required for imperative reasons of security and in accordance with procedures stated in CJTF-7 Frago 1176, Treatment of Journalists/Media Representatives, 041815DEC03.

5. A summary of "Rules of Proper Conduct During Combat Operations" is enclosed. This memorandum and the Rules of Proper Conduct will be distributed down to the platoon level. Leaders will ensure that all CJTF-7 personnel are trained on the Rules of Proper Conduct. Additionally, leaders will ensure that all CJTF-7 personnel receive refresher training on the rules of engagement, which includes training on the disciplined use of force, posted on the CJTF-7 CENTRIX web-site (Staff Section/SJA/Rules of Engagement/ROE Vignettes.ppt (30 JAN 04)).

6. Conclusion. Respect for others, humane treatment of all persons, and adherence to the law of war and rules of engagement is a matter of discipline and values. It is what separates us from our enemies. I expect all leaders to reinforce this message.

Encl
as

RICARDO S. SANCHEZ
Lieutenant General, USA
Commanding

DISTRIBUTION:
A

Rules of Proper Conduct During Combat Operations

1. **FOLLOW THE LAW OF WAR AND RULES OF ENGAGEMENT.**
 - Use only that amount of force necessary to accomplish your mission. Engage only positively identified targets. Use precision in every engagement to minimize unintended damage.
 - Remain bold and aggressive, yet disciplined, in the use of force.
 - SELF-DEFENSE IS BOTH AUTHORIZED AND REQUIRED.

2. **TREAT ALL PERSONS WITH HUMANITY, DIGNITY AND RESPECT.**
 - Remain culturally aware. When uncertain as to whether your actions will offend Iraqi or Islamic culture discuss your actions with a chaplain or other knowledgeable person.
 - Render prompt medical care to persons injured during operations.
 - Respect the honor of women.
 - Search females with female soldiers in a non-public area whenever possible; unless absolutely necessary, male soldiers will not search females.

3. **USE JUDGMENT AND DISCRETION IN DETAINING CIVILIANS.**
 - Detain persons only when necessary and in accordance with the rules of engagement.
 - Treat all detainees humanely – if force is required, use only minimum necessary force.
 - Use hoods only when necessary for imperative reasons of safety or security, and consider the use of blindfolds as a less demeaning way to limit detainees' vision.
 - Fill out the CPA Apprehension Form legibly and completely. Provide the details that will allow your higher headquarters to know whether to keep a person in detention as a criminal or a threat to security.

4. **RESPECT PRIVATE PROPERTY.**
 - Minimize unintended damage.
 - Seize property only if required as evidence, contraband or former enemy property.
Document the seizure of all property so that it may be returned to its owner when no longer needed as evidence or for intelligence exploitation.
 - Provide a receipt for private property seized during an operation.
 - Soldiers will not personally retain property taken during an operation – keeping this property for personal use is stealing.
 - Provide claims forms to potential civilian claimants if operations result in unintended damage to innocent persons or property.

5. **TREAT JOURNALISTS WITH DIGNITY AND RESPECT.**
 - Do not verbally or physically harass journalists or media representatives.
 - Do not seize journalists' equipment, or erase film or digital disks, unless required for imperative reasons of security.

Chairman WARNER. Thank you very much.
General Miller.

STATEMENT OF MG GEOFFREY D. MILLER, USA, DEPUTY COMMANDER FOR DETAINEE OPERATIONS, MULTI-NATIONAL FORCE—IRAQ

General MILLER. Mr. Chairman, members of the committee, thank you for affording me this opportunity to appear this morning. While I have no opening statement, I do stand with the statements of General Abizaid and General Sanchez.

Thank you.

Chairman WARNER. Thank you very much.

Colonel Warren, do you wish to add anything?

STATEMENT OF COL MARC L. WARREN, STAFF JUDGE ADVOCATE, CJTF-7

Colonel WARREN. Mr. Chairman, I have no opening statement, but I would be happy to respond to any questions.

Chairman WARNER. Thank you very much.

We will have a 6-minute round and I advise the committee that, in consultation with General Abizaid and the ranking member, there will be a brief closed session following the open session, such that we can receive some classified material.

General Abizaid, what policies has CENTCOM established for the conduct of interrogations in detainee operations? When were these policies established? What allegations of abuse are you aware of that could have also occurred in Afghanistan? Are the policies being uniformly applied and enforced throughout your area of responsibility (AOR)?

General ABIZAID. Thank you, Mr. Chairman.

As I believe the Army has come over and discussed with the committee, the total number of detainee abuse cases that have been investigated since, I believe, the beginning of the conflict in Afghanistan is around 75. Of course, there are some death investigations, as well. We have homicide investigations that go back as far as December 2002 in Afghanistan that we absolutely have to move on and understand what happened there. We are working with the Army CID to understand that. But I believe the committee has the statistics on abuse.

Abuse has happened. Abuse has happened in Afghanistan, it has happened in Iraq, it has happened at various places. The question is, is there a systemic abuse problem with regard to interrogation that exists in the CENTCOM AOR?

Yesterday—and I know the committee has not had a chance to review it yet—I did see the preliminary findings of a Department of the Army Inspector General (IG) investigation that talked about problems in training, problems in organization, very specific changes that will need to be made in doctrine, et cetera. I specifically asked the IG of the Army if he believed that there was a pattern of abuse of prisoners in the CENTCOM AOR. He looked at both Afghanistan and Iraq, and he said no. I sent my IG out in August of last year, asking him the same question, Are we treating people with dignity and respect?

Chairman WARNER. What findings did he report back when you sent him out in August?

General ABIZAID. He came back and said that we were struggling with the number of prisoners, we were struggling with the facili-

ties, and we were struggling to, in particular, deal with criminal detainees that needed to go into an Iraqi criminal detention system that still did not exist.

Chairman WARNER. But he did not discover any of the evidence that is now being revealed about these abuses?

General ABIZAIID. No, sir, he did not.

Chairman WARNER. All right. That is a direct answer.

Can you provide the committee, without violating UCMJ procedures, your own personal observations as to what you believe happened from the breakdown of the orders to General Sanchez, as clearly documented here this morning, and where it happened?

General ABIZAIID. Sir, I think you know that Major General Fay is still conducting—

Chairman WARNER. Yes.

General ABIZAIID.—an investigation, and so I am not quite ready to say where I think all the breakdowns were. But it is clear that there were some breakdowns in procedures, in access, in standards of interrogation, in confusion between the roles of what the MI people were doing, versus the MPs. There was also, clearly, criminal misconduct that took place.

Chairman WARNER. All right.

General ABIZAIID. The criminal misconduct is not the subject of any order or policy that I believe exists anywhere.

Chairman WARNER. There has been, of course, concern that the initial steps by the chain of command were directed at a group of enlisted people who are now subject to various forms of UCMJ accountability. Can you assure this committee that you will diligently pursue all evidence and—no matter how high up the chain, or sideways or down the chain—all persons will be brought forward, subject to the UCMJ?

General ABIZAIID. Sir, I assure the committee that we will do that.

Chairman WARNER. Fine.

General ABIZAIID. I can also assure the committee that I have been in this business a long time, and when General Sanchez called me up and told me, I think, probably within 24 hours of the evidence being handed to his CID people in Baghdad, he followed it up very shortly with a decision to suspend the entire chain of command, which is a pretty strong action that does not just focus at a low level. He initiated investigations and he moved ahead in a way that I thought was commendable.

Chairman WARNER. Do you feel that the UCMJ procedures and other regulations impeded, in any way, your responsibility to keep the civilian control structure back in Washington advised?

General ABIZAIID. No, sir, it did not impede us. As always, we believe that we have to do everything possible to protect the evidence that is available to keep the investigatory information within investigatory channels, and that is what we tried to do.

Chairman WARNER. You tried to do that in a timely fashion.

General ABIZAIID. That is what we tried to do, yes, sir.

Chairman WARNER. General Sanchez, on November 19 you directed that the commander of the 205th MI Brigade assume command of all units and operations in the Abu Ghraib prison. Why did you put MI in charge of the prison? In your view, did this new

command arrangement improve intelligence and detainee operations? What objections did General Karpinski, commander, have concerning the change in command responsibilities?

General SANCHEZ. Mr. Chairman, on November 19, I issued a Fragmentary Order that placed all elements at Abu Ghraib under the tactical control of Colonel Pappas, the 205th MI commander. The specific order stated that this was for forward-operating base (FOB) protection and for security of detainees. The context of the order was that we had been receiving significant amounts of direct and indirect fire, and, during the conduct of one my visits, I had found that force protection and the defensive planning of that FOB was seriously lacking, and I needed to get a senior commander in charge of the defense of that FOB, and that was the purpose of the order.

The order did not intend to eliminate any of the responsibilities of the 800th MP Commander, and that was a specific purpose for the tactical control (TACON). TACON placed the 320th under the 205th MI Brigade Commander, and what that does—specifically, it gives the MI brigade commander authority to conduct local direction and control of movements or maneuvers to accomplish the mission at hand. All of the other responsibilities for continuing to run the prison, for logistics, training, discipline, and the conduct of police—or, correction—of prison operations remained with the 800th MP Brigade Commander. There was never a time where General Karpinski surfaced to me any objections to that TACON order.

Chairman WARNER. Thank you.

General Abizaid, you have, quite properly, advised this committee this morning that you are fighting a war. This responsibility, occasioned by these abuses, has taken a measure of your time, but you have continued, and your troops have performed bravely.

Here is the question I put to you, eliciting your professional and personal view: Is the scheduled change of limited sovereignty on July 1 consistent and achievable, in your judgement, given the security situation?

General ABIZAID. Mr. Chairman, it is achievable, but it needs to emerge soon as to who is going to be in charge, what their names are, where they are going to be, and what they are going to do.

Chairman WARNER. That is on the Iraqi side.

General ABIZAID. That is correct.

Chairman WARNER. It is clear on our side that we have a United States Ambassador in place to provide the security?

General ABIZAID. Sir, we are going to be there, no matter what.

Chairman WARNER. Thank you.

Senator Levin.

Senator LEVIN. Thank you.

General Sanchez, your answer to Senator Warner about who was responsible for the MP units conducting detainee operations at that facility leaves me uncertain now, because General Taguba says that your order of November 19 effectively made the MI officer, rather than the MP officer, responsible for the MP units conducting detainee operations. That is a quote. Do you disagree with General Taguba, then, on that point?

General SANCHEZ. Senator, the purpose of the order was as described. It was to ensure that I had synchronized FOB defenses,

and that was the purpose for the TACON order that was issued to the MP unit at that installation.

Senator LEVIN. In addition to its purpose, though, General Taguba said that the MI officer then became responsible for the MP units conducting the operations. Do you differ with that?

General SANCHEZ. They were responsive to the MI officer for the specific purpose of defending the FOB, Senator.

Senator LEVIN. That did not, then, include conducting detainee interrogations.

General SANCHEZ. That is exactly right, sir. It did not include that.

Senator LEVIN. There is a difference there between you and General Taguba.

General SANCHEZ. Yes, sir.

Senator LEVIN. General Abizaid, in May 2003, the ICRC sent to the coalition forces a memorandum based on over 200 allegations of ill treatment of prisoners during capture and interrogation at collecting points, battle-group stations, and temporary holding areas, according to the ICRC report, which I am now reading. It said here that CENTCOM in Doha received this memorandum. I am wondering if, in fact, you remember receiving that memorandum and what action you took on it.

General ABIZAID. There are some ICRC reports, Senator, that we received. Which one are you talking about?

Senator LEVIN. May 2003.

General ABIZAID. I know that the May 2003 report was received at our headquarters, that is correct.

Senator LEVIN. What action do you remember taking?

General ABIZAID. I was the deputy commander at the time. I know that we discussed the report, we sent it forward to the Coalition Forces Land Component Commander, General McKiernan, and we asked for his take on it.

Senator LEVIN. Did you receive a report from him, do you remember?

General ABIZAID. I do not believe we received a report in writing. I do not recall having a lot to do with this particular report, or paying much attention to it.

Senator LEVIN. Perhaps you could check your records and supply to the committee any documents relative to that.

General ABIZAID. I will, sir.

[The information referred to follows:]

CENTCOM was unable to locate the requested document. A memo is attached explaining.



UNITED STATES CENTRAL COMMAND
OFFICE OF THE CHIEF OF STAFF
7115 SOUTH BOUNDARY BOULEVARD
MACDILL AIR FORCE BASE, FLORIDA 33621-5101

NOV 05 2004

CCCS

MEMORANDUM FOR CONGRESSIONAL COMMITTEE

SUBJECT: Combined Forces Land Component Command Response to International Committee of the Red Cross's May 2003 Report

1. During the SASC hearings on 19 May 2004, Senator Levin requested that Commander, United States Central Command, supply the committee with any documents relative to a 12 May 2003 report made by the International Committee of the Red Cross.
2. A diligent and thorough search of records held at United States Central Command and Combined Forces Land Component Command revealed that neither command had any documents responsive to the report made by the International Committee of the Red Cross.
3. My POC for this action is LTC John S. T. Irgens, DSN 651-6422.

JOHN G. CASTELLAW
Major General, USMC

Senator LEVIN. In early July, according to the ICRC, they sent to the coalition forces a working paper detailing approximately 50 allegations of ill treatment in the MI section of Camp Cropper. This, according to their report, set forth requiring or using stress positions for 3 or 4 hours, physical hits, prolonged exposure to sun, and a number of other allegations. Can you tell us whether the early July ICRC report was received at headquarters?

General ABIZAID. No, and we have a real problem with ICRC reports and the way that they are handled and the way that they move up and down the chain of command. For example, the February report of 2004, I first read in May.

Senator LEVIN. But relative to the early July report—

General ABIZAID. I will not make any excuses for it, Senator. I will just say that we do not all see them. Sometimes it works at a lower level. Sometimes commanders at the lowest level get the report, and they work on it confidentially. I think what we have to do is have a system, when there is something that comes to the attention at any level of command, that is not being worked through at the lower level, but that it surface all the way up through the chain of command. So we have a problem there that has to be fixed.

Senator LEVIN. Thank you.

General Sanchez, is there a record of the ICRC working paper being received by you or at your level?

General SANCHEZ. Is this the July paper?

Senator LEVIN. The July working paper detailing 50 allegations of ill treatment.

General SANCHEZ. Not that I am aware of, Senator.

Senator LEVIN. So there is no indication at your level, at your headquarters, that that document was ever received?

General SANCHEZ. No, Senator. The working paper that I am aware of that made it to my headquarters was the November paper.

Senator LEVIN. The Interrogation Rules of Engagement is a document which was presented to this committee by General Alexander, saying that the ROE that were in effect at the Combined Joint Task Force 7 (CTJF-7) in Iraq prior to 2003 are set forth on a piece of paper, which—are you familiar with it?—called “Interrogation Rules of Engagement”?

General SANCHEZ. Yes, sir, I have seen that.

Senator LEVIN. Did you approve this? Did you have legal advice? What is this document that General Alexander told us were the ROE that were in effect at the CJTF?

General SANCHEZ. Sir, the first time I saw that paper was when it was shown in one of the prior hearings in this same forum.

Senator LEVIN. So that he would—

General SANCHEZ. I had no role in preparing it or approving it.

Senator LEVIN. All right. So he was in error, then, relative to that? General Alexander, then, would have been in error if he said this was the document—

General SANCHEZ. Right, sir. I have never seen that, I had never approved it, and I had no part in putting that together, sir.

Senator LEVIN. I do not believe this committee has your October 12 policy statement. If I am wrong, then fine. But would you provide that October 12 statement to the committee?

General SANCHEZ. Yes, sir.

[The information referred to follows:]

The requested document was provided to the committee as an attachment to the question for the record (QFR) 76 for Lieutenant General Sanchez.

Senator LEVIN. Finally, the newspaper reported that a hundred or so high-value detainees do not fall under your command, General Sanchez, but are the responsibility of General Dayton, who is commander of the Iraq Survey Group and reports directly to General Abizaid. Is that accurate, as far as you know?

General SANCHEZ. Yes, sir, that is accurate.

Senator LEVIN. Do you know why?

General SANCHEZ. My MPs provide security at that—

Senator LEVIN. Can you just tell us, then, why that was done that way, General Abizaid?

General ABIZAID. Sir, that was done that way because the people at Camp Cropper happened to be those people who had theoretical information concerning WMD information, and also were the high-value detainees who we hope someday to turn over to a legitimate Iraqi government for trial.

Senator LEVIN. But why should they be treated differently from other detainees, separated out that way?

General ABIZAID. They were separated out that way to ensure that we understood, I guess I would call it, the strategic environ-

ment, as opposed to the tactical environment, where we would get information from lower-level detainees. It was established that way as a result of discussions that had taken place here in Washington regarding having a better and more efficient way to really understand what was going on with regard to WMD.

Senator LEVIN. That was all, then, WMD-information related, basically?

General ABIZAID. It was, sir, but it was also dealing with very senior levels of the former Iraqi Government.

Senator LEVIN. Thank you.

Chairman WARNER. Thank you very much, Senator.

I have just been told that the DOD has informed the committee that another disk of pictures has been located, and I will soon advise the committee on the conditions under which that can be viewed.

Senator McCain.

Senator MCCAIN. Thank you, Mr. Chairman.

I want to thank the witnesses, particularly Generals Miller, Abizaid, and Sanchez, for their outstanding service to our Nation under the most difficult circumstances. I was pleased to hear that you were here on other business and did not have to be called back from the theater of operations. I thank you for all the time and effort you have devoted to trying to resolve this terrible issue. We are very grateful for that and for your appearance here today.

General Sanchez, according to a November 19, 2003, message, as you responded to questions from Senator Warner and Senator Levin, you transferred full responsibility to Colonel Pappas to assume full responsibility for Abu Ghraib and appointed the National Guard units to be under the tactical control of 205th MI Brigade Commander for security of detainees and FOB protection. I quote from your message. I think that is accurate.

In his statement to General Taguba, Colonel Pappas said, "Policies and procedures established by the joint detention and detention center at Abu Ghraib relative to detainee operations were enacted as a specific result of a visit by Major General Geoffrey Miller, Commander Joint Task Force Gitmo." He went on to say, "The key findings of his visit were that the interrogators and analysts developed a set of rules and limitations to guide interrogation and provide dedicated MPs to support interrogation operations." I repeat, "and provide dedicated MPs to support interrogation operations."

Now, General Sanchez, General Miller's report, as I understand it, had observations and recommendations. One of those recommendations was, "It is essential that the guard force be actively engaged in setting the conditions for successful exploitation of the internees."

Am I accurate so far, General Sanchez?

General SANCHEZ. Yes, Senator.

Senator MCCAIN. General Miller.

General MILLER. Yes, sir, you are.

Senator MCCAIN. Well, General Miller, do you believe that your instructions may have been misinterpreted?

General MILLER. Senator, I do not. On our visit to the JTF to be able to give an assessment of the intelligence function—it is three

major areas: intelligence fusion, the interrogation process, and humane detention—the team of 19 experts laid out those standards that would allow for humane detention, interrogation in accordance with the Geneva Conventions, and then recommended procedures by which intelligence could be fused more rapidly to provide actionable intelligence for units and for the JTF itself.

Senator MCCAIN. Well, thank you. But it seems to me that this order that I just quoted turned over certain MP duties to the control of Colonel Pappas and then certain things happened. According to General Taguba's report, soldiers were questioned who were involved in this.

Soldier number one, question: "Have you ever been directed by the MI, military intelligence, personnel or any government agency to soften up a prisoner prior to interrogation?"

Answer: "Yes. Sometimes they would ask me to show a prisoner, 'special attention.'"

Soldier number two: "Have you ever been told by MI personnel to work over a prisoner?"

"Yes. MI told us to rough them up to get answers from the prisoners."

"Why didn't you report the abuse?"

"Because I assumed that if we were doing anything wrong or out of the ordinary or outside the guidelines, someone would have said something. Also, the wing belonged to military intelligence, and it appeared military intelligence personnel approved of the abuse."

Soldier number three, question: "What can you tell us about the abuse of prisoners at Abu Ghraib?"

"Yeah, the MI staffs, to my understanding, have given compliments to us on the way we were handling the MI holds. Example being statements like: 'Good job. They're breaking down real fast,'" "They answer every question now. Keep it up," and "They're giving out good information."

Soldier number four: "Have you heard MI insinuate the guards to abuse inmates of any type of manner?"

"Yes."

"What was said?"

Answer: "They said, 'Loosen this guy up for us. Make sure he has a bad night. Make sure he gets the treatment.'"

Do you see my point, Major General Miller? According to General Taguba's report, there were at least a number of guards, MPs, who were under the impression, or stated that they were under the impression, that they were under specific directions of MI personnel to, "rough up, soften up, given 'em a bad night," et cetera. How do we respond to that, General Miller?

General MILLER. Senator, in the recommendations that we made—

Senator MCCAIN. This goes back to my first question. Does this lead you to believe that your orders were misinterpreted?

General MILLER. No, sir. The leadership that received the recommendations throughout the JTF had a clear understanding of the recommendations that we made in those three areas of intelligence fusion, interrogation, and humane detention that laid out those requirements, that laid the base that they must be in concert with the Geneva Conventions, and gave recommendations from our

experience about how those three functions could be done successfully.

Senator MCCAIN. There must have been a breakdown somewhere.

General MILLER. Sir, in my estimation, it was a breakdown in leadership on how follow-on actions may have occurred, but I was not present at that time, so it would be difficult for me to give a—

Senator MCCAIN. General Sanchez, my time is expired.

Chairman WARNER. Yes, go ahead.

Senator MCCAIN. General Sanchez, please?

General SANCHEZ. Senator, I wanted to make one clarification, that General Miller did not issue any orders, and he has not issued any orders, until he arrived as the deputy commanding general for detainee operations. Those orders were my orders, sir.

Senator MCCAIN. I guess my question was better directed to you. Were those orders misinterpreted?

General SANCHEZ. Sir, I do not believe those orders were misinterpreted. The procedures that General Miller and I had discussed, that he recommended, were very detailed, and it very clearly stated that MPs were involved in passive enabling of those operations and had no involvement in the conduct of interrogations. Those were the orders in the standard operating procedures (SOPs) that remained after General Miller's visit.

Senator MCCAIN. I thank the witnesses. My time has expired.

Thank you, Mr. Chairman.

Chairman WARNER. Thank you very much.

Senator Kennedy.

Senator KENNEDY. Thank you very much. General, I echo the sense that all of us greatly respect you and the troops who you are commanding. We have lost 23 very brave soldiers from my State of Massachusetts and we are all very mindful of the complexities and the difficulties that the uniformed service personnel are facing over there. So we thank you so much for your leadership and your careers of public service in serving our country.

General Sanchez, as an old MP myself, I am surprised that you think the MI are better at protecting the forces than the MPs, but we will leave that for another time.

When we had the SECDEF here, General Abizaid, last week, he denied that there was any failure to take any of these reports seriously. The military, not the media, discovered these abuses, he said. Specialist Joseph Darby reported the acts of abuse at Abu Ghraib prison in mid-January. According to Secretary Rumsfeld, by the next day, investigations were authorized.

Yet now we learn, both from the front page of The New York Times and the front page of The Wall Street Journal today, that the ICRC observed abuses in the prison during the two unannounced inspections in October 2003 and it complained in a strongly-worded written report on November 6. This report was reviewed by senior military officials in Iraq, including two advisors to General Sanchez, according to this report.

So it appears that the military's first reaction was to restrict future ICRC visits to Abu Ghraib. That is the story in here. After the ICRC had provided two critical reports, the reaction of the military

personnel who were dealing with the prison then was to restrict access. They said, "You have to give us notice." All of us understand what that means. If you are going to give notice prior to the inspections, it obviously compromises the inspections.

So according to those news reports, nothing was done in the prison for 2 months. The military previously acknowledged that the worst abuses continued into December 2003.

So we have the SECDEF saying one thing, and we are learning, from two newspapers, another story. That is why I think we were trying to find out exactly who was in charge and who bears the responsibility. These are completely conflicting stories that have come out within a period of just a few weeks here before this committee. I do not know whether you have any reaction to those stories, whether you had a chance to see those this morning.

I want to move on quickly. I suppose it is fair to ask, who in Iraq or in CENTCOM is responsible for receiving and responding to the reports of violations of international law or conventions by U.S. military personnel?

General ABIZAIID. I am responsible. If someone brings it to my attention, I am responsible, and I will not turn my back on any report that I receive.

Senator KENNEDY. Well, you obviously did not get these reports.

General ABIZAIID. No, I did not, but—

Senator KENNEDY. Well, I am asking who would have gotten these reports. Who would have received this report in the chain of command? General?

General SANCHEZ. Senator, the November report was received by the brigade commander. Then, as I find out now, the CJTF-7 staff assisted her in responding to that report.

Senator KENNEDY. Did that brigade commander receive all of the reports, or just who, institutionally—

General SANCHEZ. No, sir. What—

Senator KENNEDY.—receives, within your organization, any of the—like for the ICRC violations that come on in. Who is in charge on that? Who receives it?

General SANCHEZ. When the February 2004 report came in, that is when I found out that the November working papers had been issued to the brigade commander. At that point, I immediately changed the procedure and required that those reports come to me as the senior commander in the country. That is the procedure now.

Senator KENNEDY. There was no central receiving officer in charge prior to what you have just established? Is that right?

General SANCHEZ. Sir, prior to that, those all would come to the Staff JAG's Office. That was the repository, and he was the point of contact, in terms of commander—it was coming at the lowest level.

Senator KENNEDY. At the staff JAG officer—

General SANCHEZ. Yes, sir, that is correct.

General ABIZAIID. If I may, sir, this system is broken.

Senator KENNEDY. Okay. All right.

General ABIZAIID. We have to fix it.

Senator KENNEDY. Let me move on to General Miller. After your assessment of the detention interrogation in Iraq, you stated that

it was essential that the guard force be actively engaged in setting the conditions for the successful exploitation of the internees. General Taguba strongly disapproved of the recommendation, and he has stated that setting of the conditions for the detainees' successful exploitation through interrogation is fundamentally inconsistent with Army regulations and undermines the goals of running a safe and secure detention facility. That is what he testified to here, before this committee.

The New York Times reported yesterday that Colonel Thomas Pappas, who is the MI Brigade Commander at Abu Ghraib, told General Taguba that there were no safeguards to ensure the MPs at Abu Ghraib behaved properly in setting conditions for the detainees. "There would be no way for us to actually monitor whether that happened," Colonel Pappas said. "We have no formal system in place to do that." General Taguba also found the MPs had not been trained on the Geneva Conventions.

Was this not a catastrophic failure of leadership? How would you expect an average soldier in the Army to understand the term "successful exploitation" is not simply an euphemism for "anything goes"? Do you take responsibility for that failure?

General MILLER. Thank you, Senator.

The Taguba Report was very thorough, but I would like to clarify on this one point. The recommendation that my team made in the September time frame was that the MPs help set the conditions for successful interrogation as we had learned of their success in Guantanamo. The recommendation was that they conduct passive intelligence-gathering during this process. That meant to observe the detainees, to see how their behavior was, to see who they would speak with, and then to report that to the interrogators so the interrogators could better understand the human dynamic of the detainee as he would come into the interrogation booth.

We also recommended that the MPs, for security reasons, would accompany the detainee from the cell block, or the area where they were held, up to the interrogation booth, because they are security risks. Then the MP would wait somewhere else, and then accompany the detainee back. Our recommendation was that the MPs did not actively participate in any form of the interrogation itself. That was explained, in detail, to the chain of command. The SOP that laid that out was provided to them. It is about 200 pages long, and it goes into great detail about how this system works, because it says, in the SOP, that the MPs are not trained intelligence officers and should not initiate questioning or anything like that; they were just to be observers of that process. So that was the active support for the interrogation process that was recommended.

So, Senator, I will tell you, I believe that the recommendations we made, had they been implemented, would have not only increased the intelligence value of what was being done, but helped ensure that humane detention was accomplished throughout every facility.

Chairman WARNER. Thank you very much, Senator.

Before responding, General Sanchez, you made full reference to the brigade commander. Now, that would be General Karpinski?

General SANCHEZ. Yes, sir, that is correct.

Chairman WARNER. All right. I want the record to reflect that.

General ABIZAID. Mr. Chairman, just for the record, I would like to caution the committee. We still do not know what we do not know.

Chairman WARNER. That is very clear, and we recognize that. It has been a struggle to get a full understanding throughout this whole thing and that is why we have to entrust credibility to what the DOD, and the Army particularly, are doing now with a series of investigations. We fully appreciate that.

General ABIZAID. I think that Major General Fay's report will go a long way to make us understand this dynamic between MPs and MI, in particular, relative to Senator McCain's questions.

Chairman WARNER. I share that. Thank you, General.
Senator Roberts.

Senator ROBERTS. General Abizaid, you realize that your statement is contrary to the United States Senate, where we always know what we do not know. [Laughter.]

Let me say that I want to thank Senator McCain for his comments, because I think he spoke for the whole committee in reference to the contribution that you are making to our country and your service to our country, and I would like to associate myself with his remarks.

I am going to try to get my fast questions in to General Miller and basically—well, first let me ask of General Sanchez, no soldier would be justified in interpreting an order in such a way as to violate the UCMJ, is that correct?

General SANCHEZ. Sir, I would agree with that, absolutely.

Senator ROBERTS. So even if a soldier did misinterpret General Miller's recommendation, even though I doubt if they had it, to carry out these acts, it would not be an excuse, would it?

General SANCHEZ. Sir, that is correct. That is a basic instinct we have built into the soldier.

Senator ROBERTS. General Miller, would the abuse evidenced by the photos be permitted or condoned under any practices or policies that were recommended in your report?

General MILLER. Senator, they absolutely would not be.

Senator ROBERTS. Would the abuse evidenced in the photos be permitted or condoned at any of the practices or policies at Guantanamo Bay?

General MILLER. Senator, they would not.

Senator ROBERTS. Do you have any problem with General Ryder, who allegedly said there should be a firewall between the MPs and MI, given your rationale as to why they should work together, if we have the leadership and the training and the discipline that you have indicated that we now have?

General MILLER. Sir, our doctrinal publication said that there should be cooperation between the MPs and the intelligence function in a detention facility, but it does say there should not be any active participation by the MP force in any interrogations.

Senator ROBERTS. I have a staffer who works on the Intelligence Committee for me. I have the privilege of being chairman. He has been down at Guantanamo, in a Reserve capacity. He indicates that you made a remarkable turnaround down there. Many Senators have gone down. It only takes a day. I encourage every Sen-

ator here to do that. I credit you for improving a very difficult kind of situation.

In Iraq, it is my understanding that there are three prisons, five battalions. Four of the five are Reserves. Is that correct?

General MILLER. Senator, in the organization that I now lead, as the Deputy Commanding General for Detainee Operations, that is a correct statement.

Senator ROBERTS. After the incident at Abu Ghraib, how would you determine the leadership today in regards to discipline, training, and leadership of those personnel who you command as of right now?

General MILLER. Sir, in the first 30 days of my opportunity to work in this capacity, I was able to visit every facility and talk to virtually every leader and soldier who is involved in this. I will tell you that there is strong, positive, dynamic leadership throughout this chain of command.

Senator ROBERTS. So we have seen a hell of a change.

General MILLER. Sir, we have seen soldiers and leaders who know what standards are and execute them 7 days a week, 24 hours a day.

Senator ROBERTS. At Guantanamo Bay, you had one MP per two prisoners. In Iraq, you have one MP per eight and a half prisoners. Is that correct?

General MILLER. Sir, those are approximately the correct numbers.

Senator ROBERTS. Okay. But you have indicated that 50 percent of the prisoners in Abu Ghraib will be released. You have 3,800 prisoners now; that will bring it down to 1,500. What is happening to the 1,500? I understand there are 74 being tried by the Central Court of Iraq. Will all 1,500 be tried?

General MILLER. Sir, those approximately 1,500 security internees have been interned. That means that we have strong evidence that they have committed attacks on the coalition, and they will most likely be referred to the Central Criminal Court of Iraq for trial by the Iraqi system for those. There are a number of those, approximately 600 to 700, who are so dangerous that, should they be released back into Iraqi society, they would put that society at risk of a high probability of attack on their fellow citizens.

Senator ROBERTS. So they are the worst of the worst.

General MILLER. Sir, those are the worst of the worst.

Senator ROBERTS. If the ICRC investigated today, what would they find?

General MILLER. Sir, the ICRC is, as a matter of fact, investigating today. They are at Camp Bucca, which is one of our theater facilities down by Umm Qasr, on the southern border. They have found that we are making an enormous effort to improve conditions every day, that we take their findings seriously, and that we have addressed them. General Sanchez made a change when I arrived in the theater and put the ICRC responsibility directly on me. So all reports come to me, and I move them to General Sanchez and the command leadership as rapidly as possible.

Senator ROBERTS. So until we get the report by General Fay to assess responsibility and accountability, you think there has been a big change in regards to leadership, training, and discipline,

which are all directed at interrogation, to provide better intelligence to save Iraqi lives and American lives, is that correct?

General MILLER. Yes, sir, that is absolutely correct.

Senator ROBERTS. I thank you, Mr. Chairman.

Chairman WARNER. Senator Byrd.

Senator BYRD. Thank you, Mr. Chairman.

General Abizaid and General Sanchez, this travesty of justice occurred on your watch. The Iraqi prisoner abuse scandal has dealt a body blow to the heroic efforts of scores of American military troops and civilian workers in Iraq to win the hearts and minds of the Iraqi people. I do not know if that damage can ever be fully repaired. Certainly, a lot depends on what else might emerge about this scandal and on what you and the civilian leadership at the Pentagon do to set things right.

General Sanchez, you told Senator Levin that you never saw the ROE presented to this committee last week. If you did not see or set the so-called ROE for the interrogation of prisoners in Iraq, who does? Who does set them?

General SANCHEZ. Senator, what I stated was that I had not seen the specific slide that was referred to. I was the one who approved the interrogation ROE on September 12 and again in the October time frame, sir.

Senator BYRD. Does anyone in the civilian leadership of the Pentagon need to approve the rules of interrogation operations?

General SANCHEZ. Senator, those rules were forwarded to CENTCOM in the September time frame, and, based on the inputs from CENTCOM, resulted in the October memorandum.

Senator BYRD. I will ask the question again. Does anyone in the civilian leadership of the Pentagon need to approve the rules of interrogation operations?

General SANCHEZ. Sir, I do not know. As far as I know, there is no requirement for the civilian leadership to approve those rules of engagement.

General ABIZAID. Senator, I would say we are all responsible for making sure what happens in our organizations happens right. Things do not have to go all the way to the top to be approved. We know what is right and we know what is wrong.

Senator BYRD. The committee needs to know if you can answer this question. Does anyone in the civilian leadership of the Pentagon need to approve the rules of interrogation operations? If so, who?

General ABIZAID. My answer is no. It is our responsibility.

Senator BYRD. Then you are saying that nobody in the Pentagon approves these rules.

General ABIZAID. No, I am not saying that, sir.

Senator BYRD. Then what are you saying?

General ABIZAID. I am saying that the ROE for interrogators are a product of Army doctrine, of Army training, of practices in the field, and of commanders doing their job out there.

Senator BYRD. General Abizaid, if someone at the Pentagon is required to approve these ROE, surely you know.

General ABIZAID. If I knew, Senator, I would tell you. I would not forward any ROE to anybody. Nobody has asked me for any, and I would not have forwarded it to them.

Senator BYRD. So you are, indeed, saying that nobody in the Pentagon approved these rules.

General ABIZAID. I do not know that I am saying whether they reviewed them or not. I am saying that I have not personally forwarded anything to the Pentagon for their approval.

Senator BYRD. Did the SECDEF have to approve these rules to your knowledge?

General ABIZAID. Sir, I am just telling you what I said. In CENTCOM, I have not forwarded anything to the Pentagon for approval with regard to ROE.

Senator BYRD. I am not asking you what you forwarded to the Pentagon. To your knowledge, did the SECDEF have to approve these, or did he approve these ROE, to your knowledge?

Colonel WARREN. Senator, if I might, I was the legal advisor for the command and participated in the drafting of the counter-resistance and interrogation policy. There is no requirement that the DOD review or approve the methods that we used. As Generals Abizaid and Sanchez have said, they were operating in a combat environment. The commanders have the authority to approve those policies.

Senator BYRD. All right, if there is no requirement, to your knowledge, did the SECDEF approve these ROE?

Colonel WARREN. Sir, to my knowledge, no.

Senator BYRD. General Sanchez, as Senator Kennedy stated, The New York Times reported this morning—and here it is, right here—the headline says, “Officer Says Army Tried to Curb ICRC Visits to Prison in Iraq.” Is that allegation accurate?

General SANCHEZ. Sir, I never approved any policy or procedure or requirement to do that.

Senator BYRD. Let us see what this says. “Two announced inspections in Iraq,” and, “The ICRC observed abuses in one cell block on two unannounced inspections in October, and complained in writing on November 6. The military responded that inspectors should make appointments before visiting the cell block.” Well, we know what that means.

General Abizaid, the ICRC has alleged a pattern of abuse at detention centers in Iraq. With all due respect, how can you explain the culture of abuse that was allowed to develop in a prison system under your ultimate command?

General ABIZAID. I do not believe that a culture of abuse existed in my command. I do not believe that based on what my IG told me and what the Department of the Army IG told me. I believe that we have isolated incidents that have taken place. I am aware that the ICRC has its view on things. A lot of its view is based upon what happens at the point of detention where soldiers fighting for their lives detain people, which is a very brutal and bloody event.

Senator BYRD. Thank you, Mr. Chairman, my time is up.

Chairman WARNER. Thank you, Senator Byrd.

Senator Allard.

General ABIZAID. Mr. Chairman, if I may?

Chairman WARNER. Feel free, General, when you wish to add some information.

General ABIZAID. Policies do flow from the top of the DOD and I do not want to give any impression that they do not.

Chairman WARNER. We recognize the tradition of civilian leadership.

General ABIZAID. But SOPs are our business and we work them.

Senator BYRD. These are not SOPs we are talking about, I hope.

Chairman WARNER. Fine.

Senator Allard.

Senator ALLARD. Mr. Chairman, I just want to point out that I think the real travesty of justice is on the other side, where we see women and children used as shields, where we see a fight being carried on in mosques and other religious structures by our adversaries, where I see that conflict being carried in schools, and where our adversaries do not care about innocent lives. They will cheat and lie and do anything. I think that we have to understand the challenges that our men and women are facing in Iraq, and I think that it is a very difficult situation.

Now, that does not justify, I think, what we have seen by a few individuals here in this prison, and I want to fully understand how it is that that kind of incident would happen in the prison. I think we all have to understand it. I think, General Abizaid, that you have recognized that there is a problem and that we are in the process of correcting that problem.

Major General Miller, of the list of reports that came out, yours was the first report. You looked at Guantanamo and then you went on ahead and briefed, I think, the command in Iraq as to what you learned in Guantanamo, is that correct?

General MILLER. Senator, when I briefed the command of CJTF-7, it was on the findings and recommendations that the team I brought found of our assessment of the operations within CJTF-7 in Iraq.

Senator ALLARD. Did you share with them some of the lessons learned and what not in Guantanamo, and explain to them what to watch out for?

General MILLER. Yes, sir. We used our SOPs that we had developed for humane detention, interrogation, and intelligence fusion, to be able to use that as a starting point where they could go about improving their capability.

Senator ALLARD. So when you did your briefing, how far down did that information go? Did it go to those interrogators or were you relying on individuals further down in the command to pass on your words?

General MILLER. Sir, the recommendations that I made from the assessments were given to the senior leadership of the JTF for them to make decisions, upon their applicability, and then to, if they chose, make additional modifications to their procedures to go about doing that. In no case did the team have the opportunity to or ask to brief down at the lowest level. It was at the senior leadership level, at the commander and the senior staff-officer level.

Senator ALLARD. Now, with those lessons learned, can anybody on this panel explain to me what happened to the information that was shared by Major General Miller to the higher command? How was that passed down?

General SANCHEZ. Yes, Senator. After I received the recommendations of General Miller, I then forwarded those to my staff and the commander of the detention center for modification, in accordance with the Geneva Conventions, since we knew that there was a difference in climates between the two different operations.

Senator ALLARD. By that difference in climate, you are saying that, in Guantanamo, it was not as pertinent to actually what was happening in the field of battle, but what was happening in Iraq was very pertinent to what was happening on a day-to-day basis in the field of battle, and that information was crucial to the survival of Americans. Is that correct?

General SANCHEZ. Yes, sir, that is exactly right. We were, at that point in time, working very hard to get intelligence fusion at a higher level that could allow us to target, precisely, the enemy forces. We had to very rapidly take those recommendations and modify them to the theater, modify them to ensure that they were in accordance with the Geneva Conventions, get the lessons that had been learned before in interrogation and detention operations, and be able to adjust our own procedures and fix the procedures that we had in country.

Senator ALLARD. Now, General Abizaid and General Sanchez, I would like for you to describe the checks and balances, or the command-wide reporting and supervision, that was in place during 2003, when the subject prisoner abuses occurred. General Taguba's report clearly shows abuses reported as early as May 2003 in Iraq, as well as major accountability and leadership and basic discipline breakdowns through the 800th MP Brigade. I guess the bottom line is, did Brigadier General Karpinski, the 800th MP Brigade Commander, keep you informed as to the deteriorating conditions in her command?

General ABIZAID. I did not talk to the 800th MP Brigade Commander.

Senator ALLARD. General Sanchez.

General SANCHEZ. Sir, as far as the deteriorating conditions of her command, part of our basic understanding in the July/August time frame was that we had a detainee situation that had not been faced by our Army in over 50 years. That was the reason why I had requested the Ryder team to come in to assist us in establishing those operations so that they would be efficient, effective, and treating people with dignity and respect. That is why I supported the Miller team coming into the country. We were providing the resources that were necessary in order for us to stand up the capabilities of the 800th to be able to function effectively.

Senator ALLARD. So the Ryder Report, that was a first report in trying to deal with any hint of impropriety that was happening at the prison, is that correct?

General SANCHEZ. Senator, there were investigations that had been conducted as a result of allegations of abuse that were out in the command, not at the detention centers, at that point. As we have stated before, there were allegations at the point of contact, where the soldiers are fighting every single day, from the ICRC, that prisoners were being treated roughly. Those were the allegations that were being investigated at that point in time. As far as

detention center abuses at that point, I did not have knowledge of that.

General ABIZAID. But I would like to make sure that the committee understands we did have detention center problems. They were overcrowded, we didn't have the MPs in the right place, we were moving into facilities that had been destroyed or damaged by the war, and we had an intelligence problem, in that the tactical units were not getting feedback from the detainees who moved into the detention centers. From Ambassador Bremer's point of view, he had a problem, in that we were not releasing detainees back into the population quickly enough, and he wanted us to come up with a system that would make that more efficient.

So let us be clear that we understood there were problems in the detainee system, linked to the intelligence system, linked to the political system, that had to be addressed and we were working on them. But I would also like to remind you that these images are not the kind of thing that we thought was happening out there, that anyone in the chain of command would have condoned or allowed to be practiced.

Senator ALLARD. Mr. Chairman, my time is expired.

General MILLER. Sir, if I may just add one clarifying point, because I think it is important. During the assistance visit that my team made in the August/September time frame, we were also charged with the responsibility of looking for humane detention at the CJTF-7 level detention facilities. In doing that assessment in one of the facilities, the team found that it was being operated in an unsatisfactory manner. I stopped the assessment, went to General Sanchez and made this report. He directed that there be corrective action made within 48 hours in this facility. That action was immediately started and was continuing on as the assessment team that I led departed theater. So there were reports. I will tell you there was very aggressive action taken by the chain of command to go about correcting those shortfalls.

Senator ALLARD. Thank you, Mr. Chairman.

Chairman WARNER. Thank you, Senator.

Senator ALLARD. My time is expired.

Chairman WARNER. Thank you very much.

Senator Reed.

Senator REED. Thank you, Mr. Chairman.

Colonel Warren, is it accurate to say that all the prisoners at Abu Ghraib were entitled to the protections of the Geneva Conventions, that they were either enemy prisoners of war (POWs) or protected persons? Is that correct?

Colonel WARREN. Sir, that is right. They were protected persons, either under the Third or Fourth Geneva Conventions.

Senator REED. Under the Geneva Convention Article 31, no physical or moral coercion shall be exercised against any protected persons, in particular to obtain information about them or from third parties. Is that correct?

Colonel WARREN. Sir, you are quoting from Article 31 of the Fourth Convention. That is an accurate recitation of what the Article says. I would cite for you Pictet's Commentary on the Article for elaboration that coercion should not be taken out of context.

Senator REED. Colonel, thank you. But that is the operative rule.

Colonel WARREN. That is the literal rule.

Senator REED. Let us go back to the ROE here. Sleep management, 72 hours, sensory deprivation, 72 hours. Would you consider that to be physical or moral coercion?

Colonel WARREN. Sir, not prohibited coercion, under Article 31, for security internees and unlawful combatants.

Senator REED. I am talking about "in particular to obtain information about them or from third parties."

Colonel WARREN. No, sir, I would not.

Senator REED. So these are not methods to use for interrogation.

Colonel WARREN. Sir, the list on the right-hand side of the—

Senator REED. Can you answer the question, Colonel?

Colonel WARREN. Sir, that does not require a yes or no answer. I have to elaborate upon it.

Senator REED. Well, Colonel, my time is 6 minutes, so let me just move on.

Colonel WARREN. Yes, sir.

Senator REED. You have just said that these are coercive means.

Colonel WARREN. No, sir, I did not. What I said is—

Senator REED. For a protected person to obtain information.

Colonel WARREN. No, sir. What I said was those that are on the right are a list on a slide, which was produced at a low level, which was not representative of our counter-resistance and interrogation policy.

Senator REED. Excuse me, Colonel. I am not asking how it was evolved, but if 72 hours with a bag over your head is contrary to Article 31 of the Fourth Geneva Convention.

Colonel WARREN. That would be. Yes, sir.

Senator REED. Thank you.

General Sanchez, in today's USA Today, it has been reported that you ordered or approved the use of sleep deprivation, intimidation by guard dogs, excessive noise, and inducing fear as an interrogation method for a prisoner in Abu Ghraib prison. Is that correct?

General SANCHEZ. Sir, that may be correct that it is in a news article, but I never approved any of those measures to be used within the CJTF-7 at any time in the last year.

Senator REED. Excuse me. Now I want to get back to this. It may be correct that you ordered those methods used against a prisoner, is that your answer?

General SANCHEZ. No, sir, that is not what I said. I said it may be correct that it is printed in an article, but I have never approved the use of any of those methods within CJTF-7 in the 12½ months that I have been in Iraq.

Senator REED. What level of command produced this slide?

General SANCHEZ. Sir, my understanding is that that was produced at the company commander level.

[The information referred to follows:]

In response to questions by Senator Reed concerning whether I had ordered or approved specific interrogation approaches, I stated, "I have never approved the use of any of those methods within CJTF-7 in the 12.5 months that I've been in Iraq." I provided a similar response to follow-up questions by Senators Collins and Dayton.

In the context of Senator Reed's questions, "those methods" referred to a list of interrogation approaches on the right column of a chart entitled, "Interrogation Rules of Engagement" (IROE), which would require a written exception to policy for

use, and to "Sleep Deprivation, Intimidation by Guard Dogs, Excessive Noise and Inducing Fear," which were reported in a USA Today article as having been approved by me for a specific prisoner at Abu Ghraib prison.

CJTF-7 Interrogation and Counter-Resistance Policy in the fall of 2003 was stated in two memoranda, the first dated September 14, 2003, and the second dated October 12, 2003. Both CJTF-7 Interrogation and Counter-Resistance Policy memoranda were furnished to the committee on May 19. The September 14 Policy authorized the methods listed in the right column of the IROE chart, except for "sensory deprivation" and "sleep deprivation." Use of the authorized methods was subject to the general and specific safeguards listed in Enclosure 2 of the Policy, as well as the implementation guidance of the commander, 205th MI Brigade. The September Policy remained in effect for less than 1 month, until superseded by the October 12 Policy.

The October 12 Policy, which remained in effect for 7 months, authorizes the methods listed at its Enclosure 1. These methods do not include sleep deprivation, presence of military working dogs, or excessive noise. Use of any methods not listed at Enclosure 1 of the October 12 memorandum would require an exception to policy granted by me, as well as legal review and review by the command's senior intelligence officer. The methods listed in the right column of the IROE chart are similarly not authorized under the October 12 Policy without an exception to policy granted by me.

Except for segregation in excess of 30 days, I have neither received nor approved any requests for the use of any methods requiring an exception to policy. Except for segregation in excess of 30 days, I have not approved the use of any of those methods for a particular prisoner.

Senator REED. How could the company commander evolve such a specific list? How could the company commander then turn around and say some of these things would require your permission, without any interaction between your commands? It seems to me just difficult to understand.

General SANCHEZ. Sir, it is difficult for me to understand. You would have to ask the commander.

Senator REED. This is the company commander that you relieved and gave a letter of admonition?

General SANCHEZ. No, sir.

Senator REED. No? Okay.

General Miller, at Guantanamo it has been reported that you developed a 72-point matrix for stress and duress that lays out types of coercion and escalating levels. They include harsh heat or cold, withholding food, hooding for days at a time, and naked isolation in cold, dark cells. Is that correct?

General MILLER. Sir, that is categorically incorrect.

Senator REED. That never happened.

General MILLER. Sir, that is categorically incorrect.

Senator REED. All right. When you were dispatched by Secretary Cambone and General Boykin to go to Iraq, did they give you any specific instructions about increasing the aggressiveness of interrogations?

General MILLER. Sir, I was tasked to conduct an assistance visit by the Joint Chiefs of Staff. They tasked U.S. Southern Command (SOUTHCOM), who then tasked CJTF-Guantanamo to put the team together.

Senator REED. Did you have conversations with General Boykin and Secretary Cambone, prior to your departure, about your trip?

General MILLER. Sir, I did not.

Senator REED. You did not. Did you have any discussions after your visit, after you returned?

General MILLER. Sir, I submitted the report up to SOUTHCOM. I had no direct discussions with Secretary Cambone or General Boykin.

Senator REED. Well, Secretary Cambone testified that General Boykin briefed him on your discussions, and he led to the implication that you and General Boykin had—have you spoken to General Boykin about any of these issues?

General MILLER. No, sir. The report was provided up, and this is my speculation, because I do not know—it may have gone to General Boykin, but he and I have not had personal conversations about this inspection visit.

Senator REED. Your team, when they went down and briefed at the—how low a level did you brief and talk to the people in that prison?

General MILLER. Yes, sir. Sir, that team went at several different levels. They started at the CJTF level.

Senator REED. How far did they go in the prison?

General MILLER. Then went down to the battalion commander level at the MP function, and to the company commander level at the MI function.

Senator REED. That might be the level where this document was developed?

General MILLER. Sir, I do not know what level that document was developed at.

Senator REED. Did your team specifically brief that these techniques, which you deny being in place in Guantanamo, could not be used? Did they in any way suggest that methods could be used in that prison that are contrary to the Geneva Conventions?

General MILLER. Sir, no methods contrary to the Geneva Conventions were presented at any time by the assistance team that I took to CJTF-7. There is no—because you brought it up again, sir—there is no status, or there is no program at JTF-Guantanamo that has any of those techniques that are that are prohibited by the Geneva Conventions.

Senator REED. One of the problems we have, General, is that we have not yet, after repeated requests, received that documentation about the interrogation techniques at Guantanamo, which is another lack of cooperation in this investigation.

My time has expired. Will we have a second round, Mr. Chairman?

Chairman WARNER. It is important that we conclude today's round with a closed session, and Senators will be given an opportunity to ask questions.

Senator Sessions.

Senator SESSIONS. Thank you, Mr. Chairman. I thank all of you for your service in a difficult and dangerous area of the world. You are serving your country with distinction.

General Abizaid, I appreciate your leadership and your comments earlier today. We have made progress in Afghanistan and Iraq. We have had al Qaeda on the run and we have avoided another attack on this country, for which we can be grateful. I think you are correct to suggest that sometimes in this city, people get preoccupied with failure and error, rather than seeing the progress that has occurred.

I am troubled by this suggestion that the interrogation rules are some sort of a smoking gun of illegality and impropriety. You have been asked about sleep adjustment, or sleep management, for 72 hours. Those, as I read this document—this is a restrictive document that says such an action must have the direct approval of the commanding general. Is that the way you understand it, General Sanchez?

General SANCHEZ. Sir, that is the way I read that document also.

Senator SESSIONS. Are you the commanding general, or who was the commanding general referred to?

General SANCHEZ. That referred to the commanding general of CJTF-7. That is me, sir.

Senator SESSIONS. So the system was set up to restrict these kind of activities. They could never be done, even though, as Colonel Warren, the JAG officer, said, they could be acceptable under—some of them, at least—the Geneva Conventions, but they had to make a written report and request to you before any of those could be used.

General SANCHEZ. That is exactly right, sir.

Senator SESSIONS. Were any of these ever approved by you?

General SANCHEZ. Sir, the only approvals that I ever had at my desk were for continued segregation beyond 30 days, and there were 25 of those that were approved. I never saw any other method come to my level requesting approval.

Senator SESSIONS. So the only requests under this category of what some referred to as “harsher treatment” were the isolation requests, which is done in American prisons every day. These isolation requests were, in fact, submitted to you in writing. Did you or your staff make an evaluation before you approved them?

General SANCHEZ. Yes, sir. Those came forward. My staff, both the intelligence officer and my staff judge advocate, evaluated those, and then my staff judge advocate brought them in to me, and I personally approved them.

Senator SESSIONS. I would like to note that, in big print here, it says, “Safeguards. Approaches must always be humane and lawful. Detainees will NEVER”—in capital letters—“be touched in a malicious or unwanted manner.” Were the actions in this prison in violation of that directive? The allegations and the pictures we have seen, those would be in violation of that directive, would they not?

General SANCHEZ. Sir, if those allegations are proved in the investigative process to be true, those would be violations.

Senator SESSIONS. It says, “Geneva Conventions must be complied with.”

General SANCHEZ. Absolutely, sir. That was always the standard.

Senator SESSIONS. Now, General Abizaid or General Sanchez, General Ryder was a provost marshal. That is the person in charge of the military prison system, is that not correct?

General ABIZAID. Yes, sir, that is correct.

Senator SESSIONS. He is the Army’s top expert on how to house prisoners. It is not easy in the United States, I am telling you. Senator Kennedy and I sponsored a bill recently to crack down on sexual abuse in prisons, the prison rape bill, because it happens in American prisons, we have abuses. But it is difficult in a theater

of combat operations. You brought him over to help you bring order to this situation in the post-hostility conflict, is that what you did?

General ABIZAID. Yes, sir. We have asked for a lot of help, because we needed a lot of help in this theater on a lot of different things. But what is the most helpful is where commanders travel and look and see with their own eyes what is going on and how it is going on. General Sanchez and I and others have been all around the theater, have talked to interrogators, we have looked to make sure what was happening was right, and we emphasized to them, all the time, that they need to treat people right.

Senator SESSIONS. Well, things go awry. There is just no doubt about it. It is more difficult in a combat environment.

General Miller, you had a reputation for being able to manage a prison and to obtain information from detainees in a way that was closely inspected and observed by the ICRC and other people on a continuing basis. We had soldiers at risk in Iraq. We have civilian leadership of the new Iraqi Government at risk of their very lives, as we saw one just killed recently. It certainly would have been wonderful if we had obtained intelligence so we could have interdicted the latest murder of the head of the Iraqi Governing Council (IGC).

General Abizaid, you said you want to get information to the tactical commanders. For the American people who may not understand this language, part of the problem was, as I understood it, you were obtaining information, but were not getting it out to the people who could benefit from having it, is that fair to say?

General ABIZAID. Well, Senator, as I traveled around—and I spent most of my time when I go around going to tactical units—I was extremely impressed by the amount of information that they had about local conditions. I would always ask them whether, once the detainees were evacuated into the prison system, they receive follow-up information that would help them in their difficult job of breaking down the cellular structures that the enemy uses against us. At the same time, General Sanchez and I, probably very early on in General Sanchez's arriving in the theater, were concerned that we were not getting a good view of what was happening at the leadership level. So we knew that there had to be a connection between what the tactical units knew and what the leadership knew if we were ever to get at the insurgency-based problems that we were seeing out there. So we were dealing with a systemic problem, and we still do not have as good a view as we would like to have about the nature of the insurgency, and who is in charge, and where the cells move, and how they operate, et cetera. It is an intelligence-intensive task.

Senator SESSIONS. General Miller, one of your responsibilities was trying to make sure that the evidence that had been gathered was promptly disseminated. Is that one of your responsibilities?

General MILLER. That is correct, Senator.

Senator SESSIONS. I think my time has expired, Mr. Chairman.

Chairman WARNER. Thank you very much, Senator.

Senator Ben Nelson.

Senator BEN NELSON. Thank you, Mr. Chairman, and thank you all for being here this morning.

General Abizaid, I want to commend you, particularly for your candor. This city, and this group, from time to time, is used to what I have termed "progressive candor." We learn a little bit at a time, and ultimately somebody has to take responsibility. I appreciate very much your willingness to take the responsibility.

General Miller, there are photos showing MI, MPs, and private contractors in the vicinity of prisoner abuse. We are being told that it was a handful, or a few—the operative word of the day—bad apples engaging in activities that were abusive, not consistent with either Geneva Conventions rules or with the expectations of the command above them. So can you tell me who were the participants, who were the abusers in this situation? I am not aware of anyone outside of a handful of privates, sergeants, et cetera, being charged with anything. What about the private contractors? Are the MI people, apart from MPs, being charged, or do you know?

General MILLER. Senator, those events are a part of the investigations being done, also being done now by General Fay, involving the intelligence elements, both the military and any of the contractors who would be involved in the intelligence function.

Senator BEN NELSON. Will we expect something within a timely manner on those investigations?

General MILLER. Sir, it is my understanding that General Fay's report is nearing a close and that those reports will be given to the chain of command very quickly.

Senator BEN NELSON. General Miller, what instructions or orders were you given before you arrived on your way to Guantanamo?

General MILLER. Sir, on my assumption as the commander of JTF-Guantanamo, I went to the headquarters, SOUTHCOM, and General Hill laid out his responsibilities for me and gave me the orders. We had an opportunity to fuse two JTFs together that were not working as successfully. That was the priority mission, to be able to integrate both a detention and intelligence function to produce actionable intelligence for the Nation—in this case, operational and strategic intelligence to help us win the global war on terror.

Senator BEN NELSON. Did you talk to any of the civilians within the DOD?

General MILLER. Sir, initially I did not. Once I made my assessment at JTF-Guantanamo, then I went to Washington, DC, and talked to both the Intelligence Community and others who are a part of the functionalities that we had at Guantanamo about detention, interrogation, and an intelligence fusion.

Senator BEN NELSON. Anyone at the level of Under Secretary or Assistant Secretary of Defense?

General MILLER. Sir, I did not initially talk to them. But later on—as you remember, I was there for 17 months—I talked all the way up to the SECDEF level, briefing them on the operations that we had and the intelligence that we gathered and then the integration of those operations throughout Guantanamo.

Senator BEN NELSON. Were any of those discussions directed at what you might do in the future if you were assigned to Abu Ghraib, or to Iraq in general?

General MILLER. No, sir, they were not.

Senator BEN NELSON. Were there any differences between the two assignments?

General MILLER. Senator, there were substantial differences. JTF-Guantanamo has the responsibility to detain enemy combatants not covered by the Geneva Conventions, and so there were specific authorizations and limits that went directly into Guantanamo. So I became very knowledgeable of those. I read the Geneva Conventions, to be frank with you, in great depth. My lawyer probably spent 1 to 2 hours a day with me as I learned every day how to be more effective in doing this job and also doing it to the standards of America, using humane detention and interrogation that reflected America's values.

Senator BEN NELSON. Thank you.

General Sanchez, you suspended the entire chain of command that was under the command of General Karpinski, including General Karpinski herself. She says she objected to the interference with her command, which was represented by Colonel Pappas, in bringing intelligence operations and TACON over the prison. But you disagree that she objected.

General SANCHEZ. Senator, General Karpinski never talked to me about any interference.

Senator BEN NELSON. Did she send you a written communication?

General SANCHEZ. Sir, she received the same order that assigned responsibility for FOB protection and security of detainees as the other commanders in the task force.

Senator BEN NELSON. Is it usual that an MI officer would take over the tactical command for force protection?

General SANCHEZ. Sir, it is dependent upon the senior commander in that FOB who has responsibility to defend his soldiers.

Senator BEN NELSON. Do you know of any other instances?

General SANCHEZ. A brigade commander, yes, sir. The MI brigade commander, no, sir. He was a senior man who was permanently on that FOB, and he had responsibilities for protecting his soldiers, and that was my intent.

Senator BEN NELSON. Merging interrogation and force protection together?

General SANCHEZ. Sir, a commander has integral responsibility, independent of his mission, to protect his soldiers, and that was what I was trying to institutionalize.

Senator BEN NELSON. My time has expired. Thank you.

Chairman WARNER. Thank you very much, Senator.

Senator Collins.

Senator COLLINS. Thank you, Mr. Chairman.

First, let me begin by thanking all of you for your extraordinary service. One of the tragedies of this abuse scandal is that it not only obscures the fine work that you are doing, but it also overwhelms the thousands of acts of kindness, courage, and compassion by our troops every day in Iraq, and that is why this abuse scandal is particularly upsetting. I feel it sets back and undermines the good work of the vast majority of our troops.

I have to say that after reading the Taguba Report, reviewing the various interviews, and participating in these hearings, I remain unclear about the answers to some very basic and critical

questions, questions such as, who really was in charge of the prison, and what was allowed in the treatment of the prisoners?

General Sanchez, at the committee's hearing last week, General Alexander referred to these guidelines, the interrogation ROE, as yours. Numerous press reports have referred to these rules as "the Sanchez guidelines." But is it your testimony this morning that these guidelines were not issued by your office and that, in fact, you only saw them last week at our hearings?

General SANCHEZ. Ma'am, absolutely not. The first time I saw the slide that was specifically shown to me by one of the Senators, that is what I was referring to. I personally issued the memorandums, and I have both memorandums sitting here that I will provide to the committee.

[The information referred to follows:]

The requested documents were provided to the committee at the conclusion of the hearing on May 19, 2004, and as part of QFR number 76 for Lieutenant General Sanchez.

General SANCHEZ. Those ROEs were my ROEs, and I personally approved those after I consulted with my higher headquarters and my staff judge advocate.

Senator COLLINS. In response to a question from Senator Reed, you said, however, that you had never approved the presence of dogs, sleep deprivation, or stress positions that are listed on these guidelines. Is that correct?

General SANCHEZ. Ma'am, that is exactly right.

Senator COLLINS. General Sanchez, I also want to follow up on your November order putting MI in charge of some aspects of the prison. I also want to explore with you the role of MI, in general.

In the Taguba Report, the General says that the recommendation of General Miller's team, that the guard force be actively engaged in setting the conditions for the successful exploitation of the detainees, would appear to be in conflict with the recommendations of General Ryder's team and AR 190-8, that MPs do not participate in MI-supervised interrogation sessions. He also says that having MPs actively set the favorable conditions for interviews runs counter to the smooth operation of a detention facility. Didn't your order, where you involved the MPs in some aspects of the supervision of the prison, run counter to the regulation cited by General Taguba?

General ABIZAID. Senator Collins, may I address this?

Senator COLLINS. Yes, General.

General ABIZAID. First of all, we do not have all the facts. I think it is important for the committee to understand that. We need to see what we are going to hear from the 205th MI Brigade. What was in the mind of that commander? What did he think?

So if we can set that aside, let me share with you one of the findings that came out of the Department of the Army IG investigations but are preliminary. They are not approved. I am sure they will be shared with this committee. Our doctrine is not right. It is just not right. There are so many things that are out there that are not right in the way that we operate for this war. This is a doctrinal problem of understanding where you bring—what do the MPs do? What do the MI guys do? How do they come together in the right way? This doctrinal issue has to be fixed if we are ever

going to get our intelligence right to fight this war and beat this enemy. So we have problems that have to be looked at from top to bottom in order to ensure that there is no confusion. Because, you see, the Ryder Report says one thing, the Taguba Report will say one thing.

Senator COLLINS. Exactly my point.

General ABIZAD. You are going to see that the Fay Report says something else. It is not because anybody is lying to anybody; it is because the system is not right. There are a lot of systems that are wrong out there that we had better fix if we are going to beat this enemy.

Senator COLLINS. But, General, I guess what concerns me is, when you have all these contradictory doctrines or all these contradictory findings, it suggests to me that there was great confusion at the prison, and that confusion can set the stage for the kinds of unacceptable abuses that occurred. That is my concern.

General ABIZAD. It is a concern that I share, Senator, and we will find out the facts. But I would like to ensure that you understand that there is great confusion in a combat zone all the time—almost as much as there is here in Washington, but not quite.

Senator COLLINS. Thank you, General.

Chairman WARNER. Thank you, Senator.

That confusion in the combat zone goes way back in history.

Senator DAYTON.

Senator DAYTON. Thank you, Mr. Chairman. I wanted to join with others in thanking you for convening this hearing and doing your utmost to get to the bottom of these matters.

But I really question our ability to get down to the truth of what has occurred at 6 minutes apiece. We now have heard from 15 of the highest-level officials involved in this entire operation, from the SECDEF to the generals in command, and nobody knew that anything was amiss, no one approved anything amiss, no one did anything amiss. We have a general acceptance of responsibility, but there is no one to blame, except for the people down at the very bottom of one prison. The focus has been on that, although the ICRC report says that there were abuses at 14 different prisons under U.S. control.

According to The New York Times today, the ICRC complained in writing on November 6 about some of the abuses that they had witnessed, which paralleled the practices that were shown in the pictures, of holding Iraqi prisoners naked in dark concrete cells for several days at a time, forcing them to wear women's underwear on their heads while being paraded and photographed, and it characterizes the response of the Army to that complaint as barring unannounced visits by the ICRC at the prisons. It cited a particular letter dated December 24 that the Army had described as evidence of the military promptly addressing the ICRC concerns, but the action that was taken, the barring of unannounced visits, brings into question what the content of that letter actually was.

The Army has refused to release that letter, citing "a tradition of confidentiality in dealing with the international agency." An Army spokesman declined on Tuesday to characterize the letter or to discuss what it said about the ICRC's access to the cell block.

General Sanchez, is that evidence of the transparency of this Army's handling of these matters? How are we going to find anything out if no one will tell us anything or even provide the information that is necessary to evaluate these matters?

General SANCHEZ. Senator, I swore to tell you the truth, and everything that I have told you in here is the truth.

Senator DAYTON. What is in the December 24 letter to the ICRC?

General SANCHEZ. Sir, I do not recall exactly what the—we have the letter, obviously, and I would have to leave it to the Department to provide that letter to you, sir. Sir, as far as I am concerned, we are transparent within CJTF-7.

Senator DAYTON. All right, I will accept that, then. So you will provide a copy of that letter, and we can assess what the response was?

General SANCHEZ. Sir, as long as that is within the approval of the higher headquarters and the DOD, yes, sir, we will provide that.

[The information referred to follows:]

The requested document was provided as an attachment to the Lieutenant General Sanchez QFR number 35.

Senator DAYTON. All right. That is a big caveat, but we will see what comes forward.

General SANCHEZ. Sir, I have no problems with providing you that letter; however, there are higher-headquarters directives.

Senator DAYTON. Fair enough.

Sir, on November 19, you—again, according to another newspaper report; sometimes I think our responsibilities in this body are relegated to reading the newspapers and watching the other news reports to find out these things that we are not getting any information about—but there is reportedly a memo from your office, General Sanchez, on November 19, that placed the two key Abu Ghraib cell blocks, where the abuses occurred, under the control of Colonel Pappas. Then there is also reference made to a request he reportedly made to you 11 days later about a interrogation plan for a particular prisoner that involved—first, the interrogators were to throw chairs and tables in the man's presence at the prison and “invade his personal space.” This is a request from Colonel Pappas, the man to whom you turned over that authority over those two cells. Then the police were to put a hood on his head and take him to an isolated cell through a gauntlet of barking dogs. There, the police were to strip-search him and interrupt his sleep for 3 days, with interrogations, barking, and loud music, according to Army documents, the plan that was sent to you. Is that one of the 25 requests for additional interrogation techniques that you approved?

General SANCHEZ. Sir, first of all, you stated that I issued an order that I specifically put key cell blocks under Colonel Pappas. I never issued such an order. Second—

Senator DAYTON. Okay. So the article is incorrect?

General SANCHEZ. Sir, I never issued such an order.

Second, that request never made it to my headquarters—or to me, personally, rather.

Senator DAYTON. So there was not any memo on November 19 from your office to place these cell blocks under Colonel Pappas?

General SANCHEZ. No, sir. I never issued such an order.

Senator DAYTON. All right.

General SANCHEZ. That specific request for interrogation methods, that never got the CJTF-7 commanding general's level, and I never approved any interrogation methods other than continued segregation.

Senator DAYTON. Thank you.

General Abizaid, you commented on the need to stay the course. Speaking for myself—I will not presume to speak for my colleagues—the Senate has been bipartisanly resolute behind every request the President has made for funding and support. It has been virtually unanimous. It has been across the board—the supplemental appropriations, the authorizations we are taking up now, the 2005 authorization. We are adding, at the request of the President, an additional \$25 billion for purposes that have not even been defined. But I think it is something I wanted to try to get an answer on from various authorities. What is that course? What is the direction that we are on? I would just note in response particularly to some comments that were made about how well things are going, I do not know how to sort this out. I want us to succeed there. I just want to be told the truth about whether we are doing well or not, so we can assess whether the Minnesotans and other Americans who are serving over there are going to be there for months or years, and what their likelihood is of returning safely and alive.

But I refer here to a Washington Post comment made by a Kurdish member of the IGC, that if something is not done about the security situation, there will be no transfer of power. “Uthman”—his name—“who is generally pro-American, described the assassination as only the most extreme example of the lawlessness that has grown in the year since President Saddam Hussein was driven from power. ‘Never in Iraq has it been like this. Never. Even under Saddam,’ he said. ‘People are killed, kidnapped, and assaulted, children are taken away, women are raped, no one is afraid of any punishment.’” Is that an accurate description of 1 percent of the country, 5 percent, more than that? What is the security situation there, sir?

General ABIZAID. Yes, sir. I appreciate the question. First of all, not only were people carried away in the middle of the night and raped and tortured and killed under Saddam, but it happened at a huge scale, at an institutional scale unequaled in any recent memory, perhaps only rivaled by what the Nazis did. So, are things better just by the mere fact that that regime of torture and intimidation is gone? Yes, that is a good thing.

On the other hand, I will not be Pollyannaish about where we are, Senator. This is a hard thing, and it is going to take a long time, and it is going to take a lot of courage and a lot of perseverance and, unfortunately, more blood, and it is going to take more treasure. But there are more people in Iraq that are working with us to try to make their country a better place than are trying to tear it apart. The people that are trying to tear it apart are ruthless. They are doing it precisely now for the reasons that—I think I have been about as honest as I could be with this committee in the past—because this is the vulnerable time. They must make it

fail now. They are pulling out everything that they can to make it fail. It is hard. That is why we kept extra forces there. It is hard, and it is tough, and it is difficult. But we will prevail. I am telling you, there are things that are bad about Iraq, and we are responsible for security, and it is not like walking in downtown Washington, DC. It is a dangerous place. But I can tell you, people have a right to express their opinion. There is political activity, there is freedom of the press, there are things that are happening in Iraq that do not happen anywhere else in the Middle East, and we ought to be damn proud about it.

Senator DAYTON. May I just conclude? My time is up. How soon do you expect that the 200 or 4,000 or whatever Iraqi police and militia will be in a position to enforce their own law and order on their city streets?

General ABIZAIID. Well, Senator, I would have said, before the recent events, that somewhere between September and December they would be ready, but we had a setback. We know we had a setback, and we are putting one of our best officers in the United States military on the job. If the creek does not rise, somewhere between January and April they will be ready.

Senator DAYTON. Thank you, Mr. Chairman.

Chairman WARNER. Thank you very much, Senator.

Senator Chambliss.

Senator CHAMBLISS. Thank you, Mr. Chairman.

Gentlemen, let me echo the sentiments of all of our colleagues up here relative to the leadership you are providing and the great job that all the men and women underneath you are doing. While we have seen this story on the front pages of the paper for the last 3 weeks, those of us who have followed the details of the battles that your men and women are waging every day know and understand that you have scored major victory after major victory in the last 3 weeks, and we commend you for the great job your folks are doing.

Colonel Warren, would you tell me what the jurisdiction is between the Central Intelligence Agency (CIA) and the Army relative to the arresting, securing, transporting, and interrogation of these detainees in Iraq?

Colonel WARREN. Sir, I do not know that it is a matter, necessarily, of jurisdiction. We do know that other agencies do detain individuals in Iraq. They use the same legal standard under the Fourth Geneva Convention, which is that they are imperative threats to security. Once they are brought into a coalition force's detention facility, they are subject to our rules and regulations.

Senator CHAMBLISS. Well, is there any integration or cooperation between the CIA and the Army relative to the securing of prisoners and bringing them to places like Abu Ghraib?

Colonel WARREN. Sir, your question is outside the scope of my knowledge. I can speak to the rules that apply once they are inducted; the arrangements relative to operations, I am unable to speak to those.

Senator CHAMBLISS. General Abizaid, can you answer that question?

General ABIZAIID. Sir, I would like to answer the question in closed session.

Senator CHAMBLISS. Okay.

General Abizaid and General Sanchez, I have asked this question twice before, and I still have not gotten a satisfactory answer. General Ryder was sent to this prison. He was there in late October, early November 2003. During the very time he was there, these particular incidences that are alleged, the alleged abuses that we are talking about now, were ongoing. Yet even though he was asking questions of the conditions of the prison and the condition of the prisoners, nobody told him, apparently, one word about these incidences happening. Can either of you give me any explanation of why that would have happened when a general of his stature was there?

General ABIZAID. Well, I can tell you that as I travel around, I do not always get the whole truth and nothing but the truth. I get a lot of, "Everything is okay, everything is fine, do not worry about it." That is one of the problems that we have in the Armed Forces, that we have to look beyond our rank and think about what would our son be doing in that particular position in that particular unit, and is he or your daughter doing the right thing or not. So just because General Ryder was there, because General Sanchez was there, because half a dozen other important people that went there to visit it did not see it does not mean it was not happening. We have a lot to understand about what went on in that organization, and why and who was responsible.

Senator CHAMBLISS. Well, I accept your answer. I think it is a repeat of the statement you made earlier that there are some things in this system that are broken, and you are now working to fix them. That is what leadership is all about; when you recognize a problem, you take after it, and you fix it. I commend you for doing that.

General Miller, the situation at Guantanamo has been alluded to by a number of folks during this process. I have been down there a couple of times. I had the opportunity to visit the prison, both before the new camp was built as well as afterwards, and I saw the interrogation of prisoners down there. From what I saw, and from what I have heard, there has been no systemic prisoner abuse that was ongoing at any point in time at Guantanamo, and I just wish you would address that very quickly, if you will, please.

General MILLER. Thank you, Senator. Sir, there was no systemic abuse of prisoners at Guantanamo at any time. I believe that there were three or four events—I will have to correct that for the record as we go back and look—of instances of minor abuse.

[The information referred to follows:]

There were a total of eight instances of minor abuse requiring administrative action. Those infractions resulted in one reassignment, one counseling, three reprimands, two Article 15s, and one Special Court Martial acquittal.

Two or three of those were corrected by administrative action, an Article 15, and one went to court-martial about an abuse of one of the enemy combatants down there. It was the effect of strong, dynamic leadership by the chain of command 24 hours a day, 7 days a week, that did not allow the abuse to happen. We walked the cell blocks and the interrogation booths of Guantanamo around the clock—not because we did not trust our people, but this is a very difficult mission, and it takes active engagement by leadership to

ensure that it is done correctly. That is why, in Guantanamo, because of the enormously talented people who were there—75 percent, as most of you know, were Reserve component leaders—we were successful.

Senator CHAMBLISS. Thank you.

Colonel Warren, there is an article in The Wall Street Journal today, which says, “A senior legal advisor to Lieutenant General Sanchez helped draft a formal response to the Red Cross’s November report, according to one senior Army official.” Is that you they are referring to?

Colonel WARREN. Sir, that may be me to whom they are referring. In fact, I did not draft that particular response. I believe, however, that my office did. As General Sanchez alluded to earlier, before January the intake of working papers—the camp visit reports from the ICRC—were handled in a haphazard manner. Some of them were given to the camp commander, some were given to the MP brigade, some went to my office. In the particular case that is at issue, the October visit, it took a period of time—and I do not know how long, but I believe several weeks—for the working papers to reach the level of my office. My office participated in the drafting of a response for Brigadier General Karpinski’s signature. That response was dated December 24, and would have been delivered to the ICRC.

When we discovered this haphazard process—and, frankly, were concerned in the December time frame, when I first became aware of the content of the report and its genesis—I talked to General Sanchez. This would have been in early January. General Sanchez then mandated that, from that point forward, all ICRC reports and working papers would be addressed to him, and that the single entry point for those to the command would be me. That way we could maintain positive accountability of those reports, as well as take remediative action and track the corrections that were done by the subordinate commands.

Senator CHAMBLISS. Thank you.

Thank you, gentlemen.

Chairman WARNER. Thank you very much, Senator.

Senator Clinton.

Senator CLINTON. Thank you, Mr. Chairman.

I thank our witnesses for their service and for their appearance today. I know it is not an easy assignment to be here, given, especially, all your other responsibilities. But it is in line with this committee’s constitutional and institutional responsibilities, and I believe all of us are trying to discharge them to the best of our ability.

General Miller, I would like to return for a moment to this Interrogation ROE document that has been much discussed. General Sanchez characterized this document as having been developed at a relatively low level, at the company level, and indicated that he had not seen it before it became public at our hearings. But in an annex to the Taguba Report, it was revealed that this document was briefed to you as part of a situation report when you visited Iraq in August 2003. What was your reaction to that document at that time? Did you have any concern that the techniques described would violate the Geneva Conventions?

General MILLER. Senator, that report is incorrect. At no time was that document briefed to me during my visit in the August/September time frame.

Senator CLINTON. Was it briefed to you at any time prior to that or following that period?

General MILLER. Senator, that document was never briefed to me at any time.

Senator CLINTON. Were the contents of the document briefed to you, General?

General MILLER. The contents of that document were not briefed to me.

Senator CLINTON. So it is not only that you never saw the document, the slide; you were never briefed, orally or in writing, about the contents of that document. Is that correct?

General MILLER. Senator, that is absolutely correct.

Senator CLINTON. General Sanchez, at a hearing last week, General Alexander, the head of Army MI, distributed that slide to the committee. He stated, at that time, that the slide was prepared by CJTF staff, your staff. Do you know where General Alexander obtained the slide or why he believed that this came from your staff?

General SANCHEZ. No, ma'am, I do not.

Senator CLINTON. Colonel Warren, do you have any information that would lend us some additional enlightenment about why General Alexander told us, in sworn testimony, that this slide came from General Sanchez' staff?

Colonel WARREN. I absolutely do, ma'am. The reason that the General made the statement that he did is because the slide, as we now know, contained a CJTF-7 logo and was posted on the wall of the Joint Interrogation and Debriefing Center at Abu Ghraib. It was titled "The Interrogation Rules of Engagement," an unfortunate use of the term "ROE. What it should have said is, "Interrogation Policy Extract." That is the context that is so vital for you to understand, ma'am. When that slide was created—and I talked to the person who created it; it was the commander of Alpha Company 519th MI Battalion—

Senator CLINTON. What was that person's name, Colonel?

Colonel WARREN. Captain Woods, ma'am.

Senator CLINTON. Thank you.

Colonel WARREN. It was intended to be a prophylaxis. There is really nothing insidious about that particular slide. In fact, if you will go back, ma'am, to the Counter-Resistance and Interrogation Policies, which General Sanchez has said we will make available to the committee, you will see that they lay out specific measures that are approved.

The October 12 memorandum, in fact, approves only those measures which are contained within the Army Field Manual on interrogations that applies to POWs and segregation in excess of 30 days. The intent of the slide, however, was to ensure that interrogators understood that those measures on the left-hand column—the ones that were approved, the ones I mentioned—were authorized, but that any other measures were not, without commanding-general approval.

Now, why is it that some of those, again, that seem to be the so-called "harsh methods" appear on the right, ones such as sensory

deprivation that were never in any authorized policy? The reason is that within the drafts that we prepared in the headquarters in the September and October time frame, we, collectively—the legal community and the MI community—took every doctrinal approach that was authorized, we took every approach that had been used by interrogators in other places, we took every approach that was contained in any document that we could find, and we put that in a policy so as to regulate it to ensure that it complied with the Geneva Conventions, that there was command oversight, there was a specific safeguards document that was published that referenced the Conventions, and required that at no time could any interrogator in any approach violate the floor of the Geneva Conventions—that is, the basic requirements to food, shelter, water, medical care, clothing, and protection. It required an interrogation plan. It required that any exception to policy go through the senior intelligence officer and the staff judge advocate, me, before going to the commanding general.

So the intent of that slide was to remind interrogators that anything that was not authorized had to go to the commanding general. By the way, that list was prepared by a captain with all good intentions, but it had items on it that could never be approved, and frankly, could never reasonably be requested.

But note, ma'am, what is on the bottom. That is something that often is overlooked, because that captain did not do a bad job. That captain paraphrased the safeguards that are in enclosure two of our Counter-Resistance and Interrogation Policy. You will note that they talk about the requirement to treat everyone with humanity, to follow the Geneva Conventions, and to never unlawfully touch a person who is under interrogation.

Senator CLINTON. Colonel, may I just quickly follow up in one question. Are you aware of any requests for approval submitted in writing for any exceptions to the list on the right-hand side?

Colonel WARREN. Yes, ma'am. I am aware of approximately 25 requests for segregation in excess of 30 days, which went through the process of approval that I described. I am also aware that there were three requests for stress positions which were submitted and were denied at the brigade commander level, so they never would have arisen to the CJTF-7 level for review or approval.

Senator CLINTON. Is it also your understanding that non-military agents of our government and private contractors were similarly bound by the rules that you have just described?

Colonel WARREN. Ma'am, I can not speak definitively to the former. However, I can speak definitively to the latter, and any contractors who were working within our facility under contract to the DOD were certainly and clearly bound by our rules and policies.

Chairman WARNER. Thank you very much, Senator.

Senator Graham.

Senator GRAHAM. Thank you, Mr. Chairman.

General Abizaid, is it fair to say that people in the region, the Arab world, are watching these hearings, and have been?

General ABIZAID. It is fair to say that, Senator, yes, sir.

Senator GRAHAM. In your professional opinion—I know we are sort of beating on ourselves here a bit—does this help or hurt our cause?

General ABIZAIID. It helps our cause.

Senator GRAHAM. I could not agree with you more.

General ABIZAIID. It helps our cause, because they have to know that people will be held accountable who are in positions of responsibility.

Senator GRAHAM. Does anybody at this panel feel like a burden has been placed upon you to come here and have to talk about what happened?

General ABIZAIID. No, sir. We feel it is our responsibility.

Senator GRAHAM. Colonel Warren, you are a very good JAG officer and a very good officer, and I know you are in a tough spot. But if you had talked about that slide an hour ago, that would have really helped. So just pipe up. [Laughter.]

Don't be bashful.

Now, I disagree with you a bit, General Abizaid, about a doctrine problem. I do not think we have a doctrine problem. I like our doctrine. Our doctrine, when it comes to trying to gather intelligence, is that anybody in Iraq is covered by the Geneva Conventions, and that we are going to follow the law because that is who we are as a nation. The idea that MPs—General Miller, I am talking to you now—can help the interrogators know what is going on in the cell block is a good doctrine, is it not?

General MILLER. Yes, sir, it is.

Senator GRAHAM. It is stupid to not be able to talk to the people who are running the jail about how the prisoner is doing that day before you interrogate him, right?

General MILLER. Yes, sir, that is exactly right.

Senator GRAHAM. Okay. For those who are watching, in the Arab world or anywhere else, can you get good intelligence and still be humane and decent?

General ABIZAIID. Yes, you can, sir.

Senator GRAHAM. Do you agree with that, General Miller?

General MILLER. Yes, sir, I do.

Senator GRAHAM. That is our doctrine.

Our problem is that these well-thought-out policies and procedures, when it came to practice, failed miserably, and that is why we are here, is that not true?

Now, let us talk about how that failure may have occurred. Colonel Warren, I need you to help me here.

Colonel WARREN. Yes, sir.

Senator GRAHAM. Pappas comes in November, is that correct, General Sanchez?

General SANCHEZ. Yes, sir, that is correct.

Senator GRAHAM. But we know that in October abuse is already taking place before he gets there, is that correct?

General SANCHEZ. Yes, sir, now we know that.

Senator GRAHAM. Okay. So there was a culture in that jail that was abusive before November. My question is, do we know if it changed after November in its tone or its application? Do we know the answer to that yet?

Colonel WARREN. Sir, I do not think we know. I think, as we have said, that the Fay Report may provide some insight, and also the CID report conducted by the Army is not yet final.

Senator GRAHAM. Is it true, or not, that some of the people in these abuse photos are common criminals?

Colonel WARREN. Sir, that is absolutely correct. We know, from the list of victims, that that is true.

Senator GRAHAM. So now we know that the abuse was not just directed at the high-value targets, but there was abuse going on, just in general.

Colonel WARREN. Absolutely correct, sir, and they should not have been in that cell block. That violated our orders and our policies.

Senator GRAHAM. So one thing we can find out pretty quickly is, in October, it is done to people who are not high-value targets. That jail was just sort of screwed up.

Colonel WARREN. Certainly, it would suggest, by the investigations and the evidence we have, that that statement is accurate. Yes, sir.

Senator GRAHAM. General Sanchez, I have never been in combat, but I do have some knowledge of the military. I have never seen a more dysfunctional command relationship, in the history of me looking at the military, like that jail. Do you agree with that?

General SANCHEZ. Sir, it was dysfunctional before November 19.

Senator GRAHAM. Right.

General Miller, the reason you were called over is to make sure that we not only did this legally, but to ensure we that got the necessary intelligence to win this war, is that correct?

General MILLER. Sir, I was requested to come over to give an assessment and then to be able to—

Senator GRAHAM. Is that why you brought him over, General Sanchez?

General SANCHEZ. Yes, sir.

Senator GRAHAM. I think you have done a great job at Guantanamo Bay. I am glad you brought him over.

People did not misunderstand what you said. They just totally ignored it. That is why we are here, is it not?

General MILLER. Sir, in my opinion, that is exactly correct.

Senator GRAHAM. Now, here is my problem. When it comes time to assess who ignored it, I am just not convinced that it is six or seven MPs doing this by themselves, because we know, in the photos, Colonel Warren, that there are people who are not MPs. We know that MI analysts and maybe interrogators are present at abuse situations.

Colonel WARREN. That is correct, sir.

Senator GRAHAM. Do I have your promise and pledge, all of you, that you are going to make sure that whatever information we get out of these court-martials will answer that question?

General ABIZAID. You do, sir, absolutely.

General SANCHEZ. Absolutely, sir.

Senator GRAHAM. I will give everybody an A-plus past January. I thank General Sanchez. You reported this appropriately to General Myers. Did you call him on January 14?

General SANCHEZ. Sir, I called General Abizaid.

Senator GRAHAM. Okay. Who called General Myers?

General ABIZAID. I did, sir.

Senator GRAHAM. You told him this was a big deal.

General ABIZAID. I did, sir.

Senator GRAHAM. He had every assurance that you were investigating it. So from General Myers' point of view—he is running this war—it is fair to say that, in January, he thought you were on top of it and you were investigating the matter, is that correct?

General ABIZAID. That is correct, sir.

Senator GRAHAM. So when we look at responsibility up the chain, the Chairman of the Joint Chiefs was informed that it was being investigated in early January.

General ABIZAID. I would say immediately, yes, sir.

Senator GRAHAM. Please, if you can, explain how the abuse could have happened at this level, for this long, with this much devastation to our country, and no one knew about it before January in the photos given over by the specialist?

General ABIZAID. Explain how the abuse was taking place between October and November with us not knowing about it?

Senator GRAHAM. How did it happen so long and so deep without us knowing?

General ABIZAID. Well, I think there are failures in people doing their duty, and there are failures in systems. We should have known, and we should have uncovered it and taken action before it got to the point that it got to. I think there is no doubt about that. I have asked myself the question, as I am sure everybody else in the chain of command has, what could and should we have done differently? I can think of some things that we have to do. We have to ensure that we have transparency with the ICRC, for example. We have to ensure that there are other methods—just like when we had this problem that we looked at during the movement phase of the war, where there were a lot rapes and sexual assaults going on that were unreported. When we looked at our systems, what we have at Fort Bragg, North Carolina, does not get replicated on the battlefield.

So, Senator, there is a lot of work we have to do, and we have to fix this one so it doesn't happen again.

Chairman WARNER. Thank you very much, Senator.

Senator Lieberman.

Senator LIEBERMAN. Thank you, Mr. Chairman. Thanks to the witnesses.

Obviously, I express not only my gratitude for your service, but my support for the mission we have sent you to Iraq to carry out. I think it is the test of a generation, and I appreciate your confidence as you go forward, because it is going to have a lot to do with our future security. It makes why we are here all the more heartbreaking and infuriating, because it distracts us from that mission. But I absolutely agree with you, we have to go at this. Casualties occur in a war. The tragedy here is that this prison abuse scandal is a self-inflicted wound. But, like any wound, we have to clean it up, fix it up, and then try our best to make sure it does not happen again.

I want to express, first, my concern that, on more than one occasion, at least two of you today—and you are honorable people, obvi-

ously, under oath—have taken specific objection to parts of General Taguba's report. That report has received a lot of credibility and I believe it was a report, General Sanchez, to you. Should we think less of it because of the objections raised today? General Miller's response to a question Senator Clinton asked said that something that he was reported to have done or seen just did not happen. You have separated yourself from conclusions in the report on a few occasions. Does it lead you to doubt the thoroughness of the report, or lead you to feel, as the commander, that you ought to send somebody else out there?

General SANCHEZ. No, sir, it does not. As we have stated here, there are some differences, there are some concerns with our doctrinal foundations and the conduct of MP and MI operations, and I think that is what is reflected there. We have to fix those over time.

Senator LIEBERMAN. So the areas in which you disagree—and you have heard that General Miller has disagreed with General Taguba's report—you are pursuing in different ways, then.

General SANCHEZ. Sir, where I disagreed with the report was in my placing the 205th MI commander in charge of force protection and security of detainees.

I believe that was exactly the right decision to make, given the circumstances, the tactical circumstances, and the warfighting conditions that existed—

Senator LIEBERMAN. So, in that case, your disagreement is on a matter of judgment, really, not fact.

General SANCHEZ. Absolutely, sir.

Senator LIEBERMAN. General Miller, yours is a matter of fact.

General MILLER. Yes, sir, mine is a matter of fact. The incident that Senator Clinton brought forward—

Senator LIEBERMAN. In your testimony, you said it did not happen.

General MILLER. Yes, sir, that is correct.

Senator LIEBERMAN. Let me go on to another concern of mine that follows up on Senator Graham's questions. Let me preface this by saying, in taking some notes myself, General Abizaid, you said two things here today that I want to come back to. One is that, to the best of your knowledge, there was no pattern of prisoner abuse in your command. Second, you expressed a belief that there were systemic problems that existed at Abu Ghraib that may have contributed to events there. Obviously we are all interested in trying to figure out when a reasonable person in a position of responsibility would have found that out.

The decision by the Pentagon to send General Miller to Iraq, and then your decision, General Sanchez, to get Colonel Pappas involved—am I correct, General Sanchez, that you are saying that that decision was made because of your concern that conditions at Abu Ghraib were as—I think someone used the word; maybe you did, yourself—dysfunctional? Is that correct?

General SANCHEZ. Sir, that is exactly right. It was dysfunctional in terms of the ability to defend the FOB. That was the judgment that I expressed in the issuance of that Fragmentary Order.

Senator LIEBERMAN. Got it. Well, that is what I wanted to clarify. But, at that time, the dysfunction that you saw in Abu Ghraib did not include your knowledge of prisoner abuse. Is that right?

General SANCHEZ. Sir, that is exactly right.

Senator LIEBERMAN. General Miller, your understanding of the reasons why you were dispatched to Iraq last fall did not include—or did they?—a concern about prisoner abuse.

General MILLER. Sir, they were not focused on the concern about prisoner abuse. They were about the overall capability of CJTF-7 to develop actionable intelligence, to do intelligence fusion, to see how interrogations were conducted.

Senator LIEBERMAN. Your stress on humane treatment, on the Geneva Conventions, was of your own initiative, not because anyone, as they dispatched you to Iraq, had said, “We think we have a problem of prisoner abuse.”

General MILLER. Sir, that is absolutely correct.

Senator LIEBERMAN. Let me now go to this chart that has received so much attention. I have to say, again here, this was put before us by General Alexander, the general in the Army who is in charge of intelligence, so the fact that it comes from a lower-ranking—well, a company commander, Captain Woods, is surprising. Now, maybe it was given to us in the context of this investigation because it is not all bad news for the Army. It does have a series of approved approaches for all detainees on the left here, which certainly, to me, seems reasonable. At the bottom, it lists safeguards, including “approaches must always be humane and lawful, Geneva Conventions apply.”

The problem is this section here on the right, and Captain Woods told anyone who saw this chart that it required General Sanchez’s approval. Some of these seem reasonable, some of them literally seem in violation of the Geneva Conventions.

I wanted to ask you, Colonel Warren, two questions. First, how could Captain Woods have come up with these sections that she said required the commanding general’s approval if the commanding general had not approved this chart? Second, do you agree that the procedures listed on the right side, including environmental manipulation, sleep adjustments, and sensory deprivation, are, in fact, violations of the Geneva Conventions under all circumstances? Because I thought in your answer to Senator Reed earlier, you opened a door in which you were suggesting they might not be. If so, I think it is very important for the committee to hear that.

Colonel WARREN. My answer is that they are not.

Senator LIEBERMAN. That these are not violations of the Geneva Conventions?

Colonel WARREN. These are not, in and of themselves, in isolation, violations of the Geneva Conventions. Specifically, the Fourth Convention, when applied to security internees—in this case, who were unlawful combatants.

Senator LIEBERMAN. Which covers a number of the people at Abu Ghraib, is that right?

Colonel WARREN. It does. It should cover those who, in this circumstance, would have been permissibly under active interrogation. As was pointed out by Senator Graham, some of the people depicted in these photographs should not have been under interro-

gation at all; they were of no interest. They were actually criminal detainees who should not have been in that cell block in the first place.

But that as an aside, sir, this is more complicated than a yes or no answer. Those things that were on the right that were placed there by Captain Woods, as I said earlier, sir, were placed there in order to show the range of the universe, if you will, of things that were not authorized. They were representative.

Senator LIEBERMAN. Where did she get the authority to not only put them down on paper, but to say that they required the approval of General Sanchez? She is a captain.

Colonel WARREN. I think I can explain that, sir, because, again, I was present throughout as this policy developed.

Senator LIEBERMAN. Please, with the chairman's consent, if you would just take a moment to go over this.

Colonel WARREN. If I might.

Chairman WARNER. The witness will have adequate time to respond.

Colonel WARREN. Thank you, sir. This goes back to General Miller's team's visit, where they looked at a broad range of interrogation and intelligence analytical operations. Their recommendation was that we should have an interrogation policy. We, as a task force, did not have one. We were focused on the tactical level of interrogations. We were following predominantly Army Field Manual approaches. In addition, we had other units, such as Alpha Company 519th MI Battalion, which had served in Afghanistan, bring in their own policies that have been used in other theaters.

Additionally, we had what we called the Common Law of Interrogation Approaches, and that consists of approaches which were variations on the authorized approaches contained within the Army Field Manual by way of implementation. So the point that was made, to have a policy, I believe, was a reasoned and correct recommendation, and I was present at meetings in which—

Senator LIEBERMAN. Reasoned and correct.

Colonel WARREN. Reasoned and correct, absolutely, sir. I believed we needed to have one as we moved our focus to the operational level, as we became more sophisticated, and, frankly, if we wanted to stem the growth of this Common Law of Interrogations so that we could regularize it, so that we could regulate it, and so that we should be able to provide proper oversight.

So we took a number of these SOPs and policies. Among them were those in use in Guantanamo Bay. Others were, as I mentioned, those that were imported into theater. We put together a team of folks who were MI and legal officers. We looked at those policies, we reviewed them against the requirements that we believe were imposed by the Fourth Geneva Convention. We discarded some of those procedures. An example is sensory deprivation. We floated these through the command in a series of drafts.

To be sure, in some of these drafts—specifically one dated September 10—you may very well find all of those on the right-hand side, including sensory deprivation. But during the course of the staffing and the deliberative process and the review—and, sir, by no means is there a book that you can look up that runs through interrogation approaches and methods and has a check and a block

that they comply or do not comply with the Geneva Conventions—this is a matter of judgment, a matter of rigor, and a matter of oversight and interpretation. We came up with the interrogation policy first dated September 14. We then sent that to CENTCOM, as General Sanchez described.

During the course of the next 28 days, this deliberative and consultative process continued within the legal and the MI community. It resulted, ultimately, in the October 12 policy. The October 12 policy, as I described, requires compliance with the Geneva Conventions. It draws a legal contrast between POWs and between security internees interned for suspicion of hostile activity to the security of the state, and it requires the safeguards and oversight mechanisms I described. That policy contains only the field manual approaches, which applied to enemy POWs who enjoyed the highest, most preferred status on the battlefield plus segregation in excess of 30 days. When Captain Wood at some point, we believe in October, prepared that slide, what I believe that she did was to take all of the approaches that were floating around the command, if you will, in various drafts, and within the policies listed them to ensure that interrogators understood that only those things on the left were authorized without permission.

Senator LIEBERMAN. But again, you would say that of the group on the right, which has attracted the attention of the committee, the media, and the public, none of these are inherently or automatically in violation of the Geneva Conventions?

Colonel WARREN. In my opinion they are not, sir, and this is why one has to read not just Article 31 of the Fourth Convention but also Pictet's commentary and various legal treatises and interpretations of coercion as applied to security internees.

I will make another point, sir, with regard to the environment in which we found ourselves. Remember that there were three Geneva Conventions, initially. In the 1929 iteration, after World War II, the Fourth Convention, the Civilian's or Occupation Convention, was added. The body of case law, if you will, concerning interpretation of specific articles within the Fourth Geneva Convention is not very great at all. In fact, as we worked through this we did the best we could do under the exigencies of the circumstances and I am frankly very comfortable, sir, with that October 12 policy that remained our policy for a period of 8 months.

If I might add one other thing, sir. It is very important—and this is a problem with a chart like this—it is very important that you understand the definitions which are contained, for example, in the field manual and the policy of some of those measures. To use a term I have learned in the past week in Washington, the optics are bad on that chart. But if you read the actual definitions you will find, for example, with regard to environmental manipulation, it sounds horrible. But the fact is that environmental manipulation can be as simple as, while at all times maintaining the minimum requirements of the Geneva Conventions, that a person who cooperates in interrogations would get an air conditioned room. A person who is not cooperating gets the minimum, non-air conditioned room. Each of those approaches has to be laid out, in writing, in an interrogation plan. Each of those interrogation plans is reviewed at the brigade level. For an exception to policy it comes

up for legal and senior intelligence review before going to the commanding general. So the intent of the chart, frankly, was to regulate, not to impose unlawful measures.

Senator LIEBERMAN. So though General Sanchez did not see the chart before last week when General Alexander put it before us, it accurately reflects what you think is the appropriate policy for interrogation?

Colonel WARREN. Those on the left and the safeguards, absolutely. Those on the right, again, are the range of things that may very well in implementation not be authorized. In particular, given the intensity, the magnitude, the duration, and the combination of measures, they may very well, as Senator Reed suggested, violate the Geneva Conventions. You have to look at it on a case-by-case basis.

Senator LIEBERMAN. But obviously you would agree that a lot of what we have seen in pictures that occurred in a particular cell-block in Abu Ghraib violated the Geneva Conventions?

Colonel WARREN. No question about it, sir. They also violated U.S. law and that is why we are seeing court martials.

Senator LIEBERMAN. This chart?

Colonel WARREN. Absolutely, sir.

Senator LIEBERMAN. Thank you very much.

Chairman WARNER. Thank you very much, Senator.

Senator Cornyn.

Senator CORNYN. Thank you, Mr. Chairman. I guess we can conclude that not even the combatant commanders can go very far without their lawyers, correct, General Abizaid?

General ABIZAID. I am going to hire Colonel Warren.

Senator CORNYN. I do not think any of us should be surprised that at least six separate investigations occurring in a war zone might occasionally come up, at least in a preliminary fashion, with some conflicts or gaps in the investigation. But I want to make sure that we understand, at a baseline, where we are.

General Abizaid, is it not true that in basic training our soldiers receive training on the Geneva Conventions?

General ABIZAID. Yes sir, that is true.

Senator CORNYN. Also, prior to their deployment to the theater of operations they receive retraining on the terms of the Geneva Conventions?

General ABIZAID. They are supposed to, yes sir.

Senator CORNYN. I believe that you have made very clear that under no circumstances, no matter what the category of detainee may be, that at a basic minimum everyone in the custody of the United States Military is entitled to be treated humanely. Is that correct, sir?

General ABIZAID. That is correct, sir.

Senator CORNYN. I believe very strongly that in addition to the hearings that we have had here, which hopefully will, after they conclude, allow our military to get back and do what we have asked you to do in Iraq and Afghanistan, and that is defeat the enemy. That we have to let our military justice process work.

But General Sanchez, you suspended the entire chain of command, not just privates and corporals, on January 17 or thereabouts. Is that correct?

General SANCHEZ. Yes sir, that is correct.

Senator CORNYN. So just to be clear, no one is pointing the finger at the lowest level of our military food chain and saying, "You are at fault and the commanding officers are being protected." Is that right?

General SANCHEZ. Sir, that is correct.

Senator CORNYN. General Miller, I had the pleasure of traveling to Guantanamo Bay, like a number of committee members have, and meeting you there. I was enormously impressed with that operation. There have been some who, during the course of these hearings, have suggested that perhaps because of the various categories of detainees we have in different locations, whether in Iraq, Afghanistan, or Guantanamo Bay, there is some variation in terms of the acceptability of humane treatment. But would you also confirm for us that at a minimum everyone, regardless of their status at Guantanamo Bay or anywhere else, to your knowledge, is entitled to be treated humanely?

General MILLER. Yes, Senator. Every combatant who is at Guantanamo is detained in a humane manner.

Senator CORNYN. In your opinion, General Miller, has the intelligence that you have been able to gain from those who have recruited, financed, and carried out terrorist activities against the United States or our military saved American lives?

General MILLER. Senator, absolutely.

Senator CORNYN. Would you confirm for us, General Abizaid, that that is also true within CENTCOM?

General ABIZAID. Senator, I agree that it is true. I would also like to add that some of these people who we are dealing with are some of the most despicable characters you could ever imagine. They spend every waking moment trying to figure out how to deliver a WMD into the middle of our country. We should not kid ourselves about what they are capable of doing to us, and we have to deal with them.

Senator CORNYN. If we needed any other reminder of that, the death of Nicholas Berg, I believe, reminded us, again, in a graphic fashion. But I, for one, am not troubled by the fact that some person who is trying to kill Americans is deprived of a good night's sleep in order to elicit information, consistent with the Geneva Conventions and our laws and humanity that might save American lives. I consider you all American heroes and congratulate you for the job that you are doing.

Thank you, Mr. Chairman.

Chairman WARNER. Thank you very much, Senator.

Senator PRYOR.

Senator PRYOR. Thank you, Mr. Chairman. General Abizaid, according to The Washington Post on May 8, 2004, starting in August 2003, Ambassador Bremer had concerns about the treatment of detainees and pressed the military to, "improve conditions, and later made the issue of regular talking points and discussions with Secretary Rumsfeld, Vice President Cheney, and National Security Advisor Rice." The same Washington Post article notes that in August 2003, Ambassador Bremer, "After interceding in one detainee's case, urged the U.S. Military in Iraq and top Bush administration

officials to improve conditions and avoid potential fallout.” General Abizaid, is that statement I just read essentially true?

General ABIZAID. Ambassador Bremer brought up to me on one of my many trips to Iraq, on more than one occasion, his concern about detainees.

Senator PRYOR. Okay, so you were aware that Ambassador Bremer had concerns about the treatment of detainees. Were you also aware that he raised this matter with a wide array of senior administration officials?

General ABIZAID. I am not aware of that, Senator, but as I understand the context of Ambassador Bremer’s and my discussions, and also the context of discussions that I had with many Iraqis who were talking to me about the detainee issue, it had to do with moving into the prison system, being lost sight of because we did not have a good tracking system, not being able to get information to families in a timely manner. These were things that we were all concerned about. General Sanchez and I talked about them, and we certainly knew that the detainee system had to be such that we could identify people, track people through the system, and then release people in a timely fashion back to their families once we had determined that they served no intelligence purpose to us. Until General Miller got there—well, I should not say that. We were struggling with this very early on and I will not make any excuses for it other than to say, when you take a country in the shape that we took it, everything was broken and we were starting from zero.

Senator PRYOR. But are you saying that Ambassador Bremer did not have concerns about human rights violations? It was more a clerical concern?

General ABIZAID. To me the issue was how you want to describe human rights violations, as far as the Arabs were concerned and then Ambassador Bremer was concerned. “My husband disappeared into your prison system and now you guys cannot find him.” That is a human rights problem. I agreed with him and Rick agreed with him and we moved to fix it.

Senator PRYOR. Okay. General Sanchez, were you aware that Ambassador Bremer had concerns about the prison system?

General SANCHEZ. Sir, on many occasions since the time I became the commanding general of CJTF-7, Ambassador Bremer and I had discussions about detainee operations. We talked, as General Abizaid stated, about the identification, the in-processing, and the release procedures.

Senator PRYOR. What about the treatment of the prisoners and detainees?

General SANCHEZ. We also talked at some points about the quality of life of prisoners and the conditions that existed, especially during the summer and into the early fall.

Senator PRYOR. Do you recall when he first brought those to your attention?

General SANCHEZ. Sir, it was not a matter of him bringing it to my attention; it was a part of general discussions that we were having.

Senator PRYOR. Do you remember when those general discussions started?

General SANCHEZ. Sir, we started having those in the mid-summer time frame.

General ABIZAID. Senator, if I could just add, there is another issue here which I want to make clear to the committee. It has to do with what goes on at the point of capture. This is not police work that we are dealing with, it is not a standard arrest, it is combat, and there were an awful lot of people in Iraq at the IGC level that thought our troops were being too harsh in the way that they took people into custody. In my mind, having seen it personally on the battlefield, I thought, and I still think, it was some of the most professional work I have seen young troopers do anywhere. So, we did have a different point of view in that regard.

Senator PRYOR. General Sanchez, let me follow up with you, if I may. You mentioned you were having these general discussions about conditions and a variety of issues relating to the detainees. When did you first start to report that up the chain of command, and who did you report that to?

General SANCHEZ. Sir, there were multiple occasions when General Abizaid and I had discussions, especially as they related to actions at the point of attack.

Senator PRYOR. Here again, do you remember when that started?

General SANCHEZ. Sir, as I stated, immediately.

Senator PRYOR. As soon as you were aware of it.

General ABIZAID. Senator, let there be no doubt. We knew there were problems in the detainee system. We did not think that there was a set of conditions existing out there such as we have seen in the photographs. But we knew that there were problems and we moved to get them under control as quickly as we could. When I say immediately, I took command in July and I would imagine that, besides talking about operational matters, one of the first things that the two of us talked about was how we had to get this under control.

Senator PRYOR. General Abizaid, when you talked to your superiors, who did you talk to?

General ABIZAID. Sir, I cannot recall specifically mentioning the problem to the SECDEF or to the Chairman of the Joint Chiefs of Staff, but on one of their visits and during one of our phone calls—we talk all the time, and there is a free exchange of information—they would have known. I do not think that Don Ryder coming over to look at the system was indicative of us trying to sweep the problem under the table; it was indicative of us trying to fix the problem.

Senator PRYOR. Thank you. Thank you, Mr. Chairman.

Chairman WARNER. Thank you, Senator.

Senator Inhofe.

Senator INHOFE. Thank you, Mr. Chairman. One advantage of going close to last is that you can cross things off your list. I have done a lot of crossing off. Let me just share a concern. During the last 3 hours there have been eight references to different newspaper accounts, some of them with the same newspaper several times. Of the articles that were written, there are four of them that have been categorically denied by you, General Abizaid, or by General Sanchez, and I believe you in that. It leads me to believe this is so press-driven that it is just out of control. But when you get

your briefings every morning, I know you read the different articles in the paper that affect you. Is that not correct?

General ABIZAID. Yes sir.

Senator INHOFE. There are many times that you have found that they are in error, and I am sure you have either directly or indirectly called that to the attention of the newspaper or the publication that gave these in these articles. Is that correct? You have done it right here in this setting.

General ABIZAID. Well sir, there are a lot of things that are incorrect. I do not spend much time correcting them.

Senator INHOFE. Well, I would hope you did not but I guess I would ask this: have you ever seen a retraction by any of these newspapers when something is proven to be wrong?

General ABIZAID. No sir.

Senator INHOFE. All right. I have not either. I think Senator Collins was right when she talked about all the good things that are happening that you just do not see in the media. Not just the humanitarian things that we see when we go over to Iraq and go to Afghanistan and see what these great guys and gals are doing and how much they are loved by the people over there. In the case of Afghanistan, General Abizaid, the Oklahoma 45th, they have taken on the responsibility of training the Afghan National Army to train themselves, and they are doing a great job. When I was over there I watched the expressions on the faces of the new Afghan commanders, teaching and training their troops. This is something that would be worthy, certainly, of publication. I dare say very few people, not half of 1 percent of the people in America, know all these good things that are going on. Quite frankly it just breaks my heart to see you guys over here. I agree with what Senator Graham said, that we have to air this out and get it out in the public but we have already had the SECDEF, the Under Secretary of Defense, the Chairman of the Joint Chiefs of Staff, and the Vice Chairman of the Joint Chiefs of Staff, and quite frankly, I am sorry that you guys are here. I would rather be handling this in some way where we can get your statement, get it in the record and have that done with. Because you have an awesome responsibility. General Sanchez, as commander of CJTF-7—that is all the Army, all the Navy, all the Air Force, all the Marines, all the coalition forces, all the allies—that is your responsibility in Iraq. General Abizaid, you have that responsibility plus what is going on in Afghanistan. By the way, I think that the Afghanistan success story should serve and will serve as a model for what we are trying to get done in Iraq.

So, that is just one opinion. I know that you are anxious to get back to the battlefield and that is where your mind is today and that is where your heart is. I did talk to Senator Warner when I found you were going to be here and he assured us that you had other reasons to be here. So, perhaps that takes care of that.

I think some things are worth repeating. I think that until we see the Fay Report, until we get the results of the investigations, the results of the courts martial, we are not going to have the answers. This concept of undue command influence puts you in a very awkward position to say things, and I hope in your own minds you have not said anything publicly that is going to interfere with the

prosecutions that are going on. Do you feel pretty comfortable that you have been able to do that?

General ABIZAID. Yes sir, I do.

Senator INHOFE. I look at what happened when things were discovered and I was amazed with how quickly things were done, how quickly you took care of the problems that were there. The guards were removed, the commanders were relieved, criminal investigations started immediately. That was long before the public even knew what was going on, long before the pictures came out. Maybe the system is broken but it is not broken to the extent that you did not perform immediately when you found out what was going on.

I want to say one thing, and this is just an opinion. There are a lot of people who have been critical that some of the guards, the seven guards that have been referred to many times, are taking the heat for all of this. I do not think there is an American out there, once they see the videos and the pictures that we at this table have seen of the behavioral pattern of these guards, who would be at all critical of any kind of punishment that they would be subjected to. Now, I am not saying anything that has not already been in the paper. I was very careful, after I saw those, not to say anything. But others did, and they talked about the fact that this was like they were staging a porn film. Well, this is something that no one would condone. You folks would not; no one else would. So I just think that we need to talk about the good things that have been happening and get you back in the battle where you belong.

Before I run out of time, General Sanchez, there have been several things that you have taken away in terms of interrogation techniques. Do you think that has harmed your ability to get the information that you need to have?

General SANCHEZ. No sir, it has not.

Senator INHOFE. Okay. Colonel Warren, I believe it was you who said that, yes, in cellblock 1-A and 1-B those are the tough guys, those are the terrorists. But occasionally one gets in there who is not. I would suggest that probably the profile of that individual got them there and when you realized that they did not belong there you took them out. General Miller, is that what you think might have happened?

General MILLER. Sir, I was not there when they were using cellblock 1-A and 1-B, but in discussions that was the intent early on in September.

Senator INHOFE. Okay. Well, I knew that you were not there at the time. In fact, I was down at Guantanamo Bay when you were there and you just did great work down there. My time has expired, but I am glad that Senator Cornyn brought up something most significant, and that was, did any of the information that you have been able to get from these detainees prevent something bad from happening or save American lives or save coalition lives and, if so, are there any specific examples that you would like to share with us? In other words, you were successfully interrogating some of these people in that particular section. Was some of the information that you got helpful in saving American lives or saving troops?

General ABIZAID. Senator, I do not know the answer to that. I certainly do know that in many cases good interrogation techniques

used by very smart people have saved the lives of an awful lot of Americans and Iraqis.

Senator INHOFE. Thank you very much.

General MILLER. If I could just add to that. General Sanchez, as one of my new jobs as the Deputy Commander for Detainee Operations, asked me to look at the intelligence function. I tell you that half the effort of CJTF-7, now Multi-National Force Iraq, is going down to develop actionable intelligence at the unit level. That saves soldiers' lives every day. The other 30 percent goes toward theater-level things that come down from the commanders' decision or in taskings from other organizations. The other 20 percent we just keep as a standby that is used every day because of high profile. So that system, that organization works every day and every night to try to be able to provide actionable intelligence.

Senator INHOFE. Thank you, General Miller, and I hope that the media is paying attention today after you gave—I know my time is up, but Colonel Warren wanted to say something about Article 32 early on.

Chairman WARNER. Please, Colonel Warren.

Senator INHOFE. Is there anything you would like to say about Article 32?

Colonel WARREN. Well sir, Article 32 of the Fourth Convention is the one that prohibits torture and the conduct of medical experimentation and so forth. Those are grave breaches under the law of war. Of course, obviously prohibited under our policies, under our values, our standards, our training, and our interrogation policy.

Chairman WARNER. Thank you, Senator Inhofe.

General SANCHEZ. Mr. Chairman, may I add something?

Chairman WARNER. Yes, General Sanchez.

General SANCHEZ. As a result of the two visits from General Miller and then from General Ryder, the system that we put into place for intelligence fusion within CJTF-7 matured significantly because of the experience and the lessons and the integration of those lessons into the command under General Fast. There is absolutely no question in my mind that because of those two efforts, significant amounts of Americans' lives have been saved because of the turn in terms of from the time we find the information, develop the intelligence and get it to the tactical level for action, it is absolutely the right thing for us to have done and I would do it again.

Senator INHOFE. Thank you for that answer.

Chairman WARNER. Thank you. General Sanchez, in my most recent visit I met with General Fast. Would you kindly explain the position that she occupies?

General SANCHEZ. Yes sir. Brigadier General Fast has been my Director for Intelligence of the CJTF-7.

Chairman WARNER. Thank you very much.

Senator Bayh.

Senator BAYH. Gentlemen, thank you for your service to our country under most difficult circumstances. I can only hope that your treatment at our hands today has been humane. I sometimes feel empathy for those who are on the receiving end of these hearings.

General Abizaid, who was responsible for the staffing levels at the prison, for the number of MPs and prison guards?

General ABIZAID. I would say the responsibility for a unit coming with the right number of people belongs to the United States Army. The responsibility if we have shortages then devolves upon CJTF-7 to tell me so I can tell the Army to fix it.

Senator BAYH. The reason I ask is I understand Army doctrine calls for one MP brigade per about 4,000 prisoners, and here we had one battalion for what ultimately reached about 7,000 or slightly more prisoners, or about five times the number of detainees per guard or MP that the Army doctrine would call for. I would like your opinion—and there have been some reports to this effect—this substantial overcrowding did not excuse the behavior, of course, but did it contribute to an atmosphere which might have given rise, at least in part, to this aberrant behavior?

General ABIZAID. Well, it contributed to systemic failures at the prison. I think that is clear.

Senator BAYH. It gets to my second and somewhat broader concern, now that I have had a chance to reflect upon this whole set of circumstances. I would like your opinion, both with the benefit of hindsight and going forward, on whether we have adequate troop strength in Iraq to accomplish our mission. I have been concerned from day one, and I know Senator McCain and some others have had this concern, that we did not have adequate strength at the beginning to prevent some of this rampant looting that took place; that we did not have adequate troop strength to prevent some of the sabotage of vital infrastructure that took place; that we did not have adequate troop strength to immediately clamp down on the insurrection which has now gathered a momentum all on its own. I wonder if, just in a microcosm, this is another manifestation of our continual underestimation of the task that we have taken on here. In a situation like this where we are deposing a regime, we are trying to reconstitute a country with no history of democracy, it seems to me we should err on the side of having more strength than necessary rather than too little.

Both looking back and looking forward, have we had adequate troop strength and do we have adequate troop strength to accomplish our mission with this critical June 30 handover fast approaching?

General ABIZAID. Have we had adequate troop strength? Certainly in February I would have told you absolutely. Things were where we thought they would be. Did we anticipate that there would be additional violence as we moved towards a political process? We did, and that is the reason I asked for the troops from the First Armored Division and the Second Armored Cavalry Regiment to remain there, although we did not specify them particularly. I would like to point out that one piece of hugely good news that has been lost in this period of the Abu Ghraib scandal is the incredible work and bravery and selflessness and military capability of those two units, as well as have the Marines in moving from positions in contact in Baghdad down into the south and fighting a very tough fight.

But to answer your question directly—and forgive me for diverting—Senator McCain and I have had the opportunity many times to discuss it and I appreciate his opinion. There are certain types of troops that we do not have enough of and we still do not have

enough of them, and we have to figure out how to get them. They are MPs and they are MI guys and they are human intelligence guys and they are civil affairs people. We must build a force structure that allows us to be able to fight a war like this in the 21st century and they are not in the force structure. We have MPs on the scene that the Army has done a very good job in training that do not happen to be MPs. We have Air Force truck units. We are doing things with our force structure that, in my view, we need to sit back from a service provider point of view and say, "Okay, what do we really need?"

Now, in terms of asking are there enough tanks, are there enough Bradleys, are there enough combat troops, marines, etcetera, I am pretty comfortable with that. It is the enablers I am not comfortable with. I will end it up by saying I am also not comfortable that there are enough international troops on the battlefield because the effort needs to be not just American, but it needs to be international. These are things that I have said, I believe, to the committee on numerous occasions.

Senator BAYH. It is not new thinking.

General ABIZAIID. Did I miscalculate the number of troops? Maybe. Maybe I miscalculated, but I think we have adjusted and will continue to adjust based on what the enemy does, because the enemy has a vote.

Senator BAYH. The civilian leadership always places this at your doorstep, saying that they are endeavoring to get you everything you need and I certainly appreciate that. But Deputy Secretary Wolfowitz began to touch on this, I think, yesterday in some of his testimony up here in a different capacity, when he said this is not only a military undertaking, this is a political undertaking. I am just wondering if those who felt that we were going to be greeted as liberating heroes, so to speak, perhaps did not underestimate the magnitude of the societal transformation we have taken on. This goes way beyond the military purview, and I am just wondering if, given the magnitude of that task, we have been understaffed and this is just another manifestation of that.

General ABIZAIID. Well Senator, I cannot comment for the political side of the house, but I can comment in saying that while we cannot be defeated militarily we are not going to win this thing militarily alone. We have to get everything together—economics, politics, intelligence, information, you name it—it all has to come together in a synchronized fashion that allows us to do this very important task. It is really one of the hardest things that this Nation has ever undertaken in this part of the world or anywhere else.

Senator BAYH. Gentlemen, several of you have indicated in response to recent questioning that lives have been saved, attacks have been prevented with access to timely and accurate intelligence. I think, General Miller, you have indicated that approximately 600 of these detainees are some of the worst of the worst and that if released upon Iraqi society they would not only imperil our forces, but also innocent Iraqis. Colonel Warren, I think you indicated that the Geneva Conventions would allow somewhat more vigorous interrogations of some of those kind of folks, but with the exception of a few requests for solitary confinement we have not

gone there. Is that all correct? Stress positions were requested but were not permitted.

Where I am going with all this is that it is so important that we strike the right balance here. On the one hand, timely intelligence saves innocent Iraqi lives and the lives of our troops. On the other hand, there is a dividing line beyond which our moral integrity, our honor is vitally important if we are going to win this war against terrorism because we do stand for something better. So what has been brought before this committee with these pictures, which obviously go to the latter issue of who we are and what we stand for, let us not lose sight of the former, either.

The pictures that stick in my mind also, Mr. Chairman, are the pictures of the young men out there at Walter Reed, some of them missing arms, some of them missing legs, fractured lives in the full flower of their youth. The pictures that came out of those flag-draped caskets. Those pictures are important, too. So, there is no excuse for the behavior that gave rise to the pictures of this abuse at this prison. We have to root it out and some of these individuals are on trial. But at the same time, let us not repeat some of the mistakes that we have made in the area of covert intelligence where the Director of the CIA now tells us it is going to take 5 years to reconstitute our covert capabilities and adequately protect this country. A balance is in order here and I just hope that we are empowering you to strike that balance in ways that protect our brave men and women on the one hand and preserve our honor on the other.

Chairman WARNER. Thank you very much, Senator. Is there a desire for any witness to speak? If not, Senator Dole.

Senator DOLE. Thank you, Mr. Chairman. Gentlemen, I certainly want to join my colleagues in thanking you for your tremendous leadership and your outstanding service to your country. Like Senator Cornyn, I regard you as heroes sitting in front of us today, and I thank you for your time with us. Since all of you have been very forthcoming in the last 3 hours of questions, I would like to take this opportunity to ask some questions with regard to your overall Iraqi operations.

First of all though, General Miller, let me ask you, would you clarify who will be in charge of running the Iraqi prison system after June 30?

General MILLER. Senator, that is still in dialogue and discussion between the CPA, the IGC, and now the soon-to-be Interim Iraqi Government. Those transitions are working. I will tell you that as far as Multi-National Forces Iraq, our plan is to continue to run our theater-level, our Multi-National Forces Iraq three detention facilities and other detention facilities that allow us to ensure we can implement a safe and secure environment. But as we work towards transition, every day I meet with my Iraqi counterparts to see how we can more successfully move to integrate this operation.

Senator DOLE. Thank you. Now, in an intercepted letter written by al Qaeda operative Abu Musab al-Zarqawi, we were given insight to a terrorist message that was very significant and compelling. In noting concern that he may lose a foothold in Iraq he wrote, "With the spread of the army and the police, our future is becoming frightening." He went on to detail the very environment

of chaos his network requires to succeed—attacks on Iraqi security forces, the targeting of Kurds, the Shi'ite populations, and the killing of Americans—the very environment evolving in Iraq that he feared the coalition forces would suffocate.

General Abizaid, several reports have claimed that Zarqawi is in Baghdad. If he actually got into Baghdad past coalition forces, can we assume that he has the mobility to move to other regions in Iraq?

General ABIZAID. Senator Dole, I would assume that Zarqawi has the ability to move around the Nation, unfortunately. The nature of the insurgency is one that you cannot stop one person from moving where you would not like them to move, even as visible as they may be. He can move around, he can strike at will, and we have reason to believe that he was in Jordan recently and had his hands in the plot that would have killed thousands and thousands of Jordanians that was foiled by the king's special forces and intelligence forces. So there is a great battle going on in the region. It not only extends to Iraq, but it is in Saudi Arabia. It should come as no surprise to the committee that these people are also attacking foreigners in places like Saudi Arabia. There is a strategy at work here that we should not lose sight of, and it is happening in Afghanistan and it is happening in Pakistan, Saudi Arabia, Jordan, and elsewhere in the region, and it is also happening in places like Madrid.

Senator DOLE. Can you confirm that Zarqawi beheaded Nicholas Berg?

General ABIZAID. I do not know that I can confirm that it was him. I know that there are various reports of people saying it is his voice on the tape. I know he has claimed it, and it certainly would not be past him.

Senator DOLE. General Kimmitt said that the killing of Salim had the classic hallmarks of Zarqawi. Do you have any further information to share with us on that?

General ABIZAID. No Senator. I would not want to give Zarqawi any stature he does not deserve. He is a murderer, he is a torturer, and that is the status he deserves.

Senator DOLE. Do you have any indication that al Qaeda is coordinating with al-Sadr's resistance?

General ABIZAID. That is a very good question, but I think the answer is no. But in that part of the world you never know.

Senator DOLE. Saddam Hussein's government was believed to have produced several hundred tons of sarin as well as stockpiles of mustard gas. Now, the presence of both sarin and mustard gas has been reported in Baghdad. Do our men and women in theater have the equipment, the devices that they need in order to protect themselves from the exposure to such agents as these? General Sanchez?

General SANCHEZ. Yes ma'am. The answer is yes, we do. We deploy with all of our chemical, nuclear, biological capabilities and those are present.

Senator DOLE. General Abizaid, defense contractors and private business representatives, of course, are critical to reconstruction efforts and rebuilding in Iraq. Terrorists seem to have shifted their focus; they are targeting these unarmed civilians. A corporation from my home State of North Carolina, Blackwater, of course, with

four contractors who were shot, burned, and hung from a bridge; Nick Berg's murder—what are you doing to provide increased security for these unarmed civilians?

General ABIZAIID. I think it is best left for General Sanchez to talk about the details, but it is clear that the enemy has discovered a vulnerability in the contracting system. It is also clear that we have to work with the contractors to protect them, not only in coordinating with Iraqi security services but with our own. For example, we should not have convoys moving around areas that we know to be very violent without some sort of coordination with the military, and that has happened before and that has gotten people into trouble before.

Senator DOLE. General Sanchez, do you want to answer that as well?

General SANCHEZ. Yes ma'am. We are working with the CPA reconstruction effort. We work with all the contractors in the country. We have the mechanisms to provide escort for convoys as they move across the country, and there have been instances where contractors have moved without coordination with the local commanders and without escort and they have gotten themselves in trouble. But we do have the mechanisms and we are continuing to work that with them.

General ABIZAIID. By the way, Senator Dole, if I may, I would just like to add by saying, we sometimes forget that a lot of these contractors who are out there are heroes too.

Senator DOLE. Yes.

General ABIZAIID. They are out there in a very dangerous area. A lot of them—I would say the vast majority of them—are doing it because they love their country. We should not fail to praise them. There are times when we are not happy with the way contracts work, et cetera, but these young Americans and older Americans who are out there doing this are by and large great people who love the country and doing God's work.

Senator DOLE. Thank you for adding that statement. I could not agree with you more. My time has expired.

Chairman WARNER. I would like to also say I thank you very much for the recognition. It is well-deserved by that infrastructure that supports our forces.

We have two remaining Senators, then the committee will stand in recess for just a few minutes and we will resume in room 219, which is in this building.

Senator Bill Nelson.

Senator BILL NELSON. General Miller, I think you cleaned up the situation at Guantanamo. I think you did a good job. Of course, we are trying to sort out other things but I just want that in the record, from my observations, having been there twice.

General Abizaid, yesterday we had Lieutenant General Sharp in front of the Senate Foreign Relations Committee. He offered a little bit of clarity, and perhaps you can help clarify things here for us. Earlier in your testimony you stated that what we are facing, "It's a hard thing, it will take a long time." One of the responsibilities that we have is looking at a force structure. We keep getting different statements that are interpreted different ways. So one of the things that I would like to ask you is, do you consider it part of

the mission in Iraq to disarm the militias, such as the Mehdi army of al-Sadr?

General ABIZAID. I regard al-Sadr's militia right now as being a hostile force and it is our mission to disarm them or destroy them in battle.

Senator BILL NELSON. I would think that would be the common sense thing; if I were the commander that would be part of my mission.

General ABIZAID. But Senator, if I might add, it is also clear that as we move towards a period of partnership in Iraq, which is so essential for us to move to, that those militia forces or armed groups that may belong to people loyal to the new Iraq, that are willing to move forward in a manner of reconciliation and work towards a better future, we need to work with them to integrate them into the system. So it is not that we will go out and destroy all militias, certainly not. It is that we will fight those who are working against us and will work to help integrate those that have worked with us, such as we find in the Kurdish areas and to a certain extent in some of the Shi'ite areas with the Badr Corps.

Senator BILL NELSON. It would be nice if we had an Iraqi army that was ready to do a lot of that. It would be nice if we had a police force that would be able to help us. But at the moment we do not. So I am asking you about your mission now. Does your mission in Iraq include providing security on the streets against crime, functions normally performed by a police force?

General ABIZAID. Our mission in some areas, where the police force is not working, unfortunately causes us to have to do police work. That is correct. It is also correct to say, Senator, that we probably have overstated how bad things are with the Iraqi security forces, that the Iraqi security forces in certain areas of the country are exceptional and they are doing very well. In the north we see it and in some places in the south. There are many police forces that are doing well by Iraqi standards and will continue to do well. We had a failure during the April time frame, as you are well aware, of some units of the Iraqi Civil Defense Corps, of some units of the Army and of some units of the police. But on the other hand, Senator, I believe this has more to do with our willingness to give them authority than it has to do with their willingness to fight for their country. They want to fight for their country but they want to fight for Iraqis. So as we move towards this period of sovereignty and Iraqi chains of command are established that are reliable, I believe that the quality of Iraqi forces will move in a direction that will surprise a lot of people. I have faith in them.

Senator BILL NELSON. I certainly hope so. I visited one of those police academies in Jordan where you are training them, but it is a long time and there are only X thousand that you can prepare. We will find out how many in the future. Since we are having to disarm militias and also having to provide some protection against street crime right now, the question is, is the 105,000 level, augmented by keeping the additional 20,000 so that you are somewhere in the range of 125,000, 130,000 troops, is that sufficient for you to carry out your mission over the course, not only before June 30 but over the rest of the year after June 30?

General ABIZAID. Again, I do not like to waffle in my answers, and this will sound like a waffle to you, but it depends on a couple of different things. It depends upon the enemy, although I would predict, and I think Rick will agree with me, that the situation will become more violent, even after sovereignty, because it will remain unclear what is going to happen between the interim government and elections. So moving through the election period will be violent, and it could very well be more violent than we are seeing today. So it is possible that we might need more forces. But I would again say that perhaps with a resolution in the United Nations could say that instead of international forces withdrawing from Iraq they should come to Iraq, because other nations need to understand how important Iraq's stability is for their future as well as the entire region's future. Getting more international forces and getting a higher quality of Iraqi forces will help us figure out where we stand. But I think the numbers about where we are now for the foreseeable future unless something changes, either international force-wise or in the quality of Iraqi troops, and is what we can expect through the elections.

Senator BILL NELSON. What did you mean by a long time?

General ABIZAID. Well, we know the elections will take place in December or January. So, I am saying that the First Armored—please do not get me in any more trouble with the First Armored Division and the Second Armored Cavalry. We will rotate them out of there but the force levels will stay about what they are, I think, until after the elections. Or until we come to a point where we see that we are going to have a soft landing.

Chairman WARNER. Thank you very much, Senator.

Senator AKAKA.

Senator AKAKA. Thank you very much, Mr. Chairman. I want to add my gratitude to you and praise and commendation for your leadership as well as to our troops in Iraq and Afghanistan. I too have visited Iraq and Afghanistan, and the kind of message I got while I was there was good. Our troops seemed to have been working well at that time.

I have been very concerned about one part of the personnel that is there. We have talked about international and coalition forces, we have talked about the MPs, the MIs. One group is the contractors—this has been mentioned here—and I get the sense, and I would like to get an answer from you on this, that the contractors seem to be outside of the line of command. That is my feeling. As a result some things they do are not known by us.

General Abizaid, it is my understanding that the civilian contractors who are interrogators—there are many different kinds—work directly with MI personnel. My question is, who supervises the civilian interrogators and do they report to any agencies other than the DOD? Another question is, is anyone in the DOD accountable for the behavior the civilian contractors?

General MILLER. Sir, if I could I would like to take this.

Senator AKAKA. General Miller. Thank you.

General MILLER. The civilian contractors who work in our intelligence organizations are accountable to the chain of command of the intelligence organization. So if you are an interrogator you are accountable to the chain of command of the interrogation company

or the battalion or the brigade that goes in there. So there are also people who do screening. By screening I mean when you are captured, they do the initial debriefing to be able to develop intelligence. So we have a small number who are in our Intelligence Fusion Centers. They all work for the military through here. In our organization currently no civilian contractor is at a supervisory position. It is the military who sets the priorities and ensures that we meet our standards.

Senator AKAKA. What other types of personnel do you have there as contractors besides interrogators?

General MILLER. Sir, in the intelligence area there are the screeners, those who get initial information from those under interrogation, and those who are involved in intelligence fusion, developing intelligence from processed intelligence, from raw intelligence and feeding our computer systems. Those are the contractors that we have in the intelligence system.

General ABIZAID. You will also find interpreters, Senator.

Senator AKAKA. Thank you. My question on that is, are there any contractors who are from Third World nations?

General ABIZAID. I am sure there are. Yes, I have talked to some.

General MILLER. Our translators, some of them are from Third World nations. They do an excellent job for us.

Senator AKAKA. Okay. Can you name some of the nations?

General MILLER. Sir, I am sorry, I cannot.

Senator AKAKA. My concern has been—and thank you for answering it—that they are within the line and chain of command so that we know what they are doing and they are answerable to someone in DOD.

General MILLER. Sir, we will, for the record, get the Nations that those interpreters are from.

[The information referred to follows:]

This is in response to your request about the countries whose citizens are working for us as interpreters/translators through the Army's linguist contract. As regards JTF-GTMO, all the linguists there now are U.S. citizens with security clearances, although previously there were some linguists there who did not require a security clearance. At that point we did have non-U.S. citizens there, most notably a Chinese citizen who spoke Uighur; he has since become a U.S. citizen and remains on the island. Due to the high level of proficiency required to support Army missions, many of the linguists working as U.S. citizens in positions that require security clearances are naturalized citizens. Their countries of origin have not specifically been tracked—some of these individuals became U.S. citizens more than 20 years ago while others, such as the Uighur linguist at JTF-GTMO, are very new citizens.

As to the foreign nationals working under the Army linguist contract, the majority of the requirements for linguists who do not require access to classified information are hired locally. We have such linguists hired in Iraq, Afghanistan, Kuwait, Qatar, and Bahrain. OSD funded an effort for linguists without security clearances to be hired from the U.S. and other allied nations with the intent of providing the forces in Iraq with linguists who are not only fluent in the Iraqi dialect of Arabic and knowledgeable of Iraqi customs, but also are familiar with U.S./Western culture. While the majority of the linguists hired through this program are Iraqi citizens who are permanent resident aliens of the U.S., there are also some Canadians of Iraqi descent working for us as linguists. Additionally, there are one or two linguists from Lebanon, Jordan, Egypt, and Italy, all of whom have sufficient proficiency in the Iraqi dialect and English to allow them to support Army missions.

Senator AKAKA. Thank you very much. General Miller, you have had quite a bit of publicity and so let me ask you this out of my curiosity. Did you tell General Karpinski that you were going to "Gitmoize" Abu Ghraib? What did you mean by this statement?

General MILLER. Senator, I did not tell General Karpinski I was going to "Gitmoize" Abu Ghraib. I do not believe I have ever used that term. When Janis Karpinski and I were having our dialogues, they were about humane detention, how the detention centers would be run, the requirements for the MPs and the leadership to be present and ensure that humane detention is done. As we have talked about before, it is an enormously high leader impact, high leader-type requirement.

Senator AKAKA. Do you think it is possible that any of your recommendations could have been misconstrued by the civilian contractors?

General MILLER. Senator, I do not believe that any of those recommendations were misconstrued. At that time there were no civilian contractors employed in the organization. But once again, that would be speculation on my part because I was not there during the hiring to see how the civilian contractors came in.

Senator AKAKA. General Abizaid, you discussed the need to modify Army doctrine about Abu Ghraib, and you cited instances of abuse in Afghanistan and Iraq. Is the problem of detainee abuse systemic within CENTCOM?

General ABIZAID. No sir, I do not believe it is systemic. There have been instances of abuse in Afghanistan and other prisons, and in Iraq as well. I believe my comments concerning doctrine have to do more with how we fuse intelligence, how we distribute intelligence, how we work in a synchronized manner to achieve results that will help our young soldiers and marines on the battlefield.

Senator AKAKA. Thank you very much for your response.

Chairman WARNER. Thank you very much, Senator Akaka.

We have had an excellent hearing, a very thorough exchange of views and responses. We thank you.

Senator Talent.

Senator TALENT. I appreciate the opportunity and if we are going to go in a closed I will withhold my questions. I do have a very brief statement, though. I do want to associate myself with some of the concerns that Senator Inhofe raised. There is so much that you do not know whether you know it or not, and one of the worst things that could happen out of this is if we ended up in a situation where some of these people got off because of something that was said at one of these hearings. In addition, I think there is something to be said for waiting until you all can present the comprehensive results of your investigations. I do want to, just for the record, Mr. Chairman, respectfully suggest to you and the ranking member that we consider whether it would be good to have the Fay Report in hand before we do the next hearing. I know you are talking constantly with the ranking member about timing and what we ought to do, and I think these hearings have been very good. But it almost comports with the Senate schedule anyway, given that a recess is coming up.

Chairman WARNER. Senator, in my discussions with the DOD, which I might say has been very cooperative, they have indicated that this committee will be the first to receive the Fay Report when it is available.

Senator TALENT. If it looks like they are stonewalling on it I think it is a different thing.

Chairman WARNER. No.

Senator TALENT. But you think in a couple of weeks that the report will be available.

Chairman WARNER. The DOD will determine the timing of the release of that report.

Senator TALENT. All right. Thank you, Mr. Chairman.

Chairman WARNER. Again, I thank you very much. We will now go to Hart 219 for a closed session. I thank the committee. I take note that we have had 100 percent attendance here today. I think that speaks to the seriousness and the solemnity with which this committee regards this very serious issue.

Senator LEVIN. Mr. Chairman, I want to thank our witnesses for joining us but also indicate that I have some additional questions that are unclassified that we do not have time to ask.

Chairman WARNER. Right.

Senator LEVIN. I will be submitting those to our witnesses. I think if the chairman would set a deadline for those so our witnesses will not have to be troubled by questions coming in for a long period of time; for instance, questions within the next 24 hours or 48 hours would be very helpful.

Chairman WARNER. Absolutely. Thank you.

Senator LEVIN. Would that be all right?

Chairman WARNER. That would be fine.

Senator LEVIN. Forty-eight hours then?

Chairman WARNER. Let us just establish midday Friday.

Senator LEVIN. That would be fine. Noon Friday?

Chairman WARNER. Noon Friday. Thank you very much.

[Questions for the record with answers supplied follow:]

QUESTIONS SUBMITTED BY SENATOR SUSAN COLLINS

GENERAL TAGUBA'S REPORT

1. Senator COLLINS. General Miller, General Taguba's report stated that the 320th Military Police (MP) Battalion (BN) and the 372nd MP received no training in detention or internee operations prior to deployment to Iraq. I would like your assessment of the training of the MPs at Abu Ghraib prison. Prior to their deployment to Iraq, what was their experience at civilian or military prisons, and once they were mobilized, what training were they provided?

General MILLER. The United States Army Reserve Command could better comment on the exact make up from civilian life of the 320th MP BN. The soldiers and leaders of the 320th MP BN were trained in accordance with the current Department of the Army mobilization requirements. The Department of the Army would better be able to comment on pre-deployment training conducted.

LACK OF TRAINING

2. Senator COLLINS. General Miller, do you believe that a lack of training played a part in the alleged abuse at Abu Ghraib?

General MILLER. I believe it was a breakdown in the fundamentals of leadership within the unit that led to the alleged abuse going unreported. Leaders set the tone by which a unit runs; they imbued the morals and standards of the unit on each individual soldier and junior leader. In this case the leadership failed to do their primary job: to lead.

OTHER U.S.-RUN PRISON FACILITIES

3. Senator COLLINS. General Abizaid, can you give me your assessment on whether abuse similar to that alleged at Abu Ghraib has occurred at other U.S.-run prison facilities in Iraq or Afghanistan?

General ABIZAD. The type of abuse seen in many of the photographs taken at Abu Ghraib appears at this time to be confined to that location and to have occurred during the timeframe of October-November 2003. At other detention facilities there have been isolated incidents of alleged abuse, normally involving the use of excessive and unauthorized physical force. Each of these incidents is currently the subject of review and investigations are ongoing.

INTERNATIONAL COMMITTEE OF THE RED CROSS REPORT

4. Senator COLLINS. Colonel Warren, with respect to the working paper that the International Committee of the Red Cross (ICRC) submitted to the Combined Joint Task Force (CJTF) officials on November 6, 2003 to complain about abuses observed at Abu Ghraib in October, you testified that your "office participated in the drafting of a response for Brigadier General (BG) Karpinski's signature. That response was dated December 24 and would have been delivered to the International Committee of the Red Cross." According to The Wall Street Journal, General Karpinski stated that the first time she learned of the ICRC report was in late November when she was summoned to a meeting with you and General Walter Wojdakowski, where she was told by you "not to worry about the response because his officers were working on the response for my review." When did you first become aware of the November 6 ICRC report, to whom was it addressed, did you read the report, and were you aware of its content?

Colonel WARNER. I first became aware of the report in early December 2003 when I returned to Iraq from leave. I was on leave in Germany from 12-30 November 2003. The report was transmitted by the ICRC cover letter, dated November 12, 2003, addressed to "BG Janice Karpinsky (sic), 800th MP Brigade." General Karpinski's December 24, 2003, response is enclosed.



DEPARTMENT OF THE ARMY
377TH THEATER SUPPORT COMMAND
HEADQUARTERS, 800TH MILITARY POLICE BRIGADE
CAMP VICTORY, IRAQ APO AE 08342

REPLY TO
ATTENTION OF
Commander, 800th Military Police Brigade

24th December 2003

Ms Eva Svoboda
ICRC Protection Coordinator
IRAQ

Dear Ms Svoboda,

ICRC VISITS TO CAMP CROPPER AND ABÚ-GHURAYB IN OCT 03

Introduction

Thank you for your letter dated 12 November 2003 enclosing confidential Working Papers relating to visits to Camp Cropper and Abu Ghurayb in October.

The importance of cooperation between the ICRC and Coalition forces, particularly during ongoing hostilities by those who have no regard at all for protected symbols or institutions, cannot be overstated. Given the difficult conditions under which Coalition forces operate, our mutual interaction helps to ensure every effort is made to uphold the Geneva Conventions. It is our desire all individuals in detention facilities be treated humanely, at all stages of the detention process.

Special Detention Facility (Camp Cropper)

While your Working Paper acknowledges conditions in this facility have continued to notably improve, it claims conditions still contravene internment standards in Geneva Convention III and IV (GCIII and IV). We maintain those detainees who have been classified as Enemy Prisoner of War (EPW) or those awaiting GCIII/5 determination, are being treated in accordance with the principles in GCIII/13. However, there are ongoing efforts to improve their conditions.

With regard to the segregations of High Value Detainee (HVD) EPW/Security Internees, these personnel have been assessed to be of significant ongoing intelligence value to current and future military operations in Iraq. Their detention condition is in the context of ongoing strategic interrogation and imposed local conditions. Under the circumstances, we consider their detention to be humane. When their detention is determined to be no longer necessary due to "imperative reasons of security" and if available evidence does not support prosecution

for crimes, they will be released. Notwithstanding the continuing armed conflict in Iraq, nearly 5% of HVDs have already been released on parole.

Concerning segregations, the issue of cells without daylight is a disciplinary prohibition in GCIII/IV. The HVDs are not held in such conditions as a disciplinary measure, but as a temporary security precaution during their ongoing interrogation and as a result of available appropriate structures. As your paper notes, internees have access to electric lighting, an hour outside their cells each day, and showers.

The alleged ill treatment of Ibrahim Khalil Ibrahim Hussein Al-Aani upon capture will be investigated and appropriate action taken if warranted. U.S. forces make the legal status, rights and judicial guarantees of all detainees a continuing priority in detention operations.

Regarding the treatment of EPWs under GCIII, the matter will be considered and appropriate measures will be implemented if necessary. With respect to the security internees, who are "definitely suspected of or engaged in activities hostile to the security of the State", we agree they are protected persons under GCIV. However, depending on the nature of the security risk presented by these internees, their protections are subject to the derogation pursuant to GCIV/5.

Baghdad Central Detention Facility (Abu Ghurayb)

It is regretted there were difficulties with access to detainees on 21 October 03. Improved procedures should ensure such problems are avoided in the future.

The security environment around Abu Ghurayb is challenging, like many areas in Iraq. Steps are continually being taken to improve security by engaging those launching attacks on the facility. Shelters against mortar or rocket attack are in shortage throughout the country for Coalition forces as well, but may be provided to the facility in due course. There is no threat of air attack.

Concerning the interrogation of security internees, the questioning of a small number of internees selected for their significant intelligence value in Unit 1A is a military necessity. Our forces follow clear procedures governing interrogation to ensure approaches do not amount to inhumane treatment. As internees in Unit 1A undergo interrogation, they may be segregated for security purposes for the period of interrogation. Their right to communication may also be infringed for "absolute security" reasons as contemplated in GCIV/5.

With regard to the criminal detainees in the common law sections, recreational activities should improve over time, as should family visits for this category of detainee. Despite obvious military security issues with respect to communication by security internees, means to allow family visits and other types of communication for these internees are being reviewed in order to balance humanitarian and security considerations. The rioting and shooting of a U.S. guard last month by a security internee using a pistol smuggled into the facility is a

timely example of the need to ensure proper security measures are taken throughout the facility.

Improvement can be made for the provision of clothing, water and personal hygiene items. Efforts are ongoing to make continued improvements in these areas. As with the HVD facility, improvements are continually being made with regard to procedures relating to judicial guarantees.

Conclusion

The two Working Papers provided should offer great assistance in understanding how our detention operations are conducted in accordance with the Geneva Conventions. However, security conditions during this armed conflict do present challenges delaying certain improvements in the detention conditions of all classes of detainees. As security in Iraq improves, more resources can be devoted to further improving the conditions in detention facilities. Our aim is to continue providing for the security and humane treatment of all detainees. However, as you will have noted, while the armed conflict continues, and where "absolute military security so requires" security internees will not obtain full GC protection as recognized in GCIV/5, although such protection will be afforded as soon as the security situation in Iraq allows it.

In the meantime, in the context of ongoing operational and strategic interrogation of certain security internees, locally imposed conditions and resource constraints, all internees are guaranteed humane treatment as a minimum standard. We will seek to exceed this standard where possible and appropriate. Your input is important, and we look forward to a positive ongoing working relationship with ICRC delegates in the future.

Sincerely,



JANIS L. KARPINSKI
Brigadier General
Commanding

5. Senator COLLINS. Colonel Warren, did you personally approve your office's response to the ICRC report? What actions did your office take to inquire into the validity of these ICRC alleged abuses?

Colonel WARREN. I approved the proposed response provided to the 205th MP Brigade (BDE). In my absence in late November, my section conducted an analysis of the report, which it provided to the Commander, 800th MP BDE and CJTF-7 C-2 by transmittal memorandum, dated November 27, 2003.

Judge Advocates from my section met with officers from the 205th Military Intelligence (MI) BDE and the 800th MP BDE in order to inquire into the validity of the reported abuses. Through this process, Judge Advocates were continually assured that the accusations were baseless. Judge Advocate General Corps (JAGC) officers responsible for ICRC liaison attended a meeting with the ICRC on November 16, 2003, at which the report was discussed and a meeting at Abu Ghraib with the MPs and MI personnel on December 4, 2003, called for the purpose of discussing the report. I personally discussed the allegations of the report with MI and MP personnel present at a Coalition Provisional Authority (CPA) Prison Meeting in December. I also personally discussed the allegations with the Judge Advocate of the 205th MI BDE, who was present at Abu Ghraib. The unanimous reaction of all military personnel with whom I talked was that the allegations were implausible and not credible or exaggerated.

6. Senator COLLINS. Colonel Warren, what was BG Karpinski's role in the drafting and approval of the response? Did she sign the response to the ICRC? At that time, was it normal procedure for your office to draft responses to ICRC reports?

Colonel WARREN. BG Karpinski signed the response, dated December 24, 2003. Notice of the report was provided to her command in late November, while I was on leave. A draft response was formulated in concert with her command and the 205th MI BDE and was provided to her office in mid-December. I understand that changes were made to the draft by the BDE during the coordination process before it was prepared in final for her signature. To the best of my knowledge, this was the first time that my office drafted a response to an ICRC report.

There was no normalized procedure for handling ICRC reports and responses. Until January 2004, there was no clear delineation of responsibility for receipt of, and response to, ICRC reports in Iraq. This is because the 800th MP BDE, a Coalition Forces Land Component Command (CFLCC) unit, had operated the Enemy Prisoner of War (EPW) facility at Camp Bucca since the beginning of the war and had an established and continuing relationship with the ICRC.

My section became involved in the ICRC visits to detention facilities in late May 2003. This involvement consisted of attendance at some portion of the inspection visits, typically the in and out-briefs, and reviewing copies of the reports. Meetings at the ICRC Baghdad headquarters were attended by officers from the 800th MP BDE and CJTF-7 Judge Advocates. At these meetings, my officers or I would receive copies of ICRC reports and I was added as a courtesy copy addressee on most correspondence. Until January 2004, when the process was changed at the direction of Lieutenant General Sanchez, I believe that all original reports were addressed to the 800th MP BDE (either to BG Karpinski or to the camp [battalion] commander). The process, as explained to me by an ICRC delegate, was such that these reports (termed "Working Papers") were to be handled at the lowest level possible, typically one level up from the camp commander, and a written response was neither required nor expected by the ICRC. Rather, the ICRC would use the report content as a basis to assess corrective action in subsequent visits to the camp at issue.

7. Senator COLLINS. Colonel Warren, what other responses to the ICRC did your office participate in drafting or reviewing prior to that time?

Colonel WARREN. To the best of my knowledge, the December 24, 2003, response was the first written response to a camp visit drafted by my section. Previously, my section drafted and reviewed correspondence to and from Lieutenant General Sanchez. A summary of correspondence with the ICRC is enclosed. While I believe this summary to be complete, it is possible that documents have been lost in the past 16 months of combat operations.

SUMMARY OF LTG SANCHEZ' RESPONSES TO ICRC REPORTS

(Q. 7)

-- **20 July 2003**, Letter from COL Marc Warren on behalf of LTG Sanchez to Ms. Kasandra Vartell, ICRC, prepared regarding the correspondence sent to LTG Sanchez on 16 July 2003 verifying that an investigation into an alleged incident was underway.

-- **6 September 2003**, LTG Sanchez responds via a letter to the ICRC letter to him dated 17 August 2003 concerning notification to the ICRC of information pertaining to protected persons.

-- **21 April 2004**, LTG Sanchez responds via a letter to Mr. Anthony Dalziel (ICRC) regarding the letter he wrote on 16 April 2004, regarding respect for international and humanitarian law.

8. Senator COLLINS. Colonel Warren, who in your chain of command did you inform of the substance of the report? Did you inform General Sanchez, and if so, when?

Colonel WARREN. I do not recall personally informing any superior officers in my chain of command of the report transmitted by letter of November 12, 2003, until January 2003. When I returned from leave, I learned that the report was being staffed within the command for a response. I do not recall discussing the detailed substance of the report with Lieutenant General Sanchez until February 2004.

9. Senator COLLINS. Colonel Warren, when you learned of the report, what actions, if any, did you personally take to inquire into the validity of the ICRC alleged abuses?

Colonel WARREN. Please see my response to question number 5.

10. Senator COLLINS. Colonel Warren, what corrective actions, if any, were taken in response to the report? Please provide the CJTF-7 response to the ICRC report.

Colonel WARREN. For specific corrective actions on conditions of detention, I must refer you to the 800th MP BDE. For general conditions of the Abu Ghraib base camp after November 19, 2003, and for all matters pertaining to interrogation operations, I must refer you to the 205th MI BDE. As to corrective actions on ICRC access beginning in January 2004, officers from the CJTF-7 headquarters coordinated and attended future visits. This approach was implemented for the next ICRC visit to Abu Ghraib, which occurred during the period of January 4-8, 2004, and was the subject of positive comment by ICRC delegates. In its report on the January 4-8, 2004, visit, the ICRC commented on improvements at Abu Ghraib made since their October visit. Also in January 2004, the ICRC was informed that reports should be addressed to the commander, CJTF-7 and provided to me or one of my officers.

There was no CJTF-7 response to the October 2003 report. The response provided to the ICRC was from the Commander, 800th MP BDE.

CJTF INTERROGATION POLICY

11. Senator COLLINS. Colonel Warren, could you confirm that: CJTF had not issued official interrogation policy guidance prior to September 14, 2003; the September 14, 2003 interrogation policy was subsequently determined to be noncompliant with the Geneva Conventions; and this determination led to the issuance of new guidance on October 12, 2003?

Colonel WARREN. It is correct that CJTF-7 had not issued official interrogation policy guidance prior to September 14, 2003. It is not correct that the September 14, 2003, interrogation policy was subsequently deemed to be noncompliant with the

Geneva Conventions. However, it is accurate that legal analysis conducted within CJTF-7 and U.S. Central Command (CENTCOM) contributed to the decision to issue the more conservative October 12, 2003, policy.

12. Senator COLLINS. Colonel Warren, did any of the alleged detainee abuses that have come to light occur during the period prior to September 14, 2003? If so, please describe the nature of these alleged abuses.

Colonel WARREN. To the best of my knowledge, none of the detainee abuses that came to light in the U.S. Criminal Investigation Division Command (USACIDC) Investigation or the Army Regulation 15-6 Investigation conducted by Major General (MG) Taguba concerning Abu Ghraib occurred prior to September 14, 2003. It is possible, however, that cases of abuse that occurred prior to that date will come to light in the course of MG Fay's investigation. I believe that the chronology of any cases of abuse will be part of the report of investigation by MG Fay.

13. Senator COLLINS. Colonel Warren, did any of the alleged detainee abuses that have come to light occur during the period between September 14 and October 12, 2003? If so, please describe the nature of these alleged abuses.

Colonel WARREN. To the best of my knowledge, two incidents of detainee abuse occurred at Abu Ghraib between September 14 and October 12, 2003. I believe that the first was an allegation of rough treatment of an Iraqi male suspected of mortar attacks. The second was an incident in which three MI soldiers were punished under Article 15, Uniform Code of Military Justice (UCMJ), for improper association with a female detainee (violation of policy). It is possible, however that additional cases of abuse that fall within that time period will come to light in the course of MG Fay's investigation.

14. Senator COLLINS. Colonel Warren, what categories of persons (e.g., prisoners of war (POWs), detainees, etc.) were covered by the September 14, 2003 interrogation policy and the October 12, 2003 interrogation policy?

Colonel WARREN. The September 14, 2003, policy covered both categories and distinguished the two. The October 12, 2003, policy applies by its terms only to civilian security internees.

MILITARY INTELLIGENCE

15. Senator COLLINS. Colonel Warren, is it true that MI operations at Abu Ghraib detention facility and other detention facilities in Iraq were conducted by MI units that had prior experience in Afghanistan, where the administration determined the Geneva Conventions did not apply?

Colonel WARREN. I understand that at least one MI unit (A Company, 519th MI BN) and selected soldiers from other units had prior experience in Afghanistan. My understanding of the U.S. Government's position on the application of the Geneva Conventions in Afghanistan is that they did not apply to the conflict with al Qaeda. Regardless, as a matter of policy, the U.S. forces treat all detainees humanely and, to the extent appropriate and consistent with military necessity, in a manner consistent with the principles of Geneva Conventions.

16. Senator COLLINS. Colonel Warren, in the absence of any interrogation policy guidance from CJTF-7 prior to mid-September 2003, are you concerned that those units might have utilized the interrogation rules that had been in effect in Afghanistan?

Colonel WARREN. Yes. This is one reason why CJTF-7 issued the policy that culminated in the October 12, 2003, memorandum.

QUESTIONS SUBMITTED BY SENATOR CARL LEVIN

HIGH VALUE DETAINEES

17. Senator LEVIN. General Abizaid, you have confirmed that the high value detainees at Camp Cropper fall under the responsibility of General Dayton, commander of the Iraq Survey Group (ISG), who reports directly to you. You also confirmed that the high value detainees were put under General Dayton as a result of a decision in Washington to have a better and more efficient way to understand what was going on with respect to weapons of mass destruction. General Sanchez testified that his MPs have responsibility for providing security. Who in Washington was involved in this decision?

General ABIZAID. The decision to establish the ISG involved appropriate members of the Joint Staff, the Office of the Secretary of Defense (OSD), the Defense Intelligence Agency (DIA), and the Central Intelligence Agency (CIA). The ISG is a unique organization designed to explore the linkage between weapons of mass destruction (WMD) and the former regime leadership. Its establishment required close coordination and careful consideration.

18. Senator LEVIN. General Abizaid, is there a division in the chain of command for the high value detainees at Camp Cropper, with the detention and interrogation of the high value detainees under one chain of command and the protection and security of those detainees under another chain of command?

General ABIZAID. During the period in question, there was a division between responsibility for the detention facility and its security and responsibility for the interrogation of high value detainees (HVDs) at Camp Cropper. As the CJTF-7 Commander, LTG Sanchez was responsible for the Camp Cropper detention facility: its security; operations and maintenance; and disposition/protection of all resident HVDs. The Director, ISG, in compliance with modification 3 to the ISG execute order (EXORD), dated October 17, 2003, conducted interrogations and debriefings of HVDs resident at Camp Cropper in order to acquire information in direct support of ISG's unique mission: organize, direct and apply capabilities and expertise in Iraq to discover, take custody of, and exploit information and material of intelligence value on individuals and methods within the following three areas: weapons of mass destruction, counterterrorism, and the fate of Captain Michael Scott Speicher.

19. Senator LEVIN. General Abizaid, who were the sources of the decision that there be dual chains of command and for what reason?

General ABIZAID. The original EXORD, dated May 31, 2003, directed Commander, CENTCOM, to coordinate with the Director, DIA, to stand up the ISG in order to accomplish national objectives in Iraq. This EXORD clearly stated that the ISG would generate its own taskings and that its priorities would be highly responsive to national requirements. The command relationships reflected in the original EXORD had the ISG operational control to the CJTF-7. In modification number one to that EXORD, dated June 20, 2003, the Secretary of Defense directed a change to the command relationships making ISG operational control to CENTCOM.

The ISG is a unique organization, reporting to both Commander, CENTCOM and the DIA with strategic direction from the CIA. The specialized mission and requirements of the ISG demanded unique management, to include a direct link to the Department of Defense (DOD) for time sensitive permissions and authorities, as well as consistent alignment with national objectives. I believe this change in command relationships was designed to reflect the relative independence and unique mission of the ISG.

20. Senator LEVIN. General Abizaid, in your personal view, is it wise to focus so much on WMD when the HVDs might have information that could be valuable in the day-to-day effort to protect U.S. and coalition forces?

General ABIZAID. At the time of the establishment of the ISG, the need to immediately locate and disable any possible Iraqi WMD was one of the highest national priorities. While ISG interrogations were focused on WMD, counterterrorism, and the fate of Captain Speicher, these were not the only topics addressed. Standing operating procedure (SOP) in the ISG required that all captured persons were immediately interrogated or debriefed for all actionable intelligence, to include force protection information.

The mission of the ISG is currently under re-evaluation. I agree that intelligence assets, already in short supply throughout the theater, need proper focus and constant re-tasking to meet changing requirements. Currently, counterterrorism and counterinsurgency requirements are theater-wide priorities.

21. Senator LEVIN. General Abizaid, what benefit do you see in the command relationship that seems to violate the tenet of unity of command?

General ABIZAID. The ISG, because of its unique mission, organizational structure and technical areas of expertise, had a dual reporting chain to CENTCOM and the DIA. Unity of command was not affected by this reporting relationship. Command and control remained under CENTCOM operational control, with close coordination with CJTF-7. This reporting relationship, which affected collection and exploitation priorities, merely allowed more rapid access to strategic information of value to national level policymakers.

22. Senator LEVIN. General Abizaid, do the CJTF-7 October 12, 2003 interrogation policy guidelines apply to those HVDs? If not, why not? What interrogation policy applies? Please provide a copy of the interrogation policy for these HVDs.

General ABIZAID. The ISG promulgated its own interrogation SOP on October 3, 2003. ISG had no command and control relationship to CJTF-7 and its SOP predated the CJTF-7 October 12, 2003, policy guidelines. Consequently, the original ISG SOP did not follow the October 12, 2003, interrogation policy guidelines of CJTF-7. The ISG interrogations SOP was updated in May 2004 and now includes by reference the October 12, 2003, CJTF-7 interrogations policy memo. Both the October 3, 2003, and current ISG interrogations SOPs are classified at the SECRET level.

MEETINGS WITH ICRC OFFICIALS

23. Senator LEVIN. General Abizaid and General Sanchez, the February 2004 ICRC report makes clear that since the beginning of the conflict in Iraq, the ICRC regularly brought concerns about the ill-treatment of detainees to the attention of coalition forces. Additionally, Secretary Powell has stated that he met with ICRC President Jacob Kellenberger three times since the beginning of 2003 and they discussed the treatment of detainees, including in Iraq. Secretary Powell advised that Mr. Kellenberger raised this matter in meetings with the Pentagon and with National Security Advisor Condoleeza Rice over the same time period. Did any senior administration officials contact you with concerns about the treatment of detainees in Iraq following their meetings with Mr. Kellenberger or any other ICRC official?

General ABIZAID. I do not recall being contacted by any senior administration officials following their meetings with Mr. Kellenberger or any other ICRC representatives.

General SANCHEZ. No.

24. Senator LEVIN. General Abizaid and General Sanchez, which officials contacted you, when did they do so, and what was the nature of their concerns?

General ABIZAID. I do not recall being contacted by any senior administration officials following their meetings with Mr. Kellenberger or any other ICRC representatives.

General SANCHEZ. No officials contacted me.

25. Senator LEVIN. General Abizaid and General Sanchez, were any investigations, changes in policy, or other actions undertaken following the ICRC's meetings with administration officials?

General ABIZAID. I do not recall being contacted by any senior administration officials following their meetings with Mr. Kellenberger or any other ICRC representatives and am unaware of any investigations, changes in policy or other actions that may have resulted from those meetings.

General SANCHEZ. I am not aware of any ICRC meetings with administration officials. If those meetings took place, I am not aware of any investigations, changes in policy or other actions being initiated as a result of those meetings.

26. Senator LEVIN. General Abizaid and General Sanchez, did either of you keep senior administration officials informed of the ICRC's concerns about the ill-treatment of prisoners? If so, at what level and on what occasions were they informed?

General ABIZAID. I do not recall contacting any senior administration officials concerning ICRC concerns during the period in question. The ICRC provided its reports on a confidential basis which were designed for issue resolution at the lowest possible level. As I testified during the hearing, at the time in question, ICRC reports were not ordinarily surfaced all the way up through the chain of command.

General SANCHEZ. I had no communication with senior administration officials concerning the ICRC.

The ICRC provided confidential reports which were designed for issue resolution at the lowest level possible. The ICRC Working Papers regarding the ICRC October were enclosed in a November 12, 2003, letter from the ICRC to BG Karpinski, commander of the 800th MP BDE. Those concerns were examined by the 800th MP BDE in concert with CJTF-7 Judge Advocate, C2 (Intelligence), and Provost Marshal's Office. Brigadier General Karpinski provided a December 24, 2003, response.

As soon as information about the detainee abuse reached my level in January 2004, a criminal investigation was initiated. A command-directed investigation (the Major General Taguba investigation) quickly followed. This information about the abuse was provided to higher levels in the military chain of command immediately.

Starting in March 2004, my command prepared a periodic, typically a weekly, report of "detainee abuse" cases that was provided to the Office of the Judge Advocate General of the Army.

27. Senator LEVIN. General Abizaid and General Sanchez, were any investigations, changes in policy, or other actions undertaken as a result of your meetings with the ICRC or receipt of ICRC reports?

General ABIZAID. ICRC reports and concerns were normally handled at the CJTF-7 level and generally resulted in locally improved conditions. I will defer to LTG Sanchez to provide more details on any actions taken.

General SANCHEZ. Yes. The improvement in conditions at detention facilities was a mutual goal of the ICRC and the command. Although not taken solely as a result of ICRC meetings and reports, many improvements did address observations of the ICRC. Particularly during the period April through fall 2003, improvements in shelter, food, clothing, showers, medical care, sanitation facilities, segregation of categories of prisoners, hygiene items, and overall quality of life were made in all detention facilities, most noticeably Camp Cropper and, later, Abu Ghraib. ICRC complaints about overcrowding were addressed by closing Camp Cropper as a Corps Holding Area.

ICRC observations about family notification led directly to the decision to produce Arabic language prisoner lists in the fall of 2003 and distribution of the lists to Civil-Military Operations Centers and, through the CPA, to Iraqi authorities. ICRC observations also led to the posting of names of detainees on the CPA Web site. ICRC observations about family access contributed to the decision to open a visitor's center at Abu Ghraib and Camp Bucca with detainees allowed two visits per month. Additionally, in the absence of a reliable mail system, CJTF-7 continued to personally deliver "Capture Cards" to the ICRC.

ICRC complaints about access difficulties during the October visit to Abu Ghraib led to the decision of CJTF-7 to provide dedicated officers to future ICRC visits to ensure that the ICRC delegates were properly accommodated. This was implemented in the January 2004 visit to Abu Ghraib and was the subject of positive comments by the ICRC. Specific complaints about ICRC access to HVDs were resolved when access was allowed starting in May 2003. Specific complaints about access to eight internees at Abu Ghraib, to whom private visitation had been temporarily denied during the January 2004 visit, were resolved when the ICRC was allowed private interviews with seven of the internees in March and the eighth internee in April. (In January, the ICRC was denied private interviews of eight individuals undergoing active interrogation, but allowed to see the internees, observe the conditions of detention, and obtain the individuals' names and internee serial numbers).

ICRC complaints about rough treatment of persons at the point of capture or in detention were addressed by the publication of command policy memoranda and orders. These include:

- Issuance of interrogation policies in September and October 2003, and May 2004 reiterating the application of the Geneva Conventions and requiring that all interrogations be conducted in a lawful and humane manner, with command oversight.
- Issuance of a memorandum in October 2003 titled "Proper Treatment of Iraqi People During Combat Operations," and reissued on January 16, 2004, after learning about the events that had taken place at Abu Ghraib.
- Issuance of the "Rules for Proper Conduct in Combat" memorandum, partly in response to the ICRC's February report. A draft of the rules was provided to the ICRC for review and comment prior to publication.

ICRC complaints about legal process were addressed through implementation in the summer of 2003 of a requirement that a Magistrate review detentions within 72 hours of induction in a detention facility, service of internment orders and notice of opportunities to appeal, and initiation of both Criminal Detainee Release and Security Internee Review and Appeal Boards in August 2003. Complaints about legal status determination of HVDs were addressed by holding tribunals convened under Article 5, Third Geneva Convention, in the summer of 2003.

ICRC complaints about availability of medical treatment were addressed through increased availability of both dental care and elective surgery and continuing planning for a hospital dedicated to the care of detainees, with provision for intensive care needs and surgery requirements. Services will include emergency physicians, an optometrist, and preventive medicine. Capabilities will include a primary care clinic, pharmacy, laboratory, x-ray capability, rehabilitation capability with an occu-

pational therapist and physical therapist, a prosthetics unit, medical record keeping unit, and respiratory care unit.

The command has centralized the command and control of detainee operations under a Deputy Commanding General, Detainee Operations. One of the goals of this reorganization is to improve the conditions and processes of detention, a mutual goal of the command and the ICRC. Detention Operations is:

- Reviewing the entire process of notifications of detainee deaths and family retrieval of remains with a view towards consistency, efficiency, and responsiveness.
- Reforming the processing of detainee medical records to consolidate record keeping.
- Providing guidance to units to further preventative medicine efforts and arrange for relocation of detainees from the vicinity of areas with standing water.
- Promulgating special training to medical staff for screening of detainee abuse, to include informing detainees that there would be no retaliation for reporting abuse.
- Monitoring food service upgrades to ensure improved conditions for detainees with diabetes. Further nutritional care is to be made available through the detainee hospital.
- Reviewing issues associated with the rapid turnover of medical personnel to ensure proper medical treatment.
- Ensuring emplacement of sandbags around detainees' tents, as well as concrete bunkers for protection against mortars.

Detention Operations has taken steps to relieve over-crowding and ensure cleanliness of camps. Current planning includes climate controlled living facilities. All detainees are issued cots, mattresses, and pillows. Food quality has been improved. Ice is now available on a daily basis. Detainee holding areas now have "pea gravel" in place to hold dust down. A mail system is now in place for detainees. Detainee compound leaders now meet weekly with battalion commanders to discuss detention issues. There is improved accountability and security of detainees' personal property.

ABU GHRAIB VISITS BY ICRC

28. Senator LEVIN. General Sanchez, the February 2004 report of the ICRC describes a mid-October 2003 ICRC visit to Unit 1A of the Abu Ghraib correctional facility. It states that in the course of that visit, ICRC delegates witnessed, among various methods used to secure the cooperation of detainees, the practice of "keeping [detainees] completely naked in totally empty concrete cells and in total darkness, allegedly for several consecutive days." Upon demanding an explanation from authorities at the facility, the ICRC delegates were told by the MI officer in charge of the interrogation that "this practice was 'part of the process.'" [Emphasis added.] The ICRC expressed their concerns about the Abu Ghraib correction facility in a November 6, 2003, working paper submitted to CJTF-7 officials. Who received the November 6, 2003, ICRC working paper?

General SANCHEZ. The November 6, 2003, ICRC working paper was transmitted by ICRC letter dated November 12, 2003, and delivered by the ICRC to an officer of the CJTF-7 Staff Judge Advocate's office on November 16, 2003. It was addressed to the Commander, 800th MP BDE.

29. Senator LEVIN. General Sanchez, was there a "process" in effect at Abu Ghraib facility in October 2003 by which detainees would be segregated and deprived of light and clothing for days at a time, in order to secure their cooperation in interrogations?

General SANCHEZ. Not to my knowledge. Such a "process" would have violated the CJTF-7 Interrogation and Counter-Resistance Policies, as well as command policies that mandate the treatment of all Iraqis, including prisoners and detainees, with dignity, respect, and humanity. (See, for example, the October 5, 2003, policy memorandum, Subject: Proper Treatment of the Iraqi People During Combat Operations, which is enclosed.)



REPLY TO
ATTENTION OF

HEADQUARTERS
COMBINED JOINT TASK FORCE SEVEN
BAGHDAD, IRAQ
APO AE 09338

CJTF7-CG

5 October 2003

MEMORANDUM FOR All Coalition Forces Personnel

SUBJECT: Proper Treatment of the Iraqi People During Combat Operations

1. **Purpose.** This memorandum reemphasizes the responsibility of Coalition Forces to treat all persons under their control with dignity and respect. It reinforces the obligation of Coalition personnel to comply with the law of war.
2. **Humane Treatment of the Iraqi People.** Coalition Forces are committed to restoring the human rights of Iraqi civilians and the rule of law. We must treat all civilians with humanity, dignity, and respect for their property and culture. Coalition Forces preserve human life by avoiding civilian casualties and rendering prompt medical attention to persons injured during combat operations. In all circumstances, treat those who are not taking an active part in hostilities, including prisoners and detainees, humanely. Remain particularly aware of sensitivity concerning females. Whenever possible, females will be searched in a non-public location; unless absolutely necessary, male soldiers will not search females.
3. **Force Protection and the Lawful Use of Force.** We are conducting combat operations in a complex, dangerous environment. Coalition Forces must remain bold and aggressive, yet disciplined, in their use of force. When in contact with the enemy, use only that force necessary to accomplish the mission while minimizing unintended damage. Our posture must be strong and determined, while remaining firmly in control of the destructive power of our weapons. You have learned the principles of the law of war throughout your military careers. As professional soldiers, you must follow them, and comply with the rules of engagement. Before engaging any target, you must be reasonably certain that it is a legitimate military target. Self-defense is always authorized.
4. **Conclusion.** Respect for others, humane treatment of persons not taking part in hostilities, and adherence to the law of war and rules of engagement is a matter of discipline and values. It is what separates us from our enemies. I expect all leaders to reinforce this message.

RICARDO S. SANCHEZ
Lieutenant General, USA
Commanding

30. Senator LEVIN. General Sanchez, did you approve the use of these practices at Abu Ghraib or other detention facilities in Iraq?

General SANCHEZ. I never approved these practices at Abu Ghraib or any other detention facility within my command. Over a 7-month period, I approved approximately 25 requests for segregation in excess of 30 days. Subject to safeguards, segregation from the general detainee population was authorized for up to 30 days for the purpose of security and to prevent collusion of persons believed to possess significant intelligence information. Requests for segregation in excess of 30 days had to be approved by me on an exceptional basis. I did not approve the deprivation of light and clothing. This is not authorized under the CJTF-7 Interrogation and Counter-Resistance Policy.

31. Senator LEVIN. General Sanchez, would such a “process” be consistent with the interrogation guidelines issued by CJTF-7, either on September 14 or October 12, 2003?

General SANCHEZ. Absolutely not.

32. Senator LEVIN. General Sanchez, when were the ICRC working paper and concerns about this “process” or these practices brought to your attention?

General SANCHEZ. The existence of the ICRC working paper was brought to my attention in mid-January 2004 during the same timeframe that the CID investigation and the Army Regulation 15-6 investigation were initiated. I learned of the specific contents of the ICRC Working Papers for visits in October 2003 in February 2004 during an update on the status of the ongoing Abu Ghraib investigations.

33. Senator LEVIN. General Sanchez, was the November 6, 2003, working paper provided to General Karpinski?

General SANCHEZ. Yes.

34. Senator LEVIN. General Sanchez, did CJTF-7 ever recommend the establishment of a “give-and-take policy” at Abu Ghraib facility in order to improve the effectiveness of interrogation operations? If so, was such a policy established based on the recommendations of the Miller report?

General SANCHEZ. I have no knowledge of a “give-and-take policy.”

35. Senator LEVIN. General Sanchez, at the May 19 hearing, there was discussion of a December 24, 2003 letter, which members of your staff helped to prepare, in response to the ICRC November report. Please provide the committee a copy of that December 24 letter.

General SANCHEZ. A copy of the letter is enclosed.

UNCLASSIFIED//FOR OFFICIAL USE ONLY



DEPARTMENT OF THE ARMY
 377TH THEATER SUPPORT COMMAND
 HEADQUARTERS, 800TH MILITARY POLICE BRIGADE
 CAMP VICTORY, IRAQ APO AE 09342

REPLY TO
 ATTENTION OF
 Commander, 800th Military Police Brigade

24th December 2003

Ms Eva Svoboda
 ICRC Protection Coordinator
 IRAQ

Dear Ms Svoboda,

ICRC VISITS TO CAMP CROPPER AND ABU-GHURAYB IN OCT 03

Introduction

Thank you for your letter dated 12 November 2003 enclosing confidential Working Papers relating to visits to Camp Cropper and Abu Ghurayb in October.

The importance of cooperation between the ICRC and Coalition forces, particularly during ongoing hostilities by those who have no regard at all for protected symbols or institutions, cannot be overstated. Given the difficult conditions under which Coalition forces operate, our mutual interaction helps to ensure every effort is made to uphold the Geneva Conventions. It is our desire all individuals in detention facilities be treated humanely, at all stages of the detention process.

Special Detention Facility (Camp Cropper)

While your Working Paper acknowledges conditions in this facility have continued to notably improve, it claims conditions still contravene internment standards in Geneva Convention III and IV (GCIII and IV). We maintain those detainees who have been classified as Enemy Prisoner of War (EPW) or those awaiting GCIII/5 determination, are being treated in accordance with the principles in GCIII/13. However, there are ongoing efforts to improve their conditions.

With regard to the segregations of High Value Detainee (HVD) EPW/Security Internees, these personnel have been assessed to be of significant ongoing intelligence value to current and future military operations in Iraq. Their detention condition is in the context of ongoing strategic interrogation and imposed local conditions. Under the circumstances, we consider their detention to be humane. When their detention is determined to be no longer necessary due to "imperative reasons of security" and if available evidence does not support prosecution

for crimes, they will be released. Notwithstanding the continuing armed conflict in Iraq, nearly 5% of HVDs have already been released on parole.

Concerning segregations, the issue of cells without daylight is a disciplinary prohibition in GCIII/IV. The HVDs are not held in such conditions as a disciplinary measure, but as a temporary security precaution during their ongoing interrogation and as a result of available appropriate structures. As your paper notes, internees have access to electric lighting, an hour outside their cells each day, and showers.

The alleged ill treatment of Ibrahim Khalil Ibrahim Hussein Al-Aani upon capture will be investigated and appropriate action taken if warranted. U.S. forces make the legal status, rights and judicial guarantees of all detainees a continuing priority in detention operations.

Regarding the treatment of EPWs under GCIII, the matter will be considered and appropriate measures will be implemented if necessary. With respect to the security internees, who are "definitely suspected of or engaged in activities hostile to the security of the State", we agree they are protected persons under GCIV. However, depending on the nature of the security risk presented by these internees, their protections are subject to the derogation pursuant to GCIV/5.

Baghdad Central Detention Facility (Abu Ghurayb)

It is regretted there were difficulties with access to detainees on 21 October 03. Improved procedures should ensure such problems are avoided in the future.

The security environment around Abu Ghurayb is challenging, like many areas in Iraq. Steps are continually being taken to improve security by engaging those launching attacks on the facility. Shelters against mortar or rocket attack are in shortage throughout the country for Coalition forces as well, but may be provided to the facility in due course. There is no threat of air attack.

Concerning the interrogation of security internees, the questioning of a small number of internees selected for their significant intelligence value in Unit 1A is a military necessity. Our forces follow clear procedures governing interrogation to ensure approaches do not amount to inhumane treatment. As internees in Unit 1A undergo interrogation, they may be segregated for security purposes for the period of interrogation. Their right to communication may also be infringed for "absolute security" reasons as contemplated in GCIV/5.

With regard to the criminal detainees in the common law sections, recreational activities should improve over time, as should family visits for this category of detainee. Despite obvious military security issues with respect to communication by security internees, means to allow family visits and other types of communication for these internees are being reviewed in order to balance humanitarian and security considerations. The rioting and shooting of a U.S. guard last month by a security internee using a pistol smuggled into the facility is a

timely example of the need to ensure proper security measures are taken throughout the facility.

Improvement can be made for the provision of clothing, water and personal hygiene items. Efforts are ongoing to make continued improvements in these areas. As with the HVD facility, improvements are continually being made with regard to procedures relating to judicial guarantees.

Conclusion

The two Working Papers provided should offer great assistance in understanding how our detention operations are conducted in accordance with the Geneva Conventions. However, security conditions during this armed conflict do present challenges delaying certain improvements in the detention conditions of all classes of detainees. As security in Iraq improves, more resources can be devoted to further improving the conditions in detention facilities. Our aim is to continue providing for the security and humane treatment of all detainees. However, as you will have noted, while the armed conflict continues, and where "absolute military security so requires" security internees will not obtain full GC protection as recognized in GCIV/5, although such protection will be afforded as soon as the security situation in Iraq allows it.

In the meantime, in the context of ongoing operational and strategic interrogation of certain security internees, locally imposed conditions and resource constraints, all internees are guaranteed humane treatment as a minimum standard. We will seek to exceed this standard where possible and appropriate. Your input is important, and we look forward to a positive ongoing working relationship with ICRC delegates in the future.

Sincerely,



JANIS L. KARPINSKI
Brigadier General
Commanding

36. Senator LEVIN. General Abizaid, when were the ICRC working paper and concerns about the practices described above brought to your attention?

General ABIZAID. I did not become aware of the contents of the November 6, 2003, working papers until shortly before I prepared for my testimony before the Senate Armed Services Committee.

37. Senator LEVIN. General Abizaid, did General Sanchez, or anyone else, alert you to ICRC concerns about the treatment of detainees at the Abu Ghraib prior to January 2004?

General ABIZAIID. I did not become aware of the contents of reports authored by the ICRC until shortly before I prepared for my testimony before the Senate Armed Services Committee. Historically, the ICRC determines at what level they would like to air their concerns and views their communications as confidential. The ICRC exercises their prerogative to address officials at the level they deem appropriate. It has been our practice in the CENTCOM area of responsibility (AOR) to address the ICRC's concern at the level of command to which they were raised. I have since changed that practice and directed that copies of ICRC reports be forwarded through the chain of command to me.

QUESTIONS SUBMITTED BY SENATOR EDWARD M. KENNEDY

ICRC VISITS AND REPORTS

38. Senator KENNEDY. General Abizaid, General Sanchez, and General Miller, it would be helpful for the committee if you would clarify and complete the various pieces of testimony on the ICRC visits and reports by having the witnesses answer the following questions. For each answer indicate the witness or witnesses who are the source of the information, whether the information is from personal knowledge or from inquiries or review of records, and that each witness has reviewed the answer and does or does not have additional or conflicting information.

What were the dates and locations of the visits the ICRC made during the period from September 11, 2001, to the present to detention or interrogation facilities or other holding facilities of any kind in Afghanistan, Guantanamo, or Iraq operated, controlled, or directed in whole or in part by the United States Government, the CPA, or any related entity?

General ABIZAIID. Historically, the ICRC determined at what level they would like to air their concerns and viewed these communications as confidential. The ICRC exercised its prerogative to address officials at the level they deemed appropriate which was generally the lowest level possible. It has been our practice in the CENTCOM AOR to address the ICRC's concern at the level of command to which they were raised, and, as I testified at the hearing, with one exception, ICRC reports were not normally surfaced all the way up through the chain of command. That exception is a report, dated May 12, 2003, concerning facilities in Iraq that was provided directly to the CENTCOM Director of Policy and Plans (J-5).

General SANCHEZ. Dates and locations of ICRC visits to facilities in Iraq are listed on the enclosed summary. A succession of commands has been engaged in continuous combat operations in Iraq since March 2003. CJTF-7 records reasonably available are provided from the date of CJTF-7's inception on June 14, 2003, to the present. CJTF-7 does not have records that may have been kept by other commands, such as CFLCC or the 800th MP BDE.

**SUMMARY OF DATES AND LOCATIONS OF ICRC VISITS TO
DETENTION FACILITIES IN IRAQ¹**

(Q. 38)

- **24-25 May 2003**, The ICRC visits the HVD detention facility, the criminal detention (CD) facility and the Corps Holding Area (CHA) at Camp Cropper.
- **10-11 June 2003**, The ICRC visits the Bayonet Detention Facility.
- **17 June 2003**, The ICRC conducts an unannounced visit to Camp Cropper.
- **19 June 2003**, The ICRC visits the Bayonet Detention Facility.
- **24 June 2003**, The ICRC visits the detainees held in Al Salihyye detention facility.
- **6-7 July 2003**, The ICRC visits detainees held in Abu Ghraib.
- **9 July 2003**, The ICRC visits the Bayonet Detention Facility.
- **9, 10, & 12 July 2003**, The ICRC delegates visit detainees held in Tasferat detention facility.
- **13, 14, and 15 July 2003**, The ICRC visits the detainees held in the HVD section in Camp Cropper.
- **7 & 12 August 2003**, The ICRC visits the Al Salihyye Detention Facility.
- **12, 13, 14 & 17 August 2003**, The ICRC visits Al-Russafa prison.
- **20-24 September 2003**, The ICRC visits Camp Bucca internment facility.
- **9-12 October 2003**, The ICRC visits Abu Ghraib Central Detention Facility.
- **14-24 October 2003**, The ICRC inspected the HVD facility at BIAP.
- **21-23 October 2003**, The ICRC visits Abu Ghraib Central Detention Facility.
- **4-8 January 2004**, The ICRC visits Abu Ghraib (Baghdad Central Correctional Facility).

¹ This summary derives only from CJTF-7 records that are currently and reasonably available. It does not include records from the 800th MP BDE or other subordinate units. It is possible that some records were not preserved in the course of continuous combat operations.

- **17-19 January 2004**, The ICRC visits the HVD Facility at Camp Cropper, BIAP.
- **7-10 February 2004**, The ICRC visits Camp Bucca, in Umm Qasr (with a physician).
- **21 February 2004**, The ICRC visits the HVD Facility at Camp Cropper, BIAP.
- **7-10 March 2004**, The ICRC visits.
- **14-18 March 2004**, The ICRC visits the Baghdad Central Detention Facility (Abu Ghraib).
- **22-25 March 2004**, The ICRC visits Camp Bucca in Umm Qasr.
- **4 April 2004**, The ICRC visits Abu Ghraib (visit of internee the ICRC had previously been denied access to pursuant to Article 143, GC IV).
- **24-27 April 2004**, The ICRC visited the HVD Facility at Camp Cropper.
- **19-23 May 2004**, The ICRC visited Camp Bucca, in Umm Qasr.
- **30 May – 6 June 2004**, The ICRC visited Abu Ghraib.

General MILLER. I defer to U.S. Southern Command (SOUTHCOM) to respond on any ICRC visits to Guantanamo.

39. Senator KENNEDY. General Abizaid, General Sanchez, and General Miller, who at any level of the CPA was aware of the visit before or at the time it took place? Who was informed of the visit after it occurred?

General ABIZAID. I am not aware of whom, if anyone, in CPA was involved with ICRC visits.

General SANCHEZ. I do not know who within CPA was aware of the October 2003 ICRC visit to Abu Ghraib before or after it took place. In early February 2003, I attended one meeting with Ambassador Bremer and representatives of the ICRC which included discussion of the working papers pertaining to the ICRC's visits in October. As a matter of practice, I understand that the CPA Office of General Counsel frequently had representatives at meetings with the ICRC at which visits were discussed and reports were provided. Meetings between CPA and ICRC representatives at which CJTF-7 personnel were not present occurred periodically throughout the period of occupation.

General MILLER. I was assigned to CJTF-7/Multi-National Force-I on April 12, 2004, and am unaware of events which occurred during the October and November time frame in regards to CPA and ICRC visits.

40. Senator KENNEDY. General Abizaid, General Sanchez, and General Miller, in what form, on what date, and, if oral, to whom was each ICRC report made? To whom was each written report delivered?

General ABIZAID. Please see my response to question #38.

General SANCHEZ. Detailed information on ICRC reports in Iraq is provided in the enclosed summary. Prior to January 2004, ICRC reports were addressed to the Commander, 800th MP BDE or one of its subordinate organizations, with a copy furnished to the CJTF-7 Staff Judge Advocate. Reports were actually delivered to a CJTF-7 Judge Advocate or to a representative of the CPA Office of General Counsel. From January until April 2004, ICRC reports were addressed to the Commander, CJTF-7 and delivered to a Judge Advocate from CJTF-7. Starting in April 2004, ICRC reports were addressed to the Deputy Commanding General, Detention Operations, and delivered to a Judge Advocate from CJTF-7. The procedure for the ICRC is to provide an oral out-brief to the camp commander at the end of each visit. The out-brief observations form the basis of the subsequent ICRC written report.

**SUMMARY OF DELIVERY OF ICRC REPORTS
(WRITTEN AND ORAL)¹**

(Q. 40, 41)

-- **27 May 2003**, The ICRC conducted an out-brief regarding their 24-25 May 2003 visit to the HVD detention facility, the criminal detention (CD) facility and the Corps Holding Area (CHA) at Camp Cropper. Attendees: ICRC Delegates Torres Jaegar and Carla Haddad, LTC Chew, Camp Cropper and 115th MP BN Commander, COL Marc Warren, V Corps SJA and members of their staffs.

-- **2 June 2003**, An ICRC CHA out-brief (second) took place at Camp Cropper. Attendees: ICRC Delegate Torres Jaegar, LTC Evans, 18th MP BDE, 115th MP BN representatives, LTC Martins, 1AD, SJA. Re-Deseminated to CJTF-7 SJA by 1ADSJA who talked with the 18th MP BDE Commander and the CFLCC PMO.

-- **16 June 2003**, The ICRC conducted a third out-brief regarding the ICRC visit to Camp Cropper. Attendees: ICRC Delegates Torres Jaegar and Walter Stocker, LTC Chew, Camp Cropper and 115th MP BN Commander, LTC Hudson, DSJA 1AD.

-- **17 July 2003**, Yayoi Hayashi of the ICRC forwarded the working paper of the 9,10 & 12 July 2003 visit of detainees held in Tasferat detention facility to LTC Burtyk 400th MP Battalion (Copy to CJTF&-OSJA).

-- **17 July 2003**, Yayoi Hayashi, (ICRC) drafted a letter to LTC Burtyk, 400th MP Battalion, Copy SJA CJTF-7 regarding the ICRC visit to Abu Ghraib on 6-7 July 2003.

-- **17 July 2003**, Nancy Fournier of the ICRC forwarded the working paper of the 24 June 2003 visit of Al Salihyye detention facility to LTC Burtyk 400th MP Battalion (Copy to CJTF-7 OSJA).

-- **26 July 2003**, Yayoi Hayashi forwarded the ICRC working papers of the 13, 14, and 15 July 2003 visit to the HVD section of Camp Cropper to LTC Chew, 115th MP and the CJTF-7 SJA.

-- **3 August 2003**, The ICRC conducted an out-brief of their visit to the Corps Holding Area at Camp Cropper. 115th MP BN representation.

¹ This summary derives only from CJTF-7 records that are currently and reasonably available. It does not include records from the 800th MP BDE or other subordinate units. It is possible that some records were not preserved in the course of continuous combat operations.

- **9 August 2003**, Phillip Spoerri, ICRC drafted the letter and working papers summarizing the main points raised after the 10-11 June, 19 June and 9 July 2003 ICRC visits to Bayonet Detention Facility. Sent to CAPT Brian Hughes, 173rd Battalion, Copy to BG Karpinsky, 800th MP BDE, Judge Campbell, Special Advisor to the Ministry of Justice, COL Warren, CJTF-7.
- **20 September 2003**, Pierre Barras of the ICRC presented the reports of the ICRC visit of 7 & 12 August 2003 to Al Salihyye Detention Facility and the 12, 13, 14 & 17 August visit to Al-Russafa prison to LTC Burtyk, Commander, 400th MP BN, BG Karpinski, Commander 800th MP BDE, and LTC James Tobin, the DSJA for CJTF-7.
- **11 October 2003**, Mr. Pierre Barras, (ICRC), wrote BG Karpinski regarding the shooting of an internee in compound 2 of Camp Bucca. DSJA CJTF-7 is copied.
- **11 October 2003**, Mr. Pierre Barras, (ICRC), wrote BG Karpinski and provides her with the working paper for the 20-24 September ICRC visit to Camp Bucca (DSJA CJTF-7 copied).
- **11 October 2003**, Mr. Pierre Barras, (ICRC), wrote BG Karpinski regarding three detainees who were injured following an Unexploded Ordnance (UXO) accident that occurred on 3 September 2003.
- **11 October 2003**, Working Papers for the ICRC visit from 20-24 September 2004 to Camp Bucca, Um Qasr presented. Describes 24 September 2003 meeting with the ICRC Delegates and MAJ Garrity (800th MP BDE), CPT Holsombeck and CPT Shaw, Field Surgeon. UK representatives included MAJ Clifton and CPT Hamnett
- **30 October 2003**, The ICRC drafted a working paper pertaining to the 14-24 October 2003 inspection of the HVD facility at BIAP.
- **6 November 2003**, Working Papers for the ICRC visit to Baghdad Central Detention Facility from 9-12 October 2003 and 21-23 October 2003.
- **12 November 2003**, The ICRC sent a letter dated 12 November 2003 enclosing the working papers relating to the visits to Camp Cropper and Abu G[hraib] in October. Addressed to BG Karpinski, Commander, 800th MP BDE.
- **8 January 2004**, The ICRC provided an oral out-brief of the 4-8 January 2004 ICRC visit to the Baghdad Central Confinement Facility (BCCF). Attendees: ICRC Delegates, Deputy Commander 205th MI BDE, CJTF-7 SJA.
- **19 January 2004**, The ICRC provided a verbal out-brief regarding their visit to the HVD Facility at Camp Cropper, BIAP. Attendees: ICRC Delegates, Commander and Staff of the 744th MP BN, CJTF-7 SJA, CJTF-7 Deputy Surgeon.

- **6 February 2004**, Ms. Eva Svoboda, ICRC sent the working papers of the 17-19 January 2004 ICRC inspection of the HVD Facility at Camp Cropper, BIAP to LTG Sanchez.
- **9 February 2004**, Eva Svoboda, (ICRC), drafted a letter to LTG Sanchez regarding the 4-8 January ICRC visits to Abu Ghraib attaching the working papers for the visits.
- **10 February 2004**, Pierre Gassman, (ICRC), drafted a letter to LTG Sanchez submitting the ICRC's Report on the Treatment by the Coalition Forces of Prisoners of War and other Protected Persons by the Geneva Conventions in Iraq during Arrest, Internment and Interrogation
- **11 February 2004**, A meeting between AMB Jones and the ICRC took place. AMB. Jones was given two ICRC Report on Detainees, one addressed to CPA and the other to CJTF-7. Report on Treatment by the Coalition Forces of Prisoners of War and other Protected Persons by the Geneva in Iraq during Arrest, Internment and Interrogation to the Coalition Provisional Authority.
- **18 February 2004**, Ms. Eva Svoboda, ICRC, requested access to the Mujahadeen Khalq Organization (MeK) residing in Camp Ashraf. Addressed to LTG Sanchez, copy to Ambassador L. Paul Bremer.
- **1 March 2004**, CJTF-7 requested and held meeting with ICRC concerning the "February report."
- **4 March 2004**, The ICRC prepared a letter for LTG Sanchez regarding the arrest and detention of three Saudi Nationals. Saad Mohammad Abdullah Al-Baddah, Salih Salim Al-Mohammadi, and Awaish Mohammad Al-Mteiri.
- **10 March 2004**, The ICRC provided a verbal out-brief regarding their inspection of the HVD Facility at Camp Cropper, BIAP. Attendees: ICRC Delegates, Commander and Staff of the 439th MP BN, ISG Representatives and Officers from the CJTF-7 OSJA.
- **11 March 2004**, The ICRC prepared a letter for LTG Sanchez with their working papers of the ICRC visit to Camp Bucca, Umm Qasr that took place from 7 to 10 February 2004.
- **18 March 2004**, Ms. Eva Svoboda (ICRC), wrote LTG Sanchez and enclosed the working paper regarding the ICRC 7-10 March 2004 visit to the HVD section of Camp Cropper.
- **25 March 2004**, Ms. Eva Svoboda (ICRC), wrote a letter to LTG Sanchez regarding the ICRC visit to Abu Ghraib from 4-8 January 2004.

-- **30 March 2004**, Ms. Eva Svoboda (ICRC), wrote a letter to LTG Sanchez describing the findings of the physician who went on the ICRC visit to camp Bucca from 7-9 February 2004 who identified and evaluated 6 detainees.

-- **31 March 2004**, Ms. Eva Svoboda wrote LTG Sanchez a letter enclosing the working papers for the 14-18 March ICRC visit to Abu Ghraib and the 22-25 March 2004 visit to Camp Bucca in Umm Qasr.

-- **31 March 2004**, Ms. Eva Svoboda wrote LTG Sanchez regarding the ICRC 4-8 January 2004 visit to Abu Ghraib.

-- **24 April 2004**, Dr. Pancho Duda, (ICRC) wrote a letter to COL James Bruckart, MD, the CJTF-7 Surgeon regarding his assessment of the health care system.

-- **27 April 2004**, The ICRC gave an out-brief regarding their 24-27 April 2004 visit to the HVD Facility at Camp Cropper. Attendees: ICRC Delegates, Camp Commander, LTC Vernon "Wayne" Sylvester, the Camp Physician, COL (Dr.) Roger Lalich, and the CJTF-7 SJA.

-- **9 May 2004**, Ms. Eva Svoboda (ICRC) wrote a letter to LTG Sanchez and provides a copy of the working papers of the 2[4]-27 ICRC visit to the HVD section of Camp Cropper.

-- **25 May 2004**, An ICRC medical doctor identified and evaluated 7 internees at Camp Bucca and wrote a letter.

-- **26 May 2004**, Ms. Eva Svoboda (ICRC) wrote a letter to LTG Sanchez regarding the 19-23 May 2004 ICRC visit to Camp Bucca with enclosed working papers.

General MILLER. Prior to April 12, 2004, I do not know who received reports from the ICRC. Since April 12, 2004, I have served as the single point of contact for all matters related to the ICRC and detainee operations.

41. Senator KENNEDY. General Abizaid, General Sanchez, and General Miller, to whom was each report disseminated by the person who first received it and by each successive recipient and when? If the witnesses do not know and cannot determine all the recipients, explain why.

General ABIZAID. The May 12, 2003, ICRC report delivered to the CENTCOM J-5 was provided by him to the CENTCOM Chief of Staff. It was not brought to my attention and I do not know if it was disseminated further.

General SANCHEZ. Information on ICRC reports in Iraq is provided in the previously enclosed summary. Originals of reports were provided to the addressee. Copies of reports or extracts of the reports were typically disseminated within the command to C-2 (Intelligence), C-3 (Operations), Provost Marshal, Engineer, Surgeon, and Staff Judge Advocate. All of the recipients of each report cannot be determined with specificity. The command was conducting continuous combat operations during this period.

General MILLER. Prior to April 12, 2004, I do not know who received reports from the ICRC. Since April 12, 2004, I have served as the single point of contact for all matters related to the ICRC and detainee operations.

42. Senator KENNEDY. General Abizaid, General Sanchez, and General Miller, who wrote or otherwise gave any summaries, memoranda, reports, or other descriptions of each report, when and to whom were they disseminated and re-disseminated?

General ABIZAID. In Afghanistan, the CJTF Staff Judge Advocates have, in the past, designated a point of contact (POC) who routinely met with the ICRC and received reports together with other representatives from the detention center and the command. In Iraq, MG Miller has instituted detailed procedures for handling ICRC

correspondence. MG Miller met with the ICRC and established himself as the single POC for all ICRC matters to include documents, working papers, visit coordination, and any other ICRC-related issues which may arise.

General SANCHEZ. Information on summaries, memoranda, and reports is provided in the enclosed summary. All of the recipients of each report cannot be determined with specificity. The command was conducting continuous combat operations during this period.

SUMMARIES AND ANALYSES OF ICRC REPORTS¹

(Q. 42)

- **27 May 2003**, COL Marc L. Warren prepared an EXSUM regarding the ICRC 24-25 May 2003 visit to the HVD detention facility, the criminal detention (CD) facility and the Corps Holding Area (CHA) at Camp Cropper.
- **27 May 2003**, MAJ Jonathan A. Kent prepared a MEMORANDUM FOR Record regarding the ICRC 24-25 May 2003 visit to the HVD detention Facility, the Criminal detention (CD) facility and the Corps Holding Area (CHA) at Camp Cropper.
- **27 May 2003**, CPT R. Scott Harbison (MP) prepared a Memorandum For the Provost Marshal regarding his notes on the 24-26 May 2003 ICRC visit to the Baghdad Special Confinement Facility.
- **18 June 2003**, CPT James Wherry, Camp Cropper CJA drafted a Memorandum for the CDR, 115th MP BN SUBJECT: Third ICRC Out Brief, CHA and HVA Facilities, Camp Cropper on 16 June 2003. (Unannounced visit report).
- **14 September 2003**, LTC James Tobin drafted a memorandum for COL Marc Warren summarizing the 13 September 2003 meeting with the ICRC at CPA.
- **20 September 2003**, A Memorandum from LTC James Tobin to COL Marc Warren summarizing the weekly meeting with the ICRC at CPA was prepared.
- **25 November 2003**, MAJ George O'Kane (SJA Ops) prepared a Review of ICRC Detention Visits for the [18]-24 October ICRC inspection of the HVD Facility at BIAP.
- **27 November 2003**, S.G. Lythgoe, the DSJA for CJTF-7 sent a memorandum to the Cdr, 800th MP Brigade regarding the ICRC visits to Baghdad Central Detention Facility.
- **8 January 2004**, COL Marc Warren prepared a memorandum for the COS, DCG and CG regarding the ICRC Visit to Abu Ghraib which occurred 4-8 January 2004.
- **8 January 2004**, MAJ Laura Potter, the Deputy Cdr of the 205th MI Bde drafted a Memorandum For Record following the 4-8 January 2004 ICRC visit to Abu Ghraib.

¹ This summary derives only from CJTF-7 records that are currently and reasonably available. It does not include records from the 800th MP BDE or other subordinate units. It is possible that some records were not preserved in the course of continuous combat operations.

-- **22 January 2004**, COL Marc Warren wrote a letter to COS, DCG and CG regarding the ICRC out-brief of their 17-19 January 2004 inspection of the HVD Facility at Camp Cropper, BIAP.

-- **7 February 2004**, MAJ George O'Kane drafted a memorandum to the Chief of Detention Operations Regarding ICRC Inspection Preparation and Execution.

-- **13 March 2004**, Squadron Leader Taylor prepared a memorandum for COL Marc Warren regarding the ICRC visit of the HVD Facility at Camp Cropper that took place 7-10 March 2004.

-- **27 April 2004**, COL Marc Warren wrote the DCG (Detention Ops) regarding the ICRC visit of Saddam Hussein at Camp Cropper.

General MILLER. Prior to April 12, 2004, I do not know who received reports from the ICRC. Since April 12, 2004, I have served as the single point of contact for all matters related to the ICRC and detainee operations.

43. Senator KENNEDY. General Abizaid, General Sanchez, and General Miller, please provide copies of each report or document describing the report not already provided and identify any report which has already been provided to the committee. Please provide all summaries, memoranda, reports, or other descriptions of each report.

General ABIZAID. It is my understanding that copies of all documents responsive to your request have or will be provided by the Office of the Assistant Secretary of Defense for Legislative Affairs.

General SANCHEZ. All known and available reports have been provided.

General MILLER. All known and available reports have been provided.

44. Senator KENNEDY. General Abizaid, General Sanchez, and General Miller, were there outstanding orders, Field Manual provisions, or other SOPs at any level anywhere for the handling of requests for visits and visits from the ICRC? If so, what were they? Please provide copies of all versions since September 11, 2001, including any written, oral communications, orders, or other statements altering or providing exceptions to the stated procedures.

General ABIZAID. Appendix 1 to Annex E to the CENTCOM Operational Plan 1003V, EPW, Retained Persons, Civilian Internees, and other Detainees, dated September 25, 2002, paragraph 5(f), briefly addresses ICRC visits. In addition, an internal memo outlining procedures for ICRC visits was developed by CJTF-7 in February 2004. The following official documents may be consulted generally on the subject of ICRC visitations: DODD 2310.1; Joint Publication 1-0, Appendix T; and Army Regulation 190-8.

General SANCHEZ. An internal memo outlining procedures for ICRC visits was developed by Judge Advocates within the command. This memo, dated February 7, 2004, is enclosed. In addition, our Judge Advocates rely upon guidance contained in the Operational Law Handbook, which discusses visits by the ICRC and, in particular, the role Judge Advocates play in the process. I am enclosing the appropriate section from the handbook, as well as a portion of a cited field manual (FM 71-100-2) dealing with the same topic.

FOR OFFICIAL USE ONLY
HEADQUARTERS
 COMBINED JOINT TASK FORCE SEVEN
 BAGHDAD, IRAQ
 APO AE 09303

REPLY TO
 ATTENTION OF

CJTF7-OSJA

7 February 2004

MEMORANDUM FOR Chief, Detention Operations (OSJA)

SUBJECT: International Committee for the Red Cross (ICRC) Inspection Preparation and Execution

1. **Background.** The ICRC will conduct inspections of detention facilities in Theatre in accordance with the Geneva Conventions of 1949. The frequency of these inspections could be expected to be once every 1-2 months. The following procedures worked well during the last round of inspections in Jan 04 to ensure a successful inspection both from the military and ICRC perspective. The key element to a successful visit is timely communication with interested parties in order that proper inspection preparation is undertaken and coordinated.
2. **ICRC Visit Dates.** While the ICRC are entitled to conduct inspections unannounced, past experience (namely the Oct 03 inspections) has converted them to giving prior notice of intended inspections. Currently, CJTF-7 can expect to get 3 to 4 weeks notice of a proposed visit to a detention facility. This is normally communicated to the Office of General Counsel (LTC Paul Muggleton) at CPA.
3. **Pre-Inspection Contact.** Timing is everything. Approximately two weeks before the inspection, it is best to contact the MPs responsible for the facility and the interrogation organization (MI or OGA) to warn them out about the inspection (if not already done) and to arrange to have a coordination meeting the following week (that is the week before the visit – ideally two to three days before the visit).
4. **Pre-Inspection Meeting.** This should be held two to three days before the ICRC inspection at the facility to be inspected. This generally gives enough time to prepare for the arrival of the ICRC as a current issue. It needs to be attended by MPs and representatives from the interrogation organization. The meeting agenda should include:
 - a. Dates and timings of the inspection;
 - b. Date, timing and location of the ICRC Outbrief;
 - c. Sequence, attendance and venue of the arrival briefing to ICRC;
 - d. Contents of arrival briefing to ICRC;
 - e. Arrangement of life support for ICRC team – accommodation, toilets, showers and meals during inspection;
 - f. Escorts for the inspection team – number of escorts and how it is proposed to divide up the delegates, if at all, during their inspection.

FOR OFFICIAL USE ONLY

- g. Details of any internees/detainees that the ICRC will not have access to due to active interrogation, relying on the derogations in Geneva III/126 or Geneva IV/143

By the conclusion of the meeting, all parties at the facility should have a clear understanding of their responsibilities for the inspection, and how it is to proceed.

5. **Arrival Briefing.** The purpose of this briefing is to welcome the ICRC, orientate them to the facility, advise them of their life support aspects of the inspection, security issues and to lay out the ground rules for the visit. This has to be against a background of their right to a free and unrestricted visit, although the derogations in the Geneva Convention do allow impositions to be placed on the inspection for reasons of 'imperative military security'. In summary, the ICRC have accepted that they will be escorted (to a degree) during their inspections by an escort officer for reasons of administrative support and security, who is also to ensure that their movements in the facility are as arranged. The escort should not hear or observe individual interviews with the internees. The arrival briefing will also set out a time and place for the twice-daily coordination meetings. Following the arrival briefing, it is helpful for the inspection team to be given a walk around inspection of the facility if the delegates have not been part of a prior inspection.

6. **Daily Coord Meetings.** These are control measures. There should be a morning meeting, which generally takes no more than five minutes, where the inspection team meets their escort for the day, and their inspection program for that day is confirmed. The evening meeting also only takes five to 10 minutes, and is to confirm that the days inspection was without incident, answer any questions that cannot wait until the Outbrief, coordinate any admin points, and to confirm the inspection program for the following day. It should be noted that one of the purposes for the evening coordination meeting was to give the ICRC the opportunity to address any questions that the delegates had during that day, and hence avoid questions to their escorts. The ICRC will normally commence their daily inspection at around 0845hr to 0900hr and will conclude for the day at approximately 1700hr to 1800hr.

7. **Outbrief.** This is where the ICRC will summarize their points for the visit. It will normally be held on the morning of departure. It is our opportunity to put our case forward for any criticisms they may have. It is therefore important that senior representatives from MPs, the intelligence entity and SJA attend, as the result of this brief and the visit will be formulated into a report to be later staffed to the CG. The Outbrief will normally be of a 60 to 90 minute duration.

GEORGE X. O'KANE
Major (Aust)
OSJA, CJTF-7 (Main)

For a nation that is a member of the UN, these provisions of the Charter, if implemented, may qualify that member nation's right to remain neutral in a particular conflict. For example, if a member nation is called on by the Security Council, pursuant to Articles 42 and 43 of the Charter, to join in collective military action against an aggressor state, that member nation loses its *right* to remain neutral. However, the member nation would actually lose its neutral status only if it complied with the Security Council mandate and took hostile action against the aggressor.

COMPLIANCE WITH THE LAW OF WAR

The Role of Protecting Powers and the ICRC

The System of Protecting Powers. Common Articles 8 - 11 of the Geneva Conventions of 1949⁴ provide for application of the Conventions in time of international armed conflict "with the cooperation and under the scrutiny of the Protecting Powers whose duty it is to safeguard the interests of the Parties to the conflict." The diplomatic institution of protecting powers, which developed over the centuries independent of the Law of War, enables a neutral sovereign state, through its designated diplomatic representatives, to safeguard the interests of a second state in the territory of a third state. Such activities in wartime were first given formal recognition in the Geneva Prisoner of War Convention of 1929.

Such protecting power activities are especially valued when the second and third state do not have effective diplomatic relations, which is traditionally the case in time of war between them. In particular, the protecting power attends to the humanitarian interests of those citizens of the second state who are within the territory and under the control of the third state, such as prisoners of war and civilian detainees.

Protecting power activities reached their zenith during World War II, as the limited number of neutral states acting as protecting powers assumed a role as representatives not merely of particular belligerents, but rather as representatives of the humanitarian interests of the world community. Article 5 of GP I seeks to supplement (not supplant) the protecting power system embodied in the Geneva Conventions by imposing on the parties to the conflict the duty to implement that system from the beginning of the conflict.

The Contributions and Role of the International Committee of the Red Cross (ICRC). Originally formed in 1863, the ICRC is an organization of Swiss citizens that has played a seminal role in the development of humanitarian law applicable in armed conflict. In addition, during World War II, the ICRC supplemented the efforts of the protecting powers, and undertook prodigious efforts on behalf of prisoners of war. Those efforts included the establishment of a Central Prisoner of War Agency with 40 million index cards, the conduct of 11,000 visits to POW camps, and the distribution of 450,000 tons of relief items.

The role of the ICRC as an impartial humanitarian organization is formally recognized in both common articles 9 - 11 of the Geneva Conventions⁵ and in the Protocols. Since World War II, the protecting power system has not been widely used, and the ICRC has stepped into the breach as a substitute for protecting powers in international conflicts, under the auspices of common articles 9 and 10 of the Geneva Conventions⁶ and Articles 5 and 6 of Protocol I.

With respect to non-international conflicts, common article 3 of the Geneva Conventions recognizes the prerogative of the ICRC or other impartial humanitarian organizations to offer its services to the parties to the conflict.

GP II, however, fails to reaffirm this ICRC prerogative and recognizes, in Article 18, only the offer of services by "relief societies located in the territory" of a party to the conflict.

Relations between U.S. Forces and the ICRC

Subject to essential security needs and other reasonable requirements, the ICRC must be permitted to visit PWs and provide them certain types of relief. Typically, the U.S. will invite the ICRC to observe PW conditions as soon as

⁴ Articles 9 - 12 of the GC.

⁵ Articles 10 - 12 of the GC.

⁶ Articles 10 and 11 of the GC.

circumstances permit. Once on the scene, the ICRC will closely examine compliance with the Law of War and, in particular, the Geneva Conventions concerning a broad range of issues.

Given his professional qualifications and specialized training in the Law of War, the judge advocate should serve as the escort and liaison officer with the ICRC.⁷ This role is doctrinal, and stated in FM 71-100-2, *INFANTRY DIVISION OPERATIONS TACTICS, TECHNIQUES, AND PROCEDURES*, page 6-28. The judge advocate can quickly identify and resolve many Law of War issues before they become a problem for the commander. For those Law of War matters requiring command decision, the judge advocate is best suited to provide advice to the commander and obtain timely responses. These same skills are essential in dealing with ICRC observers. The judge advocate can best serve as the commander's skilled advocate in discussions with the ICRC concerning the Law of War.

Both the commander and the judge advocate should recognize that the ICRC, as an impartial humanitarian organization, is not a political adversary, eagerly watching for and reporting Law of War violations.⁸ Rather, it is capable of providing assistance in a variety of ways. In recent conflicts, the ICRC assisted in making arrangements for the transportation of the remains of dead enemy combatants and for repatriating PWs and civilian detainees. By maintaining a close working relationship with ICRC representatives, the judge advocate receives a two-fold benefit. He is assisted in identifying Law of War issues before they pose problems to the command, and he has access to additional legal resources that may be used to resolve other Law of War matters.

The ICRC is also heavily involved in MOOTW, where it may be present in conjunction with numerous other organizations and agencies. In the former Yugoslavia, Somalia, and Rwanda, for example, many international organizations are or were engaged in "humanitarian relief" activities. Among the most significant is the UN High Commissioner for Refugees (UNHCR). The list of private voluntary organizations (PVOs) and nongovernment organizations (NGOs) in the field is large; approximately 350 humanitarian relief agencies are registered with the U.S. Agency for International Development (USAID).

REMEDIES FOR VIOLATIONS OF THE LAW OF WAR

U.S. Military and Civilian Criminal Jurisdiction

It is DoD policy that a member of the armed forces who commits an offense that qualifies as a "war crime" will be charged under a specific article of the UCMJ. In the case of other persons subject to trial by general courts-martial for violating the laws of war (UCMJ, art. 18), the charge shall be "Violation of the Laws of War" rather than a specific UCMJ article.

The War Crimes Act of 1997 (18 U.S.C. § 2401) provides federal courts with jurisdiction to prosecute any person inside or outside the U.S. for war crimes where a U.S. national or member of the armed forces is involved as an accused or as a victim.

"War Crimes" are defined in the War Crimes Act as (1) grave breaches as defined in the Geneva Conventions of 1949 and any Protocol thereto to which the U.S. is a party; (2) violations of Articles 23, 25, 27, 28 of the Annex to the Hague Convention IV; (3) violations of Common Article 3 of the Geneva Conventions of 1949 and any Protocol thereto to which the U.S. is a party and deals with a non-international armed conflict; (4) violations of provisions of Protocol on Prohibitions or Restrictions on the Use of Mines, Booby-Traps & Other devices (Protocol II as amended May, 1996) when the U.S. is a party to such Protocol and the violation willfully kills or causes serious injury to civilians.

U.S. policy on application of the Law of War is stated in DoD Directive 5100.77 (DoD Law of War Program) and further explained in CJCSI 5810.01 (12 Aug 96) (Implementation of the DoD Law of War Program). Except when

⁷ General Prugh (former TJAG) fulfilled the task of "interfacing" with the ICRC when he was the legal advisor to CDR, MACV in Vietnam. General Prugh relates that during the early stages of Viet Nam, OTJAG concluded that the U.S. was involved in an Art 3, not Art 2, conflict. In June 65 the situation had changed, and by Aug 65 a formal announcement was made that Art 2 now applied. Soon, ICRC delegates began to arrive, and it fell upon the judge advocates to meet with the delegates. This role continued in operations in Grenada, Panama, Somalia, Haiti, and during the Gulf War. The development of this liaison role was also apparent in Haiti, particularly in the operation of Joint Detention Facility.

⁸ It is essential to understand the neutrality principle of the ICRC. One must stay at arm's length from the delegates so not to risk harming their relationships with the enemy. For example, ICRC personnel will meet with prisoners in private.

31 Aug 1993

FM 71-100-2, Chapter 6
Operations Other Than War - Noncombatant Evacuation Procedures

- Determines the need for veterinary personnel, based on source of subsistence.
- Identifies and prepares for any special medical problems among evacuees.
- Coordinates with HN medical facilities for assistance.
- Identifies from Department of Staff sources unauthorized drugs that evacuees may have.
- Ensures adequate HSS is available to support the force and evacuees.
- Identifies the need for preventive medicine personnel based on diseases among NEO population.

The *SJA* provides advice on international law issues, including--

- Political asylum.
- Foreign claims.
- Contract and fiscal law matters.

He serves as an escort and liaison, where appropriate, for members of the International Committee of the Red Cross in country. The *SJA* also maintains close and continuous coordination with the G5, G2, and provost marshal to ensure legal review and coordination of PSYOPS, intelligence collection, and security and maintenance of law and order among US forces and evacuees.

The *PMO* tailors MP forces to support the evacuation ground force; conducts circulation control operations; assists in processing, safeguarding, and evacuating NEO personnel; and plans traffic and crowd control procedures.

The *ADSO* determines the most effective communications with US embassy personnel, including HF frequencies and FM. He also--

- Prepares signal portion of staff estimate.
- Analyzes CEOI for joint and combined interoperability requirements.
- Develops coded execution checklists.
- Ensures that communications redundancy is achieved for each net.
- Obtains telephone listings for all persons and activities that may be needed during the operation (wardens, embassy, police, military).

The *PAO* determines the need for public affairs support in the AO and at the reception center, responds to all media queries based on the sensitivity of the mission and OPSEC considerations, and organizes a media pool with escort officer, if required.

The *division chaplain* determines the need for religious support for evacuees and coordinates for required religious services and pastoral care.

PEACEKEEPING OPERATIONS

Military peacekeeping operations support diplomatic efforts to achieve or maintain peace in areas of potential conflict. The UN has been the most frequent sponsor of peacekeeping operations. Historically, US Army battalion or brigade task forces have been involved in

1. The role of the ICRC as an impartial humanitarian organization is formally recognized in common articles 9 - 11 and Articles 125, GPW, and 63, GC, of the Geneva Conventions¹⁴. Since World War II, the Protecting Power system has not been widely used, and the ICRC has stepped into the breach as a substitute for government Protecting Powers in international armed conflicts, subject to the consent of the Parties to the conflict.

2. With respect to non-international conflicts, common article 3 of the Geneva Conventions recognizes the prerogative of the ICRC or other impartial humanitarian organizations to offer its services to the parties to the conflict.

3. Relations between U.S. Military and the ICRC

a. Subject to essential security needs, mission requirements and other legitimate, practical limitations, the ICRC must be permitted to visit PWs and provide them certain types of relief. Typically, the U.S. will invite the ICRC to observe PW, civilian internee or detainee conditions as soon as circumstances permit. The invitation to the ICRC for its assistance is made by the United States Government (Department of State, in coordination with the Department of Defense), and not by the Commanding Commander.

b. Given his professional qualifications and specialized training in the Law of War, the judge advocate should serve as the escort and liaison officer with the ICRC.¹⁵ This role is essential, and stated in FM 71-100-2, *INFANTRY DIVISION OPERATIONS TACTICS, TECHNIQUES, AND PROCEDURES*, page 6-28. The judge advocate can quickly identify and resolve many Law of War issues before they become a problem for the commander. For those Law of War matters requiring command decision, the judge advocate is best suited to provide advice to the commander and obtain timely responses. These same skills are essential in dealing with ICRC observers. The judge advocate can best serve as the commander's skilled advocate in discussions with the ICRC concerning the Law of War.

c. Both the commander and the judge advocate should recognize that the ICRC, as an impartial humanitarian organization, is not a political adversary, eagerly watching for and reporting Law of War violations.¹⁶ Rather, it is capable of providing assistance in a variety of ways. In recent conflicts, the ICRC assisted in making arrangements for the transportation of the remains of dead enemy combatants and for repatriating PWs and civilian detainees. By maintaining a close working relationship with ICRC representatives, the judge advocate receives a two-fold benefit. He is assisted in identifying Law of War issues before they pose problems to the command, and he has access to additional legal resources that may be used to resolve other Law of War matters.

4. The ICRC is also heavily involved in MDOOTW, where it may be present in conjunction with numerous other organizations and agencies. In the former Yugoslavia, Somalia, and Rwanda, for example, many international organizations are or were engaged in "humanitarian relief" activities. Among the most significant is the UN High Commissioner for Refugees (UNHCR). The list of private voluntary organizations (PVOs) and Nongovernmental organizations (NGOs) in the field is large; approximately 550 humanitarian relief agencies are registered with the U.S. Agency for International Development (USAID).

XX. REMEDIES FOR VIOLATIONS OF THE LAW OF WAR

A. U.S. Military and Civilian Criminal Jurisdiction

1. It has been the historic practice of the military services that a member of the U.S. military who commits an offense that may be regarded as a "war crime" will be charged under a specific article of the UCMJ.

¹⁴ Articles 10 - 12 of the GC.

¹⁵ General Probst (Major TJAG) fulfilled the task of "liaison" with the ICRC when he was the legal advisor to CDR, MACV in Vietnam. General Probst states that during the early stages of Viet Nam, CJTAG concluded that the U.S. was involved in an Art 3, not Art 2, conflict. In June 65 the situation had changed, and by Aug 65 a formal announcement was made that Art 2 now applied. Soon, ICRC delegates began to arrive, and it fell upon the judge advocate to assist with the delegates. This role continued in operations in Grenada, Panama, Somalia, Haiti, and during the Gulf War. The development of the liaison role was also apparent in Haiti, particularly in the operation of Joint Detention Facility.

¹⁶ It is essential to understand the neutrality principle of the ICRC. One must stay at arm's length from the delegates so as not to risk losing their relationship with the enemy. For example, ICRC personnel will meet with prisoners in prison.

FM 71-100-2

senior medical officer, and coordinates with the G2 for medical information on the evacuees. He also—

- Determines the need for veterinary personnel, based on source of substances.

- Identifies and prepares for any special medical problems among evacuees.

- Coordinates with HN medical facilities for assistance.

- Identifies from Department of Staff sources unauthorized drugs that evacuees may have.

- Ensures adequate HSS is available to support the force and evacuees.

- Identifies the need for preventive medicine personnel based on diseases among NEO population.

The SJA provides advice on international law issues, including—

- Political asylum.

- Foreign claims.

- Contract and local law matters.

He serves as an expert and liaison, where appropriate, for members of the International Committee of the Red Cross in country. The SJA also maintains close and continuous coordination with the G5, G2, and provost marshal to ensure legal review and coordination of PSYOPS, intelligence collection, and security and maintenance of law and order among US forces and evacuees.

The FMO tailors MP forces to support the evacuation ground force; conducts circulation control operations; assists in processing, safeguarding, and evacuating NEO personnel; and plans traffic and crowd control procedures.

The ADESO determines the most effective communications with US embassy personnel, including HF frequencies and FM. He also—

- Prepares signal portion of staff estimate.

- Analyzes CEU for joint and combined interoperability requirements.

- Develops coded message checklists.

- Ensures that communications redundancy is achieved for each net.

- Obtains telephone listings for all persons and activities that may be needed during the operation (wards, embassy, police, military).

The PAO determines the need for public affairs support in the AO and at the reception center, responds to all media queries based on the sensitivity of the mission and OPSEC considerations, and organizes a media pool with escort officer, if required.

The division chaplain determines the need for religious support for evacuees and coordinates for required religious services and pastoral care.

PEACEKEEPING OPERATIONS

Military peacekeeping operations support diplomatic efforts to achieve or maintain peace in areas of potential conflict. The UN has been the most frequent sponsor of peacekeeping operations. Historically, US Army battalions or brigade task forces have been involved in peacekeeping operations. However, divisions must be aware of the uniqueness of these types of operations. To be effective, the following conditions must be established for the peacekeeping force:

- Consent, cooperation, and support of the disputing parties.

- Political recognition of the peacekeeping force by a portion of the international community.

- Clear rules of engagement.

- Sufficient freedom of movement for the force to conduct its mission.

- An effective C₂ system.

- An effective intelligence capability.

Peacekeeping often involves ambiguous situations requiring the peacekeeping force to deal with extreme tension and violence without becoming a participant. These operations follow diplomatic negotiations which establish the mandate for the peacekeeping force. The mandate describes the scope of the peacekeeping operation in detail. It typically determines the size and type of force each participating nation contributes. To ensure an effective peacekeeping operation, a mandate should have—

- Conditions the host nation intends to impose on the peacekeeping force.

6-23

General MILLER. Prior to April 12, 2004, I do not know who issued specific guidelines, field manuals or SOPs for dealing with the ICRC. Since April 12, 2004, I have served as the single point of contact for all matters related to the ICRC and detainee operations and as such I receive all reports from the ICRC directly.

45. Senator KENNEDY. General Abizaid, General Sanchez, and General Miller, were there outstanding orders, field manual provisions, or other SOPs at any level anywhere for the dissemination and handling of, or responses to, such oral or written reports? If so, what were they? Please provide copies of all versions since Sep-

tember 11, 2001, including any written, oral communications, orders, or other statements altering or providing exceptions to the stated procedures.

General ABIZAD. The tri-service regulation on EPWs and civilian internees, Army Regulation 190-8, paragraph 3-16, briefly addresses handling of ICRC reports and requires that they be forwarded by the relevant camp commander through Army channels to Headquarters, Department of the Army. As I stated in my testimony, I believe the reporting process for ICRC reports was broken and subsequent to that hearing I directed my staff to conduct a review of these procedures. Consequently, CENTCOM has recently implemented a new policy which requires subordinate units to provide copies of all ICRC correspondence within 48 hours of receipt to the Office of The Staff Judge Advocate, CENTCOM. Additionally, subordinate units are to immediately provide CENTCOM with responses to all ICRC concerns. ICRC correspondence is immediately analyzed in light of the unit responses, and submitted to my Chief of Staff (through the Joint Security Director) for review and any necessary action by me.

General SANCHEZ. I am not aware of any outstanding orders, field manual provisions, or other SOPs that prescribe how to handle ICRC reports. In January 2004, I orally directed that ICRC reports would be addressed to me and provided to my Staff Judge Advocate section. In April 2004, I directed that ICRC reports would be received by the Deputy Commanding General, Detention Operations.

General MILLER. Prior to April 12, 2004, I do not know who issued specific guidelines, field manuals or SOPs for dealing with the ICRC. Since April 12, 2004, I have served as the single point of contact for all matters related to the ICRC and detainee operations and as such I receive all reports from the ICRC directly.

DOD INQUIRY OF ABU GHRAIB

46. Senator KENNEDY. General Abizaid, General Sanchez, and General Miller, have you been the subject of, participated in, or become aware of any internal DOD inquiry into or investigation of the matters raised by these questions or the issues raised at the May 19 hearing? If so, please provide the name of the person and office conducting that inquiry or investigation, the date it began, and copies of any materials or information you provided for that purpose. If you were interviewed, please provide the date of the interview, the name of the interviewer, and a copy of any notes, summary, transcript, or other record of the interview. If there has been a report, summary, or other document or oral presentation arising out of such inquiry or investigation, please provide a copy or if oral your knowledge of the contents of the oral presentation.

General ABIZAD. I am aware of the following investigations/inquiries:

- a. Schlesinger Panel.
- b. Interrogations Special Focus Team (Admiral Church)
- c. Sec Navy Detainee Review
- d. Jacoby Assessment (CFC-A)
- e. Taguba AR 15-6
- f. MG Fay Procedure 15
- g. Miller Report
- h. Ryder Report
- i. Formica AR 15-6
- j. Army Inspector General (IG) Report
- k. Army Reserve Review of Training

To the best of my knowledge, the Taguba, Miller, and Ryder reports are complete and available. In addition, I have provided an interview for the Schlesinger Panel and the Interrogation Special Focus Team (Admiral Church).

General SANCHEZ. I am aware of the investigation initiated on January 19, 2004, at my request by MG Antonio Taguba and conducted under the provisions of Army Regulation 15-6. This investigation is complete and I understand that a copy of the report of investigation has been provided to Congress.

I am also aware of the ongoing investigation initially appointed by me under the provisions of Army Regulation 15-6 in which MG George Fay is the investigating officer. At my request, a superior appointing authority was named by the acting Secretary of the Army. I have not been interviewed by MG Fay.

I am also aware of the appointment of a DOD Independent Commission on Detention Practices, appointed by the Secretary of Defense in May 2004. I was interviewed by this body on June 24, 2004. Because its report has not yet been completed, I refer you to the Commission for any records of my interview.

I am aware of the investigation being conducted by Vice Admiral Church, also at the direction of the Secretary of Defense. I have not been interviewed by Vice Admiral Church.

Additionally I am aware of an ongoing USACIDC investigation. I have not been interviewed in this investigation.

General MILLER. Yes. I have been interviewed by the OSD Schlezinger Independent Panel to Review DOD Detention Operations and MG Fay's investigation. As all investigations/panels remain ongoing, I cannot comment on them at this time.

NON-DISCLOSURE AGREEMENTS

47. Senator KENNEDY. General Abizaid, General Sanchez, and General Miller, there are reports that persons with information potentially relevant to our inquiry have been asked to sign non-disclosure or other agreements precluding their disclosing what they know and that others may have been threatened with courts martial or other reprisals if they disclose what they know. Please tell us everything you know about these allegations.

General ABIZAID. I am not aware of persons being asked to sign nondisclosure statements or threatened with courts-martial or reprisals for providing information to investigators.

General SANCHEZ. I am not aware of any such agreement within my command, nor do I know anything about the allegations.

General MILLER. I have no knowledge of any actions of this nature.

JUDGE ADVOCATE GENERAL OFFICERS

48. Senator KENNEDY. General Abizaid, General Sanchez, and General Miller, there have been published allegations that JAG officers have been excluded from the legal decisionmaking and implementation of policies in the field of interrogation and detention practices, and have been displaced by civilian attorneys and officials at DOD. Please tell us everything you know about the substance of these allegations.

General ABIZAID. I am not aware of JAG officers being excluded from the legal decisionmaking and implementation of policies in the field of interrogation and detention practices at CENTCOM. I actively seek and routinely rely on the advice and counsel of my Staff Judge Advocate on all such matters.

General SANCHEZ. This is not the case at the task force level. Judge Advocates are integral members of my command, full participants in operations, and relied upon to provide legal advice and support in the field of interrogation and detention practices in the field. I have no knowledge of the role of JAG officers at higher levels.

General MILLER. I have no knowledge of any actions of this nature.

ICRC REPORTS

49. Senator KENNEDY. Colonel Warren, apparently you received one or more ICRC reports yourself (as will be indicated in full in the answers to the previous questions). Who determined, and on what basis, that you should receive those reports?

Colonel WARREN. CJTF-7 Judge Advocates typically received copies of the reports from the ICRC at our periodic meetings. If a representative of the 800th MP BDE was not present at the meeting, we would also receive the original report and provide it to the Brigade or the CJTF-7 Provost Marshal's office. This protocol was self-imposed and was not determined by superior authority. In January 2004, we informed the ICRC to address reports to LTG Sanchez and provide the original reports to me or to a CJTF-7 Judge Advocate. Previously, CJTF-7 was given copies of reports (often with my name on the "copy furnished" line) that were addressed to commanders within the 800th MP Brigade. It is certainly possible that one or more reports would have been given to me at a meeting, either as copies or sealed originals for another addressee. However, I recall receiving only other correspondence that was addressed by name to LTG Sanchez. After the bombing of the ICRC headquarters in the fall of 2003, most meetings with the ICRC were held at the CPA. There, ICRC meetings were also attended by one or more attorneys from the CPA Office of General Counsel, as well as MP officers (and MI officers as available as well). If a CJTF-7 Staff Judge Advocate officer was not present at a meeting, a CPA General Counsel attorney would receive the report.

50. Senator KENNEDY. Colonel Warren, what did you think your responsibilities and obligations required you to do with those reports? Which of the following did you think you were receiving them on behalf of: the facility Commander, JTF-7, CENTCOM, JAG, MI, DOD, or OSD? Which of those, and who else, did you disseminate the reports or descriptions of the reports to? Who told you whom to disseminate them to? Why did you not disseminate them to each of those people or entities?

Colonel WARREN. The reports were directed to the addressees. Starting in January 2004, I began accepting original reports on behalf of CJTF-7. For this reason, I had my officers ensure that the reports had been or were provided to activities that had responsibilities for the facilities: C-2, C-3 (PMO), 800th MP BDE, 205th MI BDE, and the camp commander. As a result of the October 2003 ICRC visit to Abu Ghraib and the delay in responding to the November 2003 ICRC report, I recommended to the Commander, CJTF-7 that, as a matter of procedure, all future ICRC reports be addressed to the Commander, CJTF-7 and given to a CJTF-7 Judge Advocate. Starting with the January 2004 ICRC visit to Abu Ghraib, this was the practice followed until changed by the Deputy Commanding General, Detention Operations in April 2004.

51. Senator KENNEDY. Colonel Warren, what was your personal reaction when you saw or heard those reports?

Colonel WARREN. For purposes of questions 51 through 55, I assume you are referring to the reports pertaining to the October 2003 ICRC visit. My reaction was one of surprise and disbelief. The report seemed so implausible as to be unbelievable.

52. Senator KENNEDY. Colonel Warren, did you think the activities described were consistent with applicable policy?

Colonel WARREN. Not if the report was accurate.

53. Senator KENNEDY. Colonel Warren, did you think the activities described were consistent with the Geneva Conventions?

Colonel WARREN. Not if the report was accurate.

54. Senator KENNEDY. Colonel Warren, did any of the activities described surprise or outrage you?

Colonel WARREN. Yes. Please see my response to question 51.

55. Senator KENNEDY. Colonel Warren, did you think that the reports required remedial action?

Colonel WARREN. Yes. Remedial action was taken as described in my responses to questions 5 and 10.

56. Senator KENNEDY. Colonel Warren, did you express your opinions on the preceding four questions, or on any other questions raised by the reports to anyone in any form? To whom and in what form? Please provide copies of any materials in any form containing or reflecting those opinions.

Colonel WARREN. I do not specifically recall to whom I stated my opinion at the time, although I am sure that I commented on the report to officers in my section, and to MP and MI officers. The only documents that I am aware of that could be considered as reflecting an opinion are those referred to in my response to question 5.

AUTHORITY TO TAKE ACTION

57. Senator KENNEDY. Colonel Warren, did you think it was your responsibility as a legal advisor to take remedial action yourself?

Colonel WARREN. Yes. In addition to my responsibility as a legal advisor, I believe it is my duty as a member of the U.S. military to ensure that captured persons are protected and treated humanely. I regret that I did not recommend a more formal inquiry into the allegations of the report. While this would not have prevented the abuse documented in the USACIDC report, which occurred in November, a more formal inquiry might have resulted in an earlier initiation of the CID investigation.

58. Senator KENNEDY. Colonel Warren, did you have authority to take that action? If so, what did you do? Please provide any documentation. If not, whose responsibility did you think it was or to assure that remedial action was taken? Did you inform that person promptly and fully? Please provide documentation.

Colonel WARREN. The primary authority and responsibility to take remedial action rested with the MP commanders of the camps and the facilities, and with their chain of command. Having said that, early on in the war and throughout the fall, in an effort to assist those efforts, I was personally involved, along with my officers, in arranging for and obtaining food, water, shelter (including tents), showers, and other supplies for prisoners, as well as obtaining detention facilities.

PRISONER CATEGORIES AT ABU GHRAIB

59. Senator KENNEDY. Colonel Warren, we have heard that the prisoners at Abu Ghraib fall into three categories: common criminals, EPWs, and security internees. Could you explain the difference between an EPW and a security internee?

Colonel WARREN. An EPW is a person who meets the criteria of a lawful combatant in accordance with the Third Geneva Convention (Geneva Convention Relative to the Treatment of Enemy Prisoners of War, August 12, 1949). In Iraq, a security internee is a person who is a civilian (not meeting prisoner of war criteria) who is interned as an imperative threat to security in accordance with the Fourth Geneva Convention (Geneva Convention Relative to the Treatment of Civilian Persons in Time of War, August 12, 1949). Both EPWs and security internees are "protected persons" under the Geneva Conventions.

60. Senator KENNEDY. Colonel Warren, could you elaborate on what circumstances of capture would lead to a determination that someone is a security internee? Is that decision reviewed, and if so, when?

Colonel WARREN. Authority to capture or detain is stated in the ROE. Upon capture, a person is to be treated humanely and with dignity and respect. Their status is irrelevant. Within 72 hours (until the summer of 2003, 21 days) after induction at a detention facility, a Magistrate reviews the circumstances of capture to determine whether a reasonable basis exists to conclude that the detainee is an imperative threat to security. This review exceeds the legal requirement of the Fourth Geneva Convention, which mandates a review within 6 months of detention. Whether detention should continue is reviewed by the Review and Appeal Board, which also considers appeals from orders of internment.

61. Senator KENNEDY. Colonel Warren, is a security internee an unlawful combatant? If a security internee is an unlawful combatant, does that mean the Geneva Conventions do not apply to them?

Colonel WARREN. Not all security internees are unlawful combatants. An unlawful combatant is a person who engages in hostilities against a lawful combatant without legal privilege. Simply put, legal privilege attaches when a person meets the criteria of Article 4 of the Third Geneva Convention. The significance of this legal privilege is that it means that the person cannot be prosecuted for lawful "warlike acts." While an unlawful combatant can be prosecuted for warlike acts, the Geneva Conventions still apply to them. If captured, they, like security internees who are not unlawful combatants, are protected persons under the Fourth Geneva Convention.

62. Senator KENNEDY. Colonel Warren, does some lesser standard of Geneva Conventions apply to the security internees?

Colonel WARREN. The four Geneva Conventions afford different protections to different categories of individuals. At one end of the spectrum are the protections afforded by the Third Geneva Convention to EPWs during international armed conflict. This includes immunity from all lawful pre-capture acts, and is the highest protection afforded by the Geneva Conventions. The Fourth Geneva Convention applies to civilians, who are afforded many, but not all, of the protections and privileges afforded POWs. Security Internees (persons who present an imperative threat to security) are a category of civilian internees who are afforded fewer protections than civilian internees not suspected of being a security threat. The latter point proceeds from a plain reading of the Fourth Geneva Convention and in Pictet's Commentary to the Geneva Conventions. See, for example, Pictet's comments on "coercion" under Article 31 of the Fourth Geneva Convention.

63. Senator KENNEDY. Colonel Warren, why would the Geneva Conventions apply to unlawful combatants in Iraq, but not in Afghanistan?

Colonel WARREN. The Geneva Conventions apply in Iraq because there was a state of international armed conflict, then occupation, triggering the application of the Conventions by their terms. I refer you to the DOD for an analysis of the applicability of the Geneva Conventions in Afghanistan.

CRITERIA FOR DETERMINING THE STATUS OF PERSONS CAPTURED BY THE UNITED STATES

64. Senator KENNEDY. Colonel Warren, did the United States military change their criteria for determining the status of persons captured by United States military personnel after May 1?

Colonel WARREN. No. The criteria are not set by the military, but by international law. Specifically, in situations such as Iraq where it is applicable, Article 5 of the Third Geneva Convention would require a presumption of POW protection in cases "where status is in doubt." In these cases, POW protections could only be denied based up action by competent tribunal convened under Article 5.

CJTF-7 conducted such tribunals through the summer of 2003 where status of captured personnel was in doubt. POW protections were accorded to Saddam Hussein, captured in December 2003, without action of an Article 5 tribunal because CJTF-7 concluded that his status as a POW was not in doubt.

However, for the majority of persons captured after May 1, the date of the announced end of major combat operations, no doubt existed as to their status as POWs. By May 1, 2003, the Iraqi military had disintegrated and had been abolished by CPA order. U.S. and U.K. military forces were under effective control of Iraqi territory and Iraq was occupied territory. Virtually all persons detained after May 1 simply did not meet the criteria of the Third Geneva Convention as members of the Armed Forces, or of a militia, volunteer corps or levee en masse, in order to be accorded POW status.

65. Senator KENNEDY. Colonel Warren, what was the number of EPWs captured after May 1? How many security detainees have been captured after May 1? If there was a change in criteria after May 1, why does this date have legal significance?

Colonel WARREN. Those numbers are not available to me, but I believe they can be obtained from the National Detainee Reporting System database. The criteria by which we discerned the status of POWs has never changed throughout the conduct of the war and is governed by the Third Geneva Convention. The significance of May 1 is discussed in the response to question 64.

66. Senator KENNEDY. Colonel Warren, were the implications of the change discussed with Pentagon leadership, Pentagon legal counsel, State Department leadership, State Department legal counsel, the White House, or White House legal counsel?

Colonel WARREN. The distinction between international armed conflict and occupation was and is a widely known fact, consistent with applicable international law, specifically the law of war and the law of occupation. The distinction explains the difference between the Third and Fourth Geneva Conventions. It was a matter of continuous discussion and implementation. One example of its implementation is the establishment and operation of the Central Criminal Court of Iraq (CCCI), which has had a number of prosecutions and convictions of unlawful combatants for attacks on coalition forces. Their very status as unlawful combatants makes defendants susceptible to prosecution. Were they POWs, they would be afforded legal privilege (immunity) for their acts. I discussed this matter with the DOD General Counsel and the JAG of the Army, and their staff.

SCOPE OF GENEVA CONVENTION

67. Senator KENNEDY. Colonel Warren, could you please provide a list of all legal and military treatises, texts, authorities, regulations, journals, and manuals that you relied upon as authoritative or informative for defining the scope of the Geneva Conventions relative to limits on interrogation and detention?

Colonel WARREN. To the best of my recollection:

- a. Third Geneva Convention Relative to the Treatment of Enemy Prisoners of War, August 12, 1949.
- b. Fourth Geneva Convention Relative to the Treatment of Civilian Persons in Time of War, August 12, 1949.
- c. The Geneva Conventions of 12 August 1949, Commentary. Jean S. Pictet, 1958.
- d. FM 27-10, The Law of Land Warfare, July 18, 1956.
- e. FM 34-52, Interrogation Intelligence, September 28, 1992.
- f. DA Pam 27-1 Treaties Governing Land Warfare, December 7, 1956.
- g. CENTCOM Reg 27-13, Captured Persons, February 7, 1995.
- h. CFLCC Operations Orders.
- i. CENTCOM Operations Orders.
- j. DOD Directive 2310.1, DOD Enemy POW Detainee Program, August 18, 1994.

- k. SECDEF Memorandum, Subject: Interrogation Techniques in the War on Terrorism (S), April 16, 2003.
- l. AR 190–8, Enemy Prisoners of War, Retained Personnel, Civilian Internees and other Detainees, October 1, 1997.
- m. AR 190–14, Carrying of Firearms and Use of Force for Law Enforcement and Securities Duties, March 12, 1993.
- n. AR 190–40, Serious Incident Report, November 30, 1993.
- o. AR 381–10, U.S. Army Intelligence Activities, July 1, 1984.
- p. Israeli Supreme Court decision on “Torture” (Judgment Concerning the Legality of the General Security Service’s Interrogation Methods).
- q. U.S. Code, Anti-Torture Statutes, 18 USC 2340A/B.

TIME LINE OF CJTF–7 INTERROGATION POLICY

68. Senator KENNEDY. Colonel Warren, could you provide a time line describing the development of the CJTF–7 interrogation and counter resistance policy signed by you on October 12, 2003?

Colonel WARREN. I did not sign the policy, which is a CJTF–7 command policy memorandum.

The following timeline describes the development of the policy:

September 10, 2003: Draft Interrogation and Counter-Resistance Policy memorandum circulated for comment.

September 14, 2003: Policy memorandum issued, provided to CENTCOM for review.

September 14–October 12, 2003: Review of the policy within CJTF–7 and between CJTF–7 and CENTCOM.

September 28, 2003: Second draft circulated for comment.

October 4/5, 2003: Third draft circulated for comment.

October 12, 2003: Final policy memorandum issued.

69. Senator KENNEDY. Colonel Warren, could you provide a time line describing the evolution of the chart provided to the committee by MG Alexander and described as the CJTF–7 Interrogation Rules of Engagement that appear several times in the Taguba report annexes?

Colonel WARREN. I cannot from personal experience. However, I understand that the chart was prepared at Abu Ghraib in late September or October 2003. It was not a CJTF–7 command product.

DETAINEES AT ABU GHRAIB

70. Senator KENNEDY. General Sanchez, were you aware of the number of detainees who were there on average at Abu Ghraib in the fall and winter of 2003? How many?

General SANCHEZ. Yes. A report is forwarded daily to the National Detainee Reporting System database, which is maintained by Headquarters, Department of the Army. During the fall and winter of 2003, the detainee population varied between 5,000 and 6,700.

71. Senator KENNEDY. General Sanchez, were you aware of the number of detainees who were processed in and released on a daily basis? How many?

General SANCHEZ. I was not aware of the number of in-processed and released detainees on a daily basis as the Commanding General, CJTF–7. Periodically I reviewed snapshots of detainee numbers in order to maintain situational awareness of ongoing developments in the detainee population. Examinations of the databases for Abu Ghraib indicate the following numbers in-processed during the months from October 2003 to March 2004:

October – 2,429
 November – 1,980
 December – 2,105
 January – 1,922
 February – 1,143
 March – 961

The daily report of releases may be obtained from the National Detainee Reporting System database, maintained at Headquarters, Department of the Army.

PRISONER TRACKING SYSTEM

72. Senator KENNEDY. General Sanchez, were you aware of the prisoner tracking system at Abu Ghraib?

General SANCHEZ. Yes. At first, a manual tracking system was used, but this was replaced by the Biometric Automated Track Toolset (BATS) system in the latter part of 2003. This system has vastly improved our ability to account for those in the custody of coalition forces.

73. Senator KENNEDY. General Sanchez, were you aware of the problems the military had with keeping track of who was at the prison?

General SANCHEZ. Yes. That is why we transitioned to more technologically advanced systems such as BATS. For several months, we had enormous problems with the identification of detainees. This was caused by difficulties in entering and maintaining the correct data in non-standard databases developed by the 800th MP BDE. Problems ranged from transliteration and disarrangement of detainees' multiple names through misunderstanding of the Arabic language to false names provided by some detainees. Early in the war, some prisoners had no capture tags or documentation. These problems were exacerbated by the use of at least two numbering systems for detainees and maintenance of at least three populations: EPWs, criminal detainees, and security internees.

MILITARY POLICE AT ABU GHRAIB

74. Senator KENNEDY. General Sanchez, did you have sufficient MPs at Abu Ghraib to maintain security and aid in detention operations?

General SANCHEZ. Yes.

INTERROGATION RULES OF ENGAGEMENT

75. Senator KENNEDY. General Sanchez, do you believe that it was appropriate to use the tactics listed on the right hand side of the slide titled "Interrogation Rules of Engagement (IROE)" provided to the Committee by MG Alexander on the prisoners at Abu Ghraib when you didn't even know who was there and if they deserved such treatment?

General SANCHEZ. The IROE slide was not approved or produced by CJTF-7. The slide was prepared by a subordinate command in order to summarize the interrogation and counter-resistance policy. The CJTF-7 interrogation and counter-resistance policy was stated in two memoranda, the first dated September 14, 2003 and the second dated October 12, 2003. Both memoranda were furnished to the committee on May 19, 2004.

The September 14, 2003 policy authorized the methods listed in the right column of the IROE chart, except for "sensory deprivation" and "sleep deprivation." Use of the authorized methods was subject to the general and specific safeguards listed in Enclosure 2 of the Policy, as well as the implementation guidance of the commander, 205th MI BDE. The September policy remained in effect for less than 1 month, until superceded by the October 12, 2003, policy.

The October 12, 2003, policy which remained in effect for 7 months, authorizes the methods listed at its enclosure 1, subject to the safeguards listed at its enclosure 2. These methods do not include sleep deprivation, presence of military working dogs, or excessive noise. Use of any methods not listed at enclosure 1 of the October 12 policy is not authorized without a written exception to policy granted by me, as well as legal review and review by the command's senior intelligence officer. The methods listed in the right column of the IROE chart are similarly not authorized under the October 12 policy.

Except for segregation in excess of 30 days, I have neither received nor approved any requests for the use of any methods requiring an exception to policy. Except for segregation in excess of 30 days, I have not approved the use of any of those methods for a particular prisoner.

Safeguards for all interrogation methods included: limited use of the techniques only by trained personnel; medical evaluations of all candidates prior to employment of interrogation approaches and their combinations; interrogation plans with specific attention to proposed limits on duration, intervals between applications of interrogation approaches, termination criteria, and the presence of qualified medical personnel; appropriate supervision; provision for adequate sleep, food and water; monitoring for adverse medical or psychological effects during segregation; adequate supervision of the use of interrogation approaches.

By its terms, the October 12, 2003, policy enunciates the purpose of interviews and interrogations to obtain the “most information from a security internee with the least intrusive method, applied in a humane and lawful manner with sufficient oversight by trained investigators or interrogators. Further, “Interrogators must ensure the safety of security internees, and approaches must in no way endanger them.”

Additionally, interrogations were subject to a October 5, 2003, command policy memorandum entitled “Proper Treatment of Iraqi People During Combat Operations” which emphasized treatment of all persons under coalition forces’ control, including prisoners and detainees, with dignity, respect, and humanity. This memorandum was reissued by order in January 2004. Similar memoranda and orders were issued in April and March 2004.

Finally, the slide itself reiterates adherence to these standards outlined above: “[a]pproaches must always be humane and lawful, [d]etainees will NEVER be touched in a malicious or unwanted manner—[t]he Geneva Conventions apply within CJTF-7. . . . VIOLATIONS MUST BE REPORTED IMMEDIATELY TO THE OIC.” The slide concludes with the reiteration that the use of all the techniques are subject to general safeguards as well as guidance from the 205th MI BDE Commander, CJTF-7 Commander and FM 34-52, Interrogation Intelligence.

76. Senator KENNEDY. General Sanchez, could you describe your rationale for the development of the October 12 guidance for IROE and the October 5 memorandum on the CJTF-7 Interrogation and Counter Resistance Policy? Are these documents different? If so, how? Please provide copies of both and any earlier drafts of both documents.

General SANCHEZ. The October 12 memorandum was the “Interrogation and Counter-Resistance Policy.” There was no CJTF-7 document termed IROE. There was an October 5, 2003, memorandum entitled, “Proper Treatment of the Iraqi People During Combat Operations.”

The October 12, 2003, memorandum was developed to state the command’s policy on Interrogation and Counter-Resistance. It was preceded by the September 14, 2003, policy on the same subject, and a series of drafts, all of which are enclosed in classified form (enclosures retained in committee files). The October 5, 2003, memorandum on Interrogation and Counter-Resistance was a draft that reflects the process leading to the October 12, 2003, policy.

The October 12 document is very different from the October 5 memorandum. The October 5, 2003, memorandum applies to Interrogation and Counter-Resistance only generally in that it requires the treatment of all persons, including detainees, with dignity, respect, and humanity. There were no prior drafts of this memorandum. The rationale behind the October 12 policy was to ensure that the command had a single interrogation policy that comported with the Geneva Conventions. The rationale behind the October 5 memorandum was to reemphasize to soldiers that they had an obligation to follow the law of war and treat all persons, including detainees, with dignity, respect, and humanity.

77. Senator KENNEDY. General Sanchez, did you adopt General Miller’s recommendations from his September report in your October 5 memorandum? To what extent did you accept General Miller’s recommendations? If you rejected any of his recommendations, could you explain why?

General SANCHEZ. The October 5 memorandum was developed to reinforce the obligation of coalition forces to treat the Iraqi people with dignity, respect and humanity. This obligation specifically extended to detainees. MG Miller’s recommendations had no connection to the drafting or issuance of the October 5 memorandum. A copy of the memorandum is enclosed.

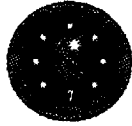

REPLY TO
ATTENTION OF

HEADQUARTERS
COMBINED JOINT TASK FORCE SEVEN
BAGHDAD, IRAQ
APO AE 09338

CJTF7-CG

5 October 2003

MEMORANDUM FOR All Coalition Forces Personnel

SUBJECT: Proper Treatment of the Iraqi People During Combat Operations

1. **Purpose.** This memorandum reemphasizes the responsibility of Coalition Forces to treat all persons under their control with dignity and respect. It reinforces the obligation of Coalition personnel to comply with the law of war.
2. **Humane Treatment of the Iraqi People.** Coalition Forces are committed to restoring the human rights of Iraqi civilians and the rule of law. We must treat all civilians with humanity, dignity, and respect for their property and culture. Coalition Forces preserve human life by avoiding civilian casualties and rendering prompt medical attention to persons injured during combat operations. In all circumstances, treat those who are not taking an active part in hostilities, including prisoners and detainees, humanely. Remain particularly aware of sensitivity concerning females. Whenever possible, females will be searched in a non-public location; unless absolutely necessary, male soldiers will not search females.
3. **Force Protection and the Lawful Use of Force.** We are conducting combat operations in a complex, dangerous environment. Coalition Forces must remain bold and aggressive, yet disciplined, in their use of force. When in contact with the enemy, use only that force necessary to accomplish the mission while minimizing unintended damage. Our posture must be strong and determined, while remaining firmly in control of the destructive power of our weapons. You have learned the principles of the law of war throughout your military careers. As professional soldiers, you must follow them, and comply with the rules of engagement. Before engaging any target, you must be reasonably certain that it is a legitimate military target. Self-defense is always authorized.
4. **Conclusion.** Respect for others, humane treatment of persons not taking part in hostilities, and adherence to the law of war and rules of engagement is a matter of discipline and values. It is what separates us from our enemies. I expect all leaders to reinforce this message.

RICARDO S. SANCHEZ
Lieutenant General, USA
Commanding

There was an October 5, 2003, unsigned draft of the CJTF-7 Interrogation and Counter-Resistance Policy. The draft led to the final policy, issued on October 12, 2003. The promulgation of a command Interrogation and Counter-Resistance Policy was based on the recommendations of MG Miller's assessment. With regard to the observation that CJTF-7 should have a specific interrogation policy, no aspect of MG Miller's recommendation was rejected.

78. Senator KENNEDY. General Sanchez, did you coordinate recommendation of MG Miller with anyone in the Pentagon? Was this policy coordinated with interrogation policies in any other theaters or with any other agencies? Who approved this policy?

General SANCHEZ. I did not coordinate MG Miller's recommendations with anyone in the Pentagon and I am not aware of any such coordination by my staff. I understand that the September 14 Interrogation and Counter-Resistance Policy was modeled on the policy from Guantanamo Bay, modified for use in a theater of war in

which the Geneva Conventions were applicable. I understand that other policies were consulted in the development of the CJTF-7 policy, but I am unaware of any coordination with other agencies.

COPPER GREEN

79. Senator KENNEDY. General Sanchez, I would like to ask you a question that may require a classified response. If such a response is necessary, I would appreciate it if you would provide unclassified and classified answers for the record. Are you aware of the existence of a program that was called "Copper Green"?

General SANCHEZ. No.

SPECIAL ACCESS PROGRAM

80. Senator KENNEDY. General Sanchez, are you aware of any Special Access Program to gather intelligence from detainees at Abu Ghraib?

General SANCHEZ. No.

ASSESSMENT OF DETAINEE OPERATIONS

81. Senator KENNEDY. General Miller, after you completed your assessment of detainee operations on September 9, did you provide recommendations to LTG Sanchez? Did you provide those recommendations to Colonel Pappas?

General MILLER. I gave an outbrief to LTG Sanchez and MG Fast covering those topics covered in the Assessment of DOD Counterterrorism Interrogation and Detention Operations in Iraq (MG Miller Assistance Visit Report). This included recommendations in detention, information management and fusion, and interrogation operations. Colonel Pappas, though present during visits to Abu Ghraib and consulted at Camp Victory, was not provided with a copy of the final report by the assessment team.

[Whereupon, at 12:21 p.m. the committee adjourned.]

**THE DEPARTMENT OF THE ARMY INSPECTOR
GENERAL REPORT ON DETENTION OPER-
ATION DOCTRINE AND TRAINING**

THURSDAY, JULY 22, 2004

U.S. SENATE,
COMMITTEE ON ARMED SERVICES,
Washington, DC.

The committee met, pursuant to notice, at 9:40 a.m. in room SD-106, Dirksen Senate Office Building, Senator John Warner (chairman) presiding.

Committee members present: Senators Warner, McCain, Sessions, Talent, Levin, Kennedy, Reed, Akaka, Bill Nelson, E. Benjamin Nelson, Clinton, and Pryor.

Committee staff members present: Judith A. Ansley, staff director; and Leah C. Brewer, nominations and hearings clerk.

Majority staff members present: Charles W. Alsup, professional staff member; Ambrose R. Hock, professional staff member; Paula J. Philbin, professional staff member; Lynn F. Rusten, professional staff member; Scott W. Stucky, general counsel; and Richard F. Walsh, counsel.

Minority staff members present: Richard D. DeBobes, Democratic staff director; Daniel J. Cox, Jr., professional staff member; Peter K. Levine, minority counsel; and William G.P. Monahan, minority counsel.

Staff assistants present: Alison E. Brill, Andrew W. Florell, and Nicholas W. West.

Committee members' assistants present: Christopher J. Paul, assistant to Senator McCain; John A. Bonsell, assistant to Senator Inhofe; James P. Dohoney, Jr., assistant to Senator Collins; Clyde E. Taylor IV, assistant to Senator Chambliss; Meredith Moseley, assistant to Senator Graham; Christine O. Hill, assistant to Senator Dole; Russell J. Thomasson, assistant to Senator Cornyn; Mieke Y. Eoyang and Jarret A. Wright, assistants to Senator Kennedy; Erik Raven, assistant to Senator Byrd; Elizabeth King, assistant to Senator Reed; Davelyn Noelani Kalipi and Richard Kessler, assistants to Senator Akaka; William K. Sutey, assistant to Senator Bill Nelson; Eric Pierce, assistant to Senator Ben Nelson; Andrew Shapiro, assistant to Senator Clinton; and Terri Glaze, assistant to Senator Pryor.

**OPENING STATEMENT OF SENATOR JOHN WARNER,
CHAIRMAN**

Chairman WARNER. The committee meets today to continue its series of hearings relating to allegations on prisoner abuse and otherwise the manner in which the Department of Defense (DOD), particularly the Department of Army, maintains and conducts its detention and interrogation of the prisoners. This is a very important segment of the U.S. commitment in the ongoing war on global terrorism.

Today's hearing will focus on the Department of Army Inspector General's Detainee Operations Inspection Report that focuses on detention operations, doctrine, and training. I welcome our witnesses this morning: the Honorable Les Brownlee, Acting Secretary of the Army; General Peter J. Schoomaker, Chief of Staff of the United States Army; and Lieutenant General Paul Mikolashek, Inspector General (IG) of the Army. Good morning, gentlemen, and thank you for coming.

General MIKOLASHEK. Good morning, sir.

Chairman WARNER. On February 10, 2004, the Secretary of the Army as executive agent for the Department of Defense, Enemy and Prisoner of War Detention Program, issued a directive for the Army IG to establish an assessment team to complete a functional analysis of the Department's internment, enemy-prisoner of war, and detention policies, practices, and procedures.

Secretary Brownlee took this action after allegations of detainee abuse and inadequate training for soldiers involved in the detention of prisoners came to the Secretary's attention.

I have the full text of that directive here, and I ask that it be placed following my opening statement in the record. It is here for anybody to inspect.

I apologize to my colleague for the short notice about this hearing, but Senator Levin and I feel as these matters become available we should bring them to the attention of our colleagues promptly with a hearing, and we have done so this morning.

I want to thank the Department of Defense and the Department of the Army for making this information available to the committee in a timely and a forthright manner. I have been in consultation with the Secretary for a week or 10 days about the timing, and he assured me that it would be forthcoming as soon as it has been completed, and that has been done. So I thank you, Mr. Secretary.

At a time when the Army is decisively engaged around the world, especially in Iraq and Afghanistan, the Army is also committed to rigorously and thoroughly reviewing its practices and procedures and making constructive adjustment and changes along the way. I commend you, Mr. Secretary, the Chief, and others for that course of action.

As a result of allegations of abuse of prisoners and the related scrutiny of interrogation policy and procedures, the Department has directed 11 senior-level reviews—that is the Department of Defense—in addition to many unit-level reviews and criminal investigations. That list of reviews was provided to the committee at the last hearing, but basically five of these reviews are now complete and have been provided to the committee in their entire text. Five of the remaining six senior-level reviews are estimated to be com-

pleted over the course of the next several months, including the Fay report on interrogation procedures at the Abu Ghraib prison and Dr. Schlesinger's independent review together with Secretary Harold Brown of the DOD detention operation. That review was directed specifically by the Secretary of Defense (SECDEF).

I wish to remind members of the committee that the report that will be presented this morning is not, and I repeat, is not, an investigation of specific allegations of abuse. Rather, it is an IG inspection, which is focused on the adequacy of current Army training and doctrine to prepare soldiers to properly and safely capture, care for, control, and interrogate prisoners in a combat theater of operations.

It is intended to examine the presence or absence of systemic issues, not just individual cases. It must be viewed in that context. It is but one piece of a larger picture, but in my view a very important piece, and it is a timely public disclosure of that piece.

As the committee has conducted its oversight responsibilities, we have learned that detention operations are complex and are not limited to the operation of just prisons. Detention operations start at the moment of capture, often in the heat of battle and the ensuing confusion, and continue through the screening, transportation, interrogation, and in some cases the long-term internment.

Prior to September 11, few people in our military had experience in the detention of prisoners. It was a skill not often practiced. That has changed since operations began in Afghanistan and now continuing through Iraq.

In the case of the Abu Ghraib prison, we have experienced an unacceptable breakdown in military discipline. This represents an extremely rare chapter in the otherwise extraordinary proud history of our Armed Forces. It defies common sense and contradicts all the values that Americans stand for and that our military defends. Once again, I commend the Department of Defense and specifically the Department of the Army for the manner in which it is proceeding under the Uniform Code of Military Justice (UCMJ) to hold those accountable where they have been determined to have broken the Military Code and the Geneva Conventions.

Of our uniformed personnel, 99.9 percent are performing difficult tasks humanely and honorably and in some cases making the ultimate sacrifice of life and limb to win the war on terror. Each of us on the committee has nothing but the strongest support for our brave men and women in uniform and their families.

Congress has the responsibility to get at the facts, to make sure that the conditions that have allowed this misconduct to occur have been identified and corrected, and to ensure that systems are in place so that the misconduct of this type never happens again. But as we conduct our necessary oversight, it is just as important to ensure that the Armed Forces have the ability to vigorously conduct the missions required to defend our Nation and to win the global war on terrorism. Intelligence-gathering is at the very heart of that.

I thank our witnesses for their service and their dedication to do the right thing for the Army and our Nation.

[The information referred to follows:]



DEPARTMENT OF THE ARMY
WASHINGTON DC 20310-0200

February 10, 2004

MEMORANDUM FOR THE INSPECTOR GENERAL

SUBJECT: Directive for Assessment of Detainee Operations

You are hereby directed to establish an Assessment Team to complete a Functional Analysis of the Department's internment, enemy prisoner of war, and detention policies, practices, and procedures as the Army executes its role as DOD Executive Agent for Enemy Prisoners of War and Detention Program.

When conducting this assessment, the following terms of reference apply. Use all potential Doctrine, Operations, Training, Materiel, Leadership, Personnel, and Facilities (DOTMLPF) approaches to identify any capability shortfalls with respect to internment, enemy prisoner of war, detention operations, and interrogation procedures and recommend appropriate resolutions or changes if required.

The assessment will focus on the following objectives:

- a. Assess the adequacy of DOTMLPF of Army Forces for internment, enemy prisoner of war, detention operations, and interrogation procedures.
- b. Determine the standards for Army Forces charged with internment, enemy prisoner of war, detention operations and interrogation procedures (e.g., size, equipment, standardization, and training).
- c. Assess current and future organizations and structures for Army Forces responsible for internment, enemy prisoner of war, detention operations and interrogation procedures.
- d. Identify and recommend any changes in policy related to internment, enemy prisoner of war, detention operations and interrogation procedures.

You are authorized to task the Army Staff and subordinate headquarters for those resources needed to ensure accomplishment of the detainee operations assessment. You are further authorized access to locations, documents, and personnel across the Army in order to complete your assessment. Coordinate with other Services for assistance, documentation, and information that may assist in completing this assessment.

You will provide me with a report at the conclusion of the assessment.

This assessment is exempt from the HQDA Short Notice Tasking Policy Message, dated 031353Z Jan 01, requiring units to be notified 180 days from execution of tasking and the HQDA memorandum dated January 27, 2004, subject: Travel [Restriction] to Iraq, Afghanistan, Kuwait and Qatar which requires my approval to travel to these countries.

R. L. Brownlee
Acting Secretary of the Army

Chairman WARNER. Senator Levin.

STATEMENT OF SENATOR CARL LEVIN

Senator LEVIN. Thank you, Mr. Chairman. Let me join you in welcoming our witnesses and thanking them on behalf of the entire committee for their service to the people of the United States and what we represent.

Today we receive testimony on the Army Inspector General's analysis of the Army's prisoner detention operations doctrine and training.

General Mikolashek, your report examines whether there were systemic problems with detention operations in Iraq and Afghanistan that may have contributed to abuse of detainees in U.S. custody, including the abuses, which were so graphically depicted in photos from Abu Ghraib.

When General Abizaid appeared before this committee in mid-May, he testified that one of the preliminary findings of the Army IG's investigation was that, "Our doctrine is not right." Based on a very quick perusal of the final report, which we just received, it claims that the incidents of abuse in Iraq and Afghanistan were not the result of systematic problems. Nonetheless, the report finds that Army doctrine needs to be adapted to the environment in which our soldiers are working to provide security, and in this regard the report makes over 50 recommendations for improving Army detention operations.

The findings and recommendations of this report will need to be closely examined in light of the additional allegations of abuse and legal and policy memoranda that have emerged in the last few months. This additional information includes the February 2004 International Committee of the Red Cross (ICRC) report, which documents a wide variety of "methods of ill treatment" in the detention and interrogation of detainees in Iraq. It reports that these methods were used "in a systematic way," and, quoting again from the ICRC February 2004 report, "appeared to be part of the standard operating procedures by military intelligence personnel to obtain confessions and extract information."

Interrogation techniques witnessed by the ICRC during their visits to Abu Ghraib appear consistent with techniques that we now

know were approved and later rescinded by high-level Defense Department officials or by in-theater commanders in Iraq. In light of the frequently changing "rules of engagement," as they were called, for interrogations in Iraq, Afghanistan, and elsewhere, it is difficult to believe that there were not systemic problems with our detention and interrogation operations.

The report that we receive today is the first of a half dozen reports that we expect to receive over the next several weeks, including a report from Generals Fay and Jones on the role of military intelligence personnel at Abu Ghraib. Each of these reports will be helpful to us and the Nation in understanding what really happened with the detainees in Iraq.

I look forward to your testimony. I also want to thank our chairman because he continues to pursue the reports and to schedule hearings, when appropriate, when these reports are received. Very strong oversight by this committee is surely appropriate under the circumstances we face.

Thank you very much, Mr. Chairman.

Chairman WARNER. Thank you, Senator Levin. Again, in consultation with you we have arranged today in S-407 of the Capitol to have additional matters relating to the ICRC available for inspection by members and such other material as has been made available by the Department relative to the overall question of the prisoners throughout the world.

Secretary Brownlee, we welcome you before our committee, that you remember with, I hope, great fondness. You were our Chief of Staff under a series of chairmen. We just admire so much your work in the Department of Defense, your love for the United States Army, the men and women in uniform and their families, and the around-the-clock care that you try to provide for your family in the Army. Thank you, sir, for your service.

STATEMENT OF HON. LES BROWNLEE, ACTING SECRETARY OF THE ARMY; ACCOMPANIED BY GEN PETER J. SCHOOMAKER, USA, CHIEF OF STAFF OF THE ARMY; AND LTG PAUL T. MIKOLASHEK, USA, INSPECTOR GENERAL OF THE ARMY

Mr. BROWNLEE. Mr. Chairman, Senator Warner; Senator Levin; and distinguished members of the committee, I appreciate the opportunity to be here today along with our Chief of Staff of the Army, General Schoomaker, and our Inspector General, General Paul Mikolashek. I might add, sir, that the lavish praise that you just heaped on me should be spread among all these people in uniform and those serving around the world, because it is their service and sacrifice that really counts.

Chairman WARNER. You have followed that same message ever since you were a platoon leader.

Mr. BROWNLEE. Which I might still should be doing, sir.

But we are here this morning, sir, to offer testimony on the Department of Army Inspector General's report on the detention operations. When I last appeared before you on 7 May to testify about detainee abuses at Abu Ghraib, the Inspector General's inspection was ongoing. It is now complete.

Let me begin by emphasizing again that this is a report of an assessment of detention operations across the Central Command

area of operations. It is not the result of an investigation of a single incident.

In mid-January 2004, credible reports led senior commanders in the Central Command area of responsibility to begin investigations into allegations of detainee abuse at Abu Ghraib Prison. Concerned that there might be systemic problems in the planning, doctrine, or training of how the Army was conducting detention operations in Central Command, on 10 February I directed the Inspector General of the Army, Lieutenant General Paul Mikolashek, to conduct a functional analysis of the Department's internment, enemy prisoner of war, and detention policies, practices, and procedures.

General Mikolashek conducted a thorough and balanced inspection in the following 5 months. He and his team looked at ongoing detention operations in Central Command with assessment visits to 16 detention facilities in that theater. During the course of their inspection, they interviewed some 650 soldiers, noncommissioned officers, and officers.

Three key findings emerged based on this inspection: First, all the leaders and soldiers interviewed by General Mikolashek and his team understand the requirement and obligation to treat all detainees humanely, and they are doing so.

Second, while the inspection revealed some deficiencies, shortfalls, and required adjustments, we were unable to identify system-wide failures that resulted in incidents of abuse. This inspection indicates that these incidents of abuse resulted from the failure of individuals to follow known standards of discipline and Army values and in some cases the failure of a few leaders to enforce these standards of discipline.

Third, just as the current operational environment demands that we adapt, so too we must adapt our organization, doctrine, and training. We are making these adjustments.

General Mikolashek's team concentrated on two key components of detention operations: the capture, security, and humane treatment of the detainees; and the conduct of interrogation operations in order to gain useful intelligence. While he did not find any systemic failures that led directly to the abusive situations we reviewed, his report makes recommendations to improve the effectiveness of detention operations. We are reviewing those recommendations. We are implementing them as quickly as possible.

It is worth noting that our soldiers are conducting operations under demanding, stressful, and dangerous conditions against enemies who do not follow the Geneva Conventions, who take hostages and ruthlessly execute them, who maim and kill noncombatants indiscriminately and without remorse, who fight from inside mosques and other protected sites.

Our soldiers are in an environment that demands significant volumes of human intelligence, particularly at the tactical level, where the need for this actionable intelligence is most critical to protect our forces and the intelligence itself is most perishable.

They understand their duty to treat detainees humanely and in accordance with the laws of land warfare and report incidents of abuse when they occur. I am proud of our soldiers, as I know all of you are. They are indeed doing their duty every day under harsh, difficult, dangerous conditions, and the allegations and re-

ports of abuse have in many cases come from the soldiers themselves, who saw something wrong and informed their chain of command.

We have developed, trained, and educated our leaders to adapt to the environments in which they find themselves. They understand their tasks, conditions, and standards and to the best of their abilities and capabilities have adapted their tactics, techniques, and procedures to accommodate this operational environment.

Institutionally, we are expanding our doctrine on detainees to provide our commanders greater flexibility and adaptability within well-defined principles. Our training and education at the individual, unit, installation level, and institutional levels must continue to be thorough and reflect the intensity of the environment in which we now operate.

During the course of his inspection, General Mikolashek's team noted that since October 2001 U.S. forces have detained some 50,000 individuals in Afghanistan and Iraq. As of June 9, 2004, which was the cutoff date for General Mikolashek's report, there were 94 cases of confirmed or possible abuse of any type, which include theft, physical assault, sexual assault, and death. The Army has initiated criminal investigations into these allegations and, where appropriate, legal action has been and will be taken.

The Inspector General's review of all reported cases of abuse determined that these incidents resulted from the failure of individuals to follow known standards of discipline and Army values and, in some cases, the failure of a few leaders to enforce those standards of discipline. These incidents are not representative of Army policy, doctrine, or soldier training. These actions, while regrettable, are aberrations when compared to the actions of the hundreds of thousands of our soldiers who have served and continue to serve around the world with distinction and honor.

Mr. Chairman, all of you are aware that these incidents of detainee abuse have occurred. Army soldiers and leaders were involved in these incidents, and the Army is responsible for their actions. As the senior civilian official in the Army, I accept this responsibility.

Mr. Chairman, I appreciate this opportunity to appear before this distinguished committee today. I thank you and the members of the committee for your continuing support of our men and women in the Army, and we look forward to answering your questions.

Let me just say as I yield to my friend here what a great pleasure it is to serve every day with General Pete Schoomaker. He brings such great leadership to the Army and our soldiers, and I am so proud just having the honor on a daily basis to work with a soldier like this.

Chairman WARNER. I share those views.

Mr. Secretary—General, if you will just wait a minute—you and I met earlier this morning on a subject, which is not directly before the committee today, and that is the reported problems with the Army budget. I wonder if you would just provide the committee with a brief synopsis of what we discussed because one or more members may wish, given the opportunity here to have you this morning, to probe into this budget matter. I think you can bring some clarity to it.

Mr. BROWNLEE. Yes, sir. The article certainly reflects that there are continuing demands for resources through our efforts in Iraq and Afghanistan. The Department has met with us and the other Secretaries, Chiefs, and the staff of the Office of the Secretary of Defense (OSD) has worked closely with us. A plan was in place and we have all taken actions to defer some things into the next fiscal year where possible.

But also, we want to be sure and express our sincere appreciation to the members of this committee and the entire Congress because the appropriations bill, the defense appropriations bill that is now before the Senate and we hope will pass today. This bill has within it a \$25 billion bridge supplemental, which includes a provision that will make that \$25 billion accessible to the Department upon enactment of the bill, which is a little unusual. Normally it would be available at the first of the fiscal year.

But Congress, recognizing the demand for resources, the situation we were in, and some of the deferrals we were making, recognized this and took steps. Sir, we are greatly appreciative.

Chairman WARNER. I hope you can assure us that this shortfall has not in any way affected the combat operations or deprived any soldier, sailor, or airman working with the Army of the means by which to carry out their missions?

Mr. BROWNLEE. Sir, to my knowledge there is no shortfall anywhere as a result of these kinds of issues. We would ensure that that did not happen.

Chairman WARNER. Thank you.

General Schoomaker.

General SCHOOMAKER. Sir, thank you very much.

Chairman WARNER. You also joined in the discussion with the Secretary this morning, and I presume you can give us the same assurances?

General SCHOOMAKER. Sir, I can, and I would just amplify the Secretary's comments there, that the Department of Defense helped us with the corporate decision of a little more than \$4 billion to fulfill—

Chairman WARNER. Added it to your cash?

General SCHOOMAKER. Added it to us, to ensure the continuity of operations and that we did not have to do things that were not in our best interests. So we appreciate their support as well.

Sir, thank you very much for your kind statements. Chairman Warner, Secretary Levin, distinguished members of the committee, I appreciate the opportunity to appear here today with Secretary Brownlee and with General P.T. Mikolashek.

We currently have more than one million soldiers in the Army and more than 300,000 of them are deployed around the globe in over 120 countries. The vast majority of our soldiers are performing their duties with honor, dignity, courage, and respect.

We are, have been, and will remain a value-based institution. When I was sworn in as Chief of Staff in August of last year, I said our values will not change. That was true in August, and it is true today. Our values will not change, and they are nonnegotiable. Our soldiers are warriors of character. They exemplify our values every day and are the epitome of the American spirit. They are the heart of our Army.

As the Chief of Staff of the Army, as the senior uniformed officer in the Army, I am responsible to train and equip soldiers and grow leaders. I am also responsible to provide ready and relevant land power to the combat commanders and the joint team. Although I am not in the operational chain of command, I am responsible for our soldiers' readiness, and it has been made very clear over the last couple of months that we could have prepared our soldiers better, and I feel a great deal of responsibility for the actions of our soldiers, both good and bad.

Having said that, I believe the inexcusable behavior of a few is not representative of the courageous and compassionate performance of the majority of our soldiers. The IG report confirms that belief. As the Secretary has already stated, the report focuses on the training, material, leadership, personnel, facilities, standards, force structure, and policy. It identifies what went right as well as where we could do better as related to the internment of enemy prisoners of war and other detention operations and intelligences procedures. It also recommends actions to begin addressing the identified shortfalls right away.

Commanders and leaders at every level have a duty to respect the established international laws of armed conflict, to treat those within our military detention facilities with dignity and decency in the same ways that we expect to be treated as Americans. This inspection shows that our commanders and leaders in nearly every case know this and did this.

Abuses that did occur by a few have hit at the very core of the values of our institutions, caused us grave concern, and prompted us to take a very focused and thorough review of this matter. I am pleased that the Inspector General has completed this very important review.

In our Army we expect all soldiers to demonstrate the basic core values of dignity and respect for others, to include those we have detained. We remain steadfastly committed to dealing expeditiously with any complaint or allegation of mistreatment, and I am confident that our commanders have been taking appropriate action.

Thank you very much.

Chairman WARNER. Thank you very much.

General Mikolashek.

General MIKOLASHEK. Chairman Warner, Senator Levin, I appreciate the opportunity to speak to you and the members of this committee on this important subject. As has already been mentioned, the Secretary did direct us on February 10 to conduct this functional analysis of how the Army conducted detention operations in the context of our doctrine, organization, current and future organizations, training material, leadership, and soldiers, and recommend changes to those as we saw fit.

While this inspection began with this directive on 10 February, the Army had already begun to assess detention operations internally. An assessment of interrogation operations as well as an assessment by the Provost Marshal General regarding corrections operations in theater had been completed. Further, commanders of forward-deployed units were using their own inspectors general to conduct assessments of detention operations in both Afghanistan and Iraq. While a catalyst for this specific inspection was the ini-

tial report of the crime at Abu Ghraib, we had been looking at these processes for some time.

This inspection represents one of several ongoing inspections and investigations. It is not a criminal investigation. The Criminal Investigation Department (CID) will continue to conduct investigations into the specific crimes involving detainee abuse. This inspection does not seek to find culpability or fix responsibility regarding questionable activity by military intelligence personnel, as the Procedure 15 report seeks to accomplish that task.

This inspection, as previously stated, was not an investigation of a particular incident or a unit or solely focused on abuse, but a comprehensive, broad examination of all our systems that influence the conduct of these operations in both Iraq and Afghanistan and how the Army prepares and supports its soldiers in the execution of these tasks.

We approached this mission with an eye toward the future by offering recommendations as to how the Army can adjust its doctrine, organizational structures, training, and other key systems. To some degree, it does represent a snapshot in time. Even during the conduct of our visits, we noticed continual adjustments and improvements by the commanders and soldiers in the field. Many of the recommendations contained in this report are already being acted upon.

We conducted this inspection, as the Secretary mentioned, through the use of interviews, sensing sessions, surveys of over 650 soldiers from private to major general. We visited sites from the point of capture to the internment and resettlement facilities in both Afghanistan and Iraq. We visited our combat training centers at Fort Polk and Fort Irwin, as well as the Army's Survival, Evasion, Resistance, and Escape Training Center. We visited units and soldiers who had redeployed to the continental United States (CONUS) and Reserve component soldiers who were demobilizing who had been conducting detention operations in theater. We visited the Military Intelligence School, the Military Police School, as well as reviewed all known previously conducted reports and investigations regarding detention operations.

We also analyzed 125 case summaries of alleged abuse in an effort to establish a pattern, a trend, or a root cause. We did conduct a thorough review of the systems affecting detention operations through the eyes of the soldiers and the leaders who are tasked with executing those operations. We looked for systemic issues and problems, and we defined a systemic problem as one that is widespread or presents a pattern. We attempted to determine what problems exist within these systems and to determine if any directly related to abuse.

This report must also be taken in context of the world in which our soldiers are operating. We see that this is a tough, demanding, dangerous, and different environment that is in a constant state of flux. The enemy we face is ruthless and determined, who seeks to accomplish their objectives through terror, murder and intimidation. They seek to hide among the people and gain support from the populace as well as from external sources. They adapt as we adapt.

This environment puts a tremendous burden on our soldiers who confront this enemy and their supporters eyeball-to-eyeball every day. You will see our soldiers have responded to this challenge very well.

This kind of battlefield puts a premium on knowing the enemy in detail on virtually a personal basis, and thus a premium on human intelligence, particularly at the tactical level.

In order to examine these operations, we determined that there are fundamentally two components of detention operations: first, the capture, care, and control of detainees; and second, the interrogation process itself. These components enable the goals of detention operations: first, to keep the enemy off the battlefield in a humane and secure manner; and then to gain intelligence from those who would do us harm.

In summary, during our inspection we found that, as the Secretary mentioned, our soldiers and leaders do understand the requirement to treat people humanely. They are doing so. They also understand their duty obligation to report incidents of abuse and they do so. They also have done a remarkable job of adjusting their procedures to the environment that I described.

While we did find shortcomings and flaws in each of the systems we looked at, we also found that in our analysis of those abusive situations that did occur they were not the result of any widespread systemic failure. In those cases that we reviewed, the result was of an individual's failure to adhere to known standards of discipline, training, or Army values, or in some cases an individual failure that was accompanied by the failure of a leader to enforce discipline, provide supervision and oversight.

We found that the current operational environment puts demands on our soldiers and leaders to adapt rapidly, and they are doing so. We saw that our soldiers and leaders, when confronted with the difficult and unexpected, responded exactly the way they should have: creatively, rapidly, and aggressively. Our leader development doctrine and process produced these leaders who are unafraid to take risks and, despite a wide range of adversities and uncertainty, adapted and are getting the job done.

Our training doctrine teaches that we train to a task, condition, and a standard. But when the conditions become so different new tasks are created, our soldiers and leaders must respond and react, and they are doing so today.

However, as I mentioned, not all of these systems function perfectly and, just as our soldiers and leaders in the field are adapting, our doctrinal, organization, and training systems must also continue to adapt to support these soldiers in these kinds of operations.

Throughout the report we identify 8 significant findings, 15 other observations, and suggest 52 recommendations that, when implemented, will assist our soldiers and commanders in accomplishing their mission. I will discuss the major findings in the context of the two key components of detention operations.

Regarding the capture, care, and control of detainees, as I previously mentioned, we find that commanders, soldiers, and leaders at all levels throughout the process do treat them properly and emphasize the importance of doing so. We found that leaders are visi-

ble during the conduct of detention operations from the point of capture up through the internment and resettlement operations. We found that soldiers are aware of that responsibility to report infractions and they do report them. In fact, during the course of our inspection five soldiers came forward and reported to my inspectors incidents of abuse.

We examined all known cases of abuse that had been reported in Army channels as of June 9, 2004. As of that time, there were 125 reports of abuse cases. We recognize that since that time other reports of alleged abuse have come forward and you have probably seen a different set of numbers, and those differences can be accounted for by the time gap since our data cutoff and what has gone on since then. Our information only includes Afghanistan and Iraq, not Guantanamo. Our reports are based on those made to the Army CID or to Army units as of that cutoff date of June 9.

Having said that, for the purpose of our analysis the use of the all known reports at that time, the study of those 125 cases does provide us a solid basis for analysis in an effort to determine if there was a pattern, a root cause, or perhaps a systemic failure.

As mentioned before, we found that the abuse that did occur, based on a review of those incidents, it was the result of an individual failure of discipline or compounded by the actions or failure of actions of a leader at the tactical level to enforce those standards of discipline, provide the right kind of oversight and supervision.

We defined "abuse" as wrongful death, assault, sexual assault, or theft. As of June 9, we had reviewed 103 summaries of completed and ongoing CID investigations and 22 unit investigations conducted by the chain of command, hence the 125 total.

Not all of the investigations are closed, but nevertheless we attempted, based on the information we had, to categorize each of them in order to identify a pattern. We separated the 125 cases into two categories where it was determined through the course of the investigation that no abuse had occurred. There were 31 of those cases, leaving 94 that abuse was confirmed, that was possible, or that was in an unknown or undetermined category.

As the Secretary mentioned, this number must be taken in the context of the estimated 50,000 detainees that had been under U.S. control for some period of time, not to mention the volume and number of contacts with Iraqi people through checkpoints, patrols, and other operations. We view the 50,000 as a conservative estimate.

We then associated each case with a location on the battlefield. We determined that nearly half the cases, 45 out of the 94, took place at the point of capture. Of note, 20 of those 45 cases were theft and 25 had some element of physical abuse associated with them. The point of capture is the place on the battlefield that is the most uncertain, dangerous, and violent.

Most of the allegations of abuse that occurred at the point of capture were the result of actions by a soldier or soldiers who failed to maintain their self-discipline or follow procedures when dealing with recently captured detainees. Some were a reflex or impulse action on the part of the detainee or the part of the soldier. There are a few incidents that clearly show criminal activity.

Twenty-one of the cases took place at internment and resettlement facilities, including the highly publicized case at Abu Ghraib. There were 19 incidents that occurred at division and brigade level collection points throughout the battlefield. Our review of those cases also establishes that abuse was caused by an individual or individuals acting criminally or failing to follow the known standards, or the failure of a leader to be involved and intercede to stop potentially abusive situations from occurring.

There are nine other cases for which the location precision of what happened is unknown or undetermined, and that accounts for the 125.

Our report also identified several other findings regarding security, administration, medical support, organization, training, regarding the capture, care, and control of detainees.

We also examined and inspected all the four internment and resettlement facilities and found among all of them only Abu Ghraib was in an undesirable location based on its proximity to hostile fire and the location near an urban area.

Regarding interrogation operations, we looked at the process and the necessity to gain valuable information from those we detain. We recognize that this environment has placed a premium on human intelligence, particularly at the tactical level. We found that our commanders recognized this quickly and adapted their procedures in an effort to meet this demand. They realized the necessity to hold detainees long enough at the tactical level to take advantage of the knowledge that both the command has of the environment and the possible information that the detainee may have.

The commanders then must provide, however, for their security, medical care, accountability of the detainees and then be able to conduct more extensive questioning interrogation at that tactical level.

We found that our doctrine must be expanded to further define the relationship between military police (MP) and military intelligence (MI). Both must understand not only their roles, but also the roles and limitations of the other.

We also must provide our commanders more precise guidance on how to establish and operate joint-interrogation facilities. We found that our commanders need more interrogators and interpreters, particularly at the tactical level, and that contract interrogators, while providing considerable value, must be trained on military interrogation techniques, procedures, and policy.

We found that our tactical intelligence officers have the need to conduct complex human intelligence missions and must be able to manage the full spectrum of human intelligence (HUMINT) assets that are being used now in this current environment. Our training of these officers must be expanded to include these types of operations.

We reviewed the existing command policies developed for the conduct of interrogations to determine their compliance with law and policy. We found that the approved command policies regarding interrogation approach techniques developed for Operations Enduring Freedom (OEF) and Iraqi Freedom (OIF), along with the published safeguards, were generally consistent with law and policy. We also found, however, that training and oversight of these

policies was inconsistent, but could also find no confirmed instance involving the application of an approved approach technique that led to abuse.

We also identified another series of observations. We provide recommendations that will clarify our policy, expand our doctrine, verify our ongoing organizational efforts, improve the living conditions for our soldiers and detainees, and refine our training to support these operations and better enable our commanders to accomplish the mission in its current environment and into the foreseeable future.

Our recommendations have been reviewed and an action plan has been developed that tasks the Army staff and the subordinate commands for further review and implementation.

I appreciate the opportunity to provide this summary of our report and look forward to your questions. Thank you.

[The Department of the Army Inspector General's Detainee Operations Inspection follows:]

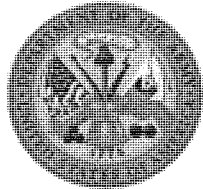

**DEPARTMENT OF THE ARMY
THE INSPECTOR GENERAL**

Detainee Operations Inspection



21 July 2004

691



DEPARTMENT OF THE ARMY
WASHINGTON DC 20310

JUL 21 2004

MEMORANDUM FOR CHIEF OF STAFF, ARMY

SUBJECT: Department of the Army Inspector General Inspection Report on Detainee Operations

I approve the Department of the Army Inspector General Inspection Report on Detainee Operations dated 21 July 2004.

I direct:

- a. As an exception to policy, the unclassified portion of this report be released, without redactions, through posting on the Army website.
- b. Findings and recommendations concerning Central Command be forwarded through the Joint Staff to Central Command for consideration.
- c. The Director of the Army Staff task the appropriate Army Staffs and major Army commands with implementing the recommendations specified in the inspection report and then track their compliance.
- d. The Department of the Army Inspector General disseminate the inspection report to the Army leadership.

R. L. Brownlee
Acting Secretary of the Army

FOREWORD

This inspection report responds to the Acting Secretary of the Army's 10 February 2004 directive to conduct a functional analysis of the Army's conduct of detainee and interrogation operations to identify any capability shortfalls with respect to internment, enemy prisoner of war, detention operations, and interrogation procedures and recommend appropriate resolutions or changes if required.

Based on this inspection:

-- the overwhelming majority of our leaders and Soldiers understand the requirement to treat detainees humanely and are doing so.

-- we were unable to identify system failures that resulted in incidents of abuse. These incidents of abuse resulted from the failure of individuals to follow known standards of discipline and Army Values and, in some cases, the failure of a few leaders to enforce those standards of discipline.

-- the current operational environment demands that we adapt; our Soldiers are adapting; so we must also adapt our doctrine, organization, and training.

We examined the two key components of detainee operations: the capture, security and humane treatment of the detainees; and the conduct of interrogation operations in order to gain useful intelligence. While we did not find any systemic failures that directly led to the abusive situations we reviewed, we have made recommendations to improve the effectiveness of detainee operations.

We found that Soldiers are conducting operations under demanding, stressful, and dangerous conditions against an enemy who does not follow the Geneva Conventions. They are in an environment that puts a tremendous demand on human intelligence, particularly, at the tactical level where contact with the enemy and the people are most intense. They do understand their duty to treat detainees humanely and in accordance with laws of land warfare. These Soldiers understand their obligation to report incidents of abuse when they do occur, and they do so. Our leaders have been developed, trained and educated to adapt to the environment in which they find themselves. They understand their tasks, conditions and standards. The conditions of the current operations have caused them to adapt their tactics, techniques and procedures within their capabilities to accommodate this operational environment.

Expanding our doctrine to provide commanders flexibility and adaptability within well-defined principles will better enable them to conduct these operations. Our training and education systems at the individual, unit, and institutional levels must continue to be thorough and realistically simulate the intensity of the environment in which we now operate.

While the primary purpose of this inspection was not to examine specific incidents of abuse, we did analyze reported incidents to determine their root or fundamental causes. To provide a context for the incidents, we noted that an estimated 50,000 individuals were detained for at least some period of time by U.S. Forces during the conduct of OPERATION ENDURING FREEDOM and OPERATION IRAQI FREEDOM. U.S. Forces' contact with the local populace at checkpoints, on patrols, and in other situations increases the number of contacts well in excess of this 50,000 estimate. As of 9 June 2004, there were 94 cases of confirmed or possible abuse of any type, which include, theft, physical assault, sexual assault, and death.

The abuses that have occurred are not representative of policy, doctrine, or Soldier training. These abuses should be viewed as what they are - unauthorized actions taken by a few individuals, and in some cases, coupled with the failure of a few leaders to provide adequate supervision and leadership. These actions, while regrettable, are aberrations when compared to the actions of fellow Soldiers who are serving with distinction.

Table of Contents

<u>Section</u>	<u>Page</u>
Table of Contents	
Executive Summary	i
Chapter 1 - Background and Inspection Concept	1
Chapter 2 - Inspection Methodology	5
Chapter 3 - Capture, Care, and Control of Detainees	13
Chapter 4 - Interrogation Operations	27
Chapter 5 - Other Observations	43
Chapter 6 - Summary of Recommendations	91
Appendix A - References	A-1
Appendix B - Assessment Directive	B-1
Appendix C - Locations Visited	C-1
Appendix D - Inspection Tools	D-1
Appendix E - Standards	E-1
Appendix F- Abbreviations and Acronyms	F-1

Executive Summary

Detainee Operations

1. **Background:** On 10 February 2004, the Acting Secretary of the Army directed the Department of the Army Inspector General (DAIG) to conduct an assessment of detainee operations in Afghanistan and Iraq. In order to satisfy this directive, the DAIG inspected internment, enemy prisoner of war, detention operations, and interrogation procedures in Afghanistan and Iraq. The inspection focused on the adequacy of Doctrine, Organization, Training, Materiel, Leadership, Personnel, and Facilities (DOTMLPF), standards, force structure, and policy in support of these types of operations.

This inspection was not an investigation of any specific incidents or units but rather a comprehensive review of how the Army conducts detainee operations in Afghanistan and Iraq.

The DAIG did not inspect the U.S. military corrections system or operations at the Guantanamo Bay Naval Base during this inspection. Central Intelligence Agency (CIA) and Defense HUMINT Services (DHS) operations were not inspected.

2. **Purpose:** Conduct a functional analysis of the Army's internment, enemy prisoner of war, detention operations, and interrogation procedures, policies, and practices based on current Department of Defense and Army policies and doctrine. The inspection is to identify any capability and systemic shortfalls with respect to internment, enemy prisoner of war, detention operations, and interrogation procedures and recommend appropriate resolutions or changes if required.

3. **Concept:** Two teams conducted inspections of 26 locations in Iraq, Afghanistan, and the Continental United States (CONUS). The CONUS team consisted of seven personnel, including augmentees, and visited 10 locations while the OCONUS team consisted of nine personnel, including augmentees, and inspected 16 locations. We interviewed and surveyed over 650 leaders and Soldiers spanning the ranks from Private to Major General. We also reviewed 103 reports of allegations of abuse from Criminal Investigation Division (CID) and 22 unit investigations that covered the period from September 2002 to June 2004.

4. **Objectives:** The DAIG Team had four objectives for the inspection:

- a. Assess the adequacy of DOTMLPF of Army Forces for internment, enemy prisoner of war, detention operations, and interrogation procedures.
- b. Determine the standards for Army Forces charged with internment, enemy prisoner of war, detention operations and interrogation procedures (e.g., size, equipment, standardization, and training).
- c. Assess current and future organizations and structures for Army Forces responsible for internment, enemy prisoner of war, detention operations and interrogation procedures.
- d. Identify and recommend any changes in policy related to internment, enemy prisoner of war, detention operations and interrogation procedures.

5. Synopsis:

In the areas that we inspected, we found that the Army is accomplishing its mission both in the capture, care, and custody of detainees and in its interrogation operations. The overwhelming majority of our leaders and Soldiers understand and adhere to the requirement to treat detainees humanely and consistent with the laws of land warfare. Time and again these Soldiers, while under the stress of combat operations and prolonged insurgency operations, conduct themselves in a professional and exemplary manner.

The abuses that have occurred in both Afghanistan and Iraq are not representative of policy, doctrine, or Soldier training. These abuses were unauthorized actions taken by a few individuals, coupled with the failure of a few leaders to provide adequate monitoring, supervision, and leadership over those Soldiers. These abuses, while regrettable, are aberrations when compared to their comrades in arms who are serving with distinction.

The functional analysis of the Army's internment, enemy prisoner of war, detention operations, and interrogation procedures, policies, and practices can be broken down into two main functions: (1) capture, care, and control of detainees, and (2) interrogation operations.

We determined that despite the demands of the current operating environment against an enemy who does not abide by the Geneva Conventions, our commanders have adjusted to the reality of the battlefield and, are effectively conducting detainee operations while ensuring the humane treatment of detainees. The significant findings regarding the capture, care, and control of detainees are:

- All interviewed and observed commanders, leaders, and Soldiers treated detainees humanely and emphasized the importance of the humane treatment of detainees.
- In the cases the DAIG reviewed, all detainee abuse occurred when one or more individuals failed to adhere to basic standards of discipline, training, or Army Values; in some cases abuse was accompanied by leadership failure at the tactical level.
- Of all facilities inspected, only Abu Ghraib was determined to be undesirable for housing detainees because it is located near an urban population and is under frequent hostile fire, placing Soldiers and detainees at risk.

We determined that the nature of the environment caused a demand for tactical human intelligence. The demands resulted in a need for more interrogators at the tactical level and better training for Military Intelligence officers. The significant findings regarding interrogation are:

- Tactical commanders and leaders adapted their tactics, techniques, and procedures, and held detainees longer than doctrinally recommended due to the demand for timely, tactical intelligence.
- Doctrine does not clearly specify the interdependent, and yet independent, roles, missions, and responsibilities of Military Police and Military Intelligence units in the establishment and operation of interrogation facilities.
- Military Intelligence units are not resourced with sufficient interrogators and interpreters, to conduct timely detainee screenings and interrogations in the current

operating environment, resulting in a backlog of interrogations and the potential loss of intelligence.

- Tactical Military Intelligence Officers are not adequately trained to manage the full spectrum of the collection and analysis of human intelligence.
- Officially approved CJTF-7 and CJTF-180 policies and the early CJTF-180 practices generally met legal obligations under U.S. law, treaty obligations and policy, if executed carefully, by trained soldiers, under the full range of safeguards. The DAIG Team found that policies were not clear and contained ambiguities. The DAIG Team found implementation, training, and oversight of these policies was inconsistent; the Team concluded, however, based on a review of cases through 9 June 2004 that no confirmed instance of detainee abuse was caused by the approved policies.

We reviewed detainee operations through systems (Policy and Doctrine, Organizational Structures, Training and Education, and Leadership and Discipline) that influence how those operations are conducted, and have identified findings and recommendations in each. While these findings are not critical, the implementation of the corresponding recommendations will better enable our commanders to conduct detainee operations now and into the foreseeable future, decrease the possibility of abuse, and ensure we continue to treat detainees humanely.

The findings and observations from this inspection are separated into the following three chapters: Chapter 3 - Capture, Care, and Control of Detainees, Chapter 4 - Interrogation Operations, and Chapter 5 - Other Observations. A summary of the Capture, Care, and Control of Detainees and the Interrogation Operation findings is provided below.

Capture, Care, and Control of Detainees

Army forces are successfully conducting detainee operations to include the capture, care, and control of detainees. Commanders and leaders emphasized the importance of humane treatment of detainees. We observed that leaders and Soldiers treat detainees humanely and understand their obligation to report abuse. In those instances where detainee abuse occurred, individuals failed to adhere to basic standards of discipline, training, or Army Values; in some cases individual misconduct was accompanied by leadership failure to maintain fundamental unit discipline, failure to provide proper leader supervision of and guidance to their Soldiers, or failure to institute proper control processes.

We found through our interviews and observations conducted between 7 March 2004 and 5 April 2004 that leaders and Soldiers in Afghanistan and Iraq were determined to do what was legally and morally right for their fellow Soldiers and the detainees under their care. We found numerous examples of military professionalism, ingrained Army Values, and moral courage in both leaders and Soldiers. These leaders and Soldiers were self-disciplined and demonstrated an ability to maintain composure during times of great stress and danger. With the nature of the threat in both Afghanistan and Iraq, Soldiers are placed in extremely dangerous positions on a daily basis. They face the daily risks of being attacked by detainees, contracting communicable diseases from sick detainees, being taunted or spat upon, having urine or feces thrown upon them, and having to treat a detainee humanely who just attacked their unit or killed a fellow Soldier. Despite these challenges, the vast majority of Soldiers and other U.S. Military personnel continued to do their duty to care for detainees in a fair and humane manner.

Our review of the detainee abuse allegations attempted to identify underlying causes and contributing factors that resulted in abusive situations. We examined these from the perspective

of the Policy and Doctrine, Organizational Structures, Training and Education, and Leadership and Discipline systems. We also examined them in terms of location on the battlefield and sought to determine if there was a horizontal, cross-cutting system failure that resulted in a single case of abuse or was common to all of them. Based on this inspection, we were unable to identify system failures that resulted in incidents of abuse. These incidents of abuse resulted from the failure of individuals to follow known standards of discipline and Army Values and, in some cases, the failure of a few leaders to enforce those standards of discipline. We also found that our policies, doctrine, and training are being continually adapted to address the existing operational environment regarding detainee operations. Commanders adjusted existing doctrinal procedures to accommodate the realities of the battlefield. We expect our leaders to do this and they did. The Army must continue to educate for uncertain environments and develop our leaders to adapt quickly to conditions they confront on the battlefield.

Using a data cut-off of 9 June 2004 we reviewed 103 summaries of Army CID reports of investigation and 22 unit investigation summaries conducted by the chain of command involving detainee death or allegations of abuse. These 125 reports are in various stages of completion. 31 cases have been determined that no abuse occurred; 71 cases are closed; and 54 cases are open or undetermined. Of note, the CID investigates every occurrence of a detainee death regardless of circumstances.

Recognizing that the facts and circumstances as currently known in ongoing cases may not be all-inclusive, and that additional facts and circumstances could change the categorization of a case, the Team placed each report in a category for the purposes of this inspection to understand the overall numbers and the facts currently known, and to examine for trends or systemic issues. This evaluation of allegations of abuse reports is not intended to influence commanders in the independent exercise of their responsibilities under the Uniform Code of Military Justice (UCMJ) or other administrative disciplinary actions. As an Inspector General inspection, this report does not focus on individual conduct, but on systems and policies.

This review indicates that as of 9 June 2004, 48% (45 of 94) of the alleged incidents of abuse occurred at the point of capture, where Soldiers have the least amount of control of the environment. For this inspection, the DAIG Team interpreted point of capture events as detainee operations occurring at battalion level and below, before detainees are evacuated to doctrinal division forward or central collecting points (CPs). This allowed the DAIG Team to analyze and make a determination to where and what level of possible abuse occurred. The point of capture is the location where most contact with detainees occurs under the most uncertain, dangerous, and frequently violent circumstances.

This review further indicates that as of 9 June 2004, 22% (21 of 94) of the alleged incidents of abuse occurred at Internment/Resettlement (I/R) facilities. This includes the highly publicized incident at Abu Ghraib. Those alleged abuse situations at I/R facilities are attributed to individual failure to abide by known standards and/or individual failure compounded by a leadership failure to enforce known standards, provide proper supervision, and stop potentially abusive situations from occurring. As of 9 June 2004, 20%, (19 of 94) of the alleged incidents of abuse occurred at CPs. For the remaining 10% (9 of 94) of the alleged incidents of abuse, a location could not be determined based on the CID case summaries.

*Note For the purpose of this inspection, we defined abuse as wrongful death, assault, sexual assault, and theft.

The Army estimates that over 50,000 detainees have been captured or processed. While even one case of abuse is unacceptable, we conclude that given the volume of detainees and the potential for abuse in these demanding circumstances, the overwhelming majority of our Soldiers and leaders are conducting these operations with due regard for the detainees right to be treated humanely and properly.

Detainee abuse does not occur when individual Soldiers remain disciplined, follow known procedures, and understand their duty obligation to report abusive behavior. Detainee abuse does not occur when leaders of those Soldiers who deal with detainees enforce basic standards of humane treatment, provide oversight and supervision of detainee operations, and take corrective action when they see potentially abusive situations developing. Our site visits, interviews, sensing sessions, and observations indicate that the vast majority of Soldiers and leaders, particularly at the tactical level, understand their responsibility to treat detainees humanely and their duty obligation to report infractions.

We inspected I/R facilities at Bagram, Baghdad, and Camp Bucca and found only Abu Ghraib overcrowded, located near a densely populated urban area, on a dangerous main supply route, and subject to frequent hostile enemy fire from enemy mortars or rockets. The physical design of the camps within the prison was not optimal for the mission: towers were not properly placed to support overlapping fields of fire and cover blind spots; entrance/egress routes were hampered by make-shift gates; and sally ports were not used correctly. The supply of fresh water was difficult to maintain and the food quality was sub-standard. Detainees did not have access to bunkers or shelters with overhead cover to protect them from hostile enemy mortar or rocket fire from outside the walls of Abu Ghraib.

Interrogation Operations

The need for timely, tactical human intelligence is critical for successful military operations particularly in the current environment. Commanders recognized this and adapted by holding detainees longer at the point of capture and collecting points to gain and exploit intelligence. Commanders and interrogators also conducted tactical questioning to gain immediate battlefield intelligence. Commanders and leaders must set the conditions for success, and commanders, leaders, and Soldiers must adapt to the ever changing environment in order to be successful.

Of the interviewed point of capture battalion and company leaders, 61% (25 of 41) stated their units established CPs and held detainees at their locations from 12 hours up to 30 days. The primary reason units held detainees at these locations was to conduct screenings and interrogations closer to the point of capture. The result of holding detainees for longer timeframes at all locations was increased requirements in facility infrastructure, medical care, preventive medicine, trained personnel, logistics, and security. Organic unit personnel at these locations did not have the required institutional training and were therefore unaware of or unable to comply fully with Army policies in areas such as detainee processing, confinement operations, security, preventive medicine, and interrogation.

Doctrine does not clearly and distinctly address the relationship between the MP operating I/R facilities and the Military Intelligence (MI) personnel conducting intelligence exploitation at those facilities. Neither MP nor MI doctrine specifically defines the interdependent, yet independent, roles, missions, and responsibilities of the two in detainee operations. MP doctrine states MI may collocate with MP at detention sites to conduct interrogations, and coordination should be made to establish operating procedures. MP doctrine does not,

however, address approved and prohibited MI procedures in an MP-operated facility. It also does not clearly establish the role of MPs in the interrogation process. Conversely, MI doctrine does not clearly explain MP internment procedures or the role of MI personnel within an internment setting. Contrary to MP doctrine, FM 34-52, Intelligence Interrogation, 28 September 1992, implies an active role for MPs in the interrogation process: "Screeners coordinate with MP holding area guards on their role in the screening process. The guards are told where the screening will take place, how EPWs and detainees are to be brought there from the holding area, and what types of behavior on their part will facilitate the screenings." Subordination of the MP custody and control mission to the MI need for intelligence can create settings in which unsanctioned behavior, including detainee abuse, could occur. Failure of MP and MI personnel to understand each other's specific missions and duties could undermine the effectiveness of safeguards associated with interrogation techniques and procedures.

Doctrine that addresses the establishment and operation of interrogations contains inconsistent guidance on terminology, structure, and function of these facilities. At the time of the inspection there were facilities in OPERATION ENDURING FREEDOM and OPERATION IRAQI FREEDOM that conducted intelligence exploitation as Joint Interrogation Facilities and as a Joint Interrogation and Debriefing Center. The intelligence sections of each were uniquely structured to meet mission requirements.

Shortfalls in numbers of interrogators and interpreters, and the distribution of these assets within the battlespace, hampered human intelligence (HUMINT) collection efforts. Valuable intelligence—timely, complete, clear, and accurate—may have been lost as a result. Interrogators were not available in sufficient numbers to efficiently conduct screening and interrogations of the large numbers of detainees at collecting points (CPs) and internment/resettlement (I/R) facilities, nor were there enough to man sufficient numbers of Tactical Human Intelligence Teams (THTs) for intelligence exploitation at points of capture. Interpreters, especially those Category II personnel authorized to participate in interrogations, were also in short supply. Units offset the shortage of interrogators with contract interrogators. While these contract interrogators provide a valuable service, we must ensure they are trained in military interrogation techniques and policy.

Due to the demand for immediate tactical intelligence, tactical intelligence officers were conducting interrogations of detainees without thorough training on the management of HUMINT analysis and collection techniques. They were not adequately trained to manage the full spectrum of HUMINT assets being used in the current operating environment. The need for these officers to understand the management of the full spectrum of HUMINT operations is a key for successful HUMINT exploitation in the current operating environment.

Current interrogation doctrine includes 17 interrogation approach techniques. Doctrine recognizes additional techniques may be applied. Doctrine emphasizes that every technique must be humane and be consistent with legal obligations. Commanders in both OEF and OIF adopted additional interrogation approach technique policies. Officially approved CJTF-180 and CJTF -7 generally met legal obligations under U.S. law, treaties and policy, if executed carefully, by trained soldiers, under the full range of safeguards. The DAIG Team found that some interrogators were not trained on the additional techniques in either formal school or unit training programs. Some inspected units did not have the correct command policy in effect at the time of inspection. Based on a review of CID case summaries as of 9 June 2004, the team was unable to establish any direct link between the proper use of an approved approach technique or techniques and a confirmed case of detainee abuse.

6. Conclusion: The Army's leaders and Soldiers are effectively conducting detainee operations and providing for the care and security of detainees in an intense operational environment. Based on this inspection, we were unable to identify system failures that resulted in incidents of abuse. This report offers 52 recommendations that are designed to improve the ability of the Army to accomplish the key tasks of detainee operations: keep the enemy off the battlefield in a secure and humane manner, and gain intelligence in accordance with Army standards.

Chapter 1

Background and Inspection Concept

1. **Background:** On 10 February 2004, the Acting Secretary of the Army directed the Department of the Army Inspector General (DAIG) to conduct an assessment of detainee operations in Afghanistan and Iraq. In order to satisfy the Acting Secretary of the Army's directive, the DAIG inspected internment, enemy prisoner of war, detention operations, and interrogation procedures in Iraq and Afghanistan. The inspection focused on the adequacy of Doctrine, Organization, Training, Materiel, Leadership, Personnel, and Facilities (DOTMLPF), standards, force structure, and policy.

2. **Inspection Concept:** The detailed concept for this inspection is as follows:

a. **Purpose:** The purpose of this inspection was to conduct a functional analysis of detainee operations based on current Department of Defense (DoD) and Army policy and doctrine.

b. **Objectives:**

(1) Assess the adequacy of DOTMLPF of Army Forces for internment, enemy prisoner of war, detention operations, and interrogation procedures.

(2) Determine the standards for Army Forces charged with internment, enemy prisoner of war, detention operations and interrogation procedures (e.g., size, equipment, standardization, and training).

(3) Assess current and future organizations and structures for Army Forces responsible for internment, enemy prisoner of war, detention operations and interrogation procedures.

(4) Identify and recommend any changes in policy related to internment, enemy prisoner of war, detention operations and interrogation procedures.

c. **Scope:** Two teams conducted inspections of 25 locations in Iraq, Afghanistan, and the Continental United States (CONUS). The CONUS team consisted of seven personnel, including augmentees, and visited seven locations while the OCONUS team consisted of nine personnel, including augmentees, and inspected 16 locations. We interviewed and surveyed over 650 leaders and Soldiers spanning the ranks from Private to Major General. We also reviewed 103 reports of allegations of abuse from Criminal Investigation Division (CID) and 22 unit investigations that cover the period of September 2002 to June 2004.

d. **Focus:** The inspection focused on the functional analysis of the Army's internment, enemy prisoner of war, and detention policies, practices, and procedures as the Army executes its role as the DoD Executive Agent for Enemy Prisoners of War and Detention Program. Numerous DoD Policies, Army Regulations, and Army Field Manuals provided the guiding tenets for this inspection.

e. **Task Organization:** Two teams from the DAIG Inspections Division, with augmentation from the Office of the Provost Marshal General (OPMG), Office of the Judge Advocate General (OTJAG), Office of the Surgeon General (OTSG), U.S. Army Maneuver Support Center

(USAMANSCEAN), U.S. Army Criminal Investigation Command (USACIC), U.S. Army Special Operations Command (USASOC), and the U.S. Army Intelligence Center (USAIC) conducted the inspection by traveling to 25 locations in CONUS and OCONUS. The composition of these teams was as follows:

Inspector General

CONUS

Team Chief IG
Detailed IG
Detailed IG
Assistant IG
Expert from OTSG
Expert from OPMG
Expert from USACIC (Assistant IG)

OCONUS

Team Chief IG
Operation Officer IG
Detailed IG
Detailed IG
Expert from USASOC
Expert from OTJAG
Expert from USAIC
Expert from USAMANSCEAN (Assistant IG)
Expert from OPMG

f. Inspection Process:

- (1) Preparation Phase: Research and Training (February - March 2004)
- (2) Execution Phase: On-Site Inspections (March - April 2004)
- (3) Completion Phase: Final Report Preparation (April - June 2004)

g. Inspection Locations and Schedule: See Appendix C.

h. Inspection Approach: The Inspectors General (IG) for Combined Forces Land Component Command (CFLCC), Combined Joint Task Force-7 (CJTF-7), Combined Joint Task Force-180 (CJTF-180), and local IGs served as coordinating agents for all DAIG inspection activities at those locations. These IGs were telephonically and electronically notified by DAIG with the Notification Memorandum and Detailed Inspection Plan that was sent to all affected Commanders/IGs on 20 February 2004.

i. Other Reports: This report mentions the Ryder Report, Miller Report, and Taguba Investigation throughout its inspection results. These two reports and investigation deal with the following: the Ryder Report is an assessment of detention and corrections operations in Iraq; the Miller Report is a classified assessment of the Department of Defense's counterterrorism interrogation and detention operations in Iraq; and the Taguba Investigation is a classified investigation under Army Regulation 15-6 into the 800th Military Police (MP) Brigade's detention and internment operations.

j. Definitions: The DAIG used the following definitions throughout the report.

(1) The DAIG defined the term "detainee operations" as the range of actions taken by Soldiers beginning at the point of capture, the movement of detainees through division forward and central collecting points (CPs), to internment at internment/resettlement (I/R) facilities, and release. This includes the administrative and medical processing of detainees, medical treatment of detainees, sanitary conditions at I/R facilities and CPs, and interrogation procedures. The term "detainee operations" does not apply to confined U.S. Military personnel.

(2) Army Regulation (AR) 190-8, Enemy Prisoners of War, Retained Personnel, Civilian Internees and Other Detainees, 1 October 1997, defines the term detainee as "any person captured or otherwise detained by an armed force." The DAIG uses the term as defined by AR 190-8 in this report. The term "detainee" includes enemy prisoners of war (EPWs), retained persons (RP), civilian internees (CIs), and other detainees (ODs). When making a differentiation between the different classifications of detainees, the report will specifically mention EPWs, RPs, CIs, or ODs. The report will also point out the use of non-doctrinal terms sometimes used as detainee classifications.

(3) The battlespace of OPERATION ENDURING FREEDOM (OEF) and OPERATION IRAQI FREEDOM (OIF) included an enemy that deployed asymmetrically with adaptive tactics; a battlespace in which there was not always a clear forward line of troops, massing of forces, or an identifiable rear area to which detainees could be rapidly evacuated. The battlespace of OEF and OIF was non-linear with combat and stability operations taking place simultaneously throughout the areas of operation. Combatants included both uniformed and non-uniformed state and non-state sponsored forces who fought using conventional and non-conventional methods to include terrorist actions against both military and civilian targets. Detainees were, and continue to be, more than compliant civilian internees and enemy prisoners of war. They are primarily a noncompliant hostile population that requires more intensive screening, interrogation and segregation. The Army is in a new and unique operational environment stemming from the need for immediate tactical level intelligence coupled with the significant numbers of non-traditional combatants/detainees encountered.

(4) We define a problem as systemic if it is widespread and presents a pattern. We attempted through observations, sensing sessions, interviews, site visits, surveys, and reviews of documents, other reports, and investigations to identify failures in the systems that comprise detainee operations.

[Next page intentionally left blank]

Chapter 2

Inspection Methodology

The Department of the Army Inspector General (DAIG) Team developed a baseline approach to the inspection that focused on gathering information and data from five primary domains: interviews, sensing sessions, document reviews, surveys of commanders, leaders, and Soldiers, and site visits. This approach allowed the Team to glean perceptions and attitudes about detainee operations from selected individuals and populations; to assess detainee operations in doctrinal manuals, unit policies, unit Standing Operating Procedures (SOPs); and to determine compliance with Department of Defense (DoD) and Army policies. The Team visited U.S. Armed Forces-controlled internment/resettlement (I/R) facilities and division central and forward collecting points (CPs), as well as units conducting patrol missions, to gather overall trends and observations on detainee operations from point of capture to the processing conducted at U.S. Armed Forces-controlled I/R facilities.

This baseline methodology afforded the Team a standard, systematic approach to conducting an inspection at each location, which proved essential since the DAIG Team conducted split operations with two teams that traveled separately to continental United States (CONUS) and outside the continental United States (OCONUS) locations. The Team had to tailor their trips to look at units that had already returned from OPERATION ENDURING FREEDOM (OEF) and OPERATION IRAQI FREEDOM (OIF) as well as those units currently deployed.

The methodology established a three-phase plan for executing the inspection.

a. **Phase 1: Preparation.** This phase included travel planning, pre-deployment training, administrative requirements, a review of documents the Team requested in advance from the unit IGs, pre-inspection visits to the National Training Center (NTC) at Fort Irwin and the Joint Readiness Training Center (JRTC) at Fort Polk, and development of a detailed inspection plan.

b. **Phase 2: Execution.** This phase outlined the physical execution of the itinerary developed by the local IG in accordance with the Detailed Inspection Plan. Each visit began with an inbrief to the unit's senior leadership and ended with an outbrief. The DAIG Team conducted interviews, sensing sessions, and a survey of Commanders, leaders and Soldiers currently in the area of responsibility (AOR) and those who recently returned from OEF and OIF to determine detainee operations tactics, techniques, and procedures from point of capture to arrival at the CPs; inspected CPs from receipt of detainees to the transfer of detainees to U.S. Armed Forces-controlled I/R facilities; inspected U.S. Armed Forces-controlled I/R facilities and operations; and reviewed policies, plans, records, programs, Standard Operating Procedures (SOPs), and other related documents.

c. **Phase 3: Completion.** The DAIG Team returned to home station and conducted post-trip data analyses of the information gathered. The Team then crafted detailed trip reports of the visit that captured the critical information gleaned from the trips. These trip reports formed the basis from which the Team developed the findings outlined in the report. Additionally, team members cross-walked information and traveled to the MI and MP schools for coordination and confirmation of information used in the findings.

The following section outlines the baseline methodology in detail to include the specific requirements for interviews and sensing sessions based upon the type of unit visited.

a. **Inspection Methodology.** The local IG served as the coordinating agent for all DAIG inspection activities. The coordinating agent worked with his or her respective DAIG Team point of contact (POC) to develop an itinerary for a four-day inspection for CONUS units and a 30-day period for OCONUS. The coordinating agent and DAIG Team POC fine-tuned the itinerary to maximize the Team's ability to meet the inspection's baseline requirements.

b. Personnel Interviewed:

(1) OCONUS

(a) The Team conducted interviews at CFLCC, CJTF-7, CJTF-180, U.S. Armed Forces-controlled I/R facilities, and division CPs. The Team interviewed selected leaders from CFLCC/CJTF/division/brigade/battalion staffs and company level personnel. Individual interviews occurred in the interviewee's office or in a similar location free from interruptions and telephone calls. The coordinating agent scheduled these interviews to last no more than 1.5 hours. The coordinating agent also considered geographical dispersion and travel times between events. The interviews were conducted by one or two DAIG Team members with the unit interviewee.

(b) The DAIG Team conducted sensing sessions at each U.S. Armed Forces-controlled I/R facility, division CPs, and at the company level, one for junior enlisted (Private through Specialist, but not including Corporals) and one for junior noncommissioned officers (Sergeant and Staff Sergeant). Units provided eight to twelve Soldiers per session. Each sensing session required a classroom or similar facility that was removed from the unit's normal work location. The area was relatively quiet and free from interruptions and telephone calls. In addition, the room needed no less than 14 chairs or desks formed in a circle or square. The coordinating agent scheduled 1.5-hour time blocks for each sensing session. The sensing sessions were conducted by two DAIG Team members with the unit Soldiers.

(c) The coordinating agent adjusted the interview schedule, in coordination with the Team, based upon the availability of personnel. The Team recognized that only full-time Manning personnel might be available in Reserve Component units.

(d) The matrix below was a strawman that was finalized by the DAIG Team POC and the local IG for the OCONUS inspection.

Interviewee/ Sensing Session Requirements	CFLCC	CJTF	DIV COLL Point	BDE COLL Point	Co	MP BDE /BN	US Military Controlled/ Oversight Det Fac
SJA			1			1	1
G2/S2 (for HUMINT purposes)	1	1	1	1		1	1
S1 (if involved with detainee processing)						1	1

SURGEON/ME D OFF	1	1	1	1		1	1
PMO	1	1	1				
CHAPLAIN			1	1		1	1
ENGINEER/S4		1	1	1		1	1
CDR/OIC			1	1	1	1	1
1SG/NCOIC			1	1	1	1	1
S3						1	
INTERROGAT OR (depending where they are located)			3	3			3
GUARD (E1-4) SENSING SESSION			1 EA (8- 12 SOLDIE RS)	1 EA (8-12 SOLDIERS)			1 EA (8-12 SOLDIER S)
GUARD (E5-6) SENSING SESSION			1 EA (8- 12 SOLDIE RS)	1 EA (8-12 SOLDIERS)			1 EA (8-12 SOLDIER S)
GUARD (NCOIC)			1	1			1
SECURITY FORCE (E1-4) SENSING SESSION							1 EA (8-12 SOLDIER S)
SECURITY FORCE (E5-6) SENSING SESSION							1 EA (8-12 SOLDIER S)
SECURITY FORCE NCOIC							1
INFANTRY BDE XO				1			
INFANTRY BN XO				1			
INFANTRY Co CDR/1SG				1			
PREVENTIVE MED INSP			1	1			1
COLL PT MP PLT LDR			1	1			
COLL PT MP PLT SGT			1	1			
UNIT PLT LDR INVOLVED WITH CAPTURE OF PERSONNEL					2		

UNI PLT SGT INVOLVED WITH CAPTURE OF PERSONNEL					2		
UNIT SOLDIERS INVOLVED WITH CAPTURE OF PERSONNEL (E1-4) SENSING SESSION					2 EA (8-12 SOLDIERS) PER COLLECTING POINT		
UNIT SOLDIERS INVOLVED WITH CAPTURE OF PERSONNEL (E5-6) SENSING SESSION					2 EA (8-12 SOLDIERS) PER COLLECTING POINT		

(2) CONUS

(a) The Team conducted interviews of division, brigade, battalion, and company level personnel. The Team interviewed selected leaders from each of these type units. Individual interviews occurred in the interviewee's office or in a similar location that was free from interruptions and telephone calls. The coordinating agent scheduled these interviews to last no more than 1.5 hours. The coordinating agent considered geographical dispersion and travel times between events. The interviews were conducted by one or two Team members with the unit interviewee.

(b) The DAIG Team conducted sensing sessions with collecting point and I/R facility guards and with Soldiers who captured personnel during OEF and OIF. Sensing sessions included one for junior enlisted (Private through Specialist, but not including Corporals) and one for junior noncommissioned officers (Sergeant and Staff Sergeant). Units provided eight to twelve Soldiers per session. Each sensing session required a classroom or similar facility that was removed from the unit's normal work location. The area was relatively quiet and free from interruptions and telephone calls. In addition, the room needed no less than 14 chairs or desks formed in a circle or square. The coordinating agent scheduled 1.5-hour time blocks for each sensing session. The sensing sessions were conducted by two Team members with the unit Soldiers.

(c) The coordinating agent adjusted the interview schedule, in coordination with the Team, based upon the availability of personnel. The Team recognized that only full-time manning personnel might be available in Reserve Component units.

(d) The matrix below was a strawman that was finalized by the DAIG Team POC and the local IG for the CONUS inspection.

Interviewee/Sensing Session Requirements	DIV/SEP BDE	BDE	BN	Co
INFANTRY CDR			1	1
INFANTRY CSM/1SG			1	1
INFANTRY XO		1		
MP CDR/XO	1		1	
MP S4	1		1	
PMO	1			
COLL PT GUARDS (E1-4) SENSING SESSION				1 EA (8-12 SOLDIERS)
COLL PT GUARDS (E5-6) SENSING SESSION				1 EA (8-12 SOLDIERS)
GUARD (NCOIC)				1
DSA/BSA CDR (if coll pt was is in DSA/BSA)			2	
COLL PT MP PLT LDR				1
COLL PT MP PLT SGT				1
UNIT PLT LDR INVOLVED WITH CAPTURE OF PERSONNEL			2	
UNIT PLT SGT INVOLVED WITH CAPTURE OF PERSONNEL			2	
UNIT SOLDIERS INVOLVED WITH CAPTURE OF PERSONNEL (E1-4) SENSING SESSION				2 EA (8-12 SOLDIERS)
UNIT SOLDIERS INVOLVED WITH CAPTURE OF PERSONNEL (E5-6) SENSING SESSION				2 EA (8-12 SOLDIERS)
CHAPLAIN	1	1	1	

d. Administrative Support Requirements. The DAIG Team conducted this inspection with minimal disruption to ongoing unit missions. The Team required special arrangements from the field Inspectors General (IGs), including assistance with country clearances, travel in the AOR, in-country travel, sleeping arrangements, convoy security arrangements, body armor, weapons and ammunition, communications, scheduling of inbriefs and outbriefs, interviews and sensing sessions, and an appropriate work space for up to nine personnel conducting DAIG business.

e. Documents Reviewed In Advance (OCONUS Only):

- (1) All inspections related to detainee operations, including command products, Inspector General products, Criminal Investigative Division(CID), legal, etc.
- (2) All case histories of punishment (judicial and non-judicial) relating to detainee abuse.
- (3) Past and current Rules of Engagement (ROE).

f. Documents Reviewed on Site (OCONUS Only):

- (1) Unit TACSOPs relating to detainee operations (e.g., 5Ss and T, collecting point procedures, and inventorying EPW belongings).
- (2) U.S. Armed Forces-controlled I/R facility SOPs.
- (3) I/R BDE/BN/CO unit manning documentation.
- (4) DD Form 2745 (EPW Capture Tag) log.
- (5) DD Form 629 (Receipt for Prisoner or Detained Person) log.
- (6) DA Form 4137 (Receipt for Evidence/Property Custody Document) log.
- (7) DD Form 2708 (Receipt of Inmate/Detained Person) log.
- (8) DD Form 1594 (Duty Logs).
- (9) U.S. Armed Forces-controlled I/R facilities reporting system database.
- (10) Facility maintenance and repair documentation.
- (11) Facility security SOP.
- (12) Detainee in/out-processing documentation.

g. Documents Reviewed During Inspections (CONUS Only):

- (1) Unit Tactical Standing Operating Procedures (TACSOP) relating to detainee operations (e.g., 5Ss and T, collecting point procedures, and inventorying EPW belongings).
- (2) U.S. Armed Forces-controlled I/R facility SOPs.

(3) I/R Brigade (BDE)/Battalion (BN)/Company (Co) unit manning documentation.

h. Inspection Itineraries. DAIG requested each coordinating agent develop a draft itinerary that met the requirements listed in paragraph b. DAIG requested the coordinating agent include the necessary travel time between scheduled locations. The DAIG Team POC and the coordinating agent developed an itinerary that allows the DAIG Team to meet the objectives listed in Chapter 1 paragraph 2b. The DAIG Team conducted an inbrief with the senior commander/representative at each location.

[Next page intentionally left blank]

Chapter 3

Capture, Care, and Control of Detainees

1. **Summary of Findings:** Army forces are successfully conducting detainee operations to include the capture, care, and control of detainees. Commanders and leaders emphasized the importance of humane treatment of detainees and, currently, leaders and Soldiers treat detainees humanely and understand their obligation to report abuse. In those instances where detainee abuse occurred, individuals failed to adhere to basic standards of discipline, training, or Army Values; in some cases individual misconduct was accompanied by leadership failure to maintain fundamental unit discipline, failure to provide proper leader supervision and guidance to their Soldiers, or failure to institute proper control processes.

For the purpose of this inspection, we defined abuse as wrongful death, assault, battery, sexual assault, sexual battery, or theft. As of 9 June 2004 we had reviewed 103 summaries of Criminal Investigative Division (CID) reports of investigation and 22 unit investigation summaries conducted by the chain of command involving detainee death or alleged abuse. These 125 reports are in various stages of completion. No abuse was determined to have occurred in 31 cases; 71 cases are closed; and 54 cases are open or undetermined. Of note, the CID investigates every occurrence of a detainee death regardless of circumstances. While recognizing that any abuse incident is one too many, we conducted a review and categorization of the summary reports of the 125 investigations. Based on our review and analysis of reports and case summaries of investigations and our observations and interviews conducted throughout this inspection, we could not identify a systemic cause for the abuse incidents. The DAIG uses the term "systemic" specifically to describe a problem if it is widespread and presents a pattern. As defined by the DAIG in this report, a systemic issue may be found either horizontally across many various types of units, or vertically through many command levels or within systems. The DAIG determined that incidents where detainees were allegedly mistreated occurred as isolated events. In a few incidents, higher ranking individuals up to Lieutenant Colonel were involved; however, the chain of command took action when an allegation of detainee abuse was reported.

Abu Ghraib had problems with deteriorating infrastructure that impacted the clean, safe, and secure working environment for Soldiers and living conditions for detainees. Poor food quality and food distribution, lack of laundry capability, and inadequate personal hygiene facilities affected the detainees' living conditions. Overcrowding, frequent enemy hostile fire, and lack of in-depth force protection measures also put Soldiers and detainees at risk.

2. Findings:

a. Finding 1:

(1) **Finding:** All interviewed and observed commanders, leaders, and Soldiers treated detainees humanely and emphasized the importance of the humane treatment of detainees.

(2) **Standard:** See Appendix E.

(3) Inspection Results: The DAIG Team conducted numerous interviews and sensing sessions with leaders and Soldiers that revealed most leaders and Soldiers have treated detainees humanely and would report detainee abuse if they became aware of it.

For OPERATION ENDURING FREEDOM(OEF), Chairman Joint Chiefs of Staff(CJCS) Message dated 211933Z JAN 02, stated that Al Qaida and Taliban would be treated humanely and, to the extent appropriate and consistent with military necessity, in a manner consistent with the principles of the Geneva Conventions. Therefore, most detainees were classified as civilian internees (CIs) (sub-classified for OEF by the following non-doctrinal terms: Persons Under U.S. Control (PUC), Enemy Combatant (EC), and Low-level Enemy Combatant (LLEC)). Interviews, sensing sessions, and document reviews revealed that most Soldiers were aware of their requirement to treat detainees humanely. In most cases, the present level of treatment exceeded the Common Article 3 standard of treatment. Notwithstanding, while detainee abuse had occurred in OEF in the past, the DAIG Team observed that units currently conducting detainee operations missions treated detainees humanely.

Many noncommissioned officers (NCOs) stated very clearly that the humane treatment of detainees was paramount to the success of the mission. Another group of junior enlisted Soldiers stated that they received substantial training on detainee treatment. They went on to specifically mention that they were taught to treat detainees with dignity and respect. In another sensing session, the NCOs stated that the minimum standard for treating detainees is protection, respect, and humane treatment. Some went on to say that violations are not tolerated by the command or fellow Soldiers.

Consistent with these statements, the DAIG Team that visited Iraq and Afghanistan discovered no incidents of abuse that had not been reported through command channels; all incidents were already under investigation. The DAIG Team that visited units recently returning from Iraq did receive a total of 5 new allegations of potential abuse that occurred prior to January 2004. The DAIG Team immediately turned these over to the chain of command and Army Criminal Investigation Division (CID). There is no evidence of the cover-up of current detainee abuse by U.S. Soldiers. This is consistent with the results of the teams' sensing sessions; all currently deployed Soldiers were aware of their responsibility to report abuse and appeared to be willing and able to report any potential abuse.

In OIF, U.S. Forces detained the full spectrum of classes of detainees, but most were classified as EPWs or CIs. Presently, CIs make up the vast majority of the U.S.-controlled detainee population. EPWs are entitled to all the protections in the Geneva Convention Relative to the Treatment of Prisoners of War (GPW), and CIs are entitled to relevant protections in the Geneva Convention Relative to the Protection of Civilian Persons in Time of War (GC). The GPW and GC provide detailed levels and standards of treatment for EPWs and CIs that include treatment during armed conflict and occupation. Most leaders and Soldiers treated EPWs and CIs humanely and consistent with the Geneva Conventions (GPW and GC).

The Army estimates that over 50,000 detainees have been captured or processed. While even one case of abuse is unacceptable, we conclude that given the volume of detainees and the potential for abuse in these demanding circumstances, the overwhelming majority of our Soldiers and leaders are conducting these operations with due regard for the detainees right to be treated humanely and properly.

Detainee abuse does not occur when individual Soldiers remain disciplined, follow known procedures and understand their duty obligation to report abusive behavior. Detainee

abuse does not occur when leaders of those Soldiers who deal with detainees enforce basic standards of humane treatment, provide oversight and supervision of detainee operations and take corrective action when they see potentially abusive situations developing. Our site visits, interviews, sensing sessions and observations indicate that the vast majority of Soldiers and leaders, particularly at the tactical level, understand their responsibility to treat detainees humanely and their duty obligation to report infractions.

The GC and GPW require that copies of the GC be posted in the detainees' language in facilities that contain EPWs and/or CIs. Only 25% (4 of 16) facilities inspected maintained copies of the Geneva Conventions in the detainees' language. No facilities in Afghanistan complied with this Geneva requirement, while only 4 facilities in Iraq were compliant. Other specific details of treatment outlined in the GPW and GC are covered elsewhere in this report.

The DAIG Team observed that units made efforts to comply with the DoD requirement to treat the detainees consistent with the Geneva Conventions. Some of the improvements being made by units and resourceful individuals include: increased training for key noncommissioned officers (NCOs) and small unit leaders; developing standing operating procedures (SOPs); and requesting copies of the Geneva Conventions in the detainees' language for posting.

In general, the Miller Report recognized that detainees should be secured in a humane environment and that greater involvement by judge advocates was required. The DAIG Team did not observe a dedicated judge advocate for interrogation operations, but did note that the MI brigades, assigned to duty at Abu Ghraib, were each assigned at least 1 brigade judge advocate. The Ryder Report stated EPWs and CIs should receive the full protections of the Geneva Conventions unless the denial of these protections was due to specifically articulated military necessity.

The Taguba Investigation observed that many Soldiers and units upheld the Army Values. The Taguba Investigation also detailed numerous incidents where U.S. Soldiers abused detainees, which the investigation characterized as "systemic." As used in the Taguba Investigation, the term "systemic" deals with a subset of the security and interrogation operations at only one interment /resettlement facility and is not theater-wide. However, MG Taguba testified before the Senate Armed Services Committee on 11 May 04, narrowing the extent of the term "systemic" by stating that these particular abuses were individual actions not committed at the direction of the chain of command and that the resulting photos were taken with personal cameras. Additionally, the Taguba Investigation recommended detention facilities make several changes that would help ensure compliance with the Geneva Conventions. As stated above, the DAIG uses the term "systemic" specifically to describe a problem if it is widespread and presents a pattern. As defined by the DAIG in this report, a systemic issue may be found either horizontally across many various types of units, or vertically through many command levels from squad through division or higher level. Based on our review and analysis of reports and case summaries of investigations and our observations and interviews conducted throughout this inspection, we could not identify a systemic cause for the abuse incidents.

(4) Recommendation: CJTF-7 and CJTF-180 continue to emphasize compliance with the requirements regarding the humane treatment of detainees.

Recommendation: Commanders continue to stress the importance of humane treatment of detainees and continue to supervise and train Soldiers on their responsibility to treat detainees humanely and their responsibility to report abuse.

b. Finding 2:

(1) Finding: In the cases the DAIG reviewed, all detainee abuse occurred when one or more individuals failed to adhere to basic standards of discipline, training, or Army Values; in some cases abuse was accompanied by leadership failure at the tactical level.

(2) Standard: See Appendix E.

(3) Inspection Results: As of 9 June 2004, there were 125 reported cases of detainee abuse (to include death, assault, or indecent assault) that either had been, or were, under investigation.

For the purpose of this inspection, we defined abuse as wrongful death, assault, sexual assault, or theft. As of 9 June 2004 we had reviewed 103 summaries of Criminal Investigation Division (CID) reports of investigation and 22 unit investigation summaries conducted by the chain of command involving detainee death or alleged abuse. These 125 reports are in various stages of completion. No abuse was determined to have occurred in 31 cases; 71 cases are closed; and 54 cases are open or undetermined. Of note, the CID investigates every occurrence of a detainee death regardless of circumstances.

Recognizing that the facts and circumstances as currently known in ongoing cases may not be all inclusive, and that additional facts and circumstances could change the categorization of a case, the Team placed each report in a category for the purposes of this inspection to understand the overall numbers and the facts currently known, and to examine for a trend or systemic issue. This evaluation of alleged abuse reports is not intended to, nor should it, influence commanders in the independent exercise of their responsibilities under the Uniform Code of Military Justice (UCMJ) or other administrative disciplinary actions. As an Inspector General inspection, this report does not focus on individual conduct, but on systems and policies.

We separated these 125 cases into two categories:

- (1) no abuse occurred
- (2) confirmed or possible abuse

In the first category of no abuse occurring, we further separate the reports into deaths (to include death from natural causes and justified homicide as determined by courts martial) and other instances (to include cases where there was insufficient evidence to determine whether abuse occurred or where the leadership determined, through courts martial or investigation, that no abuse occurred). There were a total of 19 natural deaths and justified homicides, and 12 instances of insufficient evidence or determined that no abuse occurred. Deaths occurred at the following locations: 15 at I/R facilities; 1 at Central Collecting Points (CPs); 1 at Forward CPs; and 2 at the point of capture (POC) for a total of 19. Other instances where it was determined that no abuse occurred were at the following locations: 2 at I/R facilities; 1 at Central CPs; 2 at Forward CPs; 5 at the POC; and 2 at locations which could not be determined or did not fall into doctrinal categories, for a total of 12.

In the second category of confirmed or possible abuse, we further separated the reports into wrongful deaths, deaths with undetermined causes, and other alleged abuse (e.g., assault, sexual assault, or theft). There were a total of 20 deaths and 74 incidents of other alleged abuse. Deaths occurred at the following locations: 10 at I/R facilities; 0 at Central CPs; 5 at

Forward CPs; and 5 at the POC, for a total of 20. Other instances of alleged abuse occurred at the following locations: 11 at I/R facilities; 3 at Central CPs; 11 at Forward CPs; 40 at the POC; and 9 at locations which could not be determined or did not fall into doctrinal categories, for a total of 74.

This review indicates that as of 9 June 2004, 48% (45 of 94) of the alleged incidents of abuse occurred at the point of capture. For this inspection, the DAIG Team interpreted point of capture events as detainee operations occurring at battalion level and below, before detainees are evacuated to doctrinal division forward or central collecting points (CPs). This allowed the DAIG Team to analyze and make a determination to where and what level of possible abuse occurred. The point of capture is the location where most contact with detainees occurs under the most uncertain, dangerous and frequently violent circumstances. During the period of April-August 2003 when units were most heavily engaged in combat operations, 56% (29 of 52) of point of capture incidents were reported. Even during this period of high intensity combat operations, Soldiers and leaders identified incidents that they believe to be abuse and the command took action when reported. Most of the allegations of abuse that occurred at the point of capture were the result of actions by a Soldier or Soldiers who failed to maintain their self discipline, integrity, and military bearing, when dealing with the recently captured detainees. There are a few incidents that clearly show criminal activity by an individual or individuals with disregard of their responsibility as a Soldier.

This review further indicates that as of 9 June 2004, 22% (21 of 94) of the alleged incidents of abuse occurred at I/R facilities. This includes the highly publicized incident at Abu Ghraib. Those alleged abuse situations at the I/R facilities are attributed to: individual failure to abide by known standards and/or individual failure compounded by a leadership failure to enforce known standards, provide proper supervision and stop potentially abusive situations from occurring.

While recognizing that any abuse incident is one too many, through a review of the summary reports of the 125 investigations and categorizing them, the DAIG did not identify a systemic cause for the abuse incidents. The DAIG uses the term "systemic" specifically to describe a problem if it is widespread and presents a pattern. As defined by the DAIG in this report, a systemic issue may be found either horizontally across many various types of units, or vertically through many command levels from squad through division or higher level. The DAIG determined that incidents where detainees were allegedly mistreated occurred as isolated events. In a few incidents, higher ranking individuals up to Lieutenant Colonel were involved; however, the chain of command took action when an allegation of detainee abuse was reported.

Recognizing that the facts and circumstances as currently known in ongoing cases may not be all inclusive, and that additional facts and circumstances could change the categorization of a case, the Team placed each report in a category for the purposes of this inspection to understand the overall numbers and the facts currently known, and to examine for a trend or systemic issue. This evaluation of alleged abuse reports is not intended to influence commanders in the independent exercise of their responsibilities under the Uniform Code of Military Justice (UCMJ) or other administrative disciplinary actions.

The DAIG Team that visited Iraq and Afghanistan found no incidents of abuse that had not already been reported through command channels; all incidents were already under investigation. The DAIG Team that visited units recently returning from Iraq did receive a total of 5 new allegations of potential abuse that occurred prior to January 2004. In each of these cases, CID and the chain of command were notified of the allegations. There is no evidence of

any cover-up of current detainee abuse by U.S. Soldiers. This is consistent with the results of the teams' sensing sessions that all currently deployed Soldiers were aware of their responsibility to report abuse and appeared to be willing and able to report it.

In studying the actual abuse investigations, the incidents may be broken down into 2 broad categories. The first category will be referred to as isolated abuse, and the second as progressive abuse. The first are those incidents that appear to be a one-time occurrence. In other words, these are incidents where individual Soldiers took inappropriate actions upon the capture of detainees or while holding or interrogating them. The second category of detainee abuse, referred to as progressive abuse because these usually develop from an isolated incident into a more progressive abuse.

There is substantial research on the behavior of guards in prisons and Enemy Prisoner of War (EPW)/Prisoner of War (POW) camps, in addition to the Department of Defense (DoD) experience of running simulated prisoner of war resistance training. Research indicates that regardless of how good the training and oversight, some inappropriate behavior will occur. (For example, one of the seminal studies of prisoner/guard behavior is Haney, C., Banks, C., & Zimbardo, P., *A Study of Prisoners and Guards in a Simulated Prison*, the Office of Naval Research, 1973. For a more recent review, along with significant commentary, see Philip Zimbardo, *A Situationist Perspective on the Psychology of Evil: Understand How Good People are Transformed into Perpetrators*, a chapter in Arthur Miller (Ed.) *The social psychology of good and evil: Understanding our capacity for kindness and cruelty*. New York: Guilford, 2004. Also worth reviewing are Stanley Milgram's studies, starting with *Obedience to authority*, New York: Harper & Row, 1974.) Because of this, the DoD simulated prisoner of war resistance training that prepares service members to resist exploitation, requires intensive oversight to prevent the abuse of Soldiers by other Soldiers.

Contributing factors to the first category of abuse include poor training (common in the cases the DAIG Team reviewed), poor individual discipline, novel situations (to include the stressors involved in combat operations), and a lack of control processes (specific oversight mechanisms). Commander's addressed the first category of abuse through counseling, administrative action, and UCMJ (up to and including courts-martial).

Below are 4 examples of this first category of detainee abuse from the 125 reported allegations referenced in the first paragraph of the inspection results above.

– One incident occurred at an internment/resettlement (I/R) facility where a Master Sergeant and her 3 subordinates attempted to beat several detainees as they arrived at the camp. Other Soldiers, not in her chain of command, prevented much of the potential abuse and then reported the Master Sergeant to the chain of command who took corrective action. All 4 Soldiers were administratively separated from the Army; 3 of these Soldiers also received nonjudicial punishment.

– In another incident a Specialist was threatening detainees by stating he would shoot them. A guard observed him making these threats and immediately turned the Specialist in to his chain of command. The commander took quick action, administering an Article 15, to prevent a recurrence.

– Another example occurred in an internment facility where a Specialist and a Staff Sergeant began to punish a detainee by using excessive force. Another Soldier from a different company joined them. The Platoon Sergeant discovered the incident and immediately relieved

both of the Soldiers in his platoon and pressed charges against all 3. All 3 received field-grade Article 15 punishments.

– Another illustrative incident occurred when an interrogator struck a detainee on the head during questioning. The International Committee of the Red Cross, via the mayor of the detainee's compound, discovered this after the fact. Once he was made aware of the incident, the Soldier's commander investigated and ultimately issued a field-grade Article 15. The commander then required 2 Soldiers to be present during every interrogation.

In these examples, abuse was discovered immediately by the command, and corrective actions were taken to prevent a recurrence. One comment made by a Noncommissioned officer (NCO) from a unit that did not have any abuse cases was that multiple levels of NCO oversight ensured compliance with the Rules of Engagement (ROE), and the team leaders and Platoon Sergeant maintained strict standards for all Military Police (MP). One interrogator NCO stated that in his unit there would be a number of people in the room during interrogations to ensure that Soldiers did not violate the Interrogation ROE.

The psychological research on abuse (see above) suggests that in similar situations, such as prisons, when some relatively minor abusive behavior occurs and corrective action is not taken, there is an escalation of violence. If there is uncorrected abuse and more people become involved, there is a diffusion of responsibility making it easier for individuals to commit abuse. The research further suggests that a moral disengagement occurs which allows individuals to rationalize and justify their behavior. (See Bandura, A., [Moral Disengagement in the Perpetration of Inhumanities](#), *Personality and Social Psychology Review*, 1999.)

In at least 11 of the 125 incidents reviewed by the DAIG Team, immediate corrective action was not taken by the chain of command. The reasons for this leadership failure included either a lack of fundamental unit discipline, ambiguous command and control over the facility or individuals involved, ambiguous guidance from command on the treatment of detainees, no control processes in place to provide oversight and notify the command of the incident, or, in very few cases, leader complicity at the Lieutenant Colonel level and below in the actions. This led to the second category of detainee abuse, referred to as progressive abuse because these usually develop from an isolated incident into a more progressive abuse.

Here are 5 examples of this second category from the 125 reported allegations referenced in the first paragraph of the inspection results above, where actions were not taken until more generalized abuse had occurred.

– The incidents involving Tier 1A at Abu Ghraib began no later than October and continued until December 2003. The degradation of the detainees by the guard force appears to have started out with smaller, less-intensive types of abuse and humiliation, and increased to physical assault and injury. There were no formal control processes, such as a routine inspection of Tier 1A during the night hours or electronic monitoring, in place to easily identify abuse and bring it to the attention of the command. Eventually, a Soldier who knew it was wrong was made aware of the abuse and reported it to CID. Charges were preferred on 20 March 2004 against 6 reserve MP Soldiers for detainee abuse, and further investigation continues.

– In a different incident that resulted in a death, 2 Warrant Officers appeared to exhibit a pattern of abusive interrogations. A detainee, who was overweight and in poor physical health, died during an interrogation. The CID investigation contained sworn statements indicating that

physical beatings at this site were common during this time and alleged that the two Warrant Officers routinely slapped and beat the detainees they were questioning. There were no control processes in place to review the interrogation techniques used in this facility. There was apparently no oversight on the behavior of the interrogators, and, although many of the guard personnel were aware of the techniques being used, the abusive behavior was not reported. There was a perception among the guard personnel that this type of behavior by the interrogators was condoned by their chain of command. Both Warrant Officers received a General Officer Memorandum of Reprimand and further disposition of the case is under review.

– In another incident a platoon detained 2 individuals, later released them on a bridge, and made them jump into a river below. One of the detainees drowned. Sworn statements indicated the platoon "as a whole" had previously discussed having detainees jump off the bridge, and the planned action apparently had the support of the Platoon Sergeant. There is no evidence to support any previous incidents by this platoon, but these discussions are indicators that junior leader deficiencies at the platoon level contributed to the death of a detainee. CID continues to investigate this incident.

– There was an incident involving a Sergeant First Class (SFC) telling his subordinates to, "rough them up," referring to 2 detainees in custody. This occurred in the middle of the night without any oversight and at a division collecting point operated by an infantry unit. There are indications that this SFC had given similar guidance earlier. Several of the SFC's subordinates actually performed most of the subsequent beating. There is no evidence that the SFC had abused detainees previously. This incident was adjudicated by both Special and Summary Courts-Martial, with the SFC receiving a reduction to Staff Sergeant (SSG) and a punitive censure. One SSG was reduced to a Specialist and received 30 days confinement; another SSG pled guilty to one specification of violation of a lawful general order and was reduced to the grade of Sergeant. Finally, a Specialist was found guilty at a summary court-martial and his punishment included forfeiture of \$1092 and hard labor without confinement for 45 days.

– One final example is an incident where a Soldier had been talking extensively with others in his unit about wanting to kill an Iraqi. This Soldier later shot and killed an Iraqi detainee who was flexi-cuffed and may have tripped while walking away from the Soldier. This incident is currently under investigation.

Although elimination of all abuse is the goal of the DoD Law of War Training several factors prevent the complete elimination of detainee abuse. These include:

a. The psychological process that increases the likelihood of abusive behavior when one person has complete control over another is a major factor. This is the same process that occurs in prisons, in EPW/POW camps, and in DoD resistance training. Even in well-trained and screened populations, it is a constant threat. This threat can be minimized through individual and unit training on proper procedures and standards of behavior and by leader supervision of actual operations.

b. Poor training in the handling of detainees increases the risk of abuse. Although most personnel interviewed had some training in the Law of Land Warfare, many did not have training specific to detainee handling. It was often the case that individuals conducting interrogations were not school-trained as interrogators.

c. Ambiguous instructions concerning the handling of detainees also greatly increase the risk of abuse. Some Soldiers believed their command encouraged behavior at the harsher end

of the acceptable range of behavior in the treatment of detainees. This can very quickly lead to abusive behavior, even if it is not the intent of the command. The Taguba Investigation makes clear that the 800th MP (I/R) Brigade leadership did not properly communicate to its Soldiers the requirements for the treatment of detainees. In order to mitigate the risk of abuse, commanders must give clear, unambiguous guidance, make sure that Soldiers understand the guidance, supervise Soldiers' operations, and then hold their Soldier's accountable for meeting standards.

d. Criminal behavior among a small percentage of Soldiers.

e. Combat operations, as a new experience for many Soldiers, combined with the above, may lead to Soldiers justifying abusive behavior as a result of their exposure to danger. This leads to a moral disengagement where Soldiers do not take responsibility for their actions.

f. Poor unit discipline, which is a function of poor leader supervision, allows abusive behavior an opportunity to occur. Again, the Taguba Investigation identified a serious lack of discipline among the units involved in detainee abuse.

The last 3 of these factors can be best prevented by making sure Soldiers understand the standards of behavior expected of them, and by leaders who maintain unit and individual discipline and exercise appropriate supervision of Soldiers.

Almost all of the abuse cases studied by the DAIG Team were isolated events. The Soldiers' chain of command, when notified of the allegation of abuse, took appropriate action and prevented further abusive behavior. The DAIG Team found that most abuse incidents were isolated events that, when discovered, were immediately corrected by commanders at battalion level and lower.

Those cases where corrective action did not occur, usually because the chain of command was not aware of the abuse, resulted in a continuation of abuse or a progression from talking about abuse to actually committing abuse. Factors that influenced this progression of abuse and responsive actions taken by units to mitigate these factors were:

a. Poor oversight and poor control mechanisms to inspect and check on Soldiers' behavior decreased the likelihood that abuse would be discovered by command. This led to a breakdown in the command and control of Soldiers interacting with detainees. One NCOIC stated that the chain of command did not visit his location very often, and that when they began to receive enemy fire, he did not see the Commander or Command Sergeant Major (CSM). In response, over time, several units developed standing operating procedures that incorporated specific control mechanisms, such as requiring a certain number of personnel to be present during interrogations, having all Soldiers sign a document outlining acceptable behavior, and tasking independent officers to monitor all detainee operations, with the ability to observe anything, anytime, within their facility.

b. A command climate that encourages behavior at the harsher end of the acceptable range of behavior towards detainees may unintentionally, increase the likelihood of abuse. One officer interviewed stated that there is often a "do what it takes" mindset. This appeared to be more prevalent in the early days of the war in Iraq. Among other responses, the CJTF-7 Rules for Detainee Operations, published 30 November 2003, states, "Treat all persons with dignity and respect." In addition, on 12 October 2003, CJTF-7 published a memorandum stating all interrogations would be, "applied in a humane and lawful manner with sufficient oversight by

trained investigators or interrogators. Interrogators and supervisory personnel will ensure uniform, careful, and safe conduct of interrogations."

c. In the few cases involving the progression to more serious abuse by Soldiers, tolerance of inappropriate behavior by any level of the chain of command, even if minor, led to an increase in the frequency and intensity of abuse. In a few cases, the perception, accurate or not, that Other Governmental Agencies(OGA) conducted interrogations using harsher methods than allowed by Army Regulation, led to a belief that higher levels of command condoned such methods. As noted in paragraph b above, CJTF-7 began to publish specific guidance that emphasized the humane treatment of detainees. At the time of the DAIG Team's visit to the theater, leaders and Soldiers uniformly understood the need to treat detainees humanely.

It is evident there were Soldiers who knew the right thing to do and reported abuse when they discovered it. Soldiers who believed that abusive behavior was not acceptable reported almost all of the abuse incidents. Some of these Soldiers stopped other Soldiers from hurting detainees, demonstrating moral courage in the face of peer pressure. Others reported serious abuse when it involved their comrades and leaders. This finding on abuse focused on a very small percentage of Soldiers who may have committed abusive behavior, and not on the vast majority that, even under the stress of combat and poor living conditions, and presented with sometimes resistant and hostile detainees, have treated all within their care humanely.

(4) Root Cause: Detainee abuse was an individual failure to uphold Army Values and in some cases involved a breakdown in the leadership supervision of Soldiers' behavior.

(5) Recommendation: Commanders enforce the basic fundamental discipline standards of Soldiers, provide training, and immediately correct inappropriate behavior of Soldiers towards detainees to ensure the proper treatment of detainees.

Recommendation: Commanders assess the quality of leadership in units and replace those leaders who do not enforce discipline and hold Soldiers accountable.

Recommendation: TRADOC develop and implement a train-the-trainer package that strongly emphasizes leaders' responsibilities to have adequate supervision and control processes in place to ensure the proper treatment of detainees.

Recommendation: TRADOC integrate training into all Professional Military Education that strongly emphasizes leaders' responsibilities to have adequate supervision and control processes in place to ensure the proper treatment of detainees.

Recommendation: The G3 require pre-deployment training include a strong emphasis on leaders' responsibilities to have adequate supervision and control processes in place to ensure proper treatment of, and prevent abuse of, detainees.

c. Finding 3:

(1) Finding: Of all facilities inspected, only Abu Ghraib was determined to be undesirable for housing detainees because it is located near an urban population and is under frequent hostile fire, placing Soldiers and detainees at risk.

(2) Standard: See Appendix E.

(3) Inspection Results: Abu Ghraib was overcrowded, located near a densely populated urban area and on a dangerous main supply route, and subject to frequent hostile enemy fire from enemy mortars or rockets. The facility was located approximately 20 miles west of Baghdad. The entire encampment of Abu Ghraib was quite large, covering 280 acres. This facility has had up to 10,000 persons interned there and was considered the most notorious landmark in all of Iraq, made so by the previous regime under Saddam Hussein.

Abu Ghraib consisted of three distinct separate facilities: the hard site prison complex, Camp Vigilant, and Camp Ganci. Except for Tier 1, the rest of the hard site prison complex (Tiers 2 through 7) was under complete control of Iraqi prison guards under supervision of the Coalition Provisional Authority. Criminals were housed there who had committed crimes against other Iraqis. Camp Vigilant was under complete U.S. Armed Forces control. It was the least populated facility of the three at Abu Ghraib, housing several hundred detainees.

The facility employs over 1500 Soldiers and civilians and there is no Post Exchange (PX) within the walls of Abu Ghraib. This was one of the major complaints from Soldiers. Routine trips for PX runs did not occur because of the danger in traveling to Camp Victory on the main supply route. Soldiers complained that they could not get necessary clothing and uniform items when needed.

On 19 March 2004, the official detainee headcount in Camps Ganci and Vigilant was 5967 detainees under U.S. control. This number frequently fluctuated because of releases, transfers, or additional captures of detainees. Including the hard site, there were 7490 detainees on this date. Only one interment/resettlement (I/R) Military Police battalion was charged with managing, operating, and maintaining security of Camps Ganci and Vigilant. By doctrine an I/R battalion should support the following ratios: up to 4,000 EPWs/CIs; 8,000 dislocated civilians; or 1,500 U.S. Armed Forces prisoners. The Taguba Investigation also addressed the problems of under-manning at Abu Ghraib.

Abu Ghraib also did not have sufficient protection measures in place to protect the detainees from hostile fire. Abu Ghraib was frequently under mortar and small arms fire. Detainees suffered casualties in the past due to enemy hostile fire. Detainees at Camps Vigilant and Ganci did not have access to protective bunkers or shelters, placing them at great risk.

Camp Ganci was overcrowded with a population of over 5000 detainees at the time of the DAIG inspection. Camp Ganci was designed and built as an Enemy Prisoner of War (EPW) camp, and the camp living environment was not conducive to a criminal or high security population. The population of the camp alone made security and control inherently difficult and dangerous. There were 8 compounds in Camp Ganci, and the capacity for each compound was 500. During the inspection, the average population was from 600 to 700 detainees per compound.

Camp Ganci's 8 compounds inside of Abu Ghraib had similar problems with the guard towers and perimeter triple-standard concertina wire that the old compounds at Camp Bucca suffered. The overcrowding and cramped conditions at Camp Ganci, and the fact that the distance between each compound was only 30 to 40 feet, compounded the safety and security concerns for Soldiers. Detainee rioting had occurred in the past. Lighting at Camp Ganci was poor, especially at compound 6, according to interviewed Soldiers. The physical design of the camps within the facility was not optimal for the mission. The towers, for example, provided limited visibility due to numerous blind spots. Towers supporting Camp Ganci were not placed

reasonably well, as they should have been, with good fields of fire. Some towers faced each other, and there were some identified blind spots throughout the compounds according to interviewed Soldiers. Entrance and egress to the compounds were hampered by cumbersome, makeshift gates made of concertina wire and wood that dragged across the ground. This made rapid access very difficult. Sally ports were used primarily as gates or "slow down" barriers.

The Single Channel Ground/Air Radio System (SINCGARS) system used at Abu Ghraib, when operable, was maintained inside the compound for communication with units outside the compound and the roving patrols. Because many units were using the same frequency, crossed radio traffic was common between roving patrols, other outside units, and the Tactical Operations Center (TOC) inside the compound. The facility NCOIC at Abu Ghraib stated there was also a shortfall in radios, which hampered communications and security within the compound. In some instances, the guards in the towers had communication with the TOC, but not with the roving guards on the ground. So, in order to communicate with a tower, the roving guards would have to yell up to them. The guards would also have to yell up to the towers when they wanted to pass information to the TOC. Due to the ineffective communication systems at Abu Ghraib and Camp Bucca, Soldiers took it upon themselves to purchase handheld commercial radios to communicate within the camps. Because these radios are unsecured, they pose a communications security (COMSEC) problem; frequencies can be easily monitored by outside forces using the same commercially available radios. The commercial radios were also unable to communicate with the military issue radios.

During sensing sessions, NCOs at Abu Ghraib stated there were no standardized procedures for searching Iraqis entering the compound. The DAIG Team's findings are consistent with the Ryder Report that stated, "The lack of policy and standard operating procedures results in inconsistent application of basic security protocols. Visitation is a serious opportunity to introduce security and safety hazards."

Refuse and litter were seen within one of the Ganci compounds. It could not be determined if the trash was actually refuse that had migrated to the surface from an old landfill site on which Camp Ganci was built. There was approximately one portable latrine per 25 detainees, and there was a contract in place to clean the latrines. There was, however, a bad smell throughout the area from sewage because disinfectant chemicals were not replaced in the latrines. According to sensing sessions, there were only 12 showerheads in each Ganci compound for 600 to 700 detainees. The detainees showered every other day, but the guards ran all 600 to 700 detainees through the process in 2 hours. The lack of laundry capabilities or services for the detainees was similar to the situation at Camp Bucca. Detainees had tubs and soap, but there was no accountability on where the tubs were and how many there were. The unit submitted a contract request to start a laundry service for detainees.

The supply of fresh water was difficult to maintain at the required levels for drinking and personal hygiene for both Soldiers and detainees. According to interviews, Abu Ghraib received fresh water from a Baghdad city water main that frequently broke down. A 3-day supply (200K gallons) was required to be on-hand. The day before the DAIG Team arrived, the reserve water supply was down to 50K gallons. Rationing of fresh water was not uncommon for Soldiers and detainees according to leaders and Soldiers from interviews and sensing sessions.

Food quality for detainees was a serious issue at Abu Ghraib. Spoiled and contaminated food (rodent droppings and dirt) had been delivered by the contractor for the detainees in the past. Units at Abu Ghraib had to use unit stocks of Meals, Ready to Eat

(MREs) to distribute to detainees instead. The unit was working with the contracting officer to remedy the substandard work of the contractor.

Other problems observed included problems with the existing power generators and lack of ventilation for the detainees.

There were planned and ongoing projects at Abu Ghraib. The new Entry Control Point (ECP) was recently completed. This will allow 200 visitations of detainee family members a day and will provide a stand-off of 100 meters for force protection. The project included a new parking lot. Another ongoing project was the new reception center. Besides the ECP and reception center, other projects planned include: perimeter fencing around Abu Ghraib; completion of Camp Avalanche (recently renamed Camp Redemption), a new facility with a capacity of 3000 detainees; and future plans to upgrade Camps Ganci and Vigilant. Both the Taguba Investigation and Ryder Report mentioned the need for structural improvements and renovations at various facilities. The Taguba Investigation stated the need for structural improvements, including enhancements of perimeter lighting, additional chain link fencing, staking down of all concertina wire, hard site development, and expansion of Abu Ghraib. One recommendation of the Ryder Report included renovation of all available cells at Abu Ghraib to facilitate consolidation and separation of the different categories of detainees. The Ryder Report also recommended modification of the Abu Ghraib master plan that allowed expansion and increased detainee capacity by means of renovation. All of the improvements mentioned in the Taguba Investigation and Ryder Report are needed at Abu Ghraib if U.S. Forces continue to use it as an I/R facility. However, because of its location in a densely populated urban area and the frequent hostile fire, the DAIG Team found that the facility should be phased out as an I/R facility, with Camp Bucca becoming the primary I/R facility in Iraq.

Abu Ghraib will be the central facility for the Iraqi Prison System after transition to the interim government. However, Abu Ghraib's location near an urban and hostile environment goes against doctrine for setting up I/R facilities. The area lends itself to poor and dangerous living and working conditions. In contrast, Camp Bucca in southern Iraq is isolated from local Iraqi populations, not frequently attacked, and is close to vital supply lines and logistical support (Navistar in Kuwait). Camp Bucca has room to expand if necessary and is already used as an overflow facility for Abu Ghraib. At the time of the DAIG visit, the detainee population of Camp Bucca was just over 1700. The new compounds at Camp Bucca (1 through 6) have a capacity for 4500 detainees. If the old compounds (7 through 11) are renovated in the same manner as the new compounds, Camp Bucca could reasonably expand the population capacity by several thousand if needed. Once the Camp Bucca expansion is completed and the "Iraqi on Iraqi" criminal population at Camp Ganci are segregated from other detainees, a phase out of Abu Ghraib as an I/R facility and complete turnover to the interim Iraqi government can take place.

(4) Root Cause: Units operating the Abu Ghraib facility were overwhelmed by the frequent hostile fire, the overcrowded conditions, and the deteriorating infrastructure.

(5) Recommendation: CJTF-7 expand Camp Bucca as an internment/resettlement facility in order to transfer detainees from Camps Ganci and Vigilant, and phase out U.S. Armed Forces detainee operations at Abu Ghraib completely.

[Next page intentionally left blank]

Chapter 4

Interrogation Operations

1. **Summary of Findings:** Commanders recognized the need for timely, tactical human intelligence and adapted to the environment by keeping detainees longer at the point of capture and collecting points to gain and exploit intelligence. Commanders and interrogators conducted tactical questioning to gain immediate battlefield intelligence. Holding detainees longer than 72 hours increased requirements for facility infrastructure, medical care, preventive medicine, trained personnel, logistics, and security.

Doctrine does not clearly and distinctly address the relationship between the Military Police (MP) operating I/R facilities and the Military Intelligence (MI) personnel conducting intelligence exploitation at those facilities. Neither MP nor MI doctrine specifically defines the distinct but interdependent roles and responsibilities of the two in detainee operations. MP doctrine states MI may collocate with MP at detention sites to conduct interrogations, and coordination should be made to establish operating procedures. MP doctrine does not, however, address approved and prohibited MI procedures in an MP-operated facility. It also does not clearly establish the role of MPs in the interrogation process. Conversely, MI doctrine does not clearly explain MP internment procedures or the role of MI personnel within an internment setting.

There is no DoD or Army policy that addresses the establishment and operation of interrogation facilities, including Joint Interrogation Facilities (JIFs) and Joint Interrogation and Debriefing Centers (JIDCs). Doctrine provided in two field manuals (FMs) dealing with military intelligence, FM 34-52 and FM 3-31, Joint Force Land Component Commander Handbook (JFLCC), 13 December 2001, contains inconsistent guidance on terminology, structure, and function of these facilities.

Shortfalls in numbers of interrogators and interpreters, and the distribution of these assets within the battlespace, hampered human intelligence (HUMINT) collection efforts. Valuable intelligence—timely, complete, clear, and accurate—may have been lost as a result. Interrogators were not available in sufficient numbers to efficiently conduct screening and interrogations of the large numbers of detainees at collecting points (CPs) and internment/resettlement (I/R) facilities, nor were there enough to man sufficient numbers of Tactical Human Intelligence Teams (THTs) for intelligence exploitation at points of capture. Interpreters, especially those Category II personnel authorized to participate in interrogations, were also in short supply.

Interviewed MI leaders and Soldiers indicated that G2s and S2s were conducting interrogations of detainees without the proper training on the management of HUMINT analysis and collection techniques. They were not adequately trained to manage the full spectrum of HUMINT assets being used in the current operating environment. The need for these officers to understand the management of HUMINT operations is critical to successful HUMINT exploitation in the current operating environment.

Army doctrine found in Field Manual (FM) 34-52, Intelligence Interrogation, 28 September 1992, lists 17 accepted interrogations approach techniques. It states that those approach techniques are not inclusive of all possible or accepted techniques. The DAIG Team reviewed interrogation approach techniques policy for both OEF and OIF and determined that

CJTF-180 and CJTF-7 included additional interrogation approach techniques not found FM 34-52. The DAIG Team found that officially approved CJTF-7 and CJTF-180 policies and the early CJTF-180 practices generally met legal obligations under Geneva Convention Relevant to Prisoners of War (GPW), the Geneva Convention Relative to the Protection of Civilian Persons in Time of War (GC), the UN Convention Against Torture and Other Cruel, Inhuman or Degrading Treatment or Punishment (CAT), the U.S. Torture statute, 18 USC §§2034, 2034A, if executed carefully, by trained soldiers, under the full range of safeguards. The DAIG Team found that some interrogators may not have received formal instruction from the U.S. Army Military Intelligence Center on interrogation approach techniques not contained in FM 34-52. Additionally, the DAIG Team found that while commands published interrogation approach policy, some subordinate units were unaware of the current version of those policies. Content of unit interrogator training programs varied among units in both OEF and OIF. However, no confirmed instance involving the application of approved approach techniques resulted in an instance of detainee abuse.

2. Findings:

a. Finding 4:

(1) Finding: Tactical commanders and leaders adapted to the environment and held detainees longer than doctrinally recommended due to the demand for timely, tactical intelligence.

(2) Standard: See Appendix E.

(3) Inspection Results: In OPERATION ENDURING FREEDOM (OEF) and OPERATION IRAQI FREEDOM (OIF), company through division units held detainees longer than the doctrinal timeframes. By doctrine, companies and battalions are to evacuate detainees as quickly as possible to a division forward collecting point (CP). Interviewed point of capture battalion and company leaders stated 61% (25 of 41) of their units established CPs and held detainees at their locations from 12 hours up to 30 days. Of the geographically remote inspected companies and battalions, 3 of 3, established CPs at their locations. By doctrine, division forward CPs are located at maneuver brigades and can hold detainees for up to 12 hours before evacuating to division central CPs.

All interviewed leaders from 11 division forward CPs stated their facilities held detainees from 24 hours up to 54 days. By doctrine, division central CPs are located near the division support area (DSA) and can hold detainees for up to 24 hours before evacuating to the corps holding area (CHA) or internment/resettlement (I/R) facility. All interviewed leaders from 4 central CPs stated their facilities held detainees from 72 hours up to 45 days.

The primary reason units held detainees at these locations was to conduct screenings and interrogations closer to the point of capture. The result of holding detainees for longer timeframes at all locations was increased requirements in facility infrastructure, medical care, preventive medicine, trained personnel, logistics, and security. Organic unit personnel at these locations did not have the required institutional training and were therefore unaware of, or unable, to comply with Army policies in areas such as detainee processing, confinement operations, security, preventive medicine, and interrogation.

Current detainee doctrine is written to apply to a linear battlefield with an identifiable combat zone and rear area, and with the presumption that detainees at the point of capture will

normally be enemy prisoners of war (EPWs). EPWs are to be humanely evacuated from the combat zone to internment facilities (normally located in the corps communication zone (COMMZ)). Evacuation is accomplished as quickly as possible for the safety of the EPWs and to ensure operations of the maneuver unit are not hampered. Doctrine assumes EPWs are normally captured forward in the combat zone by company and battalion-sized units. While doctrine does provide for interrogations to be conducted at forward locations, it limits the time detainees should be held at these sites.

By doctrine, EPWs are evacuated from companies and battalions to a division forward CP located in the brigade area of operations. A forward CP is normally a guarded, roped-off area (concertina or razor tape) or a secure fixed facility, with potable water, a latrine, and a trench or cover for protection from indirect fire. A division MP company commander plans for a platoon to operate the forward CP and process EPWs using the STRESS method (search, tag, report, evacuate, segregate, and safeguard). The MP company medical section provides medical support. Additional medical support can be requested by the brigade medical officer from the forward support battalion (FSB). EPWs doctrinally do not remain at a forward CP for more than 12 hours before being escorted to the division central CP.

By doctrine, the division central CP is established near the division support area (DSA). The central CP is larger than the forward CP, contains some type of tentage or uses an existing shelter/structure to protect detainees from the elements. The central CP may have multiple water and latrine sites. A division MP company operates the CP and continues to process EPWs using the STRESS method. The MP company medical section provides medical support. Units within the DSA provide support as stated in the division operations order. EPWs do not remain at a central CP for more than 24 hours before being escorted to the CHA.

By doctrine, a CHA is usually located near a base or base cluster in the corps rear area with one CHA to support each division conducting operations. Normal hold time at the CHA is 72 hours, but the CHA must be prepared to hold EPWs for extended periods until they are evacuated to an internment facility or until hostilities end. A CHA is a semi-permanent facility. The capture rate and captive categories determine the size of the CHA, and it should be divided into two or more compounds for segregation, security, and ease of control. The CHA has areas designated for EPW reception, processing, storage and accountability of detainee property, interrogation, medical facilities, showers, and protection from direct and indirect fire. A corps MP platoon or corps MP company operates a CHA and may be augmented with additional MPs. Support agreements can be arranged between MP headquarters and a base or base cluster where the CHA is located. Class I through Class IX supplies are requested through logistics channels and Class VIII through medical channels.

Doctrine does not address the unique characteristics of OIF and OEF, specifically operations in non-linear battlespaces and large numbers of detainees whose status is not readily identifiable as combatants, criminals, or innocents. In OIF and OEF, units held detainees at division CPs longer than doctrinal timeframes and established CPs at companies and battalions. Commanders held detainees at forward locations to facilitate more effective initial screenings (to determine detainees' status and disposition) and to obtain more timely intelligence than would be obtained from interrogations at I/R facilities. Interviews and sensing sessions with leaders and Soldiers indicated a common perception at the unit level that once a detainee was evacuated, interrogations conducted at higher echelon facilities did not return tactical intelligence to the capturing unit. Furthermore, commanders and MI personnel perceived additional value in holding detainees at CPs where they can be segregated and intelligence is less likely to be compromised. Detainees held at CPs were also available for

follow-up interrogations and clarifications of details based on the tactical exploitation of intelligence previously provided. Finally, interrogators at CPs are familiar with the unique local characteristics that enable more effective intelligence exploitation, i.e., religious affiliation, tribal affiliation, and regional politics.

Doctrine does not address how to effectively screen and interrogate large numbers of captured persons of undetermined status. Unlike EPWs, detained persons in OIF and OEF did not have a clear status upon capture. Capturing units were attempting to screen persons close to the point of capture to confer status in a timely manner. By doing so, they could quickly release innocent persons with no intelligence value who would otherwise burden the detention system, or detain combatants or persons of potential intelligence value for continued exploitation. In situations where effective screening couldn't be accomplished at the point of capture, companies and battalions established collecting points and held detainees instead of evacuating them to higher echelons. The time detainees were held at company and battalion locations varied from 12 hours up to 30 days based on the number of detainees and the availability of interrogators.

A result of holding detainees at CPs was company, battalion, brigade and divisional units were being required to meet the standards of CHAs without the organic resources (trained personnel, materials, equipment, and facilities) to do so. The DAIG Team found most personnel, especially at battalion and brigade CPs, did not have the training to perform the humanitarian, security, and administrative requirements for extended holding times. Because most personnel were not trained in detention operations they were unaware of Army doctrinal requirements, policies, and procedures that address the specific responsibilities for confinement, security, preventive medicine, and interrogation. The DAIG Team found most CP operations were conducted using standing operating procedures (SOPs) developed by previous units; internal tactics, techniques, and procedures; common sense; and basic soldier skills and knowledge.

Holding detainees for longer periods of time at CPs increases the infrastructure requirements from those needed for mobile, temporary holding areas to the more substantial demands of semi-permanent facilities. CPs have to provide increased internal and external security to physically contain the detainees. Considerations have to be made for areas designated for detainee reception, processing, storage and accountability of detainee property, interrogation, medical care, latrines, and protection from direct and indirect fire. The medical requirements for the care of detainees increase (e.g., trained personnel, supplies, and equipment), as do the requirements for preventive medicine (e.g., showers, sundry packs, pest control, and facility inspections). Units have increased requirements for logistics (e.g., Class I, Class II (shotguns, restraints, communications, and uniforms), Class III, Class V (non-lethal ammunition), and security (e.g., permanent external guard force and quick reaction force).

Detainee doctrine does not address operations in a non-linear battlespace. Doctrine was written for operations on a linear battlefield on which EPWs were to be quickly evacuated to corps holding areas or I/R facilities. Commanders in OIF and OEF were holding detainees closer to the point of capture to expedite intelligence exploitation. The result of holding detainees forward of I/R facilities was that companies, battalions, brigades and divisions were being required to meet higher standards of detainee humanitarian care when these units are not organically resourced with the trained personnel, materials or equipment to operate semi-permanent facilities. The DAIG Team found that battalions, brigades or divisions operating CPs are not trained or resourced to run semi-permanent collection/holding facilities, and no units are fully compliant with Army policy. The DAIG Team also found that the inspected units were

treating detainees humanely and in accordance with the provisions of the Geneva Conventions. Units continue to physically improve the facilities of the CPs and obtain external support for personnel and resources.

Although the Ryder Report cited changes are required in doctrine and organizational structure related to detention and correction operations, it did not go into specific details. The report did note the wide variance of standards and approaches at collecting points and recommended assessing the tactical feasibility of decreasing the number of collection points.

(4) Root Cause: Units did not comply with doctrine that requires the quick evacuation of detainees to internment facilities. Units held detainees at CPs closer to the point of capture for longer periods of time to conduct more effective interrogation and intelligence exploitation.

(5) Recommendation: TRADOC revise doctrine to address the criteria for establishing and operating collecting points to enable commanders to more effectively conduct intelligence exploitation in a non-linear battlespace.

b. Finding 5:

(1) Finding: Doctrine does not clearly specify the interdependent, and yet independent, roles, missions, and responsibilities of Military Police and Military Intelligence units in the establishment and operation of interrogation facilities.

(2) Standard: See Appendix E.

(3) Inspection Results: Doctrine does not provide clear guidance on the relationship between Military Police (MP), responsible for the safekeeping of detainees, and Military Intelligence (MI), responsible for intelligence collection. Neither MP nor MI doctrine clearly defines the distinct but interdependent roles, missions, and responsibilities of the two in detainee operations. MP doctrine states MI may collocate with MP at detention sites to conduct interrogations, and coordination should be made to establish operating procedures. MP doctrine does not, however, address approved and prohibited MI procedures in an MP-operated facility. It also does not clearly establish the role of MPs in the interrogation process. Conversely, MI doctrine does not clearly explain MP internment procedures or the role of MI personnel in an internment setting. Subordination of the MP custody and control mission to the MI need for intelligence can create settings in which unsanctioned behavior, including detainee abuse, could occur. Failure of MP and MI personnel to understand each other's specific missions and duties could undermine the effectiveness of safeguards associated with interrogation techniques and procedures. Failure of MP and MI personnel to understand each other's specific missions and duties could undermine the effectiveness of safeguards associated with interrogation techniques and procedures.

MP doctrine explicitly outlines MP roles and responsibilities in operating collecting points (CPs), corps holding areas (CHAs) and internment/resettlement (I/R) facilities. MP doctrine identifies the priorities of detainee operations as the custody and control of detainees and the security of the facility. MP doctrine states detainees may be interrogated at CPs, CHAs and I/R facilities operated by MPs to facilitate the collection of intelligence information. It highlights the need for coordination between MP and MI to establish operating procedures. MPs are responsible for passively detecting and reporting significant information. MPs can assist MI screeners by identifying captives who may have information that supports Priority Intelligence Requirements (PIRs). MPs can acquire important information through observation and insight

even though they are not trained intelligence specialists. MP interaction with detainees is limited, however, to contact necessary for the management of a safe and secure living environment and for security escort functions during detainee movement. Thus, active participation by MPs in the intelligence exploitation process is not within the doctrinal scope of the MP mission.

MI doctrine clearly states MPs command and operate CPs and CHAs, but it does not address operational authority for I/R facilities. MI doctrine specifies MPs conduct detainee receipt, escort, transport, and administrative processing functions, including document handling and property disposition. MI doctrine in FM 34-52, contrary to MP doctrine in FM 3-19.1, contains a passage that implies an active role for MPs in the screening/interrogation process: "Screeners coordinate with MP holding area guards on their role in the screening process. The guards are told where the screening will take place, how EPWs and detainees are to be brought there from the holding area, and what types of behavior on their part will facilitate the screenings." The implication in FM 34-52 that MPs would have an active role in the screening process is in conflict with MP doctrine that states MPs maintain a passive role in both the screening and interrogation processes. This passage could cause confusion with MI personnel as to the role of MPs in screenings and interrogations. The Ryder Report addressed the issue of MPs maintaining a passive role in interrogations, stating that, "Military police, though adept at passive collection of intelligence within a facility, do not participate in Military Intelligence supervised interrogation sessions." The report further states that the active participation of MPs in interrogations could be a source of potential problems: "Such actions generally run counter to the smooth operation of a detention facility, attempting to maintain its population in a compliant and docile state." The Ryder Report recommends establishing "procedures that define the role of military police soldiers securing the compound, clearly separating the actions of the guards from those of the military intelligence personnel."

Additionally, two intelligence oriented field manuals, FM 34-52, Intelligence Interrogation (discussed above), and FM 3-31, Joint Force Land Component Commander Handbook (JFLCC), contain inconsistent guidance on terminology, structure, and function of interrogation facilities. Neither field manual address the relationship of MI and MP personnel within those facilities. FM 34-52 describes a Theater Interrogation Facility (TIF). FM 3-31 describes a Joint Interrogation Facility (JIF) and Joint Interrogation and Debriefing Center (JIDC). Interrogation facilities in OEF and OIF identified themselves as JIFs and JIDCs. Commanders and leaders structured the organization and command relationships within these JIFs and JIDCs to meet the unique requirements of their operating environments.

The DAIG Team determined MP and MI doctrine did not sufficiently address the interdependent roles of MP and MI personnel in detainee operations in OEF and OIF. Doctrine needs to be updated to clearly specify the roles and responsibilities of MPs in the intelligence exploitation of detainees. It should also clearly specify the roles and responsibilities of MI personnel within MP-operated internment facilities. For example, MP and MI doctrine should address and clarify: (1) command and control relationship of MP and MI personnel within internment facilities; (2) MPs' passive or active role in the collection of intelligence; (3) interrogation techniques and the maintenance of good order within the detention facility; (4) detainee transfer procedures between MP and MI to conduct interrogations, including specific information related to the safety and well-being of the detainee; and (5) locations for conducting interrogations within I/R or other facilities.

(4) Root Cause: Current doctrine does not adequately address or prepare MP or MI units for collaboratively conducting detainee operations and provides inconsistent guidance on terminology, structure, and function of interrogation facilities.

(5) Recommendation: TRADOC develop a single document for detainee operations that identifies the interdependent and independent roles of the Military Police custody mission and the Military Intelligence interrogation mission.

Recommendation: TRADOC establish doctrine to clearly define the organizational structures, command relationships, and roles and responsibilities of personnel operating interrogation facilities.

Recommendation: The Provost Marshal General revise, and the G2 establish, policy to clearly define the organizational structures, command relationships, and roles and responsibilities of personnel operating interrogation facilities.

Recommendation: The G3 direct the incorporation of integrated Military Police and Military Intelligence detainee operations into field training exercises, home station and mobilization site training, and combat training center rotations.

c. Finding 6:

(1) Finding: Military Intelligence units are not resourced with sufficient interrogators and interpreters, to conduct timely detainee screenings and interrogations in the current operating environment, resulting in a backlog of interrogations and the potential loss of intelligence.

(2) Standard: See Appendix E.

(3) Inspection Results: Shortfalls in numbers of interrogators (Military Occupational Specialty (MOS) 97E and 351E) and interpreters, and the distribution of these assets within the battlespace, hampered human intelligence (HUMINT) collection efforts. Valuable intelligence—timely, complete, clear, and accurate—may have been lost as a result. Interrogators were not available in sufficient numbers to efficiently conduct screening and interrogations of the large numbers of detainees at collecting points (CPs) and internment/resettlement (I/R) facilities, nor were there enough to man adequate numbers of Tactical Human Intelligence (HUMINT) Teams (THTs) for intelligence exploitation at points of capture. Interpreters, especially those Category II personnel authorized to participate in interrogations, were also in short supply. Interrogations were conducted at locations throughout the battlespace by trained military interrogators, contract interrogators, and, in some forward locations, by leaders and Soldiers with no training in military interrogation tactics, techniques, and procedures. Interrogations observed by DAIG Team members were conducted in accordance with Army policy and doctrine. Policy and doctrine clearly reinforce and fully comply with the provisions of the laws of land warfare, and all Army interrogators are trained extensively on approved and prohibited interrogation techniques.

The quantity and distribution of military interrogators were insufficient to conduct timely intelligence exploitation of non-compliant detainees in the current operational environment. 78% (18 of 23) of interviewed S2s and G2s stated the shortage of interrogators at points of capture and company and battalion CPs resulted in untrained combat leaders and Soldiers conducting screenings and field interrogations. 89% (17 of 19) of interviewed military interrogators cited a shortage of interrogators, resulting in backlogs of interrogations at I/R

facilities. Military interrogators at Abu Ghraib stated there were detainees that had been in custody for as long as 90 days before being interrogated for the first time.

In OEF and OIF, the total number of interrogators varied by unit and location. Each division (11D, 1AD, 41D, 1st CAV, 82nd ABN, and 101st ABN) deployed with an MI battalion that was resourced with interrogators. The 519th MI BN of the XVIII ABN Corps, and the 202nd MI BN, echelons above corps, deployed with interrogators. The 30th and 39th Army National Guard (ARNG) Separate Brigades were resourced with interrogators. All of the above units supplemented interrogators with counterintelligence Soldiers (MOS 97B and 351B) to increase interrogation capabilities. The 205th MI Brigade, V Corps; 504th MI Brigade, III Corps; and the 902nd MI Group had no interrogators and therefore conducted all interrogations using counterintelligence Soldiers. The number of interrogators in the above units varied from 4 in the ARNG Separate Brigades to 16 in some divisions, to approximately 60 in the 519th MI BN. Military interrogators in OIF were supplemented by 31 contract interrogators. (12 contract interrogators have re-deployed for personal reasons since the blanket purchase agreement (contract) was issued 14 August 2003). CJTF-180 was preparing to hire contract interrogators for OEF at the time of the inspection.

Because detainees have varying degrees of intelligence value, there is no doctrinal formula to determine the recommended ratio of interrogators and interpreters to detainees. All detainees require initial screening after capture to determine their status and potential intelligence value. The requirement for interrogation of each detainee is unique and based on potential intelligence yield, the characteristics of the detainee, and the information requirements of the unit. Some detainees may only require a single screening to determine their status and be released, while others will be screened, determined to be of intelligence value, and subsequently interrogated a few times, several times over many weeks, or numerous times over many months. The ratio of interrogators to detainees varied at each facility. At Abu Ghraib there were 120 interrogators for 1500 detainees determined to be of intelligence value; at Brassfield-Mora there were 2 interrogators for 50 such detainees; and at Bagram there were 12 interrogators for 192 detainees of intelligence value.

Category II Arabic, Pashtu, and Dari interpreters--interpreters with U.S. citizenship, but no security clearances-- were also identified as shortages throughout OEF and OIF. As crucial players in every aspect of operations, skilled interpreters were in high demand. The quality of intelligence derived from an interrogation can depend greatly on the ability of the interpreter to work effectively with the interrogator. An effective interpreter must not only convey the accurate meaning of language, he/she must be able to express the implied message in the demeanor of the interrogator. To function together as a successful team requires specific, individualized training prior to employment in the field, as well as time working together to maximize their effectiveness. Category II interpreters should be deployed in sufficient numbers to support the commander's intelligence gathering requirements.

Detainee operations in a non-linear battlespace presented a unique challenge, requiring screening operations to be placed closer to points of capture. Using properly trained HUMINT soldiers to screen detainees in the immediate vicinity of the point of capture reduces the number of innocents detained, produces more timely intelligence, and increases the quality of evidence collection and documentation for use in future judicial proceedings. One senior MI officer indicated that his division only had the manpower to utilize THTs at points of capture approximately 10% of the time. Failure to position trained HUMINT Soldiers close to points of capture puts a burden on units farther up the chain of custody and delayed the collection of timely intelligence. The backlog of unscreened detainees quickly overwhelmed the internment

system in OIF, where I/R facilities were unprepared to deal with such large numbers of detainees. This slowed the process of intelligence exploitation and prevented the timely release of detainees who were apprehended and later found to have no intelligence value and to be of no threat to Coalition Forces.

If performed by trained interrogators, front-line interrogations offer other advantages. Recently captured persons are less likely to resist the interrogator. They also have not yet entered the general detainee population where they can conspire with others to resist interrogation techniques. In untrained hands, however, these advantages can be lost. To satisfy the need to acquire intelligence as soon as possible following capture, some officers and noncommissioned officers (NCOs) with no training in interrogation techniques began conducting their own interrogation sessions. Inexperienced and untrained persons using unproven interrogation techniques often yield poor intelligence and can harden detainees against future questioning by trained interrogators. The potential for abuse increases when interrogations are conducted in an emotionally-charged environment by untrained personnel who are unfamiliar with the approved interrogation approach techniques. The quality of these interrogations was further eroded by the absence of Category II interpreters. Category I interpreters—local nationals without security clearances—were the only interpreters available in forward locations, and there was no way to guarantee the accuracy or trustworthiness of their work.

The Military Intelligence (MI) School has internally resourced a mobile training team (MTT) to offset the shortage of interrogators in the field. The MTT trains non-MI personnel in the skills and knowledge required to perform basic questioning techniques and operations in order to enhance ongoing HUMINT collection missions at the tactical level. Tactical questioning (TQ) is a critical element of small unit operations. Tactical Questioning (TQ) is defined as the questioning of the local population (noncombatants and enemy prisoners of war (EPWs)/detainees) for information of immediate tactical value. Through TQ, the handling of detainees, and the handling of captured documents, Soldiers serve as the commander's eyes and ears. The information that the Soldiers report as a result of TQ is passed up the chain of command and forms a vital part of planning and operations. The TQ MTT has trained approximately 4000 Soldiers as of March 2004.

Current military interrogation procedures as published in FM 34-52, Intelligence Interrogations, 28 September 1992, and taught at the U.S. Army Intelligence Center, Fort Huachuca, remain valid. Interrogation approach techniques, themselves, are addressed in Finding 9. Military interrogators receive 16.5 weeks of intensive training on interrogation procedures and techniques at the Army's Human Intelligence Collector Course. This training includes collection priority, screening, planning and preparation, approaches, questioning, and termination of interrogations. A total of 192 hours of direct and indirect training on the laws of land warfare emphasizes compliance of all military interrogation techniques with the Geneva Conventions and Army policy. Prohibited activities are covered in detail and reinforced in interrogation operation exercises.

Interrogation approach techniques policies were issued for OEF and OIF. The CJTF-7 Commander issued initial interrogation approach techniques policy on 14 September 2003, and amended the interrogation approach techniques policy on 12 October 2003 and 13 May 2004. The CJTF-180 Commander issued approved interrogation approach techniques policy on 16 March 2004.

The DAIG Team observed 2 detainee facilities using digital video recording devices, 1 in Afghanistan and 1 in Iraq. Because interrogations are confrontational, a monitored video

recording of the process can be an effective check against breaches of the laws of land warfare and Army policy. It further protects the interrogator against allegations of mistreatment by detainees and provides a permanent record of the encounter that can be reviewed to improve the accuracy of intelligence collection. All facilities conducting interrogations would benefit from routine use of video recording equipment.

In summary, the DAIG Team found the quantity and distribution of military interrogators were insufficient to conduct timely intelligence exploitation of non-compliant detainees in OEF and OIF. Military interrogators observed in OEF and OIF were performing interrogations of detainees in accordance with doctrine.

(4) Root Cause: The shortages of interrogators and interpreters at all echelons caused commanders and other leaders to use untrained personnel to conduct interrogations of detainees. Insufficient numbers of Category II interpreters, especially those with experience working with interrogators, further hampered interrogation operations.

(5) Recommendation: TRADOC and G2 ensure documentation of unit organizations meet interrogator personnel manning requirements, authorizations, and capabilities in order to provide commanders with timely intelligence.

Recommendation: The CFLCC contracting officer representative ensure enough Category II interpreters are hired to support timely intelligence exploitation of detainees.

d. Finding 7:

(1) Finding: Tactical Military Intelligence officers are not adequately trained on how to manage the full spectrum of the collection and analysis of human intelligence.

(2) Standard: See Appendix E.

(3) Inspection Results: Interviewed Military Intelligence (MI) leaders and Soldiers indicated that G2s and S2s were conducting interrogations of detainees without the proper training on the management of Human Intelligence (HUMINT) analysis and collection techniques. They were not adequately trained to manage the full spectrum of HUMINT assets being used in the current operating environment. The counterintelligence team leaders (TL) interviewed expressed a wish that all G2s and S2s were trained on how to manage the collection and analysis of HUMINT. The need for these officers to understand the management of HUMINT operations is the key for successful HUMINT exploitation in the current operating environment. Battalion commanders, company commanders, and platoon leaders were interrogating detainees at the point of capture according to counterintelligence TLs interviewed. They complained about this practice because these leaders were not properly trained in interrogation techniques and quite possibly jeopardized the intelligence gathering process to acquire timely intelligence from detainees. Counterintelligence TLs were told on several occasions by these leaders that they had the interrogations under control and did not require their Military Intelligence (MI) assistance.

Currently, MI officers only receive a general overview of HUMINT during their Professional Military Education (PME) courses. During the Military Intelligence Officer Basic Course (MIOBC), MI officers receive a 9 day Intelligence Battlefield Operating System (IBOS) block of instruction which includes a 6-hour block on: review/reinforcement of counterintelligence/human intelligence principles; counterintelligence organizations; Subversion

& Espionage Directed Against U.S. Army & Deliberate Security Violations (SAEDA); and the role of the tactical human intelligence teams (THTs). Furthermore, the MIOBC students receive approximately an hour block of instruction from their Stability and Support Operations (SASO) instructor on displaced civilians/refugees on the battlefield.

MI Captain Career Course (MICCC) officers receive a one-hour block of instruction in their intelligence support to brigade operations (ISBO) on imagery intelligence (IMINT), counterintelligence/human intelligence, and signals intelligence (SIGINT). Additionally, during practical exercises the students receive 40 hours of Stability and Support Operations (SASO) training, 32 hours of threat training, and 2 hours of crime link training from their instructor. Also, during intelligence, surveillance, and reconnaissance planning the basic principles of counterintelligence/HUMINT are reinforced during practical exercises (30 minutes in length) that addresses IMINT, counterintelligence/HUMINT, and SIGINT being used on the battlefield to collect intelligence information. During the Intelligence Support Course to division, corps, and joint officers, there is one day of counterintelligence/HUMINT training. This training includes an overview, specific training, and a practical exercise for counterintelligence/HUMINT. Additionally, the 35E series (Counterintelligence Officer) course conducts counterintelligence/HUMINT training for 8 hours, and the Strategic Intelligence Officer Course conducts counterintelligence /HUMINT training for 5 hours.

Interviewed career course captains with experience in OPERATION ENDURING FREEDOM (OEF) and OPERATION IRAQI FREEDOM (OIF) from the Military Intelligence school stated their home station training on detainee operations was limited and concentrated on EPWs or compliant detainee populations. These officers stated the training they received at the MI Basic Course did not provide them with enough training to prepare them to conduct detainee or human intelligence gathering operations.

The G2, in coordination with TRADOC, has created a G2X/S2X Battle Staff Course to begin in July 2004 for MI officers. The G2X/S2X Battle Staff Course will prepare a G2X/S2X staff of a deploying Army division with the capability to synchronize, coordinate, manage and de-conflict counterintelligence and HUMINT sources within the division's area of responsibility (AOR). The G2X/S2X program of instruction (POI) will be tailored for a staff operating within a Joint or multi-national (Coalition) environment which will focus on real world missions, Army-centric, and counterintelligence/HUMINT tool-specific training. The G2X/S2X curriculum is based upon the counterintelligence/HUMINT critical tasks and incorporates J2X/G2X/S2X emerging doctrine/methodology and lessons learned. This course will be hands-on and application based. The G2X/S2X Battle Staff Course provides the critical knowledge and skills required to enable the G2X staff to successfully synchronize and monitor asset management to place sources against the combatant commander's target in support of the mission.

The G2, in coordination with the MI School, is currently revising Field Manual (FM) 34-52, Intelligence Interrogation, 28 September 1992. Additionally, the G2 is spearheading a coordinated effort with TRADOC and the U.S. Army Military Police School to synchronize between the 3 disciplines of intelligence, surveillance, and reconnaissance, particularly in the area of detainee handling and internment/resettlement facility management.

Interviewed and sensed leaders and Soldiers stated that the Law of War training they received prior to deployment did not differentiate between the different classifications of detainees causing confusion concerning the levels of treatment. Even though this confusion existed, the vast majority of leaders and Soldiers treated detainees humanely.

TRADOC, in coordination with the Office of the Judge Advocate General, is currently determining the feasibility of increasing or adjusting Law of War training in the proponent schools to include procedures for handling civilian internees and other non-uniformed personnel on the battlefield.

(4) Root Cause: The MI School is not adequately training the management of HUMINT to tactical MI officers. The MI School has no functional training course available to teach the management of HUMINT.

(5) Recommendation: TRADOC continue the integration of the G2X/S2X Battle Staff Course for all Military Intelligence officers assigned to G2X/S2X positions.

Recommendation: TRADOC integrate additional training on the collection and analysis of HUMINT into the Military Intelligence Officer Basic Course program of instruction.

e. Finding 8:

(1) Finding: The DAIG Team found that officially approved CJTF-7 and CJTF-180 policies and the early CJTF-180 practices generally met legal obligations under U.S. law, treaty obligations and policy, if executed carefully, by trained soldiers, under the full range of safeguards. The DAIG Team found that policies were not clear and contained ambiguities. The DAIG Team found implementation, training, and oversight of these policies was inconsistent; the Team concluded, however, based on a review of cases through 9 June 2004 that no confirmed instance of detainee abuse resulted from the approved policies.

(2) Standard: See Appendix E.

(3) Inspection Results: Interrogation approach techniques policy is identified by several different titles by the different commands of OEF and OIF. For the purpose of standardization of this report those titles will be referred to collectively as interrogation approach techniques policy.

Army doctrine found in Field Manual (FM) 34-52, Intelligence Interrogation, 28 September 1992, lists 17 accepted interrogations approach techniques. It states that those approach techniques are not inclusive of all possible or accepted techniques. The DAIG Team reviewed interrogation approach techniques policy for both OEF and OIF and determined that CJTF-180 and CJTF-7 included additional interrogation approach techniques not found FM 34-52. The DAIG Team found that officially approved CJTF-7 and CJTF-180 policies and the early CJTF-180 practices generally met legal obligations under Geneva Convention Relevant to Prisoners of War (GPW), the Geneva Convention Relative to the Protection of Civilian Persons in Time of War (GC), the UN Convention Against Torture and Other Cruel, Inhuman or Degrading Treatment or Punishment (CAT), the U.S. Torture statute, 18 USC §§2034, 2034A, if executed carefully, by trained soldiers, under the full range of safeguards. The DAIG Team found that some interrogators may not have received formal instruction from the U.S. Army Military Intelligence Center on interrogation approach techniques not contained in FM 34-52. Additionally, the DAIG Team found that while commands published interrogation approach policy, some subordinate units were unaware of the current version of those policies. Content of unit interrogator training programs varied among units in both OEF and OIF. However, no confirmed instance involving the application of approved approach techniques resulted in an instance of detainee abuse.

The 17 approved interrogation approach techniques listed in FM 34-52 are direct, incentive, emotional love, emotional hate, fear-up (harsh), fear-up (mild), fear-down, pride and ego-up, pride and ego-down, futility, we know all, file and dossier, establish your identity, repetition, rapid fire, silent, and change of scene. Approach techniques can be used individually or in combination as part of a cohesive, logical interrogation plan. These approach techniques are found in the current training curriculum at the Military Intelligence School. The FM states these approach techniques are "not new nor are all the possible or acceptable techniques discussed. Everything the interrogator says and does must be in concert with the GWS [Geneva Convention For the Amelioration of the Wounded and Sick in Armed Forces in the Field], GPW, GC and UCMJ [Uniform Code of Military Justice]." The FM further states, "Almost any ruse or deception is usable as long as the provisions of the GPW are not violated." Techniques considered to be physical or mental torture and coercion are expressly prohibited, including electric shock, any form of beating, mock execution, and abnormal sleep deprivation.

The FM gives commanders additional guidance in analyzing additional techniques. On page 1-9 it states: "When using interrogation techniques, certain applications of approaches and techniques may approach the line between lawful actions and unlawful actions. It may often be difficult to determine where lawful actions end and unlawful actions begin. In attempting to determine if a contemplated approach or technique would be considered unlawful, consider these two tests: Given all the surrounding facts and circumstances, would a reasonable person in the place of the person being interrogated believe that his rights, as guaranteed under both international and U.S. law, are being violated or withheld if he fails to cooperate. If your contemplated actions were perpetrated by an enemy against U.S. PWs [Prisoners of War], you would believe such actions violate international or U.S. law. If you answer yes to either of these tests, do not engage in the contemplated action. If a doubt still remains as to the legality of the proposed action, seek a legal opinion from your servicing judge advocate."

The FM lists four primary factors that must be considered when selecting interrogation approach techniques:

- (1) The person under interrogation's mental or physical state,
- (2) The person under interrogation's background and experience,
- (3) The objective of the interrogation, and
- (4) The interrogator's background and abilities.

The DAIG Team found some interrogation approach techniques approved for use at Guantanamo Bay were used in development of policies in OEF and OIF. As interrogation policy was developed for Joint Task Force (JTF) Guantanamo, the Commander, U.S. Southern Command requested additional approach techniques to be approved. A Working Group on Detainee Interrogations in the Global War on Terrorism was convened. This group was required to recommend legal and effective interrogation approach techniques for collection of strategic intelligence from detainees interned at Guantanamo Bay. The working group collected information on 39 existing or proposed interrogation tactics, techniques and procedures from the U.S. Central Command (CENTCOM) and U.S. Southern Command in a 6 March 2003 report. It recommended approval of 26 interrogation approaches.

A memorandum on 16 April 2003, entitled "Counter-Resistance Techniques" approved 26 specific techniques for use only by JTF Guantanamo. It required the use of 7 enumerated safeguards in all interrogations. The memorandum stated that the use of any additional interrogation techniques required additional approval. The instructions noted that the intent in

all interrogations was to use "the least intrusive method, always applied in a humane and lawful manner with sufficient oversight by trained investigators or interrogators."

Both CJTF-180 and CJTF-7 developed interrogation policies for intelligence exploitation operations in OEF and OIF. All policies contained additional interrogation approach techniques other than those identified in FM 34-52. The DAIG Team identified this occurred for three reasons: (1) Drafters referenced the JTF Guantanamo policy memorandum as a basis for development for their policy; (2) In two instances, published policy made reference to the 8 May 1987 version of FM 34-52 which listed a technique that was later removed from the 28 September 1992 revision; and (3) Some intelligence personnel believed that additional interrogation techniques would assist in more effective intelligence exploitation of a non-compliant or hardened detainee population. Both OEF and OIF included safeguards in their policy, although they differed from each other and from the 16 April 2003 memorandum applicable to JTF Guantanamo. Reliance on the Guantanamo policy appears to contradict the terms of the memorandum itself which explicitly states it was applicable to interrogations of unlawful combatants at JTF Guantanamo and failed to take into account that different standards applied to JTF Guantanamo, CJTF-180 and CJTF-7.

The DAIG Team found that CJTF-7 issued a series of evolving policy statements, while CJTF-180 only issued one policy. The DAIG Team, however, found evidence of practices that had been in effect in Afghanistan since at least early 2003. The DAIG Team reviewed the officially approved interrogation approach technique policies for both CJTF-7 and CJTF-180, and the record of practices in use in CJTF-180 prior to adoption of a formal policy. The changes in policies and practices, over time, reflect the struggle that commanders faced in developing approach techniques policies that were both effective and complied generally with legal obligations applicable to the theater. In Iraq, in particular, the commander was faced with a group of detainees that ranged from Enemy Prisoners of War (EPW's), to security internees (SI's) to unlawful combatants. In both theaters, commanders were operating under combat conditions, facing the death and wounding of scores of U.S. soldiers, civilians and other non-combatants on a daily basis. Their decisions and decision-making process must be viewed against this backdrop.

The DAIG Team found that officially approved CJTF-7 and CJTF-180 policies and the early CJTF-180 practices generally met legal obligations under U.S. law, treaty obligations and policy, if executed carefully, by trained soldiers, under the full range of safeguards. The approved policies, however, presented significant risk if not executed in strictest compliance with their own safeguards. In this light, the caution noted in FM 34-52 (above) appears applicable, "It may often be difficult to determine where lawful actions end and unlawful actions begin." In a high-stress, high pressure combat environment, soldiers and subordinate leaders require clear, unambiguous guidance well within established parameters that they did not have in the policies we reviewed.

The DAIG Team found that the established policies were not clear and contained ambiguity. The absence of clarity could have been mitigated by additional training, detailed planning and brief-backs, detailed case-by-case legal analysis and other command and staff execution safeguards. In the absence of the safeguards, however, the commands could have embarked on high risk interrogation operations without adequate preparation or safeguards. Contributing to the ambiguity were command policies that included both approved techniques and security and safety provisions. While some security provisions provide a secondary benefit to an interrogation, it is not proper to use the security provision solely for the purpose of causing this secondary benefit in the interrogation. Both the CJTF-180 and CJTF-7 policies and the

known CJTF-180 practices prior to their first published policy, imprudently mixed discussion of security provisions into interrogation techniques. This added to the possible confusion regarding whether a particular action was truly a security provision or an interrogation technique. While the language of the approved policies could be viewed as a careful attempt to draw the line between lawful and unlawful conduct, the published instructions left considerable room for misapplication, particularly under high-stress combat conditions.

Application of the additional techniques involving higher risk of violations required additional training for interrogators. Formal school training at the U.S. Army Intelligence Center and School (USAICS) for both MOS 97E, Enlisted Human Intelligence Collector, and 351E, Warrant Officer Human Intelligence Collection Technician, provides instruction on the interrogation approach techniques identified in FM 34-52. The DAIG Team identified that interrogators only received training on doctrinal approach techniques listed in FM 34-52 from the USAICS, however, some interrogators may have received training on the additional approach techniques at the unit level. Interviewed intelligence personnel stated they were also trained on the additional approaches through mobile training teams. In some organizations, the team found a comprehensive unit training program; in others, the team found no formal or standardized interrogator training program. Inadequately trained interrogators present an increased risk that the approach technique will be improperly applied. The team found no indication that a lack of training resulted in an improper application of any particular technique or techniques; however, it remains critical that units applying any of the additional interrogation approach techniques have a comprehensive training program as a risk mitigation measure for those higher risk techniques.

The DAIG Team observed that although both CJTF-180 and CJTF-7 published interrogation approach technique policies, some inspected units were unaware of the correct command policy in effect at the time of inspection. The differences noted were omission of approved approach techniques and failure to note that a particular approach technique required higher command approval. The team was unable to determine if inspected units with incorrect versions of higher headquarters policy had requested authorization to use, or had used, any of the additional techniques. The unit policies did include safeguards consistent with the higher headquarters policy. As with other sensitive changes in unit mission orders, commanders should ensure that they have an effective feedback mechanism to ensure subordinate units receive, acknowledge and comply with changes in approved approach techniques.

Interviews and sworn statements from personnel in both CJTF-180 and CJTF-7 indicated that some of the approach techniques included in their policies, but not listed in FM 34-52, were used by some interrogators. The DAIG team found no indication of the frequency or consistency with which these additional approach techniques were employed. The DAIG Team conducted a review of 125 case summaries from the Criminal Investigation Division (CID) and unit investigations available as of 9 June 2004. Based on a review of case summaries, and despite the significant shortcomings noted in the command policies and practices, the team was unable to establish any direct link between the use of an approved approach technique or techniques and a confirmed case of detainee abuse.

(4) Root Cause: Commanders perceived interrogation approach techniques found in FM 34-52 were insufficient for effective intelligence exploitation of non-compliant detainees in OEF and OIF and published high risk policies that presented a significant risk of misapplication if not trained and executed carefully. Not all interrogators were trained on all approved approach techniques.

(5) Recommendation: TRADOC, in coordination with G2 and TJAG, revise doctrine to identify interrogation approach techniques that are acceptable, effective and legal for non-compliant detainees.

Recommendation: CJTF-7 and CJTF-180 ensure that standardized policy on interrogation approach techniques are received, understood, trained and enforced by all units.

Chapter 5

Other Observations

1. **Summary of Findings:** We examined seven key systems (Leadership and Discipline, Policy and Doctrine, Military Intelligence/Military Police Relationship, Organizational Structures, Facilities, Resources, and Training and Education) that influence how detainees are handled throughout the detention process, including interrogations. In the course of that examination we identified a number of observations that while not critical, require attention and resolution. None of the findings contributed directly to any specific case of abuse. The recommendations accompanying the 15 following findings are designed to improve our ability to properly conduct detainee operations.

2. **Findings:**

a. **Finding 9:**

(1) **Finding:** Interviewed leaders and Soldiers stated the unit's morale (71%) and command climate (68%) had steadily improved due to competent leadership, caring for Soldiers by leaders, and better working and living conditions as the theater matured.

(2) **Standard:** See Appendix E.

(3) **Inspection Results:** We attempted to determine the effect of stress and morale on detainee operations and conducted a Combat/Operational Stress Survey. We interviewed or sensed more than 650 leaders and Soldiers and received 603 of the surveys back. The DAIG Team found that 71% (428 of 603) of leaders and Soldiers surveyed stated the unit's morale, (71%, 428 of 603) and command climate (68%, 410 of 603) had steadily improved in OPERATION ENDURING FREEDOM (OEF) and OPERATION IRAQI FREEDOM (OIF). The survey results found that leaders and Soldiers perceived that morale and the command climate was good. The results of the survey, interviews, and sensing sessions showed that the morale and command climate improved due to competent leadership, caring for Soldiers by leaders, and better working and living conditions as the theater matured. The DAIG Team also found that most perceptions of morale and command climate varied widely between senior leaders, junior leaders, and Soldiers. The morale and command climate perception was higher for those interviewed and surveyed leaders and Soldiers who deployed prior to November 2003 and had redeployed from OEF/OIF than those that were still in country or arrived after the first of the year when living conditions started to improve.

The morale and command climate perceptions varied depending upon the difficulty of the unit's mission and its location. Soldiers conducting detainee operations in remote and dangerous locations complained of very poor to poor morale and command climate due to the lack of higher command involvement and the perception that their leaders did not care. These Soldiers stated that the leadership from higher commands hardly ever visited their locations, they were living in much worse conditions than other Soldiers, they suffered increased dangers, they were untrained to perform their mission, and the work schedule/lack of personnel depth caused them to "burn out."

Of the Soldiers who arrived in theater since November/December 2003 (61%, 194 of 318), expressed morale as good to excellent, while 51% (145 of 285) of Soldiers who deployed during the initial stages of OEF/OIF complained of poor morale, but also expressed that it seemed to get better with time.

Most Soldiers talked of how morale improved as living and working conditions improved. A majority of Soldiers mentioned the arrival of air conditioning, installation of Internet cafes, rest and recuperation (R&R) trips to Qatar, and environmental leave as some of the things that improved morale. Many engaged in Morale, Welfare, and Recreation (MWR) activities, such as weight lifting, basketball, softball, billiards, and ping-pong. Many enjoyed TV, hot meals, satellite phones, volleyball, and MWR bands in some locations. Soldiers were very pleased with how the leaders helped and listened to them more than they had before. The majority of Soldiers got more downtime or time off when possible. Most leaders expressed a need to continue to obtain more comfort items sooner to speed up improvements in living conditions as a measure to boost the morale.

The survey was given to every leader and Soldier that was interviewed and in sensing sessions both in theater and CONUS. The survey revealed that the majority of leaders and Soldiers agreed that unit members can depend, cooperate, and stand up for each other, which are factors of having good unit morale. In addition, leaders and Soldiers were told when they were doing a good job, were not embarrassed in front of peers, and were not assigned extra missions by leadership to look good for the chain of command, which are some indicators that there is a perception of a good command climate. Although the morale and command climate was poor under certain conditions, it steadily improved as living conditions in the theater improved over time.

(4) Recommendation: CFLCC, CJTF-7, and CJTF-180 continue to stress the importance of positive unit morale and command climate.

b. Finding 10:

(1) Finding: Detainee administration, internment, and intelligence exploitation policy and doctrine does not address detainee operations conducted in the current operating environment, which has a higher demand for human intelligence exploitation at the tactical level and the need for additional classifications of detainees.

(2) Standard: See Appendix E.

(3) Inspection Results:

POLICY

Although classified detainee operations policy has been issued to address individual situations at specific geographic locations, current published detainee operations policy in AR 190-8, Enemy Prisoners of War, Retained Personnel, Civilian Internees and Other Detainees, 1 October 1997, does not address additional definitions of detainee designations and related treatment requirements. In addition to enemy prisoners of war (EPWs) in OPERATION IRAQI FREEDOM (OIF) and compliant, non-hostile civilian internees (CIs) in OPERATION ENDURING

FREEDOM (OEF) and OIF, units were faced with capturing, transporting, segregating and controlling other categories of detainees, such as non-state combatants and non-compliant CIs. AR 190-8 also does not address the relationship between mission requirements for re-establishing a civilian prison system and detainee operations. Policy must address requirements for expanded employment of confinement expertise for managing detainee security, custody, and control challenges for a wider array of detainee designations. Policy must also address the confinement expert's role in standing up indigenous prison systems, enabling rapid segregation and transfer of criminal detainee populations from U.S. Forces to indigenous control.

The DAIG Team found the addition of new detainee administrative policy classifications of detainees resulted in inconsistent administrative procedures. Current doctrine, regulations, and policy are based on a linear battlefield and a largely compliant population, with the primary goal of removing individuals from the battlefield. In addition to EPWs and compliant, non-hostile CIs, units in OEF and OIF were confronted with capturing, transporting, processing, and confining other classifications of detainees, such as non-state combatants and non-compliant CIs. The nature of the environment in which we now conduct detainee operations requires a more specific classification of the detainees interned. Instead of compliant, non-hostile detainees, units are capturing and transporting non-state combatants, insurgents, criminals, and detainees who are either known or perceived security threats. Policy needs to be updated to address the management of detainees captured and detained primarily for intelligence exploitation, the potential security threat they may pose, or the pending reestablishment of indigenous prison systems.

Army Regulation (AR) 190-8, Enemy Prisoners of War, Retained Personnel, Civilian Internees and Other Detainees, 1 October 1997, accords appropriate legal status using four detainee classifications: EPW, Retained Personnel (RP), CI, and Other Detainees (OD). In OEF and OIF, various fragmentary orders, policy memorandums, and unit standing operating procedures utilized several variations on these classifications, including Enemy Combatants, Under-privileged Enemy Combatant, Security Internee, Criminal Detainee, Person Under U.S. Forces Control (PUC), and Low Level Enemy Combatant (LLEC). In accordance with AR 190-8, administrative and treatment requirements are based on the classification assigned to a particular detainee. For example, detainees are to be segregated in facilities according to their status. The development of classifications not correlated to one of the four terms defined in AR 190-8 resulted in confusing and ambiguous requirements for those charged with managing detainees and created the potential for inconsistent treatment. From points of capture to internment/resettlement (I/R) facilities, there are varying degrees of understanding as to which standards apply to the various classifications of detainees in OEF and OIF. Policy does not specifically address administrative responsibilities related to the timely release of detainees captured and detained primarily for intelligence exploitation and/or the potential security threat they may pose. Administrative processing of detainees by units in OEF and OIF was not standardized or fully compliant with policy and doctrine.

The time between capture and receipt of an Internment Serial Number (ISN) at an I/R facility far exceeded the time specified in policy and doctrine. Once the detainee reached an I/R facility, the required documentation received from collecting points (CPs) was often incomplete. The National Detainee Reporting Center (NDRC) did not receive all mandatory data elements, or in a timely manner, as detainee designation was often not determined until long after capture. From points of capture to corps holding areas, detainees are to be moved "as soon as practical"

depending on the condition of the detainee, the threat faced in moving them, and military necessity. The non-linear nature of the battlespace and missions dependent on human intelligence made administrative processing a secondary priority to intelligence exploitation of detainees. This had additional second- and third-order effects on accountability, security, and reporting requirements for detainees. Detaining individuals primarily for intelligence collection or because of their potential security threat, though necessary, presented units with situations not addressed by current policy and doctrine.

Administrative processing is further hampered by the absence of the Branch Prisoner of War Information Center (now called the Theater Detainee Reporting Center (TDRC)), the central agency in theater required by policy to manage information on all EPW, CI and RP and their personal property. This resulted in missing data on individual detainees, poor detainee and property accountability, and the inability of the NDRC to completely and accurately report all required data elements to the DoD, the Army, and other appropriate agencies. Inadequate property accountability could also result in claims against the U.S. government for losses incurred by detainees while in U.S. custody.

According to Department of Defense Directive (DoDD) 2310.1, DoD Program for Enemy Prisoners of War (EPOW) and Other Detainees, 18 August 1994, the transfer of detainees to or from the custody and control of U.S. Forces requires the approval of the Assistant Secretary of Defense for International Security Affairs (ASD(ISA)). In OEF, oversight of detainee operations policy was transferred from ASD(ISA) to the Assistant Secretary of Defense for Special Operations and Low Intensity Conflict (ASD(SO/LIC)) in a memorandum dated 17 January 2002. SUBJECT: Responsibility for Detainees in Association with the Global War on Terrorism. In OIF, ASD(ISA) maintained transfer authority under DoDD 2310.1 for most detainees, but ASD(SO/LIC) had authority under the 17 January 2002 memorandum for specific classifications of detainees. Release decisions were made by commanders or review boards at multiple echelons of detention in OIF, from points of capture to the Detainee Release Board (DRB) developed by CJTF-7. The DAIG Team did not find evidence of ASD(ISA) oversight of release decisions in OIF.

Complex detainee release mechanisms contributed to overcrowding of I/R facilities. Multiple reviews were required to make release recommendations prior to approval by the release authority. Non-concurrence by area commanders, intelligence organizations or law enforcement agencies resulted in retention of larger numbers of detainees. Interviews with the CJTF-7 Chief Magistrate, Appeal & Review Board members, and Release Review Board members indicated they believed up to 80% of detainees being held for security and intelligence purposes might be eligible for release upon review of their cases with the other 20% either requiring continued detention due to security reasons or continued intelligence requirements. Interviews also indicated area commanders were reluctant to concur with some release decisions out of concern that potential combatants may be re-introduced into their areas of operation. The Ryder Report referenced the overcrowded conditions and recommended holding Iraqi magistrate proceedings at individual facilities, reducing the requirement to manage many detainees centrally. Release of those individuals locally would substantially reduce the detainee population and the related resources and manpower, and would improve the capability to manage the remaining population. The remaining detainee population would be made up of only those criminals awaiting the restoration of the Iraqi prison system, those who are under active or pending interrogation, or those being held for specific security reasons.

During interviews and sensing sessions, the DAIG Team noted all Active Component and Reserve Component leaders indicated that current detainee operations policy was not consistent with the requirements of ongoing operations in OEF and OIF. Detainee operations policy must reflect requirements of the Future Force for strategic and operational versatility—conducting combat and stability operations simultaneously—while operating in a joint environment. As Army Transformation continues, detainee operations policy should be appropriate for and responsive to the requirements of non-linear battlespaces. Policy should provide specific guidance for a wider array of detainees who have significantly varying security requirements. This will reduce confusion in relation to the applicability of these requirements to various categories of detainees.

The Ryder Report points to several areas where current policy is not sufficient for detainee operations. It stated that, ". . . more detailed instructions in areas such as discipline, instruments of restraint, and treatment of prisoners awaiting trial. . ." are needed. The report suggested that the 800th MP Brigade's challenges in adapting its organizational structure, training, and equipment resources to expand from a purely EPW operation to also managing Iraqi and third country national detainee populations can be attributed to a lack of policy guidance. The Taguba Investigation also points to a lack of sufficient policy and training on existing policy.

The DAIG Team concluded DoD-developed classifications of detainees were different from those found in AR 190-8 and led to inconsistent segregation of these groups as directed by policy. The lack of an adequate system-wide capacity for handling detainees, the lack of specific policy on adequacy of information/evidence collection, and the lack of an operating detainee release process at all echelons, along with the perceived need to conduct interrogations closer to the point of capture, caused units to retain detainees beyond doctrinal time periods and without properly segregating the various classifications of detainees. The decision by capturing units to hold and interrogate detainees also interfered with the policy requirements for accountability of detainees and their property within the system, leading to substantial delays in determining an individual's status and his/her subsequent disposition. Policy must address the appropriate, safe, secure, and humane custody of detainees, the specialized confinement skills required in a high-risk detainee I/R setting, and the need for timely intelligence exploitation of detainees in a non-linear battlespace. Lack of a TDRC contributed to units' failure to administratively process detainees in accordance with all regulations and policy, and the loss of theater-wide detainee and property accountability. Incomplete documentation and a cumbersome review process caused detainees to be held for extended periods of time and contributed to the overcrowding of I/R facilities.

DOCTRINE

Current doctrine was designed to quickly evacuate compliant, non-hostile enemy prisoners of war (EPWs) and CIs from point of capture to I/R facilities. It does not envision the demands of gaining immediate, tactical human intelligence, hence the requirement to detain and interrogate at lower levels. The nature of OEF and OIF battlespaces, coupled with the urgent need for human intelligence (HUMINT), compelled many units to adapt their tactics, techniques, and procedures (TTPs) for conducting detainee operations. While the necessary basic skill sets and organizational responsibilities contained in current detainee operations doctrine remain applicable, the procedural timelines for detainee processing and movement from the point of capture to the I/R facilities do not consider current operational needs. Also the unit task

organizations for detainee processing and movement are not properly resourced to meet many of the challenges faced in OEF and OIF.

During interviews and sensing sessions, the DAIG Team noted leaders and Soldiers indicated current detainee operations doctrine was not consistent with the requirements of ongoing operations. According to current doctrine, the swift flow of detainees to the rear is critical in getting them to trained interrogators for intelligence exploitation, and to secure them in I/R facilities designed and operated for long-term internment. Under present doctrine, combat units must rely on support elements from other units to perform many mission-related tasks (e.g., MPs to provide escort and guard functions, and Tactical Human Intelligence (HUMINT) Teams (THTs) to screen detainees at points of capture and forward collecting points (CPs)). While current doctrine is meant to relieve combat formations of the significant manpower and logistical requirements for managing detainees before they have a negative impact on combat effectiveness, it has failed to do so in OEF and OIF. Current doctrine does not address a non-linear battlespace where units at division level and below hold detainees for extended periods of time to provide commanders with intelligence for the conduct of effective tactical operations. Traditional task organizations are not properly resourced to meet the needs of this new operating paradigm.

Standing operating procedures (SOPs) for CPs and I/R facilities that were drafted by units prior to deployment (and in accordance with current doctrine) were found early on to be outdated based on the current operating environment for OEF and OIF. Soldiers were required to perform effectively in a variety of missions across a spectrum of operations. Units quickly found themselves taking on roles in detainee operations which were unanticipated. For example, the need for timely intelligence compelled officers and Noncommissioned officers (NCOs) in combat units to conduct tactical questioning even though none had been trained in proper interrogation TTPs. Manpower shortages at CPs and I/R facilities were satisfied by using in lieu of (ILO) units; most received little or no training in detainee operations.

The limitations of current doctrine meant that mission, enemy, terrain and weather, time, troops available, and civilian (METT-TC) considerations often drove the design and operations of division CPs and battalion and company CPs. This had negative second- and third-order effects on the accountability, intelligence exploitation, security, and safeguarding of detainees. Instead of capturing and rapidly transporting detainees to doctrinal CPs, battalions and companies were holding detainees for up to 30 days without the training, materiel, or infrastructure for doing so. The desire for timely intelligence, transportation and security concerns, and delays in administrative processing caused units at all echelons to retain detainees for periods of time that exceeded those recommended by doctrine. While adapting and operating outside of established doctrine is necessary and desirable, especially when current doctrine fails to meet the needs of ongoing operations, doing so carries with it a requirement to ensure that mission effectiveness is not hampered while ensuring safeguards are in place to prevent unsanctioned activities and meet other established requirements.

The DAIG Team observed and determined through interviews and sensing sessions that capture information was often incomplete when detainees were processed at detention locations. Capturing units lacked knowledge of procedures for information and evidence collection, critical for the accurate disposition of detainees. This was particularly apparent as OIF 2 units began deploying into theater and new commanders were faced with making release decisions based on insufficient information and documentation. The lack of required information

and specificity resulted in an administrative processing backlog at all echelons of internment. CPs and I/R facilities now require capturing units to have complete documentation prior to the transfer of a detainee into their custody.

Current interrogation doctrine for intelligence preparation of the battlefield and the composition and structure of interrogation assets does not adequately cover the current operational environment. Field Manual (FM) 34-52, Intelligence Interrogation, 28 September 1992, describes military interrogation approaches that remain valid, but the FM may not include all acceptable and effective techniques. Army interrogators receive 16.5 weeks of intensive training on interrogation procedures and techniques at the Human Intelligence Collection Course. This training includes collection priority, screening, planning and preparation, approaches, questioning, and termination of the interrogation. Specific instruction on the laws of land warfare emphasizes compliance of all Army interrogation TTPs with the Geneva Conventions and Army policy. All Army interrogators interviewed in OEF and OIF stated they were performing interrogations of detainees in accordance with policy and doctrine.

The Ryder Report and Taguba Investigation indicated deficiencies in detainee operations doctrine. The Ryder Report noted significant variances from doctrine and highlighted the need for changes in current doctrine to address the "significant paradigm shift" in detainee operations. The report, however, does not provide information on specific instances where doctrine needs to be revised. (The report did state, "the team will forward suggested doctrinal and organizational changes to the appropriate proponent schools for review and action.") The Taguba Investigation of the 800th MP Brigade found, "basic Army doctrine was not widely referenced or utilized to develop the accountability practices throughout the 800th MP Brigade's subordinate units." Procedures were "made up," with "reliance on, and guidance from, junior members of the unit who had civilian corrections experience." The relevance of current doctrine to present and future operations was beyond the scope of the Taguba Investigation. The DAIG Team found the statements made in these earlier reports to be consistent with the results of this inspection.

Findings from interviews, sensing sessions, and direct observations of AC and RC units consistently indicated that current doctrine fell short in preparing Soldiers to conduct detainee operations in the fluid and dynamic environment of OEF and OIF. Detainee operations doctrine needs to fulfill the requirement of the Future Force for strategic versatility—conducting combat and stability operations simultaneously—while operating in a joint environment with relative independence and at a high operational tempo. As Army Transformation continues, detainee operations doctrine needs to be appropriate for, and responsive to, the requirements of asymmetric battlespaces, the role of non-State belligerents, and modular force structures.

(4) Root Cause: Current doctrine and policy does not provide adequate guidance for detainee operations in OEF and OIF.

(5) Recommendation: TRADOC revise doctrine for the administrative processing of detainees to improve accountability, movement, and disposition in a non-linear battlespace. And further examine processes for capturing and validating lessons learned in order to rapidly modify doctrine and incorporate into training application for Soldiers and units.

Recommendation: The Provost Marshal General revise policy for the administrative processing of detainees to improve accountability, movement, and disposition in a non-linear battlespace

Recommendation: The Provost Marshal General, in coordination with the G2, update detainee policy to specifically address the administration, internment/resettlement, and intelligence exploitation in a non-linear battlespace, enabling commanders to better manage resources, ensure safe and secure custodial environments, and improve intelligence gathering.

c. Finding 11:

(1) Finding: Shortfalls in both the Military Police and Military Intelligence organizational structures resulted in the tactical unit commanders adjusting their tactics, techniques, and procedures to conduct detainee operations.

(2) Standard: See Appendix E.

(3) Inspection Results:

DOCTRINE

Doctrine indicates that Military Police (MP) units accept detainees from capturing units as far forward and as rapidly as possible. MPs operate divisional forward collecting points (CPs), divisional central CPs, and corps holding areas (CHA). MP units operating CPs and CHAs have the responsibilities to sustain, safeguard and ensure sick and wounded detainees receive medical treatment.

A platoon from the division MP company operates the forward CPs and should hold detainees for no more than 12 hours before transporting detainees to the central CP. The central CP should not hold detainees for more than 24 hours before transporting detainees to the CHA. Units will protect the detainees from enemy attacks and provide medical support, food, potable water, latrine facilities, and shelter. Detainee property is tagged with part C of Department of Defense (DD) Form 2745, Enemy Prisoner of War Capture Tag, and given to the escort guards. The MP leader will request transportation through logistic channels to transfer detainees from the forward CP to the central CP with the same procedures to transport the detainees to the CHA.

The CHA is operated by a platoon or company from a corps MP battalion and should not keep detainees for more than 72 hours. The decision to hold detainees longer is based on mission, enemy, terrain, time, troops available and civilian (METT-TC) considerations and the availability of forces. An MP platoon can guard 500 detainees, while an MP company can guard 2,000 detainees. As the population of the CHA increases, detainee evacuations to the internment/resettlement (I/R) facility also increase. Logistical requirements for food, water, medical care and sanitation must be considered. Locations for use by Military Intelligence (MI) interrogators need to be identified. The MP leader will request transportation through logistic channels to transport detainees from the CHA to the I/R facility.

The I/R facilities provide appropriate segregation, accountability, security, and support of detainees. An I/R facility is semi-permanent and normally consists of one to eight compounds,

with each compound capable of interning 500 detainees. The facility is operated by the HHC, MP battalion (I/R) (EPW/CI/DC) which provides command and control, administrative, and logistics functions to operate the facility. The battalion is capable of interning and supporting 4,000 enemy prisoner of war (EPWs) and civilian internees (CIs) or 8,000 dislocated civilians (DCs). An MP company (Guard) is assigned to provide guards for EPWs, CIs, and DCs, at the I/R facility. The company is capable of securing 2,000 EPWs, 2,000 CIs, or 4,000 DCs. The MP company (Escort Guard) provides supervision and security for evacuating and moving EPWs, CIs, DCs and other detained persons via vehicles, trains, aircraft, and road marches. The minimal security requirements for the facility include clear zones, guard towers, lights, sally ports, communications, and patrol roads. The MP and support personnel accepting detainees into the facility will search the detainee, conduct medical screening, perform administrative accountability, photograph and fingerprint as needed, account for personal property, and review records.

Doctrinally the first location an interrogation could take place is at the brigade. The interrogation teams are temporarily attached to the brigade from the division MI battalion interrogation section. The teams at the brigade level are strictly tactical and deal with information of immediate value. Interrogators are not usually assigned below the brigade level unless the combat situation requires limited tactical interrogation at battalion or company. Interrogations below brigade level are brief and concerned with information bearing directly on the combat mission of the capturing unit. This information is immediate tactical intelligence that is necessary for mission accomplishment and permits rapid reaction based on the information obtained.

In addition, MP personnel and MI interrogator teams at CPs and CHAs need to work closely together to determine which detainees, their personal belongings, and completed paperwork will offer intelligence information that would be useful to the command. The MI interrogators must support operations from brigade to theater level. Interrogators have to be highly mobile, and have communication equipment to report timely intelligence information to the supported commander.

Units conducting detainee operations in OPERATION ENDURING FREEDOM (OEF) and OPERATION IRAQI FREEDOM (OIF) adapted tactics, techniques, and procedures to make up for organizational shortfalls and to fill the void in doctrine resulting from the current operational environment.

OPERATION ENDURING FREEDOM

In OEF, units at point of capture processed their detainees at a non-doctrinal company CPs that held the detainees for up to 72 hours before releasing them or transporting them to higher headquarters. Detainees were held longer than 72 hours if required for intelligence purposes. Battalion Tactical Human Intelligence (HUMINT) Teams (THTs) sent to the company were extremely successful in gathering intelligence information from the detainees. If the THT was not available, the commander determined whether to detain or release a detainee after screening. MP personnel were not assigned to these company CPs, so the forward units had to provide their own guard force for the detainees. This additional duty took Soldiers away from performing their combat mission, which decreased the combat effectiveness of the unit. To process a detainee into the CP, the unit had to complete all required paperwork. The unit inventoried and tagged detainee personal property which would accompany the detainee when

he was repatriated or transferred to another location. The unit also tracked detainees with a Department of the Army (DA) Form 2708, Receipt of Inmate or Detained Person, when they were transferred to another location. The company CP provided detainees with food, water, shelter, and limited medical treatment.

The battalion CP held anywhere from 11 to 24 detainees for a period of 2 to 30 days. The battalions operating the CPs received sufficient information from the point of capture units to aid in their processing of the detainees. The interrogators examined all evidence before they began interrogating a detainee. When there was no THT present, commanders screened detainees for their intelligence value to determine if they should be released or transferred to the I/R facility. The determination to retain or release detainees at lower levels helped to ease the backlog of detainees requiring screening and questioning at higher locations. There were no MP personnel assigned to the battalions to support the battalion CPs. The battalions drew guards from their subordinate companies to act as a guard force for the detainees. This requirement to guard detainees diverted Soldiers from performing their combat mission and decreased the combat effectiveness of the unit. The unit leadership supervised its Soldiers to ensure detainees were protected, accounted for, and safeguarded. The unit provided detainees with food, bottled water, shelter, and limited medical treatment. The unit evacuated detainees by air or tactical vehicles to higher level facilities.

The division central CP at Kandahar was operated by platoons from an MP Company. The MP personnel in-processed the detainees, inventoried their personal property on a DA Form 4137, Evidence/Property Custody Document, placed their items in bags (if they would fit) or large suitcases and other items. A copy of the inventory sheet was placed inside with the property (with the detainee internally generated identification number) and stored the property in a secure area. The detainees were physically searched, checked for injuries, digitally photographed, and if sick or wounded, evacuated to a medical treatment facility (MTF) for treatment. The central CP held anywhere from 23 to 40 detainees. Most detainees were repatriated or transferred within 72 hours of arrival at this location, however detainees could be held longer for intelligence exploitation. MP guards escorted detainees to the interrogators and remained in close proximity during the interrogation. Since the detainees did not leave the facility, there was no custodial transfer of detainees to interrogators. When an interrogator requested to screen detainee personal effects prior to the interrogation, the MP guard would have the interrogator sign for the items prior to releasing them. The unit provided detainees with food, bottled water, shelter, blanket, Qur-an, medical treatment and showers for personal hygiene. CP personnel transported detainees by air to the I/R facility.

Detainees were held at the Bagram I/R facility for an unspecified length of time. The facility could house up to 275 detainees and, at the time of the inspection, housed 175. The I/R facility was operated by an MP battalion. The MP battalion did not deploy with two of its organic MP companies, but was augmented with two Reserve Component (RC) MP companies, one company was an MP company (combat support) and the other was an MP company (guard), to aid them with the internment duties. Upon a detainee's arrival, the MPs in-processed the detainee's personal effects and accounted for the items on a DA Form 4137. The evidence custodian signed for the property and stored it in a secure area. The detainee was photographed, received a medical screening including height and weight, was issued a jumpsuit, showered and shaved, and then was photographed again. The MP guards escorted the detainee to the interrogators and remained in close proximity to the interrogation. Since the detainee did not leave the facility there was no custodial transfer of the detainee to the

interrogator. If the detainee was transferred outside the facility, a DD Form 2708, Receipt of Inmate or Detained Person, was completed and signed to maintain accountability. Upon return the detainee received a complete medical exam to check for injuries. When an interrogator requested to screen detainee's personal effects prior to the interrogation, the MP guard would have the interrogator sign for the items. The interrogators used the same screening sites they use for interrogations to review personal effects. One MI Officer felt there was a doctrinal shortcoming pertaining to interrogation operations. He felt there should be a standing operating procedure (SOP) for the operations of a joint interrogation facility (JIF) that is standard Army wide. MP personnel provided the detainees with food, bottled water and access to medical treatment. The detainees slept in cells, received blankets and had access to latrines and showers.

OPERATION IRAQI FREEDOM

Based on interviews and sensing sessions with leaders and Soldiers in Continental United States (CONUS)/Outside CONUS (OCONUS) the DAIG Team found 50% (13 of 26) of interviewed point of capture company leaders stated that their companies had established and operated non-doctrinal company CPs in OIF. These companies detained individuals during their cordon and search operations and raids. The remaining 50% of interviewed point of capture company leaders transported their detainees to the next higher collecting point. The companies held anywhere from 3 to 15 detainees for a period of 12 hours up to 3 days. This was longer than the recommended doctrinal standard of 12 hours. Doctrine also has the MP operating CPs to temporarily secure EPWs /CIs until they can be evacuated to the next higher echelon's holding area. MP personnel are not doctrinally assigned at the company level to collect or guard detainees. The capturing unit had the responsibility to guard their detainees for extended periods of time, which took the Soldiers away from performing their combat mission and adversely impacted the combat effectiveness of the unit. The company CPs were established to interrogate detainees closer to the point of capture prior to evacuating the detainee to the next higher level CP. The unit completed the required detainee paperwork at this location. The required paperwork included 2 sworn statements, the Coalition Provisional Authority Forces Apprehension Form, and DD Form 2745, Enemy Prisoner of War Capture Tag. The unit had to complete this process in order to evacuate the detainees to the next higher location. Units inventoried and bagged the detainees' personal property as part of the paperwork process. Of the interviewed company leaders that had established the company CPs, 62% (16 of 26) said they would interrogate the detainee to gather information while holding them at the company CP. This tactical questioning (TQ) was more than just asking the detainee basic questions (name, age, place of residence, etc); it was an attempt to gather intelligence that might aid the unit in locating other potential targets. In a few cases, when available, units had THTs to conduct initial intelligence screening of detainees. Another 15% (4 of 26) of interviewed company leaders that had established the company CPs, asked detainees basic questions to complete the paperwork. The remaining 23% (6 of 26) of interviewed company leaders that had established the company CPs said they did not conduct interrogations or question detainees at all. The unit leadership did not have the proper training in interrogation procedures and techniques to conduct effective interrogations. Without training, individual conducting interrogation could possibly jeopardize vital intelligence information instead of quickly processing and transporting detainees to an area with trained interrogators. The company CP provided detainees with; food, bottled water, limited shelter and limited medical treatment. The unit transported detainees to the battalion CP during re-supply assets operations for unit security.

Of the interviewed combat arms brigade/battalion leaders who performed cordon and search missions and raids 77% (10 of 13), operated their own non-doctrinal battalion CPs. The remaining three interviewed battalion/brigade leaders said they did not operate CPs but would transport the detainee to the division forward CP. Battalions held 12 to 20 detainees at their CPs for 12 hours up to 14 days, relying on their subordinate units to guard the detainees for extended periods of time. This guard requirement took Soldiers away from performing their combat mission and adversely impacted the combat effectiveness of their units. MP personnel are not doctrinally assigned at the company level to collect or guard detainees. The battalions required capturing units to complete all mandatory paperwork (sworn statements, Coalition Provisional Authority Forces Apprehension Form, and DD Form 2745) before accepting the detainees into their battalion CP. The interviewed combat arms brigade/battalion leaders (77%, 10 of 13) said TQ or interrogations of detainees were performed to gather tactical information if there were no trained interrogators at their location. Battalion commanders and S2s did their own interrogations of detainees to ease the backlog of detainees at CPs. Of these battalion commanders 18% (1 of 13) said they had a THT team at their location to conduct interrogation of detainees and 15% (2 of 13) said they did not question detainees. There were not enough interrogators to be pushed down to battalion level to conduct interrogations of detainees. Without trained interrogators at the battalion level and below, the units risked missing intelligence information by holding detainees, instead of quickly processing and transporting them to an area with trained interrogators. The battalion CPs provided detainees with; food, water, shelter, blankets, latrines, and limited medical treatment. Battalions transported the detainees to the division forward CP during re-supply operations.

Based on interviews with leaders in OCONUS/CONUS who said they operated division forward CPs located in a brigade area, the DAIG Team found 45% (5 of 11) were operated by non-MP units during the period of May 03 to April 04. Another 27% (3 of 11) of division MP platoons operating CPs required augmentation from 4 to 14 Soldiers from Infantry units to help them with this mission. The remaining 27% (3 of 11) of CPs were operated by MP platoons. The forward CPs held between 4 to 150 (150 detainees in one incident) detainees from 24 hours up to 54 days. The MP platoon provided trained MP personnel to handle, safeguard, and account for detainees. This included reviewing the point of capture unit's paperwork for each detainee, assigning detainees an internally generated detainee number, and a complete inventory of each detainee's personal belongings on a DA Form 4137. The personal belongings were bagged with the DA Form 4137 to include a matched internally generated detainee number and secured in an evidence room, separate cell, small footlocker, container, or tent. If the unit delivering detainees to the forward CP did not have the required paperwork (sworn statements, Coalition Provisional Authority Forces Apprehension Form, and DD Form 2745), the in-processing personnel would not accept the detainee into the CP until the unit completed the paperwork. The paperwork, to include evidence the unit brought in with the detainee, was a critical source of useful information the interrogator could use during their interrogations. The brigades were using their MI interrogators and contracted interpreters to interrogate detainees and gather tactical intelligence information for their units. Personnel operating CPs had different procedures in place for transferring a detainee to an interrogator. If the detainee was not leaving the CP then the guard did not have the interrogator sign for the detainee. When the interrogator was finished with the detainee he would return the detainee to the guard who would then return the detainee to the cell. However, if a detainee was taken outside the CP then the interrogator would sign for the detainee on a DD Form 2708 or DD Form 629, Receipt for Prisoner or Detained Person. Upon the detainee's return, the guards would sign for the

detainee and the medic or guard would check the detainee for marks or bruises and then annotate the marks or bruises if any, on an SF 600, Medical Record - Chronological Record of Medical Care. The DAIG Team did a sampling of detainee records to include the SF 600 and the team found no annotations of marks or bruises. The detainees were provided; food, bottled water, shelter, blankets, latrines, and medical treatment. The unit transported detainees to the division central CPs by either ground (wheeled convoy) or air (CH-47 helicopter).

Two of 4 division central CPs were operated by a platoon from the division MP company, which required augmentation of 7 to 15 Soldiers from Infantry or Engineer units to help them with this mission. The remaining two division central CPs were operated by platoons from a different division or from a company from the MP battalion (Corps). MP platoons provided trained personnel to handle, safeguard, account for, and input information into the Detainee Reporting System (DRS) and or Biometric Automated Tool Set (BATS) system. This included a review of point of capture paperwork for each detainee and an inventory of their personal belongings on DA Form 4137. Once the inventory was complete the evidence custodian locked the detainee's personal property in a separate room. The central CPs used both MI interrogators and contract interrogators and interpreters to interrogate detainees. The MP guards did not have the interrogator sign for the detainee if the interrogator was not departing the CP. Division central CP SOP required the guards to have the interrogators sign a DD Form 629 or DD Form 2708, and enter the information on their DA Form 1594, Daily Staff Journal or Duty Officer's Log, if the detainee departed the CP. Three Provost Marshals said Other Government Agencies (OGAs) did interrogate detainees, however, this required their approval, and the OGAs had to sign for the detainee. Upon their return they were examined and resigned for to regain custody of the detainee. The division central CP held anywhere between 70 to 200 detainees from 72 hours up to 45 days. The division central CP provided the detainees with food, bottled water, shelter, blankets, latrines, and medical treatment. The division central CP transported detainees by ground convoys or helicopter to I/R facilities.

I/R facilities were operated and controlled by MP battalions, MP companies, and in lieu of units (non-MP units). MP personnel processed the detainees into their facilities, which included checking the detainees against the roster for arrival, obtaining weight and height, issuing an Internment Serial Number (ISN), medical screening, inventorying, and tagging property, and review of paperwork (sworn statement, Coalition Provisional Authority Forces Apprehension Form, completed DD Form 2745 verifying that detainee data was entered into the DRS system, and amending and updating the database information as required. The detainee's personal property was annotated on DA Form 4137 and placed in a bag or a box with the detainee's ISN number. The property was then placed in a controlled access evidence room. Each detainee was issued a blanket, jumpsuit, shoes, and a Qur-an as part of their in-processing.

There was no specific length of time I/R facilities held detainees. The I/R facilities held anywhere from 1700 detainees up to a maximum of 7000 detainees depending on the facility. Inside each I/R facility were a series of compounds housing from 450 to 700 detainees each. The operations of I/R facilities and compounds were the responsibility of the MP (Combat Support) battalions who were sometimes not properly equipped with specific items necessary for detainee operations and were not trained specifically on detainee tasks in order to perform this mission. Additionally, in lieu of (ILO) units assigned the guard force (tower) and escort mission for I/R facilities received limited MP training at their Mobilization Site.

Interrogators used the screening procedure to identify a detainee who may have intelligence information. The interrogators screened both the detainee paperwork along with his/her personal effects to determine which individual possessed intelligence information. When an interrogator requested to screen a detainee's personal effects prior to the interrogation, the MP guard would have him sign for the items using DA Form 4137. The MP guard escorted the detainee to the interrogators, and since the detainee was not leaving the facility the interrogator was not required to sign for the detainees. If the detainee was leaving the facility a written authorization was required, and the guard had the individual sign for the detainee on a DD Form 2708 or DD Form 629. The MI units used military and contract interrogators and interpreters to interrogate the detainees. MP personnel provided the detainees with food, water (bottled water or 5 gallon cans), and access to medical treatment. Each compound had shelter, mats or cots to sleep on, latrines, and showers.

(4) Root Cause: Division level units are not resourced with sufficient numbers of Military Police personnel and Military Intelligence personnel (interrogators) to conduct detainee operations in a non-linear battlespace. Point of capture units did not comply with doctrine that requires the quick evacuation of detainees to internment facilities. Units held detainees at CPs closer to the point of capture for longer periods of time to conduct more effective interrogation and intelligence exploitation so they could obtain time-sensitive tactical intelligence.

(5) Recommendation: TRADOC and G3 update the Military Police force structure at the division level and below to support the simultaneous execution of detainee operations and other battlefield missions.

Recommendation: TRADOC and G3 update the Military Intelligence force structure at the division level and below to integrate the requirement for detainee operations that allows for timely intelligence exploitation.

Recommendation: TRADOC update doctrine to integrate tactical interrogation at battalion and company level to assist in the intelligence exploitation of detainees immediately upon capture.

d. Finding 12:

(1) Finding: There was no Theater Detainee Reporting Center (TDRC) acting as the central, theater-level agency responsible for detainee accountability, resulting in a lack of detainee personnel and data management.

(2) Standard: See Appendix E.

(3) Inspection Results: The Office of the Provost Marshal General (OPMG) has redesignated the doctrinal term Prisoner of War Information Center (PWIC) used in the above standards as the TDRC, and the doctrinal term National Prisoner of War Information Center (NPWIC) as the National Detainee Reporting Center (NDRC). The following inspection results will refer to these organizations by their redesignated titles.

The DAIG Team found there was no central agency in theater to collect and manage detainee information for OPERATION ENDURING FREEDOM (OEF) or OPERATION IRAQI FREEDOM (OIF), and no consolidated, comprehensive, and accurate database for detainee

accountability. The TDRC that had the doctrinal mission to maintain detainee accountability was not deployed to OIF or OEF during the timeframe of the inspection. In OIF, the TDRC mission of detainee data collection was consolidated at one location in Iraq and was executed as an additional duty by a battalion S1 section. None of the major functions of the TDRC were performed in accordance with policy. Internment facilities were not fully accounting for detainees or property, and they were not meeting policy requirements. There were no procedures to ensure records on detainee disposition, health status, and personal/evidentiary property were adequately accounted for during movement of detainees between collecting points and internment facilities. Capturing units did not have standardized procedures for recording detainee personal and property information or for maintaining accountability. Doctrine and policy for detainee data collection need to be revised to address technological requirements for personnel accountability systems (biometrics) and the processing of non-compliant detainees in the current operating environment.

The TDRC is the specialized unit whose mission is to be the central agency in theater for total detainee and property accountability, from which consolidated detainee data is forwarded to the NDRC. There are two Reserve Component TDRCs, and no Active Component TDRCs, in the Army. TDRCs are structured as 59-Soldier units consisting of a headquarters detachment, operations, record keeping, property accountability, postal operations, public relations, information management, and other staff sections. TDRCs were not used in OIF or OEF. A TDRC was activated and deployed to Kuwait during the mobilization for OIF, but it did not move forward into Iraq in support of detainee operations and was re-deployed to Continental United States (CONUS). However, the large numbers of captured detainees, holding detainees longer for intelligence exploitation, and a slow release process resulted in a significantly higher detainee population and a demonstrated need for the TDRC.

In OIF, the TDRC mission of detainee data collection for Iraq was assigned to the MP battalion at Camp Bucca and overseen by the S1 as an additional duty. Detainee data was consolidated as it was received from locations throughout the country and forwarded to the NDRC. Forwarded data was often incomplete, and the S1 lacked the resources to track down missing data from reporting internment facilities. The TDRC responsibilities for detainee property accountability, tracking, records management, and postal operations were not met. The S1 performed as well as could be expected with limited organic assets, but it was impossible to execute the many mission requirements that would normally be executed by a 59-Soldier TDRC. A TDRC was not deployed in OEF. The internment facility at Bagram performed the mission of detainee data collection, consolidation, and reporting. Although information management and property accountability were more consistent in Afghanistan than in Iraq, most TDRC responsibilities were not being performed.

In the absence of a TDRC there were inefficiencies in accounting, reporting and tracking of detainee information from internment/resettlement facilities to the NDRC. The NDRC developed the automated Detainee Reporting System (DRS) as a standardized, automated data system that the TDRC uses to consolidate data from the internment facilities and forward to the NDRC. With no TDRC to provide oversight, OIF and OEF detainee processing centers often used simple spreadsheets or alternate automated data systems (Joint Automated Booking System (JABS) and Biometric Assessment Tool Set (BATS)) with the ability to capture biometric data (e.g., fingerprints), but these applications did not capture other data required by Army policy. Moreover, the alternate data systems were not compatible with DRS and could not transfer information to the NDRC. At the direction of the NDRC, the DRS became the primary

automated database that internment facilities were required to use. Concurrently, internment facilities continued to enter data in JABS and BATS due to the inability of DRS to record biometric data. (Note: The DRS is projected to have the capability to collect and store fingerprints by July 2004.) There is a fourth detainee reporting system in place to collect the same data in Arabic for use by the Coalition Provisional Authority (CPA). Because of the use of multiple data systems, incomplete data entry, and the inconsistent implementation of the DRS there are approximately 50,000 missing data points in the NDRC database.

Capturing units did not have standardized procedures for recording detainee personal and property information or for maintaining accountability. In OEF and OIF, units at points of capture and collecting points were not uniformly using DD Form 2745, Enemy Prisoner of War (EPW) Capture Tag. Of the assessed units in Iraq (19%) were using DD Form 2745, compared to 55% in Afghanistan and 30% of units redeploying from both theaters. In Iraq, the Coalition Provisional Authority Forces Apprehension Form was used, a form that is more comprehensive than the EPW Capture Tag. Although the CPA form appears better than DD Form 2745 for the purpose of intelligence exploitation and continued custody determinations, there was no TDRC in theater to manage the use of the form or capture information from the form for forwarding to the NDRC. Units did not uniformly forward documentation (medical, evidence/property, capture, and intelligence documents) when detainees were transferred to other echelons of detention. Furthermore, there was no mechanism during the transfer process to maintain accountability for records that accompanied a particular detainee.

The DAIG concluded the reason for the lack of accountability, standardization and reliability of detainee data is directly related to the absence of the TDRC. The sole purpose of the TDRC, as the field operating agency for the NDRC, is to ensure the accountability of detainees and their property by standardizing practices throughout the theater and implementing DoD and Army policy. An 8-person Camp Liaison Detachment (CLD) was deployed as part of OIF 2 to perform the functions of the TDRC, in addition to numerous other responsibilities. They have received initial training on the DRS, but as a CLD they are not trained on the procedures for executing the other specific TDRC tasks. The CLD may be able to accomplish the TRDC mission if appropriately trained and relieved of additional, unrelated duties, but they lack sufficient manpower to address the backlog of unaccounted-for detainees and property.

(4) Root Cause: The TDRC was not deployed for OEF. In OIF, it was initially deployed and subsequently redeployed without moving forward in the theater.

(5) Recommendation: CFLCC submit a Request For Forces for the Theater Detainee Reporting Center (TDRC) to meet the requirements for reporting and accountability of detainees and their property.

Recommendation: The Provost Marshal General review the TRDC process, structure, and employment methods for maintaining information on detainees, their property, and other related requirements within an assigned theater of operations and consider the development of an information technology solution.

e. Finding 13:

(1) **Finding:** The ongoing Military Intelligence Force Design Update is better suited to conduct simultaneous and sustained human intelligence missions in the current and future operating environment.

(2) **Standard:** See Appendix E.

(3) **Inspection Results:** The DAIG Team found the ongoing Military Intelligence - Counterintelligence/Human Intelligence Force Design Update is better suited than the current Military Intelligence force structure to conduct simultaneous and sustained human intelligence collection and counterintelligence/force protection missions in the current and future operating environments.

The current Military Intelligence (MI) force structure lacks the necessary 97E - Human Intelligence (HUMINT) Collectors (formerly called interrogators) and 97B - Counterintelligence personnel to conduct simultaneous and sustained HUMINT collection and counterintelligence/force protection missions. The current force structure does not allow the commander to employ the doctrinal concept of conducting both HUMINT and counterintelligence missions simultaneously. Currently the commander must choose which mission is the priority. These items are covered in the Current Military Intelligence Force Structure Section below.

The ongoing Military Intelligence - Counterintelligence/Human Intelligence (HUMINT) Force Design Update (FDU), provides the necessary 97E and 97B personnel to conduct simultaneous and sustained HUMINT collection and counterintelligence/force protection missions. Multiple MI initiatives and programs, specifically the Counterintelligence/HUMINT FDU, are reshaping the MI force structure in a multi-tiered approach, to include: increasing the 97E authorizations, converting 97Bs to 97Es, converting 97L (Translator/Interpreter) to 97E and 97B, rebalancing the Active Component (AC) to Reserve Component (RC) mix to move more personnel to the AC, increasing the number of MI units and the dispersion of Tactical Human Intelligence (HUMINT) Teams (THTs) in the division and Stryker Brigade force structures, and designing Human Intelligence (HUMINT) Collection Teams (HCTs) throughout the Unit of Action (UA), Unit of Employment x (UEX), and Unit of Employment y (UEy) level. These items are addressed in the Military Intelligence - Counterintelligence/Human Intelligence Force Design Update Section below.

CURRENT MI FORCE STRUCTURE

The MI mission to gain HUMINT information during detainee operations is performed by the 97E. In contrast, the 97B counters the intelligence gathering of foreign intelligence and security services (FIS). Gathering information from detainees focuses the 97Es on their specialty: gathering and developing intelligence from the local environment. The 97E10 is a highly trained Soldier who has gone through 82 weeks of training. This Soldier has completed language training from the Defense Language Institute, in addition to the required Military Occupational Specialty (MOS) training. Developing this asset is a costly and time-consuming process.

The current force structure does not give the commander on the ground the amount of 97E and 97B expertise required. A divisional MI battalion has all of the 97Es in the division (depending on the type of division, approximately 16 are authorized). The DAIG Team visited one division that had six 97Es. In the current operating environment people are the key terrain, but the force structure lacks 97Es and 97Bs at the brigade level.

The average maneuver brigade has an intelligence team consisting of four 97B - Counterintelligence personnel and three 97E - HUMINT personnel (approximately two Tactical HUMINT Teams (THTs)). These 97Es come from the division MI battalion. The commander must set the intelligence priorities at either HUMINT (gathering intelligence from the local environment and information exploitation from detainees) or at counterintelligence (denying FIS intelligence on U.S. Forces).

G3 Force Developers stated current rotations in OPERATION ENDURING FREEDOM (OEF) and OPERATION IRAQI FREEDOM (OIF) require approximately 130 THTs per deployment. There are approximately four personnel per team. The ongoing Counterintelligence/HUMINT Force Design Update has greatly contributed to meeting the current operational needs. Since 2001, the number of THTs has grown from 300 teams to 450 teams. Even with these changes, the current force structure lacks the depth to meet this doctrinal requirement for a sustained period.

There are usually three 97E HUMINT specialists in the current brigade force structure; they come from the division MI battalion. They gather intelligence on threat forces and capabilities. The 97Es, as part of THTs, accompany patrols, visit communities, talk to local leaders, to gather information on how U.S. Forces are being targeted. The 97Es evaluate the internment/resettlement (I/R) population to identify potential intelligence sources. They conduct interviews and interrogations across the range of detainees, gathering information from civilian internees, enemy prisoners of war (EPWs), and high-risk detainees (HRDs).

Information gathered from detainees is critical to meeting the doctrinal mission of the 97E "to conduct focused collection, analysis, and production on the adversary's composition, strength, dispositions, tactics, equipment, personnel, personalities, capabilities, and intentions". Exploitation of intelligence gathered from EPWs and HRDs is one of the reasons detainees are kept beyond the doctrinal time standard at the point of capture and brigade level. The current force structure of three 97Es in the brigade (division MI battalion assets) provides limited resources to evaluate, gather, and analyze information from detainees.

The 97B counterintelligence mission requires the intelligence assets of the brigade to cover a large section of the local population. The brigade has a total of 4 counterintelligence specialists who gather information on threat forces and foreign intelligence services and their activities and then develop force protection and information denial measures. The 97B focus on denying intelligence to the enemy is based on their ability to stop the following FIS operations: counter-HUMINT, counter-signals intelligence (C-SIGINT), and counter-imagery intelligence (C-IMINT). The 97Bs are not accomplishing their counterintelligence and force protection missions if they are supporting the HUMINT mission of gathering information from detainees.

The current force structure of the MI is a result of the 1997 Quadrennial Defense Review (QDR) process. The QDR reshaped tactical MI units, relying heavily on the Reserve Component (RC) to carry a large portion of MI personnel. Additionally, in 1994 and 1995, the

Army restructured personnel authorizations and sent 97E personnel to the Defense Intelligence Agency.

A substantial number of active component 97Es and 97Bs are in U.S. Army Intelligence and Security Command (INSCOM) Theater Intelligence Brigades (BDEs)/Groups (GPs). Until recently, those personnel were not available to support rotational sourcing.

Some commands were using 97Bs to fill 97E requirements to meet the shortage of personnel who can conduct interrogations of detainees. Commanders who chose the collection and exploitation of information as the priority mission gave up the 97Bs from performing their counterintelligence/force protection mission. However, force protection is still a critical issue due to the non-linear battlefield. Based on the current force structure, the Army has the ability to support either force protection or HUMINT.

Currently, 60% of the 97E and 97B force structure is in the Reserve Component (RC). Deployment of some units as battalions vs. teams in early rotations to OEF followed by OIF artificially reduced the available population to support subsequent rotations. The buildup of RC THTs prior to OIF met the immediate requirement for tactical intelligence but denied a sustained capability. Additionally, the MOS qualification rate in the RC is at 50%. So even if all RC authorized positions were filled, only one-half of the personnel would be deployable.

The TRADOC proponent (U.S. Army Intelligence Center and Fort Huachuca) developed the Military Intelligence - Counterintelligence/HUMINT Force Design Update and other initiatives to meet the requirements of the current and future operating environments. G3 Force Management is restructuring the force through redesign of current Modified Tables of Organization and Equipment (MTOEs) of MI units and creation of new MTOEs. The new force structure increases the authorizations for and distribution of 97E and 97B.

MI - COUNTERINTELLIGENCE/HUMAN INTELLIGENCE FORCE DESIGN UPDATE

The Army recognizes the current force structure does not allow the commander to conduct the doctrinal missions of HUMINT and counterintelligence simultaneously. Currently, the commander must choose which mission is the priority. The Counterintelligence/HUMINT FDU was approved on 2 August 2001. Some aspects of the Counterintelligence/HUMINT FDU and other MI initiatives and programs have assisted the force in current operations, while the majority is still ongoing (as of 21 May 2004). The number of THTs in the Army has increased by 50% since 2001 (300 THTs to 450 THTs).

The main portions of the Counterintelligence/HUMINT FDU will occur from 2005 to 2009 Total Army Analysis 09 (TAA 09); additional changes will continue in 2007 through 2011 (TAA 11). The changes to the force structure are being documented in the UA, UEx, UEy, templates and in the Stryker Brigades' Modified Tables of Organization and Equipment.

The near-term changes include adding one counterintelligence company per Theater at Echelon Above Corps Theater Intelligence Groups/Brigades in Fiscal Year (FY) 05-07. The FDU and other initiatives add a variety of active component Counterintelligence/HUMINT Teams to Theater Intelligence Groups/Brigades for an increase of 400 counterintelligence/HUMINT spaces in FY06. Other changes include revising the MI Corps Support BN (MI-CSB) and changing the MI-CSB allocation from one MI-CSB per Theater to one MI-CSB per Corps.

Another Corps-level change is the creation of a "Corps G2X Cell" in the G2 section of the HHC with HUMINT authorizations.

Four counterintelligence and 2 HUMINT companies (U.S. Army Reserve) will activate in FY05-07. Finally, the AC/RC mix will rebalance, resulting in activation of 2 HUMINT companies and 1 counterintelligence company (active component) and deactivation of 2 U.S. Army Reserve counterintelligence companies.

The design of the HUMINT team will change. Previously, Warrant Officers led HUMINT teams; in the future a Sergeant First Class will lead some HUMINT teams. The current force structure can convert to an enlisted-led team by using currently available NCOs.

The Counterintelligence/HUMINT FDU is programmed to increase the number of 97E and 97B Soldiers; 97E will increase by 50%. An increase of "in excess of" 1400 97E and 97B personnel is programmed from FY05-07, including an increase in authorizations for 97E and 97B in the AC. Some of these changes will be the result of rebalancing the AC/RC mix of 97E. The 97E personnel increases have been implemented early and continue to occur. Other changes include the conversion of 460 Compo 2 MOS 97L (Translator/Interpreter) to 97E and 97B authorizations in FY05.

MI Branch will restructure the 97E MOS. 97E10 Soldiers will no longer have a language requirement following initial entry training (IET). By removing the language requirement at Skill Level 1 for 97E MOS the MI branch can send 97E10 Soldiers directly to units to gain experience. The language requirement will shift to a 97E20 requirement. Currently the 97E10 Soldier spends up to 82 weeks post-IET meeting the language requirement.

The Counterintelligence/HUMINT FDU and other initiatives will support the design of elements within the UEy, UEx, and UA. (The current design of the UEy, UEx, and UA are the base for this section of the report). This increase of counterintelligence/HUMINT units at each level is significant and is designed to add an intelligence gathering and processing capability at the UA level, as well as at higher levels. The Army's ability to add counterintelligence/HUMINT resources as it transforms into the Modular Design is based on an increase in the number of 97Es authorizations, which go from the FY04 level of 861 authorizations to the FY 11 projection of 3312 authorizations.

The UEy's Theater Intelligence Brigade will add an Exploitation Battalion and a RC Battalion that are in-Theater assets. The Exploitation Battalion and the RC Battalion will each add a counterintelligence company and a HUMINT company to the Theater, providing an additional 2 counterintelligence companies and 2 HUMINT companies to the commander.

The UEx has a G2X cell designed into its Main HQ staff. The G2X is a new organization not in the current division template. The G2X acts as the single point for all counterintelligence/HUMINT data. The G2X is a 6-person team led by an officer (MAJ/CPT) and contains a CW3 HUMINT Technician, one 97B, and three 97Es. Supplying information to the G2X are the Counterintelligence Control Authority (CICA) and the HUMINT Operations Cell (HOC). The CICA provides the counterintelligence function with 97Bs while the HOC adds 4 more 97Es for the HUMINT function. The G2X also contains a Language Coordination Section which sets up contracts for interpreters. The main HUMINT and counterintelligence gathering capability will exist in the UAs.

There are HUMINT and counterintelligence gathering capability in both Maneuver UAs (MUA) and Reconnaissance, Surveillance, and Target Acquisition UAs (RSTA UA). In the MUA and the RSTA UA the main HUMINT collection will be conducted by the HUMINT Collection Teams (HCTs) which have taken the place of the Tactical HUMINT Teams (THTs). The HCT is made up of four 97E whose mission is to gather HUMINT. This will eliminate the THTs' requirement of dividing the time among the mission of the 97B and the 97E that made up the THT. The THT currently exists in the division force structure and the Stryker Brigade force structure; THTs are not in the UA or UE force structures.

Each MUA has an S2X in the headquarters, serving the same function as the G2X does at the UEX. The MUA also has an MI company with a robust intelligence gathering capability. The HUMINT platoon contains 26 Soldiers focused on gathering HUMINT. The HUMINT platoon has two Operations Management Teams (OMTs) that each manages two HCT. Each OMT also has the ability to serve as a HCT. At the minimum, each MUA has an organic capability to field four HCTs and, if needed, generate 2 more from the OMTs. This gives the UA commander the ability to put HCTs at the point of capture or where detainees are first encountered.

The RSTA UA has a greater HUMINT capability. The MI battalion in the RTSA UA has a Collection and Exploitation (C&E) company and a counterintelligence/HUMINT company. The C&E Company has 3 HCT platoons (28 Soldiers per platoon) with 1 OMT and 5 HCTs per platoon. The C&E Company has a total of 15 HCTs. The counterintelligence/HUMINT company has 9 OMTs and 27 HCTs. At the minimum, each RSTA UA will have 42 HCTs on the ground.

The significant difference from the current division force structure is that the average division has all 16 Soldiers with MOS 97E in the division MI battalion. The UEX will deploy into theater with a modular capability that is based on the mission requirements. If the UEX deploys with 4 MUAs and a RSTA UA, it will have a total of 20 OMTs and 58 HCTs and a robust HUMINT planning, coordination, and analysis capability.

(4) Recommendation: TRADOC and G3 continue to refine and implement the force structure changes in the Military Intelligence - Counterintelligence/Human Intelligence Force Design Update.

Recommendation: TRADOC integrate the Military Intelligence - Counterintelligence/Human Intelligence Force Design Updates into the development of Units of Action and Units of Employment.

f. Finding 14:

(1) Finding: The ongoing Military Police Force Design Update provides a force structure for internment/resettlement operations that has the flexibility and is better suited to conduct sustained detainee operations in the current and future operating environment.

(2) Standard: See Appendix E.

(3) Inspection Results: The DAIG Team found the ongoing Military Police - Internment/Resettlement Battalion Force Design Update provides a force structure for Military Police internment/resettlement operations that has the flexibility and is better suited than the current Military Police force structure to conduct sustained detainee operations in the current and future operating environments, to include control and internment of high-risk detainees.

The current Military Police force structure lacks the 31E (Internment/Resettlement Specialist) personnel to meet the requirements of manning the current detention facilities and conducting sustained detainee operations in the current and future operating environments, to include control and confinement of high-risk detainees. The 31E is the only Soldier trained to run a detention facility and specifically deals with controlling and confining high value detainees. The Active Component (AC) 31Es are in the Table of Distribution and Allowance (TDA) that runs the U.S. Military Disciplinary Barracks (USDB), staffs Guantanamo Bay Naval Station (GTMO) and other outside the continental United States (OCONUS)-based confinement facilities, and staffs continental United States (CONUS)-based confinement facilities. The Reserve Component (RC) does not have the 31E personnel to provide units to run sustained detainee operations. These items are covered in the Current Military Police Force Structure Section below:

The ongoing Military Police Internment/Resettlement (I/R) Battalion Force Design Update (FDU) standardizes the force structure of Active Component (AC) and Reserve Component (RC) I/R units, converts AC Tables of Distribution and Allowance (TDAs) to I/R Modified Tables of Organization and Equipment (MTOEs), and increases personnel and units throughout the AC and RC force structure. The FDU was approved September 2003, this analysis is based on that data and is current as of 21 May 2004. The increase of deployable 31Es will give Combatant Commanders the flexibility to conduct sustained detainee operations in a non-linear battlefield and the ability to control and confine high-risk detainees (HRDs). The I/R FDU provides the RC force structure necessary to carry out its sustainability mission. Employment of the I/R FDU has been incorporated into the Unit of Employment (UE) design at Unit of Employment y (UEy) level with staff support at Unit of Employment x (UEx) level. These items are covered in the Military Police Internment/Resettlement (I/R) Battalion Force Design Update Section below:

CURRENT MP FORCE STRUCTURE

The current AC TDA organizations, such as the U.S. Army Disciplinary Barracks (USDB) and Regional Correctional Facilities (RCFs) are not deployable, and each has a different force structure. Each facility will convert to at least one I/R company.

The AC 31E population is based out of 4 installations within CONUS TDA units and 2 Modified Table of Organization and Equipment (MTOE) MP battalions that are OCONUS. In CONUS, the largest population of 31Es is at the USDB at Fort Leavenworth. Large numbers of 31Es are also assigned to the 3 Regional Correctional Facilities (RCFs) at Fort Lewis, Fort Sill, and Fort Knox. These are TDA organizations and not designed to deploy, lacking a rotational base to support the TDA corrections mission and other missions such as GTMO. There are 824 AC MOS 31E authorizations in the Army; of these, 770 are directly related to running the current detention facilities. There are 371 31E authorizations at the USDB. The other 31E authorizations are at Fort Lewis (112), Fort Sill (81), Fort Knox (80), and 24 at Navy/Marine facilities (CONUS and OCONUS). The 2 OCONUS MP battalions contain 31Es in their MTOE,

but lack the depth to support rotations; USAREUR has 76 authorizations and USFK has 26 authorizations. The remaining 54 are not directly working with U.S. prisoners or detainees. These Soldiers are at the U.S. Army Military Police School (24), recruiting (12), AC/RC support (6), and 12 others throughout the AC force.

The deployable 31Es are in the RC. The RC has 119 31E authorizations, 90 of which were filled as of 22 April 2004. The RC internment/resettlement (I/R) units' missions are to deploy or provide backfill for the AC's 31Es that deploy. However, the RC I/R units lack the qualified personnel to sustain the mission. Additionally, the RC has the only I/R command and control elements, two I/R brigades.

This force structure does not support the policy or doctrine requirement for a deployable, sustainable, and standardized, modular MP I/R battalion force design package that can meet the I/R operations objective of processing, handling, caring for, accounting for, and securing EPWs, CIs, RPs, ODs, DCs, and U.S. Armed Forces prisoners, as well as supporting the global war on terrorism (GWOT) and controlling and confining high-risk detainees. The I/R doctrine is a revision of the old Enemy Prisoner of War concept, reminiscent of Cold War doctrine applicable to a unit that is modular, capabilities-based, and deployable.

The new I/R doctrine adapts well to the Units of Action concept, however, the 31E force structure does not support I/R doctrine. FM 3-19.40, Military Police Internment/Resettlement Operations, 1 August 2001, covers most detainee operations, but at the time the doctrine was written, the MP Corps had not yet developed or defined the term high-risk detainee.

FM 3-19.1 Military Police Operations, Change-1, 31 January 2002, and FM 3-19.40, refer to the MPs as having the responsibility for coordinating sustainment for EPW/CI and that I/R battalions are equipped and trained to handle the EPW/CI mission for the long term. This is not true under the current force structure. By doctrine, an I/R battalion should support up to 4,000 EPWs/CIs, 8000 dislocated civilians, or 1500 U.S. Armed Forces prisoners. This formula does not address confinement of high-risk detainees. The current MP doctrine only focuses on long-term confinement of U.S. Armed Forces personnel.

The 31E Soldier receives his/her MOS training as part of Military Police Advanced Individual Training (AIT). All MP AIT is based on 31B (Military Police) training. There is a split in the MP AIT where 31Es and 31Bs go to different tracks. MOS 31E Soldiers take a 4-week Corrections track while the 31B receive 4 weeks of Law and Order training. The 31B (Military Police) do not receive corrections training. 31Bs receive one day of I/R training in MP AIT. The 31E10 gains MOS experience at a correctional facility or the USDB.

The current Military Police force structure is not designed to support Units of Action. The TDA-based AC units are not flexible, adaptable, or deployable.

The U.S. Army Training and Doctrine Command (TRADOC) proponent (U.S. Army Military Police School) developed an I/R Battalion Force Design Update and which was approved September 2003. G3 Force Management is restructuring the force through redesign of current MTOEs of AC and RC MP units and creation of new MTOEs. The new force structure increases the number of I/R units and 31E authorizations and is covered in the next section of this finding.

MP I/R BATTALION FORCE DESIGN UPDATE SECTION

The ongoing Military Police Internment/Resettlement (I/R) Battalion Force Design Update addresses the flexibility and sustainability of the current MP force structure. The current AC TDA organizations, such as the U.S. Army Disciplinary Barracks (USDB) and Regional Correctional Facilities (RCFs) are not deployable, and each has a different force structure. Each facility will convert to at least one I/R company.

The Director of Force Management approved the I/R Tables of Organization and Equipment (TOEs) on 17 May 2004. The I/R FDU will occur from Fiscal Year (FY04) through FY11. The FDU will standardize the I/R force structures in the AC and RC. The distribution of personnel and units will rebalance between the AC and RC, giving the AC the ability to immediately deploy I/R companies. The RC will have the force structure to accomplish the mission of backfilling Army confinement facilities as well as providing a sustained rotation of deployable units.

The I/R FDU will standardize the force structure and increase the MOS 31E expertise within the units conducting the I/R mission. The I/R battalion will be modular in nature, providing a command and control capability that is flexible and tailorable, that by design supports the Units of Action concept. The MP I/R battalion will be a flexible base that can be tailored to the Theater of Operations and the operating environment.

The I/R battalion Headquarters and Headquarters Detachment (HHD) is a 74-person unit that provides the command and control function and supports a mix of I/R companies, guard companies, and I/R detachments as required. A standard I/R battalion template for deployment could include the battalion HHD, 1 guard company, 1 I/R company, and 3 I/R detachments.

The I/R company is tailored around accomplishing the 31E mission and is the base of the new force structure. It can operate independently or as part of an I/R battalion. The I/R company will have 124 personnel, with 100 31Es. It has the built-in administrative support to conduct detainee operations as well as 2 internment platoons and a Maximum Security Section. The internment platoons each contain 42 personnel while the Maximum Security Section has 12 personnel. The Maximum Security Section is different from an I/R detachment. The I/R company should have the ability in the short term to control and intern HRDs, a capability that is essential in the current operating environment.

The I/R company can either operate as a stand-alone organization or operate as part of an I/R battalion. In either mission it provides command and control, staff planning, administration and logistical services (for both assigned personnel and the prisoner population). If the I/R company operates as a stand-alone unit, it is limited in the detainee operations functions it can perform. The stand-alone I/R company can operate either a U.S. Armed Forces prisoner confinement facility or a high-risk detainee internment facility.

If the I/R company operates as part of an I/R battalion, it can conduct a wider range of detainee operations due to the support of the I/R battalion's guard company and I/R detachments. When the I/R company operates as part of I/R battalion, it can operate the following types of facilities: high-risk detainee internment facilities; Enemy Prisoner of War/Civilian Internee (EPW/CI) internment facilities; or displaced civilian (DC) resettlement facilities.

The I/R company and I/R battalion force structures are focused on the I/R mission. Any I/R unit will require support from the Command it falls under. I/R units will require engineer support to build facilities, medical support for Soldiers and detainees, maintenance support, water purification, and other support as required.

The I/R company's main focus is supporting its 2 internment platoons and 1 Maximum Security Section. The I/R company has different capabilities based on whether it is conducting stand-alone operations or operating as part of an I/R battalion. If operating in the stand-alone function the I/R company has the capability to confine up to 300 U.S. prisoners or detain up to 100 high-risk detainees. If the I/R company is operating as part of an I/R battalion, the I/R company has the capability to detain up to 300 high-risk detainees when supported by 1 MP guard company. The I/R company also has the capability to conduct detainee operations for enemy prisoners of war/civilian internees or resettlement operations for dislocated civilians. In these detainee operations, the I/R company will also require support from one MP guard company.

The Maximum Security Section in the I/R company is responsible for detainees/prisoners who require special supervision, control, and discipline. These detainees/prisoners require close and intense management, special precautions, and more stringent confinement, search, and handling measures. The Maximum Security Section is merged with the internment platoons when conducting high-risk detainee operations.

The MP guard company has personnel and equipment resources to provide a perimeter security function as well as a transportation function. Each guard company has 3 platoons of 31Bs. Each platoon has four 11-man squads. The MP guard company has 3 light medium tactical vehicle (LMTV) trucks and 16 high mobility multipurpose wheeled vehicle (HMMWV) trucks authorized. This robust guard force and transportation assets will give the I/R battalion the capability to control and transport detainees using internal resources.

The I/R detachment is a 24-person unit that exists only in the RC. The I/R detachment augments an AC or RC I/R battalion HHD. There are no 31Es in an I/R detachment; the detachments support the detainee operations mission by providing 31Bs to act as outside-the-wire security and additional support personnel. The I/R detachment is not designed to detain HRD or U.S. prisoners. The 60 I/R detachments allow a high degree of flexibility in modularizing any organization for a mission. These units are designed to be mobilized and attached to other units as needed.

To meet the requirement for the I/R FDU, G3 plans to increase 31E authorizations through conversion of some 31Bs (Military Police) to 31Es (Internment/Resettlement Specialist), increased recruiting for 31E positions, and a redesignation of RC units to the 31E mission.

The conversion of Active Component MP TDA organizations to an I/R company MTOE has begun. The first AC I/R company will activate in FY04 at Guantanamo Bay (GTMO). A total of 10 AC I/R companies will activate by FY11.

The RC will contain the bulk of the 31E units and personnel. The RC currently contains 119 authorizations. When the I/R battalion FDU is completed in FY11, the RC will contain approximately 1720 31E authorizations, a 14-fold increase in personnel.

The U.S. Army Reserve (USAR) will contain most of the I/R battalions, while the Army National Guard (ARNG) will contain most of the I/R companies. By FY11, the RC will be organized with 20 I/R battalions (17 USAR, 3 ARNG) compared to the AC's 1 I/R battalion. The RC will have 17 I/R companies (7 USAR, 10 ARNG) compared to the AC's 10 I/R companies. The RC will contain all 60 I/R detachments (51 USAR, 9 ARNG). The I/R sustainment mission will be supplemented by this RC build-up of 17 I/R companies and 60 I/R detachments.

Based on the currently proposed MTOE, the standard I/R battalion will deploy with a battalion HHD, 1 guard company, 1 I/R company, and 3 I/R detachments. The template for a deployed I/R battalion will contain 427 personnel; 101 of them will be 31Es. The I/R company contains the 31E personnel in the 2 I/R platoons and the Maximum Security Section. The I/R FDU units contain the following personnel:

- I/R battalion HHDs: 74 total personnel (one 31E)
- I/R companies: 124 total personnel (100 31Es)
- I/R platoons: 42 total personnel (41 31Es)
- Maximum Security Sections: 12 total personnel (12 31Es)
- MP guard companies: 157 total personnel (no 31Es)
- I/R detachments (RC only): 24 total personnel (no 31Es)

The I/R FDU is designed to provide I/R units to the UEy that meet the specific requirements of the commander. The primary employment of 31Es will be at the UEy level. They will deploy in the I/R configuration best suited to the mission, whether it be as I/R brigades or I/R battalions. Current planning calls for two 31E NCOs (E-7s) working on the UEx staff, one in the UEx Main and one in the UEx TAC. Both will act as liaisons to the UEy I/R units and as advisors on I/R capabilities at the UEx level. There are no current plans to place 31Es in the Unit of Action (UA) or Stryker Brigades.

A UA will contain a 41-person MP platoon (31Bs). There will be no 31Bs in the Stryker Brigades. In the UEx and UEy, the 31Bs outside of the I/R units will not be primarily tasked with I/R operations.

(4) Recommendation: TRADOC and G3 continue to refine and implement the force structure changes in the Military Police - Internment/Resettlement Battalion Force Design Update.

Recommendation: TRADOC integrate the Military Police - Internment/Resettlement Battalion Force Design Update into the development of Units of Action and Units of Employment.

g. Finding 15:

(1) Finding: Three of 4 inspected internment/resettlement facilities and many of the collecting points, had inadequate force protection measures, Soldier working conditions, detainee living conditions, and did not meet the minimum preventive medicine and medical treatment requirements.

(2) Standard: See Appendix E.

(3) Inspection Results: The DAIG Team inspected 4 internment/resettlement (I/R) facilities and 12 forward and central collecting points (CPs). Three of 4 inspected internment/resettlement (I/R) facilities, and 3 of 12 (25%) inspected collecting points (CPs), had problems and shortcomings with deteriorating infrastructure that impacted on having a clean, safe, and secure working environment for Soldiers and living conditions for detainees. Poor food quality and food distribution, lack of laundry capability, and lack of personal hygiene facilities at some of these facilities affected the detainees' living conditions. Overcrowding, safety hazards, frequent enemy hostile fire, and lack of in-depth force protection measures also put both Soldier and detainee at risk.

Four of 16 (25%) inspected facilities (Camp Bucca, Bagram, Abu Ghraib, and Brassfield-Mora) were found to have safety hazards that posed risks to Soldiers and detainees. In addition, there was little evidence that units operating facilities had safety inspection programs in place. Safety programs in just a few facilities amounted to nothing more than detainee fire evacuation plans, weapons clearing procedures, and military working dog safety considerations. At the time of the inspection, Camp Cropper, Camp Bucca, and Abu Ghraib did not have finalized and approved Standing Operating Procedures (SOPs) for their facilities. At the time, units were busy revising and tailoring their SOPs for the mission. However, during SOP reviews conducted by the DAIG Team, there was no evidence that the risk management process was being incorporated into the working draft SOPs as required. Reviews of finalized SOPs at other facilities yielded the same results as the working drafts—no risk management was incorporated into SOPs.

No units fully complied with the medical treatment of detainees or with the sanitary conditions of the detainee facilities. Not all medical personnel supporting division CPs and I/R facilities were aware of detainee medical treatment requirements or had the proper equipment to treat a detainee population. The medical personnel interviewed stated that they did not receive any specific training in detainee operations and were not aware of Army Regulation (AR) 190-8, Enemy Prisoners of War, Retained Personnel, Civilian Internees and Other Detainees, 1 October 1997, although most believed they were required to treat detainees to the same standard of care as Coalition Forces. There was a widespread lack of preventive medicine staffing, supplies, and equipment to meet the needs of CPs and I/R facilities. This shortfall was compounded by the failure of units to deploy appropriately trained and supplied field sanitation teams. Medical leaders responsible for direct oversight of preventive medicine personnel lacked specific training in detainee operations and field sanitation. I/R facility site selection, design and construction decisions did not incorporate preventive medicine considerations. There was significant variance in the hygiene and sanitation conditions at CPs and in I/R facilities throughout Afghanistan and Iraq. While major improvements continue to upgrade conditions at most sites, the process has been hampered by shortages of preventive medicine personnel and materiel, problems with site selection and design, and detainee populations that exceed the current system capacity. Lack of trained preventive medicine personnel and required field sanitation supplies has contributed significantly to deficiencies in hygiene and sanitation at CPs and I/R facilities.

CAMP BUCCA

Soon after the ground conflict began in Iraq, the Camp Bucca I/R facility was designed and established as an internment facility for Enemy Prisoners of War (EPWs). At the time of the

DAIG inspection, Camp Bucca was considered an overflow I/R facility for Abu Ghraib, and all detainees were kept in the old facility, which contained 6 compounds. The new facility, containing six additional compounds, was in the final stages of completion. The old facility housed a non-compliant Civilian Internee (CI) population, third-country nationals, and a very small number of EPWs. Detainees were not segregated according to category (i.e., EPWs and CIs (to include Security Internees) were housed together in compounds 7 through 11). Compound 12 housed the third-country nationals.

The DAIG Team found inadequate security measures at the Camp Bucca. Camp Bucca had 2 controlled entry points leading into the compound, but blind spots along the perimeter made access possible at other points. The facility had a sally port gate, but it was used as a serpentine instead of a true double-gate security mechanism to control the entrance and exit of personnel and vehicles. The perimeter security consisted of roving guards, a gate guard, and a guard in each of the towers. There were 2 vehicular security patrols, but they would consistently take the same route, making them vulnerable to enemy attacks and Improvised Explosive Devices (IEDs) placed on the patrol route. The visitation process at Camp Bucca presented security concerns. During visitation hours Iraqi family members were searched at the exterior entry point, but thereafter they were allowed to mingle around guards who were carrying weapons until they were taken inside the compound to visit detained relatives. This posed a major security concern should one or more of the visitors overtake a guard and seize his weapon.

In numerous places at the old facility, the triple-standard concertina wire was over-stretched and not tied down properly, and the short and long U-shaped pickets were not spaced properly. This, and the fact that the detainees vastly outnumbered the guard force, posed a security concern and potentially put Soldiers at risk if detainees rushed the wire. There were 8 perimeter towers that were not mutually supporting, creating dead space and blind spots throughout the old compounds. The towers also did not have effective communications with the roving guards. The facility had good lighting according to leaders and Soldiers due to recently receiving 32 trailer-mounted portable light stands that can be moved around the facility as needed. The acquired light stands significantly improved the lighting around the compounds. At the time of the Taguba Investigation, the perimeter lighting around Camp Bucca was inadequate and needed to be improved to illuminate dark areas that routinely became avenues of escape. Many of the security concerns due to the wire fences were corrected when the detainees were transferred to the 6 new compounds that have been constructed. The chain link fence at the new compounds was not staked to the ground between fence posts to prevent detainees from slipping through the bottom. However, to overcome this shortcoming, the battalion was placing concertina wire around the inside perimeter of the chain-link fence. This is a significant improvement in security over the old compounds. Detainees were transferred to the new compounds after the DAIG visit. These safety and security concerns were resolved once the detainees were transferred and the old compounds phased out.

According to interviews and sensing sessions at Camp Bucca, Soldiers said food is distributed and served in 30 gallon plastic containers, sometimes long after it is prepared. Detainees served themselves by dipping whatever containers they possessed into the food. No utensils were provided, and no portion control measures were in place to ensure that each detainee got the proper amount of food. One leader interviewed stated that serving ladles were on order, but none were on-hand. Food frequently ran out before all detainees had an opportunity to eat. Soldiers stated in sensing sessions that Meals, Ready to Eat (MREs) had to

be used to ensure all detainees were fed. The detainees got their drinking water from water spigots at Camp Bucca. It was noted during the walk-through that at least one water source at one of the compounds was located several feet from the human waste dump (septic tank). This problem was eliminated once the detainees were transferred.

There was no laundry service at Camp Bucca to support the detainees so they did their own laundry with the small tubs and soap given them. However, leaders and Soldiers said during interviews that they did not know if there were enough washtubs supplied to the detainees. They were not sure how many detainees actually possessed tubs and soap, and where the tubs were located within the 6 compounds.

Camp Bucca did not routinely receive hostile fire, if at all. However, the compounds did not have adequate force protection measures in place to ensure the safety and protection of detainees and Soldiers from potential hostile indirect and small arms fire. There were no bunkers or shelters constructed with overhead cover for detainees to enter if the compounds came under attack. There were also no such bunkers or shelters constructed in the new compounds where the detainees are scheduled to be transferred.

The Taguba Investigation mentioned Camp Bucca as significantly over its intended maximum capacity, with a guard force that is under-manned and under-resourced. The DAIG Team found that Camp Bucca was not overcrowded nor under-manned because the facility had been scheduled to be discontinued as an I/R facility, and a drawdown in the detainee population had occurred after the investigation was conducted. A decision to use it as an overflow facility for Abu Ghraib kept it operational. The detainee population during the DAIG Inspection was 1769. Capacity for the newly constructed facility is 4500 according to the command briefing given to the DAIG Team.

BAGRAM I/R FACILITY

The Bagram I/R facility was designed and used as a Soviet aircraft maintenance facility that was built in the early 1960s. The DAIG Team found several safety hazards at the facility that posed risks to both Soldiers and detainees. Based on the document review and a thorough walk-through of the Bagram I/R facility, there was little evidence of a unit safety program. However, extensive engineering and environmental surveys of the facility, to include contaminated rooms and roof failures, had been recently conducted. At the time of the DAIG inspection, the infrastructure to support the facility was inadequate. Examples included inadequate ventilation/climate control and lighting on the main floor, the electrical distribution system throughout the facility, and non-existent sanitary facilities at the main floor.

In the Bagram I/R facility, there were no handrails and banisters on many of the steep stairwells and landings. The DAIG Team determined this was particularly dangerous while Soldiers escorted blindfolded detainees up and down the stairs. Team members actually witnessed Soldiers escorting blindfolded detainees on these stairs. Some drop-offs from the second floor landings were 5 to 7 feet.

Potential shock hazards existed at the Bagram I/R facility. There were numerous examples of open and exposed electrical wiring around the facility, to include a major electrical panel located in the vicinity of a known roof leak. Throughout the office areas, uncovered receptacles and light switches were found.

Contaminated soil (evidence of heavy metals) was found in the former metal plating rooms. The rooms were previously used as a metal plating facility as part of the Soviet aircraft maintenance facility. The unit requested and received an environmental survey of the rooms, and the conclusion was that the sampled materials represented a health risk. A rough cost estimate (\$3-6 million) to remediate the contaminated rooms was cost-prohibitive, and the decision was made to seal the rooms to protect Soldiers and detainees from exposure.

According to an interview, lead-based paint was procured from the local economy to paint the interior in various locations in the facility. Lead-based paint had been used in the past and was still being used in the Bagram I/R facility, creating a potential risk to Soldiers and detainees.

Concerning the non-existing sanitary system, Soldiers were required to remove modified portable latrines from each detainee group cell by hand. These latrines were dragged to a designated location outside the facility where contractors would empty and clean them. After cleaning the latrines, Soldiers dragged the latrines back into place in each detainee cell. During interviews and sensing sessions, Soldiers stated that human waste spills were frequent on the main floor. There was a project ongoing that will remedy this problem. The project included an installed indoor septic system that consisted of a 4-inch main line running underneath the newly poured concrete pads and along the length of the group cells. Toilets were being installed inside of each cell, and the effluent will flow via gravity to an exterior waste system. The estimated completion date was April or May 2004.

The facility had multiple roof leaks, to include an area that was repaired after damage from aerial bombing. In December 2003, the engineer group conducted a roof inspection and found possible obstructed roof drains and deterioration of parapet walls and flashing. The estimated cost to repair the roof is \$350K. This project was not funded at the time of the inspection.

At the time of this inspection, the facility had inadequate personal hygiene facilities for the number of detainees. An ongoing indoor plumbing system project to fix the problem will consist of a newly built shower room with full shower capabilities (10 shower heads) as well as a white water supply system. The fresh water supply will be housed inside of an exterior water system building that must also be designed and built.

The electrical distribution system in place was inadequate, especially to support planned upgrades for the facility that include lighting for new cells and towers and power for the Morale, Welfare, and Recreation room for the Soldiers. Current electrical amperage draw is 1279.7 amps. Amperage draw, once the upgrades are complete, will increase by another 340 amps, beyond the current transformer's capability of 1441 amps. The facility engineer was assessing the electrical load and prioritizing electrical distribution throughout the facility, with office air conditioning units and hot water heaters being shut down first during overloads to the system. There was concern that serious overloads to the system will occur this summer. There is a project planned to replace the transformer and renovate the electrical distribution system for the facility, but at the time of the inspection the project had not been funded.

ABU GHRAIB

Abu Ghraib had problems with deteriorating infrastructure that impacted the clean, safe, and secure working environment for Soldiers and living conditions for detainees. Poor food quality and food distribution, lack of laundry capability, and inadequate personal hygiene facilities affected the detainees' living conditions. Overcrowding, frequent enemy hostile fire, and lack of in-depth force protection measures also put Soldiers and detainees at risk. There is a separate finding concerning Abu Ghraib. See Finding 3 in Chapter 3.

COLLECTING POINTS

Detainees were being held at division forward and central CPs from 1 to 54 days for intelligence exploitation before release or transfer based on interviews and sensing sessions of leaders and Soldiers. If detainees are kept longer than doctrinally recommended, then the infrastructure standards for the facilities should be similar to I/R facilities for the security, safety, and wellbeing of the detainee. 3 of the 12 (25%) forward and central CPs inspected (Green Zone in Baghdad, Brassfield-Mora in Samarra, and Khost, Afghanistan) were determined to be inadequate to keep detainees for longer than doctrinally recommended due to not having the needed laundry services, personal hygiene facilities, medical care, and adequate shelter from adverse weather conditions and the elements. The division forward collecting point (CP) at Brassfield-Mora was also located within 100 feet of an ammunition holding area and fuel point. Enemy hostile fire targeting these areas could result in detainee casualties due to the close proximity of these sites to the collecting point. There were plans to fix a majority of these shortcomings at these three facilities.

Many forward and central facilities visited had recent improvements and upgrades made to them because of the inadequate facilities and harsh conditions. These improvements included upgrades to supporting infrastructure and expansions to facilities to relieve overcrowding, enhance security, and to provide for better sanitation conditions. Improvements and upgrades at collecting points included (but are not limited to) a completely new facility (construction ongoing) at the Kandahar division central CP; new roof, new interrogation room, new electrical system, installed personal hygiene facility, and additional security lighting at the division forward CP in the Green Zone; security upgrades at the division forward CP at Ar Ramadi; addition of gravel around latrines at the Brassfield-Mora division forward CP to improve drainage; and a repaired guard tower at the division central CP at the Baghdad International Airport.

Planned upgrades and improvements included (but are not limited to) installation of two 500 gallon water tanks, laundry washers, and shower facility at Ar Ramadi; new cells in a hardened facility that will protect detainees from the elements in Khost; and planned security upgrades and construction of new shower facilities for the CP at Brassfield-Mora. All units inspected were placing a great deal of effort on making improvements and upgrades to existing collecting points for the health and welfare of detainees.

PREVENTIVE MEDICINE

Six of 8 inspected units operated CPs and I/R facilities that did not comply with minimum preventive medicine standards established in policy and doctrine. Two of 8 units met or exceeded minimum preventive medicine standards. The DAIG Team conducted

comprehensive preventive medicine inspections at 8 of the 16 (50%) internment/resettlement (I/R) facilities and collecting points (CPs) visited that were interning detainees.

Leaders and Soldiers from 36 units, both continental U.S. (CONUS) and outside CONUS (OCONUS), were interviewed concerning preventive medicine practices and procedures in detainee operations. There was a widespread lack of preventive medicine staffing, supplies, and equipment to meet the needs of CPs and I/R facilities. This shortfall was compounded by the failure of units to deploy appropriately trained and supplied field sanitation teams. Medical leaders responsible for direct oversight of preventive medicine personnel lacked specific training in detainee operations and field sanitation. I/R facility site selection, design and construction decisions did not incorporate preventive medicine considerations. The capacity of the detainee system was exceeded early in the operations, leading to prolonged holding times at CPs and other areas not prepared for long-term housing of detainees.

There was significant variance in the hygiene and sanitation conditions at CPs and in I/R facilities throughout Afghanistan and Iraq. While major improvements continue to upgrade conditions at most sites, the process has been hampered by shortages of preventive medicine personnel and materiel, problems with site selection and design, and detainee populations that exceed the current system capacity. As of March 2004, Camp Bucca still had potable water sources within a few feet of exposed fecal material; Abu Ghraib continued to struggle with garbage and rodents in living areas; and Kandahar's food service sanitation was extremely poor. Hand washing stations were still absent from 3 of 8 (38%) locations inspected, and sanitary orders had not been published and posted at any detainee facilities in accordance with Army Regulation (AR) 190-8, Enemy Prisoners of War, Retained Personnel, Civilian Internees and Other Detainees, 1 October 1997.

Lack of trained preventive medicine personnel and required field sanitation supplies contributed significantly to deficiencies in hygiene and sanitation at CPs and I/R facilities. Units (97%, 35 of 36) did not deploy with properly trained and equipped field sanitation teams in accordance with AR 40-5, Preventive Medicine, 15 October 1990. Preventive medicine technicians (Military Occupational Specialty 91S) were not deployed in sufficient numbers to support detainee operations, with only one assigned to each Military Police (MP) I/R battalion and none available to support units operating CPs. Preventive medicine detachments at the division level provided support to I/R facilities and CPs when distance and security permitted, but the non-linear battlespace precluded support to the majority of CPs forward of brigade. Shortages of supplies and equipment prohibited preventive medicine personnel from providing complete field sanitation services. Holding times at CPs (up to 54 days; doctrinal maximum is 24 hours) required a more robust infrastructure than units were prepared or resourced to provide.

During interviews and sensing sessions, the DAIG Team noted that (86%, 31-36) leaders and Soldiers were unaware of the specific hygiene and sanitation requirements for CPs and I/R facilities. They relied on "common sense" and contractors to establish local, often unwritten, standards. All (16 of 16) of the interviewed battalion, brigade, and division surgeons said they were not trained in detainee operations and/or preventive medicine and therefore lacked the knowledge to provide adequate oversight for hygiene and sanitation of CPs and I/R facilities. There were no theater- or unit-level policies that addressed preventive medicine requirements for detainee operations. Additionally, there was no evidence of specific medical planning for field sanitation/preventive medicine support to detainee operations.

Despite the many obstacles, recent (March 2004 timeframe) International Committee of the Red Cross (ICRC) inspections of the U.S.-operated I/R facilities in OIF have indicated general satisfaction with the efforts underway to address persistent problems in hygiene and sanitation (although the slow pace of improvements was criticized). As of March 2004, contractors have assumed responsibility for many sanitation functions, including food and water supplies, latrines, laundry, and waste disposal. The most significant problems that persist include overcrowding and insect/rodent control.

The Ryder Report and the Taguba Investigation indicated deficiencies in preventive medicine aspects of detainee operations. The Ryder Report stated that "significant variance in the health, hygiene and sanitation conditions were observed in the detention facilities throughout Iraq." The report referred to ICRC reports that indicated "major progress" in all areas, and further stated that "most facilities have adequate water supplies, sewage management and appropriate food services to comply with the United Nations guidelines." The deficiencies observed were attributed in this report to "inadequate logistical support for facility operations." The Ryder Report pointed out major sanitation problems at Camps Ganci and Vigilant (compounds at Abu Ghraib). Camp Ganci was littered with trash, had large amounts of standing water around latrines, lacked laundry facilities, had insufficient cleaning supplies, and housed detainees in tents that did not provide adequate protection from severe weather or hostile fire. Camp Vigilant had problems with water supply and latrines. The Taguba Investigation did not look at hygiene and sanitation, but it noted that Abu Ghraib and Camp Bucca were "significantly over their intended maximum capacity", with the overcrowding contributing to "poor living conditions." The DAIG Team's findings are consistent with those of the Ryder Report and the Taguba Investigation, but they were not chartered to perform specific evaluations of preventive medicine conditions at U.S.-operated CPs and I/R facilities. While the Ryder Report found most facilities to be in compliance with United Nations guidelines, the DAIG Team inspected I/R facilities and CPs against Army standards (AR 190-8, AR 40-5, and FM 21-10).

MEDICAL TREATMENT

No inspected units supporting detainee operations complied with all medical treatment requirements for enemy prisoners of war and civilian internees, such as monthly height/weight screenings, chest x-rays, and tuberculin skin tests. The DAIG Team found none of the inspected units were following all the medical requirements in accordance with AR 190-8. However, at the time of the inspection all units were attempting to provide detainees with the same quality of medical treatment as that provided to Coalition Forces.

AR 190-8 requires an initial medical screening at I/R facilities for both enemy prisoners of war (EPWs) and civilian internees (CIs). At the time of the inspection, all I/R facilities and collecting points (CPs) were performing a medical screening upon initial in processing, but not to standards. At least one I/R facility (Camp Bucca) had previously provided no medical screening, relying on sick call to discover detainees who required medical treatment. The regulation also requires a continuing monthly medical screening, to include weight measurements that ensure detainees are properly nourished. Two of the 4 I/R facilities (Camp Bucca and the Bagram Internment Facility) were aware of this requirement, and both stated they had started performing these screenings in December 2003. Only 2 of the 4 I/R facilities (Camp Cropper and Bagram Internment Facility) conducted a routine, follow-up monthly

examination for detainees held over one month as required by regulation.

AR 190-8 also requires CIs be administered a "radioscopic chest examination." None of the facilities had performed this examination. At least one facility (Camp Bucca) had no means of diagnosis for tuberculosis until December 2003. At the time of the inspection, all I/R facilities isolated potentially contagious detainees and provided some preventive measures for Soldiers treating these detainees. All I/R facilities and 7 of 12 (58%) inspected collecting points, established medical records for personnel who required medical treatment. At least 3 facilities transferred these records with the detainee when they were medically evacuated. Medical personnel at only one facility stated they would provide detainees with their medical records upon release.

Medical personnel at all facilities stated they provided medical care comparable to that afforded to Coalition Soldiers. The DAIG Team found this to be accurate in most cases, with some diagnosis-specific exceptions. The exceptions occurred when treatment required transportation out of the host nation, the patient required significant psychiatric care, or treatment was of an elective nature. Previously, one unit reported there had been some conflict between AR 190-8 and Coalition Provisional Authority treatment policy, which reportedly dictated that U.S. medical care was only available to detainees to prevent loss of life, limb, or eyesight. In these cases Army medical personnel attempted to maintain the higher standard by providing detainees with all necessary care. All interviewed medical providers stated they did not have the proper equipment for treating a detainee population that included older, chronically ill patients. In one I/R facility a senior medical Noncommissioned officer (NCO) stated that over 50% of his population had diabetes, and he had neither glucometers nor insulin. At another location a medical NCO stated that approximately 75% of his detainees had hypertension, and one-third were diabetics. At least 4 medical personnel and I/R facility commanders described shortfalls in resources to provide adequate psychiatric treatment. At least 2 I/R facilities had severely ill psychiatric patients (detainees who, in the estimation of the facility's medical personnel, required inpatient treatment) who were being treated pharmacologically by non-psychiatrist physicians.

The medical personnel interviewed stated that they did not receive any specific training in detainee operations or were aware of AR 190-8, although most believed they were required to treat detainees to the same standard of care as Coalition Forces. All requested additional training. At least one provider requested Mobile Training Teams to provide in-theater training.

The Ryder Report also noted medical personnel lacked adequate training and guidance on the treatment of detainees. Specifically, this report recommended that CJTF-7, "Publish and distribute all new Policies and SOPs to all affected parties and re-evaluate the application and adherence to medical practices." It went on to recommend that CJTF-7, "Provide continued in-service training to all newly assigned and/or rotating medical personnel on the provisions, rules and responsibilities stated."

(4) Root Cause: Some units did not have thorough plans to upgrade their facilities and in some cases, were not funded for upgrades. Field sanitation teams were not deployed in compliance with AR 40-5 and did not have adequate supplies to provide the services required. None of the units inspected were fully aware of, or trained on the specific medical requirements for detainees in accordance with AR 190-8. Medical leaders were not adequately trained for detainee operations and were unprepared to provide oversight for preventive medicine functions

at collecting points and I/R facilities. Preventive medicine aspects of detainee operations were not appropriately incorporated into medical planning processes. Preventive medicine detachments lacked sufficient personnel on their Modified Tables of Organization and Equipment (MTOEs) to adequately inspect all division collecting points and I/R facilities. Units did not have all the necessary medical equipment or supplies to meet the specific requirements contained in AR 190-8.

(5) Recommendation: CJTF-7 and CJTF-180 ensure all units meet the guidelines for minimum infrastructure standards supporting detainee operations to allow for adequate facilities to house detainees.

Recommendation: CJTF-7 and CJTF-180 implement a safety inspection program for all facilities that support detainee operations to identify and eliminate hazards to Soldiers and detainees.

Recommendation: CJTF-7 and CJTF-180 evaluate current living and working conditions at all facilities housing detainees and take corrective actions to improve the current living and working environment.

Recommendation: CJTF-7 review the physical and operations security requirements and policy/doctrinal procedures to ensure units operating internment/resettlement facilities comply with all requirements.

Recommendation: Force Providers require commanders to have trained and equipped field sanitation teams prior to deployment, and deployed commanders ensure field sanitation teams comply with Army policy.

Recommendation: TRADOC review the preventive medicine detachment force structure to ensure support to all collecting points and internment/resettlement facilities in a non-linear battlespace.

Recommendation: MEDCOM train all medical personnel in the preventive medicine aspects of detainee operations to ensure compliance with policy and the laws of land warfare.

Recommendation: MEDCOM ensure all health care personnel are trained on the medical treatment requirements for detainees in accordance with Army Regulations and ensure that units have the required medical equipment and supplies for treating detainees.

Recommendation: CJTF-7 and CJTF-180 evaluate current detainee medical capabilities and requirements and take corrective action to ensure detainees receive the required medical screening and care.

h. Finding 16:

(1) Finding: Two of 4 internment/resettlement facilities did not segregate enemy prisoners of war from civilian internees in accordance with legal requirements.

(2) Standard: See Appendix E.

(3) Inspection Results: The DAIG Team observed that 2 of the 4 inspected internment/resettlement (I/R) facilities did not segregate enemy prisoners of war (EPWs) from civilian internees (CIs). Inspections of I/R facilities, leader interviews, Soldier sensing sessions, and document reviews showed that there were 46 documented EPWs in Iraq, few of which were segregated from the CI population. Units did not segregate EPWs for 2 reasons: (1) it was too difficult a task because some of the compounds within the internment facility would only have a few EPWs in them, thus wasting space that could be used to house CIs; and (2) they were comingled to support interrogation requirements. Continued failure to segregate EPWs from CIs in Iraq is in contradiction to the legal requirements of GC, Article 84.

The Ryder Report mentioned, "Currently, due to the lack of Iraqi prison facilities and the ongoing consolidation efforts at the Abu Ghraib complex, Iraqi criminals are detained with security internees (generally Iraqi-on-Coalition offenses) and EPWs; though segregated in different cells/compounds. These categories of offenders need to be separated as soon as facility construction and renovation projects permit, especially separating those facilities run by U.S. personnel (for Iraqi criminals). The management of multiple disparate groups of detained persons in a single location by members of the same unit invites confusion about handling, processing, and treatment, and typically facilitates the transfer of information between different categories of detainees. Absent specific mission constraints, intermingling these categories of detainees should be avoided." Abu Ghraib abided by the Ryder Report recommendation regarding segregation of detainees by either releasing EPWs or moving them to other facilities, as the DAIG Team observed no EPWs at Abu Ghraib. In addition, the Ryder Report mentions segregation, but not specifically in the context of EPWs and CIs: "Initiate procedures for segregating Detainees into separate buildings if and where available, based on category of detainee, sex, untried, or sentenced, and severity of offense."

(4) Root Cause: Leaders at all levels were aware of the legal and regulatory requirement to segregate EPWs from CIs. Units did not comply with the segregation standard because they felt it was too difficult a task or they acted to support intelligence requirements.

(5) Recommendation: CJTF-7 segregate enemy prisoners of war and civilian internees to ensure compliance with the Geneva Conventions and Army Regulations.

i. Finding 17:

(1) Finding: Units operating collecting points (42%, 5 of 12), and units operating internment/resettlement facilities (2 of 4), were not adequately resourced with communications equipment, shotguns, and non-lethal ammunition.

(2) Standard: See Appendix E.

(3) Inspection Results: The DAIG Team inspected 12 collecting points and 4 internment/resettlement (I/R) facilities. Five out of 12 (42%) units operating collecting points (CPs), and 2 of 4 (Camp Bucca and Abu Ghraib) units operating I/R facilities experienced equipment shortfalls, including hand-held radios for communications between guards, escorts, and towers; weapon systems with non-lethal ammunition; hand and leg restraint devices; and rubber gloves to safely handle detainees.

The Military Police (MP) I/R battalion at Abu Ghraib experienced equipment shortfalls of weapons, radios, and non-lethal ammunition. This problem was compounded because the MP battalion was augmented with in lieu of (ILO) units (a Marine Infantry company and a Field Artillery battery) to perform MP missions. The MP battalion was short radios, so Soldiers at Abu Ghraib purchased their own commercial hand-held radios to overcome their shortages. These radios were used primarily for communication between tower guards, roving guards, and for detainee escort missions. Lack of batteries and working radios in the units compounded the problem. Leaders and Soldiers stated during interviews and sensing sessions that detainee operations placed additional communication burdens on the units. These commercial hand-held radios lacked the range and the communications security (COMSEC) capabilities required to maintain secure communications. According to interviews and sensing sessions, the ILO MP units did not deploy with the authorized number of shotguns, non-lethal ammunition, and radios for guard companies and escort guard companies under the Modified Table of Organization and Equipment (MTO&E) of an I/R battalion.

The situation at Camp Bucca was slightly different. The I/R battalion was augmented by two Field Artillery batteries that were ILO MP units. According to interviewed and sensed leaders and Soldiers, the MP battalion, to include the ILO units at Camp Bucca, was short authorized hand and leg restraint devices, radios, shotguns, and non-lethal ammunition. Soldiers at Camp Bucca also purchased commercial hand-held radios to overcome unit communication shortages. Like the ILO MP units at Abu Ghraib, the Field Artillery batteries experienced shortages before and after deployment due to MTO&E differences with I/R MP Guard and Guard Escort companies and experienced many of same impacts that the units at Abu Ghraib faced.

Based on interviews and sensing sessions, the collecting points at Baghdad (Green Zone), Tikrit, Baghdad International Airport (BIAP), Brassfield-Mora, and Ar Ramadi all had equipment shortages. Soldiers at the division forward collecting points at Brassfield-Mora and Ar Ramadi said that they did not have enough radios for detainee operations. The forward and central collecting points at the Green Zone, Tikrit, Ar Ramadi, and BIAP experienced shortages in hand and leg restraint devices. Collecting points at the Green Zone and Brassfield-Mora had difficulties in acquiring identification bracelets. All five of the collecting points mentioned above suffered shortages in rubber gloves for the handling of detainees.

(4) Root Cause: Combat support MPs and in lieu of MP units are not adequately equipped to perform detainee operations.

(5) Recommendation: TRADOC identify minimum equipment requirements for detainee operations to ensure successful unit mission accomplishment.

j. Finding 18:

(1) Finding: All inspected point of capture units established ad hoc kits containing necessary items and supplies for detainee field processing, but the items they contained and their quantities varied from unit to unit.

(2) Standard: See Appendix E.

(3) Inspection Results: Current operations involving the securing and field processing of detainees require specific equipment and paperwork. A "Detainee Field Processing Kit" would assist all units in processing detainees. Based on leader and Soldier interviews, the DAIG Team found that capturing units had established some type of ad hoc kit, which included a variety of items required for securing and field processing a detainee, however, the contents and quantities varied from unit to unit. Some units had more complete kits than others.

These kits were put together at unit level with no guidance from higher and no standardization except generally for the type of forms required for field processing. Capturing units developed the kits by trial and error over a period of time to streamline the processing of detainees to the forward collecting points. In some units, leaders and Soldiers were not aware of all the processing requirements for detainees for evacuation or transfer to forward collecting points. They expressed concern over not knowing these requirements and felt that if the kit had been established through doctrine, it would have expedited and standardized the field processing of detainees.

Some of the more complete kits contained copies of the required forms from AR 190-8, Enemy Prisoners of War, Retained Personnel, Civilian Internees and Other Detainees, 1 October 1997, such as DA Form 4137, Receipt for Evidence/Property Custody Document; DD Form 2745, Enemy Prisoner of War (EPW) Capture Tag; DA Form 2823, Sworn Statement; and the Coalition Provisional Authority (CPA) Forces Apprehension Form (OPERATION IRAQI FREEDOM only). Other items generally found in the more complete kits were flexi-cuffs, string or wire (to attach the Capture Tag or CPA Form to the detainee), large plastic bags (to hold evidence, personal effects and other large confiscated items), small zip-lock plastic bags (to hold currency or small valuable items), an instant or digital camera, hearing protection, sandbags, bandages, or blacked-out goggles (to cover eyes), and in times of cold weather, blankets for the detainees.

(4) Root Cause: Capturing units did not have doctrinal guidance to follow in preparing or funding detainee kits that enabled units to safely and efficiently field process detainees.

(5) Recommendation: TRADOC establish and identify resource requirements for a standardized "Detainee Field Processing Kit" that will enable capturing units to properly secure and process detainees quickly, efficiently, and safely.

k. Finding 19:

(1) Finding: All inspected units had adequate transportation assets to evacuate and/or transfer detainees from points of capture to collecting points, and eventually to internment/resettlement facilities.

(2) Standard: See Appendix E.

(3) Inspection Results: The DAIG Team determined that inspected units had adequate transportation assets to evacuate, transfer, or repatriate detainees. Only a few units experienced minor difficulties arranging transportation, usually during surge periods. These transportation shortages were usually temporary problems that were resolved through coordination with supporting units.

Leaders and Soldiers stated that supporting units, such as forward support and main support battalions, were able to assist in providing transportation assets if capturing units were hampered due to other ongoing missions when required.

Capturing units typically transported detainees to the battalion or division forward collecting points in the back of High Mobility Multi-Wheeled Vehicles or Bradley Fighting Vehicles. Guard ratios and the numbers of accompanying security vehicles were generally well planned out. Most units took advantage of resupply assets to move detainees across the battlefield.

(4) Root Cause: Units were planning for and using transportation assets efficiently to move detainees across the battlefield and through the system.

(5) Recommendation: Commanders continue to stress the importance of planning and providing for adequate transportation assets to support continuing detainee operations.

I. Finding 20:

(1) Finding: Common leader training in professional military schools contains only one detainee operations task.

(2) Standard: See Appendix E.

(3) Inspection Results: The DAIG Team found that leaders and Soldiers from 87% (53 of 61) of the units that commented on Professional Military Education (PME) indicated that their PME common core does not train them to conduct detainee operations. The only PME courses that cover detainee operations training in their common core are during pre-commissioning, Warrant Officer Candidate School and the Primary Leadership Development Course. The Noncommissioned officers (NCOs) interviewed and sensed said they received little detainee operations training in their PME courses. These same NCOs talked more specifically about the Situational Training Exercises (STX) that are conducted at the end of each level of NCOES through the Advanced Noncommissioned Officer Course (ANCOC). Their STX training was force-on-force play using Multi-Integrated Laser Engagement System (MILES), and detainee operations training ceased after the point of capture.

The NCOs experienced difficulty in filling out and completing the required detainee apprehension forms correctly, which included witness statements. They also experienced difficulty in creating a detailed list and accounting for captured detainee property and evidence. The NCOs agreed that there is a training shortfall dealing with detainee classification, and status and treatment afforded to each classification under the provisions of the Geneva Convention. STXs did not cover the classifying of detainees or the paperwork involved in field processing detainees. Their PME training for detainee operations only covered the processing of enemy prisoners of war (EPW). Leaders and Soldiers interviewed and sensed indicated a need to incorporate detainee operations tasks into their PME common core programs of instruction (POI). The current operating environment has evolved and Soldiers at all levels must have a clear understanding of and how to execute detainee operations in a non-linear battlespace. The PME must apply lessons learned quickly to adjust their training to what is occurring in the current operating environment. Interviewed leaders and Soldiers all said that PME is a very important training base, but that it must keep up with current operational lessons

learned and evolving tactics, techniques and procedures.

Interviewed and sensed leaders and Soldiers stated that the Law of War training they received prior to deployment did not differentiate between the different classifications of detainees causing confusion concerning the levels of treatment. Even though this confusion existed, most leaders and Soldiers treated detainees humanely.

Currently, TRADOC has integrated one detainee operations task into the PME common core: Process Captives, (191-000-0001). The pre-commissioning course, Warrant Officers Candidate School and NCOs at the Primary Leadership Development Course are only courses receiving training on this task.

The U.S. Army Military Police School (USAMPS) has several ongoing initiatives that began in December 2003. USAMPS is currently in the process of creating and revising their detainee operations programs of instruction and training support packages using lessons learned from OPERATION ENDURING FREEDOM (OEF) and OPERATION IRAQI FREEDOM (OIF). Military Police (MP) NCOs attending the MP NCO Academy receive training on the following new and revised detainee operations tasks:

- Introduction to Detainee operations
- Communication with detainees
- Use of Force and Detainees
- Detainee Frisk, Undress, Cell and area search operations
- Restraint procedures and Detainees
- The Geneva Conventions and detainee operations

USAMPS has currently revised the tasks to provide updated programs of instruction and training support packages to support detainee operations training at all PME schools and colleges.

(4) Root Cause: There are currently not enough programs of instruction and training support packages available to the Professional Military Education schools and colleges that support detainee operations training.

(5) Recommendation: TRADOC integrate standardized detainee operations training into all Army proponent school common core programs of instruction and training support packages.

m. Finding 21:

(1) Finding: Leaders and Soldiers assigned to 69% (46 of 67) of inspected units stated they desired additional home station training; and pre- and post mobilization training to assist them in performing detainee operations.

(2) Standard: See Appendix E.

(3) Inspection Results: The DAIG Team found that leaders and Soldiers assigned to 27 of 39 (69%) of inspected Active Component (AC) units indicated their home station training did not prepare their units to perform detainee operations. Individual and collective training at home station was concentrated on fighting an enemy on a linear battlefield, according to interviewed

and sensed leaders and Soldiers. Their units did little in the way of training on detainee operations. All inspected units did execute the Common Military Training (CMT) as outlined in Army Regulation 350-1, Army Training and Education, 9 April 2003. However, the CMT classes on the Law of War, the Geneva Conventions, and Code of Conduct were generic and did not address the specific application of detainee operations in the current operating environment. These same leaders and Soldiers said their detainee operations training only covered field processing of enemy prisoners of war (EPWs) and not other classifications of detainees. The training these units received on field processing of detainees was comprehensive when dealing with EPWs only.

Once deployed in support of OPERATION ENDURING FREEDOM (OEF) and OPERATION IRAQI FREEDOM (OIF), leaders and Soldiers identified a training shortfall dealing with the handling of the different classifications of detainees and their special handling procedures. Units did not have established tactics, techniques, and procedures (TTPs) or standing operating procedures (SOPs) to cover the handling and processing of different classifications of detainees. This lack of training by point of capture units placed a burden on their resources (manpower, logistics and medical). To compound the problem, a number of leaders and Soldiers were unaware of the specific Army regulation or field manuals that govern detainee operations.

Soldiers assigned to division MP units told the DAIG Team that they did not train at home station on the five MP functional areas that were assigned to the units in theater. One example concerned a division MP platoon conducting maneuver and mobility support training at home station and then being assigned the internment/resettlement (I/R) function after deployment. These Soldiers said that their training at home station should include all 5 of the MP battlefield functions. This agrees with the Taguba Investigation finding that states, "Those military units conducting I/R operations must know of, train on, and constantly reference the applicable Army Doctrine and CJTF command policies."

Reserve Component (RC) leaders and Soldiers assigned to 64% (14 of 22) of inspected RC units stated the training they received at their mobilization sites did not prepare them to conduct detainee operations. OEF and OIF experienced RC career course captains, interviewed at the U.S. Army Military Police School (USAMPS), also said their units did not receive adequate training at their mobilization sites to prepare them to conduct detainee operations. Training at some mobilization sites concentrated on improving combat soldiering skills and to pass the Common Task Test (CTT). Leaders and Soldiers were not required to attend deployment briefings at these mobilization sites, also these units maintained no tracking systems to ensure that every Soldier received mandatory training.

Interviewed and sensed leaders and Soldiers said they were not given enough time at the mobilization sites to conduct collective unit level training. Some units had just enough time to complete their central issue facility (CIF) draw, and complete the Soldier readiness checks (SRC) before deploying overseas. Training was considered and treated like a "revolving door" at some mobilization sites. Interviewed leaders and soldiers assigned to 64% (14 of 22) of inspected RC stated they were not given a clear mission statement prior to mobilization and were not notified of their MP mission until after deploying. The units received their MP mission upon their arrival in theater. Interviewed Soldiers gave examples of being placed in stressful situations in internment/resettlement (I/R) facility with thousands of non-compliant detainees and not being trained to handle them. The lack of a mission statement limited units in support of

OEF 4 and OIF 1 from training on mission essential tasks at their mobilization site. This is also supported by the findings in the Taguba Investigation.

Once deployed, these MP units had no means to gain access to the necessary tactics, techniques, and procedures (TTPs) to train their Soldiers on the MP essential tasks based on their new missions. Regulations and field manuals were digitized, but unit leaders and Soldiers had no access to computers or the internet. It was very difficult to train Soldiers on MP missions early in their deployment. Interviewed leaders and Soldiers assigned to 64% (14 of 22) of inspected RC units stated they were assigned battlefield missions that they had never received training on at their home station or at their mobilization site. Soldiers provided examples of unit training primarily as an escort or guard MP company, but once deployed the unit was assigned I/R or law and order missions. A consensus among leaders and Soldiers was that their units should have concentrated their training on all 5 of the MP functional areas. They also agreed that all MP units should be resourced to conduct all 5 MP functional areas.

Interviewed leaders and Soldiers assigned to 5 of 6 inspected in lieu of (ILO) Military Police (MP) units did not receive detainee operations training at their mobilization site. These ILO units deployed into theater with little post-mobilization training on detainee operations and were assigned the ILO MP Security missions. Soldiers assigned to these units had little knowledge on what to do, but just trusted in their leaders to provide them good guidance. The ILO MP units inspected that deployed in support of OIF 1 were not given a clear mission statement prior to mobilization and were not notified of their ILO MP mission until after deploying. The units received their ILO MP mission upon their arrival in theater and were given a just few days to conduct a battle-handover with the outgoing units.

Once deployed, the ILO MP units had difficulty in gaining access to the necessary tactics, techniques, and procedures (TTPs) to train their Soldiers on the MP essential tasks based on their new missions. Army regulations and field manuals were digitized and unit leaders and Soldiers had no access to computers or the internet. It was very difficult to train Soldiers on MP missions early in their deployment. During OIF 1 there were no training programs in theater to train units designated ILO MP before they assumed their ILO MP Security missions. Leaders and Soldiers interviewed and assigned to these ILO MP units were assigned battlefield missions that they had never received training on at their home station or at their mobilization site.

Interviewed and sensed leaders and Soldiers stated that the Law of War training they received prior to deployment did not differentiate between the different classifications of detainees, causing confusion concerning the levels of treatment. Even though this confusion existed, most leaders and Soldiers treated detainees humanely. Interviewed and sensed leaders and Soldiers said the Army has the necessary training tools in place, but doctrine and/or policy needs to address and apply lessons learned more quickly to incorporate changes coming from OEF and OIF. The Common Task Test (CTT) was identified by these leaders and Soldiers as an excellent training tool, but the tasks require updating to comply with changes evolving from the current operating environments in OEF and OIF. CTT would be an excellent tool to integrate detainee operations into the force by using a multi-echelon training approach. The CMT tasks outlined in AR 350-1 should be updated to address the different classifications of detainees and how to apply the Geneva Conventions and the Law of War to each type of detainee. Interviewed Soldiers complained about the lack of detainee operations training their units received during their respective rotations at the National Training Center (NTC) or the Joint

Readiness Training Center (JRTC). Soldiers said detainee operations during their rotation at NTC or JRTC was not evaluated beyond the point of capture and lacked realism.

Post-mobilization training for units that deployed in support of OEF 5 and OIF 2 consisted of a comprehensive training program ending in a Mission Rehearsal Exercise (MRX) to assess units' ability to execute wartime missions. Leaders and Soldiers interviewed said that all Soldiers were required to sign-in for all mandatory training received at the mobilization site. Soldiers deploying in support of OEF 5 and OIF 2 were required to sign a statement acknowledging the training they received at their mobilization site. These Soldiers were being tracked by name and by unit. This process ensured that all mobilized leaders and Soldiers were accounted for and trained. Mobilization site training was broken down into 7 Modules culminating in a Simulation Exercise (SIMEX):

Module 1: Soldier Readiness Packet, Central Issue Facility, Theater Specific Individual Readiness Training briefings

Module 2: NBC survival tasks, Land Navigation, Communications

Module 3: Crew and Individual Basic and Advanced Weapons Qualification Skills,

Leader Training & New Equipment Training

Module 4: Specialty Training

Module 5: Squad and Platoon Training

Module 6: Platoon Training

Module 6.1: Combat Support/Combat Service Support training

Module 7: Multi-Echelon Training / Support and Stability Operations Training

(CAPSTONE)

Brigade SIMEX that covers Battalion and Brigade level collective tasks.

Modules 1 and 2 are augmented with a series of leader and Soldier concurrent training on Common Task Test supporting tasks. Leaders and Soldiers, deployed in support of OIF 2 and OEF 5, were very complimentary of the training they received at their respective mobilization sites. These training modules provided unit commanders the ability to execute detainee operations training during Modules 4, 5, 6, and 7. Interviewed leaders and Soldiers that deployed in support of OIF 2 said that post-mobilization training helped them once they deployed into theater. Forces Command (FORSCOM) issued specific guidance on the collective and individual tasks units must train on prior to deploying in support of OEF and OIF. These tasks did not prepare units to conduct detainee operation in the current operating environment.

The Combat Training Centers (CTC) are using an internal After Action Review (AAR) process in order to continue making improvements to their detainee operations scenario and to include the synchronization and integration of detainee operations into every unit's rotation. NTC's current focus is on conducting detainee operations to the doctrinal standard and by incorporating approved procedures used in OIF. Both JRTC and NTC have incorporated detainee operations into their Mission Rehearsal Exercises (MRXs) and Contemporary Operational Environment High Intensity (COE HI) rotations.

In the future, the Combat Training Centers' (CTCs) detainee operations training during MRX scenarios will be based upon reports and lessons learned from OIF and/or OEF, to include 1st Armored Division SOPs/TTPs, and doctrinal guidelines. All rotating units will be required to establish and operate a collecting point of some kind as part of their rotations. The CTCs are striving to replicate the best scenarios for the current operating environment. The G3, in

coordination with TRADOC, the Office of the Provost Marshal General, and the Office of The Judge Advocate General (OTJAG) has initiated a training integration assessment for improving detainee handling from point of capture to repatriation, to include a review of CTT and specialized MP training across the Army during Combat Training Center (CTCs) rotations, MRXs and TRADOC institutional training. This assessment began in December 2003 and is currently ongoing with no projected completion date.

The G3, in coordination with the U.S. Army Training and Doctrine Command (TRADOC), the Office of the Provost Marshal General, and the Office of The Judge Advocate General (OTJAG), has initiated a training integration assessment for improving detainee handling from point of capture to repatriation, to include a review of CTT and specialized MP training across the Army during CTCs rotations, MRXs and TRADOC institutional training. This assessment began in December 2003 and is currently ongoing with no projected completion date.

TRADOC's institutional training assessment is focusing on the Law of War and the 5Ss and T (Search, Silence, Segregate, Safeguard, Speed, and Tag) regarding EPWs throughout the proponent schools. USAMPS has formed an MP subject matter expert team to develop a process to analyze, identify, evaluate, and integrate lessons learned from all CONUS/OCONUS MP operations. TRADOC, in coordination with OTJAG, is currently determining the feasibility of expanding or adjusting Law of War training in the proponent schools to include procedures for handling of detainees.

In January 2004, the U.S. Army Military Police School (USAMPS) sent a Mobile Training Team (MTT) to JRTC to conduct "train-the-trainer" education for their observer controllers (O/Cs) on detainee operations. The MTT training covered detainee operations, personal safety, forced cell movements, restraint procedures, communication with detainees, and case studies. USAMPS is also coordinating with the NTC for a MTT to conduct the same training.

Currently, the USAMPS MTT mission is to train identified CONUS/OCONUS units performing detainee operations or I/R missions in support of OIF 2 on select and approved tasks to enhance their capabilities of mission accomplishment. The 31E detainee operations support and MTT is comprised of a total of 29 (31E) Soldiers. The MTT has trained leaders and Soldiers from the following units: 160th MP Battalion (BN), 107th FA Battery, 172nd FA Battery, 391st MP BN, 152nd FA Battery, K 3/24 INF-USMC, 439th CLD, MEK: 336th MP BN, 579th FA Battery, and the 1/124th AR SQ. A total of 565 leaders and Soldiers have been trained as of 7 May 2004. The following units are scheduled: 1st INF DIV (9 May-11 Jun), 1st CAV DIV (24 May-12 JUN), 1st MEF (6-30 Jun), and MNB-N (TF-Olympia) (14-30 Jun).

(4) Root Cause: There is no prescribed detainee operations training program for units to train at home station. A majority of Reserve Component MP Units who deployed in support of OIF 1 were not told of their missions until they arrived into theater and their area of responsibility.

(5) Recommendation: The G3 integrate a prescribed detainee operations training program into unit training.

Recommendation: CFLCC and Force Providers coordinate to ensure, where possible, units are aware of their assigned mission upon mobilization so they can train for their specific mission.

Recommendation: FORSCOM integrate a standardized detainee operations training package as part of pre- and post-mobilization training.

Recommendation: CFLCC ensure that ILO MP units are trained before they assume their ILO MP missions.

n. Finding 22:

(1) Finding: To offset the shortage of interrogators, contractors were employed, however, 35% (11 of 31) of contract interrogators lacked formal training in military interrogation policies and techniques.

(2) Standard: See Appendix E.

(3) Inspection Results: 35% (11 of 31) Of the contract interrogators in OPERATION IRAQI FREEDOM (OIF), 35% (11 of 31) had not received formal training in military interrogation techniques, policy, and doctrine. These personnel conducted interrogations using skill sets obtained in previous occupational specialties such as civilian police interrogator or Military Intelligence (MI) officer. The lack of specific training in military policies and techniques has the potential of placing these interrogators at a higher risk of violating Army policies and doctrine, and decreasing intelligence yield. 65% (20 of 31) of contract interrogators in OIF had previous experience as Army or Marine interrogators (Army 97E military occupational specialty or Marine Corps 0211) where they received formal school training in military interrogation techniques and procedures. These individuals had received formal military interrogation training an average of 9.5 years prior to employment as interrogators in OIF. The range of time from having completed basic military interrogation training was 1 to 25 years. Field Manual (FM) 34-52, Intelligence Interrogation, 28 September 1992, is the base document for Army interrogation doctrine. Persons trained in interrogation techniques prior to publication of the current version of the FM would have been trained on some doctrinal techniques that are no longer valid.

Contract interrogators were a force multiplier in OIF, supplementing a shortage of military interrogators. Contract interrogators were used to perform screenings and interrogations at collecting points (CPs) and in internment/resettlement (I/R) facilities to free military interrogators and counterintelligence agents to perform tactical missions at points of capture and CPs.

CACI International, Inc. is the civilian company contracted through the Department of the Interior to provide civilian interrogators for OIF. CACI has provided a total of 31 contract interrogators since the blanket purchase agreement (contract) was issued on 14 August 2003. As of 17 May 2004, 19 contract interrogators were deployed in support of OIF, and 12 contract interrogators have returned to the United States citing personal or family reasons.

The CJTF-7 Statement of Work (SOW) required contract interrogators to be the civilian equivalent of military occupational specialty 97E (Human Intelligence Collector) or 351E (Human Intelligence Collection Technician), strategic debriefer (completed the DoD Strategic Debriefing Course), or an individual with a similar skill set. Contract interrogators that only meet the requirements of "strategic debriefer" or "similar skill sets" may not have training in military-

specific interrogation techniques and procedures as taught in the 97E and 351E qualification courses. This training is specific to human intelligence exploitation and includes collection priority, battlefield screening, planning and preparation, authorized approaches, methods of questioning, and termination of interrogations. It also includes 192 hours of direct and indirect training on the laws of land warfare, emphasizing compliance of all military interrogation techniques with the Geneva Conventions and Army policy.

The DAIG Team inspected the resumes of all 31 individuals hired as contract interrogators by CACI. 65% (20 of 31) were prior service military interrogators who had been awarded the Army 97E MOS or Marine Corps 0211 MOS. These individuals had received formal military interrogation training an average of 9.5 years prior to employment by CACI (range: 1-25 years). Of the contractors without prior military service, 35% (11 of 31) had "similar skill sets" acquired in related military or civilian experience (e.g., military intelligence/counterintelligence agent, police interrogator, intelligence analyst, and police officer).

Prior to May 2004, there was no CACI or CJTF-7 requirement for all contract interrogators to receive formal, comprehensive, military-specific interrogator training prior to performing interrogations in OIF. While in Iraq the DAIG Team did not find evidence of a formal training program for contract interrogators. The DAIG Team requested from the J2, CJTF-7, both in Iraq and upon return to the United States, a training plan or program of instruction (POI) outlining a formal training program. On 19 May 2004, the Chief, CJ2X, CJTF-7 provided an email message to the DAIG Team stating that prior to February 2004, new contract interrogators working at the Joint Interrogation and Debriefing Center (JIDC) received familiarization training, consisting of briefings on the approved interrogation approach techniques and the Geneva Conventions, "left seat-right seat ride" training, and evaluation by experienced interrogators prior to conducting interrogations. On 21 May 2004, the Chief, CJ2X, CJTF-7 provided an email message stating that in February 2004, the JIDC began a two-part newcomer's training/orientation for all contract interrogators deployed to OIF. This training consisted of an organizational overview, interrogation policy briefing, tour of the facilities, and "left seat-right seat ride" training on interrogation duties and responsibilities. The message stated that documentation of this training began in May 2004.

In interviews conducted during the inspection, when four contract interrogators were asked about in-theater training, there were three different responses. One stated he received no in-theater training of any kind. Two stated training was provided on the Geneva Conventions and the interrogation approach techniques, with some additional time spent observing experienced interrogators. One stated he received 2 weeks of "right seat" training at Abu Ghraib, followed by 1 week performing supervised interrogations. Two military interrogators interviewed stated, "While some contract interrogators were fine, some lacked understanding of proper interrogation policies and procedures." In contrast, the DAIG Team interviewed 5 leaders and Soldiers who found contract interrogators to be adequate to very good.

Two specific incidents were described to the DAIG Team where Army personnel stated they saw contract interrogators using techniques and procedures inconsistent with Army policy and doctrine (e.g., pouring water over detainees' heads while in stress positions); the chain of command was already aware of this incident. In one of these incidents military interrogators at that location were reportedly using the same techniques. The DAIG Team did not observe any improper interrogation techniques during the inspection. A DAIG Team member observed two

contract interrogators performing interrogations; both interrogations were conducted using tactics, techniques, and procedures in accordance with Army policy and doctrine.

The Taguba Investigation cited a contract interrogator who gave an MP non-doctrinal guidance that violated Army policy in order to facilitate conditions for interrogation. The contract interrogator has since requested to return to the United States. A lawyer representing CACI International stated that the Army has not requested, and no contract interrogators in OIF have received, administrative or disciplinary action as a result of improper performance of duties.

At the time of the inspection there were no contract interrogators employed in OPERATION ENDURING FREEDOM (OEF). In March 2004, CJTF-180 contracted with SYTEX, Inc. for 4 contract interrogators, all of which were assigned to the I/R facility at Bagram, Afghanistan. Two of the 4 contract interrogators have military interrogation training, and the other 2 are former police officers. The senior Army interrogator assigned to CJTF-180 stated that upon arrival at Bagram the contract interrogators were provided training on interrogation planning and preparation, interrogation approaches, Geneva Conventions, questioning methods, report writing, and the CJTF-180 interrogation approach techniques. They also underwent left/right seat interrogation training. CJTF-180 provided the DAIG Team with a training plan that outlines the above.

In summary, contract interrogators in OIF met the requirements of the CJTF-7 C2 Interrogation Cell SOW. The SOW did not mandate military interrogation training as a prerequisite for employment. While some training may have occurred at Abu Ghraib, there is no evidence of a formalized POI for contract interrogators. All contract interrogators should receive training on specific theater and Army techniques, policies, and doctrine for conducting military interrogations. This requirement should be reflected in the CJTF-7 C2 Interrogation Cell SOW.

(4) Root Cause: The CJTF-7 C2 Interrogation Cell SOW did not require contract interrogators to be trained in military interrogation procedures, policy, and doctrine. Pre-deployment and in-theater training for contract interrogators on military interrogation techniques, policy, and doctrine did not occur or was inconsistent.

(5) Recommendation: The CFLCC contracting officer representative modify the CJTF-7 C2 Interrogation Cell Statement of Work to require civilian interrogators to be former military interrogators trained in current interrogation policy and doctrine or receive formal training in current military interrogation policy and doctrine.

o. Finding 23:

(1) Finding: Interviewed leaders and Soldiers indicated their Law of War refresher training was not detailed enough to sustain their knowledge obtained during initial and advanced training.

(2) Standard: See Appendix E.

(3) Inspection Results: Leaders and Soldiers from inspected units who commented on Law of War training stated they did receive some Law of War training prior to deploying, but 57% (272 of 474) of leaders and Soldiers indicated that the training was generic and did not prepare them for the current operating environment. The Level B Law of War training was

normally given by the brigade legal advisor. Law of War training is required for leaders and Soldiers throughout their military careers commensurate with their duties and responsibilities. There are currently 3 levels of training for the Law of War. Level A training is conducted during Initial entry training (IET) for all enlisted personnel and during basic courses of instruction for all warrant officers and officers. Level B training is conducted in units for officers, warrant officers noncommissioned officers (NCOs) and enlisted personnel and incorporates the missions of the unit. Level C training is conducted in Professional Military Education (PME).

Currently in IET, Level A Law of Land warfare training is designed to advise the Soldier on his rights, duties, and obligations under the Hague Convention of 1907, the Geneva Conventions of 1949, and the customary Law of War. The program of instruction used for this training is dated 1 October 1998, and is scheduled for one hour, which includes 36 minutes of classroom instruction on the principles, spirit, and intent of the Hague and Geneva Conventions; the laws of war prohibiting unnecessary destruction; and the laws of war requiring humane treatment of prisoners of war (PWs), other captured and detained persons, and civilians. In this portion of the training, Soldiers become familiar with their obligations not to commit war crimes and to report all violations of the laws of war, and the significant provisions of the Geneva Convention relative to the treatment of prisoners of war (EPWs). The other 24 minutes consists of a television tape covering the Law of Land Warfare, and emphasizes "honor" and the Army's Values. The tape stresses that each Soldier has a personal stake in knowing about these conventions and in understanding how they work. Soldiers are taught to comply with these provisions and that failure may subject them to provisions under the Uniform Code of Military Justice (UCMJ). This program of instruction is given to all IET Soldiers who enter the Army.

Level B Law of War training is designed to sustain the training received in IET and PME. Unit commanders are responsible for planning and executing Level B Law of War training. Level B training should reinforce the basic principles set forth in "The Soldiers' Rules." Level B training should be designed around current missions and contingency plans, including anticipated geographical areas of deployment or rules of engagement. Commanders ensure that Law of War training is integrated into unit training activities, field training exercises, and unit external evaluations. There are no Office of The Judge Advocate General (OTJAG) programs of instructions for Level B training. Level B training is designed to be refresher training, used to reinforce previous training and/or to sustain/regain previously acquired skills, knowledge, and experiences. Commanders determine the need for refresher training based on assessment of individual and unit proficiency. Leaders and Soldiers complained about the content and quality of their unit level B Law of War training during interviews and sensing sessions. All agreed that their Level B Law of War training needed more structure as part of Common Military Training (CMT) to help them to better function in the current operating environment.

Level C Law of War training is conducted in The Army School System (TASS); TASS is a composite school system consisting of Army National Guard (ARNG), U.S. Army Reserve (USAR), and Active Army institutional training systems. TASS conducts IET; functional training (Military Occupational Specialty (MOS), Area of Concentration (AOC), Additional Skill Identifier (ASI), and Language Identification Code (LIC)); reclassification; and officer, warrant officer, NCO, and DA civilian professional development training and education through both standard resident and distance learning courses. Level C Law of War training emphasizes officer, warrant officer, and NCO responsibilities for their performance of duties in accordance with the Law of War obligations of the United States; Law of War issues in command planning and execution of combat operations; and measures for the reporting of suspected or alleged war

crimes committed by or against U.S. or allied personnel. There are currently 2 PME common core Law of War tasks:

1. Conduct small unit combat operations according to the law of war (Task #181-431-1001) – taught at the Pre-commissioning Course (PRE), the Officer Basic Course (OBC), the Warrant Officer Candidate School (WOCS), the Basic Noncommissioned Officer Course (BNCOC), and the Primary Leadership Development Course (PLDC). This task helps leaders identify key provisions of the Hague and Geneva Conventions and those acts that constitute violations and war crimes against noncombatants, property, POWs, and medical transports/facilities, and prevent the engagement of unlawful targets and the excessive use of force. This task is designed to be programmed training, with specific learning objectives and an evaluation for proficiency. The task is trained by an instructor/trainer in a structured manner and serves as the foundation for other training. Normally the task is a qualification requirement and is presented and evaluated using the prescribed training conditions and performance standards. This task takes 100 minutes to train.

2. Conduct company level combat operations consistent with the laws of war and laws affecting peacekeeping and peacekeeping operations, rules of engagement, and other legal constraints (Task # 181-433-1001) – taught at the Captain's Career Course (CCC) and the Warrant Officer Advanced Course (WOAC). This task helps leaders prevent law of war violations and war crimes against protected noncombatants, property, POWs, and medical transports/facilities, and prevent engagement of unlawful targets and excessive use of force. This task is designed to be programmed training. This task has specific learning objectives and an evaluation for proficiency; is conducted by an instructor/trainer in a structured manner; serves as the foundation for other training; normally is a qualification requirement; and is presented and evaluated using the prescribed training conditions and performance standards. This task also takes 100 minutes to train.

Interviewed and sensed leaders and Soldiers stated that the Law of War training they received prior to deployment did not differentiate between the different classifications of detainees, causing confusion concerning the levels of treatment. Even though this confusion existed, most leaders and Soldiers treated detainees humanely.

TRADOC, in coordination with the Office of The Judge Advocate General, is currently determining the feasibility of increasing or adjusting Law of War training in the proponent schools to include procedures for handling civilian internees and other non-uniformed personnel on the battlefield.

(4) Root Cause: Level B Law of War training is a CMT task, coded "R" (Refresher), that does not require the training to have specific learning objectives and taught by an instructor/trainer in a structured manner.

(5) Recommendation: The G3, in coordination with the Office of The Judge Advocate General, mandate that Level B Law of War training have specific learning objectives, be conducted by an instructor/evaluator in a structured manner, and be presented and evaluated annually using the established training conditions and performance standards.

[Next page intentionally left blank]

Chapter 6

Summary of Recommendations

1. **Purpose:** The purpose of this chapter is to list all of the recommendations proffered in the report. Some recommendations may be similar to others; however, all recommendations are included here.

2. **Recommendation for Implementation:** Director, Army Staff task out appropriate recommendations and track compliance to Department of the Army Staffs and Major Commands. The Acting Secretary of the Army submit appropriate recommendations to the Joint Staff for consideration and implementation as appropriate by units deployed in OPERATION ENDURING FREEDOM and OPERATION IRAQI FREEDOM.

3. **Chapter 3, Capture, Care, and Control of Detainees:**

a. **Recommendation:** CJTF-7 and CJTF-180 continue to emphasize compliance with the requirements regarding the humane treatment of detainees.

b. **Recommendation:** Commanders continue to stress the importance of humane treatment of detainees and continue to supervise and train Soldiers on their responsibility to treat detainees humanely and their responsibility to report abuse.

c. **Recommendation:** Commanders enforce the basic fundamental discipline standards of Soldiers, provide training, and immediately correct inappropriate behavior of Soldiers towards detainees to ensure the proper treatment of detainees.

d. **Recommendation:** Commanders assess the quality of leadership in units and replace those leaders who do not enforce discipline and hold Soldiers accountable.

e. **Recommendation:** TRADOC develop and implement a train-the-trainer package that strongly emphasizes leaders' responsibilities to have adequate supervision and control processes in place to ensure the proper treatment of detainees.

f. **Recommendation:** TRADOC integrate training into all Professional Military Education that strongly emphasizes leaders' responsibilities to have adequate supervision and control processes in place to ensure the proper treatment of detainees.

g. **Recommendation:** The G3 require pre-deployment training include a strong emphasis on leaders' responsibilities to have adequate supervision and control processes in place to ensure proper treatment of, and prevent abuse of, detainees.

h. **Recommendation:** CJTF-7 expand Camp Bucca as an internment/resettlement facility in order to transfer detainees from Camps Ganci and Vigilant, and phase out U.S. Armed Forces detainee operations at Abu Ghraib completely.

4. Chapter 4, Interrogation Operations:

a. Recommendation: TRADOC revise doctrine to address the criteria for establishing and operating collecting points to enable commanders to more effectively conduct intelligence exploitation in a non-linear battlespace.

b. Recommendation: TRADOC develop a single document for detainee operations that identifies the interdependent and independent roles of the Military Police custody mission and the Military Intelligence interrogation mission.

c. Recommendation: TRADOC establish doctrine to clearly define the organizational structures, command relationships, and roles and responsibilities of personnel operating interrogation facilities.

d. Recommendation: The Provost Marshal General revise, and the G2 establish, policy to clearly define the organizational structures, command relationships, and roles and responsibilities of personnel operating interrogation facilities.

e. Recommendation: The G3 direct the incorporation of integrated Military Police and Military Intelligence detainee operations into field training exercises, home station and mobilization site training, and combat training center rotations.

f. Recommendation: TRADOC and G2 ensure documentation of unit organizations meet interrogator personnel manning requirements, authorizations, and capabilities in order to provide commanders with timely intelligence.

g. Recommendation: The CFLCC contracting officer representative ensure enough Category II interpreters are hired to support timely intelligence exploitation of detainees.

h. Recommendation: TRADOC continue the integration of the G2X/S2X Battle Staff Course for all Military Intelligence officers assigned to G2X/S2X positions.

i. Recommendation: TRADOC integrate additional training on the collection and analysis of HUMINT into the Military Intelligence Officer Basic Course program of instruction.

j. Recommendation: TRADOC, in coordination with G2 and TJAG, revise doctrine to identify interrogation approach techniques that are acceptable, effective and legal for non-compliant detainees.

k. Recommendation: CJTF-7 and CJTF-180 ensure that standardized policy on interrogation approach techniques are received, understood, trained and enforced by all units.

5. Chapter 5, Other Observations

a. Recommendation: CFLCC, CJTF-7, and CJTF-180 continue to stress the importance of positive unit morale and command climate.

b. Recommendation: TRADOC revise doctrine for the administrative processing of detainees to improve accountability, movement, and disposition in a non-linear battlespace. And further examine processes for capturing and validating lessons learned in order to rapidly modify doctrine and incorporate into training application for Soldiers and units.

- c. Recommendation: The Provost Marshal General revise policy for the administrative processing of detainees to improve accountability, movement, and disposition in a non-linear battlespace.
- d. Recommendation: The Provost Marshal General, in coordination with the G2, update detainee policy to specifically address the administration, internment/resettlement, and intelligence exploitation in a non-linear battlespace, enabling commanders to better manage resources, ensure safe and secure custodial environments, and improve intelligence gathering.
- e. Recommendation: TRADOC and G3 update the Military Police force structure at the division level and below to support the simultaneous execution of detainee operations and other battlefield missions.
- f. Recommendation: TRADOC and G3 update the Military Intelligence force structure at the division level and below to integrate the requirement for detainee operations that allows for timely intelligence exploitation.
- g. Recommendation: TRADOC update doctrine to integrate tactical interrogation at battalion and company level to assist in the intelligence exploitation of detainees immediately upon capture.
- h. Recommendation: CFLCC submit a Request for Forces for the Theater Detainee Reporting Branch Center (TDRC) to meet the requirements for reporting and accountability of detainees and their property.
- i. Recommendation: The Provost Marshal General review the TDRC process, structure, and employment methods for maintaining information on detainees, their property, and other related requirements within an assigned theater of operations and consider the development of an information technology solution.
- j. Recommendation: TRADOC and G3 continue to refine and implement the force structure changes in the Military Intelligence - Counterintelligence/Human Intelligence Force Design Update.
- k. Recommendation: TRADOC integrate the Military Intelligence-Counter Intelligence/Human Intelligence Force Design Updates into the development of Units of Action and Units of Employment.
- l. Recommendation: TRADOC and G3 continue to refine and implement the force structure changes in the Military Police - Internment/Resettlement Battalion Force Design Update.
- m. Recommendation: TRADOC integrate this Force Design Update into the development of Units of Action and Units of Employment.
- n. Recommendation: CJTF-7 and CJTF-180 ensure all units meet the guidelines for minimum infrastructure standards supporting detainee operations to allow for adequate facilities to house detainees.

- o. Recommendation: CJTF-7 and CJTF-180 implement a safety inspection program for all facilities that support detainee operations to identify and eliminate hazards to Soldiers and detainees.
- p. Recommendation: CJTF-7 and CJTF-180 evaluate current living and working conditions at all facilities housing detainees and take corrective actions to improve the current living and working environment.
- q. Recommendation: CJTF-7 review the physical and operations security requirements and policy/doctrinal procedures to ensure units operating internment/resettlement facilities comply with all requirements.
- r. Recommendation: Force Providers require commanders to have trained and equipped field sanitation teams prior to deployment, and deployed commanders ensure field sanitation teams comply with Army policy.
- s. Recommendation: TRADOC review the preventive medicine detachment force structure to ensure support to all collecting points and internment/resettlement facilities in a non-linear battlespace.
- t. Recommendation: MEDCOM train all medical personnel in the preventive medicine aspects of detainee operations to ensure compliance with policy and the laws of land warfare.
- u. Recommendation: MEDCOM ensure all health care personnel are trained on the medical treatment requirements for detainees in accordance with Army Regulations and ensure that units have the required medical equipment and supplies for treating detainees.
- v. Recommendation: CJTF-7 and CJTF-180 evaluate current detainee medical capabilities and requirements and take corrective action to ensure detainees receive the required medical screening and care.
- w. Recommendation: CJTF-7 segregate enemy prisoners of war and civilian internees to ensure compliance with the Geneva Conventions and Army Regulations.
- x. Recommendation: TRADOC identify minimum equipment requirements for detainee operations to ensure successful unit mission accomplishment.
- y. Recommendation: TRADOC establish and identify resource requirements for a standardized "Detainee Field Processing Kit" that will enable capturing units to properly secure and process detainees quickly, efficiently, and safely.
- z. Recommendation: Commanders continue to stress the importance of planning and providing for adequate transportation assets to support continuing detainee operations.
- aa. Recommendation: TRADOC integrate standardized detainee operations training into all Army proponent school common core programs of instruction and training support packages.
- bb. Recommendation: The G3 integrate a prescribed detainee operations training program into unit training.

cc. Recommendation: CFLCC and Force Providers coordinate to ensure, where possible, units are aware of their assigned mission upon mobilization so they can train for their specific mission.

dd. Recommendation: FORSCOM integrate a standardized detainee operations training package as part of pre- and post-mobilization training.

ee. Recommendation: CFLCC ensure that ILO MP units are trained before they assume their ILO MP missions.

ff. Recommendation: The CFLCC contracting officer representative modify the CJTF-7 C2 Interrogation Cell Statement of Work to require civilian interrogators to be former military interrogators trained in current interrogation policy and doctrine or receive formal training in current military interrogation policy and doctrine.

gg. Recommendation: The G3, in coordination with the Office of the Judge Advocate General, mandate that Level B Law of War training have specific learning objectives, be conducted by an instructor/evaluator in a structured manner, and be presented and evaluated annually using the established training conditions and performance standards.

[Next page intentionally left blank]

Appendix A

References

Reference	Date	Title
AR 1-201	12 January 2004	Army Inspection Policy
AR 25-30	16 March 2004	The Army Publishing Program
AR 27-10	6 September 2002	Military Justice
AR 40-5	15 October 1990	Preventive Medicine
AR 71-32	3 March 1997	Force Development and Documentation-Consolidated Policies
AR 190-5	28 August 1992	Evidence Procedures
AR 190-8	1 October 1997	Enemy Prisoners of War, Retained Personnel, Civilian Internees and Other Detainees
AR 190-11	12 February 1998	Physical Security of Arms, Ammunition and Explosives
AR 190-13	30 September 1993	The Army Physical Security Program
AR 190-14	12 March 1993	Carrying of Firearms and Use of Force for Law Enforcement and Security Duties
AR 190-22	1 February 1983	Searches, Seizures, and Disposition of Property
AR 190-40	30 November 1993	Serious Incident Report
AR 190-47	15 August 1996	The Army Corrections System
AR 350-1	9 April 2003	Army Training and Education
AR 381-20	15 November 1993	The Army Counterintelligence Program
AR 385-10	29 February 2000	The Army Safety Program
AR 420-70	10 October 1997	Buildings and Structures
AR 600-20	13 May 2002	Army Command Policy
AR 735-5	10 June 2002	Policies and Procedures for Property Accountability
ARTEP 19-472-MTP	2 March 2001	Mission Training Plan For The Military Police Combat Support And Internment And Resettlement Brigades And Criminal Investigation Division Groups
ARTEP 19-546-30 MTP	10 April 1999	MTP for HHC MP BN (IR)
ARTEP 19-647-30 MTP	10 April 1999	MTP for MP CO (Escort Guard)
ARTEP 19-667-30 MTP	10 April 1999	MTP for MP CO (Guard)
CENTCOM REG 27-13	7 February 1995	Captured Persons Determination of Eligibility For Enemy Prisoner of War Status
CFLCC	18 December 2001	OEF Detainee Handling Guidance
CFLCC FRAGO 254 to OPORD 03-032	111800Z April 2003	Subject is Classified Secret
CFLCC FRAGO 501 to OPORD 03-032	241500Z April 2003	Guidance for the Release and Repatriation of EPW.

CJCSI 3290.01A	15 October 2000	Program For Enemy Prisoners Of War, Retained Personnel, Civilian Internees, And Other Detained Personnel (EPW/Detainee Policy)
CJCSI 5810.01B	25 March 2002	Implementation Of The DoD Law Of War Program
CJCS Message	211933ZJan02	Subject is Classified Secret
CJTF-7 CG Memo	14 September 2003	Subject is Classified Secret
CJTF-7 CG Memo	12 October 2003	Subject is Classified Secret
CJTF-7 CG Memo	13 May 2004	Subject is Classified Secret
CJTF-7 FRAGO 209 to CJTF-7 OPOD 03-036	282021D June 2003	Subject is Classified Secret
CJTF-7 FRAGO 368to CJTF-7 OPOD 03-036	141028Z Jun03	Guidance for the Detention, Handling and Release of Individuals Who are Potentially Subject to Prosecution for War Crimes
CJTF-7 FRAGO 415 to CJTF-7 OPOD 03-036	151950DJul03	Subject is Classified Secret
CJTF-7 FRAGO 455 to CJTF-7 OPOD 03-036	200415DJul03	Classifying and Processing Enemy Prisoners of War/Detained Persons/Civilian Internees
CJTF-7 FRAGO 749 to CJTF-7 OPOD 03-036	242320DAug03	Subject is Classified Secret
CJTF-180 SJA Memo	24 January 2004	CJTF180 Interrogation Techniques
CJTF-180 DCG Memo	16 March 2004	Subject is Classified Secret
CJTF-180 DCG Memo	28 March 2004	Consolidated Detainee Operations Standard Operating Procedures
DA Form 3881	November 1989	Rights Warning Procedure/Waiver Certificate
DA Form 4237-R	August 1985	Detainee Personnel Record
DoD Directive 1325.4	1 December 2003	Confinement of Military Prisoners and Administration of Military Correctional Programs and Facilities
DoD Directive 2310.1	18 August 1994	DoD Program for Enemy Prisoners of War (EPOW) and Other Detainees (Short Title: DoD Enemy POW Detainee Program)
DoD Directive 5100.69	27 December 1972	DoD Program for Prisoners of War and Other Detainees
DoD Directive 5100.77	9 December 1998	DoD Law of War Program
DoD Directive 5210.56	24 January 2002	Use of Deadly Force and the Carrying of Firearms by DoD Personnel Engaged in Law Enforcement and Security Duties
FM 3-0	14 June 2001	Operations
FM 3-31	13 December 2001	Joint Force Land Component Commander Handbook (JFLCC)
FM 3-19.1	31 January 2002	Military Police Operations
FM 3-19.4	4 March 2002	Military Police Leaders' Handbook

FM 3-19.30	8 January 2001	Physical Security
FM 3-19.40	1 August 2001	Military Police Internment/Resettlement Operations
FM 5-34, w/ C3	10 April 2003	Engineer Field Data
FM 6-0	11 August 2003	Mission Command: Command and Control of Army Forces
FM 6-22.5	23 JUNE 2000	Combat Stress
FM 7-0	22 October 2002	Training the Force
FM 22-51	29 September 1994	Leaders' Manual For Combat Stress Control
FM 27-10, w/ C1	15 July 1976	The Law of Land Warfare
FM 27-100	1 March 2000	Legal Support to Operations
FM 34-60	3 October 1995	Counterintelligence
FM 34-52	28 September 1992	Intelligence Interrogation
FORSCOM Message	162313Z Jan 03	Subject is Classified Secret
FORSCOM/ARNG/ USAR Reg 350-2	27 October 1999	Reserve Component Training
FORSCOM Reg 500-3-1	15 April 1998	FORMDEPS, Volume I, FORSCOM Mobilization Plan (FMP)
FORSCOM Reg 500-3-3	15 July 1999	FORMDEPS Volume III, Reserve Component Unit Commander's Handbook (RCUCH)
Geneva Convention	12 August 1949	Relative to the Treatment of POWs
Geneva Convention	12 August 1949	Amelioration of the Condition of the Wounded, Sick and Shipwrecked Members of Armed Forces at Sea
Geneva Convention	12 August 1949	Amelioration of the Condition of the Wounded and Sick in the Armed Forces in the Field
Geneva Convention	12 August 1949	Protection of War Victims
Geneva Convention	12 August 1949	Relative to the Protections of Civilian Persons in Time of War
Geneva Convention	1967	Relative to the Status of Refugees
Geneva Convention	1951	Relative to the Status of Refugees
Convention Against Torture	1984	Convention Against Torture and Other Cruel, Inhuman or Degrading Treatment or Punishment
Hague Convention No. IV	18 October 1907	Respecting the Laws and Customs of War on Land
JP 1-0	19 November 1998	Doctrine for Personnel Support to Joint Operations
JP 1-02	12 April 2001 (amended through 23 March 04)	Department of Defense Dictionary of Military and Associated Terms
JP 2-01	20 November 1996	Joint Intelligence Support to Military Operations
THIS LINE	INTENTIONALLY	LEFT BLANK

Joint Operations Concepts	November 2003	Joint Operations Concepts
MG Antonio Taguba, AR 15-6 Investigation	14 March 2004	AR 15-6, Investigation of the 800th MP BDE
MG Donald J. Ryder, Provost Marshal Report	6 November 2003	Assessment of Detention and Corrections Operations in Iraq
MG Geoffrey D. Miller, CDR JTF-GTMO, Guantanamo Bay, Cuba Report	9 September 2003	Assessment of DoD Counter Terrorism Interrogation and Detention Operations in Iraq
ST 2-22.7	11 April 2002	Tactical Human Intelligence and Counterintelligence Operations
STP 19-95B1-SM	6 August 2002	MOS 95B, Skill Level 1
STP 19-95C14-SM-TG	26 March 1999	MOS 95C, Skill Levels 1/2/3/4
STP 19-95C1-SM	30 September 2003	MOS 95C, Skill Level 1
STP 19-95C24-SM-TG	30 September 2003	MOS 95C, Skill Level 2/3/4
V CORPS FRAGO 006M to V CORPS OPOD 0303-343	190200Z March 2003	Procedures for Handling the Detention of Iraqis in Internment Facilities and Detention Centers
V CORPS FRAGO 312M to V CORPS OPOD FINAL VICTORY	252146D May 2003	Guidance on Tactics, Techniques, and Procedures Designed to Improve the Preservation of Evidence of Crimes Committed by Civilians Detained and Transported to Detention Facilities

APPENDIX B

**Acting Secretary of the Army
Directive for Assessment of Detainee Operations
10 February 2004**

[Next page intentionally left blank]



DEPARTMENT OF THE ARMY
WASHINGTON DC 20310-0200

February 10, 2004

MEMORANDUM FOR THE INSPECTOR GENERAL

SUBJECT: Directive for Assessment of Detainee Operations

You are hereby directed to establish an Assessment Team to complete a Functional Analysis of the Department's internment, enemy prisoner of war, and detention policies, practices, and procedures as the Army executes its role as DOD Executive Agent for Enemy Prisoners of War and Detention Program.

When conducting this assessment, the following terms of reference apply. Use all potential Doctrine, Operations, Training, Materiel, Leadership, Personnel, and Facilities (DOTMLPF) approaches to identify any capability shortfalls with respect to internment, enemy prisoner of war, detention operations, and interrogation procedures and recommend appropriate resolutions or changes if required.

The assessment will focus on the following objectives:

- a. Assess the adequacy of DOTMLPF of Army Forces for internment, enemy prisoner of war, detention operations, and interrogation procedures.
- b. Determine the standards for Army Forces charged with internment, enemy prisoner of war, detention operations and interrogation procedures (e.g., size, equipment, standardization, and training).
- c. Assess current and future organizations and structures for Army Forces responsible for internment, enemy prisoner of war, detention operations and interrogation procedures.
- d. Identify and recommend any changes in policy related to internment, enemy prisoner of war, detention operations and interrogation procedures.

You are authorized to task the Army Staff and subordinate headquarters for those resources needed to ensure accomplishment of the detainee operations assessment. You are further authorized access to locations, documents, and personnel across the Army in order to complete your assessment. Coordinate with other Services for assistance, documentation, and information that may assist in completing this assessment.

You will provide me with a report at the conclusion of the assessment.

800

-2-

This assessment is exempt from the HQDA Short Notice Tasking Policy Message, dated 031353Z Jan 01, requiring units to be notified 180 days from execution of tasking and the HQDA memorandum dated January 27, 2004, subject: Travel [Restriction] to Iraq, Afghanistan, Kuwait and Qatar which requires my approval to travel to these countries.

R. L. Brownlee
Acting Secretary of the Army

Appendix C

Locations Visited**February 2004 (CONUS)**

JRTC MRX (39th Separate Brigade) (Pre-Inspection)
NTC MRX (81st Separate Brigade) (Pre-Inspection)

March 2004 (Afghanistan)

Bagram (CJTF 180 and 237th MP BN)
Khandahar (274th MP CO, 805th MP CO, and 1/10th MTN DIV)
Gheresk (ODA 312)
Khost (1/501st Parachute Infantry Regiment)

March-April 2004 (Iraq)

Baghdad (CJTF 7, Camp Cropper, Camp Slayer, 1st AD Division Collecting Point, 2/1st AD Brigade Collecting Point)
Camp Bucca (160th MP BN)
Abu Ghraib (504th MI BDE)
Ar Ramadi (1/1st ID Brigade Collecting Point)
Brassfield-Mora (2/1st ID Brigade Collecting Point)
Tikrit (1st ID Division Collecting Point)
Mosul (MND-N Collecting Point and 3/2nd ID Brigade Collecting Point, Battalion Collecting Point)

March-April 2004 (Kuwait)

Camp Doha (CFLCC)
Arifjan (2/4th ID)

March-April 2004 (CONUS)

Fort Dix (310th MP BN and 320th MP BN; at two different times)
Fort Hood (4th ID and 720th MP BN)
Fort Bragg (2/82nd ABN DIV and USASOC SERE Course)
Fort Campbell (3/101st ABN DIV)
Fort Meade (HHC 400th MP BDE)
Owings Mill, MD (433rd MP CO)

June 2004 (CONUS)

Fort Leonard Wood (MP School)
Fort Huachuca (MI School)

[Next page intentionally left blank]

Appendix D

Inspection Tools**1. INTERVIEW QUESTIONS:****a. C-4/J-4/G-4**

- 1). Concerning logistical operations, what is your role in the support of (Theater/Division) Detainee Operations?
- 2). Describe priority of support for Detainee Operations. How does this compete with your other mission requirements? Is the Priority of Support in SOPs, OPORDs/FRAGOs?
- 3). Describe how subordinate units plan and procure logistical support for Detainee Operations. (Include: transportation, sundry items, subsistence, organizational, and NBC clothing and equipment items, mail collection and distribution, laundry, and bath equipment) Have you ever coordinated for transportation to evacuate Detainees out of the AOR? Who approved the transfer?
- 4). What are some of the services being contracted out/outsourced to support Detainee Operations in Theater? Are there any issues concerning contracting or budget that you are aware of that impact Detainee Operations? If so, what are they? Who oversees the contracts that support Detainee Operations and where can we find out who the Army Representatives are (CORs)?
- 5). Are you aware of any Home Station Training that subordinate Combat Service Support units conducted prior to deployment to help them prepare for Detainee Operations? (To include collection point activities, etc) Can you describe it?
- 6). Have you had the opportunity to personally visit each of the Internment Facilities to determine if units have the necessary support and supplies to run their facilities? If so, what did you find? How about division and brigade Collection Points?
- 7). What are your challenges/issues in providing daily food rations in sufficient quantity, quality and variety to keep Detainees in good health and IAW with their cultural requirements? What is the schedule for feeding and what are they being fed? Please elaborate
- 8). How do Detainees receive fresh potable water in your area of responsibility? (Bottled water, Lister bags, running water--if so, is it potable)
- 9). What procedures are in place to account for and dispose of captured enemy supplies and equipment?
- 10). What are your biggest issues concerning adequate facilities for Detainees (tents, cots, etc)?
- 11). What are your biggest issues concerning logistical support for Detainee Operations?

12). What do you perceive to be doctrinal logistic shortcomings pertaining to Detainee Operations and how would you fix/incorporate into updated doctrine/accomplish differently? How about Force Structure of logistical units that ensures Detainee Operations can be successfully accomplished? What are the shortcomings and how do we fix at the Army-level?

13). Are you aware of your requirement to report abuse or suspected abuse of detainees?

14). What do you perceive as the mission of your unit? Describe the importance of your role in that mission.

15). Describe your working environment and living conditions since being in Theater.

16). Describe the unit command climate and Soldier morale. Has it changed or evolved since you have been in Theater

17). Are you aware of any incidences of detainee or other abuse in your unit?

18). ADVISEMENT OF RIGHTS (For military personnel)

The text of Article 31 provides as follows a. No person subject to this chapter may compel any person to incriminate himself or to answer any questions the answer to which may tend to incriminate him. b. No person subject to this chapter may interrogate or request any statement from an accused or a person suspected of an offense without first informing him of the nature of the accusation and advising him that he does not have to make any statement regarding the offense of which he is accused or suspected, and that any statement made by him may be used as evidence against him in a trial by court-martial. c. No person subject to this chapter may compel any person to make a statement or produce evidence before any military tribunal if the statement or evidence is not material to the issue and may tend to degrade him. d. No statement obtained from any person in violation of this article, or through the use of coercion, unlawful influence, or unlawful inducement, may be received in evidence against him in a trial by court-martial.

19). I am _____ (grade, if any, and name), a member of the (DAIG). I am part of a team inspecting detainee operations, this is not a criminal investigation. I am reading you your rights because of a statement you made causes me to suspect that you may have committed _____. (specify offense, i.e. aggravated assault, assault, murder). Under Article 31, you have the right to remain silent, that is, say nothing at all. Any statement you make, oral or written, may be used as evidence against you in a trial by courts-martial or in other judicial or administrative proceedings. You have the right to consult a lawyer and to have a lawyer present during this interview. You have the right to military legal counsel free of charge. In addition to military counsel, you are entitled to civilian counsel of your own choosing, at your own expense. You may request a lawyer at any time during this interview. If you decide to answer questions, you may stop the questioning at any time. Do you understand your rights? Do you want a lawyer? (If the answer is yes, cease all questions at this point). Are you willing to answer questions?

20). Describe what you understand happened leading up to and during the incident(s) of abuse.

21). Describe Soldier morale, feelings and emotional state prior to and after these incidents?

22). Was this incident reported to the chain of command? How, when & what was done? What would you have done?

23). How could the incident have been prevented?

24). Describe any unit training or other programs that you are aware of that teach leaders and Soldiers how to recognize and resolve combat stress.

25). What measures are in place to boost morale or to relieve stress

26). What measures could the command enact to improve the morale and command climate of your unit

b. PROVOST MARSHAL

1). What references/standards/publications/SOPs do you use to conduct Detainee Operations?

2). What is the C2 structure/organization of internment facilities across Theater? How many internment facilities under U.S. Military Control, do you oversee? How many divisional Central Collection Points? How about Brigade Forward Collection Points? What MP units in Theater operate internment facilities and where are they positioned? (Battalion and Above) Describe the essential organizational requirements to run an internment facility. (Organizational Elements, Manning, Facilities, Equipment). Do you have what you need to accomplish the mission? If not, explain?

3). How do you ensure the units operating these locations/facilities are complying with the provisions of the Geneva Convention and AR 190-8?

4). Are detainees being employed to work? What are the General policy and procedures for the Employment and Compensation of Detainees?

5). Is there a policy on the ratio of guards to Detainees in Theater? If so, what is it? Is this standard being met? If not, what is the shortfall and how are units meeting the challenge to overcome the shortfall?

6). What is your detainee segregation policy? ((EPWs, Females, Juveniles, Civilian Internees (to include those that are security threats, those that are hostile to coalition forces, and possible HTD/HVD, and Retained Persons, Criminals, etc.)) What can you tell me about the categories of Detainees that you are holding? What are they and what are the definitions of the different categories that your organizations detain? How are you organized to handle the different categories of Detainees (EPW, CI, HVD, OD, and refugees?)

7). What is the minimum living space standard for each Detainee? How is it determined and who set the provisions of minimum living space for internment facilities? (when possible, consult the preventative medicine authority in theater for provisions of minimum living space and sanitary facilities). Has a preventative medicine expert given advice on this?

- 8). Do you use Military Working Dogs (MWD) within internment facilities?
- 9). How does the command ensure that Detainee Operations is conducted in compliance with the international Law of war? (OPORD/FRAGO, ROE, Interrogation Techniques, general orders, humane treatment, etc)
- 10). What is the current policy to grant conditional access to the International Red Cross/Crescent to Detainees? Has this always been the policy? Are they the only NGOs that have conditional access? If not, who are the other organizations?
- 11). What is your responsibility to the National Detainee Reporting Center (NDRC)? What is your relationship with the Theater Detainee Reporting Center (TDRC)? To the best of your knowledge, when were these centers stood up? Describe the Detainee Reporting System? (Software used, Data Base Management, Data Validation, Contingencies, Security and Privacy, etc.) Who has access?
- 12). What are the policies and procedures for US Forces transferring detainees to other Coalition Forces/Host Nation Forces? Has this been done?
- 13). What are the procedures that allow other United States Government Agencies (OGA) access and control to Detainees for the purpose of interrogations? What is the process for transfer and accountability of the Detainee? Does the commander of each internment facility have approval authority to transfer to OGAs? How much notice do they have to provide the chain of command for access or request for transfer? Do the same procedures apply when Military Intelligence personnel request access and control?
- 14). Describe the screening /background checks required prior to hiring interpreters. Are they trusted by U.S. Soldiers?
- 15). What are your biggest issues concerning adequate facilities for Detainees?
- 16). Since you have been in your position, what Detention facilities/locations have you visited and inspected for compliance with law, policy, and regulations? What were the results and findings? Can we get copies of your results?
- 17). What procedures are in place when a detainee in U S custody dies?
- 18). What do you perceive to be doctrinal Military Police shortcomings pertaining to Detainee Operations and how would you fix/incorporate into updated doctrine/accomplish differently? How does your doctrinal law enforcement mission suffer? How about Force Structure of Military Police units that ensures Detainee Operations can be successfully accomplished? What are the shortcomings and how do we fix at the Army-level?
- 19). Are you aware of your requirement to report abuse or suspected abuse of detainees?
- 20). What do you perceive as the mission of your unit? Describe the importance of your role in that mission.
- 21). Describe your working environment and living conditions since being in Theater.

22). Describe the unit command climate and Soldier morale. Has it changed or evolved since you have been in Theater

23). Are you aware of any incidences of detainee or other abuse in your unit?

24). ADVISEMENT OF RIGHTS (For military personnel)

The text of Article 31 provides as follows a. No person subject to this chapter may compel any person to incriminate himself or to answer any questions the answer to which may tend to incriminate him. b. No person subject to this chapter may interrogate or request any statement from an accused or a person suspected of an offense without first informing him of the nature of the accusation and advising him that he does not have to make any statement regarding the offense of which he is accused or suspected, and that any statement made by him may be used as evidence against him in a trial by court-martial. c. No person subject to this chapter may compel any person to make a statement or produce evidence before any military tribunal if the statement or evidence is not material to the issue and may tend to degrade him. d. No statement obtained from any person in violation of this article, or through the use of coercion, unlawful influence, or unlawful inducement, may be received in evidence against him in a trial by court-martial

25). I am _____ (grade, if any, and name), a member of the (DAIG). I am part of a team inspecting detainee operations, this is not a criminal investigation. I am reading you your rights because of a statement you made causes me to suspect that you may have committed _____ (specify offense, i.e. aggravated assault, assault, murder). Under Article 31, you have the right to remain silent, that is, say nothing at all. Any statement you make, oral or written, may be used as evidence against you in a trial by courts-martial or in other judicial or administrative proceedings. You have the right to consult a lawyer and to have a lawyer present during this interview. You have the right to military legal counsel free of charge. In addition to military counsel, you are entitled to civilian counsel of your own choosing, at your own expense. You may request a lawyer at any time during this interview. If you decide to answer questions, you may stop the questioning at any time. Do you understand your rights? Do you want a lawyer? (If the answer is yes, cease all questions at this point). Are you willing to answer questions?

26). Describe what you understand happened leading up to and during the incident(s) of abuse.

27). Describe Soldier morale, feelings and emotional state prior to and after these incidents?

28). Was this incident reported to the chain of command? How, when & what was done? What would you have done?

29). How could the incident have been prevented?

30). Describe any unit training or other programs that you are aware of that teach leaders and Soldiers how to recognize and resolve combat stress.

31). What measures are in place to boost morale or to relieve stress?

32). What measures could the command enact to improve the morale and command climate of your unit?

c. RED CROSS

- 1). Which US Military Controlled Internment Facilities have you visited? What did you find?
- 2). Have you visited any Collection Points in US Army areas? Which ones and what did you find?
- 3). How often are the US Army collection points/internment facilities inspected? What is the make-up of the team? (Prev Med, Doctors, Psychiatrists/Psychologists, etc) What, specifically do you inspect? What do you do with the results of the inspections? Are the appropriate commanders taking the necessary actions to correct the shortcomings noted during your monthly medical inspections? Have you observed any recurring deficiencies during your inspections? Have you noted improvements and if so, what are the improvements? In what areas can we make improvements and what are those?
- 4). How often do you or your staff conduct routine medical inspections (examinations) of detainees under US Military control? What does the medical evaluation consist of? What is the purpose of the medical examination? How are the results recorded/reported?
- 5). Does every US Military Controlled Internment Facility have an infirmary? How adequate is the medical care to the detainees? (Are Retained Persons used?) Do you know of any detainees being denied medical treatment or delayed medical attention? If so, why?
- 6). Do detainees at US Military Controlled Internment Facilities have access to personal hygiene products?
- 7). Have you noticed any markings and/or injuries on a detainee at a US Military Controlled Internment Facility that might lead you to believe the detainee was being abused? Did you bring this to the attention of the Facility Commander? Do you know what he did with the information?
- 8). Are detainees in US Military Controlled Internment Facilities segregated by nationality, language, rank, and sex? Do detainees have the ability to practice their religion? Are detainees able to send and receive mail?
- 9). Can you describe the living conditions at US Military Controlled Internment Facilities? (Sanitary conditions, heat during the winter, shelter for rain, fire prevention measures, latrines, sleep areas, etc)
- 10). How do the detainees get fresh water? What kind of meals are they being fed? Do they get enough food?
- 11). Overall, how do you feel detainees are being treated at US Military Controlled Internment Facilities? What systemic weaknesses have you identified?

d. SJA

- 1). What specific measures has the commander/unit taken to ensure compliance with the Law of War regarding detainee operations? Individual training events? When?

Collective/unit training events? When?

2). What is the minimum standard of treatment that the US must provide any detainee? What policies/procedures do units have in place to support the U. S. General Protection policy relative to the treatment of Detainees in the custody of the U S forces?

3). What specific measures did the unit take prior to arrival in the AOR to ensure that subordinate leaders and soldiers know and understand how to treat, handle, and process detainees properly? Do leaders and Soldiers know and understand how to apply Detainee Operations doctrine and standards when they arrive in the AOR? Can you provide some examples.

4). How is the issue of classification of detainees being handled? Are any Article 5 tribunals being held or is there a presumption that the insurgents clearly do not meet the Article 4 GC III EPW criteria (commanded by a person responsible for his subordinates, wearing fixed distinctive sign, carrying arms openly, conducting operations in accordance with the laws of war)?

5). Did units receive training on the reporting of Detainee abuse? When did this training occur last and how often is it conducted by the units? Are units reporting Detainee abuse? What is happening to individuals who abuse Detainees? How many cases of detainee abuse have you heard of and or processed since you have been in country? At what point in the detention process are most of the abuses occurring? (point of capture, initial collection point, by guards at internment facility, by interrogators)

6). What control measures are units using to maintain detainee discipline and security in each internment facility/collection point?

7). What are the procedures you follow if you personally notice or if it is reported to you that a detainee is injured and you suspect the detainee has been abused? What training has the unit received regarding reporting procedures for detainee abuse?

8). What are the procedures if a detainee in U.S. custody dies?

9). What are the Theater guidelines for any EPW, CI, and RP claims against the U.S. Government?

10). (Internment facility Judge Advocate only) What is the procedure if an EPW or detainee wants to make a complaint or requests to the camp commander regarding conditions of their internment? How are Detainees complaints and requests to the camp commander processed?

11). Have any detainees refused repatriation? If so, what happened to them?

12). What happens when a detainee is suspected of, or is known to have committed a serious offense while they are being interned at either the collection point or detention facility? Describe the due process available to detainees and rights of the detainee suspected of committing a serious offense. Have you or any Staff Judge Advocate provided legal advice to a detainee who might have committed an offense?

13). What is your feeling on how Detainees are being treated? What do you feel is the

primary focus/purpose of detainee operations. (force protection, punishment, rehabilitation, protection, merely a regulatory/legal requirement) No standard. Personnel observations and feelings.

14). What AARs or lessons learned have you written or received regarding detainee operations? Can I get a copy?

15). What do you perceive to be doctrinal legal shortcomings pertaining to Detainee Operations and how would you fix/incorporate into updated doctrine/accomplish differently? How about Force Structure of Staff Judge Advocate to ensure Detainee Operations can be successfully accomplished? What are the shortcomings and how do we fix the problem at the Army-level?

16). What do you perceive as the mission of your unit? Describe the importance of your role in that mission.

17). Describe your working environment and living conditions since being in Theater.

18). Describe the unit command climate and Soldier morale. Has it changed or evolved since you have been in Theater?

19). Are you aware of any incidences of detainee or other abuse in your unit?

20). ADVISEMENT OF RIGHTS (For military personnel)

The text of Article 31 provides as follows a. No person subject to this chapter may compel any person to incriminate himself or to answer any questions the answer to which may tend to incriminate him. b. No person subject to this chapter may interrogate or request any statement from an accused or a person suspected of an offense without first informing him of the nature of the accusation and advising him that he does not have to make any statement regarding the offense of which he is accused or suspected, and that any statement made by him may be used as evidence against him in a trial by court-martial. c. No person subject to this chapter may compel any person to make a statement or produce evidence before any military tribunal if the statement or evidence is not material to the issue and may tend to degrade him. d. No statement obtained from any person in violation of this article, or through the use of coercion, unlawful influence, or unlawful inducement, may be received in evidence against him in a trial by court-martial.

21). I am _____(grade, if any, and name), a member of the (DAIG). I am part of a team inspecting detainee operations, this is not a criminal investigation. I am reading you your rights because of a statement you made causes me to suspect that you may have committed _____ (specify offense, i.e. aggravated assault, assault, murder). Under Article 31, you have the right to remain silent, that is, say nothing at all. Any statement you make, oral or written, may be used as evidence against you in a trial by courts-martial or in other judicial or administrative proceedings. You have the right to consult a lawyer and to have a lawyer present during this interview. You have the right to military legal counsel free of charge. In addition to military counsel, you are entitled to civilian counsel of your own choosing, at your own expense. You may request a lawyer at any time during this interview. If you decide to answer questions, you may stop the questioning at any time. Do you understand your rights? Do you want a lawyer? (If the answer is yes, cease all questions at this point). Are you willing to answer questions?

22). Describe what you understand happened leading up to and during the incident(s) of abuse.

23). Describe Soldier morale, feelings and emotional state prior to and after these incidents?

24). Was this incident reported to the chain of command? How, when & what was done? What would you have done?

25). How could the incident have been prevented?

26). Describe any unit training or other programs that you are aware of that teach leaders and Soldiers how to recognize and resolve combat stress.

27). What measures are in place to boost morale or to relieve stress?

28). What measures could the command enact to improve the morale and command climate of your unit?

e. STAFF ENGINEER (DIVISION & ABOVE)

1). Describe facilities' infrastructure overall that support Detainee Operations. (Sewer, water distribution, storm drainage, electrical distribution, HVAC systems, and lighting, etc.) What are the problems concerning existing facilities and what is being done to fix?

2). What program is in place in Theater that allows for the maintenance and repair of facilities that house Detainees and their supporting facilities?

3). Are the Corps of Engineers involved in any facility upgrades/improvements in Theater for Detainees? If so, what are some ongoing projects? Can I get a list by Project Number? Who is your POC in USACE? What do you know of the Engineer Corps' Theater Construction Management System (TCSM). Were you aware that they have plans, specifications, and materiel requirements for Internment Facilities based on Detainee population?

4). Do you have any knowledge as to why U.S. Forces chose existing facilities rather than to use the Theater Construction Management System (TCSM) and build facilities elsewhere? (How and why were facilities picked as Long Term Detention Facilities?)

5). What is your role in determining provisions of minimum living space for Detention Facilities across the AOR? (when possible, consult the preventative medicine authority in theater for provisions of minimum living space and sanitary facilities). What is the minimum living space standard for each Detainee? Has a preventative medicine expert given advice on this?

6). Do engineer officers train and supervise internal and external labor for Detention Facilities? (construction and repair of detention facilities)? If so, describe the work ((construction, maintenance, repair, and operation of utilities (water, electricity, heat, and sanitation.))

- 7). Are you aware of your requirement to report abuse or suspected abuse of detainees?
- 8). What do you perceive as the mission of your unit? Describe the importance of your role in that mission.
- 9). Describe your working environment and living conditions since being in Theater.
- 10). Describe the unit command climate and Soldier morale. Has it changed or evolved since you have been in Theater?
- 11). Are you aware of any incidences of detainee or other abuse in your unit?
- 12). ADVISEMENT OF RIGHTS (For military personnel)
The text of Article 31 provides as follows a. No person subject to this chapter may compel any person to incriminate himself or to answer any questions the answer to which may tend to incriminate him. b. No person subject to this chapter may interrogate or request any statement from an accused or a person suspected of an offense without first informing him of the nature of the accusation and advising him that he does not have to make any statement regarding the offense of which he is accused or suspected, and that any statement made by him may be used as evidence against him in a trial by court-martial. c. No person subject to this chapter may compel any person to make a statement or produce evidence before any military tribunal if the statement or evidence is not material to the issue and may tend to degrade him. d. No statement obtained from any person in violation of this article, or through the use of coercion, unlawful influence, or unlawful inducement, may be received in evidence against him in a trial by court-martial.
- 13). I am _____(grade, if any, and name), a member of the (DAIG). I am part of a team inspecting detainee operations, this is not a criminal investigation. I am reading you your rights because of a statement you made causes me to suspect that you may have committed _____. (specify offense, i.e. aggravated assault, assault, murder). Under Article 31, you have the right to remain silent, that is, say nothing at all. Any statement you make, oral or written, may be used as evidence against you in a trial by courts-martial or in other judicial or administrative proceedings. You have the right to consult a lawyer and to have a lawyer present during this interview. You have the right to military legal counsel free of charge. In addition to military counsel, you are entitled to civilian counsel of your own choosing, at your own expense. You may request a lawyer at any time during this interview. If you decide to answer questions, you may stop the questioning at any time. Do you understand your rights? Do you want a lawyer? (If the answer is yes, cease all questions at this point). Are you willing to answer questions?
- 14). Describe what you understand happened leading up to and during the incident(s) of abuse.
- 15). Describe Soldier morale, feelings and emotional state prior to and after these incidents
- 16). Was this incident reported to the chain of command? How, when & what was done? What would you have done?
- 17). How could the incident have been prevented?

18). Describe any unit training or other programs that you are aware of that teach leaders and Soldiers how to recognize and resolve combat stress.

19). What measures are in place to boost morale or to relieve stress?

20). What measures could the command enact to improve the morale and command climate of your unit?

f. MI BDE/BN CDR/S-3/CO CDR/1SG

1). (All) What is your overall role in detainee operation process? What involvement do you have in the interrogation process of detainee operations? Do you provide a means to validate detainee's information? Do you provide input as to the disposition of the detainee?

2). (All) What references/standards/publications/SOPs do you use to conduct interrogation Operations?

3). (All) Did your soldiers undergo Level B Law of War training prior to deployment? Explain what training occurred. Is there a plan to train new Soldiers (replacements) to the unit? Did this training include the treatment of Detainees? Explain.

4). (All) What training have you received to ensure your knowledge of DO is IAW the provisions under the Geneva Convention?

5). (All) What Home Station/Mob Site Training did your unit conduct prior to deployment to help your unit prepare for Detainee/interrogation Operations? Describe it. How did the training prepare you to conduct Detainee/interrogation Operations for this deployment? How did this training distinguish between the different categories of Detainees (EPWs, RPs, CIs, etc.)?

6). (All) What training did your unit receive on the established Rules of Engagement (ROE)? How often does this occur? Does this training include Rules of Interaction (ROI)?

7). (All) What procedures are in place to ensure your Soldiers do not violate the rules of engagement for the interment facility/collection point?

8). (All) What guidance or policies are there to ensure fraternization is not taking place between U.S. military personnel and the detainees?

9). (All) How does the command ensure that interrogation Operations is conducted in compliance with the international Law of war? (OPORD/FRAGO, ROE, Interrogation Techniques, general orders, humane treatment, etc)

10). (All) Have you personally visited each of the interrogation Facilities to determine if your unit has the necessary support and supplies to run their facilities? If so, what did you find?

11). (All) What control measures are you using to maintain discipline and security within the interrogation facility?

12). (BN/CO Cdr) Are you receiving sufficient information from the capture paperwork to properly conduct screenings and interrogations? Are the current requirements for documentation of a captured person sufficient or excessive? Did the changes in procedures as far as documenting captured person improve your ability to gather intelligence?

13). (BN/CO Cdr) What are the procedures for the transfer of custody of Detainees from the MP/Guard personnel to Military Intelligence personnel? When the detainee is returned to the guard force, what procedures occur?

14). (CO Cdr/BN S3) Describe the screening /background checks required prior to hiring interpreters. Are they trusted by U.S. Soldiers?

15). (All) Do counterintelligence agents conduct interrogations of detainees? What training have they received for conducting interrogations? What is their understanding of the laws of war as it pertains to interrogating detainees?

16). (All) What do you perceive to be doctrinal shortcomings pertaining to Interrogation Operations? How would you fix/incorporate into updated doctrine/accomplish differently? How about Force Structure to ensure Interrogation Operations can be successfully accomplished? What are the shortcomings and how do we fix the problem at the Army-level?

17). (All) What are the procedures if a detainee in U.S. custody dies?

18). (All) Do you know of the procedures to get stress counseling (Psychiatrist, Chaplain, Medical)? Do your Soldiers know of the procedures to get counseling (Psychiatrist, Chaplain, Medical)?

19). (All) Are you aware of your requirement to report abuse or suspected abuse of detainees?

20). (All) Do your subordinates know the reporting procedures if they observe or become aware of a Detainee being abused?

21). (All) What steps would you take if a subordinate reported to you an incident of alleged Detainee abuse?

22). (All) Do you feel you can freely report an incident of alleged Detainee abuse outside Command channels (IG, CID)

23). (All) What procedures do you have to report suspected detainee abuse (IG, CID, Next Level Commander)

24). (All) What procedures are in place for Detainees to report alleged abuse?

25). (All) What do you perceive as the mission of your unit? Describe the importance of your role in that mission.

26). (All) Describe your working environment and living conditions since being in Theater.

27). (All) Describe the unit command climate and Soldier morale. Has it changed or evolved since you have been in Theater?

28). (All) Are you aware of any incidences of detainee or other abuse in your unit

29). ADVISEMENT OF RIGHTS (For military personnel)

The text of Article 31 provides as follows a. No person subject to this chapter may compel any person to incriminate himself or to answer any questions the answer to which may tend to incriminate him. b. No person subject to this chapter may interrogate or request any statement from an accused or a person suspected of an offense without first informing him of the nature of the accusation and advising him that he does not have to make any statement regarding the offense of which he is accused or suspected, and that any statement made by him may be used as evidence against him in a trial by court-martial. c. No person subject to this chapter may compel any person to make a statement or produce evidence before any military tribunal if the statement or evidence is not material to the issue and may tend to degrade him. d. No statement obtained from any person in violation of this article, or through the use of coercion, unlawful influence, or unlawful inducement, may be received in evidence against him in a trial by court-martial.

30). I am _____(grade, if any, and name), a member of the (DAIG). I am part of a team inspecting detainee operations, this is not a criminal investigation. I am reading you your rights because of a statement you made causes me to suspect that you may have committed _____(specify offense, i.e. aggravated assault, assault, murder). Under Article 31, you have the right to remain silent, that is, say nothing at all. Any statement you make, oral or written, may be used as evidence against you in a trial by courts-martial or in other judicial or administrative proceedings. You have the right to consult a lawyer and to have a lawyer present during this interview. You have the right to military legal counsel free of charge. In addition to military counsel, you are entitled to civilian counsel of your own choosing, at your own expense. You may request a lawyer at any time during this interview. If you decide to answer questions, you may stop the questioning at any time. Do you understand your rights? Do you want a lawyer? (If the answer is yes, cease all questions at this point). Are you willing to answer questions?

31). (All) Describe what you understand happened leading up to and during the incident(s) of abuse.

32). (All) Describe Soldier morale, feelings and emotional state prior to and after these incidents?

33). (All) Was this incident reported to the chain of command? How, when & what was done? What would you have done?

34). (All) How could the incident have been prevented?

35). (All) Describe any unit training or other programs that you are aware of that teach leaders and Soldiers how to recognize and resolve combat stress.

36). (All) What measures are in place to boost morale or to relieve stress?

37). (All) What measures could the command enact to improve the morale and command climate of your unit?

g. MP BDE COMMANDER INTERVIEW QUESTIONS

- 1). What references/standards/publications/SOPs do you require your subordinates to use for Detainee Operations?
- 2). What MP units under your command operate US military controlled Internment Facilities? (Battalion and Company) How many Internment Facilities under U.S. Military Control, do you operate? Where are they positioned across the Theater? Have you visited any of DIV /BDE Collection Points?
- 3). What are the policies on the establishment of Internment facilities? How do you ensure the units are operating these locations/facilities under the provisions of the Geneva Convention and AR 190-8(ROE, Interrogation Techniques, general orders, humane treatment, etc)?
- 4). Are your operations employing detainees for work? If so, what are the General policy and procedures for the Employment and Compensation of Detainees?
- 5). Is there (or do you have) a policy on the ratio of guards to Detainees? If so, what is it? Is this standard being met? If not, what is the shortfall and how are your units managing the challenge?
- 6). What is your detainee segregation policy?
- 7). What is the minimum living space standard for each Detainee? Who set the provisions of minimum living space for Internment Facilities? (when possible, consult the preventative medicine authority in theater for provisions of minimum living space and sanitary facilities). Has a preventative medicine expert given advice on this?
- 8). Are the Corps of Engineers involved in any facility upgrades/improvements in Theater for Detainees? If so, what are some ongoing projects? What do you know of the Engineer Corps' Theater Construction Management System (TCSM). Were you aware that they have plans, specifications, and materiel requirements for Internment Facilities based on Detainee population?
- 9). Do you use Military Working Dogs (MWD) within detention facilities?
- 10). What is the current policy to grant conditional access to the International Red Cross/Crescent to Detainees? Has this always been the policy? Are they the only NGOs that have conditional access? If not, who are the other organizations?
- 11). Explain how medical information is kept on each individual Detainee?
- 12). What is your responsibility to the National Detainee Reporting Center (NDRC)? What is your relationship with the Theater Detainee Reporting Center (TDRC)? To the best of your knowledge, when were these centers stood up? Describe the Detainee Reporting System? (Software used, Data Base Management, Data Validation, Contingencies, Security and Privacy, etc.) Who has access?
- 13). When are Detainees assigned Internment Serial Numbers (ISNs) (from point of capture to internment? Are there any reasons why Detainees would not be assigned ISNs?

14). What are the policies and procedures for US Forces transferring detainees to other Coalition Forces/Host Nation Forces? Has this been done?

15). What are the procedures that allow other United States Government Agencies (OGA) access to Detainees? Who is the approval authority? How much notice do they have to provide the chain of command? Do Detainees ever leave U.S. Military Control for interrogation? How about U.S. Military Police control to MI control? What is the process for turnover and accountability of the Detainee? What happens if a detainee is returned to U.S. Military Control from an OGA, and it is determined that abuse has occurred?

16). How are interpreters (linguists/translators) integrated within the Detainee Detention system (within each facility)?

17). What are your biggest issues concerning logistical, contractor, and interpreter support for Detainee Operations?

18). What are your biggest issues concerning adequate facilities for Detainees?

19). Can you describe the in-processing actions required for Detainees? What are some of the reasons that Detainees are not accepted to the internment facility? Are capturing units/subordinate units properly processing Detainees? If not, what are they doing wrong? Is it administrative in nature or in the physically handling of Detainees?

20). What is the process to account for and dispose of weapons and contraband confiscated from Detainees? What happens to personal property? (Is it disposed of/tagged along with the Detainee and is it stored properly and accounted for?) Why is the DD Form 2745 (Capture Tag) not being used? What are units using in lieu of (if any)? ((Detainee Capture Card found in draft MTTP, Detainee Ops—this card does not require near as much data as DD 2745 (. The CPA Apprehension Form helps offset the lack of info on the Detainee, however it is usually filled out in a single copy (not the 3 required))) Who decided on the use of the Coalition Provisional Authority Apprehension Form and why?

21). Does the current force structure meet the requirements to run Internment Facilities? If not why? What recommendations can you can you provide? Do your units have what they need to accomplish the mission (personnel/equipment) without additional support? If not, explain? What do you perceive to be doctrinal shortcomings pertaining to Detainee Operations and how would you fix/incorporate into updated doctrine and accomplish differently?

22). What is the ROE concerning Detainees? How do you ensure that this ROE is being followed and understood by all Soldiers in your command that have any contact with Detainees? What is the policy to train on the established Rules of Engagement (ROE)? How often does this occur? Does this training include Rules of Interaction (ROI)?

23). What procedures are in place when a detainee in U S custody dies?

24). What are the procedures for repatriation?

25). What religious activities are permitted?

26). Are you aware of your requirement to report abuse or suspected abuse of detainees?

27). Do your subordinates know the reporting procedures if they observe or become aware of a Detainee being abused?

28). What steps would you take if a subordinate reported to you an incident of alleged Detainee abuse?

29). Do you feel you can freely report an incident of alleged Detainee abuse outside Command channels (IG, CID)?

30). What procedures do you have to report suspected detainee abuse (IG, CID, Next Level Commander)?

31). What procedures are in place for Detainees to report alleged abuse?

32). What do you perceive as the mission of your unit? Describe the importance of your role in that mission.

33). Describe your working environment and living conditions since being in Theater.

34). Describe the unit command climate and Soldier morale. Has it changed or evolved since you have been in Theater?

35). Are you aware of any incidences of detainee or other abuse in your unit?

36). ADVISEMENT OF RIGHTS (For military personnel)

The text of Article 31 provides as follows a. No person subject to this chapter may compel any person to incriminate himself or to answer any questions the answer to which may tend to incriminate him. b. No person subject to this chapter may interrogate or request any statement from an accused or a person suspected of an offense without first informing him of the nature of the accusation and advising him that he does not have to make any statement regarding the offense of which he is accused or suspected, and that any statement made by him may be used as evidence against him in a trial by court-martial. c. No person subject to this chapter may compel any person to make a statement or produce evidence before any military tribunal if the statement or evidence is not material to the issue and may tend to degrade him. d. No statement obtained from any person in violation of this article, or through the use of coercion, unlawful influence, or unlawful inducement, may be received in evidence against him in a trial by court-martial.

37). I am _____(grade, if any, and name), a member of the (DAIG). I am part of a team inspecting detainee operations, this is not a criminal investigation. I am reading you your rights because of a statement you made causes me to suspect that you may have committed _____. (specify offense, i.e. aggravated assault, assault, murder). Under Article 31, you have the right to remain silent, that is, say nothing at all. Any statement you make, oral or written, may be used as evidence against you in a trial by courts-martial or in other judicial or administrative proceedings. You have the right to consult a lawyer and to have a lawyer present during this interview. You have the right to military legal counsel free of charge. In addition to military counsel, you are entitled to civilian counsel of your own choosing, at your own expense. You may request a lawyer at any time during this interview. If you decide to answer questions, you may stop the questioning at any time. Do you understand your rights? Do you want a

lawyer? (If the answer is yes, cease all questions at this point). Are you willing to answer questions?

38). Describe what you understand happened leading up to and during the incident(s) of abuse.

39). Describe Soldier morale, feelings and emotional state prior to and after these incidents?

40). Was this incident reported to the chain of command? How, when & what was done? What would you have done?

41). How could the incident have been prevented?

42). Describe any unit training or other programs that you are aware of that teach leaders and Soldiers how to recognize and resolve combat stress.

43). What measures are in place to boost morale or to relieve stress

44). What measures could the command enact to improve the morale and command climate of your unit?

h. CDR/OIC & SGM/NCOIC INTERNMENT FACILITY

1). Can you tell me what basic publications you use for Detainee Operations (doctrine and standards)?

2). What standards were used in establishing this facility?

3). What procedures do you have in place to ensure Soldiers and leaders understand the use of force and rules of engagement for the interment facility?

4). How did you prepare yourself and your junior leaders to become familiar with and understand the applicable regulations, OPORDS/FRAGOs, directives, international laws and administrative procedures to operate an I/R facility?

5). How did Home Station/Mob Site Training prepare you to conduct Detainee Operations at this facility? What training have you and your Soldiers received to ensure your knowledge of DO is IAW the Geneva Convention and DoD/Army policy? (Did this include Law of War and treatment of Detainees training.)?

6). Describe the training the guard force received to prepare them for their duties.

7). How does your unit conduct sustainment training for Detainee Operations or training for newly assigned personnel? When did your unit last conduct this training?

8). Describe some of the basic operations of the camp relating to detainee segregation, captured medical/religious personnel, feeding, sanitation, etc? Where do you maintain copies of the Geneva Convention around the facility? (Is it posted in the detainee's home language within the facilities)? Are camps segregating Detainees by nationality, language, rank, and sex? How are captured Medical personnel and Chaplains being used in the camps?

What provisions are in place for the receipt and distribution of Detainee correspondence/mail? Are the daily food rations sufficient in quantity or quality and variety to keep detainees in good health? Are personal hygiene items and needed clothing being supplied to the Detainees? Are the conditions within the camp sanitary enough to ensure a clean and healthy environment free from disease and epidemics? Is there an infirmary located within the camp?

9). How are you organized to handle the different categories of personnel (EPW, CI, OD, females, JVs, and refugees)? How about female Detainees? How and where do you house them? Do you maintain a separate site for sick or wounded Detainees? If so where is it and how does your unit maintain the security and safeguarding of Detainees there?

10). Describe the procedures you use when you inprocess a detainee. (CPA Forces Apprehension Form, two sworn statements, EPW tag, where do you store Detainees' confiscated personal affects (if any) and how are they accounted for (are they tagged with DD Form 2745)? How is evidence tagged? What procedures are in place to dispose of captured enemy supplies and equipment?) How is the transfer of Detainees handled between different services and Other Governmental Organizations?

11). Where do you store Detainees' confiscated personal affects (if any) and how are they accounted for? (Are they tagged with DD Form 2745)?

12). What are the procedures for the interrogation/questioning of Detainees?

13). What are the procedures for the transfer of custody of Detainees from the MP/Guard personnel to Military Intelligence personnel? When the detainee is returned to the guard force, what procedures occur? (what info is passed on to the Guard Force (type of reward?)?...Observation report, paper trail audit)

14). What control measures do you use to maintain discipline and security in the facility?

15). What MP units (guards, escort, detachments) do you have at your disposal to operate and maintain this internment facility? Do you have any shortages? How do these shortages impact your mission? What non-MP units are you using to help operate this facility? Do you have any shortages? How do these shortages impact your mission?

16). What kind of security lighting do you have that ensures you have a safe and secure operation at night? How do you provide heat to detainees during the winter? What fire prevention/safety measures do you have?

17). Are you employing detainees for work? What are the General policy and procedures for the Employment and Compensation of Detainees?

18). What type of Medical assets are present in support of medical treatment of detainees?

19). What kind of stress counseling do you provide to Soldiers/Guards?

20). Are Detainees allowed to practice their religion? Is there a chaplain available to minister to the detainees? Is the chaplain a Retained Personnel, US Forces, or a civilian?

21). Describe the latrine facilities for Detainees' use (do they have access to it day and night and does it conform to the rules of hygiene and do females have separate facilities). How are they cleaned and how often and by whom? Where do they bathe and conduct other personal hygiene (this will depend how long it takes to evacuate Detainees to U.S. Military Controlled Detention Facilities--12 hours is the standard)?

22). Describe how the unit plans and procures logistical support to include: transportation, subsistence, organizational, and NBC clothing and equipment items, mail collection and distribution, laundry, and bath equipment ISO DO. What logistical support do you receive to run this Facility? What types of supplies is greater in-demand for the unit during detainee operations? What are your shortfalls?

23). How do the Detainees receive fresh water (Bottled water or Lister bag)?

24). What personnel or equipment USR shortages are affecting your ability to perform detainee operations?

25). What do you perceive to be doctrinal shortcomings pertaining to Detainee Operations and how would you fix/incorporate into updated doctrine/accomplish differently? How about Force Structure to ensure Detainee Operations can be successfully accomplished? What are the shortcomings and how do we fix the problem at the Army-level?

26). What are the procedures if an EPW or RP in U.S. custody dies?

27). What AARs or lessons learned have you written or received regarding detainee operations? Can I get a copy?

28). Are you aware of your requirement to report abuse or suspected abuse of detainees?

29). Do your subordinates know the reporting procedures if they observe or become aware of a Detainee being abused?

30). What steps would you take if a subordinate reported to you an incident of alleged Detainee abuse?

31). Do you feel you can freely report an incident of alleged Detainee abuse outside Command channels (IG, CID)?

32). What procedures do you have to report suspected detainee abuse (IG, CID, Next Level Commander)?

33). What procedures are in place for Detainees to report alleged abuse?

34). What do you perceive as the mission of your unit? Describe the importance of your role in that mission.

35). Describe your working environment and living conditions since being in Theater.

36). Describe the unit command climate and Soldier morale. Has it changed or evolved since you have been in Theater?

37). Are you aware of any incidences of detainee or other abuse in your unit?

38). **ADVISEMENT OF RIGHTS (For military personnel)**

The text of Article 31 provides as follows a. No person subject to this chapter may compel any person to incriminate himself or to answer any questions the answer to which may tend to incriminate him. b. No person subject to this chapter may interrogate or request any statement from an accused or a person suspected of an offense without first informing him of the nature of the accusation and advising him that he does not have to make any statement regarding the offense of which he is accused or suspected, and that any statement made by him may be used as evidence against him in a trial by court-martial. c. No person subject to this chapter may compel any person to make a statement or produce evidence before any military tribunal if the statement or evidence is not material to the issue and may tend to degrade him. d. No statement obtained from any person in violation of this article, or through the use of coercion, unlawful influence, or unlawful inducement, may be received in evidence against him in a trial by court-martial.

39). I am _____(grade, if any, and name), a member of the (DAIG). I am part of a team inspecting detainee operations, this is not a criminal investigation. I am reading you your rights because of a statement you made causes me to suspect that you may have committed _____ (specify offense, i.e. aggravated assault, assault, murder). Under Article 31, you have the right to remain silent, that is, say nothing at all. Any statement you make, oral or written, may be used as evidence against you in a trial by courts-martial or in other judicial or administrative proceedings. You have the right to consult a lawyer and to have a lawyer present during this interview. You have the right to military legal counsel free of charge. In addition to military counsel, you are entitled to civilian counsel of your own choosing, at your own expense. You may request a lawyer at any time during this interview. If you decide to answer questions, you may stop the questioning at any time. Do you understand your rights? Do you want a lawyer? (If the answer is yes, cease all questions at this point). Are you willing to answer questions?

40). Describe what you understand happened leading up to and during the incident(s) of abuse.

41). Describe Soldier morale, feelings and emotional state prior to and after these incidents?

42). Was this incident reported to the chain of command? How, when & what was done? What would you have done?

43). How could the incident have been prevented?

44). Describe any unit training or other programs that you are aware of that teach leaders and Soldiers how to recognize and resolve combat stress.

45). What measures are in place to boost morale or to relieve stress?

46). What measures could the command enact to improve the morale and command climate of your unit?

i. MANEUVER BDE/BN XO

1). What are your responsibilities concerning detainee operations?

- 2). (BDE XO) What are your responsibilities concerning the Forward Collection Point in the BSA? What is your relationship with the Forward Collection Point OIC?
- 3). Can you tell me what basic publications you use for Detainee Operations?
- 4). How did you prepare yourself and your junior leaders to become familiar with and understand the applicable regulations, OPORDS/FRAGOs directives, international laws and administrative procedures to support Detainee Operations?
- 5). How did Home Station/Mob Site Training prepare you to conduct Detainee Operations?
- 6). Can you describe the process of getting a Detainee to the Forward Collection Point in the BSA beginning with the point of Capture? How long do detainees stay in the company holding area before being transported to the BDE Forward Collection Point?
- 7). (BN XO) How do your companies integrate the security and defense of the company holding areas into their perimeter defense? What is your normal ratio of guards to detainees in the holding area? Is this ratio the proper mix for you to perform your mission? If not, what are the shortfalls? How do these shortfalls impact your mission
- 8). Are you experiencing any transportation problems to move detainees, and if so what? What is the number of personnel needed to move prisoners internally or externally (i.e. from the BN holding areas to the Forward Collection Point, for medical evacuation, etc?)
- 9). What personnel or equipment USR shortages are affecting your ability to support detainee operations? What are your resource shortfalls to support this operation? What types of supplies are greater in-demand for the unit during detainee operations?
- 10). What do you perceive to be doctrinal shortcomings pertaining to Detainee Operations and how would you fix/incorporate into updated doctrine/accomplish differently? How about Force Structure to ensure Detainee Operations can be successfully accomplished? What are the shortcomings and how do we fix the problem at the Army-level?
- 11). What procedures are in place to ensure Soldiers and leaders understand the use of force and rules of engagement?
- 12). What kind of stress counseling are Soldiers/Guards provided?

- 13). What are the procedures for evacuating a sick or wounded Detainee? How does your unit maintain the security and safeguarding of sick or wounded Detainees while in transport?
- 14). Describe how the unit plans and procures logistical support to include: subsistence, organizational, and NBC clothing and equipment items, mail collection and distribution, laundry, and bath equipment ISO DO.
- 15). (BN XO) How do you provide your unit holding area with water? (Bottled water or bulk water)?
- 16). What are the procedures if a detainee in U.S. custody dies?
- 17). What AARs or lessons learned have you written or received regarding detainee operations? Can I get a copy?
- 18). Are you aware of your requirement to report abuse or suspected abuse of detainees?
- 19). What procedures do you have to report suspected detainee abuse? Who can you report abuse/suspected abuse to?
- 20). Do your subordinates know the reporting procedures if they observe or become aware of a Detainee being abused?
- 21). What steps would you take if a subordinate reported to you an incident of alleged Detainee abuse?
- 22). What do you perceive as the mission of your unit? Describe the importance of your role in that mission.
- 23). Describe your working environment and living conditions since being in Theater.
- 24). Describe the unit command climate and Soldier morale. Has it changed or evolved since you have been in Theater?
- 25). Are you aware of any incidences of detainee or other abuse in your unit?
- 26). ADVISEMENT OF RIGHTS (For military personnel)
 The text of Article 31 provides as follows a. No person subject to this chapter may compel any person to incriminate himself or to answer any questions the answer to which may tend to incriminate him. b. No person subject to this chapter may interrogate or request any statement from an accused or a person suspected of an offense without first informing him of the nature of the accusation and advising him that he does not have to make any statement regarding the offense of which he is accused or suspected, and that any statement made by him may be used as evidence against him in a trial by court-martial. c. No person subject to this chapter may compel any person to make a statement or produce evidence before any military tribunal if the statement or evidence is not material to the issue and may tend to degrade him. d. No statement obtained from any person in violation of this article, or through the use of coercion, unlawful influence, or unlawful inducement, may be received in evidence against him in a trial by court-martial.

27). I am _____(grade, if any, and name), a member of the (DAIG). I am part of a team inspecting detainee operations, this is not a criminal investigation. I am reading your rights because of a statement you made causes me to suspect that you may have committed _____ (specify offense, i.e. aggravated assault, assault, murder). Under Article 31, you have the right to remain silent, that is, say nothing at all. Any statement you make, oral or written, may be used as evidence against you in a trial by courts-martial or in other judicial or administrative proceedings. You have the right to consult a lawyer and to have a lawyer present during this interview. You have the right to military legal counsel free of charge. In addition to military counsel, you are entitled to civilian counsel of your own choosing, at your own expense. You may request a lawyer at any time during this interview. If you decide to answer questions, you may stop the questioning at any time. Do you understand your rights? Do you want a lawyer? (If the answer is yes, cease all questions at this point). Are you willing to answer questions?

28). Describe what you understand happened leading up to and during the incident(s) of abuse.

29). Describe Soldier morale, feelings and emotional state prior to and after these incidents?

30). Was this incident reported to the chain of command? How, when & what was done? What would you have done?

31). How could the incident have been prevented?

32). Describe any unit training or other programs that you are aware of that teach leaders and Soldiers how to recognize and resolve combat stress.

33). What measures are in place to boost morale or to relieve stress?

34). What measures could the command enact to improve the morale and command climate of your unit?

j. OIC & NCOIC COLLECTION POINT

1). Can you tell me what sources that you use to get policy, doctrine and standards for Detainee Operations? (What doctrine was used in setting up the collection point?) Describe the basic principles of detainee operations and how you are applying them.

2). How did you prepare yourself and your junior leaders/Soldiers to understand applicable regulations, OPORD/FRAGO, directives, international laws and administrative procedures to operate a collection Point?

3). How did Home Station/Mob Site Training prepare you to conduct Detainee Operations? (Did this include Law of War and treatment of Detainees training.)?

4). Describe the training the guard force received to prepare them for their duties.

- 5). How does your unit conduct sustainment training for Detainee Operations or training for newly assigned personnel? (How often does this occur and please describe it?) When did your unit last conduct this training?
- 6). What kind of security lighting do you have that ensures you have a safe and secure operation at night? How do you provide heat to detainees during the winter? What fire prevention/safety measures do you have?
- 7). In relation to where the detainees are housed, how far away are your ammunition and fuel storage sites? Where is your screening site where MI Soldiers interrogate Detainees?
- 8). Describe some of the basic operations of the collection point relating to detainee segregation, captured medical/religious personnel, feeding, sanitation, etc? (Do you segregate Detainees by nationality, language, religion, rank, and sex? How are captured Medical personnel and Chaplains being used? Are the daily food rations sufficient in quantity or quality and variety to keep detainees in good health? Are personal hygiene items and needed clothing being supplied to the Detainees? Are the conditions within the collection point sanitary enough to ensure a clean and healthy environment free from disease and epidemics?)
- 9). What control measures do you use to maintain detainee discipline and security in the collection point?
- 10). What are the procedures for the transfer of Detainees from the collection points to US Military controlled detention facilities? How is the transfer of Detainees handled between coalition forces/host nation?
- 11). What transportation problems do you experience moving detainees during the operation?
- 12). Describe the procedures you use when you in process a detainee. (CPA Forces Apprehension Form, two sworn statements, EPW tag, where do you store Detainees' confiscated personal affects (if any) and how are they accounted for (are they tagged with DD Form 2745)? How is evidence tagged? What procedures are in place to dispose of captured enemy supplies and equipment? Do you medically screen detainees?)
- 13). What MP units (platoon, guards, escort, detachments) do you have at your disposal to operate and maintain the collection point? Do you have any shortages? How do these shortages impact your mission? What non-MP units are you using to help operate the collection point? Do you have any shortages? How do these shortages impact your mission?
- 14). What is your normal ratio of guards to detainees in the collection point? Is this ratio the proper mix for you to perform your mission? If not, what are the shortfalls? Why are their shortfalls? How do these shortfalls impact your mission?
- 15). What is the number of personnel that is needed to move prisoners internally and externally (i.e. to the internment facility, from the BN Collection Points, for medical, evacuation, etc
- 16). What personnel shortages do you have? What issues, if any, do you feel your unit has regarding manning or personnel resourcing in conducting Detention Operations?

17). What equipment shortages (USR) are affecting your ability to perform detainee operations? What other equipment is the unit experiencing as a shortfall concerning detainee operations, (i.e., restraints, uniforms, CIF items, weapons, etc.)? What major shortfalls has the unit encountered in regards to materiel and supply distribution?

18). Describe how the unit plans and procures logistical support to include: transportation, subsistence, organizational, and NBC clothing and equipment items, mail collection and distribution, laundry, and bath equipment ISO DO.

19). What logistical support do you receive to run this Facility? What types of supplies is greater in-demand for the unit during detainee operations? And are these items regularly filled?

20). What procedures do you have in place to ensure Soldiers and leaders understand the use of force and rules of engagement for the collection point?

21). What are the unit's procedures for the interrogation/questioning of Detainees?

22). What kind of stress counseling are Soldiers/Guards provided?

23). Do you maintain a separate site for sick or wounded Detainees? If so where is it and how does your unit maintain the security and safeguarding of Detainees there? How about female Detainees? How and where do you house them?

24). What type of Medical personnel/units are available in support of medical treatment of detainees?

25). Are Detainees given the latitude to practice their religion? Is there a chaplain available to minister to the detainees? Is the chaplain a Retained Personnel, US Forces, or a civilian?

26). Describe the latrine facilities for Detainees' use (do they have access to it day and night and does it conform to the rules of hygiene and do females have separate facilities). How are they cleaned and how often and by whom? Where do they bathe and conduct other personal hygiene (this will depend how long it takes to evacuate Detainees to U.S. Military Controlled Detention Facilities--12 hours is the standard)?

27). How do the Detainees receive fresh water (Bottled water or Lister bag)?

28). What are the procedures if a detainee in U.S. custody dies?

29). What AARs or lessons learned have you written or received regarding detainee operations? Can I get a copy?

30). Are you aware of your requirement to report abuse or suspected abuse of detainees?

31). Do your subordinates know the reporting procedures if they observe or become aware of a Detainee being abused?

32). What steps would you take if a subordinate reported to you an incident of alleged Detainee abuse?

33). Do you feel you can freely report an incident of alleged Detainee abuse outside Command channels (IG, CID)?

34). What procedures do you have to report suspected detainee abuse (IG, CID, Next Level Commander)?

35). What systems are in place for detainees to report alleged abuse?

36). What do you perceive as the mission of your unit? Describe the importance of your role in that mission.

37). Describe your working environment and living conditions since being in Theater.

38). Describe the unit command climate and Soldier morale. Has it changed or evolved since you have been in Theater?

39). Are you aware of any incidences of detainee or other abuse in your unit?

40). ADVISEMENT OF RIGHTS (For military personnel)

The text of Article 31 provides as follows a. No person subject to this chapter may compel any person to incriminate himself or to answer any questions the answer to which may tend to incriminate him. b. No person subject to this chapter may interrogate or request any statement from an accused or a person suspected of an offense without first informing him of the nature of the accusation and advising him that he does not have to make any statement regarding the offense of which he is accused or suspected, and that any statement made by him may be used as evidence against him in a trial by court-martial. c. No person subject to this chapter may compel any person to make a statement or produce evidence before any military tribunal if the statement or evidence is not material to the issue and may tend to degrade him. d. No statement obtained from any person in violation of this article, or through the use of coercion, unlawful influence, or unlawful inducement, may be received in evidence against him in a trial by court-martial.

41). I am _____(grade, if any, and name), a member of the (DAIG). I am part of a team inspecting detainee operations, this is not a criminal investigation. I am reading you your rights because of a statement you made causes me to suspect that you may have committed _____ (specify offense, i.e. aggravated assault, assault, murder). Under Article 31, you have the right to remain silent, that is, say nothing at all. Any statement you make, oral or written, may be used as evidence against you in a trial by courts-martial or in other judicial or administrative proceedings. You have the right to consult a lawyer and to have a lawyer present during this interview. You have the right to military legal counsel free of charge. In addition to military counsel, you are entitled to civilian counsel of your own choosing, at your own expense. You may request a lawyer at any time during this interview. If you decide to answer questions, you may stop the questioning at any time. Do you understand your rights? Do you want a lawyer? (If the answer is yes, cease all questions at this point). Are you willing to answer questions?

42). Describe what you understand happened leading up to and during the incident(s) of abuse.

43). Describe Soldier morale, feelings and emotional state prior to and after these incidents?

44). Was this incident reported to the chain of command? How, when & what was done? What would you have done?

45). How could the incident have been prevented?

46). Describe any unit training or other programs that you are aware of that teach leaders and Soldiers how to recognize and resolve combat stress.

47). What measures are in place to boost morale or to relieve stress?

48). What measures could the command enact to improve the morale and command climate of your unit?

k. INTERROGATOR OIC/NCOIC

1). What references/standards/publications/SOPs do you use to conduct interrogation Operations?

2). How does the command ensure that interrogation Operations is conducted in compliance with the international Law of war? (OPORD/FRAGO, ROE, Interrogation Techniques, general orders, humane treatment, etc)

3). Did you and your soldiers undergo Level B Law of War training prior to deployment? Explain what training occurred. Is there a plan to train new Soldiers (replacements) to the unit? Did this training include the treatment of Detainees? Explain.

4). What Home Station/Mob Site Training did you and your soldiers receive prior to deployment to help your unit prepare for Detainee/interrogation Operations? Describe it. How did the training prepare you to conduct Detainee/interrogation Operations for this deployment? How did this training distinguish between the different categories of Detainees (EPWs, RPs, CIs, etc.)?

5). What training did you receive on the established Rules of Engagement (ROE)? How often does this occur? Does this training include Rules of Interaction (ROI)?

6). What procedures are in place to ensure your Soldiers do not violate the rules of engagement for the internment facility/collection point?

7). What guidance or policies are there to ensure fraternization is not taking place between U.S. military personnel and the detainees?

8). What training have you and your subordinates received to ensure your knowledge of DO is IAW the provisions under the Geneva Convention?

9). What is the OIC/NCOICs overall role in detainee operation process? What involvement do the OIC/NCOICs have in the interrogation process of detainee operations? Do

the OIC/NCOICs provide a means to validate detainee's information? Do the OIC/NCOICs provide input as to the disposition of the detainee?

10). Where are your screening sites located (where detainees are interrogated and screened)? Are these facilities adequate for your needs? Do you have enough interrogators for your operation needs? What are your personnel shortfalls?

11). What is the procedure on how to identify a detainee who may have intelligence information? Who performs this procedure? Are MPs involved in the decision-making? Are PIRs used as a basis for the identification of detainees of interest, personality lists used, etc?

12). Have you personally observed the interrogation operations at this Facility to determine if your unit has the necessary support and supplies to run the facilities? If so, what did you find?

13). What control measures are you using to maintain discipline and security within the interrogation facility?

14). How many people are authorized to be present in the room when interrogating/screening a detainee? Under what circumstances are you required and authorized to have more people?

15). Are the personal effects of a detainee released to the interrogator or is the interrogator allowed to examine the items?

16). Are you receiving sufficient information from the capture paperwork to properly conduct screenings and interrogations? Are the current requirements for documentation of a captured person sufficient or excessive? Did the changes in procedures as far as documenting captured person improve your ability to gather intelligence?

17). What are the procedures for the transfer of custody of Detainees from the MP/Guard personnel to Military Intelligence personnel? When the detainee is returned to the guard force, what procedures occur?

18). Describe the screening /background checks required prior to hiring interpreters. Are they trusted by U.S. Soldiers?

19). What is your perception of the contract interrogators training and capabilities to conduct proper interrogations of detainees?

20). How are translators/linguists used during the screening/interrogation process? Do you trust the interpreter? How are MPs/Guards used during this process?

21). Do counterintelligence agents conduct interrogations of detainees? What training have they received for conducting interrogations? What is their understanding of the laws of war as it pertains to interrogating detainees?

22). What do you perceive to be doctrinal shortcomings pertaining to Interrogation Operations? How would you fix/incorporate into updated doctrine/accomplish differently? How about Force Structure to ensure Interrogation Operations can be successfully accomplished? What are the shortcomings and how do we fix the problem at the Army-level?

- 23). What are the procedures if a detainee in U.S. custody dies?
- 24). Do you know of the procedures to get stress counseling (Psychiatrist, Chaplain, Medical)? Do your Soldiers know of the procedures to get counseling (Psychiatrist, Chaplain, Medical)?
- 25). Are you aware of your requirement to report abuse or suspected abuse of detainees?
- 26). Do your subordinates know the reporting procedures if they observe or become aware of a Detainee being abused?
- 27). What steps would you take if a subordinate reported to you an incident of alleged Detainee abuse?
- 28). Do you feel you can freely report an incident of alleged Detainee abuse outside Command channels (IG, CID)?
- 29). What procedures do you have to report suspected detainee abuse (IG, CID, Next Level Commander)?
- 30). What procedures are in place for Detainees to report alleged abuse?
- 31). What do you perceive as the mission of your unit? Describe the importance of your role in that mission.
- 32). Describe your working environment and living conditions since being in Theater.
- 33). Describe the unit command climate and Soldier morale. Has it changed or evolved since you have been in Theater?
- 34). Are you aware of any incidences of detainee or other abuse in your unit?
- 35). ADVISEMENT OF RIGHTS (For military personnel)
 The text of Article 31 provides as follows a. No person subject to this chapter may compel any person to incriminate himself or to answer any questions the answer to which may tend to incriminate him. b. No person subject to this chapter may interrogate or request any statement from an accused or a person suspected of an offense without first informing him of the nature of the accusation and advising him that he does not have to make any statement regarding the offense of which he is accused or suspected, and that any statement made by him may be used as evidence against him in a trial by court-martial. c. No person subject to this chapter may compel any person to make a statement or produce evidence before any military tribunal if the statement or evidence is not material to the issue and may tend to degrade him. d. No statement obtained from any person in violation of this article, or through the use of coercion, unlawful influence, or unlawful inducement, may be received in evidence against him in a trial by court-martial.
- 36). I am _____(grade, if any, and name), a member of the (DAIG). I am part of a team inspecting detainee operations, this is not a criminal investigation. I am reading you your rights because of a statement you made causes me to suspect that you may have committed _____ (specify offense, i.e. aggravated assault, assault, murder). Under Article

31, you have the right to remain silent, that is, say nothing at all. Any statement you make, oral or written, may be used as evidence against you in a trial by courts-martial or in other judicial or administrative proceedings. You have the right to consult a lawyer and to have a lawyer present during this interview. You have the right to military legal counsel free of charge. In addition to military counsel, you are entitled to civilian counsel of your own choosing, at your own expense. You may request a lawyer at any time during this interview. If you decide to answer questions, you may stop the questioning at any time. Do you understand your rights? Do you want a lawyer? (If the answer is yes, cease all questions at this point). Are you willing to answer questions?

37). Describe what you understand happened leading up to and during the incident(s) of abuse.

38). Describe Soldier morale, feelings and emotional state prior to and after these incidents?

39). Was this incident reported to the chain of command? How, when & what was done? What would you have done?

40). How could the incident have been prevented?

41). Describe any unit training or other programs that you are aware of that teach leaders and Soldiers how to recognize and resolve combat stress.

42). What measures are in place to boost morale or to relieve stress

43). What measures could the command enact to improve the morale and command climate of your unit?

I. INTERROGATOR QUESTIONS

1). What references/standards/publications/SOPs do you use to conduct interrogation Operations?

2). What training have you received to ensure your knowledge of DO is IAW the provisions under the Geneva Convention?

3). Did your unit undergo Level B Law of War training prior to deployment? Explain what training occurred. Is there a plan to train new Soldiers (replacements) to the unit? Did this training include the treatment of Detainees? Explain.

4). What training did you unit receive on the established Rules of Engagement (ROE)? How often does this occur? Does this training include Rules of Interaction (ROI)?

5). What is the procedure on how to identify a detainee who may have intelligence information? Who performs this procedure? Are MPs involved in the decision-making? Are PIRs used as a basis for the identification of detainees of interest, personality lists used, etc?

6). What is the Rules of Engagement (ROE)/Rules of Interaction (ROI) when interrogating a detainee?

- 7). What is the maximum amount of time allowed a detainee could be interrogated during one session? Where is this standard located?
- 8). What is the procedure in determining how long to hold a detainee at this level for interrogation once he refuses to cooperate?
- 9). How many people are authorized to be present in the room when interrogating/screening a detainee? Under what circumstances are you required and authorized to have more people?
- 10). Who may allow an interrogator to question a detainee if he is wounded or sick? (Medical personnel)
- 11). What types of restraining devices are authorized on the detainee during the interrogation? What type and/or amount of physical constraints are interrogators authorized to place on an unruly detainee during interrogation?
- 12). Where are your screening sites located (where detainees are interrogated and screened)? Are these facilities adequate for your needs? Do you have enough interrogators for your operation needs? What are your personnel shortfalls?
- 13). Are you receiving sufficient information from the capture paperwork to properly conduct screenings and interrogations? Are the current requirements for documentation of a captured person sufficient or excessive? Did the changes in procedures as far as documenting captured person improve your ability to gather intelligence?
- 14). What are the procedures for the transfer of custody of Detainees from the MP/Guard personnel to Military Intelligence personnel? When the detainee is returned to the guard force, what procedures occur? (what info is passed on to the Guard Force (type of reward?)...observation report, paper trail audit)
- 15). Are the personal effects of a detainee released to the interrogator or is the interrogator allowed to examine the items?
- 16). How are translators/linguists used during the screening/interrogation process? Do you trust the interpreter? How are MPs/Guards used during this process?
- 17). What is your perception of the contract interrogators training and capabilities to conduct proper interrogations of detainees?
- 18). What do you perceive to be doctrinal shortcomings pertaining to Interrogation Operations? How would you fix/incorporate into updated doctrine/accomplish differently? How about Force Structure to ensure Interrogation Operations can be successfully accomplished? What are the shortcomings and how do we fix the problem at the Army-level?
- 19). Do you know of the procedures to get stress counseling (Psychiatrist, Chaplain, Medical)? Do your Soldiers know of the procedures to get counseling (Psychiatrist, Chaplain, Medical)?
- 20). What is considered abuse to a detainee during interrogation?

- 21). Are you aware of your requirement to report abuse or suspected abuse of detainees?
- 22). Do your subordinates know the reporting procedures if they observe or become aware of a Detainee being abused?
- 23). What steps would you take if a subordinate reported to you an incident of alleged Detainee abuse?
- 24). Do you feel you can freely report an incident of alleged Detainee abuse outside Command channels (IG, CID)?
- 25). What procedures do you have to report suspected detainee abuse (IG, CID, Next Level Commander)?
- 26). What procedures are in place for Detainees to report alleged abuse?
- 27). What do you perceive as the mission of your unit? Describe the importance of your role in that mission.
- 28). Describe your working environment and living conditions since being in Theater.
- 29). Describe the unit command climate and Soldier morale. Has it changed or evolved since you have been in Theater?
- 30). Are you aware of any incidences of detainee or other abuse in your unit?
- 31). **ADVISEMENT OF RIGHTS (For military personnel)**
 The text of Article 31 provides as follows a. No person subject to this chapter may compel any person to incriminate himself or to answer any questions the answer to which may tend to incriminate him. b. No person subject to this chapter may interrogate or request any statement from an accused or a person suspected of an offense without first informing him of the nature of the accusation and advising him that he does not have to make any statement regarding the offense of which he is accused or suspected, and that any statement made by him may be used as evidence against him in a trial by court-martial. c. No person subject to this chapter may compel any person to make a statement or produce evidence before any military tribunal if the statement or evidence is not material to the issue and may tend to degrade him. d. No statement obtained from any person in violation of this article, or through the use of coercion, unlawful influence, or unlawful inducement, may be received in evidence against him in a trial by court-martial.

32). I am _____(grade, if any, and name), a member of the (DAIG). I am part of a team inspecting detainee operations, this is not a criminal investigation. I am reading you your rights because of a statement you made causes me to suspect that you may have committed _____ (specify offense, i.e. aggravated assault, assault, murder). Under Article 31, you have the right to remain silent, that is, say nothing at all. Any statement you make, oral or written, may be used as evidence against you in a trial by courts-martial or in other judicial or administrative proceedings. You have the right to consult a lawyer and to have a lawyer present during this interview. You have the right to military legal counsel free of charge. In addition to military counsel, you are entitled to civilian counsel of your own choosing, at your own expense. You may request a lawyer at any time during this interview. If you decide to answer questions,

you may stop the questioning at any time. Do you understand your rights? Do you want a lawyer? (If the answer is yes, cease all questions at this point). Are you willing to answer questions?

33). Describe what you understand happened leading up to and during the incident(s) of abuse.

34). Describe Soldier morale, feelings and emotional state prior to and after these incidents?

35). Was this incident reported to the chain of command? How, when & what was done? What would you have done?

36). How could the incident have been prevented?

37). Describe any unit training or other programs that you are aware of that teach leaders and Soldiers how to recognize and resolve combat stress.

38). What measures are in place to boost morale or to relieve stress?

39). What measures could the command enact to improve the morale and command climate of your unit?

m. Chaplain

1). Are Detainees allowed to practice their religion? Is there a chaplain available to minister to the detainees? Is the chaplain a Retained Personnel, US Forces chaplain, or a civilian?

2). What are your unit ministry team's responsibilities as part of the cadre for the detainees at this collection point / internment facility? (Looking for contraband the detainee might have hidden in their Koran?)

3). What are the procedures to bring local religious clergy members into the collection point or facility to help ministry to detainees?

4). Are you aware of your requirement to report abuse or suspected abuse of detainees?

5). Has any service member spoken with you about abusing detainees or seeing detainees being abused? If yes, can you provide details without violating your privilege information / confidentially status between you and the service member? (We do not want names).

6). How many times have you heard about detainees being abused or mistreated? What did you hear?

7). Have you made the Chain of Command aware of these allegations of abuse and have you seen the Chain of Command do anything about correcting detainee abuse?

8). What is your feeling on how Detainees are being treated? No standard. Personnel observations and feelings.

9). What do you perceive as the mission of your unit? Describe the importance of your role in that mission.

10). Describe your working environment and living conditions since being in Theater.

11). Describe the unit command climate and Soldier morale. Has it changed or evolved since you have been in Theater?

12). Are you aware of any incidences of detainee or other abuse in your unit?

13). ADVISEMENT OF RIGHTS (For military personnel)

The text of Article 31 provides as follows a. No person subject to this chapter may compel any person to incriminate himself or to answer any questions the answer to which may tend to incriminate him. b. No person subject to this chapter may interrogate or request any statement from an accused or a person suspected of an offense without first informing him of the nature of the accusation and advising him that he does not have to make any statement regarding the offense of which he is accused or suspected, and that any statement made by him may be used as evidence against him in a trial by court-martial. c. No person subject to this chapter may compel any person to make a statement or produce evidence before any military tribunal if the statement or evidence is not material to the issue and may tend to degrade him. d. No statement obtained from any person in violation of this article, or through the use of coercion, unlawful influence, or unlawful inducement, may be received in evidence against him in a trial by court-martial.

14). I am _____ (grade, if any, and name), a member of the (DAIG). I am part of a team inspecting detainee operations, this is not a criminal investigation. I am reading you your rights because of a statement you made causes me to suspect that you may have committed _____. (specify offense, i.e. aggravated assault, assault, murder). Under Article 31, you have the right to remain silent, that is, say nothing at all. Any statement you make, oral or written, may be used as evidence against you in a trial by courts-martial or in other judicial or administrative proceedings. You have the right to consult a lawyer and to have a lawyer present during this interview. You have the right to military legal counsel free of charge. In addition to military counsel, you are entitled to civilian counsel of your own choosing, at your own expense. You may request a lawyer at any time during this interview. If you decide to answer questions, you may stop the questioning at any time. Do you understand your rights? Do you want a lawyer? (If the answer is yes, cease all questions at this point). Are you willing to answer questions?

15). Describe what you understand happened leading up to and during the incident(s) of abuse.

16). Describe Soldier morale, feelings and emotional state prior to and after these incidents?

17). Was this incident reported to the chain of command? How, when & what was done? What would you have done?

18). How could the incident have been prevented?

19). Describe any unit training or other programs that you are aware of that teach leaders and Soldiers how to recognize and resolve combat stress.

20). What measures are in place to boost morale or to relieve stress?

21). What measures could the command enact to improve the morale and command climate of your unit

m. S-4 (INTERMENT FACILITY)

1). Concerning logistical operations, what is your role in the support of (Theater/Division) Detainee Operations?

2). What references/standards/publications do you use to conduct Detainee Operations or does your operation depend solely on existing SOPs, OPORDs, FRAGOs, supply/logistic requests?

3). What Home Station Training did your unit conduct prior to deployment to help the unit (and you) prepare for this mission? Describe it.

4). Describe how your unit plans and procures logistical support for Detainee Operations. (include: transportation, subsistence, organizational, and NBC clothing and equipment items, distribution, laundry, and bath equipment) What are the procedures for transporting and evacuating Detainees? Have you ever coordinated for transportation to evacuate Detainees out of the AOR? Who approved the transfer?

5). Do you have any responsibilities for feeding the detainees? If so, are the daily food rations sufficient in quantity and quality and variety to keep Detainees in good health and IAW with their cultural requirements? How and what are they being fed? Please elaborate.

6). Do detainees have adequate furnishings for sleeping and eating (does it include bedding/blankets)? Is the supply system in place allowing you to replace or procure necessary furnishings? Is there a means to launder clothing items for the Detainees here at this facility

7). How do Detainees receive fresh potable water in your area of responsibility? (Bottled water, Lister bags, running water--if so, is it potable)?

8). What procedures are in place to account for and dispose of captured enemy supplies and equipment?

9). How are personal hygiene items and needed clothing being supplied to the Detainees? What precisely are provided to them? Do detainees have access to sundry items?

10). What do you perceive to be doctrinal logistic shortcomings pertaining to Detainee Operations and how would you fix/incorporate into updated doctrine/accomplish differently?

11). What are your biggest issues concerning logistical support for Detainee Operations?

12). What are your biggest issues concerning adequate facilities for Detainees? Who provides engineer support to this facility? What is your relationship with the engineer? (If the S-4 provides engineer support, then ask the Engineer Support to Internment Facility Questions.)

13). Are you aware of your requirement to report abuse or suspected abuse of detainees?

14). Do your subordinates know the reporting procedures if they observe or become aware of a Detainee being abused?

15). What steps would you take if a subordinate reported to you an incident of alleged Detainee abuse?

16). Do you feel you can freely report an incident of alleged Detainee abuse outside Command channels (IG, CID)?

17). What procedures do you have to report suspected detainee abuse (IG, CID, Next Level Commander)?

18). What procedures are in place for Detainees to report alleged abuse?

19). What do you perceive as the mission of your unit? Describe the importance of your role in that mission.

20). Describe your working environment and living conditions since being in Theater.

21). Describe the unit command climate and Soldier morale. Has it changed or evolved since you have been in Theater?

22). Are you aware of any incidences of detainee or other abuse in your unit?

23). ADVISEMENT OF RIGHTS (For military personnel)

The text of Article 31 provides as follows a. No person subject to this chapter may compel any person to incriminate himself or to answer any questions the answer to which may tend to incriminate him. b. No person subject to this chapter may interrogate or request any statement from an accused or a person suspected of an offense without first informing him of the nature of the accusation and advising him that he does not have to make any statement regarding the offense of which he is accused or suspected, and that any statement made by him may be used as evidence against him in a trial by court-martial. c. No person subject to this chapter may compel any person to make a statement or produce evidence before any military tribunal if the statement or evidence is not material to the issue and may tend to degrade him. d. No statement obtained from any person in violation of this article, or through the use of coercion, unlawful influence, or unlawful inducement, may be received in evidence against him in a trial by court-martial.

24). I am _____(grade, if any, and name), a member of the (DAIG). I am part of a team inspecting detainee operations, this is not a criminal investigation. I am reading you your rights because of a statement you made causes me to suspect that you may have committed _____. (specify offense, i.e. aggravated assault, assault, murder). Under Article 31, you have the right to remain silent, that is, say nothing at all. Any statement you make, oral or written, may be used as evidence against you in a trial by courts-martial or in other judicial or

administrative proceedings. You have the right to consult a lawyer and to have a lawyer present during this interview. You have the right to military legal counsel free of charge. In addition to military counsel, you are entitled to civilian counsel of your own choosing, at your own expense. You may request a lawyer at any time during this interview. If you decide to answer questions, you may stop the questioning at any time. Do you understand your rights? Do you want a lawyer? (If the answer is yes, cease all questions at this point). Are you willing to answer questions?

25). Describe what you understand happened leading up to and during the incident(s) of abuse.

26). Describe Soldier morale, feelings and emotional state prior to and after these incidents?

27). Was this incident reported to the chain of command? How, when & what was done? What would you have done?

28). How could the incident have been prevented?

29). Describe any unit training or other programs that you are aware of that teach leaders and Soldiers how to recognize and resolve combat stress.

30). What measures are in place to boost morale or to relieve stress?

31). What measures could the command enact to improve the morale and command climate of your unit?

n. CID Special Agent

1). What is your involvement with detainee abuse investigations? Please provide a general description of the quantity and type of investigations that you were involved in?

2). Can you list the detainee facilities that these incidents occurred?

3). During those investigations did you establish the motives for soldiers that abused detainees? If so, please list the motives you uncovered and explain each individually in as much detail as possible.

4). During those investigations, did you establish any deficiencies regarding training of those persons who committed abuse? If so, please explain?

5). During those investigations, did you establish any deficiencies in regards to the leadership of those who committed abuse? If so, please explain?

6). During those investigations, did you establish if the environmental factors (length of work day, shift schedule, living conditions, weather, food, etc...) might have been the cause of abuse? If so, explain?

7). During those investigations, did you determine if combat stress was a cause of the abuse? If so, please explain.

8). During those investigations did you establish if the assignment of MOS' that do not normally deal with detainee operations had an impact on those soldiers abusing detainees. If so, please explain.

9). During these investigations did you establish any patterns as far as one unit having more soldiers who abused detainees, or a specific MOS that had more soldiers who abused detainees. Did you see any specific patterns?

10): Is there anything else that you may have observed that you felt was the cause of those soldiers abusing detainees?

11). What do you perceive as the mission of your unit? Describe the importance of your role in that mission.

12). Describe your working environment and living conditions since being in Theater.

13). Describe the unit command climate and Soldier morale. Has it changed or evolved since you have been in Theater?

14). Are you aware of any incidences of detainee or other abuse in your unit?

15). ADVISEMENT OF RIGHTS (For military personnel)

The text of Article 31 provides as follows a. No person subject to this chapter may compel any person to incriminate himself or to answer any questions the answer to which may tend to incriminate him. b. No person subject to this chapter may interrogate or request any statement from an accused or a person suspected of an offense without first informing him of the nature of the accusation and advising him that he does not have to make any statement regarding the offense of which he is accused or suspected, and that any statement made by him may be used as evidence against him in a trial by court-martial. c. No person subject to this chapter may compel any person to make a statement or produce evidence before any military tribunal if the statement or evidence is not material to the issue and may tend to degrade him. d. No statement obtained from any person in violation of this article, or through the use of coercion, unlawful influence, or unlawful inducement, may be received in evidence against him in a trial by court-martial.

16). I am _____(grade, if any, and name), a member of the (DAIG). I am part of a team inspecting detainee operations, this is not a criminal investigation. I am reading you your rights because of a statement you made causes me to suspect that you may have committed _____. (specify offense, i.e. aggravated assault, assault, murder). Under Article 31, you have the right to remain silent, that is, say nothing at all. Any statement you make, oral or written, may be used as evidence against you in a trial by courts-martial or in other judicial or administrative proceedings. You have the right to consult a lawyer and to have a lawyer present during this interview. You have the right to military legal counsel free of charge. In addition to military counsel, you are entitled to civilian counsel of your own choosing, at your own expense. You may request a lawyer at any time during this interview. If you decide to answer questions, you may stop the questioning at any time. Do you understand your rights? Do you want a lawyer? (If the answer is yes, cease all questions at this point). Are you willing to answer questions?

17). Describe what you understand happened leading up to and during the incident(s) of abuse.

18). Describe Soldier morale, feelings and emotional state prior to and after these incidents?

19). Was this incident reported to the chain of command? How, when & what was done? What would you have done?

20). How could the incident have been prevented?

21). Describe any unit training or other programs that you are aware of that teach leaders and Soldiers how to recognize and resolve combat stress.

22). What measures are in place to boost morale or to relieve stress

23). What measures could the command enact to improve the morale and command climate of your unit?

n. ENGINEER SUPPORT TO INTERNMENT FACILITIES (MP BDE/BN)

1). What is your role in assisting this unit to maintain the security and safeguarding of Detainees at this internment facility?

2). What is the maximum capacity for this particular facility? What is the current Detainee population? What is your plan for surge? (tentage, latrines, etc)

3). What standards were used in establishing this internment facility? What standards do you use in providing engineer support for this facility? Have any facility standards been waived, and if so, by whom, and why?

4). Why was this facility picked as an internment facility (permanent)? What makes this the place of choice? Who decided the location of this facility?

5). What are some of the services being contracted out/outsourced to support Detainee Operations in Theater? (Custodial, Garbage, etc.) What are issues concerning contracting or budget that you are aware of that impact Detainee Operations? If so, what are they? Who oversees these contracts that support Detainee Operations (CORs)?

6). What do you know about the Engineer Corps' Theater Construction Management System (TCMS). Were you aware that they have plans, specifications, and materiel requirements for Internment Facilities based on Detainee population?

7). What is the minimum living space standard for each Detainee? Who set the provisions of minimum living space for this facility (Engineers are managers of real property) (when possible, consult the preventative medicine authority in theater for provisions of minimum living space and sanitary facilities). What is your relationship with the preventive medicine expert? Has a preventative medicine expert given advice on this?

8). Describe the latrine facilities for Detainees' use (do they have access to it day and night and does it conform to the rules of hygiene and do females have separate facilities. Are they serviced with running water)? How are they cleaned and how often, and by whom

(Contracted?)? Where do they bathe and conduct other personal hygiene? How recently has a preventative medicine expert inspected the latrine and personal hygiene facilities?

9). Is the sewage system intact? If not, what are the problems and what is being done to fix. What is used in lieu of?

10). Describe your lighting system for the internment facility. How does it enhance the security of the facility? Does the facility have emergency lighting/power capability? Describe the system. How about the electrical distribution system? What are your problems with the system?

11). How do the Detainees receive fresh potable water (Bottled water, Lister bags, running water--if so, is it potable)? How reliable is the (running) water distribution system (any breakdowns and if so, how often)?

12). How about heating during the winter? What fire prevention/safety measures are in place? Describe major problems in these areas.

13). Describe the facilities where the Detainees eat? (Is there a kitchen facility), what equipment do you have in place?

14). Do you train and supervise internal and external labor (CIs) (construction and repair of facilities)? If so, describe the work ((construction, maintenance, repair, and operation of utilities (water, electricity, heat, and sanitation.))

15). How do you prioritize your maintenance and repair? What is your backlog on work orders? Are there any future plans for this facility in terms of renovation or expansion? Please describe (how will they use swing space).

16). Are you aware of your requirement to report abuse or suspected abuse of detainees?

17). Do your subordinates know the reporting procedures if they observe or become aware of a Detainee being abused?

18). What steps would you take if a subordinate reported to you an incident of alleged Detainee abuse?

19). Do you feel you can freely report an incident of alleged Detainee abuse outside Command channels (IG, CID)

20). What procedures do you have to report suspected detainee abuse (IG, CID, Next Level Commander)

21). What procedures are in place for Detainees to report alleged abuse?

22). What do you perceive as the mission of your unit? Describe the importance of your role in that mission

23). Describe your working environment and living conditions since being in Theater.

24). Describe the unit command climate and Soldier morale. Has it changed or evolved since you have been in Theater?

25). Are you aware of any incidences of detainee or other abuse in your unit?

26). ADVISEMENT OF RIGHTS (For military personnel)

The text of Article 31 provides as follows a. No person subject to this chapter may compel any person to incriminate himself or to answer any questions the answer to which may tend to incriminate him. b. No person subject to this chapter may interrogate or request any statement from an accused or a person suspected of an offense without first informing him of the nature of the accusation and advising him that he does not have to make any statement regarding the offense of which he is accused or suspected, and that any statement made by him may be used as evidence against him in a trial by court-martial. c. No person subject to this chapter may compel any person to make a statement or produce evidence before any military tribunal if the statement or evidence is not material to the issue and may tend to degrade him. d. No statement obtained from any person in violation of this article, or through the use of coercion, unlawful influence, or unlawful inducement, may be received in evidence against him in a trial by court-martial.

27). I am _____(grade, if any, and name), a member of the (DAIG). I am part of a team inspecting detainee operations, this is not a criminal investigation. I am reading you your rights because of a statement you made causes me to suspect that you may have committed _____(specify offense, i.e. aggravated assault, assault, murder). Under Article 31, you have the right to remain silent, that is, say nothing at all. Any statement you make, oral or written, may be used as evidence against you in a trial by courts-martial or in other judicial or administrative proceedings. You have the right to consult a lawyer and to have a lawyer present during this interview. You have the right to military legal counsel free of charge. In addition to military counsel, you are entitled to civilian counsel of your own choosing, at your own expense. You may request a lawyer at any time during this interview. If you decide to answer questions, you may stop the questioning at any time. Do you understand your rights? Do you want a lawyer? (If the answer is yes, cease all questions at this point). Are you willing to answer questions?

28). Describe what you understand happened leading up to and during the incident(s) of abuse.

29). Describe Soldier morale, feelings and emotional state prior to and after these incidents?

30). Was this incident reported to the chain of command? How, when & what was done? What would you have done?

31). How could the incident have been prevented?

32). Describe any unit training or other programs that you are aware of that teach leaders and Soldiers how to recognize and resolve combat stress.

33). What measures are in place to boost morale or to relieve stress?

34). What measures could the command enact to improve the morale and command climate of your unit?

o. Medical Officer / Preventive Medical Officer

- 1). What medical requirements in support of the detainee program were identified in the medical annexes of relevant OPLANs, OPORDs, and other contingency planning documents? What identified requirements were actually allocated? What procedures were specified in these documents
- 2). What training, specific to detainee medical operations, did you receive prior to this deployment? What training have you received during this deployment?
- 3). What are the minimum medical care and field sanitation standards for collection points/internment facilities? What have you observed when detainees are received at collection points/internment facilities? (Describe the process)
- 4). How often are the collection points/internment facilities inspected (PVNTMED inspections)? Who performs the inspections (field sanitation team, PVNTMED detachment)? What do the inspections consist of? What do you do with the results of the inspections? Are the appropriate commanders taking the necessary actions to correct the shortcomings noted during your monthly medical inspections? Have you observed any recurring deficiencies during your inspections?
- 5). How do you ensure that each unit has a field sanitation team and all necessary field sanitation supplies? What PVNTMED personnel are assigned to MP units responsible for detention operations?
- 6). How are detainees initially evaluated (screened) and treated for medical conditions (same as US)? Who performs the screening? What do you do if a detainee is suspected of having a communicable disease (isolated)?
- 7). How often do you or your staff conduct routine medical inspections (examinations) of detainees? What does the medical evaluation consist of? What is the purpose of the medical examination? How are the results recorded/reported?
- 8). Does every internment facility have an infirmary? If not, why not? How do detainees request medical care? What are the major reasons detainees require medical care? Have any detainees been denied medical treatment or has medical attention been delayed? If so, why?
- 9). How do detainees obtain personal hygiene products?
- 10). What are the procedures for the transfer of custody of detainees to/from the infirmary for medical treatment? How is security maintained when a detainee is transferred to a medical facility? (Database, form, etc
- 11). What are the procedures for repatriation of sick and wounded detainees? Who is eligible for repatriation based on a medical condition? How do you interact with the Mixed Medical Commission (EPW/RP only)?
- 12). Who maintains medical records of detainees? How are these maintained and accessed? What is kept in the medical record? Who collects, analyzes, reports, and responds to detainee DNBI data

13). What are the standards for detainee working conditions? Who monitors and enforces them? Who administers the safety program? What is included in the safety program? How does a detainee apply for work-related disability compensation

14). How are retained medical personnel identified? What special conditions apply to them? How are they employed in the care of detainees? How are they certified as proficient? Who supervises them?

15). What measures are taken to protect US personnel from contracting diseases carried by detainees? Who monitors/enforces these procedures?

16). What kind of stress counseling do you provide to Soldiers/Guards of detainees?

17). What are the procedures if a detainee in U.S. custody dies?

18). What do you perceive to be doctrinal medical shortcomings pertaining to detainee operations? How would you fix/incorporate into updated doctrine/accomplish differently? Does the current force structure of the Medical/MS/SP Corps support the successful accomplishment of detainee operations? What are the shortcomings, and how do we fix the problem at the Army level?

19). If you noticed any markings and/or injuries on a detainee that might lead you to believe the detainee was being abused, what would you do with the information? Do your subordinates know the reporting procedures if they observe or become aware of a detainee being abused?

20). Overall, how do you feel detainees are being treated at the infirmary, collection points and/or detention facilities? What systemic weaknesses have you identified?

21). What AARs or lessons learned have you written or received regarding detainee operations? Can I get a copy?

22). What do you perceive as the mission of your unit? Describe the importance of your role in that mission.

23). Describe your working environment and living conditions since being in Theater.

24). Describe the unit command climate and Soldier morale. Has it changed or evolved since you have been in Theater?

25). Are you aware of any incidences of detainee or other abuse in your unit?

26). ADVISEMENT OF RIGHTS (For military personnel)

The text of Article 31 provides as follows a. No person subject to this chapter may compel any person to incriminate himself or to answer any questions the answer to which may tend to incriminate him. b. No person subject to this chapter may interrogate or request any statement from an accused or a person suspected of an offense without first informing him of the nature of the accusation and advising him that he does not have to make any statement regarding the offense of which he is accused or suspected, and that any statement made by him may be used as evidence against him in a trial by court-martial. c. No person subject to this chapter may

compel any person to make a statement or produce evidence before any military tribunal if the statement or evidence is not material to the issue and may tend to degrade him. d. No statement obtained from any person in violation of this article, or through the use of coercion, unlawful influence, or unlawful inducement, may be received in evidence against him in a trial by court-martial.

27). I am _____(grade, if any, and name), a member of the (DAIG). I am part of a team inspecting detainee operations, this is not a criminal investigation. I am reading you your rights because of a statement you made causes me to suspect that you may have committed _____ (specify offense, i.e. aggravated assault, assault, murder). Under Article 31, you have the right to remain silent, that is, say nothing at all. Any statement you make, oral or written, may be used as evidence against you in a trial by courts-martial or in other judicial or administrative proceedings. You have the right to consult a lawyer and to have a lawyer present during this interview. You have the right to military legal counsel free of charge. In addition to military counsel, you are entitled to civilian counsel of your own choosing, at your own expense. You may request a lawyer at any time during this interview. If you decide to answer questions, you may stop the questioning at any time. Do you understand your rights? Do you want a lawyer? (If the answer is yes, cease all questions at this point). Are you willing to answer questions?

28). Describe what you understand happened leading up to and during the incident(s) of abuse.

29). Describe Soldier morale, feelings and emotional state prior to and after these incidents?

30). Was this incident reported to the chain of command? How, when & what was done? What would you have done?

31). How could the incident have been prevented?

32). Describe any unit training or other programs that you are aware of that teach leaders and Soldiers how to recognize and resolve combat stress.

33). What measures are in place to boost morale or to relieve stress?

34). What measures could the command enact to improve the morale and command climate of your unit?

p. NCOIC GUARD FORCE COLLECTION POINT & INTERNMENT FACILITY

1). How did you prepare yourself and your Soldiers to become familiar with and understand the applicable regulations, OPORDS/FRAGOs directives, international laws and administrative procedures to operate an I/R facility or Collection Point?

2). Did you and all of your Soldiers undergo Law of War training prior to deployment? Explain what training occurred. What is your plan to train new Soldiers (replacements) to the unit? Did this training include the treatment of Detainees? Explain.

3). What policies/procedures does your unit have in place to support the U. S. policy relative to the humane treatment of Detainees?

- 4). Does your unit have a formal training program for the care and control of Detainees? Describe what it includes. (For Permanent Internment Facilities only)
- 5). What training did your unit receive on the established Rules of Engagement (ROE)? How often does this occur? Does this training include Rules of Interaction (ROI)?
- 6). What procedures do you have in place to ensure Soldiers understand the use of force and rules of engagement for the internment facility/collection point?
- 7). What guidance or policies do you have to ensure fraternization is not taking place between U.S. military personnel and the detainees?
- 8). Describe the training the guard force received to prepare them for their duties (5Ss & T)) How does your unit conduct sustainment training for Detainee Operations in Theater? How often does this occur and please describe it? When did your unit last conduct this training?
- 9). What Home Station/Mob Site Training did your unit conduct prior to deployment to help your unit prepare for Detainee Operations? Describe it. How did the training prepare you to conduct Detainee Operations for this deployment? What are your unit's strengths and weaknesses? How did this training distinguish between the different categories of Detainees (EPWs, RPs, CIs, etc.)?
- 10). Describe the training you received during your last Military Institutional School (BNCOC/ANCOC) in handling/processing Detainees. How was it helpful in preparing you for Detainee Operations? How would you improve the training at the schoolhouse?
- 11). What are some of the basic operations of the collection point/internment facility? Is there a copy of the Geneva Convention posted in the detainee's home language within these camps? Are camps segregating Detainees by nationality, language, rank, and sex? How are captured Medical personnel and Chaplains being used in the camps? What provisions are in place for the receipt and distribution of Detainee correspondence/mail? Are the daily food rations sufficient in quantity or quality and variety to keep detainees in good health? Are personal hygiene items and needed clothing being supplied to the Detainees? Are the conditions within the camp sanitary enough to ensure a clean and healthy environment free from disease and epidemics? Is there an infirmary located within the camp?
- 12). What control measures are your unit using to maintain discipline and security in the collection point/internment facility?
- 13). What procedures are in place to account for and dispose of captured enemy supplies and equipment? What procedures are in place to process personnel, equipment, and evidence?
- 14). What is your ratio of guards to detainees in your collection point/internment facility? Is this ratio the proper mix for you to perform your mission? If not, what are the shortfalls? Why are their shortfalls? How do these shortfalls impact your mission?
- 15). How are you organized to handle the different categories of personnel (EPW, CI, OD, females, juveniles and refugees)? Do you maintain a separate site for sick or wounded

Detainees? If so where is it and how does your unit maintain the security and safeguarding of Detainees there?

16). What is the number of personnel needed to escort prisoners internally and externally? (i.e. for medical, evacuation, etc.)?

17). What are the procedures for transporting and evacuating detainees? What are the procedures for transferring Detainees from the collection points to US Military controlled detention facilities? How is the transfer of Detainees handled between different services?

18). What are the procedures for the transfer of custody of Detainees from the collection points/internment facility to Military Intelligence/OGA personnel? When the detainee is returned to the guard force, what procedures occur with the detainee? (in processing, medical screening, suicide watch, observation report DD Form 2713?, etc)

19). What MP units (guards, escort, detachments) do you have at your disposal to operate and maintain this collection point/internment facility? What non-MP units are you using to help operate this collection point/internment facility? If you do not use MP teams, what forces are required to operate the Collection Point (guard, security etc)? Do you have any shortfalls in performing the Collection Point mission? How does this affect your doctrinal mission? How long are you holding Detainees at the collection point? Is holding the detainees longer than the 12/24 hours impacting on your units' ability to perform its mission? Why?

20). Describe how this unit is able to maintain the security and safeguarding of Detainees at this internment facility/collection point. Describe your security requirements. (What are your clear zones? How do your Guard Towers permit an unobstructed view of the clear zone and how do they allow for overlapping fields of fire? Describe your perimeter security.

21). How do you maintain a high state of discipline with your Soldiers to enhance the internal and external security of the internment facility/Collection Point?

22). Does this facility include Sally Ports? Describe the system in place.

23). What do you have in place for communications (between guards/towers and the TOC/C²)? What problems do you have? How do you overcome them?

24). Describe the latrine facilities for Detainees' use (do they have access to it day and night and does it conform to the rules of hygiene and do females have separate facilities). How are they cleaned and how often and by whom? Where do they bathe and conduct other personal hygiene (this will depend how long it takes to evacuate Detainees to U.S. Military Controlled Detention Facilities—12/24 hours is the standard)?

25). How do the Detainees receive fresh water (Bottled water or Lister bag)?

26). Can you give some examples of contraband? What are the procedures when you find contraband?? (i.e., Knives, Narcotics, weapons, currency)

27). Describe your lighting systems at the Facility/Collection Point (how does it affect security) . How about heating during the winter? What fire prevention/safety measures are in place?

- 28). How are Detainee complaints and requests to the camp commander processed?
- 29). What are your shortcomings/problems in feeding the population? What is the menu of the population?
- 30). What problems, if any, do you feel the unit has regarding manning or personnel resourcing in conducting Detention Operations? What about the number of personnel to control the detention operation in regards to riot control?
- 31). What personal equipment is the unit experiencing as a shortfall concerning detainee operations, (i.e., restraints, uniforms, CIF items, weapons, etc)?
- 32). What types of supplies is greater in-demand for the unit during detainee operations? And are these items regularly filled? What major shortfalls has the unit encountered in regard to materiel and supply distribution?
- 33). What transportation problems is the unit experiencing to move detainees during the operation?
- 34). What safety programs/policies are currently being used in the Detainee camps?
- 35). Do you know of the procedures to get stress counseling (Psychiatrist, Chaplain, Medical)? Do your Soldiers know of the procedures to get counseling (Psychiatrist, Chaplain, Medical)?
- 36). Are you aware of your requirement to report abuse or suspected abuse of detainees?
- 37). Do your subordinates know the reporting procedures if they observe or become aware of a Detainee being abused?
- 38). What steps would you take if a subordinate reported to you an incident of alleged Detainee abuse?
- 39). Do you feel you can freely report an incident of alleged Detainee abuse outside Command channels (IG, CID)?
- 40). What procedures do you have to report suspected detainee abuse (IG, CID, Next Level Commander)?
- 41). What systems are in place for detainees to report alleged abuse?
- 42). What do you perceive as the mission of your unit? Describe the importance of your role in that mission.
- 43). Describe your working environment and living conditions since being in Theater.
- 44). Describe the unit command climate and Soldier morale. Has it changed or evolved since you have been in Theater?
- 45). Are you aware of any incidences of detainee or other abuse in your unit?

46). ADVISEMENT OF RIGHTS (For military personnel)

The text of Article 31 provides as follows a. No person subject to this chapter may compel any person to incriminate himself or to answer any questions the answer to which may tend to incriminate him. b. No person subject to this chapter may interrogate or request any statement from an accused or a person suspected of an offense without first informing him of the nature of the accusation and advising him that he does not have to make any statement regarding the offense of which he is accused or suspected, and that any statement made by him may be used as evidence against him in a trial by court-martial. c. No person subject to this chapter may compel any person to make a statement or produce evidence before any military tribunal if the statement or evidence is not material to the issue and may tend to degrade him. d. No statement obtained from any person in violation of this article, or through the use of coercion, unlawful influence, or unlawful inducement, may be received in evidence against him in a trial by court-martial.

47). I am _____(grade, if any, and name), a member of the (DAIG). I am part of a team inspecting detainee operations, this is not a criminal investigation. I am reading you your rights because of a statement you made causes me to suspect that you may have committed _____ (specify offense, i.e. aggravated assault, assault, murder). Under Article 31, you have the right to remain silent, that is, say nothing at all. Any statement you make, oral or written, may be used as evidence against you in a trial by courts-martial or in other judicial or administrative proceedings. You have the right to consult a lawyer and to have a lawyer present during this interview. You have the right to military legal counsel free of charge. In addition to military counsel, you are entitled to civilian counsel of your own choosing, at your own expense. You may request a lawyer at any time during this interview. If you decide to answer questions, you may stop the questioning at any time. Do you understand your rights? Do you want a lawyer? (If the answer is yes, cease all questions at this point). Are you willing to answer questions?

48). Describe what you understand happened leading up to and during the incident(s) of abuse.

49). Describe Soldier morale, feelings and emotional state prior to and after these incidents?

50). Was this incident reported to the chain of command? How, when & what was done? What would you have done?

51). How could the incident have been prevented?

52). Describe any unit training or other programs that you are aware of that teach leaders and Soldiers how to recognize and resolve combat stress.

53). What measures are in place to boost morale or to relieve stress

54). What measures could the command enact to improve the morale and command climate of your unit?

q. POINT OF CAPTURE-- CDR/ 1SG/ PL/ PS

- 1). How did you prepare yourself and your junior leaders to become familiar with and understand the applicable regulations, OPORDS/FRAGOs directives, international laws and administrative procedures to operate a unit Collection Point?
- 2). Did you and all of your Soldiers undergo Law of War training prior to deployment? Explain what training occurred. Did this training include the treatment of Detainees? Is there a plan to train new Soldiers (replacements) to the unit? Explain.
- 3). What Home Station/Mob Site Training did your unit conduct prior to deployment to help your unit prepare for Detainee Operations? Describe it. How did the training prepare you to conduct Detainee Operations for this deployment? How did this training distinguish between the different categories of Detainees (EPWs, RPs, CIs, etc.)?
- 4). What training did you receive on the established Rules of Engagement (ROE)? How often does this occur? Does this training include Rules of Interaction (ROI)?
- 5). Describe the training you received at the last Professional Military Education on handling/processing Detainees. How was it helpful in preparing you for Detainee Operations? How would you improve the training at the schoolhouse?
- 6). Describe the training the guard force received to prepare them for their duties. How do you ensure your guards understand their orders?
- 7). How does your unit conduct sustainment training for Detainee Operations? How often does this occur and please describe it? When did your unit last conduct this training?
- 8). (CDR/1SG) What are your policies on the establishment of a unit holding area? How do you ensure that these areas operate IAW Law of War?
- 9). (PL/PS) What is the units' policy on the establishment of a unit holding area? How do you know that you are operating the holding areas IAW Law of War? ?
- 10). How do you administratively process each detainee, (i.e., tagging pax and equipment, evidence, witness statements, etc.)?
- 11). How do you maintain good morale and discipline with Soldiers and leaders to enhance the security of the unit collection point?
- 12). What procedures do you have in place to ensure Soldiers and leaders understand the use of force and rules of engagement for the unit collection point? (ROE Card, sustainment tng, etc)
- 13). What procedures are in place to dispose of captured contraband (enemy supplies and equipment)?
- 14). (CDR/1SG) What policies/procedures do you have in place to ensure that all Detainees are protected, safeguarded, and accounted for (5Ss & T)? What policies/procedures does your unit have to ensure the humane treatment of Detainees?
- 15). What are your procedures for questioning Detainees? (Is interrogation taking place?) Who is interrogating the detainees?

- 16). What are your procedures to evacuate a detainee from the point of capture to the Battalion/Brigade collection point? What transportation problems is the unit experiencing either to move troops or detainees during the operation? How do you process detainees too sick or wounded to be evacuated?
- 17). What is the number of personnel that is needed to move prisoners within the holding area and then to higher? (i.e. for medical sick call, evacuation, etc.)?
- 18). What medical personnel are available to support DO?
- 19). What procedures are in place when a detainee in U S custody dies?
- 20). What equipment is the unit experiencing as a shortfall concerning detainee operations, (i.e., restraints, uniforms, CIF items, radios, weapons, etc.)?
- 21). (CDR) Are any of these USR shortages and if so are you reporting them on your USR?
- 22). What types of supplies is greater in-demand for the unit during detainee operations? What about health and comfort items? And are these items regularly filled?
- 23). What duties put the most stress on soldiers in terms of personnel resources?
- 24). What is the most important factor that you would address in terms of personnel resources in regards to a successful detainee operation?
- 25). What AARs or lessons learned have you written or received regarding detainee operations? Can I get a copy?
- 26). Do you know of the procedures to get stress counseling (Psychiatrist, Chaplain, Medical)? Do your Soldiers know of the procedures to get counseling (Psychiatrist, Chaplain, Medical)?
- 27). Are you aware of your requirement to report abuse or suspected abuse of detainees?
- 28). Do your subordinates know the reporting procedures if they observe or become aware of a Detainee being abused?
- 29). What steps would you take if a subordinate reported to you an incident of alleged Detainee abuse?
- 30). Do you feel you can freely report an incident of alleged Detainee abuse outside Command channels (IG, CID)?
- 31). What procedures do you have to report suspected detainee abuse (IG, CID, Next Level Commander)?
- 32). What systems are in place for detainees to report alleged abuse?
- 33). What do you perceive as the mission of your unit? Describe the importance of your role in that mission.

- 34). Describe your working environment and living conditions since being in Theater.
- 35). Describe the unit command climate and Soldier morale. Has it changed or evolved since you have been in Theater?
- 36). Are you aware of any incidences of detainee or other abuse in your unit?
- 37). **ADVISEMENT OF RIGHTS (For military personnel)**
 The text of Article 31 provides as follows a. No person subject to this chapter may compel any person to incriminate himself or to answer any questions the answer to which may tend to incriminate him. b. No person subject to this chapter may interrogate or request any statement from an accused or a person suspected of an offense without first informing him of the nature of the accusation and advising him that he does not have to make any statement regarding the offense of which he is accused or suspected, and that any statement made by him may be used as evidence against him in a trial by court-martial. c. No person subject to this chapter may compel any person to make a statement or produce evidence before any military tribunal if the statement or evidence is not material to the issue and may tend to degrade him. d. No statement obtained from any person in violation of this article, or through the use of coercion, unlawful influence, or unlawful inducement, may be received in evidence against him in a trial by court-martial.
- 38). I am _____(grade, if any, and name), a member of the (DAIG). I am part of a team inspecting detainee operations, this is not a criminal investigation. I am reading you your rights because of a statement you made causes me to suspect that you may have committed _____ (specify offense, i.e. aggravated assault, assault, murder). Under Article 31, you have the right to remain silent, that is, say nothing at all. Any statement you make, oral or written, may be used as evidence against you in a trial by courts-martial or in other judicial or administrative proceedings. You have the right to consult a lawyer and to have a lawyer present during this interview. You have the right to military legal counsel free of charge. In addition to military counsel, you are entitled to civilian counsel of your own choosing, at your own expense. You may request a lawyer at any time during this interview. If you decide to answer questions, you may stop the questioning at any time. Do you understand your rights? Do you want a lawyer? (If the answer is yes, cease all questions at this point). Are you willing to answer questions?
- 39). Describe what you understand happened leading up to and during the incident(s) of abuse.
- 40). Describe Soldier morale, feelings and emotional state prior to and after these incidents?
- 41). Was this incident reported to the chain of command? How, when & what was done? What would you have done?
- 42). How could the incident have been prevented?
- 43). Describe any unit training or other programs that you are aware of that teach leaders and Soldiers how to recognize and resolve combat stress.
- 44). What measures are in place to boost morale or to relieve stress?

45). What measures could the command enact to improve the morale and command climate of your unit?

r. DETAINEE ADMINISTRATION COLLECTION POINT/INTERMENT FACILITY

1). Can you tell me what basic publications that you use to get doctrine and standards for Detainee Operations? How are you applying standards/doctrine to your processing of Detainees?

2). How often does your immediate supervisor/commander come here to ensure that Detainee Operations is conducted in compliance with the international Law of war? How about other commanders in your chain of command?

3). Describe the in processing for Detainees at this Collection Point/Internment Facility. (TAGGING, EQUIPMENT, EVIDENCE, SWORN STATEMENTS, ETC)? By what means are they transported here? How long do Detainees typically stay here (12/24 hours is the standard for each location of captivity until they get to the Long Term Detention Facility)? How long does it typically take Detainees to get here after capture? How are they out-processed and where do they go? How are they transported to the next higher level facility/Collection Point? (What is the documentation required for the transfer of prisoners/Civilian Internees? (What is the documentation required for the transfer of Detainees to other locations or to either MI Soldiers or other U.S. Government Agencies?)

4). What are the procedures for the transfer of custody of Detainees from the MP/Guard personnel to Military Intelligence personnel? When the detainee is returned to the guard force, what procedures occur? (what info is passed on to the Guard Force (type of reward?)...observation report, paper trail audit)

5). What is your Detainee segregation policy? (EPWs, Females, Juveniles, Civilian Internees (to include those that are security threats, those that are hostile to coalition forces, and possible HTD/HVD), and Retained Persons, Criminals, etc.)) What can you tell me about the categories of Detainees that you are holding? What are they and what are the definitions of the different categories that you detain? How are you organized to handle the different categories of Detainees (EPW, CI, HVD, OD, and refugees?)

6). What happens to weapons/contraband confiscated from Detainees? What happens to personal property? (Is it disposed of/tagged along with the Detainee and is it stored properly and accounted for?) Why is the DD Form 2745 (Capture Tag) not being used in country? Who gave the authority not to use this form? What are units using in lieu of (if any)? ((Detainee Capture Card found in draft MTTP, Detainee Ops—this card does not require near as much data as DD 2745. The CPA Apprehension Form helps offset the lack of info on the Detainee, however it is in single copy (not the 3 required))) Who decided on the use of the Coalition Provisional Authority Apprehension Form? Why and under whose authority?

7). How are interpreters (linguists/translators) used in this Collection Point/Internment Facility? How many do you have at your disposal? How do you obtain them? Do you and your Soldiers trust them?

8). (COLLECTING POINT ONLY) Are the daily food rations sufficient in quantity or quality and variety to keep detainees in good health (HOW MUCH FOOD DO THEY GET)? Are

personal hygiene items and needed clothing being supplied to the Detainees if they are kept longer than 12/24 hours here? Explain?

- 9). Are you aware of your requirement to report abuse or suspected abuse of detainees?
- 10). Do your subordinates know the reporting procedures if they observe or become aware of a Detainee being abused?
- 11). What steps would you take if a subordinate reported to you an incident of alleged Detainee abuse? Do you feel you can freely report an incident of alleged Detainee abuse outside Command channels (IG, CID)
- 12). What procedures do you have to report suspected detainee abuse (IG, CID, Next Level Commander)
- 13). What procedures are in place for Detainees to report alleged abuse?
- 14). What do you perceive as the mission of your unit? Describe the importance of your role in that mission.
- 15). Describe your working environment and living conditions since being in Theater.
- 16). Describe the unit command climate and Soldier morale. Has it changed or evolved since you have been in Theater
- 17). Are you aware of any incidences of detainee or other abuse in your unit?
- 18). ADVISEMENT OF RIGHTS (For military personnel)
The text of Article 31 provides as follows a. No person subject to this chapter may compel any person to incriminate himself or to answer any questions the answer to which may tend to incriminate him. b. No person subject to this chapter may interrogate or request any statement from an accused or a person suspected of an offense without first informing him of the nature of the accusation and advising him that he does not have to make any statement regarding the offense of which he is accused or suspected, and that any statement made by him may be used as evidence against him in a trial by court-martial. c. No person subject to this chapter may compel any person to make a statement or produce evidence before any military tribunal if the statement or evidence is not material to the issue and may tend to degrade him. d. No statement obtained from any person in violation of this article, or through the use of coercion, unlawful influence, or unlawful inducement, may be received in evidence against him in a trial by court-martial.
- 19). I am _____(grade, if any, and name), a member of the (DAIG). I am part of a team inspecting detainee operations, this is not a criminal investigation. I am reading you your rights because of a statement you made causes me to suspect that you may have committed _____. (specify offense, i.e. aggravated assault, assault, murder). Under Article 31, you have the right to remain silent, that is, say nothing at all. Any statement you make, oral or written, may be used as evidence against you in a trial by courts-martial or in other judicial or administrative proceedings. You have the right to consult a lawyer and to have a lawyer present during this interview. You have the right to military legal counsel free of charge. In addition to military counsel, you are entitled to civilian counsel of your own choosing, at your own expense.

You may request a lawyer at any time during this interview. If you decide to answer questions, you may stop the questioning at any time. Do you understand your rights? Do you want a lawyer? (If the answer is yes, cease all questions at this point). Are you willing to answer questions?

- 20). Describe what you understand happened leading up to and during the incident(s) of abuse.
- 21). Describe Soldier morale, feelings and emotional state prior to and after these incidents?
- 22). Was this incident reported to the chain of command? How, when & what was done? What would you have done?
- 23). How could the incident have been prevented?
- 24). Describe any unit training or other programs that you are aware of that teach leaders and Soldiers how to recognize and resolve combat stress.
- 25). What measures are in place to boost morale or to relieve stress
- 26). What measures could the command enact to improve the morale and command climate of your unit

2. SENSING SESSION QUESTIONS

a. NCO (Point of Capture)

- 1). What regulations, directives, policies, are you aware of that deal with detainee operations?
- 2). Did you and all of your Soldiers undergo Law of War/Geneva Convention training prior to deployment? Explain what training occurred. Did this training include the treatment of Detainees? What is your plan to train new Soldiers (replacements) to the unit? Explain.
- 3). What training did your unit receive on the established Rules of Engagement (ROE)? How often does this occur? Does this training include Rules of Interaction (ROI) (How can you interact with the detainees)?
- 4). Does your unit conduct sustainment training for Detainee Operations? How often does this occur and please describe it? When did your unit last conduct this training?
- 5). What Home Station/Mob Site Training did your unit conduct prior to deployment to help your unit prepare for Detainee Operations? Describe it. How did the training prepare you to conduct Detainee Operations for this deployment? What are your unit's strengths and weaknesses? How did this training distinguish between the different categories of Detainees (EPWs, RPs, CIs, etc.)?
- 6). Describe the training you received During PLDC/BNCOC/ANCOC in handling/processing Detainees. How was it helpful in preparing you for Detainee Operations? How would you improve the training at the schoolhouse?

- 7). What procedures are in place to ensure Soldiers understand the use of force and rules of engagement? (ROE Card? Etc)
- 8). How do you maintain discipline and security until the detainees are handed off to higher? Describe the training/GUIDANCE the guard force received to prepare them for their duties?
- 9). What is the minimum standard of treatment US Soldiers must provide detainees? What policies/procedures does your unit have to ensure the humane treatment of Detainees? What procedures does your unit have in place to ensure that Detainees are protected, safeguarded, and accounted for?
- 10). How do you tag detainees for processing?) (CPA Forces Apprehension Form, two sworn statements, EPW tag) What procedures do you go through? How do you tag equipment? (are they tagged with DD Form 2745)? What about evidence? What procedures do you use to process equipment/evidence? What about confiscated personal affects? Where do you store Detainees' confiscated personal affects (if any)?
- 11). What is your ratio of guards to detainees? Is this ratio the proper mix for you to perform your mission? If not, what are the shortfalls? Why are their shortfalls? How do these shortfalls impact your mission?
- 12). What is the number of personnel needed to maintain security for the detainees until they are processed to a higher collection point?
- 13). What is the number of personnel needed to move prisoners within the holding area (i.e. from one point to another, for medical, evacuation, etc.)?
- 14). How long do you keep detainees at the unit collection point? In relation to the Collection Point, how far away are your ammunition and fuel storage sites? Where is your Tactical Operation Center (TOC)? Where is your screening site where MI Soldiers interrogate Detainees?
- 15). Do you maintain a separate site for sick or wounded Detainees? If so where is it and how does your unit maintain the security and safeguarding of Detainees there? How about female Detainees? How and where do you house them?
- 16). What are the procedures for transporting and evacuating detainees? What procedures are in place to account for or dispose of captured enemy supplies and equipment?
- 17). What transportation problems is the unit experiencing either to move troops or detainees during the operation?
- 18). What is the most important factor that you would address in terms of personnel resources in regards to a successful detainee operation?
- 19). What equipment is the unit experiencing as a shortfall concerning detainee operations, (i.e., restraints, uniforms, CIF items, weapons, etc)?
- 20). How do the Detainees receive fresh water (Bottled water or Lister bag)?

- 21). What types of supplies is greater in-demand for the unit during detainee operations? And are these items regularly filled?
- 22). What procedures are in place when a detainee in U S custody dies?
- 23). Do you know of the procedures to get stress counseling (Psychiatrist, Chaplain, Medical)? Do your Soldiers know of the procedures to get counseling (Psychiatrist, Chaplain, Medical)?
- 24). Are you aware of your requirement to report abuse or suspected abuse of detainees?
- 25). Do your subordinates know the reporting procedures if they observe or become aware of a Detainee being abused?
- 26). What steps would you take if a subordinate reported to you an incident of alleged Detainee abuse?
- 27). Do you feel you can freely report an incident of alleged Detainee abuse outside Command channels (IG, CID)?
- 28). What procedures do you have to report suspected detainee abuse (IG, CID, Next Level Commander)?
- 29). What procedures are in place for detainees to report alleged abuse?
- 30). What do you perceive as the mission of your unit? Describe the importance of your role in that mission.
- 31). Describe your working environment and living conditions since being in Theater.
- 32). Describe the unit command climate and Soldier morale. Has it changed or evolved since you have been in Theater?
- 33). Please provide by show of hands if you aware of any incidences of detainee or other abuse in your unit? (Those that raise their hands, need to be noted and interviewed individually afterwards using the ABUSE QUESTIONNAIRE)

b. SOLDIER (Point of Capture)

- 1). Did you undergo Law of War training prior to deployment? Explain what training occurred. Did this training include the treatment of Detainees? Explain.
- 2). Describe the training/guidance you received to prepare you for handling/guarding the detainees. Does your unit conduct sustainment training for Detainee Operations in Theater? How often does this occur and please describe it? When did your unit last conduct this training?
- 3). What Home Station/Mob Site Training did your unit conduct prior to deployment to help your unit prepare for Detainee Operations? Describe it. (5Ss & T) How did the training

prepare you to conduct Detainee Operations for this deployment? What are your unit's strengths and weaknesses? How did this training distinguish between the different categories of Detainees (EPWs, RPs, CIs, etc.)? What training have you received to ensure your knowledge of DO is IAW the provisions under the Geneva Convention?

- 4). Describe the training you received during Basic Training in handling/processing Detainees. How was it helpful in preparing you for Detainee Operations? How would you improve the training at the schoolhouse?
- 5). How does your unit train on the established Rules of Engagement (ROE)? How often does this occur? Does this training include Rules of Interaction (ROI)? What about Standards of Conduct? (How can you interact with the detainees)? What guidance or policies have you been trained/briefed on to ensure you understand interaction/ fraternization and that it is not taking place between U.S. military personnel and the detainees?
- 6). What procedures has your leadership developed to ensure you understand the use of force and the rules of engagement?
- 7). How is your unit ensuring that all Detainees are protected, safeguarded, and accounted for IAW the 5Ss & T?
- 8). How do you tag detainees for processing (CPA Form, DD Form 2745)? What procedures do you go through? How do you tag equipment (DD Form 2745, DA Form 4137)? What about evidence (DD Form 2745, DA Form 4137)? What procedures do you use to process equipment/evidence? What about confiscated personal affects? Where do you store Detainees' confiscated personal affects (if any)?
- 9). What are the procedures for transporting and evacuating detainees?
- 10). What transportation problems is the unit experiencing either to move troops or detainees during the operation?
- 11). What is the ratio of guards to detainees? Is this ratio the proper mix for you to perform your mission? If not, what are the shortfalls? Why are their shortfalls? How do these shortfalls impact your mission?
- 12). What equipment is the unit experiencing as a shortfall concerning detainee operations, (i.e., restraints, uniforms, CIF items, weapons, etc.)?
- 13). Describe the latrine facilities for Detainees' use (do they have access to it day and night and does it conform to the rules of hygiene and do females have separate facilities). How are they cleaned and how often and by whom? Where do they bathe and conduct other personal hygiene (this will depend how long it takes to evacuate Detainees to CO/BN?
- 14). How do the Detainees receive fresh water (Bottled water or Lister bag)?
- 15). Do you know of the procedures to get stress counseling (Psychiatrist, Chaplain, Medical)?
- 16). Are you aware of your requirement to report abuse or suspected abuse of detainees?

17). Do you feel you can freely report an incident of alleged Detainee abuse outside Command channels (IG, CID)?

18). What procedures do you have to report suspected detainee abuse (IG, CID, Next Level Commander)?

19). What procedures are in place for detainees to report alleged abuse?

20). What do you perceive as the mission of your unit? Describe the importance of your role in that mission.

21). Describe your working environment and living conditions since being in Theater. (Identify physical and psychological impact on Soldier's attitude).

22). Describe the unit command climate and Soldier morale. Has it changed or evolved since you have been in Theater

23). Please provide by show of hands if you aware of any incidences of detainee or other abuse in your unit. (Those that raise their hands, need to be noted and interviewed individually afterwards using the ABUSE QUESTIONNAIRE)

c. GUARD FORCE (NCO) COLLECTION POINT & INTERNMENT FACILITY

1). How did you prepare yourself and your Soldiers to become familiar with and understand the applicable regulations, OPORDS/FRAGOs directives, international laws and administrative procedures to operate an I/R facility or Collection Point?

2). Did you and all of your Soldiers undergo Law of War training prior to deployment? Explain what training occurred. What is your plan to train new Soldiers (replacements) to the unit? Did this training include the treatment of Detainees? Explain.

3). What policies/procedures does your unit have in place to support the U. S. policy relative to the humane treatment of Detainees?

4). Does your unit have a formal training program for the care and control of Detainees? Describe what it includes. (For Permanent Internment Facilities only)

5). What training did your unit receive on the established Rules of Engagement (ROE)? How often does this occur? Does this training include Rules of Interaction (ROI)?

6). What procedures do you have in place to ensure Soldiers understand the use of force and rules of engagement for the interment facility/collection point? What guidance or policies do you have to ensure fraternization is not taking place between U.S. military personnel and the detainees?

7). Describe the training the guard force received to prepare them for their duties (5Ss & T) How does your unit conduct sustainment training for Detainee Operations in Theater? How often does this occur and please describe it? When did your unit last conduct this training?

- 8). What Home Station/Mob Site Training did your unit conduct prior to deployment to help your unit prepare for Detainee Operations? Describe it. How did the training prepare you to conduct Detainee Operations for this deployment? What are your unit's strengths and weaknesses? How did this training distinguish between the different categories of Detainees (EPWs, RPs, CIs, etc.)?
- 9). Describe the training you received during your last Military Institutional School (BNCOC/ANCOC) in handling/processing Detainees. How was it helpful in preparing you for Detainee Operations? How would you improve the training at the schoolhouse?
- 10). What are some of the basic operations of the collection point/internment facility? Is there a copy of the Geneva Convention posted in the detainee's home language within these camps? Are camps segregating Detainees by nationality, language, rank, and sex? How are captured Medical personnel and Chaplains being used in the camps? What provisions are in place for the receipt and distribution of Detainee correspondence/mail? Are the daily food rations sufficient in quantity or quality and variety to keep detainees in good health? Are personal hygiene items and needed clothing being supplied to the Detainees? Are the conditions within the camp sanitary enough to ensure a clean and healthy environment free from disease and epidemics? Is there an infirmary located within the camp?
- 11). What control measures are your unit using to maintain discipline and security in the collection point/internment facility?
- 12). What procedures are in place to account for and dispose of captured enemy supplies and equipment? What procedures are in place to process personnel, equipment, and evidence?
- 13). What is your ratio of guards to detainees in your collection point/internment facility? Is this ratio the proper mix for you to perform your mission? If not, what are the shortfalls? Why are their shortfalls? How do these shortfalls impact your mission?
- 14). How are you organized to handle the different categories of personnel (EPW, CI, OD, females, juveniles and refugees)? Do you maintain a separate site for sick or wounded Detainees? If so where is it and how does your unit maintain the security and safeguarding of Detainees there?
- 15). What is the number of personnel needed to escort prisoners internally and externally? (i.e. for medical, evacuation, etc.)?
- 16). What are the procedures for transporting and evacuating detainees? What are the procedures for transferring Detainees from the collection points to US Military controlled detention facilities? How is the transfer of Detainees handled between different services?
- 17). What are the procedures for the transfer of custody of Detainees from the collection points/internment facility to Military Intelligence/OGA personnel? When the detainee is returned to the guard force, what procedures occur with the detainee? (in processing, medical screening, suicide watch, observation report DD Form 2713?, etc)
- 18). What MP units (guards, escort, detachments) do you have at your disposal to operate and maintain this collection point/internment facility? What non-MP units are you using to help operate this collection point/internment facility? If you do not use MP teams, what forces are required to operate the Collection Point (guard, security etc)? Do you have any shortfalls in

performing the Collection Point mission? How does this affect your doctrinal mission? How long are you holding Detainees at the collection point? Is holding the detainees longer than the 12/24 hours impacting on your units' ability to perform its mission? Why

19). Describe how this unit is able to maintain the security and safeguarding of Detainees at this internment facility/collection point. Describe your security requirements. (What are your clear zones? How do your Guard Towers permit an unobstructed view of the clear zone and how do they allow for overlapping fields of fire? Describe your perimeter security.

20). How do you maintain a high state of discipline with your Soldiers to enhance the internal and external security of the internment facility/Collection Point?

21). Does this facility include Sally Ports? Describe the system in place.

22). What do you have in place for communications (between guards/towers and the TOC/C²)? What problems do you have? How do you overcome them?

23). Describe the latrine facilities for Detainees' use (do they have access to it day and night and does it conform to the rules of hygiene and do females have separate facilities). How are they cleaned and how often and by whom? Where do they bathe and conduct other personal hygiene (this will depend how long it takes to evacuate Detainees to U.S. Military Controlled Detention Facilities—12/24 hours is the standard)?

24). How do the Detainees receive fresh water (Bottled water or Lister bag)?

25). Can you give some examples of contraband? What are the procedures when you find contraband?? (i.e., Knives, Narcotics, weapons, currency)

26). Describe your lighting systems at the Facility/Collection Point (how does it affect security) . How about heating during the winter? What fire prevention/safety measures are in place?

27). How are Detainee complaints and requests to the camp commander processed?

28). What are your shortcomings/problems in feeding the population? What is the menu of the population?

29). What problems, if any, do you feel the unit has regarding manning or personnel resourcing in conducting Detention Operations? What about the number of personnel to control the detention operation in regards to riot control?

30). What personal equipment is the unit experiencing as a shortfall concerning detainee operations, (i.e., restraints, uniforms, CIF items, weapons, etc.)?

31). What types of supplies is greater in-demand for the unit during detainee operations? And are these items regularly filled? What major shortfalls has the unit encountered in regard to materiel and supply distribution?

32). What transportation problems is the unit experiencing to move detainees during the operation?

- 33). What safety programs/policies are currently being used in the Detainee camps?
- 34). Do you know of the procedures to get stress counseling (Psychiatrist, Chaplain, Medical)? Do your Soldiers know of the procedures to get counseling (Psychiatrist, Chaplain, Medical)?
- 35). Are you aware of your requirement to report abuse or suspected abuse of detainees?
- 36). Do your subordinates know the reporting procedures if they observe or become aware of a Detainee being abused?
- 37). What steps would you take if a subordinate reported to you an incident of alleged Detainee abuse?
- 38). Do you feel you can freely report an incident of alleged Detainee abuse outside Command channels (IG, CID)
- 39). What procedures do you have to report suspected detainee abuse (IG, CID, Next Level Commander)?
- 40). What systems are in place for detainees to report alleged abuse?
- 41). What do you perceive as the mission of your unit? Describe the importance of your role in that mission.
- 42). Describe your working environment and living conditions since being in Theater.
- 43). Describe the unit command climate and Soldier morale. Has it changed or evolved since you have been in Theater?
- 44). Please provide by show of hands if you aware of any incidences of detainee or other abuse in your unit? (Those that raise their hands, need to be noted and interviewed individually afterwards using the ABUSE QUESTIONNAIRE)

d. GUARD FORCE (ENLISTED) COLLECTION POINT & INTERNMENT FACILITY

- 1). Did all of you undergo Law of War training prior to deployment? Explain what training occurred. Is there a plan to train new Soldiers (replacements) to the unit? Did this training include the treatment of Detainees? Explain.
- 2). What training have you received to ensure your knowledge of DO is IAW the provisions under the Geneva Convention? (5Ss & T)
- 3). What training did your unit receive on the established Rules of Engagement (ROE)? How often does this occur? Does this training include Rules of Interaction (ROI)?
- 4). Describe the training the guard force received to prepare them for their duties.

- 5). How does your unit conduct sustainment training for Detainee Operations here in Theater? How often does this occur and please describe it? When did your unit last conduct this training?
- 6). (For Permanent Internment Facilities only) Does your unit have a formal training program for the care and control of Detainees? Describe what it includes.
- 7). What Home Station/Mob Site Training did your unit conduct prior to deployment to help your unit prepare for Detainee Operations? Describe it. How did the training prepare you to conduct Detainee Operations for this deployment? How did this training distinguish between the different categories of Detainees (EPWs, RPs, CIs, etc
- 8). What are some of the basic operations of the collection point/facility? Is there a copy of the Geneva Convention posted in the detainee's home language within these camps? Are camps segregating Detainees by nationality, language, rank, and sex? What provisions are in place for the receipt and distribution of Detainee correspondence/mail? Are personal hygiene items and needed clothing being supplied to the Detainees? Are the conditions within the camp sanitary enough to ensure a clean and healthy environment free from disease and epidemics? Is there an infirmary located within the camp?
- 9). What is the maximum capacity for this particular collection point/facility? What is the current Detainee population? What is your ratio of guards to detainees in the collection point/facility? Is this ratio the proper mix for you to perform your mission? If not, what are the shortfalls? Why are their shortfalls? How do these shortfalls impact your mission?
- 10). What control measures are units using to maintain discipline and security in each collection point/facility?
- 11). Describe how this unit is able to maintain the security and safeguarding of Detainees at this collection point/internment facility. Describe your security requirements. (What are your clear zones)? How do your Guard Towers permit an unobstructed view of the clear zone and how do they allow for overlapping fields of fire? Describe your perimeter security.
- 12). What MP units (guards, escort, detachments) do you have at your disposal to operate and maintain this collection point/facility? What non-MP units are you using to help operate this collection point/facility?
- 13). What is the number of personnel that is needed to move prisoners internally and externally, (i.e. for medical, evacuation, etc.)?
- 14). How are you organized to handle the different categories of personnel (EPW, CI, OD, and refugees)? How many female Detainees are housed here? How and where do you house them? How do you maintain separation from the male population (during the day or during recreational activities)? What about other categories (juveniles, CI, RP, etc)? What about other categories (juveniles, CI, RP, etc)? Do you maintain a separate site for sick or wounded Detainees? If so where is it and how does your unit maintain the security and safeguarding of Detainees there?
- 15). (Collection Point only) How long are you holding Detainees at the collection point? Is holding the detainees longer than the 12 hours (FWD CP) or 24 hours (Central CP) impacting on your units' ability to perform its mission? Why?

- 16). What procedures are in place to account for and dispose of captured enemy supplies and equipment?
- 17). Can you give some examples of contraband? What are the procedures when you find contraband?? (i.e., Knives, Narcotics, weapons, currency)
- 18). (Collection Point only) What are the procedures for transporting and evacuating detainees?
- 19). What are the procedures for the transfer of Detainees from the collection points to US Military controlled detention facilities? How is the transfer of Detainees handled between different services?
- 20). What are the procedures for the transfer of custody of Detainees from the collection points/internment facility to Military Intelligence/OGA personnel? When the detainee is returned to the guard force, what procedures occur with the detainee? (in processing, medical screening, suicide watch, observation report DD Form 2713?, etc)
- 21). Does this facility include Sally Ports? Describe the system in place.
- 22). What do you have in place for communications (between guards/towers and the TOC/C²)? What problems do you have?
- 23). How do the Detainees receive fresh water (Bottled water or Lister bag)?
- 24). How are Detainee complaints and requests to the internment facility commander processed?
- 25). What safety programs/policies are currently being used in the internment facilities?
- 26). What personal equipment is the unit experiencing as a shortfall concerning detainee operations, (i.e., restraints, uniforms, CIF items, weapons, etc.)?
- 27). What transportation problems is the unit experiencing either to move troops or detainees during the operation?
- 28). What problems, if any, do you feel the unit has regarding manning or personnel resourcing in conducting Detention Operations?
- 29). Do you know of the procedures to get stress counseling (Psychiatrist, Chaplain, Medical)?
- 30). Are you aware of your requirement to report abuse or suspected abuse of detainees?
- 31). Do you feel you can freely report an incident of alleged Detainee abuse outside Command channels (IG, CID)
- 32). What procedures do you have to report suspected detainee abuse (IG, CID, Next Level Commander)

- 33). What procedures are in place for detainees to report alleged abuse?
- 34). What do you perceive as the mission of your unit? Describe the importance of your role in that mission.
- 35). Describe your working environment and living conditions since being in Theater.
- 36). Describe the unit command climate and Soldier morale. Has it changed or evolved since you have been in Theater?
- 37). Please provide by show of hands if you aware of any incidences of detainee or other abuse in your unit? (Those that raise their hands, need to be noted and interviewed individually afterwards using the ABUSE QUESTIONNAIRE)

e. ABUSE QUESTIONNAIRE.

- 1). What do you perceive as the mission of your unit? Describe the importance of your role in that mission.
- 2). Describe your working environment and living conditions since being in Theater.
- 3). Describe the unit command climate and Soldier morale. Has it changed or evolved since you have been in Theater
- 4). Are you aware of any incidences of detainee or other abuse in your unit?

5). **ADVISEMENT OF RIGHTS (For military personnel)**

The text of Article 31 provides as follows a. No person subject to this chapter may compel any person to incriminate himself or to answer any questions the answer to which may tend to incriminate him. b. No person subject to this chapter may interrogate or request any statement from an accused or a person suspected of an offense without first informing him of the nature of the accusation and advising him that he does not have to make any statement regarding the offense of which he is accused or suspected, and that any statement made by him may be used as evidence against him in a trial by court-martial. c. No person subject to this chapter may compel any person to make a statement or produce evidence before any military tribunal if the statement or evidence is not material to the issue and may tend to degrade him. d. No statement obtained from any person in violation of this article, or through the use of coercion, unlawful influence, or unlawful inducement, may be received in evidence against him in a trial by court-martial. (1.2, 1.6)

6). I am _____(grade, if any, and name), a member of the (DAIG). I am part of a team inspecting detainee operations, this is not a criminal investigation. I am reading you your rights because of a statement you made causes me to suspect that you may have committed _____(specify offense, i.e. aggravated assault, assault, murder). Under Article 31, you have the right to remain silent, that is, say nothing at all. Any statement you make, oral or written, may be used as evidence against you in a trial by courts-martial or in other judicial or administrative proceedings. You have the right to consult a lawyer and to have a lawyer present during this interview. You have the right to military legal counsel free of charge. In addition to military counsel, you are entitled to civilian counsel of your own choosing, at your own expense. You may request a lawyer at any time during this interview. If you decide to answer questions, you may stop the questioning at any time. Do you understand your rights? Do you want a

lawyer? (If the answer is yes, cease all questions at this point). Are you willing to answer questions?

7). Describe what you understand happened leading up to and during the incident(s) of abuse.

8). Describe Soldier morale, feelings and emotional state prior to and after these incidents?

9). Was this incident reported to the chain of command? How, when & what was done? What would you have done?

10). How could the incident have been prevented?

11). Describe any unit training or other programs that you are aware of that teach leaders and Soldiers how to recognize and resolve combat stress.

12). What measures are in place to boost morale or to relieve stress?

13). What measures could the command enact to improve the morale and command climate of your unit?

3. INSPECTION TOOLS.

a. Receipt at the US Military Controlled Detention Facilities Worksheet

UNIT: _____ **DATE:** _____ **NAME:** _____

Receipt at the US Military Controlled Detention Facilities:	
1. What means of transportation are Detainees delivered to the Detention Facility? How are they subdued? Are detainees receiving humane treatment? Are they immediately screened and searched upon arrival? Who is in Charge? (What Unit?)	Remarks:
2. Describe in Detail what the In-Processing Procedures are.	Remarks:
3. Describe in Detail what the Out-Processing Procedures are.	Remarks:
4. Describe security at the Interment Facility. What is the Guard to Detainee Ratio? Describe the Facility in Detail?	

Remarks:					
5. Is the Facility using DA Form 2674-R (Strength Report) to maintain accountability of detainees?	Yes	No	Are the detainees' names listed on this form?	Yes	No
Remarks:					
6. Is the DA 4237-R used for Protected Persons?	Yes	No	Are there children annotated on the form?	Yes	No
Remarks: ((Ask if there compassionate Detainees? (children?))					
7. What paperwork follows the Detainee: Is it completed to standard: If not, why? If not to standard, what happens?					
Remarks:					
8. Did you witness anyone taking photos or films of detainees outside the parameters of internment facilities administration or for intelligence/counterintelligence purposes?	Yes	No			

Remarks:		
9. Are sick or wounded detainees kept separately and in the same manner as US Forces? Does the Facility have an Infirmary? Describe in Detail.	Yes	No
Remarks:		
10. Do detainees enjoy the latitude in the exercise of their religious practices?	Yes	No
Remarks:		
11. Are there interpreters at the Internment Facility? How many? What background checks are conducted?	Yes	No
Remarks:		
12. Are the following forms/requirements being used properly for Civilian Detainees	Yes	No
a. DA Form 1132 (Prisoners Personal Property)	Yes	No
b. DA Form 2677-R (Civilian Internee Identification Card)	Yes	No
c. Are Internment Serial Numbers assigned to each Civilian Internee?	Yes	No
d. DA Form 2678-R (Civilian Internee Notification of Address)	Yes	No
e. DA Form 2663-R (Fingerprint Card) or (BAT Process)	Yes	No
f. or any other forms used (possibly in lieu of) IAW local SOPs or Policy (CPA Apprehension Form?)	Yes	No

Remarks:		
13. What type of unit is in charge of operating the Internment Facility? Is there an adequate number of personnel running the Facility?	Yes	No
Remarks:		
14. Describe physical security at and around the Facility? Describe lighting systems. How about Sally Ports?		
Remarks:		
15. Describe the latrine facilities for Detainees' use. (Do they have access to it day and night and does it conform to the rules of hygiene and do females have separate facilities). How are they cleaned and how often and by whom?		
Remarks:		
16. Describe the furnishings for sleeping and eating (does it include bedding/blankets)? Is there a means to launder clothing items for the Detainees at the Facility		
Remarks:		
17. Describe the Facility's Infrastructure.		
a. Electrical Distribution and Lighting.		
Remarks:		
b. Sewer or Sanitation System (Waste Water, if any).		
Remarks:		
c. Potable Water Supply (drinking).		
Remarks:		

d. Water for bathing and laundry.		
Remarks:		
e. Heating and Ventilation.		
Remarks:		
f. Fire Prevention Measures.		
Remarks:		
g. Segregation based on Detainee Classification.		
Remarks:		
h. Vector/Animal/Pest Control.		
Remarks:		
18. Preventative Medicine Remarks.		
Remarks:		
19. Are Medical Records Maintained for each Detainee? Where are they kept?	Yes	No
Remarks:		
20. Where is the screening site? Where are detainees interrogated? Who interrogates/questions the detainees?		
Remarks:		

19. General Observations: (Include sketch of location/facility area).

SAFETY PROGRAM
 SCREENING/INTERROGATION SITE

ADD RECEIVING/INPROCESSING STATION
 ADD INTERROGATION LOCATION IF APPLICABLE

b. Receipt at the (BDE/DIV) Collection Point to Evacuation to US Military Controlled Detention Facilities Worksheet.

UNIT: _____ DATE: _____ NAME: _____

Receipt at the (BDE/DIV) Collection Point to Evacuation to US Military Controlled Detention Facilities:					
1. Describe security at the Collection Point. What is the Guard to Detainee Ratio?					Ratio:
Remarks:					
2. Is the Collection point using DD Form 629 to maintain accountability of detainees?	Yes	No	Are the detainees' names listed on this list?	Yes	No
Remarks:					
3. Did you witness anyone taking photos or films of detainees outside the parameters of internment facilities administration or for intelligence/counterintelligence purposes?				Yes	No
Remarks:					
4. Describe the Collection Point? Is it located near ammunition sites, fuel facilities, communications equipment, or other potential targets?				Yes	No
Remarks:					

5. Are sick or wounded detainees evacuated separately and in the same manner as US Forces? Are they classified by qualified medical personnel (walking wounded, litter, non-walking wounded)?	Yes	No
Remarks:		
6. Do detainees enjoy the latitude in the exercise of their religious practices?	Yes	No
Remarks:		
7. How long are detainees kept in the Collection point?		
Remarks:		
8. Are escorts provided a DD Form 629 with all the escorted detainees' names listed while evacuating them to US Military Controlled Detention facilities?		
Remarks:		
9. Are there interpreters at the Collection Point?	Yes	No
Remarks:		
10. Are detainees being evacuated to US Military Controlled Detention facilities? How soon after arrival at the CP? Can you describe the process of evacuation?	Yes	No
Remarks:		
11. Is DA Form 4137 being used to account for the detainee's personal property?	Yes	No
Remarks:		
12. What type of unit is in charge of operating the Collection point (MPs or other)? What type of unit does the guard force consist of (MPs or others)? Is there an adequate number of personnel running the Collection Point?	Yes	No
Remarks:		
13. Describe your lighting systems at the Collection Point. How about heating during the winter? What fire prevention/safety measures are in place?		
Remarks:		
14. Describe the latrine facilities for Detainees' use. (Do they have access to it day and night and does it conform to the rules of hygiene and do females have separate facilities). How are they cleaned and how often and by whom? Where do they bathe and conduct other personal hygiene (this will depend how long it takes to evacuate Detainees to U.S. Military Controlled Detention Facilities--12 hours is the standard)?		

Remarks:
15. Describe the furnishings for sleeping and eating (does it include bedding/blankets)? Is there a means to launder clothing items for the Detainees at this Collection Point (this will depend how long it takes to evacuate Detainees to U.S. Military Controlled Detention Facilities-- 12 Hours is the standard).
Remarks:
16. How do the Detainees receive fresh water (Bottled water or Lister bag)? How are they fed (how often and what)?
Remarks:
17. What is the overall Description of the Collection Point? (Hardened Facility, tents, etc)
Remarks:
18. Where is the screening site? Where are detainees interrogated? Who interrogates/questions the detainees?
Remarks:
19. Describe Receiving/In-processing Station.
Remarks:
20. General Observations: (Include sketch of location/facility area).

c. From Capture to the Collection Point Worksheet

UNIT: _____ **DATE:** _____ **NAME:** _____

From Capture to the Collection Point					
1. Are detainees receiving humane treatment?			Yes	No	
Remarks:					
2. Were detainees searched immediately upon capture?			Yes	No	
Remarks:					
3. Was currency confiscated?		Yes	No	Did a commissioned officer approve the confiscation?	
				Yes	No
Remarks:					
4. Were detainees able to keep some personal effects, such as jewelry, protective mask and garments, helmets, clothing, ID Cards, badges of rank/nationality, etc?			Yes	No	
Remarks:					
5. Were the detainees tagged using DD Form 2745? Was the required information entered onto the form (date of capture, grid coordinates of capture, capturing unit, and how the detainee was captured)?			Yes	No	
Remarks:					
6. Is the DD Form 2745 properly divided into Parts A (attached to the detainee), B (retained by the capturing unit), and C (attached to the property of the detainee)?			Yes	No	
Remarks:					
7. What other Forms and in-processing techniques are used and for what (CPA Apprehension Form?)					
Remarks:					
8. Are the detainees being interrogated/questioned soon after being captured? BY WHOM?			Yes	No	
Remarks:					
9. Are wounded detainees receiving medical treatment?			Yes	No	
Remarks:					
10. How are detainees evacuated to the Collection Points and how soon after capture?					
Remarks:					
11. General Observations:					

d. PREVENTIVE MEDICINE SITE ASSESSMENT TOOL (FOR COLLECTION POINTS /
INTERNMENT FACILITIES)

NAME OF CP / FACILITY: _____		TYPE OF CP / FACILITY: _____	
LOCATION (TOWN/CITY, COUNTRY): _____			

DETAINEE POPULATION:	MEN _____	WOMEN _____	

PERSONAL HYGIENE

SHOWERS

NUMBER OF SHOWERS: _____

SOAKAGE PITS / GOOD DRAINAGE / NO STANDING WATER: Y

N

NON-POTABLE WATER SIGNS POSTED IN LOCAL LANGUAGE: Y

N

SOAP / SHAMPOO & TOWELS PRESENT: Y N

CLEANLINESS: POOR FAIR GOOD

EXCELLENT

FREQUENCY OF INSPECTION: DAILY WEEKLY MONTHLY

COMMENTS: _____

HAND WASHING STATIONS

OUTSIDE ALL LATRINES: Y N

IN FOOD SERVICE AREA: Y N

SOAKAGE PITS / GOOD DRAINAGE / NO STANDING WATER: Y

N

SOAP & TOWELS PRESENT: Y

N

NON-POTABLE WATER SIGNS POSTED IN LOCAL LANGUAGE: Y

N

CLEANLINESS: POOR FAIR GOOD

EXCELLENT

FREQUENCY OF INSPECTION: DAILY WEEKLY MONTHLY

COMMENTS: _____

LAUNDRY FACILITIES PRESENT
 ABSENT

SOAKAGE PITS / GOOD DRAINAGE / NO STANDING WATER: Y

N
 NON-POTABLE WATER SIGNS POSTED IN LOCAL LANGUAGE: Y

N
 CLEANLINESS: POOR FAIR GOOD
 EXCELLENT

FREQUENCY OF INSPECTION: DAILY WEEKLY MONTHLY
 COMMENTS: _____

POTABLE WATER SUPPLY

QUANTITY AVAILABLE PER PERSON PER DAY (GALLONS): POTABLE _____
 3-4 gal/person/day potable; 3-15 gal/person/day non-potable NON-

POTABLE _____

WATER SOURCE(S): SURFACE GROUND RAIN ROWPU
 WATER CONTAINERS: 5-GAL CANS FABRIC DRUM
 TRAILER

SOAKAGE PITS / GOOD DRAINAGE / NO STANDING WATER: Y N
 ALL SPIGOTS FUNCTIONAL: Y N
 POTABLE WATER SIGNS POSTED IN LOCAL LANGUAGE: Y N
 CONTAINER CLEANLINESS: POOR FAIR GOOD
 EXCELLENT

FREQUENCY OF INSPECTION: DAILY WEEKLY MONTHLY
 COMMENTS: _____

FOOD SERVICE SANITATION

TYPE OF MEALS PROVIDED: MREs A/B/T RATIONS
 PREPARED

NUMBER OF MEALS SERVED PER DAY: _____

TRANSPORT VEHICLE CLEAN & COMPLETELY COVERED: Y N
 FACILITY CLEANLINESS: POOR FAIR GOOD EXCELLENT

TYPE(S) OF LATRINES: CHEMICAL TRENCH/PIT BURN-OUT
 OTHER
 LATRINES LOCATED 100 YDS DOWNWIND OF FOOD SERVICE: Y N
 LATRINES LOCATED 100 FT FROM GROUND WATER SOURCE(S): Y N
 CLEANLINESS: POOR FAIR GOOD
 EXCELLENT
 FREQUENCY OF INSPECTION: DAILY WEEKLY MONTHLY
 COMMENTS: _____

GARBAGE STORED 100 FT FROM ANY WATER SOURCE: Y N
 GARBAGE IS: BURIED INCINERATED HAULED
 AWAY
 CLEANLINESS: POOR FAIR GOOD
 EXCELLENT
 FREQUENCY OF INSPECTION: DAILY WEEKLY MONTHLY
 COMMENTS: _____

PEST CONTROL

SITE ON HIGH, WELL-DRAINED GROUND: Y N
 SITE AT LEAST 1 MILE FROM STANDING WATER: Y N
 BILLETS SCREENED: Y N
 PESTICIDES AVAILABLE: Y N USED: Y N
 INSECT REPELLENT AVAILABLE: Y N
 SIGHTINGS OF LIVE OR DEAD RODENTS: Y N
 DROPPINGS, GNAWINGS, BURROWS/HOLES, ODORS: Y N
 EVIDENCE OF TRAPS, BAITS, OTHER CONTROLS: Y N
 PRESENCE OF INSECTS: NONE FEW MANY
 TYPE(S) OF INSECTS PRESENT: FLIES MOSQUITOES SAND

FLIES
 FREQUENCY OF INSPECTION: DAILY WEEKLY MONTHLY
 COMMENTS: _____

WORK CONDITIONS

DETAINEES OBSERVED WORKING: Y N
 IF YES: CLOTHING/PROTECTIVE EQUIPMENT APPROPRIATE: Y N
 WET BULB MONITORED BY: UNIT PVNTMED METEOROLOGICAL
 SERVICE
 WORK/REST CYCLES FOLLOWED: Y N
 COMMENTS: _____

QUARTERS (INTERIOR & EXTERIOR)

ADEQUATE SPACE, LIGHTING, CLIMATE CONTROL: Y N
 ADEQUATE LIGHTING: Y N
 ADEQUATE CLIMATE CONTROL: Y N
 EVIDENCE OF RODENTS: Y N
 FOOD DEBRIS/TRASH PRESENT: Y N
 STANDING WATER PRESENT: Y N
 VEGETATION WITHIN XX FT OF QUARTERS: Y N
 CLEANLINESS: POOR FAIR GOOD
 EXCELLENT
 FREQUENCY OF INSPECTION: DAILY WEEKLY MONTHLY
 COMMENTS: _____

FIELD SANITATION TEAM

APPOINTED: Y N TRAINED: Y N
 SUPPLIES: Y N PERFORMING DUTIES: Y N

COLLECT COPIES OF (MOST RECENT? LAST 3?) PVNTMED INSPECTION REPORTS, INCLUDING SITE SURVEYS, FOOD SERVICE SANITATION INSPECTIONS, WATER ANALYSIS, PEST SURVEYS

e. COMBAT / OPERATIONAL STRESS QUESTIONNAIRE

Please answer all questions completely and honestly. Your responses will remain anonymous.

1. Rank E1-4 E5-6 E7-9 O1-3 O4-6
2. Type of Unit PLT CO BN BDE Other

Rate the following statements regarding morale and unit cohesion (1 = strongly disagree, 5 = strongly agree):

- | | |
|--|------------|
| 3. The members of my unit know that they can depend on each other | 1 2 3 4 5 |
| 4. The members of my unit are cooperative with each other | 1 2 3 4 5. |
| 5. The members of my unit stand up for each other | 1 2 3 4 5. |
| 6. The members of my unit were adequately trained for this mission | 1 2 3 4 5 |

Rate the following statements regarding your unit's leadership (1 = never, 5 = always):

- | | |
|---|----------------|
| 7. In your unit, how often do NCOs/officers tell soldiers when they have done a good job? | 1 2 3
4 5 |
| 8. In your unit, how often do NCOs/officers embarrass soldiers in front of other soldiers? | 1 2 3
4 5 |
| 9. In your unit, how often do NCOs/officers try to look good to higher-ups by assigning extra | 1 2 3
3 4 5 |
| missions or details to soldiers? | |
| 10. In your unit, how often do NCOs/officers exhibit clear thinking and reasonable action under stress? | 1 2 3 4 5 |

Rate the following statements regarding access to mental health care (1 = strongly disagree, 5 = strongly agree):

- | | |
|---|-----------|
| 11. I don't know where to get help | 1 2 3 4 5 |
| 12. It is difficult to get an appointment | 1 2 3 4 5 |
| 13. It's too difficult to get to the location where the mental health specialist is | 1 2 3 4 5 |
| 14. I don't trust mental health professionals | 1 2 3 4 5 |
| 15. My leadership would treat me differently | 1 2 3 4 5 |
| 16. My leaders would blame me for the problem | 1 2 3 4 5 |
| 17. I would be seen as weak | 1 2 3 4 5 |

Rate the following statements regarding personal issues at home (1 = strongly disagree, 5 = strongly agree):

- | | |
|--|-----------|
| 18. My relationship with my spouse is very stable | 1 2 3 4 5 |
| 19. My relationship with my spouse makes me happy | 1 2 3 4 5 |
| 20. Do you and/or your spouse have any plans to separate or divorce? | Y N |
| 21. My unit's rear detachment supports my family | 1 2 3 4 5 |
| 22. My unit's family readiness group supports my family | 1 2 3 4 5 |

Combat exposure:

- | | |
|---|---|
| 23. How many times have you been attacked or ambushed? | Never 1-5 times 6-10 times
>10 times |
| 24. How many times have you received small arms fire? | Never 1-5 times 6-10 times
>10 times |
| 25. How many times have you seen dead bodies or human remains? | Never 1-5 times
6-10 times >10 times |
| 26. How many times have you cleared/searched buildings or homes? | Never 1-5 times
6-10 times >10 times |
| 27. How many times have you been responsible for the death of an enemy combatant? | Never
1-5 times 6-10 times >10 times |

Rate the level of concern you have regarding the following (1 = not concerned at all, 5 = very concerned):

- | | | | | | |
|---------------------------------|---|---|---|---|---|
| 28. Being separated from family | 1 | 2 | 3 | 4 | 5 |
| 29. Uncertain redeployment date | 1 | 2 | 3 | 4 | 5 |
| 30. Duration of deployment | 1 | 2 | 3 | 4 | 5 |
| 31. Lack of privacy | 1 | 2 | 3 | 4 | 5 |
| 32. Boring and repetitive work | 1 | 2 | 3 | 4 | 5 |
| 33. Living conditions | 1 | 2 | 3 | 4 | 5 |

Rate the following statements regarding stress management training (1 = strongly disagree, 5 = strongly agree):

- | | | | | | |
|--|---|---|---|---|---|
| 34. My training in handling the stresses of deployment was adequate | 1 | 2 | 3 | 4 | 5 |
| 35. My training in recognizing stress in other soldiers was adequate | 1 | 2 | 3 | 4 | 5 |
- Thank you for your honest responses.

Appendix E

Standards

a. Finding 1:

(1) Finding: All interviewed and observed commanders, leaders, and Soldiers treated detainees humanely and emphasized the importance of the humane treatment of detainees.

(2) Standard: Standard of treatment for detainees in OPERATION ENDURING FREEDOM (OEF): Chairman, Joint Chiefs of Staff (CJCS) message dated 211933Z JAN 02 states that members of the Taliban militia and members of Al Qaida under the control of US Forces would be treated humanely and, to the extent appropriate and consistent with military necessity, in a manner consistent with the principles of the Geneva Conventions of 1949. The DAIG has therefore used the provisions of the Geneva Conventions as a benchmark against which to measure the treatment provided to detainees by U.S. Forces to determine if detainees were treated humanely. The use of these standards as benchmarks does not state or imply a position for the United States or U.S. Army on the legal status of its operations in OEF.

The DAIG refers to 3 key documents in this report. CJCS Message dated 211933Z JAN 02, provides the determination regarding the humane treatment of Al Qaida and Taliban detainees. Convention Relative to the Treatment of Prisoners of War of August 12, 1949 (GPW) is the international treaty that governs the treatment of prisoners of war, and Geneva Convention Relative to the Protection of Civilian Persons in Time of War (GC), 12 August 1949, is the international treaty that governs the treatment of civilian persons in time of war.

As the guidance did not define "humane treatment" but did state that the US would treat members of the Taliban militia and Al Qaida in a manner consistent with the Geneva Conventions, the DAIG determined that it would use Common Article 3 of the GCs as its floor measure of humane treatment, but would also include provisions of the Geneva Convention on the Treatment of Prisoners of War (GPW) and Geneva Convention Relative to the Protection of Civilian Persons in Time of War (GC) as other relevant indicia of "humane treatment." The use of this standard does not state or imply a position for the United States or U.S. Army on the legal status of its operations in OEF.

Standard of treatment for detainees in OPERATION IRAQI FREEDOM (OIF): OIF was an international armed conflict and therefore the provisions of the Geneva Conventions applied. Additionally, the United States was an occupying power and has acted in accordance with the obligations of an occupying power described in the Hague Convention No. IV Respecting the Laws and Customs of War on Land (H.IV), 18 October 1907, including, but not limited to, Articles 43-46 and 50; Geneva Convention Relative to the Treatment of Prisoners of War of August 12, 1949 (GPW), Geneva Convention Relative to the Protection of Civilian Persons in Time of War (GC), 12 August 1949. The GC supplements H.IV, providing the general standard of treatment at Article 27 and specific standards in subsequent Articles.

The minimum treatment provided by Common Article 3 of the Geneva Conventions is: 1) No adverse distinction based upon race, religion, sex, etc.; 2) No violence to life or person; 3) No taking hostages; 4) No degrading treatment; 5) No passing of sentences in absence of fair trial, and; 6) The wounded and sick must be cared for.

The specific language in the CJCS Message for OEF and the GPW/GC and H.IV follows:

CJCS Message dated 211933Z JAN 02, "Paragraph 3. The combatant commanders shall, in detaining Al Qaida and Taliban individuals under the control of the Department of Defense, treat them humanely and, to the extent appropriate and consistent with military necessity, in a manner consistent with the principles of the Geneva Conventions of 1949."

GPW/GC, Article 3 (Common Article 3) – "In the case of armed conflict not of an international character occurring in the territory of one of the High Contracting Parties, each party to the conflict shall be bound to apply, as a minimum, the following provisions:

1. Persons taking no active part in the hostilities, including members of armed forces who have laid down their arms and those placed hors de combat by sickness, wounds, detention, or any other cause, shall in all circumstances be treated humanely, without any adverse distinction founded on race, color, religion or faith, sex, birth or wealth, or any other similar criteria.

To this end the following acts are and shall remain prohibited at any time and in any place whatsoever with respect to the above-mentioned persons:

(a) Violence to life and person, in particular murder of all kinds, mutilation, cruel treatment and torture;
 (b) Taking of hostages;
 (c) Outrages upon personal dignity, in particular, humiliating and degrading treatment;
 (d) The passing of sentences and the carrying out of executions without previous judgment pronounced by a regularly constituted court affording all the judicial guarantees which are recognized as indispensable by civilized peoples.

2. The wounded and sick shall be collected and cared for. An impartial humanitarian body, such as the International Committee of the Red Cross, may offer its services to the Parties to the conflict. The Parties to the conflict should further endeavour to bring into force, by means of special agreements, all or part of the other provisions of the present Convention. The application of the preceding provisions shall not affect the legal status of the Parties to the conflict."

H.IV, Article 43 – "The authority of the legitimate power having in fact passed into the hands of the occupant, the latter shall take all the measures in his power to restore, and ensure, as far as possible, public order and safety, while respecting, unless absolutely prevented, the laws in force in the country.

H.IV, Article 44 – A belligerent is forbidden to force the inhabitants of territory occupied by it to furnish information about the army of the other belligerent, or about its means of defense.

H.IV, Article 45 – It is forbidden to compel the inhabitants of occupied territory to swear allegiance to the hostile Power.

H.IV, Article 46 – Family honour and rights, the lives of persons, and private property, as well as religious convictions and practice, must be respected. Private property cannot be confiscated.

H.IV, Article 47 – Pillage is formally forbidden."

H.IV, Article 50 – "No general penalty, pecuniary or otherwise, shall be inflicted upon the population on account of the acts of individuals for which they cannot be regarded as jointly and severally responsible."

GPW, Article 13 – "Prisoners of war must at all times be humanely treated. Any unlawful act or omission by the Detaining Power causing death or seriously endangering the health of a prisoner of war in its custody is prohibited, and will be regarded as a serious breach of the present Convention. In particular, no prisoner of war may be subjected to physical mutilation or to medical or scientific experiments of any kind which are not justified by the medical, dental or hospital treatment of the prisoner concerned and carried out in his interest. Likewise, prisoners of war must at all times be protected, particularly against acts of violence or intimidation and against insults and public curiosity.

GPW, Article 14 – Prisoners of war are entitled in all circumstances to respect for their persons and their honour. Women shall be treated with all the regard due to their sex and shall in all cases benefit by treatment as favourable as that granted to men. Prisoners of war shall retain the full civil capacity which they enjoyed at the time of their capture. The Detaining Power may not restrict the exercise, either within or without its own territory, of the rights such capacity confers except in so far as the captivity requires.

GPW, Article 15 – The Power detaining prisoners of war shall be bound to provide free of charge for their maintenance and for the medical attention required by their state of health.

GPW, Article 16 – Taking into consideration the provisions of the present Convention relating to rank and sex, and subject to any privileged treatment which may be accorded to them by reason of their state of health, age or professional qualifications, all prisoners of war shall be treated alike by the Detaining Power, without any adverse distinction based on race, nationality, religious belief or political opinions, or any other distinction founded on similar criteria."

GPW, Article 39 – "Every prisoner of war camp shall be put under the immediate authority of a responsible commissioned officer belonging to the regular armed forces of the Detaining Power. Such officer shall have in his possession a copy of the present Convention; he shall ensure that its provisions are known to the camp staff and the guard and shall be responsible, under the direction of his government, for its application. Prisoners of war, with the exception of officers, must salute and show to all officers of the Detaining Power the external marks of respect provided for by the regulations applying in their own forces. Officer prisoners of war are bound to salute only officers of a higher rank of the Detaining Power; they must, however, salute the camp commander regardless of his rank."

GPW, Article 41 – "In every camp the text of the present Convention and its Annexes and the contents of any special agreement provided for in Article 6, shall be posted, in the prisoners' own language, at places where all may read them. Copies shall be supplied, on request, to the prisoners who cannot have access to the copy which has been posted. Regulations, orders, notices and publications of every kind relating to the conduct of prisoners of war shall be issued to them in a language which they understand. Such regulations, orders and publications shall be posted in the manner described above and copies shall be handed to

the prisoners' representative. Every order and command addressed to prisoners of war individually must likewise be given in a language which they understand."

GC, Article 27 – "Protected persons are entitled, in all circumstances, to respect for their persons, their honour, their family rights, their religious convictions and practices, and their manners and customs. They shall at all times be humanely treated, and shall be protected especially against all acts of violence or threats thereof and against insults and public curiosity. Women shall be especially protected against any attack on their honour, in particular against rape, enforced prostitution, or any form of indecent assault. Without prejudice to the provisions relating to their state of health, age and sex, all protected persons shall be treated with the same consideration by the Party to the conflict in whose power they are, without any adverse distinction based, in particular, on race, religion or political opinion. However, the Parties to the conflict may take such measures of control and security in regard to protected persons as may be necessary as a result of the war."

GC, Article 31 – "No physical or moral coercion shall be exercised against protected persons, in particular to obtain information from them or from third parties."

GC, Article 32 – The High Contracting Parties specifically agree that each of them is prohibited from taking any measure of such a character as to cause the physical suffering or extermination of protected persons in their hands. This prohibition applies not only to murder, torture, corporal punishments, mutilation and medical or scientific experiments not necessitated by the medical treatment of a protected person, but also to any other measures of brutality whether applied by civilian or military agents."

GC, Article 37 – "Protected persons who are confined pending proceedings or subject to a sentence involving loss of liberty, shall during their confinement be humanely treated."

GC, Article 41 – "Should the Power, in whose hands protected persons may be, consider the measures of control mentioned in the present Convention to be inadequate, it may not have recourse to any other measure of control more severe than that of assigned residence or internment, in accordance with the provisions of Articles 42 and 43. In applying the provisions of Article 39, second paragraph, to the cases of persons required to leave their usual places of residence by virtue of a decision placing them in assigned residence, by virtue of a decision placing them in assigned residence, elsewhere, the Detaining Power shall be guided as closely as possible by the standards of welfare set forth in Part III, Section IV of this Convention."

GC, Article 42 – The internment or placing in assigned residence of protected persons may be ordered only if the security of the Detaining Power makes it absolutely necessary. If any person, acting through the representatives of the Protecting Power, voluntarily demands internment, and if his situation renders this step necessary, he shall be interned by the Power in whose hands he may be."

GC, Article 43 – Any protected person who has been interned or placed in assigned residence shall be entitled to have such action reconsidered as soon as possible by an appropriate court or administrative board designated by the Detaining Power for that purpose. If the internment or placing in assigned residence is maintained, the court or administrative board shall periodically, and at least twice yearly, give consideration to his or her case, with a view to the favorable amendment of the initial decision, if circumstances permit. Unless the protected persons concerned object, the Detaining Power shall, as rapidly as possible, give the Protecting Power the names of any protected persons who have been interned or subjected to assigned

residence, or who have been released from internment or assigned residence. The decisions of the courts or boards mentioned in the first paragraph of the present Article shall also, subject to the same conditions, be notified as rapidly as possible to the Protecting Power."

GC, Article 68 – "Protected persons who commit an offence which is solely intended to harm the Occupying Power, but which does not constitute an attempt on the life or limb of members of the occupying forces or administration, nor a grave collective danger, nor seriously damage the property of the occupying forces or administration or the installations used by them, shall be liable to internment or simple imprisonment, provided the duration of such internment or imprisonment is proportionate to the offence committed. Furthermore, internment or imprisonment shall, for such offences, be the only measure adopted for depriving protected persons of liberty. The courts provided for under Article 66 of the present Convention may at their discretion convert a sentence of imprisonment to one of internment for the same period.

The penal provisions promulgated by the Occupying Power in accordance with Articles 64 and 65 may impose the death penalty on a protected person only in cases where the person is guilty of espionage, of serious acts of sabotage against the military installations of the Occupying Power or of intentional offences which have caused the death of one or more persons, provided that such offences were punishable by death under the law of the occupied territory in force before the occupation began.

The death penalty may not be pronounced on a protected person unless the attention of the court has been particularly called to the fact that since the accused is not a national of the Occupying Power, he is not bound to it by any duty of allegiance.

In any case, the death penalty may not be pronounced on a protected person who was under eighteen years of age at the time of the offence."

GC, Article 78 – "If the Occupying Power considers it necessary, for imperative reasons of security, to take safety measures concerning protected persons, it may, at the most, subject them to assigned residence or to internment. Decisions regarding such assigned residence or internment shall be made according to a regular procedure to be prescribed by the Occupying Power in accordance with the provisions of the present Convention. This procedure shall include the right of appeal for the parties concerned. Appeals shall be decided with the least possible delay. In the event of the decision being upheld, it shall be subject to periodical review, if possible every six months, by a competent body set up by the said Power. Protected persons made subject to assigned residence and thus required to leave their homes shall enjoy the full benefit of Article 39 of the present Convention.

GC, Article 79 – The Parties to the conflict shall not intern protected persons, except in accordance with the provisions of Articles 41, 42, 43, 68 and 78.

GC, Article 80 – Internees shall retain their full civil capacity and shall exercise such attendant rights as may be compatible with their status."

GC, Article 82 – "The Detaining Power shall, as far as possible, accommodate the internees according to their nationality, language and customs. Internees who are nationals of the same country shall not be separated merely because they have different languages. Throughout the duration of their internment, members of the same family, and in particular parents and children, shall be lodged together in the same place of internment, except when separation of a temporary nature is necessitated for reasons of employment or health or for the

purposes of enforcement of the provisions of Chapter IX of the present Section. Internees may request that their children who are left at liberty without parental care shall be interned with them. Wherever possible, interned members of the same family shall be housed in the same premises and given separate accommodation from other internees, together with facilities for leading a proper family life.

GC, Article 83 – The Detaining Power shall not set up places of internment in areas particularly exposed to the dangers of war. The Detaining Power shall give the enemy Powers, through the intermediary of the Protecting Powers, all useful information regarding the geographical location of places of internment. Whenever military considerations permit, internment camps shall be indicated by the letters IC, placed so as to be clearly visible in the daytime from the air. The Powers concerned may, however, agree upon any other system of marking. No place other than an internment camp shall be marked as such.

GC, Article 84 – Internees shall be accommodated and administered separately from prisoners of war and from persons deprived of liberty for any other reason.

GC, Article 85 – The Detaining Power is bound to take all necessary and possible measures to ensure that protected persons shall, from the outset of their internment, be accommodated in buildings or quarters which afford every possible safeguard as regards hygiene and health, and provide efficient protection against the rigours of the climate and the effects of the war. In no case shall permanent places of internment be situated in unhealthy areas or in districts, the climate of which is injurious to the internees. In all cases where the district, in which a protected person is temporarily interned, is an unhealthy area or has a climate which is harmful to his health, he shall be removed to a more suitable place of internment as rapidly as circumstances permit. The premises shall be fully protected from dampness, adequately heated and lighted, in particular between dusk and lights out. The sleeping quarters shall be sufficiently spacious and well ventilated, and the internees shall have suitable bedding and sufficient blankets, account being taken of the climate, and the age, sex, and state of health of the internees. Internees shall have for their use, day and night, sanitary conveniences which conform to the rules of hygiene, and are constantly maintained in a state of cleanliness. They shall be provided with sufficient water and soap for their daily personal toilet and for washing their personal laundry; installations and facilities necessary for this purpose shall be granted to them. Showers or baths shall also be available. The necessary time shall be set aside for washing and for cleaning. Whenever it is necessary, as an exceptional and temporary measure, to accommodate women internees who are not members of a family unit in the same place of internment as men, the provision of separate sleeping quarters and sanitary conveniences for the use of such women internees shall be obligatory.

GC, Article 86 – The Detaining Power shall place at the disposal of interned persons, of whatever denomination, premises suitable for the holding of their religious services."

GC, Article 88 – "In all places of internment exposed to air raids and other hazards of war, shelters adequate in number and structure to ensure the necessary protection shall be installed. In case of alarms, the internees shall be free to enter such shelters as quickly as possible, excepting those who remain for the protection of their quarters against the aforesaid hazards. Any protective measures taken in favour of the population shall also apply to them. All due precautions must be taken in places of internment against the danger of fire.

GC, Article 89 – Daily food rations for internees shall be sufficient in quantity, quality and variety to keep internees in a good state of health and prevent the development of nutritional

deficiencies. Account shall also be taken of the customary diet of the internees. Internees shall also be given the means by which they can prepare for themselves any additional food in their possession. Sufficient drinking water shall be supplied to internees. The use of tobacco shall be permitted. Internees who work shall receive additional rations in proportion to the kind of labour which they perform. Expectant and nursing mothers and children under fifteen years of age, shall be given additional food, in proportion to their physiological needs.

GC, Article 90 – When taken into custody, internees shall be given all facilities to provide themselves with the necessary clothing, footwear and change of underwear, and later on, to procure further supplies if required. Should any internees not have sufficient clothing, account being taken of the climate, and be unable to procure any, it shall be provided free of charge to them by the Detaining Power. The clothing supplied by the Detaining Power to internees and the outward markings placed on their own clothes shall not be ignominious nor expose them to ridicule. Workers shall receive suitable working outfits, including protective clothing, whenever the nature of their work so requires."

GC, Article 93 – "Internees shall enjoy complete latitude in the exercise of their religious duties, including attendance at the services of their faith, on condition that they comply with the disciplinary routine prescribed by the detaining authorities."

GC, Article 97 – "Internees shall be permitted to retain articles of personal use. Monies, cheques, bonds, etc., and valuables in their possession may not be taken from them except in accordance with established procedure. Detailed receipts shall be given therefor. The amounts shall be paid into the account of every internee as provided for in Article 98. Such amounts may not be converted into any other currency unless legislation in force in the territory in which the owner is interned so requires or the internee gives his consent. Articles which have above all a personal or sentimental value may not be taken away. A woman internee shall not be searched except by a woman. On release or repatriation, internees shall be given all articles, monies or other valuables taken from them during internment and shall receive in currency the balance of any credit to their accounts kept in accordance with Article 98, with the exception of any articles or amounts withheld by the Detaining Power by virtue of its legislation in force. If the property of an internee is so withheld, the owner shall receive a detailed receipt. Family or identity documents in the possession of internees may not be taken away without a receipt being given. At no time shall internees be left without identity documents. If they have none, they shall be issued with special documents drawn up by the detaining authorities, which will serve as their identity papers until the end of their internment. Internees may keep on their persons a certain amount of money, in cash or in the shape of purchase coupons, to enable them to make purchases."

GC, Article 99 – "Every place of internment shall be put under the authority of a responsible officer, chosen from the regular military forces or the regular civil administration of the Detaining Power. The officer in charge of the place of internment must have in his possession a copy of the present Convention in the official language, or one of the official languages, of his country and shall be responsible for its application. The staff in control of internees shall be instructed in the provisions of the present Convention and of the administrative measures adopted to ensure its application. The text of the present Convention and the texts of special agreements concluded under the said Convention shall be posted inside the place of internment, in a language which the internees understand, or shall be in the possession of the Internee Committee. Regulations, orders, notices and publications of every kind shall be communicated to the internees and posted inside the places of internment in a

language which they understand. Every order and command addressed to internees individually must, likewise, be given in a language which they understand."

GC, Article 100 – "The disciplinary regime in places of internment shall be consistent with humanitarian principles, and shall in no circumstances include regulations imposing on internees any physical exertion dangerous to their health or involving physical or moral victimization. Identification by tattooing or imprinting signs or markings on the body, is prohibited. In particular, prolonged standing and roll-calls, punishment drill, military drill and manoeuvres, or the reduction of food rations, are prohibited."

Army Regulation 190-8, Enemy Prisoners of War, Retained Personnel, Civilian Internees and Other Detainees, 1 October 1997, Chapter 1, paragraph 1-1, subparagraphs a and b. This regulation is a multi-service regulation implementing DOD Directive 2310.1 and incorporates Army Regulation 190-8 and 190-57 and SECNAV Instruction 3461.3, and Air Force Joint Instruction 31-304 and outlines policies, procedures, and responsibilities for treatment of enemy prisoners of war (EPW), retained personnel (RP), civilian internees (CI), and other detainees (OD) and implements international law for all military operations. The specific language in the regulation follows:

"1-1. Purpose

a. This regulation provides policy, procedures, and responsibilities for the administration, treatment, employment, and compensation of enemy prisoners of war (EPW), retained personnel (RP), civilian internees (CI) and other detainees (OD) in the custody of U.S. Armed Forces. This regulation also establishes procedures for transfer of custody from the United States to another detaining power.

b. This regulation implements international law, both customary and codified, relating to EPW, RP, CI, and ODs which includes those persons held during military operations other than war."

b. Finding 2:

(1) Finding: In the cases the DAIG reviewed, all detainee abuse occurred when one or more individuals failed to adhere to basic standards of discipline, training, or Army Values; in some cases abuse was accompanied by leadership failure at the tactical level.

(2) Standard: Standard of treatment for detainees in OPERATION ENDURING FREEDOM (OEF): Guidance was provided stating that members of the Taliban militia and members of Al Qaida under the control of U.S. Forces would be treated humanely and, to the extent appropriate and consistent with military necessity, in a manner consistent with the principles of the Geneva Conventions of 1949. The DAIG has therefore used the provisions of the Geneva Conventions as a benchmark against which to measure the treatment provided to detainees by U.S. Forces to determine if detainees were treated humanely. The use of these standards as benchmarks does not state or imply a position for the United States or U.S. Army on the legal status of its operations in OEF.

Chairman, Joint Chiefs of Staff (CJCS) Message dated 211933Z JAN 02, provides the determination regarding the humane treatment of Al Qaida and Taliban detainees. Convention Relative to the Treatment of Prisoners of War of August 12, 1949 (GPW) is the international treaty that governs the treatment of prisoners of war), and Geneva Convention Relative to the

Protection of Civilian Persons in Time of War (GC), August 12, 1949 is the international treaty that governs the treatment of civilian persons in time of war.

As the guidance did not define "humane treatment" but did state that the U.S. would treat members of the Taliban militia and Al Qaida in a manner consistent with the Geneva Conventions, the DAIG determined that it would use Common Article 3 of the GCs as its floor measure of humane treatment, but would also include provisions of the Geneva Convention on the Treatment of Prisoners of War (GPW) and Geneva Convention Relative to the Protection of Civilian Persons in Time of War (GC) as other relevant indicia of "humane treatment." The use of this standard does not state or imply a position for the United States or U.S. Army on the legal status of its operations in OEF.

Standard of treatment for detainees in OPERATION IRAQI FREEDOM (OIF): OIF was an international armed conflict and therefore the provisions of the Geneva Conventions applied. Additionally, the United States was an occupying power and has acted in accordance with the obligations of an occupying power described in the Hague Convention No. IV Respecting the Laws and Customs of War on Land (H.IV), Oct. 18, 1907, including, but not limited to, Articles 43-46 and 50; Geneva Convention Relative to the Treatment of Prisoners of War of August 12, 1949 (GPW); and Geneva Convention Relative to the Protection of Civilian Persons in Time of War (GC), August 12, 1949. The GC supplements H.IV, providing the general standard of treatment at Article 27 and specific standards in subsequent Articles.

The minimum treatment provided by Common Article 3 of the Geneva Conventions is: (1) No adverse distinction based upon race, religion, sex, etc.; (2) No violence to life or person; (3) No taking hostages; (4) No degrading treatment; (5) No passing of sentences in absence of fair trial, and; (6) The wounded and sick must be cared for.

The specific language in the CJCS Message for OEF and the GPW/GC and H.IV follows:

CJCS Message dated 211933Z JAN 02, "Paragraph 3. The combatant commanders shall, in detaining Al Qaida and Taliban individuals under the control of the Department of Defense, treat them humanely and, to the extent appropriate and consistent with military necessity, in a manner consistent with the principles of the Geneva Conventions of 1949."

GPW/GC, Article 3 (Common Article 3) – "In the case of armed conflict not of an international character occurring in the territory of one of the High Contracting Parties, each party to the conflict shall be bound to apply, as a minimum, the following provisions:

1. Persons taking no active part in the hostilities, including members of armed forces who have laid down their arms and those placed hors de combat by sickness, wounds, detention, or any other cause, shall in all circumstances be treated humanely, without any adverse distinction founded on race, color, religion or faith, sex, birth or wealth, or any other similar criteria.

To this end the following acts are and shall remain prohibited at any time and in any place whatsoever with respect to the above-mentioned persons:

- (a) Violence to life and person, in particular murder of all kinds, mutilation, cruel treatment and torture;
- (b) Taking of hostages;

(c) Outrages upon personal dignity, in particular, humiliating and degrading treatment;
 (d) The passing of sentences and the carrying out of executions without previous judgment pronounced by a regularly constituted court affording all the judicial guarantees which are recognized as indispensable by civilized peoples.

2. The wounded and sick shall be collected and cared for. An impartial humanitarian body, such as the International Committee of the Red Cross, may offer its services to the Parties to the conflict. The Parties to the conflict should further endeavour to bring into force, by means of special agreements, all or part of the other provisions of the present Convention. The application of the preceding provisions shall not affect the legal status of the Parties to the conflict."

GPW, Article 13 – "Prisoners of war must at all times be humanely treated. Any unlawful act or omission by the Detaining Power causing death or seriously endangering the health of a prisoner of war in its custody is prohibited, and will be regarded as a serious breach of the present Convention. In particular, no prisoner of war may be subjected to physical mutilation or to medical or scientific experiments of any kind which are not justified by the medical, dental or hospital treatment of the prisoner concerned and carried out in his interest. Likewise, prisoners of war must at all times be protected, particularly against acts of violence or intimidation and against insults and public curiosity."

GPW, Article 14 – Prisoners of war are entitled in all circumstances to respect for their persons and their honour. Women shall be treated with all the regard due to their sex and shall in all cases benefit by treatment as favourable as that granted to men. Prisoners of war shall retain the full civil capacity which they enjoyed at the time of their capture. The Detaining Power may not restrict the exercise, either within or without its own territory, of the rights such capacity confers except in so far as the captivity requires.

GPW, Article 15 – The Power detaining prisoners of war shall be bound to provide free of charge for their maintenance and for the medical attention required by their state of health.

GPW, Article 16 – Taking into consideration the provisions of the present Convention relating to rank and sex, and subject to any privileged treatment which may be accorded to them by reason of their state of health, age or professional qualifications, all prisoners of war shall be treated alike by the Detaining Power, without any adverse distinction based on race, nationality, religious belief or political opinions, or any other distinction founded on similar criteria."

GPW, Article 39 – "Every prisoner of war camp shall be put under the immediate authority of a responsible commissioned officer belonging to the regular armed forces of the Detaining Power. Such officer shall have in his possession a copy of the present Convention; he shall ensure that its provisions are known to the camp staff and the guard and shall be responsible, under the direction of his government, for its application. Prisoners of war, with the exception of officers, must salute and show to all officers of the Detaining Power the external marks of respect provided for by the regulations applying in their own forces. Officer prisoners of war are bound to salute only officers of a higher rank of the Detaining Power; they must, however, salute the camp commander regardless of his rank."

GPW, Article 41 – "In every camp the text of the present Convention and its Annexes and the contents of any special agreement provided for in Article 6, shall be posted, in the prisoners' own language, at places where all may read them. Copies shall be supplied, on request, to the prisoners who cannot have access to the copy which has been posted.

Regulations, orders, notices and publications of every kind relating to the conduct of prisoners of war shall be issued to them in a language which they understand. Such regulations, orders and publications shall be posted in the manner described above and copies shall be handed to the prisoners' representative. Every order and command addressed to prisoners of war individually must likewise be given in a language which they understand."

GC, Article 27 – "Protected persons are entitled, in all circumstances, to respect for their persons, their honour, their family rights, their religious convictions and practices, and their manners and customs. They shall at all times be humanely treated, and shall be protected especially against all acts of violence or threats thereof and against insults and public curiosity. Women shall be especially protected against any attack on their honour, in particular against rape, enforced prostitution, or any form of indecent assault. Without prejudice to the provisions relating to their state of health, age and sex, all protected persons shall be treated with the same consideration by the Party to the conflict in whose power they are, without any adverse distinction based, in particular, on race, religion or political opinion. However, the Parties to the conflict may take such measures of control and security in regard to protected persons as may be necessary as a result of the war."

GC, Article 31 – "No physical or moral coercion shall be exercised against protected persons, in particular to obtain information from them or from third parties.

GC, Article 32 – The High Contracting Parties specifically agree that each of them is prohibited from taking any measure of such a character as to cause the physical suffering or extermination of protected persons in their hands. This prohibition applies not only to murder, torture, corporal punishments, mutilation and medical or scientific experiments not necessitated by the medical treatment of a protected person, but also to any other measures of brutality whether applied by civilian or military agents."

GC, Article 37 – "Protected persons who are confined pending proceedings or subject to a sentence involving loss of liberty, shall during their confinement be humanely treated."

GC, Article 41 – "Should the Power, in whose hands protected persons may be, consider the measures of control mentioned in the present Convention to be inadequate, it may not have recourse to any other measure of control more severe than that of assigned residence or internment, in accordance with the provisions of Articles 42 and 43. In applying the provisions of Article 39, second paragraph, to the cases of persons required to leave their usual places of residence by virtue of a decision placing them in assigned residence, by virtue of a decision placing them in assigned residence, elsewhere, the Detaining Power shall be guided as closely as possible by the standards of welfare set forth in Part III, Section IV of this Convention.

GC, Article 42 – The internment or placing in assigned residence of protected persons may be ordered only if the security of the Detaining Power makes it absolutely necessary. If any person, acting through the representatives of the Protecting Power, voluntarily demands internment, and if his situation renders this step necessary, he shall be interned by the Power in whose hands he may be.

GC, Article 43 – Any protected person who has been interned or placed in assigned residence shall be entitled to have such action reconsidered as soon as possible by an appropriate court or administrative board designated by the Detaining Power for that purpose. If the internment or placing in assigned residence is maintained, the court or administrative board shall periodically, and at least twice yearly, give consideration to his or her case, with a view to

the favorable amendment of the initial decision, if circumstances permit. Unless the protected persons concerned object, the Detaining Power shall, as rapidly as possible, give the Protecting Power the names of any protected persons who have been interned or subjected to assigned residence, or who have been released from internment or assigned residence. The decisions of the courts or boards mentioned in the first paragraph of the present Article shall also, subject to the same conditions, be notified as rapidly as possible to the Protecting Power."

GC, Article 68 – "Protected persons who commit an offence which is solely intended to harm the Occupying Power, but which does not constitute an attempt on the life or limb of members of the occupying forces or administration, nor a grave collective danger, nor seriously damage the property of the occupying forces or administration or the installations used by them, shall be liable to internment or simple imprisonment, provided the duration of such internment or imprisonment is proportionate to the offence committed. Furthermore, internment or imprisonment shall, for such offences, be the only measure adopted for depriving protected persons of liberty. The courts provided for under Article 66 of the present Convention may at their discretion convert a sentence of imprisonment to one of internment for the same period.

The penal provisions promulgated by the Occupying Power in accordance with Articles 64 and 65 may impose the death penalty on a protected person only in cases where the person is guilty of espionage, of serious acts of sabotage against the military installations of the Occupying Power or of intentional offences which have caused the death of one or more persons, provided that such offences were punishable by death under the law of the occupied territory in force before the occupation began.

The death penalty may not be pronounced on a protected person unless the attention of the court has been particularly called to the fact that since the accused is not a national of the Occupying Power, he is not bound to it by any duty of allegiance.

In any case, the death penalty may not be pronounced on a protected person who was under eighteen years of age at the time of the offence."

GC, Article 78 – "If the Occupying Power considers it necessary, for imperative reasons of security, to take safety measures concerning protected persons, it may, at the most, subject them to assigned residence or to internment. Decisions regarding such assigned residence or internment shall be made according to a regular procedure to be prescribed by the Occupying Power in accordance with the provisions of the present Convention. This procedure shall include the right of appeal for the parties concerned. Appeals shall be decided with the least possible delay. In the event of the decision being upheld, it shall be subject to periodical review, if possible every six months, by a competent body set up by the said Power. Protected persons made subject to assigned residence and thus required to leave their homes shall enjoy the full benefit of Article 39 of the present Convention.

GC, Article 79 – The Parties to the conflict shall not intern protected persons, except in accordance with the provisions of Articles 41, 42, 43, 68 and 78.

GC, Article 80 – Internees shall retain their full civil capacity and shall exercise such attendant rights as may be compatible with their status."

GC, Article 82 – "The Detaining Power shall, as far as possible, accommodate the internees according to their nationality, language and customs. Internees who are nationals of the same country shall not be separated merely because they have different languages.

Throughout the duration of their internment, members of the same family, and in particular parents and children, shall be lodged together in the same place of internment, except when separation of a temporary nature is necessitated for reasons of employment or health or for the purposes of enforcement of the provisions of Chapter IX of the present Section. Internees may request that their children who are left at liberty without parental care shall be interned with them. Wherever possible, interned members of the same family shall be housed in the same premises and given separate accommodation from other internees, together with facilities for leading a proper family life.

GC, Article 83 – The Detaining Power shall not set up places of internment in areas particularly exposed to the dangers of war. The Detaining Power shall give the enemy Powers, through the intermediary of the Protecting Powers, all useful information regarding the geographical location of places of internment. Whenever military considerations permit, internment camps shall be indicated by the letters IC, placed so as to be clearly visible in the daytime from the air. The Powers concerned may, however, agree upon any other system of marking. No place other than an internment camp shall be marked as such.

GC, Article 84 – Internees shall be accommodated and administered separately from prisoners of war and from persons deprived of liberty for any other reason.

GC, Article 85 – The Detaining Power is bound to take all necessary and possible measures to ensure that protected persons shall, from the outset of their internment, be accommodated in buildings or quarters which afford every possible safeguard as regards hygiene and health, and provide efficient protection against the rigours of the climate and the effects of the war. In no case shall permanent places of internment be situated in unhealthy areas or in districts, the climate of which is injurious to the internees. In all cases where the district, in which a protected person is temporarily interned, is an unhealthy area or has a climate which is harmful to his health, he shall be removed to a more suitable place of internment as rapidly as circumstances permit. The premises shall be fully protected from dampness, adequately heated and lighted, in particular between dusk and lights out. The sleeping quarters shall be sufficiently spacious and well ventilated, and the internees shall have suitable bedding and sufficient blankets, account being taken of the climate, and the age, sex, and state of health of the internees. Internees shall have for their use, day and night, sanitary conveniences which conform to the rules of hygiene, and are constantly maintained in a state of cleanliness. They shall be provided with sufficient water and soap for their daily personal toilet and for washing their personal laundry; installations and facilities necessary for this purpose shall be granted to them. Showers or baths shall also be available. The necessary time shall be set aside for washing and for cleaning. Whenever it is necessary, as an exceptional and temporary measure, to accommodate women internees who are not members of a family unit in the same place of internment as men, the provision of separate sleeping quarters and sanitary conveniences for the use of such women internees shall be obligatory.

GC, Article 86 – The Detaining Power shall place at the disposal of interned persons, of whatever denomination, premises suitable for the holding of their religious services."

GC, Article 88 – "In all places of internment exposed to air raids and other hazards of war, shelters adequate in number and structure to ensure the necessary protection shall be installed. In case of alarms, the internees shall be free to enter such shelters as quickly as possible, excepting those who remain for the protection of their quarters against the aforesaid hazards. Any protective measures taken in favour of the population shall also apply to them. All due precautions must be taken in places of internment against the danger of fire.

GC, Article 89 – Daily food rations for internees shall be sufficient in quantity, quality and variety to keep internees in a good state of health and prevent the development of nutritional deficiencies. Account shall also be taken of the customary diet of the internees. Internees shall also be given the means by which they can prepare for themselves any additional food in their possession. Sufficient drinking water shall be supplied to internees. The use of tobacco shall be permitted. Internees who work shall receive additional rations in proportion to the kind of labour which they perform. Expectant and nursing mothers and children under fifteen years of age, shall be given additional food, in proportion to their physiological needs.

GC, Article 90 – When taken into custody, internees shall be given all facilities to provide themselves with the necessary clothing, footwear and change of underwear, and later on, to procure further supplies if required. Should any internees not have sufficient clothing, account being taken of the climate, and be unable to procure any, it shall be provided free of charge to them by the Detaining Power. The clothing supplied by the Detaining Power to internees and the outward markings placed on their own clothes shall not be ignominious nor expose them to ridicule. Workers shall receive suitable working outfits, including protective clothing, whenever the nature of their work so requires."

GC, Article 93 – "Internees shall enjoy complete latitude in the exercise of their religious duties, including attendance at the services of their faith, on condition that they comply with the disciplinary routine prescribed by the detaining authorities."

GC, Article 97 – "Internees shall be permitted to retain articles of personal use. Monies, cheques, bonds, etc., and valuables in their possession may not be taken from them except in accordance with established procedure. Detailed receipts shall be given therefor. The amounts shall be paid into the account of every internee as provided for in Article 98. Such amounts may not be converted into any other currency unless legislation in force in the territory in which the owner is interned so requires or the internee gives his consent. Articles which have above all a personal or sentimental value may not be taken away. A woman internee shall not be searched except by a woman. On release or repatriation, internees shall be given all articles, monies or other valuables taken from them during internment and shall receive in currency the balance of any credit to their accounts kept in accordance with Article 98, with the exception of any articles or amounts withheld by the Detaining Power by virtue of its legislation in force. If the property of an internee is so withheld, the owner shall receive a detailed receipt. Family or identity documents in the possession of internees may not be taken away without a receipt being given. At no time shall internees be left without identity documents. If they have none, they shall be issued with special documents drawn up by the detaining authorities, which will serve as their identity papers until the end of their internment. Internees may keep on their persons a certain amount of money, in cash or in the shape of purchase coupons, to enable them to make purchases."

GC, Article 99 – "Every place of internment shall be put under the authority of a responsible officer, chosen from the regular military forces or the regular civil administration of the Detaining Power. The officer in charge of the place of internment must have in his possession a copy of the present Convention in the official language, or one of the official languages, of his country and shall be responsible for its application. The staff in control of internees shall be instructed in the provisions of the present Convention and of the administrative measures adopted to ensure its application. The text of the present Convention and the texts of special agreements concluded under the said Convention shall be posted inside the place of internment, in a language which the internees understand, or shall be in the

possession of the Internee Committee. Regulations, orders, notices and publications of every kind shall be communicated to the internees and posted inside the places of internment in a language which they understand. Every order and command addressed to internees individually must, likewise, be given in a language which they understand."

GC, Article 100 – "The disciplinary regime in places of internment shall be consistent with humanitarian principles, and shall in no circumstances include regulations imposing on internees any physical exertion dangerous to their health or involving physical or moral victimization. Identification by tattooing or imprinting signs or markings on the body, is prohibited. In particular, prolonged standing and roll-calls, punishment drill, military drill and manoeuvres, or the reduction of food rations, are prohibited."

H.IV, Article 43 – "The authority of the legitimate power having in fact passed into the hands of the occupant, the latter shall take all the measures in his power to restore, and ensure, as far as possible, public order and safety, while respecting, unless absolutely prevented, the laws in force in the country.

H.IV, Article 44 – A belligerent is forbidden to force the inhabitants of territory occupied by it to furnish information about the army of the other belligerent, or about its means of defense.

H.IV, Article 45 – It is forbidden to compel the inhabitants of occupied territory to swear allegiance to the hostile Power.

H.IV, Article 46 – Family honour and rights, the lives of persons, and private property, as well as religious convictions and practice, must be respected. Private property cannot be confiscated.

H.IV, Article 47 – Pillage is formally forbidden."

H.IV, Article 50 – "No general penalty, pecuniary or otherwise, shall be inflicted upon the population on account of the acts of individuals for which they cannot be regarded as jointly and severally responsible."

Army Regulation (AR) 190-8, Enemy Prisoners of War, Retained Personnel, Civilian Internees and Other Detainees, 1 October 1997, Chapter 1, paragraphs 1-5, subparagraphs *a*, *b*, and *c*; paragraph 2-1, subparagraph *a (1)(d)*; and paragraph 5-1, subparagraph (6), provides instruction on the overall treatment of detainees. This regulation is a multi-service regulation implementing DOD Directive 2310.1 and incorporates Army Regulation 190-8 and 190-57 and SECNAV Instruction 3461.3, and Air Force Joint Instruction 31-304 and outlines policies, procedures, and responsibilities for treatment of enemy prisoners of war (EPW), retained personnel (RP), civilian internees (CI), and other detainees (OD) and implements international law for all military operations. The specific language in the regulation follows:

"1-5. General protection policy

a. U.S. policy, relative to the treatment of EPW, CI and RP in the custody of the U.S. Armed Forces, is as follows:

(1) All persons captured, detained, interned, or otherwise held in U.S. Armed Forces custody during the course of conflict will be given humanitarian care and treatment from the moment they fall into the hands of U.S. forces until final release or repatriation."

"(4) The inhumane treatment of EPW, CI, RP is prohibited and is not justified by the stress of combat or with deep provocation. Inhumane treatment is a serious and punishable violation under international law and the Uniform Code of Military Justice (UCMJ)."

"b. All prisoners will receive humane treatment without regard to race, nationality, religion, political opinion, sex, or other criteria. The following acts are prohibited: murder, torture, corporal punishment, mutilation, the taking of hostages, sensory deprivation, collective punishments, execution without trial by proper authority, and all cruel and degrading treatment.

c. All persons will be respected as human beings. They will be protected against all acts of violence to include rape, forced prostitution, assault and theft, insults, public curiosity, bodily injury, and reprisals of any kind. They will not be subjected to medical or scientific experiments. This list is not exclusive. EPW/RP is to be protected from all threats or acts of violence."

"2-1. a. (1) (d) Prisoners may be interrogated in the combat zone. The use of physical or mental torture or any coercion to compel prisoners to provide information is prohibited.... Prisoners may not be threatened, insulted, or exposed to unpleasant or disparate treatment of any kind because of their refusal to answer questions."

"5-1 (6) The following acts are specifically prohibited:

(a) Any measures of such character as to cause the physical suffering or extermination of the CI. This prohibition applies not only to murder, torture, corporal punishment, mutilation, and medical or scientific experiments, but also to any other measure of brutality.

(b) Punishment of the CI for an offense they did not personally commit.

(c) Collective penalties and all measures of intimidation and terrorism against the CI.

(d) Reprisals against the CI and their property.

(e) The taking and holding of the CI as hostages."

AR 600-20, Army Command Policy, Chapter 1, paragraph 1-5, subparagraph c (1), and (4), prescribes the policies and responsibilities of command. The specific language in the regulation follows:

"c. Characteristics of command leadership.

The commander is responsible for establishing leadership climate of the unit and developing disciplined and cohesive units. This sets the parameters within which command will be exercised and, therefore, sets the tone for social and duty relationships within the command. Commanders are also responsible for the professional development of their soldiers. To this end, they encourage self-study, professional development, and continued growth of their subordinates' military careers.

(1) Commanders and other leaders committed to the professional Army ethic promote a positive environment. If leaders show loyalty to their soldiers, the Army, and the Nation, they

earn the loyalty of their soldiers. If leaders consider their soldiers' needs and care for their well-being, and if they demonstrate genuine concern, these leaders build a positive command climate."

"(4) Professionally competent leaders will develop respect for their authority by-

(a) Striving to develop, maintain, and use the full range of human potential in their organization. This potential is a critical factor in ensuring that the organization is capable of accomplishing its mission.

(b) Giving troops constructive information on the need for and purpose of military discipline. Articles in the UCMJ which require explanation will be presented in such a way to ensure that soldiers are fully aware of the controls and obligations imposed on them by virtue of their military service. (See Art 137, UCMJ.)

(c) Properly training their soldiers and ensuring that both soldiers and equipment are in the proper state of readiness at all times. Commanders should assess the command climate periodically to analyze the human dimension of combat readiness. Soldiers must be committed to accomplishing the mission through the unit cohesion developed as a result of a healthy leadership climate established by the command. Leaders at all levels promote the individual readiness of their soldiers by developing competence and confidence in their subordinates. In addition to being mentally, physically, tactically, and technically competent, soldiers must have confidence in themselves, their equipment, their peers, and their leaders. A leadership climate in which all soldiers are treated with fairness, justice, and equity will be crucial to development of this confidence within soldiers. Commanders are responsible for developing disciplined and cohesive units sustained at the highest readiness level possible."

c. Finding 3:

(1) Finding: Of all facilities inspected, only Abu Ghraib was determined to be undesirable for housing detainees because it is located near an urban population and is under frequent hostile fire, placing Soldiers and detainees at risk.

(2) Standard: Hague Convention No. IV Respecting the Laws and Customs of War on Land (H.IV), Oct. 18, 1907, Articles 43-46 and 50; and Geneva Convention Relative to the Protection of Civilian Persons in Time of War (GC), Aug 12, 1949, Articles 81, 83, 85, 88, 89, and 91 discuss the requirement to accommodate detainees in buildings or quarters which afford every possible safeguard regarding health and hygiene and the effects of war. The specific language in the GC follows:

GC Article 81 – "Parties to the conflict who intern protected persons shall be bound to provide free of charge for their maintenance, and to grant them also the medical attention required by their state of health. No deduction from the allowances, salaries or credits due to the internees shall be made for the repayment of these costs.

GC, Article 83 – "The Detaining Power shall not set up places of internment in areas particularly exposed to the dangers of war. ...

GC, Article 84 – Internees shall be accommodated and administered separately from prisoners of war and from persons deprived of liberty for any other reason.

GC, Article 85 – The Detaining Power is bound to take all necessary and possible measures to ensure that protected persons shall, from the outset of their internment, be accommodated in buildings or quarters which afford every possible safeguard as regards hygiene and health, and provide efficient protection against the rigors of the climate and the effects of the war. In no case shall permanent places of internment be situated in unhealthy areas or in districts, the climate of which is injurious to the internees. In all cases where the district, in which a protected person is temporarily interned, is an unhealthy area or has a climate which is harmful to his health, he shall be removed to a more suitable place of internment as rapidly as circumstances permit. The premises shall be fully protected from dampness, adequately heated and lighted, in particular between dusk and lights out. The sleeping quarters shall be sufficiently spacious and well ventilated, and the internees shall have suitable bedding and sufficient blankets, account being taken of the climate, and the age, sex, and state of health of the internees. Internees shall have for their use, day and night, sanitary conveniences which conform to the rules of hygiene, and are constantly maintained in a state of cleanliness. They shall be provided with sufficient water and soap for their daily personal toilet and for washing their personal laundry; installations and facilities necessary for this purpose shall be granted to them. Showers or baths shall also be available. The necessary time shall be set aside for washing and for cleaning. Whenever it is necessary, as an exceptional and temporary measure, to accommodate women internees who are not members of a family unit in the same place of internment as men, the provision of separate sleeping quarters and sanitary conveniences for the use of such women internees shall be obligatory."

GC, Article 88 – "In all places of internment exposed to air raids and other hazards of war, shelters adequate in number and structure to ensure the necessary protection shall be installed.

GC, Article 89 – Daily food rations for internees shall be sufficient in quantity, quality and variety to keep internees in a good state of health and prevent the development of nutritional deficiencies. Account shall also be taken of the customary diet of the internees. Internees shall also be given the means by which they can prepare for themselves any additional food in their possession. Sufficient drinking water shall be supplied to internees. ... "

GC Article 91 – "Every place of internment shall have an adequate infirmary, under the direction of a qualified doctor, where internees may have the attention they require, as well as appropriate diet. Isolation wards shall be set aside for cases of contagious or mental diseases. Maternity cases and internees suffering from serious diseases, or whose condition requires special treatment, a surgical operation or hospital care, must be admitted to any institution where adequate treatment can be given and shall receive care not inferior to that provided for the general population. Internees shall, for preference, have the attention of medical personnel of their own nationality. Internees may not be prevented from presenting themselves to the medical authorities for examination. The medical authorities of the Detaining Power shall, upon request, issue to every internee who has undergone treatment an official certificate showing the nature of his illness or injury, and the duration and nature of the treatment given. A duplicate of this certificate shall be forwarded to the Central Agency provided for in Article 140 Treatment, including the provision of any apparatus necessary for the maintenance of internees in good health, particularly dentures and other artificial appliances and spectacles, shall be free of charge to the internee."

Army Regulation 190-8, Enemy Prisoners of War, Retained Personnel, Civilian Internees and Other Detainees, 1 October 1997, Chapter 5, paragraph 5-2, subparagraph a, states that a safety program for civilian internees (CIs) will be established. Chapter 6, paragraph 6-1,

subparagraphs a & b, (1) through (4), states commanders' responsibilities regarding housing, caring for, and safeguarding CIs in facilities. This regulation is a multi-service regulation implementing DOD Directive 2310.1 and incorporates Army Regulation 190-8 and 190-57 and SECNAV Instruction 3461.3, and Air Force Joint Instruction 31-304 and outlines policies, procedures, and responsibilities for treatment of enemy prisoners of war (EPW), retained personnel (RP), civilian internees (CI), and other detainees (OD) and implements international law for all military operations. The specific language in the regulation follows:

"a. Establishment. A safety program for the CI will be established and administered in accordance with the policies prescribed in AR 385-10 and other pertinent safety directives.

"6-1. Internment Facility

a. Location. The theater commander will be responsible for the location of the CI internment facilities within his or her command. The CI retained temporarily in an unhealthy area or where the climate is harmful to their health will be removed to a more suitable place of internment as soon as possible.

b. Quarters. Adequate shelters to ensure protection against air bombardments and other hazards of war will be provided and precautions against fire will be taken at each CI camp and branch camp.

(1) All necessary and possible measures will be taken to ensure that CI shall, from the outset of their internment, be accommodated in buildings or quarters which afford every possible safeguard as regards hygiene and health, and provide efficient protection against the rigors of the climate and the effects of war. In no case shall permanent places of internment be placed in unhealthy areas, or in districts the climate of which is injurious to CI.

(2) The premises shall be fully protected from dampness, adequately heated and lighted, in particular between dusk and lights out. The sleeping quarters shall be sufficiently spacious and well ventilated, and the internees shall have suitable bedding and sufficient blankets, account being taken of the climate, and the age, sex and state of health of the internees.

(3) Internees shall have for their use, day and night, sanitary conveniences which conform to the rules of hygiene and are constantly maintained in a state of cleanliness. They shall be provided with sufficient water and soap for their daily personal hygiene and for washing their personal laundry; installations and facilities necessary for this purpose shall be provided. Showers or baths shall also be available. The necessary time shall be set aside for washing and for cleaning.

(4) CI shall be administered and housed separately from EPW/RP. Except in the case of families, female CI shall be housed in separate quarters and shall be under the direct supervision of women."

Field Manual (FM) 3-19.1, Military Police Operations, 31 January 2002, Chapter 4, paragraph 4-44, describes the capability of a modular internment/resettlement (I/R) Military Police (MP) battalion that is trained and equipped for an I/R mission. The specific language in the field manual follows:

"4-44. Although the CS MP unit initially handles EPWs/CIs, modular MP (I/R) battalions with assigned MP guard companies and supporting MWD teams are equipped and trained to

handle this mission for the long term. A properly configured modular MP (I/R) battalion can support, safeguard, account for, guard, and provide humane treatment for up to 4,000 EPWs/CIs; 8,000 dislocated civilians; or 1,500 US military prisoners."

FM 3-19.40, Military Police Internment/Resettlement Operations, 1 August 2001, Chapter 6, paragraphs 6-2 and 6-3, discuss the considerations of choosing sites for I/R facilities. The specific language in the field manual follows:

"6-2. The MP coordinate the location with engineers, logistical units, higher headquarters, and the HN. The failure to properly consider and correctly evaluate all factors may increase the logistical and personnel efforts required to support operations. If an I/R facility is improperly located, the entire internee population may require movement when resources are scarce. When selecting a site for a facility, consider the following:

- Will the interned population pose a serious threat to logistical operations if the tactical situation becomes critical?
- Is there a threat of guerrilla activity in the area?
- What is the attitude of the local population?
- What classification of internees will be housed at the site?
- What type of terrain surrounds the site, and will it help or hinder escapes?
- What is the distance from the MSR to the source of logistical support?
- What transportation methods are required and available to move internees, supplies, and equipment?

6-3. In addition, consider the—

- METT-TC.
- Proximity to probable target areas.
- Availability of suitable existing facilities (avoids unnecessary construction).
- Presence of swamps, mosquitoes, and other factors (including water drainage) that affect human health.
 - Existence of an adequate, satisfactory source of potable water. The supply should meet the demands for consumption, food sanitation, personal hygiene, and sewage disposal.
 - Availability of electricity. Portable generators can be used as standby and emergency sources of electricity.
 - Distance to work if internees are employed outside the facility.
 - Availability of construction material.
 - Soil drainage."

d. Finding 4:

(1) Finding: Tactical commanders and leaders adapted to the environment and held detainees longer than doctrinally recommended due to the demand for timely, tactical intelligence.

(2) Standard: Army Regulation (AR) 190-8, Enemy Prisoners of War, Retained Personnel, Civilian Internees and Other Detainees, 1 October 1997, Chapter 2, paragraph 2-1, subparagraph a (d), states that prisoners may be interrogated in the combat zone; subparagraph a (e) states that prisoners will be evacuated as quickly as possible from the collecting points (CPs) to the Corps Holding Area (CHA). If evacuation is delayed the detaining

force will increase the level of humanitarian care provided at the CP. Chapter 3, paragraph 3-2, subparagraph b, states that CPs will operate under conditions similar to those prescribed for internment camps; paragraph 3-4, subparagraph e, requires enemy prisoners of war (EPWs) and retained persons (RP) to be housed under the same conditions as U.S. Forces residing in the same area; subparagraph i requires EPW/RP facilities to ensure a clean and healthy environment for detainees. Chapter 6, paragraph 6-1, subparagraph b, requires that internment facilities for CIs provide a safe and sanitary environment; paragraph 6-6, subparagraph g, requires facilities housing Civilian Internees (CI) to provide hygiene and sanitation measures in accordance with AR 40-5, Preventive Medicine. This regulation is a multi-service regulation implementing DOD Directive 2310.1 and incorporates Army Regulation 190-8 and 190-57 and SECNAV Instruction 3461.3, and Air Force Joint Instruction 31-304 and outlines policies, procedures, and responsibilities for treatment of EPW, RP, CI, and other detainees (OD) and implements international law for all military operations. The specific language in the regulation follows:

2-1. a. (d) – "Prisoners may be interrogated in the combat zone.

2-1. a. (e) – "Prisoners will be humanely evacuated from the combat zone and into appropriate channels as quickly as possible. . . . When military necessity requires delay in evacuation beyond a reasonable period of time, health and comfort items will be issued, such as food, potable water, appropriate clothing, shelter, and medical attention.

3-2. b. – ". . . Transit camps or collecting points will operate under conditions similar to those prescribed for permanent prisoner of war camps, and the prisoners will receive the same treatment as in permanent EPW camps.

3-4. e. – "EPW/RP will be quartered under conditions as favorable as those for the force of the detaining power billeted in the same area. The conditions shall make allowance for the habits and customs of the prisoners and shall in no case be prejudicial to their health. The forgoing shall apply in particular to the dormitories of EPW/RP as it regards both total surface and minimum cubic space and the general installation of bedding and blankets. Quarters furnished to EPW/RP must be protected from dampness, must be adequately lit and heated (particularly between dusk and lights-out), and must have adequate precautions taken against the dangers of fire. In camps accommodating both sexes, EPW/RP will be provided with separate facilities for women.

Field Manual (FM) 3-19.40, Military Police Internment/Resettlement Operations, 1 August 2001, Introduction, explains the role of MPs in establishing CPs. Chapter 3, paragraph 3-1, further explains the MP role in establishing CPs and CHAs; paragraph 3-3, states that MPs and MI interrogation teams should work closely at CPs and CHAs to make a determination of the potential intelligence value of detainees; paragraphs 3-37, 3-45 and 3-54, state that divisions will operate forward and central CPs as temporary holding areas until detainees are removed from the battlefield and transferred to the CHA. Doctrine states that detainees should remain at a forward CP no longer than 12 hours, and a central CP no longer than 24 hours. Paragraphs 3-41 to 3-43 identify planning considerations for division forward and central CPs. Doctrine identifies divisions providing minimum medical, preventive medical, logistics, personnel and infrastructure support to hold detainees for 12 hours at forward CPs and for 24 hours at central CPs. Paragraph 3-49 describes the Preventive Medicine (PVNTMED) support to a central CP. Paragraph 3-55 states that CHAs are more permanent than CPs and must be prepared to hold detainees for 72 hours. External support is required if CHAs are required to hold detainees for more than 72 hours. Chapter 5, paragraph 5-52, describes the sanitation

requirements for Civilian Internee (CI) populations. The specific language in the field manual follows:

Introduction – "A large number of captives on the battlefield hampers maneuver units as they move to engage and destroy an enemy. To assist maneuver units in performing their mission—

- Division MP units operate CPs in the division AO.
- Corps MP units operate holding areas in the corps AO."

"3.1. The MP units accept captives from capturing units as far forward as possible, and captives are held in CPs and CHAs until they are removed from the battlefield. Normally, CPs are operated in the division AO and CHAs are operated in the corps AO; but they can be operated anywhere they are needed. The CPs and CHAs sustain and safeguard captives and ensure a minimum level of field processing and accountability. Wounded and sick captives receive medical treatment, and captives who require lifesaving medical attention are evacuated to the nearest medical facility.

3.3. The MP work closely with military intelligence (MI) interrogation teams at CPs and CHAs to determine if captives, their equipment, and their weapons have intelligence value. This process is accelerated when MI interrogation teams can observe captives during arrival and processing, and interrogators can also be used as interpreters during this phase. Before a captive is interviewed by MI personnel, he must have a Department of Defense (DD) Form 2745 (Figure 3-1) attached to him and be accounted for on DD Form 2708.

3-37. A division operates two types of CPs-forward and central. A division MP company operates forward CPs in each maneuver brigade AO and a central CP in the division rear area. Both CPs are temporary areas designed to hold captives until they are removed from the battlefield. Forward CPs are positioned as far forward as possible to accept captives from maneuver elements. Central CPs accept captives from forward CPs and local units.

3-41. Medical support is provided by the MP company medical section. Additional medical support can be requested through the forward support battalion (FSB) to the brigade medical officer. The brigade OPORD includes specific actions and support (operational requirements) needed from non-MP units.

3-42. When a division MP company commander is tasked with planning and operating a forward CP, he-

- Coordinates with the unit responsible for the area.
- Conducts a recon of the area before selecting a location.
- Locates it far enough from the fighting to avoid minor shifts in the main battle area (MBA) (normally 5 to 10 kilometers).
- Notifies the BSA tactical operations center (TOC) and the PM operations section of the selected location (grid coordinates). The BSA TOC reports the location to the brigade TOC, and the brigade TOC notifies subordinate units.
- Coordinates with MI on co-locating an MI interrogation team at the CP.
- Provides potable water and, if required, food for captives.

3-43. A forward CP is seldom located near the indigenous population to prevent problems caused by the presence of captives in the area. A forward CP is usually a guarded,

roped-off area (concertina or razor tape) or a secure, fixed facility. The capture rate and the captive categories determine the size of forward CP.

3-45. Captives should not remain at a forward CP more than 12 hours before being escorted to the central CP.

3-49. The division PVNTMED section supports the central CP by—

- Monitoring drinking water and advising on disinfection procedures.
- Controlling animals and insects that carry disease.
- Ensuring that captives help prevent illness by—
 - Drinking enough water.
 - Wearing clothing that is suited for the weather and the situation.
 - Handling heating fuels carefully.
 - Avoiding contact of exposed skin to cold metal.
 - Using insect repellent, netting, and insecticides.
 - Taking approved preventive medication.
 - Using purification tablets when water quality is uncertain.
 - Disposing of bodily wastes properly.
 - Practicing personal hygiene.

3-54. Captives should not remain at the central CP more than 24 hours before being evacuated to the CHA.

3-55. A CHA (Figure 3-4) can hold more captives for longer periods of times than a central CP. Depending on the availability of MP units to establish I/R facilities, corps MP units must be prepared to hold captives at the CHA more than 72 hours. If the CHA keeps captives more than 72 hours, MP must plan and coordinate for the increased logistics and personnel required to operate a long-term facility. The decision to hold captives longer is based on METT-TC and the availability of forces. Captives remain in the CHA until they are evacuated to an I/R facility or until hostilities end."

e. Finding 5:

(1) Finding: Doctrine does not clearly specify the interdependent, and yet independent, roles, missions, and responsibilities of Military Police and Military Intelligence units in the establishment and operation of interrogation facilities.

(2) Standard: Department of Defense Directive (DoDD) 2310.1, DoD Program for Enemy Prisoners of War (EPOW) and Other Detainees, 18 August 1994, Paragraph 3.4, outlines the disposition of persons captured or detained and indicates who should operate collecting points, other holding facilities and installations. The specific language in the directive follows:

"Persons captured or detained by the U.S. Military Services shall normally be handed over for safeguarding to U.S. Army Military Police, or to detainee collecting points or other holding facilities and installations operated by U.S. Army Military Police as soon as practical. Detainees may be interviewed for intelligence collection purposes at facilities and installations operated by U.S. Army Military Police."

Joint Publication (JP) 1-02, Department of Defense Dictionary of Military and Associated Terms, 12 April 2001 (as amended through 23 March 2004), defines "tactical control", often abbreviated by the acronym "TACON". The specific language in the joint publication follows:

"tactical control — Command authority over assigned or attached forces or commands, or military capability or forces made available for tasking, that is limited to the detailed direction and control of movements or maneuvers within the operational area necessary to accomplish missions or tasks assigned. Tactical control is inherent in operational control. Tactical control may be delegated to, and exercised at any level at or below the level of combatant command. When forces are transferred between combatant commands, the command relationship the gaining commander will exercise (and the losing commander will relinquish) over these forces must be specified by the Secretary of Defense. Tactical control provides sufficient authority for controlling and directing the application of force or tactical use of combat support assets within the assigned mission or task. Also called TACON."

JP 2-01, Joint Intelligence Support to Military Operations, 20 November 1996, Appendix G, paragraph 1, subparagraph d, describes the organization and function of the Joint Interrogation and Debriefing Center (JIDC). The specific language in the joint publication follows:

"Joint Interrogation and Debriefing Center. The JFC normally tasks the Army component commander to establish, secure, and maintain an EPW camp system. Under some circumstances, particularly during MOOTW, the JFC may designate another component commander to be responsible for the EPW camp system. The subordinate joint force J-2 establishes a JIDC for follow-on exploitation. The establishment (when, where, and how) of the JIDC is highly situation dependent, with the main factors being the geographic nature of the JOA, the type and pace of military operations, the camp structure, and the number and type of the sources. The JIDC may be a central site where appropriate EPW are segregated for interrogation, or it may be more of a clearinghouse operation for dispatch of interrogators or debriefers to other locations.

- Organization. The JIDC interrogation and debriefing activities are managed by the subordinate joint force HUMINT staff section or HOC. The HOC will coordinate with the TFCICA within the J-2X for CI [counterintelligence] augmentation for exploitation of those personnel of CI [counterintelligence] interest, such as civil and/or military leadership, intelligence or political officers and terrorists. The staff is augmented by deployed DHS personnel, linguists and, as required, component personnel. The HUMINT appendix of Annex B (Intelligence) to the OPLAN or CONPLAN contains JIDC planning considerations.

- Responsibilities. Service component interrogators collect tactical intelligence from EPWs based on joint force J-2 criteria. EPWs (i.e., senior level EPWs) are screened by the components and those of further intelligence potential are identified and processed for follow-on interrogation and debriefing by the JIDC to satisfy theater strategic and operational requirements. In addition to EPW, the JIDC may also interrogate civilian detainees, and debrief refugees as well as other non-prisoner sources for operational and strategic information."

FM 3-31, Joint Force Land Component Commander Handbook (JFLCC), 13 December 2001, Appendix A, paragraph A-11, describes the roles of the Joint Interrogation Facility (JIF) and the Joint Interrogation and Debriefing Center (JIDC). The specific language in the field manual follows:

"The following may be established or requested by the JFLCC in addition to the J-2X [J-2 CI [counterintelligence] and HUMINT Support Element] and JACE [Joint Analysis and Control Element]:

Joint Interrogation Facility (JIF). JIF conducts initial screening and interrogation of EPWs, translation and exploitation of captured adversary documents, and debriefing of captured or detained US personnel released or escaped from adversary control. It coordinates exploitation of captured equipment with the JCMEC [Joint Captured Materiel Exploitation Center], documents with the JDEC [Joint Document Exploitation Center], and human sources with the JIDC [Joint Interrogation and Debriefing Center]. More than one JIF may be established in the JOA depending upon the anticipated number of EPWs.

JIDC. JIDC conducts follow-on exploitation of EPWs. EPWs are screened by the JIFs, and those of further intelligence potential are identified and forwarded to the JIDC for follow-on interrogation and debriefing in support of JTF and higher requirements. Besides EPWs, the JIDC may also interrogate civilian detainees, refugees, and other nonprisoner sources. JIDC activities are managed by the J-2X HOC [HUMINT Operations Cell]."

FM 34-52, Intelligence Interrogation, 28 September 1992, Preface, establishes this FM as the doctrinal foundation for interrogations of detainees. Chapter 1 defines and explains the purpose of interrogation. Chapter 2 describes the organization and operation of the Theater Interrogation Facility (TIF). The specific language in the field manual follows:

Preface – "This manual provides doctrinal guidance, techniques, and procedures governing employment of interrogators as human intelligence (HUMINT) collection assets in support of the commander's intelligence needs. It outlines the interrogator's role within the intelligence collection effort and the supported unit's day-to-day operations.

This manual is intended for use by interrogators as well as commanders, staff officers, and military intelligence (MI) personnel charged with the responsibility of the interrogation collection effort."

Chapter 1 – "Interrogation is the process of questioning a source to obtain the maximum amount of usable information. The goal of any interrogation is to obtain reliable information in a lawful manner, in a minimum amount of time, and to satisfy intelligence requirements of any echelon of command.

A good interrogation produces needed information, which is timely, complete, clear, and accurate."

Chapter 2 – "At echelons above corps (EAC), the MI company (I&E), MI battalion (C&E) or (I&E), MI brigade (EAC), will form the Theater Interrogation Facility (TIF). The TIF, which is commanded by an MI captain, provides interrogation support to the theater or joint command and to national level intelligence agencies. The TIF will—

- Be located within the main theater EPW internment facility.
- Be tailored organizationally to meet requirements of the theater and situation.
- Include interrogators, CI [counterintelligence] personnel, and intelligence analysts from the Army, Air Force, Marine Corps, and, in some cases, the Navy.
- Be organized similarly to the CIF; that is, by function.

- Have intelligence analysts to handle requirements and keep interrogators informed of changes in the operational or strategic situation.
- Maintain the capability to deploy "GO" teams to multiple theater EPW camps, as well as to forward deploy them to corps and ECB as needed.
- Provide experienced senior interrogation warrant officers and NCOs who are graduates of the Department of Defense (DOD) Strategic Debriefing Course (additional skill identifier 9N or N7) and physical plant for the Joint Debriefing Center (JDC), where exploitation of high-level (Category A) sources takes place on operational and strategic topics."

"THEATER INTERROGATION FACILITY

The EAC interrogation facility will normally be designated as the TIF. A TIF is staffed by US Army interrogators and analysts, with support from Air Force, Navy, Marine Corps, and other US national agencies as required. In a multinational operation, a combined interrogation facility may be established with allied interrogator augmentation. In addition to conventional theater Army operations, a TIF may be established to support a joint or unified command to meet theater requirements during crisis or contingency deployments.

MI battalion companies, MI brigade (EAC) provide US Army interrogation support to the EAC TIF. The mission of the TIF is to—

- Establish liaison with host nation (HN) commanders to achieve critical intelligence information in response to theater and national level intelligence collection requirements.
- Ensure communication between HN and US military TF commanders, and establish rapport with HN interrogation activities.
- Coordinate for national level collection requirements.
- Interrogate PWs, high-level political and military personnel, civilian internees, defectors, refugees, and displaced persons.
- Participate in debriefings of US and allied personnel who have escaped after being captured, or who have evaded capture.
- Translate and exploit selected CEDs.
- Assist in technical support activity (TSA) operations (see FM 34-5(S)).

The MI battalion (I&E) has an HHC for C³, and three interrogation companies, of which one is Active Component (AC) and the other two are RC. The companies consist of two MI companies, I&E (EPW support) and one MI company, I&E (GS-EAC).

The two MI companies support EPW compound operations. Their elements are primarily for GS at EAC, but may be deployed for DS at corps and division. The MI company (I&E) (GS-EAC) provides priority interrogation and DOCEX support to corps and divisions, to the TIF, and to temporary EPW compounds as required.

A TIF is organized into a headquarters section, operations section, and two interrogation and DOCEX sections. It will normally have an attached TSA section from Operations Group, and a liaison team from the Joint Captured Materiel Exploitation Center (JCMEC). The JCMEC liaison team assists in exploiting sources who have knowledge of captured enemy weapons and equipment.

The headquarters section provides all command, administrative, logistical, and maintenance support to the TIF. It coordinates with—

- Commander, MI Battalion (I&E) for personnel status, administrative support, and logistical support prior to deployment.
- Battalion S3 for deployment of interrogation assets.
- Theater J2 for reporting procedures, operational situation update, and theater and national level intelligence requirements.
- Provost marshal for location of theater EPW camps, and for procedures to be followed by interrogators and MP for processing, interrogating, and internment.
- Commanders of theater medical support units and internment facility for procedures to treat, and clear for questioning, wounded EPWs.
- Commander, CI [counterintelligence] company, for CI [counterintelligence] requirements and joint interrogation and CI [counterintelligence] procedures.

OPERATIONS SECTION

This section (where ideally the officer in charge [OIC] has the 3Q additional skill identifier) is organized into the operations, OB, and communications elements. The operations section—

- Designates work areas for all TIF elements.
- Establishes and maintains TIF functional files.
- Establishes interrogation priorities.
- Maintains a daily log and journal.
- Disseminates incoming and outgoing distribution.
- Conducts liaison with local officials, adjacent and subordinate intelligence activities, CI [counterintelligence], MP, PSYOP, the JCMEC, Plans and Policy Directorate (J5), and provost marshal.
- Conducts coordination with holding area OIC or enclosure commander for screening site, medical support, access, movement, and evacuation procedures for EPWs.
- Conducts operations briefings when required.

- Manages screening operations.
- Manages EPW access for intelligence collection.
- Assigns control numbers (see DIAM 58-13).
- Supervises all intelligence collection activities within the TIF."

Army Regulation (AR) 190-8, Enemy Prisoners of War, Retained Personnel, Civilian Internees and Other Detainees, 1 October 1997, Chapter 2, paragraph 2-1, provides the regulatory guidance for interrogation of detainees in a combat zone. This regulation is a multi-service regulation implementing DOD Directive 2310.1 and incorporates Army Regulation 190-8 and 190-57 and SECNAV Instruction 3461.3, and Air Force Joint Instruction 31-304 and outlines policies, procedures, and responsibilities for treatment of enemy prisoners of war (EPW), retained personnel (RP), civilian internees (CI), and other detainees (OD) and implements international law for all military operations. The specific language in the regulation follows:

"(d) Prisoners may be interrogated in the combat zone. The use of physical or mental torture or any coercion to compel prisoners to provide information is prohibited. Prisoners may voluntarily cooperate with PSYOP personnel in the development, evaluation, or dissemination of PSYOP messages or products. Prisoners may not be threatened, insulted, or exposed to unpleasant or disparate treatment of any kind because of their refusal to answer questions. Interrogations will normally be performed by intelligence or counterintelligence personnel."

Field Manual (FM) 3-19.1, Military Police Operations, 31 January 2002, Chapter 4, paragraphs 4-42 and 4-43, describe the role of MP units in detainee operations and references MI. The specific language in the field manual follows:

"4-42. The Army is the Department of Defense's (DoD's) executive agent for all EPW/CI operations. Additionally, the Army is DoD's executive agent for long-term confinement of US military prisoners. Within the Army and through the combatant commander, the MP is tasked with coordinating shelter, protection, accountability, and sustainment for EPWs/CIs. The I/R function addresses MP roles when dealing with EPWs/CIs, dislocated civilians, and US military prisoners.

4-43. The I/R function is of humane as well as tactical importance. In any conflict involving US forces, safe and humane treatment of EPWs/CIs is required by international law. Military actions on the modern battlefield will result in many EPWs/CIs. Entire units of enemy forces, separated and disorganized by the shock of intensive combat, may be captured. This can place a tremendous challenge on tactical forces and can significantly reduce the capturing unit's combat effectiveness. The MP supports the battlefield commander by relieving him of the problem of handling EPWs/CIs with combat forces. The MP performs their I/R function of collecting, evacuating, and securing EPWs throughout the AO. In this process, the MP coordinates with MI to collect information that may be used in current or future operations."

FM 3-19.40, Military Police Internment/Resettlement Operations, 1 August 2001, Preface, establishes this FM as the doctrinal foundation for detainee operations. Chapter 2, paragraph 2-1, describes the role of the MP Battalion Commander. Chapter 3, paragraph 3-3, states the need for MP and MI to work closely, and paragraphs 3-64 to 3-66 describe the MP-MI

interaction at collecting points (CPs) and corps holding areas (CHAs). The specific language in the field manual follows:

"Field Manual (FM) 3-19.40 depicts the doctrinal foundation, principles, and processes that MP will employ when dealing with enemy prisoners of war (EPWs), civilian internees (CIs), US military prisoner operations, and MP support to civil-military operations (populace and resource control [PRC], humanitarian assistance [HA], and emergency services [ES]).

2-1. An MP battalion commander tasked with operating an I/R facility is also the facility commander. As such, he is responsible for the safety and well-being of all personnel housed within the facility. Since an MP unit may be tasked to handle different categories of personnel (EPW, CI, OD, refugee, and US military prisoner), the commander, the cadre, and support personnel must be aware of the requirements for each category.

3-3. The MP work closely with military intelligence (MI) interrogation teams at CPs and CHAs to determine if captives, their equipment, and their weapons have intelligence value.

3-64. To facilitate collecting enemy tactical information, MI may collocate interrogation teams at CPs and CHAs. This provides MI with direct access to captives and their equipment and documents. Coordination is made between MP and MI to establish operating procedures that include accountability. An interrogation area is established away from the receiving/processing line so that MI personnel can interrogate captives and examine their equipment and documents. If a captive or his equipment or documents are removed from the receiving/processing line, account for them on DD Form 2708 and DA Form 4137.

3-65. The MI interrogation teams screen captives at CPs and CHAs, looking for anyone who is a potential source of information. Screeners observe captives from an area close to the dismount point or processing area. As each captive passes, MI personnel examine the capture tag and look for branch insignias that indicate a captive with information to support command priority intelligence requirements (PIR) and information requirements (IR). They also look for captives who are willing or attempting to talk to guards; joining the wrong group intentionally; or displaying signs of nervousness, anxiety, or fear.

3-66. The MP assist MI screeners by identifying captives who may have answers that support PIR and IR. Because MP are in constant contact with captives, they see how certain captives respond to orders and see the type of requests they make. The MP ensure that searches requested by MI are conducted out of sight of other captives and that guards conduct same-gender searches."

FM 6-0, Mission Command: Command and Control of Army Forces, 11 August 2003, Appendix D, paragraph D-114, describes the responsibilities of the Provost Marshal (PM). The specific language in the field manual follows:

"PM responsibilities include—

- Internment and resettlement of EPWs and civilian internees, dislocated civilians, and US military prisoners, including their—
 - Collection.
 - Detention and internment.
 - Protection.
 - Sustainment.

- Evacuation.

- Coordinating for all logistic requirements relative to EPW and civilian internees, US military prisoners, and dislocated civilians (with the G-4).
- Coordinating on EPW and civilian internee pay support, and financial aspects of weapons bounty programs (with the finance officer and RM)."

FM 34-52, Intelligence Interrogation, 28 September 1992, Preface, establishes this FM as the doctrinal foundation for interrogations of detainees. Chapter 1 defines and explains the purpose of interrogation. Chapter 2 describes the role of MPs in the operation of CPs and CHAs. Chapter 3 describes the role of MPs in the MI screening process. Chapter 4 allows MI to assume control of detainees from MP for interrogation. The specific language in the field manual follows:

Preface – "This manual provides doctrinal guidance, techniques, and procedures governing employment of interrogators as human intelligence (HUMINT) collection assets in support of the commander's intelligence needs. It outlines the interrogator's role within the intelligence collection effort and the supported unit's day-to-day operations.

This manual is intended for use by interrogators as well as commanders, staff officers, and military intelligence (MI) personnel charged with the responsibility of the interrogation collection effort."

"Chapter 1 – Interrogation is the process of questioning a source to obtain the maximum amount of usable information. The goal of any interrogation is to obtain reliable information in a lawful manner, in a minimum amount of time, and to satisfy intelligence requirements of any echelon of command.

A good interrogation produces needed information, which is timely, complete, clear, and accurate."

"Chapter 2 – The division's central EPW collecting point is operated by division MP under the supervision of the division provost marshal.

The capturing unit escorts or transports EPWs or detainees to the nearest collecting point, and turns them over to the MP. Interrogators in DS of the brigade will screen and categorize all EPWs or detainees, question them, and report information obtained in response to brigade PIR, IR, and SIR.

The corps MP commander operates the corps EPW holding area and provides escort guard support to divisions for EPW evacuation in routine or medical channels.

"Chapter 3 – Screeners coordinate with MP holding area guards on their role in the screening process. The guards are told where the screening will take place, how EPWs and detainees are to be brought there from the holding area, and what types of behavior on their part will facilitate the screenings."

"Chapter 4 – MI assumes control from the MP when interrogators determine a captured item or EPW is of intelligence value."

f. Finding 6:

(1) **Finding:** Military Intelligence units are not resourced with sufficient interrogators and interpreters, to conduct timely detainee screenings and interrogations in the current operating environment, resulting in a backlog of interrogations and the potential loss of intelligence.

(2) **Standard:** Army Regulation (AR) 190-8, Enemy Prisoners of War, Retained Personnel, Civilian Internees and Other Detainees, 1 October 1997, Chapter 2, paragraph 2-1, provides the regulatory guidance for interrogation of detainees in a combat zone. This regulation is a multi-service regulation implementing DOD Directive 2310.1 and incorporates Army Regulation 190-8 and 190-57 and SECNAV Instruction 3461.3, and Air Force Joint Instruction 31-304 and outlines policies, procedures, and responsibilities for treatment of enemy prisoners of war (EPW), retained personnel (RP), civilian internees (CI), and other detainees (OD) and implements international law for all military operations. The specific language in the regulation follows:

"(d) Prisoners may be interrogated in the combat zone. The use of physical or mental torture or any coercion to compel prisoners to provide information is prohibited. Prisoners may voluntarily cooperate with PSYOP personnel in the development, evaluation, or dissemination of PSYOP messages or products. Prisoners may not be threatened, insulted, or exposed to unpleasant or disparate treatment of any kind because of their refusal to answer questions. Interrogations will normally be performed by intelligence or counterintelligence personnel."

Field Manual (FM) 3-19.40, Military Police Internment/Resettlement Operations, 1 August 2001, Chapters 2 and 3, paragraphs 2-48, 3-3, 3-13, 3-65 to 3-68, describe doctrine for Military Intelligence (MI) operations in internment/resettlement (I/R) facilities. The specific language in the field manual follows:

"2-48. Personnel assigned or attached to I/R facilities are trained on the care and control of housed personnel. They are fully cognizant of the provisions of the Geneva and UN Conventions and applicable regulations as they apply to the treatment of housed personnel. A formal training program should include—

- Principles and laws of land warfare, specifically provisions of Geneva and UN Conventions and HN laws and customs.
- Supervisory and human relations techniques.
- Methods of self-defense.
- The use of force, the ROE, and the ROI.
- Firearms qualification and familiarization.
- Public relations, particularly CONUS operations.
- First aid.
- Stress management techniques.
- Facility regulations and SOPs.
- Intelligence and counterintelligence techniques.
- Cultural customs and habits of internees."

"3-3. The MP work closely with military intelligence (MI) interrogation teams at CPs and CHAs to determine if captives, their equipment, and their weapons have intelligence value. This process is accelerated when MI interrogation teams can observe captives during arrival and processing, and interrogators can also be used as interpreters during this phase. Before a

captive is interviewed by MI personnel, he must have a Department of Defense (DD) Form 2745 (Figure 3-1) attached to him and be accounted for on DD Form 2708.

3-13. The MP coordinate with MI interrogation teams to determine which confiscated items have intelligence value. Personal items (diaries, letters from home, and family pictures) can be taken by MI teams for review and then returned to the proper owner via MP."

"INTERROGATION TEAMS

"3-65. The MI interrogation teams screen captives at CPs and CHAs, looking for anyone who is a potential source of information. Screeners observe captives from an area close to the dismount point or processing area. As each captive passes, MI personnel examine the capture tag and look for branch insignias that indicate a captive with information to support command priority intelligence requirements (PIR) and information requirements (IR). They also look for captives who are willing or attempting to talk to guards; joining the wrong group intentionally; or displaying signs of nervousness, anxiety, or fear.

3-66. The MP assist MI screeners by identifying captives who may have answers that support PIR and IR. Because MP are in constant contact with captives, they see how certain captives respond to orders and see the type of requests they make. The MP ensure that searches requested by MI are conducted out of sight of other captives and that guards conduct same-gender searches.

3-67. The MI screeners examine captured documents, equipment and, in some cases, personal papers (journals, diaries, and letters from home). They are looking for information that identifies a captive and his organization, mission, and personal background (family, knowledge, and experience). Knowledge of a captive's physical and emotional status or other information helps screeners determine his willingness to cooperate.

LOCATION

3-68. Consider the following when planning an MI screening site:

- The site is located where screeners can observe captives as they are segregated and processed. It is shielded from the direct view of captives and is far enough away that captives cannot overhear screeners' conversations.
- The site has an operation, administrative, and interrogation area. The interrogation area accommodates an interrogator, a captive, a guard, and an interpreter as well as furniture. Lights are available for night operations.
- Procedures are implemented to verify that sick and wounded captives have been treated and released by authorized medical personnel.
- Guards are available and procedures are implemented for escorting captives to the interrogation site.
- Procedures are published to inform screeners who will be moved and when they will be moved.
- Accountability procedures are implemented and required forms are available."

FM 3-31, Joint Force Land Component Commander Handbook (JFLCC), 13 December 2001, Appendix A, paragraph A-11, describes the role of the Joint Interrogation and Debriefing Center (JIDC). The specific language in the field manual follows:

"JIDC conducts follow-on exploitation of EPWs. EPWs are screened by the JIFs, and those of further intelligence potential are identified and forwarded to the JIDC for follow-on interrogation and debriefing in support of JTF and higher requirements. Besides EPWs, the JIDC may also interrogate civilian detainees, refugees, and other nonprisoner sources. JIDC activities are managed by the J-2X HOC."

FM 27-10, The Law of Land Warfare, 18 July 1956 (change 1, 15 July 1976), Paragraph 93, describes guidelines for the questioning of enemy prisoners of war (EPWs). The specific language in the field manual follows:

"Every prisoner of war, when questioned on the subject, is bound to give only his surname, first names and rank, date of birth, and army, regimental, personal or serial number, or failing this equivalent information. If he willfully infringes this rule, he may render himself liable to a restriction of the privileges accorded to his rank or status. Each Party to a conflict is required to furnish the persons under its jurisdiction who are liable to become prisoners of war, with an identity card showing the owner's surname, first names, rank, army, regimental, personal or serial number or equivalent information, and date of birth. The identity card may, furthermore, bear the signature or the fingerprints, or both, of the owner, and may bear, as well, any other information the Party to the conflict may wish to add concerning persons belonging to its armed forces. As far as possible the card shall measure 6.5 x 10 cm. and shall be issued in duplicate. The identity card shall be shown by the prisoner of war upon demand, but may in no case be taken away from him. No physical or mental torture, nor any other form of coercion, may be inflicted on prisoners of war to secure from them information of any kind whatever. Prisoners of war who refuse to answer may not be threatened, insulted, or exposed to unpleasant or disadvantageous treatment of any kind."

FM 34-52, Intelligence Interrogation, 28 September 1992, Chapter 1, defines and explains the purpose of interrogation. The specific language in the field manual follows:

"Interrogation is the process of questioning a source to obtain the maximum amount of usable information. The goal of any interrogation is to obtain reliable information in a lawful manner, in a minimum amount of time, and to satisfy intelligence requirements of any echelon of command.

A good interrogation produces needed information, which is timely, complete, clear, and accurate."

Special Text (ST) 2-22.7 (FM 34-7-1), Tactical Human Intelligence and Counterintelligence Operations, 11 April 2002, Chapter 1, paragraphs 1-19, 1-21 to 1-25, provides the doctrinal basis for the structure and utilization of tactical human intelligence assets. The specific language in the special text follows:

"1-19. The requirement for collectors is based on the density of the potential source pool. The basic methodology of collection does not change in the urban environment; however, the density of the population results in a proportional increase in the number of collectors required. This need for additional assets has been illustrated by recent operations in Somalia, Haiti, Bosnia, and Kosovo."

"ARMY CORPS AND BELOW

1-21. Army HUMINT and CI assets organic at corps and below are uniquely qualified to be the primary collection asset in many of our future conflicts. They are organic to—

- Tactical exploitation battalions (TEBs) and the corps support battalions (CSBs) at the Corps MI brigade.
- MI battalions at division.
- MI companies at armored cavalry regiments (ACRs) and separate brigades (SEP BDEs).
- MI elements at Special Forces Groups (SFGs).

1-22. Army HUMINT and CI assets provide technologically enhanced exploitation of human sources and media. This exploitation provides valuable intelligence to meet the critical requirements affecting the MDMP. The simultaneous digital interaction between operational HUMINT and CI teams and analytical elements provides the deployed commander with near-instantaneous information. This rapid transmission of critical intelligence to the user gives the supported command an information edge and a more complete vision of the battlespace.

INTERIM BRIGADE COMBAT TEAM

1-23. The brigade's intelligence system is a flexible force of Intelligence, Surveillance, and Reconnaissance (ISR) personnel, organizations, and equipment. Individually and collectively, these assets provide commanders throughout the brigade with the capability to plan and direct ISR operations, collect and process information, produce relevant intelligence, and disseminate combat information and intelligence to those who need it, when they need it. The brigade and its subordinate units possess organic ISR assets that enable the above actions. Based on METT-TC considerations the brigade task organizes its organic ISR assets for the operation and, in addition, may receive additional ISR assets from corps, joint, and national organizations.

1-24. The brigade's tactical HUMINT assets include an S2X team, a tactical HUMINT platoon with two operational management teams (OMTs) and tactical HUMINT teams, and troop HUMINT collectors in the reconnaissance, surveillance, and target acquisition (RSTA) squadron. The functions and responsibilities of these assets are the same as at higher echelons. The mission of the Troop HUMINT collector is limited to providing tactical questioning and DOCEX in support of the squadron's multidimensional reconnaissance and surveillance (R&S) mission and identifying possible sources of interest for the tactical HUMINT platoon. The functions of the different teams and offices in tactical HUMINT are similar through the echelons where tactical HUMINT is conducted.

RESERVE COMPONENT INTEGRATION

1-25. Given the Army's current operational tempo and force structure, the integration of RC forces into the AC is a near certainty for future operational deployments. Commanders must identify their requirements early and establish proactive coordination (both in garrison and while deployed) with their RC counterparts to fully integrate them during all phases of training and operations."

ST 2-91.6 Small Unit Support to Intelligence, March 2004, Chapter 2, paragraphs 2-13 to 2-17, explains the use of interpreters in tactical interrogations. The specific language in the special text follows:

"2-13. The use of interpreters is an integral part of the information collection effort. Use of an interpreter is time consuming and potentially confusing. Proper use and control of an interpreter is a skill that must be learned and practiced to maximize the potential of collection.

2-14. Perhaps the most important guideline to remember is that an interpreter is essentially your mouthpiece; he says what you say, but in a different language. This sounds simple, but for those who have never worked with interpreters, problems can quickly develop.

2-15. Upon meeting your interpreter, it is important that you assess his proficiency in English. You need an interpreter with a firm grasp of English and the terminology you may encounter.

2-16. Interpreters are categorized as to capability and clearance they have been granted. The categories below are more fully detailed in Interpreter Ops, Multi-Service Reference Manual for Interpreter Operations, February 2004. This manual can be obtained from the Air Land Sea Application (ALSA) Center.

CATEGORIES OF INTERPRETERS

- CAT I Linguists - Locally hired personnel with an understanding of the English language. These personnel are screened and hired in-theater and do not possess a security clearance. During most operations, CAT I linguists are required to be re-screened by CI personnel on a scheduled basis. CAT I linguists should not be used for HUMINT collection operations.
- CAT II Linguists - CAT II linguists are United States citizens who have native command of the target language and near-native command of the English language. These personnel undergo a screening process, which includes a background check. Upon favorable findings, these personnel are granted an equivalent of a Secret Collateral clearance.
- CAT III Linguists - CAT III linguists are United States citizens who have native command of the target language and native command of the English language. These personnel undergo a screening process, which includes a special background check. Upon favorable findings, these personnel are granted an equivalent of a Top Secret (TS) clearance. CAT III linguists are used mostly for high-ranking official meetings and by strategic collectors.

2-17. The following are several tips that should prove useful when working with an interpreter.

Placement

- When standing, the interpreter should stand just behind you and to the side.
- When sitting, the interpreter should sit right beside you but not between you and the individual.

Body Language and Tone

- Have the interpreter translate your message in the tone you are speaking.

- Ensure the interpreter avoids making gestures.

Delivery

- Talk directly to the person with whom you are speaking, not the interpreter.
- Speak as you would in a normal conversation, not in the third person. For example, do not say, "Tell him that...." Rather say, "I understand that you..." and instruct the interpreter to translate as such.
 - Speak clearly, avoid acronyms or slang, and break sentences uniformly to facilitate translation.
 - Some interpreters will begin to translate while you are still speaking. This is frustrating for some people. If so, discuss the preference of translation with the interpreter.
 - The most important principle to obey while using an interpreter is to remember that you control the conversation, not the interpreter.

Security

- Work on the premise that the interpreter is being debriefed by a threat intelligence service.
 - Always assume the worst.
 - Avoid careless talk.
 - Avoid giving away personal details.
 - Do not become emotionally involved!

Interpreter Checklist for Patrolling

- Tell the interpreter what you expect of him, and how you want him to do it.
- Tell the interpreter exactly what you want translated. The interpreter should translate all conversation between you and the individual without adding anything on his own.
 - Just as questioning should be conducted in such a way as to disguise the true intent of the questioning from the source, you should not reveal intelligence requirements (FFIR, IR, or essential elements of friendly information [EEFI]) to the interpreter. Brief the interpreter on actions to take at the halt or in the event of enemy contact."

g. Finding 7:

(1) **Finding:** Tactical Military Intelligence officers are not adequately trained on how to manage the full spectrum of the collection and analysis of human intelligence.

(2) **Standard:** Army Regulation 350-1, Army Training and Education, 9 April 2003, Chapter 3, paragraph 3-2, requires that TRADOC establish training and education goals and objectives for all Army personnel. The specific language in the regulation follows:

"Training proponents. These would include TRADOC schools and colleges, USAJFKSWC&S and AMEDDC&S and would perform the following.

(a) Develop courses based on established training and education goals and objectives as well as the duties, responsibilities, and missions their graduates will be assigned.

(b) Develop, evaluate, and train leader, technical, and tactical tasks that focus on missions for the size or type units to which graduates will be assigned.

(c) Provide progressive and sequential training.

(d) Provide personnel serving at the same organizational level with training consisting of the same tasks, conditions, and standards.

(e) Provide leader, technical, and tactical training that affords soldiers and DA civilians an opportunity to acquire the skills and knowledge needed to perform more complex duties and missions of greater responsibility."

Field Manual (FM) 7-0, Training the Force, 22 October 2002, Chapter 1, paragraph 1-29, gives overall guidance for the implementation of Professional Military Education (PME). The specific language in the field manual follows:

"Professional Military Education - PME develops Army leaders. Officer, warrant officer, and NCO training and education is a continuous, career-long, learning process that integrates structured programs of instruction—resident at the institution and non-resident via distributed learning at home station. PME is progressive and sequential, provides a doctrinal foundation, and builds on previous training, education and operational experiences. PME provides hands-on technical, tactical, and leader training focused to ensure leaders are prepared for success in their next assignment and higher-level responsibility.

- Officer Education System (OES). Army officers must lead and fight; be tactically and technically competent; possess leader skills; understand how the Army operates as a service, as well as a component of a joint, multinational, or interagency organization; demonstrate confidence, integrity, critical judgment, and responsibility; operate in a complex, uncertain, and rapidly changing environment; build effective teams amid continuous organizational and technological change; and solve problems creatively. OES develops officers who are self-aware and adaptive to lead Army units to mission success.

- Warrant Officer Education System (WOES). Warrant officers are the Army's technical experts. WOES develops a corps of highly specialized experts and trainers who are fully competent and proficient operators, maintainers, administrators, and managers of the Army's equipment, support activities, and technical systems.

- NCO Education System (NCOES). NCOES trains NCOs to lead and train soldiers, crews, and subordinate leaders who work and fight under their leadership. NCOES provides hands-on technical, tactical, and leader training focused to ensure that NCOs are prepared for success in their next assignment and higher-level responsibility.

- Functional Training. In addition to the preceding PME courses, there are functional courses available in both resident and non-resident distributed learning modes that enhance functional skills for specific duty positions. Examples are Battalion S2, Battalion Motor Officer, First Sergeant, Battle Staff NCO, and Airborne courses."

FM 34-52, Intelligence Interrogation, 28 September 1992, Chapter 1, Intelligence Disciplines, states that the Intelligence Electronic Warfare (IEW) system includes three MI disciplines. The specific language in the field manual follows:

"HUMINT -

HUMINT is obtained from information collected from human sources and consists of the following intelligence collection operations. Interrogation of EPWs, civilian detainees, insurgents, defectors, refugees, displaced persons and agents and suspected agents.

- Long-range surveillance patrols.
- Strategic debriefing
- Controlled collection operations
- Open-source exploitation, to include publications and broadcasts.
- Reports of contact from forward units.
- Observation and listening posts
- Low-level source operations (LLSO)
- HUMINT liaison contacts

HUMINT is vital in all combat operations, regardless of echelon or intensity of conflict. By nature, HUMINT lends itself to the collection of information about the enemy's thought processes and intentions. HUMINT can provide information on almost any topic of intelligence interest, including order of battle (OB) factors, as well as scientific and technical (S&T) intelligence subjects. During operation Desert Storm, interrogators collected information which helped to -

- Develop a plan to breach Iraqi defensive belts.
- Confirm Iraqi supply line interdiction by coalition air strikes.
- Identify diminishing Iraqi troop morale.
- Identify a US Prisoner of war captured during the battle of Kanji."

h. **Finding 8:**

(1) **Finding:** The DAIG Team found that officially approved CJTF-7 and CJTF-180 policies and the early CJTF-180 practices generally met legal obligations under US law, treaty obligations and policy, if executed carefully, by trained soldiers, under the full range of safeguards. The DAIG Team found that policy was not clear and contained ambiguity. The DAIG Team found implementation, training, and oversight of these policies was inconsistent; the Team concluded, however, based on a review of cases through 9 June 2004 that no confirmed instance of detainee abuse resulted from the approved policies.

(2) **Standard:** Standard of treatment for detainees in OPERATION ENDURING FREEDOM (OEF): The Secretary of Defense determined that members of the Taliban militia and members of Al Qaida under the control of US Forces would be treated humanely and, to the extent appropriate and consistent with military necessity, in a manner consistent with the principles of the Geneva Conventions of 1949. The DAIG has therefore used the provisions of the Geneva Conventions as a benchmark against which to measure the treatment provided to detainees by U.S. Forces to determine if detainees were treated humanely. The use of these standards as benchmarks does not state or imply a position for the United States or U.S. Army on the legal status of its operations in OEF.

Chairman, Joint Chiefs of Staff (CJCS) Message dated 211933Z JAN 02, provides the determination regarding the humane treatment of Al Qaida and Taliban detainees. Convention Relative to the Treatment of Prisoners of War of August 12, 1949 (GPW) is the international

treaty that governs the treatment of prisoners of war, and Geneva Convention Relative to the Protection of Civilian Persons in Time of War (GC), August 12, 1949, is the international treaty that governs the treatment of civilian persons in time of war.

As the guidance did not define "humane treatment" but did state that the US would treat members of the Taliban militia and Al Qaida in a manner consistent with the Geneva Conventions, the DAIG determined that it would use Common Article 3 of the GCs as its floor measure of humane treatment, but would also include provisions of the Geneva Convention on the Treatment of Prisoners of War (GPW) and Geneva Convention Relative to the Protection of Civilian Persons in Time of War (GC) as other relevant indicia of "humane treatment." The use of this standard does not state or imply a position for the United States or U.S. Army on the legal status of its operations in OEF.

Standard of treatment for detainees in OPERATION IRAQI FREEDOM (OIF): OIF was an international armed conflict and therefore the provisions of the Geneva Conventions applied. Additionally, the United States was an occupying power and has acted in accordance with the obligations of an occupying power described in the Hague Convention No. IV Respecting the Laws and Customs of War on Land (H.IV), 18 October 1907, including, but not limited to, Articles 43-46 and 50; Geneva Convention Relative to the Treatment of Prisoners of War of August 12, 1949 (GPW), Geneva Convention Relative to the Protection of Civilian Persons in Time of War (GC), 12 August 1949. The GC supplements H.IV, providing the general standard of treatment at Article 27 and specific standards in subsequent Articles.

The minimum treatment provided by Common Article 3 of the Geneva Conventions is: 1) No adverse distinction based upon race, religion, sex, etc.; 2) No violence to life or person; 3) No taking hostages; 4) No degrading treatment; 5) No passing of sentences in absence of fair trial, and; 6) The wounded and sick must be cared for.

The specific language in the CJCS Message for OEF and the GPW/GC and H.IV follows:

CJCS Message dated 211933Z JAN 02, "Paragraph 3. The combatant commanders shall, in detaining Al Qaida and Taliban individuals under control of the Department of Defense, treat them humanely and, to the extent appropriate and consistent with military necessity, in a manner consistent with the principles of the Geneva Conventions of 1949."

GPW/GC, Article 3 (Common Article 3) – "In the case of armed conflict not of an international character occurring in the territory of one of the High Contracting Parties, each party to the conflict shall be bound to apply, as a minimum, the following provisions:

1. Persons taking no active part in the hostilities, including members of armed forces who have laid down their arms and those placed hors de combat by sickness, wounds, detention, or any other cause, shall in all circumstances be treated humanely, without any adverse distinction founded on race, color, religion or faith, sex, birth or wealth, or any other similar criteria.

To this end the following acts are and shall remain prohibited at any time and in any place whatsoever with respect to the above-mentioned persons:

(a) Violence to life and person, in particular murder of all kinds, mutilation, cruel treatment and torture;

(b) Taking of hostages;
(c) Outrages upon personal dignity, in particular, humiliating and degrading treatment;
(d) The passing of sentences and the carrying out of executions without previous judgment pronounced by a regularly constituted court affording all the judicial guarantees which are recognized as indispensable by civilized peoples.

2. The wounded and sick shall be collected and cared for. An impartial humanitarian body, such as the International Committee of the Red Cross, may offer its services to the Parties to the conflict. The Parties to the conflict should further endeavour to bring into force, by means of special agreements, all or part of the other provisions of the present Convention. The application of the preceding provisions shall not affect the legal status of the Parties to the conflict."

Geneva Convention Relative to the Treatment of Prisoners of War, 12 August 1949, Part II, Article 13, requires that enemy prisoners of war (EPWs) be treated humanely at all times; Part III, Section I, Articles 13, 14, and 17, explain the protections afforded EPWs. The specific language in the convention follows:

"Article 13

Prisoners of war must at all times be humanely treated. Any unlawful act or omission by the Detaining Power causing death or seriously endangering the health of a prisoner of war in its custody is prohibited, and will be regarded as a serious breach of the present Convention. In particular, no prisoner of war may be subjected to physical mutilation or to medical or scientific experiments of any kind which are not justified by the medical, dental or hospital treatment of the prisoner concerned and carried out in his interest.

Likewise, prisoners of war must at all times be protected, particularly against acts of violence or intimidation and against insults and public curiosity.

Measures of reprisal against prisoners of war are prohibited.

Article 14

Prisoners of war are entitled in all circumstances to respect for their persons and their honour. Women shall be treated with all the regard due to their sex and shall in all cases benefit by treatment as favourable as that granted to men. Prisoners of war shall retain the full civil capacity which they enjoyed at the time of their capture. The Detaining Power may not restrict the exercise, either within or without its own territory, of the rights such capacity confers except in so far as the captivity requires."

Article 17

Every prisoner of war, when questioned on the subject, is bound to give only his surname, first names and rank, date of birth, and army, regimental, personal or serial number, or failing this, equivalent information. If he willfully infringes this rule, he may render himself liable to a restriction of the privileges accorded to his rank or status.

Each Party to a conflict is required to furnish the persons under its jurisdiction who are liable to become prisoners of war, with an identity card showing the owner's surname, first names, rank, army, regimental, personal or serial number or equivalent information, and date of

birth. The identity card may, furthermore, bear the signature or the fingerprints, or both, of the owner, and may bear, as well, any other information the Party to the conflict may wish to add concerning persons belonging to its armed forces. As far as possible the card shall measure 6.5 x 10 cm. and shall be issued in duplicate. The identity card shall be shown by the prisoner of war upon demand, but may in no case be taken away from him.

No physical or mental torture, nor any other form of coercion, may be inflicted on prisoners of war to secure from them information of any kind whatever. Prisoners of war who refuse to answer may not be threatened, insulted, or exposed to any unpleasant or disadvantageous treatment of any kind.

Prisoners of war who, owing to their physical or mental condition, are unable to state their identity, shall be handed over to the medical service. The identity of such prisoners shall be established by all possible means, subject to the provisions of the preceding paragraph.

The questioning of prisoners of war shall be carried out in a language which they understand."

Geneva Convention Relative to the Protection of Civilian Persons in Time of War, 12 August 1949, Part III, Section I, Articles 31 32, and 100, prohibit coercion and abuse of civilian internees. The specific language in the convention follows:

"Article 31

No physical or moral coercion shall be exercised against protected persons, in particular to obtain information from them or from third parties.

Article 32

The High Contracting Parties specifically agree that each of them is prohibited from taking any measure of such a character as to cause the physical suffering or extermination of protected persons in their hands. This prohibition applies not only to murder, torture, corporal punishment, mutilation and medical or scientific experiments not necessitated by the medical treatment of a protected person but also to any other measures of brutality whether applied by civilian or military agents."

"Article 100

The disciplinary regime in places of internment shall be consistent with humanitarian principles, and shall internees any physical exertion dangerous to their health or involving physical or moral victimization. Identification by tattooing or imprinting signs or markings on the body, is prohibited. In particular, prolonged standing and roll-calls, punishment drill, military drill and manoeuvres, or the reduction of food rations, are prohibited."

Convention Against Torture and Other Cruel, Inhuman or Degrading Treatment or Punishment, 10 December 1984, Part I, Articles 1,2,10,11 and 16(1) define torture (1), the basic responsibilities of states under the convention (2), the requirement for training personnel on this convention (10), the need to conduct systematic reviews of interrogations rules, instructions, methods and practices (11), and the requirement to prevent acts not amounting to "torture"

committed with consent or acquiescence of a public official or other person in an official capacity (16). The specific language in the convention follows:

"Article 1

1. For the purposes of this Convention, the term "torture" means any act by which severe pain or suffering, whether physical or mental, is intentionally inflicted on a person for such purposes as obtaining from him or a third person information or a confession, punishing him for an act he or a third person has committed or is suspected of having committed, or intimidating or coercing him or a third person, or for any reason based on discrimination of any kind, when such pain or suffering is inflicted by or at the instigation of or with the consent or acquiescence of a public official or other person acting in an official capacity. It does not include pain or suffering arising only from, inherent in or incidental to lawful sanctions.

2. This article is without prejudice to any international instrument or national legislation which does or may contain provisions of wider application.

Article 2

1. Each State Party shall take effective legislative, administrative, judicial or other measures to prevent acts of torture in any territory under its jurisdiction.

2. No exceptional circumstances whatsoever, whether a state of war or a threat of war, internal political in stability or any other public emergency, may be invoked as a justification of torture.

3. An order from a superior officer or a public authority may not be invoked as a justification of torture.

Article 10

1. Each State Party shall ensure that education and information regarding the prohibition against torture are fully included in the training of law enforcement personnel, civil or military, medical personnel, public officials and other persons who may be involved in the custody, interrogation or treatment of any individual subjected to any form of arrest, detention or imprisonment.

2. Each State Party shall include this prohibition in the rules or instructions issued in regard to the duties and functions of any such person.

Article 11

Each State Party shall keep under systematic review interrogation rules, instructions, methods and practices as well as arrangements for the custody and treatment of persons subjected to any form of arrest, detention or imprisonment in any territory under its jurisdiction, with a view to preventing any cases of torture.

Article 16 (1)

Each State Party shall undertake to prevent in any territory under its jurisdiction other acts of cruel, inhuman or degrading treatment or punishment which do not amount to torture as

defined in article 1, when such acts are committed by or at the instigation of or with the consent or acquiescence of a public official or other person acting in an official capacity. In particular, the obligations contained in articles 10, 11, 12 and 13 shall apply with the substitution for references to torture of references to other forms of cruel, inhuman or degrading treatment or punishment.

US Reservations, Declarations and Understandings the Convention Against Torture. The United States Senate ratified the Convention Against Torture subject to certain reservations, declarations and understandings. Pertinent reservations and understandings are as follow:

Senate Reservations: (136 Cong Rec S 17486):

The Senate's advice and consent is subject to the following reservations:

(1) That the United States considers itself bound by the obligation under article 16 to prevent 'cruel, inhuman or degrading treatment or punishment', only insofar as the term 'cruel, inhuman or degrading treatment or punishment' means the cruel, unusual and inhumane treatment or punishment prohibited by the Fifth, Eighth, and/or Fourteenth Amendments to the Constitution of the United States.

Senate Understandings (136 Cong Rec S 17486):

The Senate's advice and consent is subject to the following understandings, which shall apply to the obligations of the United States under this Convention:

(1) (a) That with reference to article 1, the United States understands that, in order to constitute torture, an act must be specifically intended to inflict severe physical or mental pain or suffering and that mental pain or suffering refers to prolonged mental harm caused by or resulting from (1) the intentional infliction or threatened infliction of severe physical pain or suffering; (2) the administration or application, or threatened administration or application, of mind altering substances or other procedures calculated to disrupt profoundly the senses or the personality; (3) the threat of imminent death; or (4) the threat that another person will imminently be subjected to death, severe physical pain or suffering, or the administration or application of mind altering substances or other procedures calculated to disrupt profoundly the senses or personality.

(b) That the United States understands that the definition of torture in article 1 is intended to apply only to acts directed against persons in the offender's custody or physical control.

(c) That with reference to article 1 of the Convention, the United States understands that 'sanctions' includes judicially-imposed sanctions and other enforcement actions authorized by United States law or by judicial interpretation of such law provided that such sanctions or actions are not clearly prohibited under international law.

(d) That with reference to article 1 of the Convention, the United States understands that the term 'acquiescence' requires that the public official, prior to the activity constituting torture, have awareness of such activity and thereafter breach his legal responsibility to intervene to prevent such activity.

(e) That with reference to article 1 of the Convention, the United States understands that noncompliance with applicable legal procedural standards does not per se constitute torture.

Domestic Criminal Law: US Domestic Criminal law reflects treaty obligations and ratification reservations and understandings regarding torture in the adoption of 18 USCS §§2340, 2340A, which state:

18 USC§ 2340 Definitions

As used in this chapter [18 USCS §§ 2340 et seq.]-

(1) "torture" means an act committed by a person acting under the color of law specifically intended to inflict severe physical or mental pain or suffering (other than pain or suffering incidental to lawful sanctions) upon another person within his custody or physical control;

(2) "severe mental pain or suffering" means the prolonged mental harm caused by or resulting from-

(A) the intentional infliction or threatened infliction of severe physical pain or suffering;

(B) the administration or application, or threatened administration or application, of mind-altering substances or other procedures calculated to disrupt profoundly the senses or the personality;

(C) the threat of imminent death;

(D) the threat that another person will imminently be subjected to death, severe physical pain or suffering, or the administration or application of mind-altering substances or other procedures calculated to disrupt profoundly the senses or personality; and

(3) "United States" includes all areas under the jurisdiction of the United States including any of the places described in sections 5 and 7 of this title and section 46501(2) of title 49.

§ 2340A. Torture

(a) Offense. Whoever outside the United States commits or attempts to commit torture shall be fined under this title or imprisoned not more than 20 years, or both, and if death results to any person from conduct prohibited by this subsection, shall be punished by death or imprisoned for any term of years or for life.

(b) Jurisdiction. There is jurisdiction over the activity prohibited in subsection (a) if--

(1) the alleged offender is a national of the United States; or

(2) the alleged offender is present in the United States, irrespective of the nationality of the victim or alleged offender.

(c) Conspiracy. A person who conspires to commit an offense under this section shall be subject to the same penalties (other than the penalty of death) as the penalties prescribed for the offense, the commission of which was the object of the conspiracy.

Field Manual (FM) 34-52, Intelligence Interrogation, 28 September 1992, Chapter 1, explains the prohibitions against use of torture or coercion. Chapter 3 describes the interrogation approaches and techniques used by trained Army interrogators. The specific language in the field manual follows:

Chapter 1 – "One of the significant means used by the intelligence staff is the interrogation of the following:

- EPWs.
- Captured insurgents.
- Civilian internees.
- Other captured, detained, or retained persons.
- Foreign deserters or other persons of intelligence interest.

These persons are protected by the Geneva Conventions for the Protection of War Victims of August 12, 1949, as they relate to captured wounded and sick enemy personnel (GWS), retained enemy medical personnel and chaplains (GWS), enemy prisoners of war (GPW), and civilian internees (GC). Captured insurgents and other detained personnel whose status is not clear, such as suspected terrorists, are entitled to PW protection until their precise status has been determined by competent authority.

In conducting intelligence interrogations, the J2, G2, or S2 has primary staff responsibility to ensure these activities are performed in accordance with the GWS, GPW, and GC, as well as US policies, regarding the treatment and handling of the above-mentioned persons.

The GWS, GPW, GC, and US policy expressly prohibit acts of violence or intimidation, including physical or mental torture, threats, insults, or exposure to inhumane treatment as a means of or aid to interrogation.

Such illegal acts are not authorized and will not be condoned by the US Army. Acts in violation of these prohibitions are criminal acts punishable under the UCMJ. If there is doubt as to the legality of a proposed form of interrogation not specifically authorized in this manual, the advice of the command judge advocate should be sought before using the method in question.

Experience indicates that the use of prohibited techniques is not necessary to gain the cooperation of interrogation sources. Use of torture and other illegal methods is a poor technique that yields unreliable results, may damage subsequent collection efforts, and can induce the source to say what he thinks the interrogator wants to hear.

Revelation of use of torture by US personnel will bring discredit upon the US and its armed forces while undermining domestic and international support for the war effort. It also may place US and allied personnel in enemy hands at a greater risk of abuse by their captors. Conversely, knowing the enemy has abused US and allied PWs does not justify using methods of interrogation specifically prohibited by the GWS, GPW, or GC, and US policy.

Limitations on the use of methods identified herein as expressly prohibited should not be confused with psychological ploys, verbal trickery, or other nonviolent or noncoercive ruses used by the interrogator in the successful interrogation of hesitant or uncooperative sources.

The psychological techniques and principles in this manual should neither be confused with, nor construed to be synonymous with, unauthorized techniques such as brainwashing, physical or mental torture, or any other form of mental coercion to include drugs that may induce lasting and permanent mental alteration and damage.

Physical or mental torture and coercion revolve around eliminating the source's free will, and are expressly prohibited by GWS, Article 13; GPW, Articles 13 and 17; and GC, Articles 31 and 32. Torture is defined as the infliction of intense pain to body or mind to extract a confession or information, or for sadistic pleasure.

Examples of physical torture include—

- Electric shock.
- Infliction of pain through chemicals or bondage (other than legitimate use of restraints to prevent escape).
- Forcing an individual to stand, sit, or kneel in abnormal positions for prolonged periods of time.
- Food deprivation.
- Any form of beating.

Examples of mental torture include—

- Mock executions.
- Abnormal sleep deprivation.
- Chemically induced psychosis.

Coercion is defined as actions designed to unlawfully induce another to compel an act against one's will. Examples of coercion include—

- Threatening or implying physical or mental torture to the subject, his family, or others to whom he owes loyalty.
- Intentionally denying medical assistance or care in exchange for the information sought or other cooperation.
- Threatening or implying that other rights guaranteed by the GWS, GPW, or GC will not be provided unless cooperation is forthcoming.

Chapter 3 – "The number of approaches used is limited only by the interrogator's skill. Almost any ruse or deception is usable as long as the provisions of the GPW, as outlined in Figure 1-4, are not violated.

An interrogator must not pass himself off as a medic, chaplain, or as a member of the Red Cross (Red Crescent or Red Lion). To every approach technique, there are literally hundreds of possible variations, each of which can be developed for a specific situation or source. The variations are limited only by the interrogator's personality, experience, ingenuity, and imagination.

3-7 There are four primary factors that must be considered when selecting tentative approaches:

- The source's mental and physical state. Is the source injured, angry, crying, arrogant, cocky, or frightened? If so, how can this state be best exploited during interrogation.
- The source's background. What is the source's age and level of military or civilian experience.
- The objective of the interrogation. How much time is available for the interrogation? Is the commander interested only in specific areas (PIR, IR, SIR)? Is this source knowledgeable enough to require a full OB interrogation?
- The interrogator himself. What abilities does he have that can be brought into play? What weaknesses does he have that may interfere with the interrogation? Can his personality adapt to the personality of the source?

APPROACH COMBINATIONS

With the exception of the direct approach, no other approach is effective by itself. Interrogators use different approach techniques or combine them into a cohesive, logical technique. Smooth transitions, sincerity, logic, and conviction almost always make a strategy work. The lack of will undoubtedly dooms it to failure. Some examples of combinations are—

Direct—futility—incentive.

Direct—futility—love of comrades.

Direct—fear-up (mild)—incentive.

The number of combinations are unlimited. Interrogators must carefully choose the approach strategy in the planning and preparation phase and listen carefully to what the source is saying (verbally or nonverbally) for leads the strategy chosen will not work. When this occurs, the interrogator must adapt to approaches he believes will work in gaining the source's cooperation.

The approach techniques are not new nor are all the possible or acceptable techniques discussed below. Everything the interrogator says and does must be in concert with the GWS, GPW, GC, and UCMJ. The approaches which have proven effective are—

- Direct.
- Incentive.
- Emotional.
- Increased fear-up.
- Pride and ego.

Direct Approach

The interrogator asks questions directly related to information sought, making no effort to conceal the interrogation's purpose. The direct approach, always the first to be attempted, is used on EPWs or detainees who the interrogator believes will cooperate.

This may occur when interrogating an EPW or detainee who has proven cooperative during initial screening or first interrogation. It may also be used on those with little or no security training. The direct approach works best on lower enlisted personnel, as they have little or no resistance training and have had minimal security training.

The direct approach is simple to use, and it is possible to obtain the maximum amount of information in the minimum amount of time. It is frequently employed at lower echelons when the tactical situation precludes selecting other techniques, and where the EPW's or detainee's mental state is one of confusion or extreme shock. Figure C-3 contains sample questions used in direct questioning.

The direct approach is the most effective. Statistics show in World War II, it was 90 percent effective. In Vietnam and OPERATIONS URGENT FURY, JUST CAUSE, and DESERT STORM, it was 95 percent effective.

Incentive Approach

The incentive approach is based on the application of inferred discomfort upon an EPW or detainee who lacks willpower. The EPW or detainee may display fondness for certain luxury items such as candy, fruit, or cigarettes. This fondness provides the interrogator with a positive means of rewarding the EPW or detainee for cooperation and truthfulness, as he may give or withhold such comfort items at his discretion. Caution must be used when employing this technique because—

- Any pressure applied in this manner must not amount to a denial of basic human needs under any circumstances. [NOTE: Interrogators may not withhold a source's rights under the GPW, but they can withhold a source's privileges.] Granting incentives must not infringe on these rights, but they can be things to which the source is already entitled. This can be effective only if the source is unaware of his rights or privileges.
- The EPW or detainee might be tempted to provide false or inaccurate information to gain the desired luxury item or to stop the interrogation.

The GPW, Article 41, requires the posting of the convention contents in the EPW's own language. This is an MP responsibility.

Incentives must seem to be logical and possible. An interrogator must not promise anything that cannot be delivered. Interrogators do not make promises, but usually infer them while sidestepping guarantees.

For example, if an interrogator made a promise he could not keep and he or another interrogator had to talk with the source again, the source would not have any trust and would probably not cooperate. Instead of clearly promising a certain thing, such as political asylum, an interrogator will offer to do what he can to help achieve the source's desired goal; as long as the source cooperates.

As with developing rapport, the incentive approach can be broken down into two incentives. The determination rests on when the source expects to receive the incentive offered.

- Short term—received immediately; for example, letter home, seeing wounded buddies.
- Long term—received within a period of time; for example, political asylum.

Emotional Approach

Through EPW or detainee observation, the interrogator can often identify dominant emotions which motivate. The motivating emotion may be greed, love, hate, revenge, or others. The interrogator employs verbal and emotional ruses in applying pressure to the EPW's or detainee's dominant emotions.

One major advantage of this technique is it is versatile and allows the interrogator to use the same basic situation positively and negatively.

For example, this technique can be used on the EPW who has a great love for his unit and fellow soldiers. The interrogator may take advantage of this by telling the EPW that by providing pertinent information, he may shorten the war or battle in progress and save many of his comrades' lives, but his refusal to talk may cause their deaths. This places the burden on the EPW or detainee and may motivate him to seek relief through cooperation.

Conversely, this technique can also be used on the EPW or detainee who hates his unit because it withdrew and left him to be captured, or who feels he was unfairly treated in his unit. In such cases, the interrogator can point out that if the EPW cooperate and specifies the unit's location, the unit can be destroyed, thus giving the EPW an opportunity for revenge. The interrogator proceeds with this method in a very formal manner.

This approach is likely to be effective with the immature and timid EPW.

Emotional Love Approach. For the emotional love approach to be successful, the interrogator must focus on the anxiety felt by the source about the circumstances in which he finds himself. The interrogator must direct the love the source feels toward the appropriate object: family, homeland, or comrades. If the interrogator can show the source what the source himself can do to alter or improve his situation, the approach has a chance of success.

This approach usually involves some incentive such as communication with the source's family or a quicker end to the war to save his comrades' lives. A good interrogator will usually orchestrate some futility with an emotional love approach to hasten the source's reaching the breaking point.

Sincerity and conviction are critical in a successful attempt at an emotional love approach as the interrogator must show genuine concern for the source, and for the object at which the interrogator is directing the source's emotion.

If the interrogator ascertains the source has great love for his unit and fellow soldiers, the interrogator can effectively exploit the situation. This places a burden on the source and may motivate him to seek relief through cooperation with the interrogator.

Emotional Hate Approach. The emotional hate approach focuses on any genuine hate, or possibly a desire for revenge, the source may feel. The interrogator must ascertain exactly what it is the source may hate so the emotion can be exploited to override the source's rational

side. The source may have negative feelings about his country's regime, immediate superiors, officers in general, or fellow soldiers.

This approach is usually most effective on members of racial or religious minorities who have suffered discrimination in military and civilian life. If a source feels he has been treated unfairly in his unit, the interrogator can point out that, if the source cooperates and divulges the location of that unit, the unit can be destroyed, thus affording the source revenge.

By using a conspiratorial tone of voice, the interrogator can enhance the value of this technique. Phrases, such as "You owe them no loyalty for the way they treated you," when used appropriately, can expedite the success of this technique.

Do not immediately begin to berate a certain facet of the source's background or life until your assessment indicates the source feels a negative emotion toward it.

The emotional hate approach can be used more effectively by drawing out the source's negative emotions with questions that elicit a thought-provoking response. For example, "Why do you think they allowed you to be captured?" or "Why do you think they left you to die?" Do not berate the source's forces or homeland unless certain negative emotions surface.

Many sources may have great love for their country, but may hate the regime in control. The emotional hate approach is most effective with the immature or timid source who may have no opportunity up to this point for revenge, or never had the courage to voice his feelings.

Fear-Up Approach

The fear-up approach is the exploitation of a source's preexisting fear during the period of capture and interrogation. The approach works best with young, inexperienced sources, or sources who exhibit a greater than normal amount of fear or nervousness. A source's fear may be justified or unjustified. For example, a source who has committed a war crime may justifiably fear prosecution and punishment. In contrast, a source who has been indoctrinated by enemy propaganda may unjustifiably fear that he will suffer torture or death in or hand if captured.

This approach has the greatest potential to violate the law of war. Great care must be taken to avoid threatening or coercing a source which is in violation of the GPW, Article 17.

It is critical the interrogator distinguish what the source fears in order to exploit that fear. The way in which the interrogator exploits the source's fear depends on whether the source's fear is justified or unjustified.

Fear-Up (Harsh). In this approach, the interrogator behaves in an overpowering manner with a loud and threatening voice. The interrogator may even feel the need to throw objects across the room to heighten the source's implanted feelings of fear. Great care must be taken when doing this so any actions would not violate the prohibition on coercion and threats contained in the GPW, Article 17.

This technique is to convince the source he does indeed have something to fear; that he has no option but to cooperate. A good interrogator will implant in the source's mind that the interrogator himself is not the object to be feared, but is a possible way out of the trap.

Use the confirmation of fear only on sources whose fear is justified. During this approach, confirm to the source that he does indeed have a legitimate fear. Then convince the source that you are the source's best or only hope in avoiding or mitigating the object of his fear, such as punishment for his crimes.

You must take great care to avoid promising actions that are not in your power to grant. For example, if the source has committed a war crime, inform the source that the crime has been reported to the appropriate authorities and that action is pending. Next inform the source that, if he cooperates and tells the truth, you will report that he cooperated and told the truth to the appropriate authorities. You may add that you will also report his lack of cooperation. You may not promise that the charges against him will be dismissed because you have no authority to dismiss the charges.

Fear-Up (Mild). This approach is better suited to the strong, confident type of interrogator; there is generally no need to raise the voice or resort to heavy-handed, table-banging.

For example, capture may be a result of coincidence—the soldier was caught on the wrong side of the border before hostilities actually commenced (he was armed, he could be a terrorist)—or as a result of his actions (he surrendered contrary to his military oath and now a traitor to his country, and his forces will take care of the disciplinary action).

The fear-up (mild) approach must be credible. It usually involves some logical incentive.

In most cases, a loud voice is not necessary. The actual fear is increased by helping the source realize the unpleasant consequences the facts may cause and by presenting an alternative, which, of course, can be brought about by answering some simple questions.

The fear-up (harsh) approach is usually a dead end, and a wise interrogator may want to keep it in reserve as a trump card. After working to increase the source's fear, it would be difficult to convince him everything will be all right if the approach is not successful.

Fear-Down Approach

This technique is nothing more than calming the source and convincing him he will be properly and humanely treated, or telling him the war for him is mercifully over and he need not go into combat again. When used with a soothing, calm tone of voice, this often creates rapport and usually nothing else is needed to get the source to cooperate.

While calming the source, it is a good idea to stay initially with nonpertinent conversation and to avoid the subject which has caused the source's fear. This works quickly in developing rapport and communication, as the source will readily respond to kindness.

When using this approach, it is important the interrogator relate to the source at his perspective level and not expect the source to come up to the interrogator's level.

If the EPW or detainee is so frightened he has withdrawn into a shell or regressed to a less threatening state of mind, the interrogator must break through to him. The interrogator can do this by putting himself on the same physical level as the source; this may require some physical contact. As the source relaxes and begins to respond to kindness, the interrogator can begin asking pertinent questions.

This approach technique may backfire if allowed to go too far. After convincing the source he has nothing to fear, he may cease to be afraid and may feel secure enough to resist the interrogator's pertinent question. If this occurs, reverting to a harsher approach technique usually will bring the desired result quickly.

The fear-down approach works best if the source's fear is unjustified. During this approach, take specific actions to reduce the source's unjustified fear. For example, if the source believes that he will be abused while in your custody, make extra efforts to ensure that the source is well cared for, fed, and appropriately treated.

Once the source is convinced that he has no legitimate reason to fear you, he will be more inclined to cooperate. The interrogator is under no duty to reduce a source's unjustified fear. The only prohibition is that the interrogator may not say or do anything that directly or indirectly communicates to the source that he will be harmed unless he provides the requested information.

These applications of the fear approach may be combined to achieve the desired effect. For example, if a source has justified and unjustified fears, you may initially reduce the source's unfounded fears, and then confirm his legitimate fears. Again, the source should be convinced the interrogator is his best or only hope in avoiding or mitigating the object of his fear.

Pride and Ego Approach

The strategy of this approach is to trick the source into revealing desired information by goading or flattering him. It is effective with sources who have displayed weakness or feelings of inferiority. A real or imaginary deficiency voiced about the source, loyalty to his organization, or any other feature can provide a basis for this technique.

The interrogator accuses the source of weakness or implies he is unable to do a certain thing. This type of source is also prone to excuses and reasons why he did or did not do a certain thing, often shifting the blame to others. An example is opening the interrogation with the question, "Why did you surrender so easily when you could have escaped by crossing the nearby ford in the river?"

The source is likely to provide a basis for further questions or to reveal significant intelligence information if he attempts to explain his surrender in order to vindicate himself. He may give an answer such as, "No one could cross the ford because it is mined."

This technique can also be employed in another manner--by flattering the source into admitting certain information in order to gain credit. For example, while interrogating a suspected saboteur, the interrogator states: "This was a smooth operation. I have seen many previous attempts fail. I bet you planned this. Who else but a clever person like you would have planned it? When did you first decide to do the job?"

This technique is especially effective with the source who has been looked down upon by his superiors. The source has the opportunity to show someone he is intelligent.

A problem with the pride and ego approach is it relies on trickery. The source will eventually realize he has been tricked and may refuse to cooperate further. If this occurs, the interrogator can easily move into a fear-up approach and convince the source the questions he has already answered have committed him, and it would be useless to resist further.

The interrogator can mention it will be reported to the source's forces that he has cooperated fully with the enemy, will be considered a traitor, and has much to fear if he is returned to his forces.

This may even offer the interrogator the option to go into a love-of-family approach where the source must protect his family by preventing his forces from learning of his duplicity or collaboration. Telling the source you will not report that he talked or that he was a severe discipline problem is an incentive that may enhance the effectiveness of the approach.

Pride and Ego-Up Approach. This approach is most effective on sources with little or no intelligence, or on those who have been looked down upon for a long time. It is very effective on low-ranking enlisted personnel and junior grade officers, as it allows the source to finally show someone he does indeed have some "brains."

The source is constantly flattered into providing certain information in order to gain credit. The interrogator must take care to use a flattering somewhat-in-awe tone of voice, and speak highly of the source throughout this approach. This quickly produces positive feelings on the source's part, as he has probably been looking for this type of recognition all of his life.

The interrogator may blow things out of proportion using items from the source's background and making them seem noteworthy or important. As everyone is eager to hear praise, the source will eventually reveal pertinent information to solicit more laudatory comments from the interrogator.

Effective targets for a successful pride and ego-up approach are usually the socially accepted reasons for flattery, such as appearance and good military bearing. The interrogator should closely watch the source's demeanor for indications the approach is working. Some indications to look for are—

- Raising of the head.
- A look of pride in the eyes.
- Swelling of the chest.
- Stiffening of the back.

Pride and Ego-Down Approach. This approach is based on attacking the source's sense of personal worth. Any source who shows any real or imagined inferiority or weakness about himself, loyalty to his organization, or captured under embarrassing circumstances, can be easily broken with this approach technique.

The objective is for the interrogator to pounce on the source's sense of pride by attacking his loyalty, intelligence, abilities, leadership qualities, slovenly appearance, or any other perceived weakness. This will usually goad the source into becoming defensive, and he will try to convince the interrogator he is wrong. In his attempt to redeem his pride, the source will usually involuntarily provide pertinent information in attempting to vindicate himself.

A source susceptible to this approach is also prone to make excuses and give reasons why he did or did not do a certain thing, often shifting the blame to others. If the interrogator uses a sarcastic, caustic tone of voice with appropriate expressions of distaste or disgust, the source will readily believe him. Possible targets for the pride and ego-down approach are the source's—

- Loyalty.
- Technical competence.
- Leadership abilities.
- Soldierly qualities.
- Appearance.

The pride and ego-down approach is also a dead end in that, if unsuccessful, it is difficult for the interrogator to recover and move to another approach and reestablish a different type of rapport without losing all credibility.

Futility

In this approach, the interrogator convinces the source that resistance to questioning is futile. When employing this technique, the interrogator must have factual information. These facts are presented by the interrogator in a persuasive, logical manner. He should be aware of and able to exploit the source's psychological and moral weaknesses, as well as weaknesses inherent in his society.

The futility approach is effective when the interrogator can play on doubts that already exist in the source's mind. There are different variations of the futility approach. For example:

- Futility of the personal situation—"You are not finished here until you answer the question."
- Futility in that "everyone talks sooner or later."
- Futility of the battlefield situation.
- Futility in the sense if the source does not mind talking about history, why should he mind talking about his missions, they are also history.

If the source's unit had run out of supplies (ammunition, food, or fuel), it would be somewhat easy to convince him all of his forces are having the same logistical problems. A soldier who has been ambushed may have doubts as to how he was attacked so suddenly. The interrogator should be able to talk him into believing that the interrogator's forces knew of the EPW's unit location, as well as many more units.

The interrogator might describe the source's frightening recollections of seeing death on the battlefield as an everyday occurrence for his forces. Factual or seemingly factual information must be presented in a persuasive, logical manner, and in a matter-of-fact tone of voice.

Making the situation appear hopeless allows the source to rationalize his actions, especially if that action is cooperating with the interrogator. When employing this technique, the interrogator must not only have factual information but also be aware of and exploit the source's psychological, moral, and sociological weaknesses.

Another way of using the futility approach is to blow things out of proportion. If the source's unit was low on, or had exhausted, all food supplies, he can be easily led to believe all

of his forces had run out of food. If the source is hinging on cooperating, it may aid the interrogation effort if he is told all the other source's have cooperated.

The futility approach must be orchestrated with other approach techniques (for example, love of comrades). A source who may want to help save his comrades' lives may be convinced the battlefield situation is hopeless and they will die without his assistance.

The futility approach is used to paint a bleak picture for the prisoner, but it is not effective in and of itself in gaining the source's cooperation.

We Know All

This approach may be employed in conjunction with the "file and dossier" technique (discussed below) or by itself. If used alone, the interrogator must first become thoroughly familiar with available data concerning the source. To begin the interrogation, the interrogator asks questions based on this known data. When the source hesitates, refuses to answer, or provides an incorrect or incomplete reply, the interrogator provides the detailed answer.

When the source begins to give accurate and complete information, the interrogator interjects questions designed to gain the needed information. Questions to which answers are already known are also asked to test the source's truthfulness and to maintain the deception that the information is already known. By repeating this procedure, the interrogator convinces the source that resistance is useless as everything is already known.

After gaining the source's cooperation, the interrogator still tests the extent of cooperation by periodically using questions to which he has the answers; this is very necessary. If the interrogator does not challenge the source when he is lying, the source will know everything is not known, and he has been tricked. He may then provide incorrect answers to the interrogator's questions.

There are some inherent problems with the use of the "we know all" approach. The interrogator is required to prepare everything in detail, which is time consuming. He must commit much of the information to memory, as working from notes may show the limits of the information actually known.

File and Dossier

The file and dossier approach is used when the interrogator prepares a dossier containing all available information obtained from documents concerning the source or his organization. Careful arrangement of the material within the file may give the illusion it contains more data than actually there. The file may be padded with extra paper, if necessary. Index tabs with titles such as education, employment, criminal record, military service, and others are particularly effective.

The interrogator confronts the source with the dossiers at the beginning of the interrogation and explains intelligence has provided a complete record of every significant happening in the source's life; therefore, it would be useless to resist. The interrogator may read a few selected bits of known data to further impress the source.

If the technique is successful, the source will be intimidated by the size of the file, conclude everything is known, and resign himself to complete cooperation. The success of this

technique is largely dependent on the naiveté of the source, volume of data on the subject, and skill of the interrogator in convincing the source.

Establish Your Identity

This approach is especially adaptable to interrogation. The interrogator insists the source has been correctly identified as an infamous individual wanted by higher authorities on serious charges, and he is not the person he purports to be. In an effort to clear himself of this allegation, the source makes a genuine and detailed effort to establish or substantiate his true identity. In so doing, he may provide the interrogator with information and leads for further development.

The "establish your identity" approach was effective in Viet Nam with the Viet Cong and in OPERATIONS JUST CAUSE and DESERT STORM.

This approach can be used at tactical echelons. The interrogator must be aware if it is used in conjunction with the file and dossier approach, as it may exceed the tactical interrogator's preparation resources.

The interrogator should initially refuse to believe the source and insist he is the criminal wanted by the ambiguous higher authorities. This will force the source to give even more detailed information about his unit in order to convince the interrogator he is who he says he is. This approach works well when combined with the "futility" or "we know all" approach.

Repetition

This approach is used to induce cooperation from a hostile source. In one variation of this approach, the interrogator listens carefully to a source's answer to a question, and then repeats the question and answer several times. He does this with each succeeding question until the source become so thoroughly bored with the procedure he answers questions fully and candidly to satisfy the interrogator and gain relief from the monotony of this method.

The repetition technique must be judiciously used, as it will generally be ineffective when employed against introverted sources or those having great self-control. In fact, it may provide an opportunity for a source to regain his composure and delay the interrogation. In this approach, the use of more than one interrogator or a tape recorder has proven effective.

Rapid Fire

This approach involves a psychological ploy based upon the principles that—

- Everyone likes to be heard when he speaks.
- It is confusing to be interrupted in mid-sentence with an unrelated question.

This approach may be used by one or simultaneously by two or more interrogators in questioning the same source. In employing this technique, the interrogator asks a series of questions in such a manner that the source does not have time to answer a question completely before the next one is asked.

This confuses the source and he will tend to contradict himself, as he has little time to formulate his answers. The interrogator then confronts the source with the inconsistencies causing further contradictions.

In many instances, the source will begin to talk freely in an attempt to explain himself and deny the interrogator's claims of inconsistencies. In this attempt, the source is likely to reveal more than he intends, thus creating additional leads for further exploitation. This approach may be orchestrated with the pride and ego-down or fear-up approaches.

Besides extensive preparation, this approach requires an experienced and competent interrogator, with comprehensive case knowledge and fluency in the source's language.

Silent

This approach may be successful when used against the nervous or confident source. When employing this technique, the interrogator says nothing to the source, but looks him squarely in the eye, preferably with a slight smile on his face. It is important not to look away from the source but force him to break eye contact first.

The source may become nervous, begin to shift in his chair, cross and recross his legs, and look away. He may ask questions, but the interrogator should not answer until he is ready to break the silence. The source may blurt out questions such as, "Come on now, what do you want with me?"

When the interrogator is ready to break silence, he may do so with some nonchalant questions such as, "You planned this operation for a long time, didn't you? Was it your idea?" The interrogator must be patient when using this technique. It may appear the technique is not succeeding, but usually will when given a reasonable chance.

Change of Scene

The idea in using this approach is to get the source away from the atmosphere of an interrogation room or setting. If the interrogator confronts a source who is apprehensive or frightened because of the interrogation environment, this technique may prove effective.

In some circumstances, the interrogator may be able to invite the source to a different setting for coffee and pleasant conversation. During the conversation in this more relaxed environment, the interrogator steers the conversation to the topic of interest. Through this somewhat indirect method, he attempts to elicit the desired information. The source may never realize he is being interrogated.

Another example in this approach is an interrogator poses as a compound guard and engages the source in conversation, thus eliciting the desired information."

i. **Finding 9:**

(1) Finding: Interviewed leaders and Soldiers stated the unit's morale (71%) and command climate (68%) had steadily improved due to competent leadership, caring of Soldiers by leaders, and better working and living conditions as the theater matured.

(2) Standard: Army Regulation (AR) 600-20, Army Command Policy, 13 May 2002, Chapter 1, paragraph 1-5, subparagraph c (1) and (4)(c), prescribes the policies and responsibilities of command. The specific language in the regulation follows:

"c. Characteristics of command leadership.

(1) Commanders and other leaders committed to the professional Army ethic promote a positive environment. If leaders show loyalty to their soldiers, the Army, and the Nation, they earn the loyalty of their soldiers. If leaders consider their soldiers' needs and care for their well-being, and if they demonstrate genuine concern, these leaders build a positive command climate.

"(4) Professionally competent leaders will develop respect for their authority by-

"(c) Properly training their soldiers and ensuring that both soldiers and equipment are in the proper state of readiness at all times. Commanders should assess the command climate periodically to analyze the human dimension of combat readiness. Soldiers must be committed to accomplishing the mission through the unit cohesion developed as a result of a healthy leadership climate established by the command. Leaders at all levels promote the individual readiness of their soldiers by developing competence and confidence in their subordinates. In addition to being mentally, physically, tactically, and technically competent, soldiers must have confidence in themselves, their equipment, their peers, and their leaders. A leadership climate in which all soldiers are treated with fairness, justice, and equity will be crucial to development of this confidence within soldiers. Commanders are responsible for developing disciplined and cohesive units sustained at the highest readiness level possible."

j. Finding 10:

(1) Finding: Detainee administration, internment, and intelligence exploitation policy and doctrine does not address detainee operations conducted in the current operating environment, which has a higher demand for human intelligence exploitation at the tactical level and the need for additional classifications of detainees.

(2) Standard: Standard of treatment for detainees in OPERATION ENDURING FREEDOM (OEF): Chairman, Joint Chiefs of Staff (CJCS) message dated 211933Z JAN 02 states that members of the Taliban militia and members of Al Qaida under the control of US Forces would be treated humanely and, to the extent appropriate and consistent with military necessity, in a manner consistent with the principles of the Geneva Conventions of 1949. The DAIG has therefore used the provisions of the Geneva Conventions as a benchmark against which to measure the treatment provided to detainees by U.S. Forces to determine if detainees were treated humanely. The use of these standards as benchmarks does not state or imply a position for the United States or U.S. Army on the legal status of its operations in OEF.

CJCS Message dated 211933Z JAN 02, provides the determination regarding the humane treatment of Al Qaida and Taliban detainees. Convention Relative to the Treatment of Prisoners of War of August 12, 1949 (GPW) is the international treaty that governs the treatment of prisoners of war; and Geneva Convention Relative to the Protection of Civilian Persons in Time of War (GC), August 12, 1949 is the international treaty that governs the treatment of civilian persons in time of war.

As the guidance did not define "humane treatment" but did state that the US would treat members of the Taliban militia and Al Qaida in a manner consistent with the Geneva Conventions, the DAIG determined that it would use Common Article 3 of the GCs as its floor measure of humane treatment, but would also include provisions of the Geneva Convention on the Treatment of Prisoners of War (GPW) and Geneva Convention Relative to the Protection of Civilian Persons in Time of War (GC) as other relevant indicia of "humane treatment." The use of this standard does not state or imply a position for the United States or U.S. Army on the legal status of its operations in OEF.

Standard of treatment for detainees in OPERATION IRAQI FREEDOM (OIF): OIF was an international armed conflict and therefore the provisions of the Geneva Conventions applied. Additionally, the United States was an occupying power and has acted in accordance with the obligations of an occupying power described in the Hague Convention No. IV Respecting the Laws and Customs of War on Land (H.IV), Oct. 18, 1907, including, but not limited to Articles 43-46 and 50; Geneva Convention Relative to the Treatment of Prisoners of War of August 12, 1949 (GPW), Geneva Convention Relative to the Protection of Civilian Persons in Time of War (GC), August 12, 1949. The GC supplements H.IV, providing the general standard of treatment at Article 27 and specific standards in subsequent Articles.

The minimum treatment provided by Common Article 3 of the Geneva Conventions is: (1) No adverse distinction based upon race, religion, sex, etc.; (2) No violence to life or person; (3) No taking hostages; (4) No degrading treatment; (5) No passing of sentences in absence of fair trial, and; (6) The wounded and sick must be cared for.

The specific language in the CJCS Message for OEF and the GPW/GC and H.IV follows:

CJCS Message dated 211933Z JAN 02, "Paragraph 3. The combatant commanders shall, in detaining Al Qaida and Taliban individuals under the control of the Department of Defense, treat them humanely and, to the extent appropriate and consistent with military necessity, in a manner consistent with the principles of the Geneva Conventions of 1949."

GPW/GC, Article 3 (Common Article 3) – "In the case of armed conflict not of an international character occurring in the territory of one of the High Contracting Parties, each party to the conflict shall be bound to apply, as a minimum, the following provisions:

1. Persons taking no active part in the hostilities, including members of armed forces who have laid down their arms and those placed hors de combat by sickness, wounds, detention, or any other cause, shall in all circumstances be treated humanely, without any adverse distinction founded on race, color, religion or faith, sex, birth or wealth, or any other similar criteria.

To this end the following acts are and shall remain prohibited at any time and in any place whatsoever with respect to the above-mentioned persons:

- (a) Violence to life and person, in particular murder of all kinds, mutilation, cruel treatment and torture;
- (b) Taking of hostages;
- (c) Outrages upon personal dignity, in particular, humiliating and degrading treatment;

(d) The passing of sentences and the carrying out of executions without previous judgment pronounced by a regularly constituted court affording all the judicial guarantees which are recognized as indispensable by civilized peoples.

2. The wounded and sick shall be collected and cared for. An impartial humanitarian body, such as the International Committee of the Red Cross, may offer its services to the Parties to the conflict. The Parties to the conflict should further endeavour to bring into force, by means of special agreements, all or part of the other provisions of the present Convention. The application of the preceding provisions shall not affect the legal status of the Parties to the conflict."

The following specific provisions of GPW and GC apply:

"Article 18 – All effects and articles of personal use, except arms, horses, military equipment and military documents, shall remain in the possession of prisoners of war, likewise their metal helmets and gas masks and like articles issued for personal protection. Effects and articles used for their clothing or feeding shall likewise remain in their possession, even if such effects and articles belong to their regulation military equipment. At no time should prisoners of war be without identity documents. The Detaining Power shall supply such documents to prisoners of war who possess none. Badges of rank and nationality, decorations and articles having above all a personal or sentimental value may not be taken from prisoners of war. Sums of money carried by prisoners of war may not be taken away from them except by order of an officer, and after the amount and particulars of the owner have been recorded in a special register and an itemized receipt has been given, legibly inscribed with the name, rank and unit of the person issuing the said receipt. Sums in the currency of the Detaining Power, or which are changed into such currency at the prisoner's request, shall be placed to the credit of the prisoner's account as provided in Article 64. The Detaining Power may withdraw articles of value from prisoners of war only for reasons of security; when such articles are withdrawn, the procedure laid down for sums of money impounded shall apply. Such objects, likewise sums taken away in any currency other than that of the Detaining Power and the conversion of which has not been asked for by the owners, shall be kept in the custody of the Detaining Power and shall be returned in their initial shape to prisoners of war at the end of their captivity.

Article 19 – Prisoners of war shall be evacuated, as soon as possible after their capture, to camps situated in an area far enough from the combat zone for them to be out of danger. Only those prisoners of war who, owing to wounds or sickness, would run greater risks by being evacuated than by remaining where they are, may be temporarily kept back in a danger zone. Prisoners of war shall not be unnecessarily exposed to danger while awaiting evacuation from a fighting zone."

Department of Defense Directive (DoDD) 2310.1, DoD Program for Enemy Prisoners of War (EPOW) and Other Detainees, 18 August 1994, Paragraph 3.3, requires the application of appropriate legal status, transfer and release authority and authorization. Paragraph 3.4 directs the handing over of detainees to Military Police and provides for intelligence collection. Paragraph 4.4 assigns responsibility for treatment, classification, administrative processing, and custody for detainees. The specific language in the directive follows:

"3.3 Captured or detained personnel shall be accorded an appropriate legal status under international law. Persons captured or detained may be transferred to or from the care, custody, and control of the U.S. Military Services only on approval of the Assistant Secretary of Defense for International Security Affairs (ASD(ISA)) and as authorized by the Geneva Conventions

Relative to the Treatment of Prisoners of War and for the Protection of Civilian Persons in Time of War (references (d) and (e)).

3.4 Persons captured or detained by the U.S. Military Services shall normally be handed over for safeguarding to U.S. Army Military Police, or to detainee collecting points or other holding facilities and installations operated by U.S. Army Military Police as soon as practical. Detainees may be interviewed for intelligence collection purposes at facilities and installations operated by U.S. Army Military Police."

"4.4. The Commanders of the Unified Combatant Commands shall:

4.4.2. Provide for the proper treatment, classification, administrative processing, and custody of those persons captured or detained by the Military Services under their command and control. "Department of Defense Directive (DoDD) 2310.1, DoD Program for Enemy Prisoners of War (EPOW) and Other Detainees, 18 August 1994, Paragraph 1.1, reissues responsibility, specifically assigning the Army as Executive Agent for the DoD Program for Enemy Prisoners of War (EPOW) and Other Detainees. The specific language in the directive follows:

"1.1. Reissues reference (a) to update policy and responsibilities within the Department of Defense for a program to ensure implementation of the international law of war, both customary and codified, about EPOW, to include the enemy sick or wounded, retained personnel, civilian internees (CIs), and other detained personnel (detainees). Detainees include, but are not limited to, those persons held during operations other than war."

Under Secretary of Defense Memorandum, SUBJECT: Responsibility for Detainees in Association with the Global War on Terrorism, 17 January 2002, assigns the Assistant Secretary of Defense for Special Operations and Low Intensity Conflict (ASD(SO/LIC)) responsibility for DoD policies and plans related to persons detained in the Global War on Terrorism. The specific language in the memorandum follows:

"Effective immediately, ASD(SO/LIC) assumes responsibility for overall development, coordination, approval and promulgation of major DoD policies and plans related to persons detained in association with the Global War on Terrorism. This includes development, coordination, approval, and promulgation of major DoD policies, and new courses of action with DoD Components and other Federal Agencies as necessary.

DoD Directive 2310.1 will be adjusted to reflect this decision."

Army Regulation (AR) 25-30, The Army Publishing Program, 16 March 2004, Glossary, defines the term "Army regulation." And field manual The specific language in the regulation follows:

"Army regulation

A directive that sets forth missions, responsibilities, and policies, delegates authority, sets objectives, and prescribes mandated procedures to ensure uniform compliance with those policies. Mandated procedures in Army regulations are required and authoritative instructions that contain the detail needed to make sure basic policies are carried out uniformly throughout the Army. These mandated procedures also ensure uniform implementation of public law, policy

guidance, and instructions from higher headquarters or other Government agencies such as the JCP, OMB, or Department of Defense."

"Field manual.

A DA publication that contains doctrine and training principles with supporting tactics, techniques, and/or procedures and describes how the Army and its organizations function in terms of missions, organizations, personnel, and equipment. FMs implement ratified international standardization agreements. FMs may also contain informational or reference material relative to military operations and training and may be used to publish selected alliance doctrinal publications that are not readily integrated into other doctrinal literature."

AR 190-8, Enemy Prisoners of War, Retained Personnel, Civilian Internees and Other Detainees, 1 October 1997, Chapter 1, paragraph 1-1, subparagraphs a and b, implement DoDD 2310.1 and incorporates Army Regulation 190-8 and 190-57 and SECNAV Instruction 3461.3, and Air Force Joint Instruction 31-304. It establishes policies and planning guidance for the treatment, care, accountability, legal status, and administrative procedures for Enemy Prisoners of War, Civilian Internees, Retained Persons, and Other Detainees and implements international law for all military operations. The specific language in the regulation follows:

"Summary. This regulation implements Department Of Defense Directive 2310.1 and establishes policies and planning guidance for the treatment, care, accountability, legal status, and administrative procedures for Enemy Prisoners of War, Civilian Internees, Retained Persons, and Other Detainees. This regulation is a consolidation of Army Regulation 190-8 and Army Regulation 190-57 and incorporates SECNAV Instruction 3461.3 and Air Force Joint Instruction 31-304. Policy and procedures established herein apply to the services and their capabilities to the extent that they are resourced and organized for enemy prisoner of war operations.

Applicability. This is a multi-service regulation. It applies to the Army, Navy, Air Force and Marine Corps and to their Reserve components when lawfully ordered to active duty under the provisions of Title 10 United States Code.

"a. This regulation provides policy, procedures, and responsibilities for the administration, treatment, employment, and compensation of enemy prisoners of war (EPW), retained personnel (RP), civilian internees (CI) and other detainees (OD) in the custody of U.S. Armed Forces. This regulation also establishes procedures for transfer of custody from the United States to another detaining power.

b. This regulation implements international law, both customary and codified, relating to EPW, RP, CI, and ODs, which includes those persons, held during military operations other than war. The principal treaties relevant to this regulation are:

(1) The 1949 Geneva Convention Relative to the Amelioration of the Condition of the Wounded and Sick in Armed Forces in the Field (GWS).

(2) The 1949 Geneva Convention for the Amelioration of the Condition of Wounded, Sick and Shipwrecked Members of Armed Forces at Sea (GWS SEA).

(3) The 1949 Geneva Convention Relative to the Treatment of Prisoners of War (GPW).

(4) The 1949 Geneva Convention Relative to the Protection of Civilian Persons in Time of War (GC), and in the event of conflicts or discrepancies between this regulation and the Geneva Conventions, the provisions of the Geneva Conventions take precedence."

Field Manual (FM) 3-19.1, Military Police Operations, 31 January 2002, Chapter 4, paragraphs 4-42 to 4-45, describe the role of MP units in detainee operations. The specific language in the field manual follows:

"4-42. The Army is the Department of Defense's (DOD's) executive agent for all EPW/CI operations. Additionally, the Army is DOD's executive agent for longterm confinement of US military prisoners. Within the Army and through the combatant commander, the MP are tasked with coordinating shelter, protection, accountability, and sustainment for EPWs/CIs. The I/R function addresses MP roles when dealing with EPWs/CIs, dislocated civilians, and US military prisoners.

4-43. The I/R function is of humane as well as tactical importance. In any conflict involving US forces, safe and humane treatment of EPWs/CIs is required by international law. Military actions on the modern battlefield will result in many EPWs/CIs. Entire units of enemy forces, separated and disorganized by the shock of intensive combat, may be captured. This can place a tremendous challenge on tactical forces and can significantly reduce the capturing unit's combat effectiveness. The MP support the battlefield commander by relieving him of the problem of handling EPWs/CIs with combat forces. The MP perform their I/R function of collecting, evacuating, and securing EPWs throughout the AO. In this process, the MP coordinate with MI to collect information that may be used in current or future operations.

4-44. Although the CS MP unit initially handles EPWs/CIs, modular MP (I/R) battalions with assigned MP guard companies and supporting MWD teams are equipped and trained to handle this mission for the long term. A properly configured modular MP (I/R) battalion can support, safeguard, account for, guard, and provide humane treatment for up to 4,000 EPWs/CIs; 8,000 dislocated civilians; or 1,500 US military prisoners.

EPW/CI HANDLING

4-45. The MP are tasked with collecting EPWs/CIs from combat units as far forward as possible. The MP operate collection points and holding areas to temporarily secure EPWs/CIs until they can be evacuated to the next higher echelon's holding area. The MP escort-guard company assigned to the MP brigade (I/R) evacuate the EPWs/CIs from the corps's holding area to the COMMZ's internment facilities. The MP safeguard and maintain accountability, protect, and provide humane treatment for all personnel under their care."

FM 3-19.4, Military Police Leaders' Handbook, 2 August 2002, Preface, addresses detainee operations doctrine at the platoon level. The specific language in the field manual follows:

"This field manual (FM) addresses military police (MP) maneuver and mobility support (MMS), area security (AS), internment and resettlement (I/R), law and order (L&O), and police intelligence operations (PIO) across the full spectrum of Army operations. Although this manual includes a discussion of corps and division MP elements, it primarily focuses on the principles of platoon operations and the tactics, techniques, and procedures (TTP) the platoon uses to accomplish its mission."

FM 3-19.40, Military Police Internment/Resettlement Operations, 1 August 2001, Preface, establishes this FM as the doctrinal foundation for detainee operations. Chapter 2, paragraph 2-1, provides explains the role of the MP battalion commander. Chapter 3, paragraphs 3-1 to 3-3, 3-5, and 3-6, describes the basic requirements for the handling, securing, and accounting for EPWs and CIs; paragraphs 3-14 to 3-17 describe the procedures for handling property and tagging EPWs and CIs. Chapter 4 describes detailed administrative procedures for enemy prisoners of war (EPWs), including evacuation, receiving, processing, personnel files, internment serial number (ISN) issuance, information flow, facility assignment, classification, control and discipline, transfer between facilities, host nation or allied forces, and repatriation; the introduction outlines this content. Chapter 5 describes procedures for civilian internees (CIs), including specifying who is a CI, general protection requirements, authorization to intern, administrative responsibilities, receiving, processing, flow of information, security, control and discipline; the introduction explains the difference between CIs and EPWs. The specific language in the field manual follows. The specific language in the field manual follows:

"Field Manual (FM) 3-19.40 depicts the doctrinal foundation, principles, and processes that MP will employ when dealing with enemy prisoners of war (EPWs), civilian internees (CIs), US military prisoner operations, and MP support to civil-military operations (populace and resource control [PRC], humanitarian assistance [HA], and emergency services [ES])."

"2-1. An MP battalion commander tasked with operating an I/R facility is also the facility commander. As such, he is responsible for the safety and well-being of all personnel housed within the facility. Since an MP unit may be tasked to handle different categories of personnel (EPW, CI, OD, refugee, and US military prisoner), the commander, the cadre, and support personnel must be aware of the requirements for each category.

3-1. The MP units accept captives from capturing units as far forward as possible, and captives are held in CPs and CHAs until they are removed from the battlefield. Normally, CPs are operated in the division AO and CHAs are operated in the corps AO; but they can be operated anywhere they are needed. The CPs and CHAs sustain and safeguard captives and ensure a minimum level of field processing and accountability. Wounded and sick captives receive medical treatment, and captives who require lifesaving medical attention are evacuated to the nearest medical facility.

3-2. The MP establishes listening posts (LPs), observation posts (OPs), guard posts, and fighting positions to protect captives and prevent their escape. Captured soldiers are trained to believe that escape from captivity is their duty; therefore, they must be closely guarded. Consider the morale and physical condition of captives when determining the number of guards needed. Guards must be prepared to use and maintain firm control and security.

3-3. The MP work closely with military intelligence (MI) interrogation teams at CPs and CHAs to determine if captives, their equipment, and their weapons have intelligence value. This process is accelerated when MI interrogation teams can observe captives during arrival and processing, and interrogators can also be used as interpreters during this phase. Before a captive is interviewed by MI personnel, he must have a Department of Defense (DD) Form 2745 (Figure 3-1) attached to him and be accounted for on DD Form 2708.

3-5. Processing begins when US forces capture or detain an individual. The processing is accomplished in the CZ for security, control, intelligence, and the welfare of captives in evacuation channels. This is referred to as *field processing*. The capturing unit begins field processing by using the Five Ss and T procedure (search, segregate, silence, speed,

safeguard, and tag). At the CP or the CHA, MP continue processing with the principles of STRESS (search, tag, report, evacuate, segregate, and safeguard).

3-6. After receiving a captive from a capturing unit, MP are responsible for safeguarding and accounting for the captive at each stage of his removal from the battlefield. The processing procedure begins upon capture and continues until the captive reaches the I/R facility and is released. The process of identifying and tagging a captive helps US forces control and account for him as they move rearward from the battlefield. Before a captive is interned, repatriated, or released, MP at the I/R facility must provide full-scale processing.

3-14. Property Accountability. When seizing property from a captive—

- Bundle it or place it in a bag to keep it intact and separate from other captives' possessions.
- Prepare DA Form 4137 for confiscated and impounded property.
- Prepare a receipt for currency and negotiable instruments to be signed by the captive and the receiver. Use cash collection vouchers so that the value can be credited to each captive's account. List currency and negotiable instruments on the captive's personal-property list, but treat them as impounded property.
- Keep the original receipt with the property during evacuation. Give the captive a copy of the receipt, and tell him to keep it to expedite the return of his property.
- Have MI sign for property on DA Form 4137 and for captives on DD Form 2708.
- Return confiscated property to supply after it is cleared by MI teams. Items kept by MI because of intelligence value are forwarded through MI channels.
- Evacuate retained items with the captive when he moves to the next level of internment.
- Maintain controlled access to confiscated and impounded property.

3-15. Tag each captive with a DD Form 2745. The MP at CPs and CHAs check each tag for the—

- Date and time of capture.
- Capturing unit.
- Place of capture.
- Circumstances of the capture.

The remaining information on the tag is included as it becomes available.

3-16. A DD Form 2745 is a perforated, three-part form that is individually serial-numbered. It is constructed of durable, waterproof, tear-resistant material with reinforced eyeholes on Parts A and C. Part A is attached to the captive with wire or string, Part B is maintained by the capturing unit for their records, and Part C is attached to confiscated property so that the owner can be identified later.

3-17. The MP at division CPs ensure that a DD Form 2745 is placed on each captive who arrives at the CP without one. They may direct the capturing unit to complete a capture tag before accepting the prisoner into the CP. The MP—

- Make a statement on the tag if the captive arrived without it.
- Instruct the captive not to remove or alter the tag.
- Annotate the tag's serial number and the captive's name on a locally developed manifest."

Chapter 4, Introduction – "The MP are responsible for evacuating EPWs from division CPs to CHAs and then to internment facilities (normally located in the COMMZ). This chapter

addresses procedures for properly handling, processing, and safeguarding EPWs. The procedures outlined in this chapter are also applicable to RPs.

Chapter 5, Introduction – "A CI internment facility runs parallel to an EPW internment facility, with some differences.

A CI—

- Is protected under the provisions of the GC.
- Does not meet the criteria for classification as an EPW or an RP.
- Is considered a security risk.
- Needs protection because he committed an offense against the detaining power (insurgents, criminals, or other persons)."

FM 34-52, Intelligence Interrogation, 28 September 1992, Preface, establishes this FM as the doctrinal foundation for interrogations of detainees. The specific language in the field manual follows:

"This manual provides doctrinal guidance, techniques, and procedures governing employment of interrogators as human intelligence (HUMINT) collection assets in support of the commander's intelligence needs. It outlines the interrogator's role within the intelligence collection effort and the supported unit's day-to-day operations.

This manual is intended for use by interrogators as well as commanders, staff officers, and military intelligence (MI) personnel charged with the responsibility of the interrogation collection effort."

ARTEP 19-546-MTP, Mission Training Plan for the Headquarters and Headquarters Company Military Police Battalion (Internment/Resettlement), 10 April 1999, Chapter 1, paragraph 1-4, subparagraph a, outlines training doctrine for I/R battalions. The specific language in the ARTEP follows:

"1-4. Mission and Tasks.

a. The battalion's critical mission is to provide command, staff planning, administration, and logistical support for the operation of an Internment/Resettlement facility for either Enemy Prisoner of War/Civilian Internees (EPW/CI), or US Military Prisoners. It also provides direct supervision of battalion functions: Personnel, Medical, Supply, and Food Services. This MTP is composed of major activities that the unit must execute to accomplish the mission."

k. **Finding 11:**

(1) Finding: Shortfalls in both the Military Police and Military Intelligence organizational structures resulted in the tactical unit commanders adjusting their tactics, techniques, and procedures to conduct detainee operations.

(2) Standard: Field Manual (FM) 3-19.1, Military Police Operations, 31 January 2002, Chapter 7, paragraph 7-9, requires corps augmentation for sustained operations and for special operations such as dealing with dislocated civilians, and refugee internment or resettlement. Paragraphs 7-13, 7-14, 7-17, 7-21, and paragraph 7-26 discusses the employment of the different division Military Police companies, by the type of division to which they are assigned. The specific language in the field manual follows:

"7-9. In the division (where flexible support of an austere force is crucial), the division PM must have a clear understanding of situational awareness. To obtain current information for projecting MP needs in the division area, he must be mobile and be able to conduct split-cell operations. The assets available to the PM include the division MP company and at least one corps MP company. Corps augmentation is required for sustained operations and for special operations such as river crossings, dealing with dislocated civilians, and refugee internment or resettlement. The division PM coordinates with the corps PM and the MP brigade or CID commanders for— • Evacuating and guarding EPWs/CIs from division to corps."

"7-13. The Army of Excellence (AOE) heavy division MP company has six platoons. Three platoons provide support to each maneuver brigade and are designated as DS. The other three platoons are designated as GS platoons. One MP platoon provides security for the division main CP; one provides security for the division's EPW central collection point; and one performs other MP operations within the division rear.

7-14. The GS MP platoons' AOs are configured based on METT-TC and the availability of MP augmentation from the corps. The DS MP platoons' AOs coincide with the supported maneuver brigade's boundary. Each platoon headquarters locates within its brigade's support area or any other area where it can best provide and receive support. To accomplish its mission, each DS platoon requires a minimum of two squads, each with three teams. One squad operates the EPW/CI collection point. The other squads perform MMS and AS operations. All MP platoons are capable of performing all five MP functions. However, performance of these functions is prioritized based on METT-TC and the division commander's concept of operations. The division PM, the company commander, and METT-TC dictate how these platoons should be tasked-organized to accomplish the mission."

"7-17. The company has three GS platoons to support the division. No platoons are provided to the maneuver brigade. One platoon is normally located in the vicinity of the division main CP so that its resources can help support CP security. Another platoon locates in the DSA and operates the division EPW/CI collection point. The last platoon has an AO configured according to METT-TC and the commander's priority of MP missions. Each GS MP platoon has a headquarters and three squads, each with two teams. The PM section is located in the vicinity of the division main CP. The exact location is based on the current operational status and on METT-TC.

"7-21. The nature of airborne operations makes the capture of EPWs likely. Therefore, during the first stage of the assault phase, the priority of MP support is given to EPW operations. After assembling the DZ or LZ, the MP collect EPWs captured during the assault. Combat elements are relieved of EPWs as far forward as possible. In airborne operations, EPWs are held for later movement to a central collection point. During the first stage of the assault, the MP perform limited straggler and refugee control and undertake AS operations, when possible.

"7-26. When possible, habitually aligned platoons remain with their brigades, and corps assets perform GS missions. However, when no corps assets are available and two division platoons are employed as stated above, the two remaining platoons conduct division EPW collection-point operations and other MP functions based on METT-TC. Normally, the EPW platoon and the MP company headquarters collocate in the DSA. As required (and based on METT-TC), airflow planning includes EPW/CI evacuation from the AATF/FOB collection point back to the DSA. The PM section operates from the division rear CP to facilitate I/R operations and to coordinate MMS and AS with key logistical staff. Due to potentially extreme distances on

the air assault battlefield, the DPM normally locates with the division main CP to serve as a key G3 battle-staff member and to coordinate PIO with the G2."

FM, 3-19.40, Military Police Internment/Resettlement Operations, 1 August 2001, Chapter 3, addresses the responsibility of division Military Police (MP) units to operate collecting points and to assist maneuver units as they move through the battlefield and perform their mission. Paragraph 3-1 assigns MP units the responsibility to accept captives from capturing units as far forward as possible, but allowing them to operate anywhere they are needed. Paragraph 3-3 describes how MP personnel work closely with the Military Intelligence (MI) interrogators to determine if detainees and their possessions have any intelligence value. Paragraph 3-5 outlines the beginning of detainee processing when U.S. Armed Forces detain an individual in the combat zone. Paragraph 3-64 provides information to facilitate collecting enemy tactical information and how MI may collocate interrogation teams at collecting points and Corps Holding Area to collect intelligence information. The specific language in the field manual follows:

"A large number of captives on the battlefield hampers maneuver units as they move to engage and destroy an enemy. To assist maneuver units in performing their mission— • Division MP units operate CPs in the division AO. • Corps MP units operate holding areas in the corps AO."

"3-1. The MP units accept captives from capturing units as far forward as possible, and captives are held in CPs and CHAs until they are removed from the battlefield. Normally, CPs are operated in the division AO and CHAs are operated in the corps AO; but they can be operated anywhere they are needed. The CPs and CHAs sustain and safeguard captives and ensure a minimum level of field processing and accountability. Wounded and sick captives receive medical treatment, and captives who require lifesaving medical attention are evacuated to the nearest medical facility."

"3-3. The MP work closely with military intelligence (MI) interrogation teams at CPs and CHAs to determine if captives, their equipment, and their weapons have intelligence value. This process is accelerated when MI interrogation teams can observe captives during arrival and processing, and interrogators can also be used as interpreters during this phase. Before a captive is interviewed by MI personnel, he must have a Department of Defense (DD) Form 2745 (Figure 3-1) attached to him and be accounted for on DD Form 2708."

"3-5. Processing begins when US forces capture or detain an individual. The processing is accomplished in the CZ for security, control, intelligence, and the welfare of captives in evacuation channels. This is referred to as field processing. The capturing unit begins field processing by using the Five Ss and T procedure (search, segregate, silence, speed, safeguard, and tag). At the CP or the CHA, MP continue processing with the principles of STRESS (search, tag, report, evacuate, segregate, and safeguard)."

"3-64. To facilitate collecting enemy tactical information, MI may collocate interrogation teams at CPs and CHAs. This provides MI with direct access to captives and their equipment and documents. Coordination is made between MP and MI to establish operating procedures that include accountability. An interrogation area is established away from the receiving/processing line so that MI personnel can interrogate captives and examine their equipment and documents. If a captive or his equipment or documents are removed from the receiving/processing line, account for them on DD Form 2708 and DA Form 4137."

FM, 34-52, Intelligence Interrogation, 28 September 1992, Chapter 1, definition of Interrogation, pages 1-6 and 1-7, Objective, pages 1-7, discuss the interrogator should not concentrate on the objective to the extent he overlooks or fails to recognize and exploit other valuable information extracted from the source. Chapter 2, page 2-1, Composition and Structure, discusses that the interrogation architecture is a seamless system that supports operations from brigade to theater level. Page 2-2, Interrogation below division, addresses the first interrogation could take place at brigade level to receive tactical information that will provide immediate value to the unit on the ground. Page 2-3, Division interrogation assets, provides an overview of the capabilities a division Military Intelligence battalion provides to a division. Page 2-4, Interrogation Teams, provides the composition of an interrogation team and is normally employed as part of the MI company teams. Page 2-12, Interrogation at Brigade and Below, describes that an MI battalion interrogator can be attached temporarily to the committed battalion to assist in exploiting information immediately from the enemy prisoner of war (EPW). Page 2-22, Theater Interrogation Facility, describe the purpose of the Theater Interrogation Facility and that it is staffed by U.S. Army interrogators, with support from Air Force, Navy, Marine Corps, and other U.S. national agencies as required. Page 3-1, provides the criteria for selecting personnel to be interrogated. Page 3-2, Screening, explains the screening to select a source to interrogate. Page 3-2, Prepare to conduct screenings, describe the coordination and roles between the screeners and MP holding area guards. Page 3-2, Document Screening, outlines when examining documents, the screener should identify topics on which EPWs and detainees have pertinent information that may contain indications of pertinent knowledge and potential cooperation. Page 3-2, Personnel Screening, recommends if time permits, that screeners should question holding area personnel about the EPWs and detainees who might identify sources or answer the supported commander's priority intelligence requirements (PIR) and intelligence requirements (IR). Page 3-29, Interrogation with an Interpreter, provides what needs to take place before, during, and after an interrogation. Page 3-30 Conduct the Interrogation, outlines the steps the interrogators need to take when an interpreter does not follow the guidance of the interrogator during an interrogation. The specific language in the field manual follows:

Page 1-6. "Definition of Interrogation. Interrogation is the process of questioning a source to obtain the maximum amount of usable information. The goal of any interrogation is to obtain reliable information in a lawful manner, in a minimum amount of time, and satisfy intelligence requirements of any echelon of command. Sources may be - civilian internees, insurgents, EPWs, defectors, refugees, displaced persons, agents or suspected agents, other non-US personnel. A good interrogation produces needed information which is timely, complete, clear, and accurate. An interrogation involved the interaction of two personalities - the source and the interrogator."

Page 1-7. "Objective. Each interrogation must be conducted for a definite purpose. The interrogator must keep this purpose firmly in mind as he proceeds to obtain usable information to satisfy the assigned requirement, and thus contribute to the success of the unit's mission.... In either case, the interrogator must use the objective as a basis for planning and conducting the interrogation. He should attempt to prevent the source from becoming aware of the true objective of the interrogation. The interrogator should not concentrate on the objective to the extent he overlooks or fails to recognize and exploit other valuable information extracted from the source."

Page 2-1. "Composition and Structure. The interrogation architecture (interrogators and interrogation units) is a seamless system that supports operations from brigade to theater level. The dynamic warfighting doctrine requires interrogation units be highly mobile and have

automation and communication equipment to report information to the supported commander. The MI commander must ensure interrogators have the necessary equipment to accomplish their wartime mission. The MI commander retains overall responsibility for interrogators assigned to his unit. The manner in which these interrogators are controlled depends on how the MI unit is task organized for combat."

Page 2-2, "Interrogation Below Division. The first interrogation could take place at brigade. Interrogation teams are attached temporarily to brigades in enemy contact when determined appropriate by the division G2. These teams come from the interrogation section of the parent division. Interrogation personnel are organic to separate brigades and armored cavalry regiments (ACRs). Interrogation at brigade level is strictly tactical and deals with information of immediate value.

Interrogation personnel in DS to brigade will be collocated or immediately adjacent to the division forward EPW collecting point in the brigade support area (BSA). For MI units to receive S2 support, the collecting point and interrogation site will be collocated and accessible to the command post (CP)."

Page 2-3, "Division Interrogation Assets. An MI battalion is organic to each division. It provides combat intelligence, EW, and OPSEC support to light or heavy infantry and airborne or air assault division. The MI battalion provides special support the G2 needs to produce combat intelligence. Interrogation personnel organic to the MI battalions compose the interrogation support element."

Page 2-4, "Interrogation Teams. Each interrogation team consists of a team leader (warrant officer), NCO assistant team leader, and three team members. Teams are normally employed as part of the MI company teams which provide IEW support to the brigades."

Page 2-12. "Interrogation at Brigade and Below. Interrogators are not usually attached below brigade level unless the combat situation requires limited tactical interrogation at battalion or lower. In this event, skilled interrogators from the MI battalion will be attached temporarily to committed battalions. They will assist in exploiting EPW immediately upon capture to extract information needed in support of the capturing unit.

Interrogations at battalion or lower are brief and concerned only with information bearing directly on the combat mission of the capturing unit. The following are examples of circumstance warranting an interrogation:

- A unit or landing force assigned an independent mission in which the S2 is primarily responsible for collecting information necessary to fulfill the unit's mission. Immediate tactical intelligence is necessary for mission accomplishment.
- There is a definite need for interrogation at the lower level to permit rapid reaction based on information obtained.
- It is advantageous to have an EPW point out enemy defense and installation from observation points in forward areas."

Page 2-22. "Theater Interrogation Facility. The EAC interrogation facility will normally be designated as the TIF. A TIF is staffed by US Army interrogators and analysts, with support from Air Force, Navy, Marine Corps, and other US national agencies as required. In a

multinational operation, a combined interrogation facility may be established with allied interrogators augmentation. In addition to conventional theater Army operations, a TIF may be established to support a joint or unified command to meet theater requirements during crisis or contingency deployments.

MI battalion companies, MI brigade (EAC) provide US Army interrogation support to the EAC TIF. The mission of the TIF is to-

- Interrogate PWs, high-level political and military personnel, civilian internees, defectors, refugees, and displace persons."

"A TIF is organized into a headquarters section, operations section, and two interrogation and DOCEX sections. It will normally have an attached TSA section from Operations Group, and a liaison team from the Joint Captured Materiel Exploitation Center (JCMEC). The JCMEC liaison team assists in exploiting sources who have knowledge of captured enemy weapons and equipment.

- Provost marshal for location of theater EPW camps, and for procedures to be followed by interrogators and MP for processing, interrogating, and internment."

Page 3-1. "Interrogation Process. Criteria for selecting personnel to be interrogated vary with the - commander's collection requirements. Time limitations. Number and types of potential sources available. Exact circumstance surrounding the employment of US Forces. In this regard, source selection is important in conducting interrogation at tactical echelons of command because of the proximity to enemy elements, number and conditions of detainees, and time restrictions."

Page 3-2. "Screening. Screening is the selection of sources for interrogation. It must be conducted at every echelon to-Determine source cooperativeness and knowledgeability. Determine which sources can best satisfy the commander's PIR and IR in a timely manner."

Page 3-2. "Prepare to Conduct Screenings. Screeners coordinate MP holding area guards on their role in the screening process. The guards are told where the screening will take place, how EPWs, and detainees are to be brought there from the holding area, and what types of behavior on their part will facilitate the screening."

Page 3-2. "Document Screening. If time permits, screeners should go to the holding area and examine all available documents pertaining to the EPWs and detainees. They should look for signs that certain EPWs and detainees are willing, or can be induced, to cooperate with the interrogators. Previous screening and interrogation reports and EPW personnel records are important."

Page 3-2. "Personnel Screening. If time permits, screeners should question holding area personnel about the EPWs and detainees. Since these personnel are in almost constant contact with the EPWs and detainees, their descriptions of specific ones can help identify sources who might answer the supported commander's PIR and IR. Screeners should identify and note those EPWs and detainees whose appearance and behavior indicate they are willing to cooperate immediately or are unlikely to cooperate ever."

Page 3-29. "Interrogation With an Interpreter. Interrogation through an interpreter is time consuming because the interpreter must repeat everything said by the interrogator and source.

The interrogator must brief the interpreter before the interrogation can begin. An interrogation with an interpreter will go through all five phases of the interrogation process. After the interrogation is over, the interrogator will evaluate the interpreter."

Page 3-30. "Conduct the Interrogation. During the interrogation, the interrogator corrects the interpreter if he violates any standards on which he was briefed. For example, if the interpreter injects his own ideas into the interrogation, he must be corrected.

"Corrections should be made in a low-key manner. At no time should the interrogator rebuke his interpreter sternly or loudly while they are with the source. The interrogator should never argue with the interpreter in the presence of the source. If a major correction must be made, the interrogator and the interpreter should leave the interrogation site temporarily, and only when necessary."

I. Finding 12:

(1) Finding: There was no Theater Detainee Reporting Center (TDRC) acting as the central, theater-level agency responsible for detainee accountability, resulting in a lack of detainee personnel and data management.

(2) Standard: Standard of treatment for detainees in OPERATION ENDURING FREEDOM (OEF): Chairman, Joint Chiefs of Staff (CJCS) message dated 211933Z JAN 02 states that members of the Taliban militia and members of Al Qaida under the control of US Forces would be treated humanely and, to the extent appropriate and consistent with military necessity, in a manner consistent with the principles of the Geneva Conventions of 1949. The DAIG has therefore used the provisions of the Geneva Conventions as a benchmark against which to measure the treatment provided to detainees by U.S. Forces to determine if detainees were treated humanely. The use of these standards as benchmarks does not state or imply a position for the United States or U.S. Army on the legal status of its operations in OEF.

CJCS Message dated 211933Z JAN 02, provides the determination regarding the humane treatment of Al Qaida and Taliban detainees. Convention Relative to the Treatment of Prisoners of War of August 12, 1949 (GPW) is the international treaty that governs the treatment of prisoners of war; and Geneva Convention Relative to the Protection of Civilian Persons in Time of War (GC), August 12, 1949 is the international treaty that governs the treatment of civilian persons in time of war.

As the guidance did not define "humane treatment" but did state that the US would treat members of the Taliban militia and Al Qaida in a manner consistent with the Geneva Conventions, the DAIG determined that it would use Common Article 3 of the GCs as its floor measure of humane treatment, but would also include provisions of the Geneva Convention on the Treatment of Prisoners of War (GPW) and Geneva Convention Relative to the Protection of Civilian Persons in Time of War (GC) as other relevant indicia of "humane treatment." The use of this standard does not state or imply a position for the United States or U.S. Army on the legal status of its operations in OEF.

Standard of treatment for detainees in OPERATION IRAQI FREEDOM (OIF): OIF was an international armed conflict and therefore the provisions of the Geneva Conventions applied. Additionally, the United States was an occupying power and has acted in accordance with the obligations of an occupying power described in the Hague Convention No. IV Respecting the Laws and Customs of War on Land (H.IV), Oct. 18, 1907, including, but not limited to Articles

43-46 and 50; Geneva Convention Relative to the Treatment of Prisoners of War of August 12, 1949 (GPW), Geneva Convention Relative to the Protection of Civilian Persons in Time of War (GC), August 12, 1949. The GC supplements H.IV, providing the general standard of treatment at Article 27 and specific standards in subsequent Articles.

The minimum treatment provided by Common Article 3 of the Geneva Conventions is: (1) No adverse distinction based upon race, religion, sex, etc.; (2) No violence to life or person; (3) No taking hostages; (4) No degrading treatment; (5) No passing of sentences in absence of fair trial, and; (6) The wounded and sick must be cared for.

The specific language in the CJCS Message for OEF and the GPW/GC and H.IV follows:

CJCS Message dated 211933Z JAN 02, "Paragraph 3. The combatant commanders shall, in detaining Al Qaida and Taliban individuals under the control of the Department of Defense, treat them humanely and, to the extent appropriate and consistent with military necessity, in a manner consistent with the principles of the Geneva Conventions of 1949."

GPW/GC, Article 3 (Common Article 3) – "In the case of armed conflict not of an international character occurring in the territory of one of the High Contracting Parties, each party to the conflict shall be bound to apply, as a minimum, the following provisions:

1. Persons taking no active part in the hostilities, including members of armed forces who have laid down their arms and those placed hors de combat by sickness, wounds, detention, or any other cause, shall in all circumstances be treated humanely, without any adverse distinction founded on race, color, religion or faith, sex, birth or wealth, or any other similar criteria.

To this end the following acts are and shall remain prohibited at any time and in any place whatsoever with respect to the above-mentioned persons:

(a) Violence to life and person, in particular murder of all kinds, mutilation, cruel treatment and torture;
 (b) Taking of hostages;
 (c) Outrages upon personal dignity, in particular, humiliating and degrading treatment;
 (d) The passing of sentences and the carrying out of executions without previous judgment pronounced by a regularly constituted court affording all the judicial guarantees which are recognized as indispensable by civilized peoples.

2. The wounded and sick shall be collected and cared for. An impartial humanitarian body, such as the International Committee of the Red Cross, may offer its services to the Parties to the conflict. The Parties to the conflict should further endeavour to bring into force, by means of special agreements, all or part of the other provisions of the present Convention. The application of the preceding provisions shall not affect the legal status of the Parties to the conflict."

The following specific provisions of GPW and GC apply:

"Article 18 – All effects and articles of personal use, except arms, horses, military equipment and military documents, shall remain in the possession of prisoners of war, likewise their metal helmets and gas masks and like articles issued for personal protection. Effects and

articles used for their clothing or feeding shall likewise remain in their possession, even if such effects and articles belong to their regulation military equipment. At no time should prisoners of war be without identity documents. The Detaining Power shall supply such documents to prisoners of war who possess none. Badges of rank and nationality, decorations and articles having above all a personal or sentimental value may not be taken from prisoners of war. Sums of money carried by prisoners of war may not be taken away from them except by order of an officer, and after the amount and particulars of the owner have been recorded in a special register and an itemized receipt has been given, legibly inscribed with the name, rank and unit of the person issuing the said receipt. Sums in the currency of the Detaining Power, or which are changed into such currency at the prisoner's request, shall be placed to the credit of the prisoner's account as provided in Article 64. The Detaining Power may withdraw articles of value from prisoners of war only for reasons of security; when such articles are withdrawn, the procedure laid down for sums of money impounded shall apply. Such objects, likewise sums taken away in any currency other than that of the Detaining Power and the conversion of which has not been asked for by the owners, shall be kept in the custody of the Detaining Power and shall be returned in their initial shape to prisoners of war at the end of their captivity.

Article 19 – Prisoners of war shall be evacuated, as soon as possible after their capture, to camps situated in an area far enough from the combat zone for them to be out of danger. Only those prisoners of war who, owing to wounds or sickness, would run greater risks by being evacuated than by remaining where they are, may be temporarily kept back in a danger zone. Prisoners of war shall not be unnecessarily exposed to danger while awaiting evacuation from a fighting zone."

Department of Defense Directive (DoDD), 2310.1, DoD Program for Enemy Prisoners of War (EPOW) and Other Detainees, 18 August 1994, Paragraph 1.2, designates the Secretary of the Army as Executive Agent for detainee operations; paragraph 4.2.5 establishes information coordination requirements for the Executive Agent for detainee operations. The specific language in the directive follows:

"1.2. Designates the Secretary of the Army as the Executive Agent for the Department of Defense for the administration of the DoD EPOW Detainee Program.

"4.2.5. Provide, in coordination with the ASD(ISA), appropriate reports to the OSD, the Chairman of the Joint Chiefs of Staff, and information or reports to other U.S. Government Agencies or Components, to include the Congress of the United States, or to the International Committee of the Red Cross."

Army Regulation (AR) 190-8, Enemy Prisoners of War, Retained Personnel, Civilian Internees and Other Detainees, 1 October 1997, Chapter 1, paragraph 1-7, subparagraph b, requires specific data elements to be collected and stored by the National Prisoner of War Information Center (NPWIC, now called the National Detainee Recording Center (NDRC)). Paragraph 1-8, subparagraphs a and b, assigns the Branch Prisoner of War Information Center (Branch PWIC, now called the Theater Detainee Reporting Center (TDRC)) as the field agency for maintaining information on persons and property within an assigned theater of operations or in Continental United States (CONUS) and outlines the Branch PWIC's primary responsibilities. Chapter 2, paragraph 2-1, subparagraph a (1) (b), explains how prisoners are to be tagged. Paragraph 2-2, subparagraph b (1), requires the use of DA Form 4137 for accounting for large sums of money and property taken from captured persons. This regulation is a multi-service regulation implementing DOD Directive 2310.1 and incorporates Army Regulation 190-8 and 190-57 and SECNAV Instruction 3461.3, and Air Force Joint Instruction 31-304 and outlines

policies, procedures, and responsibilities for treatment of enemy prisoners of war (EPW), retained personnel (RP), civilian internees (CI), and other detainees (OD) and implements international law for all military operations. The specific language in the regulation follows:

1-7. b. – "Obtain and store information concerning EPW, CI and RP, and their confiscated personal property. Information will be collected and stored on each EPW, CI, and RP captured and detained by U.S. Armed Forces. This includes those EPW, RP, who were captured by the United States but are in custody of other powers and those who have been released or repatriated. EPW, CI and RP cannot be forced to reveal any information however they are required to provide their name, rank, serial number and date of birth. The Geneva Convention requires the NPWIC to collect and store the following information for EPW, RP:

- (1) Complete name.
- (2) ISN.
- (3) Rank.
- (4) Serial number.
- (5) Date of birth.
- (6) City of birth.
- (7) Country of birth.
- (8) Name and address of next of kin.
- (9) Date of capture.
- (10) Place of capture.
- (11) Capturing unit.
- (12) Circumstances of capture.
- (13) Location of confiscated personal property.
- (14) Nationality.
- (15) General statement of health.
- (16) Nation in whose armed services the individual is serving.
- (17) Name and address of a person to be notified of the individual's capture.
- (18) Address to which correspondence may be sent.
- (19) Certificates of death or duly authenticated lists of the dead.
- (20) Information showing the exact location of war graves together with particulars of the dead.
- (21) Notification of capture.
- (22) List of personal articles of value not restored upon repatriation."

1-8. a. – "The Branch PWIC functions as the field operations agency for the NPWIC. It is the central agency responsible to maintain information on all EPW, CI and RP and their personal property within an assigned theater of operations or in CONUS.

1-8. b. – The Branch PWIC serves as the theater repository for information pertaining to:

- (1) Accountability of EPW, CI, and RP and implementation of DOD policy.
- (2) Providing initial and replacement block ISN assignments to theater EPW, CI and RP processing organizations, and requests replacement ISN's from the NPWIC.
- (3) Obtaining and storing information concerning all EPW, CI and RP, in the custody of U.S. Armed Forces, those captured by U.S. Armed Forces and transferred to other powers for internment (either temporarily or permanently), those EPW and RP transferred to CONUS for internment, and EPW, CI and RP released or repatriated. Obtaining and storing information about CI kept in the custody of U.S. Armed Forces within its assigned theater of operations who are subjected to assigned residence, interned, or released."

2-1. a. (1) (b) – "All prisoners of war and retained persons will, at the time of capture, be tagged using DD Form 2745.

2-2. b. (1) – Appropriate intelligence sources will be notified when EPW and RP are found in possession of large sums of U.S. or foreign currency. A receipt DA Form 4137 will be prepared to account for all property that is taken from the EPW. Copies of DD Form 629 (Receipt for Prisoner or Detained Person) and DA Form 4137 will be maintained to establish positive accountability of the EPW and their property and can be used to substantiate proper care and treatment at a later time. DA Form 4137 will be used to account for property released before final disposition is ordered. Records of disposition of property will be evacuated with prisoners for inclusion in their personnel records."

Field Manual (FM) 3-19.40, Military Police Internment/Resettlement Operations, 1 August 2001, Chapter 3, paragraphs 3-45 and 3-54, establish the 12-hour forward collecting point and 24-hour central collecting point doctrine. The specific language in the field manual follows:

"3-45. Captives should not remain at a forward CP more than 12 hours before being escorted to the central CP.

3-54. Captives should not remain at the central CP more than 24 hours before being evacuated to the CHA."

m. Finding 13:

(1) Finding: The ongoing Military Intelligence Force Design Update is better suited to conduct simultaneous and sustained human intelligence missions in the current and future operating environment.

(2) Standard: Army Regulation (AR) 71-32, Force Development and Documentation—Consolidated Policies, 3 March 1997, Paragraph 2-1, subparagraph f, establishes the Deputy Chief of Staff for Operations and Plans (DCSOPS) responsibility for The Army Authorization Documents System-Redesign (TAADS-R) systems, which provides Army Modified Table of Organization and Equipment (MTOE) and Table of Distribution and Allowance (TDA) units with authorization documents containing the HQDA-approved organizational structure, personnel and equipment requirements and authorizations. Paragraph 2-2, subparagraph x, directs the Commander of U.S. Army Force Management Support Agency (USAFMSA) to act as executive agent for TAADS-R and review, develop, and publish MTOEs and TDAs. Paragraph 2-26, subparagraphs a-c, requires the Commander of U.S. Army Training and Doctrine Command (TRADOC) to develop and validate battlefield requirements and use the force design update process to document needed changes. TRADOC develops organizational concepts and designs. TRADOC provides USAFMSA the approved organization designs for the development of a Table of Organization and Equipment (TOE). Paragraph 4-1, subparagraphs b, c, and e, describe the TOE as the result of the combat development process and documents wartime capabilities, organizational structure, personnel and equipment. Paragraph 4-4 describes the concept for TOE review and revision. In this case the TOE revision documents a more effective organizational design. The specific language in the regulation follows:

"2-1. Deputy Chief of Staff for Operations and Plans (DCSOPS)
The DCSOPS will—

"f. Have HQDA responsibility for TAADS-R and, after appropriate HQDA coordination, will—

"(2) Develop and manage the Army force structure.

"(4) In coordination with the DCSPER and the DCSLOG publish and enforce policy and procedures to document requirements for and authorization of, organizations, personnel, and equipment.

"(6) Serve as the final HQDA approval authority for authorization documents.

"2-2. CDR, U.S. Army Force Management Support Agency (USAFMSA)
CDR, USAFMSA will—

"x. Act as executive agent for the operation of the TAADS-R and perform the following:

"(9) Perform technical review of Active Army and Reserve Component (RC) MTOE and TDA.

(10) Develop MTOEs for all Active Army and RC MTOE organizations under the GENDOC concept.

(11) Provide a foundation for manning the force, quantitatively and qualitatively, principally through detailed manpower requirements determination programs such as MARC, manpower staffing guides, organizational and manpower studies, and the MS3.

"(17) Maintain and distribute current files of all authorization documents (MTOEs and TOEs). Furnish authorization documentation data to HQDA and agencies/activities using TAADS.

"2-26. CG, U.S. Army Training and Doctrine Command (TRADOC)
In addition to the responsibilities in paragraph 2-19, the CG, TRADOC will—

a. Lead the Army in developing and validating battlefield requirements and use the force design update (FDU) process as the semiannual Army process to update organizational concepts and designs.

b. Develop organizational concepts and designs.

c. Provide USAFMSA completed unit reference sheets for FDU approved organization designs as the basis for TOE development.

"4-1. Concepts

"b. The TOE is the end product document of the Army's combat development process. It merges, in one document, the results of the requirements determination process...

"c. TOEs are the primary basis for stating Army requirements. This document heavily impacts the budget, the training base, efficiency, operational readiness, and overall management of Army resources.

"e. The TOE system is characterized by incremental TOEs that prescribe the wartime mission, capabilities, organizational structure, and minimum mission essential personnel and equipment requirements for military units. They portray the doctrinal modernization path (MODPATH) of a unit over time from the least modernized configuration to the most modernized.

"4-4. TOE review and revision

TOEs are normally revised as required to accommodate changes to doctrine, introduction of new equipment, or to incorporate more effective designs. Some TOEs are replaced by new organizations. Those TOEs that do not fall into the above categories will be reviewed not less than every three years from the date of approval."

AR 381-20, The Army Counterintelligence Program, 15 November 1993, Glossary, defines the terms counterintelligence, counterintelligence operations, and counterintelligence special agent. The term Military Occupational Specialty (MOS) refers to the type of training and skills of a Soldier in a specific specialty. In this report the DAIG Team uses the abbreviation CI to refer to Civilian Internees; the Military Intelligence mission of counterintelligence will not be abbreviated as CI except when quoted directly from Military Intelligence policy/doctrine paragraph(s) referring to counterintelligence, as in the following. The specific language in the regulation follows:

"counterintelligence

1. Information gathered and activities conducted to protect against espionage, other intelligence activities, sabotage or assassinations conducted for or on behalf of foreign powers, organizations, or persons, or international terrorist activities, but not including personnel, physical, document or communications security programs. Synonymous with foreign counterintelligence. (ICS Glossary)

2. Those activities which are concerned with identifying and counteracting the threat to security posed by foreign intelligence services or organizations, or by individuals engaged in espionage, sabotage, sedition, subversion or terrorism.

"counterintelligence operations

Activities taken to hinder the multidisciplinary activities of foreign intelligence and security services, and to cause FIS to doubt the validity of its own analysis.

"counterintelligence special agent

Soldiers holding the SSI 35E, MOS 351B or 97B, and civilian employees in the GS-0132 career field, who have successfully completed a CI [counterintelligence] officer/agent course, who are authorized USAI badges and credentials, and who are assigned to conduct CI [counterintelligence] investigations and operations. Also known as CI [counterintelligence] agent or MI agent."

Field Manual (FM) 34-60, Counterintelligence, 3 October 1995, Chapter 1, describes the Army counterintelligence mission as preventing other organizations and agencies from gathering information on Army organizations and agencies. Counterintelligence operations is a force protection factor and includes counter-human intelligence (C-HUMINT), counter-signals

intelligence (C-SIGINT), and counter-imagery intelligence (C-IMINT) functions. In this report the DAIG Team uses the abbreviation CI to refer to Civilian Internees; the Military Intelligence mission of counterintelligence will not be abbreviated as CI except when quoted directly from Military Intelligence policy/doctrine paragraph(s) referring to counterintelligence, as in the following. The specific language in the field manual follows:

"MISSION

The CI [counterintelligence] mission is authorized by Executive Order (EO) 12333, implemented by AR 381-20. The Army conducts aggressive, comprehensive, and coordinated CI [counterintelligence] activities worldwide. The purpose is to detect, identify, assess, counter, neutralize, or exploit threat intelligence collection efforts. This mission is accomplished during peacetime and all levels of conflict. Many CI [counterintelligence] functions, shown in Figure 1-1, are conducted by echelons above corps (EAC); some by echelons corps and below (ECB); and some are conducted by both. Those CI [counterintelligence] assets found at ECB respond to tactical commanders. EAC assets respond primarily to commanders of intelligence units while supporting all commanders within their theater or area of operations (AO).

"The essence of the Army's CI [counterintelligence] mission is to support force protection. By its nature, CI [counterintelligence] is a multidiscipline (C-HUMINT, C-SIGINT, and C-IMINT) function designed to degrade threat intelligence and targeting capabilities. Multidiscipline counterintelligence (MDCI) is an integral and equal part of intelligence and electronic warfare (IEW). MDCI operations support force protection through OPSEC, deception, and rear area operations across the range of military operations. For more information on IEW operations, see FM 34-1."

ST 2-22.7, Tactical Human Intelligence and Counterintelligence Operations, 11 April 2002, Paragraphs 1-1 and 1-7, describe the relationship between human intelligence (HUMINT) and counterintelligence and the function of Tactical HUMINT. Paragraph 1-10 defines the term HUMINT Collector. Additionally, the unit's counterintelligence mission is a force protection factor. In this report the DAIG Team uses the abbreviation CI to refer to Civilian Internees; the Military Intelligence mission of counterintelligence will not be abbreviated as CI except when quoted directly from Military Intelligence policy/doctrine paragraph(s) referring to counterintelligence, as in the following. The specific language in the manual follows:

"1-1. HUMINT and CI [counterintelligence] have distinctly different missions. HUMINT collectors gather information to answer intelligence and information requirements while CI [counterintelligence] personnel help protect the force from an adversary's intelligence collection efforts. HUMINT collectors and CI [counterintelligence] personnel bring unique sets of skills to any mission. At times each discipline may uncover information relating to the other's primary mission. Although HUMINT collectors and CI [counterintelligence] personnel appear to have similar functions, because the common denominator is human interaction, each discipline has its own area of expertise.

"1-7. Tactical HUMINT is the task organization of HUMINT collection assets and CI [counterintelligence] assets into combined teams to accomplish the mission of both disciplines at the tactical level (echelon corps and below). This task organization supports the force protection plan and answers the commander's intelligence requirements by employing -

- "CI [counterintelligence] agents to conduct focused identification, collection, analysis, recommendation of countermeasures, and production against FISS technical means and other adversary intelligence collection threats.
- "HUMINT collectors to conduct focused collection, analysis, and production on the adversary's composition, strength, dispositions, tactics, equipment, personnel, personalities, capabilities, and intentions.

"1-10. HUMINT collectors are personnel who, by training or in certain specific positions, are tasked with collecting information for intelligence use from people or related documents. A HUMINT source is any person who can provide information to answer collection requirements. [Unless otherwise noted in this manual, the term "HUMINT collector" refers to personnel in MOSs 351E and 97E. The term "CI [counterintelligence] collector" or "CI [counterintelligence] agent" refers to 35E, 351B, and 97B personnel.] The HUMINT and CI [counterintelligence] force is organized, trained, and equipped to provide timely and relevant answers to information requirements at each echelon. While HUMINT and CI [counterintelligence] have a different focus, in most deployment scenarios they work best in a collaborative effort."

n. Finding 14:

(1) Finding: The ongoing Military Police Force Design Update provides a force structure for internment/resettlement operations that has the flexibility and is better suited to conduct sustained detainee operations in the current and future operating environments.

(2) Standard: Army Regulation (AR) 71-32, Force Development and Documentation—Consolidated Policies, 3 March 1997, Paragraph 2-1, subparagraph f, establishes the Deputy Chief of Staff for Operations and Plans (DCSOPS) responsibility for The Army Authorization Documents System-Redesign (TAADS-R) systems, which provides Army Modified Table of Organization and Equipment (MTOE) and Table of Distribution and Allowance (TDA) units with authorization documents containing the HQDA-approved organizational structure, personnel and equipment requirements and authorizations. Paragraph 2-2, subparagraph f, requires Commander of U.S. Army Force Management Support Agency (USAFMSA) to review, evaluate, and coordinate all changes to force structure documents with effected Major Commands (MACOMs) and the U.S. Army Training and Doctrine Command (TRADOC) proponent. Paragraph 2-26, subparagraphs a-c, requires the Commander of U.S. Army Training and Doctrine Command (TRADOC) to develop and validate battlefield requirements and use the force design update process to document needed changes. TRADOC develops organizational concepts and designs. TRADOC provides USAFMSA the approved organization designs for the development of a Table of Organization and Equipment (TOE). Paragraph 4-1, subparagraphs b, c, and e, describe the TOE as the result of the combat development process and documents wartime capabilities, organizational structure, personnel and equipment. Paragraph 4-4 describes the concept for TOE review and revision. In this case the TOE revision documents a more effective organizational design. Paragraph 8-4, Table 8-1, gives the characteristics of an MTOE: a unit or organization with the ability to perform sustained Combat, Combat Support (CS), or Combat Service Support (CSS) missions; and the characteristics of a TDA: a unit or organization performing a mission at a fixed location. The Active Component (AC) units qualified to conduct internment/resettlement (I/R) operations are organized in TDAs and are not designed for deployment. Reserve Component (RC) units conducting I/R operations are organized in MTOEs for deployment. The specific language in the regulation follows:

"2-1. Deputy Chief of Staff for Operations and Plans (DCSOPS)
The DCSOPS will—

"f. Have HQDA responsibility for TAADS-R and, after appropriate HQDA coordination, will—

"(2) Develop and manage the Army force structure.

"(4) In coordination with the DCSPER and the DCSLOG publish and enforce policy and procedures to document requirements for and authorization of, organizations, personnel, and equipment.

"(6) Serve as the final HQDA approval authority for authorization documents.

"2-2. CDR, U.S. Army Force Management Support Agency (USAFMSA)
CDR, USAFMSA will—

"f. Review and evaluate all proposed TOE changes. Coordinate requests for TOE changes with the affected MACOM and proponent schools. Recommend approval to HQDA if appropriate.

"2-26. CG, U.S. Army Training and Doctrine Command (TRADOC)
In addition to the responsibilities in paragraph 2-19, the CG, TRADOC will—

a. Lead the Army in developing and validating battlefield requirements and use the force design update (FDU) process as the semiannual Army process to update organizational concepts and designs.

b. Develop organizational concepts and designs.

c. Provide USAFMSA completed unit reference sheets for FDU approved organization designs as the basis for TOE development.

"4-1. Concepts

"b. The TOE is the end product document of the Army's combat development process. It merges, in one document, the results of the requirements determination process...

"c. TOEs are the primary basis for stating Army requirements. This document heavily impacts the budget, the training base, efficiency, operational readiness, and overall management of Army resources.

"e. The TOE system is characterized by incremental TOEs that prescribe the wartime mission, capabilities, organizational structure, and minimum mission essential personnel and equipment requirements for military units. They portray the doctrinal modernization path (MODPATH) of a unit over time from the least modernized configuration to the most modernized.

"4-4. TOE review and revision

TOEs are normally revised as required to accommodate changes to doctrine, introduction of new equipment, or to incorporate more effective designs. Some TOEs are replaced by new organizations. Those TOEs that do not fall into the above categories will be reviewed not less than every three years from the date of approval.

"8-4. Type of organization

Criteria in Table 8-1 will be used to determine whether an organization should be documented as a MTOE, TDA, or AUGTDA.

"MTOE – The unit or organization is required to perform combat, CS, or CSS missions on a continuing basis.

"TDA – The unit or organization is part of a fixed support establishment, for example, installation, garrison."

AR 190-8, Enemy Prisoners of War, Retained Personnel, Civilian Internees and Other Detainees, 1 October 1997, Paragraph 1-1, subparagraph a, establishes the regulation as the source for policy for enemy prisoners of war (EPW), retained personnel (RP), civilian internees (CI) and other detainees (OD). The policy (written in 1997) is based on the Cold War model of an organized EPW population that is cooperative. The policy does not address the confinement of high-risk detainees. Paragraph 1-4, subparagraph g, establishes that EPW, RP, CI, and OD will be handed over to the Military Police (MP) or facilities run by the MPs. The regulation states that MPs have units specifically organized to perform the long-term functions associated with EPW/CI internment. The force structure of MP units does not support this requirement. The Glossary, Section II, defines the following terms: EPW, RP, CI, OD, and Detainee. The MP Corps has not yet developed or defined the term High Risk Detainee. This regulation is a multi-service regulation implementing DOD Directive 2310.1 and incorporates Army Regulation 190-8 and 190-57 and SECNAV Instruction 3461.3, and Air Force Joint Instruction 31-304 and outlines policies, procedures, and responsibilities for treatment of EPWs, RPs, CIs, and ODs and implements international law for all military operations. The specific language in the regulation follows:

"1-1. Purpose

a. This regulation provides policy, procedures, and responsibilities for the administration, treatment, employment, and compensation of enemy prisoners of war (EPW), retained personnel (RP), civilian internees (CI) and other detainees (OD) in the custody of U.S. Armed Forces. This regulation also establishes procedures for transfer of custody from the United States to another detaining power.

"1-4. Responsibilities

"g. *Combatant Commanders, Task Force Commanders and Joint Task Force Commanders*. Combatant Commanders, Task Force Commanders and Joint Task Force Commanders have the overall responsibility for the EPW, CI and RP program, operations, and contingency plans in the theater of operation involved to ensure compliance with international law of war. DOD Directive 2310.1 provides that persons captured or detained by the U.S. Military Services shall normally be handed over for safeguarding to U.S. Army Military Police, or

to detainee collecting points or other holding facilities and installations operated by U.S. Army Military Police as soon as practical. U.S. Army Military Police have units specifically organized to perform the long-term functions associated with EPW/CI internment.

"Glossary

"Section II Terms

"Civilian Internee(s). A civilian who is interned during armed conflict or occupation for security reasons or for protection or because he has committed an offense against the detaining power.

"Detainee. A term used to refer to any person captured or otherwise detained by an armed force.

"Enemy Prisoner of War. A detained person as defined in Articles 4 and 5 of the Geneva Convention Relative to the Treatment of Prisoners of War of August 12, 1949. In particular, one who, while engaged in combat under orders of his or her government, is captured by the armed forces of the enemy. As such, he or she is entitled to the combatant's privilege of immunity from the municipal law of the capturing state for warlike acts which do not amount to breaches of the law of armed conflict. For example, a prisoner of war may be, but is not limited to, any person belonging to one of the following categories who has fallen into the power of the enemy: a member of the armed forces, organized militia or volunteer corps; a person who accompanies the armed forces without actually being a member thereof; a member of a merchant marine or civilian aircraft crew not qualifying for more favorable treatment; or individuals who, on the approach of the enemy, spontaneously take up arms to resist invading forces.

"Other Detainee (OD). Persons in the custody of the U.S. Armed Forces who have not been classified as an EPW (article 4, GPW), RP (article 33, GPW), or CI (article 78, GC), shall be treated as EPWs until a legal status is ascertained by competent authority."

Field Manual (FM) 3-19.1, Military Police Operations, 31 January 2002, Paragraph 1-3, describes the doctrine review process the MP Corps underwent in 1996 and establishes and separates the internment and resettlement (I/R) function from the EPW mission. Paragraph 4-42 requires the Army to act as the Department of Defense's (DoD) Executive Agent for long-term confinement of U.S. Armed Forces prisoners. The paragraph goes on to address the MP's role in I/R functions, but does not address long-term confinement as an I/R function. The MP Corps does not address the doctrinal requirement for long-term I/R confinement or confinement of high-risk detainees. Paragraph 4-44 states the ratios by type of detainee that an MP (I/R) Battalion can support. This formula does not address confinement of high-risk detainees. The specific language in the field manual follows:

"1-3. In 1996, the MP Corps went through a doctrinal review process to determine if it was properly articulating its multiple performance capabilities in support of US forces deployed worldwide (see Appendix B). The review process identified the need to restructure and expand the EPW mission to include handling US military prisoners and all dislocated civilians. This new emphasis transformed the EPW mission into the internment and resettlement (I/R) function. The review process also identified the need to shift from missions to functions. In the past, the four battlefield missions adequately described MP capabilities in a mature theater against a

predictable, echeloned threat. However, that landscape is no longer valid. Accordingly, the four MP battlefield missions have become the following five MP functions:

- Maneuver and mobility support (MMS).
- AS.
- L&O.
- I/R.
- Police intelligence operations (PIO).

"4-42. The Army is the Department of Defense's (DOD's) executive agent for all EPW/Ci operations. Additionally, the Army is DOD's executive agent for longterm confinement of US military prisoners. Within the Army and through the combatant commander, the MP are tasked with coordinating shelter, protection, accountability, and sustainment for EPWs/CIs. The I/R function addresses MP roles when dealing with EPWs/CIs, dislocated civilians, and US military prisoners.

"4-44. Although the CS MP unit initially handles EPWs/CIs, modular MP (I/R) battalions with assigned MP guard companies and supporting MWD teams are equipped and trained to handle this mission for the long term. A properly configured modular MP (I/R) battalion can support, safeguard, account for, guard, and provide humane treatment for up to 4,000 EPWs/CIs; 8,000 dislocated civilians; or 1,500 US military prisoners."

FM 3-19.40, Military Police Internment/Resettlement Operations, 1 August 2001, Paragraph 1-13, states the objectives of I/R operations and the types of detainees expected. The terms refer to EPW, CI, RP, OD, dislocated civilian (DC), and U.S. Armed Forces prisoners. At the time this doctrine was written (August 2001) the MP Corps had not yet developed or defined the term high-risk detainee. The specific language in the field manual follows:

- "1-13. The objectives of I/R operations are to process, handle, care for, account for, and secure—
- EPWs.
 - CIs.
 - RPs.
 - ODs.
 - DCs.
 - US military prisoners."

o. Finding 15:

(1) **Finding:** Three of 4 inspected internment/resettlement facilities, and many of the collecting points, had inadequate force protection measures, Soldier working conditions, detainees living conditions, and did not meet the minimum preventive medical treatment requirements.

(2) **Standard:** Standard of treatment for detainees in OPERATION ENDURING FREEDOM (OEF): CJCS message dated 211933Z JAN 02 states that members of the Taliban militia and members of Al Qaida under the control of U.S. Forces would be treated humanely and, to the extent appropriate and consistent with military necessity, in a manner consistent with the principles of the Geneva Conventions of 1949. The DAIG has therefore used the provisions of the Geneva Conventions as a benchmark against which to measure the treatment provided to detainees by U.S. Forces to determine if detainees were treated humanely. The use of these

standards as benchmarks does not state or imply a position for the United States or U.S. Army on the legal status of its operations in OEF.

CJCS Message dated 211933Z JAN 02, provides the determination regarding the humane treatment of Al Qaida and Taliban detainees. Convention Relative to the Treatment of Prisoners of War of August 12, 1949 (GPW) is the international treaty that governs the treatment of prisoners of war, and Geneva Convention Relative to the Protection of Civilian Persons in Time of War (GC), August 12, 1949, is the international treaty that governs the treatment of civilian persons in time of war.

As the guidance did not define "humane treatment" but did state that the U.S. would treat members of the Taliban militia and Al Qaida in a manner consistent with the Geneva Conventions, the DAIG determined that it would use Common Article 3 of the GCs as its floor measure of humane treatment, but would also include provisions of the Geneva Convention on the Treatment of Prisoners of War (GPW) and Geneva Convention Relative to the Protection of Civilian Persons in Time of War (GC) as other relevant indicia of "humane treatment." The use of this standard does not state or imply a position for the United States or U.S. Army on the legal status of its operations in OEF.

Standard of treatment for detainees in OPERATION IRAQI FREEDOM (OIF): OIF was an international armed conflict and therefore the provisions of the Geneva Conventions applied. Additionally, the United States was an occupying power and has acted in accordance with the obligations of an occupying power described in the Hague Convention No. IV Respecting the Laws and Customs of War on Land (H.IV), Oct. 18, 1907, including, but not limited to, Articles 43-46 and 50; Geneva Convention Relative to the Treatment of Prisoners of War of August 12, 1949 (GPW); and Geneva Convention Relative to the Protection of Civilian Persons in Time of War (GC), August 12, 1949. The GC supplements H.IV, providing the general standard of treatment at Article 27 and specific standards in subsequent Articles.

The minimum treatment provided by Common Article 3 of the Geneva Conventions is: (1) No adverse distinction based upon race, religion, sex, etc.; (2) No violence to life or person; (3) No taking hostages; (4) No degrading treatment; (5) No passing of sentences in absence of fair trial, and; (6) The wounded and sick must be cared for.

The specific language in the CJCS Message for OEF and the GPW/GC and H.IV follows:

CJCS Message dated 211933Z JAN 02, "Paragraph 3. The combatant commanders shall, in detaining Al Qaida and Taliban individuals under the control of the Department of Defense, treat them humanely and, to the extent appropriate and consistent with military necessity, in a manner consistent with the principles of the Geneva Conventions of 1949."

GPW/GC, Article 3 (Common Article 3) – "In the case of armed conflict not of an international character occurring in the territory of one of the High Contracting Parties, each party to the conflict shall be bound to apply, as a minimum, the following provisions:

1. Persons taking no active part in the hostilities, including members of armed forces who have laid down their arms and those placed hors de combat by sickness, wounds, detention, or any other cause, shall in all circumstances be treated humanely, without any adverse distinction founded on race, color, religion or faith, sex, birth or wealth, or any other similar criteria.

To this end the following acts are and shall remain prohibited at any time and in any place whatsoever with respect to the above-mentioned persons:

- (a) Violence to life and person, in particular murder of all kinds, mutilation, cruel treatment and torture;
- (b) Taking of hostages;
- (c) Outrages upon personal dignity, in particular, humiliating and degrading treatment;
- (d) The passing of sentences and the carrying out of executions without previous judgment pronounced by a regularly constituted court affording all the judicial guarantees which are recognized as indispensable by civilized peoples.

2. The wounded and sick shall be collected and cared for. An impartial humanitarian body, such as the International Committee of the Red Cross, may offer its services to the Parties to the conflict. The Parties to the conflict should further endeavour to bring into force, by means of special agreements, all or part of the other provisions of the present Convention. The application of the preceding provisions shall not affect the legal status of the Parties to the conflict."

Haague Convention No. IV Respecting the Laws and Customs of War on Land (H.IV.), Oct. 18, 1907, Articles 43-46 and 50; and Geneva Convention Relative to the Protection of Civilian Persons in Time of War (GC), Aug 12, 1949, Articles 81, 83, 85, 88, 89, and 91 discuss the requirement to accommodate detainees in buildings or quarters which afford every possible safeguard regarding health and hygiene and the effects of war. The specific language in the GC follows:

GC Article 81 – "Parties to the conflict who intern protected persons shall be bound to provide free of charge for their maintenance, and to grant them also the medical attention required by their state of health. No deduction from the allowances, salaries or credits due to the internees shall be made for the repayment of these costs."

GC, Article 83 – "The Detaining Power shall not set up places of internment in areas particularly exposed to the dangers of war. ..."

GC, Article 85 – "The Detaining Power is bound to take all necessary and possible measures to ensure that protected persons shall, from the outset of their internment, be accommodated in buildings or quarters which afford every possible safeguard as regards hygiene and health, and provide efficient protection against the rigors of the climate and the effects of the war. In no case shall permanent places of internment be situated in unhealthy areas or in districts, the climate of which is injurious to the internees. In all cases where the district, in which a protected person is temporarily interned, is an unhealthy area or has a climate which is harmful to his health, he shall be removed to a more suitable place of internment as rapidly as circumstances permit. The premises shall be fully protected from dampness, adequately heated and lighted, in particular between dusk and lights out. The sleeping quarters shall be sufficiently spacious and well ventilated, and the internees shall have suitable bedding and sufficient blankets, account being taken of the climate, and the age, sex, and state of health of the internees. Internees shall have for their use, day and night, sanitary conveniences which conform to the rules of hygiene, and are constantly maintained in a state of cleanliness. They shall be provided with sufficient water and soap for their daily personal toilet and for washing their personal laundry; installations and facilities necessary for this purpose shall be granted to them. Showers or baths shall also be available. The necessary time shall be

set aside for washing and for cleaning. Whenever it is necessary, as an exceptional and temporary measure, to accommodate women internees who are not members of a family unit in the same place of internment as men, the provision of separate sleeping quarters and sanitary conveniences for the use of such women internees shall be obligatory."

GC, Article 88 – "In all places of internment exposed to air raids and other hazards of war, shelters adequate in number and structure to ensure the necessary protection shall be installed. ..."

GC, Article 89 – "Daily food rations for internees shall be sufficient in quantity, quality and variety to keep internees in a good state of health and prevent the development of nutritional deficiencies. Account shall also be taken of the customary diet of the internees. Internees shall also be given the means by which they can prepare for themselves any additional food in their possession. Sufficient drinking water shall be supplied to internees. ... "

GC Article 91 – "Every place of internment shall have an adequate infirmary, under the direction of a qualified doctor, where internees may have the attention they require, as well as appropriate diet. Isolation wards shall be set aside for cases of contagious or mental diseases. Maternity cases and internees suffering from serious diseases, or whose condition requires special treatment, a surgical operation or hospital care, must be admitted to any institution where adequate treatment can be given and shall receive care not inferior to that provided for the general population. Internees shall, for preference, have the attention of medical personnel of their own nationality. Internees may not be prevented from presenting themselves to the medical authorities for examination. The medical authorities of the Detaining Power shall, upon request, issue to every internee who has undergone treatment an official certificate showing the nature of his illness or injury, and the duration and nature of the treatment given. A duplicate of this certificate shall be forwarded to the Central Agency provided for in Article 140 Treatment, including the provision of any apparatus necessary for the maintenance of internees in good health, particularly dentures and other artificial appliances and spectacles, shall be free of charge to the internee."

GPW, Article 29 – "The Detaining Power shall be bound to take all sanitary measures necessary to ensure the cleanliness and healthfulness of camps and to prevent epidemics.

Prisoners of war shall have for their use, day and night, conveniences which conform to the rules of hygiene and are maintained in a constant state of cleanliness. In any camps in which women prisoners of war are accommodated, separate conveniences shall be provided for them.

Also, apart from the baths and showers with which the camps shall be furnished, prisoners of war shall be provided with sufficient water and soap for their personal toilet and for washing their personal laundry; the necessary installations, facilities and time shall be granted them for that purpose."

Army Regulation (AR) 40-5, Preventive Medicine, 15 October 1990, Chapter 14, paragraph 14-3, subparagraph a, requires field sanitation teams at all company-level units. The specific language in the regulation follows:

"a. Functions. As a minimum, units deploying to the field will—

- (1) Before deployment, appoint a field sanitation team with responsibilities defined in b below.
- (2) Before deployment, incorporate PMM into SOPs.
- (3) Have the capability to use pesticides and vegetation controls.
- (4) Bury and/or burn wastes to prevent the breeding of insects and rodents. Consult the environmental coordinator or PVNTMED personnel to ensure compliance with local environmental regulations and laws during field exercises.
- (5) Protect food during storage and preparation to prevent contamination (TB MED 530).
- (6) Monitor unit water sources to assure adequate supplies and disinfection.
- (7) Arrange for maintenance of immunizations and prophylaxis.
- (8) Use other appropriate measures under FM 21-10 / AFM 161-10.
- (9) Assure command supervision of individual PMM.
- (10) Request assistance for problems exceeding unit capabilities.
- (11) Deploy to the field with field sanitation equipment listed in table 14-1."

Army Regulation (AR) 190-8, Enemy Prisoners of War, Retained Personnel, Civilian Internees and Other Detainees, 1 October 1997, Chapter 1, paragraph 1-4, subparagraph g (6) (a), discusses sanitary aspects of food service and the need to provide potable water and vector control. Chapter 3, paragraph 3-2, subparagraph b, requires internment/resettlement (I/R) facilities and collecting points (CPs) to operate under the same standards of hygiene and sanitation. Paragraph 3-4, subparagraph e, requires enemy prisoners of war/retained personnel (EPW/RP) to be housed under the same conditions as US forces residing in the same area; subparagraph i requires EPW/RP facilities to ensure a clean and healthy environment for detainees. Chapter 5, paragraph 5-2, subparagraph a, states that a safety program for civilian internees (CIs) will be established. Chapter 6, paragraph 6-1, subparagraph b, discusses minimum standards to house (CIs). Paragraph 6-5 discusses subsistence requirement for CIs, and paragraph 6-6 covers medical care and sanitation. This regulation is a multi-service regulation implementing DoD Directive 2310.1 and incorporates Army Regulation 190-8 and 190-57 and SECNAV Instruction 3461.3, and Air Force Joint Instruction 31-304 and outlines policies, procedures, and responsibilities for treatment of enemy prisoners of war (EPW), retained personnel (RP), civilian internees (CI), and other detainees (OD) and implements international law for all military operations. The specific language in the regulation follows:

3-2. b. – "Prisoners will not normally be interned in unhealthy areas, or where the climate proves to be injurious to them, and will be removed as soon as possible to a more favorable climate. Transit camps or collecting points will operate under conditions similar to those prescribed for permanent prisoner of war camps, and the prisoners will receive the same treatment as in permanent EPW camps.

3-4. e. – "EPW/RP will be quartered under conditions as favorable as those for the force of the detaining power billeted in the same area. The conditions shall make allowance for the habits and customs of the prisoners and shall in no case be prejudicial to their health. The forgoing shall apply in particular to the dormitories of EPW/RP as it regards both total surface and minimum cubic space and the general installation of bedding and blankets. Quarters furnished to EPW/RP must be protected from dampness, must be adequately lit and heated (particularly between dusk and lights-out), and must have adequate precautions taken against the dangers of fire. In camps accommodating both sexes, EPW/RP will be provided with separate facilities for women.

3-4. i. – "Hygiene and medical care:

(1) The United States is bound to take all sanitary measures necessary to ensure clean and healthy camps to prevent epidemics. EPW/RP will have access, day and night, to latrines that conform to the rules of hygiene and are maintained in a constant state of cleanliness. In any camps in which women EPW/RP are accommodated, separate latrines will be provided for them. EPW/RP will have sufficient water and soap for their personal needs and laundry.

"(6) Identify requirements and allocations for Army Medical units in support of the EPW, CI and RP Program, and ensure that the medical annex of OPLANs, OPODs and contingency plans includes procedures for treatment of EPW, CI, RP, and ODs. Medical support will specifically include:

(a) First aid and all sanitary aspects of food service including provisions for potable water, pest management, and entomological support.

"5-2. Civilian Internee Safety Program

a. Establishment. A safety program for the CI will be established and administered in accordance with the policies prescribed in AR 385-10 and other pertinent safety directives.

"6-1. Internment Facility

a. Location. The theater commander will be responsible for the location of the CI internment facilities within his or her command. The CI retained temporarily in an unhealthy area or where the climate is harmful to their health will be removed to a more suitable place of internment as soon as possible.

b. Quarters. Adequate shelters to ensure protection against air bombardments and other hazards of war will be provided and precautions against fire will be taken at each CI camp and branch camp.

(1) All necessary and possible measures will be taken to ensure that CI shall, from the outset of their internment, be accommodated in buildings or quarters which afford every possible safeguard as regards hygiene and health, and provide efficient protection against the rigors of the climate and the effects of war. In no case shall permanent places of internment be placed in unhealthy areas, or in districts the climate of which is injurious to CI.

(2) The premises shall be fully protected from dampness, adequately heated and lighted, in particular between dusk and lights out. The sleeping quarters shall be sufficiently spacious and well ventilated, and the internees shall have suitable bedding and sufficient blankets, account being taken of the climate, and the age, sex and state of health of the internees.

(3) Internees shall have for their use, day and night, sanitary conveniences which conform to the rules of hygiene and are constantly maintained in a state of cleanliness. They shall be provided with sufficient water and soap for their daily personal hygiene and for washing their personal laundry; installations and facilities necessary for this purpose shall be provided. Showers or baths shall also be available. The necessary time shall be set aside for washing and for cleaning.

(4) CI shall be administered and housed separately from EPW/RP. Except in the case of families, female CI shall be housed in separate quarters and shall be under the direct supervision of women.

"6-5. Supplies.

"b. Food.

(1) Subsistence for the CI will be issued on the basis of a master CI menu prepared by the theater commander. Preparation of the menu will include the following:

(a) The daily individual food ration will be sufficient in quantity, quality, and variety to maintain the CI in good health and to prevent nutritional deficiencies.

"6-6. Medical Care and Sanitation.

a. General

"(2) A medical officer will examine each CI upon arrival at a camp and monthly thereafter. The CI will not be admitted into the general population until medical fitness is determined. These examinations will detect vermin infestation and communicable diseases especially tuberculosis, malaria, and venereal disease. They will also determine the state of health, nutrition, and cleanliness of each CI. During these examinations, each CI will be weighed, and the weight will be recorded on DA Form 2664-R."

AR 385-10, The Army Safety Program, 29 February 2000, Chapter 1, paragraph 1-4, paragraph n, subparagraph (1) (a), discusses commanders' responsibilities in implementing the Army Safety Program. Paragraph 1-5, subparagraph b, states that all decision makers will employ the risk management process. Chapter 2, paragraph 2-2, subparagraph b, states that the risk management process will be incorporated into SOPs. Paragraph 2-3, subparagraph d, discusses that, as a minimum requirement, annual inspections or surveys will be conducted on facilities—more inspections may be required based on risk. The specific language in the regulation follows:

"n. MACOM commanders will—(1) Ensure the full and effective implementation of the Army safety and OH program throughout their MACOM. This includes—(a) Providing a safe and healthful workplace and environment.

"b. Decision makers at every level will employ the risk management process, as specified in paragraph 2-3d of this regulation, to avoid unnecessary residual risk to missions, personnel, equipment, and the environment.

"2-2. Operational procedures. Leaders and managers are responsible for integrating risk management into all Army processes and operations. Safety and occupational health staffs will provide risk management training, tools and other related assistance. Leaders and managers will—

"b. Ensure that the risk management process is incorporated in regulations, directives, SOPs, special orders, training plans, and operational plans to minimize accident risk and that SOPs are developed for all operations entailing risk of death, serious injury, occupational illness or property loss.

"2-3. Prevention program procedures. a. Inspections and surveys. Inspections and surveys of operations and facilities will be conducted annually or more often (chap 4).

"d. Risk management. Risk Management is the Army's principal risk reduction process to assist leaders in identifying and controlling hazards and making informed decisions. (1) Every commander, leader and manager is responsible for protecting the force and persons affected by Army operations. The five-step process is the commander's principal risk reduction process to identify and control hazards and make informed decisions. (a) Identify hazards. (b) Assess hazards. (c) Develop controls and make risk decisions. (d) Implement controls. (e) Supervise and evaluate."

AR 420-70, Buildings and Structures, 10 October 1997, Chapter 2, paragraph 2-10, subparagraph a, states that lead based paint will not be used in Army facilities. The specific language in the regulation follows:

"a. Lead-based paint (LBP). LBP will not be applied to any Army facility."

Field Manual (FM) 3-19.4, Military Police Leaders' Handbook, 4 March 2002, Chapter 7, paragraph 7-8, states that detainees do not remain at forward collecting points more than 12 hours before moving to the central collecting point. Paragraph 7-9 states that existing structures should be used when possible. Paragraph 7-29 discusses safeguarding and protecting detainees from attack. Paragraph 7-30 discusses GS MPs and their role in establishing division central collecting points. Paragraph 7-33 discusses MP roles in escorting detainees from forward collecting points to division central collecting points within 12 hours. Paragraph 7-58, discusses the physical criteria for collecting points. The specific language in the field manual follows:

"7-8. ... Units needed to support the division forward collecting point should be specifically tasked in the brigade OPORD. MP leaders operating the division forward collecting point will—

- Ensure that captives do not remain at the division forward collecting point more than 12 hours before being escorted to the division central collecting point.

7-9. A forward collecting point (Figure 7-1, page 7-6) should not be set up near local inhabitants. Existing structures like vacant schools, apartments, or warehouses should be used when possible. This reduces construction requirements and minimizes logistical requirements. If existing structures are not used, detainees, except officers, can be tasked to help construct the collecting point. Prisoners may dig or build cover to protect themselves from artillery, mortar, or air attack. There is no set design for a forward collecting point. It can be anything from a guarded, roped off area to a secured, existing structure. The collecting point is built to suit the climate, the weather, and the situation. When selecting a collecting point, consider the following:

- The security of the detainees. The perimeters of the enclosure must be clearly defined and understood by the detainees.
- First aid. Injured or ill detainees require the same treatment that would be given to US casualties.
- Food and water. Detainees may have been without food or water for a long time before capture.
- Latrine facilities.
- Field sanitation. If possible, have detainees wash with soap and water to reduce the likelihood of disease.

- Shelter and cover.
- Language barriers. Provide interpreters and/or instructional graphic training aids (GTAs) in the EPW native language to compensate for the language differences.

"7-29. Protecting detainees from attack, preventing their escape, and quickly removing them from the battle area further safeguards them. Detainees should not remain at the division forward collecting point more than 12 hours, if possible. MP from the division central collecting point move forward to escort detainees back to the central collecting points.

7-30. MP in GS are responsible for establishing and maintaining the division central collecting point. They collect detainees from the forward collecting points, then process and secure them until corps MP come forward to evacuate them to the rear. Detainees should be transferred to the corps holding area or directly to an internment facility within 24 hours, if possible. One or more GS MP platoons operate the division central collecting point. The MP platoons are augmented by the division band and/or by the corps MP. Augmentation is based on the number and rate of captives expected.

"7-33. The MP platoon charged with operating the division central collecting point sends MP forward to the division forward collecting point to escort detainees back to the central collecting point. EPWs or CIs must be evacuated from the division forward collecting point as soon as possible, preferably within 12 hours. Before evacuating the detainees, MP checks with MI interrogation teams for any property to be returned to, or evacuated with, the detainees before they are moved.

"7-58. The size of the facility is based on the number of prisoners being detained. It may be room or a tent, as long as it provides shelter equal to that offered to other soldiers in the combat zone. The physical criteria for permanent and temporary structures are the same. MP use existing structures if you can. Otherwise, they use tents. ...

FM 3-19.40, Military Police Internment/Resettlement Operations, 1 August 2001, Chapter 2, paragraph 2-1, discusses the Military Police Battalion Commander's responsibilities. Paragraph 2-1 states the role of the MP battalion commander, paragraph 2-17 discusses the requirement for a safety program for I/R facilities, and paragraph states the engineer officer's responsibilities. Paragraph 2-37 states the responsibility of the engineer officer. Chapter 6, paragraphs 6-2 and 6-3 discuss the considerations of choosing sites for Internment/Resettlement (I/R) facilities. The specific language in the field manual follows:

"2-1. An MP battalion commander tasked with operating an I/R facility is also the facility commander. As such, he is responsible for the safety and well-being of all personnel housed within the facility. Since an MP unit may be tasked to handle different categories of personnel (EPW, CI, OD, refugee, and US military prisoner), the commander, the cadre, and support personnel must be aware of the requirements for each category.

"2-17. Set up and administer a safety program for housed personnel in each I/R facility. Follow the procedures outlined in AR 385-10 and associated circulars and pamphlets to establish the safety program. Maintain records and reports for the internee safety program separate from those for the Army safety program.

"2-37. The engineer officer is a captain in a brigade and a lieutenant in a battalion. He trains and supervises internees who perform internal and external labor (construction and repair of facilities). The engineer officer is responsible for—

- Construction, maintenance, repair, and operation of utilities (water, electricity, heat, and sanitation).
- Construction support.
- Fire protection.
- Insect and rodent control and fumigation.

"6-2. The MP coordinate the location with engineers, logistical units, higher headquarters, and the HN. The failure to properly consider and correctly evaluate all factors may increase the logistical and personnel efforts required to support operations. If an I/R facility is improperly located, the entire internee population may require movement when resources are scarce. When selecting a site for a facility, consider the following:

- Will the interned population pose a serious threat to logistical operations if the tactical situation becomes critical?
- Is there a threat of guerrilla activity in the area?
- What is the attitude of the local population?
- What classification of internees will be housed at the site?
- What type of terrain surrounds the site, and will it help or hinder escapes?
- What is the distance from the MSR to the source of logistical support?
- What transportation methods are required and available to move internees, supplies, and equipment?

6-3. In addition, consider the—

- METT-TC.
- Proximity to probable target areas.
- Availability of suitable existing facilities (avoids unnecessary construction).
- Presence of swamps, mosquitoes, and other factors (including water drainage) that affect human health.
 - Existence of an adequate, satisfactory source of potable water. The supply should meet the demands for consumption, food sanitation, personal hygiene, and sewage disposal.
 - Availability of electricity. Portable generators can be used as standby and emergency sources of electricity.
 - Distance to work if internees are employed outside the facility.
 - Availability of construction material.
 - Soil drainage."

p. **Finding 16:**

(1) **Finding:** Two of 4 internment/resettlement facilities did not segregate enemy prisoners of war from civilian internees in accordance with legal requirements.

(2) **Standard:** Standard of treatment for detainees in OPERATION ENDURING FREEDOM (OEF): CJCS message dated 211933Z JAN 02 states that members of the Taliban militia and members of Al Qaida under the control of U.S. Forces would be treated humanely and, to the extent appropriate and consistent with military necessity, in a manner consistent with the principles of the Geneva Conventions of 1949. The DAIG has therefore used the provisions of the Geneva Conventions as a benchmark against which to measure the treatment provided to

detainees by U.S. Forces to determine if detainees were treated humanely. The use of these standards as benchmarks does not state or imply a position for the United States or U.S. Army on the legal status of its operations in OEF.

CJCS Message dated 211933Z JAN 02, provides the determination regarding the humane treatment of Al Qaida and Taliban detainees. Convention Relative to the Treatment of Prisoners of War of August 12, 1949 (GPW) is the international treaty that governs the treatment of prisoners of war, and Geneva Convention Relative to the Protection of Civilian Persons in Time of War (GC), August 12, 1949, is the international treaty that governs the treatment of civilian persons in time of war.

As the guidance did not define "humane treatment" but did state that the U.S. would treat members of the Taliban militia and Al Qaida in a manner consistent with the Geneva Conventions, the DAIG determined that it would use Common Article 3 of the GCs as its floor measure of humane treatment, but would also include provisions of the Geneva Convention on the Treatment of Prisoners of War (GPW) and Geneva Convention Relative to the Protection of Civilian Persons in Time of War (GC) as other relevant indicia of "humane treatment." The use of this standard does not state or imply a position for the United States or U.S. Army on the legal status of its operations in OEF.

Standard of treatment for detainees in OPERATION IRAQI FREEDOM (OIF): OIF was an international armed conflict and therefore the provisions of the Geneva Conventions applied. Additionally, the United States was an occupying power and has acted in accordance with the obligations of an occupying power described in the Hague Convention No. IV Respecting the Laws and Customs of War on Land (H.IV), Oct. 18, 1907, including, but not limited to, Articles 43-46 and 50; Geneva Convention Relative to the Treatment of Prisoners of War of August 12, 1949 (GPW); and Geneva Convention Relative to the Protection of Civilian Persons in Time of War (GC), August 12, 1949. The GC supplements H.IV, providing the general standard of treatment at Article 27 and specific standards in subsequent Articles.

The minimum treatment provided by Common Article 3 of the Geneva Conventions is: (1) No adverse distinction based upon race, religion, sex, etc.; (2) No violence to life or person; (3) No taking hostages; (4) No degrading treatment; (5) No passing of sentences in absence of fair trial, and; (6) The wounded and sick must be cared for.

The specific language in the CJCS Message for OEF and the GPW/GC and H.IV follows:

CJCS Message dated 211933Z JAN 02, "Paragraph 3. The combatant commanders shall, in detaining Al Qaida and Taliban individuals under the control of the Department of Defense, treat them humanely and, to the extent appropriate and consistent with military necessity, in a manner consistent with the principles of the Geneva Conventions of 1949."

GPW/GC, Article 3 (Common Article 3) – "In the case of armed conflict not of an international character occurring in the territory of one of the High Contracting Parties, each party to the conflict shall be bound to apply, as a minimum, the following provisions:

1. Persons taking no active part in the hostilities, including members of armed forces who have laid down their arms and those placed hors de combat by sickness, wounds, detention, or any other cause, shall in all circumstances be treated humanely, without any

adverse distinction founded on race, color, religion or faith, sex, birth or wealth, or any other similar criteria.

To this end the following acts are and shall remain prohibited at any time and in any place whatsoever with respect to the above-mentioned persons:

- (a) Violence to life and person, in particular murder of all kinds, mutilation, cruel treatment and torture;
- (b) Taking of hostages;
- (c) Outrages upon personal dignity, in particular, humiliating and degrading treatment;
- (d) The passing of sentences and the carrying out of executions without previous judgment pronounced by a regularly constituted court affording all the judicial guarantees which are recognized as indispensable by civilized peoples.

2. The wounded and sick shall be collected and cared for. An impartial humanitarian body, such as the International Committee of the Red Cross, may offer its services to the Parties to the conflict. The Parties to the conflict should further endeavour to bring into force, by means of special agreements, all or part of the other provisions of the present Convention. The application of the preceding provisions shall not affect the legal status of the Parties to the conflict."

Geneva Convention Relative to the Protection of Civilian Persons in Time of War (GC), Article 84; and Geneva Convention Relative to the Treatment of Prisoners of War (GPW), Article 17. The specific language in the Geneva Conventions follows:

GC, Article 84 – "Internees shall be accommodated and administered separately from prisoners of war and from persons deprived of liberty for any other reason."

GPW, Article 17 – "Every prisoner of war, when questioned on the subject, is bound to give only his surname, first names and rank, date of birth, and army, regimental, personal or serial number, or failing this, equivalent information. If he willfully infringes this rule, he may render himself liable to a restriction of the privileges accorded to his rank or status. Each Party to a conflict is required to furnish the persons under its jurisdiction who are liable to become prisoners of war, with an identity card showing the owner's surname, first names, rank, army, regimental, personal or serial number or equivalent information, and date of birth. The identity card may, furthermore, bear the signature or the fingerprints, or both, of the owner, and may bear, as well, any other information the Party to the conflict may wish to add concerning persons belonging to its armed forces. As far as possible the card shall measure 6.5 x 10 cm. and shall be issued in duplicate. The identity card shall be shown by the prisoner of war upon demand, but may in no case be taken away from him. No physical or mental torture, nor any other form of coercion, may be inflicted on prisoners of war to secure from them information of any kind whatever. Prisoners of war who refuse to answer may not be threatened, insulted, or exposed to any unpleasant or disadvantageous treatment of any kind. Prisoners of war who, owing to their physical or mental condition, are unable to state their identity, shall be handed over to the medical service. The identity of such prisoners shall be established by all possible means, subject to the provisions of the preceding paragraph. The questioning of prisoners of war shall be carried out in a language which they understand."

q. Finding 17:

(1) **Finding:** Units operating collecting points (42%, 5 of 12), and 2 of 4 units operating internment/resettlement facilities, were not adequately resourced with communications equipment, shotguns, and non-lethal ammunition.

(2) **Standard:** Army Regulation (AR) 190-8, Enemy Prisoners of War, Retained Personnel, Civilian Internees and Other Detainees, 1 October 1997, Chapter 1, paragraph 1-4, subparagraph e, states that the G4 is responsible for logistics. Paragraph 1-4, subparagraph g (2), states that Combatant Commanders, Task Force Commanders, and Joint Task Force Commanders have overall responsibility for civilian internee (CI) programs and in the planning and procuring for logistical support. This regulation is a multi-service regulation implementing DOD Directive 2310.1 and incorporates Army Regulation 190-8 and 190-57 and SECNAV Instruction 3461.3, and Air Force Joint Instruction 31-304 and outlines policies, procedures, and responsibilities for treatment of enemy prisoners of war (EPW), retained personnel (RP), civilian internees (CI), and other detainees (OD) and implements international law for all military operations. The specific language in the regulation follows:

"e. Deputy Chief of Staff for Logistics (DCSLOG). The DCSLOG will ensure logistical resources are available to support EPW operations."

"g. Combatant Commanders, Task Force Commanders and Joint Task Force Commanders. Combatant Commanders, Task Force Commanders and Joint Task Force Commanders have the overall responsibility for the EPW, CI and RP program, operations, and contingency plans in the theater of operation involved to ensure compliance with international law of war."

"(2) Plan and procure logistical support to include: transportation, subsistence, personal, organizational and Nuclear, Biological & Chemical (NBC) clothing and equipment items, mail collection and distribution, laundry, and bath for EPW, CI and RP."

Field Manual (FM) 3-19.40, Military Police Internment/Resettlement Operations, 1 August 2001, Chapter 6, paragraph 6-7, discusses the importance of good communication within a facility. The specific language in the field manual follows:

"6-7.

- Communications. Ensure that communication between towers and operation headquarters is reliable. Telephones are the preferred method; however, ensure that alternate forms of communication (radio and visual or sound signals) are available in case telephones are inoperable."

r. Finding 18:

(1) **Finding:** All inspected point of capture units established ad hoc kits containing necessary items and supplies for detainee field processing, but the items they contained and their quantities varied from unit to unit.

(2) **Standard:** There is no regulatory standard for a detainee field processing kit for capturing units. Army Regulation (AR) 190-8, Enemy Prisoners of War, Retained Personnel, Civilian Internees and Other Detainees, 1 October 1997, Chapter 1, paragraph 1-4,

subparagraph g (2), states that Combatant Commanders, Task Force Commanders, and Joint Task Force Commanders have overall responsibility for civilian internee (CI) programs and in the planning and procuring for logistical support. Chapter 2, paragraph 2-1, subparagraph a (1) (a) & (b), requires a capturing unit to document confiscated currency and to tag all captured prisoners. This regulation is a multi-service regulation implementing DOD Directive 2310.1 and incorporates Army Regulation 190-8 and 190-57 and SECNAV Instruction 3461.3, and Air Force Joint Instruction 31-304 and outlines policies, procedures, and responsibilities for treatment of enemy prisoners of war (EPW), retained personnel (RP), civilian internees (CI), and other detainees (OD) and implements international law for all military operations. The specific language in the regulation follows:

"g. Combatant Commanders, Task Force Commanders and Joint Task Force Commanders. Combatant Commanders, Task Force Commanders and Joint Task Force Commanders have the overall responsibility for the EPW, CI and RP program, operations, and contingency plans in the theater of operation involved to ensure compliance with international law of war."

"(2) Plan and procure logistical support to include: transportation, subsistence, personal, organizational and Nuclear, Biological & Chemical (NBC) clothing and equipment items, mail collection and distribution, laundry, and bath for EPW, CI and RP."

"a. Each EPW/RP will be searched immediately after capture. ... Currency will only be confiscated on the order of a commissioned officer and will be receipted for using a DA Form 4137 (Evidence/Property Custody Document).

b. All prisoners of war and retained persons will, at the time of capture, be tagged using DD Form 2745. They will be searched for concealed weapons and items of intelligence. All equipment, documents, and personal property confiscated during the search must be tagged and administratively accounted for by the capturing unit. Capturing units must provide the: date of capture, location of capture (how the EPW was captured). The remaining information will be included on the tag as it becomes available."

s. Finding 19:

(1) Finding: All inspected units had adequate transportation assets to evacuate and/or transfer detainees from points of capture to collecting points, and eventually to internment/resettlement facilities.

(2) Standard: Army Regulation 190-8, Enemy Prisoners of War, Retained Personnel, Civilian Internees and Other Detainees, 1 October 1997, Chapter 1, paragraph 1-4, subparagraph g (2) and (5), states that Combatant Commanders, Task Force Commanders, and Joint Task Force Commanders have overall responsibility for civilian internee (CI) programs and in the planning and procuring for logistical support, to include transportation. This regulation is a multi-service regulation implementing DOD Directive 2310.1 and incorporates Army Regulation 190-8 and 190-57 and SECNAV Instruction 3461.3, and Air Force Joint Instruction 31-304 and outlines policies, procedures, and responsibilities for treatment of enemy prisoners of war (EPW), retained personnel (RP), civilian internees (CI), and other detainees (OD) and implements international law for all military operations. The specific language in the regulation follows:

"(2) Plan and procure logistical support to include: transportation, subsistence, personal, organizational and Nuclear, Biological & Chemical (NBC) clothing and equipment items, mail collection and distribution, laundry, and bath for EPW, CI and RP."

"(5) Establish guidance for the use, transport, and evacuation of EPW, CI, RP, and ODs in logistical support operations."

Field Manual 3-19.40, Military Police Internment/Resettlement Operations, 1 August 2001, Chapter 3, paragraph 3-7, states that the basic principle of speed is the responsibility of the capturing unit, who moves the detainee to the collecting point (CP). Paragraph 3-18 states that the number of detainees at the CP must be reported through MP channels to assist in the transportation planning. Paragraph 3-26 states who is responsible for moving detainees from CPs to the internment/resettlement facility. Paragraph 3-33 states the ratio of MP guards to detainees for movement. Paragraph 3-34 states that detainees cannot be moved with MP organic assets. Paragraph 3-35 states that the preferred method of detainee movement is by using the backhaul system. The specific language in the field manual follows:

"3-7. The Five Ss and T procedure is performed by the capturing unit. The basic principles are search, segregate, silence, speed, safeguard, and tag."

"3-18. Report the number of captives at each CP through MP channels. This aids in the transportation and security planning processes."

"3-26. Remove captives from the CZ as quickly as possible. The intent is to move them from division CPs to an I/R facility. The goal is for higher-level echelons to go forward to lower echelons and evacuate captives to the rear as follows:

- Division MP move forward to the forward CP to escort captives to the central CP.
- Corps MP move forward to the central CP to escort captives to the CHA.
- Echelons above corps (EAC) MP move forward to the CHA to escort captives to the I/R facility."

"3-33. The MP guard able-bodied captives during movement to prevent escape, liberation, or injury. A general planning consideration when determining the number of MP necessary is one for every five to ten captives.

3-34. When moving forward to escort captives to the rear area, MP responsibilities begin at the CP or the CHA where custody is accepted. Verify the method of moving captives, the location and time of pick-up, and the number of captives contained in orders from higher headquarters. The MP units cannot transport captives with organic assets.

3-35. The preferred method for moving captives through a battlefield is the backhaul system. This transportation system relies on assets that have delivered their primary cargo and are available to move personnel and materials to another location. The availability of vehicles will vary, depending on the cargo delivered to the area. The command and control (C2) element of MP unit tasked with evacuation arranges transportation through the local MCO."

t. **Finding 20:**

(1) **Finding:** Common leader training in professional military school contains only one detainee operations task.

(2) **Standard:** Army Regulation 350-1, Army Training and Education, 9 April 2003, Chapter 3, paragraph 3-2, requires that TRADOC establish training and education goals and objectives for all Army personnel. The specific language in the regulation follows:

"Training proponents. These would include TRADOC schools and colleges, USAJFKSWC&S and AMEDDC&S and would perform the following:

(a) Develop courses based on established training and education goals and objectives as well as the duties, responsibilities, and missions their graduates will be assigned.

(b) Develop, evaluate, and train leader, technical, and tactical tasks that focus on missions for the size or type units to which graduates will be assigned.

(c) Provide progressive and sequential training.

(d) Provide personnel serving at the same organizational level with training consisting of the same tasks, conditions, and standards.

(e) Provide leader, technical, and tactical training that affords soldiers and DA civilians an opportunity to acquire the skills and knowledge needed to perform more complex duties and missions of greater responsibility."

Field Manual (FM) 7-0, Training the Force, 22 October 2002, Chapter 1, paragraph 1-29, provides overall guidance for the implementation of Professional Military Education (PME). The specific language in the field manual follows:

"Professional Military Education - PME develops Army leaders. Officer, warrant officer, and NCO training and education is a continuous, career-long, learning process that integrates structured programs of instruction—resident at the institution and non-resident via distributed learning at home station. PME is progressive and sequential, provides a doctrinal foundation, and builds on previous training, education and operational experiences. PME provides hands-on technical, tactical, and leader training focused to ensure leaders are prepared for success in their next assignment and higher-level responsibility.

- **Officer Education System (OES).** Army officers must lead and fight; be tactically and technically competent; possess leader skills; understand how the Army operates as a service, as well as a component of a joint, multinational, or interagency organization; demonstrate confidence, integrity, critical judgment, and responsibility; operate in a complex, uncertain, and rapidly changing environment; build effective teams amid continuous organizational and technological change; and solve problems creatively. OES develops officers who are self-aware and adaptive to lead Army units to mission success.

- **Warrant Officer Education System (WOES).** Warrant officers are the Army's technical experts. WOES develops a corps of highly specialized experts and trainers who are fully competent and proficient operators, maintainers, administrators, and managers of the Army's equipment, support activities, and technical systems.

- NCO Education System (NCOES). NCOES trains NCOs to lead and train soldiers, crews, and subordinate leaders who work and fight under their leadership. NCOES provides hands-on technical, tactical, and leader training focused to ensure that NCOs are prepared for success in their next assignment and higher-level responsibility.

- Functional Training. In addition to the preceding PME courses, there are functional courses available in both resident and non-resident distributed learning modes that enhance functional skills for specific duty positions. Examples are Battalion S2, Battalion Motor Officer, First Sergeant, Battle Staff NCO, and Airborne courses."

u. Finding 21:

(1) **Finding:** Leaders and Soldiers assigned to 69% (46 of 67) of inspected units stated they desired additional home station training; and pre- and post mobilization training to assist them in performing detainee operations.

(2) **Standard:** Training on standard of treatment for detainees in OPERATION ENDURING FREEDOM (OEF): Guidance was provided stating that members of the Taliban militia and members of Al Qaida under the control of U.S. Forces would be treated humanely and, to the extent appropriate and consistent with military necessity, in a manner consistent with the principles of the Geneva Conventions of 1949. The DAIG has therefore used the provisions of the Geneva Conventions as a benchmark against which to measure the treatment provided to detainees by U.S. Forces to determine if detainees were treated humanely and if the corresponding training was consistent with this obligation. The use of these standards as benchmarks does not state or imply a position for the United States or U.S. Army on the legal status of its operations in OEF.

Chairman, Joint Chiefs of Staff (CJCS) Message dated 211933Z JAN 02, provides the determination regarding the humane treatment of Al Qaida and Taliban detainees. Convention Relative to the Treatment of Prisoners of War of August 12, 1949 (GPW) is the international treaty that governs the treatment of prisoners of war, and Geneva Convention Relative to the Protection of Civilian Persons in Time of War (GC), August 12, 1949, is the international treaty that governs the treatment of civilian persons in time of war.

As the guidance did not define "humane treatment" but did state that the U.S. would treat members of the Taliban militia and Al Qaida in a manner consistent with the Geneva Conventions, the DAIG determined that it would use Common Article 3 of the GCs as its floor measure of humane treatment and corresponding training, but would also include provisions of the Geneva Convention on the Treatment of Prisoners of War (GPW) and Geneva Convention Relative to the Protection of Civilian Persons in Time of War (GC) as other relevant indicia of "humane treatment." The use of this standard does not state or imply a position for the United States or U.S. Army on the legal status of its operations in OEF.

Standard of treatment for detainees in OPERATION IRAQI FREEDOM (OIF): OIF was an international armed conflict and therefore the provisions of the Geneva Conventions applied.

The minimum treatment provided by Common Article 3 of the Geneva Conventions is: (1) No adverse distinction based upon race, religion, sex, etc.; (2) No violence to life or person; (3) No taking hostages; (4) No degrading treatment; (5) No passing of sentences in absence of fair trial, and; (6) The wounded and sick must be cared for.

The specific language in the CJCS Message for OEF and the GPW/GC and H.IV follows:

CJCS Message dated 211933Z JAN 02, "Paragraph 3. The combatant commanders shall, in detaining Al Qaida and Taliban individuals under the control of the Department of Defense, treat them humanely and, to the extent appropriate and consistent with military necessity, in a manner consistent with the principles of the Geneva Conventions of 1949."

GPW/GC, Article 3 (Common Article 3) – "In the case of armed conflict not of an international character occurring in the territory of one of the High Contracting Parties, each party to the conflict shall be bound to apply, as a minimum, the following provisions:

1. Persons taking no active part in the hostilities, including members of armed forces who have laid down their arms and those placed hors de combat by sickness, wounds, detention, or any other cause, shall in all circumstances be treated humanely, without any adverse distinction founded on race, color, religion or faith, sex, birth or wealth, or any other similar criteria.

To this end the following acts are and shall remain prohibited at any time and in any place whatsoever with respect to the above-mentioned persons:

(a) Violence to life and person, in particular murder of all kinds, mutilation, cruel treatment and torture;
 (b) Taking of hostages;
 (c) Outrages upon personal dignity, in particular, humiliating and degrading treatment;
 (d) The passing of sentences and the carrying out of executions without previous judgment pronounced by a regularly constituted court affording all the judicial guarantees which are recognized as indispensable by civilized peoples.

2. The wounded and sick shall be collected and cared for. An impartial humanitarian body, such as the International Committee of the Red Cross, may offer its services to the Parties to the conflict. The Parties to the conflict should further endeavour to bring into force, by means of special agreements, all or part of the other provisions of the present Convention. The application of the preceding provisions shall not affect the legal status of the Parties to the conflict."

GPW Article 127 and GC Article 144 establish a requirement for signatories to the treaties to train their military on the obligations under the conventions. The specific standards follow:

"GC Article 127 – The High Contracting Parties undertake, in time of peace as in time of war, to disseminate the text of the present Convention as widely as possible in their respective countries, and, in particular, to include the study thereof in their programmes of military and, if possible, civil instruction, so that the principles thereof may become known to all their armed forces and to the entire population. Any military or other authorities, who in time of war assume responsibilities in respect of prisoners of war, must possess the text of the Convention and be specially instructed as to its provisions.

GC Article 144 – The High Contracting Parties undertake, in time of peace as in time of war, to disseminate the text of the present Convention as widely as possible in their respective countries, and, in particular, to include the study thereof in their programmes of military and, if

possible, civil instruction, so that the principles thereof may become known to the entire population. Any civilian, military, police or other authorities, who in time of war assume responsibilities in respect of protected persons, must possess the text of the Convention and be specially instructed as to its provisions."

Army Regulation 350-1, Army Training and Education, 9 April 2003, Chapter 1, paragraph 1-8, subparagraph 2d, establishes Home Station Training priorities for all Army personnel. Chapter 4, paragraph 4-5, outlines training requirements for Common Military Training for all Army personnel. Appendix G, paragraph G-1, subparagraph(s) b-c, outlines an overview of the Common Military Training program. Table G-1, provides examples of military training requirements in units. The specific language in the regulation follows:

"2d. Training will be the top priority for all commanders - To prepare individuals and units for immediate deployment and organizations for employment in support of operational missions, Army individual, collective, and modernization training provides for—

(1) Unit training that develops the critical components of combat readiness. These include development of—

(a) Soldiers, leaders, and units capable of deploying, executing assigned missions, and redeploying.

(b) Effective combined arms teams consisting of integrated combat, combat support (CS), combat service support, and close air support.

(2) An individual training system that—

(a) Produces initial entry soldiers who are highly motivated, disciplined, physically fit, and skilled in common soldier and basic branch tasks.

(b) Provides a training base of Army schools that prepares soldiers and DA civilian employees for more complex duties and progressively higher positions of responsibility.

(c) Produces soldiers capable of performing military occupational specialty (MOS), Area of Concentration (AOC), additional skill identifier (ASI), skill identifier (SI), special qualification identifier (SQI), and language identification code (LIC) tasks. Prior service Reserve Component (RC) and Active Army personnel receive required training through The Army Training System courses (TATS-C) or proponent-approved formal on-the-job training (OJT). TATS courses are designed to train the same MOS, AOC, skill level, SQI, ASI, LIC, and SI within the Army. TATS also includes MOS qualification (reclassification), Army leadership, and professional development courses.

(d) Provides reclassification training for changing an enlisted or warrant officer MOS, or to qualify an officer in a new branch. Reclassification training will be accomplished in accordance with Army Regulation (AR) 140-1, AR 614-200, and AR 611-1.

(3) Active Army, Department of the Army civilians, and RC forces able to mobilize rapidly, deploy, and perform their operational missions.

(4) Standardization of tasks and performance standards across the Army. Units and soldiers performing the same tasks will be trained to the same standard.

(5) Efficient and effective internal and external evaluation procedures that improve training, sustain required readiness levels, and control or reduce costs.

(6) A training system that supports peacetime requirements and transitions smoothly at mobilization."

"4-5. Common military training and common task training -

(a) CMT program identifies common military training requirements for unit commanders' planning and training programs because of their importance to individual soldier and unit readiness. Common military training is required for all leaders and soldiers at specific organizational levels, and proficiency in those subject areas is necessary, regardless of branch or career field or rank or grade. Common military training requirements are limited to those subject areas directed by law and HQDA. The HQDA, DCS, G-3, maintains centralized control over CMT directed training requirements and validates these requirements biennially."

"G-1. Overview -

(b) MACOM commanders have a degree of latitude in adding to or emphasizing certain training requirements; however, care should be taken not to degrade battle-focused training.

(c) Successful CMT programs are measured by performance to standard and not adherence to rosters or hours scheduled."

"Table G-1, Common military training requirements in units -

Weapons Qualification, Civil disturbance, Antiterrorism and Force Protection, Code of Conduct/ SERE, Law of War..."

Field Manual (FM) 3-19.4, Military Police Leaders' Handbook, 4 March 2002, Chapter 1, paragraph 1-4, outlines the 5 Military Police Functional Areas. The specific language in the field manual follows:

"b. Military Police Functional Areas -

(1-4) with the old battlefield missions, the term "operations" was used extensively and carried too broad of a meaning. To clarify the specific tasks of the MP, the battlefield missions have been redefined into the following five functional areas:

- MMS (Maneuver and Mobility Support)
- AS (Area Security)
- I/R (Internment and Resettlement)
- L&O (Law and Order)
- PIO (Police Intelligence Operations)"

FORSCOM Regulation 500-3-1, FORSCOM MOBILIZATION and DEPLOYMENT PLANNING SYSTEM (FORMDEPS), Volume 1, FORSCOM MOBILIZATION PLAN (FMP), 15 April 1998, Annex O, paragraph 2.4.4, defines additional training requirements at mobilization sites. The specific language in the regulation follows:

"Mobilized Unit Commanders --

(2) Commanders will additionally concentrate on training on soldier/leader skills. This training will be designed to make best use of time available after unit equipment is shipped and will include the following as a minimum:

(a) Physical fitness. Its importance cannot be overstated. Training should be conducted in accordance with AR 350-15 and FM 21-20.

(b) Common Task Test. Testing is most often practiced in a sterile, "round robin" setting using the tasks, conditions and standards provided in the STP 21-series Soldier's Manual of Common Tasks. Testing should include an element of tactical realism to cause soldiers, as members of teams, crews, sections, and squads to think and react instinctively.

(c) The NBC Training. The following tasks are of paramount importance:

1. Recognize/react to chemical/ biological hazards.
2. Don Mission-Oriented Protection Posture (MOPP) gear.
3. Detect and identify chemical agents using M8/M9 paper.
4. Administer nerve agent antidote to self (self aid) and to a nerve agent casualty (buddy-aid).
5. Decon skin and personal equipment using the M258A1 decon kit, the M291 skin decon kit, and the M295 equipment decon kit.
6. Drink from a canteen while wearing a protective mask.
7. Maintain and use the M40 series protective mask with hood.

(d) Care and maintenance of CTA 50-900 series and MTO&E equipment.

(e) Force protection to include terrorist threat. (See Appendix 1)

(f) Hazards and survival.

(g) Individual and crew served weapons proficiency.

(h) First Aid - Combat Lifesavers.

(i) Rules of Engagement.

(j) Personal hygiene.

(k) Threat and allied equipment recognition

(l) An orientation on the area of probable operations to include language, customs, courtesies, etc."

v. Finding 22:

(1) Finding: To offset the shortage of interrogators, contractors were employed, however, 35% (11 of 31) of contract interrogators lacked formal training in military interrogation policies and techniques.

(2) Standard: Army Regulation (AR) 190-8, Enemy Prisoners of War, Retained Personnel, Civilian Internees and Other Detainees, 1 October 1997, Chapter 2, paragraph 2-1.

provides the regulatory guidance for interrogation of detainees in a combat zone. This regulation is a multi-service regulation implementing DOD Directive 2310.1 and incorporates Army Regulation 190-8 and 190-57 and SECNAV Instruction 3461.3, and Air Force Joint Instruction 31-304 and outlines policies, procedures, and responsibilities for treatment of enemy prisoners of war (EPW), retained personnel (RP), civilian internees (CI), and other detainees (OD) and implements international law for all military operations. The specific language in the regulation follows:

"(d) Prisoners may be interrogated in the combat zone. The use of physical or mental torture or any coercion to compel prisoners to provide information is prohibited. Prisoners may voluntarily cooperate with PSYOP personnel in the development, evaluation, or dissemination of PSYOP messages or products. Prisoners may not be threatened, insulted, or exposed to unpleasant or disparate treatment of any kind because of their refusal to answer questions. Interrogations will normally be performed by intelligence or counterintelligence personnel."

Field Manual (FM) 27-10, The Law of Land Warfare, 18 July 1956 (change 1, 15 July 1976), Chapter 3, section IV, paragraph 93, describes guidelines for the questioning of EPWs. The specific language in the field manual follows:

"No physical or mental torture, nor any other form of coercion, may be inflicted on prisoners of war to secure from them information of any kind whatever. Prisoners of war who refuse to answer may not be threatened, insulted, or exposed to unpleasant or disadvantageous treatment of any kind."

FM 34-52, Intelligence Interrogation, 28 September 1992, Chapter 1, defines and explains the purpose of interrogation. The specific language in the field manual follows:

"Interrogation is the process of questioning a source to obtain the maximum amount of usable information. The goal of any interrogation is to obtain reliable information in a lawful manner, in a minimum amount of time, and to satisfy intelligence requirements of any echelon of command.

A good interrogation produces needed information, which is timely, complete, clear, and accurate."

CJTF-7 C2 Interrogation Cell Statement of Work, CACI International, Inc., 14 August 2003, Paragraphs 7 (c) and 9 (c) describe the requirements for contract interrogators hired to man the theater and division interrogations support cells in OIF. The specific language in the statement of work follows:

"Identified interrogators should be the civilian equivalent to one of the following: 97E, 351E, Strategic Debriefing or an individual with a similar skill set, and US Citizens with a Secret clearance."

w. Finding 23:

(1) Finding: Interviewed leaders and Soldiers indicated their Law of War refresher training was not detailed enough to sustain their knowledge obtained during initial and advanced training.

(2) Standard: Training on standard of treatment for detainees in OPERATION ENDURING FREEDOM (OEF): Guidance was provided stating that members of the Taliban militia and members of Al Qaida under the control of U.S. Forces would be treated humanely and, to the extent appropriate and consistent with military necessity, in a manner consistent with the principles of the Geneva Conventions of 1949. The DAIG has therefore used the provisions of the Geneva Conventions as a benchmark against which to measure the treatment provided to detainees by U.S. Forces to determine if detainees were treated humanely and if the corresponding training was consistent with this obligation. The use of these standards as benchmarks does not state or imply a position for the United States or U.S. Army on the legal status of its operations in OEF.

Chairman, Joint Chiefs of Staff (CJCS) Message dated 211933Z JAN 02, provides the determination regarding the humane treatment of Al Qaida and Taliban detainees. Convention Relative to the Treatment of Prisoners of War of August 12, 1949 (GPW) is the international treaty that governs the treatment of prisoners of war, and Geneva Convention Relative to the Protection of Civilian Persons in Time of War (GC), August 12, 1949, is the international treaty that governs the treatment of civilian persons in time of war.

As the guidance did not define "humane treatment" but did state that the U.S. would treat members of the Taliban militia and Al Qaida in a manner consistent with the Geneva Conventions, the DAIG determined that it would use Common Article 3 of the GCs as its floor measure of humane treatment and corresponding training, but would also include provisions of the Geneva Convention on the Treatment of Prisoners of War (GPW) and Geneva Convention Relative to the Protection of Civilian Persons in Time of War (GC) as other relevant indicia of "humane treatment." The use of this standard does not state or imply a position for the United States or U.S. Army on the legal status of its operations in OEF.

Standard of treatment for detainees in OPERATION IRAQI FREEDOM (OIF): OIF was an international armed conflict and therefore the provisions of the Geneva Conventions applied.

The minimum treatment provided by Common Article 3 of the Geneva Conventions is: (1) No adverse distinction based upon race, religion, sex, etc.; (2) No violence to life or person; (3) No taking hostages; (4) No degrading treatment; (5) No passing of sentences in absence of fair trial, and; (6) The wounded and sick must be cared for.

The specific language in the CJCS Message for OEF and the GPW/GC and H.IV follows:

CJCS Message dated 211933Z JAN 02, "Paragraph 3. The combatant commanders shall, in detaining Al Qaida and Taliban individuals under the control of the Department of Defense, treat them humanely and, to the extent appropriate and consistent with military necessity, in a manner consistent with the principles of the Geneva Conventions of 1949."

GPW/GC, Article 3 (Common Article 3) – "In the case of armed conflict not of an international character occurring in the territory of one of the High Contracting Parties, each party to the conflict shall be bound to apply, as a minimum, the following provisions:

1. Persons taking no active part in the hostilities, including members of armed forces who have laid down their arms and those placed hors de combat by sickness, wounds, detention, or any other cause, shall in all circumstances be treated humanely, without any

adverse distinction founded on race, color, religion or faith, sex, birth or wealth, or any other similar criteria.

To this end the following acts are and shall remain prohibited at any time and in any place whatsoever with respect to the above-mentioned persons:

- (a) Violence to life and person, in particular murder of all kinds, mutilation, cruel treatment and torture;
- (b) Taking of hostages;
- (c) Outrages upon personal dignity, in particular, humiliating and degrading treatment;
- (d) The passing of sentences and the carrying out of executions without previous judgment pronounced by a regularly constituted court affording all the judicial guarantees which are recognized as indispensable by civilized peoples.

2. The wounded and sick shall be collected and cared for. An impartial humanitarian body, such as the International Committee of the Red Cross, may offer its services to the Parties to the conflict. The Parties to the conflict should further endeavour to bring into force, by means of special agreements, all or part of the other provisions of the present Convention. The application of the preceding provisions shall not affect the legal status of the Parties to the conflict."

GPW Article 127 and GC Article 144 establish a requirement for signatories to the treaties to train their military on the obligations under the conventions. The specific standards follow:

"GC Article 127 – The High Contracting Parties undertake, in time of peace as in time of war, to disseminate the text of the present Convention as widely as possible in their respective countries, and, in particular, to include the study thereof in their programmes of military and, if possible, civil instruction, so that the principles thereof may become known to all their armed forces and to the entire population. Any military or other authorities, who in time of war assume responsibilities in respect of prisoners of war, must possess the text of the Convention and be specially instructed as to its provisions.

GC Article 144 – The High Contracting Parties undertake, in time of peace as in time of war, to disseminate the text of the present Convention as widely as possible in their respective countries, and, in particular, to include the study thereof in their programmes of military and, if possible, civil instruction, so that the principles thereof may become known to the entire population. Any civilian, military, police or other authorities, who in time of war assume responsibilities in respect of protected persons, must possess the text of the Convention and be specially instructed as to its provisions."

Department of Defense Directive (DoDD) 2310.1, DoD Program for Enemy Prisoners of War (EPOW) and Other Detainees, 18 August 1994, Section 3, provides DoD policy for training on the Geneva Conventions. The specific language in the directive follows:

"3. Policy. It is DoD policy that:

3.1. The U.S. Military Services shall comply with the principles, spirit, and intent of the international law of war, both customary and codified, to include the Geneva Conventions (references (b) through (e)).

3.2. The U.S. Military Services shall be given the necessary training to ensure they have knowledge of their obligations under the Geneva Conventions (references (b) through (e)) and as required by DoD Directive 5100.77 (reference (f)) before an assignment to a foreign area where capture or detention of enemy personnel is possible.

3.3. Captured or detained personnel shall be accorded an appropriate legal status under international law. Persons captured or detained may be transferred to or from the care, custody, and control of the U.S. Military Services only on approval of the Assistant Secretary of Defense for International Security Affairs (ASD(ISA)) and as authorized by the Geneva Conventions Relative to the Treatment of Prisoners of War and for the Protection of Civilian Persons in Time of War (references (d) and (e)).

3.4. Persons captured or detained by the U.S. Military Services shall normally be handed over for safeguarding to U.S. Army Military Police, or to detainee collecting points or other holding facilities and installations operated by U.S. Army Military Police as soon as practical. Detainees may be interviewed for intelligence collection purposes at facilities and installations operated by U.S. Army Military Police."

Department of Defense Directive (DoDD) 5100.77, DoD Law of War Program, 9 December 1998, Section 5.5, provides DoD policy for Law of War policy and training. The specific language in the directive follows:

"5.5. The Secretaries of the Military Departments shall develop internal policies and procedures consistent with this Directive in support of the DoD Law of War Program to:

5.5.1. Provide directives, publications, instructions, and training so that the principles and rules of the law of war will be known to members of their respective Departments, the extent of such knowledge to be commensurate with each individual's duties and responsibilities.

5.5.2. Ensure that programs are implemented in their respective Military Departments to prevent violations of the law of war, emphasizing any types of violations that have been reported under this Directive.

5.5.3. Provide for the prompt reporting and investigation of reportable incidents committed by or against members of their respective Military Departments, or persons accompanying them, in accordance with directives issued under paragraph 5.8.4., below.

5.5.4. Where appropriate, provide for disposition, under the Uniform Code of Military Justice (reference (i)), of cases involving alleged violations of the law of war DODD 5100.77, December 9, 1998 4 by members of their respective Military Departments who are subject to court-martial jurisdiction.

5.5.5. Provide for the central collection of reports and investigations of reportable incidents alleged to have been committed by or against members of their respective Military Departments, or persons accompanying them.

5.5.6. Ensure that all reports of reportable incidents are forwarded to the Secretary of the Army in his or her capacity as the DoD Executive Agent under subsection 5.6., below."

Army Regulation (AR) 350-1, Army Training and Education, 9 April 2003, Section 4-14, sets the guidelines for Law of War training. The specific language in the regulation follows:

"4-14. Law of war training

a. Soldiers and leaders require law of war training throughout their military careers commensurate with their duties and responsibilities. Prescribed subject matter for training at the following levels is specified in paras 4-14b-d of this regulation.

(1) Level A training is conducted during IET for all enlisted personnel and during basic courses of instruction for all warrant officers and officers.

(2) Level B training is conducted in units for officers, warrant officers, NCOs and enlisted personnel commensurate with the missions of the unit.

(3) Level C training is conducted in The Army School System (TASS).

b. Level A training provides the minimum knowledge required for all members of the Army. The following basic law of war rules (referred to as "The Soldier's Rules," which stresses the importance of compliance with the law of war) will be taught during level A training:

(1) Soldiers fight only enemy combatants.

(2) Soldiers do not harm enemies who surrender. They disarm them and turn them over to their superior.

(3) Soldiers do not kill or torture enemy prisoners of war.

(4) Soldiers collect and care for the wounded, whether friend or foe.

(5) Soldiers do not attack medical personnel, facilities, or equipment.

(6) Soldiers destroy no more than the mission requires.

(7) Soldiers treat civilians humanely.

(8) Soldiers do not steal. Soldiers respect private property and possessions.

(9) Soldiers should do their best to prevent violations of the law of war.

(10) Soldiers report all violations of the law of war to their superior.

c. Unit commanders will plan and execute level B law-of-war training based on the following:

(1) Training should reinforce the principles set forth in The Soldier's Rules.

(2) Training will be designed around current missions and contingency plans (including anticipated geographical areas of deployment or rules of engagement).

(3) Training will be integrated into unit training activities, field training exercises and unit external evaluations (EXEVAL). Maximum combat realism will be applied to tactical exercises consistent with good safety practices.

d. Army schools will tailor law of war training to the tasks taught in those schools. Level C training will emphasize officer, warrant officer, and NCO responsibilities for:

(1) Their performance of duties in accordance with the law of war obligations of the United States.

(2) Law of war issues in command planning and execution of combat operations.

(3) Measures for the reporting of suspected or alleged war crimes committed by or against U.S. or allied personnel."

Appendix F

Abbreviations and Acronyms

AAR	After Action Review
ABN	Airborne
AC	Active Component
AD	Armored Division
ANCOC	Advanced Noncommissioned Officer Course
AOC	Area of Concentration
AOR	Area of Responsibility
AR	Army Regulation
ARNG	Army National Guard
ASD(ISA)	Assistant Secretary of Defense for International Security Affairs
ASD(SO/LIC)	Assistant Secretary of Defense for Special Operations and Low Intensity Conflict
ASI	Additional Skill Identifier
BATS	Biometric Assessment Tool Set
BIAP	Baghdad International Airport
BDE	Brigade
BN	Battalion
CAT	UN Convention Against Torture and Other Cruel, Inhuman or Degrading Treatment or Punishment
CAV	Cavalry
CCC	Captain's Career Course
C&E	Collection and Exploitation
CENTCOM	U.S. Central Command

CFLCC	Combined Forces Land Component Command
CHA	Corps Holding Area
CI	Civilian Detainee
CID	Criminal Investigation Division
CIF	Central Issue Facility
C-IMINT	Counter-Imagery Intelligence
CJCS	Chairman of the Joint Chiefs of Staff
CJTF-7	Combined Joint Task Force-7
CJTF-180	Combined Joint Task Force-180
CMT	Common Military Training
Co	Company
COE HI	Contemporary Operational Environment High Intensity
COMMZ	Communication Zone
COMSEC	Communications Security
CONUS	Continental United States
CP	Collecting Points
CPA	Coalition Provisional Authority
C-SIGINT	Counter-Signals Intelligence
CSM	Command Sergeant Major
CTC	Combat Training Center
CTT	Common Task Training
DAIG	Department of the Army Inspectors General
DD FORM	Department of Defense Form
DoD	Department of Defense
DOTMLPF	Doctrine, Organization, Training, Materiel, Leadership, Personnel, and Facilities

DRB	Detainee Release Board
DSA	Division Support Area
EC	Enemy Combatant
EPW	Enemy Prisoners of War
FDU	Force Design Update
FM	Field Manual
FORSCOM	Forces Command
FSB	Forward Support Battalion
FY	Fiscal Year
GC	Geneva Convention Relative to the Protection of Civilian Persons in Time of War
GPW	Geneva Convention Relative to the Treatment of Prisoners of War
HHD	Headquarters and Headquarters Detachment
HMMWV	High Mobility Multipurpose Wheeled Vehicle
HRD	High Risk Detainee
HUMINT	Human Intelligence
IBOS	Intelligence Battlefield Operating System
ICRC	International Committee of the Red Cross
ID	Infantry Division
IED	Improvised Explosive Device
IET	Initial Entry Training
IG	Inspectors General
ILO	In Lieu Of
IMINT	Imagery Intelligence
IN	Infantry
I/R	Internment/Resettlement

JABS	Joint Automated Booking System
JFLCC	Joint Force Land Component Commander
JIDC	Joint Interrogation and Debriefing Center
JIF	Joint Interrogation Facility
JRTC	Joint Readiness Training Center
JTF	Joint Task Force
LLEC	Low Level Enemy Combatant
LMTV	Light Medium Tactical Vehicle
METT-TC	Mission, Enemy, Terrain and Weather, Time, Troops Available, and Civilian
MG	Major General
MI	Military Intelligence
MICCC	Military Intelligence Captain Career Course
MI-CSB	Military Intelligence Corps Support Battalion
MILES	Multi-Integrated Laser Engagement System
MIOBC	Military Intelligence Officer Basic Course
MOS	Military Occupational Specialty
MP	Military Police
MRE	Meal Ready to Eat
MRX	Mission Rehearsal Exercise
MTOE	Modified Tables of Organization and Equipment
MTT	Mobile Training Team
MUA	Maneuver Unit of Action
MWR	Morale, Welfare, and Recreation
NCO	Noncommissioned Officer
NCOIC	Noncommissioned Officer in Charge

NDRC	National Detainee Reporting Center
NPWIC	National Prisoner of War Information Center
NTC	National Training Center
OCONUS	Outside the Continental United States
OD	Other Detainee
OEF	OPERATION ENDURING FREEDOM
OGA	Other Government Organization
OIF	OPERATION IRAQI FREEDOM
OMT	Operations Management Team
OPMG	Office of the Provost Marshal General
OTJAG	Office of The Judge Advocate General
OTSG	Office of the Surgeon General
PLDC	Primary Leadership Development Course
PME	Professional Military Education
POC	Point of Contact
POI	Program of Instruction
PUC	Person Under U.S. Control
PWIC	Prisoner of War Information Center
PX	Post Exchange
QDF	Quadrennial Defense Review
RC	Reserve Component
RCF	Regional Correctional Facility
ROE	Rules of Engagement
RP	Retained Person
R&R	Rest and Recuperation
RSTA UA	Reconnaissance, Surveillance, and Target

	Acquisition Unit of Action
SAEDA	Subversion & Espionage Directed Against U.S. Army & Deliberate Security Violation
SASO	Stability and Support Operation
SF	Standard Form
SFC	Sergeant First Class
SIMEX	Simulation Exercise (SIMEX)
SINGARS	Single Channel Ground/Air Radio System
SOP	Standing Operating Procedure
SOW	Statement of Work
SRC	Soldier Readiness Checks
SSG	Staff Sergeant
STX	Situational Training Exercises
TAA	Total Army Analysis
TACSOP	Tactical Standing Operating Procedure
TDA	Table of Distribution and Allowance
TDRC	Theater Detainee Reporting Center
THT	Tactical Human Intelligence Team
TIF	Theater Interrogation Center
TOC	Tactical Operations Center
TOE	Table of Organization and Equipment
TRADOC	Training and Doctrine Command
TTP	Tactics, Techniques, and Procedures
UA	Unit of Action
UCMJ	Uniform Code of Military Justice
UEX	Unit of Employment x

UEy	Unit of Employment y
USACIC	U.S. Army Criminal Investigation Command
USAIC	U.S. Army Intelligence Center
USAICS	U.S. Army Intelligence Center and School
USAMANSCE	U.S. Army Maneuver Support Center
USAMPS	U.S. Army Military Police School
USAR	U.S. Army Reserve
USASOC	U.S. Army Special Operations Command
USDB	U.S. Military Disciplinary Barracks
WOAC	Warrant Officer Advanced Course
WOCS	Warrant Officer Candidate School
2X	Human Intelligence / Counterintelligence Personnel
31B	Enlisted Military Occupational Specialty - Military Police
31E	Enlisted Military Occupational Specialty - Internment/Resettlement
97B	Enlisted Military Occupational Specialty - Counterintelligence Personnel
97E	Enlisted Military Occupational Specialty - Human Intelligence (HUMINT) Collector
351E	Warrant Officer Human Intelligence Collection Technician

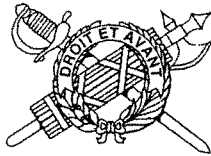

Chairman WARNER. Thank you very much. I am impressed by your report, General. It seems to me to track very carefully within the prescribed guidelines issued by the Secretary.

If I might inform our witnesses and all others present, there will be three votes stacked at 11 o'clock. Furthermore, my distinguished colleague the ranking member has to be on the floor at 10:30 to address the issues in one or more of those votes. So it is the intention, I will announce it now, of the chairman to continue this hearing to approximately 11:15 and then, if Senators are unable to come, I will entertain with the ranking member the option of keeping this hearing open. We will almost take an hour hiatus. So I am certain those who are monitoring the hearing will let us know in that event.

Now I will yield to the distinguished ranking member and then follow him, and then we will have a first round of questions with those members who are here.

I also advise the witnesses that unexpectedly the leadership announced this morning that all Senators were invited to a briefing on the 9–11 report. Consequently, there are a number of conflicts that made it unable for Senators to attend this morning.

Senator Levin.

Senator LEVIN. Mr. Chairman, thank you for yielding to me. I appreciate that very much.

General Mikolashek, you have testified that your inspection did not find systemic problems in doctrine and training. But General Abizaid told us on May 19 that he had reviewed the preliminary findings of the IG's inspection, and at that time he told us that, "Our doctrine is not right. It is just not right. There are so many things out there that are not right in the way that we operate for this war. This is a doctrinal problem of understanding what do the MPs do, what do the military intelligence guys do, and how do they come together in the right way. This doctrinal issue has to be fixed if we are ever going to get our intelligence right to fight this war and beat this enemy."¹

I am just wondering how that statement of his squares with your testimony here.

General MIKOLASHEK. Sir, it squares perfectly. Let me just emphasize that what we found was that none of those—well, we did find doctrinal problems, and they are laid out in the report. But as we went back, we looked at each of those cases of abuse, what caused them: was it a doctrinal problem, was it a problem with our training, our organization, and when the leadership failed was it a result of a large-scale widespread leadership failure in each of those specific cases? In that kind of autopsy, we found that, while there were problems and there are problems in our doctrine, our organization, how we train and prepare soldiers for this kind of operation, we found no direct linkage to each of those cases of abuse that we reviewed.

We do make a considerable number of recommendations regarding our doctrine that specifically addresses the points that you addressed regarding the MI and MP relationship, the doctrinal and

¹ Senate Armed Services Committee, "Hearing to Continue to Receive Testimony on Allegations of Mistreatment of Iraqi Prisoners." Wednesday, May 19, 2004, 8:30 a.m.

organizational structures for our interrogation facilities, and how those interview approach techniques should be applied and safeguards applied to make sure they are done in a safe manner.

We also again addressed the training issues.

Senator LEVIN. Thank you.

The February 2004 ICRC report that has been published—it is on the Internet—says that several military intelligence officers confirmed to the ICRC that it was part of the military intelligence process to hold a person deprived of his liberty naked and in a completely dark and empty cell for a prolonged period, to use inhumane and degrading treatment, including physical and psychological coercion. Then they went into details of some ill-treatment and abuses.

Then they said: “These methods of physical and psychological coercion were used by the military intelligence in a systematic way to gain confessions and extract information or other forms of cooperation from persons who had been arrested in connection with suspected security offenses or deemed to have an intelligence value.”

Did you read that report?

General MIKOLASHEK. Yes, sir.

Senator LEVIN. Do you disagree with those conclusions?

General MIKOLASHEK. Sir, if those occurred as they described—and of course those matters are under investigation by the Procedure 15 report that will determine those kinds of activities and determine the outcome of those. But if you assume for a minute that they did occur, that still they were not the result of an approved technique, based on our investigation. They still would have been an individual breakdown in following orders, following the procedures that had been published, and a failure of the leaders who should have known that those kinds of incidents are wrong and should have been stopped.

Senator LEVIN. That makes it much more systematic.

General MIKOLASHEK. Yes, sir.

Senator LEVIN. You make a distinction between systematic and systemic.

General MIKOLASHEK. Yes, sir, we do make a difference between systematic and systemic.

Senator LEVIN. Thank you.

Did you review who received the November ICRC report?

General MIKOLASHEK. Sir, we did not, and I know there are other people looking at the audit trail on how that report was provided to the command and others.

Senator LEVIN. Now, you made some findings relative to the subordination of MP custody and control mission to the need for intelligence and indicated that this need for intelligence can create settings in which unsanctioned behavior, including detainee abuse, could occur and that failure of the MP and the MI, the intelligence personnel, to understand each others' specific missions and duties could undermine the effectiveness of safeguards associated with interrogation techniques and procedures.

General Taguba raised in his report concerns about the recommendation of General Miller that an MP force be subordinate to the commander at the Joint Interrogation Center. General Taguba

recommended that the military police should not be involved with setting "favorable conditions" for subsequent interviews.

I am wondering, General, whether you agree with General Taguba's recommendation regarding subordinating MPs to the intelligence command and whether or not the policy of subordinating MPs, military police, to the military intelligence's need for intelligence contributed at least indirectly the prisoner abuse by creating a setting in which unsanctioned behavior, including detainee abuse, could occur.

General MIKOLASHEK. Sir, that strikes at the heart of one of our recommendations regarding the MI-MP relationship. To answer perhaps your last question first, our effort to look at that particular process was an effort to ensure that we put our doctrine in place, that we provide our commanders how to organize these facilities, that we provide the right kind of direction, guidance, and training to both our MPs and our MIs, MI personnel, to prevent the kind of situation that may occur.

While we did find no direct relationship to any of those to an abuse situation, because the cases we looked at, the most notable ones in Abu Ghraib, were outside the confines of interrogations. I would rather defer to the other investigations that will look at the environment, because we were not able to interview the people directly involved in that or we decided not to interview them because of the ongoing criminal proceedings.

Senator LEVIN. Could there have been at least an indirect connection?

General MIKOLASHEK. But our—

Senator LEVIN. Could there be an indirect contribution of the failure of the Army doctrine to clearly address the role of military police in the interrogation process? That absence of doctrine, could that have indirectly contributed to the problem?

General MIKOLASHEK. In that case I do not think so, sir, because again what I know and what we looked at from Abu Ghraib, it was outside the bounds of interrogation. But it does demand that we look at how the MPs are trained and prepared and how the MI personnel are trained and prepared. They need to acknowledge and be aware of other people's roles and responsibilities. We need to provide the guidance as to how they organize these facilities to prevent those things in the future or, if that were the case, that environment did ensue, that we would find a way to help prevent that.

Senator LEVIN. Thank you.

I will save the balance of my questions

Mr. BROWNLEE. Could I add one thing to that, sir, just about doctrine in general? We do have doctrine, and we go to war with that doctrine. These are guiding principles. But as you well know, war is a fluid, dynamic situation. Things change; the environment changes. We went from a rather linear kind of battlefield to an urban insurgency. As the environment changed, the nature of the detainees changed. We did not have large bodies of compliant soldiers who were coming in with their hands up. We were detaining individuals who were suspected of perhaps acting against the coalition. We in some cases had hardened criminals in these groups.

It was a different environment, and in different environments we educate our soldiers, leaders, and commanders to adapt to these

environments. The doctrine will catch up with this, and it is already doing that. But the same is true of our organization and our training. Much of this stems from these changing environments. But that is the reason we train our leaders and soldiers to be adaptable and not to follow in a rote sense a plan or even a doctrine.

Chairman WARNER. Chief, you wish to reply. Go right ahead.

General SCHOOMAKER. Sir, I would just like to add something, and I would ask General Mikolashek to confirm this. But it is in the report if you read it, there is a difference in the MP doctrine that articulates what the MP's role is in this process. If you go to the military intelligence doctrine published, the manual, you will find a nuance in there that indicates that the MPs are part of the process. This is one of his findings and one of the corrections that we need to make, and that is the reconciliation of this Joint Intelligence Center operation so that we remove the confusion that may have existed in this.

I would just ask, is that accurate?

General MIKOLASHEK. Sir, that is exactly right.

Senator LEVIN. That is doctrinal.

General SCHOOMAKER. Exactly.

Mr. BROWNLEE. But even with that, sir, it is important to add, even if there was a nuance between the two field manuals in the doctrines, that would not have given anyone the notion that they had approval to engage in some of these abusive acts.

General SCHOOMAKER. I did not mean to indicate it was an excuse for anything. Still the bottom line is the actions that we are most concerned about are breakdowns in discipline and people doing things that fundamentally they knew to be wrong.

Senator LEVIN. Thank you. Thank you very much.

Chairman WARNER. Thank you, Senator Levin.

Again, Secretary Brownlee, you touched on the fact that our forces in the rapid advancement up through and into Baghdad were encountering a lot of unanticipated factors, among them it is my recollection Saddam Hussein opened the doors of all the prisons.

Mr. BROWNLEE. Yes, sir.

Chairman WARNER. At least some, I have heard, 60,000—

Mr. BROWNLEE. Yes, sir. I have heard up to 70,000, sir.

Chairman WARNER. 70,000 individuals—

Mr. BROWNLEE. Criminals.

Chairman WARNER.—just out into the nation, across the nation again. Those are individuals that through some means or for some reason had been incarcerated for actions contrary to whatever the law was in Iraq. That was an enormously complicating factor for our forces moving in.

Mr. BROWNLEE. Yes, sir.

Chairman WARNER. And dangerous to them.

Mr. BROWNLEE. Probably led to a great deal of the looting that occurred.

Chairman WARNER. I share that view.

Mr. Secretary, the United States quite justifiably has refused to enter into international treaties that would subject U.S. military personnel to an international court of criminal justice. However, it

is imperative that the U.S. demonstrate to the world a firm resolve to vigorously investigate potential criminal actions by members of the Armed Forces and that appropriate actions are taken under the United States Uniform Code of Military Justice.

Are you satisfied the Army is thoroughly investigating all allegations of potential criminal activity?

Mr. BROWNLEE. Yes, sir. In fact, I have a periodic update on that. I need to be careful here that I do not indicate in any way to influence it or cause command influence. But I am convinced that the allegations and incidents of abuse that we know about are being thoroughly investigated and will be pursued where appropriate with legal action under the UCMJ.

By the way, sir, we brief your staff on that periodically also.

Chairman WARNER. That is correct.

General Schoomaker, we have heard the Inspector General discuss what he observed and his recommendations for what he needs to be fixed. Please summarize for the committee what the Army has already done to better prepare the units, especially tactical units, for the environment they will face in Iraq and Afghanistan and the detention operations and tactical human intelligence they will have to conduct to be successful?

General SCHOOMAKER. Sir, we have a continual process of rolling the things that we are learning back into the training and mobilization process of our units. We have affected all the way from the point of how we are alerting units, how we are preparing them for deployment, what their post-mobilization training is, the reinforcement of the individual annual recurring training on the Geneva Conventions and the law of land warfare, reinforcing with the leadership the challenges that they will face in this highly violent environment that requires a great deal of adaptation and judgment.

We have rolled it into our combat training center so that we offer specific replication of actual incidents that have been experienced in theater. We have brought soldiers from theater or that have recently served in theater into these training centers to address their specific experiences and setting the specific scenarios that we train on.

Of course, we are doing a comprehensive review of our doctrine, and as we speak there is a detailed action plan that the Department of the Army has put together. Many of these actions are already being implemented. But we have a matrixed action plan that we will follow up through and do a very comprehensive—it is going to take us months to do.

Having said all of that, as we get ourselves set we are going to continue to roll lessons learned in, to monitor the adaptations and the nuances of the environments that we find ourselves in, and this is going to be a continuing, evolving process.

But again, I would like to reemphasize: the principles, the values, the standards do not change. Having an Army of character, with soldiers of character that understand the values of the American people, that understand the values of our government, that understand the values of our institutions, are fundamental. Those do not change. We have to continue to reinforce them. We have to continue to reinforce the leadership aspects of what we have.

So this is something that as we go into the 21st century is going to continue to be a challenge for us to deal with.

I would just wrap up one thing. As you heard, the majority of the incidents of abuse occurred at the point of capture. You have to remember that at the point of capture you are transitioning from a very high level of violence, where the very same people you have captured have been trying to kill you just seconds before, where it is in the middle of a rumble that this is occurring. It is understandable that there can be misjudgments, and that is why we have to train our leadership and remind our leadership that it is at this point that they have to be very well-prepared to control the aggression and the instincts of people that are in this situation.

You can remember having your adrenalin up before and how sometimes what you think might be a minor shove turns out to be something else.

Chairman WARNER. I am glad you brought that point up, because you can speak, as can Secretary Brownlee and indeed General Mikolashek, from personal experience under those circumstances in your earlier years of military service.

Mr. BROWNLEE. I might say, sir, that not only might these people have been the ones who were trying to kill you, but they may also have just killed some of your squad members.

Chairman WARNER. That is a very important point.

My last part of that question, I want to go back to it, and that is as a consequence of all of this recognition now that we have a problem, whether it is at the point of initial contact of the detainee following a firefight or other combat activities all the way through the prison system, I hope the pendulum has not swung so far that we are not fully exercising our obligation to those combat forces to, within the framework of the several treaties, Geneva treaties, and Army doctrine, to continue to get the intelligence that is essential for that battlefield soldier.

If you could just touch on that and then perhaps amplify it for the record, I would be appreciative.

General MIKOLASHEK. I can promise you that is of the highest concern to me. We must be very careful that we must not mistake the fact that this is a very dangerous environment and one which is going to continue our leadership and our soldiers, and one in which we must be very careful that we do not overreact and fail to or put in place such things that they make fatal mistakes, fatal hesitation, or we fail to do what we are allowed to do and what is proper to do and what we must do to ensure the safety and the success of our operation.

[The information referred to follows:]

The Commander of U.S. Central Command can provide the most authoritative assessment as to the effects of the investigations, inspections, and assessments of Abu Ghraib, as well as detention and interrogation operations, on intelligence production.

Chairman WARNER. Secretary Brownlee, do you have anything to add to that?

Mr. BROWNLEE. Sir, I share the concern. We all worry about it. I have talked in some detail with our G-2, General Alexander, that you know well. We have all discussed that some of these abuses that occurred, many of them, most of those that occurred at Abu

Ghraib, did not occur with detainees who were even being interrogated, were not even the subjects of interrogation. But unfortunately, some of the measures that may have been effective are no longer used.

But sir, we would never want our soldiers to engage in anything that was inhumane anyway. The intelligence experts that I have talked to tell me that these abusive methods are usually not very effective anyway.

Chairman WARNER. I have to move along. If you wish to amplify that for the record—

Mr. BROWNLEE. Yes, sir. We trust that our people are going to find ways to be effective within the right constraints.

Chairman WARNER. I say to colleagues, we went out of order of our regular order to accommodate Senator Levin. So I will go back. Senator Sessions, and then we will come to this side.

Senator Sessions.

Senator SESSIONS. Thank you, Mr. Chairman. I want to express, Secretary Brownlee, my appreciation for the effective way the military has dealt with this issue from day one. I remember distinctly that when the first report of these abuses in Abu Ghraib were made, investigation was commenced the next day. Within just a few days, people were suspended from their positions. People are being charged criminally who have been abusing privileges.

Mr. Chairman, it is good for America, the military, the people of Iraq, and the world to know that we will not tolerate the kind of abuses that we saw there.

It is a very dangerous and stressful area of the world. It is hostile. Our enemy, which we do not spend enough time talking about, decapitate their prisoners. They have no mercy for their prisoners. They for the most part overwhelmingly do not qualify for treatment under the Geneva Conventions. That is a fact. We have had that hearing in the Judiciary Committee a number of times, and we have discussed it here. They are not lawful combatants; they are unlawful terrorist combatants. But we give them the protections anyway because we have high standards of character and discipline and decency, and I appreciate that.

General Schoomaker, it is absolutely correct that we should not overreact. We want our soldiers right up to the limit of what they legally can do to obtain good intelligence, to help save our lives, to help save the lives of President Karzai or Prime Minister Allawi or our soldiers that we sent there, our sons and daughters who are there. Intelligence saves lives.

I have to tell you, I came back from Iraq the week of July 4 with Senator Lieberman and Senator Nickles. Several others were not able to make it at the last minute. We had a nice group that went there. I heard on two different occasions that our soldiers are worried. They are tentative in interrogations. They feel that if they violate some rule, they are not real sure what that rule is, they might get prosecuted, be held up before some Senate committee, be second-guessed by people who are not in combat, not at risk, and that the intelligence, the level of intelligence has dropped off noticeably.

General Schoomaker, can you share any thoughts on that?

General SCHOOMAKER. Sir, I share your feelings. I have no evidence that intelligence has dropped off as a result of anything that

has happened over there. But I do not have daily insights into that anyway, so your observations may be much more accurate than mine.

Senator SESSIONS. I will just say this. I heard it from two different sources from people absolutely in a position to know. In both cases it was raised early in the conversations to me spontaneously. So I hope that when we come up with the regulations, Mr. Secretary, that we do not overreact and deny our people legitimate techniques, just like sophisticated detectives use in America and other things. You do not have to give people steak three times a day. There are things you can do to create a situation that would enhance the possibilities of obtaining information that do not violate standards of decency.

General SCHOOMAKER. Sir, if I could just add. Those of us in this room and the American people ought to understand how dangerous this enemy is and how dangerous a situation we are in. Folks that are underestimating the challenge that we face in this century and today are making a serious mistake.

That does not excuse unlawful conduct, unethical conduct, and the rest of it on our part. But I absolutely subscribe to what you just said. We have to be darn sure that we are not overreacting in a way that is removing lawful tools or setting conditions that will cause people to be hesitant, to second-guess, and to think that we would not stand behind them if they are acting in good faith to do what is proper in the situation.

If you have never been in one of these places, been in proximity to these prisoners, and seen what kind of people they are, what goes on, and the kind of pressure that these soldiers are under day in and day out, having to live and deal with these people, and the things that they do and the things that they want to do, you cannot comprehend the pressure psychologically, physically, emotionally, and all the rest of it, that these soldiers are under.

That is one of our most important responsibilities, the Secretary and myself, to ensure we prepare these soldiers for that environment and that we do everything that we can to stand behind those that are attempting to serve honorably and do what is right for this Nation.

Senator SESSIONS. You said something else, General Schoomaker, that is correct. I was a Federal prosecutor and most of the abuse situations do occur at the conclusion of the hostile act. The police officers I have had to investigate and prosecute, are pumped up at that moment. They have been afraid. Their life has been at risk. This is a life and death struggle, and it is hard to just stop that and be perfectly nice. Sometimes they cannot control themselves or do not control themselves. They should. So that is difficult.

With regard to the regulations, between the MP and the MI, that is a minor nothing. That is what General Abizaid was expressing frustration about, not that the doctrines had caused this abuse. He was frustrated about the doctrines that did not make sense, that an MP may have been a police sergeant back in the United States and could not in any way participate in assisting an interrogation. I hope that when you write the doctrine you break down that wall. It makes little sense to me.

Thank you, Mr. Chairman.

Chairman WARNER. Thank you very much, Senator.
Senator Kennedy.

Senator KENNEDY. Mr. Chairman, I would like to yield to Senator Reed for this round and reclaim my right after that.

Chairman WARNER. Senator Reed.

Senator REED. Thank you, Mr. Chairman.

General Mikolashek, Secretary Rumsfeld has acknowledged that he ordered an individual in Iraq, a detainee, to be hidden. General Taguba in his report indicated that he observed on several occasions individuals who were being hidden from the International Committee of the Red Cross. This seems to be a pattern. Did you examine this issue?

General MIKOLASHEK. Sir, we looked at detainee accountability. We asked those questions about the so-called "ghost detainees." During the conduct of our inspection we found no evidence of the so-called ghost detainees that were in existence. However, we did find that our processes for accounting for detainees based on the volume and the number of them, the automated processes we have, the administration of those, are overwhelmed. The systems are complicated. They do not interact.

So it is certainly—

Senator REED. Let me understand your response, General. Today there are no ghost detainees that you found?

General MIKOLASHEK. That we have found during our inspection, no, sir.

Senator REED. Are you disputing General Taguba and the Secretary of Defense?

General MIKOLASHEK. No, sir, I am not.

Senator REED. But you chose not to look into how that happened?

General MIKOLASHEK. We did not go back and do a postmortem on that particular issue.

Senator REED. So how can you conclude today that there has been no systemic problems with respect to the treatment of detainees in Iraq?

General MIKOLASHEK. Again, we looked at during our inspection whether those people existed, and we could find no evidence at the time.

Senator REED. There is evidence that they did exist. There is evidence that that is contradictory to our obligations under the Geneva Conventions. There is certainly a suggestion that an order was given by the Secretary of Defense that had to be transmitted through the chain of command, which would include higher ranking officers. You looked at none of that?

General MIKOLASHEK. No, sir, we did not look at that detail into that specific line on that particular issue. We looked at how we accounted for and took care of the detainees.

Senator REED. General, the premise of your report, that there has been no systematic problems, is undercut by the fact that you didn't look at some systematic problems. That was one.

General MIKOLASHEK. We viewed the system as accountability of detainees, sir, and that was our approach.

Senator REED. Let me go back to another situation and that is the command climate that existed, not just as you inspected but

prior to the inspection. Did you indicate or did you ask people about what policies, either verbal or whatever, were in effect? Was there any condoning of this or any encouragement?

General MIKOLASHEK. Sir, again, as we looked at all the abuse cases, and we did—I think your question gets right at the Abu Ghraib case in particular, and that was just one of many—we did talk to the soldiers who were not necessarily involved in the criminal side of that investigation. In terms of leadership and command climate, it did present some problems. In terms of an environment that would condone this kind of behavior in an overt way, we did not see that, but probably in an ommissive sense.

Senator REED. How far did you go up the chain of command in your climate survey?

General MIKOLASHEK. Sir, our climate survey, we really focused on the soldier level.

Senator REED. So you cannot offer a conclusion with respect to anything above the battalion or brigade headquarters? You did not look at that, is that correct?

General MIKOLASHEK. No, sir, in terms of command climate—I am not sure—the soldiers participate in the survey and they gave us a lot of feedback on the command climate across the board, because these surveys went throughout the population and not, again, focused on an individual unit. But in our look at that one particular case, interviews with soldiers who had redeployed, it was a less than ideal command climate.

Chairman WARNER. Excuse me, Senator.

I understood you to say in your opening comment that your inspection went up to the major general level.

General MIKOLASHEK. We did; we interviewed. We interviewed, but they did not necessarily participate in the command climate type survey.

Senator REED. Did you follow up the results of the survey, which suggested a very poor climate, however you define it, with higher ranking officers at the major general level and above?

General MIKOLASHEK. I am not sure I understand your question, sir.

Senator REED. The finding is that there is a poor command; there is a poor climate, presumptively in the situation where orders about treatment, recordkeeping, all of this. Soldiers are telling you, “we just did not get the direction, no one cared about it,” which would suggest I think to you as a professional officer there is a real problem here. Did you pursue that problem?

General MIKOLASHEK. How far up did that go is your question. Yes, sir, that probably extended up to the brigade level.

Senator REED. Did you go beyond the brigade level?

General MIKOLASHEK. No, sir, because we think it ended there. That is where the problem was and the solution was.

Senator REED. You are defining the investigation to limit the investigation. I find that to be unsatisfactory.

One other systemic issue is the responsiveness of the chain of command at the highest levels to reports of abuse. I think you would agree that is a systematic issue. Last fall, in October, the ICRC gave a report to General Sanchez’s headquarters, which suggested in very detailed terms that there were abuses, blatant

abuses: naked prisoners, prisoners being abused, prisoners' physical marks, not—well, I do not have to go any further.

Did you look into whether that complaint was responded to effectively by General Sanchez and his chain of command?

General MIKOLASHEK. No, sir, we did not follow that thread from the ICRC reports. We did know that the command was concerned about the treatment of the detainees and hence the Miller and Ryder reports that investigate, or inspection visits were called for. But again, when those ICRC reports were made available we did not go back and do the postmortem as part of this inspection. But I know that there are others that are looking at that.

Chairman WARNER. I would put a word of caution in. The committee is guarding meticulously the material of the ICRC. It is classified. It has been made available by the Department of Defense. So in your colloquy, continue your questions, Senator.

Senator REED. Mr. Chairman, I have a public report from the ICRC which was placed on the web by somebody, which we have had access to for years. So any questions about the report, I can refer it back to that report.

Just a final comment. It seems to me, General, that it is very difficult to reach the conclusion that there was no systematic problems in the treatment of detainees. You have not looked seriously at the ghost detainees situation. You have not looked at the responses of the chain of command to evident explicit reports of abuse. This is just again reinforcing the conclusion that there were five or six aberrant soldiers, and I do not think you have done the job that you have to do. Maybe you were told not to do it, but I do not think you have done the job.

General MIKOLASHEK. No, sir, we were clearly not told not to do it, sir.

Mr. BROWNLEE. May I respond, sir? May I respond?

Chairman WARNER. I think it is an important question. Take such time as you need yourself, Mr. Secretary and the General, because he is raising an issue that is of concern to a number of Senators, and that is the level of accountability, whether or not it is confined to the soldier level or it goes on up.

It is clear in your opening statement that you interrogated general officers at the rank of two stars. Am I not correct in that?

General MIKOLASHEK. Sir, I would say we interviewed rather than interrogated.

Chairman WARNER. Let us check the dictionary, but anyway.

Secretary Brownlee.

Mr. BROWNLEE. Let me just re-emphasize, sir, that this was a theater-wide investigation of detention operations or inspection of detention operations to determine if there were problems elsewhere. Now, when General Mikolashek went and did his inspection he found no indication of detainees. When it was later revealed there was one, it did not indicate to anybody that was a systemic problem across the operation.

Second, what General Mikolashek said when he was talking about command climate, when he found something less than satisfactory, it was primarily in the soldiers that were in the units at Abu Ghraib.

General MIKOLASHEK. A few others across the theater, mostly having to do with quality of life and austere living conditions and so forth, sir.

Mr. BROWNLEE. Which we had determined, and those are still under investigation and some of the cases are now within the purview of the UCMJ.

Chairman WARNER. We have made a determination that this hearing will continue after the votes, so we will have an opportunity for a second round. But I want to make sure that the Inspector General had adequate opportunity to explain exactly what questions he did pose to general officers and did it relate to the culture issue, which was one brought up by Senator Reed.

General MIKOLASHEK. Sir, when we talked to the senior leadership we were trying to find out what their expectations were, the difficulties they were having in managing these operations. So we looked at it from a perspective of what kind of problems are you having.

We also asked some specific questions about how the decisions to make the organization of some of those interrogation facilities were—we talked to General Taguba about his findings. So it was more on the line of the details of the inspection and a look at how those operations were conducted, rather than on their perspective of the command climate.

Chairman WARNER. We will have to return to this issue.

Senator REED. Mr. Chairman, if I may.

Chairman WARNER. Yes, I will give you adequate opportunity before this hearing is concluded.

Senator REED. Thank you, Mr. Chairman.

Chairman WARNER. Senator Talent.

Senator TALENT. Thank you, Mr. Chairman.

I do not resist the conclusions that you have reached. This Senator never doubted for a minute, and said so repeatedly at home and here, that no senior leader in the United States Army or in the Government in any administration would tolerate inhumanity or cruelty to prisoners. I never doubted it for a minute, and I am not surprised that that is what you concluded.

Nor did I ever doubt for a minute, given my experience with the men and women in America's military, your conclusion that the overwhelming majority of our leaders and soldiers understood the need for humanity and fulfilled their duty and their obligations. That would be their instinct as well. We are talking about American soldiers, by training, by instinct, not just within the Army but within our culture as a whole. I should hope that they are not people who would abuse prisoners. I just never doubted for a minute, and I am not surprised that that was your conclusion.

I saw those pictures. It looked to me like what it is. It was a sicko scrapbook that a few bored people who were inadequately supervised—and I think we need to find that out—decided to compile about their experiences in Iraq.

The question that I have always raised, and I am confident that these court-martial proceedings will clear this up, is where was the immediate chain of command in that prison. People need to be held responsible for what happened.

The other concern that I have, and I will reflect what Senator Sessions said, is that we do not in our scrupulousness about this, which is very appropriate, and in these oversight hearings, which are very appropriate because they are leading to a conclusion that is vindicating our leaders and our soldiers and it ultimately will benefit the effort, that we do not create an overincentive not to do what they need to do to collect intelligence.

It is going to take a lot of courage on your part, but I hope that you and the senior officers will make clear to our people we have to get this intelligence. Ultimately this is about winning this war, and we need intelligence to win this war.

I appreciate you all being here. I would encourage members to ask questions about the process by which this report reached its conclusions. But as I said, I am not at all surprised. I would have been very surprised if any other conclusion had been reached, knowing what I know about the United States Army. You can comment on that if you want. That is really my only statement, Mr. Chairman.

Mr. BROWNLEE. Sir, first of all, we appreciate your comments. Just to reiterate, one of our great concerns remains that we continue to get intelligence, useful intelligence, that is useful at the tactical level, which is where we really need it in this urban insurgency in which we now find ourselves.

These kinds of changes in environment have changed our requirements somewhat. One of the things we found with the urban insurgency as compared to a large linear battlefield with large armies arrayed is that the demand for human intelligence increased our requirement for interrogators and interpreters. It also caused us to relook how we were training our intelligence officers and, rather than training them spending most of their training time on how to use technical overhead means, to use human intelligence.

So we are adjusting to this and our soldiers in the field are adjusting.

Senator TALENT. Mr. Secretary, I would not want my comments to be interpreted as meaning that I do not think there is more we could do to get intelligence or that I am shocked by isolated type instances or would be shocked by more isolated instances. It happens. War is very messy.

But anything that I have seen about this in the classified documents and in the open hearings supports your conclusion. As soon as this happened in a prison and as soon as senior officers—first of all, a soldier came forward—

Mr. BROWNLEE. Yes, sir.

Senator TALENT. —at considerable risk. As soon as senior officers outside that brigade found out about it, it stopped. In fact, it stopped before that. But I remember, and I was very proud of that fact, General Taguba went in there and within like 48 hours it stopped, and it stopped before. Senator Sessions and I were talking about that. But that put a stop to it.

So I am not at all surprised by the conclusions.

Yes, General?

General SCHOOMAKER. Senator Talent, if I could, I would just like to reinforce something here. First of all, I feel very strongly that those people that broke the law or knowingly violated regula-

tions should be held accountable for that, regardless of where they are, whether they are soldiers, noncommissioned officers, or commanders that were involved here.

But going back to the line that you had and what Senator Sessions had, we all are going to have to be very careful here, and especially members on this committee, those on the Hill, and those in the Department, that we do not take a great big broad brush and paint everybody that was anywhere near this business and taint them. If we send that message to our leadership, to our noncommissioned officers, and to our soldiers that that is what this is about, we will have exactly what you do not want, and that is overcaution. We will have people that do not believe that we stand up behind them when they were in positions under great pressure making decisions. We are going to have to be very careful that we pay attention to this in a way that this does not become something I do not think anybody in here wants it to be.

I do not mean to editorialize, but I am concerned as a professional officer because I have seen this occur in the past. When you start putting that kind of pressure down on people and they become overcautious—this business about zero defects. If you have not been under these conditions that these soldiers are operating in before, and nobody has ever tried to kill you and you do not understand what this is about, you cannot appreciate it.

We have to think about it. We have to stand up behind people that are trying to do right, underwrite some things that need to be underwritten, and hold those accountable who failed in their responsibilities or who knowingly violated our standards, our values, our laws, our regulations. They should be held accountable.

Senator TALENT. I am done, Mr. Chairman. I will just say, one of my staff people who is a former Army officer, as soon as this thing broke he sent me an e-mail, just incensed. He said that these knuckleheads would have imperiled what 900 of their comrades have died to achieve. That e-mail was the spirit of the United States Army.

Thank you.

General SCHOOMAKER. Thank you, sir.

Chairman WARNER. Thank you very much, Senator.

I thank you, General, for your observation. I share that observation. To the extent I and other members of this committee have been able to address this issue, we have done it fairly and we have done it openly, so that the world can see that in the United States when there is a wrong we address it. We hear all parties, and that is precisely what we are doing.

General SCHOOMAKER. Yes, sir.

Chairman WARNER. No one is trying to push this under the rug. But at the same time, those that are accountable will be held accountable, and in no way should their actions taint the heroic service of the 99.9 percent, as I said in my opening statement.

General SCHOOMAKER. Sir, first of all, I appreciate that, and I know that is what you are doing. I am making a statement that was not an allegation that anything like that was occurring.

Chairman WARNER. This hearing gives you that opportunity to make that statement openly and to the Nation, as you are the

Chief of this Army. You proudly carry out your duties, and I thank you for it.

Senator Kennedy.

Senator KENNEDY. Thank you. Thank you very much.

All of us at the outset of these hearings are enormously impressed by the courage and the training that our personnel have received in a very general way and the extraordinary heroism in which they are performing their duties. As someone that was in the Army a number of years ago, the level of the training for infantry members is just absolutely extraordinary, and all of us are very much aware of it.

What we are talking about are some policy issues and also some actions. But before getting into that, and I know I have limited time, but first of all, Secretary Brownlee, I want to thank you for all your good work on the up-armorings of the high mobility multi-purpose wheeled vehicle as well as the arming of the military, the trucks and other activities. You have just been enormously responsive to these challenges and been very responsive to any of us who have been interested in trying to follow this. I am very grateful for all you have done. You have been very proactive, gone out and visited these plants and factories, taken a great interest in it, and we are very appreciative of your leadership.

I want to ask you, Mr. Secretary, just before getting into these other issues. On the front page of the New York Times today, it paints a rather frightening picture of the Army recruiting. I have limited time, and I want to get into the other, but "in my lifetime I have never seen the Army as strained as it is today . . ." and "you have already taken the drastic measures to ensure enough soldiers—the recruiting, the retention benefits, the stop-loss expansion, the extensive Reserve and National Guard call-ups."

Then we have the final part of the column: "By dipping into the personnel bank, some recruiters say the Army is eating their seed corn; they are stealing from its future to accomplish their current mission, said one Army recruiting officer, referring to the enlistment of recruits sent to basic training."

What will you do if you miss the recruiting goals this time? Just a quick response on this if you would, please.

Mr. BROWNLEE. Sir, I want to tell you that the Army takes that very seriously. One of our highest concerns is our levels of recruiting and retention. I have told the Army many months ago. They know that the Army is under stress. I have told them: You watch the dashboard and do not come in and tell the Chief and I when the light is red; you come in and tell us when one flickers amber.

We have meetings on that. We just had one this week. We are staying abreast of it. We will take such measures as necessary to continue to meet our goals. We are concerned as you are that this gets more challenging as we go.

But we have never fought a war like this with a volunteer force and it is a challenge. I can only say that every American can be proud of these wonderful young men and women who have volunteered to serve their country in uniform during time of war. That is both active and Reserve components.

Senator KENNEDY. Thank you. We will have another chance to go through this.

General Mikolashek, part of the sense that you are probably feeling here is many of us have had the opportunity to go through these ICRC reports. We are also mindful that, even under the DOD detainee-related investigations, they are looking at currently, you are looking at 23 deaths—this has been announced by the Secretary—of individuals that died in detention, and 68 detainee abuses, now that they are getting into. The Secretary talked about it. There are a number of detainee deaths, some 30 cases, which have been closed, and a number of them are standing for court-martial.

I mean, so we have that kind of activity that the Secretary has commented on. We have, as has been mentioned, the public ICRC report that talks about beatings with hard objects, legs, lower back, groin, being stripped naked, solitary confinement, paraded naked, acts of humiliation.

Their conclusion: These methods of physical and psychological coercion were used by the military intelligence in a systematic way. The ICRC used the words “systematic way.” We are not just making this up. This is in this report.

The list of reports that go on have been well-documented, and this represents only a part of them. Some of them demonstrate the progress that has been made after these matters were brought to the attention.

So this is a very important measure, and it is something that some just say, “well, it is just an occasional, a few bad apples.” But if you take the numbers of different camps where these things were happening, the numbers of people that have been actually killed, even the court-martials, which are under now being considered because of abuses, they are not insignificant.

Now, in your report, in your summary, your report on page 3, you say: “Officially approved Combined Joint Task Force (CJTF)—that is Iraq—“and CJTF-180, Afghanistan, and early CJTF-180”—again, Afghanistan—“practices generally met legal obligations under U.S. law, treaty obligations and policy, if executed by trained soldiers under the full range of safeguards. The Department of the Army Inspector General (DAIG) team”—your team—“found that policies were not clear and contained ambiguities.”

This is your report. “The DAIG team found implementation, training and oversight of these policies was inconsistent.” This is your report. It is not ours. “The DAIG team found the policies were not clear and contained ambiguities. The DAIG team found implementation, training, and oversight was inconsistent. The team concluded, however, that, based on the review, that no confirmed incident of detainee abuse was caused by the approved policies.”

Well, this is what we are getting at. Is your report just about the approved policies or is it the total kind of picture, which includes the kinds of not clear, found that they were not clear and contained ambiguities? What was going on in those kinds with regard to detainees and training? Where you did not, the DAIG team found implementation of these policies was inconsistent; well, what happened when you had this inconsistent part?

I do not question or doubt that where everything was going well you are getting your results. What many of us are concerned about

is in your own report you say that was not always the way; it was not going on. But we evidently did not deal with that issue.

General MIKOLASHEK. Sir, our attempt to look at those policies that you described was twofold. One was to determine if they were within legal bounds; and the second was to determine if those that either applied within legal bounds or outside legal bounds did result in a case of abuse.

The report as written there talks about these are very high-risk measures that require an awful lot of oversight, supervision, and insurance. They were not always disseminated fairly, properly, and well-understood, nor were there all the safeguards in place or the risk mitigation efforts in place to ensure that those techniques were applied properly.

Then we looked at the abuse cases. We looked at the 94 that we had, went back and tried to find what caused those abuse cases. We could not find any direct link to one of those approach techniques that was used either properly that resulted in abuse or an approach technique that was used inappropriately as an intent.

But what we did find was that when people really stepped out of the bounds of those approach techniques or just the normal bounds of discipline and behavior, that is when abuse occurred. Or most of our cases, half of them, were the result of incidents right at the point of capture, so it did not involve interrogation. Actually, of the 94 there are somewhere around 8 or so that were involving interrogation processes themselves.

Chairman WARNER. Thank you, General.

Senator CLINTON, there are just a few minutes left on our vote. So you take such time as you need and I will see that that vote is held for you.

Senator CLINTON. Thank you so much, Mr. Chairman. I appreciate your courtesy as always.

Let me say at the outset that I agree with the report's conclusion that the vast majority of soldiers serving in our theaters of operation are serving with distinction. I also agree and endorse strongly General Schoomaker's passionate description of the dangers and threats that we face in this challenging environment. I say that because, at least speaking for myself, what I am attempting to understand and to point out are the ways in which our actions and the ways they are viewed around the world either assist or undermine our ultimate objective.

The 9/11 Commission is reporting today and in the executive summary among the recommendations which it makes is to prevent the continued growth of Islamist terrorism. Obviously that has to be one of our paramount goals.

In that, they make two points that I would just put into the record here: "Define the message and stand as an example of moral leadership in the world. To Muslim parents, terrorists like bin Laden have nothing to offer their children but visions of violence and death. America and its friends have the advantage. Our vision can offer a better future. Where Muslim governments, even those who are friends, do not offer opportunity, respect the rule of law, or tolerate differences, the United States needs to stand for a better future."

Then finally: "Develop a comprehensive coalition strategy against Islamist terrorism using a flexible contact group of leading coalition governments and fashioning a common coalition approach on issues like the treatment of captured terrorists."

So I wanted to put that into the broader context because, although I agree with the conclusion that the vast majority of our soldiers and other military personnel are serving with distinction, it is a mistake to refer to the Abu Ghraib Prison abuses merely as regrettable. That sends the wrong message.

I do not see the conflict between being as forceful in going up the chain of command, wherever that leads, in prosecuting those who have committed these abuses, and in recognizing we have to send a very clear message to all of those who are facing the daily dangers that General Schoomaker described so poignantly and effectively, that we do expect them to use their best judgment, their discretion; we know they are in a dangerous situation.

Several times the Secretary has made reference to the urban insurgency that we face, and we know that in an urban insurgency the track record is not good. You know what? When you look at urban insurgencies, governments and militaries like ours do not have a record of success. So we are starting to a great extent behind the eight-ball, and therefore we have to be smart about the strategies we employ. We also have to be smart about how we communicate what we do.

When someone like Senator Reed, with all of his experience and his deep love and devotion to our military and particularly to the Army, asks these questions, they are asked from a perspective of how are we going to win. Winning means we have to be smart about what we do, the example we set, the moral leadership we continue to hold in the world.

Now, there are many specific questions, but we have run out of time. I wanted to put that in context because I know that sometimes it seems a little bit as though there is total division even on our committee, which probably operates in a more bipartisan way than any committee in the Senate, thanks to our leader and our ranking member. Some people use their time very appropriately to defend and say very strong statements of support for the military. Others use their limited time to ask very hard questions. Both approaches are trying to get to the same point, but language matters. "Regrettable" is not strong enough, and failing to go up the chain of command is not smart.

So that is where many of us find ourselves, because we want to both recognize and support the dangers we face and, frankly, the uphill struggle we have against an urban insurgency that is populated by people who have no compunction about dying themselves. This is new for us, and we have to hold on to the moral leadership.

I would strongly recommend that perhaps a process could be started in line with this recommendation, one of the very excellent recommendations in the 9/11 Commission, that we would look at a new way to deal with this whole issue of interrogation and detention. There is a different imperative when you capture someone on a battlefield. But when they are inside a prison, that is a different environment as well. We have to begin to make better distinctions and communicate those.

I thank you for your work. But I would hope, General Mikolashek, that we could perhaps take another look at some of the ways what you have found were described. In the other reports that are being done, I hope we do go into the climate and up the chain, into the Secretary of Defense's office, not just because there are those of us who would like answers, but because we need to send that message.

Thank you, Mr. Chairman.

Chairman WARNER. Thank you very much, Senator.

We will resume the hearing. I intend to initiate it as the third vote is taking place, for all members. Then we will wait to see if any further come. Thank you very much.

[Recess from 11:24 a.m. to 12:13 p.m.]

Chairman WARNER. The hearing will resume.

Before turning to Senator Nelson, I would like to first put into the record regarding Senator Levin's opening questioning and the reply by General Mikolashek, the entire set of comments made by General Abizaid, and then invite our witnesses to make any further comments with respect to Senator Levin's question in the context of the entire statement by General Abizaid.

[The information referred to follows:]

SENATE ARMED SERVICES COMMITTEE HEARING TO CONTINUE TO RECEIVE TESTIMONY ON ALLEGATIONS OF MISTREATMENT OF IRAQI PRISONERS, WEDNESDAY, MAY 19, 2004, 8:30 A.M.

Senator COLLINS. General Sanchez, I also want to follow up on your November order putting MI in charge of some aspects of the prison. I also want to explore with you the role of MI, in general.

In the Taguba Report, the General says that the recommendation of General Miller's team that the guard force be actively engaged in setting the conditions for the successful exploitation of the detainees would appear to be in conflict with the recommendations of General Ryder's team and AR 190-8, that MPs do not participate in MI-supervised interrogation sessions. He also says that having MPs actively set the favorable conditions for interviews runs counter to the smooth operation of a detention facility. Didn't your order, where you involved the MPs in some aspects of the supervision of the prison, run counter to the regulation cited by General Taguba?

General ABIZAID. Senator Collins, may I address this?

Senator COLLINS. Yes, General.

General ABIZAID. First of all, we do not have all the facts. I think it is important for the committee to understand that. We need to see what we are going to hear from the 205th MI Brigade. What was in the mind of that commander? What did he think?

So if we can set that aside, let me share with you one of the findings that came out of the Department of the Army IG investigations but are preliminary. They are not approved. I am sure they will be shared with this committee. Our doctrine is not right. It is just not right. There are so many things that are out there that are not right in the way that we operate for this war. This is a doctrinal problem of understanding where you bring—what do the MPs do? What do the MI guys do? How do they come together in the right way? This doctrinal issue has to be fixed if we are ever going to get our intelligence right to fight this war and beat this enemy. So we have problems that have to be looked at from top to bottom in order to ensure that there is no confusion. Because, you see, the Ryder Report says one thing, the Taguba Report will say one thing.

Senator COLLINS. Exactly my point.

General ABIZAID. You are going to see that the Fay Report says something else. It is not because anybody is lying to anybody; it is because the system is not right. There are a lot of systems that are wrong out there that we had better fix if we are going to beat this enemy.

Senator COLLINS. But, General, I guess what concerns me is, when you have all these contradictory doctrines or all these contradictory findings, it suggests to me

that there was great confusion at the prison, and that confusion can set the stage for the kinds of unacceptable abuses that occurred. That is my concern.

General ABIZAD. It is a concern that I share, Senator, and we will find out the facts. But I would like to ensure that you understand that there is great confusion in a combat zone all the time—almost as much as there is here in Washington, but not quite.

Senator COLLINS. Thank you, General.

Chairman WARNER. Second, I want to give the witnesses an opportunity—I will let you lead off, Mr. Secretary—with regard to questions proposed by Senator Reed. Then I did a series of follow-up questions about, first, any restrictions on the Inspector General whatsoever to go up the ladder and talk to senior officers. He indicated in his opening statement he went to the two-star level, and was there some reason he did not go to the three, if necessary to the four. There is some need to have that part of the record clarified.

So if you would like to address that now, we would be pleased to receive your clarification, and then such additions as you desire to make to the record.

General MIKOLASHEK. Thanks, Mr. Chairman. I appreciate the opportunity to respond to Senator Reed's and your comments as well regarding those important issues.

Chairman WARNER. Senator Reed, and to the extent I joined in, raised a question which is very much on the mind of many Senators. The question is well put, and we want to make certain that you had full opportunity to respond to it.

General MIKOLASHEK. Sir, we had no restrictions placed on us other than the guidance that was issued to conduct this inspection to assess the whole system as was described.

Chairman WARNER. But that guidance in no way limited your ability to go all the way up?

General MIKOLASHEK. It did not if we would have seen it necessary, and our estimate was that our inspection concept and plan did not necessarily require that, although I think in retrospect had we found some need to go up we certainly could have and would have. But based upon where we were going and what we had found, we found that unnecessary.

We are also not bounded by the fact that if we found a crime that took place or another matter of concern or any other adverse action, we had the authority certainly to report that to the proper investigatory channels. We would not have pursued that as an investigation since that was not our intent, to investigate specific incidents that may have cropped up.

I mentioned the five cases that soldiers came to us and referred to as matters of abuse. We took those and reported them to the CID for their investigation. So when those things happened, we certainly referred them to the right channel.

To get at Senator Reed's question—and we may have been talking by one another as he was asking questions about command climate. I believe what he was asking—and I am going to put words in his mouth, but I think his question—

Chairman WARNER. You will have the opportunity to examine the record. Say what you can now and then examine the record and if necessary have a chat with him by phone.

General MIKOLASHEK. I will, yes, sir.

Chairman WARNER. I just spoke with him on the floor. He just was unable to get back over, but I want to make sure that that line of questions to my satisfaction is completed. We are concerned that so much emphasis—and the early facts clearly led to young and enlisted individuals, in most instances, obviously some officers in the intelligence chain of command. We want to clearly project, not only to the Army, to the DOD, to Congress, and to America, that we are looking at this thing top to bottom.

General MIKOLASHEK. Thoroughly and fully.

I think his question, if I could restate it, had to do with not so much the command climate as we described around the attitude of the soldiers—and I will talk about that in a minute—but I think his question was, did we find a command environment that existed anywhere that would have condoned, permitted, encouraged, or looked the other way when abusive situations took place or could have taken place.

We, our team, interviewed soldiers that were capturing people on the ground, that were detaining them at the forward collection points, up through all the internment and resettlement facilities. We talked to the commanders that were responsible for those facilities. I talked to the general officer level commanders at the division and task force level that had been involved in that.

I spoke with General Metz, who at the time of our visit was the commander of what is now the Multinational Corps in Iraq. I talked to him about our inspection and what we had seen, at least in the immediate aftermath of our visit. I spoke with Lieutenant General McKiernan, who is the land component commander in Kuwait who was overseeing the Taguba investigation at the time.

So we did speak with them and tried to get this assessment of that command environment, if that was his question. We found again, across all those commands and down to the tactical level commanders at almost any level, that they did understand their responsibility to treat these people humanely. It was very evident that it was a sincere, well understood, important requirement that they had to treat these people humanely.

So we found no evidence, again, in all those across the breadth of our inspection that there was that environment that permeated CJTF-7 or CJTF-180. We found very well-disciplined brigade, battalion commanders, and soldiers who understood that.

His second part of that I believe deals with the situation at Abu Ghraib.

Chairman WARNER. Take a moment to read your paper there.

General MIKOLASHEK. I did. Actually, it says "Tell him about Abu Ghraib." [Laughter.]

Chairman WARNER. Note where it came from. [Laughter.]

General MIKOLASHEK. So I think he was trying to hone in on the Abu Ghraib situation.

Chairman WARNER. And understandably.

General MIKOLASHEK. Exactly. It is certainly the most egregious, visible, and really horrible. It is off the scale.

So we did look at that and tried to determine, based on the information we had, without trying to contaminate or duplicate the criminal investigations that were ongoing or to confound the Fay investigation under Procedure 15 that is looking at the MI activi-

ties. So what was the command environment there? Was there this case of permission, encouragement, or just looking the other way?

We sought to determine that environment by talking to the soldiers who had redeployed, because they at the time of our inspection were in the demobilization process or had demobilized. So we looked at this through the eyes of the soldiers.

What we found, as I mentioned, was not a good picture. The soldiers told us that their living conditions were—and that is the case at Abu Ghraib—austere, the chain of command perhaps not as responsive to improving their living conditions; their security requirements there, that when mortar attacks started to occur or when the situation changed and became dangerous, the leadership failed to show up, was not present, beyond the people who were permanently stationed there; that visits were not—basically stopped from the chain of command.

Chairman WARNER. You mean the senior officers after a mortar attack on the prison compound just did not appear?

General MIKOLASHEK. This is the perspective of these soldiers who told us these things, and yes, sir, that is correct.

Chairman WARNER. Did you confirm the accuracy of those observations by the soldiers?

General MIKOLASHEK. Sir, if you review the Taguba report it generally agrees with what we found.

Chairman WARNER. That they found that to be correct?

General MIKOLASHEK. Sir, I think what we have to do is balance what these soldiers told us and what the Taguba report says, and they are generally in coincidence. So our assessment then again, based on the information that we had, is exactly that. Probably to go much further would now get into an investigation of that case and we did not want to cross that line.

Chairman WARNER. Did you have occasion to talk to Colonel Pappas or to General Karpinski?

General MIKOLASHEK. Sir, we talked to General Karpinski and Colonel Pappas about the guidance that they received and how they understood the orders that were communicated to them to conduct these kinds of operations.

Chairman WARNER. What about the environment or the culture, which is the subject of the—

General MIKOLASHEK. We did not ask that question specifically, but you can deduce from their statements and their responses that they were concerned mostly about the how-to piece. At least certainly Colonel Pappas was. But we did not find again across the breadth of our inspection that kind of environment.

Within Abu Ghraib it was a unique set of leadership circumstances that were unfortunate.

Chairman WARNER. You mean the improper leadership?

General MIKOLASHEK. Exactly, yes, sir, to go beyond that now gets into—

Chairman WARNER. Then you're into the investigation.

General MIKOLASHEK. Gets into the investigation which General Fay is doing and which the—

Chairman WARNER. Did you talk to General Fast?

General MIKOLASHEK. Yes, sir, we did, as part of our inspection, and again it was to achieve an understanding as to how the process

was set up, how the internment or the joint interrogation and debriefing center was established, the decisions that she made on how to establish it and who to put in command. That was to help us gain an understanding of how our doctrine did or did not support what she was trying to do and how our training and so on and so forth.

Chairman WARNER. What conclusions did you reach from what she advised you?

General MIKOLASHEK. Sir, not only just from what she advised but also from our own observations and interviews of the soldiers who were there, it is reflected in our conclusion about the need for more precise doctrinal specificity on how to organize these kinds of facilities, how to separate and more clearly define the independent and interdependent roles of the MPs and the MI; and then also to make sure that our training events replicate as close as possible those kinds of interactions that take place. All of those are confirmed in our report.

Chairman WARNER. General Fast had overall responsibility there, did she not? She is the two-star general who is the—

General MIKOLASHEK. She is the intelligence officer.

Chairman WARNER. —intelligence officer for General Abizaid; is that correct?

General MIKOLASHEK. For General Sanchez, now General Casey.

Chairman WARNER. General Casey.

General MIKOLASHEK. Sir, in terms of the interrogation process and the intel systems, she is as a staff officer responsible for that.

Now, since our inspection they have established a position of the deputy commanding general for detainee operations and in terms of the administration, in terms of the resettlement facilities, that has been transferred to him.

Chairman WARNER. Are General Fast's actions being further scrutinized in the several inquiries going on?

General MIKOLASHEK. Sir, I believe that—I am almost certain that under the Procedure 15, the General Fay report, that she is a witness.

General SCHOOMAKER. Sir, if I could, we need to clarify. General Fast is the—

Chairman WARNER. If I said "Fay," I meant "Fast."

General SCHOOMAKER. "Fast," yes. Major General Fast is the intelligence staff officer—

Chairman WARNER. That is correct.

General SCHOOMAKER. —for now General Casey, previously General Sanchez, not to be confused with being in the chain of command. However, General Mikolashek is correct. I believe her responsibilities and her interaction is being looked at under the Procedure 15, which is the intelligence investigation going on now.

Chairman WARNER. I just want to make sure that that is being examined.

General SCHOOMAKER. But the chain of command, again, ran through General Karpinski at Abu Ghraib, through the military chain of command.

Chairman WARNER. But this committee, you may recall, Mr. Secretary, was specifically asked to move her promotion expeditiously,

and we did that based on the recommendations from the Pentagon. I am just concerned about that situation.

Colleagues, thank you for indulging the chairman. I think Mr. Akaka is next.

Senator AKAKA. Thank you very much, Mr. Chairman. Thank you for being so patient.

I want to thank our witnesses also for being patient. General Mikolashek, I am interested in your finding 22 in your report, which refers to civilian contractors. Some quick questions here. Were all of the contractors U.S. citizens?

General MIKOLASHEK. Sir, let me—I believe so. Of the 31 interrogators, I believe so, if I could ask one of my officers. Yes, sir, they were. Those are all U.S. citizens, the interrogators.

Senator AKAKA. Who did the contractors report to in the military chain of command?

General MIKOLASHEK. There is a military intelligence supervisor or detachment commander that they reported to for their day-to-day work, as stated in the contract.

Senator AKAKA. Who in the military was responsible for overseeing or keeping track of the activities of the contractors?

General MIKOLASHEK. The immediate supervisor is responsible for how they perform their mission, their security, and what they did. Of course there is a contracting officer that then ensures that the contract was being followed. But in terms of what they did and how they performed, their oversight on a day-to-day basis was that military supervisor, that MI person in that organization to whom they reported.

Senator AKAKA. Since I read stories in the media and the mention of contractors I have been interested in knowing where they fit and who they were, and the reason for my questions.

This question is to the Secretary and to General Schoomaker as well as you, General Mikolashek. You have testified that contract interrogators and translators were of considerable value in Afghanistan and Iraq and state that in the future all such interrogators would receive formal military training in interrogation techniques. However, our laws provide that inherently governmental functions, including functions that call for the exercise of sovereign government authority and those that may significantly affect the life, liberty, or property of private persons—and this is what I want to underscore—must be performed by government employees.

An Army memorandum dated December 26, 2000, and still in effect today made the express determination that gathering tactical intelligence is an inherently governmental function. The memorandum states that intelligence at the tactical level is integral to the application of combatant power by the sovereign authority. The memorandum concludes: “At the tactical level, the intelligence function under the operational control of the Army, performed by the military in the operating forces, is inherently a governmental function, barred from private sector performance.”

Now, my question to all of you: Are you aware of this Army memorandum? In view of the memorandum, what is the legal basis for the Army’s decision to contract out inherently government functions?

Mr. BROWNLEE. May I respond to that, sir?

Senator AKAKA. Mr. Secretary.

Mr. BROWNLEE. Yes, sir. Sir, we have reviewed that memorandum. There is another place in that memorandum where it says that if these—I do not recall the exact wording, but if these functions are performed by contract interrogators under an entity, which in this case was Central Command or CJTF-7 specifically, then they would not be considered inherently governmental.

Senator AKAKA. Thank you. That answers it.

To all of you: One of the concerns that has been raised about the use of contract employees as interrogators and translators is that they stand outside the chain of command. The Taguba report states:

“In general, U.S. civilian contract personnel do not appear to be properly supervised within the detention facility at Abu Ghraib. During our on-site inspection, they wandered about with too much unsupervised free access in the detainee area. Having civilians in various outfits in and about the detainee area causes confusion and may have contributed to the difficulties in the accountability process and with detecting escape.”

A draft DOD directive included in the Army’s September 2003 guidebook for contractors accompanying the force specifically notes that commanders lack the authority to directly discipline contractor personnel. The directive states: “Commanders have no penal authority to compel contractor personnel to perform their duties or to punish any acts of misconduct beyond the Military Extraterritorial Jurisdiction Act of 2000. Contractor employees are disciplined by their contracted business entity through the terms of the employee and employer relationship.”

Do you see any problem with accountability under a system which provides that, absent emergency circumstances, a contracting officer rather than a commander of a facility like a prison is responsible for providing direction to a contractor and the contractor’s employees? Mr. Secretary?

Mr. BROWNLEE. Sir, may I respond? Yes, sir. Sir, clearly any contract employee like that, especially a contract interrogator, is supposed to work under the direct supervision of an officer or non-commissioned officer who would be the supervisor of that person. So these procedures are in place and if they were not followed then somebody was not following the law, the procedures.

The contract person of course can be terminated in terms of the contract. They can be fired. If the commander or the supervisor is unhappy with their actions, they can request that that person be terminated. If it is a criminal act they are subject to U.S. law and can be prosecuted under U.S. law.

Senator AKAKA. Thank you very much, Mr. Secretary.

Thank you very much, Mr. Chairman. My times has expired.

Chairman WARNER. Thank you very much.

Senator Ben Nelson, you have been very patient.

Senator BEN NELSON. Thank you, Mr. Chairman.

Gentlemen, there have been so many reports and investigations that it is almost like a mosaic. Some of the pieces are in place, and many of the pieces are not in place. We are not always sure when they are all going to be in place or what will be the next piece put

in, which gives it an appearance that it is not all done, which is accurate.

The question I have is that at the end of the day, whenever that is, and all the investigations are in and all the reports are in, can you assure this committee and the American public that we will have not only gotten to the bottom of it, but have also gotten to the top of it, whether it goes to the highest uniformed officer or the highest civilian officer?

Mr. BROWNLEE. Sir, I can assure you that these matters are under investigation and that I trust our legal system and the UCMJ and the U.S. legal system.

Senator BEN NELSON. So that there will not be any question left about whether, well, that was not part of my investigation, but it was not part of any investigation? That is one of the things that my colleague from Rhode Island was trying to get to: at the end of the day do we have enough to know that every uniformed officer who might be involved has been interviewed, interrogated, or whatever is required, and that nobody will be left out of the process or out of the investigation process when it is all said and done?

Mr. BROWNLEE. Sir, our intention is certainly to investigate this to the absolute limit and, when appropriate, prosecute it under the UCMJ.

Senator BEN NELSON. By saying that I am not trying to prejudge complicity here. I just want to make sure that we do not find out that was not looked into or it did not go that high or this is in another investigation, so that we know when it is all said and done that everything has been done that needs to be done.

General SCHOOMAKER. Sir, if I could attempt to do this.

Senator BEN NELSON. Yes.

General SCHOOMAKER. This is less like a puzzle and more like an architecture here. It has probably not been well-explained over time, but if you take a look at the Taguba report, that was done under the provisions of the investigative authorities of AR 15-6, which is our normal way of investigating, called upon by the commander in theater that had the problem. So that was one of them.

Another one was the Ryder report, which you are familiar with. The third one was the—

General MIKOLASHEK. Miller.

General SCHOOMAKER. The Miller report. Those three were all initiated early on in the situation here and were foundational.

The Secretary then directed the Department of the Army Inspector General, General Mikolashek, conduct an inspection, a broad-based inspection across the system, to find out not just in theater but across the whole system, to look at everything within the purview of what his charter is that you have seen. That excluded the things that are being actually investigated under Procedure 15 and the intelligence business.

I would say that the Miller, the Taguba, and the Ryder reports are like the foundation, that one of the pillars of this building now is this DAIG report of inspection. Another one will be the Fay investigation under Procedure 15.

There is also a Church investigation going on, and there is a Schlesinger one. I would say that is more like the umbrella over these columns that are there.

In all of these, if there is criminal activity or suspected criminal activity or malfeasance, it is referred to the Criminal Investigation Division. It is then investigated as a criminal matter, regardless of what the source of the information was on it. That is where in my view I am very confident that all of these allegations, regardless of where they may appear, will be investigated for their criminal aspect of it.

Senator BEN NELSON. Is the ghost detainee issue under investigation? Because there is an authorization, is that currently being investigated?

General ALEXANDER. Yes, sir, in the Fay—

Chairman WARNER. If the gentleman will kindly stand and identify himself.

Mr. BROWNLEE. This is General Alexander, our G-2, sir.

General ALEXANDER. Sir, it is being looked at in two areas, by the Central Intelligence Agency, by their Inspector General; and it is also addressed in the Fay report as we understand it.

Senator BEN NELSON. So that at the end of the day if there is any kind of inappropriate activity or questionable activity or illegal activity associated with that under the Geneva Conventions or in violation of any internal rules, it will be fully investigated? Or is it possible that that is a waiver that might be issued that will not involve any violation of any rules, it may be a waiver of rules? Or do we know?

Mr. Secretary?

Mr. BROWNLEE. I do not know of any waiver, sir. What General Schoomaker said I would have said also, is that as these other investigations are ongoing and as they emerge and activity is identified that appears to be criminal, we will then have the Criminal Investigation Division of the Army investigate those events and incidents to determine criminal liability and if necessary prosecute them under the UCMJ.

Senator BEN NELSON. No matter whether it is above you or below you in terms of command or authority?

Mr. BROWNLEE. Above?

Senator BEN NELSON. Someone superior to your position within DOD as well as below you. I think that is what we are really trying to get to. It will not stop somewhere.

Mr. BROWNLEE. If it is criminal activity involving a person in the United States military and is investigated by the CID and determined that then it would be referred to the Uniform Code of Military Justice.

Senator BEN NELSON. What if it is civilian?

Mr. BROWNLEE. Civilians, sir, are subject to U.S. law.

Senator BEN NELSON. My point is that at the end of the day these investigations are not just related to military personnel, or are they related to military personnel? That is what I would like to get clear: all these investigations, the architecture that you are talking about, General. I am not trying to trap anybody here. I am just trying to understand where it ends. I think I know where it begins, but I do not know where it ends, and then what happens for investigation of civilian authority.

Mr. BROWNLEE. Sir, even the General Taguba report identified civilians and recommended appropriate action be taken.

Senator BEN NELSON. But nobody above General Taguba's rank. I am just trying to find out how you get investigations and reports above your rank.

General SCHOOMAKER. Maybe it should help, our authority, the Secretary of the Army's authority, extends to the Army. The criminal activity that is identified that resides within the Army, the Secretary of the Army has the authority. He has UCMJ authority; I do not. He is the ultimate authority in the Army under UCMJ.

If there is indication of criminal activity that extends beyond the boundaries of the Army, it is referred to the appropriate investigating agency to be criminally prosecuted, whether that be the Federal Bureau of Investigation (FBI) or something in the civilian sense or whether it might be—

Chairman WARNER. Excuse me a minute. Senator, I think what you are trying to ascertain is, will some group of individuals or body look at, frankly, the senior presidential appointees in the Department of Defense.

Senator BEN NELSON. Thank you, Mr. Chairman. That is exactly what I am trying to say, without saying it.

Chairman WARNER. May I point out the following.

Senator BEN NELSON. Yes.

Chairman WARNER. That is that our committee initiated its hearing with the Secretary of Defense. Secretary Cambone came before the committee. We may have others before this committee in due course.

Second, the Schlesinger panel really has no limits. They can examine whomever they wish. So in the course of these matters there will be a review of the actions and inactions of those in the chain of command as it relates to the civilian control of the Department of Defense.

Senator BEN NELSON. But that will be generally, if I might ask, Mr. Chairman, within the oversight of this committee rather than within the purview of the military investigations?

Chairman WARNER. The Senator is correct, together with the Schlesinger panel, the Schlesinger-Brown.

Senator BEN NELSON. I appreciate the clarification.

Chairman WARNER. I thank the Senator.

Senator BEN NELSON. Thank you.

Chairman WARNER. In order of rotation, Senator McCain would be next. Thank you very much.

Senator MCCAIN. Thank you, Mr. Chairman.

General, in your summary here it says: "We are unable to identify system failures that resulted in incidents of abuse." Then later on you say: "Officially approved CJTF/CJTF-180 policies and early CJTF-180 practices generally met legal obligations under U.S. law."

I am very troubled by the statement "generally." What does that mean? What was not if it was "generally"? It is either specifically they were complied with or they were not. Now, what does "generally" mean?

General MIKOLASHEK. Sir, this reflects back on one of Senator Sessions' earlier questions regarding ensuring that we had the ability to use the best approaches to gain information from these detainees. What we found as we looked through this process in terms

of the development of the command policies, the commanders struggled to identify what approach techniques they could use within the bounds of legal limits to get the most information from these detainees.

Senator MCCAIN. They were either legal or they were illegal. "Generally" does not satisfy me.

General MIKOLASHEK. What we attempted to do was determine if intrinsically in any one of those approaches did they violate the standards of U.S. law.

Senator MCCAIN. Were there violations?

General MIKOLASHEK. Sir, in terms of the individual approach technique, we looked at each one of those to determine if in and of itself, if applied properly, would be illegal, and with the appropriate safeguards and risk mitigation efforts. We found that if all those things were in place they would be within the bounds of U.S. law.

Senator MCCAIN. Were they or were they not, General?

General MIKOLASHEK. Sir, they were, as with all those qualifiers, within the bounds.

Senator MCCAIN. If the qualifiers need to be far more specific: Unmuzzled dogs, is that in keeping with those policies or in violation of those policies?

General MIKOLASHEK. Sir, unmuzzled dog to be used in interrogation is in violation.

Senator MCCAIN. Yet those were approved by General Sanchez.

General MIKOLASHEK. Sir, we found no evidence of an unmuzzled dog to be approved by General Sanchez, based on our look.

Senator MCCAIN. We did.

What about the ghost prisoners? Does it not require a degree of coordination to move prisoners around a prison in order to avoid the ICRC?

General MIKOLASHEK. Prisoner accountability. Yes, sir, it requires that—

Senator MCCAIN. Was that in keeping with the approved CJTF-7 and CJTF-180 policies?

General MIKOLASHEK. Sir, those policies that we talked about, they specifically address the approach, the interrogation techniques, is what we are talking about.

Senator MCCAIN. So you do not even look at whether prisoners were moved around a prison in order to avoid ICRC interviews?

General MIKOLASHEK. Sir, we looked at accountability measures and how those—

Senator MCCAIN. Did you or did you not look at the situation which has been well-documented, where prisoners were moved around a prison in order to avoid interviews with the ICRC?

General MIKOLASHEK. Sir, during our inspection, the time of our inspection, we did look to see if that was taking place. We could not find any evidence of a—

Senator MCCAIN. There has been testimony before this committee that it happened.

General MIKOLASHEK. I think prior to our inspection that had taken place and was documented elsewhere. But in terms of our—

Senator MCCAIN. So it did not come to your attention?

General MIKOLASHEK. During the time that we visited these sites and talked to the commanders, we did not see that was taking place, although they did have struggles with and difficulty with accounting for the detainees in terms of administration.

Senator MCCAIN. A well-documented case of moving prisoners around to avoid ICRC interviews, which is in clear violation of any rule of war and treatment of prisoners of war, you did not address that issue?

General MIKOLASHEK. Those were being investigated under other means and our inspection attempted to look at what were those safeguards that would have prevented that from happening in place. In other words, the accountability, the documentation, the transfer of detainees between other governmental agencies or within our system, were those in place.

We found that, while the procedures were established, in terms of execution, it was not up to task. There were a lot of difficulties in accountability, processing.

Senator MCCAIN. But General, you say “officially approved policies and the early CJTF practices generally met legal obligations under U.S. laws.” Is moving prisoners around to avoid the ICRC investigation in keeping with CJTF-7 and CJTF-180 policies and obligations under U.S. law?

General MIKOLASHEK. Sir, those policies that I refer to in that particular finding address only the interrogation techniques and not the accountability.

Senator MCCAIN. So you did not address the issue of prisoners being moved around?

General MIKOLASHEK. We did address the issue of accountability, but it is in another—

Senator MCCAIN. Was it in keeping with approved—this is getting a bit bizarre.

Mr. BROWNLEE. Senator, may I? I can help a little bit.

Chairman WARNER. Mr. Secretary.

General, these are important questions. Take such time as you need to respond now. The Senator has tried to clarify.

Senator MCCAIN. Go ahead, General. I apologize if I interrupted you.

General MIKOLASHEK. No, sir, I understand. We did look at accountability under a separate finding that we have in terms of how detainees are being accounted for and managed and transferred. The finding that you are referring to specifically addresses only the interrogation policies that were published.

Senator MCCAIN. It addresses the treatment of prisoners if you are moving them around in order to avoid an interview with the ICRC. Maybe we are quibbling over words here, but the average citizen would say is it or is it not a violation if you are carrying out such practices, which are clearly in violation of every Geneva Conventions, every rules for the treatment of prisoners of war that I know of.

General MIKOLASHEK. Yes, sir, and the command policies that we reviewed that we refer to in that quote that you gave speak only of interrogation approach techniques.

Senator MCCAIN. But you see, that is not what your statement says, though. What your statement says, “Officially approved

CJTF-7 and CJTF policies and early CJTF-180 practices.” It does not say “interrogation practices.”

General MIKOLASHEK. Yes, sir, and perhaps it should have. But that was the intent behind that finding, to focus on the interrogation practices. Elsewhere we address the accountability issue.

Senator MCCAIN. Did you want to say something, Mr. Secretary? I thought you had something to add.

Mr. BROWNLEE. I was just going to say that the movement of detainees around we did not find was an approved policy in CJTF-7.

Senator MCCAIN. I am sure that cutting off their heads was not an approved policy. To say that it was not an approved policy, so therefore it does not need to be investigated—

General MIKOLASHEK. Sir, there are established procedures on how to account for detainees in terms of the forms that are required when you transfer a detainee from the military. Even from an MP to an interrogator, if he is going to be moved outside of the MP’s facility, there are procedures that have to be done and forms to be filled out, and so on and so forth.

Senator MCCAIN. Were those procedures violated when they moved the prisoners around to avoid ICRC interviews?

General MIKOLASHEK. Sir, we in our inspection did not find that that particular thing was happening during the course of our visits on the ground over there. But we did find that accountability procedures overall in terms of in-processing the detainees—

Senator MCCAIN. Do you know now that that practice took place?

General MIKOLASHEK. Yes, sir, and we believe that that was or is being looked at or examined in one of these other investigations that are ongoing. Since we did not investigate those particular incidents—

Senator MCCAIN. Of course, then the question springs to mind, what else did you not investigate? If we did not investigate a gross and egregious violation such as that, I am curious what else you did not investigate.

General MIKOLASHEK. Sir, our effort was to assess how all these processes and systems are working across all those functions throughout the commands in Iraq and Afghanistan.

Senator MCCAIN. Did you interview General Karpinski?

General MIKOLASHEK. Yes, sir, we did.

Senator MCCAIN. She claims publicly that she was prohibited from visiting certain interrogation areas. Did you get into that?

General MIKOLASHEK. Sir, we looked at the orders that she was given and her understanding of them and our understanding of the orders that were issued would be contrary to that. Much of that is still under investigation; that is apart from our inspection.

Senator MCCAIN. I thank you, sir.

Chairman WARNER. We will return to your questions if you will allow—

Senator MCCAIN. My time has expired.

Chairman WARNER. All right, let us have Senator Nelson, and then we can have another round here.

Senator BILL NELSON. Mine will be very quick.

Mr. Secretary, earlier the testimony had suggested that a lot of the abuse had taken place at the point of capture.

Mr. BROWNLEE. Yes, sir.

Senator BILL NELSON. There was an incident in the late 1990s in Kosovo, an airborne battalion that you had familiarity with as a former member of the staff of this committee, where there was roughing up detainees. There was rape; there was murder. A lieutenant had held a pistol to the head of a detainee.

So my question is, what are the lessons learned? What did we do to try, as a result of that experience in Kosovo, to change the doctrine and the training?

Mr. BROWNLEE. Sir, again those actions you describe were certainly not a part of any doctrine or training that was a part of the Army. These were individuals operating outside of that. These were individual actions and the lack of proper supervision by leaders where in this case the officers and the noncommissioned officers failed and the soldiers failed as well.

Senator BILL NELSON. Certainly this is not a part of the doctrine. Did we hold people accountable?

Mr. BROWNLEE. Of course, sir.

Senator BILL NELSON. All right. Then, Mr. Chairman, I would like to submit several follow-up questions for the record—

Chairman WARNER. The record will remain open.

Senator BILL NELSON. —to find out how, if this battalion, if it was held accountable, how that did not infiltrate through the organization so that we would have been more sensitive to this at the point of capture than we were once we got into the different circumstances in Iraq instead of Kosovo.

Mr. BROWNLEE. Could I respond to that, Senator?

Senator BILL NELSON. Please.

Mr. BROWNLEE. I would like very much to.

Chairman WARNER. The record will remain open until close of business tomorrow for purposes of questions related to this.

Thank you, Senator.

Senator BILL NELSON. Mr. Secretary, I have to be on air in 3 minutes.

Mr. BROWNLEE. Twenty seconds, sir. If you look at the magnitude of what our soldiers are facing there, we have had in our custody over time over 50,000 detainees. We have had several hundred thousand U.S. soldiers pass through this area of operations. We have during this period of time that General Mikolashek looked at 94 cases of abuse. The perspective of that would indicate to you that the Army has paid attention.

The Army is not perfect. Mistakes were made. They are still being made. This is a very dangerous and difficult environment, where soldiers are under great stress and pressure. As General Schoomaker pointed out earlier, many times down at the point of capture a soldier who has just been in a firefight with some of these people captures them. They have been trying to kill him. They may have just killed some of his buddies, and now he has them in his custody.

The American people should be greatly proud of the manner in which our soldiers have conducted themselves in this kind of environment.

Senator BILL NELSON. I do not dispute that. That is not the point. The point is did we learn any lessons? The point is if we are

in a war in another 5 years will we have learned the lessons from what we are going through now, which maybe we should have learned from the experience in Kosovo 5 years ago.

Mr. BROWNLEE. But Senator, I would assert that you cannot take one incident that happened in one battalion and say the Army should have learned from that and no soldier will ever make another mistake.

Senator BILL NELSON. Was the commanding officer held accountable? Was he disciplined?

Mr. BROWNLEE. I would like to talk to you about that.

Chairman WARNER. The Chief of Staff is nodding his head. We cannot record that.

General SCHOOMAKER. The answer is yes, but it is inappropriate for us to discuss the specifics of that in this forum.

Chairman WARNER. We will take that for the record.

General SCHOOMAKER. He was held accountable.

Chairman WARNER. Now we have Senator Sessions, and then we will return to another round of questions here.

Senator SESSIONS. As a result of this, Secretary Brownlee, has there been any enhancement in training for active and Guard and Reserve who may find themselves handling prisoners? Has the Army, as Senator Nelson raised, taken some steps for even greater emphasis on how to treat prisoners?

Mr. BROWNLEE. Sir, I want to give the Chief of Staff of the Army full credit here because he has totally revamped our training programs to reflect as near as is humanly possible the situation that we find on the ground in Iraq and Afghanistan. We have villages in our national training centers and other training centers where soldiers are exposed to conditions that some describe as even more demanding, but with less death and injury, than they might find there, with more difficult situations, dealing with people representing Iraqis, some of them are Iraqis, and in situations that will demand the utmost of them under a lot of stress.

Yes, sir, we are doing the best we can to replicate that.

Senator SESSIONS. I understand that, and I am glad that you are doing that. I thank you.

I would just note, I remember even in the early 1980s or late 1970s when I was in the Army Reserve I used to have to train our soldiers on the Geneva Conventions and the rules of warfare. So it has been taught for every soldier that has ever come through. What you are talking about is you are going to enhance the emphasis on it, and I appreciate that.

With regard to the higher ups, I suggest if they are involved—if they are involved, and I doubt that they are—in these kind of activities, it will come out this way: When those soldiers get prosecuted, if somebody either by written order or verbal directive told them to do this, they are going to say who told them. They are going to defend themselves by blaming whoever gave them authority to do this.

In fact, the danger is some of them may blame higher ups just to cover themselves, which is my experience in criminal justice. You always have to wrestle with it.

The aggressive approach you are taking to prosecute the people first who you have evidence on will result in a lot of information coming out. Will it not, General Schoomaker?

General SCHOOMAKER. Could I respond just quickly?

Senator SESSIONS. Yes, sir.

General SCHOOMAKER. What General Mikolashek was tasked to do was to conduct a widespread inspection of the system during a period of time, during a snapshot, a window of 5 or 6 weeks, where the intent was to make sure we have the procedures in place and the people understand, we understand, our responsibilities for the future. Those points that came up during his inspection—not investigation, but inspection—that indicated that there might be some reason to pursue this in a criminal sense, it was referred. But that was not his task to do that, nor was it his task to recover ground that has already been covered or is being covered by investigations that are ongoing.

So what he is talking about here is, was he going and looking at whether or not we have in place the proper procedures, policies, and doctrine that, if followed, will have us be effective within the law and within the purpose of which we operate. That was his task, understanding, as I tried to describe in the architecture, that he was not doing what the Fay investigation is doing in the intelligence aspect of this. That is complementary to his efforts, and then it will be covered in more detail as the Church and the Schlesinger reports wrap it all together.

It is important. It is like an accident report. Almost every time in an accident report, whether it is an aircraft or an automobile accident or something, one of the first questions is were there procedures in place that, had they been followed, would have prevented this? The answer is generally yes. The next question is, were those procedures followed, and the answer is generally no when there has been an accident. That is really what this is about in this inspection.

Chairman WARNER. I just want to thank the General. I think that helped clarify precisely what this hearing—when we opened this hearing I went into that in my opening statement. But it needed to be repeated.

Thank you.

Senator SESSIONS. I agree that we do not have and should not have any policies that allow prisoners to be moved around, to be hidden from the Red Cross or any other group or that kind. But General Mikolashek, the accountability problems you are talking about, if the paperwork is done right and prisoners are properly accounted for it either makes it impossible to do that or it makes it easy to prosecute anybody who does that; is that correct?

General MIKOLASHEK. That is correct, sir.

Senator SESSIONS. That is what you have been focusing on, is tightening up those procedures?

General MIKOLASHEK. Yes, sir. The procedures are in place, and it is sound. Now, there are some ways that we could improve it, because it is fairly complex in many ways. It has created a backlog for processing the detainees. Those are the things that we need to fix. As I mentioned earlier, the commanders on the tactical level are holding people longer, so they too need to have those systems

in place to make sure they account for the detainees they do have in custody or in movement.

Senator SESSIONS. With regard to the civilians, somebody raised a question about their being able to be prosecuted. In 2000, I sponsored legislation that is the basis now of prosecuting civilians abroad who violate law. They cannot be prosecuted under the Uniform Code of Military Justice because they are not a soldier, but they can be prosecuted under this law by the Department of Justice.

We reviewed it again and, Mr. Chairman, as part of the defense authorization, bill language that will strengthen that a good bit. We are in a stronger position than perhaps we used to be in the ability to prosecute any contractor abroad who would violate the law.

We found, General Mikolashek, that you never found any order from any higher-up, either written or verbal, that would have authorized the kind of abuses we saw at Abu Ghraib. Have you?

General MIKOLASHEK. No, sir. No, sir.

Senator SESSIONS. Has any report to your knowledge found that?

General MIKOLASHEK. No, sir, we did not see any.

Senator SESSIONS. The order that General Karpinski referred to, I know General Taguba did not agree with her interpretation of that, and you also do not agree with that?

General MIKOLASHEK. That is a correct statement.

Senator SESSIONS. Thank you, Mr. Chairman.

Chairman WARNER. Thank you.

Senator McCain.

Senator MCCAIN. Thank you.

Let me just make one thing clear, General. One of the terrible things, many terrible things about war, and one of the terrible things throughout history is the brutality that is inflicted on the battlefield. I do not think anyone that understands war—and I think most Americans at least have some understanding—feels that this is anything other than a situation where sometimes these things happen. We try to prevent them. We try to train our military personnel not to commit abuses on the field of battle. But they happen.

What I am trying to get at here and what I hope that the focus of your investigation was whether there was a systemic problem, and that is what this is all about. I would appreciate very much in writing if you would tell me what practices “generally” means, in other words what exceptions were they and under what circumstances.

I am still troubled by this aspect of the ghost prisoners because it seems to me that that should have been a subject of your investigation. Any violation should have been. So I hope that you will take another look at that. Or maybe it is the subject of other investigations, but I do not see how you can judge the practices and keeping with approved policies if this kind of violation took place.

[The information referred to follows:]

During my testimony on 22 July, you asked me several questions regarding the policies in place regarding detainees. Specifically, you asked me to explain language from the following finding: “The DAIG Team found that officially approved CJTF-7 and CJTF-180 policies and the early CJTF-180 practices generally met legal obligations under U.S. law, treaty obligations and policy, if executed carefully, by

trained soldiers, under the full range of safeguards.” While this response is unclassified, the CJTF-7 and CJTF-180 policy documents that it refers to are classified. Therefore, a meeting in a closed session may be a useful forum to explain the meaning more completely.

The language in question is in Finding 8 of our report. The specific topic of that finding was the “interrogation approach technique” policies that were in place in CJTF-7 and CJTF-180. This finding had a singular focus—interrogation approach techniques. As such, that specific finding statement did not relate to other policies regarding administration and care of detainees. An “interrogation approach technique” is specifically defined in PM 34-52 as part of the interrogation process. It relates to the atmosphere with which the interrogator will question the detainee. As such it may relate to matters regarding security of the detainee.

We used the term “generally met” to indicate that the vast majority of the “approach techniques” were in compliance with legal obligations. A few of the techniques, however, give rise to legal and practical concerns, hence the use of “generally.” In the classified version of this report, we have included greater discussion of the specific techniques that gave rise to legal concerns. The major point that we intended to make in our report, however was that the instructions that were transmitted were fraught with legal peril, required an extraordinary degree of specialized training and careful legal interpretation and close supervision during use of those techniques. Legal obligations under treaties, U.S. law and policy established a minimum standard of behavior. The published policies took soldiers right to the limits of the law and, probably, required them to apply techniques that required great precision to avoid violating the law.

At the same time, I understand that the commanders and their legal advisors in theatre were operating under extreme pressures. In the hopes of saving U.S. and coalition lives, they created high-risk procedures. We could not say whether the publication of those procedures led directly to any case of detainee abuse. The policies may have established conditions for abuse, but our assessment did not reveal where this may have occurred. Other investigations, both administrative and criminal, examining specific incidents of abuse, have, and will be able to, shed additional light on this connection.

During the hearing, you asked me if the policy regarding so-called “ghost detainees” practice “generally met legal obligations under U.S. law, treaty obligations and policy.” As noted above, the finding that included the language cited did not deal with “ghost detainees.” We did make separate findings on prisoner accountability systems and procedures. We found that our regulations require all detainees to be accounted for properly. We found no direct evidence of the ghost detainees at the time we inspected. Accordingly, we determined the policy stated in the regulation to be proper. If “ghost detainees” were being held, that would appear to be a violation of that policy. Our Finding 8 noted above only applied to interrogation techniques policies and did not apply to any other policy regarding detainees. Therefore, your question regarding whether the “ghost detainee” practice “generally met” legal standards is inapposite as it crosses between two unrelated issues.

As stated in Finding 12, we did find that there was a failure of prisoner accountability across the theatre. My inspectors did inquire into the “ghost detainees” and found no hard evidence of them at the time of our inspection, only second-hand reports, including those of the ICRC. Therefore, we were unable to make concrete conclusions in our report. Furthermore, my mandate to inspect did not include access to programs being administered outside the Army, either by the Department of Defense or other agencies. We did find, as noted in Finding 12, a general failure to administer prisoner and detainee accountability in accordance with law and procedure. Other investigations have considered violations of the prisoner accountability policy, to include reports of instances of “ghost detainees.” As you are aware, the report by General Kern has made specific findings on this issue and recommended further investigation by other Departments.

Our report was an inspection, not an investigation. It examined systems across the Army. Where the systems failed, the inspectors attempted to make a determination of a root cause. Other reports—of investigations into specific acts of alleged misconduct—should shed additional light on the issues you have raised.

Senator MCCAIN. Secretary Brownlee, one of the worst things I have learned from Senator Warner is that occasionally we stray from the subject at hand, and I am straying now. The General Accounting Office (GAO) reports a \$12.3 billion shortfall between now and September. What can you tell us about that?

Mr. BROWNLEE. Sir, I read that article this morning in the paper, and I know that there is a shortfall.

Chairman WARNER. That was my first question to him this morning.

Senator McCAIN. I am sorry, I am sorry.

Chairman WARNER. I want him to repeat it for your benefit.

Senator McCAIN. I can read it.

Mr. BROWNLEE. I would be happy to address it, sir.

Chairman WARNER. Let us repeat it for your benefit.

Go ahead.

Mr. BROWNLEE. Sir, we of course have been having meetings in the Pentagon frequently about these same issues. We knew what the shortfall was. We addressed them. All the Services came forward and identified items that could be deferred and dollars that could be moved around, and the Army received an additional \$4 billion in that exercise to help the Army.

In addition, Congress is considering an appropriations bill now that includes a \$25 billion supplemental for 2005, but the Department would have access to those funds upon enactment. So that could be used also to bridge this gap.

I was not aware it was \$12.3 billion. I pretty much knew what the Army's shortfall was.

Senator McCAIN. Here is my point. I am sure that Senator Warner made the same point. We are robbing Peter to pay Paul if we are taking money out of the \$25 billion for 2005 in order to pay for 2004, because the 2005 \$25 billion was to take care of problems in 2005.

It would be very helpful to all of us if in September—and we are going to be in session for 4 weeks in September—that DOD—and the reason why I address you is the bulk of these expenses are Army-related since the bulk of the mission is being carried by the United States Army. I mean, certainly you could argue that, with all deference to the outstanding job that the other Services, particularly the Marine Corps, are doing.

If you would give us some estimate—there is no reluctance on the part of Congress that I have ever seen to providing the money that is necessary to get the job done in Iraq. So I would hope that you would carry the message back to Secretary Rumsfeld or whoever needs to “come and tell us what you need.” The worst thing: we really feel that it is not in keeping with our responsibilities if we have to read about a shortfall in the newspaper or get it from the General Accounting Office, which is a branch of Congress, not of the executive branch.

It would be helpful to us, because immediately people come to us: Well, what do you think about the shortfall? Well, I do not know anything about the shortfall because we have not been briefed on it.

Chairman WARNER. Your objection is well-taken, Senator, if I may say. Several colleagues have raised this today, and I intend to write a letter to the Secretary of Defense broadening your question to throughout the DOD structure, not just limited to the questions primarily we discussed on the Department of the Army this morning. I intend to see that all Members get the Secretary's response to this, even though the Senate will not be in session.

Senator SESSIONS. Mr. Chairman, could I clarify one last question I raised.

Chairman WARNER. Yes.

Senator MCCAIN. Could I ask? General Schoomaker wanted to—

General SCHOOMAKER. Sir, I just wanted to help clarify this a little bit, because we appreciate exactly what you said. More than 2 months ago, we addressed this kind of at the DOD corporate level. The figure at that time for us was a little closer to \$6 billion. The DOD helped us with the corporate decision to give us the bulk of that money, the bridge supplemental, as you say.

There are plenty of things that we could defer, but it is not smart to defer. We want to maintain our momentum for long, lead time orders and things like that to keep our reset going. So the bridge supplemental, as has been said, will allow us to do that. But it is not for the Army in the magnitude of \$12 billion something. It is less than half of that.

Mr. BROWNLEE. I also know, sir, in line with what you said, that there will be great care from the DOD, they have already told us, in going into the 2005 money to use in 2004. That is not going to be done lightly, I am told.

Chairman WARNER. I am going to step out with Senator McCain. Would you continue, and then I will be back to close out the hearing.

Senator SESSIONS [presiding]. General Mikolashek, with regard to General Karpinski's interpretation of a certain order, I want to clarify things a little bit so people are not left with confusion. As I understand it, her view was that an order from the command relieved her from responsibility of monitoring interrogations, and in fact she publicly stated that she could not go in that area of the prison.

You have answered that question. But it did not in any way have any language in it that suggested that any of these abuses would be approved. The disagreement was not that the order authorized abuses. It was simply whether she had responsibility over those abuses.

General MIKOLASHEK. Correct, or the command of her soldiers that remained intact, and that was not disputed.

Sir, Mr. Chairman, with your indulgence I would like to make one correction to a statement I made earlier. I mentioned that we talked to Colonel Pappas as part of our inspection. We did not.

Chairman WARNER [presiding]. In answer to my question you said that.

General MIKOLASHEK. We talked to Colonel Foster Payne, who is the current commander of the MI group out there, and Colonel Pappas was under inquiry at that time.

Chairman WARNER. The Procedure 15 inquiry.

General MIKOLASHEK. Yes, sir. Yes, sir.

Chairman WARNER. Those under the inquiry 15 Procedure, UCMJ, I can clearly understand why you did not try and question them.

General MIKOLASHEK. Yes, sir. Some of it had to do with the time of who was present and who was the commander at the time of our inspection.

Senator SESSIONS. Mr. Chairman.

Chairman WARNER. Go right ahead, Senator.

Senator SESSIONS. Slightly off the mark, for General Schoomaker.

When I was in Iraq over the 4th, General Abizaid in conversation—we were in a C-17 flying to Baghdad—shared with us his view that he did not want to put more soldiers in Iraq, that he believed it was critical for us to bring the Iraqi force up and for them to take responsibility. He thought it was the wrong step; it would send the wrong message if we thought we could just send in more forces to attack people.

Is that still his position and are you comfortable with that?

General SCHOOMAKER. Sir, first of all, I totally agree with that position. Second, I believe that is still his position.

Senator SESSIONS. I know Congress wants to be supportive, but we also need to listen to our commanders.

General SCHOOMAKER. Sir, the Secretary of Defense has made it very clear that what the commander asks for he will get. We are certainly constantly planning about all kinds of contingencies and what we will do in case he asks for more, or what are we going to do if we draw down, and all the rest of it. I subscribe to exactly that. If I were the commander on the ground, I would want exactly that same support.

Senator SESSIONS. He convinced me that we need, the Iraqis, the good people in Iraq, need to know they have to step up, that we are not going to continue. They can do it. They are going to do it. I was impressed with that, Mr. Chairman, the courage that the leaders are showing there. We met with the defense minister of Iraq. We met the top two generals in Iraq. They were impressive and determined and courageous. They are going to make this thing work.

General Petraeus met with us. He is training, helping train those soldiers. One of the little things I thought was good was that the defense minister referred to him as “Brother Petraeus.” They had a good personal relationship that can be successful in helping strengthen the Iraqi forces.

Chairman WARNER. Senator, I thank you very much.

Gentlemen, this will conclude the hearing. In my judgment, and several colleagues have shared with me, we have had an excellent hearing. I think it is terribly important that the American public and the world see that we address these matters in open, and we see the responses from those who are in charge. I commend each of you for what has been done by the Department of the Army to date, and I am reassured that you are going to continue to press on.

Thank you again.

The record will remain open for questions until close of business tomorrow.

The hearing is adjourned.

[Questions for the record with answers supplied follow:]

QUESTIONS SUBMITTED BY SENATOR CARL LEVIN

DETAINEE RIGHTS TO COMMUNICATE WITH THE INTERNATIONAL COMMITTEE OF THE RED CROSS (ICRC) UNDER ARMY REGULATION 190-8

1. Senator LEVIN. Secretary Brownlee, section 3-16 of Army Regulation 190-8 provides that prisoners of war have the right to “make complaints and requests to camp commanders and the ICRC . . . regarding the conditions of their internment.” That section further provides that detainees who exercise this right to complain to the ICRC may do so, among other ways, “in person to the visiting representatives of the ICRC. . . .” Did the DAIG investigate whether procedures were in place in OEF and OIF to fully implement detainee rights under section 3-16 of Army Regulation 190-8? If so, what were the DAIG’s findings regarding the implementation of section 3-16? If not, why not?

Secretary BROWNLEE. The DAIG inspected units involved in OEF and OIF to determine if procedures were in place to implement Enemy Prisoner of War and Civilian Internee rights in accordance with Army Regulation 190-8, chapters 3-16, 6-4, and 6-9. The inspection team observed that procedures were in place that allowed detainees, regardless of their classification, to lodge complaints to camp commanders through several different methods. Internee committees had been established at the internment/resettlement (I/R) facilities that permitted members to forward complaints on behalf of other civilian internees. I/R commanders at Camp Bucca and Abu Ghraib had established weekly meetings with committee members to improve communication. The inspection team observed unsupervised ICRC interviews with detainees at the Bagram I/R facility. At a Mosul brigade collecting point, the inspection team observed city council members visiting with detainees offering another opportunity for detainees to make complaints. Additionally, through interviews and sensing sessions with leaders and soldiers, the team found that detainees have the opportunity and did communicate regularly, one-on-one, with guards and interrogators to pass complaints through the chain of command. At collecting points, this was the primary means of communicating complaints to the commander.

2. Senator LEVIN. Secretary Brownlee, section 3-16 also requires that “If [the] ICRC . . . communicates directly with an Enemy Prisoner of War/Counterintelligence (EPW/CI) camp commander about any matter requiring an answer, the communication and commander’s reply will be forwarded to Headquarters, Department of the Army; Office of the Deputy Chief of Staff, Operations and Plans (HQDA, ODCSOPS) Department of the Army, Military Operations-ODL (DAMO-ODL) National Prisoner of War Information Center (NPWIC), for proper action.” The Army IG Report says that the Office of the Provost Marshal General has redesignated the NPWIC as the National Detainee Reporting Center (NDRC). [p. 56] Did the Army IG Report investigate whether any ICRC communications with camp commanders, or any replies to such communications, were forwarded to the NDRC? If so, what were the IG’s findings? If not, why not?

Secretary BROWNLEE. During the inspection, the Army Inspector General team determined that no ICRC facility inspection reports addressed to camp commanders had been forwarded to the NDRC.

CONTRACT INTERROGATORS

3. Senator LEVIN. Secretary Brownlee, an Army memorandum dated December 26, 2000, and still in effect today made the express determination that gathering tactical intelligence is an inherently governmental function. The memorandum states that “intelligence at the tactical level is integral to the application of combat power by the sovereign authority.” The memorandum concludes: “At the tactical level, the intelligence function under the operational control of the Army performed by military in the operating forces is an inherently governmental function barred from private sector performance.” Office of Management and Budget (OMB) Circular A-76 expressly states that agencies “shall . . . Perform inherently governmental activities with government personnel.” At the hearing, you testified that “if these functions are performed by contract interrogators under an entity, which in this case was Central Command, or CJTF-7 specifically, then they would not be considered inherently governmental.” What specific language in the December 26, 2000, memorandum do you read as establishing an exception for functions performed under Central Command or CJTF-7?

Secretary BROWNLEE. The December 26, 2000, memorandum from the Assistant Secretary of the Army for Manpower and Reserve Affairs to the Assistant Deputy Chief of Staff for Intelligence states in the first paragraph that “[m]y determinations

do not apply to Army assets under the operational control of other Defense activities or executive agencies.”

4. Senator LEVIN. Secretary Brownlee, do you agree or disagree with the statement in the memorandum that “intelligence at the tactical level is integral to the application of combat power by the sovereign authority”? If you agree with this statement, on what basis do you believe that it is appropriate to contract out this function?

Secretary Brownlee. I agree with the statement in the December 26, 2000, memorandum from the Assistant Secretary of the Army for Manpower and Reserve Affairs (ASA M&RA) to the Assistant Deputy Chief of Staff for Intelligence that “intelligence at the tactical level is integral to the application of combat power by the sovereign authority.” The tactical level refers to the level of war at which battles and engagements are planned and executed to accomplish military objectives assigned to tactical units of forces. Thus, intelligence gathering at the tactical level is performed as part of a combat operation. However, the ASA M&RA policy memorandum states that operational and strategic level intelligence functions are not inherently governmental. The policy allows for outsourcing operational and strategic level intelligence functions in situations where there are not enough military and civilian in-house employees to perform the function. Intelligence gathering at the Abu Ghraib prison is considered at the operational or theater level as opposed to the tactical level. Therefore, contracting out the interrogator function at the prison did not violate the December 26, 2000, policy memorandum. That said, the Army is currently reexamining its inherently governmental and policy decisions in the intelligence area and would like to build additional force structure so that operational and theater level intelligence functions will be performed in-house in the future. Additionally, we will explore the possibility of having civilian employees perform this function.

5. Senator LEVIN. Secretary Brownlee, you also testified that a contract interrogator “is supposed to work under the direct supervision of an officer or noncommissioned officer who would be the supervisor of that person.” Section 37.104 of the Federal Acquisition Regulation defines a “personal services contract” as a contract in which “contractor personnel are subject to the relatively continuous supervision and control of a Government officer or employee.” The same section states that: “The Government is normally required to obtain its employees by direct hire under competitive appointment or other procedures required by the civil service laws. Obtaining personal services by contract, rather than direct hire, circumvents those laws unless Congress has specifically authorized acquisition of the services by contract.” In light of your statement that contract interrogators are under the “direct supervision” of government personnel, it would appear that these personnel are “subject to the relatively continuous supervision and control of a Government officer or employee.” Do you agree or disagree?

Secretary BROWNLEE. The contract under which the government obtained intelligence services changed as of August 9, 2004. Since that date, the services are being obtained through a personal services contract that was awarded by the Army Contracting Agency. The personal services contract, awarded pursuant to the statutory authority granted to the military departments by title 10 U.S. Code, Section 129b, permits the contract employees to be under the direct supervision of Multinational Forces-Iraq personnel and it also includes higher personnel qualification standards than did the previous contract vehicle. The change to a personal services contract was made in order to provide more positive controls over the contractor’s employees in the performance of their intelligence support services. The Assistant Secretary of the Army (Acquisition, Logistics, and Technology) approved the personal services aspect of the contract on July 30, 2004.

6. Senator LEVIN. Secretary Brownlee, in your view, was this contract a personal services contract? If so, why is the contract not prohibited by section 37.104 of the Federal Acquisition Regulation?

Secretary BROWNLEE. We understand that the contract through which intelligence support services were obtained prior August 9, 2004, was a non-personal services contract. The supervisory responsibility was performed by the contractor’s supervisory chain. Therefore, we believe that this contract did not violate FAR 37.104.

7. Senator LEVIN. Secretary Brownlee, do you agree or disagree with the statement in section 37.104 of the Federal Acquisition Regulation (FAR) that the government should be “required to obtain its employees by direct hire under competitive appointment or other procedures required by the civil service laws”? If you agree

with this statement, on what basis do you believe that it is appropriate to contract out this function?

Secretary BROWNLEE. I agree with FAR 37.104(a) that “[t]he Government is normally required to obtain its employees by direct hire under competitive appointment or other procedures required by the civil service laws.” FAR 37.104(b) states that, “[a]gencies shall not award personal services contract unless specifically authorized by statute.” With respect to the current intelligence support services contract, the specific statutory authority to award a personal services contract is title 10 U.S. Code, section 129b(d)(1) (A) or (B). Use of this authority is amply justified by the circumstances. If the Army were to hire employees to perform these tasks, I agree that competitive civil service procedures should be followed. However, in this case the government was obtaining intelligence support services. Over the past year, the intelligence operations support has proven to be essential to national defense. These services enable effective collection and distribution of intelligence directly supporting military operations. We believe that the lives of several coalition forces personnel have been saved based on the intelligence data collected and distributed throughout multinational forces-Iraq (MNF-I). The preponderance of the intelligence services provided support the collection, analysis, and dissemination of HUMINT. In MNF-I, U.S. Forces are not adequately staffed to manage the amount of HUMINT operations required for daily operations. Without these vital intelligence services, the coalition, at all levels, would lose a large portion of HUMINT capability, essential to conducting military operations. The use of contractor provided intelligence support, allows military personnel to execute HUMINT operations from forward operating bases. Without the additional intelligence support, military personnel would have to remain in base camps, hampering effective intelligence collection and analysis operations. In addition, the Department of Defense does not have an adequate number of personnel available to execute the critical intelligence support at the current level necessary to support MNF-I. The vast intelligence collection requirements, needed to properly support the theater has stretched the military intelligence military occupational specialty field to capacity and requires additional, skilled personnel, to assist the military in collection, analysis, and dissemination of intelligence products.

QUESTIONS SUBMITTED BY SENATOR BILL NELSON

TRAINING AND LEADER DEVELOPMENT

8. Senator BILL NELSON. Secretary Brownlee and General Schoomaker, I recall press reports of detainee abuse involving an Army battalion participating in peace enforcement operations in Kosovo from September 1999 to March 2000. Apparently soldiers and some leaders of this battalion were involved in misconduct and abuses of authority including unauthorized interrogations, inappropriate handling of females, threatening detainees with the use of weapons, and, although not a detainee incident, one soldier committed a rape and murder. Investigations by the Army suggested that the chain of command failed to appropriately train the unit for a peacekeeping mission, exceeded their authority in aggressively favoring one faction over another, and tolerated misconduct by members of the unit. According to investigators, the battalion’s command climate fostered actions by troops that, “violated the limits and terms of their military assignments by intimidating, interrogating, abusing, and beating Albanians.”

Detainee abuse in Iraq and Afghanistan echoes the incidents reported in Kosovo, with the clear exception of the more dangerous and stressful conditions of combat versus peace enforcement operations. This begs questions, however, about how the Army may have used the lessons of Kosovo and will use the lessons of Iraq and Afghanistan to better prepare leaders and soldiers for the realities of military operations today and tomorrow.

Press reports at the time of the Kosovo situation indicate that the Army ordered detainee treatment training for U.S. based units. Can you determine if this training specifically used the incidents in Kosovo as an illustration of what soldiers should not do and what leaders should not allow to happen?

Secretary BROWNLEE and General SCHOOMAKER. The training of soldiers following the Kosovo incident incorporated the Army’s experience with peacekeeping operations from the Sinai to the long-term missions conducted in the Balkans. This was mandatory for all units before deploying on future peacekeeping missions. The training was a 2-week long peacekeeping scenario that forced soldiers to operate under the realistic conditions they would encounter in a likely peacekeeping role versus operating under a traditional combat role with a known enemy. The training took

place at the Combat Training Centers, either at the Combat Maneuver Training Center in Hohenfels, Germany, or the Joint Readiness Training Center at Fort Polk, Louisiana. The training was formalized as a "Mission Rehearsal Exercise" in a peacekeeping role. Through the use of role players and translators, the soldiers were forced to deal with an unstable environment of opposing sides and multiple problems. The soldiers had to sort through the problems while facing escalating threats and take the appropriate action to solve those threats.

Through the use of feedback by the observer controllers, the soldiers received after action reviews of the actions they took to determine any strengths or weaknesses and to include any consequences of the decisions made from their actions. Placing the soldiers under these varying conditions addressed the similar shortfalls noted by the battalion involved in the Kosovo abuse, which had difficulty transitioning from a combat role to a peacekeeping role. Furthermore, Military Police units conducting detainee operations in Kosovo requested and received correctional specialists who provided technical and training expertise on how to maintain and improve the overall operations of a detention facility, especially with regard to the care and treatment of detainees within those facilities. The assistance teams deployed to Kosovo worked with the Military Police in improving the detention and correctional operations until a Military Police Reserve component unit with enemy prisoner detention skills arrived and assumed the detention mission.

9. Senator BILL NELSON. Secretary Brownlee and General Schoomaker, if specific examples were not use, can you explain why not?

Secretary BROWNLEE and General SCHOOMAKER. Specific examples of proper and improper ethical behavior are routinely used in training our soldiers and leaders on the Law of War. The Kosovo incident has been used in classroom discussion and as part of reading lessons during the leadership instruction at Fort Leavenworth, Kansas where we train our brigade and divisional level staff officers (normally at Major rank). Additionally, the U.S. Army Europe and The Center for Army Lessons Learned retained lessons learned from the Kosovo incident. Both had copies of after action reports of not only the incident from the 82nd Airborne Division, but that of the operational challenges and solutions worked through by Task Force Falcon in detention operations while serving in Kosovo.

10. Senator BILL NELSON. Secretary Brownlee and General Schoomaker, was the detainee treatment training directed by the Army in 2000 integrated into long-term Army training requirements and plans? If not, why not?

Secretary BROWNLEE and General SCHOOMAKER. The Army instituted an intense 2-week peacekeeping Mission Rehearsal Exercise conducted at the Combat Maneuver Training Center (CMTC) for peacekeeping missions in Kosovo, the Sinai, and the Balkans. Using a mock-up of an urban setting in these CMTCs, soldiers previously trained for high intensity combat learned about conflict resolution, group dynamics and graduated levels of force in response to various provocations. The investigation into the Kosovo incident pointed to a failure of leadership as the primary problem. It was also noted that the battalion where the incident occurred received its deployment orders late in its training cycle and did not receive a peacekeeping mission rehearsal exercise. The investigation reported that the soldiers had difficulty adjusting from a combat mentality to one required for the complexities of peacekeeping. The soldiers undergoing the peacekeeping mission rehearsal exercise experienced the complexity working through various problems and applying escalating levels of force depending on the circumstances. The Army continues to refine the scenarios at our Combat Training Centers by deploying mobile training teams with knowledge of detainee lessons learned to assist other units during their training. The mobile training teams also provide valuable experience and expertise to improve the quality of training at the Combat Training Centers. This improvement incorporated brigade level detainee holding areas into the tactical scenarios that are based on lessons learned in Iraq. Additionally, our soldiers and leaders training at the Combat Training Centers received increased feedback from an increased number of observer evaluations of detainee operations. Our Combat Training Centers have also increased the use of combat veterans with experience in detention operations and role players speaking Arabic to train help soldiers who will be deploying to Iraq and Afghanistan.

11. Senator BILL NELSON. Secretary Brownlee and General Schoomaker, was or is the Kosovo situation used as a case study, as is often done with the case of My Lai during the Vietnam War, in either training or leader development courses in the Army's institutional training and professional development and education systems? If so, where and how? If not, why not?

Secretary BROWNLEE and General SCHOOMAKER. The Kosovo incident involving A Company, 3rd Battalion, 504th Parachute Infantry is not used as a stand-alone case study. However, it has been used in classroom discussion and reading during leadership instruction at Fort Leavenworth, Kansas, where we train our brigade and division level staff officers (normally at Major rank). As the incident was reported, the leadership instructors incorporated the information into ongoing instruction on ethical decisionmaking and building command climate. The Kosovo situation was also incorporated into a 3-hour lesson in an elective on leadership in battle. This 3-hour lesson centered on My Lai and drew on the Kosovo incident to show relevance to modern day operations. In addition, Military Review published an article in March/April 2001, which discussed the negative aspects of cohesion. This article, although it centered on My Lai, mentioned the Kosovo incident as a possible contemporary example. Currently we teach a 2-hour lesson on war crimes and ethical decision-making in combat. We use the war crimes committed at My Lai as the case study. Students are required to read 27 pages from Lieutenant General William Peers' book on the inquiry into My Lai. These pages specifically focus on the nine factors that contributed to the tragedy. The class discussion centers on how these factors can be found in today's contemporary operating environment. During this class discussion last year, information from the recent prison incident was used and analyzed according to LTG Peers' factors. As part of this discussion, the Kosovo incident as well as other incidents from Operation Iraqi Freedom come up and are discussed in some classes. Ultimately, students determine that the root cause of the war crimes committed at My Lai or the Kosovo incident can be found in the values a cohesive group establishes and in the command climate that fails to establish the proper conditions for the inculcation of the Army's values. Students also discuss how they can foster a climate and establish systems that prevent the factors identified by LTG Peers from influencing the values and behaviors of their units and how they can positively impact the formation of cohesive groups. Regardless of the case studies used, the goal is to determine the root cause, apply it to today and understand the actions required to prevent it from occurring.

12. Senator BILL NELSON. Secretary Brownlee and General Schoomaker, will the lessons learned from Iraq and Afghanistan be integrated into the Army's institutional training and leader development and education systems? How and on what time line?

Secretary BROWNLEE and General SCHOOMAKER. Yes, the lessons learned from both Operation Iraqi Freedom and Operation Enduring Freedom have already been incorporated into ongoing institutional training of our soldiers and their leaders. The U.S. Army Center for Lessons Learned (CALL), a subordinate unit of the U.S. Army Training and Doctrine Command, collects and analyzes data and information from a variety of current and historical sources, including Army current operations and training events, and produces lessons for military commanders, staffs, and military schools. Dedicated collection teams conduct focused data collection and observations from ongoing operations in Iraq and Afghanistan based on guidance from Headquarters, Department of the Army and commanders. These observations are analyzed and lessons derived. The lessons are then disseminated to the Army through a variety of print and electronic media, including the CALL Army Web page. The web page provides access to articles, publications, and procedures developed from lessons learned, and research materials. This training includes individual and collective training tailored to the specific theater to include country orientations, antiterrorism/force protection, rules of engagement, weapons qualification, unexploded ordnance and improvised explosive device training, land navigation, combat stress and suicide awareness, individual movement techniques, combat lifesaver training, and introduction to detainee operations. Individual leaders also receive training to understand the military, political, cultural, economic and religious environment of a specific theater. Brigade and division leaders are encouraged to attend a 5-day cultural awareness seminar provided by the Jordanians. Additional training also includes using an interpreter/translator, performing negotiations, supervising convoy operations, employing non-lethal capabilities, supervising the rules of engagement and its application, conducting medical evacuation and performing risk management, supervising traffic control, cordon and search procedures, crowd control, enforces the Law of War, and supervising the handling of enemy personnel. Additional mission training is tailored for units at each echelon of command based on real-world lessons learned and allowing them to conduct a multitude of likely missions they will encounter in Afghanistan or Iraq.

[Whereupon, at 1:16 p.m., the committee adjourned.]

THE INVESTIGATION OF THE 205TH MILITARY INTELLIGENCE BRIGADE AT ABU GHRAIB PRISON, IRAQ

THURSDAY, SEPTEMBER 9, 2004

U.S. SENATE,
COMMITTEE ON ARMED SERVICES,
Washington, DC.

The committee met, pursuant to notice, at 9:39 a.m., in room SH-216, Hart Senate Office Building, Senator John Warner (chairman) presiding.

Committee members present: Senators Warner, McCain, Inhofe, Allard, Sessions, Collins, Talent, Graham, Levin, Kennedy, Lieberman, Reed, Bill Nelson, E. Benjamin Nelson, Dayton, and Pryor.

Committee staff members present: Judith A. Ansley, staff director; and Leah C. Brewer, nominations and hearings clerk.

Majority staff members present: Charles W. Alsup, professional staff member; Regina A. Dubey, research assistant; Ambrose R. Hock, professional staff member; Gregory T. Kiley, professional staff member; Lynn F. Rusten, professional staff member; and Scott W. Stucky, general counsel.

Minority staff members present: Richard D. DeBobes, Democratic staff director; Daniel J. Cox, Jr., professional staff member; Maren R. Leed, professional staff member; and William G.P. Monahan, minority counsel.

Staff assistants present: Catherine E. Sendak, Bridget E. Ward, Nicholas W. West, and Pendred K. Wilson.

Committee members' assistants present: Christopher J. Paul, assistant to Senator McCain; John A. Bonsell, assistant to Senator Inhofe; Darren M. Dick, assistant to Senator Roberts; Arch Galloway II, assistant to Senator Sessions; Lindsey R. Neas, assistant to Senator Talent; Clyde A. Taylor IV, assistant to Senator Chambliss; Meredith Moseley, assistant to Senator Graham; Christine O. Hill, assistant to Senator Dole; Russell J. Thomasson, assistant to Senator Cornyn; Mieke Y. Eoyang, assistant to Senator Kennedy; Erik Raven, assistant to Senator Byrd; Frederick M. Downey, assistant to Senator Lieberman; Elizabeth King, assistant to Senator Reed; Davelyn Noelani Kalipi and Richard Kessler, assistants to Senator Akaka; William K. Sutey, assistant to Senator Bill Nelson; Eric Pierce, assistant to Senator E. Benjamin Nelson; Mark Phillip Jones, assistant to Senator Dayton; and Andrew Shapiro, assistant to Senator Clinton.

**OPENING STATEMENT OF SENATOR JOHN WARNER,
CHAIRMAN**

Chairman WARNER. Good morning, everyone.

The committee meets today to receive testimony on the investigation of the 205th Military Intelligence (MI) Brigade at Abu Ghraib Prison in Iraq, commonly referred to as the Fay-Jones Report.

We welcome our witnesses: General Paul Kern, United States Army, appointing officer for the investigation; Lieutenant General Anthony R. Jones, investigating officer; Major General George Fay, investigating officer; Major General Anthony Taguba, investigating officer concerning the detainee abuse by members of the 800th Military Police Brigade at the prison; and Major General R. Steven Whitcomb, United States Army, Special Assistant to the Commander of Central Command, representing the command responsible for acting on the majority of the recommendations that are flowing from this investigation and how they are being implemented.

General Fay was originally appointed as the investigating officer by General Sanchez and was tasked with investigating allegations that members of the 205th Military Intelligence Brigade were involved in detainee abuse at the Abu Ghraib detention facility and whether military intelligence personnel comported with established interrogation procedures and applicable laws and regulations.

General Fay's investigation was subsequently augmented by the addition of Lieutenant General Jones as an investigating officer. General Jones was charged with focusing on whether organizations or personnel higher than the 205th Brigade chain of command or events and circumstances outside of the 205th Military Intelligence Brigade were involved directly or indirectly in the activities regarding alleged detainee abuse at the prison.

I commend each of you for your professional performances to date. Speaking for myself, I think they meet the highest standards of Army traditions. It was not an easy task, but in the judgment of this Senator, you performed it very commendably.

I would like to review for the committee that this committee initiated the series of hearings in Congress. I thank the members of the committee for the support they have given me, Senator Levin, and others, as we proceed with our numerous hearings on this very important subject. As a consequence I think somewhat of the initiatives taken by this committee, the executive branch, under the direction of the President, the Secretary of Defense, the acting Secretary of the Army, and others, have initiated 11 senior level investigations. Copies of eight of these reports have been received by the committee. Of the remaining three ongoing investigations or reviews, two should be completed later this month. The final one should be completed by December. Over 17,000 pages of documentation have been received to date by the committee. In my years on the committee, over a quarter of a century, I believe this is an unprecedented amount of information for this committee to have received as a direct consequence of the initiatives of the committee and I say commendation to the executive branch for their prompt attention to this very serious issue.

We began this series of hearings on the events at the prison on May 7, immediately after all the allegations of prisoner abuse sur-

faced. As I said at that first hearing, the events at the prison represent a serious case of military misconduct, as serious as I had ever seen in the many years I have had the privilege of associating with the men and women of the United States military. This is simply not the way for anyone, any individual or group of individuals who have the privilege of wearing the uniform of the United States of America to conduct themselves. I know that all of our witnesses today agree with that statement. I remember so well in our briefing, General Kern, you drew upon your extensive experience in the uniform that you proudly wear and commented much to that effect.

Trials are still going on. Several have already been tried and sentenced or have accepted nonjudicial or administrative punishment. In addition, 11 senior level reviews of detainee operations of detainee abuse throughout the Department of Defense (DOD) were initiated. Seven of those reviews have been completed, as I reported here.

I think the combination of the actions by Congress—and I note with some interest that the House of Representatives today, the committee of jurisdiction, the Armed Services Committee, is having identical hearings. This panel appears before the House this afternoon, as we this afternoon hear from the civilian panel of the two former Secretaries of Defense: Schlesinger and Brown.

So I think Congress has done its job thus far, but more remains to be done to assess, in particular, the thoroughness of these reports, to determine whether any significant portion of the investigation is left to be done, and also to assess the accountability. Now, when I say “assess the accountability,” I mean to indicate to those people from the Commander in Chief, the President, on down the actions that we deem appropriate to establish that level of accountability that may have not been taken thus far.

We will ask your professional judgment as to the thoroughness you individually and collectively believe with regard to the investigations to date. You have invested the better part of your lives proudly wearing that uniform, and you have participated in these investigations with the intent of determining what the facts are and how best never to let the Army, which you proudly serve, ever experience this again.

Findings contained in the investigation before us this morning are troubling. The investigation identifies cases of individual criminal behavior, abuses conducted by soldiers who knew or should have known they were violating the prescribed rules and doctrine of the United States Army, cases of abuse which resulted from some confusion, nevertheless, over the doctrine and policies that were promulgated and certain leadership failures. All of these factors were at play at the Abu Ghraib Prison.

Several conclusions contained in this investigation are particularly instructive and help put the abusive behavior in context.

First, the primary causes of the violent and sexual abuses were relatively straightforward. Individual criminal misconduct, clearly in violation of law, policy, and doctrine, and contrary to every value which the United States Army has been proudly holding all these many years.

Second, not all of the violent or sexual abuses occurred separately from scheduled interrogations and did not focus on the persons held for intelligence purposes.

Finally, according to one of the investigation's major findings, neither defense nor Army doctrine is really the root cause of any of these abuses. Abuses would not have occurred had doctrine been followed and mission training conducted. This investigation, its predecessor reviews, and the report of the Schlesinger panel we will receive later today all conclude that no approved procedures, policy, doctrine, or training called for, allowed, or encouraged the kind of abuses that we have witnessed.

Our job this morning is to examine why then did these abuses occur and what must be done to prevent them from ever occurring again.

We also will have later reports about Afghanistan. As we continue to assemble the facts concerning the allegations of detainee abuse at Abu Ghraib and elsewhere, it is important that we keep these incidents in context. Any instance of abuse is unacceptable, and we all have been disappointed to hear of over 300 allegations of abuse of prisoners in Iraq and Afghanistan. As of mid-August, 66 allegations of abuse had been substantiated, and one-third to one-half of those incidents occurred at the point of capture during transit, often in the heat of battle. Over the past 3 years, the U.S. has apprehended over 50,000 personnel in Iraq and Afghanistan. Thousands of soldiers, sailors, airmen, and marines have done their job courageously, humanely, and honorably. So, the misdeeds of a few have to be judged against the vast 99.9 percent performing their duties in a commendable way.

Today's GI, like those who preceded him or her, is a symbol of hope to the world and the overwhelming majority fully understand the difference between right and wrong, both from their upbringing and from their military training.

I also would like to touch on today, for you to give your personal view, as to the consequence that flowed from these incidents, then the investigations as to whether it has degraded in any way our ability to have the essential, ongoing intelligence collection, provide that information which is absolutely needed for primarily our tactical forces, and whether that pendulum, as a consequence of these incidents and the series of investigations, may have gone too far and in any way have degraded that collection system.

Senator Levin.

STATEMENT OF SENATOR CARL LEVIN

Senator LEVIN. Thank you, Mr. Chairman. First, let me join you in thanking our panelists for their service to our Nation in helping us sort out these abuses, but far more importantly, for their life-long commitment to service to this Nation. We are indebted to each and every one of you.

Thank you, Mr. Chairman, for your leadership and your initiative in trying to get these matters before us, to get them thoroughly examined and to get them understood. As you point out, we have a ways to go, but at least we have started this process. It is because of your initiative that we have started this process, and we are all grateful to you for it.

This is a subject that needs the most important, thorough, and objective review. It is important for our Nation that this review take place. It is important for our Army, for our military and for all of us that we make it clear by a willingness to publicly face up to what has occurred, that we are unwilling to accept this kind of conduct as a people or as a military. That is the greatest proof that we can provide that what happened here is not us. It is not our military. It is not our Nation. Our willingness to look straight in the eye at these abuses, to find out the sources of them, and to try to hold people accountable for them, is the best way in which we can truly support what this Nation stands for and prove that the values and the standards that we stand for were not those that were implemented at Abu Ghraib during these violations.

The findings of the Fay report should put to rest the contention that abuses at Abu Ghraib were simply the aberrant behavior of a few military police reservists on the night shift. The Fay report cites 27 soldiers of the 205th MI Brigade for requesting, encouraging, condoning, or soliciting military police personnel to abuse detainees or participating in such abuse or violating established interrogation procedures and applicable laws and regulations during interrogations at Abu Ghraib. General Fay cites an additional 17 military intelligence soldiers or contractors who used unauthorized or improper harsh interrogation techniques such as clothing removal, improper isolation of detainees, and the use of dogs. General Fay identifies over 40 separate alleged instances of detainee abuse committed by soldiers and civilian contractors.

The direct causes of these incidents of abuse identified in the Fay report include a number of factors; including the failure of the leaders and soldiers of the 205th MI Brigade to impose discipline, a leadership failure at multiple echelons within Combined Joint Task Force-7 (CJTF-7) and the misconduct of a small group of "morally corrupt soldiers and civilians."

But beyond these direct causes of abuse, the Fay report identifies a number of "systemic problems and issues" that contributed to an environment conducive to abuse. This finding contrasts with the conclusions of the Army Inspector General's report issued in June of this year which said that he could not identify any system failures that resulted in incidents of abuse in Iraq or Afghanistan. The Fay report contains 24 findings and 2 observations regarding systemic failures. Among these systemic failures are inadequate interrogation doctrine and training, severe shortages in MP and MI personnel, ambiguous lines of responsibility between MI and MP chains of command, and the presence of a number of confusing and constantly changing interrogation policies in Iraq.

I would like to just highlight a couple of General Fay's findings which I hope will be specifically addressed in their testimony this morning. First, he has found that "leaders failed to take steps to effectively manage pressure placed upon" personnel at the Joint Interrogation and Detention Center at Abu Ghraib. The Fay report explains that the military Intelligence Community felt that intense pressure from "higher headquarters, to include Central Command (CENTCOM), the Pentagon, and the Defense Intelligence Agency (DIA) for timelier, actionable intelligence" was adversely affecting their decisionmaking at the interrogation facility. This pressure

took the form of requests for information being passed down to the lowest levels at Abu Ghraib from numerous headquarters without being prioritized by leaders. General Fay will hopefully address the question of who at higher headquarters was bringing this pressure and how this pressure impacted intelligence operations at Abu Ghraib.

Another finding of the Fay report that requires further exploration is the impact of national policies and DOD guidance in contributing to confusion among soldiers at Abu Ghraib. The report finds that "DOD's development of multiple policies on interrogation operations for use in different theaters or operations confused Army and civilian interrogators at Abu Ghraib." It adds, by way of explanation, that "national policy and DOD directives were not completely consistent with Army doctrine concerning detainee treatment or interrogation tactics." The root of this confusion is the administration's decision in early 2002 that al Qaeda and Taliban personnel would not be entitled to prisoner of war status under the Geneva Conventions. This led to the development of harsh interrogation techniques going beyond established Army doctrine for use at Guantanamo Bay. How did these policies and interrogation techniques, including the use of stress positions, isolation for up to 30 days, removal of clothing, and the use of detainees' phobias such as the use of dogs, come to be incorporated in CJTF-7 interrogation policy guidance for use in Iraq, where the Geneva Conventions were to be applied from the beginning of the conflict? To what extent did the higher-level promulgation of national and DOD policies, inconsistent with Army doctrine, contribute to the abusive environment at Abu Ghraib?

In looking at causes beyond the chain of command of the 205th MI Brigade, General Jones finds that senior level leaders, while not involved in directing the abuses, did bear some responsibility. He points to a lack of oversight at the Abu Ghraib detention facility, a failure at the CJTF-7 level to respond adequately to indications and warnings of possible abuses, including reports of the International Committee of the Red Cross (ICRC), and the issuance by CJTF-7 of unclear and inconsistent policy guidance regarding the conduct of interrogations.

Among other contributing factors identified by General Jones was the under-resourcing of CJTF-7 headquarters. The failure to approve a CJTF-7 joint manning document, the document which establishes the number and types of personnel required to staff the CJTF-7 headquarters, contributed to it being severely under-resourced during the period in question. The Jones report finds that this lack of resources and staffing degraded the ability of CJTF-7 staff to oversee operations at Abu Ghraib. Why were they under-resourced? Who had decided or assumed that the end of major hostilities would be followed by a non-violent aftermath? Why did it take senior leadership so long to act once the insurgency became apparent?

Another contributing factor identified in the Jones report is the presence of other Government agencies (OGA) which is an euphemism for the Central Intelligence Agency (CIA), at the DOD-run detention facilities. The Jones report finds that "there was at least the perception, and perhaps the reality, that non-DOD agencies

had different rules regarding interrogation and detention operations. Such a perception encouraged soldiers to deviate from prescribed techniques." That raises the question of what were the rules governing OGAs at DOD-run facilities and how are those officials going to be held accountable for abusive behavior in violation of established procedures?

While the different aspects of the prisoner abuse issue have been or are being addressed piecemeal through the various DOD investigations to date, this committee is still missing significant information necessary to fully understand where responsibility lies for the abuse of prisoners in U.S. custody. I expect that we will get some of that information or a better sense of that when we receive testimony this afternoon from the Schlesinger panel, but there is much beyond that, as our chairman has pointed out. Again, I want to thank our chairman for his determination to get a thorough and objective review of the incidents and the abuses against prisoners at Abu Ghraib.

Chairman WARNER. Thank you very much, Senator Levin. I acknowledge your strong support from the first, as well as the members of this committee. We could not have done our work without unity among our committee.

Very well, General Kern. We are ready to hear from you.

STATEMENT OF GEN PAUL J. KERN, USA, COMMANDING GENERAL, UNITED STATES ARMY MATERIEL COMMAND; ACCOMPANIED BY LTG ANTHONY R. JONES, USA, DEPUTY COMMANDING GENERAL, CHIEF OF STAFF, UNITED STATES ARMY TRAINING AND DOCTRINE COMMAND; MG R. STEVEN WHITCOMB, USA, SPECIAL ASSISTANT TO THE COMMANDER, UNITED STATES CENTRAL COMMAND; MG GEORGE R. FAY, USA, DEPUTY COMMANDER, UNITED STATES ARMY INTELLIGENCE AND SECURITY COMMAND; AND MG ANTONIO M. TAGUBA, USA, DEPUTY ASSISTANT SECRETARY OF DEFENSE FOR RESERVE AFFAIRS, READINESS, TRAINING, AND MOBILIZATION

General KERN. Thank you, Mr. Chairman. With your permission, I will submit my formal testimony for the record and summarize using these charts.

Chairman WARNER. Without objection, the testimony in complete form of all witnesses will be accepted into the record.

General KERN. Thank you.

I would like to restate the people who are at the table with me just so that everyone knows. General Whitcomb, former Chief of Staff of CENTCOM, is representing CENTCOM here today and is still part of the CENTCOM headquarters. He brought with him, behind him, Colonel Quantock, who is the 16th MP Brigade, Military Police Brigade, who now is responsible for the detention operations, and we had visited with him at Abu Ghraib about a month ago. General Fay is the Deputy to the Army's intelligence staff officer, the G-2 of the Army, and is one of our chief investigators, as you pointed out. General Jones, to my left, is the Deputy Commanding General of the Training and Doctrine Command, the other senior investigator. Major General Taguba, formerly part of our 3rd Army and the Land Component Commander now on the OSD staff,

whose report you have heard previously as part of the focus on the Military Police Brigade. We are all prepared to answer questions today, and we, Senator Levin, clearly understand the issues that you laid out and we will do our best to address them in our testimony today.

I would like to start, if I could, by the comment that all of us are bound by values. We believe in them. Whether it is our source of commission or whether it is our upbringing in the United States Army, the set of values that we have been trained to follow are a creed which we believe in and we are very proud of people who follow them. We are here today to report to you about some people who failed to meet those standards. That is very unfortunate and that is something which we have taken strong actions to correct within the United States Army. Those actions which are underway have corrected them and we will be able to report to you today many improvements, from what we report in this period of the investigation, have already taken place.

The second point I would make is that we all represent strong operational backgrounds, as well as functional backgrounds. So, we respect the conditions of which they are being reported to you for the people who were operating in Iraq at the time of these abuses.

If I could go to the first chart, we will summarize one of the issues which you laid out which is the hierarchy of the many ongoing investigations, to put into perspective what we are reporting to you today and some of the gaps that are to be filled.

[The chart referred to follows:]

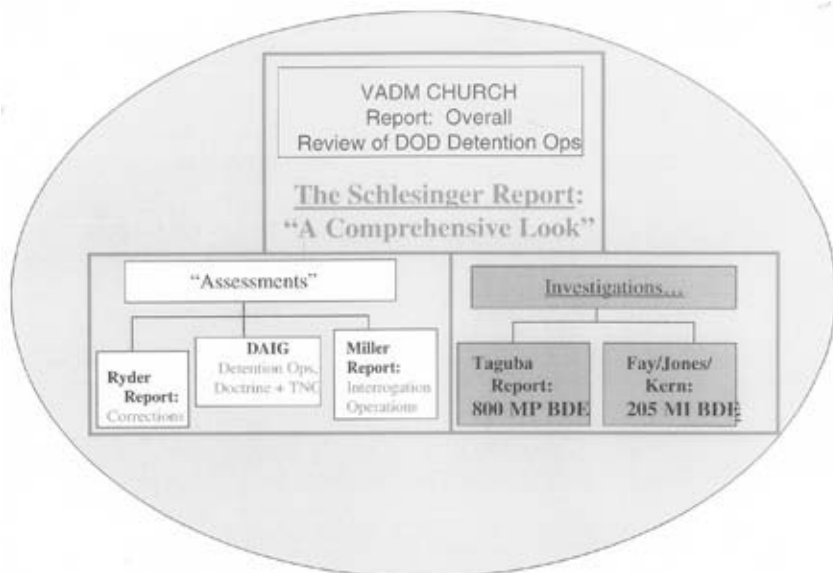

INVESTIGATIVE METHODOLOGY

- IN EXCESS OF 9,000 DOCUMENTS COLLECTED, CATALOGUED AND ARCHIVED
- OVER 170 INTERVIEWS CONDUCTED
- 8 INVESTIGATIVE VISITS TO IRAQ
- INVESTIGATIVE TEAMS CONSISTED OF 28 PERSONNEL TO INCLUDE INVESTIGATORS, ANALYSTS, SUBJECT MATTER EXPERTS AND LEGAL ADVISORS
- INDEPENDENT REVIEW TEAM CHARTERED BY APPOINTING AUTHORITY

First, we did not go back and redo the previous assessments and investigations, but we used them as part of our assessment, our investigation, and our evaluation. So the Ryder report, which focused on our military police and detention operations, was part of that and the Department of the Army Inspector General report, which you referred to. We both reviewed their entire report and listened to their comments. The Miller report, which is an assessment of how we could learn from the detention operations at Guantanamo and the integration of detention and interrogations was part of our assessment. We spent a great deal of time studying and discussing with Major General Taguba his previous assessment of Abu Ghraib with the Military Police Brigade. All of these were inputs and are contained in many excerpts to our investigation.

Additionally, we shared all of our information with the Schlesinger panel, whom you will hear from this afternoon, and they were fully briefed on all of our findings as we developed our investigation.

Admiral Church, who is the Inspector General of the U.S. Navy, was appointed to fill the gaps. His report is still due. We expect it towards the end of this month. He also has been apprised of all of the information which we have provided and his personnel have been part of our team as we went through our review of the investigation.

I would like to summarize quickly the methodology which we used. We believe it was thorough. We believe it was well-documented. This investigation took part under what is called a Procedure 15, which is the method by which we review intelligence operations. It was done in accordance with an Army regulation 15-6, which prescribes that for a formal investigation, we have substantial legal review to ensure that all of our recommendations are substantiated so that when we hand them off for further actions for commanders and other organizations, that the information there is

usable, for whatever action they may deem appropriate. All of that has been part of our review.

We conducted, primarily by Major General Fay's efforts, 170 interviews. We looked at more than 9,000 documents and these were all collected and collated using state-of-the-art intelligence tools which allowed us to cross reference information, identify places where there were disconnects, and identify information which required further interviews so that we could fill in those gaps.

The team, as noted there, consisted of numerous personnel who were both subject matter experts and experts in investigations and review. I should point out that General Fay not only is a military intelligence officer but in his civil duties, works in the investigative part of insurance operations. He has brought both those talents as a Reserve officer with him to this effort, as well as the capabilities within our Intelligence Community.

Finally, after the reports were assimilated, we conducted an independent review using DOD, Department of the Army personnel, to look at the information which we had accumulated, specifically to ensure that all of our recommendations were on point and substantiated by the information which we had collected.

I know this is very difficult to see, and I will try to describe this for you in terms of what the picture is meant to say. This is a map of Iraq, a country about the size of Texas and a country that has been beset by the dictatorship of Saddam Hussein, which is no longer present today. The charts show you detention facilities in two different colors: blue and red.

[The chart referred to follows:]

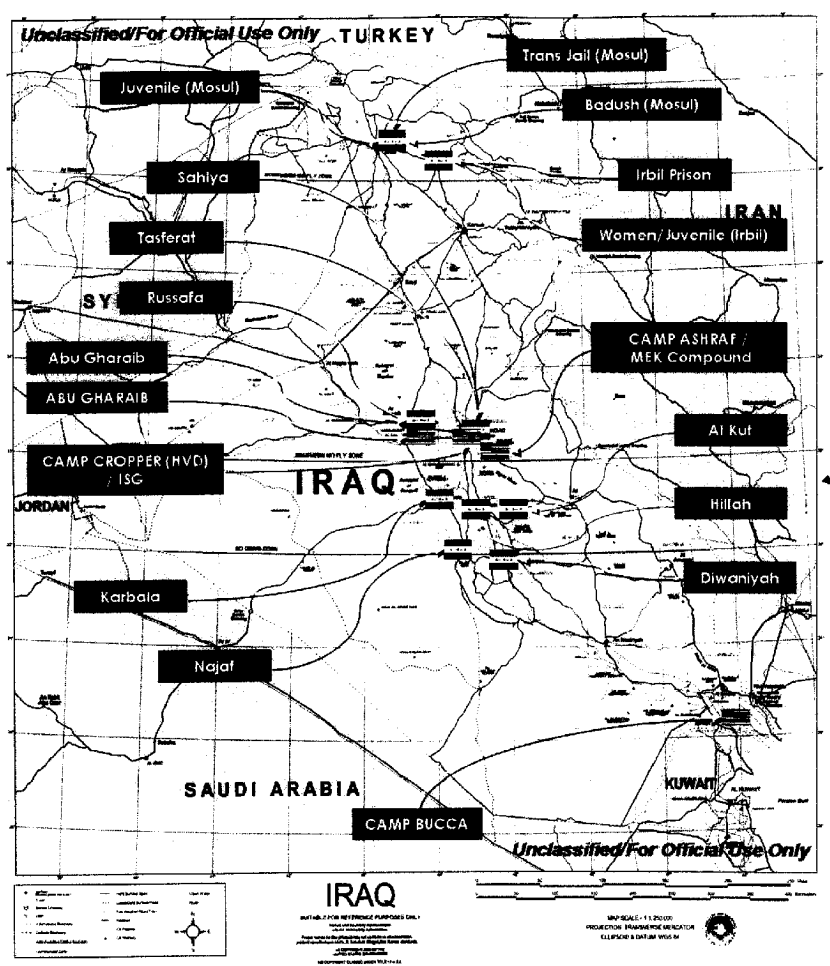

The blue facilities are primarily those facilities which were maintained by the Iraqis. Each of them, however, had U.S. presence as the operation that overthrew the Saddam-Baath regime took on the responsibility as the governor of Iraq. So Lieutenant General Sanchez's role with Ambassador Bremer included oversight of all of those facilities.

The red indicates those which were dedicated to U.S. operations, and you will note that Abu Ghraib is shown in both red and blue on the outskirts of Baghdad. That in itself points to the fact that there were civil detainees held by the Iraqis; murderers, looters, and rapists who were held in that facility. This is a violation of our own regulations and policy that says we should not co-mingle military detainees with civil detainees, but it was a clear decision made by the Coalition Provisional Authority (CPA), that this was the only facility available that we could use. It did contain a facility, which I will talk about in a minute, with a capability to hold about

12,000 detainees, the way it was designed. Lieutenant General Sanchez made the decision that we would also use it for the military detainees. So, it was designed to keep them separate from the civil detainees. But, that in itself, is a problem with the way our own regulations require us to operate.

If I could look specifically at the next chart of Abu Ghraib. This is an overhead photograph of the facility. I think most of you are generally familiar with it, but I think it is important to note a few points.

[The chart referred to follows:]



First, the facility is a detention facility for 12,000 people, but most of it had been destroyed during the previous months of war. It had been destroyed both by attacks but also by a significant amount of looting by the Iraqi citizens after the fall of Baghdad. Much of the facilities, as detention facilities, were not usable.

What is shown in the lower left, as you are looking at the picture, is the tent area where the detainees were housed. This plays a role in the way operations took place because during the summer period, it was hot and most of that tentage had the sides rolled up, so one could see what was occurring inside it. There are very few reports of any abuse or any other irregular activities that took place during that time.

However, it was under mortar attack, and so people were vulnerable to those attacks living in those tents. A decision was made to rebuild and use the hard sites, 1A and 1B. Those facilities provided protection and also where the military intelligence high-value detainees were to be held and interrogations were to be held. It is in these hard-site facilities, which were not visible from the outside

and for which no cameras were present inside to observe, that the majority of the abuses take place. So that has a bearing clearly on the facilities that were used and what happened.

If I could talk about the next point. The expectation, when Lieutenant General Sanchez was given command of CJTF-7, was that we were in a transition period. Specifically, the orders called for moving from a period of hostilities, which were declared ended in May, to a period of stability and support in phase 4 when he took command. General Sanchez entered the theater as a division commander, a Major General, and commanded the 1st Armored Division, and in June he was promoted to Lieutenant General and given command of the U.S. 5th Corps, the corps which had conducted the attack into Baghdad. The corps then was quickly converted to a Combined Joint Task Force, CJTF-7. In the process, as noted in our report, the manning documents took until December to be finally approved for the Combined Joint Task Force as opposed to the U.S. Army's 5th Corps. During this period, we found that the resources of the personnel in the brigade were about 40 percent of the final agreed-to strength, which was not made available at the time and was not agreed upon until December 2003.

There was also an expectation, in stability and support operations, that the number of detainees would decrease, not increase. Our chart here points out to you that during this period of transition, that is not what occurred. In fact, the number of detainees increased over the entire period, and shown in the dark purple at Abu Ghraib they increased consistently during that period, even after they decreased throughout the country as we collapsed detention facilities and eliminated some of them, so that those personnel were brought into Abu Ghraib.

[The chart referred to follows:]

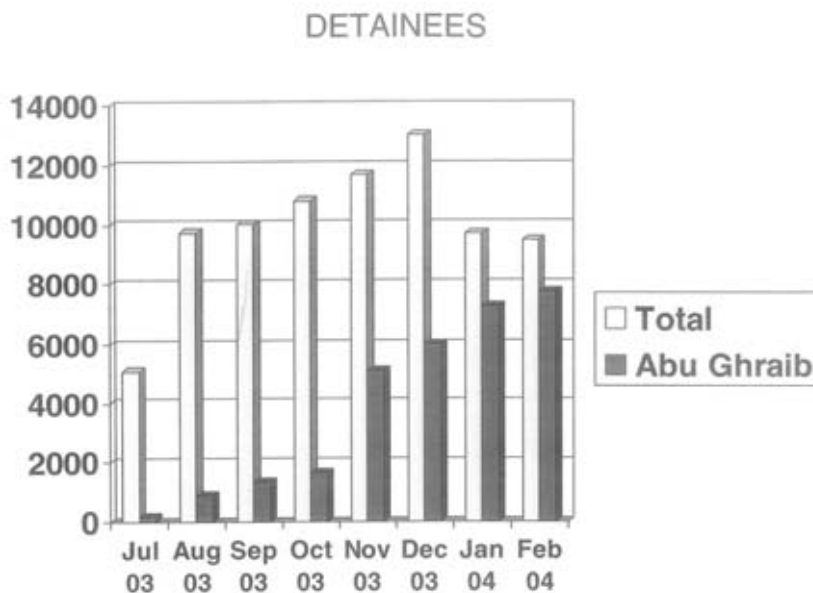

In addition, increased hostilities were taking place during this period and so the number of operations, which were conducted both to collect intelligence and to provide security for our forces, so that the mission of reconstructing Iraq could go on, resulted in increased numbers of detainees. So those numbers continued to increase during the entire period of this transition.

The mission that General Sanchez received with his task force to conduct stability and support operations and to support Ambassador Bremer in the reconstruction of Iraq found that, in fact, he was being attacked during that entire period. This addresses one of the issues which you raised about the pressure from General Sanchez to collect intelligence. He saw his forces and the Iraqi citizens being attacked. As a division commander, he was using information which we call order-of-battle, which defined what the enemy looked like, how their organizations were put together, their personalities, and the types of equipment that they used. He now found himself being attacked with a faceless enemy and it was his job to define that enemy. So collection of intelligence became a critical part of that effort.

In order to accomplish that during this period, he asked for additional help and assessments be brought in by Major General Miller, who was running the detention facilities at that time at Guantanamo and by Brigadier General Fast, who came and did an intelligence assessment of how intelligence fusion was to take place. Brigadier General Fast was assigned to the command as the chief intelligence officer, all with the purpose of fusing intelligence and creating the intelligence picture of who was conducting the attacks and how General Sanchez could prevent further attacks against U.S. forces and Iraqi forces. That is the background and the environment that General Sanchez found himself in, as the operations continued during this period.

If I go specifically to Abu Ghraib, one of the issues that we point out is that while the number of detainees, again shown in the dark purple, was increasing, the number of military intelligence holds, shown in the lighter blue, also was increasing during that entire period to over 1,000, but the delta is also somewhat misleading because a number of those detainees arrived at Abu Ghraib without proper documentation so that the interrogators had to do some sorting to define who was of military intelligence value and who was not. So, the interrogations required much more of a focus than just military intelligence high-value targets; it included a much larger number of personnel.

[The chart referred to follows:]

ABU GHRAIB PRISON

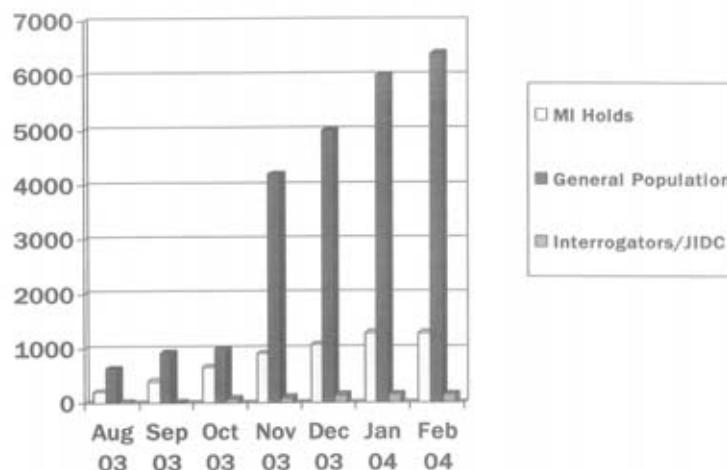

The number of people assigned to do that interrogation at the joint interrogation center, shown in green, was at a low of about 14 when they got started and today numbers over 160, but they clearly did not achieve those numbers during the period of this investigation, and that has a bearing on the number of people he had to conduct those investigations.

Senator Levin, you pointed out a number of the figures which we reported and I would like to summarize these very quickly as to what we did find. It is clear that this was not just an aberration by the military police, that the military intelligence personnel were involved. But it went beyond that as well, as we will point out to you. We show that abuse, which we define very specifically as a violation of international law under the Geneva Conventions, did take place by military intelligence personnel. Numbers get confusing, so I will try to clarify then.

We report 44 cases of abuse, separate incidents of abuse. What I am reporting to you on these charts are the people, the individuals whom we found.

[The chart referred to follows:]

205TH MI BRIGADE PERSONNEL

Alleged to be Involved in Detainee Abuse:

- Abuse:
 - MI Personnel: 23
 - Contractors: 4 Total: 27

- Failure to Report:
 - MI Personnel: 6
 - Contractor: 2 Total: 8

Some of them were involved in more than one incident, and so those two numbers do not correlate; the number of incidents versus the people which we are showing here. But we found that 23 military intelligence personnel were guilty of abuse, and this ranged from relatively simple things because they did not understand, such as interrogating somebody who was naked, which is defined as an abuse of humility in the interpretations of the Geneva Conventions, to very severe abuses such as we reported to you with dogs, which we did find, misinterpreted, and used as part of the interrogation process. We found, of those 44 sets of abuses, that 13 of them involved interrogation, and so those are the personnel that we are reporting to you who fall into both of those categories.

In addition, we found four contractors guilty of abuse. Contractors were used as linguists, as interrogators, and as analysts. The contractors are being reported to the Department of Justice (DOJ) for further recommendations as to how they are to be handled since they do not fall under the Uniform Code of Military Justice (UCMJ). How we handle contracts is an issue which we all need to resolve in the future to ensure that we all abide by the same standards and it is very clear within our contracts what the rules are.

In addition, we found that there was a failure to report by both military intelligence personnel and contractors. We felt that this was significant. It was very clear in our doctrine and our training that people are to report violations of international law and the Geneva Conventions. These were failures of leadership and failures of individuals who walked by abuses and did not report them. In a civilian context, in our view, this would be like a policeman walking past a crime scene and not reporting it or doing something.

Chairman WARNER. Do you have a breakdown of rank in the 23 officers, enlisted and likewise, in the failure to report?

General KERN. We have that in our report, Senator. I do not have it at the tip of my fingers.

Chairman WARNER. It is a mix.

General KERN. It is a mix.

In addition, for non-military intelligence personnel, military police, as was reported previously by Major General Taguba, there are seven who were previously charged. Those are the court cases which you see that are being followed today. In addition, we found three more and we also found one more military police failure to report.

We also found that there were medical personnel who failed to report abuses even though they could clearly see what had happened.

[The chart referred to follows:]

Non-MI Personnel

Alleged to be Involved in Detainee Abuse:

▪ MP:	
▪ Previously Charged:	7
▪ Newly Identified:	
▪ Abuse:	3
▪ Failure to Report:	1
▪ Medical:	
▪ Failure to Report:	2

I would like to summarize our findings in these points.

[The chart referred to follows:]

FINDINGS

- No single cause that resulted in Abu Ghraib abuse.
- The primary causes of the detainee abuse were individual misconduct, a lack of discipline, and leadership failure.
- Vast majority of Soldiers perform their duties appropriately, honorably, and in accordance with law and regulation.
- Ghost Detainees.

First, there is no single cause. There are multiple causes of the abuses that took place at Abu Ghraib.

Second, as you pointed out, Senator, the primary cause of detainee abuse was individual misconduct, but also very disappointing to us is there was a failure of leadership and a failure of discipline, both hallmarks of our soldiers that we expect to be followed. In these cases, we found that there were failures in the en-

tire chain of command and in many cases a lack of a chain of command to oversee the operations that took place. What should have been reported by noncommissioned officers and officers was not.

I really would like to emphasize this point, the vast majority of our soldiers are doing the right thing and are following the right standards. We are reporting to you on those that did not. We are taking action to ensure that those corrections are in place, and I will tell you today that if you visited Abu Ghraib, if you visited with our soldiers, you would see a very different picture. The 7,000 is now fewer than 2,400. The number of boards takes place on a regular basis to review the detainees and to ensure their release is appropriate. 1A and 1B now belong entirely to the Iraqi government, and so when a determination is made that a detainee is no longer to be held in U.S. custody, if they violated an Iraqi law, they are turned over to the Iraqi government for detention and further disposition in their court system. Others are returned to their hometowns, but not just let out the front gate and said go home. They make a strong effort today to go to the town, bring in the community, to talk to the religious leaders, the imams, to talk to the community leaders to ensure that they welcome these people back and know that they have been cleared even if they had been brought into a U.S. detention facility. So we are working both for the quality-of-life for these people and the cultural issues as they are returned to their towns from which they were originally captured.

The soldiers there, are being screened through a certification process to know that they clearly understand the rules of interrogation and detention. The medical personnel are providing medical care today in those facilities far better than most of those people have seen in their entire lives. So all of those previous problems which were reported are greatly improved today, and I would report that it is also underway that we will close out this facility for U.S. operations in the future.

Finally, ghost detainees. This is perhaps one of the more troubling pieces of our investigation. We did find, in fact, that there were detainees brought into Abu Ghraib who were not registered in accordance with our regulations and policy. These personnel in some cases, eight that we could identify, were done under an article 143 exception which says for military security purposes, you do not have to register them immediately. That is part of the Geneva Conventions. It is allowed. But we also found many reports, which we cannot document for you because the documentation does not exist, of people who were brought into the facilities and who were moved so that they could not be identified by the ICRC. This is in violation of our policy which requires us to register people so that it can be reported that they are being held in detention.

We have taken those actions and, as required by the instructions that we have given, asked two organizations to do further investigations, the DOD Inspector General and the CIA Inspector General. Both have agreed that they will take on that task of investigating this ghost detainee policy. The CIA has provided us a document that says their current policy is to abide by our regulations and policies if they bring a detainee to our facilities. But that policy was apparently, from what we can find, either not in effect or not

known at the time that the violations that we believe happened are being reported. That is what we are asking for further investigation to go into.

Chairman WARNER. What is the volume of cases?

General KERN. I cannot give you a precise volume, Mr. Chairman, because there is no documentation of the numbers, but we believe, and I would ask General Fay to perhaps add to this, that the number is in the dozens perhaps up to 100. I cannot give you a precise number.

General FAY. Yes, that is accurate, sir. We were not able to get documentation from the Central Intelligence Agency to answer those types of questions, so we really do not know the volume, but I believe it is probably in the dozens.

Senator LEVIN. Up to 100?

General FAY. I doubt that it is that high, sir, but I think it is somewhere in the area of maybe 2 dozen or so, maybe more.

General KERN. It is a very difficult question for us to answer, Mr. Chairman, because we do not have the documentation. What you see in our report is during the interviews of people reporting to us what happened without documentation.

That is a summary of what we found and the causes of it: failures of leadership, failures of our own discipline when we expect people without leadership to do the right thing, failures to follow our own policy, doctrine, and regulations which allowed these to take place, confusion because other policies which were designed for other theaters, Guantanamo, Afghanistan, found their way into documentation that we found in Abu Ghraib which led to numerous iterations of how interrogations and the limits of authority were to be conducted. Those policies were being debated while we were asking soldiers to conduct interrogations, and so they were seeking to find their limits of authority. At the same time, as reported, they were receiving pressure to produce intelligence. The purpose of interrogations clearly is to produce intelligence, and so that is a natural state of affairs. What was not occurring, though, was the leadership to stand in, in between the interrogators and those who were trying to determine the intelligence, to relieve the pressure on the interrogators. This is again a failure in the leadership and the chain of command to do the right thing. We have found and it is reported in here, that it is not just enlisted soldiers. There are commissioned officers through the grade of colonel whom we believe are culpable and through the grade of general officer whom we believe are responsible for these allegations and for the actions that took place.

Mr. Chairman, that summarizes our findings for you and we are ready for your questions.

[The prepared statement of General Kern follows:]

PREPARED STATEMENT BY GEN PAUL KERN, USA

Mr. Chairman, Senator Levin, and members of the committee, on behalf of Lieutenant General Jones, Major General Fay, and Major General Taguba, I appreciate the opportunity to appear before you today and report to you the findings of our investigations concerning the events surrounding the allegations of detainee abuse at Abu Ghraib.

I am General Paul Kern, the Commander of the United States Army Materiel Command at Fort Belvoir, Virginia. On June 16 of this year, acting at the direction of the Secretary of the Defense, the acting Secretary of the Army designated me as

the new appointing authority for the investigation that Lieutenant General Sanchez began back on March 31, 2004. This investigation, or “Procedure 15” specific purpose was to look into the alleged misconduct by certain personnel assigned or attached to the 205th Military Intelligence Brigade at Abu Ghraib Detention Facility. As you know from prior hearings, Major General Taguba’s investigation focused on the 800th Military Police Brigade. I have spent 41 years wearing an Army uniform, and was taught to live by standards—duty, honor, country, the Code of Conduct, the Army values, the Soldiers’ Creed.

Over the years of my career, I have been led by and inspired by incredibly talented and dedicated individuals—soldiers like SPC Patrick Miller, an Ordnance Soldier who fought bravely and courageously until he was captured in An Nasiriya—to senior officers such as Generals McArthur and Patton. These people, and thousands like them, dedicate their lives to their country quietly, with honor.

Our report, however, discusses the failure of a relatively small number of soldiers who served at Abu Ghraib prison. The teams conducted an investigation that focused on the 205th Military Intelligence Brigade and its chain of command; however, we went where the facts led us. Our final report from this investigation is complete. In the course of this investigation, we discovered serious misconduct and a loss of moral values. We set our course to find truth, not to “whitewash” nor to convict those who are not incriminated. We found the pictures you have seen were not the result of any doctrine, training or policy, but violations of law.

We learned there were leaders in Abu Ghraib who knew about this misconduct—knew better and did nothing. Some soldiers behaved improperly because they were confused by their experiences and direction. We violated our own regulations by allowing “ghost detainees” in detention facilities.

All this was happening as thousands of soldiers, sailors, airmen, marines, civilians, and contractors fought bravely to restore an elected government in Iraq and Afghanistan. We are very proud of their service, commitment, courage, and values. They and their families can stand tall and proud. I regret, however, that we must report on those who failed.

Our investigation team brings a depth of knowledge and experience necessary to the task of investigating the activities regarding alleged detainee abuse at Abu Ghraib.

Lieutenant General Jones has over 34 years military service, commanding at all levels up through major general. He is currently the deputy commander of one of our Army major commands. He has served in the operational Army, both conventional and special operations, leading soldiers in war, contingency operations, and in peace. He is a great trainer, and was the commander of Fort Rucker, AL, where he was charged with initial military training, doctrine, leader development and creating the vision for the future. He has served in assignments overseas including duties in Europe, Korea, Bosnia, and Southwest Asia. His experience also includes being the chief of staff for the 24th Infantry Division and the U.S. Army Europe. His depth and breadth of operational assignments, experience at the tactical through strategic levels, and knowledge of training and doctrine have been invaluable to the scope of our investigation. He is a soldier’s soldier who knows what is right.

Major General Fay served on active duty for 4 years, followed by 27 years in the Army Reserve. He was mobilized immediately after September 11 and has been on active duty for almost 2½ years since then. The vast majority of both his active and Reserve experience has been in Military Intelligence. In civilian life, Major General Fay is a managing director of a major global property/casualty insurance company. He has nearly 30 years’ experience investigating and overseeing complex claims and litigation.

The investigative teams conducted a comprehensive review of all available background documents and statements pertaining to Abu Ghraib from a wide variety of sources. These sources included the reports written by MG Geoffrey Miller, MG Donald Ryder, MG Antonio Taguba, and the Department of Army Inspector General. Lieutenant General Jones did extensive review of previous reports, operations plans, policy memorandums, and sworn statements collected by the Major General Fay team. He also personally interviewed LTG Richardo Sanchez and MG Barbara Fast, the CJTF-7 Senior Intelligence Staff Officer. Major General Fay’s team conducted over 170 interviews concerning the interviewees’ knowledge of interrogation and detention operations at Abu Ghraib and/or their knowledge of and involvement in detainee abuse. Major General Fay’s interviews included interviews with Major General Fast, MG Walter Wojdakowski, MG Geoffrey Miller, MG Thomas Miller, and BG Janis Karpinski. Over 9,000 documents were collected, catalogued, and archived into a database. My review team consisted of 12 people, including general officers, subject matter experts and legal advisors. The investigative teams traveled

to Iraq eight times, including a visit by the appointing authority and investigating officers in early August 2004.

The events at Abu Ghraib cannot be understood in a vacuum. Three interrelated aspects of the operational environment played important roles in the abuses that occurred at Abu Ghraib. First, from the time V Corps transitioned to become Combined Joint Task Force-7 (CJTF-7), and throughout the period under investigation, it was not resourced adequately to accomplish the missions of the Combined Joint Task Force. Those missions were stability and support operations (SASO) and support to the Coalition Provisional Authority (CPA). The CJTF-7 headquarters lacked adequate personnel and equipment. In addition, the military police and military intelligence units at Abu Ghraib were severely under-resourced. Second, providing support to the CPA required greater resources than envisioned in operational plans. Third, operational plans envisioned that CJTF-7 would execute SASO and provide support to the CPA in a relatively nonhostile environment. In fact, opposition was robust and hostilities continued throughout the period under investigation. Therefore, CJTF-7 had to conduct tactical counterinsurgency operations, while also executing its planned missions. That is the operational context in which the abuses at Abu Ghraib took place.

ABUSES

We found that abuses—on the part of military intelligence and military police personnel—clearly occurred at the prison at Abu Ghraib. For purposes of this report, abuse is defined as treatment of detainees that violated U.S. criminal law or international law or treatment that was inhumane or coercive without lawful justification. Whether the soldier or contractor knew, at the time of the acts, that the conduct violated any law or standard, is not an element of the definition.

There is no single, simple explanation for why this abuse at Abu Ghraib happened. The primary causes are misconduct (ranging from inhumane to sadistic) by a relatively small group of soldiers and civilians, a lack of discipline on the part of the leaders and soldiers of the 205th MI BDE and a failure or lack of leadership by multiple echelons within CJTF-7. Contributing factors can be traced to issues affecting command and control, doctrine, training, and the experience of the soldiers we asked to perform this vital mission.

The abuses at Abu Ghraib primarily fall into two categories: a) intentionally violent or sexual abuse and, b) abusive actions taken based on misinterpretations or confusion regarding law or policy.

Lieutenant General Jones found that while senior level officers did not commit the abuses at Abu Ghraib, they did bear responsibility for lack of oversight of the facility, failing to respond in a timely manner to the indications and warnings provided by reports of incidents within the command and as reported by agencies such as reports from the International Committee of the Red Cross (ICRC), and for issuing policy memos that failed to provide clear, consistent guidance for execution at the tactical level.

Major General Fay found that from 25 July 2003 to 6 February 2004, 27 205th MI BDE Personnel allegedly requested, encouraged, condoned, or solicited Military Police (MP) personnel to abuse detainees and/or participated in detainee abuse and/or violated established interrogation procedures and applicable laws and regulations during interrogation operations at Abu Ghraib.

Most, though not all, of the violent or sexual abuses occurred separately from scheduled interrogations and did not focus on persons held for intelligence purposes. No policy, directive or doctrine directly or indirectly caused violent or sexual abuse. In these cases, soldiers knew they were violating the approved techniques and procedures.

Confusion about what interrogation techniques were authorized resulted from the proliferation of guidance and information from other theaters of operation; individual interrogator experiences in other theaters; and, the failure to distinguish between interrogation operations in other theaters and Iraq. This confusion contributed to the occurrence of some of the nonviolent and nonsexual abuses but did not contribute to the abuse that you have seen in the photographs.

Alleged incidents of abuse by military personnel have been referred to the CID for criminal investigation and the chain of command for disciplinary action. Alleged incidents of abuse by civilian contractors have been referred through the Department of Defense (DOD) to the Department of Justice (DOJ).

DISCIPLINE AND LEADERSHIP

Military Intelligence and Military Police units had missions throughout the Iraqi Theater of Operations (ITO); however, 205th MI Brigade and 800th Military Police

Brigade leaders at Abu Ghraib failed to execute their assigned responsibilities. The leaders from units located at Abu Ghraib or with supervision over soldiers and units at Abu Ghraib, failed to supervise subordinates or provide direct oversight of this important mission. These leaders failed to properly discipline their soldiers. These leaders failed to learn from prior mistakes and failed to provide continued mission-specific training. The 205th MI Brigade commander did not assign a specific subordinate unit to be responsible for interrogations at Abu Ghraib and did not ensure that a Military Intelligence chain of command at Abu Ghraib was established. The absence of effective leadership was a factor in not sooner discovering and taking actions to prevent both the violent/sexual abuse incidents and the misinterpretation/confusion incidents.

Neither Department of Defense nor Army doctrine caused any abuses. Abuses would not have occurred had doctrine been followed and mission training conducted. Nonetheless, certain facets of interrogation and detention operations doctrine need to be updated, refined or expanded, including, the concept, organization, and operations of a Joint Interrogation and Debriefing Center (JIDC); guidance for interrogation techniques at both tactical and strategic levels; the roles, responsibilities and relationships between Military Police and Military Intelligence personnel at detention facilities; and, the establishment and organization of a Joint Task Force structure and, in particular, its intelligence architecture.

OTHER CONTRIBUTING FACTORS

Demands on the Human Intelligence (HUMINT) capabilities in a counter-insurgency and in the future joint operational environment will continue to tax tactical and strategic assets. The Army needs trained and experienced tactical HUMINT personnel.

Working alongside non-DOD organizations/agencies in detention facilities proved complex and demanding. The perception that non-DOD agencies had different rules regarding interrogation and detention operations was evident. Interrogation and detention policies and limits of authority should apply equally to all agencies in the Iraqi Theater of Operations.

"GHOST DETAINEES"

My investigation resulted in specific findings regarding the issue of "ghost detainees" within Abu Ghraib. It is clear that the interrogation practices of other government agencies led to a loss of accountability at Abu Ghraib. DOD must document and enforce adherence by other government agencies with established DOD practices and procedures while conducting detainee interrogation operations at DOD facilities. This matter requires further investigation and, in accordance with the provisions of AR 381-10, Part 15, is being referred to the DOD Inspector General, as the DOD liaison with other government agencies for appropriate investigation and evaluation.

Soldiers/sailors/airmen/marines should never be put in a position that potentially puts them at risk for non-compliance with the Geneva Conventions or Laws of Land Warfare.

CONCLUSION

Leaders and soldiers throughout Operation Iraqi Freedom were confronted with a complex and dangerous operational environment. Although a clear breakdown in discipline and leadership, the events at Abu Ghraib should not blind us from the noble conduct of the vast majority of our soldiers. We are a values based profession in which the clear majority of our soldiers and leaders take great pride.

A clear vote of confidence should be extended to the leaders and soldiers who continue to perform extraordinarily in supporting our Nation's wartime mission. Many of our soldiers have paid the ultimate sacrifice to preserve the freedoms and liberties that America and our Army represent throughout the world. The events of this report stand in stark contrast to the values and honor of all these Americans. With that, we look forward to answering your questions.

Chairman WARNER. Did you specify in your report the names of those individuals?

General KERN. Sir, we did.

Chairman WARNER. Thank you.

General KERN. They have all been referred to their chain of command for proper disposition.

Chairman WARNER. General Jones, do you have anything that you would like to say?

General JONES. No, sir.

Chairman WARNER. Would any other member of the panel like to have the option to have an opening statement?

General Whitcomb: No, sir.

General FAY. No, sir.

Chairman WARNER. If not, we will proceed to the questions then. Thank you very much.

First, General Kern, I have had the privilege of knowing you for a very long time and I commend you and your colleagues for a very professional job.

Do you have a personal opinion, and we have always said when you achieve the rank of four stars you have the privilege of expressing your personal opinion when you come before this committee, as to whether or not there remains to be other areas in this overall investigation that have to be pursued?

General KERN. As we have stated in our report, clearly the issue of the ghost detainees, which pertains to the question that was asked by Senator Levin, how did these other documents find their way into it, were there other sets of rules for other agencies, needs to be further investigated.

I believe that part of the answer, personally, is that we are in the information age and the information that we found on computers that were located in the prison virtually came from everywhere. So the worldwide web works, and information which was being debated back here in the United States found its way into the hard drives of the computers that we found in the prison. So that is part of today's world that we have to learn how to deal with, in this flow of information.

My personal view is that we ought not to make a soldier and in this case also contractors, a determination of what their limits of authority are while the debates are going on. We need to be crisp and clear in our delivery of orders to these people so that they know what the rules are.

Chairman WARNER. Have you reached any conclusions about the current viability of the system to collect intelligence desperately needed at the tactical level? Has that collection procedure been degraded in any way by the seriousness of this problem and consequently the reluctance of others maybe to go to the limit of regulations for fear of reprisal as they conduct their ongoing operations of intelligence?

General KERN. Mr. Chairman, I think the answer is in two parts. First, the intelligence fusion today is significantly better than it was in June when the CJTF-7 was established. That is a result of work that was done by General Fast in bringing in these collection efforts and integrating both the intelligence efforts of the outside agencies, outside of the DOD, with our efforts, providing the information and interrogations so that those informations are cross referenced against other interrogations which are ongoing. The inclusion of the BAT system, a biometric system, of identifying individuals so that we can identify specifically who the person is and make sure that it could be cross referenced against FBI files or any other system. So, the intelligence collection/infusion process is con-

siderably better today than it was early on in the process by the work of the folks who are in this theater.

But I would also report to you that we have very serious concerns that there are going to be people who are holding back because of all of the allegations currently underway. I cannot document for you the fact that that is happening, but that is a clear concern that we need this intelligence right now, to make sure that we can prosecute military operations to their fullest capability and that is a concern.

Chairman WARNER. Then that would shift, General Fay, to your position, together with the chief of intelligence in the United States Army. Are you addressing that issue now?

General FAY. Yes, sir, indeed, we are. In fact, we did see a significant drop-off in intelligence reports that resulted from interrogations in Iraq when all of these things started to come to light. We believe we have effectively addressed that already. The numbers have risen back up to approximately the same number they were before these abuses came to light, and I think we are doing a very effective job of educating soldiers with the tools they have. Those approved techniques within the Field Manual (FM) can be used very effectively without resorting to other harsher techniques and still obtain the intelligence that we need.

Chairman WARNER. Have you promulgated instructions along the line to the current MI folks down in the trenches?

General FAY. There has been a significant amount of ongoing retraining and refocusing and a lot of instructive material being provided and teams being provided to update and bring them back up to the soldiers. As General Kern said, there is a recertification process that is currently going on in all of our facilities to make sure that every single one of the soldiers and contractors, that are doing the interrogations today, are certified before they are allowed to go into the interrogation booth.

Chairman WARNER. General Whitcomb, you are the user. How do you feel about the current situation?

General WHITCOMB. Mr. Chairman, that soldiers, initially I would agree primarily, at the point of capture, were a little more reticent to try to get into any information intelligence gathering. As General Kern and General Fay both pointed out, the current system has been vastly improved upon. I do not see reluctance on the part of interrogators, at this point, to conduct interrogations. The quality of intelligence that is being provided, perhaps because we have better focused what we are asking for, has resulted in better intelligence and more usable information for our folks.

Chairman WARNER. The checks and balances are in place such that, in your professional judgment, this type of situation would not happen again?

General WHITCOMB. Absolutely, Chairman.

Chairman WARNER. Lastly, to General Taguba, General, for a while you were a lone voice, and I think the extraordinary professionalism, conviction, and determination that you manifested gave an inspiration to those who followed. Again, I commend you for your job.

But I would ask, it has been over 5 months since you completed your report and forwarded your recommendations for action, in-

cluding to conduct an investigation of the 205th MI Brigade. In the intervening months, several more investigations have been completed. What was your recommendation concerning General Karpinski and what action was subsequently taken by the chain of command and did it meet your satisfaction?

General TAGUBA. Sir, first of all, thank you for your kind comments.

With regard to your question, the recommendation that we provided to our chain of command, in this case to the appointing authority and General McKiernan, was to relieve her for cause, sir, and other administrative actions. As far as I know, she is still under suspension from command, and I was informed that there were subsequent other investigations that are being meted out with regard to her status.

Chairman WARNER. Your judgment with regard to Colonel Pappas?

General TAGUBA. Sir, the same. We stood by our recommendation. But that was all predicated on the recommendation that we made to Generals McKiernan and Sanchez at the time that based on the credible information that we received that a Procedure 15 be initiated. Subsequently, of course, their findings would provide other recommendations in regards to his actions.

Chairman WARNER. Thank you very much. My time is up.
Senator Levin.

Senator LEVIN. Thank you, Mr. Chairman. Let me add my thanks for the testimony. It was very helpful.

Has there been a direct request to the CIA for the information which so far has not been forthcoming?

General KERN. I will answer that in two parts. First, General Fay had made earlier requests for documentation. That has not been provided. Second, the CIA, both their Inspector General and their General Counsel, have met with myself and our committee and have agreed to pursue that investigation.

Senator LEVIN. Mr. Chairman, that is totally unacceptable that the documents requested from the CIA have not been forthcoming either to General Kern and his colleagues or, in effect, to this committee and to the American people. I would urge that this committee weigh in on that issue.

Chairman WARNER. Yes. Both of us serve on that committee, and I have been in consultation with Chairman Roberts on that because in many ways we have dual jurisdiction. But we will continue to pursue that.

Senator LEVIN. I think there should be a direct request here. This is totally unacceptable.

General Jones, you have said that the military police and military intelligence units at Abu Ghraib were severely under-resourced. I am wondering what was the cause of the failure to adequately resource both the Combined Joint Task Force and the units at Abu Ghraib, because in your report, you have talked about the severe under-resourcing at both?

General JONES. I think it goes back to the genesis of the cessation of hostilities and movement into the next phase of the campaign and the lack of cessation of hostilities, which caused them to not only take on the new missions but continue to fight the war.

In addition, the understaffing of Mr. Bremer's staff in the CPA caused General Sanchez to split his staff to successfully prosecute the insurgency fight, continue the operations to support the CPA, and execute all his missions.

A joint manning document was slowly created. Initially they saw they needed additional staff. They needed intelligence personnel. They needed equipment. They also needed people to establish the joint interrogation and debriefing center. As the skills identified that they needed to execute their mission up through the CENTCOM came up to the Joint Staff, that process to either mobilize the right skills and/or to task the services for people was extremely slow.

Senator LEVIN. Now, you also said that the operational plans envision that CJTF-7 would execute stability and support operations in a relatively non-hostile environment. In fact, opposition was robust and hostilities continued. Was that part of the problem?

General JONES. Yes, sir, it was because they had to continue to prosecute the fight.

Senator LEVIN. So, the failure to have adequate people there was based in part, was it then, on the fact that there was in the planning the belief that there would be a relatively non-hostile environment?

General JONES. Yes, sir.

Senator LEVIN. Who was responsible for that planning?

General JONES. That plan originated early on because that was a phased campaign plan that came out of the CENTCOM. The phase 4, which they transitioned to create the CJTF-7 headquarters, took 5th Corps and their staff of approximately 495 people and transitioned the responsibilities to what was the combined forces land component commander to the CJTF-7. So the magnitude of task was in the plan originally, but it had not perceived that hostilities would continue.

Senator LEVIN. Now, the Schlesinger panel suggests that CJTF-7 was reluctant to submit a request for forces for additional units because CENTCOM had refused to forward a previous request for additional personnel to the Joint Staff and that that, in turn, created an understanding among military commanders that requests for additional forces would not be favorably considered and that they were to make do with the forces that were currently available. Do you concur with the Schlesinger panel on that?

General KERN. I would comment and then let General Jones.

Two issues. First, the original phase 4 order called for return of forces, and so that was part of the direction given to the CJTF-7 at the time. I think General Abizaid quickly realized and put a stop to the return of forces when he took over as commander and recognized the need of a new headquarters to be established, which is the case today with General Casey in the theater. But that took, as described, a long time for that to happen.

General Jones?

General JONES. Sir, in the plan, one of the assumptions was that with the cessation of hostilities, we would have more support from our allies and other coalition forces, which would offset the need for additional forces.

The second part of that, I would say the primary concern of General Sanchez and his staff was getting the operational intelligence architecture in place to try to find out who the insurgents were, what was their chain of command, and what was their support base. This was done to fuse the intelligence efforts with all the agencies in theater and to get more of an operational and strategic focus based on the missions they assumed.

Senator LEVIN. In terms of my question, though, the Schlesinger report's suggestion, that there was an understanding among the commanders that request for additional forces would not be favorably considered, based upon a rejection of a previous request, and that they should make do with the forces that they had, do you concur with the Schlesinger panel?

General JONES. Sir, I cannot comment on that because I did not see that.

General WHITCOMB. Sir, perhaps I could comment from a CENTCOM perspective. We worked very closely with CJTF-7, of course, on their manning requirements. I know of no request for forces that was submitted by any of our subordinate units that we did not take action with and work with the Joint Staff and the Services to resource.

Senator LEVIN. There was not a request, but General, my question was, was there an understanding that requests would be favorably considered?

General WHITCOMB. Sir, I cannot comment on an understanding by anyone on the CJTF-7 staff that a request would not be favorably considered by CENTCOM. What I can address is that, from a CENTCOM perspective, every request for forces was actioned, and I know of no request for forces that we turned down.

General KERN. Senator Levin, I think you see two things that happened here. First, the original order for phase 4 had return forces, and so you have an order that says, "do not ask for more return forces." General Abizaid realized very quickly and stopped that. So he modified that period. So I think there was a period in which one could assume that that was what you were directed to do, but the reality very quickly set in that we were going to have to go the other direction and that happened.

Senator LEVIN. My time is up. Thank you.

Chairman WARNER. Senator McCain.

Senator MCCAIN. Thank you. I want to thank the witnesses.

Mr. Chairman, I would like included in the record an article in this morning's Wall Street Journal by Jim Schlesinger that I think puts this situation that we are facing in a good perspective. The last paragraph of his article says: "Our panel's report recorded both errors of commission and of omission, but we found no indication of a policy encouraging abuse. The abuses that did occur and the failed oversight that allowed them are an embarrassment. They do not reflect the standards that America sets for itself. We must take the steps necessary to see that these standards are upheld in the future. These actions by historical standards are quite limited in number and not representative of the overall behavior of our forces which has been generally admirable."

Chairman WARNER. Without objection.

[The article of Dr. Schlesinger follows:]

THE WALL STREET JOURNAL.
The Truth About Our Soldiers

James Schlesinger. Wall Street Journal. (Eastern edition). New York, N.Y.: Sep 9, 2004. pg. A.16

Copyright (c) 2004, Dow Jones & Company Inc. Reproduced with permission of copyright owner. Further reproduction or distribution is prohibited without permission.

When sitting for his portrait, Oliver Cromwell ordered his portraitist, who wanted to pretty Cromwell up, to paint him "warts and all." The independent panel on prisoner abuse in Iraq and elsewhere was bound, also, to concentrate on the warts. Yet Americans must remain aware of the full portrait of our men and women in uniform, a portrait which is more -- much more -- than the warts of Abu Ghraib.

We must bear in mind, continuously, that the overall performance of our armed forces has been commendable. We

must not lose sight of that heartening reality. This reflects two elements: superior technology and trained, professional soldiers. Through the advance of technology, we have been able to target enemy forces with precision. As a consequence, we sought in Iraq to preserve the infrastructure -- so that it could serve that country's future -- and to limit collateral damage. We achieved both aims.

The vast majority of our force has behaved in Iraq with extraordinary forbearance -- including countless acts of kindness. In this respect, its performance has been vastly better than in World War II, Korea and Vietnam. While we did not spell this out in the panel's report, I can only say -- in light of some of the public commentary -- that it deserves emphasis and repetition. OUR TROOPS HAVE PERFORMED WELL.

Bear in mind that we have had some 50,000 detainees -- and that more than 300,000 of our troops have served in Iraq. To be sure, one instance of abuse is one too many. But to date, we have identified some 300 cases of possible abuse of which fewer than 100 have been confirmed; and a third of those have been at the point of capture. In combat, passions run high.

Donald Rumsfeld established our panel to provide an independent and objective assessment of what went wrong in U.S. detention operations in Abu Ghraib and elsewhere: to review the other DoD investigations that were underway for gaps; and to provide any recommendations and additional observations that were required. He added in his charge to us: "Let the chips fall where they may." We have striven to fulfill that mandate. In that effort, we received the full cooperation of the Department of Defense, which is already moving ahead with reforms to prevent a recurrence.

We believe that we have provided a full and accurate description regarding the extent of these abuses and how they came about -- and what might be done in the future to reduce the risk of their happening again. Still, in a matter of this sort, it is important that we not overlook the forest for the trees.

Our prime concern has appropriately been the morale, health and performance of our armed forces -- and to ensure that their behavior upholds the standards that American society believes appropriate. If there are any defects, they must be diagnosed and any infected areas must be lanced and cauterized. In this manner, we can cleanse any stain on the reputation of our armed forces, so that their role continues to be understood and valued by the civilian society.

The administration may have erred, initially, in characterizing the actions at Abu Ghraib as the result of a handful of MPs. Still, in the overall performance, 66 cases of confirmed abuse is a small number. War remains a brutal business, and some critics -- who prefer to believe that it is a stroll in the park -- reveal that they understand neither war nor history. We must not confuse the speed and volume of today's "prime time" news of the abuse with the actual extent of abuse. Once again, comparisons with wars past are instructive.

Our panel found no policy that encouraged or justified abuse -- and more than a few actions taken to avoid abuse. Naturally, given the initial act of terrorism on 9/11 and the spurt in U.S. casualties in the summer of 2003, it was concluded that interrogation should be thorough and aggressive. In the war on terrorism, wouldn't we be naive to limit ourselves to "name, rank, and serial number"? In the conditions of today, aggressive interrogation would seem essential; but the injunction from above was to ensure "humane treatment" of detainees, even those who were judged outside the scope of the Geneva Conventions. Admittedly, "humane treatment" is a subjective concept. Some, including some in the Services, argued that aggressive interrogation went too far. That remains a matter of judgment. It also remains a far cry from a policy that encourages abuse.

The public and international reactions to Abu Ghraib have been exacerbated by the photos taken there. Those photos constitute, to say the least, an idiosyncratic -- and obviously unauthorized -- activity by the night shift on Tier 1.

President Kennedy said during the Cuban Missile Crisis that a picture is worth a thousand words. It clearly is -- if, and only if, you know what the picture means. But if pictures are misinterpreted, they can readily become a mechanism that creates an inaccurate impression. "Nothing can be so deceiving as a photograph," Franz Kafka observed -- with the photos in this case hiding, indeed distorting, the overall performance of our armed forces in Iraq.

The photographs taken at Abu Ghraib are quite misleading. In contrast to the inferences that some initially drew, those photographs had nothing to do with interrogation policy. Not one of the detainees abused in the photograph was a target of interrogation to gain intelligence.

Nonetheless, abuses did occur at Abu Ghraib (and elsewhere) during interrogation. In such cases, the MPs had been encouraged by Military Intelligence personnel to use aggressive tactics. Those excesses must be identified and corrected -- to discourage any copycat behavior in the future. Such excesses may have resulted from confusion as to what was permissible. Some of that confusion may be understandable, since we had interrogator operations in three different places with varying rules. That created ambiguity. Nonetheless, in the future such ambiguity is unacceptable. A policy doctrine should be designed, so that soldiers are trained to observe the rules.

Though abuses were indeed more widespread than observed on the night shift at Abu Ghraib, it is correct to characterize the situation on that shift as having its unique aspects. Some have seized upon the photos to suggest that torture was condoned. That is simply wrong. The actions of the night shift on Tier 1 were an aberration. The members were off on their own. As one participant admitted: "We did it for the fun of it."

Our panel's report recorded both errors of commission and of omission, but we found no indication of a policy encouraging abuse. The abuses that did occur, and the failed oversight that allowed them, are an embarrassment. They do not reflect the standards that America sets for itself. We must take the steps necessary to see that those standards are upheld in the future. These actions, by historical standards quite limited in number, are not representative of the overall behavior of our forces, which has been generally admirable.

Mr. Schlesinger, former secretary of defense, headed the recent Independent Panel to Review Department of Defense Detention Operations.

Senator MCCAIN. Thank you.

General Kern or General Fay, the situation with the CIA and those soldiers is beginning to look like a bad movie. What happens when you ask the CIA? You get no answer? They say we do not have to answer? I mean, what is it? Is it dropping a stone down a well? What happens here in the interface?

General KERN. Let me answer that in two parts, Senator. First, when General Fay asked, it was he who was not allowed to have the documentation which was requested.

Senator MCCAIN. They said he was not allowed to have it?

General KERN. I will ask him to specifically comment on that. But that did change later when I was brought into this in June, and the Central Intelligence Agency, both their Inspector General and General Counsel met with me personally and said we will cooperate in the investigation, but they have not provided it.

Senator MCCAIN. Why does it require an investigation when you ask for documents?

General KERN. I do not have a good answer for you, Senator.

Senator MCCAIN. I think you should say I am not satisfied with an investigation. I want the information.

In addition to that, were their CIA operatives in there just moving around themselves? Did it not require the active participation of the MI people or other Army people?

General KERN. I will let General Fay put some detail on this, but specifically we do report that there was verbal communications that said, "cooperate with the agency."

Senator MCCAIN. That came from?

General KERN. That came from the Combined Joint Task Force intelligence headquarters.

Senator MCCAIN. Headed by?

General KERN. General Fast and Colonel Bolts.

Senator MCCAIN. That said to cooperate with the CIA and carry out their instructions?

General KERN. No. I believe from what we found there were two facts to this. One is intelligence comes from multiple sources and you have to bring it together to be effective. The agency, not just the CIA but other agencies as well, provide that information and that is part of the cooperation that was directed.

Specifically, General Fast was asked, could the agency bring detainees to Abu Ghraib, and she said yes. Her expectations, though, were that the agency would abide by our rules in our facilities, not create another set.

Senator MCCAIN. But somehow that did not happen?

General KERN. That is correct, Senator.

Senator MCCAIN. What do we know about that?

General KERN. We know for a fact that there were people who were brought in who were not recorded.

Senator MCCAIN. We know that somehow the personnel manning the prison, the Army personnel, were told or believed that they should act under the instructions of the CIA to move prisoners around. I think General Fay said dozens so that they would not be made known to the ICRC.

General KERN. That is clearly what we report, that the MI Brigade commander allowed that to happen within his facilities, and we have reported both he and the commander of the joint interrogation and debriefing center, should be held accountable for what their actions were.

I would ask General Fay if he might want to comment.

Senator MCCAIN. Go ahead, General Fay.

General FAY. Sir, if I can just get back to the original question, which was how the requests were made of the CIA. Originally when I was in Iraq, I made the request to CIA Chief of Station through General Fast. She received no response, and I followed up a number of times and still received no response.

Then, when I came back to the United States and continued my investigation here, still getting no response from CIA after making additional inquiries, I eventually made an appointment with the Inspector General of the CIA. I met with the Inspector General and went over my requirements and why I needed the information, and at that point I was informed that CIA was doing its own investigation.

Senator MCCAIN. Investigation?

General FAY. Yes, sir. They said they would not provide me the information that I requested.

Senator MCCAIN. How did you find that this happened that the Army personnel manning the prison carried out the instructions of the CIA? Were the CIA people physically there in the prison?

General FAY. Yes, sir. They would come and bring their detainees to the prison and they would turn the detainees over to the folks at the prison, the military intelligence and military police personnel, in the hard site, in the 1A area. They would be detained there by Army personnel.

Senator MCCAIN. They would be moved around by Army personnel?

General FAY. They would be moved around by Army personnel occasionally, sir, but it was not always being moved around. As an example, on the first ICRC visit that everyone is most familiar

with, the one where they found the naked detainees, the CIA ghost detainees were in their cells at that point in time and on the cells were signs that said OGA 1, OGA 2, OGA 3. There was no attempt at that point to hide those detainees. We believe at other points in time, though, that some of those detainees may have been moved.

Senator MCCAIN. I think that this is something that needs to be asked, Mr. Chairman, of the incoming director of the CIA. This needs to be cleared up rather badly.

Mr. Chairman, I have one quick question. General Fay, did Colonel Pappas retract his sworn testimony to General Taguba in his interview with you that he had approval by General Sanchez and General Miller to use dogs during interrogation with detainees?

General FAY. Colonel Pappas believed that he had the authority to use dogs. He thought he had the authority.

Senator MCCAIN. I think he told General Taguba that he had authority, not that he believed it, but that he had authority. Is that not true, General Taguba?

General TAGUBA. Yes, sir. He made that comment.

General FAY. Yes.

Senator MCCAIN. There is a difference, believing and having.

General FAY. Yes, sir. I believe that he thought that he had such authority. I do not believe he was given such authority. I know he was not given such authority by General Sanchez.

I think there was a miscommunication between Colonel Pappas and General Miller as regards to the conversation with dogs. General Miller did have a conversation with Colonel Pappas, but he was suggesting the use of dogs for security purposes, just as they used them in Guantanamo Bay. They do not use dogs in Guantanamo Bay during the interrogation process and never did. I think it was miscommunicated on the part of Colonel Pappas and he misunderstood that conversation to interpret it to mean that he could use it in the interrogation booth.

Senator MCCAIN. Do you have a comment on that, General Taguba?

General TAGUBA. Sir, with regards to his authority line, the interrogation rules of engagement did indicate that he had to make a request for the use of dogs. That was all in the discussions that was made prior to the publication of the interrogation rules of engagement. I think that was dated October 12.

General KERN. I think, Senator, there are two additional points. First, there is a confusing memo that the CJTF-7 published, where in their final memo it leaves in question the part about the dogs because it says that the dogs should be muzzled if they are there, and so it is left to the interpretation of where "there" is. It was clear, though, that they were not intended to be used in interrogation, though that is what Colonel Pappas believed he was allowed to do.

The second point is that the dog teams actually did not show up until late November, and so most of the abuses had already taken place.

General FAY. That lack of clarity and confusion in all of those memos and those directives that went back and forth is covered in detail in our report as to how that confusion occurred.

Senator MCCAIN. Thank you very much, Mr. Chairman. I thank the witnesses. I thank you for your outstanding service.

Chairman WARNER. Senator McCain, your comments with regard to the Committee of the Armed Services and its responsibility towards this ghost detainee issue are taken under advisement by Senator Levin and myself. We intend to probe and may well have our own independent hearing on this important subject.

Before leaving it, though, one question. Did your report reflect observations of military personnel as to how CIA personnel conducted the interrogation of ghost detainees?

General FAY. No. There were no Army personnel present during the interrogations that were being done by CIA.

Chairman WARNER. That would presume then, that the CIA secreted these people to another area where no MPs or MIs were able to observe. Is that correct?

General FAY. I do not think they secreted them, sir. I believe they were given specific areas within the prison. Nobody was observing them, but they were given those areas for their interrogation by the military intelligence and military police personnel.

Chairman WARNER. Senator Kennedy.

Senator KENNEDY. Thank you. I join all of those on the committee and thank you for your an excellent presentation, General Kern, and thank those that are appearing here. You joined the Army to serve the country in the Army, and I am not sure that this particular task that you had was something that you envisioned, but it is enormously important. We thank you for the service to the United States Army, importantly to the country.

On May 7, 2004, Secretary Rumsfeld testified before the committee about torture and other abuses at Abu Ghraib, and he testified before the House Armed Services Committee that same day. Several of his top aides testified in subsequent hearings. Secretary Rumsfeld told this committee that a "small number" of U.S. military perpetrated the abuses. In the House, he said a "few members" of the U.S. military were responsible. Then on May 24, President Bush said that the scandal involved disgraceful conduct of a "few American troops."

It is now clear, however, that the responsibility for these abuses does not simply lie with a few bad apple soldiers. Your report, General Fay, identified 54 MI/MP medical soldiers and civilian contractors who had some degree of responsibility of complicity in the abuses that occurred at Abu Ghraib. That is in the Fay report, pages 7 and 8. You found that, "leaders in key positions failed properly to supervise the interrogations at Abu Ghraib." That is on page 7. You identified, "serious systemic problems that contributed to the volatile environment in which the abuse occurred." These systemic problems included, "inadequate interrogation doctrine and training, an acute shortage of MP and MI soldiers, the lack of clear lines of responsibilities between MP and MI chains of command, the lack of clear interrogation policy for the Iraq campaign, an intense pressure felt by personnel on the ground to produce actionable intelligence from detainees." All of that on page 8.

Now, Secretary Rumsfeld also told this committee that the abuses were brought to light by Specialist Joseph Darby in January 2004 and that the military chain of command acted promptly

on learning of those abuses. This claim too was false. Senior leaders had ample warning that these abuses were occurring long before January 2004. We have the Red Cross report that lists 13 of them prior to January and then 3 that came in January at the same time of the Darby reports.

As General Jones found, indication and warnings had surfaced at the CJTF-7 level, General Sanchez's command, that additional oversight and corrective actions were needed in the handling of detainees, including at Abu Ghraib. That is in General Jones' report on page 12.

The ICRC reported on abuses in the prisons as early as May 2003 and during a visit to Abu Ghraib in October 2003, Red Cross inspectors were so upset about what they found, they broke off their visit and demanded an immediate explanation from our military authorities. Yet, the worst abuse at the prisons occurred during the next 3 months from October to December 2003.

The repeated warnings of the Red Cross should have rung loud alarm bells. Instead of correcting the abuses, the military officials responded by trying to limit access by the Red Cross and by hiding prisoners from Red Cross inspectors, a clear violation of the Geneva Conventions.

So, General Kern, based on the results of your investigation, is it not fair to conclude that Secretary Rumsfeld and his aides misled this committee and in turn misled the American people when they claimed that only a few low-level soldiers were responsible for the abuses and that the military leadership responded quickly and effectively to the abuses as soon as they were reported?

I have been listening to the reports this morning. You are talking about the change as soon as we had the cessation of hostilities. That reminds me of President Bush being out on that aircraft carrier saying, "mission accomplished," May 1. You are talking about the change, the cessation of hostilities. We expected more support from our allies, General Jones said at that time. This is a clear misrepresentation, a clear miscalculation of what was going to happen in Iraq at that particular time, and the Army is taking the brunt because of failed oversight and leadership in the civilian area. I believe that.

When you say that there is a confusion of policies, the importation of policies from Guantanamo and Afghanistan into Iraq, these were policies that were brought in there at some time by who? Who is getting held accountable besides those members of the Armed Forces that were actually in those prisons? Who is getting held accountable for the failure of providing leadership at the top level? I think we have some responsibility of finding out that as well.

That would be my only complaint about the excellent reports that you have given is that there is some civilian authority up on top and those are individuals that are not being held accountable and the service men and women that are down at the lower level of the line in the chain of command in the military have been left holding the bag, whether it is the shortage of troops over at Abu Ghraib, the shortage of having MPs over there, the shortage of training, the shortage of oversight, the miscalculation in terms of other allies coming in. When will the American people understand where true responsibility lies?

General KERN. Senator, what we reported was a clear differentiation between those people who were culpable for the crimes, as we reviewed them, and those who were responsible. We do hold the chain of command responsible, and specifically we asked Lieutenant General Sanchez where he was getting a great deal of this pressure from, as has been previously reported. His answer to us was that he was generating that pressure. In looking back at both what General Fay had found earlier, in terms of this, and the circumstances that General Sanchez found himself in, it is clearly understandable that he would generate pressure to produce intelligence. He was being attacked. He owed that to his soldiers to protect them, and he demanded of his chain of command their response.

The failure took place, in my view, in that there was no clear chain of command down to the interrogators, and so they were seeking this information. How do I respond to this pressure and at the same time do it within the limits of the authority that we have? So we found, as we reported, a number of documents going back and forth trying to clarify that. They never did clarify that to our satisfaction, and so you end up with a few people at the bottom without the clear direction that they needed.

Unfortunately, the way we have laid this out in our structure, the military police have a clear chain of command and they understood that there was a battalion commander there responsible for the health and welfare and the operation and security of that detention facility. Did he do his job well? No, and that has been reported by General Taguba and others.

Second, in the military intelligence, that did not exist. There is no clear distinction of how that chain of command goes. So the pressure went directly from Lieutenant General Sanchez, and his chain of command to the CENTCOM commander to the Secretary of Defense. So there is a clear chain that he has there, and the next person in the military intelligence is the interrogator.

Now, in our view that is not right. It should be fixed. There should be clear accountability. Regardless of that, there are non-commissioned officers and there are officers who we expect to have exerted leadership and discipline, and they failed to do that.

Senator KENNEDY. Just to follow up, because my time is up, if General Sanchez felt this pressure because of increasing activity and threat to his troops and pressure because of Abu Ghraib, why in the world did he not ask for more troops and more support so we find that out who has responsibility?

General KERN. His staff, through him was, as reported previously, asking for additional help, and that is why they brought in General Miller. That is why they brought in General Fast. The issue is, did it get there in time? I would let General Whitcomb comment.

General WHITCOMB. Senator, that is absolutely right. If I go back to the comments earlier on the June-July time frame, as we saw the mission evolving from a stability and security operation, we saw an increasing insurgency that General Abizaid identified in July, not fully there but certainly increasing from what we had expected, as we saw the increased support required from the CPA, all these things had CJTF-7 working with the CENTCOM staff on

how could/would we man. What were the requirements? They were more than just requirements for people. As we well know, they were high demand/low density skill sets such as military police, such as military intelligence, such as planners to assist both the CJTF-7 staff and the CPA staff, do that necessary work.

So this dialogue of working the joint manning document was one of an ongoing dialogue between General Sanchez's staff and the CENTCOM staff and the Joint Staff who was also a part of this process. The Joint Staff needed a finished document in order to go to the Services to man the force, but they were at least in the process and knew what was going to be coming up the pipe.

The other piece of it, Senator, that complicates the matter is where do those folks come from, very reliant on individual augmentees? So to bring a soldier, sailor, airman, or marine on active duty and get them prepped to go in takes a period of time. So there is some lead time in this process to be able to get the required forces in.

But the bottom line is this was an ongoing dialogue. We recognized from the CENTCOM level, in daily conversations with General Sanchez and his staff, that there was going to be a requirement for more troops, and that was part of what drove General Abizaid's decision to keep the 1st Armored Division and the 2nd Armored Cavalry Regiment in theater to help the situation.

Senator KENNEDY. Thank you. Thank you, Mr. Chairman.

Chairman WARNER. General Kern, I have to interject here a minute. You were brought in as a four star to make judgments with regard to four stars and below. General Sanchez, as a commander, had a degree of accountability down the line for his actions. Have you and your group found any deficiency in the fulfillment of his responsibility as a commander? Have you found professional failure on his part in discharging his duties, and how would you characterize it?

General KERN. Mr. Chairman, I would characterize Lieutenant General Sanchez as a hero.

Chairman WARNER. As a what?

General KERN. As a hero. He was given numerous tasks to accomplish both in supporting Ambassador Bremer and the CPA and rebuilding an Iraqi government; establishing those ties to the Iraqis at the same time that he was fighting this war against the growing insurgency. So we are focused on a specific set of circumstances here in which we found some shortcomings in his responsibility as a commander, but overall, one would have to step back and see what we asked him to do. I find that, overall, we asked him to do a great deal and he accomplished almost all of it.

We found in particular in this case he published a number of documents that said to treat detainees humanely. We found that he, as a three-star commander, took his time to go down to Abu Ghraib on numerous occasions because they were being attacked and he was dissatisfied with the security at those operations, and he took action. He had some strong comments with General Karpinski. That has been reported previously by General Taguba. He then took an unusual action of taking the MI Brigade Commander and assigning him a task for security of the facility.

So we find that while we hold him responsible for the things that did not get done, there were many things that he did do to try to improve intelligence, improve security, and treat people the right way. When he did find that things were reported to him, he immediately assigned General Taguba to do an investigation. When General Taguba came back and said it goes beyond this, he immediately assigned General Fay to do an investigation. When he found that it went beyond the levels that General Fay was asked to look at, he asked to be recused from that and bring somebody else in. So I think his actions are very honorable.

Did he do it all right? No. Do we all do everything all right? I doubt it every day. But he was given a very difficult task. He accomplished the majority of what he was asked to do, but we did find shortcomings in this one specific case.

Chairman WARNER. Thank you, sir.

Senator Inhofe.

Senator INHOFE. Thank you, Mr. Chairman. I have a little different view of this whole thing. I think everyone is aware of that. I would like just to review and maybe put something in perspective certainly the media has, I believe, intentionally not put in perspective.

On April 28, the media broke a story about the abuses that were occurring in Abu Ghraib, in the prison in Iraq. Then pictures were released of American soldiers committing these acts of abuse and Iraqi detainees in the prison. Many people expressed outrage at this time, and the media particularly did. They were acting as if the Army had. They were demanding they take some action as if they had not already taken action. I think what few people realize is that long before April 28, the Army had been performing and performing well.

Granted, having come from an Army background, maybe I am a little bit prejudiced, but I know how this works. I did serve in the military justice system as a court reporter many years ago.

But let us just review quickly what did happen. Mr. Chairman, I will try to do this in the time allotted me.

January 13, yes. Those things that people are so concerned about right now and have created such a media frenzy, first began on the report of Specialist Darby on January 13.

On January 14, a day later, the Criminal Investigation Division (CID) conducts interviews. Now, that is starting the day after this is reported.

On January 16, General Kimmit notifies reporters that an investigation had been opened to alleged abuse at the unspecified prison in Iraq. Now, that was the Army taking the initiative to go to the media and give them information as to what was going on.

On January 17, Captain Reese was suspended. That is just 4 days after all this happened. On the 17th, General Karpinski had a memorandum of admonition. I guess that is what I would have called a letter of reprimand when I was in the Army. I assume it is the same thing. That was on the 17th. Colonel Fillibaum was suspended the same day. This all happened 4 days after they first found out about the abuse that was taking place in Abu Ghraib.

On January 19, General Sanchez requested that the CENTCOM appoint an investigative officer to investigate the conduct of the op-

erations of the 800th Military Police, 6 days after the discovery of this.

On January 24, the chief of staff directed that General McKiernan conduct an investigation of the 800th Military Police.

The initial CID report on criminal abuses actually came out 15 days after it first began.

On February 6 and 7, General Taguba and his team conducted extensive training sessions. Now, let us keep in mind this is 3 weeks after it is first discovered. Not only had the investigation started, not only had people already been punished, but they are already in a retraining program, all that happening in the first 3 weeks.

On February 10, they began the Department of Army Inspector General assessment.

Then, of course, on February 23, 17 U.S. soldiers were suspended.

So 5 weeks after it is first discovered, not only was a letter of reprimand issued to General Karpinski, but a captain and a colonel were suspended and 17 soldiers were suspended. I cannot imagine how that could have happened that quickly. I have often said that if we, in the United States Senate, would act that quickly and that responsibly, we would have had our bills passed and would have already adjourned several months ago.

On March 20, charges are lodged against six accused noncommissioned officers (NCO), and then another press conference on that day. Now, that is the second time General Kimmit has had a press conference, going to the media saying this is what is going on and we want everyone to know we have had a press conference.

Then on April 15, the Fay investigation was initiated.

Then on April 28, all of a sudden 60 Minutes comes out with this thing, as if something has been going on, nobody has been releasing to the press, and abuses are taking place, and the pictures then start circulating. It is this "gotcha" mentality that the media has at that time.

Now, keep in mind since that time we have had nine hearings. We have had 14 investigations.

I would like to put three things into perspective. One is that there are some 700 of our soldiers in Abu Ghraib, of which a very small number, and I know that you can debate this, but if you take out the MI Brigade personnel, which is primarily interrogation, that leaves the non-MI personnel at seven and they said they have newly identified some three. So let us say 10. Let us say even 12. I can tell you right now, when I went up and looked at those pictures a second time, because I only could count seven different faces that were accountable for those abuses. But let us just say it is 10. That is 10 out of 700 in that one prison. We have three other prisons, and I think that needs to be talked about. We need to make sure that the American people understand that even though a few soldiers did something that was wrong, that is a few out of a very large number; a very small percentage.

Chairman WARNER. You can take another minute.

Senator INHOFE. Yes, I have to take a little more time. The previous Senator had 12 minutes. I will not take that long.

Second, if you go back to the reign of terror of Saddam Hussein where they go in the prison, they would cut off their hands, they would cut out their tongues, they would do all these things, they had the rape rooms, the beheadings, all these things that were going on, yes, what we did was wrong. Those people have been punished. They have been reprimanded and the Army has acted quickly. But that is a perspective people need to understand. It is a reality.

Third, since the beginning of the hostilities in Afghanistan, over 50,000 individuals have been apprehended by United States military personnel. Only 300 allegations of abuse took place, and there are 66 substantiated cases. That is 66 cases out of 50,000, 1 out of 1,000 roughly. I think that when you realize in that short of period of time, Mr. Chairman, that we have had 45 court martials, numerous article 15s, numerous general officer letters of reprimand, administratively separated 13 soldiers from the Army, 120 of 225 cases closed, 4 article 32s, I just want to say that I applaud you for the quick response for getting into this long before the media got involved in it, and I am very proud. I join Schlesinger when he complimented you folks, as well as the troops, as to what is going on over there and the fine work that you have done. So I am here this morning and I have waited through all this just to tell you that this ex-soldier is very proud of the leaders of today.

Thank you, Mr. Chairman.

Chairman WARNER. I thank you, Senator. I tried in my opening comments to make very clear my own personal view that the DOD and most specifically the Department of Army has shown that it can fairly and pragmatically and thoroughly, I hope, investigate itself. So I thank the Senator for his views.

Senator REED.

Senator REED. Thank you, Mr. Chairman, and thank you, gentlemen, for your effort, but more importantly for your service to the country. I have had the chance to know General Kern for several years and I respect and admire him greatly. Thank you.

Let me go to page 17 of your report, General Jones. In your words, "there is sufficient evidence to reasonably believe that personnel in the CJTF-7 staff, primarily in the Office of Staff Judge Advocate and the JC 2X, the intelligence staff, had knowledge of potential abuses and misconduct in violation of the Geneva Conventions at Abu Ghraib. This knowledge was not presented to the CJTF-7 leadership." I find that statement shocking.

I will again go to page 69 of General Fay's report. "The duty to report detainee abuse is closely tied to duty to protect. The failure to report an abusive incident could result in additional abuse. Soldiers who witness these offenses have an obligation to report the violations under the provisions of article 92, UCMJ. Soldiers who are informed of such abuses also have a duty to report violations. Depending on their position and their assigned duties, the failure to report detainee abuse could support a charge of dereliction of duty."

Who were these officers on the staff of CJTF-7 that had this knowledge and failed to communicate it to the commander?

Let me emphasize something else. This is not just UCMJ. This goes to the values that you gentlemen live with all your life, the

duty of a subordinate to inform their commander of all information, not just the good news, but the bad news. You have cited specifically a failure to do that.

Who are these officers, General?

General KERN. In our report, first we separated responsibility from culpability, as I stated earlier.

Senator REED. Excuse me, General. Under article 92 of the UCMJ, do they have a responsibility to report these abuses?

General KERN. When they know, that is correct.

We found that the ICRC report, which I have referenced, was reported through the staff judge advocate and staff and delivered to General Karpinski. It never made it past that point.

General Wojdakowski, whom we cite in the report, is the deputy commanding general who was responsible for the brigades, which included both military intelligence and military police. That was not adequately addressed, and we cite that in our report.

So, the personnel and the circumstances that you addressed are correct, and we have cited them in our report. I would ask General Jones to comment.

General JONES. Yes, sir, you are exactly right. What I found, under what I considered indications and warnings that there was not specifically abuse but there was sufficient evidence out there that needed to be looked at and inform the chain of command on. Obviously, the legal counsel section in the CJTF staff saw the CID reports and the things they were working on. They get the reports up to the division's subordinate commands. They also got the ICRC report and worked that. So if you put that all together in a cumulative effect, they should advise the commander of the types and the magnitude of the trends that they may have seen and he should have been aware of it, and they did not do that.

Senator REED. They failed to do that.

General JONES. Yes, sir.

Senator REED. How do you then conclude, General, that in light of all of the circumstances, the CJTF-7 staff did everything they could have reasonably been expected to do to successfully complete all their assigned missions? One of their assigned missions was to ensure that the Geneva Conventions and detention policy was appropriately used.

General JONES. Sir, you are exactly right. What I concluded there was because the legal section itself, Colonel Warren was also split supporting the CPA.

Senator REED. Let me ask this specifically. Was Colonel Warren aware of this ICRC report, these potential abuses?

General JONES. Yes, sir.

Senator REED. He did not inform General Sanchez?

General JONES. He did not.

Senator REED. Was General Fast aware of these abuses?

General JONES. She was not aware of it until it surfaced in late December, December 24.

Senator REED. Now, I find this again extraordinary. Here is the chief staff officer responsible for implementation of the Geneva Conventions, interpretation in a very complicated situation, receiving a report from the ICRC of serious alleged abuses, who does not

communicate that to the commander. You find that is a functioning staff?

General JONES. If you look at the system for the ICRC reports, they are handled in confidentiality.

Senator REED. Excuse me, sir.

General JONES. Yes, sir.

Senator REED. That is confidentiality between the ICRC and the greater world. Here is a colonel, Judge Advocate General (JAG) officer, with a report of abuses and he does not communicate that to his commander?

General JONES. He had reports from the ICRC.

General KERN. Senator Reed, I think there are two issues.

Chairman WARNER. Senator, let him finish the answer. I will give you time.

Senator REED. Thank you.

Chairman WARNER. But I do not think General Jones had completed his answer. Had you completed your answer?

General JONES. The other thing I would add is with regard to the human intelligence section within the intelligence staff. The reason I thought that they should believe it, based on my question with General Fast, they were involved with the detention facilities because they were outlining the priorities that were needed from the human intelligence collection, and they had a lot of interface with the interrogators not only at Abu Ghraib but with all the prisons. So they should have known something or heard some feedback, but they did not surface any reports of abuses.

Chairman WARNER. The "they" is two star General Fast and the colonel. Is that correct?

General JONES. General Fast at the time was a one star, sir.

Chairman WARNER. This committee was rushed to put her to two star at some point. But I will take my time. I do not mean to detract from yours.

But when you say "they," you are talking about two officers, one General Fay and the other colonel. Is that correct?

General JONES. What we are talking about is Colonel Warren who is the legal counsel in the staff judge advocate in the CJTF-7 staff and his people. The other is a sub-element, a subordinate element, in the C-2 which is the human resources intelligence (HUMINT) management cell, generally made up of majors and captains. That subordinate element, though, works directly with the collection effort and the human intelligence effort with the interrogators down at subordinate elements. Nothing surfaced out of them. But it appeared to me, in my findings, that their work at the interrogator level, down at the lowest level, should have surfaced abuses if they were known.

General KERN. Could I add to Senator Reed's question?

Senator REED. If I could, I would like to introduce one other aspect.

Chairman WARNER. I will see that you get time to reply, General. Go ahead.

Senator REED. I apologize, but the time is very short. That is one of the frustrating aspects of this. The chairman has done a remarkable job getting us this far, but this is a report of many pages re-

quiring intense questioning, and I apologize if I am a little bit more direct than I should be.

Let me go to page 54 of the report. "Local CIA officers convinced Colonel Pappas and Lieutenant Colonel Jordan that they should be allowed to operate outside the established local rules and procedures. When Colonel Pappas raised the issue of CIA use of Abu Ghraib with Colonel Bolt, Colonel Bolt encouraged Colonel Pappas to cooperate with the CIA because everyone was all one team. Colonel Bolt directed Lieutenant General Jordan to cooperate."

Did Colonel Pappas raise the issues of abuse and violations of regulations by the CIA with Colonel Bolt?

General KERN. Senator, to my knowledge, he did not, but I think there is an issue here of what the word "cooperate" means. Cooperate does not mean violate laws, regulations, and policies. There is a development that was going on here to build intelligence architectures, to build intelligence fusion, and so there are two ways you could interpret those words. Colonel Pappas, in my view, did not interpret it correctly.

Senator REED. Did Colonel Pappas relate, as it appears in this statement, that the CIA was operating outside the established local rules and procedures?

General KERN. We believe that they were and that is what we found out after the fact, and that is why we have asked for that particular piece to be further investigated.

Senator REED. I understand that. Let me ask it another way. Was Colonel Bolt, because Colonel Pappas told him, aware of potential abuses at Abu Ghraib? Here is a commanding officer in a very difficult position who is making difficult decisions every day, and I think the first response of any commander is to go to his higher commander or the staff and ask for the commander's guidance. What do I do when the CIA walks in with a prisoner? You are suggesting that Pappas never did that, that he simply came in and said they are not following rules? He gave no specific examples?

General JONES. Sir, let me add some clarification, if I may. When the initial request for the CIA to use facilities, not only at Abu Ghraib but at our detention facilities manned by our military police, General Fast directed Colonel Pappas to consult the commanders of the military police to see if they had a problem with that.

Now, subsequent to that, there is no documented memorandum of agreement between CJTF-7 staff and/or any other agencies to do that. My assumption and what I read was that Colonel Pappas coordinated with the military police who were in charge of the detention facilities to see if they would accept that request. He himself was not in charge of the detention facility.

Senator REED. But it says specifically that he informed the staff of abuses by the CIA overstepping regulations and established local rules. That is what I read. Is that right, General Fay?

General FAY. Sir, I do not believe that it reads that they knew about abuses. My recollection was the conversations related to the control of the detainees and the lack of accountability of the detainees. There were never any conversations relating to the direct abuses. It was the ghost detainee issues, of bringing them in, undocumented.

Senator REED. Which is a violation of the Geneva Conventions?
General FAY. Which is a violation but is not——

Senator REED. Now we are making a very nice distinction between the abuses and other violations of the Geneva Conventions. As I read your report, subject to article 92 of the UCMJ, those are abuses that have to be reported. Did Colonel Bolt have knowledge of those types of abuses, the ghost detainees?

General FAY. We did not consider that, nor are they one of those 44 that we enumerated as abuses. That did not meet our definition of abuse when we were writing the report.

Senator REED. So you never asked General Fast or Colonel Bolt whether they had specific knowledge of ghost detainees.

General FAY. Yes, we did ask them that.

Senator REED. What did they say?

General FAY. General Fast did not know about the ghost detainee issues until later on. When Colonel Bolt had that conversation with Colonel Pappas, they had a conversation about what was occurring with the CIA bringing in undocumented, unaccounted-for detainees. Colonel Bolt did know that that was going on.

Senator REED. What date was that, sir?

Chairman WARNER. Senator, we will come back on a second round here and you will have that opportunity.

Senator REED. May I have just the date, sir?

General FAY. I am actually not sure. I would have to go back and check what the statements say. I do not remember what specific date it was.

Chairman WARNER. This is an important line and I intend to return to that and the role of General Fast in this matter.

Yes, Senator Sessions.

Senator SESSIONS. Mr. Chairman, thank you and I could not agree with Senator Inhofe more. I agree with former Secretary Schlesinger and his report and the article he put in the newspaper, the Wall Street Journal, Senator McCain read from, that our soldiers have performed exceedingly well. In situations such as this, under the stress they have been under, mistakes are going to happen. There is just no doubt about it.

Secretary Schlesinger, who has been around a long time, said the vast majority of our force has behaved in Iraq with extraordinary forbearance, including countless acts of kindness. In this respect, its performance has been vastly superior to that of World War II, Korea, and Vietnam. While we did not spell this out in the panel's report, I can only say, in light of some of the public commentary, that it deserves emphasis and repetition. He put in capital letters our troops have performed well, and you certainly reacted immediately.

General Sanchez, General Kern, I agree, is a hero. That is one of the most difficult circumstances for any commander to be in. I visited with him in August a year ago and saw the stress and demands that were on that fine general. I bet he did not get a half a dozen hours sleep once in 6 months, trying to save and protect his soldiers, and he had pressure on him to gain intelligence. We are here on this committee blaming the CIA for not having enough intelligence. We should have had more intelligence. Intelligence saves lives.

We need our soldiers, our interrogators to stay within the bounds of law, and I salute you for taking firm steps to make sure this happens. We have not covered it up. We brought it forth. It was announced immediately when the matters were brought forth, and I believe steps have been taken to see that it does not happen again. We do not need to discourage, General Kern, as you noted, or demoralize soldiers who are out there conducting inquiries every day.

We have had 8 reports so far, 3 more anticipated, over 15,000 pages received thus far, 950 interviews, 43 congressional briefings and hearings on this subject, and we have a war on. Soldiers are out there, at risk, this very day in hostile combat. I want to express my strong support and appreciation for that.

With regard to the ghost detainees, General Fay, I think you made the point. I was a Federal prosecutor and I know when you get an organized crime or big drug case, certain people you may apprehend are very sensitive. Maybe with a few more days, you could break them or get them to roll on the people they deal with. Maybe they are in danger because they have already given you information.

Now, the CIA did not have a prison of their own, I assume, in Iraq. They had to put people somewhere. Could that be some explanation for why they might want to handle these prisoners in a different way than you would normally handle them, recognizing it is important that documentation be kept of prisoners?

General FAY. It could be one of the explanations, sir.

Senator SESSIONS. Do you have any information, General Fay, that any of those soldiers that the CIA handled were abused physically or otherwise?

General FAY. There was one instance in one of the 44 cases that we talked about. There was abuse that did occur before the detainee was brought into Abu Ghraib, and because the detainee was not properly processed into Abu Ghraib, failed to receive a physical, and indeed, that detainee died soon after being brought into Abu Ghraib.

Senator SESSIONS. How do you see the CIA's human intelligence operation? Was it effectively moving the information forward so that commanders in the field could utilize it?

General FAY. Yes. From my knowledge and my experience working with CJTF-7, and also from my visits there on the centralized processing of the intelligence that General Fast brought into country, they were very effective in Iraq.

Senator SESSIONS. General Kern, when you deal with intelligence gathering operations, as you were in this area, and trying to maintain discipline in a prison, how important is it to the commander, though, in the field that the intelligence they gather gets to them so that they can utilize it? Are we doing a good enough job? I know we are pointing out the errors that have occurred here, but can we approve the ability to get information to the commanders in the field so that it can save lives?

General KERN. The answer is yes, we can. This has always been one of the challenges of how you collect information. We teach our soldiers to do tactical intelligence primarily focused on enemy prisoners of war. The detainee puts them into a different category and

makes it even more challenging to collect that right intelligence. But the intelligence collection process begins at the point of capture. Initial interrogations that take place and moves all the way back to the strategic level, which is really the part that we are talking here at Abu Ghraib.

One of the challenges and one of the frustrations of the commanders at the lowest level is once they give up a detainee, they rarely get the information flowing back down as to what is further developed. One of the challenges that was being taken on here, then, was to complete that loop so that information not only went into the intelligence collection process but was also disseminated back down to the operational commanders at the division brigades, battalions and below. That was a challenge which, from my perspective, has been improved considerably over the last year since this investigation took place and since most of these abuses took place. I would ask that General Whitcomb might comment on that because he has firsthand knowledge.

General WHITCOMB. Senator, that was one of General Abizaid's priorities during this time frame, the summer time frame of June-July-August. He challenged his subordinate commanders to work this fusion of intelligence. His concern was what happened at the point of capture with the tactical unit and as that captured individual went through the process to some detention site, how did we close the loop back to that battalion, brigade, and company commander so that he could utilize that information. General Abizaid's thought was that we were not doing very well at closing the loop.

To some degree, he was concerned that as a prisoner was passed off, the tactical units did not provide as much information as they should have or could have to enable interrogators at the next level to be able to continue that kind of process. So that was really his emphasis with his subordinate commanders, how do we improve that process? That was really the genesis for the joint interrogation and debriefing center, in putting that together, so that you could get intelligence operators from all the intelligence sources, HUMINT, as well as the other intelligence capabilities, together in one room to really maximize that kind of capability. So that was a part of the dynamic that was changing during the summer months, as the insurgency that we saw unfolding was gaining some momentum.

Senator SESSIONS. You are confident that following the approved policies of interrogation are now being handled and that with this kind of more sophisticated work toward sharing intelligence and moving intelligence in the right way through the system, we are able to function well at this point?

General WHITCOMB. I am, Senator.

Senator SESSIONS. I do share General Kern's concern from my previous visit to Iraq earlier this year, the week of the Fourth of July, that there was a feeling among a number of people expressed to me, that they had to be more careful maybe than the law allowed because they might be prosecuted or investigated or hauled before Congress. We do not need to intimidate them from doing anything that is legal and proper to gain the most amount of intelligence we can get. At the same time, we need to stay within that rule.

I think the Army is doing an excellent job in trying to accomplish that difficult task under very stressful circumstances. We thank you for your service.

Chairman WARNER. Thank you very much, Senator. I associate myself with your remarks there.

Senator Ben Nelson.

Senator BEN NELSON. Thank you, Mr. Chairman.

Let me also thank you for your service and for a very thorough investigation of a difficult set of circumstances. What you are really proving is that if you do not have rules, you nearly have a state of nature where almost anything goes. So, I certainly appreciate the fact that you want a crisp set of rules and an understanding, fusion of intelligence, but to avoid confusion about how you go about getting it. I certainly concur with my colleague from Alabama when I say that you do not have to demoralize the system in order to have a crisp understanding of how you go about getting intelligence and gathering it from a variety of sources, including HUMINT.

In this case, I certainly appreciate, as well, the distinction between culpability and level of responsibility. General Kern, I agree with you about General Sanchez. A very difficult set of circumstances in which he was placed, performed very well. I understand what you are saying in the sense that there may have been some shortcomings in what he did, but you are probably not saying, well, nobody is perfect. You are identifying an area that probably could have and should have been handled differently, but in the fog of his circumstances, it was difficult to get it done. Is that an accurate description of what you were saying?

General KERN. Yes, Senator, I think that is fairly accurate. But it is not just the fog of it, he did take positive actions.

Senator BEN NELSON. I am not suggesting he did not, but the shortcomings that you have alluded to would be different than saying nobody is perfect.

General KERN. I think that is correct. General Sanchez was given a very difficult mission, and as we have pointed out, the mission he was given turned out to be quite different than the mission he actually was accomplishing in his support to the CPA and the fighting of an insurgency. So he used all of the best capabilities that he had, and at the same time we found that he did a significant amount of work to improve the quality of the operations. He brought in General Fast and he brought in General Miller to improve detention and intelligence operations. He implemented many of their guidance and instructions. It has improved, it has been reported. He made statements and published orders that told people to treat detainees properly. He investigated things when he found them out. There were some things he did not find out that he should have, we have pointed that out.

Senator BEN NELSON. Excuse me. That is where you get the responsibility versus culpability.

General KERN. That is correct.

Senator BEN NELSON. I understand the distinction. I just want to make sure that that applied here as well.

General KERN. That is correct, Senator.

Senator BEN NELSON. Let me also say that I agree with my colleague from Oklahoma that we ought not to overreact to this situation, but I certainly appreciate the fact that you have not underreacted to it. I think your approach has been appropriate with the chain of command. I think a distinction exists between the chain of command with the uniformed officers and personnel versus, let us say, a chain of command of the civilians above. Your role was to investigate from four stars below, not the Pentagon above. Is that also a fair statement?

General KERN. I think it is a fair statement, but I would also tell you that if we had found that there was clear direction for somebody to do something illegally, we would have reported it, regardless of where it came from.

Senator BEN NELSON. Yes, that would be culpability again as opposed to responsibility.

General KERN. Correct.

Senator BEN NELSON. So the question of responsibility above the chain of command in uniform is still an open question at this point in time from your reports because that is not within your responsibility. Culpability but not responsibility. Is that fair?

General KERN. That is fair, Senator.

Senator BEN NELSON. General Taguba, I have been concerned about the suspension of General Karpinski from the very beginning. I think there are questions about whether her command was severed and whether she was in a position to make a determination. She said she had words with, I believe, General Sanchez, and he says that did not exist. Have you had any further clarification on that different set of circumstances and facts?

General TAGUBA. Not that I have been informed, no further on that.

Senator BEN NELSON. Has anything occurred and come up in the investigation that would change your mind about whether General Karpinski had the responsibility here, whether responsibility was severed by the set of circumstances that we now understand with the Military Intelligence as well as the CIA intelligence situation?

General TAGUBA. No, sir. I stand firm with our findings and our recommendations.

Senator BEN NELSON. I thank you very much once again for your answers to the questions. I would ask the chairman if there is a way to follow up on the civilian side below with the contractors, those who are now going to be reported to the DOJ, to make sure that while it works within the administration of justice for uniformed personnel, there is going to be a question here of what happens, if anything, to the civilian contractors.

Chairman WARNER. The Senator is correct. This committee will continue to exercise its oversight as to how the question of accountability was administered by the overall executive branch with regard to non-military participants.

Senator BEN NELSON. I thank the chairman. I think that is our responsibility for oversight. It is perhaps not exactly part of the armed services but certainly connected.

Chairman WARNER. I thank the Senator.

Senator BEN NELSON. I thank you. I thank you, gentlemen.

Chairman WARNER. The Senator from South Carolina.

Senator GRAHAM. Thank you, Mr. Chairman.

I too want to thank you for a very thorough report, and I believe corrective action is being taken in a positive manner. I know you have been in sort of a political tennis match here and I do not want to ask you to comment on what we should be doing. That is up to us. I do appreciate the inputs you have given.

But, General Kern, to me it is important that we learn from the mistakes of this problem. Do you agree with that?

General KERN. Senator, I completely agree. Of all these investigations, I believe, and General Jones may add to this, that there are more than 220 actions which have already been taken to fix problems identified through these investigations.

Senator GRAHAM. One of the things we have learned apparently is you do not need to torture people to get good information. Is that correct?

General KERN. That is correct, Senator.

Senator GRAHAM. Not only is it legally and morally wrong, it is not the most effective technique.

What hangs in the air for me, that I have a hard time coming to grips with, is that a blind person could see that we do not have enough people in that prison during the time in question to effectively elicit good intelligence.

General Fay, did General Miller tell General Sanchez you are understaffed?

General FAY. Sir, the situation when General Miller appeared there in Iraq was at the later part of August, the beginning of September—he was only there for 9 days. At that point in time at Abu Ghraib, there were only 600 and some-odd prisoners at Abu Ghraib. They were not overwhelmed at that point in time. The overwhelming population did not occur until the October-November-December time frame. So the situation dramatically changed. General Miller did have a conversation regarding different types of people and more people being needed, but not in the severe numbers that it later became after General Miller left the theater.

Senator GRAHAM. That is a very good point.

About the dogs, Colonel Pappas is saying, or at least has said in the past, that he was told to use the dogs as part of interrogation. You believe that was a misunderstanding. Is that correct?

General FAY. That is correct. I believe that was a misunderstanding between Colonel Pappas and General Miller.

Senator GRAHAM. General Taguba, do you believe that General Karpinski lied about what she actually did?

General TAGUBA. Sir, in terms of her understanding? Sir, she had made some you might call non-disclosing type of statements because she had, at least from the ICRC reports, that the commander had been briefed and subsequently had informed her.

Senator GRAHAM. Did she lie about how many times she went to the prison?

General TAGUBA. Sir, I believe based on the information that was provided to us that there was some question of the number of times she visited the prison.

Senator GRAHAM. General Kern, the general officers, are they allowed to lie?

General KERN. No, Senator, and it does not make any difference whether you are a private or a general officer. None of us are allowed to lie.

Senator GRAHAM. That is the point. I think we will have failed the privates and the sergeants if the only people who are court martialed here are privates and sergeants.

Dereliction of duty will be redefined one way or the other after this investigation.

General Fay, when the prison was overwhelmed in terms of the number of detainees, did anyone at that time in October or November tell General Sanchez you do not have enough people to manage this problem?

General FAY. Sir, I do believe it came to his attention. Both by General Karpinski and also from the intelligence staff, they were telling him. In fact, there was a request for forces that was put in for, I know, the MI personnel for additional personnel. That request for forces was responded to. The difficulty was it takes a long time to find the personnel throughout the rest of the Army, notify them, and then move them to Iraq. But early on, it was in October, that the MI personnel recognized a severe shortage that put in a request for forces, was responded to. Those troops began to arrive in November and then followed on. More soldiers became available after that.

Senator GRAHAM. What percentage of the MI operatives or soldiers during the abuse period were involved in failing to report or actually involved in abuse?

General FAY. Sir, do you mean those present there? Of those present MI soldiers, they began in the early parts of only having 14 present, and ultimately by February there are about 160 present.

Senator GRAHAM. But from October to December, how many were present?

General FAY. It varied because they were coming in in bits and pieces two, three, four, five at a time. So it probably went from probably around 30 or 40 up to, by the end of November, probably raised to somewhere close to over 100, 120.

Senator GRAHAM. My question is, given the close confines of this situation, the limited number of people, do you believe that there are only 23 people who failed to report? How could the others not know, given the extent of what was going on?

General FAY. You have to understand the circumstances. These abuses, most of them were occurring in the hard site, which had very limited access. Not all of those soldiers that we just spoke about had access to the hard site area. So it was impractical to believe that they were going to see what was going on in those areas that they did not even frequent.

Senator GRAHAM. How did the ones who wound up there, the MI people, get into the hard sites?

General FAY. They would be doing interrogations at the hard site in some of the shower areas of the hard site because there was an inadequate number of interrogation booths available. So they would show up there at the hard site and they would be granted access by the military police personnel to do their interrogations.

Senator GRAHAM. My final question. General Kern, do you know General Shinseki?

General KERN. Yes, Senator, I do.

Senator GRAHAM. He made a comment at one time, I cannot remember when, that we would need 200,000 people, or whatever number, to do this operation effectively. Have you ever experienced, believed or perceived that if a commander anywhere in theater asks for more troops that that would be unfavorably viewed? Or a commander would be reluctant to do so because of what happened to this general?

General KERN. I do not know that I can put myself in everybody's mind who is in theater. We teach our military commanders pretty ruthlessly to do a mission-to-task analysis, and we go through a process of understanding what is required to do the job. When you are given a job where you are not given the resources to do it, we expect the commanders to go back and ask for them. So despite all of that, I believe that our commanders will ask for the resources they need.

Senator GRAHAM. If you do not, you let the troops down, do you not?

General KERN. That is correct, Senator.

Senator GRAHAM. Thank you.

Chairman WARNER. Thank you very much, Senator.

Senator Dayton.

Senator DAYTON. Thank you, Mr. Chairman.

General Kern, you stated in your testimony that we set our course to find truth, not to whitewash or to convict those who are not incriminated. I respect that that is your undertaking and your sincerity. However, the report that we have here that has been released publicly is 176 pages, the two reports combined unclassified. The two reports in total, we are told, are over 9,000 pages. This is 9,000 pages of paper here. This is 176 pages here that are made public. All the rest of this is classified or secret or whatever, but is not being revealed to the public. This is 2 percent of this amount.

Who makes the decision on classification or release of these pages, and how can it be that out of 9,000 pages, only 176 of them can be made public?

General KERN. I believe that more than 176 pages can be made public. Many of those have been published as parts of other reports which we have included in our report.

Senator DAYTON. How many pages are being withheld of the 9,000?

General KERN. We have not withheld anything. We have given the committee the full report, unredacted and redacted versions.

Senator DAYTON. How many of the pages are being withheld from the press and the general public?

General KERN. I do not know how many. We have given the redacted versions, as far as I know, to the press with the classification taken out.

To answer your original question, there is an original classification authority. I do not have the authority to declassify everybody else's documents.

Senator DAYTON. Who makes that decision, sir?

General KERN. The person who classified the document.

Senator DAYTON. Who classified whatever number—

General KERN. There are dozens of people who have classified different parts of those different documents. I could not tell you.

Senator DAYTON. Just so I understand, not being a military person, the 9,000 pages are completed and those are sent through various channels, and then anybody in those chains of decision-makers can classify and then those that are classified and not released.

General KERN. No. There is a very clear set of regulations that says who can classify at what level, the different classification levels that we use from official use only, all the way up through top secret SCI. Each of those has different regulations and rules about how they can be declassified.

Senator DAYTON. The published press reports that I have reviewed, the Congressional Quarterly, for example, which is considered here authoritative, non-slanted, says here that of the 9,000 pages, 176 are available, are unclassified, are made available to the press and therefore to the general public. This is the document we have here which is 176 pages of a 9,000 page report. I would appreciate, sir, being informed, via the chairman or however, how many pages are being made public, and by that I mean not to the committee. I understand we have. But how many are made public to the general public? After all, it is their tax dollars that are paying for these investigations and these reports. Then, how many are withheld and on what basis they are being withheld.

General KERN. We will comply with that, Senator.

Senator DAYTON. Thank you.

In the testimony today and on this chart that was passed out, you cite that in October 2003 at Abu Ghraib prison, it is under 2,000 according to the chart. It looks to be approximately 1,800 detainees in that month at Abu Ghraib. The Schlesinger report, which we are going to be hearing from this afternoon, says that in October 2003 at Abu Ghraib there were up to 7,000 detainees housed. That is quite a discrepancy, 1,800 according to your testimony today and 7,000 according to this document. Can you reconcile that discrepancy?

General KERN. There are two charts that we have used there, and if you will look at them precisely, the numbers do not correspond one to one. We used the Schlesinger numbers for the total number of detainees. We do report that the number of detainees achieved about 7,000, but it was in November. I would have to go back and look specifically—

Senator DAYTON. In the Schlesinger document, it says here on page 11, in October 2003 Abu Ghraib housed up to 7,000 detainees, and in this chart here it shows less than 2,000. It looks like about 1,800 detainees. I am just saying that is quite a discrepancy, and I am trying to reconcile it.

The point I want to make, and it is actually one I think is in your favor or at least in favor of those who are being charged with whatever it is here, the prisoner-to-guard ratio by this count here would be about 20 to 1. In the Schlesinger report, it would be 78 to 1. I checked with the Department of Corrections and nationwide, of all the prisons in the United States, State and Federal, all levels of security, the average prisoner-guard ratio is 5.5 to 1. In Min-

nesota, it is 4.5 to 1. Those are mostly minimum to medium security prisons. We have two maximum security prisons.

So here we are in Minnesota, 4.5 prisoners to 1 guard, nationwide 5.5 prisoners to 1 guard at all classifications. Here you have a very dangerous situation, people under constant pressure, threat of bombardment, actual bombardment, and a very dangerous prison population, and the prisoner-to-guard ratio is either 20 to 1 or 78 to 1. That to me is begging for serious difficulties.

I guess I am wondering as a matter of military policy, is there a ratio that is subscribed to? Is there a point where an alarm bell goes off and says, hey, we over 5 to 1, we are over 10 to 1, we are over 15 to 1, and we have dangerous, unmanageable conditions?

General KERN. I do not know the precise number how you describe that, but I will tell you that we recognize in the United States Army that we have been short military policemen for the detention operations and we have been converting battalions at as fast a rate as we can to military police to overcome those shortages.

General Taguba I think may have a ratio that is the doctrinal ratio.

General TAGUBA. Sir, the doctrinal ratio was one battalion, roughly 500 to 600 MP personnel, depending on how their tasks were organized, per 4,000 detainees.

Senator DAYTON. I am sorry. 4,000 detainees for 500?

General TAGUBA. Yes, sir, one battalion.

Senator DAYTON. So that would be 8 to 1.

General TAGUBA. Yes, sir.

Senator DAYTON. That would be appropriate. So this spirals seriously out of control here in terms of manageable numbers of prisoners I would say.

General TAGUBA. Yes, sir. That is indicative of the shortcomings in terms of personnel shortfalls at Abu Ghraib at that time.

Senator DAYTON. Mr. Chairman, one last question quickly.

How many total detainees approximately were there during the time of your investigation or the two investigations in Abu Ghraib prison?

General KERN. The total was over 6,000 at Abu Ghraib prison during the period and it is what we show on our charts.

Senator DAYTON. During that time, you documented or there were alleged, I should say, 44 instances of abuse according to the definition of abuse you provide in your testimony.

General KERN. That is right and more than 2,500 interrogations during that period.

Senator DAYTON. Okay, 44 alleged abuses and 2,500 interrogations.

Thank you, Mr. Chairman.

General KERN. Thirteen of the abuses were during interrogations, 44 total abuses.

Senator DAYTON. I see. All right. Thank you.

Thank you, Mr. Chairman.

Chairman WARNER. Thank you, Senator.

Before we proceed to Senator Pryor, I would like to clarify the material that you have there displayed. The classification of much of this material is owing to the numerous ongoing judicial proceedings under the UCMJ. Am I not correct in that, General?

General KERN. Yes.

Chairman WARNER. That is to afford the appropriate protection, innocent until proven guilty, by a number of individuals that are now being investigated. Am I correct that a considerable portion of that relates to some of those trials?

General KERN. The release of the information directly relates to that so that we can continue with due process.

Chairman WARNER. That is correct.

The files are open for inspection by any Senator here on the committee or members of their staff. If the Senator from Minnesota is concerned that there is some material which you feel should be released, I will direct my attention to that to determine whether or not it would invade the UCMJ protections. I do not want to leave this hearing with the impression that the Kern report in any way is put together in such a manner as to preclude public disclosure of facts relevant to the investigation because at the very outset, the chairman with the assistance of the ranking member, we have tried to make available to the public all that information that we feel is relevant without injuring the due process of the UCMJ.

Senator DAYTON. Mr. Chairman, I am not questioning the general or the others who have conducted these reports. That is what I am trying to ascertain. They completed the reports. There are reportedly 9,000 pages in those reports. Somebody else along this line took 8,824 of those out of public view. It is not my role to determine which of those pages should be properly withheld or which should not. But that is over 98 percent of all the pages that are withheld from public view, not from our committee, but from the public, and they are the ones whose representatives, both here and in Iraq, are being judged. I think for those who are conducting the investigation in the broad sense, the military, to be deciding then among themselves at some level what information to withhold from their investigation of themselves from the public and the press I think is bad form, without at least an explanation as to exactly why that was necessary, which is what I am asking for.

Chairman WARNER. A good deal of the explanation is owing to the judicial process in which we must protect the rights of the accused. A committee of the Senate, not only this, but any committee, has the right to petition the executive branch to have matters declassified. Our staffs are now going through that. If I feel that there are materials in there or you or any other committee member, then I will petition for such declassification because I certainly want the public to understand that in fulfilling our oversight responsibilities with this series of hearings, in no way are we condoning the wrongful embargoing of material.

Senator DAYTON. I do not think you are condoning it at all, sir. You have been very resolute in these hearings in getting to the bottom of this. It was not your decision to make, what is to be withheld and what is not. But it is a very high percentage. I hope to serve as long as the chairman in this body, but I do not know if that allows me enough time to go through a petition process with the executive branch under any administration or series of administrations given the realities. So I just point out, though, that that is a very high percentage of pages to be withheld from public view.

Chairman WARNER. I note your concern.

Senator DAYTON. Thank you, sir.

Chairman WARNER. Now we have our distinguished Senator from Florida. You have had a big agenda, Senator, with regard to your State and we all admire the manner in which you and your colleagues are carrying on your responsibilities in these extraordinary times. But we are glad that you found time, as you always do, to join us here with this hearing.

Senator BILL NELSON. I am going to defer to Mr. Pryor.

Chairman WARNER. You can if you wish. Mr. Pryor, then in the sequence, you would be next. We will come back to you.

Senator PRYOR. Thank you, Mr. Chairman. I would like to thank the Senator from Florida for doing that. That was unnecessary.

Let us see. General Taguba, you will be happy to know that most of my colleagues have asked the questions that I was going to ask. But I did have a follow-up for you, and that is you mentioned the 8-to-1 ratio. I think you said 500-ish to 4,000. So that is roughly an 8-to-1 ratio. We had a worse ratio than that in Abu Ghraib. It sounds like significantly worse. Is that due to a shortage of these type of soldiers in our system, or is it due to a lack of planning about Iraq, that we just did not make what we had available inside Iraq?

General TAGUBA. Sir, I recollect there had been comments from those that I interviewed that shortages of personnel not just in Abu Ghraib but in the other detention centers that we visited. It was either a series of folks who had redeployed back, but were not being replaced.

With regard to the shortage at Abu Ghraib, as I interviewed the operations officer for the 800th MP Brigade, that based on doctrinal precepts that he fully understood was perhaps as a temporary measure until he can get further replacements of reallocating forces, MP soldiers within the other three detention centers to help obviate or at least relieve the pressure at Abu Ghraib at the time. He could not come up with a good enough response of why he could not have done that.

Senator PRYOR. So let me make sure I understand your answer. Is it a lack of resources within the system, or was it more of a lack of planning or a lack of availability of American forces inside Iraq?

General TAGUBA. Sir, two things. One was an inability to adjust their planning factors when they assumed the mission at Abu Ghraib, and second was a matter of requesting for additional forces within the command.

Senator PRYOR. So as I understand it then, I am not trying to put words in your mouth, it really was a lack of planning or at least a lack of making the existing resources available where they needed to be.

General TAGUBA. Yes, sir.

Senator PRYOR. General Fay, we have all covered the fact that you found 44 cases of alleged abuse and we talked about the chain of command leading up to General Sanchez and I think in your words other senior level officials on what was going on inside the prison. But at the same time, you did not and your commission here, your group, did not recommend disciplinary action against General Sanchez or anybody else. Do you want to explain why you did not, and how we should understand that?

General FAY. Sir, my role was the 205th MI Brigade and on the 205th MI Brigade soldiers and the contractors that worked with the 205th MI Brigade, we either referred them to the commanders, after we outlined all of the things that we believed that those people did do, or to the DOJ. The individuals above the 205th MI Brigade was not within my—

Senator PRYOR. They were beyond your scope.

General FAY. But it was within General Jones' scope.

Senator PRYOR. General Jones, do you want to answer that?

General JONES. Yes, sir, I can address that. I think General Kern has also talked about the challenges that the CJTF-7 leaders and their staff had. When I looked at it above the 205th command, I looked at it to determine if they had direct or indirect involvement in the abuses and the cases that happened, did they provide clear and consistent guidance, and did they resource the subordinate units for the missions they had given them.

In this case, I found that the leadership above the 205th was not directly responsible for the abuses or the causes of abuses that happened. There are some things they could have done as far as the guidance and the policy memos, making sure that the lowest level soldiers understood what the policies were. But they did fight for resources. They did reprioritize some things and they did publish memos that emphasized that the law of land warfare and the rules of the Geneva Conventions would be upheld.

Senator PRYOR. General Jones, you have had a chance, I am sure all your colleagues have, to look at the Schlesinger report. I would just like to ask is there anything in there that you disagree with? Are all the findings in the Schlesinger report consistent with your findings?

General JONES. I have looked at it. I am trying to think because we had this discussion earlier. I think a couple things that I think I would disagree with, not particularly disagree with because I thought it was a very good report. I think all of the reports that you see come out are very much synchronized.

Senator PRYOR. No. I think the committee understands the spirit in which you are going to answer the question, not to blame anyone or not to—but give me your thoughts on it.

General JONES. I think there are some comments in there that talk about other Services' responsibility in terms of human intelligence, which is something they do not have at this time. So to refer to other Services, when the Army basically has the lead for human intelligence, may not be making the right point.

Senator PRYOR. Anybody else on the panel like to address that?

General KERN. There is one that I do not think we completely agree with because we do not know all the facts that they were using and that is a judgment on General Fast's role. It goes back, I think, a little bit to questions that Senator Reed was asking earlier as well.

We found that General Fast came into the theater to do an architectural assessment and to do work on improving the integration of all of the activities of intelligence activities, and she did a very good job at that, as noted. We have seen significant improvements from the time she showed up in theater until today.

There are a series of vacuums in there which relate to this issue of the ICRC reports and abuses, I think. What we found, and I would ask anybody else to correct me if I misinterpret this, is that General Fast was not in country. She was out for health reasons at the time that the ICRC report was delivered. The Staff Judge Advocate, Colonel Warren, in his assessment of it, delivered the report after he made his assessment to General Karpinski, not to General Fast, because the military police were responsible for the detention operations.

So our assessment is that she did what she was asked to do in terms of improving intelligence activities, and we have seen significant results as a result of that. We do not have the evidence that would suggest that she was overlooking things that she should have.

We also know that she spent a significant amount of time working not just with the CJTF-7 but also with the CPA. What I cannot tell you is if there are other things that Secretary Schlesinger's panel found that may have come from other sources that we do not know.

General JONES. I would add to that. First of all, she is the one that went back after the death of the one detainee in November and surfaced that later on, and she is the one who went back to the agency and told them they will comply if they detain personnel in military facilities. So she was the catalyst for that. She was also the one to ensure that they investigated that incident and it was properly handled. It did not get pushed aside.

I would tell you I had to be involved with the leadership above the 205th, and probably the two people that stand out that are totally taxed with their duties, responsibilities; particularly in supporting the CPA and the Iraqi people, building a coalition, building the intelligence fusion, and getting those reports that Senator Sessions talked about from tactical to the strategic and the reach-back capability in place because they did not have the communications and did not have the equipment and the personnel, the two people that stand out not only is General Sanchez but is General Fast. She did yeoman work in theater. That was shown in her relationship with the coalition and the allies.

General FAY. Sir, just one point on your original question about some of the factual data that is contained in the independent review by Dr. Schlesinger. There was one issue in the beginning of his report. He states that none of the abuses occurred during interrogations, and we found that there were 13 instances. Dr. Schlesinger has corrected that in his statement to this committee.

General KERN. Could I make a correction to what I was told? General Fast was out of the country during the development of the policy memos. She was there when the ICRC report was given, but it was not given to her. It was given to General Karpinski.

Senator PRYOR. Thank you, Mr. Chairman.

Chairman WARNER. At this juncture, I will ask the committee to bear with me because the Senator asked a question and one of them was, did you disagree in any way with the Schlesinger report? I would like to read a short paragraph with regard to the findings of the Schlesinger report specifically relating to General

Fast, "The CJTF-7 C-2," that was her designation as the intelligence officer for General Abizaid. Is that correct?

General KERN. Yes.

Chairman WARNER. "Director for Intelligence failed to advise the commander properly on directives and policies needed for the operation of the Joint Interrogation and Debriefing Center (JIDC) for interrogation techniques and for appropriately monitoring the activities of OGAs within the joint area of operations."

Now, given that we must move along, I would like to have you take for the record the question of our colleague from Arkansas, with regard to whether you agree or disagree and this written report of Schlesinger and reflect on it among yourselves and come back and provide for the record your response, because General Fast, whom I incidentally met on the occasion of my most recent visit over to the area, impressed me. This committee was asked specifically to promote her out of the normal order of promotion from one star to two star. We did so at the request of the DOD. She has now been reassigned in the normal course of events to a very important post within the intelligence structure of the Army. Is that correct, General Fay? She is now the head of the intelligence school?

General FAY. That position is pending, sir.

Chairman WARNER. Pending, but anyway, it is under consideration.

General FAY. Yes, sir.

Chairman WARNER. Therefore, I think it is important that clarification be brought to her professional performance at the time she served in her capacity with the Central Command. Do you have some comments on that, General?

General WHITCOMB. Chairman, I would just make one correction, sir. She was the C-2 for General Sanchez for CJTF-7.

Chairman WARNER. Did I misspeak?

General WHITCOMB. Yes, sir.

Chairman WARNER. Fine. General Fast was under General Sanchez. That is correct.

Thank you for the questions, Senator Pryor. We have Senator Nelson.

Senator BILL NELSON. Thank you, Mr. Chairman.

I would like to ask a question about lessons learned, and I would like for you all to reflect in your professional judgment on the embarrassment that we suffered in Kosovo as a result of detainee abuse. Why were the lessons that we learned from that not apparent and taught that would be available for people to avoid something like this? Why do we not just start with you, General Whitcomb, and go right on down?

General WHITCOMB. First, Senator, I would say I am not familiar with the detainee abuse issue in Kosovo.

But I would comment on our lessons learned and what the Services do, specifically in the Army, in analyzing operations. This has been a very painful lesson learned that has resulted in a much smoother operation, but it has caused great damage to our Army and our Nation.

We went into this operation expecting the detention operations would be more in the flavor of enemy prisoners of war. So I think

that was a good planning assessment. It was an integral part of our plan, but it is a different dynamic than what we, in fact, faced on the ground with an insurgency and the type of internees and detainees that we are seeing, everything from former regime elements to criminals to terrorists to foreign fighters and to innocent civilians that are wrapped up.

What we have done, Senator, throughout this process is to make course corrections. They have not been as rapid as any of us would like them to be, whether it is the number of linguists, whether it is the number of MI professionals, whether it is the number of military police that are required to do the job. But throughout this process, we have, from a CENTCOM perspective, recognized where we had shortfalls and have taken steps to correct them.

We have also worked this, not only in concert with CENTCOM's subordinate commands but also with the Joint Staff and the Services, to try and identify those.

As you also know, Senator, there was a very robust joint lesson learned effort before the war that was embedded with Central Command and our units headed by Joint Forces Command. So we did, in fact, have an apparatus in place that was able to feed back to the Services, feed back to us at Central Command on a pretty rapid basis when they saw areas that we should and could address.

Senator BILL NELSON. I am specifically interested in lessons learned from Kosovo, and you are not aware of any abuses in Kosovo.

General WHITCOMB. Sir, I am not.

Senator BILL NELSON. It was widely reported.

How about you, General Fay?

General FAY. No, sir. I am sorry I did not know of any abuses that occurred in Kosovo.

Senator BILL NELSON. How about you, General Kern?

General KERN. Sir, I know of abuses that occurred in the Balkan theater, but not associated with detention in interrogation operations. But we have made a comparison of the Balkan operations to what is going on here, and the part that we find that is significantly different and why it is hard to apply lessons learned from one theater to the other is one of scale. So we have some very good MI fusion efforts that have been going on in that theater for some years, coalition and multiple agencies. So, there are some very good lessons learned that we did work through this, but the scale is so different and the ability to put the resources on it then with that scale is what we believe is significantly different here. It goes back to the earlier questions about having enough people, having enough capability in terms of equipment, et cetera so that you can do it. So the lessons learned from Kosovo are different significantly from what we saw in Iraq simply because of the scale and the number of people that you had to put through those operations.

Senator BILL NELSON. There were abuses at the time of capture. Are you specifically familiar with those that occurred in Kosovo?

General KERN. I am not.

Senator BILL NELSON. General Jones?

General JONES. Sir, I am vaguely familiar with them, and my understanding is appropriate action was taken for the people involved. I would have to go back and look at them. I will tell you,

similarly here, if proper discipline and training and doctrine was followed, abuses would not occur.

Senator BILL NELSON. General Taguba?

General TAGUBA. Sir, I am not familiar with what happened in Kosovo other than the genocide types of events that happened there.

But with regard to lessons learned at the onset of the training of our MP and MI personnel prior to their deployment, the conditions changed where detention operations, as we experience today, is not exclusive of just those two functions and operations. That has now become an interagency interactive, coordinated action that goes just beyond those MPs and MI, medical, legal, OGAs and the like, inclusive of course of proper coordination and the proper guidance meted out to those individuals and also the units and the commanders.

Senator BILL NELSON. Mr. Chairman, I will not continue this but I would like to leave the record open for further inquiry because I want to make sure that the information that I have is correct. I had understood that it was widely understood about the abuses that occurred in Kosovo, and if that is factual what I have said, then it would be a concern of mine that the senior leadership of the United States Army did not know about that in applying those lessons learned to prevent similar kinds of situations, albeit as General Kern said, it is a different situation, different theater, different in scope. So I will pursue that, Mr. Chairman.

Chairman WARNER. Thank you very much, Senator. Again, thank you for joining us today.

Gentlemen, I am going to ask a question or two here. To the extent you can provide a response in this open hearing, I would appreciate it very much. To the extent that you need to reflect on the question and make study of the documents, that is understood, and provide the committee for the open record a further response. But this question of accountability will be probed by the committee as we go ahead with our oversight responsibilities.

I draw your attention to the following. First is page 47 of the final report of the independent panel referred to as the Schlesinger-Harold Brown panel, and then I am going to refer to page 24 of the Kern-Jones report. This is interesting as I look at how these two conscientious groups, in working through the difficulty of trying to determine some initial observations on accountability, use different words.

In the Schlesinger report, there is a consistent use of the word "failed." For example, General Wojdakowski, CJTF-7 Deputy Commander, failed to initiate action to request additional military police for detention operations after it became clear that there were insufficient assets in Iraq. The second relates to General Fast. I have already read that into the record. The third, CJTF-7 staff judge advocate failed to initiate an appropriate response to the November 2003 ICRC report on the conditions at Abu Ghraib.

Now, you use different language, and I will go back to the Kern-Jones report. But you very carefully, General Kern, in some of your previous comments and according to my notes here, used the word that certain officers did not exercise proper responsibility. Some

were culpable. No one thus far has gone down to the other definition in the Uniform Code, "dereliction of duty."

But somehow this committee and others examining this material have to reconcile where "failed" falls in terms of your judgment as to whether or not certain individuals should be further scrutinized under the UCMJ for their actions. For example, let us talk about General Wojdakowski. Have you recommended that he be further scrutinized under the appropriate procedures of the UCMJ for those failures as indicated in the Schlesinger report? I will come back to the Jones comments later. I will ask you, General, and then you can designate your subordinates to answer the question if you so desire.

General KERN. Our analysis looked at it from the legal determination of what was "culpable" and therefore could be brought to any UCMJ action versus responsibility as a staff or commander's action, and that is the distinction that we make in our report. We reviewed this with our legal advisors on a number of occasions to ensure that we had not overlooked people who should have been held culpable. So I believe our judgments of responsible versus culpable, where culpable could be subject then to UCMJ further action, are fairly well thought out.

But I would ask for the record that we be allowed to go back because we have not made the comparison, other than the judgments we just made here earlier, on how that is reflected in the Schlesinger report in part because we do not know all the background material the Schlesinger-Brown independent panel had versus what our material was.

Chairman WARNER. I am certain that material would be available to you.

General KERN. I believe that is right.

Chairman WARNER. I will make certain that it is. I believe, gentlemen, that given your charge from the Secretary of Defense and others that you should go back and examine the documentation that led to the use of the word "failure." To me, failure measures up to culpability. Now, there may be some legal distinctions here which I will pursue, but I think they equate. Determine in your judgment whether General Wojdakowski should be further scrutinized under the UCMJ for his actions, as described by a failure in the Schlesinger panel, and why you did not make any specific reference to General Wojdakowski in your report? I am reading from page 24. You did have the following findings: "I find that the chain of command above the MI Brigade was not directly involved in any of the abuses that occurred at Abu Ghraib." Now, that finding would reflect on General Wojdakowski's actions, would it not?

General KERN. Yes.

Chairman WARNER. So at that point, he was not directly involved.

Then you go to the next one, B: "I find that the chain of command above," again General Wojdakowski, "promulgated policy memoranda that inadvertently left room for interpretation and may have indirectly led to some of the non-violent and non-sexual abuse incidents."

So I would like to have you examine again General Wojdakowski in relation to the findings of the Schlesinger commission and deter-

mine whether that is consistent with your finding here that it was simply an inadvertence. Do I make myself clear?

General KERN. Yes, Senator.

Chairman WARNER. Then you go down to the third one. "I find that Lieutenant General Sanchez and his DCG Major General Wojdakowski failed," now the word "failed" comes in—"to ensure proper staff oversight of detention and interrogation operations."

Now, you have responded very carefully and I commend you for the manner in which you addressed General Sanchez. I certainly concur, in your observations, that his overall discharge of his duty certainly is exemplary. But you do charge him with failures to ensure proper staff oversight of detention. Does that then merit any further examination under the UCMJ? It refers also to General Wojdakowski. Should he then, based on that finding, in your judgment be further scrutinized under the provisions of the UCMJ? So I ask you to provide the committee with those findings.

General KERN. Mr. Chairman, as I understood the first group that you laid out included General Wojdakowski, General Fast, SGA, which would have been Colonel Warren, and then General Sanchez.

Chairman WARNER. Yes.

General KERN. I would point out that role in providing our assessments is to make a recommendation to a commander as to whether or not UCMJ is followed. I cannot make that judgment, and in fact I would be improper if I did so. So I will need to make sure that what information I provide to you I get legal counsel on, that we make sure we do it in accordance with our own regulations and laws so I do not violate any of them.

Chairman WARNER. But you did say your charge from the Secretary of Defense is to make recommendations to commanders for appropriate action under the UCMJ, which means someone has to determine, based on your recommendations, whether or not to initiate or not initiate one of several procedures under the UCMJ.

General KERN. I hate to get in a debate with lawyers in front of me because I know I will lose. But I want to be very clear that our recommendation that comes out of the 15-6 investigation or in this case Procedure 15, in accordance with that, we can only recommend to the commander our findings and the severity of them. The commanders have to decide whether it is an administrative action or whether it is under UCMJ, and that is the line I am trying to be careful of that we do not violate in terms of command influence.

Chairman WARNER. I fully understand that. But you also bear in mind that Congress in its oversight responsibility has to determine whether or not these series of investigations under the executive branch, most specifically the DOD, have fully exhausted the question of accountability. You have specific findings on facts that presumably some came before you, perhaps other did not, but are in the Schlesinger report. You have to take that into consideration as you look at your recommendations.

General KERN. Mr. Chairman, I understand that and we will provide that for the record.

[The information referred to follows:]

In order to answer your questions, an additional review was conducted of the Schlesinger report. As a result of that review, it is the opinion of the appointing authority and the investigating officers that no further recommendations on their part are necessary.

In accordance with Army Regulation 20-1, paragraph 8-3, The Inspector General is conducting a thorough and candid analysis of these reports and will provide an objective assessment of potential impropriety by Army senior leaders, whether they were identified directly, or their involvement was implied. This assessment will be conducted in accordance with established and detailed Army procedures, to include a full legal review. Credible allegations of impropriety or failures in leadership will be referred to senior Army leadership for appropriate disciplinary action. The reports will be made available to the committee.

With regards to the CJTF-7 Staff Judge Advocate and other legal support, an investigating officer has been assigned by The Judge Advocate General's Corps under the provisions of Army Regulation 27-1 to determine if any standards of professional responsibility have been violated. The investigating officer will also make a recommendation as to actions that should/may be taken under article 92 of the Uniform Code of Military Justice.

Chairman WARNER. Because if there is somewhere along the line, whether it is the law or the charge by the Secretary of Defense to you or the charge by the Secretary of Defense to Schlesinger, some kind of a gap, then it is incumbent upon this committee to bring that to the attention presumably of the Secretary of Defense or the President, the Commander in Chief. Say that this has to be addressed as it relates to the question of accountability because those are three very important officers and you address it with some specificity on page 24 of your findings.

Why do you not take a question or two? I have taken a good deal of time here, Senator, and I may come back.

Senator LEVIN. Here is where I think we are in terms of the lack of personnel. We know from your report and from other reports that there was, as you put it, a severe under-resourcing at Abu Ghraib in the military police and MI units. We know that at the headquarters of CJTF-7 there was undermanning. That is part of your report as well. It is clear that when General Sanchez placed an MI brigade commander in command of force protection at Abu Ghraib, that they were not the ideal folks to engage in force protection. That was bringing in a unit which was not designed for force protection. I presume it is fair to say that that is a resource failure as well. It reflects a resource failure, and I am going to make that assumption. If you disagree with it, you can include that in your answer. But there is a whole litany here of significant undermanning. We start with that.

We know some of the reasons for that. One of the key reasons being your report's statement that there was an operational plan that envisioned a non-hostile environment. You already indicated this morning that that plan's mistake in projecting a non-hostile environment contributed to the failure to have adequate people on the ground to do what had to be done. So at least we know some of the causes, including that one, of the shortfall in troops.

Now, as to who is responsible for that erroneous plan, that is perhaps a different subject. That is an important subject. I happen to think it goes back to the whole question of whether General Shinseki was right and what the reaction was to General Shinseki's point, but I will not get into that today other than to state that is my belief.

Nonetheless, the plan was wrong because it projected a non-hostile environment and it turned out we had a very hostile environment.

The next question then is, since there was such a clear shortfall in forces and troops to do the job correctly, why did we not get a request or why was there not a request from General Sanchez for more troops? That is the question I want to ask you. Did he request more troops to do the job? We have these ratios which are incredible, without going back into them. An 8-to-1 ratio is your doctrinal ratio and this was 60-to-1 or 100-to-1, whatever it was. It was so far out of kilter it was obvious to everybody that there were massive shortfalls in personnel. Did General Sanchez request more people, and if not, why not?

General KERN. Senator, I would like to answer the question in two parts and then particularly ask General Jones, who did interview General Sanchez in some detail, and then clearly General Whitcomb, who was part of the CENTCOM operations, to add their comments.

First, when General Sanchez was given his initial mission as the CJTF-7 commander and all that description, as both you and I have gone through, his mission was to redeploy forces and to conduct stability and support operations. That was his stated mission; in addition to that, to support the CPA. General Abizaid, who was General Sanchez's immediate commander, very quickly took action shortly after the CJTF-7 was established to reverse the flow of forces, to stop it and to hold, as we have described earlier, forces in theater and to bring in additional forces as necessary.

Part of it goes back to General Jones. There was an assumption of how much the coalition forces would take a role.

Senator LEVIN. That is why there was the shortfall, but my question is, did he ask for more? Did General Sanchez ask for more troops?

General KERN. The answer is well, let me be very specific, and let General Jones answer because he conducted the interview with General Sanchez, and I do not want to put words into that.

General JONES. General Sanchez thought that he had sufficient MPs in theater at the time. He may not have had them at the right place, but he thought that the numbers of military police in theater, I think at the time he had three brigades, were sufficient to do the mission. He did see a need for people in the headquarters, intelligence personnel, and specific skill sets to allow the headquarters to execute the missions they were given. Those resources were requested through the joint manning document he submitted to CENTCOM.

Senator LEVIN. But that was not for the military police and military intelligence units at Abu Ghraib, was it, that joint manning document?

General JONES. In part it was. I think it had 169 positions for the joint interrogation and debriefing center at Abu Ghraib.

Senator LEVIN. So there were enough people in that joint manning document to handle the shortfalls at Abu Ghraib?

General JONES. To handle the military interrogators and analysts, yes, sir.

Senator LEVIN. The military police?

General JONES. I did not look at military police.

General KERN. Not in that part of it.

Senator LEVIN. Not in that part. So now, when he saw himself so dramatically short of personnel, did he ask for more?

General JONES. The manning document was 1,400 people.

Senator LEVIN. Not the manning document. I am talking about the part that is not in the manning document, the military police.

General KERN. I cannot answer the question's specifics. I would like General Whitcomb, who was part of the CENTCOM staff, if he could.

General WHITCOMB. Sir, I do not recall specifically if General Sanchez asked for military policemen for Abu Ghraib. I do know that General Abizaid spent quite a lot of time in Iraq with General Sanchez. They reviewed the force structure on a regular basis in terms of what was enough, specific types of forces that were required. At some point we did recognize, and I do not know whether it was late summer or the fall, but we had our military police forces, which are a low density, not many numbers, in high demand. Everybody needs them for the type of insurgency that we were seeing, that we need military police type units for convoy security, security in cities, and a number of traditional military—

Senator LEVIN. You do not know of any specific requests from General Sanchez for more troops.

General WHITCOMB. For Abu Ghraib MPs, I do not, sir.

Senator LEVIN. All right. Now, the report of the independent panel, the so-called Schlesinger Panel, says that first of all there was a time when CENTCOM refused to forward a request for additional personnel. On page 50, CENTCOM would not forward it to the Joint Chiefs. So there is an example. Do you disagree with that example, General Whitcomb?

General WHITCOMB. Senator, I read that report last night and I saw that. I know of no request that was not put in the process.

Senator LEVIN. Including that one?

General WHITCOMB. Sir, I am not familiar with a particular JAG officer or lawyer.

Senator LEVIN. So you are not familiar with that one?

General WHITCOMB. No, sir.

Senator LEVIN. But here is what it says after that. It said that there is no evidence that any of the responsible officers considered any option, and this is to get more personnel, other than the response given to Brigadier General Karpinski to wear her stars, reallocate personnel among her already overstretched units. Are you familiar with that?

General KERN. That was reported by General Taguba and our assessment.

Senator LEVIN. Was she told "Wear your stars, reallocate personnel" instead of asking for more?

General TAGUBA. Sir, I am not familiar with that particular comment, but she did convey to me that she had gone up to her chain of command. At this time she is under the tactical control of CJTF-7. She requested or at least conveyed to General Wojdakowski that she was needing of personnel.

Senator LEVIN. What was the answer?

General TAGUBA. Excuse me, sir?

Senator LEVIN. What was Wojdakowski's answer?

General TAGUBA. I was not privy to what the response was.

Senator LEVIN. Did she tell you what the response was?

General TAGUBA. Yes. She said the answer was to continue to march until such time as I could get you more forces.

Senator LEVIN. Use your troops?

General TAGUBA. Yes, sir.

Senator LEVIN. Did he say he would pass along the request?

General TAGUBA. No, sir. She did not indicate that to me.

However, though, sir, I just want to make a comment that it was recognized that when the MPs were given the mission to do Abu Ghraib exclusively, that they had already been under strength. To what she reported those, her personnel status, we did not go into that, other than she said that she had requested numerous times not just personnel but material.

Senator LEVIN. This really gets to the question of Senator Graham, as to if you need additional forces, you should ask for them and not think that it will not be welcome. Whether or not that feeling existed, that a request for additional forces would not be welcome and what role that played. That is something which is a very serious question. It is addressed by implication somewhat in the Schlesinger report. It is not really addressed in your report.

General KERN. Senator, I think what we both state and we both agree, there are insufficient military police and MI for the missions at hand because not only were these military policemen being asked to secure detention facilities, they were also conducting road security operations and many other security operations. The Army has felt for a number of years now that we have been short military police and are converting artillery units to military police as quickly as possible.

Senator LEVIN. The issue that needs to be addressed, though, is the one I raise as to why there was no additional request for those police, and there is no answer in your report. It is essential we find out whether it was because someone thought wrongly they had enough troops or because they thought a request would not be welcome, which is what the Schlesinger Panel suggests happened, relative to the Karpinski request.

General KERN. I think, as General Jones reported, the initial assessment, and I cannot tell you whether it was the final assessment or not, was that there were enough, if they had been reallocated within theater because, remember, we were collapsing the number of detention facilities and trying to consolidate. But at the same time that that happened, the number of detainees started growing. So you had two opposing issues and exactly how that assessment was presented to General Sanchez is not clear.

Senator LEVIN. Thank you.

General JONES. If I may add, that is exactly right. In May 2003, there were certain units that had already been mobilized who were demobilized because we were reversing and drawing down the troop strength.

The other thing that was dysfunctional was the tactical control relationship to CJTF-7 of the 800th MP Brigade. So their logistics and support chain was back through the 377th back in Kuwait where there is not an adequate individual replacement system. The

MP brigade was losing people going back to the States all the time and there was an insufficient individual replacement system set up.

Senator LEVIN. Thank you.

General WHITCOMB. Senator, if I may, Mr. Chairman. Just to add, hearing a lot of conversations with General Abizaid and his component commanders, his statement from the time he took command was very clear. If you need another ship, airplane, soldier, or marine, do not hesitate to ask and we will go up. So there was not any command pressure from the CENTCOM commander to not ask for forces, and that carried down through the Central Command staff also.

Senator LEVIN. Thank you.

Chairman WARNER. Senator Sessions.

Senator SESSIONS. Alabama had three MP companies in the Baghdad area, and one, the 1165th, was extended for an extra 90 days more than they expected to be there. We frankly did not have as many MPs in our system as we needed as we configured our military today. I think we will have more in the future when we continue our transformational process. So I do not think there is any doubt about that.

But, General Fay, from your review or, General Taguba, if you would like to comment, normally a shortage of personnel would result in such things as failure to feed prisoners sufficiently, exercise them, poor conditions, maybe inability to maintain discipline and put down a revolt or something like that. I do not see being short of personnel, the ideal number we would like to have had for them to have there, could be a justification for guards taking their time that presumably was short to take people out of the prisons and abuse them. Would you agree with that?

General FAY. Certainly there is no justification for ever doing any sort of prisoner abuse no matter what the numbers ratios are, sir.

Senator SESSIONS. I just would say I think if we have too few MPs in a prison, you can have things like failure to really take care of the prisoners, failure to maintain discipline, put our guards at risk because they do not have enough strength there, but I do not think that should be a basis to justify this kind of action.

I think I would ask this, General Kern, just to reiterate your analysis and review of all of these reports, has there been any policy statement or document that would have advocated policies such as the abusive policies that we have seen in photographs in these internment operations, or did the soldiers who carried out these abusive acts know they were in violation of military standards in your opinion?

General KERN. I think we found cases that we have reported that reflect all of those circumstances. There were policy directives that resulted in techniques to be used not in Iraq that found their way in there. There were misinterpretations of policy, as we reported earlier, with respect to how dogs were to be used that turned into an abuse but was clearly not directed that way. Then finally, we found soldiers who thought that they had approval to do something, interview a naked detainee. When asked about it afterward, was that a violation of the Geneva Conventions, and they said,

“Well, yes, I guess it was.” So that was a failure for their system there for them to interpret, in fact, that they were creating a violation.

Senator SESSIONS. So some of them could have thought some of the techniques that they were doing were legitimate in your view. Is that what you are saying?

General KERN. In our view, in fact, we found cases where they thought they had an approval to do something that was an abuse.

Senator SESSIONS. But the kind of abuses we saw in the photographs, you found nothing that would have justified that kind of action.

General KERN. Absolutely nothing.

The abuses in the photographs are a very different set of issues from the abuses that we are reporting here. I will ask General Fay because he went through those photographs in detail trying to identify each individual against the personnel that we have identified in our reports. Those cases were willful misconduct in our view on the part of the individuals. There was at least one case where we identified a picture and a photograph which corresponds to one of the abuses that we have reported. But the vast majority of everything that you have seen in the photographs was just misconduct not in accordance if anybody had followed the doctrine.

Senator SESSIONS. But if you read the doctrines and if you read the policies and you read them carefully and followed them strictly, it would not have justified a muzzled dog in interrogation, would it? I mean, that was something possible in Guantanamo.

General KERN. It is not even possible in Guantanamo.

Senator SESSIONS. Is that right?

General KERN. That is right, Senator.

Senator SESSIONS. But some of these things may have worked their way through some way into the system, but technically speaking, no authorization for those abuses, no actions outside the Geneva Conventions were authorized?

General KERN. We found continuously, when we asked the question, did you know that the Geneva Conventions apply to everything that you were doing in Iraq with respect to detainees, the answer came back, “Yes, we understood that.” Did they understand what that really meant in terms of the actions that they took? It was either a willful misconduct of disobeying that or a few cases that we reported where they just thought they had an approval but did not.

I would ask General Fay because he really, I think, has some of the details that would help.

General FAY. Yes, sir. First, I just want to make sure we are clear as regards to the dogs issues, because Colonel Pappas did believe he had the authority to use muzzled dogs and was granting that authority. So therefore the soldiers that were using muzzled dogs were doing it, we considered it an abuse, but they thought they were doing things appropriately.

Senator SESSIONS. Was there any instance of dogs actually being allowed to maul or bite a prisoner?

General FAY. There were actually some bitings that occurred. That was not part of an interrogation process, but a number of the 44 instances we go through, there was one instance, maybe two.

Senator SESSIONS. In the prison?

General FAY. In the prison, and there actually are pictures of the detainee after he was bitten by the dog. But that was not relating to the interrogation process.

There is one set of photos that we believe was part of the softening up process where MI was encouraging MPs to use the dogs to soften up a particular detainee who was a high-value detainee.

Senator SESSIONS. Police officers use dogs, and if a person resists arrest or something, they are authorized to allow the dog to either threaten or even attack, if they feel threatened. You can use dogs in prisons for legitimate prison activities to protect guards so you do not have to shoot perhaps a prisoner. There might be an alternative of letting a dog keep the person back rather than deadly force.

General FAY. Yes, sir, and that is the way they are used in Guantanamo, and that is what General Miller was referring to in his conversations that he had with Colonel Pappas and with others in Iraq. Dogs are currently being used in Abu Ghraib even today, but for the reasons and the methodologies that you outlined, not for the incorrect use, which is to use them in the interrogation process.

Senator SESSIONS. I salute you for maintaining discipline and reasserting the fundamental values that America adheres to. We know that mistakes occur. I think you have gone beyond—frankly, I hate this taking so much time and effort, but you have accomplished a lot and we thank you for it.

Chairman WARNER. Thank you, Senator.

Senator Reed.

Senator REED. Thank you, Mr. Chairman.

General Jones, let me follow up. I want to make sure I heard you correctly. You indicated that General Fast was aware of the death of detainee 28?

General JONES. I am not sure which number it is. She was informed of the November 4 case of the detainees brought in. She was called and informed of that death and she reported directly to General Sanchez that it had happened.

Senator REED. So as of November 4, General Sanchez was aware that there were significant violations, the death of a detainee. Is that correct?

General JONES. She was aware of the death of the detainee and she followed up, as General Sanchez directed, to go to the chief of station and ensure that an investigation was initiated.

Senator REED. Is there not a responsibility, since the death was in the custody of the United States Army, to do something more than that?

General JONES. The CID took that on.

Senator REED. Was informed?

General JONES. I think the results of that just came out recently.

Senator REED. You also indicated, General Kern, that General Fast also worked for the CPA. Is that correct?

General KERN. She supported the CPA. A considerable amount of her time was spent supporting the CPA.

Senator REED. So she essentially had, if not formally, informally two commanders, Ambassador Bremer and General Sanchez, maybe not in the strict formal sense.

General KERN. Formally, she had one commander. Informally, she was reporting to two different headquarters, yes.

Senator REED. You have not had an opportunity to interview Ambassador Bremer or other CPA officials?

General KERN. That is correct, Senator.

Senator REED. So it is conceivable that she was receiving instructions from Ambassador Bremer and the CPA that were different or inconsistent from instructions she received from General Sanchez?

General KERN. It is conceivable, but it never came out in any of our interviews that that is the case.

General FAY. I do not believe it is conceivable, sir. I spent a great deal of time with General Fast on two occasions, and I believe, through all my questioning, she would have revealed that to me if that were the case.

General JONES. General Sanchez—

Senator REED. Excuse me. Did you ask her specifically if she received guidance from anyone else?

General FAY. I did not, sir.

Senator REED. You did not. So that is a conjecture on your part.

General FAY. It is, sir.

Senator REED. General Jones?

General JONES. I specifically asked General Sanchez if he got direction from Mr. Bremer, and he said occasionally he would ask us to do things. If any of his guidance or requests conflicted with the guidance he got from the CENTCOM commander, he would go back to the CENTCOM commander to clarify the—

Senator REED. That is General Abizaid?

General JONES. Yes, sir.

Senator REED. With respect to the information that Colonel Warren had with potential violations of the Geneva Conventions, as you cite in the report, how long did he wait before informing General Sanchez of the possible violations of the Geneva Conventions?

General KERN. In my view General Sanchez was not informed until after the atrocities came out. The person that he informed was General Karpinski. Let me make sure I have that correct from General Taguba because that was the part that he followed.

General TAGUBA. Yes, sir. The trail was the serving battalion commander, an acting battalion commander at Abu Ghraib was at an out-brief by ICRC in October, which was in General Karpinski's chain of command.

Chairman WARNER. Let us put his name in the record.

General TAGUBA. Yes, sir. It is Lieutenant Colonel Chew, C-h-e-w.

Senator REED. Let me try to understand this. Colonel Warren is the staff judge advocate for General Sanchez.

General KERN. CJTF-7, correct.

Senator REED. He is the staff judge advocate. He has been informed that there are serious violations potentially of the Geneva Conventions. He is the chief legal officer in theater. He is responsible more than anyone else on a staff level to ensure that these

laws are interpreted correctly and followed. He received that notification, roughly when would that be? Does anyone know?

General KERN. It was November I think.

General JONES. He was on leave from November 8 or 12 to the end of November, his mid-tour leave. He came back and the ICRC report had been worked by his staff, and they had prepared a response for General Karpinski. It is that time, early December, that he saw it.

Senator REED. Now, he was not notified while on leave of this development? This was done at a staff level by a deputy?

General JONES. Not that I am aware of.

Senator REED. The officer assigned to investigate these charges, at least to validate them, and prepare a letter was Major O'Kane of the Australian Army. Is that correct?

General KERN. He was at least one of the people involved.

Senator REED. He apparently, from the report, actually drafted the response that General Karpinski said she signed without any specific knowledge. Is that accurate?

General FAY. Yes. I believe it was Major O'Kane from the Australian Army that actually went to Abu Ghraib.

Senator REED. Major O'Kane has refused to make himself available to any questioning by this panel. Is that correct?

General FAY. I am not sure that is technically correct. We made our request through the Australian government. I am not sure whether the lack of a response to produce Major O'Kane was his decision or the Australian government's decision. They did respond in writing very recently to some written questions we submitted to Major O'Kane.

Senator REED. But a key witness, if you will, to the incidents of the ICRC report, who knew what within the JAG section, whether Colonel Warren was fully apprised of it, when General Sanchez was apprised, has been beyond the scope of your investigation. You have not reached him.

General FAY. That is correct, sir.

Senator REED. But the situation which troubles me, frankly, is you have the key staff officer responsible for informing the commander of the operation of the Geneva Conventions, respect for it, and that person has information, credible information, which he withholds. Again, I will re-ask the question. I did not get an answer. When did he finally indicate to General Sanchez that this had been going on? How many weeks or months?

General KERN. I would have to go back and check for a specific date, but I believe the answer is January, which would have been about a month after he knew of it.

Senator REED. He knew it for a month, and his revelation to the General was contemporaneous with the photographs coming to light. Is that correct?

General KERN. That is our knowledge, yes, Senator.

Senator REED. That is correct. To me, that is a gross disservice to General Sanchez as the Commander. Yet, this report concludes, General Jones, that the staff of CJTF-7 did everything reasonably they could do. I beg to disagree. I respect your position, but I beg to disagree. I think the obligation of that officer was to inform his commander immediately. Maybe these suspicions were unfounded,

but then to investigate fully. Apparently the investigating officer has gone to Australia and has not cooperated with any degree. I think that is a glaring omission in this report.

General KERN. Senator, I think what we conclude in the report is that the whole method of receiving and processing the ICRC reports is inadequate and it needs an independent person involved. Our suggestion is that it ought to be somebody in the Inspector General chain of command who would take that report, not somebody in the staff process.

Senator REED. General, I respect that and that is a good recommendation. But it still does not answer the question why in terms of your recommendations, you have not indicated that it was a glaring error from the staff of this combined task force to inform their commander. Then there is another dimension, which is the UCMJ, which General Fay cites in his report very accurately the responsibility to report that officially as a crime.

This raises to me in my mind two very important questions. First, the question of the scope of this investigation. Are you applying the same standard of justice and accountability to low ranking officers as you are to higher ranking officers?

General KERN. In our judgment, we are and I would expect that you would hold us to that standard as well. That is why we clearly went through and did the reviews of what we define as culpability versus responsibility. We have had a number of discussions with our legal staffs about where that line is. Now, Senator Warner has asked us to relook that in the light of the recommendations made with the Schlesinger report, and we will do that and relook those recommendations.

Senator REED. I appreciate it.

Chairman WARNER. I think the line of questioning by our colleague merits, with regard to this particular colonel, that similarly should be examined in that light.

General KERN. He was one that I included in that list.

Senator REED. Yes, and he is in here.

General JONES. I have not seen the ICRC report, whether or not it specifically referred to instances that could be categorized as abusive. I think the responsibility, I agree with you, to inform the commander if the substance of those reports were such that there were abuses was there. Now, having not seen the ICRC report and the details, they did owe an investigation also, at least an analysis, to determine if there were abuses. Or if the report of the ICRC was doing merited further investigation, and they should have done that before they informed the commander also.

Senator REED. I have seen the reports, General. My recollection is they report the prisoners were kept naked, prisoners were being held in conditions that I think the reasonable person, let alone the reasonable international lawyer, would conclude were, per se, violations or at least plausible violations.

But let me go on. There is something here too. You are making this differentiation between culpability and responsibility. I assume under the UCMJ it is the responsibility of someone who has been informed about abuses to report the violations. Apparently Colonel Warren did not report those violations to his immediate commander. Colonel Bolt, who was cited in the report, the discussion

with Colonel Pappas—and again, there is a gap in the information. But I have to believe that if I were the 06 witnessing what happened on November 4 and other incidents, that I would simply not walk in and have a technical discussion about the standard operating procedure (SOP) for the CIA. I think I would tell them this is what they are doing down there in this prison. What do I do? The message was cooperate. We are just one big team. In other words, look away.

Now, the real question that troubles me and I do not think you reached this in the report, these are all professional soldiers, highly capable people. You might disagree with some of them as being not up to the standards of a general officer or a colonel or a captain, but I have met General Fast. I share your judgment. She is a superb professional. I think General Wojdakowski would not be the Deputy Commander unless he similarly had those skills. Colonel Warren was here testifying. He impressed all of us as a remarkably intelligent and dedicated officer, not only a professional soldier but a lawyer.

Why would all these people not follow Army regulations, not report violations of the Geneva Conventions, wait months to inform commanders of vital information, and then take action which was designed not to report these violations, but simply to try to fix them going through the CIA?

There are many answers I have. One, is that they were told to do that. I do not think they were told that by General Sanchez because frankly, it appears to me based on the report, General Sanchez was kept in the dark. But somebody I think suggested that these people should not do what professional soldiers should do.

I am looking at all of you gentlemen. I think if you found out that your staff officers, your subordinates were doing this, it would not take a year of investigations. They would be fired immediately and charged with dereliction of duty, particularly if you found out if they were hiding information from you.

I do not think you have reached that, to me, basic question of what went on out there. I appreciate what you have done. I appreciate your service to the country and to the Army.

Chairman WARNER. Thank you. Let us give the panel an opportunity to reply to the Senator's observation. He may not have couched it in a direct question but the chair gives you such opportunity as you and your colleagues wish.

General KERN. Senator Reed, I think we are troubled by the same issues that you raise, and in our review of it, our judgment was to hold these people responsible for their staff actions but not culpable for criminal actions. That was the judgment which we reached in looking at it. If there is additional information, as you suggested that there may be, that is a different circumstance than what we found in our investigation.

I take very seriously and I think every member of this panel takes very seriously that we hold all ourselves to the same standard. We looked at this very seriously. There was a great deal of review by multiple personnel, to include lawyers, and the judgment we made is the one of responsibility. The people that you referred to all acknowledge that they should have done more. The line that

we drew was whether or not they were in a position to have prevented, taken part, condoned, or participated in an abuse, and that is the distinction that we worked through from a legal standpoint.

The issue that you bring up of dereliction of duty, we report as where they failed in their responsibilities and their staff action. That report has been provided to their chains of command, the same as we provided it to you. So they have the same information to deal with as you and I do.

We are taking on also, to further avail ourselves of the information which the Schlesinger panel may have found, which may provide different information and get back to your committee in response to whether or not our judgments would have a different outcome if we considered that information.

I would clearly ask my other panel members to comment.

General JONES. I would agree, sir, and I appreciate your logic and how you are seeing what we have reported. I think that same logic has to be applied by the commanders in the chain of command, the people we have given the report to. Certainly if there was knowledge, it should have been reported. The issue becomes how much knowledge did they have and to ascertain that level of knowledge and what actions they did take. There are instances, outside of the ICRC report in terms of the CID and other investigations that were reported. They did have a method to track it, and they did keep the commander informed. So it is an issue of which abuses and knowledge level of abuses, and they applied their military experience to tell that commander. Certainly in some cases they should have.

I will tell you in other cases they told the commander right away and investigations were initiated and it was done properly. There were instances that dealt with the agency that were handled very quickly and to get a response to make sure they complied with the rules and the policies in place.

Senator REED. Thank you, gentlemen.

Chairman WARNER. Thank you.

The revelation by our distinguished colleague about this Australian officer, that he is somehow at the moment beyond your ability to interrogate, it seems to me you ought to consider sending someone from the judge advocate staff out there to take his deposition under oath. I would assume the government of Australia would agree to that because I think that is an integral piece of evidence here as to the timing and the circumstances under which the staff judge advocate to General Sanchez had knowledge.

General FAY. Sir, just so you understand, we did ask for that.

Chairman WARNER. Did you?

General FAY. Yes, and all that we were provided was that they would agree to have us submit questions in writing and for him to give the answers in writing. In fact, we only got those answers 2 weeks ago.

Chairman WARNER. Did they bear on this issue with any detail in your judgment?

General FAY. No. They were insufficient to answer the questions being raised today. It really would be much more beneficial if we were able to question the gentleman directly.

Chairman WARNER. I personally agree with my colleague here, to intervene, if necessary, with the Australian government, but I would like first to have the Secretary of Defense review what his options are to back up the work of this panel.

Senator LEVIN. Just one last question on the Secretary of Defense, if I may. It has to do with the fact they apparently approved Tenet's request to keep a CIA detainee at a military detention facility in Iraq without informing the ICRC of that presence. Did you talk to the Secretary of Defense about that approval? Did it take place and whether that approval, if it occurred, relates to the presence of the ghost detainees at Abu Ghraib?

General KERN. Sir, we did not ask him about that. It did not occur at Abu Ghraib.

Senator LEVIN. No, but could it relate to—

General KERN. —it could relate, yes.

Senator LEVIN. Should he not be asked then about why he did that, and should you not tell us in a report whether or not that decision on his part to approve that, which is a violation of the Geneva Conventions, whether that in some way is related also to the presence of ghost detainees at Abu Ghraib?

General KERN. Sir, there are enough unknown questions about the ghost detainees and what agreements were made with whom. It is why we asked, per the directions that we have, for the DOD Inspector General and the CIA Inspector General to take it on.

Senator LEVIN. I think we ought to be informed of that. I think it is an important part of the ghost detainee issue.

Thank you, Mr. Chairman.

Chairman WARNER. Gentlemen, we compliment you once again for a very thorough job, and I thank you for taking on the added responsibility to try and reply to several questions.

Senator LEVIN. I think we are all grateful.

Chairman WARNER. The record will remain open through the close of business tomorrow night for such other questions that might be promulgated by members of the panel to you.

Thank you again very much. You have done a great service to the country, to the DOD, and to your Army which you have given so much of your life, together with your families. We are adjourned.

[The report "Investigation of Intelligence Activities at Abu Ghraib" follows:]

EXECUTIVE SUMMARY

Investigation of Intelligence Activities**At
Abu Ghraib****Background**

This investigation was ordered initially by LTG Ricardo S. Sanchez, Commander, Combined Joint Task Force Seven (CJTF-7). LTG Sanchez appointed MG George R. Fay as investigating officer under the provisions of Army Regulation 381-10, Procedure 15. MG Fay was appointed to investigate allegations that members of the 205th Military Intelligence Brigade (205 MI BDE) were involved in detainee abuse at the Abu Ghraib Detention Facility. Specifically, MG Fay was to determine whether 205 MI BDE personnel requested, encouraged, condoned, or solicited Military Police (MP) personnel to abuse detainees and whether MI personnel comported with established interrogation procedures and applicable laws and regulations.

On 16 June 2004, Acting Secretary of the Army R. L. Brownlee appointed General Paul J. Kern, Commander, US Army Materiel Command (AMC), as the new Procedure 15 appointing authority. On 25 June 2004, GEN Kern appointed LTG Anthony R. Jones, Deputy Commanding General, US Army Training and Doctrine Command, as an additional Procedure 15 investigating officer. MG Fay was retained as an investigating officer.

Without reinvestigating areas reviewed by MG Fay, LTG Jones was specifically directed to focus on whether organizations or personnel higher than the 205th MI BDE chain of command, or events and circumstances outside of the 205th MI Brigade, were involved, directly or indirectly, in the questionable activities regarding alleged detainee abuse at Abu Ghraib prison.

The investigative teams conducted a comprehensive review of all available background documents and statements pertaining to Abu Ghraib from a wide variety of sources. These sources included the reports written by MG Geoffrey Miller, MG Donald Ryder, MG Antonio Taguba and the Department of Army Inspector General. LTG Jones interviewed LTG Sanchez and MG Barbara Fast, the CJTF-7 Senior Intelligence Staff Officer. MG Fay's team conducted over 170 interviews concerning the interviewees' knowledge of interrogation and detention operations at Abu Ghraib and/or their knowledge of and involvement in detainee abuse. MG Fay's interviews included interviews with MG Fast, MG Walter Wojdakowski, MG Geoffrey Miller, MG Thomas Miller, and BG Janis Karpinski.

Operational Environment

The events at Abu Ghraib cannot be understood in a vacuum. Three interrelated aspects of the operational environment played important roles in the abuses that occurred at Abu Ghraib. First, from the time V Corps transitioned to become CJTF-7, and throughout the period under investigation, it was not resourced adequately to accomplish the missions of the CJTF: stability and support operations (SASO) and support to the Coalition Provisional Authority (CPA). The CJTF-7 headquarters lacked adequate personnel and equipment. In addition, the military police and military intelligence units at Abu Ghraib were severely under-resourced. Second, providing support to the Coalition Provisional Authority (CPA) required greater resources than envisioned in operational plans. Third, operational plans envisioned that CJTF-7 would execute SASO and provide support to the CPA in a relatively non-hostile environment. In fact, opposition was robust and hostilities continued throughout the period under investigation. Therefore, CJTF-7 had to conduct tactical counter-insurgency operations, while also executing its planned missions.

These three circumstances delayed establishment of an intelligence architecture and degraded the ability of the CJTF-7 staff to execute its assigned tasks, including oversight of interrogation and detention operations at Abu Ghraib.

When hostilities were declared over, US forces had control of only 600 Enemy Prisoners of War (EPW) and Iraqi criminals. In the fall of 2003, the number of detainees rose exponentially due to tactical operations to capture counter-insurgents dangerous to U.S. forces and Iraqi civilians. At that time, the CJTF-7 commander believed he had no choice but to use Abu Ghraib as the central detention facility.

Command and staff actions and inaction must be understood in the context of the operational environment discussed above. In light of the operational environment, and CJTF-7 staff and subordinate unit's under-resourcing and increased missions, the CJTF-7 Commander had to prioritize efforts. CJTF-7 devoted its resources to fighting the counter-insurgency and supporting the CPA, thereby saving Coalition and civilian Iraqi lives and assisting in the transition to Iraqi self-rule. In the over-all scheme of OIF, the CJTF-7 Commander and staff performed above expectations.

Abuse

Clearly abuses occurred at the prison at Abu Ghraib. There is no single, simple explanation for why this abuse at Abu Ghraib happened. The primary causes are misconduct (ranging from inhumane to sadistic) by a small group of morally corrupt soldiers and civilians, a lack of discipline on the part of the leaders and Soldiers of the 205th MI BDE and a failure or lack of leadership by multiple echelons within CJTF-7. Contributing factors can be traced to issues affecting Command and Control, Doctrine, Training, and the experience of the Soldiers we asked to perform this vital mission.

For purposes of this report, abuse is defined as treatment of detainees that violated U.S. criminal law or international law or treatment that was inhumane or coercive without lawful justification. Whether the Soldier or contractor knew, at the time of the acts, that the conduct violated any law or standard, is not an element of the definition.

The abuses at Abu Ghraib primarily fall into two categories: a) intentional violent or sexual abuse and, b) abusive actions taken based on misinterpretations or confusion regarding law or policy.

LTG Jones found that while senior level officers did not commit the abuse at Abu Ghraib they did bear responsibility for lack of oversight of the facility, failing to respond in a timely manner to the reports from the International Committee of the Red Cross and for issuing policy memos that failed to provide clear, consistent guidance for execution at the tactical level.

MG Fay has found that from 25 July 2003 to 6 February 2004, twenty-seven 205 MI BDE Personnel allegedly requested, encouraged, condoned or solicited Military Police (MP) personnel to abuse detainees and/or participated in detainee abuse and/or violated established interrogation procedures and applicable laws and regulations during interrogation operations at Abu Ghraib.

Most, though not all, of the violent or sexual abuses occurred separately from scheduled interrogations and did not focus on persons held for intelligence purposes. No policy, directive or doctrine directly or indirectly caused violent or sexual abuse. In these cases, Soldiers knew they were violating the approved techniques and procedures.

Confusion about what interrogation techniques were authorized resulted from the proliferation of guidance and information from other theaters of operation; individual interrogator experiences in other theaters; and, the failure to distinguish between interrogation operations in other theaters and Iraq. This confusion contributed to the occurrence of some of the non-violent and non-sexual abuses.

MG Taguba and MG Fay reviewed the same photographs as supplied by the US Army Criminal Investigation Command (CID). MG Fay identified one additional photograph depicting abuse by MI personnel that had not been previously identified by MG Taguba. MG Fay also identified other abuse that had not been photographed.

Alleged incidents of abuse by military personnel have been referred to the CID for criminal investigation and the chain of command for disciplinary action. Alleged incidents of abuse by civilian contractors have been referred through the Department of Defense to the Department of Justice.

Discipline and Leadership

Military Intelligence and Military Police units had missions throughout the Iraqi Theater of Operations (ITO), however, 205th MI Brigade and 800th Military Police Brigade leaders at Abu Ghraib failed to execute their assigned responsibilities. The leaders from units located at Abu Ghraib or with supervision over Soldiers and units at Abu Ghraib, failed to supervise subordinates or provide direct oversight of this important mission. These leaders failed to properly discipline their Soldiers. These leaders failed to learn from prior mistakes and failed to provide continued mission-specific training. The 205th MI Brigade Commander did not assign a specific subordinate unit to be responsible for interrogations at Abu Ghraib and did not ensure that a Military Intelligence chain of command at Abu Ghraib was established. The absence of effective leadership was a factor in not sooner discovering and taking actions to prevent both the violent/sexual abuse incidents and the misinterpretation/confusion incidents.

Neither Department of Defense nor Army doctrine caused any abuses. Abuses would not have occurred had doctrine been followed and mission training conducted. Nonetheless, certain facets of interrogation and detention operations doctrine need to be updated, refined or expanded, including, the concept, organization, and operations of a Joint Interrogation and Debriefing Center (JIDC); guidance for interrogation techniques at both tactical and strategic levels; the roles, responsibilities and relationships between Military Police and Military Intelligence personnel at detention facilities; and, the establishment and organization of a Joint Task Force structure and, in particular, its intelligence architecture.

Other Contributing Factors

Demands on the Human Intelligence (HUMINT) capabilities in a counter-insurgency and in the future joint operational environment will continue to tax tactical and strategic assets. The Army needs trained and experienced tactical HUMINT personnel.

Working alongside non-DOD organizations/agencies in detention facilities proved complex and demanding. The perception that non-DOD agencies had different rules regarding interrogation and detention operations was evident. Interrogation and detention policies and limits of authority should apply equally to all agencies in the Iraqi Theater of Operations.

"Ghost Detainees"

The appointing authority and investigating officers made a specific finding regarding the issue of "ghost detainees" within Abu Ghraib. It is clear that the interrogation practices of other government agencies led to a loss of accountability at Abu Ghraib. DoD must document and enforce adherence by other government agencies with established DoD practices and procedures while conducting detainee interrogation operations at DoD facilities. This matter requires further investigation and, in accordance

with the provisions of AR 381-10, Part 15, is being referred to the DoD Inspector General, as the DoD liaison with other government agencies for appropriate investigation and evaluation. Soldiers/Sailors/Airmen/Marines should never be put in a position that potentially puts them at risk for non-compliance with the Geneva Convention or Laws of Land Warfare.

Conclusion

Leaders and Soldiers throughout Operation Iraqi Freedom were confronted with a complex and dangerous operational environment. Although a clear breakdown in discipline and leadership, the events at Abu Ghraib should not blind us from the noble conduct of the vast majority of our Soldiers. We are a values based profession in which the clear majority of our Soldiers and leaders take great pride.

A clear vote of confidence should be extended by the senior leadership to the leaders and Soldiers who continue to perform extraordinarily in supporting our Nation's wartime mission. Many of our Soldiers have paid the ultimate sacrifice to preserve the freedoms and liberties that America and our Army represent throughout the world.

23 August 2004

1121

UNCLASSIFIED

**AR 15-6 Investigation
of the Abu Ghraib Prison
and 205th Military Intelligence Brigade**

LTG Anthony R. Jones

UNCLASSIFIED

1122

UNCLASSIFIED

**AR 15-6 Investigation of the
Abu Ghraib Detention Facility
and 205th MI Brigade**

LTG Anthony R. Jones

(U) Table of Contents

1. (U) Executive Summary	3
2. (U) Charter and Investigative Activity	7
3. (U) Background: Operation Iraqi Freedom during this Period	7
4. (U) Operational Environment	8
5. (U) Assessments and Visits to Improve Intelligence, Detention and Interrogation Operations	11
6. (U) Indications and Warnings	12
7. (U) Doctrine, Organizational Structure and Policy Challenges in the Iraqi Theater of Operations	13
8. (U) Specific Comments on Abuse at Abu Ghraib	15
9. (U) Assessments as the Senior Investigating Officer	18
10. (U) Concluding Findings and Recommendations	24

UNCLASSIFIED

UNCLASSIFIED

**(U) AR 15-6 Investigation of the
Abu Ghraib Detention Facility
and 205th MI Brigade**

1. (U) Executive Summary

a. (U) Appointment, Charter and Investigative Activity

(1) (U) On 24 June 2004, Acting Secretary of the Army R. L. Brownlee notified me that I was selected to serve as the Senior Investigating Officer in the investigation of the 205th Military Intelligence Brigade. GEN Paul Kern was the appointing authority and in a memorandum, dated 25 June 2004, formally designated me Senior Investigating Officer. MG George Fay, who had been investigating the 205th MI BDE since his appointment by LTG Ricardo Sanchez on 31 March 2004, would continue as an investigating officer. Without reinvestigating areas reviewed by MG Fay, I was specifically directed to focus on whether organizations or personnel higher than the 205th Military Intelligence (MI) Brigade chain of command, or events and circumstances outside of the 205th MI Brigade, were involved, directly or indirectly, in the questionable activities regarding alleged detainee abuse at Abu Ghraib prison.

(2) (U) During the course of my investigation, I interviewed LTG Ricardo Sanchez, the Commander of Combined Joint Task Force-7 (CJTF-7)¹ during the period under investigation, and the senior intelligence officer on his staff, MG Barbara Fast (the "C2"). In addition, I reviewed witness statements that MG Fay's investigation team had collected; assessment and investigation reports written by MG Geoffrey Miller, MG Donald Ryder, MG Antonio Taguba and the Department of the Army Inspector General (DAIG); and other written materials including relevant law, doctrine, organizational documents, policy, directives, and U.S. Central Command (CENTCOM) and CJTF-7 operational orders (OPORDS) and fragmentary orders (FRAGOs).

b. (U) Background and Operational Environment

(1) (U) The events at Abu Ghraib cannot be understood in a vacuum. Three interrelated aspects of the operational environment played important roles in the abuses that occurred at Abu Ghraib. First, from the time V Corps transitioned to become CJTF-7, and throughout the period under investigation, it was not resourced adequately to accomplish the missions of the CJTF: stability and support operations (SASO) and support to the Coalition Provisional Authority (CPA). The CJTF-7 headquarters lacked adequate personnel and equipment. In addition, the military police and military intelligence units at Abu Ghraib were severely under-resourced. Second, providing support to the Coalition Provisional Authority (CPA) required greater resources than envisioned in operational plans. Third, operational plans envisioned that CJTF-7 would execute SASO and provide support to the CPA in a relatively non-hostile environment. In fact, opposition was robust and hostilities continued throughout the period under investigation. Therefore, CJTF-7 had to conduct tactical counter-insurgency operations, while also executing its planned missions.

¹ CJTF-7 was the higher headquarters to which the 205th MI Brigade reported.

UNCLASSIFIED

UNCLASSIFIED

(2) (U) These three circumstances delayed establishment of an intelligence architecture and degraded the ability of the CJTF-7 staff to execute its assigned tasks, including oversight of interrogation and detention operations at Abu Ghraib.

(3) (U) When hostilities were declared over, U.S. forces had control of only 600 Enemy Prisoners of War (EPWs) and Iraqi criminals. In the fall of 2003, the number of detainees rose exponentially due to tactical operations to capture counter-insurgents dangerous to U.S. forces and Iraqi civilians. At this time, the CJTF-7 commander believed he had no choice but to use Abu Ghraib as the central detention facility.

c. (U) Abuse at Abu Ghraib

(1) (U) Clearly abuses occurred at the prison at Abu Ghraib. For purposes of this report, I defined abuse as treatment of detainees that violated U.S. criminal law or international law or treatment that was inhumane or coercive without lawful justification. Whether the Soldier or contractor knew, at the time of the acts, that the conduct violated any law or standard, is not an element of the definition. MG Fay's portion of this report describes the particular abuses in detail.

(2) (U) I found that no single, or simple, explanation exists for why some of the Abu Ghraib abuses occurred. For clarity of analysis, my assessment divides abuses at Abu Ghraib into two different types of improper conduct: First, intentional violent or sexual abuses and, second, actions taken based on misinterpretations of or confusion about law or policy.

(3) (U) Intentional violent or sexual abuses include acts causing bodily harm using unlawful force as well as sexual offenses including, but not limited to rape, sodomy and indecent assault. No Soldier or contractor believed that these abuses were permitted by any policy or guidance. If proven, these actions would be criminal acts. The primary causes of the violent and sexual abuses were relatively straight-forward - individual criminal misconduct, clearly in violation of law, policy, and doctrine and contrary to Army values.

(4) (U) Incidents in the second category resulted from misinterpretations of law or policy or resulted from confusion about what interrogation techniques were permitted. These latter abuses include some cases of clothing removal (without any touching) and some uses of dogs in interrogations (uses without physical contact or extreme fear). Some of these incidents may have violated international law. At the time the Soldiers or contractors committed the acts, however, some of them may have honestly believed the techniques were condoned.

d. (U) Major Findings

(1) (U) The chain of command directly above the 205th MI Brigade was not directly involved in the abuses at Abu Ghraib. However, policy memoranda promulgated by the CJTF-7 Commander led indirectly to some of the non-violent and non-sexual abuses. In addition, the CJTF-7 Commander and Deputy Commander failed to ensure proper staff oversight of detention and interrogation operations. Finally, CJTF-7 staff elements reacted inadequately to earlier indications and warnings that problems existed at Abu Ghraib.

UNCLASSIFIED

UNCLASSIFIED

Command and staff actions and inaction must be understood in the context of the operational environment discussed above. In light of the operational environment, and CJTF-7 staff and subordinate unit's under-resourcing and increased missions, the CJTF-7 Commander had to prioritize efforts. CJTF-7 devoted its resources to fighting the counter-insurgency and supporting the CPA, thereby saving Coalition and civilian Iraqi lives and assisting in the transition to Iraqi self-rule. I find that the CJTF-7 Commander and staff performed above expectations, in the over-all scheme of OIF.

(2) (U) Most, though not all, of the violent or sexual abuses occurred separately from scheduled interrogations and did not focus on persons held for intelligence purposes. No policy, directive or doctrine directly or indirectly caused violent or sexual abuse. Soldiers knew they were violating the approved techniques and procedures.

(3) (U) Confusion about what interrogation techniques were authorized resulted from the proliferation of guidance and information from other theaters of operation; individual interrogator experiences in other theaters; and, the failure to distinguish between interrogation operations in other theaters and Iraq. This confusion contributed to the occurrence of some of the non-violent and non-sexual abuses.

(4) (U) Military Intelligence and Military Police units also had missions throughout the Iraqi Theater of Operations (ITO), however, 205th MI Brigade and 800th Military Police Brigade leaders at Abu Ghraib failed to execute their assigned responsibilities. The leaders from these units located at Abu Ghraib or with supervision over Soldiers and units at Abu Ghraib, failed to supervise subordinates or provide direct oversight of this important mission. These leaders failed to properly discipline their Soldiers. These leaders failed to learn from prior mistakes and failed to provide continued mission-specific training. The 205th MI Brigade Commander did not assign a specific subordinate unit to be responsible for interrogations at Abu Ghraib and did not ensure that a Military Intelligence chain of command at Abu Ghraib was established. The absence of effective leadership was a factor in not sooner discovering and taking actions to prevent both the violent/sexual abuse incidents and the misinterpretation/confusion incidents.

(5) (U) Neither Defense nor Army doctrine caused any abuses. Abuses would not have occurred had doctrine been followed and mission training conducted. Nonetheless, certain facets of interrogation and detention operations doctrine need to be updated, refined or expanded, including, the concept, organization, and operations of a Joint Interrogation and Debriefing Center (JIDC); guidance for interrogation techniques at both tactical and strategic levels; the roles, responsibilities and relationships between Military Police and Military Intelligence personnel at detention facilities; and, the establishment and organization of a Joint Task Force structure and in particular, its intelligence architecture.

(6) (U) No single or simple theory can explain why some of the abuses at Abu Ghraib occurred. In addition to individual criminal propensities, leadership failures and, multiple policies, many other factors contributed to the abuses occurring at Abu Ghraib, including:

- Safety and security conditions at Abu Ghraib;

UNCLASSIFIED

c

UNCLASSIFIED

- Multiple agencies/organizations involvement in interrogation operations at Abu Ghraib;
- Failure to effectively screen, certify, and then integrate contractor interrogators/analysts/linguists;
- Lack of a clear understanding of MP and MI roles and responsibilities in interrogation operations.
- Dysfunctional command relationships at brigade and higher echelons, including the tactical control (TACON) relationship between the 800th MP Brigade and CJTF-7.

(7) (U) Demands on the Human Intelligence (HUMINT) capabilities in a counter-insurgency and in the future joint operational environment will continue to tax tactical and strategic assets. The Army needs trained and experienced tactical HUMINT personnel.

(8) (U) Working alongside non-DOD organizations/agencies in detention facilities proved complex and demanding. The perception that non-DOD agencies had different rules regarding interrogation and detention operations was evident, Interrogation and detention policies and limits of authority should apply equally to all agencies in the Iraqi Theater of Operations.

(9) (U) Leaders and Soldiers throughout Operation Iraqi Freedom were confronted with a complex and dangerous operational environment. Although a clear breakdown in discipline and leadership, the events at Abu Ghraib should not blind us from the noble conduct of the vast majority of our Soldiers. We are a values based profession in which the clear majority of our Soldiers and leaders take great pride.

(10) (U) A clear vote of confidence should be extended by the senior leadership to the leaders and Soldiers who continue to perform extraordinarily in supporting our Nation's wartime mission. Many of our Soldiers have paid the ultimate sacrifice to preserve the freedoms and liberties that America and our Army represent throughout the world.

UNCLASSIFIED

UNCLASSIFIED

2. (U) Charter and Investigative Activity

a. (U) On 24 June 2004, Acting Secretary of the Army, R. L. Brownlee, notified me that I was selected to serve as the Senior Investigating Officer in the investigation of the 205th Military Intelligence Brigade. GEN Paul Kern was the appointing authority and in a memorandum dated 25 June 2004, formally designated me Senior Investigating Officer. MG George Fay, who had been investigating the 205th MI BDE since his appointment by LTG Ricardo Sanchez on 31 March 2004, would continue as an investigating officer.

b. (U) My specific duties were to focus on whether organizations or personnel higher than the 205th Military Intelligence (MI) Brigade chain of command, or events and circumstances outside of the 205th MI Brigade, were involved, directly or indirectly, in the questionable activities regarding alleged detainee abuse at Abu Ghraib prison.

c. (U) In accordance with guidance from the Appointing Authority, I would interview LTG Ricardo Sanchez and other Combined Joint Task Force-7 (CJTF-7) staff, as required, to obtain information to make findings and recommendations to GEN Kern on the culpability of senior leaders who had responsibility for interrogation and detainee operations in Iraq. My directions were to not reinvestigate the areas that MG Fay had already reviewed. Rather, I was to look at operational and strategic level events that occurred prior to and during the period under investigation and determine their relationship, if any, to the abuses that occurred while the 205th MI Brigade was involved in interrogations and intelligence analysis at Abu Ghraib.

d. (U) During the course of my investigation, I interviewed LTG Ricardo Sanchez, the Commander of Combined Joint Task Force-7 (CJTF-7) during the period under investigation, and the senior intelligence officer on his staff, MG Barbara Fast (the "C2"). In addition, I reviewed witness statements that MG Fay's investigation team had collected; reviewed the assessment and investigation reports written by MG Geoffrey Miller, MG Donald Ryder, MG Antonio Taguba, and the Department of the Army Inspector General; and reviewed other written materials including relevant law, doctrine, organizational documents, policy, directives, and U.S. Central Command (CENTCOM) and CJTF-7 Operational Orders (OPORDS) and Fragmentary Orders (FRAGOs).

3. (U) Background: Operation Iraqi Freedom During this Period

UNCLASSIFIED

UNCLASSIFIED

4. (U) Operational Environment

a. (U) Before deciding to centralize detainees at Abu Ghraib, major organizational changes were ongoing in the structure of U.S. Forces fighting the Iraqi campaign. Following major ground operations and declaration of the end of hostilities, the U.S. Army V Corps transitioned to become the CJTF-7. Also during this period, then-MG Sanchez was promoted to Lieutenant General and assumed command of V Corps, replacing LTG Wallace who led Phase III, Decisive Operations, in Iraq. LTG Sanchez transitioned from commanding a division, consisting of approximately 15,000 Soldiers, to commanding V Corps. The U.S. Third Army, or ARCENT, was designated the Combined Forces Land Component Command under the U.S. Central Command during the initial phases of OW. When V Corps transitioned to the CJTF-7, the new command assumed responsibility for the Combined Forces Land Component Command (CFLCC) missions and operations in the Iraqi Theater of Operations (IT O). The Forces under the command of LTG Sanchez grew to approximately 180,000 U.S. and Coalition forces. In addition, the new CJTF-7 was directed to transition to Phase IV of the Iraqi campaign. Phase IV operations were envisioned as stability and support operations (SASO) and direct support to the CPA. CJTF-7 assistance to the CPA was essential to help the CPA succeed in recreating essential government departments under the control of Iraqi leaders. CJTF-7 would also help the CPA transition control of critical government organizations, strategic communications, reconstruction contracts, and lines of operation necessary to enable Iraqi self-rule.

b. (U) In actuality, LTG Sanchez and his V Corps staff rapidly realized that the war had not ended. They were in a counter-insurgency operation with a complex, adaptive enemy that opposed the rule of law and ignored the Geneva Conventions. This enemy opposed the transition of the new Iraqi governing councils that would enable self-rule, and opposed any occupation by U.S. or coalition forces. The hostilities continued. Operations were planned and executed to counter the insurgency.

c. (U) In June 2003, when the CJTF-7 organization was established, a vast increase in responsibilities began. A Joint Manning Document (JMD) was developed to delineate the specific skill sets of personnel needed to perform the increased roles and functions of this new headquarters. After multiple reviews, the JMD for the CJTF-7 HQ5 was formally approved for 1400 personnel in December 2003. That JMD included personnel needed to support the Coalition Provisional Authority (CPA), staff the functional elements needed to focus at joint operational and strategic levels, and specifically augment areas such as intelligence, operations, and logistics. Building a coherent, focused team was essential to the success of Phase IV operations.

d. (U) CJTF-7 remained in the direct chain of command of the U.S. Central Command, but also was charged with a direct support role to the CPA. Command relationships of subordinate tactical commands previously under V Corps remained as previously outlined in Operational Orders. Therefore, the divisions' and Corps' separate brigades, which included the 205th MI Brigade, remained under the CJTF-7. The level of authority and responsibilities of a command of this magnitude is normally vested in a four-star level Army Service Component Command under a Regional Combatant Commander. Of the 1400 personnel required on the JMD, the V Corps staff transitioned to only 495, or roughly a third, of the manning requirements. The new JMD also required that key staff positions be manned by general officers rather than the normal

UNCLASSIFIED

UNCLASSIFIED

colonel level positions on a Corps staff Although the JMD was properly staffed and approved, personnel and equipment shortages impacted on CJTF-7's ability to execute the mission and remained a critical issue throughout the period in question. The JMD had 169 positions earmarked for support of operations at Abu Ghraib.

(1) (S/NF)

(2) (U) The 800th MP Brigade remained TACON to the CJTF-7 throughout this period. With the essential task and responsibility for all EPW and confinement operations transferring from CFLCC to CJTF-7, this unit would have been more appropriately designated as OPCODE instead of TACON to the CJTF. Tactical Control (TACON) allows commanders the detailed and usually local direction and control of movements and maneuver necessary to accomplish missions and tasks. Whereas, Operational Control (OPCON) provides full authority to organize commands and forces and employ them as the commander considers necessary to accomplish assigned missions. The 800th MP Brigade's parent unit in the area of operations remained the 377th Theater Support Command, located in Kuwait. In accordance with the CENTCOM OPLAN, CFLCC (ARCENT) had to provide operational logistic support to Army Forces employed from Kuwait. The TACON relationship of the 800th MP Brigade with CJTF-7 resulted in disparate support from the CJTF-7 staff, lower priority in meeting resource needs for detention facilities, and the lack of intrusive, aggressive oversight of the unit by CJTF-7 leadership. No attempt was made by the CJTF-7 or ARCENT Staff to coordinate a change in this command relationship.

e. (U) Following the period of major ground hostilities in Phase III operations, the infrastructure of the country remained in desperate need of reconstruction. In addition to battle damage, looting, pillaging, and criminal actions had decimated the government buildings and infrastructure necessary to detain enemy prisoners of war or criminals.

f. (U) The logistics system, including local contracted support, to support units in Iraq was slowly catching up to the priority requirements that needed to be executed. Improving living conditions and basic support for Soldiers, as well as ensuring the safety and security of all forces, remained priorities, especially with the advent of the counter-insurgency. Quality of life for Soldiers did not improve in many locations until December of 2003.

g. (U) Prior to the beginning of hostilities, planners estimated 30-100 thousand enemy prisoners of war would need to be secured, segregated, detained, and interrogated. The 800th MP Brigade was given the mission to establish as many as twelve detention centers, to be run by subordinate battalion units. As of May 2003, BG Hill reported that only an estimated 600 detainees were being held - a combination of enemy prisoners and criminals. As a result, additional military police units previously identified for deployment were demobilized in CONUS. The original plan also envisioned that only the prisoners remaining from the initial major combat operations would require detention facilities, and they would eventually be released or turned over to the Iraqi authorities once justice departments and criminal detention facilities were re-established.

h. (U) As major counter-insurgency operations began in the July 2003 timeframe, the demands on the CJTF-7 commander and staff, the CPA, the subordinate units, the Iraqi interim

UNCLASSIFIED

UNCLASSIFIED

government, and Soldiers at all levels increased dramatically. Decisions were made to keep some units in-country to fight the insurgency. Pressure increased to obtain operational intelligence on the enemy's identity, support systems, locations, leadership, intelligence sources, weapons and ammunition caches, and centers of gravity. In addition, the location of Saddam Hussein and information on WMD remained intelligence priorities. The complexity of missions being conducted by CJTF-7 and subordinate units increased and placed a high demand on leadership at all levels. Leaders had to adapt to the new environment and prosecute hostilities, while at the same time exercising appropriate compassion for non-combatants and protecting the people who were trying to do what was right for their country. Operations were planned to pursue the various factions of the counter-insurgency based on intelligence developed with the Iraqi people and Coalition Forces. A rapid increase in the number of detainees (due to the apprehension of counter-insurgents who posed a security risk to our Soldiers and to the Iraqi people, members of criminal factions, and personnel of intelligence value) demanded a decision on a detention facility and a need to rapidly expand interrogation operations.

i. (U) Throughout the Iraqi Theater of Operations (ITO), synchronization of force protection and security operations between operational forces and forward operating bases, such as Abu Ghraib, demanded more focus by brigade-level leadership. Supported-to-supporting relationships were blurred due to the large geographical areas given to tactical units. At Abu Ghraib, outside-the-wire responsibilities during the period in question were the responsibility of the 3d Armored Cavalry Regiment and then the 82d Airborne Division. Force Protection and security for the Abu Ghraib forward operating base was an implied task for the 320th MP Battalion initially, and then, after the 19 November FRAGO, a specified task for the 205th MI Brigade Commander. The defense and security of the Abu Ghraib forward operating base, to include engaging the communities outside of the base for information, was a key concern of LTG Sanchez during his visits and led to the decision to place the 205th MI Brigade commander in charge of forces at Abu Ghraib for force protection and defense of the base in November 2003.

j. (U) Interrogating detainees was a massive undertaking. In accordance with doctrine, unit level personnel would gather initial battlefield intelligence at the point of apprehension. Tactical interrogations would continue at designated collection points (CP) at Brigade and Division levels. Then a more detailed interrogation to get operational and strategic intelligence was to be conducted at a designated central detention facility. The location and facility for this detention and interrogation was Abu Ghraib. Abu Ghraib was selected by Ambassador Bremer after consultation with his staff and LTG Sanchez. Abu Ghraib was envisioned as a temporary facility to be used for criminal detainees until the new Iraqi government could be established and an Iraqi prison established at another site. Following operations during the summer of 2003, Abu Ghraib also was designated by CJTF-7 as the detention center for security detainees. The population of criminals, security detainees, and detainees with potential intelligence value grew to an estimated 4000-5000 personnel in the fall of 2003.

k. (U) The 800th MP Brigade was designated the responsible unit for the Abu Ghraib detention facility and for securing and safeguarding the detainees. The 205th MI Brigade was given responsibility for screening and interrogating detainees at Abu Ghraib. The 320th MP battalion was the unit specifically charged with operating the Abu Ghraib detainee facility by the 800th MP Brigade. Initially, the 205th MI Brigade commander did not specify an MI unit or organization for interrogation operations at Abu Ghraib. Interrogators, analysts, and linguists arrived at Abu Ghraib from multiple units and locations within the 205th MI Brigade.

UNCLASSIFIED

UNCLASSIFIED

Contractor personnel were also later used to augment interrogation, analyst, and linguist personnel at Abu Ghraib.

5. (U) Assessments and Visits to Improve Intelligence, Detention and Interrogation Operations

a. (U) As commanders at all levels sought operational intelligence, it became apparent that the intelligence structure was undermanned, under-equipped, and inappropriately organized for counter-insurgency operations. Upon arrival in July 2003, MG Barbara Fast was tasked to do an initial assessment of the intelligence architecture needed to execute the CJTF-7 mission in Iraq. Technical intelligence collection means alone were insufficient in providing the requisite information on an enemy that had adapted to the environment and to a high-tech opponent. Only through an aggressive structure of human intelligence (HUMINT) collection and analysis could the requisite information be obtained. Communications equipment, computers, and access to sufficient bandwidth to allow reachback capabilities to national databases were needed to assist in the fusion and collaboration of tactical through strategic intelligence data. Disparate cells of different agencies had to be co-located to allow access to respective data bases to assist in the fusion and collaboration effort. Interrogation reports had to be standardized and rapidly reviewed to allow dissemination to subordinate tactical units, coalition allies, Iraqis, and other personnel at the unclassified level.

b. (U) Following MG Fast's initial assessment and report to CENTCOM headquarters, changes began to take place to put the right architecture in place. An Intelligence Fusion Cell was established, as were a Joint Inter-Agency Task Force and an expanded JC2X HUMINT Management Cell, at CJTF-7 headquarters. The CPA staff was augmented with military personnel from the CJTF-7 intelligence staff. With the assistance of the Department of the Army Staff, CJTF-7 obtained needed communications equipment, computers, and reachback access to the Information Dominance Center (IDC) to collaborate intelligence information. The focus of the previous V Corps staff, which formed the nucleus of the initial CJTF-7 staff, rapidly changed from a tactical focus to a joint operational and strategic level focus. The subsequent successes of this new intelligence architecture created by MG Fast and her team exponentially improved the intelligence process and saved the lives of Coalition Forces and Iraqi civilians. HUMINT operations and the fusion of intelligence led to the capture of key members of the former regime, and ultimately, to the capture of Saddam Hussein himself. During the time period of the Abu Ghraib abuses, the intelligence focus was on Saddam Hussein's capture and exploitation of documents related to Saddam Hussein, preparation for Ramadan, and large scale enemy activity at Fallujah and Najaf. The effort to expand the intelligence organization, obtain operational intelligence about the counter-insurgency, and support the CPA consumed the efforts of the CJTF-7 staff. Responsibilities for oversight of tactical interrogation procedures, Intel analysis, and reporting at Abu Ghraib as throughout the ITO, were entrusted to the commanders in the field.

c. (U) Due to the expanded scope of the mission for this new organization, the need to gain operational intelligence about the counter-insurgency, and the rapid and unexpected number of detainees, assistance was requested to help inform the leadership on proper procedures, techniques, and changes needed for success. The assessment visit by MG Ryder greatly assisted

UNCLASSIFIED

UNCLASSIFIED

the review and improvement of detention operations. Ryder's recommendations to automate the in-processing and accountability of detainees using the Biometrics Automated Tool Set (BATS), to discipline the audit trail of detainees from point of capture to the central detention facility, and to properly segregate different groups, were implemented.

d. (S/NF)

e. (U) MG Fast's initial assessment and report on the intelligence organization and the needed systems architecture to support the mission was invaluable to establishing a roadmap for needed intelligence resources. LTG Alexander, the DA G2, was instrumental in providing needed equipment and guidance to improve the intelligence collection and fusion capabilities in Iraq. LTG Alexander was specifically helpful in getting the equipment necessary to support the intelligence architecture from the tactical to the strategic fusion levels.

6. (U) Indications and Warnings

a. (U) In retrospect, indications and warnings had surfaced at the CJTF-7 level that additional oversight and corrective actions were needed in the handling of detainees from point of capture through the central collection facilities, to include Abu Ghraib. Examples of these indications and warnings include: the investigation of an incident at Camp Cropper, the International Committee of the Red Cross (ICRC) reports on handling of detainees in subordinate units, ICRC reports on Abu Ghraib detainee conditions and treatment, CID investigations and disciplinary actions being taken by commanders, the death of an OGA detainee at Abu Ghraib, the lack of an adequate system for identification and accountability of detainees, and division commanders' continual concerns that intelligence information was not returning to the tactical level once detainees were evacuated to the central holding facility. The Commander, CJTF-7, recognized the need to place emphasis on proper handling of detainees and proper treatment of the Iraqi people in close proximity to operations. In October and December 2003, CDR, CJTF-7 published two policy memos entitled "Proper treatment of the Iraqi people during combat operations" and "Dignity and respect while conducting operations." Reports from the assessments of MG Miller and MG Ryder clearly confirmed the CJTF-7 Commander's instincts that action was needed to improve procedures and set the conditions for success in intelligence and detention operations. The report from the CID in January 2004 and subsequent investigation by MG Taguba confirmed that abuses occurred at Abu Ghraib during the period under investigation.

b. (U) I would be remiss if I did not reemphasize that the 180,000 U.S. and coalition forces, under all echelons of command within the CJTF-7, were prosecuting this complex counter-insurgency operation in a tremendously horrid environment, and were performing above all expectations. Leaders and Soldiers confronted a faceless enemy whose hatred of the United States knew no limits. The actions of a few undisciplined Soldiers at Abu Ghraib have overshadowed the selfless service demonstrated every day, twenty-four hours a day, by the vast majority of our Soldiers and civilians on the battlefield. We, as a Nation, owe a debt of gratitude to our service members who have answered our Nation's call and are in harm's way, every day. This fact became perfectly clear to me as I conducted my investigation.

UNCLASSIFIED

UNCLASSIFIED

7. (U) Doctrine, Organizational Structure and Policy Challenges in the Iraqi Theater of Operations

a. (U) Doctrine and Organizational Structures

(1) (U) Doctrine could not provide quick solutions for all the situations that confronted CJTF-7. In many cases, the situation, mission, and environment dictated the decisions and the actions taken by the CJTF leadership. This situation is not uncommon. Rarely does war follow the pre-planned strategy. As the V Corps staff morphed to form the nucleus of the CJTF-7 staff, doctrine was not available to prescribe a detailed sequence to efficiently and effectively execute the transition. The new JMD focused on supplementing the V Corps headquarters structure to perform the expected mission in the Iraqi environment - stability and support operations and support of the CPA.

(2) (U) Joint Interrogation and Debriefing Center. In accordance with JP 2.01, the use of a JIDC by a JTF is situation-dependent. No defined organization exists for implementing the JIDC concept. At Abu Ghraib, a JIDC was established based on the recommendation of MG Miller during his assessment. At the time, Abu Ghraib had only a few hundred detainees. LTC Jordan was sent to Abu Ghraib to oversee the establishment of the JIDC. On 19 November 2003, when COL Thomas Pappas assumed the role of commander of the forward operating base, he directed activities of the JIDC and LTC Jordan became the deputy director of the JIDC. There are conflicting statements regarding who had the responsibilities to implement and oversee the JIDC at Abu Ghraib. In accordance with doctrine, the CJTF-7 C2, MG Fast, through her JC2-X staff, provided priority intelligence requirements for the interrogators and analysts in the JIDC. A portion of the approved CJTF-7 JMD earmarked 169 personnel for the interrogation operations and analysis cells in the JIDC. Many of these positions were later filled with contractor personnel. Although a senior officer was directed to be the Chief, JIDC, the establishment and efficient operation of the JIDC was further complicated by the lack of an organizational MI unit and chain of command at Abu Ghraib solely responsible for MI personnel and intelligence operations.

(3) (U) MI & MP Responsibilities at Abu Ghraib The delineation of responsibilities for interrogations between the military intelligence and military police may not have been understood by some Soldiers and some leaders. The doctrinal implications of this issue are discussed later in this report. At Abu Ghraib, the lack of an MI commander and chain of command precluded the coordination needed for effective operations. At the same time, LTC Jordan failed to execute his responsibilities as Chief, JIDC. Tactical doctrine states that interrogators should specify to the guards what types of behavior on their part will facilitate screening of detainees. Normally, interrogation facilities are collocated with detention facilities, requiring close coordination between the MPs who are responsible for detention operations, and the MI personnel who are responsible for screening and interrogations. Both doctrinal manuals, for military police and military intelligence operations, clearly provide that Soldiers and units must obey rules of land warfare and, specifically, the Geneva Conventions when handling detainees. At Abu Ghraib, the delineation of responsibilities seems to have been blurred when military police Soldiers, untrained in interrogation operations, were used to enable interrogations. Problems arose in the following areas: use of dogs in interrogations, sleep deprivation as an interrogation technique and use of isolation as an interrogation technique.

UNCLASSIFIED

UNCLASSIFIED

(4) (U) CJTF-7 Staff Responsibility. CJTF-7 responsibility for staff oversight of detention operations, facilities, intelligence analysis and fusion, and limits of authority of interrogation techniques was dispersed among the principal and special staff. Overall responsibility for detention operations was vested in the C3, MG Tom Miller, with further delegation to the Provost Marshal. Support of facilities was a C4 responsibility, with priorities of work established by the DCG, MG Walter Wojdakowski. MG Wojdakowski also had direct responsibility and oversight of the separate brigades assigned or TACON to CJTF-7. Priorities for intelligence collection, analysis and fusion were the responsibility of the C2, MG Fast. Lastly, LTG Sanchez used his Staff Judge Advocate, Colonel Marc Warren, to advise him on the

limits of authority for interrogation and compliance with the Geneva Conventions for the memos published. The lack of one person on the staff to oversee detention operations and facilities, and the responsibilities of all units at a detention facility complicated effective and efficient coordination among the staff Subordinate brigade commanders and their staffs also had to coordinate different actions for support with the various staff sections responsible for the support requested.

b. (U) Policy

(1) (U) Policy Guidance. DOD-wide, formal written policies for interrogation techniques have been prescribed by various levels of command and authority. In most cases, the doctrinal reference is FM 34-52, Intelligence Interrogation, dated September 1992. As stated, this manual is currently under revision by the proponent. During the period under investigation, there was confusing and sometimes conflicting guidance resulting from the number of policy memos and the specific areas of operation the various policies were intended to cover. Each theater's techniques for interrogation and counter-resistance were reviewed by appropriate legal authorities and subjected to external assessments before commanders were advised of their acceptability. In the wartime settings of each theater, commanders were satisfied that appropriate oversight had been conducted for procedures being used for interrogations. However, when reviewing the various reports on the number of abuses in the ITO, it became clear there is no agreed upon definition of abuse among all legal, investigating and oversight agencies.

(2) (U) Interrogation techniques, including Counter-Resistance Techniques, were developed and approved for the detainees in Guantanamo and Afghanistan who were determined not to be EPWs or protected persons under the Geneva Conventions of 1949. The OSD memo promulgated in December 2002, approving techniques and safeguards for interrogation of unlawful combatants in GTMO, included the use of dogs to induce stress and the removal of clothing as Counter-Resistance Techniques. This memo was rescinded in January 2003. A General Counsel Interrogation Working Group was subsequently formed and published a revised memo in April 2003 under the signature of the SECDEF on Counter-Resistance Techniques. This memo produced by the Working Group and the techniques outlined in FM 34-52 were referenced by Colonel Warren and his staff to develop the limits of authority memo for LTG Sanchez. The provisions of Geneva Convention IV, Relative to Protection of Civilian Persons in Time of War, did apply to detainees in Iraq.

(3) (U) Initially, no theater-specific guidance on approved interrogation techniques was published by CJTF-7 for the ITO. Thus, LTG Sanchez reemphasized the limits of authority for

UNCLASSIFIED

UNCLASSIFIED

interrogations in his memos dated 14 September 2003 and 12 October 2003. The first was rescinded, and the second addressed only security detainees and, inadvertently, left certain issues for interpretation: namely, the responsibility for clothing detainees, the use of dogs in interrogation, and applicability of techniques to detainees who were not categorized as "security detainees." Furthermore, some military intelligence personnel executing their interrogation duties at Abu Ghraib had previously served as interrogators in other theaters of operation, primarily Afghanistan and GTMO. These prior interrogation experiences complicated understanding at the interrogator level. The extent of "word of mouth" techniques that were passed to the interrogators in Abu Ghraib by assistance teams from Guantanamo, Fort Huachuca, or amongst themselves due to prior assignments is unclear and likely impossible to definitively determine. The clear thread in the CJTF-7 policy memos and published doctrine is the humane treatment of detainees and the applicability of the Geneva Conventions. Experienced interrogators will confirm that interrogation is an art, not a science, and knowing the limits of authority is crucial. Therefore, the existence of confusing and inconsistent interrogation technique policies contributed to the belief that additional interrogation techniques were condoned in order to gain intelligence.

8. (U) Specific Comments on Abuse at Abu Ghraib

a. (U) This report, so far, has discussed the OPLAN background, operational environment, and policy, doctrine and structural decisions that created conditions which allowed the abuses at Abu Ghraib to occur. The earlier investigations aptly described what happened at Abu Ghraib. MG Taguba found that "numerous incidents of sadistic, blatant, and wanton criminal abuses were inflicted on detainees." MG Fay identified forty-four incidents of detainee abuse and his report describes the particular abuses in detail. In this section, I rely on the statements and other investigative activity from MG Fay. The conclusions, however, are my own. Clearly, shameful events occurred at the detention facility of Abu Ghraib and the culpable MI and MP Soldiers and leaders should be held responsible. In this section, I set forth an analytical framework for categorizing the abuses propose causes for the incidents of abuse, and also discuss the culpability of organizations and personnel higher than the 205th MI Brigade Commander.

b. (U) For purposes of this report, I defined abuse as treatment of detainees that violated U.S. criminal law (including the Uniform Code of Military Justice (UCMJ)) or international law, or treatment that was inhumane or coercive without lawful justification. Whether the Soldier or contractor knew, at the time of the acts, that the conduct violated any law or standard, is not an element of the definition. In other words, conduct that met the definition would be "abuse" independent of the actor's knowledge that the conduct violated any law or standard.

c. (U) For clarity of analysis, my assessment divides abuses at Abu Ghraib into two different types of improper conduct: first, intentional violent or sexual abuses and, second, actions taken based on misinterpretation of or confusion about law or policy.

(1) (U) Intentional violent or sexual abuses, for purposes of this report, include acts causing bodily harm using unlawful force as well as sexual offenses including, but not limited to rape, sodomy and indecent assault.² These incidents of physical or sexual abuse are serious

².As those offenses are defined in the Uniform Code of Military Justice.

UNCLASSIFIED

UNCLASSIFIED

enough that no Soldier or contractor believed the conduct was based on official policy or guidance. If proven, these actions would be criminal acts. I found that no policy, directive, or doctrine caused the violent or sexual abuse incidents. Soldiers knew they were violating the approved techniques and procedures. The primary causes of these actions were relatively straight-forward individual criminal misconduct, clearly in violation of law, policy, and doctrine and contrary to Army values.

(2) (U) The second category of abuse consists of incidents that resulted from misinterpretations of law or policy or resulted from confusion about what interrogation techniques were permitted by law or local SOPs. I found that misinterpretation as to accepted practices or confusion occurred due to the proliferation of guidance and information from other theaters of operation; individual interrogator experiences in other theaters; and, the failure to distinguish between permitted interrogation techniques in other theater environments and Iraq. These abuses include some cases of clothing removal (without any touching), some use of dogs in interrogations (uses without physical contact or extreme fear) and some instances of improper imposition of isolation. Some of these incidents involve conduct which, in retrospect, violated international law. However, at the time some of the Soldiers or contractors committed the acts, they may have honestly believed the techniques were condoned. Some of these incidents either took place during interrogations or were related to interrogation. Often, these incidents consisted of MP Soldiers, rather than MI personnel, implementing interrogation techniques.

d. (U) Some abuses may in fact fall in between these two categories or have elements of both. For instance, some Soldiers under the guise of confusion or misinterpretation may actually have intentionally violated approved interrogation techniques. For example, a Soldier may know that clothing removal is prohibited, but still removed some of a detainee's clothing to try to enhance interrogation techniques. This Soldier can later claim to have believed the actions were condoned. Soldier culpability in this area is best left to individual criminal or command investigations. While no analytical scheme can aptly categorize all misconduct, I think using the two categories set forth above helps explain why the entire range of abuses occurred.

e. (U) The appointment memo directed me to determine whether organizations or personnel higher than the 205th MI Brigade chain of command were involved directly or indirectly, in the questionable activities regarding alleged detainee abuse at Abu Ghraib prison.

(1) (U) I find no organization or individual higher in the chain of command of the 205th MI Brigade were directly involved in the questionable activities regarding alleged detainee abuse at Abu Ghraib prison.

(2) (U) CJTF-7 leaders and staff actions, however, contributed indirectly to the questionable activities regarding alleged detainee abuse at Abu Ghraib.

(a) (U) Policy memoranda promulgated by the CJTF-7 Commander led indirectly to some of the non-violent and non-sexual abuses. The policy memos promulgated at the CJTF-7 level allowed for interpretation in several areas, including use of dogs and removal of clothing. Particularly, in light of the wide spectrum of interrogator qualifications, maturity, and experiences (i.e. in GTMO and Afghanistan), the memos did not adequately set forth the limits on interrogation techniques. Misinterpretations of CJTF policy memos led to some of the abuses at Abu Ghraib, but did not contribute to the violent or sexual abuses.

UNCLASSIFIED

UNCLASSIFIED

(b) (U) Inaction at the CJTF-7 staff level may have also contributed to the failure to discover and prevent abuses before January 2004. As discussed above, staff responsibility for detention and interrogation operations was dispersed among the Deputy Commanding General, C2, C3, C4 and SJA. The lack of a single CJTF-7 staff proponent for detention and interrogation operations resulted in no individual staff member focusing on these operations. As discussed in Section V, certain warning signs existed. In addition, there is sufficient evidence to reasonably believe that personnel in the CJTF-7 staff, principally in the OSJA and JC2X had knowledge of potential abuses and misconduct in violation of the Geneva Conventions at Abu Ghraib. This knowledge was not presented to the CJTF-7 leadership. Had the pace of combat operations and support to the CPA not been so overwhelming, the CJTF-7 staff may have provided additional oversight to interrogation operations at Abu Ghraib. The Commander, CJTF-7 had to prioritize efforts and CJTF-7, by necessity, devoted its resources to fighting the counter-insurgency and supporting the CPA, thereby saving U.S. and civilian Iraqi lives and assisting in the transition to Iraqi self-rule. Further, LTG Sanchez and MG Wojdakowski relied upon two senior officer Brigade Commanders (BG Janice Karpinski and COL Pappas) to run detention and interrogation operations at Abu Ghraib. In my professional opinion, in light of all the circumstances, the CJTF-7 staff did everything they could have reasonably been expected to do to successfully complete all their assigned missions.

f. (U) Assessing the materials from MG Fay and from MG Taguba, I agree that leadership failure, at the brigade level and below, clearly was a factor in not sooner discovering and taking actions to prevent both the violent/sexual abuse incidents and the misinterpretation/confusion incidents. At Abu Ghraib, interrogation operations were also plagued by a lack of an organizational chain of command presence and by a lack of proper actions to establish standards and training by the senior leaders present.

(1) (U) The leaders from 205th MI and 800th MP Brigades located at Abu Ghraib or with supervision over Abu Ghraib, failed to supervise subordinates or provide direct oversight of this important mission. The lack of command presence, particularly at night, was clear.

(2) (U) The 205th Brigade Commander did not specifically assign responsibility for interrogation operations to a specific subordinate MI unit at Abu Ghraib and did not ensure that a chain of command for the interrogation operations mission was established at Abu Ghraib. The presence of a clear chain of Military Intelligence command and associated responsibilities would have enhanced effective operations.

(3) (U) The leaders from 205th MI and 800th MP Brigades located at Abu Ghraib or with supervision over Soldiers and units at Abu Ghraib, failed to properly discipline their Soldiers and failed to develop and learn from AARs and lessons learned.

(4) (U) These leaders failed to provide adequate mission-specific training to execute a mission of this magnitude and complexity.

(5) (U) A dysfunctional command relationship existed between the MI Brigade and the MP Brigade, including:

(a) Failure to coordinate and document specific roles and responsibilities;

UNCLASSIFIED

UNCLASSIFIED

(b) Confusion at the Soldier level concerning the clarity of the MP role in interrogations.

(6) (U) Despite these leadership deficiencies, the primary cause of the most egregious violent and sexual abuses was the individual criminal propensities of the particular perpetrators. These individuals should not avoid personal responsibility, despite the failings of the chain of command.

g. (U) Other Contributing Factors. No single, or simple, cause explains why some of the Abu Ghraib abuses happened. In addition to the leadership failings discussed above, other contributing factors include:

(1) (U) Safety and security conditions at Abu Ghraib. Resources that might otherwise have been put towards detention operations instead had to be dedicated to force protection. In addition, the difficult circumstances for Soldiers, including a poor quality of life and the constant threat of death or serious injury, contributed to Soldiers' frustrations and increased their levels of stress. Facilities at Abu Ghraib were poor. Working and living conditions created a poor climate to conduct interrogation and detention operations to standard.

(2) (U) The lack of clear and consistent guidance, promulgated at the CJTF level on interrogation procedures coupled with the availability of information on Counter-Resistance Techniques used in other theaters.

(3) (U) Soldier knowledge of interrogation techniques permitted in GTMO and Afghanistan and failure to distinguish between those environments and Iraq.

(4) (U) Interaction with OGA and other agency interrogators who did not follow the same rules as U.S. Forces. There was at least the perception, and perhaps the reality, that non-DOD agencies had different rules regarding interrogation and detention operations. Such a perception encouraged Soldiers to deviate from prescribed techniques.

(5) (U) Integration of some contractors without training, qualifications, and certification created ineffective interrogation teams and the potential for non-compliance with doctrine and applicable laws.

(6) (U) Under-resourcing of personnel in both the 800th MP BDE (including the inability to replace personnel leaving theater) and in the 205th MI Brigade, specifically in the interrogator, analyst, and linguist fields. (Under-resourcing at the CJTF-7 level also contributed and was previously discussed.)

(7) (U) Lack of a clear understanding of MP and MI roles and responsibilities by some Soldiers and leaders.

(8) (U) Lack of clear roles and responsibilities for tactical, as opposed to, strategic interrogation.

UNCLASSIFIED

UNCLASSIFIED

9. (U) Assessments as the Senior Investigating Officer

a. (U) Introduction. Due to the previous assessments and investigations conducted on Abu Ghraib, I was able to develop my own assessments based on interviews I conducted, the findings and conclusions in the earlier reports, as well as the materials in MG Fay's report. The following assessments provide insight on the challenges that CJTF-7 faced, as well as areas that need to be addressed by our military in the near future. The specific investigations and assessments were provided by the reports of MG Miller, MG Ryder, MG Taguba, the DAIG, and MG Fay.

b. (U) Charters. MG Miller's and MG Ryder's assessments were conducted on interrogation and detention operations as a result of the request and/or discussions by the CJTF Commander and the Commander, CENTCOM. MG Taguba and MG Fay were directed to investigate personnel in the MP Brigade and the MI Brigade after the discovery of abuses at Abu Ghraib. The DAIG was specifically tasked to conduct an assessment of Detainee Operations as the Army executes its role as DOD Executive Agent for Enemy Prisoners of War and Detention Program.

c. (U) Summaries of assessment visits. The assistance visits by MG Miller and MG Ryder, discussed briefly above, confirmed the instincts of the Commander, CJTF-7, and provided solid recommendations for improving procedures. MG Miller's assessment set forth what had to be done to synchronize intelligence efforts, and provided different techniques in interrogation and analysis. MG Ryder provided processes for more efficient and effective chain of custody of, and accountability for, detainees. MG Taguba's and MG Fay's investigative reports confirmed that abuses occurred and assigned specific responsibility for the actions. The DAIG report provided insights across doctrine, organizations, training, materiel, leadership, personnel and facilities (DOTMLPF) and on capability and standards shortfalls. I found that the assistance visits by senior leaders with experience in detention and interrogation operations, subject matter experts, and mobile training teams were extremely helpful in validating needed procedures and increasing the effectiveness of interrogation and detention operations. The investigative reports and DAIG findings will be used to fix deficiencies that have been found in current operations.

d. (U) Doctrine.

(1) (U) Doctrine is meant to be a guideline to focus efforts in a specific area. Doctrine is the culmination of years of experience, Doctrine allows leaders at all levels to adapt to the different environments and situations that their units may encounter. When prosecuting hostilities, doctrine does not replace the inherent responsibilities of commanders to execute their missions, care for the safety and security of their Soldiers, train their Soldiers and their organizations to be competent and confident in their assigned duties and responsibilities, or uphold the rule of law and legal authority such as the Geneva Convention. An overarching doctrine allows commanders the latitude to develop tactics, techniques, and procedures, as well as unit standard operating procedures, to focus Soldier and unit operations. Commander policies and directives often supplement or emphasize specific items that the commander wants to ensure are clearly understood within their command.

(2) (U) Basic Army and Joint doctrine for detention and interrogation operations served as a guideline for operations in OIF. Doctrine did not cause the abuses at Abu Ghraib. Had Army

UNCLASSIFIED

UNCLASSIFIED

doctrine and training been followed, the abuses at Abu Ghraib would not have occurred. Several areas, however, need to be updated, refined or expanded: roles, responsibilities and relationships between MP and MI personnel; the concept, structure, and organization of a JIDC; the transition to and organization of a JTF structure and in particular, the intelligence organization within the JTF headquarters.

(a)(U) Roles, responsibilities and relationships between MP and MI personnel. The various investigations indicate that the delineation of responsibilities for interrogations between the military intelligence and military police may not have been understood by some Soldiers and some leaders. At Abu Ghraib, non-violent and non-sexual abuses may have occurred as a result of confusion in three areas of apparent MI/MP overlap: use of dogs during interrogations, nudity, and implementation of sleep deprivation. Doctrinal manuals prescribe responsibilities for military intelligence and military police personnel at detention facilities. These manuals do not address command or support relationships. Subordinate units of the military intelligence brigade of a Corps are normally tasked with running the Corps Interrogation Facility (CIF). Centralized EPW collection and holding areas, as well as detention centers, are the responsibility of the Military Police with staff oversight by the Provost Marshal. FM 34-52, Intelligence Interrogation, does state that in the screening process of EPWs, MPs and MI Soldiers should coordinate roles.

(b)(U) Relationships between MP and MI personnel and leadership responsibilities at a detention facility of this magnitude need to be more prescriptive. Doctrine establishes the need for coordination and designates detention operations as a military police responsibility. Responsibility for interrogation of detainees remains with the military intelligence community. Doctrine for Interrogation operations states that MPs can enable, in coordination with MI personnel, a more successful interrogation. Exact procedures for how MP Soldiers assist with informing interrogators about detainees or assist with enabling interrogations can be left to interpretation. Our doctrinal manuals are clear on humane treatment of detainees and compliance with the Geneva Conventions by MI, MP and all U.S. Forces. The current version of FM 34-52, Intelligence Interrogation, is under revision to incorporate lessons learned in ongoing theaters of operations. Lessons learned have also resulted in changes to programs of instruction by military police and military intelligence proponents. My assessment is that the ongoing revision of Intelligence Interrogation manuals will assist in clarification of roles and responsibilities. At Abu Ghraib, doctrinal issues did not preclude on-site leaders from taking appropriate action to execute their missions.

(c)(U) The Joint Interrogation and Debriefing Center. The JIDC was formed at Abu Ghraib by personnel from a number of organizations, creating an ad hoc relationship. Further, the establishment of the JIDC at Abu Ghraib, coupled with implementing the new Tiger Team approach to interrogations (where an interrogator, analyst, and linguist operate as a team) were new to Abu Ghraib personnel and demanded creation of a detailed standard operating procedure (SOP). A SOP was initially developed and published in October 2003 by MI personnel at the facility. Joint doctrine needs to expand on the operation and organization for a JIDC at centralized detention facilities. A template for a JIDC needs to be developed, to include identifying Joint and other agency resources with strategic interrogation expertise, to provide insight for combatant commanders in specific areas of operation.

UNCLASSIFIED

20

UNCLASSIFIED

(d)(U) Joint doctrine and policy should also address the roles of military personnel and other agencies in collocated detention and interrogation facilities. All detainees must be in-processed, medically screened, accounted for, and properly documented when interned in a military facility. This did not happen at Abu Ghraib.

(3) (U) Transition to and Organization of JTF Structure and its Intelligence Architecture. The intelligence architecture for the missions tasked to the CJTF-7 was inadequate due to the expanded mission and continuation of hostilities in theater. Several reports stated that lack of manning provided significant challenges due to the increased mission work load and the environment. Certainly, the V Corps Headquarters was not trained, manned or equipped to assume the role of a CJTF. Although the mission was initially considered to be SASO, in fact hostilities continued. CI/HUMINT capabilities in current force structure, among all services, needs a holistic review. The Army has significantly reduced tactical interrogators since Desert Shield/Desert Storm. Creation of the Defense HUMINT Service and worldwide demands for these skills has depleted the number of experienced interrogators that may be needed in the future joint operational environment. The HUMINT management organization within the Intelligence Staff of a JTF needs to be institutionalized and resourced. Specifically, work needs to be done to institutionalize the personnel and equipment needs for future command and control headquarters to include the JIATF and C2X cells within a JTF intelligence staff.

(4) (U) In addition, the ongoing review by the Army and Joint Forces Command to create JTF capable headquarters and Standing Joint Task Force Headquarters organic to combatant commands should be expedited and resourced. Such efforts may have helped transition V Corps to the CJTF-7 staff more rapidly by assigning a Standing Joint Task Force to the CJTF-7. Similarly, the Army's initiative to develop stand alone command and control headquarters, currently known as Units of Employment, that are JTF-capable would have greatly facilitated the transition of the V Corps staff to the new organization.

e. (U) Policy and Procedures

(1) (U) Detention Operations. At first, at Abu Ghraib and elsewhere in Iraq, the handling of detainees, appropriately documenting their capture, and identifying and accounting for them, were all dysfunctional processes, using little or no automation tools. The assistance visits by MG Miller and MG Ryder revealed the need to adhere to established policies and guidance, discipline the process, properly segregate detainees, and use better automation techniques to account for detainees and to provide timely information.

(2) (U) Interrogation Techniques Policy. A review of different theaters' interrogation technique policies reveals the need for clear guidance for interrogation techniques at both the tactical and strategic levels, especially where multiple agencies are involved in interrogation operations. The basic Field Manuals provide guidance for Soldiers conducting interrogations at the tactical level. Different techniques and different authorities currently exist for other agencies. When Army Soldiers and other agency personnel operate in the same areas, guidelines become blurred. The future joint operational environment presents a potential for a mix of lawful and unlawful combatants and a variety of different categories of detainees. Techniques used during initial battlefield interrogations as opposed to at a central detention facility differ in terms of tactical versus more strategic level information collection. The experience, maturity, and source of interrogators at each of these locations may also dictate a change in techniques. In each

UNCLASSIFIED

UNCLASSIFIED

theater, commanders were seeking guidance and information on the applicability of the articles of the Geneva Conventions to specific population sets and on what techniques could be used to improve intelligence production and remain within the limits of lawful authorities.

(a)(U) At Abu Ghraib, the lack of consistent policy and command oversight regarding interrogation techniques, coupled with changing policies, contributed to the confusion concerning which techniques could be used, which required higher level approval, and what limits applied to permitted techniques. Initially, CJTF-7 had no theater-specific guidance other than the basic Field Manuals which govern Intelligence Interrogations and Internment and Resettlement operations. Policies for interrogation techniques including policies for Counter-Resistance Techniques, were provided for different theaters of operation—namely Guantanamo, Afghanistan, and Iraq. Some interrogators conducting operations at Abu Ghraib had experience in different theaters and used their experiences to develop procedures at Abu Ghraib. An example of this is the SOP for the JIDC created by personnel of the 519th MI Battalion.

(b)(U) When policies, SOPs, or doctrine were available, Soldiers were inconsistently following them. In addition, in some units, training on standard procedures or mission tasks was inadequate. In my assessment, I do not believe that multiple policies resulted in the violent or sexual abuses discovered at Abu Ghraib. However, confusion over policies contributed to some of the non-violent and non-sexual abuses. There is a need, therefore, to further refine interrogation techniques and limits of authority at the tactical versus the strategic level, and between Soldiers and other agency personnel.

(3) (U) Use of Military Detention Centers by Other Agencies. In joint military detention centers, service members should never be put in a position that potentially puts them at risk for non-compliance with the Geneva Conventions or Laws of Land Warfare. At Abu Ghraib, detainees were accepted from other agencies and services without proper in-processing, accountability, and documentation. These detainees were referred to as “ghost detainees.” Proper procedures must be followed, including, segregating detainees of military intelligence value and properly accounting and caring for detainees incarcerated at military detention centers. The number of ghost detainees temporarily held at Abu Ghraib, and the audit trail of personnel responsible for capturing, medically screening, safeguarding and properly interrogating the “ghost detainees,” cannot be determined.

f. (U) Training. The need for additional training during the mobilization phase or in-country on unit and specific individual tasks was clearly an issue in the reports and assessments. Some military police units found themselves conducting detention operations which was not a normal unit mission essential task, and those units needed additional training to properly accomplish the missions they were given. The collocation and mixture of other agency and civilian personnel conducting detention and interrogation operations became confusing for junior leaders and Soldiers not normally accustomed to working with other organizations. Collective training to standard by MP and MI units in combined scenarios as rigorous as the situations faced in OIF is needed to prepare for the future.

In addition, V Corps personnel, to include commanders and staff, were not trained to execute a JTF mission. The transition from major combat operations to a headquarters focused on SASO and support to the Coalition Provisional Authority was a major transition which the unit did not have time to train or prepare. Most importantly, we must continue to place rigor and

UNCLASSIFIED

UNCLASSIFIED

values in our training regimen. Our values are non-negotiable for members of our profession. They are what a professional military force represents to the world. As addressed before, leaders need rigorous training to be able to adapt to this level of complexity.

g. (U) Materiel. Priorities for logistical support remained with the operational units who were conducting combat operations and providing force protection and security of U.S. and coalition forces. Creating an intelligence organization to provide tactical through strategic intelligence in a seamless manner and the dramatic increase in detention operations demanded communications, computers, and a network to support operations. The concept of a Joint Logistics Command should be further examined using lessons learned from OIF/OEF. Automation equipment needed to provide seamless connectivity of intelligence information from tactical through strategic levels, and enable an Intelligence Fusion Center in a JTF should be documented and embedded in JTF capable headquarters. Equipment currently undergoing research and development and commercial off-the-shelf solutions which enable CI/HUMINT operations and enable Soldiers to serve as sensors and collectors should be rapidly pursued. The process of accounting for detainees, their equipment, and their personal property, and documenting their intelligence value, should be automated from the tactical level to the centralized detention facilities.

h. (U) Leader Development. The OIF environment demanded adaptive, confident, and competent leadership at all echelons. Leaders must set the example and be at the critical centers of gravity for their respective operations. Leaders set the example in a values-based profession. The risk to Soldiers and the security of all personnel demanded continued leader involvement in operations, planning, after-action reviews, and clear dissemination of lessons learned, to adapt to the dynamics of the counter-insurgency. Successful leaders were involved in their operations and were at the tip of the spear during critical periods. Leadership failure was seen when leaders did not take charge, failed to provide appropriate guidance, and did not conduct continual training. In some cases, leaders failed to accept responsibility or apply good judgment in executing assigned responsibilities. This latter fact is evident in the lack of a coordinated defense at Abu Ghraib, inconsistent training and standards, and lack of discipline by Soldiers. Commanders and leaders at all levels remain responsible for execution of their mission and the welfare of their Soldiers. In Iraq, leaders had to adapt to a new complex operational environment. Some of our leaders adapted faster than others. We must continue to put rigor in our leader and unit training. Leaders must be trained for certainty and educated for uncertainty. The ability to know how to think rather than what to think is critical in the future Joint Operational Environment. Specific leader and Soldier failures in the 800th MP Brigade and the 205th MI Brigade are identified in the investigative reports by MG Taguba and MG Fay. As discussed above, my review of echelons above brigade revealed that CJTF-7 leaders were not directly involved in the abuses at Abu Ghraib. Their actions and inaction did indirectly contribute to the non-sexual and non-violent abuses.

i. (U) Facilities. Facilities and quality of life for Soldiers and detainees were representative of the conditions throughout the AOR initially. Only when the logistics system became responsive to the needs of units and Soldiers, contracting mechanisms were put in place to support operations, and the transportation system matured to move supplies, were improvements seen in facilities and quality of life. The conditions at Abu Ghraib were representative of the conditions found throughout the country during post Phase III, Decisive Operations. The slow process of developing the logistics system and providing secure lines of

UNCLASSIFIED

UNCLASSIFIED

communication directly impeded Soldier security and quality of life.

10. (U) Concluding Findings and Recommendations

a. (U) SUMMARY AS SENIOR INVESTIGATING OFFICER. I derived these findings and recommendations from the observations and assessments discussed in sections 2-9, from the interviews I conducted, and from the documents I have reviewed. Furthermore, I support the recommendations of the Fay and Taguba Reports concerning individual culpability for actions that violated U.S. criminal law (including the Uniform Code of Military Justice (UCMJ)) or international law, or that was inhumane or coercive without lawful justification. The personnel who committed these acts did not act in accordance with the discipline and values that the U.S. Army represents. Leaders who had direct responsibilities for the actions of these individuals failed to adequately exercise their responsibilities in the execution of this mission.

b. (U) RESPONSIBILITY ABOVE 205th MI BRIGADE

(1) (U) Findings:

(a) (U) I find that the chain of command above the 205th MI Brigade was not directly involved in any of the abuses that occurred at Abu Ghraib.

(b) (U) I find that the chain of command above the 205th MI Brigade promulgated policy memoranda that, inadvertently, left room for interpretation and may have indirectly led to some of the non-violent and non-sexual abuse incidents.

(c) (U) I find that LTG Sanchez, and his DCG, MG Wojdakowski, failed to ensure proper staff oversight of detention and interrogation operations. As previously stated, MG Wojdakowski had direct oversight of two new Brigade Commanders. Further, staff elements of the CJTF-7 reacted inadequately to some of the Indications and Warnings discussed above. However, in light of the operational environment, and CJTF-7's under-resourcing and unplanned missions, and the Commander's consistent need to prioritize efforts, I find that the CJTF-7 Commander and staff performed above expectations, in the over-all scheme of OIF.

(d) (U) I find that the TACON relationship of the 800th MP Brigade to the CJTF-7 created a dysfunctional relationship for proper oversight and effective detention operations in the Iraqi Theater of Operations (ITO). In addition, the relationship between leaders and staff of the 205th MI Brigade and 800th MP Brigade was ineffective as they failed to effect proper coordination of roles and responsibilities for detention and interrogation operations.

(e) (U) I find that a number of causes outside of the control of CJTF-7 also contributed to the abuses at Abu Ghraib. These are discussed in Section 8 and include, individuals' criminal propensity; Soldier knowledge of interrogation techniques permitted in GTMO and Afghanistan and failure to distinguish between those environments and Iraq; interaction with OGA and other agency interrogators who did not follow the same rules as U.S. Forces; integration of some contractors without training, qualifications, and certification; under-resourcing of personnel in both the 800th MP BDE (including the inability to replace personnel leaving theater) and in the 205th MI Brigade, specifically in the interrogator, analyst, and linguist fields.

UNCLASSIFIED

UNCLASSIFIED

(2) (U) Recommendations:

(a) (U) That CJTF-7 designate a single staff proponent for Detention and Interrogation Operations. The grade of this officer should be commensurate with the level of responsibilities of the particular operation. Further, that the Army in concert with JFCOM should review the concept and clarify responsibilities for a single staff position for Detention and Interrogation operations as part of a JTF capable organization.

(b) (U) That CJTF-7 in concert with CENTCOM publish clear guidance that applies to all units and agencies on roles and responsibilities for Detention and Interrogation Operations, and publish clear guidance on the limits of interrogation authority for interrogation techniques as pertains to the detainee population in the ITO.

(c) (U) That CENTCOM review command relationship and responsibilities for the 800th MP Brigade with CJTF-7 in the conduct of detention operations in the ITO.

(d) (U) That the CJTF-7 Inspector General be designated the staff proponent to rapidly investigate ICRC allegations. That the CJTF-7 Inspector General periodically conduct unscheduled inspections of detention and interrogation operations providing direct feedback to the commander.

c. (U) DOCTRINE

(1) (U) Finding: Army and Joint doctrine did not directly contribute to the abuses found at Abu Ghraib. Abuses would not have occurred had doctrine been followed. Nonetheless, certain areas need to be updated, expanded or refined.

(2) (U) Recommendations:

(a) (U) That JFCOM in concert with the Army update Joint and Army publications to clearly address the concept, organization and operations of a Joint Interrogation and Debriefing Center in a future joint operational environment.

(b) (U) That the Army update interrogation operations doctrine to clarify responsibilities for interrogation techniques at both tactical and strategic levels. The ongoing revision and update of FM 34-52, Intelligence Interrogations, should clarify the roles and responsibilities of MP and MI units at centralized detention facilities.

(c) (U) That DOD assess the impact of current policies on Detention and Interrogation Operations. That DOD review the limits of authority for interrogation techniques and publish guidance that applies to all services and agencies.

d. (U) V CORPS TRANSITION TO CJTF

(1) (U) Findings:

UNCLASSIFIED

UNCLASSIFIED

(a)(U) V Corps was never adequately resourced as a CJTF. The challenge of transitioning from V Corps HQ5 to CJTF-7 without adequate personnel, equipment, and intelligence architecture, severely degraded the commander and staff during transition. Personnel shortages documented in the JMD continued to preclude operational capabilities.

(b)(U) Command and control headquarters that can perform as a Joint Task Force in a joint operational environment will be the norm for the future. This fact warrants action by supporting commands and services to resource and train JTF capable headquarters for success.

(2) (U) Recommendations:

(a)(U) That the Army expedite the development and transition of Corps-level command and control headquarters into JTF-capable organizations.

(b)(U) That the Army in concert with JFCOM institutionalize and resource the personnel and equipment needs of future JTF-capable headquarters, including the intelligence architecture of such headquarters.

e. (U) INTELLIGENCE ARCHITECTURE and INTELLIGENCE PERSONNEL RESOURCES

(1) (U) Findings:

(a)(U) Demands on the HUMINT capabilities in a counter-insurgency and in the future joint operational environment will continue to tax tactical and strategic assets. An Intelligence Fusion Center, a Joint Inter-agency Task Force and a JC2X are essential to provide seamless tactical through strategic level intelligence in a JTF headquarters.

(b)(U) Future land forces, especially the Army, need trained and experienced tactical HUMINT personnel to operate in the future Joint Operational Environment,

(2) (U) Recommendations:

(a) (U) That the Army conduct a holistic review of the CIHUMINT intelligence force structure and prioritize needs for the future joint operational environment. The review should consider the personnel, equipment and resources needed to provide a seamless intelligence capability from the tactical to the strategic level to support the combatant commander.

(b) (U) That the Army align and train HUMINT assets geographically to leverage language skills and knowledge of culture.

(c) (U) That land forces, particularly MI and MP personnel, conduct rigorous collective training to replicate the complex environment experienced in OIF and in likely future areas of conflict.

f. (U) FACILITIES

UNCLASSIFIED

UNCLASSIFIED

(1) (U) finding: Abu Ghraib detention facility was inadequate for safe and secure detention and interrogation operations. CJTF-7 lacked viable alternatives due to the depleted infrastructure in Iraq.

(2) (U) Recommendation: That the Army review the concept of detainee contingency facilities that can be rapidly deployed and established to safeguard and secure detainees, while providing necessary facilities to conduct screening and interrogations (similar to the concept of the Force Provider or Red Horse contingency facilities, where pre-fabricated buildings can be set up quickly). Adopting this recommendation would provide commanders an option for rapidly deploying and establishing detention facilities.

g. (U) OTHER GOVERNMENT AGENCIES

(1) (U) Findings:

(a) (U) Working alongside non-military organizations/agencies to jointly execute missions for our Nation, proved to be complex and demanding on military units at the tactical level. There was at least the perception that non-DOD agencies had different rules regarding interrogation and detention operations. Policies and specific limits of authority need review to ensure applicability to all organizations operating in the designated theater of operations

(b) (U) Seamless sharing of operational intelligence was hindered by lack of a fusion center that received, analyzed, and disseminated all intelligence collected by CJTF-7 units and other agencies/units outside of the CJTF-7 chain of command.

(c) (U) Proliferation of Interrogation and Counter-Resistance Technique memorandums, with specific categorization of unlawful combatants in various theaters of operations, and the inter-mingling of tactical, strategic, and other agency interrogators at the central detention facility of Abu Ghraib, provided a permissive and compromising climate for Soldiers.

(d) (U) Soldiers/Sailors/Airmen/Marines should never be put in a position that potentially puts them at risk for non-compliance with the Geneva Conventions or Laws of Land Warfare

(2) (U) Recommendations:

(a)(U) That DOD review inter-agency policies to ensure that all parties in a specific theater of operations are required to adhere to the same guidance and rules in the use of military Interrogation and Detention Facilities, including limits of authority for interrogation techniques.

(b)(U) That CENTCOM publish guidance for compliance by all agencies/organizations utilizing military detention facilities in the Iraqi theater of operation.

(c)(U) That DOD review the responsibilities for interrogations by other agencies and other agencies responsibilities to the combatant commander to provide intelligence information and support.

UNCLASSIFIED

UNCLASSIFIED

(d)(U) That DOD assess the impact of current policies and guidance on unlawful combatants in the conduct of Detention and Interrogation Operations. And, that DOD review the limits of authority for use of interrogation techniques and publish guidance that is applicable to all parties using military facilities.

h. (U) LEADERSHIP and SUCCESSES

(1) (U) Findings:

(a) (U) Leaders throughout Operation Iraqi Freedom were confronted with a complex operational environment. The speed at which leaders at all echelons adapted to this environment varied based on level of training, maturity in command, and ability to see the battlefield. The adaptability of leaders in future operational environments will be critical.

(b) (U) In Operation Iraqi Freedom, as the intelligence architecture matured and became properly equipped and organized, and close working relationships with all intelligence agencies and other OIF forces developed, there were clear successes in obtaining intelligence.

(c) (U) HUMINT management and Intelligence Fusion were essential to enable success in this complex operational environment.

(2) (U) Recommendations.

(a) (U) That rigorous leader training in our institutions, at home stations, and at the Army's Training Centers (Joint Readiness Training Center, National Training Center, Combat Maneuver Training Center, and Battle Command Training Program) continue.

(b) (U) That DOD/CENTCOM and the senior leaders of all services recognize and provide a vote of confidence to our military's leaders and Soldiers executing the OIF mission and supporting the Iraqi people.

UNCLASSIFIED

1149

SECRET//NOFORN//X1

**AR 15-6 INVESTIGATION OF THE
ABU GHRAIB DETENTION FACILITY AND
205th MILITARY INTELLIGENCE BRIGADE (U)**

**MG GEORGE R. FAY
INVESTIGATING OFFICER**

SECRET//NOFORN//X1

CLASSIFIED BY: AR 380-6
DECLASSIFY ON: OADR

SECRET//NOFORN//X1

SUBJECT: (U) AR 15-6 Investigation of the Abu Ghraib Detention Facility and
205th MI Brigade

TABLE OF CONTENTS

1. (U) Appointing Official's Instructions and Investigation Methodology	4
2. (U) Executive Summary	7
3. (U) Background and Environment	10
a. (U) Operational Environment	10
b. (U) Law, Policy, Doctrine and Training	11
(1) (U) Applicable Law	11
(2) (U) Army Regulation 190-8	14
(3) (U) Military Intelligence Doctrine and Training	15
(4) (U) Military Police Doctrine and Training	20
(5) (U) Intelligence and Interrogation Policy Development	21
(6) (U) Other Regulatory Procedural Guidance	29
4. (U) Summary of Events at Abu Ghraib	30
a. (U) Military Intelligence Task Organization and Resources	31
(1) (U) Task Organization	
(2) (U) Resources	
b. (U) Establishment of the Prison at Abu Ghraib	33
c. (U) Detention Operations and Release Procedures	34
d. (U) Establishment of Military Police Presence at Abu Ghraib	39
e. (U) Establishment of Military Intelligence Presence at Abu Ghraib	40
f. (U) Establishment, Organization, and Operation of the Joint Interrogation and Debriefing Center (JIDC)	41
g. (U) Contract Interrogators and Linguists	47
h. (U) Other Government Agencies and Abu Ghraib	52
i. (U) The Move of the 205th Military Intelligence Brigade Commander to Abu Ghraib	55
j. (U) Advisory and Training Team Deployments	57
(1) (U) MG G. Miller Visit	
(2) (U) JTF-GTMO Training Team	
(3) (U) Fort Huachuca Mobile Training Team	
k. (U) International Committee of the Red Cross (ICRC)	64
5. (U) Summary of Abuses at Abu Ghraib	68

SECRET//NOFORN//X1

1151

SECRET//NOFORN//X1

SUBJECT: (U) AR 15-6 Investigation of the Abu Ghraib Detention Facility and
205th MI Brigade

TABLE OF CONTENTS (cont)

6. (U) Findings and Recommendations	109
a. (U) Major Findings	109
b. (U) Other Findings and Recommendations	109
c. (U) Individual Responsibility for Detainee Abuse at Abu Ghraib	120
7. (U) Personnel Listing	137
8. (U) Task Force Members	138
9. (U) Acronyms	139

SECRET//NOFORN//X1

SECRET//NOFORN//X1

SUBJECT: (U) AR 15-6 Investigation of the Abu Ghraib Detention Facility and
205th MI Brigade

1. (U) Appointing Officials' Instructions and Investigative Methodology

a. (U) Appointing Officials' Instruction.

(1) (U) On 31 March 2004, LTG Ricardo S. Sanchez, Commander, Combined Joint Task Force 7 (CJTF-7), appointed MG George R. Fay as an Army Regulation (AR) 381-10 Procedure 15 Investigating Officer. LTG Sanchez determined, based upon MG Antonio Taguba's out brief of the results of an Article 15-6 investigation of the Abu Ghraib Detention Facility in Iraq, that another investigation was warranted. MG Fay was to investigate allegations that members of the 205th Military Intelligence Brigade were involved in detainee abuse at the Abu Ghraib Detention Facility.

(a) (U) MG Fay was instructed as follows: Pursuant to AR 381-10, Procedure 15, you are hereby appointed as an investigating officer to conduct an investigation in accordance with (IAW) Army Regulation (AR) 15-6 into all the relevant facts and circumstances surrounding the alleged misconduct on the part of personnel assigned and/or attached to the 205th Military Intelligence (MI) Brigade, to include civilian interrogators and/or interpreters, from 15 August 2003 to 1 February 2004 at the Abu Ghraib (AG) Detention Facility.

(b) (U) Specifically, you will investigate the following areas:

[1] (U) Whether 205th MI Brigade personnel requested, encouraged, condoned, or solicited Military Police (MP) personnel to abuse detainees at AG as preparation for interrogation operations.

[2] (U) Whether 205th MI Brigade personnel comported with established interrogation procedures and applicable laws and regulations when questioning Iraqi security internees at the Joint Interrogation and Debriefing Center.

(2) (U) The Commander, United States Central Command (CENTCOM) requested a new appointing authority and investigating officer be assigned to the investigation. On 14 June 2004, Secretary of Defense (SECDEF) Donald Rumsfeld requested the Acting Secretary of the Army (SECARMY) R.L. Brownlee assign an "officer senior to LTG Sanchez" to assume his duties as appointing authority, and a new or additional investigating officer should one be required. SECDEF provided the following additional guidance to the Acting SECARMY:

(U) The new appointing authority shall refer recommendations concerning issues at the Department of the Army level to the Department of the Army and recommendations concerning issues at the Department of Defense (DoD) level to the Department of Defense for appropriate action. The appointing authority shall refer the completed report to the Commander,

SECRET//NOFORN//X1

1153

SECRET//NOFORN//X1

SUBJECT: (U) AR 15-6 Investigation of the Abu Ghraib Detention Facility and
205th MI Brigade

United States Central Command for further action as appropriate, including forwarding to the ATSD(IO) [Assistant to the Secretary of Defense for Intelligence Oversight] in accordance with DoD Directive 5240.1-R and CJCS-I 5901.01. Matters concerning accountability, if any, should be referred by the appointing authority, without recommendation, to the appropriate level of the chain of command for disposition.

(3) (U) On 16 June 2004, Acting SECARMY Brownlee designated GEN Paul J. Kern, Commander of the US Army Materiel Command, as the new Procedure 15 appointing authority. Acting SECARMY Brownlee's instructions included the following:

(a) (U) I am designating you as the appointing authority. Major General Fay remains available to perform duties as the investigating officer. If you determine, however, after reviewing the status of the investigation, that a new or additional investigating officer is necessary, please present that request to me.

(b) (U) Upon receipt of the investigation, you will refer all recommendations concerning issues at the Department of the Army level to me and all recommendations concerning issues at the Department of Defense level to the Secretary of Defense for appropriate action. You will refer the completed report to the Commander, United States Central Command, for further action as appropriate, including forwarding to ATSD(IO) IAW DoD Directive 5240.1-R and CJCS-I 5901.01. Finally, you should refer matters concerning accountability, if any, without recommendation, to the appropriate level of the chain of command for disposition. If you determine that you need further legal resources to accomplish this mission, you should contact the Judge Advocate General.

(4) (U) On 25 June 2004, GEN Kern appointed LTG Anthony R. Jones, Deputy Commanding General, US Army Training and Doctrine Command (TRADOC), as an additional Procedure 15 investigating officer. GEN Kern's instructions to LTG Jones included the following:

(a) (U) Pursuant to AR 381-10, Procedure 15, and AR 15-6, you are hereby appointed as an investigating officer to conduct an investigation of alleged misconduct involving personnel assigned or attached to the 205th Military Intelligence Brigade at the Abu Ghraib Detention Facility. Your appointment is as an additional investigating officer. MG Fay and his investigative team are available to assist you.

(b) (U) Specifically, the purpose of the investigation is to determine the facts and to determine whether the questionable activity at Abu Ghraib is legal and is consistent with applicable policy. In LTG Sanchez's 31 March 2004 appointment letter to MG Fay, which I have adopted, he specified three areas into which the investigation was to look: whether the 205th

SECRET//NOFORN//X1

SECRET//NOFORN//X1

SUBJECT: (U) AR 15-6 Investigation of the Abu Ghraib Detention Facility and
205th MI Brigade

Military Intelligence Brigade had been involved in Military Police detainee abuse at Abu Ghraib; whether 205th Military Intelligence Brigade personnel complied with established procedures, regulations, and laws when questioning internees at the Joint Interrogation and Debriefing Center; and the facts behind several identified sworn statements. In addition, your investigation should determine whether organizations or personnel higher in the chain of command of the 205th Military Intelligence Brigade were involved directly or indirectly in any questionable activities regarding alleged detainee abuse at Abu Ghraib.

b. (U) Investigative Methodology.

(1) (U) The investigative team conducted a comprehensive and exhaustive review of available background documents and statements pertaining to the operations of the 205th Military Intelligence (MI) Brigade (205 MI BDE) at Abu Ghraib from a wide variety of sources, to include all previous investigations. Where possible, coordination was established with other ongoing investigations of the same nature.

(2) (U) Over 170 personnel were interviewed (some multiple times) during the course of the investigation (Reference Annex B, Appendix 1). These interviews included personnel assigned or attached to the 205 MI BDE, the 800th Military Police (MP) Brigade (800 MP BDE), CJTF-7, Joint Task Force Guantanamo (JTF-GTMO), 28th Combat Support Hospital (CSH), the United States Army Intelligence Center (USAIC), the United States Navy, Titan Corporation, CACI International, Inc., and three detainees at Abu Ghraib. Written sworn statements were prepared as a result of these interviews. Several personnel invoked their rights under Article 31, Uniform Code of Military Justice (UCMJ) and the 5th Amendment of the US Constitution. In these cases and in cases where no sworn statements were collected, Memoranda for Record (MFR) were prepared to describe the nature of and information addressed in the interview.

(3) (U) Over 9,000 documents were collected, catalogued and archived into a database. Advanced analytic tools were used to organize, collate, and analyze this data as well as all collected interview data. Other analytical tools were used to prepare graphic representations of the data.

(4) (U) The investigative team consisted of 26 personnel to include investigators, analysts, subject matter experts and legal advisors.

SECRET//NOFORN//X1

SECRET//NOFORN//X1

SUBJECT: (U) AR 15-6 Investigation of the Abu Ghraib Detention Facility and
205th MI Brigade

2. (U) Executive Summary

a. (U) Background.

(1) (U) This investigation was ordered initially by LTG Ricardo S. Sanchez, Commander, CJTF-7. LTG Sanchez appointed MG George R. Fay as investigating officer under the provisions of AR 381-10. MG Fay was appointed to investigate allegations that members of the 205 MI BDE were involved in detainee abuse at the Abu Ghraib Detention Facility. Specifically, he was to determine whether 205 MI BDE personnel requested, encouraged, condoned, or solicited MP personnel to abuse detainees and whether MI personnel comported with established interrogation procedures and applicable laws and regulations. The investigative team conducted a comprehensive review of all available background documents and statements pertaining to Abu Ghraib from a wide variety of sources. Over 170 persons were interviewed concerning their knowledge of interrogation and detention operations at Abu Ghraib and/or their knowledge of and involvement in detainee abuse. On 16 June 2004, GEN Paul J. Kern, Commander, US Army Materiel Command (AMC), was appointed as the new Procedure 15 appointing authority. On 25 June 2004, GEN Kern appointed LTG Jones, Deputy Commanding General, TRADOC, as an additional Procedure 15 investigating officer. MG Fay was retained as an investigating officer.

(2) (U) This investigation identified forty-four (44) alleged instances or events of detainee abuse committed by MP and MI Soldiers, as well as civilian contractors. On sixteen (16) of these occasions, abuse by the MP Soldiers was, or was alleged to have been, requested, encouraged, condoned, or solicited by MI personnel. The abuse, however, was directed on an individual basis and never officially sanctioned or approved. MI solicitation of MP abuse included the use of isolation with sensory deprivation, removal of clothing and humiliation, the use of dogs as an interrogation tool to induce fear, and physical abuse. In eleven (11) instances, MI personnel were found to be directly involved in the abuse. MI personnel were also found not to have fully comported with established interrogation procedures and applicable laws and regulations. Theater Interrogation and Counter-Resistance Policies (ICRP) were found to be poorly defined, and changed several times. As a result, interrogation activities sometimes crossed into abusive activity.

(3) (U) This investigation found that certain individuals committed offenses in violation of international and US law to include the Geneva Conventions and the UCMJ and violated Army Values. Leaders in key positions failed properly to supervise the interrogation operations at Abu Ghraib and failed to understand the dynamics created at Abu Ghraib. Leaders also failed to react appropriately to those instances where detainee abuse was reported, either by other service members, contractors, or by the International Committee of the Red Cross (ICRC). Fifty-four (54) MI, MP, and Medical Soldiers, and civilian contractors were found to have some degree of

SECRET//NOFORN//X1

SECRET//NOFORN//X1

SUBJECT: (U) AR 15-6 Investigation of the Abu Ghraib Detention Facility and
205th MI Brigade

responsibility or complicity in the abuses that occurred at Abu Ghraib. Twenty-seven (27) were cited in this report for some degree of culpability and seventeen (17) were cited for misunderstanding of policy, regulation or law. Three (3) MI Soldiers, who had previously received punishment under UCMJ, were recommended for additional investigation. Seven (7) MP Soldier identified in the MG Taguba Report and currently under criminal investigation and/or charges are also central figures in this investigation and are included in the above numbers. One (1) person cited in the MG Taguba Report was exonerated.

(4) (U) Looking beyond personal responsibility, leader responsibility and command responsibility, systemic problems and issues also contributed to the volatile environment in which the abuse occurred. These systemic problems included: inadequate interrogation doctrine and training, an acute shortage of MP and MI Soldiers, the lack of clear lines of responsibility between the MP and MI chains of command, the lack of a clear interrogation policy for the Iraq Campaign, and intense pressure felt by the personnel on the ground to produce actionable intelligence from detainees. Twenty-four (24) additional findings and two (2) observations regarding systemic failures are included in the final investigative report. These findings ranged from doctrine and policy concerns, to leadership and command and control issues, to resource and training issues.

b. (U) Problems: Doctrine, Policy, Training, Organization, and Other Government Agencies.

(1) (U) Inadequacy of doctrine for detention operations and interrogation operations was a contributing factor to the situations that occurred at Abu Ghraib. The Army's capstone doctrine for the conduct of interrogation operations is Field Manual (FM) 34-52, Intelligence Interrogation, dated September 1992. Non-doctrinal approaches, techniques, and practices were developed and approved for use in Afghanistan and GTMO as part of the Global War on Terrorism (GWOT). These techniques, approaches, and practices became confused at Abu Ghraib and were implemented without proper authorities or safeguards. Soldiers were not trained on non-doctrinal interrogation techniques such as sleep adjustment, isolation, and the use of dogs. Many interrogators and personnel overseeing interrogation operations at Abu Ghraib had prior exposure to or experience in GTMO or Afghanistan. Concepts for the non-doctrinal, non field-manual approaches and practices came from documents and personnel in GTMO and Afghanistan. By October 2003, interrogation policy in Iraq had changed three times in less than thirty days and it became very confusing as to what techniques could be employed and at what level non-doctrinal approaches had to be approved.

(2) (U) MP personnel and MI personnel operated under different and often incompatible rules for treatment of detainees. The military police referenced DoD-wide regulatory and procedural guidance that clashed with the theater interrogation and counter-resistance policies that the military intelligence interrogators followed. Further, it appeared that neither group knew

SECRET//NOFORN//X1

SECRET//NOFORN//X1

SUBJECT: (U) AR 15-6 Investigation of the Abu Ghraib Detention Facility and
205th MI Brigade

or understood the limits imposed by the other's regulatory or procedural guidance concerning the treatment of detainees, resulting in predictable tension and confusion. This confusion contributed to abusive interrogation practices at Abu Ghraib. Safeguards to ensure compliance and to protect against abuse also failed due to confusion about the policies and the leadership's failure to monitor operations adequately.

(3) (U) By December 2003, the JIDC at Abu Ghraib had a total of approximately 160 personnel with 45 interrogators and 18 linguists/translators assigned to conduct interrogation operations. These personnel were from six different MI battalions and groups – the 519 MI BN, 323 MI BN, 325 MI BN, 470 MI GP, the 66th MI GP, the 500 MI GP. To complicate matters, interrogators from a US Army Intelligence Center and School, Mobile Training Team (MTT) consisting of analysts and interrogators, and three interrogation teams consisting of six personnel from GTMO, came to Abu Ghraib to assist in improving interrogation operations. Additionally, contract interrogators from CACI and contract linguists from Titan were hired in an attempt to address shortfalls. The JIDC was created in a very short time period with parts and pieces of various units. It lacked unit integrity, and this lack was a fatal flaw.

(4) (U) The term Other Government Agencies (OGA) most commonly referred to the Central Intelligence Agency (CIA). The CIA conducted unilateral and joint interrogation operations at Abu Ghraib. The CIA's detention and interrogation practices contributed to a loss of accountability and abuse at Abu Ghraib. No memorandum of understanding existed on the subject interrogation operations between the CIA and CJTF-7, and local CIA officers convinced military leaders that they should be allowed to operate outside the established local rules and procedures. CIA detainees in Abu Ghraib, known locally as "Ghost Detainees," were not accounted for in the detention system. With these detainees unidentified or unaccounted for, detention operations at large were impacted because personnel at the operations level were uncertain how to report or classify detainees.

c. (U) Detainee Abuse at Abu Ghraib.

(1) (U) Physical and sexual abuses of detainees at Abu Ghraib were by far the most serious. The abuses spanned from direct physical assault, such as delivering head blows rendering detainees unconscious, to sexual posing and forced participation in group masturbation. At the extremes were the death of a detainee in OGA custody, an alleged rape committed by a US translator and observed by a female Soldier, and the alleged sexual assault of a female detainee. These abuses are, without question, criminal. They were perpetrated or witnessed by individuals or small groups. Such abuse can not be directly tied to a systemic US approach to torture or approved treatment of detainees. The MPs being prosecuted claim their actions came at the direction of MI. Although self-serving, these claims do have some basis in fact. The environment created at Abu Ghraib contributed to the occurrence of such abuse and the fact that

SECRET//NOFORN//X1

SECRET//NOFORN//X1

SUBJECT: (U) AR 15-6 Investigation of the Abu Ghraib Detention Facility and
205th MI Brigade

it remained undiscovered by higher authority for a long period of time. What started as nakedness and humiliation, stress and physical training (exercise), carried over into sexual and physical assaults by a small group of morally corrupt and unsupervised Soldiers and civilians.

(2) (U) Abusing detainees with dogs started almost immediately after the dogs arrived at Abu Ghraib on 20 November 2003. By that date, abuses of detainees was already occurring and the addition of dogs was just one more device. Dog Teams were brought to Abu Ghraib as a result of recommendations from MG G. Miller's assessment team from GTMO. MG G. Miller recommended dogs as beneficial for detainee custody and control issues. Interrogations at Abu Ghraib, however, were influenced by several documents that spoke of exploiting the Arab fear of dogs. The use of dogs in interrogations to "fear up" detainees was utilized without proper authorization.

(3) (U) The use of nudity as an interrogation technique or incentive to maintain the cooperation of detainees was not a technique developed at Abu Ghraib, but rather a technique which was imported and can be traced through Afghanistan and GTMO. As interrogation operations in Iraq began to take form, it was often the same personnel who had operated and deployed in other theaters and in support of GWOT, who were called upon to establish and conduct interrogation operations in Abu Ghraib. The lines of authority and the prior legal opinions blurred. They simply carried forward the use of nudity into the Iraqi theater of operations. The use of clothing as an incentive (nudity) is significant in that it likely contributed to an escalating "de-humanization" of the detainees and set the stage for additional and more severe abuses to occur.

(4) (U) There was significant confusion by both MI and MPs between the definitions of "isolation" and "segregation." LTG Sanchez approved the extended use of isolation on several occasions, intending for the detainee to be kept apart, without communication with their fellow detainees. His intent appeared to be the segregation of specific detainees. The technique employed in several instances was not, however, segregation but rather isolation - the complete removal from outside contact other than required care and feeding by MP guards and interrogation by MI. Use of isolation rooms in the Abu Ghraib Hard Site was not closely controlled or monitored. Lacking proper training, clear guidance, or experience in this technique, both MP and MI stretched the bounds into further abuse; sensory deprivation and unsafe or unhealthy living conditions. Detainees were sometimes placed in excessively cold or hot cells with limited or poor ventilation and no light.

3. (U) Background and Environment.

a. (U) Operational Environment.

SECRET//NOFORN//X1

SECRET//NOFORN//X1

SUBJECT: (U) AR 15-6 Investigation of the Abu Ghraib Detention Facility and
205th MI Brigade

(1) (U) The Global War on Terrorism began in earnest on 11 September 2001 (9/11). Soon after the 9/11 attacks, American forces entered Afghanistan to destroy the primary operating and training base of Al Qaida. Prisoners collected in these and other global counter-terrorist operations were transferred to Guantanamo Naval Base, Cuba. Two Task Forces were formed at JTF-GTMO to manage intelligence collection operations with the newly captured prisoners. Military and civilian interrogators, counterintelligence agents, analysts, and other intelligence personnel from a variety of services and agencies manned the task forces and exploited the captured personnel for information.

(2) (U) US and coalition partners attacked Iraq on 20 March 2003 and soon after toppled Saddam Hussein's regime. The Iraq conflict transitioned quickly and unexpectedly to an insurgency environment. Coalition forces began capturing and interrogating alleged insurgents. Abu Ghraib prison, opened after the fall of Saddam to house criminals, was soon used for collecting and interrogating insurgents and other persons of intelligence interest. The unit responsible for managing Abu Ghraib interrogations was the 205 MI BDE.

b. (U) Law, Policy, Doctrine and Training.

(1) (U) Applicable Law.

(a) (U) Military Order of November 13th 2001 – Detention, Treatment and Trial of Certain Non-Citizens in the War Against Terrorism (Reference Annex J, Appendix 1).

(b) (U) Geneva Convention (IV) Relative to the Protection of Civilian Persons in Time of War, 12 August 1949 (Reference Annex J, Appendix 5).

(c) (U) AR 190-8 / OPNAVINST 3461.6 / AFJI 31-302/MCO 3461.1, Enemy Prisoners of War, Retained Personnel, Civilian Internees and other Detainees, 1 October 1997 (Reference Annex M, Appendix 2).

(d) (U) FM 34-52, Intelligence Interrogation, 28 September 1992 (Reference Annex M, Appendix 3).

(e) (U) Classification of Detainees. The overwhelming evidence in this investigation shows that most "detainees" at Abu Ghraib were "civilian internees." Therefore, this discussion will focus on "civilian internees."

[1] (U) Detainee. AR 190-8 defines a detainee as any person captured or otherwise detained by an armed force. By this definition, a detainee could be an Enemy Prisoner of War (EPW), a Retained Person, such as a doctor or chaplain, or a Civilian Internee. The term

SECRET//NOFORN//X1

SECRET//NOFORN//X1

SUBJECT: (U) AR 15-6 Investigation of the Abu Ghraib Detention Facility and
205th MI Brigade

“detainee” is a generic one with no specific implied rights or protections being afforded to the individual; however, it is almost exclusively used by the Soldiers and other individuals interviewed in this investigation to refer to the individuals interned at Abu Ghraib. In order to understand the rights and protections that need to be provided to a “detainee,” further classification is necessary.

[2] (U) Civilian Internee. Using Geneva Convention IV (GC IV), Article 78, as further defined by AR 190-8, a “Civilian Internee” is someone who is interned during armed conflict or occupation for security reasons or for protection or because he has committed an offense against the detaining power. (Reference Annex H, Appendix 1, FRAGO 749 to CJTF-7 OPOD 03-036). The overwhelming evidence in this investigation shows that all “detainees” at Abu Ghraib were civilian internees. Within the confinement facility, however, there were further sub-classifications that were used, to include criminal detainee, security internee, and MI Hold.

[a] (U) Criminal Detainee. A person detained because he/she is reasonably suspected of having committed a crime against Iraqi Nationals or Iraqi property or a crime not related to the coalition force mission (Reference Annex H, Appendix 1, FRAGO 749 to CJTF-7 OPOD 03-036).

[b] (U) Security Internee. Civilians interned during conflict or occupation for their own protection or because they pose a threat to the security of coalition forces, or its mission, or are of intelligence value. This includes persons detained for committing offenses (including attempts) against coalition forces (or previous coalition forces), members of the Provisional Government, Non-Government Organizations, state infrastructure, or any person accused of committing war crimes or crimes against humanity. Security internees are a subset of civilian internees (Reference Annex H, Appendix 1, FRAGO 749 to CJTF-7 OPOD 03-036).

[c] (U) MI Hold. A directive to hold and not release a detainee/internee in the custody of the Coalition Forces, issued by a member or agent of a US Military Intelligence Organization (Reference Annex H, Appendix 1, FRAGO 749 to CJTF-7 OPOD 03-036).

[d] (U) Most detainees located within Abu Ghraib, to include those in Tier 1A and 1B (Reference Annex F, Appendix 1, Abu Ghraib Overhead with Organizational Layout), were Civilian Internees and therefore, entitled to protections under GC IV. In addition to applicable international laws, ARs, and the FMs on Intelligence Interrogations further clarify US Policy regarding the protections afforded Civilian Internees.

(f) (U) Geneva Convention Relative to the Protection of Civilians in Time of War. GC IV provides protections for civilians in time of war. The US is bound by the Geneva Conventions; therefore, any individual acting on behalf of the US during an armed conflict is

SECRET//NOFORN//X1

SECRET//NOFORN//X1

SUBJECT: (U) AR 15-6 Investigation of the Abu Ghraib Detention Facility and
205th MI Brigade

also bound by Geneva Conventions. This includes not only members of the armed forces, but also civilians who accompany or work with the US Armed Forces. The following are some relevant articles to the discussion on detainee abuse:

[1] (U) Article 5. Where in the territory of a Party to the conflict, the latter is satisfied that an individual protected person is definitely suspected of or engaged in activities hostile to the security of the State, such individual person shall not be entitled to claim such rights and privileges under the present Conventions as would, if exercised in the favor of such individual person, be prejudicial to the security of such State. Where in occupied territory an individual protected person is detained as a spy or saboteur, or as a person under definite suspicion of activity hostile to the security of the Occupying Power, such person shall, in those cases where absolute military security so requires, be regarded as having forfeited rights of communication under the present Conventions. In each case, such persons shall nevertheless be treated with humanity and, in case of trial, shall not be deprived of the rights of fair and regular trial prescribed by the present [convention].

[2] (U) Article 27. Protected persons are entitled, in all circumstances, to respect for their persons, their honor, their family rights, their religious convictions and practices, and their manner and customs. They shall at all times be humanely treated, and shall be protected against all acts of violence or threats thereof and against insults and public curiosity.

[3] (U) Article 31. No physical or moral coercion shall be exercised against protected persons, in particular to obtain information from them or from third parties.

[4] (U) Article 32. The [Parties to the Convention] agree that each of them is prohibited from taking any measure of such a character as to cause the physical suffering or extermination of protected persons in their hands. This prohibition applies not only to murder, torture, corporal punishments, mutilation and medical and scientific experiments not necessitated by the medical treatment of a protected person, but also to any other measures of brutality whether applied by civilian or military agents.

[5] (U) Article 37. Protected persons who are confined pending proceedings or serving a sentence involving loss of liberty, shall during their confinement be humanely treated.

[6] (U) Article 100. The disciplinary regime in places of internment shall be consistent with humanitarian principles, and shall in no circumstances include regulation imposing on internees any physical exertion dangerous to their health or involving physical or moral victimization. Identification by tattooing or imprinting signs on the body is prohibited. In particular, prolonged standing and roll-calls, punishment drills, military drill and maneuver, or the reduction of food rations, are prohibited.

SECRET//NOFORN//X1

SECRET//NOFORN//X1

SUBJECT: (U) AR 15-6 Investigation of the Abu Ghraib Detention Facility and
205th MI Brigade

[7] (U) Article 143. Representatives or delegates of the Protecting Powers shall have permission to go to all places where protected persons are, particularly to places of internment, detention and work. They shall have access to all premises occupied by protected persons and shall be able to interview the latter without witnesses, personally or through an interpreter. Such visits may not be prohibited except for reasons of military imperative, and then only as an exceptional and temporary measure. Their duration and frequency shall not be restricted. Such representatives and delegates shall have full liberty to select the places they wish to visit. The Detaining or Occupying Power, the Protecting Power, and when occasion arises the Power of origin of the persons to be visited, may agree that compatriots of the internees shall be permitted to participate in the visits. The delegates of the International Committee of the Red Cross shall also enjoy the above prerogatives. The appointment of such delegates shall be submitted for the approval of the Power governing the territories where they will carry out their duties.

(2) (U) AR 190-8, Enemy Prisoners of War, Retained Personnel, Civilian Internees and other Detainees is a joint publication between all services of the Armed Forces (Reference Annex M, Appendix 2).

(a) (U) US Policy Overview. The regulation (Reference Annex M, Appendix 2, AR 190-8, Paragraph 1-5) sets out US Policy stating that "US policy, relative to the treatment of EPW, Civilian Internees and RP in the custody of the US Armed Forces, is as follows: All persons captured, detained, interned, or otherwise held in US Armed Forces custody during the course of conflict will be given humanitarian care and treatment from the moment they fall into the hands of the US forces until final release and repatriation." The regulation further defines this policy.

(b) (U) Inhumane Treatment. Specifically, inhumane treatment of detainees is prohibited and is considered a serious and punishable offense under international law and the UCMJ. The following acts are prohibited: murder, torture, corporal punishment, mutilation, the taking of hostages, sensory deprivation, collective punishment, execution without trial, and all cruel and degrading treatment. (Reference Annex M, Appendix 2, AR 190-8, Paragraph 1-5(b)).

(c) (U) Protection from Certain Acts. All detainees will be protected against all acts of violence to include rape, forced prostitution, assault and theft, insults, public curiosity, bodily injury, and reprisals of any kind. (Reference Annex M, Appendix 2, AR 190-8, Paragraph 1-5(c)). This is further reinforced in FM 34-52 (Reference Annex M, Appendix 3), which states that the Geneva Conventions and US policy expressly prohibit acts of violence or intimidation, including physical or mental torture, threats, insults, or exposure to inhumane treatment as a means of or aid to interrogation.

SECRET//NOFORN//X1

SECRET//NOFORN//X1

SUBJECT: (U) AR 15-6 Investigation of the Abu Ghraib Detention Facility and
205th MI Brigade

(d) (U) Photographs. Photographs of detainees are strictly prohibited except for internal administrative purposes of the confinement facility. (Reference Annex M, Appendix 2, AR 190-8, Paragraph 1-5(d)).

(e) (U) Physical torture or moral coercion. No form of physical or moral coercion will be exercised against the Civilian Internee. (Reference Annex M, Appendix 2, AR 190-8, Paragraph 1-5(a)(1)).

(f) (U) At all times, the Civilian Internee will be humanely treated and protected against all acts of violence or threats and insults and public curiosity. The Civilian Internee will be especially protected against all acts of violence, insults, public curiosity, bodily injury, reprisals of any kind, sexual attacks such as rape, forced prostitution, or any form of indecent assault. (Reference Annex M, Appendix 2, AR 190-8, Paragraph 1-5(a)(2) & (3)).

(3) (U) Military Intelligence Doctrine and Training.

(a) (U) Doctrine.

[1] (U) The Army's capstone doctrine for the conduct of interrogation operations is FM 34-52, Intelligence Interrogation, dated September, 1992. This doctrine provides an adequate basis for the training of interrogators at the Soldier level (e.g., in the art of tactical interrogation and the Geneva Conventions); however, it is out of date with respect to the management and conduct of detainee operations. Joint Doctrine on the conduct of detainee operations is sparse even though the Army has operated JIDCs since 1989 in Operation JUST CAUSE, and because the Army is normally tasked by the Joint Force Commander to establish and manage EPW/Detainee operations for the deployed force (Reference Annex M, Appendix 1, APPENDIX G-3, Joint Publication 2-01, Joint Intelligence Support to Military Operations). National level doctrine, in the form of a Defense Intelligence Agency Manual (DIAM), also contains very little doctrinal basis for the conduct and management of joint interrogation operations. A critical doctrinal gap at the joint and service level is the role of national level agencies (e.g., other governmental agencies [OGA]) in detainee operations to include appropriate protocols for sharing valuable intelligence assets. The Center for Army Lessons Learned (CALL) reported the following in a recent assessment of Operation Iraqi Freedom detainee and interrogation operations (Reference Annex C, Appendix 5):

MP and MI doctrine at division and below must be modified for stability operations and support operations to reflect the need for long-term detention facilities and interrogation of captives at the tactical level.

SECRET//NOFORN//X1

SECRET//NOFORN//X1

SUBJECT: (U) AR 15-6 Investigation of the Abu Ghraib Detention Facility and
205th MI Brigade

[2] (U) It is possible that some of the unauthorized interrogation techniques employed in Iraq may have been introduced through the use of an outdated training manual (FM 34-52 dated 1987 vice FM 34-52 dated 1992). The superseded version (FM 34-52, dated 1987) has been used at various locations in OIF. In a prior AR 15-6 investigation of Camp Cropper (Reference Annex C, Appendix 2), the 1987 version was again used as the reference (Reference Annex M, Appendix 3). On 9 June 2004, CJTF-7 published an email (Reference Annex L, Appendix 4, email) that indicated the May 1987 version was used as CJTF-7's primary reference. The section encapsulated below from the 1987 version has been removed from the 1992 version of FM 34-52. To the untrained, the reference in the outdated version could appear as a license for the interrogator to go beyond the current doctrine as established in the current FM 34-52. The 1987 version suggests the interrogator controls lighting, heating, and configuration of the interrogation room, as well as the food, shelter, and clothing given to the source. The section from the 1987 version that could be misunderstood is from Chapter 3 and reads as follows:

FM 34-52 (1987) Chapter 3, Establish and Maintain Control. The interrogator should appear to be the one who controls all aspects of the interrogation to include the lighting, heating, and configuration of the interrogation room, as well as the food, shelter, and clothing given to the source. The interrogator must always be in control, he must act quickly and firmly. However, everything that he says and does must be within the limits of the Geneva and Hague Conventions, as well as the standards of conduct outlined in the UCMJ.

[3] (U) Doctrine provides the foundation for Army operations. A lack of doctrine in the conduct of non-conventional interrogation and detainee operations was a contributing factor to the abuses at Abu Ghraib.

(b) (U) Training

[1] (U) Formal US Army interrogation training is conducted at the Soldier level, primarily as part of a Soldier's Initial Entry Training (IET). There is no formal advanced interrogation training in the US Army. Little, if any, formal training is provided to MI leaders and supervisors (Commissioned Officers, Warrant Officers, and Non-Commissioned Officers) in the management of interrogation and detainee operations. These skills can only be developed in the unit environment through assignments to an interrogation unit, involvement in interrogation training exercises, or on deployments. Unfortunately, unit training and exercises have become increasingly difficult to conduct due to the high pace of deployments of interrogation personnel

SECRET//NOFORN//X1

SECRET//NOFORN//X1

SUBJECT: (U) AR 15-6 Investigation of the Abu Ghraib Detention Facility and
205th MI Brigade

and units. With very few exceptions, combined MI and MP training on the conduct of detainee operations is non-existent.

[2] (U) The IET course at the USAIC, Fort Huachuca, AZ, provides a 16.5 week course of instruction. The course consists of 758.2 hours of academic training time that includes collection prioritization, screening, planning and preparation, approaches, questioning, termination of interrogations, and report writing in the classroom and practical exercise environments. The course focuses on the conduct of tactical interrogations in conventional war. Each student receives eight hours of classroom training on AR 381-10, Army Intelligence Activities (Reference Annex M, Appendix 2) and FM 27-10, Law of Land Warfare (Reference Annex M, Appendix 3) and 184 hours of practical exercise. The student's understanding of the Geneva Conventions and Law of Land Warfare is continually evaluated as a critical component. If at any time during an exercise, the student violates the Geneva Conventions, they will fail the exercise. A failure does not eliminate the student from the course. Students are generally given the chance to recycle to the next class; however, egregious violations could result in dismissal from the course.

[3] (U) The reserve components use the same interrogator program of instruction as does the active component. They are exposed to the same classes and levels of instruction. Like the active component, the reserve components' training opportunities prior to deployment in recent years have been minimal, if any. Those slated for deployment to the JTF-GTMO attend the Intelligence Support to Counter Terrorism (ISCT) Course.

[4] (U) Army Regulations require interrogators to undergo refresher training on the Geneva Conventions annually. Units are also expected to conduct follow-up training for Soldiers to maintain and improve their interrogation skills. This becomes difficult given that Soldiers fresh from the basic interrogation course are deployed almost as soon as they arrive to their unit of assignment. This leaves little, if any, time to conduct that follow-on training with their unit to hone the skills they have learned in school. In addition to the unit deployments, the individual interrogators find themselves deployed to a wide variety of global engagements in a temporary duty status—not with their units of assignments. It is not uncommon for an individual to be deployed two or three times in the course of a year (e.g., the Balkans, Cuba [JTF-GTMO], Afghanistan, Iraq, or in support of Special Operations Forces [SOF]).

[5] (U) There is no formal advanced interrogation training in the US Army. The DoD manages a Strategic Debriefing Course for all services. While some of the skills are similar, the Strategic Debriefing Course is not an advanced interrogation course. Further, only interrogators being assigned to strategic debriefing assignments are authorized to attend this course. This prevents the tactical interrogator, the operator at Abu Ghraib, from further developing skills. Junior NCOs receive only limited interrogation-related training during his or

SECRET//NOFORN//X1

SECRET//NOFORN//X1

SUBJECT: (U) AR 15-6 Investigation of the Abu Ghraib Detention Facility and
205th MI Brigade

her advanced NCO courses--the Basic Non-Commissioned Officers Course (BNCOC) and the Advanced Non-commissioned Officer's Course (ANCOC). This limited training is restricted to the management of interrogation operations. The amount of time spent on the Geneva Conventions training during either of these courses is minimal. Officers receive limited training in interrogation or interrogation management in their entry level and advanced level courses. Like BNCOC and ANCOC, this training is focused on management and not the intricacies of interrogation operations or the legal restrictions applicable to interrogation operations.

[6] (U) Very little training is available or conducted to train command and staff elements on the conduct, direction, and oversight of interrogation operations. To address a portion of this shortfall, USAIC is standing up a course to teach the management of Human Intelligence to MI officers. A pilot course is scheduled and is designed to prepare the intelligence staffs (G2, S2) of a deploying Army Division with the capability to synchronize, coordinate, manage and de-conflict Counterintelligence and Human Intelligence (HUMINT) operations within the division's area of responsibility.

[7] (U) Most interrogator training that occurred at Abu Ghraib was on-the-job-training. The JIDC at Abu Ghraib conducted Interrogation Rules of Engagement (IROE) and interrogation operations training. The fast paced and austere environment limited the effectiveness of any training. After mid-September 2003, all Soldiers assigned to Abu Ghraib had to read a memorandum titled IROE, acknowledging they understood the ICRP, and sign a confirmation sheet indicating they had read and understood the ICRP. Most Soldiers have confirmed they received training on the IROE. See attached CJTF-7 IROE standard signature sheet (Reference Annex J, Appendix 4) to view an example.

[8] (U) MG G. Miller led an assessment team to Abu Ghraib in early September 2003. This was followed by a training team from 2 October - 2 December 2003. There is no indication that the training provided by the JTF-GTMO Team led to any new violations of the Geneva Conventions and the law of land warfare. Training focused on screening, the use of pocket litter during interrogations, prioritization of detainees, planning and preparation, approaches, questioning, interpreter control, deception detection, reporting, automation, and interrogation booths. The training provided at Abu Ghraib did not identify the abuses that were ongoing as violations of regulations or law, nor did it clarify issues involving detainee abuse reporting.

[9] (U) Interrogators learn as part of their training that the MPs provide the security for and run detention operations at the Collection Points (CPs), Corps Holding Areas (CHAs), and Internment/Resettlement (IR) facilities. The interrogator's mission is only to collect intelligence from prisoners or detainees. Interaction with the MPs is encouraged to take advantage of any observations the MPs/guards might have concerning a particular prisoner or

SECRET//NOFORN//X1

~~SECRET//NOFORN//X1~~

SUBJECT: (U) AR 15-6 Investigation of the Abu Ghraib Detention Facility and
205th MI Brigade

detainee. While the USAIC includes this in the interrogator's training, very little time is spent training MI/MP detention operations. In the past, the Army conducted large EPW/Detainee exercises (the Gold Sword and Silver Sword series) that provided much of the training critical to MPs' and Interrogators' understanding of their respective roles and responsibilities. These exercises were discontinued in the mid 1990s due to frequent deployments and force structure reductions, eliminating an excellent source of interoperability training. The increase in op-tempo since 9/11 has further exacerbated the unit training and exercise problem.

[10] (U) Contract Training.

[a] (U) The US Army employs contract linguists/translators and contract interrogators in military operations. Some IET is provided to familiarize military interrogators in the conduct of interrogations using translators. No training is conducted at any level (enlisted, NCO, Warrant Officer, or Officer) on the employment of contract interrogators in military operations. The use of contract interrogators and linguists at Abu Ghraib was problematic (See paragraph 4.g.) from a variety of perspectives. JIDC interrogators, analysts, and leaders were unprepared for the arrival of contract interrogators and had no training to fall back on in the management, control, and discipline of these personnel.

[b] (U) No doctrine exists to guide interrogators and their intelligence leaders (NCO, Warrant Officer, and Officer) in the contract management or command and control of contractors in a wartime environment. These interrogators and leaders faced numerous issues involving contract management: roles and responsibilities of JIDC personnel with respect to contractors; roles, relationships, and responsibilities of contract linguists and contract interrogators with military personnel; and the methods of disciplining contractor personnel. All of these need to be addressed in future interrogation and interrogation management training.

[11] (U) Soldier interrogation training is adequate with respect to interrogation techniques and procedures for conventional warfare. It is far less suited to the realities of the GWOT and Stability and Support Operations (SASO) and contract management. Despite the emphasis on the Geneva Conventions, it is clear from the results at Abu Ghraib (and elsewhere in operations in support of the GWOT) that Soldiers on the ground are confused about how they apply the Geneva Conventions and whether they have a duty to report violations of the conventions. Most Abu Ghraib interrogators performed their duties in a satisfactory manner without incident or violation of training standards. Some interrogators (See paragraph 5.c.- 5.h., below), however, violated training standards in the performance of selected interrogations. Army training at USAIC never included training on interrogation techniques using sleep adjustment, isolation, segregation, environmental adjustment, dietary manipulation, the use of military working dogs, or the removal of clothing. These techniques were introduced to selected interrogators who worked at Abu Ghraib from sources other than official Army training.

~~SECRET//NOFORN//X1~~

SECRET//NOFORN//X1

SUBJECT: (U) AR 15-6 Investigation of the Abu Ghraib Detention Facility and
205th MI Brigade

(4) (U) Military Police Doctrine and Training

(a) (U) DoD Directives 2310.1, DoD Program for Enemy Prisoners of War and Other Detainees, and 5100.77, DoD Law of War Program, require that the US military services comply with the principles, spirit, and intent of international laws of war, that the DoD observes and enforces the US obligations under the laws of war, that personnel know the laws of war obligations, and that personnel promptly report incidents violating the laws of war and that the incidents be thoroughly investigated.

(b) (U) AR 190-8, "Enemy Prisoner of War, Retained Personnel Civilian Internees and other Detainees," is a multi-service policy that incorporates the directives from the DoD publications above. The regulation addresses the military police treatment of civilian internees, and directs that:

- No physical or moral coercion be used
- Internees be treated with respect for their person, honor, manner, and customs
- Internees be protected against violence, insults, public curiosity, bodily injury, or any form of indecent assault

It specifically prohibits:

- Measures causing physical suffering, to include corporal punishment, and other measures of brutality

It specifies that disciplinary measures NOT:

- Be inhumane, brutal, or dangerous to health
- Include imprisonment in a place without daylight

The authorized disciplinary punishments include:

- Discontinuance of privileges granted over and above the treatment provided for by regulation
- Confinement, not to exceed 30 consecutive days

(Reference Annex M, Appendix 2, AR 190-8)

(c) (U) AR 190-12, Military Working Dog Program, notes that military police may potentially use dogs for EPW control, but limits their use against people to instances when the

SECRET//NOFORN//X1

1169

SECRET//NOFORN//X1

SUBJECT: (U) AR 15-6 Investigation of the Abu Ghraib Detention Facility and
205th MI Brigade

responsible commander determines it absolutely necessary and there have been reasonable efforts to use all lesser means of force. (Reference Annex M, Appendix 2, AR 190-12)

(d) (U) Procedural guidance, found in FM 3-19.40 and the MP Standard Operating Procedure (SOP) for Abu Ghraib (400th MP BN SOP for Camp Vigilant Detention Center), consistently follow directly from the DoD directives and the applicable ARs. The procedural guidance provides military police clear-cut guidance for permissible and impermissible practices during Internment Operations. (Reference Annex M, Appendix 3, FM 3-19.40; Annex J, Appendix 4, 400 MP BN SOP Camp Vigilant Detention Center)

(5) (U) Intelligence and Interrogation Policy Development.

(a) (U) National Policy.

(1) (U) US forces and intelligence officials deployed to Afghanistan and elsewhere to conduct military operations pursuant to GWOT. Specific regulatory or procedural guidance concerning either "humane" treatment or "abuse" was not available in the context of GWOT and the recently promulgated national policies. Military and civilian intelligence agencies, to include the 519th MI Battalion (519 MI BN) in late 2002, conducted interrogations in Afghanistan in support of GWOT. As a result, deployed military interrogation units and intelligence agencies in Afghanistan developed certain practices. Later, some of these same techniques surfaced as interrogation techniques in Iraq. Prior to these deployments, US Army interrogators used the doctrine found in FM 34-52. The 1992 FM was what military interrogators at Abu Ghraib were trained on, and it contained the techniques and the restrictions they had been taught. (Reference Annex M, Appendix 3; FM 34-52, Interrogation Operations, [1987 and 1992 versions])

(2) (S//NF)

SECRET//NOFORN//X1

1170

SECRET//NOFORN//X1

SUBJECT: (U) AR 15-6 Investigation of the Abu Ghraib Detention Facility and
205th MI Brigade

(3) (~~S//NF~~)

SECRET//NOFORN//X1

1171

SECRET//NOFORN//X1

SUBJECT: (U) AR 15-6 Investigation of the Abu Ghraib Detention Facility and
205th MI Brigade

(4) (S//NF)

(5) (U) On 16 April 2003, SECDEF approved approaches for use on the Guantanamo "unlawful" combatants, as defined by the President's Military Order of 13 November 2001 and reiterated in the 7 February 2002 memorandum to DoD. Once this document was signed, it became policy at JTF-GTMO, and later became the bedrock on which the CJTF-7 policies were based. The first 18 approaches listed in the 16 April 2003 memo from the SECDEF all appear in the current, 1992, FM 34-52, except the Mutt-and-Jeff approach, which was derived from the superseded 1987 FM 34-52. The remaining approaches, similar to the ones identified in the OGC working group's memorandum derived from the CJTF-180 memorandum and the JTF-GTMO request, included:

- Change of Scenery Down
- Dietary Manipulation
- Environmental Manipulation
- Sleep Adjustment
- False Flag
- Isolation

Although approving all approaches for use, the SECDEF required that he be notified prior to implementing the following approaches:

Incentive/Removal of Incentive	Mutt and Jeff
Pride and Ego Down	Isolation

SECRET//NOFORN//X1

1172

SECRET//NOFORN//X1

SUBJECT: (U) AR 15-6 Investigation of the Abu Ghraib Detention Facility and
205th MI Brigade

(Reference Annex J, Appendix 2, Counter-Resistance Techniques)

(6) (U) No regulatory guidance exists for interrogators aside from DoD Directives 2310.1, DoD Program for Enemy Prisoners of War and Other Detainees and 5100.77, DoD Law of War Program. The most current interrogation procedural guidance is in the 1992 FM 34-52. (Reference Annex M, Appendix 1, DoD Directive 2310.1; Annex M, Appendix 1, DoD Directive 5100.77).

(b) (U) Development of Intelligence and Interrogation Policy in Iraq and Abu Ghraib.

(1) (U) In July 2003, the 519 MI BN, veterans of Afghanistan already at the BIAP facility, simultaneously conducted interrogations of the detainees with possible information of intelligence value and began to develop IROE for interrogators to meet the newly-focused mission. No known documentation exists concerning specific approaches and techniques used before September 2003.

(2) (~~S//NF~~)

(3) (U) Meanwhile, at Headquarters, CJTF-7, as the need for actionable intelligence rose, the realization dawned that pre-war planning had not included planning for detainee operations. Believing that FM 34-52 was not sufficiently or doctrinally clear for the situation in Iraq, CJTF-7 staff sought to synchronize detainee operations, which ultimately resulted in a methodology and structure derived from the JTF-GTMO system as presented by MG G. Miller. At the same time, LTG Sanchez directed that an interrogation policy be established that would address "permissible techniques and safeguards for interrogators" for use in Iraq. The CJTF-7

SECRET//NOFORN//X1

SECRET//NOFORN//X1

SUBJECT: (U) AR 15-6 Investigation of the Abu Ghraib Detention Facility and
205th MI Brigade

staff relied heavily on the series of SOPs which MG G. Miller provided to develop not only the structure, but also the interrogation policies for detainee operations (Reference Annex B, Appendix 1, SANCHEZ).

(4) (U) On 10 September 2003, CPT Fitch, assigned to the 205 MI BDE as the Command Judge Advocate, was tasked by COL Marc Warren, the Staff Judge Advocate (SJA) for CJTF-7, to work with MAJ Daniel Kazmier and MAJ Franklin D. Raab from the CJTF-7 Office of the Staff Judge Advocate (OSJA) to produce a set of interrogation rules. The OSJA identified interrogation policies from the SECDEF 16 April 2003 memo for JTF-GTMO operations. OSJA provided CPT Fitch the 16 April 2003 SECDEF memorandum, which he copied almost verbatim onto a document entitled CJTF-7 Interrogation and Counter-Resistance Policy (ICRP). This document was developed without reference to the 519 MI BN's July 2003 and August 2003 memos. CPT Fitch sent the policy memo to the 519 MI BN for coordination, and the 519 MI BN added the use of dogs, stress positions, sleep management, sensory deprivation, and yelling, loud music and light control from its 27 August 2003 memo. The use of all the techniques was to apply to interrogations of detainees, security internees, and EPWs. CPT Fitch finalized the combined memo and sent it back to the CJTF-7 SJA. It also went to the CJ-2, CJ-3, and the Commander, 205 MI BDE, who until that point had apparently not been involved in drafting or approving the policy. (Reference Annex B, Appendix 1, FITCH, KAZMIER; Annex J, Appendix 3, CJTF-7 Interrogation and Counter-Resistance Policy, [1st Draft], Annex J, Appendix 3, CJTF-7 Interrogation and Counter-Resistance Policy, [2nd Draft])

(5) (U) Between 10 and 14 September 2003, the OSJA at CJTF-7 changed the 10 September 2003 memo to reflect the addition of the techniques that were not included in the JTF-GTMO policy; i.e., the use of dogs, stress positions, and yelling, loud music, and light control. Upon the guidance and recommendation of the SJA staff, it was decided that LTG Sanchez would approve the use of those additional methods on a case-by-case basis.

(6) (S//NF)

SECRET//NOFORN//X1

1174

~~SECRET//NOFORN//X1~~

SUBJECT: (U) AR 15-6 Investigation of the Abu Ghraib Detention Facility and
205th MI Brigade

(7) ~~(S//NF)~~

(8) ~~(S//NF)~~

(9) ~~(S//NF)~~

(10) (U) The 12 October 2003 policy significantly changed the tone and substance of the previous policy. It removed any approach not listed in the 1987 FM 34-52. While acknowledging the applicability of the Geneva Conventions and the duty to treat all detainees humanely, it also cited Articles 5 and 78 noting specifically that those "detainees engaged in activities hostile to security of coalition forces had forfeited their Geneva Convention rights of communication." It also included provisions found in the superseded 1987 FM 34-52 that authorized interrogators to control all aspects of the interrogation, "to include lighting, and heating, as well as food, clothing and shelter given to detainees." This phrase was specifically left out of the 1992 version (See section 3a(2), above). The 12 October 2003 policy also deleted references to EPWs and specified the policy was for use on civilian security internees.

(11) ~~(S//NF)~~

~~SECRET//NOFORN//X1~~

1175

SECRET//NOFORN//X1

SUBJECT: (U) AR 15-6 Investigation of the Abu Ghraib Detention Facility and
205th MI Brigade

(12) (S//NF)

(13) (S//NF)

SECRET//NOFORN//X1

1176

SECRET//NOFORN//X1

SUBJECT: (U) AR 15-6 Investigation of the Abu Ghraib Detention Facility and
205th MI Brigade

(14) (S//NF)

(15) (U) On 16 October 2003, the JIDC Interrogation Operations Officer, CPT Carolyn A. Wood, produced an "Interrogation Rules of Engagement" chart as an aid for interrogators, graphically portraying the 12 October 2003 policy. It listed the approved approaches, and identified the approaches which had been removed as authorized interrogation approaches, which nonetheless could be used with LTG Sanchez's approval. The chart was confusing, however. It was not completely accurate and could be subject to various interpretations. For example, the approved approaches list left off two techniques which previously had been included in the list (the Pride and Ego Down approach and the Mutt and Jeff approach). The right side of the chart listed approaches that required LTG Sanchez's prior approval. What was particularly confusing was that nowhere on the chart did it mention a number of techniques that were in use at the time: removal of clothing, forced grooming, hooding, and yelling, loud music and light control. Given the detail otherwise noted on the aid, the failure to list some techniques left a question of whether they were authorized for use without approval. (Reference Annex J, Appendix 4, CJTF-7 IROE training card)

(16) (U) By mid-October, interrogation policy in Iraq had changed three times in less than 30 days. Various versions of each draft and policy were circulated among Abu Ghraib, 205 MI BDE, CJTF-7 C2, and CJTF-7 SJA. Anecdotal evidence suggests that personnel were confused about the approved policy from as early as 14 September 2003. The SJA believed that the 14 September 2003 policy was not to be implemented until CENTCOM approved it. Meanwhile, interrogators in Abu Ghraib began operating under it immediately. It was not always clear to JIDC officers what approaches required LTG Sanchez's approval, nor was the level of

SECRET//NOFORN//X1

SECRET//NOFORN//X1

SUBJECT: (U) AR 15-6 Investigation of the Abu Ghraib Detention Facility and
205th MI Brigade

approval consistent with requirements in other commands. The JIDC October 2003 SOP, likewise created by CPT Wood, was remarkably similar to the Bagram (Afghanistan) Collection Point SOP. Prior to deployment to Iraq, CPT Wood's unit (A/519 MI BN) allegedly conducted the abusive interrogation practices in Bagram resulting in a Criminal Investigation Command (CID) homicide investigation. The October 2003 JIDC SOP addressed requirements for monitoring interrogations, developing detailed interrogation plans, delegating interrogation plan approval authority to the Interrogation Officer in Charge (OIC), and report writing. It failed to mention details concerning ICRP, approval requirements or procedures. Interrogators, with their section leaders' knowledge, routinely utilized approaches/techniques without obtaining the required authority, indicating confusion at a minimum of two levels of supervision. (Reference Annex J, Appendix 4, JIDC Interrogation SOP; Annex J, Appendix 4, CJTF-180 Bagram Collection Point SOP)

(17) (U) Concepts for the non-doctrinal, non-field manual approaches and practices clearly came from documents and personnel in Afghanistan and Guantanamo. The techniques employed in JTF-GTMO included the use of stress positions, isolation for up to thirty days, removal of clothing, and the use of detainees' phobias (such as the use of dogs) as the 2 December 2002 Counter-Resistance memo, and subsequent statements demonstrate. As the CID investigation mentioned above shows, from December 2002, interrogators in Afghanistan were removing clothing, isolating people for long periods of time, using stress positions, exploiting fear of dogs and implementing sleep and light deprivation. Interrogators in Iraq, already familiar with the practice of some of these new ideas, implemented them even prior to any policy guidance from CJTF-7. These practices were accepted as SOP by newly-arrived interrogators. Some of the CJTF-7 ICRPs neither effectively addressed these practices, nor curtailed their use. (Annex J, Appendix 2, Tab A, Counter-Resistance Techniques; Annex J, Appendix 2, Interrogation Techniques; Annex E, Appendix 4, CID Report)

(18) (~~S//REL TO USA and MCFI~~)

(6) (U) Other Regulatory Procedural Guidance

(a) (U) On 13 November 2001, the President issued a military order entitled the Detention, Treatment and Trial of Certain Non-Citizens in the War Against Terrorism. The

SECRET//NOFORN//X1

SECRET//NOFORN//X1

SUBJECT: (U) AR 15-6 Investigation of the Abu Ghraib Detention Facility and
205th MI Brigade

order authorized US military forces to detain non-US citizens suspected of terrorism, and try them for violations of the law of war and other applicable laws. The order also authorized the SECDEF to detain individuals under such conditions he may prescribe and to issue related orders and regulations as necessary. (Reference Annex J, Appendix 1, Presidential Military Order)

(b) ~~(S//NF)~~

(c) (U) The MP personnel and the MI personnel operated under different and often incompatible rules for treatment of detainees. The MPs referenced DoD-wide regulatory and procedural guidance that clashed with the theater interrogation and counter-resistance policies that the MI interrogators followed. Further, it appears that neither group knew or understood the limits imposed by the other's regulatory or procedural guidance concerning the treatment of detainees, resulting in predictable tension and confusion.

(d) (U) For instance, a MI order to strip a detainee as an interrogation process conflicted with the AR 190-8 directive to treat detainees with respect for their person and honor (Reference Annex M, Appendix 2, AR 190-8, paragraph 5-1a(2)); or to protect detainees against violence, insults, public curiosity, or any form of indecent assault (Reference Annex M, Appendix 2, AR 190-8, paragraph 5-1a(3)); and FM 3-19.40 (Reference Annex M, Appendix 3) (which specifically directs that internees will retain their clothing). A MI order to place a detainee in isolation violated the AR 190-8 directive to not imprison a detainee in a place without daylight (Reference Annex M, Appendix 2, AR 190-8, paragraph 6-11a(5)); to not confine for more than 30 consecutive days, (Reference Annex M, Appendix 2, AR 190-8, paragraph 6-12d(1)); and FM 3-19.40 which specifically directs that the facility commander must authorize any form of punishment. Finally, when interrogators ordered the use of dogs as an interrogation technique, the order violated the policy and intent of AR 190-12. (Reference Annex M, Appendix 2)

4. (U) Summary of Events at Abu Ghraib.

SECRET//NOFORN//X1

SECRET//NOFORN//X1

SUBJECT: (U) AR 15-6 Investigation of the Abu Ghraib Detention Facility and 205th MI Brigade

a. (U) Military Intelligence Organization and Resources.

(1) (U) Task Organization.

(a) (U) The 205 MI BDE was organizationally, and geographically, the size of two MI Brigades. It was composed of four Active and three Reserve Battalions. The 205 MI BDE possessed no organic interrogation elements or personnel. All HUMINT assets (units and personnel) assigned to the 205 MI BDE were from other organizations. Major subordinate elements of the 205 MI BDE included three Tactical Exploitation Battalions (HUMINT and Counterintelligence), one Aerial Exploitation Battalion (Signal Intelligence (SIGINT)) and Imagery Intelligence (IMINT), an Operations Battalion (ANALYSIS), a Linguist Battalion (HUMINT Support) and a Corps Support Battalion (HUMINT). Elements of the Brigade were located throughout Iraq supporting a wide variety of combat operations. (Reference Annex H, Appendix 6, Tab C, 205 MI BDE Command Brief).

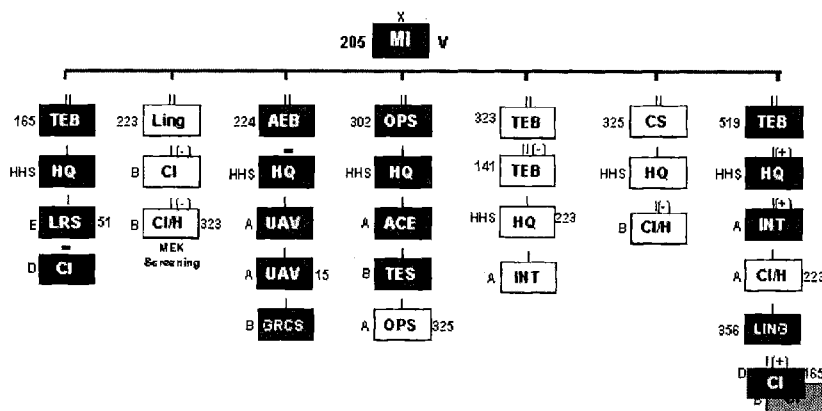

205th MI Brigade Task Organization (August 2003)

(b) (U) The 205 MI BDE Commander, COL Thomas Pappas, had a reputation for being an excellent MI officer with a great background and experience before being selected for command. He took command of the 205 MI BDE on 1 July 2003 while the unit was already deployed in Iraq. His performance as Brigade Commander prior to the Abu Ghraib incidents was "outstanding" according to his rater, MG Wojdakowski, DCG, V Corps/CJTF-7 (Reference Annex B, Appendix 1, WOJDAKOWSKI). LTG Sanchez also believed COL Pappas was an

SECRET//NOFORN//X1

SECRET//NOFORN//X1

SUBJECT: (U) AR 15-6 Investigation of the Abu Ghraib Detention Facility and
205th MI Brigade

excellent and dedicated officer (Reference Annex B, Appendix 1, SANCHEZ). Other key members of COL Pappas's staff included MAJ Potter, Deputy Commander; MAJ M. Williams, Brigade Operations Officer (S-3); and CPT Fitch, Command Judge Advocate.

(2) (U) Resources.

(a) (U) As hostilities began to shift from a tactical fight to an insurgency, so did intelligence priorities. Iraq quickly became a HUMINT-focused environment in support of SASO with interrogation operations representing the intelligence 'Center of Gravity' (Reference Annex B, Appendix 1, SANCHEZ). Beginning in July 2003, demands placed upon interrogation operations were growing rapidly from both the tactical commanders as well as from the CJTF-7. The 205 MI BDE had the missions of providing Tactical HUMINT Teams (THT - small elements consisting of an interrogator, a linguist, and several combat arms Soldiers attached to maneuver elements to conduct tactical interrogations at "the point of the spear") to forward-deployed combat forces as well as operating a Joint Interrogation and Debriefing Center (JIDC).

(b) (U) As previously mentioned, the 205 MI BDE had no organic interrogation capability. Those assets were eliminated from the active force structure during the down-sizing of the Army in the 1990's. The interrogation assets available to COL Pappas when he first took Command were A/519 MI BN and interrogation sections from the 325th MI Battalion (325 MI BN), US Army Reserve (USAR), and 323rd MI Battalion (323 MI BN), USAR. Because both of the USAR units were significantly under strength before being deployed to Iraq, they received many Soldiers from other USAR units country-wide to fill up their ranks. This process is known as "cross-leveling." Although it has the benefit of filling the ranks, it has the disadvantage of inserting Soldiers into units shortly before deployment who had never trained with those units. The Soldiers did not know the unit. The unit and the unit leadership did not know the Soldiers. The Army has always stressed "you train as you fight." As COL Pappas began to focus his efforts on interrogation operations, all he had were disparate elements of units and individuals, including civilians, that had never trained together, but now were going to have to fight together.

(c) (U) Interestingly, and as a matter of comparison, Iraqi Survey Group (ISG) interrogation operations of high-level detainees at BIAP suffered no such shortages of interrogators. Roughly the same level of personnel supported the ISG interrogation operations at BIAP, even though the ISG facility had an order of magnitude less of detainees of intelligence interest to exploit than did the 205 MI BDE (100 at BIAP vs. over a 1000 at Abu Ghraib). Unfortunately, these much needed resources were unavailable for support to critical CJTF-7 mission needs (Reference Annex B, Appendix 1, SANCHEZ).

(d) (U) The number of interrogators initially assigned to the 205 MI BDE was sufficient for a small detainee population of only several hundred. In late July 2003, only 14 interrogation

SECRET//NOFORN//X1

SECRET//NOFORN//X1

SUBJECT: (U) AR 15-6 Investigation of the Abu Ghraib Detention Facility and
205th MI Brigade

personnel were present in the 205 MI BDE to support interrogation operations at Abu Ghraib. All of these personnel were from one unit – A/519 MI BN. By December 2003, Abu Ghraib (the JIDC) had approximately 160 205 MI BDE personnel with 45 interrogators and 18 linguists/translators assigned to conduct interrogation operations. These personnel were from six different MI battalions and groups – the 519 MI BN, the 323 MI BN (USAR), the 325 MI BN (USAR), the 470th MI Group (470 MI GP), the 66th MI Group (66 MI GP), the 500th MI Group (500 MI GP). Additional resources in the form of interrogators from one MTT consisting of six analysts and interrogators, and at just about the same time, three "Tiger Teams" consisting of six personnel from JTF-GTMO, came to Abu Ghraib to assist in improving interrogation operations (See paragraph 4.j.(2)). Still short of resources, the Army hired contract interrogators from CACI International, and contract linguists from Titan Corporation in an attempt to address shortfalls (See paragraph 4.g.). Some units, such as the A/519 MI BN, had personnel who had been deployed to combat operations in theater in excess of 400 days so they also faced a rotation of selected personnel home with the resulting personnel turmoil.

b. (U) Establishment of the Prison at Abu Ghraib.

(1) (U) The Coalition Provisional Authority (CPA) made the initial decision to use Abu Ghraib Prison as a criminal detention facility in May 2003 (Reference Annex B, Appendix 1, SANCHEZ). Abu Ghraib began receiving criminal prisoners in June 2003. There were no MI Holds or security detainees in the beginning. All such categories of detainees were sent to Camp Cropper (located at BIAP) or to the other existing facilities throughout the country such as Camp Bucca (Reference Annex F, Appendix 1, AG Overhead Photo).

(2) (S//NF)

SECRET//NOFORN//X1

1182

SECRET//NOFORN//X1

SUBJECT: (U) AR 15-6 Investigation of the Abu Ghraib Detention Facility and
205th MI Brigade

(3) (U) The Hard Site permanent building facilities at Abu Ghraib were not open for occupancy until 25 August 2003. The opening of the Hard Site was important because it marked the beginning of the serious abuses that occurred. CPT Wood, A/519 MI BN, believed that, based on her experience, the availability of an isolation area to house detainees determined to be of MI value would enhance results. She initiated the request through the 205 MI BDE to CPA for use of part of the Hard Site building for that purpose. Her request received strong support from the 205 MI BDE, specifically from its Operations Officer, MAJ Williams. The 519 MI BN was then granted use of Tier 1A (Reference Annex F, Appendix I, AG Overview Briefing for diagram) to house detainees.

c. (U) Detention Operations and Release Procedures

(1) (S//NF)

(2) (S//NF)

SECRET//NOFORN//X1

1183

SECRET//NOFORN//X1

SUBJECT: (U) AR 15-6 Investigation of the Abu Ghraib Detention Facility and
205th MI Brigade

(3) (S//NF)

(4) (S//NF)

(5) (S//NF)

SECRET//NOFORN//X1

1184

SECRET//NOFORN//X1

SUBJECT: (U) AR 15-6 Investigation of the Abu Ghraib Detention Facility and
205th MI Brigade

SECRET//NOFORN//X1

SECRET//NOFORN//X1

SUBJECT: (U) AR 15-6 Investigation of the Abu Ghraib Detention Facility and
205th MI Brigade

(6) (U) The problems cited above contributed significantly to the overcrowding at Abu Ghraib. Overcrowding was even further exacerbated with the transfer of detainees from Camp Bucca to Abu Ghraib. The physical plant was totally inadequate in size and the construction and renovations that were underway were incomplete. Scarcity of resources – both personnel and equipment – to conduct effective confinement or interrogation operations made the situation worse.

(7) (U) There was general consensus (Reference Annex B, Appendix 1, FAST, CIVILIAN-12, LYONS, WOOD, SOLDIER14, SANCHEZ) that as the pace of operations picked up in late November – early December 2003, it became a common practice for maneuver elements to round up large quantities of Iraqi personnel in the general vicinity of a specified target as a cordon and capture technique. Some operations were conducted at night resulting in some detainees being delivered to collection points only wearing night clothes or under clothes. SGT Jose Garcia, assigned to the Abu Ghraib Detainee Assessment Board, estimated that 85% - 90% of the detainees were of no intelligence value based upon board interviews and debriefings of detainees. The Deputy C2X, CJTF-7, CIVILIAN-12, confirmed these numbers. (Reference Annex B, Appendix 1, GARCIA, CIVILIAN-12). Large quantities of detainees with little or no intelligence value swelled Abu Ghraib's population and led to a variety of overcrowding difficulties. Already scarce interrogator and analyst resources were pulled from interrogation operations to identify and screen increasing numbers of personnel whose capture documentation was incomplete or missing. Complicated and unresponsive release procedures ensured that these detainees stayed at Abu Ghraib – even though most had no value.

(8) (U) To make matters worse, Abu Ghraib increasingly became the target of mortar attacks (Reference Annex F, Appendix 3 shows an image of mortar round strikes at Abu Ghraib prior to February 2004 and the times of mortar strikes from January-April 2004) which placed detainees – innocent and guilty alike – in harms way. Force protection was a major issue at Abu Ghraib. The prison is located in a hostile portion of Iraq, adjacent to several roads and highways, and near population centers. BG Karpinski recognized Abu Ghraib's vulnerabilities and raised these concerns frequently to both MG Wojdakowski and LTG Sanchez (Reference Annex B, Appendix 1, KARPINSKI). LTG Sanchez was equally concerned with both the inherent vulnerability of Abu Ghraib and frustrated with the lack of progress in establishing even rudimentary force protection measures and plans (Reference Annex B, Appendix 1, SANCHEZ). LTG Sanchez directed that measures be taken to improve the force protection situation even to the point of having the 82nd Airborne Division Commander meet with Abu Ghraib officers concerning the issue. But, little progress was made and the mortar attacks continued. In an effort to improve force protection at Abu Ghraib, LTG Sanchez directed COL Pappas assume Tactical Control (TACON) of the Abu Ghraib Forward Operating Base (FOB) (Reference Annex H, Appendix 1, FRAGO 1108) on 19 November 2003. COL Pappas devoted considerable energy to improving security, even to the point of bringing a subordinate battalion commander to Abu

SECRET//NOFORN//X1

SECRET//NOFORN//X1

SUBJECT: (U) AR 15-6 Investigation of the Abu Ghraib Detention Facility and
205th MI Brigade

Ghraib to coordinate force protection plans and operations. In spite of these efforts, the mortar attacks continued and culminated in an attack in April 2004 killing 22 detainees and wounding approximately 80 others, some seriously. This highlights the critical need for adequate force protection for a detainee center.

(9) (U) The Security Internec Review and Appeal Board was established on 15 August 2003. It served as the release authority for security internees and/or those on MI Hold who were deemed to be of no security threat or (further) intelligence value. It consisted of three voting members - the C2, CJTF-7 (MG Fast), the Commander 800 MP BDE (BG Karpinski), and the CJTF-7 SJA (COL Warren), and two non-voting members (a SJA recorder and a MI assistant recorder). When first instituted, it was to meet on an "as required" basis; however, it appeared to be difficult to balance the schedules of three senior officers and the necessary support staff on a recurring, regular basis. Due to poor record keeping, accurate detainee release statistics are not available. We do know that by 2 October 2003, only 220 files had been reviewed by the board (Reference Annex H, Appendix 9, 031002 Oct CJTF7 JA Memo for CG). A preliminary screening board (Appellate Review Panel) at a level of authority below the General Officers on the Security Internec Review and Appeal Board was established to speed up the review of files by the General Officers. In the October – November 2003 timeframe, only approximately 100 detainee files a week were considered for release (Reference Annex B, Appendix 1, SUMMERS). As the detainee population increased, it became necessary to have the meetings on a much more frequent basis – initially twice a week. In the January 2004 timeframe, the board was meeting six times a week (Reference Annex B, Appendix 1, FAST). By February 2004, a standing board was established to deal with the ever increasing backlog. Even with more frequent meetings, the release of detainees from Abu Ghraib did not keep pace with the inflow. BG Karpinski believed that MG Fast was unreasonably denying detainees' release. By 11 January 2004, 57 review boards had been held and 1152 detained personnel had been released out of a total of 2113 considered. From February 2004 on, the release flow increased. (Reference Annex C, Appendix 1, Tab B, Annex 104)

(10) (U) As of late May 2004, over 8500 detainees had been reviewed for release, with 5300 plus being released and 3200 plus being recommended for continued internment. (Reference Annex H, Appendix 9, CJTF-7 C2X email). Even those that were initially deemed of no intelligence value and those that had been drained of intelligence information were not released on a timely basis – not as the result of any specific policy, but simply because the system that supported the release board (screening, interviews, availability of accurate records, and coordination) and the release board itself could not keep up with the flow of detainees into Abu Ghraib. Even with these long release delays (often 6 months and longer), there were concerns between the intelligence and tactical sides of the house. Combat Commanders desired that no security detainee be released for fear that any and all detainees could be threats to coalition forces. On occasion, Division Commanders overturned the recommendations of

SECRET//NOFORN//X1

SECRET//NOFORN//X1

SUBJECT: (U) AR 15-6 Investigation of the Abu Ghraib Detention Facility and
205th MI Brigade

Division Staffs to release some detainees at the point of capture (Reference Annex B, Appendix 1, PHILLABAUM). The G2, 4 ID informed MG Fast that the Division Commander did not concur with the release of any detainees for fear that a bad one may be released along with the good ones. MG Fast described the 4ID's response to efforts to coordinate the release of selected detainees, "...we wouldn't have detained them if we wanted them released." (Reference Annex B, Appendix 1, FAST, CIVILIAN-12). MG Fast responded that the board would ultimately release detainees if there was no evidence provided by capturing units to justify keeping them in custody.

(11) (U) The chart below depicts the rise in detainee 'MI Hold' population (those identified by the "system" to be deemed of intelligence interest) (Reference Annex H, Appendix 5). SOLDIER-14, the officer at Abu Ghraib primarily responsible for managing collection requirements and intelligence reporting, estimated that only 10-15% of the detainees on MI Hold were of actual intelligence interest. (Reference Annex B, Appendix 1, SOLDIER-14)

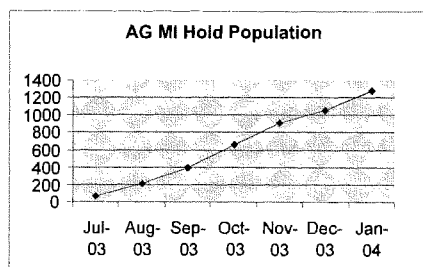

(12) (U) Interrogation operations in Abu Ghraib suffered from the effects of a broken detention operations system. In spite of clear guidance and directives, capturing units failed to perform the proper procedures at the point-of-capture and beyond with respect to handling captured enemy prisoners of war and detainees (screening, tactical interrogation, capture cards, sworn statements, transportation, etc.). Failure of capturing units to follow these procedures contributed to facility overcrowding, an increased drain on scarce interrogator and linguist resources to sort out the valuable detainees from innocents who should have been released soon after capture, and ultimately, to less actionable intelligence.

d. (U) Establishment of MP Presence at Abu Ghraib. The first Army unit to arrive was the 72nd MP Company (72 MP CO), Nevada Army National Guard. When first assigned to Abu Ghraib, the 72 MP CO was a subordinate unit of the 400th MP Battalion (400 MP BN)

SECRET//NOFORN//X1

SECRET//NOFORN//X1

SUBJECT: (U) AR 15-6 Investigation of the Abu Ghraib Detention Facility and
205th MI Brigade

headquartered at BIAP. The 320th MP Battalion (320 MP BN) advance party was the next to arrive at Abu Ghraib on 24 July 2003. The rest of the 320 MP BN Headquarters, commanded by LTC Phillabaum arrived on 28 July 2003. With the 320 MP BN came one of its subordinate units, the 447th MP Company (447 MP CO). The 72 MP CO was then reassigned from the 400 MP BN to the 320 MP BN. The next unit to arrive was the 229th MP Company (229 MP CO) on or about 3 August 2003. On 1 October 2003, SSG Frederick, CPL Graner and other MPs who have allegedly abused detainees, arrived as part of the 372 MP CO. The rest of the 320 MP CO arrived in late October 2003, followed by the 870th MP Company (870 MP CO) and 670 MP Company (670 MP CO) on approximately 14 November 2003.

e. (U) Establishment of MI Presence at Abu Ghraib.

(1) (U) The first MI unit to arrive at Abu Ghraib was a detachment from A/519 MI BN on 25 July 2003. The person in charge of that contingent was 1SGT McBride. Soldiers from the 519 MI BN had been sent there to prepare for OVB. CPT Wood arrived at Abu Ghraib on 4 August 2003 to assume the duties of Interrogation Operations OIC. MAJ Thompson arrived on or about 10 September 2003 along with elements of the 325 MI BN. MAJ Thompson was sent by COL Pappas to set up the JIDC at Abu Ghraib. LTC Jordan arrived at Abu Ghraib on 17 September 2003 to become the Director of the JIDC. MAJ Price and elements of the 323 MI BN arrived at the end of September 2003. MAJ Price had been the OIC of the interrogation operation at Camp Bucca. He became the Operations Officer of the JIDC, working closely with MAJ Thompson and CPT Wood. Most of the personnel from the 323 MI BN element that arrived with MAJ Price were used as the Headquarters element and did not directly participate in interrogations.

(2) (U) Civilian CACI contract interrogators began to arrive in late September 2003. There are a number of shortfalls connected to this issue (See paragraph 4.g., below). It was another complicating factor with respect to command and control. CPT Wood relied on the CACI site manager, CIVILIAN-18, to interview contractors as they arrived and to assign them based on his interviews. She knew little of their individual backgrounds or experience and relied on "higher headquarters" to screen them before arrival. Such screening was not occurring.

(3) (U) During October 2003, in addition to the elements of the already mentioned MI units and the Titan and CACI civilians, elements of the 470 MI GP, 500 MI GP, and 66 MI GP appeared. These units were from Texas, Japan, and Germany, and were part of the US Army Intelligence and Security Command (INSCOM), which tasked those subordinate units to send whatever interrogator and analyst support they had available. MAJ Thompson rotated back to the US on 15 November 2003. CPT Wood left on emergency leave on 4 December 2003 and never returned. MAJ Price, then, was the only commissioned officer remaining in the Operations Section.

SECRET//NOFORN//X1

SECRET//NOFORN//X1

SUBJECT: (U) AR 15-6 Investigation of the Abu Ghraib Detention Facility and
205th MI Brigade

(4) (U) It is important to understand that the MI units at Abu Ghraib were far from complete units. They were small elements from those units. Most of the elements that came to Abu Ghraib came without their normal command structure. The unit Commanders and Senior NCOs did not go to Abu Ghraib but stayed with the bulk of their respective units. The bringing together of so many parts of so many units, as well as civilians with very wide backgrounds and experience levels in a two month time period, was a huge challenge from a command and control perspective.

f. (U) Establishment, Organization, and Operation of the Joint Interrogation Debriefing Center (JIDC)

(1) (U) The idea for the creation of the JIDC came about after a number of briefings and meetings were held among LTG Sanchez, MG Fast, COL Pappas, and COL Steven Boltz, Assistant C2, CJTF-7. These meetings and briefings occurred about mid-August 2003 through early September 2003. They partially coincided with MG G. Miller's arrival from GTMO. He and his team provided an assessment of detainee operations in Iraq from 31 August to 9 September 2003 (See Paragraph 4.j.(1)). MG G. Miller's discussions with the CJTF personnel and the 205 MI BDE personnel influenced the decision to create a JIDC and how it would be organized, but those discussions were already underway before his arrival. The objective for the establishment of the JIDC was to enhance the interrogation process with a view toward producing better, timelier, actionable intelligence (actionable intelligence provides commanders and Soldiers a high level of situational understanding, delivered with speed, accuracy, and timeliness, in order to conduct successful operations).

(2) (U) On 6 September 2003, COL Pappas briefed LTG Sanchez on a plan to improve interrogation operations resulting from a 31 August 2003 meeting (Reference Annex H, Appendix 10). LTG Sanchez approved the concept and directed COL Pappas to accelerate all aspects of the plan. This decision established the JIDC and modified previous interrogation operations at Abu Ghraib. COL Pappas decided when standing up the JIDC not to make it a battalion operation (Reference Annex B, Appendix 1, WILLIAMS), therefore deciding not to place one of his battalion commanders in charge of the JIDC but instead rely upon staff personnel to manage the entire operation. The current operation would be transitioned to a JIDC by personnel already assigned at Abu Ghraib with additional manning provided by the consolidation of security detainee interrogation operations from other locations (e.g., Camp Cropper). LTC Jordan would become the Director of the JIDC on 17 September 2003. Other key JIDC personnel included CPT Wood (OIC ICE), MAJ Thompson (JIDC Operations Officer), MAJ Price (JIDC Operations Officer), SOLDIER-14 and SOLDIER-23 (Interrogation Technicians). CJTF-7 decided to use the JTF-GTMO Tiger Team concept which uses an interrogator, an intelligence analyst, and an interpreter on each team. A re-organization of the

SECRET//NOFORN//X1

SECRET//NOFORN//X1

SUBJECT: (U) AR 15-6 Investigation of the Abu Ghraib Detention Facility and
205th MI Brigade

JIDC took place in the late September to October 2003 timeframe which divided Tiger Teams into functional categories.

(3) (U) The reorganization introduced another layer of complexity into an already stressed Abu Ghraib interrogation operations environment. The Tiger Team worked well at GTMO. JTF-GTMO's target population and mission, however, were different from what was faced in Iraq. The Tiger Team method was designed to develop strategic level information from the GTMO detainees who were primarily captured in Afghanistan. By the time they reached GTMO any tactical value they may have had was gone. The same is true for Abu Ghraib relative to Iraq. The best place to collect tactical intelligence from interrogations is at the tactical level. Tactical intelligence is the most perishable, and the faster you harvest it the more useful it will be to help that tactical unit. JIDC personnel at Abu Ghraib believed the thirst for intelligence reporting to feed the national level systems was driving the train. There was then a focus to fill that perceived void and feed that system. LTG Sanchez did not believe significant pressure was coming from outside of CJTF-7, but does confirm that there was great pressure placed upon the intelligence system to produce actionable intelligence (Reference Annex B, Appendix 1, SANCHEZ). The Tiger Team concept should have only been used at Abu Ghraib for any high value targets identified. Those targets should receive careful planning and preparation, and be interrogated by the most experienced interrogators, analysts, and interpreters. Using a Tiger Team at Corps (the JIDC) for developing tactical intelligence did not work.

(4) (U) The JIDC is a non-doctrinal organization. Initially, there was no joint manning document for the JIDC (though one was developed by the 205 MI BDE over time and was submitted to CJTF-7). There was no approved structure for the JIDC. The manning document was being created as the JIDC was already operating (Reference Annex B, Appendix 1, WILLIAMS, Maurice). Because there is no JIDC doctrine (or training), procedures were ad hoc in nature – adapted from FM 34-52 where possible, though most processes and procedures were developed on the fly based upon the needs of the situation. The organization of the JIDC changed often (Reference Annex H, Appendix 6, Tab B) and contributed to the general state of turmoil at Abu Ghraib. Interrogators were not familiar with the new working arrangements (e.g., working with analysts) and were only slightly trained on the conduct of interrogations using translators. Note that most interrogators are only trained in conducting tactical interrogations in a conventional war environment (See paragraph 3.b.(3)). In spite of this turmoil, lack of training and doctrine, and shortages, the JIDC did mature over time and improved intelligence production derived from interrogations at Abu Ghraib.

(5) (U) Early in the formation of the JIDC, COL Pappas requested COL Boltz provide him with a Lieutenant Colonel to run the new organization because the responsibilities would require someone of that rank and commensurate experience. LTC Jordan had just arrived in Iraq four days earlier. He was originally sent to be COL Boltz's Deputy C2 but then a decision was made

SECRET//NOFORN//X1

SECRET//NOFORN//X1

SUBJECT: (U) AR 15-6 Investigation of the Abu Ghraib Detention Facility and
205th MI Brigade

to upgrade the C2 position from a COL to a MG. MG Fast was sent to CJTF-7 to be the C2, COL Boltz became the Deputy C2 and LTC Jordan became excess. Since LTC Jordan was available, COL Boltz assigned him to Abu Ghraib to run the JIDC. COL Boltz expected LTC Jordan to report to COL Pappas because COL Pappas had command responsibility for the JIDC. LTC Jordan was assigned to the JIDC verbally. He states that he never received orders (Reference Annex B, Appendix 1, JORDAN, BOLTZ).

(6) (U) There is a significant difference between what LTC Jordan claims he was told when he was sent to Abu Ghraib and what COL Pappas and COL Boltz say he was told. LTC Jordan says he was sent to be a "liaison" officer between CJTF-7 and the JIDC. COL Pappas and COL Boltz say he was sent there to be in charge of it. Reference to titles is useless as a way to sort through this because there was no actual manning document for reference; people made up their own titles as things went along. Some people thought COL Pappas was the Director; some thought LTC Jordan was the Director. A major shortcoming on the part of COL Pappas and LTC Jordan was the failure to do a formal Officer Evaluation Report (OER) support form, Department of Army (DA) Form 67-8-1, to clearly delineate LTC Jordan's roles and responsibilities. It is clear that both had their own ideas as to roles and responsibilities, and an initial goal-setting session formalized via the support form would have forced both parties to deal in specifics. Such sessions are frequently done after the fact; especially in stress-filled combat situations. The less organized the situation, however, the more such a process is needed in order to sort out the boundaries and lanes in the road. Abu Ghraib was certainly a place and a situation that required both clear boundaries and clear lanes in the road. LTC Jordan did provide a support form that he said he did some weeks after his assignment to Abu Ghraib and which he sent to COL Boltz. COL Boltz claims he never received it. LTC Jordan never received a signed copy back from COL Boltz and never followed up to get one. Even if LTC Jordan had sent the support form a few weeks later as he states, it was by then too late. The confusion/damage had been done. The early stages of the Abu Ghraib operation were the most critical to the disastrous end results (Reference Annex B, Appendix 1 BOLTZ, PAPPAS, JORDAN).

(7) (U) The preponderance of evidence supports the COLs Pappas/Boltz position that LTC Jordan was sent to run the JIDC. (Reference Annex B, Appendix 1, PAPPAS and BOLTZ). MAJ M. Williams, Operations Officer of the 205 MI BDE, and MAJ L. Potter, Deputy Commander of the 205 MI BDE, were adamant that LTC Jordan was sent for that reason. LTC Phillabaum believed LTC Jordan was in charge once he arrived at Abu Ghraib and started dealing directly with him. In all but one important aspect, interrogation operations, LTC Jordan began to act as if he were in charge.

(8) (U) As is now evident, LTC Jordan was a poor choice to run the JIDC. He was a Civil Affairs officer. He was an MI officer early in his career, but transferred to Civil Affairs in 1993. The MI experience he did have had not been in interrogation operations. LTC Jordan left the

SECRET//NOFORN//X1

SECRET//NOFORN//X1

SUBJECT: (U) AR 15-6 Investigation of the Abu Ghraib Detention Facility and
205th MI Brigade

actual management, organization, and leadership of the core of his responsibilities to MAJ Thompson and CPT Wood. The reality of the situation was that MAJ Thompson and CPT Wood were overwhelmed by the huge demands of trying to organize, staff, equip, and train the JIDC while at the same time answering incessant requests for information from both the 205 MI BDE as well as from CJTF-7. What the JIDC needed in the beginning, more than ever, was a trained, experienced MI LTC. COL Pappas was correct in his assessment of what was required. In the critical early stages of the JIDC, as it was being formed, Abu Ghraib needed a LTC to take total control. The need was for a leader to get the JIDC organized, to set standards, enforce discipline, create checks and balances, establish quality controls, communicate a zero tolerance for abuse of detainees, and enforce that policy by quickly and efficiently punishing offenders so that the rest of the organization clearly understood the message. Well-disciplined units that have active, involved leaders both at the NCO and Officer level are less likely to commit abuses or other such infractions. If such instances do occur, they are seldom repeated because those leaders act aggressively to deal with the violators and reemphasize the standards (Reference Annex B, Appendix 1, BOLTZ, PAPPAS, JORDAN).

(9) (U) LTC Jordan gravitated to what he knew, and what he was comfortable with, rather than filling the void noted above. He was actually a very hard working officer who dedicated himself to improving life for all of the Soldiers at Abu Ghraib. He is physically brave, volunteered for Iraq, and was wounded in action at Abu Ghraib during the mortar attack on 20 September 2003. He addressed shortcomings in the mess situation, lack of exercise equipment, protective gear, living conditions, and communications. He also enforced stricter adherence to the uniform policies and the wearing of protective gear by Soldiers and contractors. Many of the Soldiers that we spoke to, both MPs and MI, considered LTC Jordan the "go to guy" to get the types of things just enumerated done. BG Karpinski even remarked once to LTC Jordan during one of her visits "Do you ever sleep?" (Reference Annex B, Appendix 2, KARPINSKI). Unfortunately, all of the issues he was addressing should have been left to the staffs of the 205 MI BDE and the 320 MP BN. He was not the FOB Commander. LTC Phillabaum was the FOB Commander until the 19 November 2003 FRAGO. (Annex B, Appendix 1, JORDAN).

(10) (U) LTC Jordan became fascinated with the "Other Government Agencies," a term used mostly to mean Central Intelligence Agency (CIA), who were operating at Abu Ghraib. The OGA "Ghost Detainee" issue (housing of detainees not formally accounted for) was well known within both the MI and MP communities and created a mystique about what "they" were doing (See paragraph 4.h.). LTC Jordan allowed OGA to do interrogations without the presence of Army personnel (Reference Annex B, Appendix 1, WOOD, THOMPSON, and PRICE). Prior to that time, JIDC policy was that an Army interrogator had to accompany OGA if they were interrogating one of the detainees MI was also interrogating. As noted above, LTC Jordan was little involved in the interrogation operations, but in this aspect he did become involved and it did not help the situation. The lack of OGA adherence to the practices and procedures

SECRET//NOFORN//X1

SECRET//NOFORN//X1

SUBJECT: (U) AR 15-6 Investigation of the Abu Ghraib Detention Facility and
205th MI Brigade

established for accounting for detainees eroded the necessity in the minds of Soldiers and civilians for them to follow Army rules.

(11) (U) LTC Jordan and ten other Soldiers were wounded in the mortar attack that occurred on 20 September 2003. Two Soldiers died in that attack. LTC Jordan was extremely traumatized by that attack, especially by the two deaths and the agony suffered by one of those Soldiers before his death. He was still very emotional about that attack when interviewed for this investigation on 27 May 2004. He said he thinks about the attack and the deaths daily. That attack also had an impact on a number of other Soldiers at Abu Ghraib as did the very frequent mortar attacks that occurred at Abu Ghraib during this entire period. The Soldiers' and civilians' morale at Abu Ghraib suffered as the attacks continued. Additionally, there was a general feeling by both MI and MP personnel that Abu Ghraib was the forgotten outpost receiving little support from the Army. (Reference Annex F, Appendix 3, Mortar Attacks). The frequency of these attacks and the perceived lack of aggressive action to prevent them were contributing factors to the overall poor morale that existed at Abu Ghraib.

(12) (U) COL Pappas perceived intense pressure for intelligence from interrogations. This began soon after he took Command in July 2003. In fact, as the time progressed from July 2003 through January 2004, interrogation operations at Abu Ghraib became the central focus of his efforts despite the fact that he was in command of the entire MI Brigade. That pressure for better results was passed from COL Pappas to the rest of the JIDC leadership (including MAJ Thompson, MAJ Price, CPT Wood, SOLDIER-23, and SOLDIER-14) and from them to the interrogators and analysts operating at Abu Ghraib. Pressure consisted in deviation from doctrinal reporting standards (pressure to report rapidly any and all information in non-standard formats such as Interrogator Notes in lieu of standard intelligence reports), directed guidance and prioritization from "higher," outside of doctrinal or standard operating procedures, to pursue specific lines of questioning with specific detainees, and high priority 'VFR Direct' taskings to the lowest levels in the JIDC. This pressure should have been expected in such a critical situation, but was not managed by the leadership and was a contributing factor to the environment that resulted in abuses. (Reference Annex B, Appendix 1, PAPPAS, BOLTZ, LYONS, WOOD, JORDAN, WILLIAMS, Maurice, POTTER, THOMAS, PRICE; and Annex B, Appendix 2, FAST, GEOFFREY MILLER, THOMAS MILLER).

(13) (U) The most critical period of time for Abu Ghraib was when COL Pappas committed a critical error in judgment by failing to remove LTC Jordan as soon as his shortcomings were noted, on approximately 10 October 2003. Very shortly after LTC Jordan's arrival at Abu Ghraib, on or about 17 September 2003, the 205 MI BDE Staff began to note LTC Jordan's involvement in staff issues and his lack of involvement in interrogation operations. The situation as described above would have been a daunting challenge for the most experienced, well trained, MI Officer. COL Pappas knew LTC Jordan was not who was needed to fulfill the JIDC

SECRET//NOFORN//X1

SECRET//NOFORN//X1SUBJECT: (U) AR 15-6 Investigation of the Abu Ghraib Detention Facility and
205th MI Brigade

functions early on, but nevertheless chose to see if LTC Jordan could work out over time. COL Pappas made more frequent visits during this time period both because he was receiving increasing pressure for results but also because he could not rely on LTC Jordan to run the entire operation.

(14) (U) As pointed out clearly in the MG Taguba report, MP units and individuals at Abu Ghraib lacked sufficient training on operating a detainment/interrogation facility. MI units and individuals also lacked sufficient, appropriate, training to cope with the situation encountered at Abu Ghraib (See Paragraph 3.b.(4)). An insurgency is HUMINT intensive. The majority of that HUMINT comes from interrogations and debriefings. Yet at the JIDC, which was set up to be the focal point for interrogation operations, there was only one officer, CPT Wood, with significant interrogation operations experience. There were four MI Warrant Officers but all were used for staff functions rather than directly supervising and observing interrogations. There was a shortage of trained NCOs at the E-7/E-6 level. Each Section Leader had four or five Tiger Teams, too many to closely observe, critique, counsel, consult, and supervise. One Section Leader was an E-5. Several of the interrogators were civilians and about half of those civilians lacked sufficient background and training. Those civilians were allowed to interrogate because there were no more military assets to fill the slots. (Reference Annex B, Appendix 1, PAPPAS). Such a mixture together with constant demands for reports and documentation overwhelmed the Section Leaders. The analysts assigned to Tiger Teams were not all trained 96Bs, but were a mixture of all available intelligence Military Occupational Specialties (MOS). Many of those assigned as analysts had never been trained nor had they ever served as analysts.

(15) (U) Guard and interrogation personnel at Abu Ghraib were not adequately trained or experienced and were certainly not well versed in the cultural understanding of the detainees. MI personnel were totally ignorant of MP lanes in the road or rules of engagement. A common observation was that MI knew what MI could do and what MI couldn't do; but MI did not know what the MPs could or could not do in their activities. The same was true of MP ignorance of MI operational procedures. Having two distinct command channels (MI and MP – see Command and Control) in the same facility with little understanding of each other's doctrinal and regulatory responsibilities caused uncertainty and confusion. There was a perception among both MI and MP personnel that the other group was not doing its fair share in mutually supportive tasks of running the physical plant. CIVILIAN-12 (Assistant CJTF-7 C2X) observed that confusion seemed to be the order of the day at Abu Ghraib. There was hostility between MI and MP personnel over roles and responsibilities (Reference Annex B, Appendix 1, CIVILIAN-12). There was a distinct lack of experience in both camps. Except for some of the Reserve Component MPs who had civilian law enforcement experience, most of the MPs were never trained in prison operations. Because of the shortage of MPs, some MI personnel had to assume detainee escort duties, for which they received only the most rudimentary training.

SECRET//NOFORN//X1

SECRET//NOFORN//X1

SUBJECT: (U) AR 15-6 Investigation of the Abu Ghraib Detention Facility and
205th MI Brigade

(16) (U) Abu Ghraib rapidly evolved from a tactical interrogation operation in July 2003 to a JIDC beginning in September 2003. Doctrine, SOPs, and other tactics, techniques and procedures (TTP) for a JIDC were initially non-existent. The personnel manning the JIDC came from numerous units, backgrounds, and experiences. Equipment such as computers, software, IT infrastructure (networks, data storage), and connectivity to relevant intelligence data bases was very limited. Even file cabinets were in short supply which resulted in lost documents. One JIDC Soldier stated, "I can believe them (files for requests for exceptions to policy) getting lost because we often lost complete files. Our filing system was not the best. We did not have serviceable file cabinets and teams were given approval to place files in cardboard boxes." (Reference Annex B, Appendix 1, ADAMS) Initially there was only one computer available for every four interrogators. Ad hoc data bases were built, employed, and modified as requirements dictated. Data connectivity between interrogators and analysts was established using "thumb drives." Forms, intelligence products, and database formats came and went based upon their immediate utility – many times dictated by the changing structure of the JIDC itself as directed by leadership. Critical records regarding each detainee were located in several electronic and hardcopy locations – the operations officers maintained some files, others were maintained by section leaders, others by collection management personnel, and others by Detainee Release Board (DRB) personnel. Some interrogation related information was recorded on a whiteboard which was periodically erased. No centralized management system existed to manage interrogation operations. One result was that detainee records critical to the evaluation of prisoners for a variety of reasons (for intelligence value assessment, release, medical evaluation, etc.) were difficult to find or construct. MP records at Abu Ghraib were equally primitive. These documentation shortfalls not only hindered effective interrogation operations and information sharing, but also hindered the ability of the Security Internee Review and Appeal Board (which relied upon records reviews to make decisions to release or retain detainees). As addressed earlier, many detainees arrived at Abu Ghraib with little or no documentation from capturing units. Follow-on records maintained by the MP and MI personnel at Abu Ghraib would be sparse if the detainee had not been thoroughly interrogated. DRBs were reluctant to release a detainee if they knew little about him. MG Fast noted that one detainee file that was reviewed by the release board was completely empty. Even detainee medical records that should have been created and stored (Reference Annex H, Appendix 8) were not maintained appropriately. Medical doctors on site at Abu Ghraib claim that excellent medical records were maintained on detainees (Reference Annex B, Appendix 1, ACKERSON). Only a few detainee medical records could be found, indicating that they are not being maintained IAW AR 40-66 (Medical Records Administration and Healthcare Documentation).

g. (U) Contract Interrogators and Linguists

(1) (U) Contracting-related issues contributed to the problems at Abu Ghraib prison. Several of the alleged perpetrators of the abuse of detainees were employees of government

SECRET//NOFORN//X1

SECRET//NOFORN//X1

SUBJECT: (U) AR 15-6 Investigation of the Abu Ghraib Detention Facility and
205th MI Brigade

contractors. Two contractual arrangements were involved: one with CACI, for interrogators and several other intelligence - related occupational categories; and one with BTG, for linguists. Since 28 November 2001, BTG has been part of Titan Corporation. The contract is still in the name of BTG. Most people have referred to it as the Titan Contract. A brief description of these two contractual arrangements follows:

(a) (U) Linguist contract- Titan, Inc. - Contract DASC01-99-D-0001.

[1] (U) The need to supplement the Army's capacity for linguists was first raised to the Vice Chief of Staff of the Army in a 1997 "Foreign Language Lay down." It was proposed to establish a contract with the private sector to provide linguists, as needed, for contingencies and current intelligence operations.

[2] (U) As a result of this perceived need, INSCOM awarded Contract DASC01-99-D-0001 to Titan, in March 1999. The contract called for Titan initially to develop a plan to provide and manage linguists throughout the world, and later, implement the plan as required. The contract called for three levels of linguists- some were required to obtain security clearances and some were not. The linguist candidates were subject to some level of background investigations, based on individual requirements for security clearances. Since the award of the contract, hundreds of linguists have been provided, with generally positive results. It is noted that the contract calls for translation services only, and makes no mention of contractor employees actually conducting interrogations. Since the statement of work is limited to translation services, the linguists apparently were not required to review and sign the IROE at Abu Ghraib. A recent review of the contract indicated that the current contract ceiling is approximately \$650 Million. Other agencies can order linguist services under this contract. For the most part, the ordering activity also provides the funds for these delivery orders. The contract contains a clause that allows the Contracting Officer to direct the contractor to remove linguists from the theater in which they are performing. This clause has been invoked on occasion for misconduct.

(b) Interrogator contract-CACI, Inc.

[1] (U) The second contractual arrangement is a series of Delivery Orders awarded to CACI, in August 2003, which call for the provision of numerous intelligence-related services such as "Interrogator Support," "Screening Cell Support," "Open Source Intelligence," "Special Security Office," "HUMINT Augmentee Contractors" (which includes "Interrogation Support," "Junior Interrogators," "Senior and Junior Counter-Intelligence Agents," and "Tactical/Strategic Interrogators").

SECRET//NOFORN//X1

SECRET//NOFORN//X1

SUBJECT: (U) AR 15-6 Investigation of the Abu Ghraib Detention Facility and
205th MI Brigade

[2] (U) These Delivery Orders were awarded under a Blanket Purchase Agreement (BPA) (NBCHA01-0005) with the National Business Center (NBC), a fee for service activity of the Interior Department. The BPA between CACI and NBC set out the ground rules for ordering from the General Services Administration (GSA) pursuant to GSA Schedule Contract GS-35F-5872H, which is for various Information Technology (IT) Professional Services. Approximately eleven Delivery Orders were related to services in Iraq. While CJTF-7 is the requiring and funding activity for the Delivery Orders in question, it is not clear who, if anyone, in Army contracting or legal channels approved the use of the BPA, or why it was used.

[3] (U) There is another problem with the CACI contract. A CACI employee, Thomas Howard, participated with the COR, LTC Brady, in writing the Statement of Work (SOW) prior to the award of the contract (Reference Annex B, Appendix 1, BOLTZ). This situation may violate the provisions of Federal Acquisition Regulation (FAR) 9. 505-2 (b) (1).

[4] (U) On 13 May 2004, the Deputy General Counsel (Acquisition) of the Army issued an opinion that all Delivery Orders for Interrogator Services should be cancelled immediately as they were beyond the scope of the GSA Schedule contract.

(2) (U) Although intelligence activities and related services, which encompass interrogation services, should be performed by military or government civilian personnel wherever feasible, it is recognized that contracts for such services may be required in urgent or emergency situations. The general policy of not contracting for intelligence functions and services was designed in part to avoid many of the problems that eventually developed at Abu Ghraib, i.e., lack of oversight to insure that intelligence operations continued to fall within the law and the authorized chain of command, as well as the government's ability to oversee contract operations.

(3) (U) Performing the interrogation function in-house with government employees has several tangible benefits for the Army. It enables the Army more readily to manage the function if all personnel are directly and clearly subject to the chain of command, and other administrative and/or criminal sanctions, and it allows the function to be directly accessible by the commander/supervisor without going through a Contracting Officer Representative (COR). In addition, performing the function in-house enables Army Commanders to maintain a consistent approach to training (See Paragraph 3.b.(3)) and a reliable measure of the qualifications of the people performing the function.

(4) (U) If it is necessary to contract for interrogator services, Army requiring activities must carefully develop the applicable SOW to include the technical requirements and requisite personnel qualifications, experience, and training. Any such contracts should, to the greatest extent possible, be awarded and administered by an Army contracting activity in order to provide for the necessary oversight, management, and chain of command. Use of contracting vehicles

SECRET//NOFORN//X1

SECRET//NOFORN//X1

SUBJECT: (U) AR 15-6 Investigation of the Abu Ghraib Detention Facility and
205th MI Brigade

such as GSA Federal Supply Schedule (FSS) contracts should be carefully scrutinized given the complexity and sensitivities connected to interrogation operations.

(5) (U) Some of the employees at Abu Ghraib were not DoD contractor employees. Contractor employees under non-DoD contracts may not be subject to the Military Extraterritorial Jurisdiction Act (18 US Code 3261- 3267). The Act allows DoD contractor employees who are “accompanying the Armed Forces outside the United States” to be subject to criminal prosecution if they engage in conduct that would constitute an offense punishable by imprisonment for more than one year if the conduct had occurred within the jurisdiction of the United States.

(6) (U) In the performance of such sensitive functions as interrogation, the Army needs to maintain close control over the entire operation. If a decision is made to contract for these services, the most effective way to do that and maintain a direct chain of command is to award, administer, and manage the contract with Army personnel. As learned in the current situation, it is very difficult, if not impossible, to effectively administer a contract when the COR is not on site.

(7) (U) The Army needs to improve on-site contract monitoring by government employees (using CORs) to insure that the Army’s basic interests are protected. The inadequacy of the on-site contract management at Abu Ghraib is best understood by reviewing the statement of CPT Wood (Reference Annex B, Appendix 1, WOOD), the Interrogation OIC, who indicated she never received any parameters or guidance as to how the CACI personnel were to be utilized. She also indicates that her primary point of contact (POC) on matters involving the CACI Delivery Orders was the CACI on-site manager. There is no mention of a COR. Another indication of the inadequacy of the contract management is reflected in the statement of SOLDIER14 (Reference Annex B, Appendix 1, SOLDIER-14), who indicated he was never informed that the Government could reject unsatisfactory CACI employees. It would appear that no effort to familiarize the ultimate user of the contracted services of the contract’s terms and procedures was ever made. In order to improve this situation, training is required to ensure that the COR is thoroughly familiar with the contract and gains some level of familiarity with the Geneva Conventions standards. It needs to be made clear that contractor employees are bound by the requirements of the Geneva Conventions.

(8) (U) If it is necessary to contract for interrogator services, more specific training requirements and personnel standards must be incorporated into the solicitation/contract to insure that the contractor hires properly trained and qualified personnel.

(9) (U) Emerging results from a DA Inspector General (DAIG) Investigation indicate that approximately 35% of the contract interrogators lacked formal military training as interrogators.

SECRET//NOFORN//X1

~~SECRET//NOFORN//X1~~

SUBJECT: (U) AR 15-6 Investigation of the Abu Ghraib Detention Facility and
205th MI Brigade

While there are specific technical requirements in the linguist contract, the technical requirements for the interrogator contract were not adequate. It appears that the only mention of qualifications in the contract stated merely that the contractor employee needs to have met the requirements of one of two MOS, 97E or 351E, or "equivalent". Any solicitation/contract for these services needs to list specific training, if possible, not just point to an MOS. If the training from the MOS is what is required, those requirements should be listed in the solicitation/contract in full, not just referenced. Perhaps the best way of insuring that contractor interrogators receive adequate training would be to utilize existing government training. For example, prospective contractor employees could be sent, at contractor expense, to the Tactical Human Intelligence Course for the 97E MOS, "Human Intelligence Collector." Such a step would likely require some adjustments to the current program of instruction. Prospective contract interrogators could be given the course tests on Interrogation and the Geneva Conventions. If they can pass the examinations, no further training would be required. After a reasonable training period, prospective contractor interrogators who are unable to pass the exam would be rejected. There are, of course other training possibilities. The key point would be agreement on some standardization of the training of contractor interrogators. The necessity for some sort of standard training and/or experience is made evident by the statements of both contractor employees and military personnel. CIVILIAN-21 (CACI) seemingly had little or no interrogator experience prior to coming to Abu Ghraib (Reference Annex B, Appendix 1, CIVILIAN-21, ADAMS), even though he was a Navy Reserve Intelligence Specialist. Likewise, numerous statements indicated that little, if any, training on Geneva Conventions was presented to contractor employees (Reference Annex B, Appendix 1, SOLDIER-25, CIVILIAN-10, CIVILIAN-21 and CIVILIAN-11). Prior to deployment, all contractor linguists or interrogators should receive training in the Geneva Conventions standards for the treatment of detainees/prisoners. This training should include a discussion of the chain of command and the establishment of some sort of "hotline" where suspected abuses can be reported in addition to reporting through the chain of command. If the solicitation/contract allows "equivalent" training and experience, the Contracting Officer, with the assistance of technical personnel, must evaluate and assess the offerors'/contractor's proposal/written rationale as to why it believes that the employee has "equivalent" training. It appears that under the CACI contract, no one was monitoring the contractor's decisions as to what was considered "equivalent."

(10) (U) In addition, if functions such as these are being contracted, MI personnel need to have at least a basic level of contract training so they can protect the Army's interests. Another indication of the apparent inadequacy of on-site contract management and lack of contract training is the apparent lack of understanding of the appropriate relationship between contractor personnel, government civilian employees, and military personnel. Several people indicated in their statements that contractor personnel were "supervising" government personnel or *vice versa*. SGT Adams indicated that CACI employees were in positions of authority, and appeared to be supervising government personnel. She indicated a CACI employee named "First Name"

~~SECRET//NOFORN//X1~~

SECRET//NOFORN//X1

SUBJECT: (U) AR 15-6 Investigation of the Abu Ghraib Detention Facility and
205th MI Brigade

was listed as being in charge of screening. CIVILIAN-08 (CACI) was in charge of "B Section" with military personnel listed as subordinates on the organization chart. SOLDIER-14 also indicated that CIVILIAN-08 was a supervisor for a time. CPT Wood stated that CACI "supervised" military personnel in her statement, but offered no specifics. Finally, a government organization chart (Reference Annex H, Appendix 6, Tab B) showed a CIVILIAN-02 (CACI) as the Head of the DAB. CIVILIAN-02 is a CACI employee. On the other side of the coin, CIVILIAN-21 indicated in his statement that the Non-Commissioned Officer in Charge (NCOIC) was his supervisor. (Reference Annex B, Appendix 1, SOLDIER-14, CIVILIAN-21, ADAMS, WOOD)

(11) (U) Given the sensitive nature of these sorts of functions, it should be required that the contractor perform some sort of background investigation on the prospective employees. A clause that would allow the government to direct the contractor to remove employees from the theater for misconduct would seem advisable. The need for a more extensive pre-performance background investigation is borne out by the allegations of abuse by contractor personnel.

(12) (U) An important step in precluding the recurrence of situations where contractor personnel may engage in abuse of prisoners is to insure that a properly trained COR is on-site. Meaningful contract administration and monitoring will not be possible if a small number of CORs are asked to monitor the performance of one or more contractors who may have 100 or more employees in the theater, and in some cases, perhaps in several locations (which seems to have been the situation at Abu Ghraib). In these cases, the CORs do well to keep up with the paper work, and simply have no time to actively monitor contractor performance. It is apparent that there was no credible exercise of appropriate oversight of contract performance at Abu Ghraib.

(13) (U) Proper oversight did not occur at Abu Ghraib due to a lack of training and inadequate contract management and monitoring. Failure to assign an adequate number of CORs to the area of contract performance puts the Army at risk of being unable to control poor performance or become aware of possible misconduct by contractor personnel. This lack of monitoring was a contributing factor to the problems that were experienced with the performance of the contractors at Abu Ghraib. The Army needs to take a much more aggressive approach to contract administration and management if interrogator services are to be contracted. Some amount of advance planning should be utilized to learn from the mistakes made at Abu Ghraib.

h. (U) Other Government Agencies and Abu Ghraib.

(1) (U) Although the FBI, JTF-121, Criminal Investigative Task Force, ISG and the Central Intelligence Agency (CIA) were all present at Abu Ghraib, the acronym "Other Government Agency" (OGA) referred almost exclusively to the CIA. CIA detention and interrogation

SECRET//NOFORN//X1

~~SECRET//NOFORN//X1~~

SUBJECT: (U) AR 15-6 Investigation of the Abu Ghraib Detention Facility and
205th MI Brigade

practices led to a loss of accountability, abuse, reduced interagency cooperation, and an unhealthy mystique that further poisoned the atmosphere at Abu Ghraib.

(2) (U) CIA detainees in Abu Ghraib, known locally as "Ghost Detainees," were not accounted for in the detention system. When the detainees were unidentified or unaccounted for, detention operations at large were impacted because personnel at the operations level were uncertain how to report them or how to classify them, or how to database them, if at all. Therefore, Abu Ghraib personnel were unable to respond to requests for information about CIA detainees from higher headquarters. This confusion arose because the CIA did not follow the established procedures for detainee in-processing, such as fully identifying detainees by name, biometric data, and Internee Serial Number (ISN) number.

(3) (U) DETAINEE-28, suspected of having been involved in an attack against the ICRC, was captured by Navy SEAL Team 7 during a joint TF-121/CIA mission. He reportedly resisted arrest, so a SEAL Team member butt-stroked DETAINEE-28 on the side of the head to subdue him. CIA representatives brought DETAINEE-28 into Abu Ghraib early in the morning of 4 November 2003, sometime around 0430 to 0530 hours. Under a supposed verbal agreement between the JIDC and the CIA, the CIA did not announce its arrival to JIDC Operations. SPC Stevanus, the MP on duty at the Hard Site at the time, observed the two CIA representatives come in with DETAINEE-28 and place him in a shower room in Tier 1B. About 30 to 45 minutes later, SPC Stevanus was summoned to the shower stall and when he arrived, DETAINEE-28 appeared to be dead. Removing the sandbag covering DETAINEE-28's head, SPC Stevanus checked DETAINEE-28's pulse. Finding none, he called for medical assistance, and notified his chain of command. LTC Jordan arrived on site at approximately 0715 hours, and found several MPs and US medical staff with DETAINEE-28 in the Tier 1B shower stall, face down, handcuffed with his hands behind his back. CIVILIAN-03, an Iraqi prison medical doctor, informed him DETAINEE-28 was dead. "OTHER AGENCY EMPLOYEE01," a CIA representative, un-cuffed DETAINEE-28 and turned his body over. Where DETAINEE-28's head had lain against the floor, LTC Jordan noted a small spot of blood. LTC Jordan notified COL Pappas (205 MI BDE Commander), and "OTHER AGENCY EMPLOYEE01" said he would notify "OTHER AGENCY EMPLOYEE02," his CIA supervisor. Once "OTHER AGENCY EMPLOYEE02" arrived, he requested that the Hard Site hold DETAINEE28's body until the following day. DETAINEE-28's body was placed in a body bag, packed in ice, and stored in the shower area. CID was notified. The next day, DETAINEE-28's body was removed from Abu Ghraib on a litter, to make it appear as if he were only ill, so as not to draw the attention of the Iraqi guards and detainees. The body was transported to the morgue at BIAP for an autopsy, which concluded that DETAINEE-28 died of a blood clot in the head, likely a result of injuries he sustained during apprehension. (Reference Annex B, Appendix 1, JORDAN, PAPPAS, PHILLABAUM, SNIDER, STEVANUS, THOMPSON; Annex I, Appendix 1, photographs C5-21, D5-11, M65-69)

~~SECRET//NOFORN//X1~~

SECRET//NOFORN//X1

SUBJECT: (U) AR 15-6 Investigation of the Abu Ghraib Detention Facility and
205th MI Brigade

(4) (U) The systemic lack of accountability for interrogator actions and detainees plagued detainee operations in Abu Ghraib. It is unclear how and under what authority the CIA could place prisoners like DETAINEE-28 in Abu Ghraib because no memorandums of understanding existed on the subject between the CIA and CJTF-7. Local CIA officers convinced COL Pappas and LTC Jordan that they should be allowed to operate outside the established local rules and procedures. When COL Pappas raised the issue of CIA use of Abu Ghraib with COL Boltz, COL Boltz encouraged COL Pappas to cooperate with the CIA because everyone was all one team. COL Boltz directed LTC Jordan to cooperate. (Reference Annex B, Appendix 1, PAPPAS, BOLTZ)

(5) (U) In many instances, failure to adhere to in-processing procedures caused confusion and acrimony between the Army and OGA, and in at least one instance, acrimony between the US and Saudi Arabian entities. (Reference Annex K, Appendix 3, emails) For example, the CIA interned three Saudi national medical personnel working for the coalition in Iraq. CIA officers placed them in Abu Ghraib under false names. The Saudi General in charge of the men asked US authorities to check the records for them. A search of all databases using their true names came back negative. Ambassador Bremer then requested a search, which produced the same results. The US Embassy in Riyadh also requested a search, which likewise produced no information. Ultimately, the Secretary of State, Colin Powell, requested a search, and as with the other requestors, had to be told that the three men were not known to be in US custody. Shortly after the search for the Secretary of State, a JIDC official recalled that CIA officers once brought three men together into the facility. A quick discussion with the detainees disclosed their true names, which matched the name search requests, and the men were eventually released. (Reference Annex B, Appendix 1, CIVILIAN-12)

(6) (U) Another instance showing lack of accountability to the procedures or rules involved a CIA officer who entered the interrogation room after a break in the interrogation, drew his weapon, chambered a round, and placed the weapon in his holster. This action violated the rule that no weapons be brought into an interrogation room, especially weapons with live rounds. Detainees who have been interrogated by CIA officers have alleged abuse. (Reference Annex B, Appendix 1, CIVILIAN-12)

(7) (U) The death of DETAINEE-28 and incidents such as the loaded weapon in the interrogation room, were widely known within the US community (MI and MP alike) at Abu Ghraib. Speculation and resentment grew over the lack of personal responsibility, of some people being above the laws and regulations. The resentment contributed to the unhealthy environment that existed at Abu Ghraib. The DETAINEE-28 death remains unresolved. CIA officers operating at Abu Ghraib used alias' and never revealed their true names. "OTHER AGENCY EMPLOYEE01" (alias) was the CIA officer with DETAINEE-28 on the morning of

SECRET//NOFORN//X1

SECRET//NOFORN//X1

SUBJECT: (U) AR 15-6 Investigation of the Abu Ghraib Detention Facility and
205th MI Brigade

his death. "OTHER AGENCY EMPLOYEE02" (alias) was not directly involved in DETAINEE-28's death, but participated in the discussions after his death. Had the CIA followed established Army procedures and in-processed DETAINEE-28 in accordance with those procedures, DETAINEE-28 would have been medically screened.

(8) (U) OGA never provided results of their abuse investigations to Commander, CJTF-7. This resulted in a total lack of visibility over OGA interaction with detainees held in CJTF-7 spaces. Additionally, the CJTF-7 charter provided no oversight or control over the ISG. LTG Sanchez could neither leverage ISG interrogation assets to assist the detainee operations in Abu Ghraib, nor could he compel ISG to share substantive intelligence reports with CJTF-7. (Reference Annex B, Appendix 1, SANCHEZ)

i. (U) The Move of the 205 MI BDE Commander to Abu Ghraib.

(1) (U) In September 2003, COL Pappas began visiting Abu Ghraib two or three times per week as opposed to once every week or two, his previous routine. He was also beginning to stay overnight occasionally. His visit schedule coincided with the increased emphasis being placed on interrogation operations and the newly formed JIDC. (Reference Annex B, Appendix 1, PAPPAS)

(2) (U) On 16 November 2003, COL Pappas took up full time residence at Abu Ghraib after once again speaking with LTG Sanchez and MG Fast and deciding that he needed to be there. He was appointed FOB Commander on 19 November 2003 in FRAGO 1108. The issuance of FRAGO 1108 has been pointed to and looked upon by many as being a significant change and one that was a major factor in allowing the abuses to occur. It was not. The abuses and the environment for them began long before FRAGO 1108 was ever issued. That FRAGO appointed the Commander, 205 MI BDE, the Commander FOB Abu Ghraib for Force Protection and Security of Detainees. COL Pappas then had TACON of the 320 MP BN. TACON has been misinterpreted by some to mean that COL Pappas then took over the running of the prison, or what has been referred to as Warden functions. COL Pappas never took over those functions, and LTC Phillabaum agrees that the running of the prison was always his responsibility. LTG Sanchez has stated that he never intended to do anything except improve the Force Protection posture of the FOB. That improved force protection posture would have thus improved the security of detainees as well. COL Pappas' rater, MG Wojdakowski, also stated that COL Pappas was never given responsibility for running the prison, but that the MPs retained that responsibility. It would appear from MG Taguba's investigation and the interview for this investigation that BG Karpinski was the only person among the Army leadership involved at the time who interpreted that FRAGO differently. (Reference Annex B, Appendix 1, KARPINSKI and Annex B, Appendix 2, KARPINSKI)

SECRET//NOFORN//X1

~~SECRET//NOFORN//X1~~

SUBJECT: (U) AR 15-6 Investigation of the Abu Ghraib Detention Facility and
205th MI Brigade

(3) (U) Upon being appointed FOB Commander, COL Pappas brought in one of his subordinate units, the 165th MI Battalion (165 MI BN) to enhance base security and to augment forces providing perimeter security as well as to conduct reconnaissance and surveillance outside the perimeter. That unit had reconnaissance and surveillance elements similar to line combat units that the MP Battalions did not possess. COL Pappas, on 8 December 2003, requested additional forces to support his force protection mission (Reference Annex H, Appendix 6, TAB – Request for Forces (RFF)). Requested forces included personnel for additional guards and a rapid reaction force.

(4) (U) The fact that COL Pappas did not have control of the MP force after the 19 November 2003 FRAGO regarding prison operations is further supported by the fact that at some point near the end of November 2003, the MPs stopped escorting detainees from the camps to the interrogation sites due to personnel shortages. This required MI to take over this function despite their protests that they were neither trained nor manned to do it. COL Pappas would have ordered the MPs to continue the escorts if he had had such authority (See paragraph 4.c.)

(5) (U) A milestone event at Abu Ghraib was the shooting incident that occurred in Tier 1A on 24 November 2003 (See paragraph 5.e.). COL Pappas was by then in residence at Abu Ghraib. LTC Jordan displayed personal bravery by his direct involvement in the shoot-out, but also extremely poor judgment. Instead of ordering the MPs present to halt their actions and isolate the tier until the 320 MP BN Commander and COL Pappas could be notified, he became directly involved. As the senior officer present, LTC Jordan became responsible for what happened. Eventually, COL Pappas was notified, and he did visit the scene. By then the shooting was over, and the MPs were searching the cells. COL Pappas did not remain long but admits to being told by SOLDIER-23 that the Iraqi Police were being interrogated by MI personnel. COL Pappas left LTC Jordan in charge of the situation after the shooting which came to be known as the IP Roundup. The IP Roundup was, by all accounts chaotic. The Iraqi Police, hence the name "IP," became detainees and were subjected to strip searching by the MPs in the hallway, with female Soldiers and at least one female interpreter present. The IP were kept in various stages of dress, including nakedness, for prolonged periods as they were interrogated. This constitutes humiliation, which is detainee abuse. Military working dogs were being used not only to search the cells, but also to intimidate the IPs during interrogation without authorization. There was a general understanding among the MI personnel present that LTG Sanchez had authorized suspending existing ICRP (known by the Abu Ghraib personnel locally as the IROE) because of the shooting (Reference Annex C, Appendix 1, Tab B, Annex 8, AR 15-6 Investigation, 24 November 2003). Nobody is sure where that information came from, but LTG Sanchez never gave such authorization (Reference Annex B, Appendix 1, SANCHEZ). LTC Jordan and the Soldiers should have known the Interrogation Rules would not and could not have been suspended. LTC Jordan should have controlled the situation and should have taken steps to reinforce proper standards at a time when emotions were likely high given the

~~SECRET//NOFORN//X1~~

SECRET//NOFORN//X1

SUBJECT: (U) AR 15-6 Investigation of the Abu Ghraib Detention Facility and
205th MI Brigade

circumstances. LTC Jordan is responsible for allowing the chaotic situation, the unauthorized nakedness and resultant humiliation, and the military working dog abuses that occurred that night. LTC Jordan should have obtained any authorizations to suspend ICRP in writing, via email, if by no other means. The tone and the environment that occurred that night, with the tacit approval of LTC Jordan, can be pointed to as the causative factor that set the stage for the abuses that followed for days afterward related to the shooting and the IP Roundup. COL Pappas is also responsible and showed poor judgment by leaving the scene before normalcy returned, as well as for leaving LTC Jordan in charge.

(6) (U) The small quantity of MI personnel had a difficult time managing the large number of MI holds which moved from the hundreds to over a thousand by December 2003 (See paragraph 4.c.(12)). In December 2003, COL Pappas, in his role as FOB Commander, requested additional forces be allocated to support the difficult and growing force protection mission. Prior to his designation as FOB Commander, COL Pappas had requested additional forces to support the JIDC mission. One of the reasons he cited in the December request was that the mixing of MI and MP functions was worsening the already difficult personnel resource situation.

j. (U) Advisory and Training Team Deployments

(1) (U) MG Geoffrey Miller Visit

(a) (U) MG G. Miller's visit was in response to a J3, JCS, request to SOUTHCOM for a team to assist CENTCOM and ISG in theater (Reference Annex L, Appendix 1, Electrical Message, DTG: 181854Z Aug 03, FM JOINT STAFF WASHINGTON DC // J3). The team was directed to assist with advice on facilities and operations specific to screening, interrogations, HUMINT collection, and interagency integration in the short and long term. MG G. Miller was tasked as the result of a May 2003 meeting he had with MG Ronald Burgess, J2, JCS. MG Burgess indicated there were some challenges in CJTF-7 with the transition from major combat operations to SASO in the areas of intelligence, interrogation, and detention (Reference Annex B, Appendix 1, MILLER). COL Boltz believed LTG Sanchez had requested the support (Reference Annex B, Appendix 1, BOLTZ).

(b) (U) From 31 August to 9 September 2003, MG G. Miller led a team to Iraq to conduct an "Assessment of DoD Counterterrorism Interrogation and Detention Operations in Iraq." Specifically, MG G. Miller's team was to conduct assistance visits to CJTF-7, TF-20, and the ISG to discuss current theater ability to exploit internees rapidly for actionable intelligence. MG G. Miller and his team of 17 experts assessed three major areas of concern: intelligence integration, synchronization, and fusion; interrogation operations; and detention operations. The team's assessment (Reference Annex L, Appendix 1, MG Miller's Report, Assessment of DoD Counterterrorism Interrogation and Detention Operations in Iraq, undated, and MG Miller's

SECRET//NOFORN//X1

~~SECRET//NOFORN//X1~~

SUBJECT: (U) AR 15-6 Investigation of the Abu Ghraib Detention Facility and
205th MI Brigade

Briefing of his findings, dated 6 September 2003) identified several areas in need of attention: the interrogators didn't have the authorities and procedures in place to effect a unified strategy to detain, interrogate, and report information from detainees in Iraq; the information needs required an in-theater analysis capability integrated in the interrogation operations to allow for access/leverage of the worldwide intelligence databases; and the detention operations function must support the interrogation process.

(c) (U) MG G. Miller's visit also introduced written GTMO documentation into the CJTF-7 environment. LTG Sanchez recalled MG G. Miller left behind a whole series of SOPs that could be used as a start point for CJTF-7 interrogation operations. It was clear that these SOPs had to be adapted to the conditions in Iraq and that they could not be implemented blindly. LTG Sanchez was confident the entire CJTF-7 staff understood that the conditions in GTMO were different than in Iraq, because the Geneva Conventions applied in the Iraqi theater.

(d) (U) The assessment team essentially conducted a systems analysis of the intelligence mission in Iraq and did not concentrate on specific interrogation techniques. While no "harsh techniques" were briefed, COL Pappas recalled a conversation with MG G. Miller regarding the use of military working dogs to support interrogations (See paragraph 5.f.). According to COL Pappas, MG G. Miller said they, GTMO, used military working dogs, and that they were effective in setting the atmosphere for interrogations (Reference Annex B, Appendix 2, PAPPAS). MG G. Miller contradicted COL Pappas in his statement (Reference Annex B, Appendix 1, MILLER), saying he only discussed using military working dogs to help the MPs with detainee custody and control issues. According to MG G. Miller, the dogs help provide a controlled atmosphere (not interrogations as recalled by COL Pappas) that helps reduce risk of detainee demonstrations or acts of violence. According to MG G. Miller, his team recommended a strategy to work the operational schedule of the dog teams so the dogs were present when the detainees were awake, not when they are sleeping.

(e) (U) Several things occurred subsequent to MG G. Miller's visit to Abu Ghraib. The JIDC was established. The use of Tiger Teams was implemented based on the JTF-GTMO model, which teamed an interrogator and an analyst together, giving each team an organic analytical capability. There was also a moderate increase in the number of interrogators reassigned to the Abu Ghraib operation. This increase was probably not connected to MG G. Miller's visit as much as to the arrival of elements of the 325 MI BN which began to arrive 10 September 2003--the same day MG G. Miller departed Iraq. Prior to their arrival, the interrogation assets consisted of one OIC (captain), one technician (chief warrant officer), 12 HUMINT collectors (MOS 97E/97B), an analyst, and a communications team. While the number of interrogators increased, the JIDC requirements for a staff and leadership also increased. Those positions were filled from within the assigned units. It is indeterminate what impact the MG G. Miller Team's concepts had on operations at Abu Ghraib. There was an

~~SECRET//NOFORN//X1~~

SECRET//NOFORN//X1

SUBJECT: (U) AR 15-6 Investigation of the Abu Ghraib Detention Facility and
205th MI Brigade

increase in intelligence reports after the visit but that appears more likely due to the assignment of trained interrogators and an increased number of MI Hold detainees to interrogate.

(2) JTF-GTMO Training Team.

(a) (U) Subsequent to MG G. Miller's visit, a team of subject matter experts was dispatched from JTF-GTMO to Abu Ghraib (approximately 4 October to 2 December 2003) to assist in the implementation of the recommendations identified by MG G. Miller. The JTF-GTMO Team included three interrogators and three analysts, organized into three teams, with one interrogator and one analyst on each, which is the GTMO "Tiger Team" concept. The JTF GTMO Team included SOLDIER28 (351E Team Chief), SOLDIER27, CIVILIAN-14 (97E), SOLDIER-03 (97E), SSG Miller (96B), and SOLDIER-11 (96B). The Team Chief understood his task was to assist CJTF-7 for a period not to exceed 90 days with the mission of building a robust and effective JIDC, and identifying solutions and providing recommendations for the JIDC (Reference Annex B, Appendix 1, SOLDIER-28). Upon arrival at Abu Ghraib, SOLDIER-28 and SOLDIER-27, both of whom had been on the original MG G. Miller assessment visit, concentrated on establishing the various JIDC elements. Particular emphasis was given to formalizing the JIDC staff and the collection, management and dissemination (CM&D) function at Abu Ghraib, to alleviate many of the information distribution issues surfaced during MG G. Miller's visit. Some interrogation policies were already in place. Consistent with its charter to assist in establishment of a GTMO-like operation, the team provided copies of the current JTF-GTMO policies, SOPs (Reference, Annex L, Appendix 2, SOP for JTF-GTMO, Joint Intelligence Group [JIG], Interrogation Control Element [ICE], Guantanamo Bay, CU, dated 21 January 2003, revised 12 June 2003), and the SECDEF Letter (Reference, Annex J, Appendix 2, MEMORANDUM FOR COMMANDER, US SOUTHERN COMMAND, Subject: Counter-Resistance Techniques in the War on Terrorism (S), dated 16 April 2003) outlining the techniques authorized for use with the GTMO detainees. The four other JTF-GTMO team members were split up and integrated into interrogation operations as members/leaders of the newly formed Tiger Teams under the ICE. SOLDIER-28 and SOLDIER-27 did not directly participate in any interrogation operations and reported that they never observed, or heard about, any detainee abuse or mistreatment. SOLDIER-28's assertion as regards knowledge of abuses is contradicted by one of his Soldiers (Reference Annex B, Appendix 1, SOLDIER-03) (See paragraphs 4.j.(2)(c) and 4.j.(2)(d), below).

(b) (U) While the JTF-GTMO team's mission was to support operations and assist in establishment of the JIDC, there was a great deal of animosity on the part of the Abu Ghraib personnel, especially some A/519 MI BN Personnel. This included an intentional disregard for the concepts and techniques the GTMO Team attempted to instill, as well as contempt for some of the team's work ethic, professional judgment, and ideas. Because of this, the GTMO Team's ability to effect change at Abu Ghraib may have been severely limited. This information was

SECRET//NOFORN//X1

SECRET//NOFORN//X1

SUBJECT: (U) AR 15-6 Investigation of the Abu Ghraib Detention Facility and
205th MI Brigade

obtained during a review of email exchanged between SOLDIER-14, CW2 Grace, CW3 Sammons, SFC McBride, with info copies to CPT Wood and SOLDIER-23. It should be noted that senior managers at Abu Ghraib thought highly of the JTF-GTMO team and believed they positively impacted the operations.

(c) (U) SOLDIER-11, a JTF-GTMO analyst assigned to the "Former Regime Loyalists" Tiger Team, stated that he witnessed and reported two incidents of abuse (Reference Annex B, Appendix 1, SOLDIER-11). In his first report, SOLDIER-11 reported that he was observing an interrogation being conducted by SOLDIER19 A/519 MI BN. As SOLDIER-11 observed from behind a glass, SOLDIER-19 directed a detainee to roll his jumpsuit down to his waist and insinuated that the detainee would be stripped further if he did not cooperate. The interrogation ended abruptly when the translator objected to the tactic and refused to continue. SOLDIER-11 reported the incident to both SOLDIER-16, his Tiger Team Leader, and to SOLDIER-28, his JTF GTMO Team Chief. SOLDIER-16 invoked her rights under UCMJ and chose not to make any statement regarding this or any other matters (Reference Annex B, Appendix 1 SOLDIER16). When asked, SOLDIER-28 stated that he could not recall what SOLDIER11 reported to him regarding the rolling down of the detainee's jumpsuit, but does recall a conversation about a translator walking out of an interrogation due to a "cultural difference" (Reference Annex B, Appendix 1, SOLDIER-28). SOLDIER-11 is adamant that he reported the incident in detail (Reference Annex B, Appendix 1, SOLDIER-11) and that he never used the phrase "cultural difference."

(d) (U) In another report to SOLDIER-28, SOLDIER-11 reported a second incident. SOLDIER-11 and SOLDIER--19 were conducting an interrogation around mid-October 2003. The detainee was uncooperative and was not answering questions. SOLDIER19 became frustrated and suggested to SOLDIER11 that the detainee be placed in solitary. SOLDIER-11 did not agree with the recommendation and suggested it would be counterproductive. About 15 minutes later (two hours into the interrogation), SOLDIER-19 exercised his authority as the lead interrogator and had the detainee placed in solitary confinement. About a half an hour later, SOLDIER-11 and SOLDIER-19 went to the Hard Site to see the detainee, and found him lying on the floor, completely naked except for a hood that covered his head from his upper lip, whimpering. SOLDIER-11 and SOLDIER-19 had the MPs redress the detainee before escorting him back to the general population. SOLDIER-11 was disturbed by what he had seen and considered reporting it to several different people. Ultimately, SOLDIER-11 reported this incident to SOLDIER-28 (Reference Annex B, Appendix 1, SOLDIER-11). SOLDIER-11 added that SOLDIER-28 accepted the report and indicated he would surface the issue to COL Pappas (not due to return to Abu Ghraib for 2 - 3 days). Also according to SOLDIER-11, SOLDIER-28 was very ill and placed on 30 days quarters shortly after SOLDIER-11 made his report. When asked, SOLDIER-28 could not recall such a report being made to him (Reference Annex B, Appendix 1, SOLDIER-28).

SECRET//NOFORN//X1

SECRET//NOFORN//X1

SUBJECT: (U) AR 15-6 Investigation of the Abu Ghraib Detention Facility and
205th MI Brigade

(e) (U) SSG Miller does not recall the JTF-GTMO team ever discussing specific interrogation techniques employed, abuse, or unauthorized interrogation methods. He observed only approved interrogation techniques in line with FM 34-52, and never saw any detainee abuse, mistreatment, or nakedness (Reference Annex B, Appendix 1, MILLER).

(f) (U) CIVILIAN-14 never observed any activity or training event that was not in compliance with basic human rights and the Geneva Conventions. CIVILIAN-14 did, however, notice "a lot of detainee nakedness at Abu Ghraib," possibly, he speculated, attributable to the lack of available clothing. There was nothing he observed or heard that he considered detainee abuse. Relating to his JTF-GTMO experience/training, CIVILIAN-14 believed the removal of clothing for interrogation purposes was an option available with the appropriate approvals; however, it was rarely used at JTF-GTMO. This misunderstanding of the rules and regulations was evident in his reaction to the detainee nakedness at Abu Ghraib. Clearly CIVILIAN-14 was not aware of the fact the SECDEF had withdrawn that authority. (Reference Annex B, Appendix 1, CIVILIAN-14)

(g) (U) In reviewing his activities while at Abu Ghraib, SOLDIER-03 recalled his team submitted two requests to use techniques requiring approvals beyond the team level. In cases requiring such approvals, the request went to the Operations Officer (either MAJ Thompson or MAJ Price) (Operations Officer) and they would approve or disapprove the technique. Those requests requiring a CJTF-7 approval level went to CPT Wood who would forward them for approval. SOLDIER-03 recalled submitting the requests several days in advance of the interrogation to ensure it was approved or disapproved before the interrogation began. His first request (detainee sitting against a wall) was initiated by SOLDIER-21 (analyst) and SOLDIER-30 (interrogator). SOLDIER-03 reviewed the request and forwarded it for approval (SOLDIER-03 could not recall to whom he submitted the request or who had approved it). The request was approved and was implemented. After "observing for a couple of minutes," SOLDIER-03 ended the interrogation. In preparation for another interrogation, the same two females (SOLDIER-21 and SOLDIER-30) submitted a request to interrogate a detainee naked. The request was reviewed by SOLDIER-03 and forwarded to MAJ Price. MAJ Price denies ever approving a naked interrogation. SOLDIER-03 recalled that the technique had been approved, but could not recall by whom. As with the above interrogation, SOLDIER-03 observed the interrogation. After about 15 minutes, he determined the nudity was not a productive technique and terminated the session. SOLDIER-03 never discussed this incident with SOLDIER-28. In his opinion, he had obtained the appropriate authorities and approvals for an "acceptable technique." When asked, SOLDIER-03 recalled hearing about nakedness at GTMO, but never employed the technique. (Reference Annex B, Appendix 1, SOLDIER-03, PRICE).

(h) (U) The JTF-GTMO Team viewed itself as having the mission of setting up and organizing an effective and efficient JIDC staff, and assisting in establishing the Tiger Team

SECRET//NOFORN//X1

SECRET//NOFORN//X1

SUBJECT: (U) AR 15-6 Investigation of the Abu Ghraib Detention Facility and
205th MI Brigade

concept based on the GTMO model and experience. They did not view their mission as being for training specific interrogation techniques. This is contrary to MG G. Miller's understanding of the mission. There is no evidence that the JTF-GTMO team intentionally introduced any new/prohibited interrogation techniques. Clearly, however, they were operating without a full understanding of the current JTF-GTMO ICRP.

(i) (U) According to SOLDIER-28, no After Action Report (AAR) was prepared for this mobile training team's effort. He provided a post-mission briefing to MG G. Miller upon his return to GTMO. The team's mission was not clearly defined until they arrived at Abu Ghraib. According to MAJ Price (Reference Annex B, Appendix 1, PRICE), the JTF-GTMO Team arrived without a defined charter; however, in his opinion, the team's suggestions were very good and exactly what the Abu Ghraib operation needed. MAJ Price felt that the real changes began to show after COL Pappas arrived on or about 16 November 2003.

(3) (U) Fort Huachuca Mobile Training Team

(a) (U) From 7 to 21 October 2003, a five person ISCT MTT from the USAIC, Fort Huachuca, AZ, was dispatched to conduct an overall assessment of interrogation operations, present training, and provide advice and assistance at the Abu Ghraib JIDC. This course was developed in response to requirements surfaced during interrogation operations at JTF-GTMO, specifically to prepare reserve interrogators and order of battle analysts for deployment to JTF-GTMO. The course consists of a refresher in interrogation procedures and an introduction to strategic debriefing procedures (Reference Annex L, Appendix 4, ISCT POI; ISCT MTT AAR). The MTT consisted of a team chief, CW3 Norris (351B), three 97E interrogators, MSG Filhanessian, SFC Fierro and SFC Walters, and one analyst (96B) SOLDIER-56. The MTT spent the first few days at Abu Ghraib observing ongoing JIDC interrogation operations and establishing a training schedule based on their observations. The training phase lasted approximately five days and focused on interrogation skills and elicitation techniques, cultural awareness, collection management, and use of interpreters. The team discussed the use of Tiger Teams, but did not conduct any training in their use. The Tiger Team concept of teaming an Interrogator and an Analyst together had been previously recommended by the GTMO Assessment Team and was already being employed at Abu Ghraib when the ISCT MTT arrived. Following the training, at least two ISCT MTT Interrogators participated in approximately 19 interrogations and observed several others. The MTT prepared an After Action Report (Reference Annex L, Appendix 4, ISCT MTT AAT, Joint Detainee Interrogation Center, CJTF-7, Abu Ghurayb (sic), Iraq, dated 3 November 2003), which noted eleven issues and provided recommendations for each. The issues mainly concerned screening procedures, interrogation planning and preparation, approaches, questioning, interpreter control, deception detection, and administrative and reporting issues. SFC Filhanessian did recall they had access to the 16 April 2003 SECDEF Memorandum and devoted some time to discussing approach strategies outside

SECRET//NOFORN//X1

SECRET//NOFORN//X1

SUBJECT: (U) AR 15-6 Investigation of the Abu Ghraib Detention Facility and
205th MI Brigade

the ones mentioned in FM 34-52, Intelligence Interrogations, 28 September 1992, like the issue of military working dogs, sleep deprivation, etc., (Reference Annex B, Appendix 1, FILHANESSIAN). According to SOLDIER-25 (Reference Annex B, Appendix 1, SOLDIER25), "A team from Fort Huachuca ... gave us 3 days of classes, including rules of engagement and the use of sleep deprivation and sleep management." The ISCT MTT AAR did not note any incidents of detainee abuse or mistreatment. Three interviewed ISCT MTT members stated that they did not witness, or hear of any incidents of detainee abuse or mistreatment. Neither did they observe or know of any incidents where MI instructed or insinuated that the MP should abuse detainees. Further, MTT members stated that the 519 MI BN interrogators at Abu Ghraib demonstrated experience, "did things by the book," and used techniques that were within the limitations established by FM 34-52 (Interrogation Operations). Some team members, however, expressed some concerns about what appeared to them to be a lack of experience with some of the civilian contracted CACI Interrogators, and the fact that the MTT did not have the opportunity to train and work with some newly arriving contractors (Reference Annex B, Appendix 1, WALTERS; CIVILIAN-07; and FIERRO).

(b) (U) On 21 June 2004, SFC Walters contacted the investigative team via email and indicated he wanted to make additions to his statement (Reference Annex B, Appendix 1, WALTERS 20040621, email). SFC Walters was concerned that as a member of the ISCT MTT, he may have contributed to the abuse at Abu Ghraib. When questioned by CACI employee CIVILIAN-21 for ideas to use to get these prisoners to talk, SFC Walters related several stories about the use of dogs as an inducement, suggesting he (CIVILIAN-21) talk to the MPs about the possibilities. SFC Walters further explained that detainees are most susceptible during the first few hours after capture. "The prisoners are captured by Soldiers, taken from their familiar surroundings, blindfolded and put into a truck and brought to this place (Abu Ghraib); and then they are pushed down a hall with guards barking orders and thrown into a cell, naked; and that not knowing what was going to happen or what the guards might do caused them extreme fear." SFC Walters also suggested CIVILIAN-21 could take some pictures of what seemed to be guards being rough with prisoners...so he could use them to scare the prisoners. Lastly, SFC Walters also shared what he described as a formal, professional prisoner in-processing as he observed it in Bagram (a reference to the detainee operations that had taken place Afghanistan).

(c) (U) On 26 June 2004, during a follow-on interview (Reference Annex B, Appendix 1, WALTERS); SFC Walters confirmed the information he provided in his email. He clarified that his conversation with CIVILIAN-21 occurred before the training was conducted and that he was certain CIVILIAN-21 clearly understood the rules with regard to interrogations. SFC Walters was adamant he had stressed the need to obtain the appropriate authorities before using any of the techniques discussed. SFC Walters knew of no other "off line" conversations between the MTT members and assigned interrogators. SFC Walters said he had related stories he had heard, but did not personally observe. In addressing the ISCT MTT training objectives, SFC

SECRET//NOFORN//X1

SECRET//NOFORN//X1

SUBJECT: (U) AR 15-6 Investigation of the Abu Ghraib Detention Facility and
205th MI Brigade

Walters noted they (ISCT MTT) did not agree with the JTF-GTMO modus operandi. The (ISCT MTT) felt the use of Tiger Teams wasted limited analytical support. Analysts should support interrogation teams and not be part of the interrogation. This mirrors the opinions of the Abu Ghraib team (Reference Annex B, Appendix 1, WOOD).

(d) (U) Throughout OIF I, USAIC assisted in sending MTTs to all divisional locations within Iraq in order to provide instruction on THT operations, G2X staff functions, and tactical questioning for non-military intelligence Soldiers. Prior to this training, a separate team traveled to Afghanistan and Iraq to provide similar training at Bagram Airfield and Abu Ghraib Detention Facility. This training was the same training provided to OIF units in Iraq that also incorporated lessons learned during that MTT.

k. (U) International Committee of the Red Cross (ICRC)

(1) (U) The ICRC visits to Abu Ghraib have been the source of great concern since the abuses at Abu Ghraib became public knowledge. The ICRC are independent observers who identified abuses to the leadership of Abu Ghraib as well as to CJTF-7. Their allegations were not believed, nor were they adequately investigated.

(2) (U) During the 9-12 and 21-23 October 2003 visits to Abu Ghraib, the ICRC noted that the ill treatment of detainees during interrogation was not systemic, except with regard to persons arrested in connection with suspected security offenses or deemed to have an "intelligence value." These individuals were probably the MI holds. "In these cases, persons deprived of their liberty [and] under supervision of the Military Intelligence were at high risk of being subjected to a variety of harsh treatments. These ranged from insults, threat and humiliations, to both physical and psychological coercion (which in some cases was tantamount to torture) in order to force cooperation with their interrogators (Reference Annex G, Appendix 1, Executive Summary)." The ICRC noted that some detainees in Tier 1A were held naked in their cells, with meals ready to eat (MRE) packing being used to cover their nudity. The ICRC immediately informed the authorities, and the detainees received clothes for the remainder of the ICRC visit. Additionally, the ICRC complained about MI-imposed restrictions on visiting certain security detainees in Camp Vigilant and in Tier 1A. Red Cross delegates were informed they could visit those areas the following day and then only on the basis of a list of detainees and tasks agreed on with Abu Ghraib officials. (Reference Annex G, Appendix 1, TAB B)

(3) (U) The ICRC found a high level of depression, feelings of helplessness, stress, and frustration, especially by those detainees in isolation. Detainees made the following allegations during interviews with the ICRC: threats during interrogation; insults and verbal insults during transfer in Tier 1A; sleep deprivation; walking in the corridors handcuffed and naked, except for female underwear over the head; handcuffing either to the upper bed bars or doors of the cell for

SECRET//NOFORN//X1

1213

~~SECRET//NOFORN//X1~~

SUBJECT: (U) AR 15-6 Investigation of the Abu Ghraib Detention Facility and
205th MI Brigade

3-4 hours. Some detainees presented physical marks and psychological symptoms which were compatible with these allegations. Also noted were brutality upon capture, physical or psychological coercion during interrogation, prolonged isolation, and excessive and disproportionate use of force. (Reference Annex G, Appendix 1, TAB B)

(4) (U) The ICRC made a number of recommendations after the October 2003 visits, including: grant ICRC full and unimpeded access to all detainees; improve the security related to the accommodation structure; clarify and improve conditions of detention and treatment; distribute hygiene items, spare clothes, blankets, etc.; inform detainees of the reason for their detention; implement regular family visits for detainees; and increase recreational and educational activities. (Reference Annex G, Appendix 1, Tab B, ICRC Working Paper, dated 6 November 2003).

(5) (U) LTC Phillabaum, regarding the 9 – 12 October 2003 visit, stated he was told of naked detainees by the ICRC and immediately contacted LTC Jordan. The two went to see the situation first hand. LTC Phillabaum claimed that LTC Jordan acknowledged that it was common practice for some of the detainees to be kept naked in their cells. In November 2003, after having received the written ICRC report, CJTF-7 sent an Australian Judge Advocate officer, MAJ George O’Kane, to Abu Ghraib to meet with LTC Jordan and other officers to craft a response to the ICRC memo. (Reference Annex B, Appendices 1 and 2, PHILLABAUM)

(6) (U) Stemming from those October 2003 visits, the ICRC also made the following request of the Coalition Forces: respect at all times the human dignity, physical integrity, and cultural sensitivity of detainees; set up a system of notification of arrest to the families of detainees; prevent all forms of ill-treatment; respect and protect the dignity of detainees; allow sufficient time for outside activity and exercise; define and apply regulations compatible with international Humanitarian Law; thoroughly investigate violation of international Humanitarian Law; ensure that capturing forces and interment facility personnel are trained to function in a proper manner without resorting to ill-treatment of detainees. (Reference ANNEX G, Appendix 1, Tab A, ICRC Report February 2004)

(7) (U) COL Warren, the CJTF-7 SJA, stated that neither he nor anyone else from CJTF-7 Headquarters was present at Abu Ghraib during the ICRC visit in October 2003. Throughout 2003, all ICRC reports were addressed to the commander or subordinate commanders of the 800 MP BDE. The OSJA received a copy of the reports. Letters on specific topics addressed to LTG Sanchez were given to COL Warren and he would prepare the response for LTG Sanchez. MAJ O’Kane prepared an analysis of the report on 25 November 2003 and the draft was sent to CJTF-7 C2 and the 800 MP BDE for review. On 4 December 2003, a meeting was held at Abu Ghraib, attended by MP, MI, and legal personnel, in order to discuss the report. In mid-December, the draft response was sent by OSJA to the 800 MP BDE for review and coordination. BG

~~SECRET//NOFORN//X1~~

SECRET//NOFORN//X1

SUBJECT: (U) AR 15-6 Investigation of the Abu Ghraib Detention Facility and
205th MI Brigade

Karpinski signed the response, dated 24 December 2003. (Reference Annex G, Appendix 3, KARPINSKI Letter)

(8) (U) During the 4-8 January 2004 visit, the ICRC expressed special concern over being informed by COL Pappas and COL Warren that they were invoking Article 143 of Geneva Convention IV, thereby denying the ICRC access to eight of the detainees in the interrogation section. Of particular interest was the status of detainee DETAINEE-14, a Syrian national and self-proclaimed Jihadist, who was in Iraq to kill coalition troops. DETAINEE-14 was detained in a totally darkened cell measuring about 2 meters long and less than a meter across, devoid of any window, latrine or water tap, or bedding. On the door the ICRC delegates noticed the inscription "the Gollum," and a picture of the said character from the film trilogy "Lord of the Rings." During the 14-18 March 2004 visit, the ICRC was once again denied access to nine detainees, including DETAINEE-14. They noted that DETAINEE-14 was no longer in the same cell as he was previously, but was still in one of the more "difficult" cells. (Reference Annex G, Appendix 1, ICRC Working Paper, dated 6 November 2003; Appendix 2, ICRC Letter dated February 2004; Appendix 2, Tab B, ICRC Letter dated 25 March 2004)

(9) (U) Article 143, Fourth Geneva Convention, reads in part "Such visits may be prohibited except for reasons of imperative military necessity, and then only for an exceptional and temporary measure." COL Warren and COL Pappas both acknowledge denying access to specified detainees by the ICRC on each of two occasions (in January and March 2004), invoking the above cited provision. The ICRC, in their memorandum of 25 March 2004, acknowledged the right of COL Warren and COL Pappas to invoke the "imperative military necessity clause." It questioned the "exceptional and temporary" nature of the denial of access to DETAINEE-14 on both occasions, however, given that DETAINEE-14 (by the time of the second visit) had been under interrogation for some four months. This was the same DETAINEE-14 that was viewed a "special project" and who was abused by the use of dogs. (See paragraph 5.f.) (Reference Annex B, Appendix 1, PAPPAS, WARREN)

(10) (U) COL Pappas acknowledges in his statement that the ICRC visited Abu Ghraib twice (January and March 2004). He received a copy of the results and noted there were allegations of maltreatment and detainees wearing women's underwear on their heads. He did not believe it. He recalled he might have related to the staff that "this stuff couldn't have been happening." He added that when the ICRC came by the second time (March 2004), he invoked Article 143, preventing the eight detainees in Tier 1A from talking to the ICRC while undergoing active interrogation. COL Pappas states: "COL Warren informed me that I had the authority to do this." (Reference Annex B, Appendices 1 and 2, PAPPAS)

(11) (U) COL Warren also stated that when he saw the ICRC report on naked detainees and detainees wearing women's underwear, he couldn't believe it. He saw the report when he

SECRET//NOFORN//X1

SECRET//NOFORN//X1

SUBJECT: (U) AR 15-6 Investigation of the Abu Ghraib Detention Facility and
205th MI Brigade

returned to CJTF-7 from leave on 30 November 2003. His office probably had received the report on 16 November 2003. He regrets not having taken the report earlier to LTG Sanchez or MG Wojdakowski. While this would not have prevented the abuse they subsequently discovered (because it had taken place in November 2003), it may have resulted in CID beginning an investigation a month earlier than they did. During the ICRC's next visit to Abu Ghraib, during the period 4-8 January 2004, COL Warren states they invoked Article 143 of the Fourth Geneva Conventions and did not allow the ICRC to have private interviews with eight detainees who were undergoing active interrogations. He did allow the ICRC delegate to see the detainees, observe the conditions of their detention, and obtain their names and Internee Serial Numbers." (Reference Annex B, Appendix 1, WARREN)

(12) (U) LTC Chew, Commander of the 115th MP Battalion (115 MP BN), has stated that although he attended the ICRC out-brief, after the 21-23 October 2003 visits, he never saw or heard of any detainees being stripped or held naked, nor did he ever see a written report from the ICRC. He stated that a doctor with the ICRC team provided information concerning a few detainees having psychological problems and stating that they should be evaluated. ICRC also related charges of handcuffing, nakedness, wearing of female underwear, and sleep deprivation. The ICRC also complained about lack of access to certain detainees, and he discussed the matter with LTC Jordan. He also discussed the allegations made by the ICRC with MAJ Potter, BG Karpinski, and MAJ Cavallero. BG Karpinski does not recall hearing about the report until early December 2003 when it was discussed at CJTF-7 Headquarters with COL Warren. (Reference Annex B, Appendix 1, CHEW, KARPINSKI)

(13) (U) LTC Jordan has stated that after the ICRC visited Abu Ghraib, COL Pappas and BG Karpinski received the final report, but that he did not see the report. When asked by COL Pappas if he had ever seen or heard any rumors of abuse, LTC Jordan told COL Pappas that he (LTC Jordan) had not. He was not aware of COL Pappas ever doing anything concerning the ICRC allegations (Reference Annex B, Appendix 1, JORDAN and Annex B, Appendix 2, JORDAN).

(14) (U) The only response to the ICRC was a letter signed by BG Karpinski, dated 24 December 2003. According to LTC Phillabaum and COL Warren (as quoted above) an Australian Judge Advocate officer, MAJ O'Kane, was the principal drafter of the letter. Attempts to interview MAJ O'Kane were unsuccessful. The Australian Government agreed to have MAJ O'Kane respond to written questions, but as of the time of this report, no response has been received. The section of the BG Karpinski letter pertaining to Abu Ghraib primarily addresses the denial of access to certain detainees by the ICRC. It tends to gloss over, close to the point of denying the inhumane treatment, humiliation, and abuse identified by the ICRC. The letter merely says: Improvement can be made for the provision of clothing, water, and personal hygiene items. (Reference Annex G, Appendix 3, KARPINSKI Letter)

SECRET//NOFORN//X1

SECRET//NOFORN//X1

SUBJECT: (U) AR 15-6 Investigation of the Abu Ghraib Detention Facility and
205th MI Brigade

5. Summary of Abuses at Abu Ghraib

a. (U) Several types of detainee abuse were identified in this investigation: physical and sexual abuse; improper use of military working dogs; humiliating and degrading treatments; and improper use of isolation.

(1) (U) Physical Abuse. Several Soldiers reported that they witnessed physical abuse of detainees. Some examples include slapping, kicking, twisting the hands of a detainee who was hand-cuffed to cause pain, throwing balls at restrained internees, placing gloved hand over the nose and mouth of an internee to restrict breathing, "poking" at an internee's injured leg, and forcing an internee to stand while handcuffed in such a way as to dislocate his shoulder. These actions are clearly in violation of applicable laws and regulations.

(2) (U) Use of Dogs. The use of military working dogs in a confinement facility can be effective and permissible under AR 190-12 as a means of controlling the internee population. When dogs are used to threaten and terrify detainees, there is a clear violation of applicable laws and regulations. One such impermissible practice was an alleged contest between the two Army dog handlers to see who could make the internees urinate or defecate in the presence of the dogs. An incident of clearly abusive use of the dogs occurred when a dog was allowed in the cell of two male juveniles and allowed to go "nuts." Both juveniles were screaming and crying with the youngest and smallest trying to hide behind the other juvenile. (Reference Annex B, Appendix 1, SOLDIER-17)

(3) (U) Humiliating and Degrading Treatments. Actions that are intended to degrade or humiliate a detainee are prohibited by GC IV, Army policy and the UCMJ. The following are examples of such behavior that occurred at Abu Ghraib, which violate applicable laws and regulations.

(4) (U) Nakedness. Numerous statements, as well as the ICRC report, discuss the seemingly common practice of keeping detainees in a state of undress. A number of statements indicate that clothing was taken away as a punishment for either not cooperating with interrogators or with MPs. In addition, male internees were naked in the presence of female Soldiers. Many of the Soldiers who witnessed the nakedness were told that this was an accepted practice. Under the circumstances, however, the nakedness was clearly degrading and humiliating.

(5) (U) Photographs. A multitude of photographs show detainees in various states of undress, often in degrading positions.

SECRET//NOFORN//X1

SECRET//NOFORN//X1

SUBJECT: (U) AR 15-6 Investigation of the Abu Ghraib Detention Facility and
205th MI Brigade

(6) (U) Simulated Sexual Positions. A number of Soldiers describe incidents where detainees were placed in simulated sexual positions with other internees. Many of these incidents were also photographed.

(7) (U) Improper Use of Isolation. There are some legitimate purposes for the segregation (or isolation) of detainees, specifically to prevent them from sharing interrogation tactics with other detainees or other sensitive information. Article 5 of Geneva Convention IV supports this position by stating that certain individuals can lose their rights of communication, but only when absolute military security requires. The use of isolation at Abu Ghraib was often done as punishment, either for a disciplinary infraction or for failure to cooperate with an interrogation. These are improper uses of isolation and depending on the circumstances amounted to violation of applicable laws and regulations. Isolation could properly be a sanction for a disciplinary infraction if applied through the proper process set out in AR 190-8 and the Geneva Conventions.

(8) (U) Failure to Safeguard Detainees. The Geneva Conventions and Army Regulations require that detainees be "protected against all acts of violence and threats thereof and against insults and public curiosity." Geneva Convention IV, Article 27 and AR 190-8, paragraph 5-1(a)(2). The duty to protect imposes an obligation on an individual who witnesses an abusive act to intervene and stop the abuse. Failure to do so may be a violation of applicable laws and regulations.

(9) (U) Failure to Report Detainee Abuse. The duty to report detainee abuse is closely tied to the duty to protect. The failure to report an abusive incident could result in additional abuse. Soldiers who witness these offenses have an obligation to report the violations under the provision of Article 92, UCMJ. Soldiers who are informed of such abuses also have a duty to report violations. Depending on their position and their assigned duties, the failure to report detainee abuse could support a charge of dereliction of duty, a violation of the UCMJ. Civilian contractors employed as interrogators and translators would also have a duty to report such offenses as they are also bound by the Geneva Conventions and are charged with protecting the internees.

(10) (U) Other traditional prison guard issues were far less clear. MPs are responsible for the clothing of detainees; however, MI interrogators started directing nakedness at Abu Ghraib as early as 16 September 2003 to humiliate and break down detainees. MPs would also sometimes discipline detainees by taking away clothing and putting detainees in cells naked. A severe shortage of clothing during the September, October, November 2003, time frame was frequently mentioned as the reason why people were naked. Removal of clothing and nakedness were being used to humiliate detainees at the same time there was a general level of confusion as to what was allowable in terms of MP disciplinary measures and MI interrogation rules, and what

SECRET//NOFORN//X1

SECRET//NOFORN//X1

SUBJECT: (U) AR 15-6 Investigation of the Abu Ghraib Detention Facility and
205th MI Brigade

clothing was available. This contributed to an environment that would appear to condone depravity and degradation rather than the humane treatment of detainees.

b. (U) The original intent by MI leadership (205 MI BDE) was for Tier 1A to be reserved for MI Holds only. In fact, CPT Wood states in an email dated 7 September 2003, during a visit from MG Miller and BG Karpinski, that BG Karpinski confirmed "we (MI) have all the iso (Isolation) cells in the wing we have been working. We only had 10 cells to begin with but that has grown to the entire wing." LTC Phillabaum also thought that MI had exclusive authority to house MI holds in Tier 1A. The fact is, however, that a number of those cells were often used by the MPs to house disciplinary problems. That fact is supported by the testimony of a large number of people who were there and further supported by the pictures and the detainee records. In fact, 11 of a total of 25 detainees identified by the CID as victims of abuse were not MI holds and were not being interrogated by MI. The MPs put the problem detainees (detainees who required separation from the general population for disciplinary reasons) in Tier 1A because there was no other place available to isolate them. Neither CPT Wood nor MAJ Williams appreciated the mixing because it did not allow for a pure MI environment, but the issue never made its way up to either LTC Phillabaum or to BG Karpinski.

c. (U) The "sleep adjustment" technique was used by MI as soon as the Tier 1A block opened. This was another source of confusion and misunderstanding between MPs and MI which contributed to an environment that allowed detainee abuse, as well as its perpetuation for as long as it continued. Sleep adjustment was brought with the 519 MI BN from Afghanistan. It is also a method used at GTMO. (See paragraph 3.b.(5)). At Abu Ghraib, however, the MPs were not trained, nor informed as to how they actually should do the sleep adjustment. The MPs were just told to keep a detainee awake for a time specified by the interrogator. The MPs used their own judgment as to how to keep them awake. Those techniques included taking the detainees out of their cells, stripping them and giving them cold showers. CPT Wood stated she did not know this was going on and thought the detainees were being kept awake by the MPs banging on the cell doors, yelling, and playing loud music. When one MI Soldier inquired about water being thrown on a naked detainee he was told that it was an MP discipline technique. Again, who was allowed to do what and how exactly they were to do it was totally unclear. Neither of the communities (MI and MP) knew what the other could and could not do. (Reference Annex B, Appendix 1, WOOD, JOYNER)

d. (U) This investigation found no evidence of confusion regarding actual physical abuse, such as hitting, kicking, slapping, punching, and foot stomping. Everyone we spoke to knew it was prohibited conduct except for one Soldier. (Reference Annex B, Appendix 1, SOLDIER-29). Physical discomfort from exposure to cold and heat or denial of food and water is not as clear-cut and can become physical or moral coercion at the extreme. Such abuse did occur at Abu Ghraib, such as detainees being left naked in their cells during severe cold weather without

SECRET//NOFORN//X1

SECRET//NOFORN//X1

SUBJECT: (U) AR 15-6 Investigation of the Abu Ghraib Detention Facility and
205th MI Brigade

blankets. In Tier 1A some of the excesses regarding physical discomfort were being done as directed by MI and some were being done by MPs for reasons not related to interrogation. (See paragraph 5.e.-h.)

e. (U) The physical and sexual abuses of detainees at Abu Ghraib are by far the most serious. The abuses spanned from direct physical assault, such as delivering head blows rendering detainees unconscious, to sexual posing and forced participation in group masturbation. At the extremes were the death of a detainee in OGA custody, an alleged rape committed by a US translator and observed by a female Soldier, and the alleged sexual assault of an unknown female. They were perpetrated or witnessed by individuals or small groups. Such abuse can not be directly tied to a systemic US approach to torture or approved treatment of detainees. The MPs being investigated claim their actions came at the direction of MI. Although self-serving, these claims do have some basis in fact. The climate created at Abu Ghraib provided the opportunity for such abuse to occur and to continue undiscovered by higher authority for a long period of time. What started as undressing and humiliation, stress and physical training (PT), carried over into sexual and physical assaults by a small group of morally corrupt and unsupervised Soldiers and civilians. Twenty-four (24) serious incidents of physical and sexual abuse occurred from 20 September through 13 December 2003. The incidents identified in this investigation include some of the same abuses identified in the MG Taguba investigation; however, this investigation adds several previously unreported events. A direct comparison cannot be made of the abuses cited in the MG Taguba report and this one.

(1) (U) **Incident #1.** On 20 September 2003, two MI Soldiers beat and kicked a passive, cuffed detainee, suspected of involvement in the 20 September 2003 mortar attack on Abu Ghraib that killed two Soldiers. Two Iraqis (male and female) were detained and brought to Abu Ghraib immediately following the attack. MI and the MP Internal Reaction Force (IRF) were notified of the apprehension and dispatched teams to the entry control point to receive the detainees. Upon arrival, the IRF observed two MI Soldiers striking and yelling at the male detainee whom they subsequently "threw" into the back of a High-Mobility Multipurpose Wheeled Vehicle (HMMWV). 1LT Sutton, 320th MP BN IRF intervened to stop the abuse and was told by the MI Soldiers "we are the professionals; we know what we are doing." They refused 1LT Sutton's lawful order to identify themselves. 1LT Sutton and his IRF team (SGT Spiker, SFC Plude) immediately reported this incident, providing sworn statements to MAJ Dinenna, 320 MP BN S3 and LTC Phillabaum, 320 MP BN Commander. 1SG McBride, A/205 MI BN interviewed and took statements from SGT Lawson, identified as striking the detainee, and each MI person present: SSG Hannifan, SSG Cole, SGT Claus, SGT Presnell. While the MP statements all describe abuse at the hands of an unidentified MI person (SGT Lawson), the MI statements all deny any abuse occurred. LTC Phillabaum subsequently reported the incident to the CID who determined the allegation lacked sufficient basis for prosecution. The detainee was interrogated and released that day (involvement in the mortar attack was unlikely); therefore, no

SECRET//NOFORN//X1

SECRET//NOFORN//X1

SUBJECT: (U) AR 15-6 Investigation of the Abu Ghraib Detention Facility and
205th MI Brigade

detainee is available to confirm either the MP or MI recollection of events. This incident was not further pursued based on limited data and the absence of additional investigative leads.

(Reference Annex B, Appendix 1, DINENNA, LAWSON, MCBRIDE, PHILLABAUM, PLUDE, SPIKER, SUTTON; Annex B, Appendix 2, DINENNA, PHILLABAUM, PLUDE; Annex B, Appendix 3, PLUDE, SPIKER)

(2) (U) **Incident #2.** On 7 October 2003, three MI personnel allegedly sexually assaulted female DETAINEE-29. CIVILIAN-06 (Titan) was the assigned interpreter, but there is no indication he was present or involved. DETAINEE-29 alleges as follows: First, the group took her out of her cell and escorted her down the cellblock to an empty cell. One unidentified Soldier stayed outside the cell (SOLDIER33, A/519 MI BN); while another held her hands behind her back, and the other forcibly kissed her (SOLDIER32, A/519 MI BN). She was escorted downstairs to another cell where she was shown a naked male detainee and told the same would happen to her if she did not cooperate. She was then taken back to her cell, forced to kneel and raise her arms while one of the Soldiers (SOLDIER31, A/519 MI BN) removed her shirt. She began to cry, and her shirt was given back as the Soldier cursed at her and said they would be back each night. CID conducted an investigation and SOLDIER33, SOLDIER32, and SOLDIER31 invoked their rights and refused to provide any statements. DETAINEE-29 identified the three Soldiers as SOLDIER33, SOLDIER32, and SOLDIER31 as the Soldiers who kissed her and removed her shirt. Checks with the 519 MI BN confirmed no interrogations were scheduled for that evening. No record exists of MI ever conducting an authorized interrogation of her. The CID investigation was closed. SOLDIER33, SOLDIER32, and SOLDIER31 each received non-judicial punishment, Field Grade Article 15's, from the Commander, 205 MI BDE, for failing to get authorization to interrogate DETAINEE-29. Additionally, COL Pappas removed them from interrogation operations. (Reference Annex B, Appendix 1, PAPPAS; Annex B, Appendix 2, PAPPAS; Annex B, Appendix 3, DETAINEE-29).

(3) **Incident #3.** On 25 October 2003 detainees DETAINEE-31, DETAINEE-30, and DETAINEE-27 were stripped of their clothing, handcuffed together nude, placed on the ground, and forced to lie on each other and simulate sex while photographs were taken. Six photographs depict this abuse. Results of the CID investigation indicate on several occasions over several days, detainees were assaulted, abused and forced to strip off their clothing and perform indecent acts on each other. DETAINEE-27 provided a sworn statement outlining these abuses. Those present and/or participating in the abuse were CPL Graner, 372 MP CO, SSG Frederick, 372 MP CO, SPC England, 372 MP CO, SPC Harman, 372 MP CO, SOLDIER34, 372 MP CO, CIVILIAN-17, Titan Corp., SOLDIER-24, B/325 MI BN, SOLDIER19, 325 MI BN, and SOLDIER10, 325 MI BN. SOLDIER-24 claimed he accompanied SOLDIER10 to the Hard Site the evening of 25 October 2003 to see what was being done to the three detainees suspected of raping a young male detainee. SOLDIER-10 appeared to have foreknowledge of the abuse, possibly from his friendship with SPC Harman, a 372 MP CO MP. SOLDIER-24 did not believe

SECRET//NOFORN//X1

SECRET//NOFORN//X1

SUBJECT: (U) AR 15-6 Investigation of the Abu Ghraib Detention Facility and
205th MI Brigade

the abuse was directed by MI and these individuals were not interrogation subjects. PFC England, however, claimed "MI Soldiers instructed them (MPs) to rough them up." When SOLDIER-24 arrived the detainees were naked, being yelled at by an MP through a megaphone. The detainees were forced to crawl on their stomachs and were handcuffed together. SOLDIER-24 observed SOLDIER-10 join in the abuse with CPL Graner and SSG Frederick. All three made the detainees act as though they were having sex. He observed SOLDIER-19 dump water on the detainees from a cup and throw a foam football at them. SOLDIER-24 described what he saw to SOLDIER-25, B/321 MI BN, who reported the incident to SGT Joyner, 372 MP CO. SGT Joyner advised SOLDIER-25 he would notify his NCOIC and later told SOLDIER-25 "he had taken care of it." SOLDIER-25 stated that a few days later both she and SOLDIER-24 told SOLDIER-22 of the incident. SOLDIER-22 subsequently failed to report what he was told. SOLDIER-25 did not report the abuse through MI channels because she felt it was an MP matter and would be handled by them.

(U) This is a clear incident of direct MI personnel involvement in detainee abuse; however, it does not appear to be based on MI orders. The three detainees were incarcerated for criminal acts and were not of intelligence interest. This incident was most likely orchestrated by MP personnel (CPL Graner, SSG Frederick, SOLDIER-34, SPC Harman, PFC England), with the MI personnel (SOLDIER-19, SOLDIER-10, and SOLDIER-24, CIVILIAN-17, and another unidentified interpreter) joining in and/or observing the abuse. (Reference Annex B, Appendix 1, JOYNER, SOLDIER-19, CIVILIAN-17, SOLDIER-25; Annex B, Appendix 3, SOLDIER-34, ENGLAND, HARMAN, DETAINEE-31, DETAINEE-30, DETAINEE-27; Annex I, Appendix 1, Photographs M36-41).

(4) (U) **Incident #4.** DETAINEE-08, arrived at Abu Ghraib on 27 October 2003 and was subsequently sent to the Hard Site. DETAINEE-08 claims when he was sent to the Hard Site, he was stripped of his clothing for six days. He was then given a blanket and remained with only the blanket for three more days. DETAINEE-08 stated the next evening he was transported by CPL Graner, 372 MP CO MP, to the shower room, which was commonly used for interrogations. When the interrogation ended, his female interrogator left, and DETAINEE-08 claims CPL Graner and another MP, who meets the description of SSG Fredrick, then threw pepper in DETAINEE-08's face and beat him for half an hour. DETAINEE-08 recalled being beaten with a chair until it broke, hit in the chest, kicked, and choked until he lost consciousness. On other occasions DETAINEE-08 recalled that CPL Graner would throw his food into the toilet and say "go take it and eat it." DETAINEE-08's claims of abuse do not involve his interrogator(s) and appear to have been committed by CPL Graner and SSG Frederick, both MPs. Reviewing the interrogation reports; however, suggests a correlation between this abuse and his interrogations. DETAINEE-08's interrogator for his first four interrogations was SOLDIER-29, a female, and almost certainly the interrogator he spoke of. Her Analyst was SOLDIER-10. In the first interrogation report they concluded he was lying and recommended a "fear up" approach if he continued to lie. Following his second interrogation it was recommended DETAINEE-08 be

SECRET//NOFORN//X1

SECRET//NOFORN//X1

SUBJECT: (U) AR 15-6 Investigation of the Abu Ghraib Detention Facility and
205th MI Brigade

moved to isolation (the Hard Site) as he continued "to be untruthful." Ten days later, a period roughly correlating with DETAINEE-08's claim of being without clothes and/or a blanket for nine days before his beating, was interrogated for a third time. The interrogation report references his placement in "the hole," a small lightless isolation closet, and the "Mutt and Jeff" interrogation technique being employed. Both techniques as they were used here were abusive and unauthorized. According to the report, the interrogators "let the MPs yell at him" and upon their return, "used a fear down," but "he was still holding back." The following day he was interrogated again and the report annotates "use a direct approach with a reminder of the unpleasantness that occurred the last time he lied." Comparing the interrogation reports with DETAINEE-08's recollections, it is likely the abuse he describes occurred between his third and fourth interrogations and that his interrogators were aware of the abuse, the "unpleasantness." SGT Adams stated that SOLDIER-29 and SSG Frederick had a close personal relationship and it is plausible she had CPL Graner and SSG Frederick "soften up this detainee" as they have claimed "MI" told them to do on several, unspecified, occasions (Reference Annex B, Appendix 1, ADAMS, SOLDIER-29; Annex B, Appendix 3, DETAINEE-08; Annex I, Appendix 4, DETAINEE-08).

(5) (U) **Incident #5.** In October 2003, DETAINEE-07, reported alleged multiple incidents of physical abuse while in Abu Ghraib. DETAINEE-07 was an MI Hold and considered of potentially high value. He was interrogated on 8, 21, and 29 October; 4 and 23 November and 5 December 2003. DETAINEE-07's claims of physical abuse (hitting) started on his first day of arrival. He was left naked in his cell for extended periods, cuffed in his cell in stressful positions ("High cuffed"), left with a bag over his head for extended periods, and denied bedding or blankets. DETAINEE-07 described being made to "bark like a dog, being forced to crawl on his stomach while MPs spit and urinated on him, and being struck causing unconsciousness." On another occasion DETAINEE-07 was tied to a window in his cell and forced to wear women's underwear on his head. On yet another occasion, DETAINEE-07 was forced to lie down while MPs jumped onto his back and legs. He was beaten with a broom and a chemical light was broken and poured over his body. DETAINEE-04 witnessed the abuse with the chem-light. During this abuse a police stick was used to sodomize DETAINEE-07 and two female MPs were hitting him, throwing a ball at his penis, and taking photographs. This investigation surfaced no photographic evidence of the chemical light abuse or sodomy. DETAINEE-07 also alleged that CIVILIAN-17, MP Interpreter, Titan Corp., hit DETAINEE-07 once, cutting his ear to an extent that required stitches. He told SOLDIER-25, analyst, B/321 MI BN, about this hitting incident during an interrogation. SOLDIER-25 asked the MPs what had happened to the detainee's ear and was told he had fallen in his cell. SOLDIER-25 did not report the detainee's abuse. SOLDIER-25 claimed the detainee's allegation was made in the presence of CIVILIAN-21, Analyst/Interrogator, CACI, which CIVILIAN-21 denied hearing this report. Two photos taken at 2200 hours, 1 November 2003 depict a detainee with stitches in his ear; however, we could not confirm the photo was DETAINEE-07. Based on the details provided by the detainee and the

SECRET//NOFORN//X1

SECRET//NOFORN//X1

SUBJECT: (U) AR 15-6 Investigation of the Abu Ghraib Detention Facility and
205th MI Brigade

close correlation to other known MP abuses, it is highly probable DETAINEE-07's allegations are true. SOLDIER-25 failed to report the detainee's allegation of abuse. His statements and available photographs do not point to direct MI involvement. However, MI interest in this detainee, his placement in Tier 1A of the Hard Site, and initiation of the abuse once he arrived there, combine to create a circumstantial connection to MI (knowledge of or implicit tasking of the MPs to "set conditions") which are difficult to ignore. MI should have been aware of what was being done to this detainee based on the frequency of interrogations and high interest in his intelligence value. (Reference Annex B, Appendix 1, SOLDIER-25, CIVILIAN-21; Annex B, Appendix 3, DETAINEE-04, DETAINEE-07; Annex I, Appendix 1, Photographs M54-55).

(6) (U) **Incident #6.** DETAINEE-10 and DETAINEE-12 claimed that they and "four Iraqi Generals, were abused upon their arrival at the Hard Site. DETAINEE-10 was documented in MP records as receiving a 1.5 inch laceration on his chin, the result of his resisting an MP transfer. His injuries are likely those captured in several photographs of an unidentified detainee with a lacerated chin and bloody clothing which were taken on 14 November, a date coinciding with his transfer. DETAINEE-12 claimed he was slammed to the ground, punched, and forced to crawl naked to his cell with a sandbag over his head. These two detainees as well as the other four (DETAINEE-20, DETAINEE-19, DETAINEE-22, DETAINEE-21) were all high value Iraqi General Officers or senior members of the Iraqi Intelligence Service. MP logs from the Hard Site indicate they attempted to incite a riot in Camp Vigilant while being transferred to the Hard Site. There is no documentation of what occurred at Camp Vigilant or of detainees receiving injuries. When DETAINEE-10 was in-processed into the Hard Site, he was resisting and was pushed against the wall. At that point the MPs noticed blood coming from under his hood and they discovered the laceration on his chin. A medical corpsman was immediately called to suture the detainee's chin. These events are all documented, indicating the injury occurred before the detainee's arrival at the Hard Site and that he received prompt medical attention. When, where, and by whom this detainee suffered his injuries could not be determined nor could an evaluation be made of whether it constituted "reasonable force" in conjunction with a riot. Our interest in this incident stems from MP logs concerning DETAINEE-10 indicating MI provided direction about his treatment. CPL Graner wrote an entry indicating he was told by SFC Joyner, who was in turn told by LTC Jordan, to "Strip them out and PT them." Whether "strip out" meant to remove clothing or to isolate we couldn't determine. Whether "PT them" meant physical stress or abuse can't be determined. The vagueness of this order could, however, have led to any subsequent abuse. The alleged abuse, injury, and harsh treatment correlating with the detainees' transfer to MI hold also suggest MI could have provided direction or MP could have been given the perception they should abuse or "soften up detainees," however, there is no clear proof. (Reference Annex B, Appendix 1, JORDAN, JOYNER; Annex C).

(7) (U) **Incident #7.** On 4 November 2003, a CIA detainee, DETAINEE-28 died in custody in Tier 1B. Allegedly, a Navy SEAL Team had captured him during a joint TF-121/CIA

SECRET//NOFORN//X1

SECRET//NOFORN//X1

SUBJECT: (U) AR 15-6 Investigation of the Abu Ghraib Detention Facility and
205th MI Brigade

mission. DETAINEE-28 was suspected of having been involved in an attack against the ICRC and had numerous weapons with him at the time of his apprehension. He was reportedly resisting arrest, and a SEAL Team member butt-stroked him on the side of the head to suppress the threat he posed. CIA representatives brought DETAINEE-28 into Abu Ghraib sometime around 0430 to 0530 without notifying JIDC Operations, in accordance with a supposed verbal agreement with the CIA. While all the details of DETAINEE-28's death are still not known (CIA, DOJ, and CID have yet to complete and release the results of their investigations), SPC Stevanus, an MP on duty at the Hard Site at the time DETAINEE-28 was brought in, stated that two CIA representatives came in with DETAINEE-28 and he was placed in a shower room (in Tier 1B). About 30 to 45 minutes later, SPC Stevanus was summoned to the shower stall, and when he arrived, DETAINEE-28 appeared to be dead. SPC Stevanus removed the sandbag which was over DETAINEE-28's head and checked for the detainee's pulse. He found none. He un-cuffed DETAINEE-28 called for medical assistance, and notified his chain of command. LTC Jordan stated that he was informed of the death shortly thereafter, at approximately 0715 hours. LTC Jordan arrived at the Hard Site and talked to CIVILIAN03, an Iraqi prison medical doctor, who informed him DETAINEE-28 was dead. LTC Jordan stated that DETAINEE-28 was in the Tier 1B shower stall, face down, handcuffed with his hands behind his back. LTC Jordan's version of the handcuffs conflicts with SPC Stevanus' account that he un-cuffed DETAINEE-28. This incident remains under CID and CIA investigation.

(U) A CIA representative identified only as "OTHER AGENCY EMPLOYEE-01" was present, along with several MPs and US medical staff. LTC Jordan recalled that it was "OTHER AGENCY EMPLOYEE-01" who un-cuffed DETAINEE-28 and the body was turned over. LTC Jordan stated that he did not see any blood anywhere, except for a small spot where DETAINEE-28's head was touching the floor. LTC Jordan notified COL Pappas (205 MI BDE Commander), and "OTHER AGENCY EMPLOYEE-01" said he would notify "OTHER AGENCY EMPLOYEE-02," his CIA supervisor. Once "OTHER AGENCY EMPLOYEE-02" arrived, he stated he would call Washington, and also requested that DETAINEE-28's body be held in the Hard Site until the following day. The body was placed in a body bag, packed in ice, and stored in the shower area. CID was notified and the body was removed from Abu Ghraib the next day on a litter to make it appear as if DETAINEE-28 was only ill, thereby not drawing the attention of the Iraqi guards and detainees. The body was transported to the morgue at BIAP for an autopsy, which concluded that DETAINEE-28 died of a blood clot in the head, a likely result of injuries he sustained while resisting apprehension. There is no indication or accusations that MI personnel were involved in this incident except for the removal of the body. (Reference Annex B, Appendix 1, JORDAN, PAPPAS, PHILLABAUM, SNIDER, STEVANUS, THOMPSON; Annex I, Appendix 1, Photographs C5-21, D5-11, M65-69).

(8) (U) **Incident #8.** On 20 October 2003, DETAINEE-03, was allegedly stripped and physically abused for sharpening a toothbrush to make a shank (knife-like weapon).

SECRET//NOFORN//X1

SECRET//NOFORN//X1

SUBJECT: (U) AR 15-6 Investigation of the Abu Ghraib Detention Facility and
205th MI Brigade

DETAINEE-03 claimed the toothbrush was not his. An MP log book entry by SSG Frederick, 372 MPs, directed DETAINEE-03 to be stripped in his cell for six days. DETAINEE-03 claimed he was told his clothing and mattress would be taken away as punishment. The next day he claims he was cuffed to his cell door for several hours. He claims he was taken to a closed room where he had cold water poured on him and his face was forced into someone's urine. DETAINEE-03 claimed he was then beaten with a broom and spat upon, and a female Soldier stood on his legs and pressed a broom against his anus. He described getting his clothes during the day from SGT Joyner and having them taken away each night by CPL Graner for the next three days. DETAINEE-03 was an MI Hold but was not interrogated between 16 September and 2 November 2003. It is plausible his interrogators would be unaware of the alleged abuse and DETAINEE-03 made no claim he informed them (Reference Annex B, Appendix 3, DETAINEE-03).

(9) (U) **Incident #9.** Three photographs taken on 25 October 2003 depicted PFC England, 372 MP CO, holding a leash which was wrapped around an unidentified detainee's neck. Present in the photograph is SPC Ambuhl who was standing to the side watching. PFC England claimed in her initial statement to CID that CPL Graner had placed the tie-down strap around the detainee's neck and then asked her to pose for the photograph. There is no indication of MI involvement or knowledge of this incident (Reference Annex E, CID Report and Reference Annex I, Appendix 1, Photographs M33-35).

(10) (U) **Incident #10.** Six Photographs of DETAINEE-15, depict him standing on a box with simulated electrical wires attached to his fingers and a hood over his head. These photographs were taken between 2145 and 2315 on 4 November 2003. DETAINEE-15 described a female making him stand on the box, telling him if he fell off he would be electrocuted, and a "tall black man" as putting the wires on his fingers and penis. From the CID investigation into abuse at Abu Ghraib it was determined SGT J. Davis, SPC Harman, CPL Graner, and SSG Frederick, 372 MP CO, were present during this abuse. DETAINEE-15 was not an MI Hold and it is unlikely MI had knowledge of this abuse (Reference Annex B, Appendix 3, DETAINEE-15; Annex I, Appendix 1, Photographs C1-2, D19-21, M64).

(11) (U) **Incident #11.** Twenty-nine photos taken between 2315 and 0024, on 7 and 8 November 2003 depict seven detainees (DETAINEE-17, DETAINEE-16, DETAINEE-24, DETAINEE-23, DETAINEE-26, DETAINEE-01, DETAINEE-18) who were physically abused, placed in a pile and forced to masturbate. Present in some of these photographs are CPL Graner and SPC Harman. The CID investigation into these abuses identified SSG Frederick, CPL Graner, SGT J. Davis, SPC Ambuhl, SPC Harman, SPC Sivits, and PFC England; all MPs, as involved in the abuses which occurred. There is no evidence to support MI personnel involvement in this incident. CID statements from PFC England, SGT J. Davis, SPC Sivits, SPC Wisdom, SPC Harman, DETAINEE-17, DETAINEE-01, and DETAINEE-16 detail that the

SECRET//NOFORN//X1

SECRET//NOFORN//X1

SUBJECT: (U) AR 15-6 Investigation of the Abu Ghraib Detention Facility and
205th MI Brigade

detainees were stripped, pushed into a pile, and jumped on by SGT J. Davis, CPL Graner, and SSG Frederick. They were photographed at different times by SPC Harman, SPC Sivits, and SSG Frederick. The detainees were subsequently posed sexually, forced to masturbate, and "ridden like animals." CPL Graner knocked at least one detainee unconscious and SSG Frederick punched one so hard in the chest that he couldn't breathe and a medic was summoned. SSG Frederick initiated the masturbation and forced the detainees to hit each other. PFC England stated she observed SSG Frederick strike a detainee in the chest during these abuses. The detainee had difficulty breathing and a medic, SOLDIER-01, was summoned. SOLDIER-01 treated the detainee and while in the Hard Site observed the "human pyramid" of naked detainees with bags over their heads. SOLDIER-01 failed to report this abuse. These detainees were not MI Holds and MI involvement in this abuse has not been alleged nor is it likely. SOLDIER-29 reported seeing a screen saver for a computer in the Hard Site that depicted several naked detainees stacked in a "pyramid." She also once observed, unrelated to this incident, CPL Graner slap a detainee. She stated that she didn't report the picture of naked detainees to MI because she did not see it again and also did not report the slap because she didn't consider it abuse (Reference Annex B, Appendix 1, SOLDIER-29; Annex B, Appendix 3, DETAINEE-01, DETAINEE-17, DETAINEE-16, ENGLAND, DAVIS, HARMAN, SIVITS, WISDOM; Annex B, Appendix 3, TAB A, SOLDIER-01, and Annex I, Appendix 1, Photographs C24-42, D22-25, M73-77, M87).

(12) (U) **Incident #12.** A photograph taken circa 27 December 2003, depicts a naked DETAINEE-14, apparently shot with a shotgun in his buttocks. This photograph could not be tied to a specific incident, detainee, or allegation and MI involvement is indeterminate (Reference Annex I, Appendix 1, Photographs D37-38, H2, M111).

(13) (U) **Incident #13.** Three photographs taken on 29 November 2003, depict an unidentified detainee dressed only in his underwear, standing with each foot on a separate box, and bent over at the waist. This photograph could not be tied to a specific incident, detainee, or allegation and MI involvement is indeterminate. (Reference Annex I, Appendix 1, Photographs D37-38, M111)

(14) (U) **Incident #14.** An 18 November 2003 photograph depicts a detainee dressed in a shirt or blanket lying on the floor with a banana inserted into his anus. This as well as several others show the same detainee covered in feces, with his hands encased in sandbags, or tied in foam and between two stretchers. These are all identified as DETAINEE-25 and were determined by CID investigation to be self-inflicted incidents. Even so, these incidents constitute abuse; a detainee with a known mental condition should not have been provided the banana or photographed. The detainee has a severe mental problem and the restraints depicted in these photographs were allegedly used to prevent the detainee from sodomizing himself and assaulting himself and others with his bodily fluids. He was known for inserting various objects

SECRET//NOFORN//X1

SECRET//NOFORN//X1

SUBJECT: (U) AR 15-6 Investigation of the Abu Ghraib Detention Facility and
205th MI Brigade

into his rectum and for consuming and throwing his urine and feces. MI had no association with this detainee (Reference Annex C; Annex E; Annex I, Appendix 1, Photographs, C22-23, D28-36, D39, M97-99, M105-110, M131-133).

(15) (U) **Incident #15.** On 26 or 27 November 2003, SOLDIER-15, 66 MI GP, observed CIVILIAN-11, a CACI contractor, interrogating an Iraqi policeman. During the interrogation, SSG Frederick, 372 MP CO, alternated between coming into the cell and standing next to the detainee and standing outside the cell. CIVILIAN-11 would ask the policeman a question stating that if he did not answer, he would bring SSG Frederick back into the cell. At one point, SSG Frederick put his hand over the policeman's nose, not allowing him to breathe for a few seconds. At another point SSG Frederick used a collapsible nightstick to push and possibly twist the policeman's arm, causing pain. When SSG Frederick walked out of the cell, he told SOLDIER-15 he knew ways to do this without leaving marks. SOLDIER-15 did not report the incident. The interpreter utilized for this interrogation was CIVILIAN-16. (Reference Annex B, Appendix 1, SOLDIER-15)

(16) (U) **Incident #16.** On an unknown date, SGT Hernandez, an analyst, observed CIVILIAN-05, a CACI contractor, grab a detainee from the back of a High-Mobility, Multipurpose, Wheeled Vehicle (HMMWV) and drop him on the ground. CIVILIAN-05 then dragged the detainee into an interrogation booth. The detainee was handcuffed the entire time. When the detainee tried to get up to his knees, CIVILIAN-05 would force him to fall. SGT Hernandez reported the incident to CID but did not report it in MI channels. (Reference Annex B, Appendix 1, HERNANDEZ)

(17) (U) **Incident #17.** A 30 November 2003, MP Log entry described an unidentified detainee found in a cell covered in blood. This detainee had assaulted CPL Graner, 372 MP CO, while they moved him to an isolation cell in Tier 1A. CPL Graner and CPL Kamauf, subdued the detainee, placed restraints on him and put him in an isolation cell. At approximately 0320 hours, 30 November 2003, after hearing banging on the isolation cell door, the cell was checked and the detainee was found in the cell standing by the door covered in blood. This detainee was not an MI Hold and there is no record of MI association with this incident or detainee. (Reference Annex I, Appendix 1, Photographs M115-129, M134).

(18) (U) **Incident #18.** On approximately 12 or 13 December 2003, DETAINEE-06 claimed numerous abuse incidents against US Soldiers. DETAINEE-06 was a Syrian foreign fighter and self-proclaimed Jihadist who came to Iraq to kill Coalition troops. DETAINEE-06 stated the Soldiers supposedly retaliated against him when he returned to the Hard Site after being released from the hospital following a shooting incident in which he attempted to kill US Soldiers. DETAINEE-06 had a pistol smuggled into him by an Iraqi Policeman and used that pistol to try to kill US personnel working in the Hard Site on 24 November 2003. An MP

SECRET//NOFORN//X1

SECRET//NOFORN//X1SUBJECT: (U) AR 15-6 Investigation of the Abu Ghraib Detention Facility and
205th MI Brigade

returned fire and wounded DETAINEE-06. Once DETAINEE-06 ran out of ammunition, he surrendered and was transported to the hospital. DETAINEE-06 claimed CIVILIAN-21 visited him in the hospital and threatened him with terrible torture upon his return. DETAINEE-06 claimed that upon his return to the Hard Site, he was subjected to various threats and abuses which included Soldiers threatening to torture and kill him, being forced to eat pork and having liquor put in his mouth, having a "very hot" substance put in his nose and on his forehead, having the guards hit his "broken" leg several times with a solid plastic stick, being forced to "curse" his religion, being urinated on, being hung by handcuffs from the cell door for hours, being "smacked" on the back of the head, and "allowing dogs to try to bite" him. This claim was substantiated by a medic, SOLDIER-20, who was called to treat a detainee (DETAINEE-06) who had been complaining of pain. When SOLDIER-20 arrived DETAINEE-06 was cuffed to the upper bunk so that he could not sit down and CPL Graner was poking at his wounded legs with an asp with DETAINEE-06 crying out in pain. SOLDIER-20 provided pain medication and departed. He returned the following day to find DETAINEE-06 again cuffed to the upper bunk and a few days later returned to find him cuffed to the cell door with a dislocated shoulder. SOLDIER-20 failed to either stop or report this abuse. DETAINEE-06 also claimed that prior to the shooting incident, which he described as when "I got shot with several bullets" without mentioning that he ever fired a shot, he was threatened "every one or two hours... with torture and punishment", was subjected to sleep deprivation by standing up "for hours and hours", and had a "black man" tell him he would rape DETAINEE-06 on two occasions. Although DETAINEE-06 stated that CPL Graner led "a number of Soldiers" into his cell, he also stated that he had never seen CPL Graner beat a prisoner. These claims are from a detainee who attempted to kill US service members. While it is likely some Soldiers treated DETAINEE-06 harshly upon his return to the Hard Site, DETAINEE-06's accusations are potentially the exaggerations of a man who hated Americans. (Reference Annex B, Appendix 3, DETAINEE-06, SOLDIER-20).

(19) (U) **Incident #19.** SGT Adams, 470 MI GP, stated that sometime between 4 and 13 December 2003, several weeks after the shooting of "a detainee who had a pistol" (DETAINEE-06), she heard he was back from the hospital, and she went to check on him because he was one of the MI Holds she interrogated. She found DETAINEE-06 without clothes or blanket, his wounds were bleeding and he had a catheter on without a bag. The MPs told her they had no clothes for the detainee. SGT Adams ordered the MPs to get the detainee some clothes and went to the medical site to get the doctor on duty. The doctor (Colonel) asked what SGT Adams wanted and was asked if he was aware the detainee still had a catheter on. The Colonel said he was, the Combat Army Surgical Hospital (CASH) had made a mistake, and he couldn't remove it because the CASH was responsible for it. SGT Adams told him this was unacceptable, he again refused to remove it and stated the detainee was due to go back to the CASH the following day. SGT Adams asked if he had ever heard of the Geneva Conventions, and the Colonel responded "fine Sergeant, you do what you have to do, I am going back to bed."

SECRET//NOFORN//X1

SECRET//NOFORN//X1

SUBJECT: (U) AR 15-6 Investigation of the Abu Ghraib Detention Facility and
205th MI Brigade

(U) It is apparent from this incident that DETAINEE06 did not receive proper medical treatment, clothing or bedding. The "Colonel" has not been identified in this investigation, but efforts continue. LTC Akerson was chief of the medical team for "security holds" at Abu Ghraib from early October to late December 2003. He treated DETAINEE06 following his shooting and upon his return from the hospital. He did not recall such an incident or DETAINEE06 having a catheter. It is possible SGT Adams was taken to a different doctor that evening. She asked and was told the doctor was a Colonel, not a Lieutenant Colonel and is confident she can identify the Colonel from a photograph. LTC Akerson characterized the medical records as being exceptional at Abu Ghraib, however, the records found by this investigation were poor and in most cases non-existent. (Reference Annex B, Appendix 1, ADAMS, AKERSON; Annex B, Appendix 3, DETAINEE-06).

(20) (U) **Incident #20.** During the fall of 2003, a detainee stated that another detainee, named DETAINEE-09, was stripped, forced to stand on two boxes, had water poured on him and had his genitals hit with a glove. Additionally, the detainee was handcuffed to his cell door for a half day without food or water. The detainee making the statement did not recall the exact date or participants. Later, "Assad" was identified as DETAINEE-09, who stated that on 5 November 2003 he was stripped naked, beaten, and forced to crawl on the floor. He was forced to stand on a box and was hit in his genitals. The participants in this abuse could not be determined. MI involvement is indeterminate. (Reference Annex B, Appendix 3, DETAINEE-09; Annex I, Appendix 1, Photographs D37-38, M111)

(21) (U) **Incident #21.** Circa October 2003, CIVILIAN-17, an interpreter of the Titan Corporation, observed the following incident: CPL Graner, 372 MP CO, pushed a detainee, identified as one of the "three stooges" or "three wise men", into a wall, lacerating the detainee's chin. CIVILIAN-17 specifically stated the detainee was pushed into a wall and "busted his chin." A medic, SGT Wallin, stated he was summoned to stitch the detainee and treated a 2.5 inch laceration on the detainee's chin requiring 13 stitches. SGT Wallin did not know how the detainee was injured. Later that evening, CPL Graner took photos of the detainee. CPL Graner was identified in another incident where he stitched an injured detainee in the presence of medics. There is no indication of MI involvement, knowledge, or direction of this abuse. (Reference Annex B, Appendix 1, CIVILIAN-17; Annex B, Appendix 3, CIVILIAN-17, WALLIN, DETAINEE-02; Annex I, Appendix 1, Photographs M88-96).

(22) (U) **Incident #22.** On an unknown date, an interpreter named "CIVILIAN-01" allegedly raped a 15-18 year old male detainee according to DETAINEE-05. DETAINEE-05 heard screaming and climbed to the top of his cell door to see over a sheet covering the door of the cell where the abuse was occurring. DETAINEE-05 observed CIVILIAN-01, who was wearing a military uniform, raping the detainee. A female Soldier was taking pictures.

SECRET//NOFORN//X1

~~SECRET//NOFORN//X1~~

SUBJECT: (U) AR 15-6 Investigation of the Abu Ghraib Detention Facility and
205th MI Brigade

DETAINEE-05 described CIVILIAN-01 as possibly Egyptian, "not skinny or short," and effeminate. The date and participants of this alleged rape could not be confirmed. No other reporting supports DETAINEE-05's allegation, nor have photographs of the rape surfaced. A review of all available records could not identify a translator by the name of CIVILIAN-01. DETAINEE05's description of the interpreter partially matches CIVILIAN-17, Interpreter, Titan Corp. CIVILIAN-17 is a large man, believed by several witnesses to be homosexual, and of Egyptian extraction. CIVILIAN-17 functioned as an interpreter for a Tactical HUMINT Team at Abu Ghraib, but routinely provided translation for both MI and MP. CID has an open investigation into this allegation. (Reference Annex B, Appendix 3, DETAINEE-05)

(23) (U) **Incident #23.** On 24 November 2003, a US Army officer, CPT Brinson, MP, allegedly beat and kicked a detainee. This is one of three identified abuses associated with the 24 November shooting. A detainee obtained a pistol from Iraqi police guards, shot an MP and was subsequently shot and wounded. During a subsequent search of the Hard Site and interrogation of detainees, SGT Spiker, 229 MP CO, a member of the Abu Ghraib Internal Reaction Force (IRF), observed an Army Captain dragging an unidentified detainee in a choke hold, throwing him against a wall, and kicking him in the mid-section. SPC Polak, 229 MP CO, IRF was also present in the Hard Site and observed the same abuse involving two Soldiers and a detainee. The detainee was lying on his stomach with his hands cuffed behind his back and a bag over his head. One Soldier stood next to him with the barrel of a rifle pressed against the detainee's head. The other Soldier was kneeling next to the detainee punching him in the back with a closed fist. The Soldier then stood up and kicked the detainee several times. The Soldier inflicting the beating was described as a white male with close cropped blond hair. SPC Polak saw this Soldier a few days later in full uniform, identifying him as a Captain, but could not see his name. Both SPC Polak and SGT Spiker reported this abuse to their supervisors, SFC Plude and 1LT Sutton, 372 MP CO. Photos of company grade officers at Abu Ghraib during this time were obtained and shown to SPC Polak and SGT Spiker, who positively identified the "Captain" as CPT Brinson. This incident was investigated by CID and the assault was determined to be unfounded; a staged event to protect the fact the detainee was a cooperative MP Source. (Reference Annex B, Appendix 1, PLUDE, POLAK, SPIKER, SUTTON; Annex B, Appendix 3, PLUDE, SUTTON; Annex E, Appendix 5, CID Report of Investigation 0005-04-CID149-83131)

(24) (U) **Incident #24.** A photograph created circa early December 2003 depicts an unidentified detainee being interrogated by CIVILIAN-11, CACI, Interrogator, and CIVILIAN-16, Titan, linguist. The detainee is squatting on a chair which is an unauthorized stress position. Having the detainee on a chair which is a potentially unsafe situation, and photographing the detainee are violations of the ICRP. (Reference Annex I, Appendix 2, Photograph "Stress Position").

~~SECRET//NOFORN//X1~~

SECRET//NOFORN//X4

SUBJECT: (U) AR 15-6 Investigation of the Abu Ghraib Detention Facility and
205th MI Brigade

f. (U) Incidents of Detainee Abuse Using Dogs. (U) Abusing detainees with dogs started almost immediately after the dogs arrived at Abu Ghraib on 20 November 2003. By that date, abuses of detainees was already occurring and the addition of dogs was just one more abuse device. Dog Teams were brought to Abu Ghraib as a result of recommendations from MG G. Miller's assessment team from JTF-GTMO. MG G. Miller recommended dogs as beneficial for detainee custody and control issues, especially in instances where there were large numbers of detainees and few guards to help reduce the risk of detainee demonstrations or acts of violence, as at Abu Ghraib. MG G. Miller never recommended, nor were dogs used for interrogations at GTMO. The dog teams were requested by COL Pappas, Commander, 205 MI BDE. COL Pappas never understood the intent as described by MG G. Miller. Interrogations at Abu Ghraib were also influenced by several documents that spoke of exploiting the Arab fear of dogs: a 24 January 2003 "CJTF 180 Interrogation Techniques," an 11 October 2002 JTF 170 "Counter-Resistance Strategies," and a 14 September 2003 CJTF-7 ICRP. Once the dogs arrived, there was controversy over who "owned" the dogs. It was ultimately decided that the dogs would be attached to the Internal Reaction Force (IRF). The use of dogs in interrogations to "fear up" detainees was generally unquestioned and stems in part from the interrogation techniques and counter-resistance policy distributed from CJTF 180, JTF 170 and CJTF-7. It is likely the confusion about using dogs partially stems from the initial request for dog teams by MI, not MPs, and their presence being associated with MG G. Miller's visit. Most military intelligence personnel believed that the use of dogs in interrogations was a "non-standard" technique which required approval, and most also believed that approval rested with COL Pappas. COL Pappas also believed, incorrectly, that he had such authority delegated to him from LTG Sanchez. COL Pappas's belief likely stemmed in part from the changing ICRP. The initial policy was published on 14 September 2003 and allowed the use of dogs subject to approval by LTG Sanchez. On 12 October 2003, these were amended to eliminate several techniques due to CENTCOM objections. After the 12 October 2003 amendment, the ICRP safeguards allowed that dogs present at interrogations were to be muzzled and under the control of a handler. COL Pappas did not recall how he got the authority to employ dogs; just that he had it. (Reference Annex B, Appendix 1, G. MILLER and PAPPAS, and Annex J, Appendix 3)

(U) SFC Plude stated the two Army dog teams never joined the Navy teams as part of the IRF and remained separate and under the direct control of MAJ Dinenna, S3, 320 MP BN. These teams were involved in all documented detainee abuse involving dogs; both MP and MI directed. The Navy dog teams were properly employed because of good training, excellent leadership, personal moral character, and professionalism exhibited by the Navy Dog Handlers, MAI Kimbro, MA1 Clark, and MA2 Pankratz, and IRF personnel. The Army teams apparently agreed to be used in abusive situations by both MPs and MI in contravention to their doctrine, training, and values. In an atmosphere of permissiveness and absence of oversight or leadership the Army dog teams became involved in several incidents of abuse over the following weeks

SECRET//NOFORN//X4

~~SECRET//NOFORN//X1~~

SUBJECT: (U) AR 15-6 Investigation of the Abu Ghraib Detention Facility and
205th MI Brigade

(Reference Annex B, Appendix 1, KIMBRO, PLUDE; Annex B, Appendix 2, PLUDE; Annex B, Appendix 3, PLUDE).

(1) (U) **Incident #25.** The first documented incident of abuse with dogs occurred on 24 November 2003, just four days after the dogs teams arrived. An Iraqi detainee was smuggled a pistol by an Iraqi Police Guard. While attempting to confiscate the weapon, an MP was shot and the detainee was subsequently shot and wounded. Following the shooting, LTC Jordan ordered several interrogators to the Hard Site to screen eleven Iraqi Police who were detained following the shooting. The situation at the Hard Site was described by many as "chaos," and no one really appeared to be in charge. The perception was that LTG Sanchez had removed all restrictions that night because of the situation; however, that was not true. No one is able to pin down how that perception was created. A Navy Dog Team entered the Hard Site and was instructed to search for additional weapons and explosives. The dogs searched the cells, no explosives were detected and the Navy Dog Team eventually completed their mission and left. Shortly thereafter, MA1 Kimbro, USN, was recalled when someone "needed" a dog. MA1 Kimbro went to the top floor of Tier 1B, rather than the MI Hold area of Tier 1A. As he and his dog approached a cell door, he heard yelling and screaming and his dog became agitated. Inside the cell were CIVILIAN-11 (CACI contract interrogator), a second unidentified male in civilian clothes who appeared to be an interrogator and CIVILIAN16 (female contract interpreter), all of whom were yelling at a detainee squatting in the back right corner. MA1 Kimbro's dog was barking a lot with all the yelling and commotion. The dog lunged and MA1 Kimbro struggled to regain control of it. At that point, one of the men said words to the effect "You see that dog there, if you don't tell me what I want to know, I'm gonna get that dog on you!" The three began to step out of the cell leaving the detainee inside and MA1 Kimbro backed-up to allow them to exit, but there was not much room on the tier. After they exited, the dog lunged and pulled MA1 Kimbro just inside the cell. He quickly regained control of his dog, and exited the cell. As CIVILIAN-11, CIVILIAN-16, and the other interrogator re-entered the cell, MA1 Kimbro's dog grabbed CIVILIAN-16's forearm in its mouth. It apparently did not bite through her clothes or skin and CIVILIAN-16 stated the dog did not bite her. Realizing he had not been called for an explosives search, MA1 Kimbro departed the area with his dog and as he got to the bottom of the tier stairs, he heard someone calling for the dog again, but he did not return. No record of this interrogation exists, as was the case for the interrogations of Iraqi Police in the hours and days following the shooting incident. The use of dogs in the manner directed by CIVILIAN-11 was clearly abusive and unauthorized (Reference Annex B, Appendix 1, SOLDIER-11, KIMBRO, PAPPAS, CIVILIAN-11; Annex B, Appendix 2, PAPPAS).

(U) Even with all the apparent confusion over roles, responsibilities and authorities, there were early indications that MP and MI personnel knew the use of dog teams in interrogations was abusive. Following this 24 November 2003, incident the three Navy dog teams concluded that some interrogators might attempt to misuse Navy Dogs to support their

~~SECRET//NOFORN//X1~~

SECRET//NOFORN//X1

SUBJECT: (U) AR 15-6 Investigation of the Abu Ghraib Detention Facility and
205th MI Brigade

interrogations. For all subsequent requests they inquired what the specific purpose of the dog was and when told "for interrogation" they explained that Navy dogs were not intended for interrogations and the request would not be fulfilled. Over the next few weeks, the Navy dog teams received about eight similar calls, none of which were fulfilled. In the later part of December 2003, COL Pappas summoned MA1 Kimbro and wanted to know what the Navy dogs' capabilities were. MA1 Kimbro explained Navy dog capabilities and provided the Navy Dog Use SOP. COL Pappas never asked if they could be used in interrogations and following that meeting the Navy Dog teams received no additional requests to support interrogations.

(2) (U) **Incident #26.** On or about 8 January 2004, SOLDIER-17 was conducting an interrogation of a Baath Party General Officer in the shower area of Tier 1B of the Hard Site. Tier 1B was the area of the Hard Site dedicated to female and juvenile detainees. Although Tier 1B was not the normal location for interrogations, due to a space shortage in Tier 1A, SOLDIER-17 was using this area. SOLDIER-17 witnessed an MP guard and an MP Dog Handler, whom SOLDIER-17 later identified from photographs as SOLDIER27, enter Tier 1B with SOLDIER-27's black dog. The dog was on a leash, but was not muzzled. The MP guard and MP Dog Handler opened a cell in which two juveniles, one known as "Casper," were housed. SOLDIER-27 allowed the dog to enter the cell and "go nuts on the kids," barking at and scaring them. The juveniles were screaming and the smaller one tried to hide behind "Casper." SOLDIER-27 allowed the dog to get within about one foot of the juveniles. Afterward, SOLDIER-17 overheard SOLDIER-27 say that he had a competition with another handler (likely SOLDIER-08, the only other Army dog handler) to see if they could scare detainees to the point that they would defecate. He mentioned that they had already made some detainees urinate, so they appeared to be raising the competition. This incident has no direct MI involvement; however, SOLDIER-17 failed to properly report what he observed. He stated that he went to bed and forgot the incident until asked about misuse of dogs during this investigation (Reference Annex B, Appendix 1, SOLDIER-17).

(3) (U) **Incident #27.** On 12 December 2003, an MI Hold detainee named DETAINEE-11, was recommended by MI (SOLDIER-17) for an extended stay in the Hard Site because he appeared to be mentally unstable. He was bitten by a dog in the Hard Site, but at the time he was not undergoing an interrogation and no MI personnel were present. DETAINEE-11 told SOLDIER-17 that a dog had bitten him and SOLDIER-17 saw dog bite marks on DETAINEE11's thigh. SOLDIER-08, who was the dog handler of the dog that bit DETAINEE-11, stated that in December 2003 his dog bit a detainee and he believed that MPs were the only personnel around when the incident occurred, but he declined to make further statements regarding this incident to either the MG Taguba inquiry or to this inquiry. SOLDIER-27, another Army dog handler, also stated that SOLDIER-08's dog had bitten someone, but did not provide further information. This incident was captured on digital photograph 0178/CG LAPS and appears to be the result of MP harassment and amusement, no MI involvement is suspected

SECRET//NOFORN//X1

SECRET//NOFORN//X1

SUBJECT: (U) AR 15-6 Investigation of the Abu Ghraib Detention Facility and
205th MI Brigade

(Reference Annex B, Appendix 1, SOLDIER-17; Annex B, Appendix 2, SOLDIER-08, SMITH;
Annex I, Appendix 1, Photographs, D45-54, M146-171).

(4) (U) **Incident #28.** In an apparent MI directed use of dogs in detainee abuse, circa 18 December 2003, a photograph depicts a Syrian detainee (DETAINEE-14) kneeling on the floor with his hands bound behind his back. DETAINEE-14 was a "high value" detainee who had arrived at Abu Ghraib in December 2003, from a Navy ship. DETAINEE-14 was suspected to be involved with Al-Qaeda. Military Working Dog Handler SOLDIER-27 is standing in front of DETAINEE-14 with his black dog a few feet from DETAINEE-14's face. The dog is leashed, but not muzzled. SGT Eckroth was DETAINEE-14's interrogator from 18 to 21 December 2003, and CIVILIAN-21, CACI contract interrogator, assumed the lead after SGT Eckroth departed Abu Ghraib on 22 December 2003. SGT Eckroth identified DETAINEE14 as his detainee when shown a photo of the incident. CIVILIAN-21 claimed to know nothing about this incident; however, in December 2003 he related to SSG Eckroth he was told by MPs that DETAINEE-14's bedding had been ripped apart by dogs. CIVILIAN-21 was characterized by SOLDIER25 as having a close relationship with the MPs, and she was told by SGT Frederick about dogs being used when CIVILIAN-21 was there. It is highly plausible that CIVILIAN-21 used dogs without authorization and directed the abuse in this incident as well as others related to this detainee (Reference Annex B, Appendix 1, ECKROTH, SOLDIER25, CIVILIAN-21; Annex I, Appendix 1, Photographs Z1-6).

(5) (U) **Incident #29.** On or about 14 - 15 December 2003, dogs were used in an interrogation. SPC Aston, who was the Section Chief of the Special Projects team, stated that on 14 December, one of his interrogation teams requested the use of dogs for a detainee captured in conjunction with the capture of Saddam Hussein on 13 December 2003. SPC Aston verbally requested the use of dogs from COL Pappas, and COL Pappas stated that he would call higher to request permission. This is contrary to COL Pappas's statement that he was given authority to use dogs as long as they were muzzled. About one hour later, SPC Aston received approval. SPC Aston stated that he was standing to the side of the dog handler the entire time the dog was used in the interrogation. The dog never hurt anyone and was always muzzled, about five feet away from the detainee (Reference Annex B, Appendix 1, ASTON, PAPPAS).

(6) (U) **Incident #30.** On another occasion, SOLDIER-26, an MI Soldier assigned to the S2, 320 MP BN, was present during an interrogation of a detainee and was told the detainee was suspected to have Al Qaeda affiliations. Dogs were requested and approved about three days later. SOLDIER-26 didn't know if the dog had to be muzzled or not, likely telling the dog handler to un-muzzle the dog, in contravention to CJTF-7 policy. The interrogators were CIVILIAN-20, CACI, and CIVILIAN-21 (CACI), SOLDIER-14, Operations Officer, ICE stated that CIVILIAN-21, used a dog during one of his interrogations and this is likely that occasion. According to SOLDIER-14, CIVILIAN-21 had the dog handler maintain control of the dog and

SECRET//NOFORN//X1

SECRET//NOFORN//X1

SUBJECT: (U) AR 15-6 Investigation of the Abu Ghraib Detention Facility and
205th MI Brigade

did not make any threatening reference to the dog, but apparently “felt just the presence of the dog would be unsettling to the detainee.” SOLDIER-14 did not know who approved the procedure, but was verbally notified by SOLDIER-23, who supposedly received the approval from COL Pappas. CIVILIAN-21 claimed he once requested to use dogs, but it was never approved. Based on the evidence, CIVILIAN-21 was deceitful in his statement (Reference Annex B, Appendix 1, SOLDIER-14, SOLDIER-26, CIVILIAN-21).

(7) (U) **Incident #31.** In a 14/15 December 2003 interrogation, military working dogs were used but were deemed ineffective because the detainee had little to no response to them. CIVILIAN-11, SOLDIER-05 and SOLDIER-12, all who participated in the interrogation, believed they had authority to use the dogs from COL Pappas or from LTG Sanchez; however, no documentation was found showing CJTF7 approval to use dogs in interrogations. It is probable that approval was granted by COL Pappas without such authority. LTG Sanchez stated he never approved use of dogs. (Reference Annex B, Appendix 1, CIVILIAN-11, SOLDIER-12, SOLDIER-14, PAPPAS, SOLDIER-23, CIVILIAN-21, SANCHEZ).

(8) (U) **Incident #32.** In yet another instance, SOLDIER-25, an interrogator, stated that when she and SOLDIER-15 were interrogating a female detainee in the Hard Site, they heard a dog barking. The female detainee was frightened by dogs, and SOLDIER-25 and SOLDIER-15 returned her to her cell. SOLDIER-25 went to see what was happening with the dog barking and saw a detainee in his underwear on a mattress on the floor of Tier 1A with a dog standing over him. CIVILIAN-21 was upstairs giving directions to SSG Fredrick (372 MP Co), telling him to “take him back home.” SOLDIER-25 opined it was “common knowledge that CIVILIAN-21 used dogs while he was on special projects, working directly for COL Pappas after the capture of Saddam on 13 December 2003.” SOLDIER-25 could not identify anyone else specifically who knew of this “common knowledge.” It appeared CIVILIAN-21 was encouraging and even directing the MP abuse with dogs; likely a “softening up” technique for future interrogations. The detainee was one of CIVILIAN-21’s. SOLDIER-25 did not see an interpreter in the area, so it is unlikely that CIVILIAN-21 was actually doing an interrogation.

(9) (U) SOLDIER-25 stated that SSG Frederick would come into her office every other day or so and tell her about dogs being used while CIVILIAN-21 was present. SSG Fredrick and other MPs used to refer to “doggy dance” sessions. SOLDIER-25 did not specify what “doggy dance” was (Reference Annex B, Appendix 1, SOLDIER-25), but the obvious implication is that it referred to an unauthorized use of dogs to intimidate detainees.

g. (U) Incidents of Detainee Abuse Using Humiliation. Removal of clothing was not a technique developed at Abu Ghraib, but rather a technique which was imported and can be traced through Afghanistan and GTMO. The 1987 version of FM 34-52, Interrogation, talked about “controlling all aspects of the interrogation to include... clothing given to the source,” while the

SECRET//NOFORN//X1

SECRET//NOFORN//X1SUBJECT: (U) AR 15-6 Investigation of the Abu Ghraib Detention Facility and
205th MI Brigade

current 1992 version does not. The 1987 version was, however, cited as the primary reference for CJTF-7 in Iraq, even as late as 9 June 2004. The removal of clothing for both MI and MP objectives was authorized, approved, and employed in Afghanistan and GTMO. At GTMO, the JTF 170 "Counter-Resistance Strategy," documented on 11 October 2002, permitted the removal of clothing, approved by the interrogation officer-in-charge, as an incentive in detention operations and interrogations. The SECDEF granted this authority on 2 December 2002, but it was rescinded six weeks later in January 2003. This technique also surfaced in Afghanistan. The CJTF-180 "Interrogation Techniques," documented on 24 January 2003, highlighted that deprivation of clothing had not historically been included in battlefield interrogations. However, it went on to recommend clothing removal as an effective technique that could potentially raise objections as being degrading or inhumane, but for which no specific written legal prohibition existed. As interrogation operations in Iraq began to take form, it was often the same personnel who had operated and deployed in other theaters and in support of GWOT, who were called upon to establish and conduct interrogation operations in Abu Ghraib. The lines of authority and the prior legal opinions blurred. Soldiers simply carried forward the use of nudity into the Iraqi theater of operations.

(U) Removal of clothing is not a doctrinal or authorized interrogation technique but appears to have been directed and employed at various levels within MI as an "ego down" technique. It was also employed by MPs as a "control" mechanism. Individual observation and/or understanding of the use and approval of clothing removal varied in each interview conducted by this investigation. LTC Jordan was knowledgeable of naked detainees and removal of their clothing. He denied ordering it and blamed it on the MPs. CPT Wood and SOLDIER14 claimed not to have observed nudity or approved clothing removal. Multiple MPs, interrogators, analysts, and interpreters observed nudity and/or employed clothing removal as an incentive, while an equal number didn't. It is apparent from this investigation that removal of clothing was employed routinely and with the belief it was not abuse. SOLDIER-03, GTMO Tiger Team believed that clothing as an "ego down" technique could be employed. He thought, mistakenly, that GTMO still had that authority. Nudity of detainees throughout the Hard Site was common enough that even during an ICRC visit they noted several detainees without clothing, and CPT Reese, 372 MP CO, stated upon his initial arrival at Abu Ghraib, "There's a lot of nude people here." Some of the nudity was attributed to a lack of clothing and uniforms for the detainees; however, even in these cases we could not determine what happened to the detainee's original clothing. It was routine practice to strip search detainees before their movement to the Hard Site. The use of clothing as an incentive (nudity) is significant in that it likely contributed to an escalating "de-humanization" of the detainees and set the stage for additional and more severe abuses to occur (Reference Annex I, Appendix 1, Photographs D42-43, M5-7, M17-18, M21, M137-141).

SECRET//NOFORN//X1

SECRET//NOFORN//X1

SUBJECT: (U) AR 15-6 Investigation of the Abu Ghraib Detention Facility and
205th MI Brigade

(1) (U) **Incident #33.** There is also ample evidence of detainees being forced to wear women's underwear, sometimes on their heads. These cases appear to be a form of humiliation, either for MP control or MI "ego down." DETAINEE-07 and DETAINEE-05 both claimed they were stripped of their clothing and forced to wear women's underwear on their heads. CIVILIAN-15 (CACI) and CIVILIAN-19 (CACI), a CJTF-7 analyst, alleged CIVILIAN-21 bragged and laughed about shaving a detainee and forcing him to wear red women's underwear. Several photographs include unidentified detainees with underwear on their heads. Such photos show abuse and constitute sexual humiliation of detainees (Reference Annex B, Appendix 1, SOLDIER-03, SOLDIER-14, JORDAN, REESE, CIVILIAN-21, WOOD; Annex B, Appendix 3, DETAINEE-05, CIVILIAN-15, CIVILIAN-19, DETAINEE-07; Annex C; Annex G; Annex I, Appendix 1, photographs D12, D14, M11-16).

(2) (U) **Incident #34.** On 16 September 2003, MI directed the removal of a detainee's clothing. This is the earliest incident we identified at Abu Ghraib. An MP log indicated a detainee "was stripped down per MI and he is naked (sic) and standing tall in his cell." The following day his interrogators, SPC Webster and SSG Clinscales, arrived at the detainee's cell, and he was unclothed. They were both surprised. An MP asked SSG Clinscales, a female, to stand to the side while the detainee dressed and the detainee appeared to have his clothing in his cell. SSG Clinscales was told by the MP the detainee had voluntarily removed his clothing as a protest and, in the subsequent interrogation, the detainee did not claim any abuse or the forcible removal of his clothing. It does not appear the detainee was stripped at the interrogator's direction, but someone in MI most likely directed it. SPC Webster and SOLDIER-25 provided statements where they opined SPC Claus, in charge of in-processing MI Holds, may have directed removal of detainee clothing on this and other occasions. SPC Claus denies ever giving such orders (Reference Annex B, Appendix 1, CLAUS, CLINSCALES, SOLDIER-25, WEBSTER).

(3) (U) **Incident #35.** On 19 September 2003, an interrogation "Tiger Team" consisting of SOLDIER-16, SOLDIER-07, and a civilian contract interpreter identified only as "Maher" (female), conducted a late night/early morning interrogation of a 17 year old Syrian foreign fighter. SOLDIER-16 was the lead interrogator. SOLDIER-07 was told by SOLDIER-16 that the detainee they were about to interrogate was naked. SOLDIER-07 was unsure if SOLDIER-16 was simply passing along that fact or had directed the MPs to strip the detainee. The detainee had fashioned an empty "Meals-Ready-to-Eat" (MRE) bag to cover his genital area. SOLDIER-07 couldn't recall who ordered the detainee to raise his hands to his sides, but when he did, the bag fell to the floor exposing him to SOLDIER-07 and the two female interrogation team members. SOLDIER-16 used a direct interrogation approach with the incentive of getting back clothing, and the use of stress positions.

SECRET//NOFORN//X1

SECRET//NOFORN//X1

SUBJECT: (U) AR 15-6 Investigation of the Abu Ghraib Detention Facility and
205th MI Brigade

(U) There is no record of an Interrogation Plan or any approval documents which would authorize these techniques. The fact these techniques were documented in the Interrogation Report suggests, however, that the interrogators believed they had the authority to use clothing as an incentive, as well as stress positions, and were not attempting to hide their use. Stress positions were permissible with Commander, CJTF-7 approval at that time. It is probable that use of nudity was sanctioned at some level within the chain-of-command. If not, lack of leadership and oversight permitted the nudity to occur. Having a detainee raise his hands to expose himself in front of two females is humiliation and therefore violates the Geneva Conventions (Reference Annex B, Appendix 1, SOLDIER-07, SOLDIER-14, SOLDIER-16, SOLDIER-24, WOOD).

(4) (U) **Incident #36.** In early October 2003, SOLDIER-19 was conducting an interrogation and ordered a detainee to roll his orange jumpsuit down to his waist, insinuating to the detainee that he would be further stripped if he did not cooperate. SOLDIER-19's interpreter put up his hand, looked away, said that he was not comfortable with the situation, and exited the interrogation booth. SOLDIER-19 was then forced to stop the interrogation due to lack of language support. SOLDIER-11, an analyst from a visiting JTF GTMO Tiger Team, witnessed this incident through the booth's observation window and brought it to the attention of SOLDIER-16, who was SOLDIER-19's Team Chief and first line supervisor. SOLDIER-16 responded that SOLDIER-19 knew what he was doing and did not take any action regarding the matter. SOLDIER-11 reported the same information to SOLDIER-28, his JTF GTMO Tiger Team Chief, who, according to SOLDIER-11, said he would "take care of it." SOLDIER-28 recalled a conversation with SOLDIER-11 concerning an interpreter walking out of an interrogation due to a "cultural difference," but could not remember the incident. This incident has four abuse components: the actual unauthorized stripping of a detainee by SOLDIER-19, the failure of SOLDIER-10 to report the incident he witnessed, the failure of SOLDIER-16 to take corrective action, reporting the incident up the chain of command, and the failure of SOLDIER-28 to report. (Reference Annex B, Appendix 1, SOLDIER-11, SOLDIER-16, SOLDIER-19, SOLDIER-28)

(5) (U) **Incident #37.** A photograph taken on 17 October 2003 depicts a naked detainee chained to his cell door with a hood on his head. Several other photographs taken on 18 October 2003 depict a hooded detainee cuffed to his cell door. Additional photographs on 19 October 2003 depict a detainee cuffed to his bed with underwear on his head. A review of available documents could not tie these photos to a specific incident, detainee or allegation, but these photos reinforce the reality that humiliation and nudity were being employed routinely enough that photo opportunities occurred on three successive days. MI involvement in these apparent abuses cannot be confirmed. (Reference Annex I, Appendix 1, Photographs D12, D14, D42-44, M5-7, M17-18, M21, M11-16, M137-141)

SECRET//NOFORN//X1

SECRET//NOFORN//X1

SUBJECT: (U) AR 15-6 Investigation of the Abu Ghraib Detention Facility and
205th MI Brigade

(6) (U) **Incident #38.** Eleven photographs of two female detainees arrested for suspected prostitution were obtained. Identified in these photographs are SPC Harman and CPL Graner, both MPs. In some of these photos, a criminal detainee housed in the Hard Site was shown lifting her shirt with both her breasts exposed. There is no evidence to confirm if these acts were consensual or coerced; however in either case sexual exploitation of a person in US custody constitutes abuse. There does not appear to be any direct MI involvement in either of the two incidents above. (Reference Annex I, Appendix 1, Photographs M42-52)

(7) (U) **Incident #39.** On 16 November 2003, SOLDIER-29 decided to strip a detainee in response to what she believed was uncooperative and physically recalcitrant behavior. She had submitted an Interrogation Plan in which she planned to use the "Pride and Ego Down," technique but did not specify that she would strip the detainee as part of that approach. SOLDIER-29 felt the detainee was "arrogant," and when she and her analyst, SOLDIER-10, "placed him against the wall" the detainee pushed SOLDIER-10. SOLDIER-29 warned if he touched SOLDIER-10 again, she would have him remove his shoes. A bizarre tit-for-tat scenario then ensued where SOLDIER-29 would warn the detainee about touching SOLDIER-10, the detainee would "touch" SOLDIER-10, and then had his shirt, blanket, and finally his pants removed. At this point, SOLDIER-29 concluded that the detainee was "completely uncooperative" and terminated the interrogation. While nudity seemed to be acceptable, SOLDIER-29 went further than most when she walked the semi-naked detainee across the camp. SGT Adams, SOLDIER-29's supervisor, commented that walking a semi-naked detainee across the camp could have caused a riot. CIVILIAN-21, a CACI contract interrogator, witnessed SOLDIER-29 and SOLDIER-10 escorting the scantily clad detainee from the Hard Site back to Camp Vigilant, wearing only his underwear and carrying his blanket. CIVILIAN-21 notified SGT Adams, who was SOLDIER-29's section chief, who in turn notified CPT Wood, the ICE OIC. SGT Adams immediately called SOLDIER-29 and SOLDIER-10 into her office, counseled them, and removed them from interrogation duties.

(U) The incident was relatively well known among JIDC personnel and appeared in several statements as second hand information when interviewees were asked if they knew of detainee abuse. LTC Jordan temporarily removed SOLDIER-29 and SOLDIER-10 from interrogation duties. COL Pappas left the issue for LTC Jordan to handle. COL Pappas should have taken sterner action such as an Article 15, UCMJ. His failure to do so did not send a strong enough message to the rest of the JIDC that abuse would not be tolerated. CPT Wood had recommended to LTC Jordan that SOLDIER-29 receive an Article 15 and SFC Johnson, the interrogation NCOIC, recommended she be turned over to her parent unit for the non-compliance. (Reference Annex B, Appendix 1, ADAMS, CIVILIAN-04, JORDAN, PAPPAS, SOLDIER-29, CIVILIAN-21, WOOD; Annex B, Appendix 2, JORDAN).

SECRET//NOFORN//X1

SECRET//NOFORN//X1

SUBJECT: (U) AR 15-6 Investigation of the Abu Ghraib Detention Facility and
205th MI Brigade

(8) (U) **Incident #40.** On 24 November 2003, there was a shooting of a detainee at Abu Ghraib in Tier 1A. DETAINEE-06, had obtained a pistol. While the MPs attempted to confiscate the weapon, an MP and DETAINEE-06 were shot. It was alleged that an Iraqi Police Guard had smuggled the pistol to DETAINEE-06 and in the aftermath of the shooting forty-three Iraqi Police were screened and eleven subsequently detained and interrogated. All but three were released following intense questioning. A fourth did not report for work the next day and is still at large. The Iraqi guard detainees admitted smuggling the weapons into the facility hiding them in an inner tube of a tire and several of the Iraqi guards were identified as Fedayeen trainers and members. During the interrogations of the Iraqi Police, harsh and unauthorized techniques were employed to include the use of dogs, discussed earlier in this report, and removal of clothing (See paragraph 5.e(18), above). Once detained, the police were strip-searched, which was a reasonable precaution considering the threat of contraband or weapons. Following such search, however, the police were not returned their clothes before being interrogated. This is an act of humiliation and was unauthorized. It was the general understanding that evening that LTG Sanchez and COL Pappas had authorized all measures to identify those involved, however, that should not have been construed to include abuse. LTC Jordan was the senior officer present at the interrogations and is responsible for the harsh and humiliating treatment of the police (Reference Annex B, Appendix 1, JORDAN, PAPPAS; Annex B, Appendix 2, JORDAN, PAPPAS, Annex B, Appendix 1, DETAINEE-06).

(9) (U) **Incident #41.** On 4 December 2003, documentation in the MP Logs indicated that MI leadership was aware of clothing removal. An entry indicated "Spoke with LTC Jordan (205 MI BDE) about MI holds in Tier 1A/B. He stated he would clear up with MI and let MPs run Tiers 1A/B as far as what inmate gets (clothes)." Additionally, in his statement, LTC Phillabaum claims he asked LTC Jordan what the situation was with naked detainees, and LTC Jordan responded with, "It was an interrogation technique." Whether this supports allegations of MI involvement in the clothing and stripping of detainees is uncertain, but it does show that MI at least knew of the practice and was willing to defer decisions to the MPs. Such vague guidance, if later combined with an implied tasking from MI, or perceived tasking by MP, potentially contributed to the subsequent abuse (Reference Annex B, Appendix 2, PHILLABAUM).

h. (U) Incidents of Detainee Abuse Using Isolation. Isolation is a valid interrogation technique which required approval by the CJTF-7 Commander. We identified documentation of four instances where isolation was approved by LTG Sanchez. LTG Sanchez stated he had approved 25 instances of isolation. This investigation, however, found numerous incidents of chronic confusion by both MI and MPs at all levels of command, up through CJTF-7, between the definitions of "isolation" and "segregation." Since these terms were commonly interchanged, we conclude Segregation was used far more often than Isolation. Segregation is a valid procedure to limit collaboration between detainees. This is what was employed most often in Tier 1A (putting a detainee in a cell by himself vice in a communal cell as was common outside

SECRET//NOFORN//X1

1241

SECRET//NOFORN//X1

SUBJECT: (U) AR 15-6 Investigation of the Abu Ghraib Detention Facility and
205th MI Brigade

the Hard Site) and was sometimes incorrectly referred to as "isolation." Tier 1A did have isolation cells with solid doors which could be closed as well as a small room (closet) which was referred to as the isolation "Hole." Use of these rooms should have been closely controlled and monitored by MI and MP leaders. They were not, however, which subjected the detainees to excessive cold in the winter and heat in the summer. There was obviously poor air quality, no monitoring of time limits, no frequent checks on the physical condition of the detainee, and no medical screening, all of which added up to detainee abuse. A review of interrogation reports identified ten references to "putting people in the Hole," "taking them out of the Hole," or consideration of isolation. These occurred between 15 September 2003 and 3 January 2004. (Reference Annex B, Appendix 1, SANCHEZ)

(1) (U) **Incident #42.** On 15 September 2003, at 2150 hours, unidentified MI personnel, using the initials CKD, directed the use of isolation on a unidentified detainee. The detainee in cell #9 was directed to leave his outer cell door open for ventilation and was directed to be taken off the light schedule. The identification of CKD, the MI personnel, or the detainee could not be determined. This information originated from the prison log entry and confirms the use of isolation and sensory deprivation as interrogation techniques. (Reference MP Hard Site log book entry, 15 September 2003).

(2) (U) **Incident #43.** In early October 2003, SOLDIER-11 was interrogating an unidentified detainee with SOLDIER-19, an interrogator, and an unidentified contract interpreter. About an hour and 45 minutes into the interrogation, SOLDIER-19 turned to SOLDIER-11 and asked if he thought they should place the detainee in solitary confinement for a few hours, apparently because the detainee was not cooperating or answering questions. SOLDIER-11 expressed his misgivings about the tactic, but deferred to SOLDIER-19 as the interrogator. About 15 minutes later, SOLDIER-19 stopped the interrogation, departed the booth, and returned about five minutes later with an MP, SSG Frederick. SSG Frederick jammed a bag over the detainee's head, grabbed the handcuffs restraining him and said something like "come with me piggy", as he led the detainee to solitary confinement in the Hard Site, Tier 1A of Abu Ghraib.

(U) About half an hour later, SOLDIER-19 and SOLDIER-11 went to the Hard Site without their interpreter, although he was available if needed. When they arrived at the detainee's cell, they found him lying on the floor, completely naked except for a hood that covered his head from his upper lip, whimpering, but there were no bruises or marks on him. SSG Frederick then met SOLDIER-19 and SOLDIER-11 at the cell door. He started yelling at the detainee, "You've been moving little piggy, you know you shouldn't move", or words to that effect, and yanked the hood back down over the detainee's head. SOLDIER-19 and SOLDIER-11 instructed other MPs to clothe the detainee, which they did. SOLDIER-11 then asked SOLDIER-19 if he knew the MPs were going to strip the detainee, and SOLDIER-19 said that he

SECRET//NOFORN//X1

SECRET//NOFORN//X1

SUBJECT: (U) AR 15-6 Investigation of the Abu Ghraib Detention Facility and
205th MI Brigade

did not. After the detainee was clothed, both SOLDIER-19 and SOLDIER-11 escorted him to the general population and released him without interrogating him again. SSG Frederick made the statement "I want to thank you guys, because up until a week or two ago, I was a good Christian." SOLDIER-11 is uncertain under what context SSG Frederick made this statement. SOLDIER-11 noted that neither the isolation technique, nor the "striping incident" in the cell, was in any "interrogator notes" or "interrogation plan."

(U) More than likely, SOLDIER-19 knew what SSG Frederick was going to do. Given that the order for isolation appeared to be a spontaneous reaction to the detainee's recalcitrance and not part of an orchestrated Interrogation Plan; that the "isolation" lasted only approximately half an hour; that SOLDIER-19 chose to re-contact the detainee without an interpreter present; and that SOLDIER-19 was present with SSG Frederick at another incident of detainee abuse; it is possible that SOLDIER-19 had a prearranged agreement with SSG Frederick to "soften up" uncooperative detainees and directed SSG Frederick to strip the detainee in isolation as punishment for being uncooperative, thus providing the detainee an incentive to cooperate during the next interrogation. We believe at a minimum, SOLDIER-19 knew or at least suspected this type of treatment would take place even without specific instructions (Reference Annex B, Appendix 1, SOLDIER-11, SOLDIER-19, PAPPAS, SOLDIER-28).

(3) (U) **Incident(s) #44.** On 13 November 2003, SOLDIER-29 and SOLDIER-10, MI interrogators, noted that a detainee was unhappy with his stay in isolation and visits to the hole.

(U) On 11, 13, and 14 November 2003, MI interrogators SOLDIER-04, SOLDIER-09, SOLDIER-02, and SOLDIER-23 noted that a detainee was "walked and put in the Hole," "pulled out of extreme segregation," "did not seem to be bothered to return to the Hole," "Kept in the Hole for a long time unless he started to talk," and "was in good spirits even after three days in the Hole." (Reference Annex I, Appendix 3, Photo of "the Hole").

(U) A 5 November 2003 interrogation report indicates in the recommendations/future approaches paragraph: "Detainee has been recommended for the hole in ISO. Detainee should be treated harshly because friendly treatment has not been productive and because COL Pappas wants fast resolution, or he will turn the detainee over to someone other than the 205th [MI]."

(U) On 12 November 2003, MI interrogators SOLDIER-18 and SOLDIER-13 noted that a detainee "feared the isolation Hole, and it made him upset, but not enough to break."

(U) On 29 November 2003, MI interrogators SOLDIER-18 and SOLDIER-06 told a detainee that "he would go into the Hole if he didn't start cooperating."

SECRET//NOFORN//X1

SECRET//NOFORN//X1

SUBJECT: (U) AR 15-6 Investigation of the Abu Ghraib Detention Facility and
205th MI Brigade

(U) On 8 December 2003, unidentified interrogators told a detainee that he was “recommended for movement to ISO and the Hole - he was told his sun [sunlight] would be taken away, so he better enjoy it now.”

(U) These incidents all indicate the routine and repetitive use of total isolation and light deprivation. Documentation of this technique in the interrogation reports implies those employing it thought it was authorized. The manner it was applied is a violation of the Geneva Conventions, CJTF-7 policy, and Army policy (Reference Annex M, Appendix 2, AR 190-8). Isolation was being employed without proper approval and with little oversight, resulting in abuse (Reference Annex I, Appendix 4, DETAINEE-08).

i. (U) Several alleged abuses were investigated and found to be unsubstantiated. Others turned out to be no more than general rumor or fabrication. This investigation established a threshold below which information on alleged or potential abuse was not included in this report. Fragmentary or difficult to understand allegations or information at times defied our ability to investigate further. One such example is contained in a statement from an alleged abuse victim, DETAINEE-13, who claimed he was always treated well at Abu Ghraib but was abused earlier by his captors. He potentially contradicts that claim by stating his head was hit into a wall. The detainee appears confused concerning the times and locations at which he was abused. Several incidents involved numerous victims and/or occurred during a single “event,” such as the Iraqi Police Interrogations on 24 November 2003. One example receiving some visibility was a report by SOLDIER-22 who overheard a conversation in the “chow hall” between SPC Mitchell and his unidentified “friends.” SPC Mitchell was alleged to have said: “MPs were using detainees as practice dummies. They would hit the detainees as practice shots. They would apply strikes to their necks and knock them out. One detainee was so scared; the MPs held his head and told him everything would be alright, and then they would strike him. The detainees would plead for mercy and the MPs thought it was all funny.” SPC Mitchell was interviewed and denied having knowledge of any abuse. He admitted that he and his friends would joke about noises they heard in the Hard Site and say things such as “the MPs are doing their thing.” SPC Mitchell never thought anyone would take him seriously. Several associates of SPC Mitchell were interviewed (SPC Griffin, SOLDIER-12, PVT Heidenreich). All claimed their discussions with SPC Mitchell were just rumor, and they didn’t think anyone would take him seriously or construe he had personal knowledge of abuse. SPC Mitchell’s duties also make it unlikely he would have witnessed any abuse. He arrived at Abu Ghraib as an analyst, working the day shift, in late November 2003. Shortly after his arrival, the 24 November “shooting incident” occurred and the following day, he was moved to Camp Victory for three weeks. Upon his return, he was transferred to guard duty at Camp Wood and Camp Steel and never returned to the Hard Site. This alleged abuse is likely an individual’s boastful exaggeration of a rumor which was rampant throughout Abu Ghraib, nothing more (Reference Annex B, Appendix 1, SOLDIER-12, GRIFFIN, HEIDENREICH, MITCHELL, SOLDIER-22).

SECRET//NOFORN//X1

SECRET//NOFORN//X1

SUBJECT: (U) AR 15-6 Investigation of the Abu Ghraib Detention Facility and 205th MI Brigade

Allegations of Abuse Incidents, the Nature of Reported Abuse, and Associated Personnel
 Note: The chart lists all allegations considered. The specific abuse claimed and entities involved are not confirmed in all cases. The category of abuse are underlined>. (See paragraph 5e-h, above)

Date/ Time	Incident	Nature of Alleged Abuse				Comments
		Nudity/ Humiliation	Assault	Sexual Assault	Use of Dogs The "Hole"	
15 SEP 03/ 2150	Use of Isolation. Incident #42.				MI/MP	MP log entry confirms MI use of isolation and sensory deprivation as an interrogation technique.
16 SEP 03/ 1315- 1445	MI Directs Removal of Clothing. Incident #34.	MI/MP				MPs respond to MI tasking. Detainee apparently stripped upon arrival to Hard Site at MI direction.
19-20 SEP 03	Naked Detainee During Interrogation. Incident #35.	MI/MP				
20 SEP 03	Two MI Soldiers Beat and Kicked a Cuffed Detainee. Incident #1.		MI			CID investigated and referred the case back to the command.

SECRET//NOFORN//X1

SECRET//NOFORN//X1

SUBJECT: (U) AR 15-6 Investigation of the Abu Ghraib Detention Facility and 205th MI Brigade

Allegations of Abuse Incidents, the Nature of Reported Abuse, and Associated Personnel
 Note: The chart lists all allegations considered. The specific abuse claimed and entities involved are not confirmed in all cases. The category of abuse are underlined>. (See paragraph 5e-1, above)

Date/ Time	Incident	Nature of Alleged Abuse				Comments
		Nudity/ Humiliation	Assault	Sexual Assault	Use of Dogs "Hole"	
7 OCT 03	Unauthorized Interrogation and Alleged Assault of a Female Detainee. Incident #2.	MI		MI		Unauthorized interrogation. MI personnel received Field Grade Article 15s.
Early OCT 03	Interrogator Directs Partial Removal of Clothing/Failure to Report. Incident #36.	MI				
Early OCT 03	Interrogator Directs Unauthorized Solitary Confinement/Military Police Stripping of Detainee/Failure to Report. Incident #43.	MP	MP		MI/MP	MI directed the MP place the detainee in solitary confinement (apparently the "Hole") for a few hours. The MPs carried out the request, stripped and hooded the detainee.

SECRET//NOFORN//X1

SECRET//NOFORN//X1

SUBJECT: (U) AR 15-6 Investigation of the Abu Ghraib Detention Facility and 205th MI Brigade

Allegations of Abuse Incidents, the Nature of Reported Abuse, and Associated Personnel
 Note: The chart lists all allegations considered. The specific abuse claimed and entities involved are not confirmed in all cases. The category of abuse are underlined. (See paragraph 5e-h, above)

Date/ Time	Incident	Nature of Alleged Abuse				Comments
		Nudity/ Humiliation	Assault	Sexual Assault	Use of Dogs The "Hole"	
17 OCT 03 - 19 Oct 03	Photos Depicting a Naked Hooded Detainee Cuffed to His Cell Door. Detainee Cuffed to His Bed with Underwear on his Head. Incident #37.	UNK				Nudity, hooding, and restraint. No indication of association with MI.
20 OCT 03	Detainee Was Stripped and Abused for Making a Shank from a Toothbrush. Incident #8.	MP	MP	MP		No indication of association with MI.
25 OCT 03/2015 (est)	Photos of a Naked Detainee on a Dog Leash. Incident #9.	MP		MP		Humiliation and degradation. No indication of association with MI.

SECRET//NOFORN//X1

SECRET//NOFORN//X1

SUBJECT: (U) AR 15-6 Investigation of the Abu Ghraib Detention Facility and 205th MI Brigade

Allegations of Abuse Incidents, the Nature of Reported Abuse, and Associated Personnel
 Note: The chart lists all allegations considered. The specific abuse claimed and entities involved are not confirmed in all cases. The category of abuse are underlined>. (See paragraph 5c-h, above)

Date/ Time	Incident	Nature of Alleged Abuse				Comments
		Nudity/ Humiliation	Assault	Sexual Assault	Use of Dogs "Hole"	
25 OCT 03/ 2300 - 2317 (est)	Three Naked Detainees Handcuffed Together and Forced to Simulate Sex While Photographed and Abused. Incident #3.	MI/MP	MI/MP	MI/MP		Incident not associated with interrogation operations. MI personnel observed and participated as individuals.
28 OCT 03	Photographs of Female Detainees. Incident #38.	MP		MP		MPs took many photos of two female detainees. One detainee photographed exposing her breasts.
OCT 03	Abuse and Sodomy of a Detainee (Chem Light Incident). Incident #5.	MP	MP	MP		Detainee on MI Hold. No other indication of association with MI.

SECRET//NOFORN//X1

SECRET//NOFORN//X1

SUBJECT: (U) AR 15-6 Investigation of the Abu Ghraib Detention Facility and 205th MI Brigade

Allegations of Abuse Incidents, the Nature of Reported Abuse, and Associated Personnel
 Note: The chart lists all allegations considered. The specific abuse claimed and entities involved are not confirmed in all cases. The category of abuse are underlined>. (See paragraph 5c-h, above)

Date/ Time	Incident	Nature of Alleged Abuse				Comments
		Nudity/ Humiliation	Assault	Sexual Assault	Use of Dogs "Hole"	
OCT 03	Detainee's Chin Lacerated. Incident #21.		<u>MP</u>			No indication of association with MI. Assailant unknown.
4 NOV 03/2140 - 2315	Detainee Forced to Stand on a Box With Stimulated Electrical Wires Attached to his Fingers and Penis. Incident #10.	MP		<u>MP</u>		No indication of association with MI. Attached wire to penis. Threatened detainee with electrocution
4 NOV 03	CIA Detainee Dies in Custody. Incident #7.		<u>CIA</u>			SEAL Team involved in apprehending detainee. MP's photographed body. Tampered with evidence
5 NOV 03	Detainee Forced to Stand on Boxes, Water is Poured on Him, His Genitals are Hit. Incident #20.	MP	<u>MP</u>	<u>MP</u>		Detainee on MI Hold. No other indication of association with MI.

SECRET//NOFORN//X1

SECRET//NOFORN//X1

SUBJECT: (U) AR 15-6 Investigation of the Abu Ghraib Detention Facility and 205th MI Brigade

Allegations of Abuse Incidents, the Nature of Reported Abuse, and Associated Personnel
 Note: The chart lists all allegations considered. The specific abuse claimed and entities involved are not confirmed in all cases. The category of abuse are underlined>. (See paragraph 5e-h, above)

Date/ Time	Incident	Nature of Alleged Abuse				Comments
		Nudity/ Humiliation	Assault	Sexual Assault	Use of Dogs "Hole"	
7-8 NOV 03/ 2315 - 0024 (est)	Naked "Dog pile and Forced Masturbation of Detainees Following the 6 NOV 03 Riot at Camp Vigilant. Incident #11.	MP	MP	MP		
13 NOV 03	Detainee Claim of MP Abuse Corresponds with Interrogations. Incident #4.	MP	MP			Interrogation reports suggest MI directed abuse. Withholding of bedding
14 NOV 03	MP Log-Detainees Were Ordered "PT'd" By MI. Incident #6.	MP	MP			MPs performed unauthorized medical procedures - stitching detainee wounds

SECRET//NOFORN//X1

SECRET//NOFORN//X1

SUBJECT: (U) AR 15-6 Investigation of the Abu Ghraib Detention Facility and 205th MI Brigade

Allegations of Abuse Incidents, the Nature of Reported Abuse, and Associated Personnel
 Note: The chart lists all allegations considered. The specific abuse claimed and entities involved are not confirmed in all cases. The category of abuse are underlined. (See paragraph 5e-h, above)

Date/ Time	Incident	Nature of Alleged Abuse				Comments
		Nudity/ Humiliation	Sexual Assault	Use of Dogs	The "Hole" Other	
16 NOV 03	Stripping of Detainee During Interrogation. Incident #39.	<u>MI</u>				MI interrogator counseled and removed as lead interrogator.
18 NOV 03	Photo Depicting Detainee on the Floor with a Banana Inserted into his Anus. Incident #14.		<u>MP</u>			Detainee had an apparent mental disorder. Photos were taken of him on other dates including showing him naked, praying upside down or covered in feces; blood on a door from an apparently self-inflicted wound; and efforts to restrain him. Appropriate psychiatric care and facilities apparently were not available.
24 NOV 03	MP CPT Beat and Kicked a Detainee. Incident #23.		<u>MP</u>			Subsequent investigation determined to be a staged event and not an abusive incident.

SECRET//NOFORN//X1

SECRET//NOFORN//X1

SUBJECT: (U) AR 15-6 Investigation of the Abu Ghraib Detention Facility and 205th MI Brigade

Allegations of Abuse Incidents, the Nature of Reported Abuse, and Associated Personnel
 Note: The chart lists all allegations considered. The specific abuse claimed and entities involved are not confirmed in all cases. The category of abuse are underlined. (See paragraph 5c-h, above)

Date/Time	Incident	Nature of Alleged Abuse				Comments
		Nudity/Humiliation	Assault	Sexual Assault	Use of Dogs "Hole"	
24 NOV 03	Interrogator Threatens Use of Military Working Dog. Incident #25.				MP/MI	
24 NOV 03	The use of dogs and humiliation (clothing removal) was approved by MI. Incident #40.	MI/MP			MI/MP	COL Pappas authorized, and LTC Jordan supervised, the harsh treatment of Iraqi Police during interrogations, to include humiliation (clothing removal) and the use of dogs.
26 or 27 Nov 03	MI/MP Abuse During an Interrogation of Iraqi Policeman. Incident #15.		MI/MP			MP cutoff air supply by covering nose and mouth of detainee and twisted his arm at direction of contract interrogator during interrogation of Iraqi policeman.
29 NOV 04	Photo Depicting a detainee in his underwear standing on a box. Incident #13.	UNK	UNK			Photo could not be tied to any specific incident, detainee, or allegation and MI involvement is indeterminate.

SECRET//NOFORN//X1

SECRET//NOFORN//X1

SUBJECT: (U) AR 15-6 Investigation of the Abu Ghraib Detention Facility and 205th MI Brigade

Allegations of Abuse Incidents, the Nature of Reported Abuse, and Associated Personnel
 Note: The chart lists all allegations considered. The specific abuse claimed and entities involved are not confirmed in all cases. The category of abuse are underlined>. (See paragraph 5c-h, above)

Date/ Time	Incident	Nature of Alleged Abuse				Comments	
		Nudity/ Humiliation	Assault	Sexual Assault	Use of Dogs The "Hole"		Other
30 NOV 03	MP Log Entry- Detainee Was Found in Cell Covered in Blood. Incident #17.		UNK				Wounds apparently self-inflicted. No indication of association with MI.
Circa Dec 03	Photo Depicting detainee in stress position on chair. Incident #24.		MI				Photo shows detainee kneeling on a chair with interrogators watching. No associated interrogation summaries to ID detainee
4 DEC 03	MP Log- Determination of Inmate Clothing by MI. Incident #41.	MI/MP					Suggests MI direction to remove selected detainee's clothing, with MP collaboration.

SECRET//NOFORN//X1

SECRET//NOFORN//X1

SUBJECT: (U) AR 15-6 Investigation of the Abu Ghraib Detention Facility and 205th MI Brigade

Allegations of Abuse Incidents, the Nature of Reported Abuse, and Associated Personnel
 Note: The chart lists all allegations considered. The specific abuse claimed and entities involved are not confirmed in all cases. The category of abuse are underlined>. (See paragraph 5c-h, above)

Date/ Time	Incident	Nature of Alleged Abuse				Comments
		Nudity/ Humiliation	Assault	Sexual Assault	Use of Dogs "Hole"	
12-13 DEC 03 (est)	Detainee Involved in Attempted Murder of MPs Claims Retaliatory Acts Upon Return to the Hard Site. Incident #18.		MP		MP	Detainee allegations may have been exaggerated. MP – Forced him to eat pork and forced alcohol in his mouth. MPs may have retaliated in response to the detainee shooting an MP on 24 NOV 03.
4-13 DEC 03 (est)	Withholding of Clothing, Bedding, and Medical Care. Incident #19.	MP	UNK			MI Soldier discovered and attempted to rectify the situation. A U/I COL or LTC medical officer refused to remove a catheter when notified by MI.
12 DEC 03	Dog Bites Iranian Detainee. Incident #27.	MP	MP		MP	Detainee on MI Hold. No other indication of association with MI.
14/15 DEC 03	MI Uses Dog in Interrogation. Incident #29.				MI/MP	Used allegedly in response to COL Pappas's blanket approval for use of harsher techniques against Saddam associates.

SECRET//NOFORN//X1

SECRET//NOFORN//X1

SUBJECT: (U) AR 15-6 Investigation of the Abu Ghraib Detention Facility and 205th MI Brigade

Allegations of Abuse Incidents, the Nature of Reported Abuse, and Associated Personnel
 Note: The chart lists all allegations considered. The specific abuse claimed and entities involved are not confirmed in all cases. The category of abuse are underlined>. (See paragraph 5e-h, above)

Date/Time	Incident	Nature of Alleged Abuse				Comments
		Nudity/Humiliation	Assault	Sexual Assault	Use of Dogs "Hole" Other	
14/15 DEC 03	MI Uses Dog in Interrogation. Incident #31.				MI/MP	Interrogation report indicates dogs used with little effect during an interrogation.
Late DEC 03	Interrogator Possibly Involved in Dog Use on Detainee. Incident #32.				MI/MP	
18 DEC 03 or later	Dog Handler Uses Dog on Detainee. Incident #28.				MP	Photos of incident show only MP personnel; however, it is possible MI directed the dogs to prepare the detainee for interrogation.
27 DEC 03 (est)	Photo Depicting Apparent Shotgun Wounds on Detainee's Buttocks. Incident #12.	UNK	UNK			Detainee apparently shot by MP personnel with shotgun using less-than-lethal rounds. Nudity may have been required to have medics observe and treat wounds. No indication of association with MI.

SECRET//NOFORN//X1

SECRET//NOFORN//X1

SUBJECT: (U) AR 15-6 Investigation of the Abu Ghraib Detention Facility and 205th MI Brigade

Allegations of Abuse Incidents, the Nature of Reported Abuse, and Associated Personnel
 Note: The chart lists all allegations considered. The specific abuse claimed and entities involved are not confirmed in all cases. The category of abuse are underlined>. (See paragraph 5c-h, above)

Date/ Time	Incident	Nature of Alleged Abuse				Comments
		Nudity/ Humiliation	Assault	Sexual Assault	Use of Dogs The "Hole"	
8 JAN 04 (Estimat ed)	Dog Used to Scare Juvenile Inmates. Incident #26.				<u>MP</u>	MI Soldier observed the event while in the area during an interrogation. MP motivation unknown. MI Soldier failed to report it.
Unspeci fied	Un-muzzled dog used during an interrogation. Incident #30.				<u>MI/MP</u>	MI approved the use of dogs during an interrogation. The dog was un-muzzled without such approval.
Unspeci fied	Possible Rape of a Detainee by a US Translator. Incident #22.				<u>MI</u>	

SECRET//NOFORN//X1

SECRET//NOFORN//X1

SUBJECT: (U) AR 15-6 Investigation of the Abu Ghraib Detention Facility and 205th MI Brigade

Allegations of Abuse Incidents, the Nature of Reported Abuse, and Associated Personnel
 Note: The chart lists all allegations considered. The specific abuse claimed and entities involved are not confirmed in all cases. The category of abuse are underlined>. (See paragraph 5c-h, above)

Date/ Time	Incident	Nature of Alleged Abuse				Comments	
		Nudity/ Humiliation	Assault	Sexual Assault	Use of Dogs The "Hole"		Other
Unspecified	Civilian Interrogator Forcibly Pulls Detainee from Truck and Drags Him Across Ground. Incident #16.		MI				The incident was reported by MI, but CID apparently did not pursue the case.
Various Dates	MI Use of Isolation as an Interrogation Technique. Incident #44.				MI/MP		Seven detainees are associated with this line item.
Various Dates	MI Forces Detainee to Wear Women's Underwear on his Head. Incident #33.	MI/MP					MPs may have performed two of the incidents identified in photos, and may have no MI association.

SECRET//NOFORN//X1

SECRET//NOFORN//X1

SUBJECT: (U) AR 15-6 Investigation of the Abu Ghraib Detention Facility and
205th MI Brigade

6. (U) Findings and Recommendations.

a. (U) **Major Finding:** From 25 July 2003 to 6 February 2004, twenty-seven (27) 205 MI BDE personnel allegedly:

- Requested, encouraged, condoned, or solicited MP personnel to abuse detainees or;
- Participated in detainee abuse or;
- Violated established interrogation procedures and applicable laws and regulations as preparation for interrogation operations at Abu Ghraib.

(U) **Explanation:** Some MI personnel encouraged, condoned, participated in, or ignored abuse. In a few instances, MI personnel acted alone in abusing detainees. MI abuse and MI solicitation of MP abuse included the use of isolation with sensory deprivation ("the Hole"), removal of clothing and humiliation, the use of dogs to "fear up" detainees, and on one occasion, the condoned twisting of a detainee's cuffed wrists and the smothering of this detainee with a cupped hand in MI's presence. Some MI personnel violated established interrogation practices, regulations, and conventions which resulted in the abuse of detainees. While Interrogation and Counter-Resistance Policies (ICRP) were poorly defined and changed several times, in most cases of detainee abuse the MI personnel involved knew or should have known what they were doing was outside the bounds of their authority. Ineffective leadership at the JIDC failed to detect violations and discipline those responsible. Likewise, leaders failed to provide adequate training to ensure Soldiers understood the rules and complied.

(U) **Recommendation:** The Army needs to re-emphasize Soldier and leader responsibilities in interrogation and detention operations and retrain them to perform in accordance with law, regulations, and Army values and to live up to the responsibilities of their rank and position. Leaders must also provide adequate training to ensure Soldiers understand their authorities. The Army must ensure that future interrogation policies are simple, direct and include safeguards against abuse. Organizations such as the JIDC must possess a functioning chain of command capable of directing interrogation operations.

b. (U) Other Findings and Recommendations.

(1) (U) **Finding:** There was a lack of clear Command and Control of Detainee Operations at the CJTF-7 level.

(U) **Explanation:** COL Pappas was rated by MG Wojdakowski, DCG, V Corps/CJTF-7. MG Wojdakowski, however, was not directly involved with interrogation operations. Most of COL Pappas' direction was coming from LTG Sanchez directly as well as from MG Fast, the C2.

SECRET//NOFORN//X1

SECRET//NOFORN//X1

SUBJECT: (U) AR 15-6 Investigation of the Abu Ghraib Detention Facility and
205th MI Brigade

BG Karpinski was rated by BG Diamond, Commander, 377th Theater Support Command (377 TSC). However, she testified that she believed her rater was MG Wojdakowski and in fact it was he she received her direction from the entire time she was in Iraq (Reference Annex B, Appendix 1, KARPINSKI). The 800 MP BDE was TACON to CJTF-7. Overall responsibility for detainee operations never came together under one person short of LTG Sanchez himself until the assignment of MG G. Miller in April 2004.

(U) **Recommendation:** There should be a single authority designated for command and control for detention and interrogation operations. (DoD/DA)

(2) (U) **Finding:** FRAGO 1108 appointing COL Pappas as FOB Commander at Abu Ghraib was unclear. This issue did not impact detainee abuse.

(U) **Explanation:** Although FRAGO 1108 appointing COL Pappas as FOB Commander on 19 November 2003 changed the command relationship, it had no specific effect on detainee abuses at Abu Ghraib. The FRAGO giving him TACON of the 320 MP BN did not contain any specified or implied tasks. The TACON did not include responsibility for conducting prison or "Warden" functions. Those functions remained the responsibility of the 320 MP BN. This FRAGO has been cited as a significant contributing factor that allowed the abuses to happen, but the abuses were already underway for two months before CJTF-7 issued this FRAGO. COL Pappas and the Commander of the 320 MP BN interpreted that FRAGO strictly for COL Pappas to exercise the external Force Protection and Security of Detainees. COL Pappas had a Long Range Reconnaissance Company in the 165 MI BN that would augment the external protection of Abu Ghraib. The internal protection of detainees, however, still remained the responsibility of the 320 MP BN. The confusion and disorganization between MI and MPs already existed by the time CJTF-7 published the FRAGO. Had there been no change of FOB Command, it is likely abuse would have continued anyway.

(U) **Recommendation:** Joint Task Forces such as CJTF-7 should clearly specify relationships in FRAGOs so as to preclude confusion. Terms such as Tactical Control (TACON) should be clearly defined to identify specific command relationships and preclude confusion. (DoD/CJTF-7)

(3) (U) **Finding:** The JIDC was manned with personnel from numerous organizations and consequently lacked unit cohesion. There was an absence of an established, effective MI chain of command at the JIDC.

(U) **Explanation:** A decision was made not to run the JIDC as a unit mission. The JIDC was manned, led and managed by staff officers from multiple organizations as opposed to a unit with its functioning chain of command. Responsibilities for balancing the demands of

SECRET//NOFORN//X1

SECRET//NOFORN//X1

SUBJECT: (U) AR 15-6 Investigation of the Abu Ghraib Detention Facility and
205th MI Brigade

managing interrogation operations and establishing good order and discipline in this environment were unclear and lead to lapses in accountability.

(U) **Recommendation:** JIDCs need to be structured, manned, trained and equipped as standard military organizations. These organizations should be certified by TRADOC and/or JFCOM. Appropriate Army and Joint doctrine should be developed defining JIDCs' missions and functions as separate commands. (DoD/DA/CJTF-7)

(4) (U) **Finding:** Selecting Abu Ghraib as a detention facility placed soldiers and detainees at an unnecessary force protection risk.

(U) **Explanation:** Failure adequately to protect and house detainees is a violation of the Third and Fourth Geneva Conventions and AR 190-8. Therefore, the selection of Abu Ghraib as a detention facility was inappropriate because of its inherent indefensibility and poor condition. The selection of Abu Ghraib as a detention center was dictated by the Coalition Provisional Authority officials despite concerns that the Iraqi people would look negatively on Americans interning detainees in a facility associated with torture. Abu Ghraib was in poor physical condition with buildings and sections of the perimeter wall having been destroyed, resulting in completely inadequate living conditions. Force protection must be a major consideration in selecting any facility as a detention facility. Abu Ghraib was located in the middle of the Sunni Triangle, an area known to be very hostile to coalition forces. Further, being surrounded by civilian housing and open fields and encircled by a network of roads and highways, its defense presented formidable force protection challenges. Even though the force protection posture at Abu Ghraib was compromised from the start due to its location and poor condition, coalition personnel still had a duty and responsibility to undertake appropriate defensive measures. However, the poor security posture at Abu Ghraib resulted in the deaths and wounding of both coalition forces and detainees.

(U) **Recommendations:**

- Detention centers must be established in accordance with AR 190-8 to ensure safety and compliance with the Geneva Conventions. (DoD/DA/CJTF-7).
- As a matter of policy, force protection concerns must be applicable to any detention facility and all detention operations. (DoD/DA/CJTF-7)
- Protect detainees in accordance with Geneva Convention IV by providing adequate force protection. (DoD/DA/CJTF-7)

(5) (U) **Finding:** Leaders failed to take steps to effectively manage pressure placed upon JIDC personnel.

(U) **Explanation:** During our interviews, leaders within the MI community commented upon the intense pressure they felt from higher headquarters, to include CENTCOM,

SECRET//NOFORN//X1

SECRET//NOFORN//X1

SUBJECT: (U) AR 15-6 Investigation of the Abu Ghraib Detention Facility and
205th MI Brigade

the Pentagon, and DIA for timely, actionable intelligence (Reference Annex B, Appendix 1, WOOD, PAPPAS, and PRICE). These leaders have stated that this pressure adversely affected their decision making. Requests for information were being sent to Abu Ghraib from a number of headquarters without any prioritization. Based on the statements from the interrogators and analysts, the pressure was allowed to be passed down to the lowest levels.

(U) **Recommendation:** Leaders must balance mission requirements with unit capabilities, soldier morale and effectiveness. Protecting Soldiers from unnecessary pressure to enhance mission effectiveness is a leader's job. Rigorous and challenging training can help prepare units and soldiers for the stress they face in combat. (DoD/DA/CENTCOM/CJTF-7)

(6) (U) **Finding:** Some capturing units failed to follow procedures, training, and directives in the capture, screening, and exploitation of detainees.

(U) **Explanation:** The role of the capturing unit was to conduct preliminary screening of captured detainees to determine if they posed a security risk or possessed information of intelligence value. Detainees who did not pose a security risk and possessed no intelligence value should have been released. Those that posed a security risk and possessed no intelligence value should have been transferred to Abu Ghraib as a security hold. Those that possessed intelligence information should have been interrogated within 72 hours at the tactical level to gather perishable information of value to the capturing unit. After 72 hours, these personnel should have been transferred to Abu Ghraib for further intelligence exploitation as an MI hold. Since most detainees were not properly screened, large numbers of detainees were transferred to Abu Ghraib, who in some cases should not have been sent there at all, and in almost all cases, were not properly identified or documented in accordance with doctrine and directives. This failure led to the arrival of a significant number of detainees at Abu Ghraib. Without proper detainee capture documentation, JIDC interrogators were diverted from interrogation and intelligence production to screening operations in order to assess the value of the incoming detainees (no value, security hold, or MI Hold). The overall result was that less intelligence was produced at the JIDC than could have been if capturing forces had followed proper procedures.

(U) **Recommendation:** Screening, interrogation and release procedures at the tactical level need to be properly executed. Those detainees who pose no threat and are of no intelligence value should be released by capturing units within 72 hours. Those detainees thought to be a threat but of no further intelligence value should be sent to a long term confinement facility. Those detainees thought to possess further intelligence value should be sent to a Corps/Theater Interrogation Center. (DA/CENTCOM/CJTF-7)

(7) (U) **Finding:** DoD's development of multiple policies on interrogation operations for use in different theaters or operations confused Army and civilian Interrogators at Abu Ghraib.

SECRET//NOFORN//X1

~~SECRET//NOFORN//X1~~

SUBJECT: (U) AR 15-6 Investigation of the Abu Ghraib Detention Facility and
205th MI Brigade

(U) **Explanation:** National policy and DoD directives were not completely consistent with Army doctrine concerning detainee treatment or interrogation tactics, resulting in CJTF-7 interrogation and counter-resistance policies and practices that lacked basis in Army interrogation doctrine. As a result, interrogators at Abu Ghraib employed non-doctrinal approaches that conflicted with other DoD and Army regulatory, doctrinal and procedural guidance.

(U) **Recommendation:** Adopt one DoD policy for interrogation, within the framework of existing doctrine, adhering to the standards found in doctrine, and enforce that standard policy across DoD. Interrogation policy must be simple and direct, with reference to existing doctrine, and possess effective safeguards against abuse. It must be totally understandable by the interrogator using it. (DoD/DA/CJTF-7)

(8) (U) **Finding:** There are an inadequate number of MI units to satisfy current and future HUMINT missions. The Army does not possess enough interrogators and linguists to support interrogation operations.

(U) **Explanation:** The demand for interrogators and linguists to support tactical screening operations at the point-of-capture of detainees, tactical HUMINT teams, and personnel to support interrogation operations at organizations like the JIDC cannot be supported with the current force structure. As a result, each of these operations in Iraq was undermanned and suffered accordingly.

(U) **Recommendation:** The Army must increase the number of HUMINT units to overcome downsizing of HUMINT forces over the last 10 years and to address current and future HUMINT requirements.

(9) (U) **Finding:** The JIDC was not provided with adequate personnel resources to effectively operate as an interrogation center.

(U) **Explanation:** The JIDC was established in an ad hoc manner without proper planning, personnel, and logistical support for the missions it was intended to perform. Interrogation and analyst personnel were quickly kluged together from a half dozen units in an effort to meet personnel requirements. Even at its peak strength, interrogation and analyst manpower at the JIDC was too shorthanded to deal with the large number of detainees at hand. Logistical support was also inadequate.

(U) **Recommendation:** The Army and DoD should plan on operating JIDC organizations in future operational environments, establish appropriate manning and equipment authorizations for the same. (DoD/DA)

~~SECRET//NOFORN//X1~~

SECRET//NOFORN//X1

SUBJECT: (U) AR 15-6 Investigation of the Abu Ghraib Detention Facility and
205th MI Brigade

(10) (U) **Finding:** There was/is a severe shortage of CAT II and CAT III Arab linguists available in Iraq.

(U) **Explanation:** This shortage negatively affected every level of detainee operations from point-of-capture through detention facility. Tactical units were unable to properly screen detainees at their levels not only because of the lack of interrogators but even more so because of the lack of interpreters. The linguist problem also existed at Abu Ghraib. There were only 20 linguists assigned to Abu Ghraib at the height of operations. Linguists were a critical node and limited the maximum number of interrogations that could be conducted at any time to the number of linguists available.

(U) **Recommendation:** Army and DoD need to address the issue of inadequate linguist resources to conduct detention operations. (DA/DoD)

(11) (U) **Finding:** The cross leveling of a large number of Reserve Component (RC) Soldiers during the Mobilization process contributed to training challenges and lack of unit cohesion of the RC units at Abu Ghraib.

(U) **Recommendation:** If cross leveling of personnel is necessary in order to bring RC units up to required strength levels, then post mobilization training time should be extended. Post mobilization training should include unit level training in addition to Soldier training to ensure cross leveled Soldiers are made part of the team. (DA)

(12) (U) **Finding:** Interrogator training in the Laws of Land Warfare and the Geneva Conventions is ineffective.

(U) **Explanation:** The US Army Intelligence Center and follow on unit training provided interrogators with what appears to be adequate curriculum, practical exercises and man-hours in Law of Land Warfare and Geneva Conventions training. Soldiers at Abu Ghraib, however, remained uncertain about what interrogation procedures were authorized and what proper reporting procedures were required. This indicates that Initial Entry Training for interrogators was not sufficient or was not reinforced properly by additional unit training or leadership.

(U) **Recommendation:** More training emphasis needs to be placed on Soldier and leader responsibilities concerning the identification and reporting of detainee abuse incidents or concerns up through the chain of command, or to other offices such as CID, IG or SJA. This training should not just address the rules, but address case studies from recent and past detainee and interrogation operations to address likely issues interrogators and their supervisors will encounter. Soldiers and leaders need to be taught to integrate Army values and ethical decision-

SECRET//NOFORN//X1

SECRET//NOFORN//X1

SUBJECT: (U) AR 15-6 Investigation of the Abu Ghraib Detention Facility and
205th MI Brigade

making to deal with interrogation issues that are not clearly prohibited or allowed. Furthermore, it should be stressed that methods employed by US Army interrogators will represent US values.

(13) (U) **Finding:** MI, MP, and Medical Corps personnel observed and failed to report instances of Abuse at Abu Ghraib. Likewise, several reports indicated that capturing units did not always treat detainees IAW the Geneva Convention.

(U) **Recommendation:** DoD should improve training provided to all personnel in Geneva Conventions, detainee operations, and the responsibilities of reporting detainee abuse. (DoD)

(14) (U) **Finding:** Combined MI/MP training in the conduct of detainee/interrogation operations is inadequate.

(U) **Explanation:** MI and MP personnel at Abu Ghraib had little knowledge of each other's missions, roles and responsibilities in the conduct of detainee/interrogation operations. As a result, some "lances in the road" were worked out "on the fly." Other relationships were never fully defined and contributed to the confused operational environment.

(U) **Recommendation:** TRADOC should initiate an effort to develop a cross branch training program in detainee and interrogation operations training. FORSCOM should reinstitute combined MI/MP unit training such as the Gold Sword/Silver Sword Exercises that were conducted annually. (DA)

(15) (U) **Finding:** MI leaders do not receive adequate training in the conduct and management of interrogation operations.

(U) **Explanation:** MI Leaders at the JIDC were unfamiliar with and untrained in interrogation operations (with the exception of CPT Wood) as well as the mission and purposes of a JIDC. Absent any knowledge from training and experience in interrogation operations, JIDC leaders had to rely upon instinct to operate the JIDC. MTTs and Tiger Teams were deployed to the JIDC as a solution to help train interrogators and leaders in the management of HUMINT and detainee/interrogator operations.

(U) **Recommendation:** MI Officer, NCO and Warrant Officer training needs to include interrogation operations to include management procedures, automation support, collection management and JIDC operations. Officer and senior NCO training should also emphasize the potential for abuse involved in detention and interrogation operations. (DA)

SECRET//NOFORN//X1

SECRET//NOFORN//X1

SUBJECT: (U) AR 15-6 Investigation of the Abu Ghraib Detention Facility and
205th MI Brigade

(16) (U) **Finding:** Army doctrine exists for both MI interrogation and MP detainee operations, but it was not comprehensive enough to cover the situation that existed at Abu Ghraib.

(U) **Explanation:** The lines of authority and accountability between MI and MP were unclear and undefined. For example, when MI would order sleep adjustment, MPs would use their judgment on how to apply that technique. The result was MP taking detainees from their cells stripping them and giving them cold showers or throwing cold water on them to keep them awake.

(U) **Recommendation:** DA should conduct a review to determine future Army doctrine for interrogation operations and detention operations. (DA)

(17) (U) **Finding:** Because of a lack of doctrine concerning detainee and interrogation operations, critical records on detainees were not created or maintained properly thereby hampering effective operations.

(U) **Explanation:** This lack of record keeping included the complete life cycle of detainee records to include detainee capture information and documentation, prison records, medical records, interrogation plans and records, and release board records. Lack of record keeping significantly hampered the ability of this investigation to discover critical information concerning detainee abuse.

(U) **Recommendation:** As TRADOC reviews and enhances detainee and interrogation operations doctrine, it should ensure that record keeping and information sharing requirements are addressed. (DA)

(18) (U) **Finding:** Four (4) contract interrogators allegedly abused detainees at Abu Ghraib.

(U) **Explanation:** The contracting system failed to ensure that properly trained and vetted linguist and interrogator personnel were hired to support operations at Abu Ghraib. The system also failed to provide useful contract management functions in support of the facility. Soldiers and leaders at the prison were unprepared for the arrival, employment, and oversight of contract interrogators.

(U) **Recommendations:** The Army should review the use contract interrogators. In the event contract interrogators must be used, the Army must ensure that they are properly qualified from a training and performance perspective, and properly vetted. The Army should establish standards for contract requirements and personnel. Additionally, the Army must

SECRET//NOFORN//X1

~~SECRET//NOFORN//X1~~

SUBJECT: (U) AR 15-6 Investigation of the Abu Ghraib Detention Facility and
205th MI Brigade

provide sufficient contract management resources to monitor contracts and contractor performance at the point of performance.

(19) (U) **Observation:** MG Miller's visit did not introduce "harsh techniques" into the Abu Ghraib interrogation operation.

(U) **Explanation:** While there was an increase in intelligence reports after the visit, it appears more likely it was due to the assignment of trained interrogators and an increased number of MI Hold detainees to interrogate. This increase in production does not equate to an increase in quality of the collected intelligence. MG G. Miller's visit did not introduce "harsh techniques" into the Abu Ghraib interrogation operation.

(20) (U) **Finding:** The JTF-GTMO training team had positive impact on the operational management of the JIDC; however, the JTF-GTMO training team inadvertently validated restricted interrogation techniques.

(U) **Explanation:** The JTF-GTMO team stressed the conduct of operations with a strategic objective, while the Abu Ghraib team remained focused on tactical operations. Instead of providing guidance and assistance, the team's impact was limited to one-on-one interaction during interrogations. Clearly a significant problem was the JTF-GTMO's lack of understanding of the approved interrogation techniques, either for GTMO or CJTF-7 or Abu Ghraib. When the training team composed of the experts from a national level operation failed to recognize, object to, or report detainee abuse, such as the use of nudity as an interrogation tactic, they failed as a training team and further validated the use of unacceptable interrogation techniques.

(U) **Recommendation:** TRADOC should initiate an Army-wide effort to ensure all personnel involved in detention and interrogation operations are properly trained with respect to approved doctrine. There should be a MTT to assist ongoing detention operations. This MTT must be of the highest quality and understand the mission they have been sent to support. They must have clearly defined and unmistakable objectives. Team members with varied experience must be careful to avoid providing any training or guidance that contradicts local or national policy. (DA/DoD)

(21) (U) **Finding:** The Fort Huachuca MTT failed to adapt the ISCT training (which was focused upon improving the JTF-GTMO operational environment) to the mission needs of CJTF-7 and JIDC; however, actions of one team member resulted in the inadvertent validation of restricted interrogation techniques.

(U) **Explanation:** Although the Fort Huachuca Team (ISCT) team was successful in arranging a few classes and providing some formal training, to include classes on the Geneva Conventions, both the JIDC leadership and the ISCT team failed to include/require the contract

~~SECRET//NOFORN//X1~~

SECRET//NOFORN//X1

SUBJECT: (U) AR 15-6 Investigation of the Abu Ghraib Detention Facility and
205th MI Brigade

personnel to attend the training. Furthermore, the training that was given was ineffective and certainly did nothing to prevent the abuses occurring at Abu Ghraib, e.g., the "Hole," nakedness, withholding of bedding, and the use of dogs to threaten detainees. The ISCT MTT members were assigned to the various Tiger Teams/sections to conduct interrogations. The ISCT team's lack of understanding of approved doctrine was a significant failure. This lack of understanding was evident in SFC Walters' "unofficial" conversation with one of the Abu Ghraib interrogators (CIVILIAN21). SFC Walters related several stories about the use of dogs as an inducement, suggesting the interrogator talk to the MPs about the possibilities. SFC Walters noted that detainees are most susceptible during the first few hours after capture. "The prisoners are captured by Soldiers, taken from their familiar surroundings, blindfolded and put into a truck and brought to this place (Abu Ghraib); and then they are pushed down a hall with guards barking orders and thrown into a cell, naked; and that not knowing what was going to happen or what the guards might do caused them extreme fear." It was also suggested that an interrogator could take some pictures of what seemed to be guards being rough with prisoners so he could use them to scare the prisoners. This conversation certainly contributed to the abusive environment at Abu Ghraib. The team validated the use of unacceptable interrogation techniques. The ISCT team's Geneva Conventions training was not effective in helping to halt abusive techniques, as it failed to train Soldiers on their responsibilities for identifying and reporting those techniques.

(U) **Recommendation:** TRADOC should initiate an Army-wide effort to ensure all personnel involved in detention and interrogation operations are properly trained with respect to approved doctrine. There should be a MTT to assist ongoing detention operations. This MTT must be of the highest quality and understand the mission they have been sent to support. They must have clearly defined and unmistakable objectives. Team members with varied experience must be careful to avoid providing any training or guidance that contradicts local or national policy. (DA/DoD)

(22) (U) **Finding:** Other Government Agency (OGA) interrogation practices led to a loss of accountability at Abu Ghraib.

(U) **Explanation:** While the FBI, JTF-121, Criminal Investigative Task Force, Iraq Survey Group, and the CIA were all present at Abu Ghraib, the acronym "Other Government Agency" referred almost exclusively to the CIA. Lack of military control over OGA interrogator actions or lack of systemic accountability for detainees plagued detainee operations in Abu Ghraib almost from the start. Army allowed CIA to house "Ghost Detainees" who were unidentified and unaccounted for in Abu Ghraib. This procedure created confusion and uncertainty concerning their classification and subsequent DoD reporting requirements under the Geneva Conventions. Additionally, the treatment and interrogation of OGA detainees occurred under different practices and procedures which were absent any DoD visibility, control, or oversight. This separate grouping of OGA detainees added to the confusion over proper treatment of detainees and created a perception that OGA techniques and practices were suitable

SECRET//NOFORN//X1

SECRET//NOFORN//X1

SUBJECT: (U) AR 15-6 Investigation of the Abu Ghraib Detention Facility and
205th MI Brigade

and authorized for DoD operations. No memorandum of understanding on detainee accountability or interrogation practices between the CIA and CJTF-7 was created.

(U) **Recommendation:** DoD must enforce adherence by OGA with established DoD practices and procedures while conducting detainee interrogation operations at DoD facilities.

(23) (U) **Finding:** There was neither a defined procedure nor specific responsibility within CJTF-7 for dealing with ICRC visits. ICRC recommendations were ignored by MI, MP and CJTF-7 personnel.

(U) **Explanation:** Within this investigation's timeframe, 16 September 2003 through 31 January 2004, the ICRC visited Abu Ghraib three times, notifying CJTF-7 twice of their visit results, describing serious violations of international Humanitarian Law and of the Geneva Conventions. In spite of the ICRC's role as independent observers, there seemed to be a consensus among personnel at Abu Ghraib that the allegations were not true. Neither the leadership, nor CJTF-7 made any attempt to verify the allegations.

(U) **Recommendation:** DoD should review current policy concerning ICRC visits and establish procedures whereby findings and recommendations made by the ICRC are investigated. Investigation should not be done by the units responsible for the facility in question. Specific procedures and responsibilities should be developed for ICRC visits, reports, and responses. There also needs to be specific inquiries made into ICRC allegations of abuse or maltreatment by an independent entity to ensure that an unbiased review has occurred. (DoD/CJTF-7)

(24) (U) **Finding:** Two soldiers that the 519 MI BN had reason to suspect were involved in the questionable death of a detainee in Afghanistan were allowed to deploy and continue conducting interrogations in Iraq. While in Iraq, those same soldiers were alleged to have abused detainees.

(U) **Recommendation:** Once soldiers in a unit have been identified as possible participants in abuse related to the performance of their duties, they should be suspended from such duties or flagged.

(25) (U) **Observation:** While some MI Soldiers acted outside the scope of applicable laws and regulations, most Soldiers performed their duties in accordance with the Geneva Conventions and Army Regulations.

(U) **Explanation:** MI Soldiers operating the JIDC at Abu Ghraib screened thousands of Iraqi detainees, conducted over 2500 interrogations, and produced several thousand valuable intelligence products supporting the war fighter and the global war on terrorism. This great effort

SECRET//NOFORN//X1

SECRET//NOFORN//X1

SUBJECT: (U) AR 15-6 Investigation of the Abu Ghraib Detention Facility and
205th MI Brigade

was executed in difficult and dangerous conditions with inadequate physical and personnel resources.

c. (U) Individual Responsibility for Detainee Abuse at Abu Ghraib.

(1) (U) **Finding:** COL Thomas M. Pappas, Commander, 205 MI BDE. A preponderance of evidence supports that COL Pappas did, or failed to do, the following:

- Failed to insure that the JIDC performed its mission to its full capabilities, within the applicable rules, regulations and appropriate procedures.
- Failed to properly organize the JIDC.
- Failed to put the necessary checks and balances in place to prevent and detect abuses.
- Failed to ensure that his Soldiers and civilians were properly trained for the mission.
- Showed poor judgment by leaving LTC Jordan in charge of the JIDC during the critical early stages of the JIDC.
- Showed poor judgment by leaving LTC Jordan in charge during the aftermath of a shooting incident known as the Iraqi Police Roundup (IP Roundup).
- Improperly authorized the use of dogs during interrogations. Failed to properly supervise the use of dogs to make sure they were muzzled after he improperly permitted their use.
- Failed to take appropriate action regarding the ICRC reports of abuse.
- Failed to take aggressive action against Soldiers who violated the ICRP, the CJTF-7 interrogation and Counter-Resistance Policy and the Geneva Conventions.
- Failed to properly communicate to Higher Headquarters when his Brigade would be unable to accomplish its mission due to lack of manpower and/or resources. Allowed his Soldiers and civilians at the JIDC to be subjected to inordinate pressure from Higher Headquarters.
- Failed to establish appropriate MI and MP coordination at the brigade level which would have alleviated much of the confusion that contributed to the abusive environment at Abu Ghraib.
- The significant number of systemic failures documented in this report does not relieve COL Pappas of his responsibility as the Commander, 205th MI BDE for the abuses that occurred and went undetected for a considerable length of time.

(U) **Recommendation:** This information should be forwarded to COL Pappas' chain of command for appropriate action.

SECRET//NOFORN//X1

SECRET//NOFORN//X1

SUBJECT: (U) AR 15-6 Investigation of the Abu Ghraib Detention Facility and
205th MI Brigade

(2) (U) **Finding: LTC Stephen L. Jordan, Director, Joint Interrogation Debriefing Center.** A preponderance of evidence supports that LTC Jordan did, or failed to do, the following:

- Failed to properly train Soldiers and civilians on the ICRP.
- Failed to take full responsibility for his role as the Director, JIDC.
- Failed to establish the necessary checks and balances to prevent and detect abuses.
- Was derelict in his duties by failing to establish order and enforce proper use of ICRP during the night of 24 November 2003 (IP Roundup) which contributed to a chaotic situation in which detainees were abused.
- Failed to prevent the unauthorized use of dogs and the humiliation of detainees who were kept naked for no acceptable purpose while he was the senior officer-in-charge in the Hard Site.
- Failed to accurately and timely relay critical information to COL Pappas, such as:
 - The incident where a detainee had obtained a weapon.
 - ICRC issues.
- Was deceitful during this, as well as the MG Taguba, investigations. His recollection of facts, statements, and incidents were always recounted to avoid blame or responsibility. His version of events frequently diverged from most others.
- Failed to obey a lawful order to refrain from contacting anyone except his attorney regarding this investigation. He conducted an e-mail campaign soliciting support from others involved in the investigation.

(U) **Recommendation:** This information should be forwarded to LTC Jordan's chain of command for appropriate action.

SECRET//NOFORN//X1

SECRET//NOFORN//X1

SUBJECT: (U) AR 15-6 Investigation of the Abu Ghraib Detention Facility and
205th MI Brigade

(3) (U) **Finding: MAJ David M. Price, Operations Officer, Joint Interrogation and Debriefing Center, 141st MI Battalion.** A preponderance of evidence indicates that MAJ Price did, or failed to do, the following:

- Failed to properly train Soldiers and civilians on the ICRP.
- Failed to understand the breadth of his responsibilities as the JIDC Operations Officer. Failed to effectively assess, plan, and seek command guidance and assistance regarding JIDC operations.
- Failed to intervene when the Interrogation Control Element (ICE) received pressure from Higher Headquarters.
- Failed to plan and implement the necessary checks and balances to prevent and detect abuses.
- Failed to properly review interrogation plans which clearly specified the improper use of nudity and isolation as punishment.

(U) **Recommendation:** This information should be forwarded to MAJ Price's chain of command for appropriate action.

(4) (U) **Finding: MAJ Michael D. Thompson, Deputy Operations Officer, Joint Interrogation and Debriefing Center, 325 MI BN.** A preponderance of evidence supports that MAJ Thompson failed to do the following:

- Failed to properly train Soldiers and civilians on the ICRP.
- Failed to understand the breadth of his responsibilities as the JIDC Deputy Operations Officer. Failed to effectively assess, plan, and seek command guidance and assistance regarding JIDC operations.
- Failed to intervene when the ICE received pressure from Higher Headquarters.
- Failed to plan and implement the necessary checks and balances to prevent and detect abuses.
- Failed to properly review interrogation plans which clearly specified the improper use of nudity and isolation as punishment.

(U) **Recommendation:** This information should be forwarded to MAJ Thompson's chain of command for appropriate action.

SECRET//NOFORN//X1

SECRET//NOFORN//X1

SUBJECT: (U) AR 15-6 Investigation of the Abu Ghraib Detention Facility and
205th MI Brigade

(5) (U) **Finding: CPT Carolyn A. Wood, Officer in Charge, Interrogation Control Element (ICE), Joint Interrogation and Debriefing Center, 519 MI BDE.** A preponderance of evidence supports that CPT Wood failed to do the following:

- Failed to implement the necessary checks and balances to detect and prevent detainee abuse. Given her knowledge of prior abuse in Afghanistan, as well as the reported sexual assault of a female detainee by three 519 MI BN Soldiers working in the ICE, CPT Wood should have been aware of the potential for detainee abuse at Abu Ghraib. As the Officer-in-Charge (OIC) she was in a position to take steps to prevent further abuse. Her failure to do so allowed the abuse by Soldiers and civilians to go undetected and unchecked.
- Failed to assist in gaining control of a chaotic situation during the IP Roundup, even after SGT Eckroth approached her for help.
- Failed to provide proper supervision. Should have been more alert due to the following incidents:
 - An ongoing investigation on the 519 MI BN in Afghanistan.
 - Prior reports of 519 MI BN interrogators conducting unauthorized interrogations.
 - SOLDIER29's reported use of nudity and humiliation techniques.
 - Quick Reaction Force (QRF) allegations of detainee abuse by 519th MI Soldiers.
- Failed to properly review interrogation plans which clearly specified the improper use of nudity and isolation in interrogations and as punishment.
- Failed to ensure that Soldiers were properly trained on interrogation techniques and operations.
- Failed to adequately train Soldiers and civilians on the ICRP.

(U) **Recommendation:** This information should be forwarded to CPT Wood's chain of command for appropriate action.

(6) (U) **Finding: SOLDIER-28, Guantanamo Base Team Chief, 260th MI Battalion.** A preponderance of evidence supports that SOLDIER28 did, or failed to do, the following:

- Failed to report detainee abuse when he was notified by SOLDIER-11 that a detainee was observed in a cell naked, hooded, and whimpering, and when SOLDIER-11 reported an interrogator made a detainee pull his jumpsuit down to his waist.

(U) **Recommendation:** This information should be forwarded to SOLDIER-28's chain of command for appropriate action.

(7) (U) **Finding: SOLDIER-23, Operations Section, ICE, JIDC, 325 MI BN.** A preponderance of evidence supports that SOLDIER23 did, or failed to do, the following:

SECRET//NOFORN//X1

SECRET//NOFORN//X1

SUBJECT: (U) AR 15-6 Investigation of the Abu Ghraib Detention Facility and
205th MI Brigade

- Failed to prevent detainee abuse and permitted the unauthorized use of dogs and unauthorized interrogations during the IP Roundup. As the second senior MI officer during the IP Roundup, his lack of leadership contributed to detainee abuse and the chaotic situation during the IP Roundup.
- Failed to properly supervise and ensure Soldiers and civilians followed the ICRP.
- Failed to properly review interrogation plans which clearly specified the improper use of nudity and isolation as interrogation techniques and punishment.

(U) **Recommendation:** This information should be forwarded to SOLDIER23's chain of command for appropriate action.

(8) (U) **Finding:** SOLDIER-14, Night Shift OIC, ICE, JIDC, 519 MI BN. A preponderance of evidence supports that SOLDIER-14 did, or failed to do, the following:

- Failed to properly supervise and ensure Soldiers and civilians followed the ICRP.
- Failed to provide proper supervision. SOLDIER-14 should have been aware of the potential for detainee abuse at Abu Ghraib. The following incidents should have increased his diligence in overseeing operations:
 - An ongoing investigation of the 519 MI BN in Afghanistan.
 - Allegations by a female detainee that 519 MI BN interrogators sexually assaulted her. The Soldiers received non-judicial punishment for conducting unauthorized interrogations.
 - SOLDIER-29's reported use of nudity and humiliation techniques.
 - Quick Reaction Force (QRF) allegations of detainee abuse by 519 MI BN Soldiers.
- Failed to properly review interrogation plans which clearly specified the improper use of nudity and isolation as punishment.

(U) **Recommendation:** This information should be forwarded to SOLDIER-14's chain of command for appropriate action.

SECRET//NOFORN//X1

SECRET//NOFORN//X4

SUBJECT: (U) AR 15-6 Investigation of the Abu Ghraib Detention Facility and
205th MI Brigade

(9) (U) **Finding: SOLDIER-15, Interrogator, 66 MI GP.** A preponderance of evidence supports that SOLDIER15 did, or failed to do, the following:

- Failed to report detainee abuse. He witnessed SSG Frederick twisting the handcuffs of a detainee causing pain and covering the detainee's nose and mouth to restrict him from breathing.
 - Witnessed during that same incident, CIVILIAN-11 threaten a detainee by suggesting he would be turned over to SSG Frederick for further abuse if he did not cooperate.

(U) **Recommendation:** This information should be forwarded to SOLDIER-15's chain of command for appropriate action.

(10) (U) **Finding: SOLDIER-22, 302d MI Battalion.** A preponderance of evidence supports that SOLDIER22 did, or failed to do, the following:

- Failed to report detainee abuse.
 - He was made aware by SOLDIER-25 of an incident where three detainees were abused by MPs (Reference Annex I, Appendix 1, Photographs M36-37, M39-41).
 - He was made aware by SOLDIER-25 of the use of dogs to scare detainees.
 - He overheard Soldiers stating that MPs were using detainees as "practice dummies;" striking their necks and knocking them unconscious.
 - He was made aware of MPs conducting "PT" (Physical Training) sessions with detainees and MI personnel participating:
- Failed to obey a direct order. He interfered with this investigation by talking about the investigation, giving interviews to the media, and passing the questions being asked by investigators to others via a website.

(U) **Recommendation:** This information should be forwarded to SOLDIER-22's chain of command for appropriate action.

SECRET//NOFORN//X4

SECRET//NOFORN//X1

SUBJECT: (U) AR 15-6 Investigation of the Abu Ghraib Detention Facility and
205th MI Brigade

(11) (U) **Finding: SOLDIER-10, Analyst, 325 MI BN (currently attached to HHC, 504 MIBDE)**. A preponderance of evidence supports that SOLDIER10 did, or failed to do, the following:

- Actively participated in abuse when he threw water on three detainees who were handcuffed together and made to lie on the floor of the detention facility (Reference Annex I, Appendix 1, Photographs M36-37).
- Failed to stop detainee abuse in the above incident and in the incident when SOLDIER-29 stripped a detainee of his clothes and walked the detainee naked from an interrogation booth to Camp Vigilant during a cold winter day.
- Failed to report detainee abuse.

(U) **Recommendation:** This information should be forwarded to SOLDIER-10's chain of command for appropriate action.

(12) (U) **Finding: SOLDIER-17, Interrogator, 2d MI Battalion**. A preponderance of evidence supports that SOLDIER17 did, or failed to do, the following:

- Failed to report the improper use of dogs. He saw an un-muzzled black dog go into a cell and scare two juvenile detainees. The dog handler allowed the dogs to "go nuts" on the juveniles (Reference Annex I, Appendix 1, Photograph D-48).
- Failed to report inappropriate actions of dog handlers. He overheard Dog Handlers state they had a competition to scare detainees to the point they would defecate. They claimed to have already made several detainees urinate when threatened by their dogs.

(U) **Recommendation:** This information should be forwarded to SOLDIER-17's chain of command for appropriate action.

SECRET//NOFORN//X1

SECRET//NOFORN//X1

SUBJECT: (U) AR 15-6 Investigation of the Abu Ghraib Detention Facility and
205th MI Brigade

(13) (U) **Finding: SOLDIER-19, Interrogator, 325 MI BN.** A preponderance of evidence supports that SOLDIER-19 did, or failed to do, the following:

- Abused detainees:
 - Actively participated in the abuse of three detainees depicted in photographs (Reference Annex I, Appendix 1, Photographs M36-37, M39-41). He threw a Foam-ball at their genitals and poured water on the detainees while they were bound, nude, and abused by others.
 - Turned over a detainee to the MPs with apparent instructions for his abuse. He returned to find the detainee naked and hooded on the floor whimpering.
 - Used improper interrogation techniques. He made a detainee roll down his jumpsuit and threatened the detainee with complete nudity if he did not cooperate.
- Failed to stop detainee abuse in the above incidents.
- Failed to report detainee abuse for above incidents.

(U) **Recommendation:** This information should be forwarded to SOLDIER-19's chain of command for appropriate action.

(14) (U) **Findings: SOLDIER-24, Analyst, 325 MI BN (currently attached to HHC, 504 MI BDE).** A preponderance of evidence supports that SOLDIER24 did, or failed to do, the following:

- Failed to report detainee abuse. He was present during the abuse of detainees depicted in photographs (Reference Annex I, Appendix 1, Photographs M36-37, M39, M41).
- Failed to stop detainee abuse.

(U) **Recommendation:** This information should be forwarded to SOLDIER-24's chain of command for appropriate action.

SECRET//NOFORN//X1

SECRET//NOFORN//X1

SUBJECT: (U) AR 15-6 Investigation of the Abu Ghraib Detention Facility and
205th MI Brigade

(15) (U) **Findings: SOLDIER-25, Interrogator, 321st MI BN.** A preponderance of evidence supports that SOLDIER25 did, or failed to do, the following:

- Failed to report detainee abuse.
 - She saw Dog Handlers use dogs to scare detainees. She “thought it was funny” as the detainees would run into their cells from the dogs.
 - She was told by SOLDIER-24 that the detainees who allegedly had raped another detainee were handcuffed together, naked, in contorted positions, making it look like they were having sex with each other.
 - She was told that MPs made the detainees wear women’s underwear.
- Failed to stop detainee abuse.

(U) **Recommendation:** This information should be forwarded to SOLDIER-25's chain of command for appropriate action.

(16) (U) **Finding: SOLDIER-29, Interrogator, 66 MI GP.** A preponderance of evidence supports that SOLDIER29 did, or failed to do, the following:

- Failed to report detainee abuse.
 - She saw CPL Graner slap a detainee.
 - She saw a computer screen saver depicting naked detainees in a “human pyramid.”
 - She was aware MPs were taking photos of detainees.
 - She knew MPs had given a detainee a cold shower, made him roll in the dirt, and stand outside in the cold until he was dry. The detainee was then given another cold shower.
- Detainee abuse (Humiliation). She violated interrogation rules of engagement by stripping a detainee of his clothes and walking him naked from an interrogation booth to Camp Vigilant on a cold winter night.
- Gave MPs instruction to mistreat/abuse detainees.
 - SOLDIER2-9's telling MPs (SSG Frederick) when detainees had not cooperated in an interrogation appeared to result in subsequent abuse.
 - One of the detainees she interrogated was placed in isolation for several days and allegedly abused by the MPs. She annotated in an interrogation report (IN-AG00992-DETAINEE-08-04) that a “direct approach” was used with “the reminder of the unpleasantness that occurred the last time he lied to us.”

(U) **Recommendation:** This information should be forwarded to SOLDIER-29's chain of command for appropriate action.

SECRET//NOFORN//X1

SECRET//NOFORN//X1

SUBJECT: (U) AR 15-6 Investigation of the Abu Ghraib Detention Facility and
205th MI Brigade

(17) (U) Findings: **SOLDIER-08, Dog Handler, Abu Ghraib, 42 MP Detachment, 16 MP BDE (ABN)**. A preponderance of evidence supports that SOLDIER08 did, or failed to do, the following:

- Inappropriate use of dogs. Photographs (Reference Annex I, Appendix 1, D46, D52, M149-151) depict SOLDIER-08 inappropriately using his dog to terrorize detainees.
- Abused detainees. SOLDIER-08 had an on-going contest with SOLDIER-27, another dog handler, to scare detainees with their dogs in order to see who could make the detainees urinate and defecate first.

(U) **Recommendation:** This information should be forwarded to SOLDIER-08's chain of command for appropriate action.

(18) (U) Findings: **SOLDIER34, 372 MP CO.** A preponderance of evidence supports that SOLDIER34 did, or failed to do, the following:

- Failed to report detainee abuse. He was present during the abuse of detainees depicted in photographs (Reference Annex I, Appendix 1, Photographs M36-37, M39-41).
- Failed to stop detainee abuse.

(U) **Recommendation:** This information should be forwarded to SOLDIER34's chain of command for appropriate action.

(19) (U) Findings: **SOLDIER-27, 372 MP CO.** A preponderance of evidence supports that SOLDIER27 did, or failed to do, the following:

- Actively participated in detainee abuse.
 - During the medical treatment (stitching) of a detainee, he stepped on the chest of the detainee (Reference Annex I, Appendix 1, Photograph M163).
 - He participated in the abuse of naked detainees depicted in photographs (Reference Annex I, Appendix I, Photographs M36-37, M39-41).
- Failed to stop detainee abuse.

(U) **Recommendation:** This information should be forwarded to SOLDIER27's chain of command for appropriate action.

SECRET//NOFORN//X1

SECRET//NOFORN//X1

SUBJECT: (U) AR 15-6 Investigation of the Abu Ghraib Detention Facility and
205th MI Brigade

(20) (U) **Findings: SOLDIER-27, Dog Handler, Abu Ghraib, 523 MP Detachment.** A preponderance of evidence supports that SOLDIER27 did, or failed to do, the following:

- Inappropriate use of dogs. Photographs (Reference Annex I, Appendix 1, Photographs D46, D48, M148, M150, M151, M153, Z1, Z3-6) depict SOLDIER-27 inappropriately using his dog terrorizing detainees.
- Detainee abuse. SOLDIER-27 had an on-going contest with SOLDIER-08, another dog handler, to scare detainees with their dogs and cause the detainees to urinate and defecate.
- Led his dog into a cell with two juvenile detainees and let his dog go "nuts." The two juveniles were yelling and screaming with the youngest one hiding behind the oldest.

(U) **Recommendation:** This information should be forwarded to SOLDIER-27's chain of command for appropriate action.

(21) (U) **Finding: SOLDIER-20, Medic, 372 MP CO.** A preponderance of evidence supports that SOLDIER20 did, or failed to do, the following:

- Failed to report detainee abuse.
 - When called to assist a detainee who had been shot in the leg, he witnessed CPL Graner hit the detainee in his injured leg with a stick.
 - He saw the same detainee handcuffed to a bed over several days, causing great pain to the detainee as he was forced to stand.
 - He saw the same detainee handcuffed to a bed which resulted in a dislocated shoulder.
 - He saw pictures of detainees being abused (stacked naked in a "human pyramid").

(U) **Recommendation:** This information should be forwarded to SOLDIER-20's chain of command for appropriate action.

(22) (U) **Finding: SOLDIER-01, Medic, Abu Ghraib.** A preponderance of evidence supports that SOLDIER01 did, or failed to do, the following:

- Failed to report detainee abuse. She saw a "human pyramid" of naked Iraqi prisoners, all with sandbags on their heads when called to the Hard Site to provide medical treatment.

(U) **Recommendation:** This information should be forwarded to SOLDIER-01's chain of command for appropriate action.

(23) (U) **Finding: CIVILIAN-05, CACI employee.** A preponderance of evidence supports that CIVILIAN-05 did, or failed to do, the following:

SECRET//NOFORN//X1

SECRET//NOFORN//X1

SUBJECT: (U) AR 15-6 Investigation of the Abu Ghraib Detention Facility and
205th MI Brigade

- He grabbed a detainee (who was handcuffed) off a vehicle and dropped him to the ground. He then dragged him into an interrogation booth and as the detainee tried to get up, CIVILIAN-05 would yank the detainee very hard and make him fall again.
- Disobeyed General Order Number One; drinking alcohol while at Abu Ghraib.
- Refused to take instructions from a Tiger Team leader and refused to take instructions from military trainers.
 - When confronted by SSG Neal, his Tiger Team leader, about his inadequate interrogation techniques, he replied, "I have been doing this for 20 years and I do not need a 20 year old telling me how to do my job."
 - When placed in a remedial report writing class because of his poor writing, he did not pay attention to the trainer and sat in the back of the room facing away from the trainer.

(U) **Recommendation:** This information should be forwarded to the Army General Counsel for determination of whether CIVILIAN-05 should be referred to the Department of Justice for prosecution. This information should be forwarded to the Contracting Officer (KO) for appropriate contractual action.

(24) (U) **Finding:** CIVILIAN-10, Translator, Titan employee. After a thorough investigation, we found no direct involvement in detainee abuse by CIVILIAN-10. Our investigation revealed CIVILIAN-10 had a valid security clearance until it was suspended.

(U) **Recommendation:** This information should be forwarded to Titan via the KO. CIVILIAN-10 is cleared of any wrong doing and should retain his security clearance.

SECRET//NOFORN//X1

SECRET//NOFORN//X1

SUBJECT: (U) AR 15-6 Investigation of the Abu Ghraib Detention Facility and
205th MI Brigade

(25) (U) **Finding: CIVILIAN-11, Interrogator, CACI employee.** A preponderance of evidence supports that CIVILIAN11 did, or failed to do, the following:

- Detainee abuse.
 - He encouraged SSG Frederick to abuse Iraqi Police detained following a shooting incident (IP Roundup). SSG Frederick twisted the handcuffs of a detainee being interrogated; causing pain.
 - He failed to prevent SSG Frederick from covering the detainee's mouth and nose restricting the detainee from breathing:
- Threatened the Iraqi Police "with SSG Frederick." He told the Iraqi Police to answer his questions or he would bring SSG Frederick back into the cell.
- Used dogs during the IP Roundup in an unauthorized manner. He told a detainee, "You see that dog there, if you do not tell me what I want to know, I'm going to get that dog on you."
- Placed a detainee in an unauthorized stress position (Reference Annex I, Appendix 2, Photograph "Stress Positions"). CIVILIAN-11 is photographed facing a detainee who is in a stress position on a chair with his back exposed. The detainee is in a dangerous position where he might fall back and injure himself.
- Failed to prevent a detainee from being photographed.

(U) **Recommendation:** This information should be forwarded to the Army General Counsel for determination of whether CIVILIAN-11 should be referred to the Department of Justice for prosecution. This information should be forwarded to the KO for appropriate contractual action.

SECRET//NOFORN//X1

SECRET//NOFORN//X1

SUBJECT: (U) AR 15-6 Investigation of the Abu Ghraib Detention Facility and
205th MI Brigade

(26) (U) **Finding: CIVILIAN-16, Translator, Titan employee.** A preponderance of evidence supports that CIVILIAN-16 did, or failed to do, the following:

- Failed to report detainee abuse.
 - She participated in an interrogation during the IP Roundup, where a dog was brought into a cell in violation of approved ICRP.
 - She participated in the interrogation of an Iraqi Policeman who was placed in a stress position; squatting backwards on a plastic lawn chair. Any sudden movement by the IP could have resulted in injury (Reference Annex I, Appendix 2, Photograph "Stress Positions").
 - She was present during an interrogation when SSG Frederick twisted the handcuffs of a detainee, causing the detainee pain.
 - She was present when SSG Frederick covered an IP's mouth and nose, restricting the detainee from breathing.
- Failed to report threats against detainees.
 - She was present when CIVILIAN-11 told a detainee, "You see that dog there, if you do not tell me what I want to know, I'm going to get that dog on you."
 - She was present when CIVILIAN-11 threatened a detainee "with SSG Frederick."

(U) **Recommendation:** This information should be forwarded to the Army General Counsel for determination of whether CIVILIAN-16 should be referred to the Department of Justice for prosecution. This information should be forwarded to the KO for appropriate contractual action.

(27) (U) **Finding: CIVILIAN-17, Interpreter, Titan employee.** A preponderance of evidence supports that CIVILIAN-17 did, or failed to do, the following:

- Actively participated in detainee abuse.
 - He was present during the abuse of detainees depicted in photographs (Reference Annex I, Appendix 1, Photographs M36-37, M39, M41).
 - A detainee claimed that CIVILIAN-17 (sic), an interpreter, hit him and cut his ear which required stitches.
 - Another detainee claimed that someone fitting CIVILIAN-17's description raped a young detainee.
- Failure to report detainee abuse.
- Failure to stop detainee abuse.

(U) **Recommendation:** This information should be forwarded to the Army General Counsel for determination of whether CIVILIAN-17 should be referred to the Department of Justice for prosecution. This information should be forwarded to the KO for appropriate contractual action.

SECRET//NOFORN//X1

SECRET//NOFORN//X1

SUBJECT: (U) AR 15-6 Investigation of the Abu Ghraib Detention Facility and
205th MI Brigade

(28) (U) **Finding:** CIVILIAN-21, Interrogator, CACI employee. A preponderance of evidence supports that CIVILIAN-21 did, or failed to do, the following:

- Inappropriate use of dogs. SOLDIER-26 stated that CIVILIAN-21 used a dog during an interrogation and the dog was unmuzzled. SOLDIER-25 stated she once saw CIVILIAN21 standing on the second floor of the Hard Site, looking down to where a dog was being used against a detainee, and yelling to the MPs "Take him home." The dog had torn the detainee's mattress. He also used a dog during an interrogation with SSG Aston but stated he never used dogs.
- Detainee abuse. CPT Reese stated he saw "NAME" (his description of "NAME"" matched CIVILIAN-21) push (kick) a detainee into a cell with his foot.
- Making false statements. During questioning about the use of dogs in interrogations, CIVILIAN21 stated he never used them.
- Failed to report detainee abuse. During an interrogation, a detainee told SOLDIER-25 and CIVILIAN-21 that CIVILIAN-17, an interpreter, hit him and cut his ear which required stitches. SOLDIER-25 stated she told CIVILIAN-21 to annotate this on the interrogation report. He did not report it to appropriate authorities.
- Detainee Humiliation.
 - CIVILIAN-15 stated he heard CIVILIAN-21 tell several people that he had shaved the hair and beard of a detainee and put him in red women's underwear. CIVILIAN-21 was allegedly bragging about it.
 - CIVILIAN-19 stated he heard OTHER AGENCY EMPLOYEE02 laughing about red panties on detainees.

(U) **Recommendation:** This information should be forwarded to the Army General Counsel for determination of whether CIVILIAN-21 should be referred to the Department of Justice for prosecution. This information should be forwarded to the KO for appropriate contractual action.

SECRET//NOFORN//X1

SECRET//NOFORN//X1

SUBJECT: (U) AR 15-6 Investigation of the Abu Ghraib Detention Facility and
205th MI Brigade

(29) (U) **Finding:** There were several personnel who used clothing removal, improper isolation, or dogs as techniques for interrogations in violation of the Geneva Conventions. Several interrogators documented these techniques in their interrogation plans and stated they received approval from the JIDC, Interrogation Control Element. The investigative team found several entries in interrogation reports which clearly specified clothing removal; however, all personnel having the authority to approve interrogation plans claim they never approved or were aware of clothing removal being used in interrogations. Also found were interrogation reports specifying use of isolation, "the Hole." While the Commander, CJTF-7 approved "segregation" on 25 occasions, this use of isolation sometimes trended toward abuse based on sensory deprivation and inhumane conditions. Dogs were never approved, however on several occasions personnel thought they were. Personnel who committed abuse based on confusion regarding approvals or policies are in need of additional training.

(U) **Recommendation:** This information should be forwarded to the Soldiers' chain of command for appropriate action.

CIVILIAN-14 (formally with 368 Military Intelligence Battalion)
SOLDIER-04, 500 Military Intelligence Group
SOLDIER-05, 500 Military Intelligence Group
SOLDIER-03, GTMO Team, 184 Military Intelligence Company
SOLDIER-13, 66 Military Intelligence Group
SOLDIER-18, 66 Military Intelligence Group
SOLDIER-02, 66 Military Intelligence Group
SOLDIER-11 6 Battalion 98 Division (IT)
SOLDIER-16, 325 Military Intelligence Battalion
SOLDIER-30, 325 Military Intelligence Battalion
SOLDIER-26, 320 Military Police Battalion
SOLDIER-06, 302 Military Intelligence Battalion
SOLDIER-07, 325 Military Intelligence Battalion
SOLDIER-21, 325 Military Intelligence Battalion
SOLDIER-09, 302 Military Intelligence Battalion
SOLDIER-12, 302 Military Intelligence Battalion
CIVILIAN-20, CACI Employee

SECRET//NOFORN//X1

SECRET//NOFORN//X1

SUBJECT: (U) AR 15-6 Investigation of the Abu Ghraib Detention Facility and
205th MI Brigade

(30) (U) **Finding:** In addition to SOLDIER-20 and SOLDIER01, medical personnel may have been aware of detainee abuse at Abu Ghraib and failed to report it. The scope of this investigation was MI personnel involvement. SOLDIER-20 and SOLDIER-01 were cited because sufficient evidence existed within the scope of this investigation to establish that they were aware of detainee abuse and failed to report it. Medical records were requested, but not obtained, by this investigation. The location of the records at the time this request was made was unknown.

(U) **Recommendation:** An inquiry should be conducted into 1) whether appropriate medical records were maintained, and if so, were they properly stored and collected and 2) whether medical personnel were aware of detainee abuse and failed to properly document and report the abuse.

(31) (U) **Finding:** A preponderance of the evidence supports that SOLDIER-31, SOLDIER-32, and SOLDIER-33 participated in the alleged sexual assault of a female detainee by forcibly kissing her and removing her shirt (Reference CID Case-0216-03-CID259-6121). The individuals received non-judicial punishment for conducting an unauthorized interrogation, but were not punished for the alleged sexual assault.

(U) **Recommendation:** CID should review case # 0216-03-CID259-61211 to determine if further investigation is appropriate. The case should then be forwarded to the Soldiers' chain of command for appropriate action.

(32) (U) **Finding:** An unidentified person, believed to be a contractor interpreter, was depicted in six photographs taken on 25 October 2003 showing the abuse of three detainees. The detainees were nude and handcuffed together on the floor. This investigation could not confirm the identity of this person; however, potential leads have been passed to and are currently being pursued by CID.

(U) **Recommendation:** CID should continue to aggressively pursue all available leads to identify this person and determine the degree of his involvement in detainee abuse.

SECRET//NOFORN//X1

1285

SECRET//NOFORN//X1

SUBJECT: (U) AR 15-6 Investigation of the Abu Ghraib Detention Facility and
205th MI Brigade

7. (U) Personnel Listing. Deleted in accordance with the Privacy Act and 10 USC §130b

SECRET//NOFORN//X1

137

SECRET//NOFORN//X1

SUBJECT: (U) AR 15-6 Investigation of the Abu Ghraib Detention Facility and
205th MI Brigade

8. (U) Task Force Members.

LTG Anthony R. CIVILIAN08 Command	Investigating Officer	HQs, Training and Doctrine
MG George R. Fay	Investigating Officer	HQs, Dept of the Army, G2
Mr. Thomas A. Gandy	Deputy	HQs, Dept of the Army, G2
LTC Phillip H. Bender	Chief Investigator	HQs, Dept of the Army, G2
LTC Michael Benjamin	Legal Advisor	TJAG
MAJ(P) Maricela Alvarado	Executive Officer	HQs, Dept of the Army, G2
CPT Roseanne M. Bleam	Staff Judge Advocate, CJTF-7	CJTF-7 (MNF-I) SJA
CW5 Donald Marquis	SME – Training & Doctrine	HQs, US Army Intelligence Center
CW3 Brent Pack	CID Liaison	US Army CID Command
CW2 Mark Engan	Investigator – Baghdad Team	HQs, 308 th MI Bn, 902 nd MI Group
SGT Patrick D. Devine	All Source Analyst	ACIC, 310 th MI Bn, 902 nd MI Group
CPL Ryan Hausterman	Investigator – Baghdad Team	HQs, 310 th MI Bn, 902 nd MI Group
Mr. Maurice J. Sheley	Investigator	HQs, US Army INSCOM
Mr. Michael P. Scanland	Investigator	HQs, 902 nd MI Group
Mr. Claude B. Benner	Investigative Review	ACIC, 902 nd MI Group
Mr. Michael Wright	Investigator	HQs, 308 th MI Bn, 902 nd MI Group
Mr. Scott Robertson	Investigator	HQs, Dept of the Army, G2
Mr. Paul Stark	Chief of Analysis	ACIC, 310 th MI Bn, 902 nd MI Group
Mr. Kevin Brueie	Investigator – Baghdad Team	Det 13, FCA, 902 nd MI Group
Ms. Linda Flanigan	Analyst	ACIC, 310 th MI Bn, 902 nd MI Group
Mr. Albert Scott	Cyber-Forensic Analyst	HQs, 310 th MI Bn, 902 nd MI Group
Ms. Saoirse Spain	Analyst	ACIC, 310 th MI Bn, 902 nd MI group
Mr. Albert J. McCam Jr.	Chief of Logistics	HQs, Dept of the Army, G2
Ms. Cheryl Clowser	Administrator	HQs, Dept of the Army, G2
Mr. Alfred Moreau	SME – Contract Law	HQs, Dept of the Army, OTJAG
Mr. Rudolph Garcia	Senior Editor	HQs, Dept of the Army, G2

Contract Services provided by Object Sciences Corp. and SYTEX

SECRET//NOFORN//X1

SECRET//NOFORN//X1

SUBJECT: (U) AR 15-6 Investigation of the Abu Ghraib Detention Facility and
205th MI Brigade

9. (U) Acronyms.

2 MI BN	2d Military Intelligence Battalion
B/321 MI BN	B Company, 321st Military Intelligence Battalion
B/325 MI BN	B Company, 325th Military Intelligence Battalion
A/205 MI BN	A Company, 205th Military Intelligence Battalion
115 MP BN	115th Military Police Battalion
165 MI BN	165th Military Intelligence Battalion
205 MI BDE	205th Military Intelligence Brigade
229 MP CO	229th Military Police Battalion
320 MP BN	320th Military Police Battalion
320 MP CO	320th Military Police Company
323 MI BN	323d Military Intelligence Battalion
325 MI BN	325th Military Intelligence Battalion
372 MP CO	372d Military Police Company
377 TSC	377th Theater Support Command
400 MP BN	400th Military Police Battalion
470 MI GP	470th Military Intelligence Group
447 MP CO	447th Military Police Company
500 MI GP	500th Military Intelligence Group
504 MI BDE	504th Military Intelligence Battalion
519 MI BN	519th Military Intelligence Battalion
66 MI GP	66th Military Intelligence Group
670 MP CO	670th Military Police Company
72 MP CO	72d Military Police Company
800 MP BDE	800th Military Police Brigade
870 MP CO	870th Military Police Company
1SG	First Sergeant
A/519 MI BN	A Company, 519th Military Intelligence Battalion
AAR	After Action Report
AFJI	Air Force Joint Instructor
AG	Abu Ghraib
ANCOC	Advanced Non-Commission Officer's Course
AR	Army Regulation
ATSD (IO)	Assistant to the Secretary of Defense for Intelligence Oversight
BDE	Brigade
BG	Brigadier General
BIAP	Baghdad International Airport
BN	Battalion
BNCOC	Basic Non-Commission Officer's Course
BPA	Blanket Purchase Agreement
C2X	Command and Control Exercise

SECRET//NOFORN//X1

1288

SECRET//NOFORN//X1

SUBJECT: (U) AR 15-6 Investigation of the Abu Ghraib Detention Facility and
205th MI Brigade

CALL	Center for Army Lessons Learned
CENTCOM	US Central Command
CG	Commanding General
CHA	Corps Holding Area
CIA	Central Intelligence Agency
CID	Criminal Investigation Command
CJCS-I	Chairman, Joint Chief of Staff Instruction
CJTF-7	Combined Joint Task Force 7
CM&D	Collection Management and Dissemination
COL	Colonel
COR	Contracting Officers Representative
CP	Collection Point
CPA	Coalition Provisional Authority
CPL	Corporal
CPT	Captain
CSH	Combat Support Hospital
DA	Department of the Army
DAIG	Department of the Army Inspector General
DCI	Director of Central Intelligence
DCG	Deputy Commanding General
DIAM	Defense Intelligence Agency Manual
DoD	Department of Defense
1LT	First Lieutenant
CASH	Combat Army Surgical Hospital
DIA	Defense Intelligence Agency
KO	Contracting Officer
DOJ	Department of Justice
DRA	Detention Review Authority
DRB	Detainee Release Branch
EPW	Enemy Prisoner of War
FM	Field Manual
FOB	Forward Operating Base
FRAGO	Fragmentary Order
G-3	Army Training Division
GCIV	Geneva Conventions IV
GP	Group
GSA	General Services Administration
GTMO	Guantanamo Naval Base, Cuba
GWOT	Global War On Terrorism
HQ	Headquarters
HUMINT	Human Intelligence
IAW	In Accordance With
ICE	Interrogation and Control Element
ICRC	International Committee of the Red Cross

SECRET//NOFORN//X1

140

SECRET//NOFORN//X1

SUBJECT: (U) AR 15-6 Investigation of the Abu Ghraib Detention Facility and
205th MI Brigade

ICRP	Interrogation and Counter-Resistance Policies
IET	Initial Entry Training
ID	Infantry Division
IG	Inspector General
IMINT	Imagery Intelligence
INSCOM	Intelligence and Security Command
IP	Iraqi Police
IR	Interment/Resettlement
IROE	Interrogation Rules Of Engagement
ISCT	Interrogation Support to Counterterrorism
ISG	Iraqi Survey Group
JA	Judge Advocate
JCS	Joint Chiefs of Staff
JIDC	Joint Interrogation and Detention Center
JTF-GTMO	Joint Task Force Guantanamo
MAJ	Major
MCO	Marine Corps Order
LTC	Lieutenant Colonel
LTG	Lieutenant General
MFR	Memorandum For Record
MG	Major General
MI	Military Intelligence
MIT	Mobile Interrogation Team
MOS	Military Occupational Specialty
MOU	Memorandum of Understanding
MP	Military Police
MRE	Meals Ready to Eat
MSC	Major Subordinate Command
MSG	Master Sergeant
MTT	Mobile Training Team
NCO	Non-Commissioned Officer
NCOIC	Non-Commissioned Officer In Charge
OER	Officer Evaluation Report
OGA	Other Government Agency
OGC	Office Of General Counsel
OIC	Officer In Charge
OIF	Operation Iraqi Freedom
OPORD	Operations Order
OPNAVINST	Office of the Chief of Naval Operations Instructions
OSJA	Office Of the Staff Judge Advocate
OVB	Operation Victory Bounty
RP	Retained Personnel
SASO	Stability And Support Operations
SECARMY	Secretary of the Army

SECRET//NOFORN//X1

1290

SECRET//NOFORN//X1

SUBJECT: (U) AR 15-6 Investigation of the Abu Ghraib Detention Facility and
205th MI Brigade

SECDEF	Secretary of Defense
SFC	Sergeant First Class
SGT	Sergeant
SIGINT	Signals Intelligence
SITREP	Situation Report
HMMWV	High-Mobility, Multipurpose Wheeled Vehicle
PFC	Private First Class
MA1	Master at Arms 1
MA2	Master at Arms 2
PVT	Private
QRF	Quick Reaction Force
SJA	Staff Judge Advocate
SOF	Special Operations Forces
SOP	Standard Operating Procedure
SOUTHCOM	US Southern Command
SOW	Statement of Work
SSG	Staff Sergeant
TACON	Tactical Control
THT	Tactical HUMINT Team
TRADOC	Training and Doctrine Command
TTP	Tactics, Techniques, and Procedures
UCMJ	Uniform Code Of Military Justice
USAIC	US Army Intelligence Center
USAR	US Army Reserve
VFR	Visual Flight Rules
E-6	Enlisted Grade 6 (Staff Sergeant)
E-7	Enlisted Grade 7 (Sergeant First Class)
E-5	Enlisted Grade 5 (Sergeant)
96B	Intelligence Analyst
NBC	National Business Center
FSS	Federal Supply Schedule
POC	Point of Contact
DAIG	Department of the Army Inspector General
97E	Human Intelligence Collector
351E	Interrogation Warrant Officer
FBI	Federal Bureau of Investigation
ISN	Internee Serial Number
JTF-21	Joint Task Force – 21
TF-121	Task Force – 121
SEAL	Sea, Air, Land
SPC	Specialist
RFF	Request for Forces
TF-20	Task Force – 20
97B	Counterintelligence Agent

SECRET//NOFORN//X1

142

1291

SECRET//NOFORN//X1

SUBJECT: (U) AR 15-6 Investigation of the Abu Ghraib Detention Facility and
205th MI Brigade

CM&D	Collection, Management and Dissemination
JIG	Joint Intelligence Group
351B	Counterintelligence Warrant Officer
PT	Physical Training
IRF	Internal Reaction Force

SECRET//NOFORN//X1

143

[Questions for the record with answers supplied follow:]

QUESTIONS SUBMITTED BY SENATOR SUSAN COLLINS

CHAIN OF COMMAND

1. Senator COLLINS. General Taguba, did you see any indication that the initial reports of abuse at Abu Ghraib prison were not taken seriously by investigators of the Department of Defense (DOD) chain of command?

General TAGUBA. The CG, Combined Joint Task Force-7 (CJTF-7), immediately directed an investigation by the Army Criminal Investigation Division into the allegations of prisoner abuse at Abu Ghraib upon being notified of the allegations on or about 16 Jan 04. Subsequently, Lieutenant General Sanchez requested Commander, Central Command (CENTCOM) for a two-star general officer to conduct an investigation into the allegations. On 24 Jan 04, I was initially notified of my appointment to conduct the investigation under the provisions of AR 15-6. The formal appointment was signed by Lieutenant General McKiernan, CG, Combined Forces Land Component Command (CFLCC) on 31 Jan 04. I found no evidence that any investigators or members of the chain of command at CJTF-7 or above did not take the allegations seriously.

2. Senator COLLINS. General Kern, who in General Sanchez's chain of command reported directly to him regarding detention and interrogation operations?

General KERN. The Deputy Commanding General, Major General Wojdakowski, and the CJTF-7 Staff reported directly to Lieutenant General Sanchez. General Karpinski and Colonel Pappas reported to the Deputy Commander rather than to General Sanchez directly.

3. Senator COLLINS. General Kern, did General Karpinski ever directly brief General Sanchez?

General KERN. Yes, Brigadier General Karpinski briefed General Sanchez on several occasions.

4. Senator COLLINS. General Kern, did Colonel Pappas report to General Karpinski, or up through a separate intelligence chain of command?

General KERN. Both were separate brigade commanders and reported separately through different channels of the CJTF-7 chain of command.

USE OF DOGS

5. Senator COLLINS. General Fay, was there any link of using dogs in Afghanistan and Iraq?

General FAY. We are unaware of any evidence to suggest that dogs were used during interrogations in Afghanistan. Therefore, we do not believe there was a link.

6. Senator COLLINS. General Fay, who conceived the idea of using dogs as an interrogation technique?

General FAY. We do not know who originally conceived the idea to use dogs during interrogations at Abu Ghraib. We do know that Major General Geoffrey Miller spoke to Colonel Thomas Pappas and others when Major General Miller made his visit to Iraq in late August early September 2003 about the use of dogs. Major General Miller suggested that dogs be used for security and control purposes as they are used at Guantanamo (GTMO). Pappas asserts that he perceived that Major General Miller was suggesting that dogs be used during interrogations. When Colonel Pappas later authorized the use of dogs during interrogations he believed he was following Major General Miller's suggestion.

QUESTIONS SUBMITTED BY SENATOR CARL LEVIN

WHITE HOUSE MEMO

7. Senator LEVIN. General Fay, on February 7, 2002, the President determined that the Geneva Conventions did not apply to the conflict with al Qaeda, and that detainees were to be treated consistent with the principles of the Convention only "to the extent appropriate and consistent with military necessity." The Schlesinger Panel Report (p. 10) states that when General Sanchez approved interrogation techniques that included a dozen techniques beyond those authorized by Field Manual

(FM) 34–52 and five beyond those approved for Guantanamo, he used “reasoning from the President’s Memorandum of February 7, 2002.” What is your understanding of the leeway given military interrogators to deviate from the standards of the Geneva Conventions by the phrase “to the extent appropriate and consistent with military necessity?”

General FAY. I did not interview Lieutenant General Sanchez. We do not believe that Lieutenant General Sanchez and his staff relied directly on the 7 February 2002 document. The 7 February 2002 document led to the adoption of the 16 April 2003 policy that Secretary Rumsfeld approved for detainees at Guantanamo. The Guantanamo policy became a principal source for the CJTF–7 policies of September and October 2003. Our understanding is that the interrogators at Abu Ghraib did not have any leeway to deviate from the standards of the Geneva Conventions. (See also answer to question #9.)

8. Senator LEVIN. General Fay, do you believe that military interrogators understood that guidance?

General FAY. I do not think that the military interrogators at Abu Ghraib understood the guidance issued by CJTF–7 as it was issued in September and October 2003.

9. Senator LEVIN. General Fay, how did the President’s February 7, 2002 decision end up influencing interrogation guidelines in Afghanistan and Iraq?

General FAY. I did not investigate interrogation operations in Afghanistan. The President’s decision dated February 7, 2002 influenced policy in Iraq indirectly in that it was used to justify methods approved and used in Afghanistan and Guantanamo. Written documents from both places were then used as references for drafting the Iraq policy/guidance documents. Additionally, military interrogators had worked in both Afghanistan and Guantanamo before being sent to Iraq and brought the techniques used in those other places with them.

10. Senator LEVIN. General Jones, do you agree with the Schlesinger Panel’s statement that General Sanchez used the reasoning in the President’s determination when formulating the aggressive interrogation techniques for Iraq and, if so, what arguments from that decision did General Sanchez rely on when he approved those interrogation methods?

General JONES. Lieutenant General Sanchez repeatedly stated that the Geneva Conventions applied to detainees in Iraq. He also reiterated this guidance in his policy memos. CJTF–7 Interrogation and Counter-Resistance Policy memos were modeled after the 16 April 2003, Secretary of Defense (Secretary of Defense) memo directed to Guantanamo Bay, but modified for applicability to a theater of war in which Geneva Conventions apply. I have no evidence that Lieutenant General Sanchez or anyone on his staff had knowledge of the President’s Memorandum dated February 7, 2002, subject: Humane Treatment of al Qaeda and Taliban Detainees. To the extent that Lieutenant General Sanchez and his staff relied on the Guantanamo policy and to the extent that policy was based on the President’s 7 February 2002 document, Lieutenant General Sanchez relied indirectly (but unknowingly) on the President’s determination.

CONFUSION

11. Senator LEVIN. General Jones and General Fay, your reports contain numerous findings concerning confusion or lack of clarity:

- There was a lack of clear command and control of detainee operations at the CJTF–7 level;
- The fragmentary order appointing Colonel Pappas as the commander at Abu Ghraib was unclear;
- The lines of authority and accountability between Military Intelligence (MI) and Military Police (MP) were unclear and undefined;
- Responsibilities for managing operations and establishing good order and discipline in the Joint Interrogation and Debriefing Center were unclear and led to lapses in accountability; and most importantly,
- DOD’s development of multiple policies on interrogation operations for use in different theaters or operations confused Army and civilian interrogators at Abu Ghraib.

General Fay, as you succinctly put it in your report: “Concepts for the non-doctrinal, non field-manual approaches and practices came from documents and personnel in GTMO and Afghanistan. By October 2003, interrogation policy in Iraq had

changed three times in less than 30 days and it became very confusing as to what techniques could be employed and at what level non-doctrinal approaches had to be approved.”

Who was responsible for the confusion that General Fay reports?

General JONES and General FAY. The confusion referred to was the result of the lack of a clear Military Intelligence Chain of Command for Interrogation Operations. The Joint Interrogation and Debriefing Center (JIDC) was an organization quickly patched together by bringing together individuals from all over the Army. Additionally, civilian contractors were used and that further complicated the situation and contributed to the confusion due to their inadequate training and organization. There was only one officer, a captain, assigned to the JIDC that had any interrogation experience. At the CJTF-7 level there was also an almost total lack of experience on the C2 staff on interrogation operations and the C2 staff was never adequately staffed during this critical time period. The Staff Judge Advocate office was also short on experience in the area of interrogation operations and it too was understaffed for all the demands being placed on it during the period being investigated. Lines of authority and accountability for executing the interrogation mission were not established below the brigade level in the 205th MI Bde. The establishment of the JIDC and appointment of LTC Jordan was a measure intended to provide leadership within the interrogation soldiers working at Abu Ghraib. LTC Jordan did not execute his leadership role or take ownership of the mission given. There was a clear failure to establish leadership at the lower levels of responsibility and to provide appropriate guidance to soldiers executing the mission.

COERCIVE INTERROGATION TECHNIQUES

12. Senator LEVIN. General Fay, one of the findings of your report is that as a result of national policies and DOD directives that were inconsistent with Army doctrine on detainee treatment or interrogation tactics, leaders at CJTF-7 developed interrogation policies and practices that lacked a basis in Army interrogation doctrine. Which “national policies and DOD directives” are you referring to? Would these include:

- The December 2002 Secretary of Defense memo—later rescinded—approving for use at Guantanamo interrogation techniques including nudity, exploiting detainees’ fears, including through use of dogs, and stress positions.
- The April 16, 2003, memorandum signed by Secretary of Defense Rumsfeld approving approaches for use on Guantanamo “unlawful” combatants, including six techniques not included in the Army FM 34-52.
- A Special Operation Forces (SOF) Standard Operating Procedures (SOPs) which, according to the Schlesinger Report, referred to non-doctrinal techniques in use in Afghanistan starting in late 2002.
- The Guantanamo SOPs provided by General Miller to CJTF-7 during his assessment visit in early September 2003.

General FAY and General JONES. The national policies and DOD directives referred to did include the December 2002 Secretary of Defense memo, the April 16, 2003 Secretary of Defense memo, and the Guantanamo SOPs. We did not refer to a SOF/SOP from Afghanistan. The SOF/SOP we referred to was from Joint Task Force (JTF)-121 that was operating in Iraq and the document was titled “Policy No. 1—Battlefield Interrogation Team and Facility (BIT/F) Policy” dated 15 July 2003. However, based on my investigation, I believe the contents of that policy were derived from SOF operations in Afghanistan.

13. Senator LEVIN. General Fay, did these high-level policy memoranda contribute to the use at Abu Ghraib of aggressive interrogation techniques not provided for in the Army FM 34-52?

General FAY. Yes. As noted in my report the confusion created by the lack of clear guidance to the interrogators at Abu Ghraib led to the use of dogs during interrogations, improper use of isolation that amounted to abuse, and forced nudity that was intended to be humiliating to the detainees.

14. Senator LEVIN. General Fay, in your personal opinion, why did soldiers get the impression that techniques approved by the Secretary of Defense or incorporated into the SOPs of U.S. forces in Afghanistan were condoned for use in Iraq?

General FAY. My opinion as investigating officer is that when the conflict in Iraq first began there was no written guidance on interrogation operations except for the Army FM. When the conflict shifted from combat operations to a counterinsurgency

the soldiers involved in interrogations determined that they needed more than what the FM provided as regards to techniques. Some of them had served in Afghanistan and saw the developing situation in Iraq as being similar to that situation and thought that they should have the same authorities in Iraq that they had in Afghanistan.

“GLOVES COMING OFF”

15. Senator LEVIN. General Fay, according to press reports, an Army intelligence officer at CJTF-7 in Baghdad issued a memo to subordinates in July 2003 stating that “the gloves are coming off, gentlemen” regarding the treatment of insurgents detained in Iraq. The memo solicited a “wish list” of interrogation techniques felt to be effective. The memo reportedly also cited the senior intelligence officer at CJTF-7 as stating that “we want these individuals broken.” (Washington Post, 8/23/04; Baltimore Sun, 8/24/04; New York Times, 8/24/04.) In the course of your investigation, did your team see this memorandum or question senior officers regarding its contents?

General FAY. During our investigation we did not see that specific memo. However, we now have a copy of it. It was actually an e-mail message. Although we did not see that specific e-mail in initial investigation, we did speak with many witnesses that substantiated what that message and other such communications were saying. Those communications were both verbal and written and their intent was to heighten the awareness of the interrogators regarding the urgency of their mission and to ensure they were taking all possible steps within the law and regulations to elicit information. We found no documentation that directed that law or regulation be violated in order to obtain that information. No one told us of any verbal direction they received to suggest they violate law or regulation.

16. Senator LEVIN. General Fay, did you find evidence that senior officers at CJTF-7 encouraged the use of harsher interrogation techniques on insurgents detained during the period in question?

General FAY. By senior officers I understand you to mean general officers. I did not find any evidence that suggests that senior officers encouraged the use of harsher techniques. I did find that Lieutenant General Sanchez wanted to make sure that interrogators were using all the techniques available to them that were in accordance with laws and regulations. I am assuming that by “insurgents” you are referring to all detainees at Abu Ghraib (many of whom were not insurgents).

17. Senator LEVIN. General Fay, the memo also reportedly solicits a list of individuals in detention who would come under the category of “unlawful combatants,” stating that such individuals “may be treated as criminals under the domestic law of the captor.” Is it your understanding that security internees at Abu Ghraib constituted “unlawful combatants” for purposes of the Geneva Conventions?

General FAY. As stated above, I did not review the specific memo in question. All detainees were to be treated in accordance with the applicable Geneva Conventions.

18. Senator LEVIN. General Fay, did your investigation uncover any evidence of confusion regarding the proper categorization of individuals captured in Iraq?

General FAY. I did not find confusion as regards how detainees were to be categorized. There was a huge challenge connected to finding out enough information on detainees in order to categorize them properly.

MAJOR GENERAL MILLER/GTMO ROLE

19. Senator LEVIN. General Fay, didn’t the decision to send Major General Geoffrey Miller to Abu Ghraib, and the subsequent deployment of teams from Guantanamo Bay and Fort Huachuca to train military intelligence personnel at Abu Ghraib in Guantanamo operations, lead to the perception that techniques employed at Guantanamo Bay—which you find include stress positions, isolation for up to 30 days, removal of clothing, and the use of dogs to exploit detainees’ phobias—were being encouraged or condoned for use at Abu Ghraib?

General FAY. Major General Miller’s visit to Iraq and Abu Ghraib did not result in the abuses detailed in my report. The use of dogs during interrogations did result from a miscommunication between Major General Miller and Colonel Pappas as noted in Question #6. However, the terrible, purposeful, abuses regarding dogs that occurred cannot in any way be considered a result of that miscommunication.

20. Senator LEVIN. General Fay, who directed that Major General Miller go to Abu Ghraib in August 2003?

General FAY. Major General Miller was sent to Iraq as a result of a request from Major General Ronald Burgess, Director of Intelligence (J2), Joint Chiefs of Staff.

CONDUCT OF THE INVESTIGATIONS

21. Senator LEVIN. General Fay, the Schlesinger Report (p. 74) refers to written objections filed by the 72nd MP Company out of Nevada, calling into question interrogation practices of the MI brigade at the Abu Ghraib facility regarding nakedness of detainees. Did you investigate these objections by the 72nd MP Company?

General FAY and General JONES. We interviewed seven soldiers from the 72nd MP Company, whom we believed to be the most knowledgeable regarding the events that took place at the "hard site," in Nevada during one of their drill weekends. The results of those interviews were considered during the conduct of the investigation.

22. Senator LEVIN. General Fay, in one MI soldier's statement he mentions a journal kept by a member of the 72nd MP Company detailing incidents of ill-treatment. Did you follow up on this reference to a journal?

General FAY. We identified the individual as being SPC Donna Menesini, 72nd MP Company. She was interviewed by the media and stated that contrary to reports they had received she kept a diary of her experiences in Iraq but none of those involved detainee abuse. See Associated Press Report dated May 14, 2004. SPC Menesini was also interviewed by a team from the Nevada National Guard and told them the same thing.

23. Senator LEVIN. General Fay, a September 6, 2004, report in Newsweek criticizes your investigation for leaving out an "especially damaging allegation" of abuse from the final report. The incident reportedly involved interrogators physically abusing the teenage son of an Iraqi general in order to "break" the general. The article cites a sworn statement by a military intelligence officer saying that "interrogators took his son and got him wet," "put mud on face," and "placed the son in an area where the father could observe him." According to the report, "this broke the general." Did you receive any statements relating to this incident?

General FAY. We did take two statements that related to the incident described in question 23. Those statements are attachments to our report. The statements are from Sergeant Samuel J. Provance and SPC James C. Gehman. The two witnesses did not know the identity of the interrogators and we could find no record of this interrogation. It was therefore impossible to verify if abuse occurred during this event.

24. Senator LEVIN. General Fay, are there any allegations of incidents of abuse that were not included in your report? If so, why?

General FAY. All allegations of abuse at Abu Ghraib prison from July 2003 through January 2004 were included to the best of my knowledge. We also had all statements reviewed by an experienced investigator who was not otherwise a part of the investigative team and he found no other allegations that were not addressed.

25. Senator LEVIN. General Jones, your tasking was to examine whether organizations or personnel above the 205th MI Brigade chain of command, or events and circumstances outside the 205th MI Brigade, were involved, directly or indirectly, in the activities regarding alleged detainee abuse at Abu Ghraib. Did you interview any officers besides General Sanchez and General Fast?

General JONES. The scope of my investigation was the chain of command above the 205th MI Brigade, with a specific task to interview Lieutenant General Sanchez. I relied on the very thorough interviews and sworn statements that had been collected by Major General Fay and other investigations to respond to the Appointing Authority directive. In addition to Lieutenant General Sanchez and Major General Fast, I interviewed LTC William H. Brady, LTC Melissa A. Sturgeon, and Major William (nmn) Ponce who were assigned to the C2, CJTF-7.

26. Senator LEVIN. General Jones, did General Sanchez and General Fast's statements ever conflict with statements by others interviewed by General Fay, such as General Karpinski or subordinate officers?

General JONES. Certain statements made by BG Karpinski were not in agreement with statements provided by Lieutenant General Sanchez or Major General Fast.

27. Senator LEVIN. General Jones, did you or General Fay go back and re-interview anyone as a result of conflicting statements provided by either General Sanchez or General Fast?

General JONES. I went back and questioned Lieutenant General Sanchez and Major General Fast as a result of subsequent statements made by BG Karpinski (who was interviewed by Major General Fay).

28. Senator LEVIN. General Jones, did you interview either the Deputy Commanding General or the Deputy J2 at CJTF-7?

General JONES. No. I relied on the interviews and sworn statements from Major General Fay's interviews.

29. Senator LEVIN. General Jones, did you interview anyone at CENTCOM? If so, whom did you interview? If not, why not?

General JONES. This was outside of the scope of my investigation. I did review CENTCOM orders and FRAGOs which were published and directed actions by the CJTF-7 during phase IV operations.

30. Senator LEVIN. General Jones, did you interview anyone on the Joint Staff? If so, whom did you interview? If not, why not?

General JONES. I did not interview anyone on the Joint Staff. This was out of the scope of my investigation. I did obtain documents from the Joint Staff which were needed to clarify orders and directives given to CENTCOM and had applicability to the Iraqi theater.

31. Senator LEVIN. General Jones, did you interview anyone other than military officers within the DOD? If so, whom did you interview? If not, why not?

General JONES. I did not. This was outside the scope of my investigation.

SCOPE OF THE INVESTIGATION

32. Senator LEVIN. General Jones and General Fay, did you investigate whether actions by the White House contributed to a perception among the military Intelligence Community of high-level pressure to produce intelligence?

General JONES and General FAY. Neither officer investigated this. Major General Fay asked all witnesses about "pressure." Those that answered that they felt significant pressure were asked where that pressure came from. No one mentioned pressure as coming from the White House.

33. Senator LEVIN. General Jones and General Fay, did any senior National Security Council (NSC) staff visit Abu Ghraib during the period in which abuses are alleged to have occurred? If so, who?

General JONES and General FAY. LTC Jordan did provide information to the media about pressure he felt as a result of a visit to Abu Ghraib by Ms. Townsend of the NSC staff. He did not mention that visit to me on the two interviews I had with him. When I asked for a third interview to cover this and other points I discovered during my investigation he declined to make any further statements on advice of his attorney. I do not know when Ms. Townsend visited Abu Ghraib.

I do not have any further information to answer Question #33.

34. Senator LEVIN. General Fay, did you investigate any abuses alleged to have occurred either at the point of capture or at division-level detention facilities prior to detainees arriving at Abu Ghraib?

General FAY. I did not investigate any abuses at point of capture or division level detention facilities. Those instances were not within the scope of my assignment. However, during my investigation of abuses at Abu Ghraib, alleged abuses were reported to me by Special Operations units. I reported those allegations to Lieutenant General Sanchez and he immediately ordered another separate investigation, now known as the Formica investigation, into those instances.

35. Senator LEVIN. General Fay, did you investigate the failure of medical personnel at Abu Ghraib to report indications of abuse of detainees that they may have seen or treated?

General FAY. I did investigate instances of medical personnel failing to report abuses they either saw directly or saw the results of during treatment. Those involved were medics, not medical doctors. There were two medics cited. We also in-

investigated an instance where a medical doctor failed to respond to a medical situation that required medical attention. See Incident #19 in the report of investigation.

36. Senator LEVIN. General Fay, in one of your findings, you state that medical records were requested but not obtained. Why were you unable to get these medical records?

General FAY. Although the medical personnel we interviewed told us that medical records were kept on the detainees, those records apparently were not maintained as detainees were released or transferred to Iraqi control. Even the records on some of the detainees that were still in our custody could not be located by the medical personnel. This is a significant shortcoming that was addressed in our recommendations.

37. Senator LEVIN. General Fay, what steps have been taken on the recommendation in your report that an inquiry be conducted into whether medical personnel were aware of or failed to document and report prisoner abuse?

General FAY. I do not know what specific steps have been taken.

QUESTIONS SUBMITTED BY SENATOR EDWARD M. KENNEDY

JAG INVOLVEMENT

38. Senator KENNEDY. General Jones and General Fay, to what extent did your investigation find that COL Marc Warren, his staff, and other JAG officers in Iraq (including CPT Fitch, MAJ Krazmier, and MAJ Franklin Raab named at page 25) gave incorrect legal advice on the application of the Geneva Conventions to interrogation of civilian detainees in occupation, or drafted interrogation standards not in compliance with the Geneva Conventions?

General FAY and General JONES. The Judge Advocate General (JAG) of the Army has initiated an inquiry into matters regarding the activities of Army lawyers in this situation and the sufficiency of legal advice given to commanders. It would be inappropriate for General Kern, Lieutenant General Jones, or Major General Fay to comment at this time.

39. Senator KENNEDY. General Jones and General Fay, if they gave correct advice, was it followed?

General JONES and General FAY. The JAG of the Army has initiated an inquiry into matters regarding the activities of Army lawyers in this situation and the sufficiency of legal advice given to commanders. It would be inappropriate for General Kern, Lieutenant General Jones, or Major General Fay to comment at this time.

40. Senator KENNEDY. General Jones and General Fay, during the period of September and October 2003, to what extent did consultation occur with legal officers outside of this command?

General JONES and General FAY. The JAG of the Army has initiated an inquiry into matters regarding the activities of Army lawyers in this situation and the sufficiency of legal advice given to commanders. It would be inappropriate for General Kern, Lieutenant General Jones, or Major General Fay to comment at this time.

41. Senator KENNEDY. General Jones and General Fay, to what extent did the legal staff have access to the "Working Group Report" headed by the General Counsel of the Department of the Air Force or drafts or extracts from this document?

General JONES and General FAY. The JAG of the Army has initiated an inquiry into matters regarding the activities of Army lawyers in this situation and the sufficiency of legal advice given to commanders. It would be inappropriate for General Kern, Lieutenant General Jones, or Major General Fay to comment at this time.

42. Senator KENNEDY. General Jones and General Fay, did the level of performance of such JAG officers meet appropriate professional standards of competence, and if not, did inadequate performance constitute dereliction of duty or otherwise merit consideration of Uniformed Code of Military Justice (UCMJ) or disciplinary action?

General JONES and General FAY. The JAG of the Army has initiated an inquiry into matters regarding the activities of Army lawyers in this situation and the sufficiency of legal advice given to commanders. It would be inappropriate for General Kern, Lieutenant General Jones, or Major General Fay to comment at this time.

43. Senator KENNEDY. General Jones and General Fay, did the understanding of the Geneva Conventions and other aspects of the law of occupation by COL Warren, his staff, and other JAGs in the command reflect adequate preparation by them and sufficient support by JAG resources at CENTCOM and DOD?

General JONES and General FAY. The JAG of the Army has initiated an inquiry into matters regarding the activities of Army lawyers in this situation and the sufficiency of legal advice given to commanders. It would be inappropriate for General Kern, Lieutenant General Jones, or Major General Fay to comment at this time.

44. Senator KENNEDY. General Jones and General Fay, were Major General Miller and his staff, notably his JAG adviser, aware of the legal standards applicable in occupation, as distinguished from those applicable in Afghanistan and Guantanamo, and if so, did they take these distinctions into account in their advice on interrogation in Iraq?

General JONES and General FAY. The JAG of the Army has initiated an inquiry into matters regarding the activities of Army lawyers in this situation and the sufficiency of legal advice given to commanders. It would be inappropriate for General Kern, Lieutenant General Jones, or Major General Fay to comment at this time.

CACI CONTRACT

45. Senator KENNEDY. General Fay, your report notes that there were significant problems with the CACI contract:

- CACI employees sat down with the contracting officer to write the contract requirements—a violation of Federal contracting rules. [Fay p. 49]
- The contract did not go through the normal contracting process, but through a loophole in the GSA Schedule. [Fay p. 49]
- Captain Wood at Abu Ghraib never received any guidance on how the CACI personnel were to be used, and the contracting manager was nowhere to be found. [Fay p. 50]
- Even contractors who had previous military intelligence backgrounds had little or no experience as interrogators. [Fay p. 51]
- Despite these deficiencies, some of the contract personnel were supervising military personnel, and vice versa. [Fay p. 51]

The problems with contractors are no small matter. Other contractor services at Abu Ghraib cost up to \$650 million. These are serious and possibly criminal problems, and we need to understand how they could have occurred. What organization within DOD requested the CACI contracts?

General FAY. The delivery order under the CACI contract was requested by CJTF-7 personnel. The chief proponent of the action was Colonel Boltz. He was initially the CJTF-7 Deputy Chief of Staff for Intelligence (C2) until the arrival of Major General Fast and then Colonel Boltz became the Deputy C2.

46. Senator KENNEDY. General Fay, who authorized the CACI contracts?

General FAY. The specific delivery order in question to CACI for interrogators was authorized by MG Walter Wojdakowski, Deputy Commanding General, CJTF-7.

47. Senator KENNEDY. General Fay, who decided that the CACI contract would go through the GSA schedule instead of through a separate RFP process?

General FAY. The interrogators and screeners at Abu Ghraib were actually provided under Delivery Orders awarded under a Blanket Purchase Agreement (BPA) with the National Business Center (NBC), an activity of the Interior Department. The BPA between CACI and NBC set out the ground rules for ordering from the GSA Schedule Contract GS-35F-5872H. CJTF-7 was the requiring and funding authority. The approval of the contract came from the NBC contracting office at Fort Huachuca, AZ. CACI already had a contract for military intelligence personnel support with V Corps. Assistant Deputy Chief of Staff, Intelligence, G2, V Corps LTC Brady knew that contract existed and when requirements were identified in Iraq he thought about using the V Corps contract because CJTF-7 was made up mostly of V Corps assets. Brady decided not to use the V Corps contract because the requirement would continue after V Corps returned to Germany and was replaced by another unit. One of the CACI Vice Presidents, Charles Mudd, was in Iraq at the time and suggested that CJTF-7 use the Fort Huachuca contract instead.

48. Senator KENNEDY. General Fay, what was the total value of the CACI contract?

General FAY. The value of the CACI interrogator Delivery Order NBCHA010005, which includes interrogators, is \$19,915,407. The value of the CACI screener Delivery Order NBCHA010005, which includes screener support, is \$3,222,502.80. There is another delivery order for screener support totaling \$21,799,921.00.

49. Senator KENNEDY. General Fay, what organization paid for the CACI contract?

General FAY. CJTF-7 was the funding authority.

50. Senator KENNEDY. General Fay, did you interview LTC Brady, the contracting officer?

General FAY. I did interview LTC Brady. However, he was never formally appointed as the contracting officer. In his words he was the closest thing they had in Iraq to a contracting officer for the CACI delivery order. His statements to me and to the V Corps Judge Advocate General are attachments to my report.

51. Senator KENNEDY. General Fay, what organization does LTC Brady work for?

General FAY. LTC Brady was on the CJTF-7 staff.

52. Senator KENNEDY. General Fay, did you investigate the circumstances of LTC Brady's contacts with CACI?

General FAY. I interviewed LTC Brady as part of my investigation.

53. Senator KENNEDY. General Fay, where does LTC Brady currently work?

General FAY. LTC Brady is currently assigned to Office of the G-2, HQ U.S. Army Europe, Heidelberg, Germany, APO AE 09102.

54. Senator KENNEDY. General Fay, were there any violations of Federal contracting rules in the award of the CACI contract?

General FAY. The use of the BPA noted above may have been a violation. Additionally, as noted in my report a CACI employee, Thomas Howard, participated with LTC Brady in writing the statement of work prior to issuance of the delivery order. This situation may have violated the provisions of a Federal Acquisition Regulation (FAR) 9.505-2(b)(1). Consulting with the CACI Vice President about the appropriate contract vehicle may have also been a violation.

55. Senator KENNEDY. General Fay, did Under Secretary Cambone, Major General Miller, Major General Fast, General Sanchez, Lieutenant General Boykin, or Colonel Warren have any knowledge of the CACI contract prior to knowing of the abuses at Abu Ghraib?

General FAY. Nothing in my investigation would indicate that Under Secretary Cambone, Major General Miller, Lieutenant General Boykin, or Colonel Warren had any knowledge of the CACI delivery order prior to knowing of the abuses at Abu Ghraib. Major General Fast did know that CACI was providing personnel support, but was not party to the contract discussions.

56. Senator KENNEDY. General Fay, did any of these individuals propose, request, authorize, approve, or fund the CACI contract?

General FAY. None of the above named individuals requested, proposed, authorized, approved, or funded the CACI delivery order in question.

INTERROGATION TECHNIQUES

57. Senator KENNEDY. General Jones and General Fay, how and under what authority did techniques like stripping detainees, using dogs to induce fear, and placing detainees in painful stress positions come into use in Afghanistan?

General JONES and General FAY. Issues pertaining to Afghanistan (CJTF-180) and Guantanamo were not within the scope of our investigation.

58. Senator KENNEDY. General Jones and General Fay, did CJTF-180 issue any formal orders or policies authorizing such methods prior to the March 2003 Special Forces SOPs?

General JONES and General FAY. Issues pertaining to Afghanistan (CJTF-180) and Guantanamo were not within the scope of our investigation.

59. Senator KENNEDY. General Jones and General Fay, were these procedures revised after April 2003 when Secretary Rumsfeld rescinded his approval of harsh interrogation techniques for Guantanamo? If not, why not?

General JONES and General FAY. Issues pertaining to Afghanistan (CJTF-180) and Guantanamo were not within the scope of our investigation.

60. Senator KENNEDY. General Jones and General Fay, did the Pentagon know the military was still using those methods?

General JONES and General FAY. Issues pertaining to Afghanistan (CJTF-180) and Guantanamo were not within the scope of our investigation.

61. Senator KENNEDY. General Jones and General Fay, when the Commander of CJTF-180 forwarded a list of techniques being used in Afghanistan to the Joint Chiefs in January 2003, why didn't the Pentagon use that opportunity to object to methods that clearly violated Army doctrine?

General JONES and General FAY. Issues pertaining to Afghanistan (CJTF-180) and Guantanamo were not within the scope of our investigation.

62. Senator KENNEDY. General Jones and General Fay, the Fay Report tells us that techniques such as forced nudity, sleep deprivation, and the use of dogs in interrogations violated international law and contributed to the abuses in Abu Ghraib. It also tells us that in December 2002, Secretary Rumsfeld authorized these techniques for Guantanamo and that in September 2003, General Sanchez authorized their use in Iraq. If so, don't these leaders bear a large share of responsibility for legitimizing methods designed to terrify and humiliate prisoners?

General JONES and General FAY. Lieutenant General Sanchez did not ever authorize forced nudity. His initial counterresistance policy authorized the use of dogs during interrogation if they were muzzled and under the control of a dog handler. If dogs were used in that way it would not have been a violation of any law or regulation. The subsequent policy issued in October removed the authority to use dogs. Sleep deprivation within reasonable bounds may not be a violation of law depending on the specifics of how it is administered and length of time. The brutal acts to terrify and humiliate detainees were not legitimized by Lieutenant General Sanchez.

Secretary Rumsfeld did authorize the removal of clothing in his December 2002 memo. His memo was for Guantanamo and never intended to be used in Iraq. After further legal review, that authority was rescinded 6 weeks later. Dogs were not used at Guantanamo in interrogations but only for detainee control and security. Such use does not violate law. The sleep deprivation issue is as stated above. The policies of the Secretary of Defense did not authorize or "legitimize" the detainee abuse that occurred at Abu Ghraib.

63. Senator KENNEDY. General Jones and General Fay, didn't these leaders authorize the commission of unlawful acts?

General JONES and General FAY. No.

64. Senator KENNEDY. General Jones and General Fay, referring to techniques such as the use of dogs, the Fay Report states that "at the time the soldiers or contractors committed the acts . . . some of them may have honestly believed the techniques were condoned." Since General Sanchez at one point specifically authorized the use of dogs in interrogation, and this and other coercive techniques appeared in lists of approved interrogation methods circulating in Abu Ghraib, didn't soldiers have reason to believe they were not only condoned, but encouraged?

General JONES and General FAY. As stated above, Lieutenant General Sanchez only authorized dogs in his first policy memo and only if they were muzzled and under the control of a dog handler. I believe your question refers to the IROE chart authored by Captain Wood. That chart specifically stated that the Geneva Conventions applied. It also listed techniques that did not need approval, none of which were abusive. It further listed techniques requiring CG (Lieutenant General Sanchez) approval. Of the more severe techniques on that list however, the only techniques Lieutenant General Sanchez actually approved were segregation for more than 30 days. Requiring the approval of a three star general does not indicate encouragement to use those techniques.

65. Senator KENNEDY. General Jones and General Fay, the Fay Report states: "Interrogations at Abu Ghraib . . . were influenced by several documents that spoke of exploiting the Arab fear of dogs." What were these documents and who drafted them?

General JONES and General FAY. These documents were: JTF-121 Policy No. 1-Battlefield Interrogation Team and Facility (BIT/F) Policy dated 15 July 2003. 519th MI Bn draft IROE titled Sadaam Fedeyeen Interrogation Facility approved by LTC Whalen on 7 August 2003 and sent to the 205th MI Brigade.

66. Senator KENNEDY. General Jones and General Fay, did they reflect widespread thinking in the Pentagon or Intelligence Community?

General JONES. Concur.

General FAY. This question goes beyond the scope of my investigation. I did not question anyone at the Pentagon as part of my investigation.

67. Senator KENNEDY. General Jones and General Fay, earlier this year, the Senate passed an amendment to the DOD authorization bill, sponsored by Senators Durbin and McCain, requiring the Pentagon to implement clear guidelines for the lawful and humane treatment of detainees. On June 15, DOD wrote Senator Warner that it opposed this provision on the grounds that such regulations are already in force. Do you believe that current interrogation guidelines are sufficiently clear and well-understood?

General JONES and General FAY. FM-34-52 is being rewritten, as is the Policy Guidance for Interrogation Operations, in order to ensure that they are clear. After publication it will be necessary to follow up to ensure that the new guidance is understood and is being taught properly to soldiers.

FIELD MANUAL 34-52

68. Senator KENNEDY. General Jones and General Fay, Field Manual 34-52 states U.S. interrogators should not engage in actions that would be considered unlawful if perpetrated by the enemy on American personnel. Did the interrogation methods approved by U.S. commanders for Afghanistan and Iraq meet that test?

General JONES and General FAY. Issues pertaining to Afghanistan were not within the scope of our investigation. Regardless of whether certain methods were approved, some of the activities perpetrated by U.S. personnel in Iraq were unlawful.

69. Senator KENNEDY. General Jones and General Fay, in your report, you concluded that had Army doctrine, expressed in FM 34-52, been followed faithfully, the abuses in Abu Ghraib would not have happened. Shouldn't the Pentagon affirm that this Field Manual will once again guide all interrogation policy?

General JONES and General FAY. FM-34-52 is being rewritten as is the Policy Guidance for Interrogation Operations in order to ensure that they are clear. After publication it will be necessary to follow up to ensure that the new guidance is understood and is being taught properly to soldiers. The field manual applies only to military servicemen and women, so steps must be taken to ensure that all U.S. personnel operate properly.

DECISION ON THE GENEVA CONVENTIONS

70. Senator KENNEDY. General Jones and General Fay, how did the President's February 7, 2002 decision on the Geneva Conventions influence interrogation guidelines in Afghanistan and Iraq?

General JONES and General FAY. See answers to questions #7 and #9.

71. Senator KENNEDY. General Jones and General Fay, what arguments from that decision did General Sanchez rely on when he approved the use of dogs and other coercive techniques as interrogation methods?

General JONES and General FAY. Lieutenant General Sanchez repeatedly stated that the Geneva Conventions applied to detainees in Iraq. He also reiterated this guidance in his policy memos. CJTF-7 Interrogation and Counter-Resistance Policy memos were modeled after the 16 April 2003, Secretary of Defense memo directed to GTMO, but modified for applicability to a theater of war in which Geneva Conventions apply. We have no evidence that Lieutenant General Sanchez had knowledge of the President's Memorandum dated February 7, 2003, subject: Humane Treatment of al Qaeda and Taliban Detainees at the time the CJTF-7 Interrogation Policy was formulated.

72. Senator KENNEDY. General Jones and General Fay, when he advised the President on his February 7 decision, White House legal counsel Alberto Gonzales passed on warnings from Secretary Powell and the Joint Chiefs that a failure to

apply the Geneva Conventions to all detainees “could undermine U.S. military culture which emphasizes maintaining the highest standards of conduct in combat.” To what extent did this in fact happen?

General JONES and General FAY. This issue is outside of the scope of our investigation. Our investigation was limited to Abu Ghraib. We did not uncover any facts that would suggest that the President’s memo was in any way considered by those that committed the abuses. As stated above, all personnel interviewed knew that the Geneva Conventions applied to detainees in Iraq.

JUSTICE DEPARTMENT MEMO

73. Senator KENNEDY. General Jones and General Fay, the Schlesinger Report says that the Justice Department Office of Legal Counsel (OLC) memo on torture influenced the development of interrogation guidelines at the Pentagon. What impact did it have and was it seen as a definitive legal opinion by DOD?

General JONES and General FAY. There is no evidence to suggest the DOJ memo had any direct impact on operations at Abu Ghraib.

CIA INTERROGATION PRACTICES AND GUIDELINES

74. Senator KENNEDY. General Jones and General Fay, how do CIA interrogation practices and guidelines differ from the military’s and have they been revised since the Abu Ghraib scandal came to light?

General JONES and General FAY. This issue is outside of the scope of our investigation.

75. Senator KENNEDY. General Jones and General Fay, did CIA interrogators introduce and influence the military to adopt in Afghanistan and Iraq coercive interrogation techniques that it employed against senior Al Qaeda suspects in its custody?

General JONES and General FAY. We did not find any evidence to suggest that CIA interrogators introduced or influenced the military in adoption of coercive techniques. The CIA did not fully cooperate in our investigation.

76. Senator KENNEDY. General Jones and General Fay, your report concluded that every agency should follow the same interrogation policy when they work together in the same theater of action. How can we ensure this happens?

General JONES and General FAY. DOD, through the combatant commander, must document and enforce adherence by other government agencies while conducting detainee operations at DOD facilities with established DOD practices and procedures.

77. Senator KENNEDY. General Jones and General Fay, should the President direct the CIA to adopt and publish a policy that’s consistent with the Army’s FM 34–52?

General JONES and General FAY. This issue is outside of the scope of our investigation.

GHOST DETAINEES

78. Senator KENNEDY. General Jones and General Fay, who is responsible for hiding “ghost detainees” from the Red Cross?

General JONES and General FAY. Based on our investigation, the responsibility would be shared among the yet unknown CIA personnel, Colonel Boltz, Colonel Pappas, and LTC Jordan. The leader of the MP unit at Abu Ghraib, LTC Phillabaum, also bears responsibility since he allowed the ghost detainee situation occur in a confinement facility he was responsible for keeping to Army standards. In general, the military commander in charge of a DOD facility housing detainees is responsible for documentation, security, and safety of detainees.

79. Senator KENNEDY. General Jones and General Fay, if this practice of hiding ghost detainees from the Red Cross violates the Geneva Conventions, why did Secretary Rumsfeld OK it?

General JONES and General FAY. We found no evidence that Secretary Rumsfeld authorized it for any detainees at Abu Ghraib. Situations and approvals at other detainment facilities in Iraq were not within the scope of our investigation.

INTERROGATION TECHNIQUES VIOLATIONS

80. Senator KENNEDY. General Jones and General Fay, your report says that some of the interrogation techniques employed in Iraq violated the Geneva Conventions. Didn't they also violate the Convention Against Torture and Other Cruel, Inhuman, and Degrading Treatment, as well as U.S. military doctrine and regulations, and if so, shouldn't such techniques have been banned in Guantanamo and Afghanistan even if the President decided the Geneva Conventions didn't apply there?

General JONES and General FAY. This issue is outside of the scope of our investigation and should be answered by the DOD General Counsel.

U.S. POLICY REGARDING DETAINEES WORLDWIDE

81. Senator KENNEDY. General Jones and General Fay, on June 25, 2003, the DOD General Counsel wrote a letter to Senator Leahy stating that it was U.S. policy that no detainee anywhere in the world would be subjected to treatment that would be considered cruel and unusual in the U.S. under the 5th, 8th, and/or 14th Amendments to the Constitution. Was that standard followed in Guantanamo, Afghanistan, or Iraq?

General JONES and General FAY. The question is outside the scope of our investigation and should be answered by DOD General Counsel.

82. Senator KENNEDY. General Jones and General Fay, were commanders aware of this policy when they adopted interrogation rules?

General JONES and General FAY. We do not know the answer to this question. The Commander of CJTF-7 did make clear that detainees were to be treated in accordance with the Geneva Conventions.

83. Senator KENNEDY. General Jones and General Fay, did the Pentagon make any effort to enforce this policy?

General JONES and General FAY. This issue is outside of the scope of our investigation and should be directed to the DOD.

OVERSIGHT

84. Senator KENNEDY. General Jones and General Fay, did either of you personally question all of the military intelligence and military police personnel who had been assigned to the "guard force," security duty, or escort duty at Abu Ghraib or who in any other way were in close contact with the interrogators, the Military Police, the medics, or the CIA personnel or with anyone else who had observed or participated in the alleged abuses?

General JONES and General FAY. During the period investigated from June 2003 until January 2004 there were well over 2,000 U.S. military personnel at Abu Ghraib for at least some part of that time. I or a member of my investigation team interviewed all U.S. personnel whom we believed had information germane to the scope of this investigation unless those persons invoked their rights against self-incrimination. We also used and referred to the interviews conducted by Major General Taguba as well as the Army CID investigators. Additionally, we interviewed three detainees that were not interviewed by Major General Taguba. In all, over 170 interviews were conducted.

85. Senator KENNEDY. General Jones and General Fay, did either of you personally question the personnel who had not been questioned by CID because they had originally answered in the negative when informally surveyed by CID as to their knowledge of abuses?

General JONES and General FAY. I interviewed many of those personnel who completed the survey done by CID who had answered in the negative depending if I believed they might have information germane to the investigation.

I did not interview personnel surveyed by the CID.

86. Senator KENNEDY. General Jones and General Fay, did either of you personally question all members of General Pappas' staff, including Major Potter, the Deputy JIDC Commander?

General JONES and General FAY. Major Potter was the Deputy Commander of the 205th Military Intelligence Brigade, not of the JIDC. Major General Fay interviewed Major Potter and Major Williams. Both were staff members of the 205th MI Brigade

commanded by Colonel Pappas. Major General Fay's investigation team also interviewed Colonel Pappas' Judge Advocate, Captain Fitch.

87. Senator KENNEDY. General Jones and General Fay, did either of you personally question each of the persons listed on the JIDC organization chart dated January 23, 2004?

General JONES and General FAY. I and my team interviewed those that I felt might have information germane to the investigation who did not exercise their right against self-incrimination.

88. Senator KENNEDY. General Jones and General Fay, did either of you personally question any of the FBI or CIA personnel who were assigned at any time during 2003 or January 2004 to Abu Ghraib or other detention or interrogation functions or facilities?

General JONES and General FAY. I did not see a need to question any FBI personnel. I was denied access to CIA personnel.

89. Senator KENNEDY. General Jones and General Fay, did either of you personally question to the extent some such potential witnesses were not questioned by either of you, please list each such person and the reason he/she was not questioned by you, and if questioned by someone else, whether either of you personally reviewed the results and whether and why you determined that direct inquiry by one of you was not called for.

General JONES and General FAY. See answers above. The team attempted to question all relevant witnesses.

90. Senator KENNEDY. General Jones and General Fay, did either of you personally question all those who may have observed General Sanchez's visits to Abu Ghraib as to exactly where he went and what he saw, and particularly whether he saw the very large version of the IROE posted on the premises?

General JONES. Lieutenant General Sanchez asserts that he first saw the IROE poster during his testimony before the Senate Armed Services Committee in May 2004.

General FAY. I interviewed at least three people that were present during that visit, Colonel Pappas, LTC Jordan, and Captain Wood. Others were no doubt present but no one brought it up as an issue. Whether or not Lieutenant General Sanchez ever saw the chart in question was not asked.

91. Senator KENNEDY. General Jones and General Fay, is it true that there was no permanent or separate night shift at Abu Ghraib, but that various personnel were assigned to night duty as needed and as available?

General JONES and General FAY. As regards to the MPs, there was a specific night shift assigned to the hard site. As regards MI, there was no permanent or separate night shift and personnel were used on an as needed and as available basis. There had been an early attempt to split responsibilities day and night between the 519th MI Battalion interrogators and the 323rd MI Battalion interrogators when they were the only MI units there. But that split seems to have only lasted a short time before the JIDC was organized and divided into Tiger Teams.

[Whereupon, at 1:17 p.m., the committee adjourned.]

THE REPORT OF THE INDEPENDENT PANEL TO REVIEW DEPARTMENT OF DEFENSE DE- TENTION OPERATIONS

THURSDAY, SEPTEMBER 9, 2004

U.S. SENATE,
COMMITTEE ON ARMED SERVICES,
Washington, DC.

The committee met, pursuant to notice, at 2:41 p.m., in room SH-216, Hart Senate Office Building, Senator John Warner (chairman) presiding.

Committee members present: Senators Warner, McCain, Inhofe, Sessions, Collins, Talent, Graham, Cornyn, Levin, Kennedy, Lieberman, Reed, E. Benjamin Nelson, Dayton, and Pryor.

Committee staff members present: Judith A. Ansley, staff director; and Leah C. Brewer, nominations and hearings clerk.

Majority staff members present: Charles W. Alsup, professional staff member; Regina A. Dubey, research assistant; Paula J. Philbin, professional staff member; and Lynn F. Rusten, professional staff member.

Minority staff members present: Richard D. DeBobes, Democratic staff director; Daniel J. Cox, Jr., professional staff member; and William G.P. Monahan, minority counsel.

Staff assistants present: Alison E. Brill, Andrew W. Florell, Catherine E. Sendak, and Nicholas W. West.

Committee members' assistants present: Christopher J. Paul, assistant to Senator McCain; John A. Bonsell, assistant to Senator Inhofe; Clyde A. Taylor IV, assistant to Senator Chambliss; Meredith Moseley, assistant to Senator Graham; Russell J. Thomasson, assistant to Senator Cornyn; Mieke Y. Eoyang, assistant to Senator Kennedy; Frederick M. Downey, assistant to Senator Lieberman; Elizabeth King, assistant to Senator Reed; Davelyn Noelani Kalipi, assistant to Senator Akaka; William K. Sutey, assistant to Senator Bill Nelson; Andrew Shapiro, assistant to Senator Clinton; and Terri Glaze, assistant to Senator Pryor.

OPENING STATEMENT OF SENATOR JOHN WARNER, CHAIRMAN

Chairman WARNER. The committee will come to order. I apologize to our distinguished panel of witnesses. The Senate has had a series of votes. One is still underway, but I think we must get started here. I anticipate, here he comes right now, the distinguished ranking member any moment.

We meet today to receive the testimony on the final report of the Independent Panel to Review Department of Defense Detention Operations, commonly referred to as the Schlesinger-Brown report. We welcome our witnesses: Dr. Schlesinger, chairman of the panel; and Dr. Brown, a distinguished member of the panel. Two other members of the panel, former Congresswoman Tillie Fowler, and retired General Chuck Horner, were unable to be with us today.

We commend you all for a very splendid job. It was an important one at a critical time. I commend the Secretary of Defense for reposing in you the trust that he has and will always have in two former distinguished colleagues and close personal and professional friends.

On May 12, the Secretary of Defense chartered the Independent Panel to Review the Department of Defense Detention Operations, and I quote from his charter: "It would be helpful to me to have your independent professional advice of the issues that you consider most pertinent related to the various allegations. I am especially interested in your views on the cause of the problems and what should be done to fix them."

I say to you gentlemen and your panel in absentia, the other two members, you have done just that. You have stayed to the charter, and indeed I think you have showed a measure of independence which the Secretary and indeed Congress anticipated. You did it pragmatically and fairly.

At this point numerous investigations are being conducted under the Uniform Code of Military Justice (UCMJ). Trials are ongoing. Several have already been tried and sentenced or have received nonjudicial and administrative punishments. In addition, 7 of the 11 senior level reviews of detainee operations and allegations of detainee abuse throughout the Department of Defense (DOD) have been completed, and 3 more will be completed in the very near future.

Again, I commend the Secretary and the Department for the manner in which they have confronted these important issues. I find the Kern report, for example, I speak for myself, but other colleagues I think share these views, did an equally fine and commendable job.

It is noteworthy that the Secretary of Defense sought your independent professional advice on detainee abuses, what caused them, and what actions should be taken to prevent their repetition. We have shown the world that we are a Nation of laws. We will investigate wrongdoing and those found accountable and responsible will be dealt with accordingly.

The findings contained in this report before us today are indeed sobering. It is important to note your conclusion that the abuse the world saw in the infamous photographs from the Abu Ghraib prison "were not part of an authorized interrogation procedure nor were they directed at intelligence targets. They represent a deviant behavior and a failure of military leadership and discipline."

You do note, however, that other abuses occurred during interrogation activities that were not photographed both in Iraq and Afghanistan. You conclude that no approved procedures, policy, doctrine, or training called for, allowed, or encouraged the kind of abuses we have witnessed.

But you also advise the following: "The abuses were not just the failure of some individuals to follow known standards and they are more than the failure of a few leaders to enforce proper discipline. There is both institutional and personal responsibility at higher levels."

When Dr. Schlesinger and other members of the panel released the report on August 24, Dr. Schlesinger stated, "We believe there is institutional and personal responsibility right up the chain of command as far as Washington is concerned." I hope today that you will elaborate on that very important personal opinion and I presume that of the panel you represent, and what do you mean by responsibility and how high up the chain of command that responsibility goes.

Your report clearly establishes accountability up to the level of the Military Intelligence (MI) and Military Police (MP) Brigade commanders at Abu Ghraib, but the report is less clear on the accountability, to the degree it exists, of higher commanders and their staff, although significant failures and shortcomings were identified in your report. I ask that you clarify these conclusions about accountability. Such judgments are subjective but your collective professional judgment is of great value to the committee, to the DOD, and to the country as a whole.

During your press conference on this report, you specifically were asked about Secretary Rumsfeld, whether or not he should resign because of the problems identified. Dr. Brown stated, and I quote him, "If the head of a Department had to resign every time anyone down below did something wrong, it would be a very empty cabinet table." Your views on the accountability of the Secretary will be again reviewed with both of you today.

We seek your counsel on what must be done to preclude a repetition of such abuses, how justice is best served in restoring good order and discipline to our Armed Forces, and what constructive role this committee can continue to provide through its oversight responsibilities. As we continue to assemble the facts concerning allegations of detainee abuse at Abu Ghraib and elsewhere, it is important that we keep these incidents in context. You were clear on this point in your report. Over the past 3 years, the U.S. has apprehended over 50,000 personnel in Iraq and Afghanistan. As of mid-August 2004, only 66 out of the 50,000 gave rise to allegations of abuse that had been substantiated with one-third to one-half of those incidents occurring at the point of capture or during transit, periods which are often in the very heat of battle and extraordinary stress. Thousands of soldiers, sailors, and airmen have done their job humanely and honorably, 99.9 percent, throughout these two operations and elsewhere. They are as horrified or more horrified than anybody about the abuses of their fellow soldiers in uniform.

I want to commend the independent panel for also pointing out the need for urgency in providing well-documented policy, procedures, and training to our troops on approved interrogation techniques in order to counteract the current chilling effect the reaction to the abuses has had on the collection of valuable intelligence through interrogations. Intelligence, especially human intelligence, is critical to our success in the global war on terror. Our deployed forces throughout the world, wherever they are today, must have

the ability in obtaining such intelligence and have the confidence in the techniques, the training, and leadership in obtaining that intelligence. The pendulum could well have swung too far, and we must be certain to right that position.

As I said at our earlier hearing today, this report and others before us should dispel the notion that the Armed Forces cannot investigate itself. That is the DOD of the executive branch. All of the investigations, in the opinion of this Senator, have been thorough, professional, frank assessments that have contributed to an understanding of the complexities and the demands of detainee operations in a combat environment. All have provided important recommendations for how to correct the problems identified. We should all have confidence that the UCMJ and the values held dear by our Armed Forces will ensure that justice will be served. We have the assurance of senior leaders of the Armed Forces and the DOD that corrective measures have been and are being implemented to preclude the possibility of such a lapse of leadership and discipline in the future. We, in Congress, must work with the Department to ensure these corrective actions are effective and continue to take place.

We also have responsibility to remember the vast majority of our brave men and women in uniform were performing remarkable tasks at great risk around the world on a daily basis, in some cases making the ultimate sacrifice of loss of life and limb, to win the war on terror performing their duties in the finest traditions of our military. We honor their service and that of their families. Our efforts in gathering this information and openly discussing it with the American people and the world are intended to strengthen the Armed Forces.

I commend our witnesses again for their participation and their colleagues for this excellent report.

Senator Levin.

STATEMENT OF SENATOR CARL LEVIN

Senator LEVIN. Thank you, Mr. Chairman. Let me join you in welcoming our two very distinguished witnesses today and thanking them for, literally, a lifetime of service. We hope that service continues for a long time.

Their report builds upon the reports of previous investigations and assessments, including the investigation of intelligence activities at Abu Ghraib, which was the subject of the committee's hearing this morning.

This panel's report concluded, despite numerous previous assertions that the abuses at Abu Ghraib were the work of a small handful of rogue military police, that in the words of the panel before us, "there is both institutional and personal responsibility at higher levels." The report cites a number of developments that were contributing factors to the detainee abuse.

The first contributing factor was the issuance of a series of policy memoranda from the President and the Secretary of Defense on down that established a different process for the treatment of the Taliban and Al Qaeda detainees than that which had traditionally been applied in our Nation's wars. That treatment was based upon legal opinions from the Office of Legal Counsel (OLC) of the De-

partment of Justice (DOJ), including one dated August 1, 2002 that, according to this panel, “held that in order to constitute torture, an act must be specifically intended to inflict severe physical pain and suffering that is difficult to endure.”

Accordingly, Secretary Rumsfeld, responding to a request from the field, authorized some 16 additional interrogation techniques for use at Guantanamo beyond the 17 techniques that were authorized under the military’s longstanding doctrine. Although the Secretary soon thereafter rescinded most of the additional interrogation techniques and directed that the more aggressive techniques could be used only with his approval, the more aggressive original techniques were applied in Afghanistan and migrated to Iraq where they were used at Abu Ghraib.

Moreover, although it was decided that the Geneva Conventions would apply to the conflict in Iraq and would govern the treatment of all detainees there, Lieutenant General Sanchez, the commanding general of the Combined Joint Task Force-7 (CJTF-7), issued a memorandum on September 14, 2003, authorizing a dozen interrogation techniques beyond those authorized by standard DOD doctrine, including five which went beyond the techniques approved by Secretary Rumsfeld for Guantanamo. While General Sanchez’s memorandum was subsequently rescinded and the new guidance that he issued was closer to that which was authorized by DOD doctrine, the result was severe confusion in the field, and in the words of the panel before us, “the belief that additional interrogation techniques were condoned.”

We heard this morning from General Fay whose report states, “By October 2003, interrogation policy in Iraq had changed three times in less than 30 days and it became very confusing as to what techniques could be employed and at what level non-doctrinal approaches had to be approved.”

Compounding the problem of confusing and inconsistent guidance was the lack of leadership and oversight by those in command and senior staff positions. Those failures took place despite the fact that there was evidence of abuse that surfaced, including a report in November 2003 from the International Committee of the Red Cross (ICRC) detailing abuses that were actually seen by ICRC personnel at Abu Ghraib.

Another contributing factor was the failure of higher authority both to properly plan for the insurgency that took place after major combat operations, and that continues to this day, as well as the failure to promptly adjust to the insurgency after it became a clear reality.

According to our panel’s report today, the October 2002 Central Command war plan “presupposed that relatively benign stability and security operations would precede a hand-over to Iraq’s authorities.” In that regard, I am reminded that General Franks told Senator Warner and me that he was told by the civilian leadership of the DOD to leave the planning for the stability and security phase of Operation Iraqi Freedom to the Pentagon’s civilian leadership. In any event, once it became clear in July 2003 that there was a major insurgency growing in Iraq, senior leaders should have adjusted the plan to the violent aftermath on the ground.

The panel before us notes that responsible leaders could have been more adaptive in the face of changing conditions and specifically identifies a number of such leaders in CJTF-7, the Coalition Forces Land Component Command, U.S. Central Command (CENTCOM), the Joint Staff, and the Office of the Secretary of Defense (OSD).

Although General Sanchez and the senior leaders of CJTF-7 were identified for leadership lapses, the panel also noted that CJTF-7 was never adequately resourced to meet the size and complexity of its mission and at one point had only 495 of the 1,400 personnel authorized.

Among the severe personnel shortages which they noted, MP detention units did not receive detention-specific training during their mobilization period. Training at the mobilization sites was inadequate. Deployment to Iraq was chaotic. Hand-over from the ongoing units in Iraq was too brief. There were major difficulties in training to their new mission once in country. They were not properly equipped for combat. Equipment, like Army-issued radios, were frequently inoperable and too few in number. Perhaps most significantly, according to our panel, there were insufficient MP personnel at Abu Ghraib resulting in a 75-to-1 ratio of detainees to MPs: 7,000 detainees to 92 MPs. In addition to all that imbalance, Abu Ghraib was under frequent mortar attack, thus adding a force protection task, and compare all that to the Guantanamo situation where there was a 1-to-1 ratio of detainees and the Army doctrinal ratio of 8-to-1.

To complicate things even further, Central Intelligence Agency (CIA) personnel used different interrogation techniques than those used by military personnel, and the CIA was allowed to keep the presence of detained personnel off the books so that the ICRC was not aware of those ghost detainees. Secretary Rumsfeld personally approved this practice on at least one occasion. A number of us earlier this morning, including the chairman, expressed to the panel our determination that we are going to get the CIA responses to these issues that have been raised about the fact that they kept detained personnel "off the books" in violation of the Geneva Conventions requirements.

Finally, the panel before us has reported on a number of significant questions which they do not purport to answer. They have raised them, they are very important ones, and they require an answer at some point.

For instance, did the Joint Staff or the OSD realize that there was a need to ensure that interrogation techniques specifically devised for Guantanamo were not being used in Afghanistan and certainly not in Iraq, and if not, why not?

Why did CENTCOM not ensure that there was separate guidance for detainee interrogations for Afghanistan and Iraq?

Why was the planned flow of forces to the theater of operations pursuant to the time phased force deployment list scrapped in favor of piecemeal unit deployment orders?

Why did CENTCOM approve CJTF-7 interrogation policies that apparently were based on an outdated version of the field manual which authorized interrogators to control all aspects of the interrogations?

Why did it take so long to finalize the joint manning document?
 Why did Secretary Rumsfeld agree to the use of military detention facilities in Iraq to house a ghost detainee at the request of the Director of Central Intelligence (DCI)?

Why did a senior member of the National Security Council (NSC) staff visit Abu Ghraib?

We thank this panel again. It has been a terrific service that they have performed for us. We look forward to their testimony.

Chairman WARNER. Thank you, Senator Levin.

Dr. Schlesinger?

**STATEMENT OF DR. JAMES R. SCHLESINGER, CHAIRMAN,
 INDEPENDENT PANEL TO REVIEW DEPARTMENT OF DE-
 FENSE DETENTION OPERATIONS**

Dr. SCHLESINGER. Thank you, Mr. Chairman.

Mr. Chairman, if I may, I would like to introduce James Blackwell, who was the executive director of the panel. Mr. Blackwell is a graduate of West Point. He is also the author of *On Brave Old Army Team*. As you may know, that was a study of ethical lapses in the athletic program at West Point in the early 1950s.

Chairman WARNER. We welcome you. Would you care to identify the others here with you, Dr. Brown?

Dr. BROWN. This is my assistant, Daniel Rankin.

Chairman WARNER. Mr. Rankin. Thank you very much.

Dr. SCHLESINGER. Thank you, Mr. Chairman, Senator Levin, members of the committee.

I will skip some of my testimony. I thank you for your complimentary references to our study. You have all obviously had a chance to read it, and since you have quoted it extensively, there is no need for me to summarize it. Instead I should like to place the details of a primarily descriptive report in a wider context and make some observations about some salient issues that may be overlooked. In a matter of this sort, it is important we not overlook the forest for the trees.

The focus of the panel and our primary concern should be the morale, the health, and the performance of our Armed Forces, I am sure that that resonates with the members of this particular committee, that those forces and their behavior uphold the standards that the American society believes appropriate. If there are any defects, they must be diagnosed and any infected areas must be lanced and cauterized as we seek to avoid repetition. In this manner, we can cleanse any stain on the reputation of our Armed Forces so that their overall performance continues to be understood and highly valued by the larger American society.

In this regard, we must continuously bear in mind that the overall performance, as the chairman mentioned, of these Armed Forces has been commendable. We must not lose sight of this fundamental reality which reflects both technology and a professional force. Through the advance of technology, we have been able to target enemy forces with precision. As a consequence, we sought in Iraq to preserve the infrastructure so that it could serve Iraq's future and also to successfully limit collateral damage. Moreover, we now have, by and large, a trained professional force. The vast majority of that force has behaved in Iraq with extraordinary forbearance

and including countless acts of kindness. In this respect, their performance has been vastly better than our performance in previous wars, World War II, Korea, and Vietnam. While we did not feel it necessary to spell this out in the report, in light of some of the public commentary, I can only say that it deserves emphasis and repetition. Our troops have performed well.

Bear in mind that we have had some 50,000 detainees and that over 300,000 of our troops have now served in Iraq. To be sure, any abuses are too many. But to date we have identified some 300 cases of possible abuse, of which fewer than 100 have been confirmed. One-third of those abuses have been at the point of capture. War is a matter of violence and in combat, passions run high.

The administration may have initially erred in characterizing the actions at Abu Ghraib as the result of a handful of MPs. Still in the overall performance, the 66 cases of confirmed abuse is a small number, comparing quite well, as I say, with previous wars. War remains a brutal business. Some critics reveal that they understand neither war nor history. We must not confuse the speed and extent of communication today with the extent of abuse as compared to the past.

The panel found no policy that encouraged or justified abuse and more than a few actions to avoid abuse. To be sure, given the initial act of terrorism on September 11 and the spurt in U.S. casualties in the summer of 2003, it was concluded that interrogation should be thorough and aggressive. In the war on terrorism, we would be naïve to limit ourselves to the traditional “name, rank, and serial number.” In the conditions of today, aggressive interrogation would seem essential.

Mr. Chairman, your remarks earlier about the chilling effect that might have developed as a result of the Abu Ghraib incidents is a point very well taken. The marines, for example, up in Fallujah no longer move on the basis of intelligence unless that intelligence can be confirmed, and as a result, they are missing opportunities to deal with some of the insurgents.

The injunction from the top, from the President, was to ensure humane treatment of detainees, even those who were judged outside the scope of the Geneva protection. Admittedly what constitutes humane treatment lies in the eye of the beholder. Some, including some in the Services, argued that aggressive interrogation went too far. Indeed, the revision of Secretary Rumsfeld’s initial memorandum that Senator Levin referred to was a result of protests that had come from Navy personnel. That remains a matter of judgment. It also remains a far cry from a policy that encourages abuse.

These issues and the public reaction have been exacerbated by the photographs taken on the night shift at Abu Ghraib. Those photos constitute, to say the least, an idiosyncratic and obviously unauthorized activity by that night shift. The photographs are quite misleading. In contrast to the inferences that some initially drew, those photographs have nothing to do with interrogation policy. None of the detainees abused in the photographs were targets of intelligence or of interrogation to gain intelligence. The latest development indicates that one of those photographs may have had to do with the pursuit of intelligence.

Nonetheless, abuses did occur at Abu Ghraib and elsewhere during interrogation. In such cases the MPs had been encouraged by MI personnel to use aggressive tactics. Those excesses must be identified and corrected to discourage any recurrence in the future. Such excesses may have resulted from confusion as to what was permissible. Some of that confusion may be understandable but not justified since we did have interrogation operations in three different places with varying rules. That created ambiguity. Nonetheless, in the future such ambiguity is unacceptable. A general policy should be designed and enshrined in doctrine so that military personnel are properly trained to observe appropriate rules.

Though abuses were indeed more widespread than observed on the night shift at Abu Ghraib, nonetheless it is correct to characterize the situation on that night shift as having its unique aspects. Some have seized upon the photographs to suggest that torture was condoned. This is simply wrong. The actions of the night shift on Tier 1 were an aberration. The members were off on their own. As one participant admitted, "we did it for the fun of it." I have characterized those activities by the night shift on Tier 1 as an "Animal House."

In this connection, President Kennedy said during the Cuban Missile Crisis that a picture is worth a thousand words. It clearly is if, and only if, one knows what the picture means. But if pictures are misinterpreted, they can readily become a distorting mechanism. That can easily create an inaccurate impression, hiding, indeed distorting the overall performance, as I have suggested with regard to our Armed Forces in Iraq.

Mr. Chairman, as your remarks and Senator Levin's remarks indicated, the panel's report delineated both errors of commission and errors of omission. But we found no indication of a policy encouraging abuse. To be sure, these abuses and the failed oversight that allowed them are an embarrassment. They do not reflect the standards that this society believes appropriate. We must take those steps necessary to see that those standards are, indeed, upheld in the future. Yet, we must not allow some of the trees to obscure the view of the entire forest. These actions, by historical standards quite limited in number, are not representative of the overall behavior of our forces, which has been generally admirable.

When sitting for his portrait, Oliver Cromwell ordered his portraitist, who wanted to pretty Cromwell up, that the portrait should include warts and all. Of necessity, our panel was charged to concentrate on the warts. Yet, Members of Congress must remain aware of the full portrait. I have tried to stress that a full portrait is more than those warts, which in our panel we were obliged to analyze.

Thank you very much, Mr. Chairman. I shall be happy to answer any questions that you may have.

[The prepared statement of Dr. Schlesinger follows:]

PREPARED STATEMENT BY DR. JAMES R. SCHLESINGER

Mr. Chairman, members of the committee: I am grateful to the committee for providing the opportunity to discuss the Panel's report on abuses at Abu Ghraib Prison and elsewhere. Secretary Rumsfeld established the panel to provide an independent and objective assessment of what had gone wrong in our detention operations, to review the other Department of Defense (DOD) investigations that were underway

for gaps, and to provide any recommendations and additional observations that were required. He added in his charge to us: "Let the chips fall where they may." We have striven to fulfill that mandate. In that effort, we have received the full cooperation of the DOD, which is already moving ahead in numerous areas with adjustments and reforms to prevent a recurrence.

We believe that we have provided a full and accurate, down to the time of publication, description regarding the extent of these abuses and how they came about—and what might be done in the future to reduce the risk of reoccurrence. Since the full report, including the Executive Summary, has been available for more than 3 weeks, I shall not attempt to summarize it here. Instead, I should like to place the details of a primarily descriptive report in a wider context—and make some observations about salient issues that may readily be overlooked. In a matter of this sort, it is important that we not overlook the forest for the trees.

1. Our focus and our prime concern should be the morale, health, and performance of our Armed Forces—and that their behavior upholds the standards that the American society believes appropriate. If there are any defects, they must be diagnosed and any infected areas must be lanced and cauterized—as we seek to avoid repetition. In this manner, we can cleanse any stain on the reputation of our Armed Forces—so that their overall performance continues to be understood and highly valued by the larger society.

2. In this regard, we must continuously bear in mind that the overall performance of those Armed Forces has been commendable. We must not lose sight of that fundamental reality, which reflects both technology and a professional force. Through the advance of technology, we have been able to target enemy forces with precision. As a consequence, we sought in Iraq to preserve the infrastructure, so that it could serve Iraq's future, and to successfully limit collateral damage. Moreover, we now have, by and large, a trained professional force. The vast majority of that force has behaved in Iraq with extraordinary forbearance, including countless acts of kindness. In this respect, their performance has been vastly better than in previous wars: World War II, Korea, and Vietnam. While we did not feel it necessary to spell this out in the report, in light of some of the public commentary, I can only say that it deserves emphasis and repetition. Our troops have performed well. Bear in mind that we have had some 50,000 detainees—and that over 300,000 of our troops have served in Iraq. To be sure, any abuses are too many. But, to date, we have identified some 300 cases of possible abuse of which fewer than 100 have been confirmed. One-third of those abuses have been at the point of capture. War is a matter of violence, and, in combat, passions run high.

3. The administration may have initially erred in characterizing the actions at Abu Ghraib Prison as the result of a handful of MPs. Still in the overall performance, the 66 cases of confirmed abuse is a small number—comparing quite well, as I say, with previous wars. War remains a brutal business. Some critics reveal that they understand neither war nor history. We must not confuse the speed and extent of communication today with the extent of abuse, as compared to the past.

4. The panel found no policy that encouraged or justified abuse—and more than a few actions to avoid abuse. To be sure, given the initial act of terrorism on September 11 and the spurt in U.S. casualties in the summer of 2003, it was concluded that interrogation should be thorough and aggressive. In the war on terrorism, we would be naïve to limit ourselves to the traditional "name, rank, and serial number." In the conditions of today, aggressive interrogation would seem essential. The injunction from the top was to insure "humane treatment" of detainees, even those who were judged outside the scope of Geneva protection. Admittedly, what constitutes "humane treatment" lies in the eye of the beholder. Some, including some in the Services, argued that aggressive interrogation went too far. That remains a matter of judgment. It also remains a far cry from a policy that encourages abuse.

5. These issues and the public reaction have been exacerbated by the photographs taken on the night shift at Abu Ghraib. Those photos constitute, to say the least, an idiosyncratic, and obviously unauthorized, activity by the night shift on Tier 1. The photographs are quite misleading. In contrast to the inferences that some initially drew, those photographs had nothing to do with interrogation policy. NONE of the detainees abused in the photographs were targets of intelligence or of interrogation to gain intelligence. Nonetheless, abuses did occur at Abu Ghraib Prison and elsewhere, during interrogation. In such cases, the MPs had been encouraged by MI personnel to use aggressive tactics. Those excesses must be identified and corrected—to discourage any recurrence in the future. Such excesses may have resulted from confusion as to what was permissible. Some of that confusion may be understandable, since we had interrogation operations in three different places with varying rules. That created ambiguity. Nonetheless, in the future such ambiguity is un-

acceptable. A general policy should be designed, and enshrined in doctrine, so that military personnel are properly trained to observe appropriate rules.

6. Though abuses were indeed more widespread than observed on the night shift at Abu Ghraib; nonetheless, it is correct to characterize the situation on that night shift as having its unique aspects. Some have seized upon the photographs to suggest that torture was condoned. That is simply wrong. The actions of the night shift on Tier 1 were an aberration. The members were off on their own. As one participant admitted: "We did it for the fun of it." I have characterized those activities by the night shift on Tier 1 as "Animal House."

7. In this connection, President Kennedy said, during the Cuban Missile Crisis, that a picture is worth a thousand words. It clearly is—if, and only if, you know what the picture means. But if pictures are misinterpreted, they can readily become a distorted mechanism. That can easily create an inaccurate impression; hiding, indeed distorting, the overall performance, as I have suggested with respect to our Armed Forces in Iraq.

Mr. Chairman, the Panel's report delineated both errors of commission and errors of omission. But we found no indication of a policy encouraging abuse. To be sure, these abuses and the failed oversight that allowed them are an embarrassment. They do not reflect the standards that this society believes appropriate. We must take those step necessary to see that those standards are, indeed, upheld in the future. Yet, we must not allow some of the trees to obscure the view of the entire forest. These actions, by historical standards quite limited in number, are not representative of the overall behavior of our forces, which has been generally admirable.

When sitting for his portrait, Oliver Cromwell ordered his portraitist, who wanted to pretty Cromwell up, that the portrait should include "warts and all." Of necessity, our panel was charged to concentrate on the warts. Yet, Members of Congress must remain aware of the full portrait. In these somewhat personal remarks, I have tried to stress that a full portrait is more than those warts, which in our panel we were obliged to analyze.

Thank you very much, Mr. Chairman. I shall be happy to answer any questions that you or other members of the committee may have.

Chairman WARNER. Thank you, Dr. Schlesinger.
Secretary Brown.

STATEMENT OF DR. HAROLD BROWN, MEMBER, INDEPENDENT PANEL TO REVIEW DEPARTMENT OF DEFENSE DETENTION OPERATIONS

Dr. BROWN. Thank you, Mr. Chairman. Mr. Chairman, Senator Levin, members of the committee, I am glad of the opportunity to appear before you today to give you my personal conclusions and to report on the work of the independent panel, conclusions on the issues involved. Some related investigations, some in the DOD, one outside, are still in progress, and further facts may well emerge. So a degree of tentativeness remains, but the panel's own work and our access to almost all the other investigations have revealed enough so that conclusions, if not final ones, can be drawn. I hope that unlike the case of Oliver Cromwell who was dug up after the restoration and hanged, you will not have to go through the same process with us. [Laughter.]

The abuses in Tier 1 at Abu Ghraib Prison displayed a pathology not, so far as we were able to find, duplicated elsewhere. But as has been pointed out by several of you, there have been several hundred other cases of abuse of detainees that have been alleged at Abu Ghraib Prison and elsewhere in Iraq and Afghanistan and Guantanamo, a significant fraction confirmed, and a third appear to have been connected with interrogations. These, of course, are completely unacceptable on humanitarian grounds, but in addition, those events have been extremely damaging to U.S. standing, policies, and objectives in the Greater Middle East and to the struggle

against transnational terrorism, as well as to the image and self-image of the Armed Forces and of America itself.

The underlying context for abuses was framed by two judgments made before combat operations began in Iraq and indeed Afghanistan. First, the DOD leadership, along with much of the rest of the administration, expected that following the collapse of the Saddam Hussein regime through coalition military operations, a stable successor regime would soon emerge in Iraq. Now, there was planning for some contingencies, but as Senator Levin noted, those plans did not include planning for what actually happened: a breakdown of order, widespread looting and infrastructure destruction, strong resistance to the occupation. In turn, and this had a direct impact on the abuse situation that produced a large, mixed population of detainees, Baathist holdouts, high level officials, surrendered military, domestic and foreign religious extremists, ordinary criminals, individuals captured in the act of attacking coalition forces or suspected of doing so, and undoubtedly some innocents, maybe many innocents. That was what happened rather than what was expected, which was a relatively large number of relatively passive prisoners of war. Furthermore, the detention operations took place within a situation that is a more serious product of the misjudged forecast of what would happen after the overthrow of the Saddam regime. Iraq, including urban areas, remained and remains a zone of continued and substantial combat, as well as economic deprivation and political instability.

The second judgment was embodied in the policy adopted toward various classes of detainee, set for al Qaeda and Taliban after September 11, following debate within the U.S. Government and decision by the President. The President determined that the provisions of the Geneva Conventions did not apply to our conflict with al Qaeda, that Taliban detainees were unlawful combatants not qualifying as prisoners of war. I think that was a reasonable judgment. Furthermore, the President reaffirmed a previous order by the Secretary of Defense that all detainees be treated humanely and, to the extent appropriate and consistent with military necessity, in a manner consistent with the Geneva Conventions principles.

Now, that process led, in turn, to a series of determinations about allowed interrogation methods beyond those long customary under Army Field Manual (FM) 34-52. As Senator Levin pointed out, the Secretary of Defense authorized and then rescinded a list of such methods for Guantanamo. After study by a working group that was headed by the Air Force General Counsel, he promulgated a narrowed-approved list, again limited to interrogations of unlawful combatants held at Guantanamo. These events occurred before operations took place in Iraq.

We did not find any evidence of a policy on the part of senior civilians or military authorities that countenanced, let alone encouraged or directed, abuse. Approval of interrogation techniques beyond those in the Air Force Manual was limited to Guantanamo. It required that any of them be used only with the specific approval of the Secretary of Defense in each case. He approved any of them in only two cases, and those additional methods of interrogation, which were not torture, by the way, but they were more permissive

than Army FM 34–52, were intended for and limited to resistant al Qaeda members at Guantanamo knowledgeable about what had been their plans for September 11 and for the future, and they were productive.

All that said, nevertheless, various versions of expanded lists migrated, unauthorized, to Afghanistan and to Iraq where the Geneva Conventions continued to apply, according to the President's decision, except for foreign terrorists—that is, foreign to Iraq. That migration of rules and of personnel led to confusion about what interrogation practices were authorized and to several changes in directions to interrogators. I believe that was a contributing factor in the abuse of detainees. Whether the initial, more expansive, approach adopted during the working group that the Secretary of Defense convened or whether the findings of the OLC in the DOJ, some of which I consider over the top, further contributed to an atmosphere of permissiveness in the field is more difficult to assess. It is a matter of psychological influence rather than of direction.

A result of the first misjudgment, especially at Abu Ghraib, was a situation in which both MP capabilities for custody and protection and MI capabilities for interrogation to obtain tactical, strategic, and counter-terrorist intelligence, suffered extreme lack of resources. Another result, as I mentioned, was that the mix and number of detainees went far beyond what had been planned for. The respective responsibilities, authorities, and modes of cooperation for military police and military intelligence units were poorly defined, and separately, the policy failure at all levels to assure a clear and stable set of rules for treatment and interrogation further opened the door to abuse. The problems were compounded by inadequate training, confused command arrangements, and at Abu Ghraib personal deficiencies at command levels up to and including the brigade level.

Now, it is always easy in hindsight—too easy—to assign blame. Nevertheless, varying degrees of responsibility for failure to provide adequate resources to support the custodial and intelligence requirements throughout the theater and for the confusion about permissible interrogation techniques extend all the way up the chain of command, to include the Joint Chiefs of Staff and the OSD.

Now, the report is considerably more detailed about why, how, and when abuses occurred and lessons learned. We gave about a dozen, I guess 14 or so, recommendations to improve the way we deal with such matters. Action on some of them is already underway. The DOD does do well at facing up to and correcting its mistakes.

The report notes, as has Secretary Schlesinger, that although any abuse of detainees is too much, these cases were only a small percentage of the tens of thousands of prisoners and detainees. In many cases, I should point out, they were brought to light by American military personnel who spoke up. As we look forward, the kind of conflict we are engaged in poses difficult problems of many kinds, detention and interrogation among them. The U.S. needs to deal with them more effectively. I hope that our report helps in that effort.

Thank you for your indulgence, Mr. Chairman. I will be prepared to answer questions.

[The prepared statement of Dr. Brown follows:]

PREPARED STATEMENT BY DR. HAROLD BROWN

Mr. Chairman, Senator Levin and members of the Committee: I am pleased to appear before you today to report on the work of the Independent Panel and to present my personal conclusions on the issues involved. Let me begin by noting that some related investigations are still in progress and that further facts may well emerge. That means that a degree of tentativeness remains. But the panel's own work and our access to almost all of the other investigations have revealed enough so that conclusions, if not final ones, can be drawn.

The abuses in Block 1A at Abu Ghraib Prison displayed a pathology not, so far as we were able to find, duplicated elsewhere. But there have been several hundred other cases of abuse of detainees alleged at Abu Ghraib and elsewhere in Iraq, in Afghanistan and at Guantanamo; a significant fraction have been or will be confirmed as such. About a third of the cases appear to have been connected with interrogations. In addition to their unacceptability on humanitarian grounds, these events have been extremely damaging to U.S. standing, policies and objectives in the Greater Middle East and to the struggle against transnational terrorism, as well as to the image and self-image of the Armed Forces and of America itself.

The underlying context for abuses was framed by two judgments made before combat operations began. First was the expectation by the Defense Department (DOD) leadership, along with most of the rest of the administration, that following the collapse of the Saddam Hussein regime through coalition military operations, a stable successor regime would soon emerge in Iraq. Though there was planning for some contingencies, those planned for did not include what actually happened; a breakdown of order, widespread looting and infrastructure destruction and strong resistance to the occupation. This, in turn, produced a large mixed population of detainees—Baathist holdouts; high level officials; surrendered military; domestic and foreign religious extremists; ordinary criminals; individuals captured in the act of attacking coalition forces or suspected of doing so; and undoubtedly some innocents—rather than a large number of relatively passive prisoners of war. Moreover, detention operations took place within a situation that is a more serious product of the misjudged forecast of what would happen following the overthrow of the Saddam regime: Iraq, including urban areas, remained (and remains) a zone of continued and substantial combat, as well as economic deprivation and political instability.

The second judgment was the policy adopted toward various classes of detainee, set for al Qaeda and Taliban after September 11, following debate within the U.S. Government and decision by the President. The President determined that the provisions of Geneva did not apply to our conflict with al Qaeda, that Taliban detainees were "unlawful combatants," not qualifying as prisoners of war, but reaffirmed a previous order by the Secretary of Defense that detainees be treated humanely and, to the extent appropriate and consistent with military necessity, in a manner consistent with the Geneva principles. This, in turn, led to a series of determinations about allowed interrogation methods beyond those long customary under Army Field Manual (FM) 34-52. The Secretary of Defense authorized, then rescinded, a list of such methods for Guantanamo and, after study by a working group, promulgated a narrowed approved list "limited to interrogations of unlawful combatants held at Guantanamo." These events occurred before operations took place in Iraq. We found no evidence of a policy on the part of senior civilian or military authorities that countenanced, let alone encouraged or directed, abuse. Approval of interrogation techniques beyond those in Army FM 34-52 was limited to Guantanamo and required that any of them be used only with the specific approval of the Secretary of Defense in each case. He approved any of them in only two cases. Those additional methods of interrogation were intended for and limited to resistant al Qaeda members at Guantanamo knowledgeable about what had been their plans for September 11 and for the future.

Nevertheless, various versions of expanded lists migrated unauthorized to Afghanistan, and to Iraq where the Geneva Conventions continued to apply. That migration of rules, and of personnel, led to confusion about what interrogation practices were authorized and to several changes in directions to interrogators. I believe that was a contributing factor in the abuse of detainees. Whether the initial, more expansive, guidelines or the findings of the Office of Legal Counsel (OLC) in the Department of Justice (DOJ) further contributed to an atmosphere of permissiveness in the field is more difficult to assess.

A result of the first misjudgment was, especially at Abu Ghraib Prison, a situation in which both Military Police (MP) capabilities for custody and protection, and Military Intelligence (MI) capabilities for interrogation to obtain tactical, strategic and counterterrorist intelligence, suffered extreme lack of resources. Another result was that the number and mix of detainees went far beyond what had been planned for. The respective responsibilities, authorities and modes of cooperation for MP and MI units were poorly defined. Separately, the policy failure at all levels to assure a clear and stable set of rules for treatment and interrogation further opened the door to abuse. The problems were compounded by inadequate training, confused command arrangements and, at Abu Ghraib, personal deficiencies at command levels up to and including the brigade level. Hindsight always finds it too easy to assign blame. Nevertheless, varying degrees of responsibility for failure to provide adequate resources to support the custodial and intelligence requirements throughout the theater, and for the confusion about permissible interrogation techniques, extend all the way up the chain of command, to include the Joint Chiefs of Staff and the Office of the Secretary of Defense.

Our report goes into considerably more detail about why abuses occurred, how they occurred and lessons learned. It includes a dozen or so recommendations to improve the way we deal with such matters. Action on some of these is already under way. It also notes that, though any abuse of detainees is too much, these cases were only a small percentage of the tens of thousands of prisoners and detainees in the theater of combat, and that in many cases they were brought to light by American military personnel who spoke up. This new sort of conflict poses difficult problems of many kinds, detention and interrogation among them. The U.S. needs to deal with them more effectively. I hope that our report helps in that effort.

Chairman WARNER. Thank you very much. I called you Secretary Brown. My recollection is when I went to the Pentagon in 1969, you were still there as Secretary of the Air Force, were you not?

Dr. BROWN. Yes. I hung on for about 6 weeks. [Laughter.]

Chairman WARNER. I remember that very well, and I had the privilege of serving under Dr. Schlesinger when he joined the Department. I had a marvelous opportunity to know both of you and learn from you through these many years of association.

Dr. Schlesinger, I listened very carefully as Secretary Brown talked about his concern as to the impact of this series of incidents and the ongoing investigations on our Nation's credibility abroad as it relates to security matters and foreign policy. I think the record should reflect your views on that because you have had a wide knowledge of that sphere of responsibility in your many undertakings.

Dr. SCHLESINGER. There are peoples and nations that do not like the United States very much. Understandably that has increased since the end of the Cold War, since during the Cold War, most of them were more terrified by the Soviet Union. Now we are alone and we have become a more natural target for others. It does not seem to me that these events have altered significantly the view of the United States as portrayed by Al Jazeera, for example. It does not matter very much what we do. We will be given a very unsatisfactory report on Al Jazeera.

In the case of our splendid performance during the war in precision targeting and holding down the number of victims of collateral damage, none of this was conveyed on Al Jazeera. All they did was to show the destruction that did occur. So there is a lack of nuance in that case.

We also have some opponents in Europe. I do not believe that much of the European press is going to change its attitudes toward the United States. What this event does is to provide different and perhaps additional fuel to the fire of those who are anti-American. As I indicated in my comments, our responsibility and I think the

responsibility of this committee is to make sure that the health and performance of the United States Armed Forces survive this particular incident.

Chairman WARNER. I think to the extent that we may have had some temporary degradation, it will be remedied by the manner in which the administration has done these very thorough and pragmatic series of investigations, and hopefully as Congress addresses it and there is a suitable accountability established at the end. So I thank you.

Do you want to say something further?

Dr. BROWN. I think that Secretary Schlesinger is right, that the people who do not like us would not have liked us in any event. This has given them a stick to beat us with, which is not a good thing to give them. As you point out, some of our remedial efforts may provide us with something of a shield against that stick.

Chairman WARNER. Surely. I think we can recover from it.

Dr. SCHLESINGER. May I add, Mr. Chairman, that these episodes of abuse are very few in number, even though they are more extensive than the handful of people at Abu Ghraib Prison. However, people tend to focus on symbolic events, and as Joseph Stalin said at Potsdam: "one death is a tragedy, a million deaths are a statistic." Part of our problem here is that we have something that is very confined but has been portrayed as representative.

Chairman WARNER. You found that there were violations of the Geneva Conventions regarding failures to account for some detainees called the ghost category. This committee is going to undertake, presumably in conjunction with the Intelligence Committee, an examination of that issue. Were you able to get sufficient information when requested from the CIA on this matter?

Dr. SCHLESINGER. We did not receive sufficient information, and therefore we recommend in our report that the relationship between the CIA and the DOD be better defined in the future.

Chairman WARNER. Now, looking at your report, you are very specific on page 47. The CJTF Deputy Commander, that is General Wojdakowski, failed to initiate action to request additional military police and so forth. Then you addressed the CJTF C-2. That was General Fast. Then you addressed a colonel. You did not include General Karpinski in that recitation. My question to you is, what do you think the appropriate action should be other than initiating under the UCMJ the appropriate investigation?

Dr. SCHLESINGER. Assessing blame, providing judgments as to punishment was specifically excluded from our mission.

Chairman WARNER. Correct.

Dr. SCHLESINGER. The Secretary said leave that to the UCMJ.

Chairman WARNER. To him personally, I would presume, as the UCMJ works through its course of actions.

Dr. BROWN. General Karpinski gets her own paragraph.

Chairman WARNER. I saw her own paragraph a little later. I just wondered why she was not in that particular paragraph.

As you look at the series of investigations, it is incumbent upon this committee in our oversight capacity to determine if the full range of investigations probed all of the needed areas. Have you found any gaps in the investigations thus far that you could bring to our attention?

Dr. SCHLESINGER. No, sir. I think that those investigations have been thorough with respect to the DOD which was also our charge. As you indicated, it did not cover anything of other government agencies.

Dr. BROWN. Some of the investigations are not finished yet.

Chairman WARNER. That is correct.

Dr. BROWN. So it is premature to exercise a negative judgment—that gaps exist—which, in any event, I think is not justified.

Dr. SCHLESINGER. Admiral Church's investigation I think will be the culmination.

Chairman WARNER. Yes, we look forward to receiving that. I presume that the DOJ will perform such investigation as needed with regard to non-military allegations.

Senator Levin.

Senator LEVIN. Thank you. Again, my thanks to both you and to the colleagues that helped produce this report.

Chairman WARNER. Just a minute, Senator Levin. A vote is in progress. The time has expired. So I expect that we will have to take a brief recess here. We will come back as quickly as possible. [Recess.]

I think we will continue. We will await Mr. Levin's return, but in the meantime, is there a colleague on the other side that would proceed? Mr. Lieberman, why do you not proceed in Mr. Levin's place at this time?

Senator LIEBERMAN. Did you ask questions before?

Chairman WARNER. Yes, I have asked my questions.

Senator LIEBERMAN. Okay.

I thank our two witnesses for their service. I regret that I broke early to go to vote, so I did not hear Senator Warner's questions. So I apologize if there is any overlap.

I am interested in the numbers that both Senator Warner and Mr. Schlesinger talked about and just want to clarify a little. If you take the cases in which there are allegations of abuse and then go to the confirmed cases of abuse, it comes to a fraction of 1 percent of the detainees. I want to get the universe clear for the record, the detainees in Iraq, Afghanistan, and—or is that it? The 50,000 number.

Dr. SCHLESINGER. 50,000 is the total.

Senator LIEBERMAN. Is it Iraq and Afghanistan?

Dr. BROWN. And Guantanamo.

Senator LIEBERMAN. And Guantanamo.

Dr. BROWN. Over time.

Senator LIEBERMAN. Over time, understood.

Let me also understand, if I can, this other interesting question which is the percentage of the cases of abuses, either alleged or confirmed, maybe it is easier to do confirmed and more relevant, that were in cases related to intelligence, trying to get intelligence out of the detainees. Is there a number on that?

Dr. BROWN. About a third.

Senator LIEBERMAN. About a third of the confirmed abuse cases. Does that mean that the other cases of abuse were with civilian detainees or might they be military detainees who nonetheless were not targets of interrogation for intelligence purposes?

Dr. SCHLESINGER. They might be, sir.

Senator LIEBERMAN. I did not hear you.

Dr. SCHLESINGER. They might be, sir.

Senator LIEBERMAN. Okay, and let us focus specifically. So that the others would be either military who were not targets of an intelligence interrogation or just plain criminals who were in there.

Dr. SCHLESINGER. Yes, sir. Most of those photographs that you saw involve criminals.

Senator LIEBERMAN. That is what I wanted to ask. Can you give any more detail about that in terms of numbers of those we see in the photographs, that we have all seen and have now become very public in Abu Ghraib Prison? Were most of those not subjects of interrogation?

Dr. SCHLESINGER. Right, absolutely.

Dr. BROWN. All but perhaps one.

Senator LIEBERMAN. All but perhaps one. I am sorry. One of you testified to that. What is the judgment you reached or conclusion you reached about what the motivation was for the abuse we see? If it was not to get intelligence-relevant information out of the detainees, why were the dogs put on them, why were they held on leashes, why were they asked to strip?

Dr. SCHLESINGER. In some cases just pure sadism. I think that it was sadism primarily, but also I think Senator Levin referred to the fact that the MPs had been encouraged by the MIs, and one of the things that they were encouraged to do was to strip the prisoners.

Dr. BROWN. Some of it is misplaced attempts at maintaining discipline, of the same kind that occurs in civilian prisons.

Senator LIEBERMAN. Right.

Let me go to a different subject, General Kern this morning made a statement, and I wanted to ask you to respond to it because there are obviously questions here about how this happened, even though it is a very small number, a fraction of 1 percent of the detainees, and interestingly to me a fraction of those who were the targets of intelligence interrogation. But the phrase was used both publicly and earlier again today that people higher up the chain of command could be considered responsible but not culpable. These are not your words. They are his. I was not able to be here to ask him about what he meant. But does that express what you have said or does it go further than you want to say about how you would describe, I do not want to use the word "responsibility," the relevance of people higher up the chain of command to the abuses that you saw? Secretary Brown.

Dr. BROWN. Yes, it varies with the level. As you go up the level of command, an individual may not have taken any action that deserves punishment, but nevertheless be responsible because it happened under his command. Take the highest level, take for example the level of the Secretary of Defense. I do not think that you can punish somebody, demand resignation on the basis of some action, an individual action by somebody far down the chain. I think at that level the decision has to be made on the basis of broad performance, and indeed at the very highest level, it is made at election time.

Senator LIEBERMAN. Yes, indeed.

This is really a question of if you saw some, to use a frame of reference from another place, sins of omission as opposed to commission, and you both have been heads of this Department. How do you make a judgment about how to hold people accountable? Clearly, in this and so many other cases, there has been more accountability here than in other cases so far, but at a lower level. How do you decide when the interest in holding people accountable is outweighed by other public interests? I guess that is the general question that I raise.

Dr. BROWN. I do not think that is ever the case. I do not think the interest of holding people accountable is outweighed by the public interest. I think at many levels it is a question of criminal prosecution, and that is in train. That is in process. At higher levels, it is a question of failure to perform duty and you deal with that differently. At a still higher level, you can raise the question of what kind of atmosphere was produced. But it seems to me that is a different kind of accountability, and that is where you can perhaps separate it from culpability.

Dr. SCHLESINGER. If one is not aware, that is, even though one might have had the opportunity to be aware, that is not culpable in my judgment. It is when one has a concrete decision to make. For example, when General Sanchez put together his first list of acceptable techniques and sent it to CENTCOM, CENTCOM said this is impermissibly aggressive and sent it back for correction. In that case I think that CENTCOM was acting correctly.

Senator LIEBERMAN. My time is up. Thank you very much.

Dr. SCHLESINGER. Can I throw in a couple of comments?

Chairman WARNER. Yes, go ahead, Dr. Schlesinger.

Dr. SCHLESINGER. Of the 66 cases, or the so-called 66 cases, 24 of them are serious. The others are less serious. That 66 has now been dropped to 65 cases of abuse. Why? Because one of the alleged cases of abuse was of an Iraqi prisoner throwing a cup of water at a guard and the guard, who was holding a cup of water, threw his cup of water at the prisoner. That was first regarded as an abuse and then it was decided that it did not rise to the level of abuse.

Senator LIEBERMAN. We do that around here all the time. [Laughter.]

Thank you very much.

Chairman WARNER. Thank you.

Senator McCain.

Dr. SCHLESINGER. No one monitors Senators' operations of that sort, Senator. [Laughter.]

Senator MCCAIN. I want to thank the witnesses for the excellent work. Secretary Schlesinger, this morning I introduced your piece that was in the Wall Street Journal as part of the record, and I think it is important to maintain a proper balance as we go through this investigation, which was clearly the intent and effect of your piece.

But I would like to get back a little bit to the line of conversation that you were having with my friend, Senator Lieberman. There is accountability but there is also responsibility. Now, I read through the report here. As you just referred to, General Sanchez, on advice of his staff, issued guidelines which were later rescinded, one of which was the presence of military working dogs. You go on to say,

“compounding these problems was the inadequacy of leadership, oversight, and support needed in the face of such difficulties.” That is on page 10.

Then you go on to say on page 13, “the aberrant behavior on the night shift in cell block 1 at Abu Ghraib would have been avoided with proper training, leadership, and oversight.”

You go on to say on the bottom of page 14, “CENTCOM disapproved, but things were left out of the CJTF-7 policies and were corrected by.” This clearly led to confusion on what practices were acceptable. We cannot be sure how much of the number and severity of abuses would have been curtailed had there been early and consistent guidance from higher levels. Nevertheless, such guidance was needed and likely would have had a limiting effect.

Finally on page 15, you say, “We believe Lieutenant General Sanchez should have taken stronger action in November when he realized the extent of the leadership problem at Abu Ghraib. Major General Wojdakowski and the staff should have seen that urgent demands were placed on higher headquarters. Lieutenant General Sanchez and Major General Wojdakowski failed to ensure proper staff oversight of detention and interrogation problems.”

Now, I understand they were fighting a war and I understand their responsibilities, as one of the generals this morning stated. But this series of events has had a huge effect in the Arab world and around the world. So my question to you is, is there not some accountability? Is there not some responsibility here for a series of events which had profound impact, as I say, throughout the world and not to mention egregious violations in many respects of basic human rights, of which this Nation has always been the leader on? Let us talk about responsibility.

Dr. SCHLESINGER. I think that it is quite clear that when General Sanchez signs that document and then ships it to CENTCOM for approval, that he is responsible for his signature. Now, it may be that General Sanchez, who was seriously understaffed, just signed a document that was put together by his staff, but he is still responsible for that document. That goes for the revised edition as well.

I think that, for example, Colonel Warren, who when he was away on leave. We comment that there seemed to have been extraordinary frequency of vacations during this period on that staff. When Colonel Warren was away, the ICRC critique came in. He was away. When he came back, he looked at the critique by the ICRC. He said that he did not regard it as credible or believable, and he did not convey that to General Sanchez. That was an action for which he has a responsibility, and in his interview with us, he said, “that is what I will carry to my dying day as my failing.”

Senator MCCAIN. I guess my point here is that there is some belief that the only thing that went wrong was a group of enlisted people that were guilty of aberrant behavior late at night.

Dr. SCHLESINGER. I think we have gone beyond that.

Senator MCCAIN. Okay. Now, if there are people responsible—and I would want to be very careful—are they not held responsible? Is there some action? Is there something besides a report, as important as it is? I am not trying to—

Dr. SCHLESINGER. They should be and these are being processed under the UCMJ.

Dr. BROWN. Some of them have legal culpability.

Senator MCCAIN. Yes. I am not talking about UCMJ here, Dr. Schlesinger.

Dr. BROWN. Some of them have legal culpability. At other levels, believe me, I am convinced careers will be negatively affected. That is a consequence of responsibility that is seen as having been inadequately addressed.

Senator MCCAIN. I just want to clear that up because it seems to me that I do not think that any individual in positions of higher command would be liable particularly for UCMJ. But I do not think that is the standard by which we judge leadership, not whether they violate the UCMJ or not.

I thank you both for a very helpful document and one which I think is a very important one, and I appreciate it.

I thank you, Mr. Chairman.

Chairman WARNER. Senator McCain, you framed a series of questions here as it related to General Sanchez, and I wanted to give Dr. Schlesinger once more an opportunity, if you so desire, to more fully respond to very carefully selected portions of your report which reflect less than the highest standards of professional judgment.

Dr. SCHLESINGER. Two initial observations. First, as Dr. Brown indicated or hinted, General Sanchez likely would have gotten his fourth star and now is unlikely to get his fourth star. That is a kind of comment on failed responsibility. That is quite clear.

Second, there are extenuating circumstances.

Chairman WARNER. In his case, very definitely.

Dr. SCHLESINGER. In his case, because he had only one-third of the complement that a corps commander had. He was a major general in charge of a division. He suddenly becomes a corps commander and he is left essentially with a division staff. So I think that, yes, there was a failure of responsibility in that but being shorthanded in part explains that.

Chairman WARNER. Then I think Secretary Brown used the phrase, you have to look at the full, broad range of everything this one individual was asked to do. We had him before this committee and I think he very commendably acknowledged that there were things, that if he had time, maybe adequate staff, he would have done differently.

But I just want to give you the full opportunity.

Now, there it is not a UCMJ situation. It is left to the Secretary of Defense. Am I correct in that instance?

Dr. SCHLESINGER. Yes.

Chairman WARNER. I think that could well be in other instances here. He, as we well know, recognized the responsibility of command, so to speak, on the civilian side and accepting responsibility for those below you, your subordinates, who take actions which are not in the best interest of sound professional judgment. Am I correct in that?

Dr. SCHLESINGER. May I throw in something here, Senator?

Chairman WARNER. We are not trying to fish.

Senator MCCAIN. Could I make one additional comment that I think has to be taken into consideration?

Chairman WARNER. Yes.

Senator MCCAIN. I happen to believe from some personal encounters that there were enormous pressures that were brought to bear on the command in Iraq to get better intelligence information because of the increase in deaths, and that pressure is something I do not think we will ever be able to define or track down, but I am convinced that it was there. I would like you to comment on that as well.

Dr. SCHLESINGER. Absolutely, there was psychological pressure. I do not think any senior official suggested that in order to do this, take these kinds of actions, but there was no doubt psychological pressure as that spurt in U.S. mortalities rose in the summer of 2003.

Chairman WARNER. Mortalities and personal injuries. There was an enormous number of injuries.

Dr. SCHLESINGER. If I may interject something. We may have to reexamine existing doctrine. Existing Army doctrine says that commander is responsible for his entire area of responsibility (AOR). We give General Sanchez the responsibility of fighting a war. Suddenly he is elevated. In addition, he is supposed to take care of detention operations. It seems to me that we might reexamine that and have a unit that is different that handles detention and that is responsible for detention and not impose it on a fighting commander simply on the belief that he should be responsible for everything in his AOR.

Chairman WARNER. Senator Levin, I thank you for your patience. We missed you on the first round.

Senator LEVIN. There is no problem.

On the accountability issue, there is a great deal of confusion about what the legitimate methods of interrogation were. You pointed this out in detail in your report. You have a statement that your report makes that when General Sanchez approved interrogation techniques that included a dozen techniques beyond those authorized by Army FM 34-52 and five beyond those approved for Guantanamo, he used the reasoning, in your words, from the President's memorandum of February 7, 2002.

Now, in what way did he use that reasoning?

Dr. SCHLESINGER. As I recall it, Senator, and I can be corrected on this, his judgment and perhaps the advice that he received was that as the commander in the field, he had that inherent authority to expand beyond the list that FM 34-52, expand beyond the list that the Secretary of Defense had used.

Dr. BROWN. An analogy may have been drawn with the finding of the OLC that the President, acting as commander in chief, cannot be challenged anywhere, a view that I think might not find a strong resonance in this body.

Senator LEVIN. Not only in this body, but I would hope in much of the civilized world.

Is that the reasoning you referred to in the President's memorandum, that the commander in chief has great flexibility, can do no wrong? Is that what you are referring to?

Dr. SCHLESINGER. As a combatant commander, he had the inherent authority to make those decisions on his own and he was aware of higher level authorization.

Senator LEVIN. I want to pin it down, though. But that reasoning you are saying you attribute to the reasoning in the President's memorandum of February 7.

Dr. BROWN. It is an analogy. Whether that in fact was his reason is not clear.

Senator LEVIN. All right. So you did not get an explicit statement from him that he is using the same reasoning in his.

Dr. BROWN. No.

Senator LEVIN. You are analogizing the reasoning.

Dr. BROWN. That is correct.

Dr. SCHLESINGER. I think that that was the explanation that we received from Colonel Warren who asserted that the combatant commander had this inherent authority in his judgment.

Senator SESSIONS. Mr. Chairman, I believe that is the Colonel Warren that testified here before us so ably. Was it not?

Chairman WARNER. He was present at a previous panel.

Senator SESSIONS. A very impressive officer and under a lot of pressure. He explained the situation here in a confused hearing. He just brought clarity to the whole picture that we had never seen before.

Dr. SCHLESINGER. He was very impressive in our interview. As I say, on the issue of the ICRC, he said, "I shall carry that with me till the end of my life."

Chairman WARNER. Having accepted responsibility for failing to do his duty.

Dr. SCHLESINGER. Yes.

Senator LEVIN. I do not know what accepting responsibility means if it does not mean accountability. Hey, I have heard people accept, at this table, responsibility for everything. I have heard George Tenet accept responsibility for all the intelligence failures, but nothing follows from it. The question is, what follows? Where is the accountability? That is what I want to get to next.

Dr. BROWN. There is more than one kind of penalty, Senator Levin.

Senator LEVIN. That is true. But we are talking, really, about accountability. One way or another it is accountability. It is not just a general "I accept responsibility" because that does not do anything. Those are just words. That is rhetoric.

Now, your panel also found that there was not only a failure to plan for a major insurgency, but to quickly and adequately adapt to the insurgency that followed. Now, what is the source of the failure to plan for the major insurgency? What is the source of that failure, in your words? Where did that come from?

Dr. BROWN. My own judgment is that there was, in the DOD, including the OSD, and in some but not all other parts of the Government, a belief that we would be welcomed as liberators and that there would be an easy transition.

When you believe that, you do not plan for some kinds of things.

Dr. SCHLESINGER. May I add to that? The plans did include an expectation of "some resistance," but nobody anticipated the extent of a major insurgency.

They did plan for some other things. They planned for sectarian fighting, followed by large numbers of refugees, attacks on the oil-producing facilities. Those were not what happened.

Senator LEVIN. So that failure goes back to the basic plan that there would not be any major problem after the major operation was finished. That then becomes the source of great problems, the failure to plan that.

Dr. SCHLESINGER. Not that there would not be a major problem. That there would not be a major insurgency.

Senator LEVIN. Major insurgency. Thank you.

There is also here, in your words, a failure to quickly and adequately adapt to the insurgency that followed. What is the source of that failure? Who is accountable for that failure?

Dr. BROWN. That accountability, it seems to me, extends up to the higher headquarters because they did not provide the additional resources that the new situation demanded. Now, to what extent the people down below did not ask hard enough and to what extent the ones up above were not responsive enough, that I think has to be sorted out. We could not do that.

Dr. SCHLESINGER. Let me throw in something here, Senator. Some of the military took the view that security is not our responsibility. That was plainly seen in the early days. The reality is that security is the heart of the problem in the post-attack period, and as a consequence, the early-on adaptation should have recognized, in my judgment, that only trained Iraqis could provide security, that the United States would not have the intelligence, it was not aware of the culture. We should have started from day one to create the necessary Iraqi security forces. That was a long lag.

Senator LEVIN. Just to tie this up, and this will be my last question. You just made reference to it, I believe it was Dr. Brown, about reluctance to ask for additional forces because your report does make reference to the possibility, at least, that there was a reluctance on the part of the Joint Task Force to submit a request for forces for MP units. There is no evidence, you say, that any of the responsible officers considered any option other than the response given to Brigadier General Karpinski to "wear her stars" and reallocate personnel among her already-overstretched units. In other words, she apparently did ask for additional people and was told—am I correctly reading your report?

Dr. BROWN. She asked the wrong person.

Dr. SCHLESINGER. She was not in that chain of command.

Senator LEVIN. Who told her to "wear her stars?"

Dr. SCHLESINGER. When she talked to the people at CJTF-7.

Senator LEVIN. She did ask someone at CJTF-7 for additional people and they said, "wear your stars," reallocate personnel. That is their answer?

Dr. SCHLESINGER. That is correct, but the request should have gone to General McKiernan who was in charge of General Karpinski.

Senator LEVIN. The response, though, is interesting. It was not, "you went to the wrong place, go over there." It was, "wear your stars, reallocate your people." There is something improper about asking for more personnel. That is the whole implication here. So you are understaffed and, oh, hey, I understand that. Go over there

to ask. That is not what she hears. It is rather make do with what you got. That is a big problem which your report has suggested, it seems to me.

Dr. SCHLESINGER. If they were understaffed at Abu Ghraib, if there were other military police within country that could have been reallocated, I think that that was the intent of the advice to General Karpinski.

Senator LEVIN. Thank you.

Chairman WARNER. Thank you.

Colleagues, our colleague here from Oklahoma has to depart.

Senator INHOFE. Just for a unanimous consent request. I thank you very much. I am not going to jump in front of you here. I took quite a bit of time this morning.

I think it needs to be in the record someplace that prison life is not easy. It is a tough thing, and here in the United States we have very serious problems. When I look at the results of your study and combine that, as I did this morning, with other studies that have taken place, such as 44 incidents of non-interrogation abuses in a prison population of 7,000, that is remarkable. We are talking about a half of 1 percent.

What I want to submit for the record is a very interesting article that compares prison abuse in America to be somewhere around 14 percent of the prison population are abused, either raped or beaten or injured in other ways. It goes on to graphically talk about some of the prisons, Mr. Chairman, in Virginia's Red Onion prison and the Wallens Ridge prison, talking about using stun guns and shot-guns loaded with rubber pellets to control prisoners. In Massachusetts, it graphically talks about some of the things that happened.

So I think it is appropriate to have, as a part of the record at this point, that the incidence of abuses in our prisons in the United States appears to be far greater than what we are experiencing over there at Abu Ghraib Prison. I ask unanimous consent that this be made a part of the record.

[The information referred to follows:]

Copyright 2004 Associated Press
All Rights Reserved

The Associated Press State & Local Wire

These materials may not be republished without the express
written consent of The Associated Press

May 12, 2004, Wednesday, BC cycle

SECTION: State and Regional

LENGTH: 1232 words

HEADLINE: Rights groups say prisoner abuse similar in Iraq, U.S.

BYLINE: By KATHARINE WEBSTER, Associated Press Writer

DATELINE: CONCORD, N.H.

BODY:

A man shackled to a post for hours in the blazing sun. Prisoners controlled with stun guns and shotguns. Guards sexually assaulting prisoners.

These are not photographs and accounts from the Abu Ghraib prison in Iraq, but documented cases from American prisons and jails.

U.S. Secretary of Defense Donald Rumsfeld recently called the abuses at Abu Ghraib "fundamentally un-American." Indeed, many Americans have reacted with horror to photos showing naked Iraqi prisoners shackled to cell bars and wearing black hoods, or piled in a heap with smiling American guards looking on.

But human rights groups say similar abuses occur with alarming frequency in American jails and prisons. There is little public outcry in part because there are no photos, said Elizabeth Alexander, director of the Prison Project for the American Civil Liberties Union.

"Beating prisoners, sexually abusing prisoners - all of these things go on in American prisons," Alexander said. "The public doesn't see it."

Jamie Fellner, director of U.S. programs at Human Rights Watch, said there are no national or state statistics on guard abuse of prisoners. But "what we

see in terms of court cases and monitoring reports is the tip of the iceberg," because there is no system of outside investigations, she said.

"Individual prisoners may exaggerate, officials may be minimizing ... but where we see a pattern of inmate complaints, we know there's a problem," she said.

The federal Bureau of Justice Statistics says 10 percent of state prisoners and 3 percent of federal prisoners report being injured in fights. Academic studies of state prison systems have found 14 percent to 22 percent of male inmates report being raped by other inmates, Fellner said.

And in prisons where rape and violence are rampant, officers and managers are tolerating or even facilitating the abuse, she said.

Often it takes a death or riot to bring prisoner abuse to public attention, Fellner said.

At Virginia's Red Onion and Wallens Ridge prisons, corrections officers routinely used stun guns and shotguns loaded with rubber pellets to control prisoners, according to Human Rights Watch. One prisoner from Connecticut died in 2000 after being repeatedly zapped with a stun gun at Wallens Ridge; Virginia paid \$350,000 to settle a lawsuit brought by his family and Connecticut paid \$1.1 million.

In Massachusetts, one corrections officer punched pedophile priest John Geoghan and another defecated in his cell, a state commission found. Geoghan was transferred to another prison, where an inmate known to hate pedophiles killed him last year.

In Alabama, corrections officers handcuffed prisoners to a metal post in the scorching sun for hours until a judge outlawed the practice in 1998. In 2002, the U.S. Supreme Court agreed it was "cruel and unusual punishment."

In Texas, evidence in a class-action lawsuit "revealed a prison underworld in which rapes, beatings and servitude are the currency of power" and "prison officials at all levels play a game of willing disbelief," U.S. District Judge William Wayne Justice wrote.

In New Hampshire, federal officials removed 250 immigration and U.S. Marshal detainees from the Hillsborough County jail in 2000 over allegations that guards physically abused male inmates and sexually abused female inmates. Inmates have filed more than 150 lawsuits against the jail since 1993.

At the Ohio Reformatory for Women, male corrections officers routinely sexually assaulted women or trade privileges for sex, and women who complained were put in isolation as punishment, according to a December report by Stop Prisoner Rape based on testimony by three former prison employees.

And it's common in American prisons and jails for female corrections officers to watch male inmates shower and use the toilet, and vice versa, Fellner and Alexander said.

The root causes of prisoner abuse are the same in Iraq and the United States - bad training and supervision, overcrowding, lack of outside scrutiny, and the near-total control guards exercise over prisoners, said James Gondles, executive director of the American Correctional Association.

"You have almost absolute power over other individuals, and that is a system that could easily breed abuse," he said.

But Gondles said there are important differences between the situation in Iraq and at home.

"I've never seen any written reports that allege that (American) inmates are stripped naked and either shackled to bars or made to pile on one another or stand in front of women and pose for pictures," he said.

He also says abuse is not routine in American prisons and jails.

"It's an exception, and when it's found out it's quickly investigated and actions are taken to either demote or punish the individual if they were found to be guilty ... or they're charged criminally," he said.

Gondles said professionalism among American prison officials has increased greatly in recent decades, especially among wardens and command staff. Fellner agreed, but said at the same time, the mushrooming incarceration rate means guards are often poorly trained and inexperienced.

Another difference, said Hans Scherrer, spokesman for Prison Legal News of Seattle, which reports on prison conditions and prisoners' rights: The American guards in the Abu Ghraib photos appear proud, like victors in a war.

"There are a lot of photos from World War II where German soldiers took pictures of atrocities they committed - they were proud of it," he said. Here, guards are afraid that if a photo "gets in the wrong hands, they're going to be sued."

In Iraq, a soldier immediately alerted superiors when he discovered photos of fellow 372nd Military Police Company personnel abusing prisoners at Abu Ghraib.

In this country, successful criminal prosecutions of abusive guards are extremely difficult. "because you don't have picture evidence and it's rare that a guard will actually testify against another one," Scherrer said.

Alexander and Scherrer wish the American public would get as outraged by inmate abuse in the United States as at Abu Ghraib.

But they believe too many Americans share the attitude expressed by U.S. Sen. Jim Inhofe, R-Okla., who said Tuesday he was "more outraged by the outrage" from some quarters than by the way Iraqi prisoners were treated.

"They're murderers, they're terrorists, they're insurgents. Many of them probably have American blood on their hands, and here we're so concerned about the treatment of those individuals," Inhofe said.

Scherrer said he has heard similar sentiments about abuse in U.S. prisons and jails.

"People in prison are perceived as criminals who deserve their treatment," he said. "Part of (their) punishment is to be treated as something less than a human being, with no thought to what happens when that person gets out."

On the Net:

"Medical Problems of Inmates, 1997," U.S. Dept. of Justice Statistics:
<http://www.ojp.usdoj.gov/bjs/pub/pdf/mp197.pdf>

American Correctional Association: <http://www.aca.org/>

ACLU Prisons Project: <http://www.aclu.org/Prisons/PrisonsMain.cfm>

Human Rights Watch prison reports: <http://www.hrw.org/prisons/reports.html>

"The Sexual Abuse of Female Inmates in Ohio" by Stop Prisoner Rape:
<http://www.spr.org/pdf/sexabuseohio.pdf>

Prison Legal News: <http://www.prisonlegalnews.org/>

Dr. BROWN. It is notable, Senator, that at least two of the non-commissioned officers involved in the photograph abuses were reservists who in civilian life were prison guards.

Senator INHOFE. Now, that is interesting because when you talk about the photographs, they say what is the difference. Why is there no public outcry? These human rights groups say it is because there are no photographs. If there were, there would be because the incidence is far greater than it was in Abu Ghraib.

I thank you folks for the fine work that you have done.

Thank you, Mr. Chairman. Pardon the interruption.

Dr. SCHLESINGER. Let me add on that we do understand that prison life is hard in the United States, and that is not when you are under mortar fire as Abu Ghraib was. As those mortar shells came in from time to time, it did not improve the disposition of the MPs in the facility. So it is harder out there in the field in a combat zone.

The reason that we had them at Abu Ghraib was that the rise of the insurgency meant that it was hard to transport elsewhere. Abu Ghraib in itself had been, in a sense, loaded on to what had been intended to be a civilian prison. Next door in Tier 2, you had Iraqi criminals under Iraqi guards. The atmosphere was, as a result, even worse in some sense than an American prison.

Chairman WARNER. We must proceed now. Thank you very much.

Senator Kennedy.

Senator KENNEDY. Thank you very much, and I join those in commending Secretary Schlesinger and Secretary Brown for their extraordinary service to our country. I thank them.

I would just mention quickly I would like to put in the record that New York Times article. "General says less coercion of captives yields better data. American interrogators who have worked in Iraq have obtained as much as 50 percent more highly valued intelligence since the series of coercive practices like hooding, striping, and sleep deprivation were barred, said Major General Miller, who has basically had it both ways." So if we are really interested in trying to get the information, I think we have pretty good examples of how that best can be done.

[The information referred to follows:]

Copyright © 2004 The New York Times Company
The New York Times

September 7, 2004 Tuesday
Late Edition - Final

SECTION: Section A; Column 1; Foreign Desk; THE REACH OF WAR: INTELLIGENCE; Pg. 12

LENGTH: 1160 words

HEADLINE: General Says Less Coercion of Captives Yields Better Data

BYLINE: By DEXTER FILKINS

DATELINE: BAGHDAD, Iraq, Sept. 6

BODY:

American interrogators working in Iraq have obtained as much as 50 percent more high-value intelligence since a series of coercive practices like hooding, stripping and sleep deprivation were banned, a senior American official said Monday.

Maj. Gen. Geoffrey Miller, the American commander in charge of detentions and interrogations, said that the number of "high-value" intelligence reports drawn from interrogations of Iraqi prisoners had increased by more than half on a monthly basis since January. That was when American officials first disclosed that they were investigating abuses of Iraqi prisoners at the hands of American military police and intelligence officers at Abu Ghraib.

Such intelligence is used to hunt down guerrillas, prevent attacks and break up insurgent networks. The military defines a "high value" intelligence report as one that describes what is regarded as a significant piece of information about the insurgency.

But the successes listed by General Miller were tempered by the release this week of figures showing that the guerrilla insurgency in Iraq appears to be reaching a new level of intensity, raising questions about the value of the intelligence. An American military official said Monday that American soldiers and their allies were attacked an average of

87 times each day in August, the highest such figure since American and British forces deposed Saddam Hussein and his government 17 months ago.

General Miller, the former commandant of the American detention center in Guantanamo Bay, Cuba, attributed the greater success at intelligence gathering to a system that encourages the establishment of a "rapport" between interrogator and detainee and bestows "respect and dignity" on the person being interrogated.

In May, a number of physically and psychologically coercive practices used by interrogators to break down suspected Iraqi insurgents were prohibited, following reports of widespread abuse at Abu Ghraib. Among those techniques banned by American commanders were sleep deprivation, hooding, stripping and the use of dogs to frighten detainees.

"In my opinion, a rapport-based interrogation that recognizes respect and dignity, and having very well-trained interrogators, is the basis by which you develop intelligence rapidly and increase the validity of that intelligence," General Miller said in a briefing for reporters. "It is very similar to what you would see civilian law enforcement authorities use."

The system described by General Miller appears to mark a change in the chaotic and often coercive environment that prevailed at Abu Ghraib prison in late 2003 and early 2004, when a number of American soldiers assaulted and humiliated Iraqi prisoners. In testimony and photographs that have since been made public, Iraqis were shown to have been severely and regularly abused at the prison, often for the stated purpose of persuading them to provide more information on the insurgency.

Those abuses, still being investigated by the military and other public agencies, have so far resulted in criminal charges against seven American soldiers. One of those charged has pleaded guilty.

General Miller toured Iraq's prisons last summer but did not take command of them until April, after leaving his post as commandant of the American prison for Qaeda and Afghan war prisoners at Guantanamo. In his time at Guantanamo, General Miller was credited with setting up a system that extracted a large amount of intelligence from detainees, and often very quickly. He was brought to Abu Ghraib to set up a similar system.

General Miller said he had imposed a series of far-reaching changes on the workings of Abu Ghraib prison and the other detention camps in Iraq, in order to ensure that prisoners were treated more humanely and that intelligence flowed quickly.

General Miller suggested that he had needed some time to get the system working, and to bolster the morale of the police and intelligence officers following the scandal.

"In May, June and July, we made slow progress, because we were developing our teams again, getting our procedures, and allowing them to get their confidence built back up," General Miller said.

Of the coercive tactics formerly in use in Iraq, only one -- holding a prisoner in isolation for more than 30 days -- is still permitted, and then only with the permission of a senior officer. To date, even that tactic has not been used since General Miller's arrival, said a senior American military officer who spoke on the condition of anonymity.

General Miller first toured Abu Ghraib last summer, when the insurgency began to pick up momentum. The unexpected intensity of the rebellion has been cited in several investigations as having contributed to the atmosphere that led to the abuses at the prison.

At the time, the number of attacks on American soldiers and other members of the coalition averaged close to 50 a day -- a figure considerable lower than the number of attacks last month.

Since arriving, General Miller has imposed a number of other changes intended to make the detention and interrogation system more efficient and to make it more acceptable to Iraqis. The prison population, which peaked last year at close to 10,000, has dropped to about 5,500 now, according to the senior military official.

The official also said the changes had addressed one of the Iraqis' principal

complaints: that it takes far too long to process those arrested and to release the innocent. According to the military official, what used to take between 120 and 140 days is now down to an average of 60 days.

The rapid release of so many Iraqi prisoners does not appear to have contributed to the intensification of the insurgency, the official said. Of the thousands of Iraqi detainees who have been released, only about 25 have been recaptured on suspicion of taking part in attacks on American forces, the military officer said.

That statistic appears to buttress the finding by human rights groups and the International Committee for the Red Cross that an overwhelming majority of the Iraqis detained in American prisons in Iraq had nothing to do with the insurgency.

The American official also said that among the 5,500 Iraqis now being held, only two are women -- both of them, he said, "high-value detainees" who were involved in "Iraq's weapons of mass destruction program." The American prisons hold some 65 to 70 juveniles, 40 of whom are scheduled to be released by Sept. 15, he added.

Between 130 and 140 non-Iraqi foreigners suspected of supporting the insurgency are being held in Iraq, the official said. The American official said that a "small number" of suspected foreign fighters had been released, "the vast majority" of whom had been handed over to the governments of the countries from which they came.

Some 750 Iraqis have been handed over to the Iraqi criminal justice system, where they will be tried for attacking American troops.

URL: <http://www.nytimes.com>

GRAPHIC: Photo: Handcuffed Iraqi detainees were watched by an American soldier in Baghdad last month. Fewer Iraqis are being held by U.S. troops. (Pool photo by David P. Gilkey)

LOAD-DATE: September 7, 2004

Senator KENNEDY. Now, before the war, the Pentagon simply ignored some of the post-war planning carried out by the State Department. I was here in the Armed Services Committee. We had Doug Feith who gave a single presentation. I thought it was extremely weak myself. Others thought it was very adequate. But the civilian leadership at the DOD was convinced the war would be fast, cheap, and easy, and they ridiculed those like General Shinseki, the then Chief of Staff of the Army; and Larry Lindsey, former Chairman of the White House National Economic Council, who said that a successful war would require hundreds of thousands of soldiers and hundreds of billions of dollars. They put their own ideology above practical military planning. We continue to see the catastrophic results.

The abuses at Abu Ghraib are just one part of a much larger failure and our soldiers have been paying the price since day one. They were not adequately trained for their mission and they did not have adequate equipment for it either, talking about the Abu Ghraib and these reports that we have been considering today. After the President prematurely declared the mission accomplished, the civilian leadership at DOD took him seriously and left our Armed Forces in Iraq, I think, underprepared, understaffed, underled for the mission they were really just beginning.

Our soldiers have responded to the challenges with immense courage and dedication. That does not excuse the incompetence of civilian leadership.

According to the Jones-Fay report, the leadership plans envisioned that General Sanchez would be provided the stability and support to the Coalition Provisional Authority (CPA) in a relatively non-hostile environment. That has been referred to here. The defense leadership did not anticipate or prepare for the robust hostilities that actually occurred. That is on page 2 of the Jones-Fay report. General Sanchez was missing two-thirds of the personnel he needed for his command in Iraq. That is on page 8 of the report.

Of the 1,400 personnel required, the B Corps staff transitioned to 495, roughly a third of the manning requirements. "The military police, military intelligence unit at Abu Ghraib under-resourced." That is on page 2. "Failure to distinguish between Iraq and the other theaters of operation led to confusion about what interrogation techniques were authorized in Iraq," page 5. "The intelligence structure was undermanned, under-equipped, and inappropriately organized for counterinsurgency," page 11.

We also know from General Taguba's report that few, if any, of the MP soldiers assigned to Abu Ghraib had been trained on how to run a prison or on the requirements of the Geneva Conventions.

Again and again, the glaring mismanagement of the Iraq war has been, I believe, a colossal failure of leadership. No one has been held accountable.

Compare this to the way the Pentagon has handled other leadership failures. A few weeks ago, the Navy fired the captain of the U.S.S. *John F. Kennedy* for running over a small boat in the Persian Gulf. The Navy said they had lost confidence in his ability to operate the carrier safely. He was the 11th commanding officer of the Navy to be fired this year. The Navy fired 14 commanding officers in 2003.

In February 2004, the commanding officer of the U.S.S. *Samuel Roberts* was fired for a loss of confidence after he spent a night off the ship during a port visit in Ecuador.

On October 3, 2003, a commanding officer of an EA-6B Prowler aircraft squadron lost his job after one of his jets skidded off a runway. The Navy cited a loss of confidence when they made the decision to fire him.

In December 2003 and January 2004, respectively, the commanding officers of the submarine Jimmy Carter and U.S.S. *Gary* were fired both for loss of confidence.

For the military officers in the Navy, the message is clear. If you fail, you are fired.

Is it not time the DOD ran a tighter ship at all levels of command, including the civilian leadership? Dr. Schlesinger, Dr. Brown, do you not believe that civilian leadership in the Pentagon should be held to the same standard of accountability that military officers in the Navy, for example, have been held to? Who is accountable? Who should be fired? Should it be General Sanchez, General Abizaid, General Myers, Deputy Secretary of Defense Wolfowitz, Secretary of Defense Rumsfeld, the President? The buck has to stop somewhere. Every naval officer knows where it stops. Why does the civilian leadership that has made the grievous errors left the soldiers and sailors holding the bag? Why are they not held accountable too?

Dr. SCHLESINGER. It is more complicated.

Senator KENNEDY. More complicated than what?

Dr. SCHLESINGER. It is a more complicated issue with regard to these command levels. In the case of the Navy, if a naval commander runs his ship aground or fails to cover his ship, the Navy has this long tradition that you have pointed out. But that does not mean that at higher levels, in which one is facing a determined opposition, that the same "fire immediately" is appropriate. If we had had those rules in World War II, we would have fired General Ei-

senhower right after Kasserine Pass. General MacArthur would never have landed at Inchon simply because he would have been fired.

Senator KENNEDY. We are not in World War II.

Senator SESSIONS [presiding]. Let him answer, Senator Kennedy.

Senator KENNEDY. My time is up.

Dr. SCHLESINGER. The point is that it is different standards.

Senator KENNEDY. Different standards. We are not in World War II. These are the reports that are coming out. This is not just what I am saying. This is what is in the reports. This is what is in those reports. These are the findings, and there has not been, as far as I know, a single member of the civilian authority that has been held accountable.

Dr. BROWN. Let me answer from a perspective that may be rather different from Jim's on the question of how to deal at the highest level, the presidential level.

At each level, the question is loss of confidence, and in the Navy, the loss of confidence goes with grounding your ship. At a higher level, the loss of confidence has to be determined on a basis that is somewhat broader, the full performance. I think that applies at the highest military levels and it applies at the level of the Secretary of Defense and his staff. The Secretary of Defense has to decide whether he has lost confidence in his under secretaries or his assistant secretaries on the basis of their performance, and the electorate has to decide on the basis of its confidence at election time.

Senator SESSIONS. Your time has expired, Senator Kennedy.

Senator KENNEDY. Yes, if you will just yield.

Senator SESSIONS. You are well beyond your time, Senator Kennedy.

Senator KENNEDY. Are you going to cut—I will be the first one that has been—

Senator SESSIONS. I be glad to go to the second round, but Senator Graham has been here and the time is well long since expired.

Senator Graham.

Senator GRAHAM. Thank you.

We will probably get a better answer to this after November. I am convinced of that. But generally speaking, a disproportionate response will haunt us for years, and it goes both ways. I totally believe that one of the most damaging things that can happen to our military and all of us believe to the core of our being that the many do great, the few will not be excused. But the many have a sense of fairness and if at the end of the day, gentlemen, the only people that are court-martialed are sergeants, you are going to have a very dispirited group of men and women in uniform because they understand some of the things that Senator Kennedy said.

Now, to my colleague from Massachusetts, if we take this event, which is a blight on our military's honor and an aberration of who we are, and we try to make it a November issue, we are creating an equal disservice.

My belief, in terms of Secretary Rumsfeld, and you confirm this if you think it is accurate, is that when he tried to implement the policy that people and the Taliban and Al Qaeda would not be subject to the Geneva Conventions, but would be treated humanely, he

received legal recommendations that came out of the White House, the DOJ, and the Pentagon. There were 35 interrogation techniques initially presented. Is that correct?

Dr. BROWN. That is correct.

Dr. SCHLESINGER. Yes.

Senator GRAHAM. Now, I am going to call on this committee to release the Judge Advocate memos that are classified, I think, inappropriately. Those memos suggest that those interrogation techniques that were being proposed by civilian authorities were way out of bounds, that they violated the UCMJ, they violated international law, and they would get our people in trouble.

I think an appropriate response is for those people who tried to cut the corners too close in the Justice Department and the White House set in motion some legal reasoning that literally got our people in trouble. Now, I am going to ask the chairman to release that information.

But when it came time for Secretary Rumsfeld to deal with this dilemma, is this an accurate statement, when he heard that there was push-back from military lawyers, he stopped the process and convened a collaborative group, is that correct?

Dr. SCHLESINGER. Yes.

Dr. BROWN. Correct.

Senator GRAHAM. That group looked at this anew and the policy was changed. Is that correct?

Dr. BROWN. Correct.

Dr. SCHLESINGER. Yes. I think he behaved very responsibly in that regard.

Senator GRAHAM. So do I, but I think our policies about troops, enough people were not well-conceived. That is not for you to decide. That is for us to decide.

But during the course of your investigation, did you ever sense that a commander was afraid to ask for more troops because it may be a career adverse event?

Dr. SCHLESINGER. One can speculate on that. We did not have any evidence or sense during the course of that.

Dr. BROWN. We did not see it, but that does not mean that it was not there.

Senator GRAHAM. One final question about the dogs. Let me tell you about the photos. The first explanation about the photos was a suggestion by some members of this committee that the people involved in the photos were the worst terrorists in the world and they deserve what they got. Then Colonel Warren comes along and says some of the people in the photos were just normal criminals, which made me to suggest this was aberrant behavior unconnected with interrogation.

Now we have gone to where there is only one person in the photo subject to interrogation. That is a 180 degree turn.

I keep getting back to the use of the dogs. You have a colonel, who is a well-respected person in his field, telling investigators that the dogs came about as a result of a suggestion or a recommendation from General Miller, the use of the dogs in interrogation. We know that the use of the dogs got written down somewhere. How did that happen? What happened with the dogs?

Senator SESSIONS. Is this Colonel Pappas you are talking about?

Senator GRAHAM. Yes. Somebody is lying at the highest level. There is no way to reconcile this. You cannot say it is confusion on his part because it came on a document out of his control. Do you have any idea how that scenario with these dogs got to be part of the interrogation techniques of the United States Army?

Dr. SCHLESINGER. Just two comments. General Miller indicated that dogs could be used but they must be muzzled, as I understand it.

Senator GRAHAM. Were they used as part of an interrogation technique?

Dr. SCHLESINGER. I am not saying that because I have no remembrance of that.

Senator GRAHAM. It is my understanding—and I do not want to confuse you, that he suggested the dogs be used for perimeter security. Colonel Pappas is saying no, the reason we used the dogs is because it came from Guantanamo Bay. But apart from General Miller and Colonel Pappas, you have, on one of these forms about interrogation, military dogs. Do we know how that happened? To me that is very important.

Dr. SCHLESINGER. The dog trainers believed that they were there to provide perimeter security. When they got there, they were seduced, persuaded into using the dogs in interrogation.

Senator GRAHAM. Who did the seducing and persuading?

Dr. SCHLESINGER. That was either the MI people or the MP people. Now, that does not preclude having the suggestion come from higher up. We did not have that kind of evidence.

Senator GRAHAM. How did it get into a written interrogation policy?

Dr. SCHLESINGER. I beg your pardon?

Senator GRAHAM. How did it get on the sheet from General Sanchez's office?

Dr. SCHLESINGER. I indicated earlier that General Sanchez, as described by his legal advisor, felt that he had this inherent authority. Now, I do not know how it got on there. That is something that you may well explore.

Senator GRAHAM. Thank you. You both have served your Nation well. Thank you for what you have done.

Senator SESSIONS. I would note that in General Sanchez's defense, I do not think the report mentions that. As I recall, he did add some techniques that probably are not justifiable under the strict rulings of the law, but he did say they could not be used without his personal approval. Is that correct?

Dr. SCHLESINGER. That is correct.

Dr. BROWN. Yes.

Senator SESSIONS. Nobody ever requested to use any of those enhanced techniques, and he never approved any of those enhanced techniques.

Senator GRAHAM. But, Senator, they were used and I do not know how that started.

Senator SESSIONS. Well, you know how, Senator Graham.

Dr. SCHLESINGER. He did approve isolation.

Senator SESSIONS. I am trying to help a little bit on General Sanchez. He did not say, "Go use these techniques." He said these

are possible techniques. If you decide that you want to use them, I want to personally approve it.

Senator Reed.

Chairman WARNER [presiding]. Senator Reed is next, yes.

Senator REED. Thank you very much.

Mr. Secretary, thank you for your report. I think one thing you did, among many admirable things, is to make it quite clear that Operation Iraqi Freedom was governed by the Geneva Conventions. Afghanistan was not. Guantanamo was not. But I think you also raised the complexity. I think the best way, from my view, to approach this is not the procedures but the types of people that are categorized: enemy prisoners of war under the third Geneva Conventions, protected persons under the fourth Geneva Conventions, and a third category perhaps of unlawful combatants.

Now, Dr. Brown, in your testimony you suggested that this definition of unlawful combatant, as applied to Iraq, was restricted to foreign terrorists.

Dr. BROWN. That is my understanding.

Senator REED. Is that your understanding? Foreign terrorists?

Dr. BROWN. Yes. Resisters do not qualify under that category.

Senator REED. Now, in October 2003, Secretary Rumsfeld, at the request of Mr. Tenet, ordered military chain of command to deny at least the registration rights under the Geneva Conventions to an individual who I believe is an Iraqi citizen, part of Al Ansalam. Do you think that is consistent with the application of the Geneva Conventions to Iraq?

Dr. SCHLESINGER. The answer to that is no. It is not consistent.

Dr. BROWN. If that happened, that is not consistent.

Dr. SCHLESINGER. I think that that is something that should be examined under the heading of intelligence, if I may just throw in that.

Senator REED. Thank you, Mr. Secretary.

Now, this decision was staffed down the line from General Myers, General Sanchez, and General Abizaid. It was a decision of the Secretary of Defense. It was an order given by him. Do you think that in any way colored their judgments about what they could do; i.e., we can declare anybody an enemy combatant if we think they are dangerous enough? Or it simply reflected the fact that this issue of the rules of the game were confused not just in Iraq and with General Sanchez, but all the way up to the Secretary of Defense's Office?

Dr. SCHLESINGER. There are, I think, special rules that apply to the CIA, and in our discussion we recommended that there needs to be a better definition of the relationships between the CIA and the DOD.

Senator REED. Dr. Brown?

Dr. BROWN. I am not sure how this event affected the thinking of those military commanders, but we did not see any sign that they acted in a way that corresponded, that is, that they created ghost prisoners.

Senator REED. Let me ask a follow-up question, if I may. My understanding of the opinion of the White House counsel, Mr. Gonzales, is that the only individual that could designate people as enemy combatants or to relieve the restrictions of the Geneva Con-

ventions was the President of the United States. Is that correct? Was that delegated to the Secretary of Defense?

Dr. BROWN. I do not know.

Dr. SCHLESINGER. I do not know the answer to that.

Senator REED. Is that a question that is worth pursuing?

Dr. SCHLESINGER. Yes, indeed. I think that you have to pursue that, as I say, in the intelligence area.

Senator REED. Thank you.

Let me change the subject. You are critical of General Fast for her performance of her duties. We heard today from General Kern and from his colleagues that they have a great deal of admiration for her performance in many aspects, and I share that having met her briefly.

But what is revealing to me is that General Fast's responsibilities were divided, not formally but effectively, between General Sanchez and Mr. Bremer. Did you ask Ambassador Bremer or anyone in the CPA what instructions or decisions that they gave to her or anyone else with respect to Abu Ghraib intelligence operations? Dr. Schlesinger, Dr. Brown?

Dr. SCHLESINGER. No.

Dr. BROWN. We did not speak with Jerry Bremer.

Senator REED. So you have a critical intelligence officer who is at the heart of so much of this who is responding not only to General Sanchez but to the direct representative of the Secretary of Defense, Ambassador Bremer, and he has not been questioned, that is correct?

Dr. BROWN. That is correct.

Senator REED. Who did the CIA station chief work for effectively in Iraq?

Dr. SCHLESINGER. Let me modify that statement about Ambassador Bremer. He was nominally under the Secretary of Defense, but in fact he responded directly to the White House.

Senator REED. He responded directly to the White House.

Again, my time has expired. Effectively who did the CIA station chief work for in Iraq?

Dr. SCHLESINGER. The CIA station chief should be working for Ambassador Bremer.

Senator REED. Should be working for Ambassador Bremer? General Fast is working for Ambassador Bremer. Much of the difficulties we have seen, the reports of abuse, stem from a failure to coordinate military rules and regulations with the CIA. All roads seem to lead to CPA and through CPA directly to the White House in this regard. Is that the subject of an appropriate inquiry?

Dr. SCHLESINGER. Well, "all these lead" strikes me as a little strong, but it certainly points in that direction, yes.

Senator REED. Dr. Brown?

Dr. BROWN. Yes.

Senator REED. Thank you very much.

Chairman WARNER. The question is an important one, and I want to make sure the implications from the question and your very brief response are quite clear. Are you suggesting that there was anything specifically relating to this prisoner issue that was dealt with by Ambassador Bremer that was inconsistent with law

or regulation or could have contributed to the problems that we are dealing with?

Dr. SCHLESINGER. No. We are dealing with a somewhat different issue.

Chairman WARNER. I know but we are going astray here.

Dr. SCHLESINGER. Ambassador Bremer was the one who set up Abu Ghraib as a civilian prison. Later on that was adapted to bring in military prisoners, and the MPs were in charge of Tier 1. But that was an adjustment that was made because of the insurgency that precluded movement to other facilities that would have been preferable. Those roads were dangerous to go over, but yes, he was deeply involved in Abu Ghraib.

Chairman WARNER. But you laid the foundation, Secretary Schlesinger, that Ambassador Bremer was responsive to the White House in large measure, as opposed to the Secretary of Defense.

Dr. SCHLESINGER. As a practical matter, yes.

Chairman WARNER. I want to make certain that you were not implying that the White House had something to do with this prison situation.

Dr. SCHLESINGER. Oh, absolutely not.

Chairman WARNER. I want to make that clear. I listened very carefully.

Dr. SCHLESINGER. Oh, yes, absolutely. I was responding to Senator Reed. He raised the question about the relationship between the military and the civilian authorities, and they were not good in Iraq. They were not as good, for example, as the relationship between General Abrams and Lawrence Bunker in the later on in Vietnam after the early days. That, as the Senator pointed out, was a defect in our operations.

Chairman WARNER. Vietnam. I remember that. But nothing to do with this prison situation.

Dr. SCHLESINGER. No, sir.

Chairman WARNER. I want to get that clear.

Senator REED. Mr. Chairman, if I may, since I posed the question. I do not want to unfairly take advantage of the response. My question, simply stated, is that Ambassador Bremer had significant responsibilities for both coordinating the CIA operations and also coordinating many of the activities of the intelligence chain of command in the military under General Fast. He has not been asked by any panel any significant questions about what guidance he gave to either the CIA or to General Fast. I think this is all correct. I assumed, until I was corrected by Secretary Schlesinger, that he was directly under the direction of the Secretary of Defense.

So my question was simply that. I just think that is a huge, huge gap in any kind of accountability of what went on with respect to Abu Ghraib and many other things in Iraq.

Thank you, Mr. Chairman.

Chairman WARNER. For the record, Senator Levin and I tried to get Ambassador Bremer here before we went on the summer recess period, but we were unsuccessful in achieving that.

Now we will go next to our colleague. Have we completed on this side? We will then now proceed with Senator Ben Nelson.

Senator SESSIONS. I think I am next.

Chairman WARNER. Sorry. I had to depart the room for a period of time. I thought you had gotten your time.

Senator SESSIONS. No, I did not.

Gentlemen, you both served as Secretary of Defense. You, Secretary Schlesinger, as Secretary of Energy under President Carter and Secretary of Defense later under President Reagan.

But I thought that it was significant that the report all agreed that no approved procedures called for or allowed the kind of abuse that in fact occurred and no evidence of a policy of abuse promulgated by senior officials or military authorities.

I also noticed that the first soldier that was court-martialed in an Associated Press report, I am quoting from them, "He said the mistreatment was not authorized by higher-ups in the chain of command. 'Our command would have slammed us,' he said. 'They believe in doing the right thing. If they knew what was going on, there would have been hell to pay.'"

So I think one of the things that is causing us confusion and some of this I think may be almost deliberate confusion here. But you have the situation in which we had the photographs of these abuses, which were absolutely against any policy, any regulation. Nothing could have justified those abuses, I think we would all agree.

Then there is a second question and that is, were any of the written guidelines and policies that came down from General Sanchez, the Secretary of Defense, CENTCOM, or wherever, improper, and did any of them lead to abuses?

I guess you would agree that none of the policies, and your report stated that plainly I think, would have justified the photographed abuses by that night shift group?

Dr. BROWN. That is correct.

Dr. SCHLESINGER. Turn that around, Senator.

Dr. BROWN. They prohibited them.

Dr. SCHLESINGER. No one who had suggested these kinds of abuses if hypothetically somebody had suggested these kinds of abuses, the last thing that would have been ordered would be that there be photographic evidence of it.

Senator SESSIONS. I think no doubt of that.

So you get to the point of what about these 44 abuses. You take 10, I do not know how many, 10 or so individuals involved in the photograph situation. Then you have some more abuses. Most of those, I guess you would say, were the result also of a lack of discipline and a failure to follow any of the policies that might have been in existence. Is that fair to say?

Dr. SCHLESINGER. Yes.

Dr. BROWN. They were all against policy, yes.

Senator SESSIONS. There might be some. I do not know. Were there any of the abuses in this gray area that we keep hearing about that somehow one of these orders that said you might use a dog muzzled or whatever, that may have led to an abuse? Are there any that come down on the question of gray areas and interpretation?

Dr. BROWN. I think the problem, Senator Sessions, is that when the rules keep changing, some people may say, well, the rules keep changing, maybe some other things are allowed.

Dr. SCHLESINGER. Also, there was a migration of personnel from Afghanistan into Iraq and the rules in Afghanistan were, to say the least, more lenient on these issues than they should have been in Iraq.

Senator SESSIONS. I think clearly the President was correct in declaring al Qaeda an unlawful combatant and not legally subjected to the Geneva Conventions, although he ordered they be treated humanely. I think many of the people in Iraq do not qualify clearly for the same protections, but the President gave it to them and they decided to give it to them and treat them as if they did qualify. But un-uniformed terrorist attackers on American soldiers and civilians in Iraq are not soldiers that qualify as lawful combatants under the rules of warfare.

But regardless, my only point was to suggest that, yes, it is great that we look at the rules, the definitions, make sure that our soldiers know that with more clarity. But really, most of the problems that occurred were people that would have been in violation of any definitions in any of the rules. Is that correct?

Dr. SCHLESINGER. Yes, unquestionably.

Dr. BROWN. Yes.

Senator SESSIONS. I do understand. As a former Federal prosecutor, I had to investigate police abuse cases, and it is a thankless task. A lot of times it occurred; you say one-third of the abuse cases occurred on the scene when somebody is chasing an outlaw, in a shoot-out with an outlaw, in a high-speed chase, sometimes those police officers are pumped up and they go too far, and it is wrong. It should not happen. Most officers do not go too far, but some do, and that is when a lot of the problems occur. I think that is distinct from the confusion over what is a legitimate interrogation technique and what is not.

Dr. SCHLESINGER. Right.

Senator SESSIONS. Thank you, Mr. Chairman. That is all.

Chairman WARNER. Thank you very much.

Now, Senator Ben Nelson.

Senator BEN NELSON. Thank you, Mr. Chairman. Thank you, gentlemen, for your service and certainly this has not been the easiest assignment that you have had over the years but clearly one of the most important ones.

General Kern, this morning, was talking about General Sanchez, and he said, without taking anything away from General Sanchez's overall performance, that there were some shortcomings in that performance. But he also referred to him as a hero. So I do not want to take anything away either.

But if there is a responsibility, rather than just culpability, in the case of General Sanchez and we evaluate the overall performance, is there a different standard for General Sanchez with those shortcomings than running a ship aground? Do you just not get another star? Can you shed some light from your own experience about what happens if there are shortcomings in someone's performance, whether they are as egregious as this may appear to be or they may be egregious in another manner?

Dr. BROWN. Every case is different and every standard is different depending upon the institution. As I said, when a captain

runs his ship aground or collides with another ship, even if he was not personally on the bridge, they lose confidence in him.

Senator BEN NELSON. What is the standard for the Army, or do we know?

Dr. BROWN. You do not run your ship aground in the Army.

Senator BEN NELSON. That is right.

Dr. BROWN. It is more complicated. It is not so easy to formulate a simple rule in the Army. General Sanchez is responsible. He did a great job in some ways. He under-performed in other ways, and that has had a consequence on his promotion. Indeed, in the Navy, the captain is not sent to jail when he runs his ship aground. He is pretty unlikely to be promoted.

Senator BEN NELSON. I wonder, is that the standard here for the Army? It is probably unfair to General Sanchez to be dragging it out like this and speculating, but the question has been raised about the shortcomings. So I am curious about what kind of penalty, what kind of standard is being considered here.

Dr. SCHLESINGER. That is for the Army to decide.

Senator BEN NELSON. But from your experience of having been in that civilian control in the past, what would you think might be a consequence?

Dr. BROWN. Failure of promotion is a pretty severe consequence.

Senator BEN NELSON. Stuck at three stars.

Dr. SCHLESINGER. That is right. In General Sanchez's case, may I repeat that there are extenuating circumstances in that he had only one-third of his staff, one-third of the authorized staff. He was trying to fight a war. He was adjusting from a role as division commander to corps commander. He did sense there was something wrong at Abu Ghraib. He went there four times to visit the facility. So there were things going on, but he was a busy man.

Senator BEN NELSON. Do we know whether he asked for additional headquarters staff?

Dr. SCHLESINGER. Oh, absolutely.

Senator BEN NELSON. Now, if there is a standard for the military, now let us go to the civilian. We go from the chain of command now to the DOD, from chain of command to DOD. What kind of standards would we expect people there to be held to? You have said you would not fire the Secretary of Defense for this situation, but is there anybody below that level, as you have looked at this and studied it, that you think Donald Trump ought to say "you are fired"?

Dr. SCHLESINGER. We were prepared to consider that. Now, in testimony before this committee, General Sanchez and General Abizaid stated that the Secretary of Defense states the policy. We in the Army execute that policy. We do not go back for additional guidance. What they were saying is we do not seek oversight from the OSD once the policy is established.

We looked into a number of people in the OSD, and there were some who might, at the outset, have expected to find greater evidence there of responsibility. There was none in our judgment at lower levels in the OSD.

If you look up at the military chain of command, the area in which we found a problem was in terms of organizing the appro-

ropriate forces for Iraq and seeing to it that there were enough MPs there.

The information on the photos came up through to CENTCOM. There was a lieutenant colonel there who looked at the photos and kind of shrugged and did not send them any further up. Now, it seems to me that that is a real failure to recognize the policy significance and the political significance for the United States of America of those photos being unleashed on the world. So that was a failure of an individual in CENTCOM.

Further up the chain of command, one can argue that there should have been a better sense that there was a problem with regard to MPs, interrogators, interpreters and the like, and there was none. That we characterize as a sin of omission.

Dr. BROWN. I would add one point. I think at the level of the staff of the Secretary of Defense, I would agree with Jim Schlesinger that there is a distinction between policy and execution, and that the military chain of command was responsible for the execution. The staff of the Secretary of Defense, I think, could have been more aware and attentive to what was going on and exercised some sort of oversight that they failed to do in connection with some of these.

Senator BEN NELSON. How serious is that and is that punishable?

Dr. BROWN. It is up to the Secretary of Defense to decide, and I think he cannot decide it on the basis solely of this particular issue, prisoner abuse. He has to decide it for each individual on the totality of that individual's performance. Again, it is not like running your ship aground.

Senator BEN NELSON. They may not get promoted but they do not have to worry about getting another star.

Dr. BROWN. Well, lots of things can happen.

Senator BEN NELSON. I understand.

Dr. SCHLESINGER. In that case, the promotion or the decisions about whether to keep a man or a woman depends upon their direct responsibilities more than what is in this case an indirect responsibility. As Harold indicated, they might well have been more curious about what was going on, but they too had other responsibilities.

Senator BEN NELSON. Thank you, gentlemen. Thank you, Mr. Chairman.

Chairman WARNER. Thank you, Senator.

Senator Talent.

Senator TALENT. Thank you, Mr. Chairman. I really want to thank the witnesses for, I think, a really extraordinarily helpful investigation and testimony.

Let me give a summary and tell me if it is basically correct just to make sure my understanding of your report is accurate.

The pictures we all saw that started all this ironically enough are not related to the interrogation abuse that we are now really discussing. That really was a kind of sicko scrapbook that those people put together on their own, if I understand your report correctly. There was no policy or sanctioning by senior officers or civilians of abuse of any kind. I would have been very surprised to find otherwise. The abuse resulted from an unexpectedly unstable over-

all environment, under-resourcing, and an unexpectedly large and varied mix of prisoners in Iraq. Then added to that, was confusion over the specific rules of interrogation because, in some places, the Geneva Conventions did not apply, in some places it did, and it was not made clear enough to the forces on the ground what exactly they were supposed to do. Is that a fair summary? As I take away from this and I am asked back home, what does all this amount to, that is a fair summary?

Dr. SCHLESINGER. Yes, sir.

Dr. BROWN. Yes. I think you should add that the results were serious. It happened in a fairly widespread way. I think we at least got over the idea there were only a few bad apples pretty early, but it happened as you describe.

Senator TALENT. Yes. I would have been surprised if the kind of stuff I saw in those pictures was at all widespread because that was just sick.

Dr. BROWN. We were not able to find evidence of that sort of pathology anywhere else.

Senator TALENT. Yes. People going too far in an effort to get information in an insecure environment where their friends are being shot at and they are desperate to find out what is going on, while inexcusable in one sense, in another sense is at least understandable, in a way, those pictures never were to me. So this is certainly a common sense conclusion.

The only other thing I would say, Mr. Chairman, I think we have gone over the issues, is something the two Secretaries said in response to Mr. Nelson that I think is worth repeating. In hindsight, we are focusing on this aspect of the war and appropriately so, and it is certainly important. When you are actually operating the thing, as you all have done in different contexts, it is very important to maintain a sense of proportion. Had they gone too far in the other direction, focused too much on all of this, and taken resources away from other things, we could now be holding a hearing about why you did not resource adequately enough in other areas and you spent too much time on this. So clearly more should have been done. I just think we ought to keep in mind that we are acting with the benefit of a hindsight that they did not have.

Thank you, Mr. Chairman.

Senator LEVIN. You are the chairman.

Senator TALENT [presiding]. I guess I am the chairman. All right. [Laughter.]

We have been through one round. We will recognize the Senator from Michigan.

Senator LEVIN. Thank you, Senator Talent.

On the ghost detainees issue, at this morning's hearing I asked our witnesses if they had looked into the relationship, if any, of Secretary Rumsfeld's approval of Director Tenet's request to keep a CIA detainee at a military detention facility in Iraq without informing the ICRC of his presence, to the presence of ghost detainees at Abu Ghraib. We were informed that their investigation had not looked into that issue.

Did your panel or did any other DOD investigation you know of look into that issue as to the approval of a maintenance of a CIA

detainee without notice, anonymously, and in violation of the Geneva Conventions?

Dr. SCHLESINGER. In Camp Cropper, General Dayton heard about assertions that there might be abuse on the part of CIA people and declared, as a matter of commander, that from then on CIA people would not be permitted to question detainees in the absence of DOD personnel being present.

Senator LEVIN. First of all, what is your reaction to the approval by the Secretary of Defense of the CIA keeping a detainee in violation of the Geneva Conventions rules?

Dr. SCHLESINGER. As I have said several times, the committee should look at that from an intelligence standpoint. I think that there are authorities that apply to the Secretary of Defense and the notion that he was sort of a free agent here, I think should be looked at with some care.

Dr. BROWN. In relation to another matter that is under active consideration, the committee ought to think about what would happen if you had a Director of National Intelligence who was in charge of such detention operations because they were national intelligence and could use quite different rules from Army FM 34-52.

Senator LEVIN. I think it is very good advice.

Now, is the panel aware of how CIA interrogation practices and guidelines differ from the military's?

Dr. SCHLESINGER. By reputation, the practices were somewhat more severe, but the panel did not have clear information in that regard. I simply report the reputation.

Dr. BROWN. Yes. We know of it but we do not know it.

Senator LEVIN. The ICRC has reviewed your report apparently and has posted a response on its web site taking exception to a number of your panel's findings. I would like to get your comment on one of their responses.

In your report you state, "If we were to follow the ICRC's interpretations, interrogation operations would not be allowed." The ICRC response to that statement was on their web site: "The ICRC has never stated, suggested, or intimated that interrogation of any detainee is prohibited regardless of the detainee's status or lack of status under the Geneva Conventions."

So what is then the basis of your assertion that the ICRC's view is that interrogation operations are not allowed?

Dr. BROWN. It depends on what you mean by interrogation. If finding out someone's name and serial number—

Senator LEVIN. They were talking beyond that.

Dr. BROWN. Are they?

Senator LEVIN. Oh, yes, absolutely.

Dr. BROWN. Not in what you have said.

Senator LEVIN. No, but in your report you said name, rank, and serial number. They take exception to your report.

Dr. BROWN. My understanding is that the ICRC serves a very useful purpose and its early warning signals were ignored here, and that was part of the problem. But it is my understanding that they support the protocol, which we do not, to the Geneva Conventions. The protocol identifies what we call terrorists as prisoners of

war. The ICRC is really pretty clear on how you can treat prisoners of war. You can ask them their name, rank, and serial number.

Senator LEVIN. You can ask them other questions, but they do not have to give anything more than name, rank, and serial number. Is that not accurate? That is not a quibble.

Dr. BROWN. No, I think that is true. But they have also characterized pushing them beyond that as torture.

Senator LEVIN. Asking questions?

Dr. BROWN. No. Doing more than asking questions.

Senator LEVIN. No, no. I am not talking about anything other than asking questions.

Dr. BROWN. No, no. But interrogation consists of more than asking questions.

Senator LEVIN. But has the ICRC ever said that you cannot ask questions beyond name, rank, and serial number?

Dr. BROWN. No.

Senator LEVIN. They have never said that. I think that is what they are objecting to.

Dr. BROWN. I see. There is a distinction between interrogation and asking questions.

Senator LEVIN. There is a distinction between interrogation and improper interrogation too.

Dr. BROWN. That is another distinction, but it is not the same distinction.

Senator LEVIN. From what they say, apparently as I understand it, they do not have any objection to asking proper questions. No one has to answer them. But as I understand it from what they say, they have not said you cannot interrogate somebody. What they have said is that no one has to give you more than name, rank, and serial number, and anything improper obviously is improper.

Dr. SCHLESINGER. No, Senator. The staff had a meeting with the ICRC and the ICRC made several points. The first of those points was, according to the notes of the meeting, the ICRC believes that the integration of interrogation and detention has become psychological torture.

Senator LEVIN. Automatically. So in other words, you think it is the ICRC position? I am not disagreeing with you.

Dr. SCHLESINGER. That is what was recorded in the notes.

Senator LEVIN. In that case, then the ICRC has an explanation as to whether they believe that interrogation, which does not involve any abusive stuff, just asking questions, is improper. That is something which we ought to ask the ICRC, and we will do that.

My last question.

Dr. SCHLESINGER. If the integration of interrogation and detention represents psychological torture, that is a continuation of a belief that we should not engage in interrogation.

Senator LEVIN. I would agree. If that is their position that you cannot ask anything, when someone is detained, other than name, rank, and serial number, and that to ask a question without any improper, abusive conduct, just asking, no isolation, no dogs, no anything, just asking the questions is improper, then there is a real difference here.

My last question is this. You indicate in your report that in November 2003, a senior member of the National Security staff visited Abu Ghraib, leading some personnel at the facility to conclude, perhaps incorrectly, that even the White House was interested in the intelligence gleaned from their interrogation reports. You also then indicate that, and this, I guess, is the Fay report that indicated that the pressure that was felt by members of the Intelligence Community, the intense pressure that they felt from higher headquarters, and here I am quoting the Fay report, "to include CENTCOM, the Pentagon, and the Defense Intelligence Agency for timelier, actionable intelligence," in their words, "adversely affected their decisionmaking," that intense pressure. Can you comment on that? Do you agree with that?

Dr. SCHLESINGER. I think that that is likely to be true, that there was an eagerness for intelligence, for actionable intelligence, and that eagerness constituted psychological pressure.

Senator LEVIN. Do you agree with that, Dr. Brown?

Dr. BROWN. Yes, but that is different from being instructed to do something. It is hard to apportion blame under such circumstances.

Senator LEVIN. Do you know the purpose of that visit of the NSC staff to Abu Ghraib in November 2003?

Dr. SCHLESINGER. The staff member was there to look at intelligence resources that might be required. That was the purpose of the visit or the stated purpose of that visit.

Senator LEVIN. Thank you. Thank you, Mr. Chairman.

Chairman WARNER. Thank you very much.

One short question, gentlemen, and then we will terminate a very good hearing.

Senator GRAHAM. Mr. Chairman, I am sorry.

Chairman WARNER. Yes.

Senator GRAHAM. Can I just have a few questions once you get through?

Chairman WARNER. We will do that. We note there is a vote on.

My question would be as follows. Drawing on your own experience, what measures would you take, were you to be Secretary of Defense today, to ensure the effective functioning of a rapid reporting system back to you of news which could have major international and other serious implications on the ongoing operations of a military operation and/or foreign policy such that you can communicate with the President about any problems within your respective commands? I know Secretary Rumsfeld has this under consideration. He has noted the imperative need for change in this regard in view of the instantaneous transmission of news worldwide now. What kind of procedures would you put in place, and how must those procedures be adapted to protect the UCMJ and the responsibilities thereunder?

Dr. SCHLESINGER. The Air Force has had such a procedure and we recommend that the DOD, the other Services, embrace the Air Force's procedure in this regard. I should, of course, caution that there is no way of assuring that that will ever happen.

Chairman WARNER. You are suggesting that is a model for each to look at.

Dr. SCHLESINGER. Yes, that is a model.

Dr. BROWN. It is and it involves the establishment of a very small group that pays attention to this kind of thing and sends the word up.

Chairman WARNER. We have a vote, and one of our gentlemen has to get on an airplane. But you go ahead as best you can.

Senator GRAHAM. Very quickly. I do appreciate your patience.

You said something before, that General Sanchez asked for more headquarters personnel, that he asked for more people. Is that correct?

Dr. SCHLESINGER. That is correct in the sense that he was entitled to 1,400 and he had something on the order of 400, and therefore the message was bring me up to my necessary complement.

Senator GRAHAM. Did he get the number he requested?

Dr. SCHLESINGER. No, he did not.

Senator GRAHAM. Who told him no?

Dr. SCHLESINGER. Oh, I am not sure that he was told no. It is just that there was a build-up from the low 33 percent level but it never got to the full complement. I think there was an effort to respond, a natural effort to respond, but he never got to the full complement.

Dr. BROWN. That request went to CENTCOM.

Senator GRAHAM. CENTCOM, okay.

Finally, the root cause I am trying to get to, and you have been so patient, about how we got on this slippery slope about interrogation techniques to me is very interesting, and I do not think it is within the Pentagon. Is my understanding correct that the Pentagon was receiving information from the DOJ and the White House counsel about a suggested game plan for interrogating al Qaeda and Taliban members that came from outside the Department? Is that correct?

Dr. BROWN. I do not know that that is the case. I think that they were aware of the very broad authority suggested in the OLC memorandum.

Dr. SCHLESINGER. I do not know that there was any direct recommendation to the Department, but it certainly is fair to say both that the Department would understandably pay some deference to an OLC memorandum and that some of the influence was there.

Senator GRAHAM. Do you believe, given all that you know about this, that part of the problem, we experienced later on, is that some legal forces were set in motion that clearly cut corners, that clearly violated the spirit of international law, not only the letter, clearly violated the spirit of the Geneva Conventions, clearly were going in the direction against humane treatment, that that was a phenomenon that existed early on?

Dr. SCHLESINGER. Certainly some of the statements that appeared in the second OLC memorandum are in that direction.

Senator GRAHAM. I am referring to the second, yes.

Dr. SCHLESINGER. I think that it is clear.

Senator GRAHAM. Secretary Brown?

Dr. BROWN. Yes.

Dr. SCHLESINGER. The eagerness with which that has been, if not disowned, pushed aside suggests that.

Dr. BROWN. The way I would put it is that there were clearly some lawyers who were saying, "here is what you might be able to get away with rather than saying here is what is right."

Senator GRAHAM. Thank you very much.

Dr. SCHLESINGER. But it is also clearly an exercise in constitutional expression of constitutional limits, a long tradition, I think, of the OLC do not impose limits on the President of the United States. I think that goes back many years.

Chairman WARNER. Gentlemen, the vote is about to come. We want to thank you very much for another chapter of public service, by no means the last. You have brought an important perspective to this otherwise very difficult issue. I commend the Secretary of Defense for convening this panel and I commend each of you for discharging your responsibility in a very pragmatic, forthright, and honest way.

Dr. SCHLESINGER. Thank you, Mr. Chairman.

Dr. BROWN. Thank you so much, Mr. Chairman.

Chairman WARNER. Thank you. The hearing is adjourned.

[The Final Report of the Independent Panel to Review DOD Detention Operations follows:]

**Final Report
of the
Independent Panel To Review
DoD Detention Operations**



August 2004

**Independent Panel to Review
DoD Detention Operations**

Chairman

The Honorable James R. Schlesinger

Panel Members

The Honorable Harold Brown

The Honorable Tillie K. Fowler

General Charles A. Homer (USAF-RET)

Executive Director

Dr. James A. Blackwell, Jr.



INDEPENDENT PANEL TO REVIEW DOD DETENTION OPERATIONS

CHAIRMAN
THE HONORABLE JAMES R. SCHLESINGER

PANEL MEMBERS
THE HONORABLE HAROLD BROWN
THE HONORABLE TILLIE K. FOWLER
GENERAL CHARLES A. HORNER (USAF-RET.)

EXECUTIVE DIRECTOR
DR. JAMES A. BLACKWELL, JR.

August 24, 2004

To U.S. Secretary of Defense Donald Rumsfeld

We, the appointed members of the Independent Panel to Review DoD Detention Operations, pursuant to our charter do hereby submit the results of our findings and offer our best recommendations.

Sincerely,

The Honorable James R. Schlesinger
Chairman

The Honorable Harold Brown
Panel Member

The Honorable Tillie K. Fowler
Panel Member

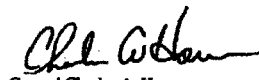
General Charles A. Horner
(USAF -Ret.)
Panel Member

**The Independent Panel to Review
Department of Defense
Detention Operations**

August 2004

Table of Contents

Executive Summary	5
Introduction – Charter and Methodology.....	21
The Changing Threat.....	27
The Policy Promulgation Process	33
Public Release of Abuse Photos	39
Command Responsibilities	43
Military Police and Detention Operations	53
Interrogation Operations	63
The Role of Military Police and Military Intelligence in Detention Operations	71
Laws of War/Geneva Conventions	79
The Role of the International Committee of the Red Cross	85
Recommendations	89
Appendices	93

Table of Appendices

Glossary.....	Appendix A
Secretary of Defense Memorandum appointing the Independent Panel.....	Appendix B
President of the United States Memorandum, February 7, 2002.....	Appendix C
Interrogation Policies.....	Appendix D
Evolution of Interrogation Techniques.....	Appendix E
Timeline, Major Detention Events.....	Appendix F
Psychological Stresses.....	Appendix G
Ethical Issues.....	Appendix H

Executive Summary

OVERVIEW

The events of October through December 2003 on the night shift of Tier 1 at Abu Ghraib prison were acts of brutality and purposeless sadism. We now know these abuses occurred at the hands of both military police and military intelligence personnel. The pictured abuses, unacceptable even in wartime, were not part of authorized interrogations nor were they even directed at intelligence targets. They represent deviant behavior and a failure of military leadership and discipline. However, we do know that some of the egregious abuses at Abu Ghraib which were not photographed did occur during interrogation sessions and that abuses during interrogation sessions occurred elsewhere.

In light of what happened at Abu Ghraib, a series of comprehensive investigations has been conducted by various components of the Department of Defense. Since the beginning of hostilities in Afghanistan and Iraq, U.S. military and security operations have apprehended about 50,000 individuals. From this number, about 300 allegations of abuse in Afghanistan, Iraq or Guantanamo have arisen. As of mid-August 2004, 155 investigations into the allegations have been completed, resulting in 66 substantiated cases. Approximately one-third of these cases occurred at the point of capture or tactical collection point, frequently under uncertain, dangerous and violent circumstances.

Abuses of varying severity occurred at differing locations under differing circumstances and context. They were widespread and, though inflicted on only a small percentage of those detained, they were serious both in number and in effect. No approved procedures called for or allowed the kinds of abuse that in fact occurred. There is no evidence of a policy of abuse promulgated by senior officials or military authorities. Still, the abuses were not just the failure of some individuals to follow known standards, and they are more than the failure of a few leaders to enforce proper discipline. There is both institutional and personal responsibility at higher levels.

INDEPENDENT PANEL TO REVIEW DOD DETENTION OPERATIONS

Secretary of Defense Donald Rumsfeld appointed the members of the Independent Panel to provide independent professional advice on detainee abuses, what caused them and what actions should be taken to preclude their repetition. The Panel reviewed various criminal investigations and a number of command and other major investigations. The Panel also conducted interviews of relevant persons, including the Secretary and Deputy Secretary of Defense, other senior Department of Defense officials, the military chain-of-command and their staffs and other officials directly and indirectly involved with Abu Ghraib and other detention operations. However, the Panel did not have full access to information involving the role of the Central Intelligence Agency in detention operations; this is an area the Panel believes needs further investigation and review. It should be noted that information provided to the Panel was that available as of mid-August 2004. If additional information becomes available, the Panel's judgments might be revised.

POLICY

With the events of September 11, 2001, the President, the Congress and the American people recognized we were at war with a different kind of enemy. The terrorists who flew airliners into the World Trade Center and the Pentagon were unlike enemy combatants the U.S. has fought in previous conflicts. Their objectives, in fact, are to kill large numbers of civilians and to strike at the heart of America's political cohesion and its economic and military might. In the days and weeks after the attack, the President and his closest advisers developed policies and strategies in response. On September 18, 2001, by a virtually unanimous vote, Congress passed an Authorization for Use of Military Force. Shortly thereafter, the U.S. initiated hostilities in Afghanistan and the first detainees were held at Mazar-e-Sharrif in November 2001.

On February 7, 2002, the President issued a memorandum stating that he determined the Geneva Conventions did not apply to the conflict with al Qaeda, and although they did apply in the conflict with Afghanistan, the Taliban were unlawful combatants and

therefore did not qualify for prisoner of war status (see Appendix C). Nonetheless, the Secretary of State, Secretary of Defense, and the Chairman of the Joint Chiefs of Staff were all in agreement that treatment of detainees should be consistent with the Geneva Conventions. The President ordered accordingly that detainees were to be treated “. . . humanely and, to the extent appropriate and consistent with military necessity, in a manner consistent with the principles of Geneva.” Earlier, the Department of State had argued the Geneva Conventions in their traditional application provided a sufficiently robust legal construct under which the Global War on Terror could effectively be waged. The Legal Advisor to the Chairman, Joint Chiefs of Staff, and many of the military service attorneys agreed with this position.

In the summer of 2002, the Counsel to the President queried the Department of Justice Office of Legal Counsel (OLC) for an opinion on the standards of conduct for interrogation operations conducted by U.S. personnel outside of the U.S. and the applicability of the Convention Against Torture. The OLC responded in an August 1, 2002 opinion in which it held that in order to constitute torture, an act must be specifically intended to inflict severe physical or mental pain and suffering that is difficult to endure.

Army Field Manual 34-52 (FM 34-52), with its list of 17 authorized interrogation methods, has long been the standard source for interrogation doctrine within the Department of Defense (see Appendix D). In October 2002, authorities at Guantanamo requested approval of stronger interrogation techniques to counter tenacious resistance by some detainees. The Secretary of Defense responded with a December 2, 2002 decision authorizing the use of 16 additional techniques at Guantanamo (see Appendix E). As a result of concerns raised by the Navy General Counsel on January 15, 2003, Secretary Rumsfeld rescinded the majority of the approved measures in the December 2, 2002 authorization. Moreover, he directed the remaining more aggressive techniques could be used only with his approval (see Appendix D).

INDEPENDENT PANEL TO REVIEW DOD DETENTION OPERATIONS

At the same time, he directed the Department of Defense (DoD) General Counsel to establish a working group to study interrogation techniques. The Working Group was headed by Air Force General Counsel Mary Walker and included wide membership from across the military legal and intelligence communities. The Working Group also relied heavily on the OLC. The Working Group reviewed 35 techniques and after a very extensive debate ultimately recommended 24 to the Secretary of Defense. The study led to the Secretary of Defense's promulgation on April 16, 2003 of a list of approved techniques strictly limited for use at Guantanamo. This policy remains in force at Guantanamo (see Appendix E).

In the initial development of these Secretary of Defense policies, the legal resources of the Services' Judge Advocates General and General Counsels were not utilized to their full potential. Had the Secretary of Defense had a wider range of legal opinions and a more robust debate regarding detainee policies and operations, his policy of April 16, 2003 might well have been developed and issued in early December 2002. This would have avoided the policy changes which characterized the Dec 02, 2002 to April 16, 2003 period.

It is clear that pressures for additional intelligence and the more aggressive methods sanctioned by the Secretary of Defense memorandum, resulted in stronger interrogation techniques that were believed to be needed and appropriate in the treatment of detainees defined as "unlawful combatants." At Guantanamo, the interrogators used those additional techniques with only two detainees, gaining important and time-urgent information in the process.

In Afghanistan, from the war's inception through the end of 2002, all forces used FM 34-52 as a baseline for interrogation techniques. Nonetheless, more aggressive interrogation of detainees appears to have been on-going. On January 24, 2003, in response to a data call from the Joint Staff to facilitate the Working Group efforts, the Commander Joint Task Force-180 forwarded a list of techniques being used in

Afghanistan, including some not explicitly set out in FM 34-52. These techniques were included in a Special Operation Forces (SOF) Standard Operating Procedures document published in February 2003. The 519th Military Intelligence Battalion, a company of which was later sent to Iraq, assisted in interrogations in support of SOF and was fully aware of their interrogation techniques.

Interrogators and lists of techniques circulated from Guantanamo and Afghanistan to Iraq. During July and August 2003, the 519th Military Intelligence Company was sent to the Abu Ghraib detention facility to conduct interrogation operations. Absent any explicit policy or guidance, other than FM 34-52, the officer in charge prepared draft interrogation guidelines that were a near copy of the Standard Operating Procedure created by SOF. It is important to note that techniques effective under carefully controlled conditions at Guantanamo became far more problematic when they migrated and were not adequately safeguarded.

Following a CJTF-7 request, Joint Staff tasked SOUTHCOM to send an assistance team to provide advice on facilities and operations, specifically related to screening, interrogations, HUMINT collection, and inter-agency integration in the short and long term. In August 2003, MG Geoffrey Miller arrived to conduct an assessment of DoD counter-terrorism interrogation and detention operations in Iraq. He was to discuss current theater ability to exploit internees rapidly for actionable intelligence. He brought the Secretary of Defense's April 16, 2003 policy guidelines for Guantanamo with him and gave this policy to CJTF-7 as a possible model for the command-wide policy that he recommended be established. MG Miller noted that it applied to unlawful combatants at Guantanamo and was not directly applicable to Iraq where the Geneva Conventions applied. In part as a result of MG Miller's call for strong, command-wide interrogation policies and in part as a result of a request for guidance coming up from the 519th at Abu Ghraib, on September 14, 2003 LTG Sanchez signed a memorandum authorizing a dozen interrogation techniques beyond Field Manual 34-52—five beyond those approved for Guantanamo (see Appendix D).

INDEPENDENT PANEL TO REVIEW DOD DETENTION OPERATIONS

MG Miller had indicated his model was approved only for Guantanamo. However, CJTF-7, using reasoning from the President's Memorandum of February 7, 2002 which addressed "unlawful combatants," believed additional, tougher measures were warranted because there were "unlawful combatants" mixed in with Enemy Prisoners of War and civilian and criminal detainees. The CJTF-7 Commander, on the advice of his Staff Judge Advocate, believed he had the inherent authority of the Commander in a Theater of War to promulgate such a policy and make determinations as to the categorization of detainees under the Geneva Conventions. CENTCOM viewed the CJTF-7 policy as unacceptably aggressive and on October 12, 2003 Commander CJTF-7 rescinded his September directive and disseminated methods only slightly stronger than those in Field Manual 34-52 (see Appendix D). The policy memos promulgated at the CJTF-7 level allowed for interpretation in several areas and did not adequately set forth the limits of interrogation techniques. The existence of confusing and inconsistent interrogation technique policies contributed to the belief that additional interrogation techniques were condoned.

DETENTION AND INTERROGATION OPERATIONS

From his experience in Guantanamo, MG Miller called for the military police and military intelligence soldiers to work cooperatively, with the military police "setting the conditions" for interrogations. This MP role included passive collection on detainees as well as supporting incentives recommended by the military interrogators. These collaborative procedures worked effectively in Guantanamo, particularly in light of the high ratio of approximately 1 to 1 of military police to mostly compliant detainees. However, in Iraq and particularly in Abu Ghraib the ratio of military police to repeatedly unruly detainees was significantly smaller, at one point 1 to about 75 at Abu Ghraib, making it difficult even to keep track of prisoners. Moreover, because Abu Ghraib was located in a combat zone, the military police were engaged in force protection of the complex as well as escorting convoys of supplies to and from the prison. Compounding

these problems was the inadequacy of leadership, oversight and support needed in the face of such difficulties.

At various times, the U.S. conducted detention operations at approximately 17 sites in Iraq and 25 sites in Afghanistan, in addition to the strategic operation at Guantanamo. A cumulative total of 50,000 detainees have been in the custody of U.S. forces since November 2001, with a peak population of 11,000 in the month of March 2004.

In Iraq, there was not only a failure to plan for a major insurgency, but also to quickly and adequately adapt to the insurgency that followed after major combat operations. The October 2002 CENTCOM War Plan presupposed that relatively benign stability and security operations would precede a handover to Iraq's authorities. The contingencies contemplated in that plan included sabotage of oil production facilities and large numbers of refugees generated by communal strife.

Major combat operations were accomplished more swiftly than anticipated. Then began a period of occupation and an active and growing insurgency. Although the removal of Saddam Hussein was initially welcomed by the bulk of the population, the occupation became increasingly resented. Detention facilities soon held Iraqi and foreign terrorists as well as a mix of Enemy Prisoners of War, other security detainees, criminals and undoubtedly some accused as a result of factional rivalries. Of the 17 detention facilities in Iraq, the largest, Abu Ghraib, housed up to 7,000 detainees in October 2003, with a guard force of only about 90 personnel from the 800th Military Police Brigade. Abu Ghraib was seriously overcrowded, under-resourced, and under continual attack. Five U.S. soldiers died as a result of mortar attacks on Abu Ghraib. In July 2003, Abu Ghraib was mortared 25 times; on August 16, 2003, five detainees were killed and 67 wounded in a mortar attack. A mortar attack on April 20, 2004 killed 22 detainees.

Problems at Abu Ghraib are traceable in part to the nature and recent history of the military police and military intelligence units at Abu Ghraib. The 800th Military Police

INDEPENDENT PANEL TO REVIEW DOD DETENTION OPERATIONS

Brigade had one year of notice to plan for detention operations in Iraq. Original projections called for approximately 12 detention facilities in non-hostile, rear areas with a projection of 30,000 to 100,000 Enemy Prisoners of War. Though the 800th had planned a detention operations exercise for the summer of 2002, it was cancelled because of the disruption in soldier and unit availability resulting from the mobilization of Military Police Reserves following 9/11. Although its readiness was certified by U.S. Army Forces Command, actual deployment of the 800th Brigade to Iraq was chaotic. The "Time Phased Force Deployment List," which was the planned flow of forces to the theater of operations, was scrapped in favor of piecemeal unit deployment orders based on actual unit readiness and personnel strength. Equipment and troops regularly arrived out of planned sequence and rarely together. Improvisation was the order of the day. While some units overcame these difficulties, the 800th was among the lowest in priority and did not have the capability to overcome the shortfalls it confronted.

The 205th MI Brigade, deployed to support Combined Joint Task Force-7 (CJTF-7), normally provides the intelligence capability for a Corps Headquarters. However, it was insufficient to provide the kind of support needed by CJTF-7, especially with regard to interrogators and interpreters. Some additional units were mobilized to fill in the gaps, but while these MI units were more prepared than their military police counterparts, there were insufficient numbers of units available. Moreover, unit cohesion was lacking because elements of as many as six different units were assigned to the interrogation mission at Abu Ghraib. These problems were heightened by friction between military intelligence and military police personnel, including the brigade commanders themselves.

ABUSES

As of the date of this report, there were about 300 incidents of alleged detainee abuse across the Joint Operations Areas. Of the 155 completed investigations, 66 have resulted in a determination that detainees under the control of U.S. forces were abused. Dozens of

non-judicial punishments have already been awarded. Others are in various stages of the military justice process.

Of the 66 already substantiated cases of abuse, eight occurred at Guantanamo, three in Afghanistan and 55 in Iraq. Only about one-third were related to interrogation, and two-thirds to other causes. There were five cases of detainee deaths as a result of abuse by U.S. personnel during interrogations. Many more died from natural causes and enemy mortar attacks. There are 23 cases of detainee deaths still under investigation; three in Afghanistan and 20 in Iraq. Twenty-eight of the abuse cases are alleged to include Special Operations Forces (SOF) and, of the 15 SOF cases that have been closed, ten were determined to be unsubstantiated and five resulted in disciplinary action. The Jacoby review of SOF detention operations found a range of abuses and causes similar in scope and magnitude to those found among conventional forces.

The aberrant behavior on the night shift in Cell Block 1 at Abu Ghraib would have been avoided with proper training, leadership and oversight. Though acts of abuse occurred at a number of locations, those in Cell Block 1 have a unique nature fostered by the predilections of the noncommissioned officers in charge. Had these noncommissioned officers behaved more like those on the day shift, these acts, which one participant described as "just for the fun of it," would not have taken place.

Concerning the abuses at Abu Ghraib, the impact was magnified by the fact the shocking photographs were aired throughout the world in April 2004. Although CENTCOM had publicly addressed the abuses in a press release in January 2004, the photographs remained within the official criminal investigative process. Consequently, the highest levels of command and leadership in the Department of Defense were not adequately informed nor prepared to respond to the Congress and the American public when copies were released by the press.

INDEPENDENT PANEL TO REVIEW DOD DETENTION OPERATIONS

POLICY AND COMMAND RESPONSIBILITIES

Interrogation policies with respect to Iraq, where the majority of the abuses occurred, were inadequate or deficient in some respects at three levels: Department of Defense, CENTCOM/CJTF-7, and Abu Ghraib Prison. Policies to guide the demands for actionable intelligence lagged behind battlefield needs. As already noted, the changes in DoD interrogation policies between December 2, 2002 and April 16, 2003 were an element contributing to uncertainties in the field as to which techniques were authorized. Although specifically limited by the Secretary of Defense to Guantanamo, and requiring his personal approval (given in only two cases), the augmented techniques for Guantanamo migrated to Afghanistan and Iraq where they were neither limited nor safeguarded.

At the operational level, in the absence of specific guidance from CENTCOM, interrogators in Iraq relied on Field Manual 34-52 and on unauthorized techniques that had migrated from Afghanistan. On September 14, 2003 CJTF-7 signed the theater's first policy on interrogation, which contained elements of the approved Guantanamo policy and elements of the SOF policy (see Appendix D). Policies approved for use on al Qaeda and Taliban detainees, who were not afforded the protection of the Geneva Conventions, now applied to detainees who did fall under the Geneva Convention protections.

CENTCOM disapproved the September 14, 2003 policy, resulting in another policy signed on October 12, 2003 which essentially mirrored the outdated 1987 version of the FM 34-52 (see Appendix D). The 1987 version, however, authorized interrogators to control all aspects of the interrogation, "to include lighting and heating, as well as food, clothing, and shelter given to detainees." This was specifically left out of the current 1992 version. This clearly led to confusion on what practices were acceptable. We cannot be sure how much the number and severity of abuses would have been curtailed

had there been early and consistent guidance from higher levels. Nonetheless, such guidance was needed and likely would have had a limiting effect.

At the tactical level we concur with the Jones/Fay investigation's conclusion that military intelligence personnel share responsibility for the abuses at Abu Ghraib with the military police soldiers cited in the Taguba investigation. The Jones/Fay Investigation found 44 alleged instances of abuse, some which were also considered by the Taguba report. A number of these cases involved MI personnel directing the actions of MP personnel. Yet it should be noted that of the 66 closed cases of detainee abuse in Guantanamo, Afghanistan and Iraq cited by the Naval Inspector General, only one-third were interrogation related.

The Panel concurs with the findings of the Taguba and Jones investigations that serious leadership problems in the 800th MP Brigade and 205th MI Brigade, to include the 320th MP Battalion Commander and the Director of the Joint Debriefing and Interrogation Center (JDIC), allowed the abuses at Abu Ghraib. The Panel endorses the disciplinary actions taken as a result of the Taguba Investigation. The Panel anticipates that the Chain of Command will take additional disciplinary action as a result of the referrals of the Jones/Fay investigation.

We believe LTG Sanchez should have taken stronger action in November when he realized the extent of the leadership problems at Abu Ghraib. His attempt to mentor BG Karpinski, though well-intended, was insufficient in a combat zone in the midst of a serious and growing insurgency. Although LTG Sanchez had more urgent tasks than dealing personally with command and resource deficiencies at Abu Ghraib, MG Wojdakowski and the staff should have seen that urgent demands were placed to higher headquarters for additional assets. We concur with the Jones findings that LTG Sanchez and MG Wojdakowski failed to ensure proper staff oversight of detention and interrogation operations.

INDEPENDENT PANEL TO REVIEW DOD DETENTION OPERATIONS

We note, however, in terms of its responsibilities, CJTF-7 was never fully resourced to meet the size and complexity of its mission. The Joint Staff, CJTF-7 and CENTCOM took too long to finalize the Joint Manning Document (JMD). It was not finally approved until December 2003, six months into the insurgency. At one point, CJTF-7 had only 495 of the 1,400 personnel authorized. The command was burdened with additional complexities associated with its mission to support the Coalition Provisional Authority.

Once it became clear in the summer of 2003 that there was a major insurgency growing in Iraq, with the potential for capturing a large number of enemy combatants, senior leaders should have moved to meet the need for additional military police forces. Certainly by October and November when the fighting reached a new peak, commanders and staff from CJTF-7 all the way to CENTCOM to the Joint Chiefs of Staff should have known about and reacted to the serious limitations of the battalion of the 800th Military Police Brigade at Abu Ghraib. CENTCOM and the JCS should have at least considered adding forces to the detention/interrogation operation mission. It is the judgment of this panel that in the future, considering the sensitivity of this kind of mission, the OSD should assure itself that serious limitations in detention/interrogation missions do not occur.

Several options were available to Commander CENTCOM and above, including reallocation of U.S. Army assets already in the theater, Operational Control (OPCON) of other Service Military Police units in theater, and mobilization and deployment of additional forces from the continental United States. There is no evidence that any of the responsible senior officers considered any of these options. What could and should have been done more promptly is evidenced by the fact that the detention/interrogation operation in Iraq is now directed by a Major General reporting directly to the Commander, Multi-National Forces Iraq (MNF-I). Increased units of Military Police, fully manned and more appropriately equipped, are performing the mission once assigned to a single under-strength, poorly trained, inadequately equipped and weakly-led brigade.

In addition to the already cited leadership problems in the 800th MP Brigade, there were a series of tangled command relationships. These ranged from an unclear military intelligence chain of command, to the Tactical Control (TACON) relationship of the 800th with CJTF-7 which the Brigade Commander apparently did not adequately understand, and the confusing and unusual assignment of MI and MP responsibilities at Abu Ghraib. The failure to react appropriately to the October 2003 ICRC report, following its two visits to Abu Ghraib, is indicative of the weakness of the leadership at Abu Ghraib. These unsatisfactory relationships were present neither at Guantanamo nor in Afghanistan.

RECOMMENDATIONS

Department of Defense reform efforts are underway and the Panel commends these efforts. They are discussed in more detail in the body of this report. The Office of the Secretary of Defense, the Joint Chiefs of Staff and the Military Services are conducting comprehensive reviews on how military operations have changed since the end of the Cold War. The Military Services now recognize the problems and are studying force compositions, training, doctrine, responsibilities and active duty/reserve and guard/contractor mixes which must be adjusted to ensure we are better prepared to succeed in the war on terrorism. As an example, the Army is currently planning and developing 27 additional MP companies.

The specific recommendations of the Independent Panel are contained in the Recommendations section, beginning on page 87.

CONCLUSION

The vast majority of detainees in Guantanamo, Afghanistan and Iraq were treated appropriately, and the great bulk of detention operations were conducted in compliance with U.S. policy and directives. They yielded significant amounts of actionable intelligence for dealing with the insurgency in Iraq and strategic intelligence of value in the Global War on Terror. For example, much of the information in the recently released 9/11 Commission's report, on the planning and execution of the attacks on the World Trade Center and Pentagon, came from interrogation of detainees at Guantanamo and elsewhere.

Justice Sandra Day O'Connor, writing for the majority of the Supreme Court of the United States in *Hamdi v. Rumsfeld* on June 28, 2004, pointed out that "The purpose of detention is to prevent captured individuals from returning to the field of battle and taking up arms once again." But detention operations also serve the key purpose of intelligence gathering. These are not competing interests but appropriate objectives which the United States may lawfully pursue.

We should emphasize that tens of thousands of men and women in uniform strive every day under austere and dangerous conditions to secure our freedom and the freedom of others. By historical standards, they rate as some of the best trained, disciplined and professional service men and women in our nation's history.

While any abuse is too much, we see signs that the Department of Defense is now on the path to dealing with the personal and professional failures and remedying the underlying causes of these abuses. We expect any potential future incidents of abuse will similarly be discovered and reported out of the same sense of personal honor and duty that characterized many of those who went out of their way to do so in most of these cases. The damage these incidents have done to U.S. policy, to the image of the U.S. among

EXECUTIVE SUMMARY

populations whose support we need in the Global War on Terror and to the morale of our armed forces, must not be repeated.

INTRODUCTION—CHARTER AND METHODOLOGY

The Secretary of Defense chartered the Independent Panel on May 12, 2004, to review Department of Defense (DoD) Detention Operations (see Appendix A). In his memorandum, the Secretary tasked the Independent Panel to review Department of Defense investigations on detention operations whether completed or ongoing, as well as other materials and information the Panel deemed relevant to its review. The Secretary asked for the Panel's independent advice in highlighting the issues considered most important for his attention. He asked for the Panel's views on the causes and contributing factors to problems in detainee operations and what corrective measures would be required.

Completed investigations reviewed by the Panel include the following:

- Joint Staff External Review of Intelligence Operations at Guantanamo Bay, Cuba, September 28, 2002 (Custer Report)
- Joint Task Force Guantanamo assistance visit to Iraq to assess intelligence operations, September 5, 2003 (Miller Report)
- Army Provost Marshal General assessment of detention and corrections operations in Iraq, November 6, 2003 (Ryder Report)
- Administrative investigation under Army Regulation 15-6 (AR 15-6) regarding Abu Ghraib, June 8, 2004 (Taguba Report)
- Army Inspector General assessment of doctrine and training for detention operations, July 23, 2004 (Mikolashek Report)

INDEPENDENT PANEL TO REVIEW DOD DETENTION OPERATIONS

- The Fay investigation of activities of military personnel at Abu Ghraib and related LTG Jones investigation under the direction of GEN Kern, August 16, 2004
- Naval Inspector General's review of detention procedures at Guantanamo Bay, Cuba and the Naval Consolidated Brig, Charleston, South Carolina (A briefing was presented to the Secretary of Defense on May 8, 2004.)
- Naval Inspector General's review of DoD worldwide interrogation operations, due for release on September 9, 2004
- Special Inspection of Detainee Operations and Facilities in the Combined Forces Command-Afghanistan AOR (CFC-A), June 26, 2004 (Jacoby Report).
- Administrative Investigation of Alleged Detainee Abuse by the Combined Joint Special Operations Task Force -- Arabian Peninsula (Formica Report) Due for release in August, 2004. Assessment not yet completed and not reviewed by the Independent Panel
- Army Reserve Command Inspector General Assessment of Military Intelligence and Military Police Training (due for release in December 2004)

Panel interviews of selected individuals either in person or via video-teleconference:

June 14, 2004:

- MG Keith Dayton, Director, Iraq Survey Group (ISG), Baghdad, Iraq
- MG Geoffrey Miller, Director, Detainee Operations, CJTF-7, Baghdad, Iraq
- Hon Donald Rumsfeld, Secretary of Defense
- Hon Steve Cambone, Under Secretary of Defense for Intelligence
- MG Walter Wojdakowski, Deputy Commanding General, V Corps, USAREUR and 7th Army

- MG Donald Ryder, Provost Marshal, U.S. Army/Commanding General, U.S. Army Criminal Investigation Command, Washington, D.C.
- COL Thomas Pappas, Commander, 205th Military Intelligence Brigade, V Corps, USAREUR and 7th Army

June 24, 2004:

- LTG David McKiernan, Commanding General, Third U.S. Army, U.S. Army Forces Central Command, Coalition Forces Land Component Command
- MG Barbara Fast, CJTF-7 C-2, Director for Intelligence, Baghdad, Iraq
- MG Geoffrey Miller, Director, Detainee Operations, CJTF-7, Baghdad, Iraq
- LTG Ricardo Sanchez, Commanding General, CJTF-7, Commanding General, V Corps, USAREUR and 7th Army in Iraq
- Mr. Daniel Dell'Orto, Principal Deputy General Counsel, DoD
- LTG Keith Alexander, G-2, U.S. Army, Washington, D.C.
- LTG William Boykin, Deputy Undersecretary of Defense for Intelligence, Intelligence and Warfighting Support, Office of the Under Secretary of Defense for Intelligence
- Hon Douglas Feith, Under Secretary of Defense for Policy

July 8, 2004:

- COL Marc Warren, Senior Legal Advisor to LTG Sanchez, Iraq
- BG Janis Karpinski, Commander (TPU), 800th Military Police Brigade, Uniondale, NY
- Hon Paul Wolfowitz, Deputy Secretary of Defense
- Hon William Haynes, General Counsel DoD
- Mr. John Rizzo, CIA Senior Deputy General Counsel
- GEN John Abizaid, Commander, U.S. Central Command
- MG George Fay, Deputy to the Army G2, Washington, D.C.
- VADM Albert Church III, Naval Inspector General

July 22, 2004:

- Hon Donald Rumsfeld, Secretary of Defense

The Panel did not conduct a case-by-case review of individual abuse cases. This task has been accomplished by those professionals conducting criminal and commander-directed investigations. Many of these investigations are still on-going. The Panel did review the various completed and on-going reports covering the causes for the abuse. Each of these inquiries or inspections defined abuse, categorized the abuses, and analyzed the abuses in conformity with the appointing authorities' guidance, but the methodologies do not parallel each other in all respects. The Panel concludes, based on our review of other reports to date and our own efforts that causes for abuse have been adequately examined.

The Panel met on July 22nd and again on August 16th to discuss progress of the report. Panel members also reviewed sections and versions of the report through July and mid-August.

An effective, timely response to our requests for other documents and support was invariably forthcoming, due largely to the efforts of the DoD Detainee Task Force. We conducted reviews of multiple classified and unclassified documents generated by DoD and other sources.

Our staff has met and communicated with representatives of the International Committee of the Red Cross and with the Human Rights Executive Directors' Coordinating Group.

It should be noted that information provided to the Panel was that available as of mid-August 2004. If additional information becomes available, the Panel's judgments might be revised.

THE CHANGING THREAT

The date September 11, 2001, marked an historic juncture in America's collective sense of security. On that day our presumption of invulnerability was irretrievably shattered. Over the last decade, the military has been called upon to establish and maintain the peace in Bosnia and Kosovo, eject the Taliban from Afghanistan, defeat the Iraqi Army, and fight ongoing insurgencies in Iraq and Afghanistan. Elsewhere it has been called upon to confront geographically dispersed terrorists who would threaten America's right to political sovereignty and our right to live free of fear.

In waging the Global War on Terror, the military confronts a far wider range of threats. In Iraq and Afghanistan, U.S. forces are fighting diverse enemies with varying ideologies, goals and capabilities. American soldiers and their coalition partners have defeated the armored divisions of the Republican Guard, but are still under attack by forces using automatic rifles, rocket-propelled grenades, roadside bombs and surface-to-air missiles. We are not simply fighting the remnants of dying regimes or opponents of the local governments and coalition forces assisting those governments, but multiple enemies including indigenous and international terrorists. This complex operational environment requires soldiers capable of conducting traditional stability operations associated with peacekeeping tasks one moment and fighting force-on-force engagements normally associated with war-fighting the next moment.

Warfare under the conditions described inevitably generates detainees—enemy combatants, opportunists, trouble-makers, saboteurs, common criminals, former regime officials and some innocents as well. These people must be carefully but humanely processed to sort out those who remain dangerous or possess militarily-valuable intelligence. Such processing presents extraordinarily formidable logistical, administrative, security and legal problems completely apart from the technical obstacles posed by communicating with prisoners in another language and extracting actionable intelligence from them in timely fashion. These activities, called detention operations,

INDEPENDENT PANEL TO REVIEW DOD DETENTION OPERATIONS

are a vital part of an expeditionary army's responsibility, but they depend upon training, skills, and attributes not normally associated with soldiers in combat units.

Military interrogators and military police, assisted by front-line tactical units, found themselves engaged in detention operations with detention procedures still steeped in the methods of World War II and the Cold War, when those we expected to capture on the battlefield were generally a homogenous group of enemy soldiers. Yet this is a new form of war, not at all like Desert Storm nor even analogous to Vietnam or Korea.

General Abizaid himself best articulated the current nature of combat in testimony before the U.S. Senate Armed Services Committee on May 19, 2004:

Our enemies are in a unique position, and they are a unique brand of ideological extremists whose vision of the world is best summed up by how the Taliban ran Afghanistan. If they can outlast us in Afghanistan and undermine the legitimate government there, they'll once again fill up the seats at the soccer stadium and force people to watch executions. If, in Iraq, the culture of intimidation practiced by our enemies is allowed to win, the mass graves will fill again. Our enemies kill without remorse, they challenge our will through the careful manipulation of propaganda and information, they seek safe havens in order to develop weapons of mass destruction that they will use against us when they are ready. Their targets are not Kabul and Baghdad, but places like Madrid and London and New York. While we can't be defeated militarily, we're not going to win this thing militarily alone.... As we fight this most unconventional war of this new century, we must be patient and courageous.

In Iraq the U.S. commanders were slow to recognize and adapt to the insurgency that erupted in the summer and fall of 2003. Military police and interrogators who had previous experience in the Balkans, Guantanamo and Afghanistan found themselves, along with increasing numbers of less-experienced troops, in the midst of detention operations in Iraq the likes of which the Department of Defense had not foreseen. As Combined Joint Task Force-7 (CJTF-7) began detaining thousands of Iraqis suspected of

involvement in or having knowledge of the insurgency, the problem quickly surpassed the capacity of the staff to deal with and the wherewithal to contain it.

Line units conducting raids found themselves seizing specifically targeted persons, so designated by military intelligence; but, lacking interrogators and interpreters to make precise distinctions in an alien culture and hostile neighborhoods, they reverted to rounding up any and all suspicious-looking persons—all too often including women and children. The flood of incoming detainees contrasted sharply with the trickle of released individuals. Processing was overwhelmed. Some detainees at Abu Ghraib had been held 90 days before being interrogated for the first time.

Many interrogators, already in short supply from major reductions during the post-Cold War drawdown, by this time, were on their second or third combat tour. Unit cohesion and morale were largely absent as under-strength companies and battalions from across the United States and Germany were deployed piecemeal and stitched together in a losing race to keep up with the rapid influx of vast numbers of detainees.

As the insurgency reached an initial peak in the fall of 2003, many military policemen from the Reserves who had been activated shortly after September 11, 2001 had reached the mandatory two-year limit on their mobilization time. Consequently, the ranks of soldiers having custody of detainees in Iraq fell to about half strength as MPs were ordered home by higher headquarters.

Some individuals seized the opportunity provided by this environment to give vent to latent sadistic urges. Moreover, many well-intentioned professionals, attempting to resolve the inherent moral conflict between using harsh techniques to gain information to save lives and treating detainees humanely, found themselves in uncharted ethical ground, with frequently changing guidance from above. Some stepped over the line of humane treatment accidentally; some did so knowingly. Some of the abusers believed other governmental agencies were conducting interrogations using harsher techniques

INDEPENDENT PANEL TO REVIEW DOD DETENTION OPERATIONS

than allowed by the Army Field Manual 34-52, a perception leading to the belief that such methods were condoned. In nearly 10 percent of the cases of alleged abuse, the chain of command ignored reports of those allegations. More than once a commander was complicit.

The requirements for successful detainee operations following major combat operations were known by U.S. forces in Iraq. After Operations Enduring Freedom and earlier phases of Iraqi Freedom, several lessons learned were captured in official reviews and were available on-line to any authorized military user. These lessons included the need for doctrine tailored to enable police and interrogators to work together effectively; the need for keeping MP and MI units manned at levels sufficient to the task; and the need for MP and MI units to belong to the same tactical command. However, there is no evidence that those responsible for planning and executing detainee operations, in the phase of the Iraq campaign following the major combat operations, availed themselves of these “lessons learned” in a timely fashion.

Judged in a broader context, U.S. detention operations were both traditional and new. They were traditional in that detainee operations were a part of all past conflicts. They were new in that the Global War on Terror and the insurgency we are facing in Iraq present a much more complicated detainee population.

Many of America’s enemies, including those in Iraq and Afghanistan, have the ability to conduct this new kind of warfare, often referred to as “asymmetric” warfare. Asymmetric warfare can be viewed as attempts to circumvent or undermine a superior, conventional strength, while exploiting its weaknesses using methods the superior force neither can defeat nor resort to itself. Small unconventional forces can violate a state’s security without any state support or affiliation whatsoever. For this reason, many terms in the orthodox lexicon of war—e.g., state sovereignty, national borders, uniformed combatants, declarations of war, and even war itself, are not terms terrorists acknowledge.

Today, the power to wage war can rest in the hands of a few dozen highly motivated people with cell phones and access to the Internet. Going beyond simply terrorizing individual civilians, certain insurgent and terrorist organizations represent a higher level of threat, characterized by an ability and willingness to violate the political sovereignty and territorial integrity of sovereign nations.

Essential to defeating terrorist and insurgent threats is the ability to locate cells, kill or detain key leaders, and interdict operational and financial networks. However, the smallness and wide dispersal of these enemy assets make it problematic to focus on signal and imagery intelligence as we did in the Cold War, Desert Storm, and the first phase of Operation Iraqi Freedom. The ability of terrorists and insurgents to blend into the civilian population further decreases their vulnerability to signal and imagery intelligence. Thus, information gained from human sources, whether by spying or interrogation, is essential in narrowing the field upon which other intelligence gathering resources may be applied. In sum, human intelligence is absolutely necessary, not just to fill these gaps in information derived from other sources, but also to provide clues and leads for the other sources to exploit.

Military police functions must also adapt to this new kind of warfare. In addition to organizing more units capable of handling theater-level detention operations, we must also organize those units, so they are able to deal with the heightened threat environment. In this new form of warfare, the distinction between front and rear becomes more fluid. All forces must continuously prepare for combat operations.

THE POLICY PROMULGATION PROCESS

Although there were a number of contributing causes for detainee abuses, policy processes were inadequate or deficient in certain respects at various levels: Department of Defense (DoD), CENTCOM, Coalition Forces Land Component Command (CFLCC), CJTF-7, and the individual holding facility or prison. In pursuing the question of the extent to which policy processes at the DoD or national level contributed to abuses, it is important to begin with policy development as individuals in Afghanistan were first being detained in November 2001. The first detainees arrived at Guantanamo in January 2002.

In early 2002, a debate was ongoing in Washington on the application of treaties and laws to al Qaeda and Taliban. The Department of Justice, Office of Legal Counsel (OLC) advised DoD General Counsel and the Counsel to the President that, among other things:

- Neither the Federal War Crimes Act nor the Geneva Conventions would apply to the detention conditions of al Qaeda prisoners,
- The President had the authority to suspend the United States treaty obligations applying to Afghanistan for the duration of the conflict should he determine Afghanistan to be a failed state,
- The President could find that the Taliban did not qualify for Enemy Prisoner of War (EPW) status under Geneva Convention III.

The Attorney General and the Counsel to the President, in part relying on the opinions of OLC, advised the President to determine the Geneva Conventions did not apply to the conflict with al Qaeda and the Taliban. The Panel understands DoD General Counsel's position was consistent with the Attorney General's and the Counsel to the President's position. Earlier, the Department of State had argued that the Geneva Conventions in their traditional application provided a sufficiently robust legal construct under which the Global War on Terror could effectively be waged.

INDEPENDENT PANEL TO REVIEW DoD DETENTION OPERATIONS

The Legal Advisor to the Chairman, Joint Chiefs of Staff and many service lawyers agreed with the State Department's initial position. They were concerned that to conclude otherwise would be inconsistent with past practice and policy, jeopardize the United States armed forces personnel, and undermine the United States military culture which is based on a strict adherence to the law of war. At the February 4, 2002 National Security Council meeting to decide this issue, the Department of State, the Department of Defense, and the Chairman of the Joint Chiefs of Staff were in agreement that all detainees would get the treatment they are (or would be) entitled to under the Geneva Conventions.

On February 7, 2002, the President issued his decision memorandum (see Appendix B). The memorandum stated the Geneva Conventions did not apply to al Qaeda and therefore they were not entitled to prisoner of war status. It also stated the Geneva Conventions did apply to the Taliban but the Taliban combatants were not entitled to prisoner of war status as a result of their failure to conduct themselves in accordance with the provisions of the Geneva Conventions. The President's memorandum also stated: "As a matter of policy, United States Armed Forces shall continue to treat detainees humanely and, to the extent appropriate and consistent with military necessity, in a manner consistent with the principles of Geneva."

Regarding the applicability of the Convention Against Torture and Other Cruel Inhumane or Degrading Treatment, the OLC opined on August 1, 2002 that interrogation methods that comply with the relevant domestic law do not violate the Convention. It held that only the most extreme acts, that were specifically intended to inflict severe pain and torture, would be in violation; lesser acts might be "cruel, inhumane, or degrading" but would not violate the Convention Against Torture or domestic statutes. The OLC memorandum went on to say, as Commander in Chief exercising his wartime powers, the President could even authorize torture, if he so decided.

Reacting to tenacious resistance by some detainees to existing interrogation methods, which were essentially limited to those in Army Field Manual 34-52 (see Appendix E), Guantanamo authorities in October 2002 requested approval of strengthened counter-interrogation techniques to increase the intelligence yield from interrogations. This request was accompanied by a recommended tiered list of techniques, with the proviso that the harsher Category III methods (see Appendix E) could be used only on “exceptionally resistant detainees” and with approval by higher headquarters.

This Guantanamo initiative resulted in a December 2, 2002 decision by the Secretary of Defense authorizing, “as a matter of policy,” the use of Categories I and II and only one technique in Category III: mild, non-injurious physical contact (see Appendix E). As a result of concern by the Navy General Counsel, the Secretary of Defense rescinded his December approval of all Category II techniques plus the one from Category III on January 15, 2003. This essentially returned interrogation techniques to FM 34-52 guidance. He also stated if any of the methods from Categories II and III were deemed warranted, permission for their use should be requested from him (see Appendix E).

The Secretary of Defense directed the DoD General Counsel to establish a working group to study interrogation techniques. The working group was headed by Air Force General Counsel Mary Walker and included wide membership from across the military, legal and intelligence communities. The working group also relied heavily on the OLC. The working group reviewed 35 techniques, and after a very expansive debate, ultimately recommended 24 to the Secretary of Defense. The study led to the Secretary’s promulgation on April 16, 2003 of the list of approved techniques. His memorandum emphasized appropriate safeguards should be in place and, further, “*Use of these techniques is limited to interrogations of unlawful combatants held at Guantanamo Bay, Cuba.*” He also stipulated that four of the techniques should be used only in case of military necessity and that he should be so notified in advance. If additional techniques were deemed essential, they should be requested in writing, with “recommended safeguards and rationale for applying with an identified detainee.”

INDEPENDENT PANEL TO REVIEW DOD DETENTION OPERATIONS

In the initial development of these Secretary of Defense policies, the legal resources of the Services' Judge Advocates and General Counsels were not utilized to their fullest potential. Had the Secretary of Defense had the benefit of a wider range of legal opinions and a more robust debate regarding detainee policies and operations, his policy of April 16, 2003 might well have been developed and issued in early December 2002. This could have avoided the policy changes which characterized the December 2, 2002 to April 16, 2003 period.

It is clear that pressure for additional intelligence and the more aggressive methods sanctioned by the Secretary of Defense memorandum resulted in stronger interrogation techniques. They did contribute to a belief that stronger interrogation methods were needed and appropriate in their treatment of detainees. At Guantanamo, the interrogators used those additional techniques with only two detainees, gaining important and time-urgent information in the process.

In Afghanistan, from the war's inception through the end of 2002, all forces used FM 34-52 as a baseline for interrogation techniques. Nonetheless, more aggressive interrogation of detainees appears to have been ongoing. On January 24, 2003, in response to a data call from the Joint Staff to facilitate the Secretary of Defense-directed Working Group efforts, the Commander Joint Task Force-180 forwarded a list of techniques being used in Afghanistan, including some not explicitly set out in FM 34-52. These techniques were included in a Special Operations Forces (SOF) Standard Operating Procedures document published in February 2003. The 519th Military Intelligence Battalion, a Company of which was later sent to Iraq, assisted in interrogations in support of SOF and was fully aware of their interrogation techniques.

In Iraq, the operational order from CENTCOM provided the standard FM 34-52 interrogation procedures would be used. Given the greatly different situations in Afghanistan and Iraq, it is not surprising there were differing CENTCOM policies for the

two countries. In light of ongoing hostilities that monopolized commanders' attention in Iraq, it is also not unexpected the detainee issues were not given a higher priority.

Interrogators and lists of techniques circulated from Guantanamo and Afghanistan to Iraq. During July and August 2003, a Company of the 519th MI Battalion was sent to the Abu Ghraib detention facility to conduct interrogation operations. Absent guidance other than FM 34-52, the officer in charge prepared draft interrogation guidelines that were a near copy of the Standard Operating Procedure created by SOF. It is important to note that techniques effective under carefully controlled conditions at Guantanamo became far more problematic when they migrated and were not adequately safeguarded.

In August 2003, MG Geoffrey Miller arrived to conduct an assessment of DoD counterterrorism interrogation and detention operations in Iraq. He was to discuss current theater ability to exploit internees rapidly for actionable intelligence. He brought to Iraq the Secretary of Defense's April 16, 2003 policy guidelines for Guantanamo—which he reportedly gave to CJTF-7 as a potential model—recommending a command-wide policy be established. He noted, however, the Geneva Conventions did apply to Iraq. In addition to these various printed sources, there was also a store of common lore and practice within the interrogator community circulating through Guantanamo, Afghanistan and elsewhere.

At the operational level, in the absence of more specific guidance from CENTCOM, interrogators in Iraq relied on FM 34-52 and on unauthorized techniques that had migrated from Afghanistan. On September 14, 2003, Commander CJTF-7 signed the theater's first policy on interrogation which contained elements of the approved Guantanamo policy and elements of the SOF policy. Policies approved for use on al Qaeda and Taliban detainees who were not afforded the protection of EPW status under the Geneva Conventions now applied to detainees who did fall under the Geneva Convention protections. CENTCOM disapproved the September 14, 2003 policy resulting in another policy signed on October 12, 2003 which essentially mirrored the

INDEPENDENT PANEL TO REVIEW DOD DETENTION OPERATIONS

outdated 1987 version of the FM 34-52. The 1987 version, however, authorized interrogators to control all aspects of the interrogation, "to include lighting and heating, as well as food, clothing, and shelter given to detainees." This was specifically left out of the 1992 version, which is currently in use. This clearly led to confusion on what practices were acceptable. We cannot be sure how much the number and severity of abuses would have been curtailed had there been early and consistent guidance from higher levels. Nonetheless, such guidance was needed and likely would have had a limiting effect.

At Abu Ghraib, the Jones/Fay investigation concluded that MI professionals at the prison level shared a "major part of the culpability" for the abuses. Some of the abuses occurred during interrogation. As these interrogation techniques exceeded parameters of FM 34-52, no training had been developed. Absent training, the interrogators used their own initiative to implement the new techniques. To what extent the same situation existed at other prisons is unclear, but the widespread nature of abuses warrants an assumption that at least the understanding of interrogations policies was inadequate. A host of other possible contributing factors, such as training, leadership, and the generally chaotic situation in the prisons, are addressed elsewhere in this report.

PUBLIC RELEASE OF ABUSE PHOTOS

In any large bureaucracy, good news travels up the chain of command quickly; bad news generally does not. In the case of the abuse photos from Abu Ghraib, concerns about command influence on an ongoing investigation may have impeded notification to senior officials.

Chronology of Events

On January 13, 2004, SPC Darby gave Army criminal investigators a copy of a CD containing abuse photos he had taken from SPC Graner's computer. CJTF-7, CENTCOM, the Chairman of the Joint Chiefs of Staff and the Secretary of Defense were all informed of the issue. LTG Sanchez promptly asked for an outside investigation, and MG Taguba was appointed as the investigating officer. The officials who saw the photos on January 14, 2004, not realizing their likely significance, did not recommend the photos be shown to more senior officials. A CENTCOM press release in Baghdad on January 16, 2004 announced there was an ongoing investigation into reported incidents of detainee abuse at a Coalition Forces detention facility.

An interim report of the investigation was provided to CJTF-7 and CENTCOM commanders in mid-March 2004. It is unclear whether they saw the Abu Ghraib photos, but their impact was not appreciated by either of these officers or their staff officers who may have seen the photographs, as indicated by the failure to transmit them in a timely fashion to more senior officials. When LTG Sanchez received the Taguba report, he immediately requested an investigation into the possible involvement of military intelligence personnel. He told the panel that he did not request the photos be disseminated beyond the criminal investigative process because commanders are prohibited from interfering with, or influencing, active investigations. In mid-April, LTG McKiernan, the appointing official, reported the investigative results through his chain of

INDEPENDENT PANEL TO REVIEW DoD DETENTION OPERATIONS

command to the Department of the Army, the Army Judge Advocate General, and the U.S. Army Reserve Command. LTG McKiernan advised the panel that he did not send a copy of the report to the Secretary of Defense, but forwarded it through his chain of command. Again the reluctance to move bad news farther up the chain of command probably was a factor impeding notification of the Secretary of Defense.

Given this situation, GEN Richard Myers, the Chairman of the Joint Chiefs of Staff, was unprepared in April 2004 when he learned the photos of detainee abuse were to be aired in a CBS broadcast. The planned release coincided with particularly intense fighting by Coalition forces in Fallujah and Najaf. After a discussion with GEN Abizaid, GEN Myers asked CBS to delay the broadcast out of concern the lives of the Coalition soldiers and the hostages in Iraq would be further endangered. The story of the abuse itself was already public. Nonetheless, both GEN Abizaid and GEN Myers understood the pictures would have an especially explosive impact around the world.

Informing Senior Officials

Given the magnitude of this problem, the Secretary of Defense and other senior DoD officials need a more effective information pipeline to inform them of high-profile incidents which may have a significant adverse impact on DoD operations. Had such a pipeline existed, it could have provided an accessible and efficient tool for field commanders to apprise higher headquarters, the Joint Chiefs of Staff, and the Office of the Secretary of Defense, of actual or developing situations which might hinder, impede, or undermine U.S. operations and initiatives. Such a system could have equipped senior spokesmen with the known facts of the situation from all DoD elements involved. Finally, it would have allowed for senior official preparation and Congressional notification.

Such a procedure would make it possible for a field-level command or staff agency to alert others of the situation and forward the information to senior officials. This would not have been an unprecedented occurrence. For example, in December 2002, concerned Naval Criminal Investigative Service agents drew attention to the potential for abuse at Guantanamo. Those individuals had direct access to the highest levels of leadership and were able to get that information to senior levels without encumbrance. While a corresponding flow of information might not have prevented the abuses from occurring, the Office of the Secretary of Defense would have been alerted to a festering issue, allowing for an early and appropriate response.

Another example is the Air Force Executive Issues Team. This office has fulfilled the special information pipeline function for the Air Force since February 1998. The team chief and team members are highly trained and experienced field grade officers drawn from a variety of duty assignments. The team members have access to information flow across all levels of command and staff and are continually engaging and building contacts to facilitate the information flow. The information flow to the team runs parallel and complementary to standard reporting channels in order to avoid bypassing the chain of command but yet ensures a rapid and direct flow of relevant information to Air Force Headquarters.

A proper, transparent posture in getting the facts and fixing the problem would have better enabled the DoD to deal with the damage to the mission of the U.S. in the region and to the reputation of the U.S. military.

COMMAND RESPONSIBILITIES

Although the most egregious instances of detainee abuse were caused by the aberrant behavior of a limited number of soldiers and the predilections of the non-commissioned officers on the night shift of Tier 1 at Abu Ghraib, the Independent Panel finds that commanding officers and their staffs at various levels failed in their duties and that such failures contributed directly or indirectly to detainee abuse. Commanders are responsible for all their units do or fail to do, and should be held accountable for their action or inaction. Command failures were compounded by poor advice provided by staff officers with responsibility for overseeing battlefield functions related to detention and interrogation operations. Military and civilian leaders at the Department of Defense share this burden of responsibility.

Commanders

The Panel finds that the weak and ineffectual leadership of the Commanding General of the 800th MP Brigade and the Commanding Officer of the 205th MI Brigade allowed the abuses at Abu Ghraib. There were serious lapses of leadership in both units from junior non-commissioned officers to battalion and brigade levels. The commanders of both brigades either knew, or should have known, abuses were taking place and taken measures to prevent them. The Panel finds no evidence that organizations above the 800th MP Brigade- or the 205th MI Brigade-level were directly involved in the incidents at Abu Ghraib. Accordingly, the Panel concurs in the judgment and recommendations of MG Taguba, MG Fay, LTG Jones, LTG Sanchez, LTG McKiernan, General Abizaid and General Kern regarding the commanders of these two units. The Panel expects disciplinary action may be forthcoming.

INDEPENDENT PANEL TO REVIEW DOD DETENTION OPERATIONS

The Independent Panel concurs with the findings of MG Taguba regarding the Director of the Joint Interrogation and Debriefing Center (JIDC) at Abu Ghraib. Specifically, the Panel notes that MG Taguba concluded that the Director, JIDC made material misrepresentations to MG Taguba's investigating team. The panel finds that he failed to properly train and control his soldiers and failed to ensure prisoners were afforded the protections under the relevant Geneva Conventions. The Panel concurs with MG Taguba's recommendation that he be relieved for cause and given a letter of reprimand and notes that disciplinary action may be pending against this officer.

The Independent Panel concurs with the findings of MG Taguba regarding the Commander of the 320th MP Battalion at Abu Ghraib. Specifically, the Panel finds that he failed to ensure that his subordinates were properly trained and supervised and that he failed to establish and enforce basic soldier standards, proficiency and accountability. He was not able to organize tasks to accomplish his mission in an appropriate manner. By not communicating standards, policies and plans to soldiers, he conveyed a sense of tacit approval of abusive behavior towards prisoners and a lax and dysfunctional command climate took hold. The Panel concurs with MG Taguba's recommendation that he be relieved from command, be given a General Officer Memorandum of reprimand, and be removed from the Colonel/O-6 promotion list.

The Independent Panel finds that BG Karpinski's leadership failures helped set the conditions at the prison which led to the abuses, including her failure to establish appropriate standard operating procedures (SOPs) and to ensure the relevant Geneva Conventions protections were afforded prisoners, as well as her failure to take appropriate actions regarding ineffective commanders and staff officers. The Panel notes the conclusion of MG Taguba that she made material misrepresentations to his investigating team regarding the frequency of her visits to Abu Ghraib. The Panel concurs with MG Taguba's recommendation that BG Karpinski be relieved of command and given a General Officer Letter of Reprimand.

Although LTG Sanchez had tasks more urgent than dealing personally with command and resource deficiencies and allegations of abuse at Abu Ghraib, he should have ensured his staff dealt with the command and resource problems. He should have assured that urgent demands were placed for appropriate support and resources through Coalition Forces Land Component Command (CFLCC) and CENTCOM to the Joint Chiefs of Staff. He was responsible for establishing the confused command relationship at the Abu Ghraib prison. There was no clear delineation of command responsibilities between the 320th MP Battalion and the 205th MI Brigade. The situation was exacerbated by CJTF-7 Fragmentary Order (FRAGO) 1108 issued on November 19, 2003 that appointed the commander of the 205th MI Brigade as the base commander for Abu Ghraib, including responsibility for the support of all MPs assigned to the prison. In addition to being contrary to existing doctrine, there is no evidence the details of this command relationship were effectively coordinated or implemented by the leaders at Abu Ghraib. The unclear chain of command established by CJTF-7, combined with the poor leadership and lack of supervision, contributed to the atmosphere at Abu Ghraib that allowed the abuses to take place.

The unclear command structure at Abu Ghraib was further exacerbated by the confused command relationship up the chain. The 800th MP Brigade was initially assigned to the Central Command's Combined Forces Land Component Commander (CFLCC) during the major combat phase of Operation Iraqi Freedom. When CFLCC left the theater and returned to Fort McPherson Georgia, CENTCOM established Combined Joint Task Force-Seven (CJTF-7). While the 800th MP Brigade remained assigned to CFLCC, it essentially worked for CJTF-7. LTG Sanchez delegated responsibility for detention operations to his Deputy, MG Wojdakowski. At the same time, intelligence personnel at Abu Ghraib reported through the CJTF-7 C-2, Director for Intelligence. These arrangements had the damaging result that no single individual was responsible for overseeing operations at the prison.

INDEPENDENT PANEL TO REVIEW DOD DETENTION OPERATIONS

The Panel endorses the disciplinary actions already taken, although we believe LTG Sanchez should have taken more forceful action in November when he fully comprehended the depth of the leadership problems at Abu Ghraib. His apparent attempt to mentor BG Karpinski, though well-intended, was insufficient in a combat zone in the midst of a serious and growing insurgency.

The creation of the Joint Interrogation and Debriefing Center (JIDC) at Abu Ghraib was not an unusual organizational approach. The problem is, as the Army Inspector General assessment revealed, joint doctrine for the conduct of interrogation operations contains inconsistent guidance, particularly with regard to addressing the issue of the appropriate command relationships governing the operation of such organizations as a JIDC. Based on the findings of the Fay, Jones and Church investigations, SOUTHCOM and CENTCOM were able to develop effective command relationships for such centers at Guantanamo and in Afghanistan, but CENTCOM and CJTF-7 failed to do so for the JIDC at Abu Ghraib.

Staff Officers

While staff officers have no command responsibilities, they are responsible for providing oversight, advice and counsel to their commanders. Staff oversight of detention and interrogation operations for CJTF-7 was dispersed among the principal and special staff. The lack of one person on the staff to oversee detention operations and facilities complicated effective and efficient coordination among the staff.

The Panel finds the following:

- The CJTF-7 Deputy Commander failed to initiate action to request additional military police for detention operations after it became clear that there were insufficient assets in Iraq.
- The CJTF-7 C-2, Director for Intelligence failed to advise the commander properly on directives and policies needed for the operation of the JIDC, for interrogation techniques and for appropriately monitoring the activities of Other Government Agencies (OGAs) within the Joint Area of Operations.
- The CJTF-7 Staff Judge Advocate failed to initiate an appropriate response to the November 2003 ICRC report on the conditions at Abu Ghraib.

Failure of the Combatant Command to Adjust the Plan

Once it became clear in July 2003 there was a major insurgency growing in Iraq and the relatively benign environment projected for Iraq was not materializing, senior leaders should have adjusted the plan from what had been assumed to be a stability operation and a benign handoff of detention operations to the Iraqis. If commanders and staffs at the operational level had been more adaptive in the face of changing conditions, a different approach to detention operations could have been developed by October 2003, as difficulties with the basic plan were readily apparent by that time. Responsible leaders who could have set in motion the development of a more effective alternative course of action extend up the command chain (and staff), to include the Director for Operations, Combined Joint Task Force 7 (CJTF-7); Deputy Commanding General, CJTF-7; Commander CJTF-7; Deputy Commander for Support, CFLCC; Commander, CFLCC; Director for Operations, Central Command (CENTCOM); Commander, CENTCOM; Director for Operations, Joint Staff; the Chairman of the Joint Chiefs of Staff; and the Office of the Secretary of Defense. In most cases these were errors of omission, but they were errors that should not go unnoted.

INDEPENDENT PANEL TO REVIEW DOD DETENTION OPERATIONS

There was ample evidence in both Joint and Army lessons learned that planning for detention operations for Iraq required alternatives to standard doctrinal approaches. Reports from experiences in Operation Enduring Freedom and at Guantanamo had already recognized the inadequacy of current doctrine for the detention mission and the need for augmentation of both MP and MI units with experienced confinement officers and interrogators. Previous experience also supported the likelihood that detainee population numbers would grow beyond planning estimates. The relationship between MP and MI personnel in the conduct of interrogations also demanded close, continuous coordination rather than remaining compartmentalized. "Lessons learned" also reported the value of establishing a clear chain of command subordinating MP and MI to a Joint Task Force or Brigade Commander. This commander would be in charge of all aspects of both detention and interrogations just as tactical combat forces are subordinated to a single commander. The planners had only to search the lessons learned databases (available on-line in military networks) to find these planning insights. Nevertheless, CENTCOM's October 2002 planning annex for detention operations reflected a traditional doctrinal methodology.

The change in the character of the struggle signaled by the sudden spike in U.S. casualties in June, July and August 2003 should have prompted consideration of the need for additional MP assets. GEN Abizaid himself signaled a change in operations when he publicly declared in July that CENTCOM was now dealing with a growing "insurgency," a term government officials had previously avoided in characterizing the war. Certainly by October and November when the fighting reached a new peak, commanders and staffs from CJTF-7 all the way to CENTCOM and the Joint Chiefs of Staff knew by then the serious deficiencies of the 800th MP Brigade and should have at least considered reinforcing the troops for detention operations. Reservists, some of whom had been first mobilized shortly after September 11, 2001, began reaching a two-year mobilization commitment, which, by law, mandated their redeployment and deactivation.

There was not much the 800th MP Brigade (an Army Reserve unit), could do to delay the loss of those soldiers, and there was no individual replacement system or a unit replacement plan. The MP Brigade was totally dependent on higher headquarters to initiate action to alleviate the personnel crisis. The brigade was duly reporting readiness shortfalls through appropriate channels. However, its commanding general was emphasizing these shortfalls in personal communications with CJTF-7 commanders and staff as opposed to CFLCC. Since the brigade was assigned to CFLCC, but under the Tactical Control (TACON) of CJTF-7, her communications should have been with CFLCC. The response from CJTF-7's Commander and Deputy Commander was that the 800th MP Brigade had sufficient personnel to accomplish its mission and that it needed to reallocate its available soldiers among the dozen or more detention facilities it was operating in Iraq. However, the Panel found the further deterioration in the readiness condition of the brigade should have been recognized by CFLCC and CENTCOM by late summer 2003. This led the Panel to conclude that CJTF-7, CFLCC and CENTCOM failure to request additional forces was an avoidable error.

The Joint Staff recognized intelligence collection from detainees in Iraq needed improvement. This was their rationale for sending MG Miller from Guantanamo to assist CJTF-7 with interrogation operations. However, the Joint Staff was not paying sufficient attention to evidence of broader readiness issues associated with both MP and MI resources.

We note that CJTF-7 Headquarters was never fully resourced to meet the size and complexity of its mission. The Joint Staff, CJTF-7 and CENTCOM took too long to finalize the Joint Manning Document (JMD) which was not finally approved until December 2003—six months into the insurgency. At one point, CJTF-7 Headquarters had only 495 of the 1,400 personnel authorized. The command was burdened with additional complexities associated with its mission to support the Coalition Provisional Authority.

INDEPENDENT PANEL TO REVIEW DOD DETENTION OPERATIONS

Finally, the Joint Staff failed to recognize the implications of the deteriorating manning levels in the 800th MP Brigade; the absence of combat equipment among detention elements of MP units operating in a combat zone; and the indications of deteriorating mission performance among military intelligence interrogators owing to the stress of repeated combat deployments.

When CJTF-7 did realize the magnitude of the detention problem, it requested an assistance visit by the Provost Marshal General of the Army, MG Ryder. There seemed to be some misunderstanding of the CJTF-7 intent, however, since MG Ryder viewed his visit primarily as an assessment of how to transfer the detention program to the Iraqi prison system.

In retrospect, several options for addressing the detention operations challenge were available. CJTF-7 could have requested a change in command relationships to place the 800th MP Brigade under Operational Control of CJTF-7 rather than Tactical Control. This would have permitted the Commander of CJTF-7 to reallocate tactical assets under his control to the detention mission. While other Military Police units in Iraq were already fully committed to higher-priority combat and combat support missions, such as convoy escort, there were non-MP units that could have been reassigned to help in the conduct of detention operations. For example, an artillery brigade was tasked to operate the CJTF-7 Joint Visitors Center in Baghdad. A similar tasking could have provided additional troop strength to assist the 800th MP Brigade at Abu Ghraib. Such a shift would have supplied valuable experienced sergeants, captains and lieutenant colonels sorely lacking in both the MI and MP units at Abu Ghraib. A similar effect could have been achieved by CENTCOM assigning USMC, Navy and Air Force MP and security units to operational control of CJTF-7 for the detention operations mission.

Mobilization and deployment of additional forces from CONUS was also a feasible option. A system is in place for commands such as CJTF-7, CFLCC, and CENTCOM to submit a formal Request for Forces (RFF). Earlier, CJTF-7 had submitted a RFF for an

additional Judge Advocate organization, but CENTCOM would not forward it to the Joint Chiefs of Staff. Perhaps this experience made CJTF-7 reluctant to submit a RFF for MP units, but there is no evidence that any of the responsible officers considered any option other than the response given to BG Karpinski to "wear her stars" and reallocate personnel among her already over-stretched units.

While it is the responsibility of the JCS and services to provide adequate numbers of appropriately trained personnel for missions such as the detention operations in Iraq, it is the responsibility of the combatant commander to organize those forces in a manner to achieve mission success. The U.S. experience in the conduct of post-conflict stability operations has been limited, but the impact of our failure to conduct proper detainee operations in this case has been significant. Combatant commanders and their subordinates must organize in a manner that affords unity of command, ensuring commanders work for commanders and not staff.

The fact that the detention operation mission for all of Iraq is now commanded by a 2-star general who reports directly to the operational commander, and that 1,900 MPs, more appropriately equipped for combat, now perform the mission once assigned to a single under-strength, poorly trained, inadequately equipped, and weakly-led brigade, indicate more robust options should have been considered sooner.

Finally, the panel notes the failure to report the abuses up the chain of command in a timely manner with adequate urgency. The abuses at Abu Ghraib were known and under investigation as early as January 2004. However, the gravity of the abuses was not conveyed up the chain of command to the Secretary of Defense. The Taguba report, including the photographs, was completed in March 2004. This report was transmitted to LTG Sanchez and GEN Abizaid; however, it is unclear whether they ever saw the Abu Ghraib photos. GEN Myers has stated he knew of the existence of the photos as early as January 2004. Although the knowledge of the investigation into Abu Ghraib was widely known, as we noted in the previous section, the impact of the photos was not appreciated

INDEPENDENT PANEL TO REVIEW DoD DETENTION OPERATIONS

by any of these officers as indicated by the failure to transmit them in a timely fashion to officials at the Department of Defense. (See Appendix A for the names of persons associated with the positions cited in this section.)

MILITARY POLICE AND DETENTION OPERATIONS

In Operation Enduring Freedom in Afghanistan and Operation Iraqi Freedom, commanders should have paid greater attention to the relationship between detainees and military operations. The current doctrine and procedures for detaining personnel are inadequate to meet the requirements of these conflicts. Due to the vastly different circumstances in these conflicts, it should not be surprising there were deficiencies in the projected needs for military police forces. All the investigations the Panel reviewed highlight the urgency to augment the prior way of conducting detention operations. In particular, the military police were not trained, organized, or equipped to meet the new challenges.

The Army IG found morale was high and command climate was good throughout forces deployed in Iraq and Afghanistan with one noticeable exception. Soldiers conducting detainee operations in remote or dangerous locations complained of very poor morale and command climate due to the lack of higher command involvement and support and the perception that their leaders did not care. At Abu Ghraib, in particular, there were many serious problems, which could have been avoided, if proper guidance, oversight and leadership had been provided.

Mobilization and Training

Mobilization and training inadequacies for the MP units occurred during the various phases of employment, beginning with peacetime training, activation, arrival at the mobilization site, deployment, arrival in theater and follow-on operations.

INDEPENDENT PANEL TO REVIEW DOD DETENTION OPERATIONS

Mobilization and Deployment

Problems generally began for the MP units upon arrival at the mobilization sites. As one commander stated, "Anything that could go wrong went wrong." Preparation was not consistently applied to all deploying units, wasting time and duplicating efforts already accomplished. Troops were separated from their equipment for excessive periods of time. The flow of equipment and personnel was not coordinated. The Commanding General of the 800th MP Brigade indicated the biggest problem was getting MPs and their equipment deployed together. The unit could neither train at its stateside mobilization site without its equipment nor upon arrival overseas, as two or three weeks could go by before joining with its equipment. This resulted in assigning equipment and troops in an ad hoc manner with no regard to original unit. It also resulted in assigning certain companies that had not trained together in peacetime to battalion headquarters. The flow of forces into theater was originally planned and assigned on the basis of the Time Phased Force Deployment List (TPFDL). The TPFDL was soon scrapped, however, in favor of individual unit deployment orders assigned by U.S. Army Forces Command based on unit readiness and personnel strength. MP Brigade commanders did not know who would be deployed next. This method resulted in a condition wherein a recently arrived battalion headquarters would be assigned the next arriving MP companies, regardless of their capabilities or any other prior command and training relationships.

Original projections called for approximately 12 detention facilities with a projection of 30,000 to 100,000 enemy prisoners of war. These large projections did not materialize. In fact, the initial commanding general of the 800th MP brigade, BG Hill, stated he had more than enough MPs designated for the Internment/Resettlement (I/R—hereafter called detention) mission at the end of the combat phase in Iraq. This assessment radically changed following the major combat phase, when the 800th moved to Baghdad beginning in the summer of 2003 to assume the detention mission. The brigade was given additional tasks assisting the Coalition Provisional Authority (CPA) in reconstructing the Iraqi corrections system, a mission they had neither planned for nor anticipated.

Inadequate Training for the Military Police Mission

Though some elements performed better than others, generally training was inadequate. The MP detention units did not receive detention-specific training during their mobilization period, which was a critical deficiency. Detention training was conducted for only two MP detention battalions, one in Afghanistan and elements of the other at Camp Arifjan, Kuwait. The 800th MP Brigade, prior to deployment, had planned for a major detention exercise during the summer of 2002; however, this was cancelled due to the activation of many individuals and units for Operation Noble Eagle following the September 11, 2001 attack. The Deputy Commander of one MP brigade stated "training at the mobilization site was wholly inadequate." In addition, there was no theater-specific training.

The Army Inspector General's investigators also found that training at the mobilization sites failed to prepare units for conducting detention operations. Leaders of inspected reserve units stated in interviews that they did not receive a clear mission statement prior to mobilization and were not notified of their mission until after deploying. Personnel interviewed described being placed immediately in stressful situations in a detention facility with thousands of non-compliant detainees and not being trained to handle them. Units arriving in theater were given just a few days to conduct a handover from the outgoing units. Once deployed, these newly arrived units had difficulty gaining access to the necessary documentation on tactics, techniques, and procedures to train their personnel on the MP essential tasks of their new mission. A prime example is that relevant Army manuals and publications were available only on-line, but personnel did not have access to computers or the Internet.

INDEPENDENT PANEL TO REVIEW DOD DETENTION OPERATIONS

Force Structure Organization

The current military police organizational structure does not address the detention mission on the nonlinear battlefield characteristic of the Global War on Terror.

Current Military Police Structure

The present U.S. Army Reserve and Army National Guard system worked well for the 1991 Gulf War for which large numbers of reserve forces were mobilized, were deployed, fought, and were quickly returned to the United States. These forces, however, were not designed to maintain large numbers of troops at a high operational tempo for a long period of deployment as has been the case in Afghanistan and Iraq.

Comments from commanders and the various inspection reports indicated the current force structure for the MPs is neither flexible enough to support the developing mission, nor can it provide for the sustained detainee operations envisioned for the future. The primary reason is that the present structure lacks sufficient numbers of detention specialists. Currently, the Army active component detention specialists are assigned in support of the Disciplinary Barracks and Regional Correctional Facilities in the United States, all of which are non-deployable.

New Force Structure Initiatives

Significant efforts are currently being made to shift more of the MP detention requirements into the active force structure. The Army's force design for the future will standardize detention forces between active and reserve components and provide the capability for the active component to immediately deploy detention companies.

The Panel notes that the Mikolashek inspection found significant shortfalls in training and force structure for field sanitation, preventive medicine and medical treatment requirements for detainees.

Doctrine and Planning

Initial planning envisaged a conflict mirroring operation Desert Storm; approximately 100,000 enemy prisoners of war were forecast for the first five days of the conflict. This expectation did not materialize in the first phase of Operation Iraqi Freedom. As a result, there were too many MP detention companies. The reverse occurred in the second phase of Iraqi Freedom, where the plan envisaged a reduced number of detention MPs on the assumption the initial large numbers of enemy prisoners of war would already have been processed out of the detention facilities. The result was that combat MPs were ultimately reassigned to an unplanned detention mission.

The doctrine of yesterday's battlefield does not satisfy the requirements of today's conflicts. Current doctrine assumes a linear battlefield and is very clear for the handling of detainees from the point of capture to the holding areas and eventually to the detention facilities in the rear. However, Operations Enduring Freedom and Iraqi Freedom, both occurring where there is no distinction between front and rear areas, forced organizations to adapt tactics and procedures to address the resulting voids. Organizations initially used standard operating procedures for collection points and detention facilities. These procedures do not fit the new environment, generally because there are no safe areas behind "friendly lines" – *there are* no friendly lines. The inapplicability of current doctrine had a negative effect on accountability, security, safeguarding of detainees, and intelligence exploitation. Instead of capturing and rapidly moving detainees to secure collection points as prescribed by doctrine, units tended to retain the detainees and attempted to exploit their tactical intelligence value without the required training or infrastructure.

INDEPENDENT PANEL TO REVIEW DOD DETENTION OPERATIONS

Current doctrine specifies that line combat units hold detainees no longer than 12 – 24 hours to extract immediately useful intelligence. Nonetheless, the Army IG inspection found detainees were routinely held up to 72 hours. For corps collection points, doctrine specifies detainees be held no longer than three days; the Army IG found detainees were held from 30 to 45 days.

Equipment Shortfalls

The current force structure for MP detention organizations does not provide sufficient assets to meet the inherent force protection requirement on battlefields likely to be characteristic of the future. Detention facilities in the theater may have to be located in a hostile combat zone, instead of the benign secure environment current doctrine presumes.

MP detention units will need to be equipped for combat. Lack of crew-served weapons, e.g., machine guns and mortars, to counter external attacks resulted in casualties to the detainee population as well as to the friendly forces. Moreover, Army-issued radios were frequently inoperable and too few in number. In frustration, individual soldiers purchased commercial radios from civilian sources. This improvisation created an unsecured communications environment that could be monitored by any hostile force outside the detention facility.

Detention Operations and Accountability

Traditionally, military police support the Joint Task Force (JTF) by undertaking administrative processing of detention operations, thereby relieving the war-fighters of concern over prisoners and civilian detainees. The handling of detainees is a tactical and operational consideration the JTF addresses during planning to prevent combat forces from being diverted to handle large numbers of detainees. Military police are structured,

therefore, to facilitate the tempo of combat operations by providing for the quick movement of prisoners from the battle area to temporary holding areas and thence to detention facilities.

However, the lack of relevant doctrine meant the design and operation of division, battalion, and company collection points were improvised on an ad hoc basis, depending on such immediate local factors as mission, troops available, weather, time, etc. At these collection points, the SOPs the units had prior to deployment were outdated or ill-suited for the operating environment of Afghanistan and Iraq. Tactical units found themselves taking on roles in detainee operations never anticipated in their prior training. Such lack of proper skills had a negative effect on the intelligence exploitation, security, and safeguarding of detainees.

The initial point of capture may be at any time or place in a military operation. This is the place where soldiers have the least control of the environment and where most contact with the detainees occurs. It is also the place where, in or immediately after battle, abuse may be most likely. And it is the place where the detainee, shocked by capture, may be most likely to give information. As noted earlier, instead of capturing and rapidly transporting detainees to collection points, battalions and companies were holding detainees for excessive periods, even though they lacked the training, materiel, or infrastructure for productive interrogation. The Naval IG found that approximately one-third of the alleged incidents of abuse occurred at the point of capture.

Detention

The decision to use Abu Ghraib as the primary operational level detention facility happened by default. Abu Ghraib was selected by Ambassador Bremer who envisioned it as a temporary facility to be used for criminal detainees until the new Iraqi government could be established and an Iraqi prison established at another site. However, CJTF-7 saw an opportunity to use it as an interim site for the detainees it expected to round up as

INDEPENDENT PANEL TO REVIEW DOD DETENTION OPERATIONS

part of Operation Victory Bounty in July 2003. CJTF-7 had considered Camp Bucca but rejected it, as it was 150 miles away from Baghdad where the operation was to take place.

Abu Ghraib was also a questionable facility from a standpoint of conducting interrogations. Its location, next to an urban area, and its large size in relation to the small MP unit tasked to provide a law enforcement presence, made it impossible to achieve the necessary degree of security. The detainee population of approximately 7,000 out-manned the 92 MPs by approximately a 75:1 ratio. The choice of Abu Ghraib as the facility for detention operations placed a strictly detention mission-driven unit—one designed to operate in a rear area—smack in the middle of a combat environment.

Detainee Accountability and Classification

Adequate procedures for accountability were lacking during the movement of detainees from the collection points to the detainee facilities. During the movement, it was not unusual for detainees to exchange their identification tags with those of other detainees. The diversity of the detainee population also made identification and classification difficult. Classification determined the detainee assignment to particular cells/blocks, but individuals brought to the facility were often a mix of criminals and security detainees. The security detainees were either held for their intelligence value or presented a continuing threat to Coalition Forces. Some innocents were also included in the detainee population. The issue of unregistered or “ghost” detainees presented a limited, though significant, problem of accountability at Abu Ghraib.

Detainee Reporting

Detainee reporting lacked accountability, reliability and standardization. There was no central agency to collect and manage detainee information. The combatant commanders

and the JTF commanders have overall responsibility for the detainee programs to ensure compliance with the international law of armed conflict, domestic law and applicable national policy and directives. The reporting system is supposed to process all inquiries concerning detainees and provide accountability information to the International Committee of the Red Cross. The poor reporting system did not meet this obligation.

Release Procedures

Multiple reviews were required to make release recommendations prior to approval by the release authority. Nonconcurrency by area commanders, intelligence organizations, or law enforcement agencies resulted in retention of ever larger numbers of detainees. The Army Inspector General estimated that up to 80 percent of detainees being held for security and intelligence reasons might be eligible for release upon proper review of their cases with the other 20 percent either requiring continued detention on security grounds or uncompleted intelligence requirements. Interviews indicated area commanders were reluctant to concur with release decisions out of concern that potential combatants would be reintroduced into their areas of operation or that the detainees had continuing intelligence value.

INTERROGATION OPERATIONS

Any discussion of interrogation techniques must begin with the simple reality that their purpose is to gain intelligence that will help protect the United States, its forces and interests abroad. The severity of the post-September 11, 2001 terrorist threat and the escalating insurgency in Iraq make information gleaned from interrogations especially important. When lives are at stake, all legal and moral means of eliciting information must be considered. Nonetheless, interrogations are inherently unpleasant, and many people find them objectionable by their very nature.

The relationship between interrogators and detainees is frequently adversarial. The interrogator's goal of extracting useful information likely is in direct opposition to the detainee's goal of resisting or dissembling. Although interrogators are trained to stay within the bounds of acceptable conduct, the imperative of eliciting timely and useful information can sometimes conflict with proscriptions against inhumane or degrading treatment. For interrogators in Iraq and Afghanistan, this tension is magnified by the highly stressful combat environment. The conditions of war and the dynamics of detainee operations carry inherent risks for human mistreatment and must be approached with caution and careful planning and training.

A number of interrelated factors both limited the intelligence derived from interrogations and contributed to detainee abuse in Operations Enduring Freedom and Iraqi Freedom. A shortfall of properly trained human intelligence personnel to do tactical interrogation of detainees existed at all levels. At the larger detention centers, qualified and experienced interrogators and interpreters were in short supply. No doctrine existed to cover segregation of detainees whose status differed or was unclear, nor was there guidance on timely release of detainees no longer deemed of intelligence interest. The failure to adapt rapidly to the new intelligence requirements of the Global War on Terror resulted in inadequate resourcing, inexperienced and untrained personnel, and a backlog of detainees

INDEPENDENT PANEL TO REVIEW DOD DETENTION OPERATIONS

destined for interrogation. These conditions created a climate not conducive to sound intelligence-gathering efforts.

The Threat Environment

The Global War on Terror requires a fundamental reexamination of how we approach collecting intelligence. Terrorists present new challenges because of the way they organize, communicate, and operate. Many of the terrorists and insurgents are geographically dispersed non-state actors who move across national boundaries and operate in small cells that are difficult to surveil and penetrate.

Human Intelligence from Interrogations

The need for human intelligence has dramatically increased in the new threat environment of asymmetric warfare. Massed forces and equipment characteristic of the Cold War era, Desert Storm and even Phase I of Operation Iraqi Freedom relied largely on signals and imagery intelligence. The intelligence problem then was primarily one of monitoring known military sites, troop locations and equipment concentrations. The problem today, however, is discovering new information on widely dispersed terrorist and insurgent networks. Human intelligence often provides the clues to understand these networks, enabling the collection of intelligence from other sources. Information derived from interrogations is an important component of this human intelligence, especially in the Global War on Terror.

The interrogation of al Qaeda members held at Guantanamo has yielded valuable information used to disrupt and preempt terrorist planning and activities. Much of the 9/11 Commission's report on the planning and execution of the attacks on the World Trade Center and Pentagon came from interrogation of detainees. In the case of

al Qaeda, interrogations provided insights on organization, key personnel, target selection, planning cycles, cooperation among various groups, and logistical support. This information expanded our knowledge of the selection, motivation, and training of these groups. According to Congressional testimony by the Under Secretary of Defense for Intelligence, we have gleaned information on a wide range of al Qaeda activities, including efforts to obtain weapons of mass destruction, sources of finance, training in use of explosives and suicide bombings, and potential travel routes to the United States.

Interrogations provide commanders with information about enemy networks, leadership, and tactics. Such information is critical in planning operations. Tactically, detainee interrogation is a fundamental tool for gaining insight into enemy positions, strength, weapons, and intentions. Thus, it is fundamental to the protection of our forces in combat. Notably, Saddam Hussein's capture was facilitated by interrogation-derived information. Interrogations often provide fragmentary pieces of the broader intelligence picture. These pieces become useful when combined with other human intelligence or intelligence from other sources.

Pressure on Interrogators to Produce Actionable Intelligence

With the active insurgency in Iraq, pressure was placed on the interrogators to produce "actionable" intelligence. In the months before Saddam Hussein's capture, inability to determine his whereabouts created widespread frustration within the intelligence community. With lives at stake, senior leaders expressed, forcibly at times, their needs for better intelligence. A number of visits by high-level officials to Abu Ghraib undoubtedly contributed to this perceived pressure. Both the CJTF-7 commander and his intelligence officer, CJTF-7 C2, visited the prison on several occasions. MG Miller's visit in August/September, 2003 stressed the need to move from simply collecting tactical information to collecting information of operational and strategic value. In November

INDEPENDENT PANEL TO REVIEW DOD DETENTION OPERATIONS

2003, a senior member of the National Security Council Staff visited Abu Ghraib, leading some personnel at the facility to conclude, perhaps incorrectly, that even the White House was interested in the intelligence gleaned from their interrogation reports. Despite the number of visits and the intensity of interest in actionable intelligence, however, the Panel found no undue pressure exerted by senior officials. Nevertheless, their eagerness for intelligence may have been perceived by interrogators as pressure.

Interrogation Operations Issues

A number of factors contributed to the problems experienced in interrogation operations. They ranged from resource and leadership shortfalls to doctrinal deficiencies and poor training.

Inadequate Resources

As part of the peace dividend following the Cold War much of the human intelligence capability, particularly in the Army, was reduced. As hostilities began in Afghanistan and Iraq, Army human intelligence personnel, particularly interrogators and interpreters, were ill-equipped to deal with requirements at both the tactical level and at the larger detention centers. At the tactical level, questioning of detainees has been used in all major conflicts. Knowledge of the enemy's positions, strength, equipment and tactics is critical in order to achieve operational success while minimizing casualties. Such tactical questioning to gain immediate battlefield intelligence is generally done at or near the point of capture. In Iraq, although their numbers were insufficient, some of the more seasoned MIs from the MI units supporting Abu Ghraib were assigned to support the Army Tactical HUMINT teams in the field.

In both Afghanistan and Iraq, tactical commanders kept detainees longer than specified by doctrine in order to exploit their unique local knowledge such as religious and tribal affiliation and regional politics. Remaining with the tactical units, the detainees could be

available for follow-up questioning and clarification of details. The field commanders were concerned that information from interrogations, obtained in the more permanent facilities, would not be returned to the capturing unit. Tactical units, however, were not properly resourced to implement this altered operating arrangement. The potential for abuse also increases when interrogations are conducted in an emotionally charged field environment by personnel unfamiliar with approved techniques.

At the fixed detention centers such as Abu Ghraib, lack of resources and shortage of more experienced senior interrogators impeded the production of actionable intelligence. Inexperienced and untrained personnel often yielded poor intelligence. Interpreters, particularly, were in short supply, contributing to the backlog of detainees to be interrogated. As noted previously, at Abu Ghraib for instance, there were detainees who had been in custody for as long as 90 days before being interrogated for the first time.

Leadership and Organization Shortfalls at Abu Ghraib

Neither the leadership nor the organization of Military Intelligence at Abu Ghraib was up to the mission. The 205th MI Brigade had no organic interrogation elements; they had been eliminated by the downsizing in the 1990s. Soldiers from Army Reserve units filled the ranks, with the consequence that the Brigade Commander had to rely on disparate elements of units and individuals, including civilians, which had never trained together. The creation of the Joint Interrogation and Debriefing Center (JIDC) introduced another layer of complexity into an already stressed interrogations environment. The JIDC was an ad hoc organization made up of six different units lacking the normal command and control structure, particularly at the senior noncommissioned officer level. Leadership was also lacking, from the Commander of the 800th MP Brigade in charge of Abu Ghraib, who failed to ensure that soldiers had appropriate SOPs for dealing with detainees, to the Commander of the 205th MI Brigade, who failed to ensure that soldiers under his command were properly trained and followed the interrogation rules of engagement. Moreover, the Director of the JIDC was a weak leader who did not have experience in

INDEPENDENT PANEL TO REVIEW DOD DETENTION OPERATIONS

interrogation operations and who ceded the core of his responsibilities to subordinates. He failed to provide appropriate training and supervision of personnel assigned to the Center. None of these leaders established the basic standards and accountability that might have served to prevent the abusive behaviors that occurred.

Interrogation Techniques

Interrogation techniques intended only for Guantanamo came to be used in Afghanistan and Iraq. Techniques employed at Guantanamo included the use of stress positions, isolation for up to 30 days and removal of clothing. In Afghanistan techniques included removal of clothing, isolating people for long periods of time, use of stress positions, exploiting fear of dogs, and sleep and light deprivation. Interrogators in Iraq, already familiar with some of these ideas, implemented them even prior to any policy guidance from CJTF-7. Moreover, interrogators at Abu Ghraib were relying on a 1987 version of FM 34-52, which authorized interrogators to control all aspects of the interrogation to include light, heating, food, clothing and shelter given to detainees.

A range of opinion among interrogators, staff judge advocates and commanders existed regarding what techniques were permissible. Some incidents of abuse were clearly cases of individual criminal misconduct. Other incidents resulted from misinterpretations of law or policy or confusion about what interrogation techniques were permitted by law or local SOPs. The incidents stemming from misinterpretation or confusion occurred for several reasons: the proliferation of guidance and information from other theaters of operation; the interrogators' experiences in other theaters; and the failure to distinguish between permitted interrogation techniques in other theater environments and Iraq. Some soldiers or contractors who committed abuse may honestly have believed the techniques were condoned.

Use of Contractors as Interrogators

As a consequence of the shortage of interrogators and interpreters, contractors were used to augment the workforce. Contractors were a particular problem at Abu Ghraib. The Army Inspector General found that 35 percent of the contractors employed did not receive formal training in military interrogation techniques, policy, or doctrine. The Naval Inspector General, however, found some of the older contractors had backgrounds as former military interrogators and were generally considered more effective than some of the junior enlisted military personnel. Oversight of contractor personnel and activities was not sufficient to ensure intelligence operations fell within the law and the authorized chain of command. Continued use of contractors will be required, but contracts must clearly specify the technical requirements and personnel qualifications, experience, and training needed. They should also be developed and administered in such a way as to provide the necessary oversight and management.

Doctrinal Deficiencies

At the tactical level, detaining individuals primarily for intelligence collection or because they constitute a potential security threat, though necessary, presents units with situations not addressed by current doctrine. Many units adapted their operating procedures for conducting detainee operations to fit an environment not contemplated in the existing doctrinal manuals. The capturing units had no relevant procedures for information and evidence collection, which were critical for the proper disposition of detainees.

Additionally, there is inconsistent doctrine on interrogation facility operations for the fixed detention locations. Commanders had to improvise the organization and command relationships within these elements to meet the particular requirements of their operating environments in Afghanistan and Iraq. Doctrine is lacking to address the screening and interrogation of large numbers of detainees whose status (combatants, criminals, or innocents) is not easily ascertainable. Nor does policy specifically address administrative

INDEPENDENT PANEL TO REVIEW DoD DETENTION OPERATIONS

responsibilities related to the timely release of detainees captured and detained primarily for intelligence exploitation or for the security threat they may pose.

Role of CIA

CIA personnel conducted interrogations in DoD detention facilities. In some facilities these interrogations were conducted in conjunction with military personnel, but at Abu Ghraib the CIA was allowed to conduct its interrogations separately. No memorandum of understanding existed on interrogations operations between the CIA and CJTF-7, and the CIA was allowed to operate under different rules. According to the Fay investigation, the CIA's detention and interrogation practices contributed to a loss of accountability at Abu Ghraib. We are aware of the issue of unregistered detainees, but the Panel did not have sufficient access to CIA information to make any determinations in this regard.

THE ROLE OF MILITARY POLICE AND MILITARY INTELLIGENCE IN DETENTION OPERATIONS

Existing doctrine does not clearly address the relationship between the Military Police (MP) operating detention facilities and Military Intelligence (MI) personnel conducting intelligence exploitation at those facilities. The Army Inspector General report states neither MP nor MI doctrine specifically defines the distinct, but interdependent, roles and responsibilities of the two elements in detainee operations.

In the Global War on Terror, we are dealing with new conditions and new threats. Doctrine must be adjusted accordingly. MP doctrine currently states intelligence personnel may collaborate with MPs at detention sites to conduct interrogations, with coordination between the two groups to establish operating procedures. MP doctrine does not, however, address the subject of approved and prohibited MI procedures in an MP-operated facility. Conversely, MI doctrine does not clearly explain MP detention procedures or the role of MI personnel within a detention setting.

GUANTANAMO

The first detainees arrived at Guantanamo in January 2002. The SOUTHCOM Commander established two joint task forces at Guantanamo to execute the detention operations (JTF-160) and the interrogation operations (JTF-170). In August of that year, based on difficulties with the command relationships, the two JTFs were organized into a single command designated as Joint Task Force Guantanamo. This reorganization was conceived to enhance unity of command and direct all activities in support of interrogation and detention operations.

INDEPENDENT PANEL TO REVIEW DoD DETENTION OPERATIONS

On November 4, 2002, MG Miller was appointed Commander of Joint Task Force Guantanamo. As the joint commander, he called upon the MP and MI soldiers to work together cooperatively. Military police were to collect passive intelligence on detainees. They became key players, serving as the eyes and ears of the cellblocks for military intelligence personnel. This collaboration helped set conditions for successful interrogation by providing the interrogator more information about the detainee—his mood, his communications with other detainees, his receptivity to particular incentives, etc. Under the single command, the relationship between MPs and MIs became an effective operating model.

AFGHANISTAN

The MP and MI commands at the Bagram Detention Facility maintained separate chains of command and remained focused on their independent missions. The Combined Joint Task Force-76 Provost Marshal was responsible for detainee operations. He designated a principal assistant to run the Bagram facility. In parallel fashion, the CJTF-76 Intelligence Officer was responsible for MI operations in the facility, working through an Officer-in-Charge to oversee interrogation operations. The two deputies worked together to coordinate execution of their respective missions. A dedicated judge advocate was assigned full time to the facility, while the CJTF-76 Inspector General provided independent oversight. Based on information from the Naval Inspector General investigation, this arrangement in Afghanistan worked reasonably well.

ABU GHRAIB, IRAQ

The Central Confinement Facility is located near the population center of Baghdad. Abu Ghraib was selected by Ambassador Bremer who envisioned it as a temporary facility to be used for criminal detainees until the new Iraqi government could be

established and an Iraqi prison established at another site. Following operations during the summer of 2003, Abu Ghraib also was designated by CJTF-7 as the detention center for security detainees. It was selected because it was difficult to transport prisoners, due to improvised explosives devices (IEDs) and other insurgent tactics, to the more remote and secure Camp Bucca, some 150 miles away.

Request for Assistance

Commander CJTF-7 recognized serious deficiencies at the prison and requested assistance. In response to this request, MG Miller and a team from Guantanamo were sent to Iraq to provide advice on facilities and operations specific to screening, interrogations, HUMINT collection and interagency integration in the short- and long- term. The team arrived in Baghdad on August 31, 2003. MG Miller brought a number of recommendations derived from his experience at Guantanamo to include his model for MP and MI personnel to work together. These collaborative procedures had worked well at Guantanamo, in part because of the high ratio of approximately one-to-one of military police to mostly compliant detainees. However, the guard-to-detainee ratio at Abu Ghraib was approximately 1 to 75, and the Military Intelligence and the Military Police had separate chains of command.

MG Ryder, the Army Provost Marshal, also made an assistance visit in mid-October 2003. He conducted a review of detainee operations in Iraq. He found flawed operating procedures, a lack of training, an inadequate prisoner classification system, understrength units and a ratio of guard to prisoners designed for "compliant" prisoners of war and not for criminals or high-risk security detainees. However, he failed to detect the warning signs of potential and actual abuse that was ongoing during his visit. The assessment team members did not identify any MP units purposely applying inappropriate confinement practices. The Ryder report continues that "Military Police, though adept at passive collection of intelligence within a facility, do not participate in

INDEPENDENT PANEL TO REVIEW DOD DETENTION OPERATIONS

Military Intelligence-supervised interrogation sessions. The 800th MP Brigade has not been asked to change its facility procedures to set the conditions for MI interviews, nor participate in those interviews.”

Prevailing Conditions

Conditions at Abu Ghraib reflected an exception to those prevailing at other theater detainee facilities. U.S. forces were operating Tiers 1A and 1B, while Tiers 2 through 7 were under the complete control of Iraqi prison guards. Iraqis who had committed crimes against other Iraqis were intended to be housed in the tiers under Iraqi control. The facility was under frequent hostile fire from mortars and rocket-propelled grenades. Detainee escape attempts were numerous and there were several riots. Both MI and MP units were seriously under-resourced and lacked unit cohesion and mid-level leadership. The reserve MP units had lost senior noncommissioned officers and other personnel through rotations back to the U.S. as well as reassignments to other missions in the theater.

When Abu Ghraib opened, the first MP unit was the 72nd MP Company, based in Henderson, Nevada. Known as “the Nevada Company,” it has been described by many involved in investigations concerning Abu Ghraib as a very strong unit that kept tight rein on operational procedures at the facility. This company called into question the interrogation practices of the MI brigade regarding nakedness of detainees. The 72nd MP Company voiced and then filed written objections to these practices.

The problems at Abu Ghraib intensified after October 15, 2003, when the 372nd Military Police Company took over the facility. The 372nd MP Company had been given the most sensitive mission: control of Tier 1A and Tier 1B, where civilian and military intelligence specialists held detainees identified for interrogations as well as “high-risk” detainees. An “MI hold” was anyone of intelligence interest and included foreign and

Iraqi terrorists, as well as individuals possessing information regarding foreign fighters, infiltration methods, or pending attacks on Coalition forces. The “high-risk” troublemakers were held in Tier 1B. The prison cells of Tiers 1A and 1B were collectively known as “the hard site.” The 372nd soldiers were not trained for prison guard duty and were thinly stretched in dealing with the large number of detainees. With little experience to fall back on, the company commander deferred to noncommissioned officers who had civilian correctional backgrounds to work the night shift. This deference was a significant error in judgment.

Leadership Shortfalls

At the leadership level, there was friction and a lack of communication between the 800th MP Brigade and the 205th MI Brigade through the summer and fall of 2003. There was no clear delineation of responsibility between commands and little coordination at the command level. Both the Director of the Joint Interrogation and Debriefing Center (JIDC) and the Commander of the 320th MP Battalion were weak and ineffective leaders. Both failed to ensure their subordinates were properly trained and supervised. They failed to establish and enforce basic soldier standards, proficiency, and accountability. Neither was able to organize tasks to accomplish their missions in an appropriate manner. By not communicating standards, policies, and plans to soldiers, these leaders conveyed a sense of tacit approval of abusive behaviors toward prisoners. This was particularly evident with respect to prisoner-handling procedures and techniques, including unfamiliarity with the Geneva Conventions. There was a lack of discipline and standards of behavior were not established nor enforced. A lax and dysfunctional command climate took hold.

In November 2003, the 205th MI Brigade Commander was assigned as the Forward Operation Base Commander, thus receiving responsibility for Abu Ghraib. This assignment was made as a result of CJTF-7 Commander’s concern over force protection at the prison. The Fay investigation found this did not change the relationship of MP and

INDEPENDENT PANEL TO REVIEW DOD DETENTION OPERATIONS

MI units in day-to-day operations at the facility, although the Commander of the 800th MP Brigade says she was denied access to areas of Abu Ghraib for which she was doctrinally responsible. Key leaders did not seem to recognize or appreciate psychological stressors associated with the detention mission. MG Taguba concluded these factors included “differences in culture, soldiers’ quality of life, and the real presence of mortal danger over an extended time period. The failure of commanders to recognize these pressures contributed to the pervasive atmosphere existing at Abu Ghraib Detention Facility.”

Military Working Dogs at Abu Ghraib

The Military Police directives give guidance for the use of military working dogs. They are used to provide an effective psychological and physical deterrent in the detention facility, offering an alternative to using firearms. Dogs are also used for perimeter security, inspections and patrols. MG Miller had recommended dogs as beneficial for detainee custody and control during his visit in August/September 2003. However, he never recommended, nor were dogs used for interrogations at Guantanamo. The working dog teams were requested by the Commander 205th MI Brigade who never understood the intent as described by MG Miller. It is likely the confusion about using dogs partially stems from the initial request for dog teams by military intelligence and not military police.

The working dogs arrived at Abu Ghraib in mid-November 2003. The two Army teams were assigned primarily to security of the compound while the three Navy teams worked inside at the entry control point. The senior Army and Navy dog handlers indicated they had not previously worked in a prison environment and received only a one-day training session on scout and search for escaped Enemy Prisoners of War. The Navy handler stated that upon arrival at Abu Ghraib he had not received an orientation on what was expected from his canine unit nor what was authorized or not authorized. He further

stated he had never received instruction on the use of force in the compound, but he acknowledged he knew a dog could not be used on a detainee if the detainee posed no threat.

Guidance provided by the CJTF-7 directive of September 14, 2003 allowed working dogs to be used as an interrogation technique with the CJTF-7 Commander's approval. This authorization was updated by the October 12, 2003 memorandum, which allowed the presence of dogs during interrogation as long as they were muzzled and under control of the handler at all times but still required approval. The Taguba and Jones/Fay investigations identified a number of abuses related to using muzzled and unmuzzled dogs during interrogations. They also identified some abuses involving dog-use unrelated to interrogations, apparently for the sadistic pleasure of the MPs involved in these incidents.

MP/MI Relationship

It is clear, with these serious shortfalls and lack of supervision, the model MG Miller presented for the effective working relationship between MI and MP was neither understood nor could it have been successfully implemented. Based on the Taguba and Jones/Fay investigations, "setting favorable conditions" had some basis in fact at Abu Ghraib, but it was also used as an excuse for abusive behavior toward detainees.

The events that took place at Abu Ghraib are an aberration when compared to the situations at other detention operations. Poor leadership and a lack of oversight set the stage for abuses to occur.

LAWS OF WAR/GENEVA CONVENTIONS

American military culture, training, and operations are steeped in a long-held commitment to the tenets of military and international law as traditionally codified by the world community. Department of Defense Directive 5100.77, DoD Law of War Program, describes the law of war as:

That part of international law that regulates the conduct of armed hostilities. It is often called the law of armed conflict. The law of war encompasses all international law for the conduct of hostilities binding on the United States or its individual citizens, including treaties and international agreements to which the United States is a party, and applicable customary international law.

The law of war includes, among other agreements, the Geneva Conventions of 1949. The Geneva Conventions set forth the rights and obligations which govern the treatment of civilians and combatants during periods of armed conflict. Specifically, Geneva Convention III addresses the treatment of prisoners of war, and Geneva Convention IV addresses the treatment of civilians.

Chairman of the Joint Chiefs of Staff Instruction 5810.01B, Implementation of the DoD Law of War Program, reiterates U.S. policy concerning the law of war: "The Armed Forces of the United States will comply with the law of war during all armed conflicts, however such conflicts are characterized...."

The United States became engaged in two distinct conflicts, Operation Enduring Freedom (OEF) in Afghanistan and Operation Iraqi Freedom (OIF) in Iraq. As a result of a Presidential determination, the Geneva Conventions did not apply to al Qaeda and Taliban combatants. Nevertheless, these traditional standards were put into effect for OIF and remain in effect at this writing. Some would argue this is a departure from the

INDEPENDENT PANEL TO REVIEW DOD DETENTION OPERATIONS

traditional view of the law of war as espoused by the ICRC and others in the international community.

Operation Enduring Freedom

On October 17, 2001, pursuant to the commencement of combat operations in OEF, the Commander, CENTCOM, issued an order instructing the Geneva Conventions were to be applied to all captured individuals in accordance with their traditional interpretation. Belligerents would be screened to determine whether or not they were entitled to prisoner of war status. If an individual was entitled to prisoner of war status, the protections of Geneva Convention III would apply. If armed forces personnel were in doubt as to a detained individual's status, Geneva Convention III rights would be accorded to the detainee until a Geneva Convention III Article 5 tribunal made a definitive status determination. If the individual was found not to be entitled to Geneva Convention III protections, he or she might be detained and processed under U.S. criminal code, a procedure consistent with Geneva Convention IV.

A policy debate concerning the application of treaties and laws to al Qaeda and Taliban detainees then began taking shape. The Department of Justice Office of Legal Counsel (OLC) provided opinions to Counsel to the President and Department of Defense General Counsel concluding the Geneva Conventions did not protect members of the al Qaeda organization, and the President could decide that Geneva Conventions did not protect Taliban militia. Counsel to the President and the Attorney General so advised the President.

On February 7, 2002 the President issued a memorandum stating, in part,

...the war against terrorism ushers in a new paradigm.... Our nation recognizes that this new paradigm – ushered in not by us, but by terrorists – requires new thinking in the law of war, but thinking that should nevertheless be consistent with the principles of Geneva.

Upon this premise, the President determined the Geneva Conventions did not apply to the U.S. conflict with al Qaeda, and that Taliban detainees did not qualify for prisoner of war status. Removed from the protections of the Geneva Conventions, al Qaeda and Taliban detainees have been classified variously as “unlawful combatants,” “enemy combatants,” and “unprivileged belligerents.”

The enemy in the Global War on Terror is one neither the United States nor the community of nations has ever before engaged on such an extensive scale. These far-reaching, well-resourced, organized, and trained terrorists are attempting to achieve their own ends. Such terrorists are not of a nation state such as those who are party to the agreements which comprise the law of war. Neither do they conform their actions to the letter or spirit of the law of war.

The Panel accepts the proposition that these terrorists are not combatants entitled to the protections of Geneva Convention III. Furthermore, the Panel accepts the conclusion the Geneva Convention IV and the provisions of domestic criminal law are not sufficiently robust and adequate to provide for the appropriate detention of captured terrorists.

The Panel notes the President qualified his determination, directing that United States policy would be “consistent with the principles of Geneva.” Among other things, the Geneva Conventions adhere to a standard calling for a delineation of rights for all persons, and humane treatment for all persons. They suggest that no person is “outlaw,” that is, outside the laws of some legal entity.

The Panel finds the details of the current policy vague and lacking. Justice Sandra Day O’Connor, writing for the majority in *Hamdi v Rumsfeld*, June 28, 2004 points out “the Government has never provided any court with the full criteria that it uses in classifying individuals as [enemy combatants].” Justice O’Connor cites several authorities to support the proposition that detention “is a clearly established principle of the law of

INDEPENDENT PANEL TO REVIEW DoD DETENTION OPERATIONS

war,” but also states there is no precept of law, domestic or international, which would permit the indefinite detention of any combatant.

As a matter of logic, there should be a category of persons who do not comply with the specified conditions and thus fall outside the category of persons entitled to EPW status. Although there is not a particular label for this category in law of war conventions, the concept of “unlawful combatant” or “unprivileged belligerent” is a part of the law of war.

Operation Iraqi Freedom

Operation Iraqi Freedom is wholly different from Operation Enduring Freedom. It is an operation that clearly falls within the boundaries of the Geneva Conventions and the traditional law of war. From the very beginning of the campaign, none of the senior leadership or command considered any possibility other than that the Geneva Conventions applied.

The message in the field, or the assumptions made in the field, at times lost sight of this underpinning. Personnel familiar with the law of war determinations for OEF in Afghanistan tended to factor those determinations into their decision-making for military actions in Iraq. Law of war policy and decisions germane to OEF migrated, often quite innocently, into decision matrices for OIF. We noted earlier the migration of interrogation techniques from Afghanistan to Iraq. Those interrogation techniques were authorized only for OEF. More important, their authorization in Afghanistan and Guantanamo was possible only because the President had determined that individuals subjected to these interrogation techniques fell outside the strict protections of the Geneva Conventions.

One of the more telling examples of this migration centers around CJTF-7’s determination that some of the detainees held in Iraq were to be categorized as unlawful

combatants. "Unlawful combatants" was a category set out in the President's February 7, 2002 memorandum. Despite lacking specific authorization to operate beyond the confines of the Geneva Conventions, CJTF-7 nonetheless determined it was within their command discretion to classify, as unlawful combatants, individuals captured during OIF. CJTF-7 concluded it had individuals in custody who met the criteria for unlawful combatants set out by the President and extended it in Iraq to those who were not protected as combatants under the Geneva Conventions, based on the OLC opinions. While CJTF-7's reasoning is understandable in respect to unlawful combatants, nonetheless, they understood there was no authorization to suspend application of the Geneva Conventions, in letter and spirit, to all military actions of Operation Iraqi Freedom. In addition, CJTF-7 had no means of discriminating detainees among the various categories of those protected under the Geneva Conventions and those unlawful combatants who were not.

**THE ROLE OF THE INTERNATIONAL
COMMITTEE OF THE RED CROSS**

Since December 2001, the International Committee of the Red Cross (ICRC) has visited U.S. detention operations in Guantanamo, Iraq, and Afghanistan numerous times. Various ICRC inspection teams have delivered working papers and reports of findings to U.S. military leaders at different levels. While the ICRC has acknowledged U.S. attempts to improve the conditions of detainees, major differences over detainee status as well as application of specific provisions of Geneva Conventions III and IV remain. If we were to follow the ICRC's interpretations, interrogation operations would not be allowed. This would deprive the U.S. of an indispensable source of intelligence in the war on terrorism.

The ICRC is an independent agency whose activities include observing and reporting on conditions in wartime detention camps and facilities. During visits, it attempts to register all prisoners, inspect facilities, and conduct private interviews with detainees to discuss any problems concerning detainee treatment or conditions; it also provides a means for detainees to contact their families. While the ICRC has no enforcing authority and its reports are supposedly confidential, any public revelation regarding standards of detainee treatment can have a substantial effect on international opinion.

The ICRC seeks to handle problems at the lowest level possible. When a team conducts an inspection, it provides a briefing, and sometimes a report, to the local commander. Discrepancies and issues are presented to the detaining authorities, and follow-up visits are made to monitor compliance with recommendations. The commander may or may not implement the recommendations based on either resource constraint or his interpretation of applicable law. These constraints can make complete implementation of ICRC recommendations either difficult or inappropriate. If recommendations are not implemented, the ICRC may address the issue with higher authorities. The ICRC does

INDEPENDENT PANEL TO REVIEW DoD DETENTION OPERATIONS

not expect to receive, nor does the DoD have a policy of providing, a written response to ICRC reports. However, DoD elements do attempt to implement as many of the recommendations as practicable, given security and resource constraints.

One important difference in approach between the U.S. and the ICRC is the interpretation of the legal status of terrorists. According to a Panel interview with CJTF-7 legal counsel, the ICRC sent a report to the State Department and the Coalition Provisional Authority in February 2003 citing lack of compliance with Protocol 1. But the U.S. has specifically rejected Protocol 1 stating that certain elements in the protocol, that provide legal protection for terrorists, make it plainly unacceptable. Still the U.S. has worked to preserve the positive elements of Protocol 1. In 1985, the Secretary of Defense noted that "certain provisions of Protocol 1 reflect customary international law, and others appear to be positive new developments. We therefore intend to work with our allies and others to develop a common understanding or declaration of principles incorporating these positive aspects, with the intention they shall, in time, win recognition as customary international law." In 1986 the ICRC acknowledged that it and the U.S. government had "agreed to disagree" on the applicability of Protocol 1. Nevertheless, the ICRC continues to presume the United States should adhere to this standard under the guise of customary international law.

This would grant legal protections to terrorists equivalent to the protections accorded to prisoners of war as required by the Geneva Conventions of 1949 despite the fact terrorists do not wear uniforms and are otherwise indistinguishable from noncombatants. To do so would undermine the prohibition on terrorists blending in with the civilian population, a situation which makes it impossible to attack terrorists without placing noncombatants at risk. For this and other reasons, the U.S. has specifically rejected this additional protocol.

The ICRC also considers the U.S. policy of categorizing some detainees as "unlawful combatants" to be a violation of their interpretation of international humanitarian law. It contends that Geneva Conventions III and IV, which the U.S. has ratified, allow for only

two categories of detainees: (1) civilian detainees who must be charged with a crime and tried and (2) enemy combatants who must be released at the cessation of hostilities. In the ICRC's view, the category of "unlawful combatant" deprives the detainees of certain human rights. It argues that lack of information regarding the reasons for detention and the conditions for release are major sources of stress for detainees.

However, the 1949 Geneva Conventions specify conditions to qualify for protected status. By logic, then, if detainees do not meet the specific requirements of privileged status, there clearly must be a category for those lacking in such privileges. The ICRC does not acknowledge such a category of "unprivileged belligerents," and argues that it is not consistent with its interpretation of the Geneva Conventions.

Regarding the application of current international humanitarian law, including Geneva Conventions III and IV, the ICRC has three concerns: (1) gaining access to and ascertaining the status of all detainees in U.S. custody; (2) its belief that linking detention with interrogations should not be allowed which follows from its refusal to recognize the category of unprivileged combatants and (3) they also worry about losing their effectiveness.

Although the ICRC found U.S. forces generally cooperative, it has cited occasions when the forces did not grant adequate access to detainees, both in Iraq and Afghanistan. Of particular concern to the ICRC, however, has been the existence of "ghost detainees," detainees who were kept from ICRC inspectors. While the Panel has not been able to ascertain the number of ghost detainees in the overall detainee population, several investigations cite their existence. Both the Taguba and Jones/Fay reports cite instances of ghost detainees at Abu Ghraib. Secretary Rumsfeld publicly declared he directed one detainee be held secretly at the request of the Director of Central Intelligence.

On balance, the Panel concludes there is value in the relationship the Department of Defense historically has had with the ICRC. The ICRC should serve as an early warning

INDEPENDENT PANEL TO REVIEW DOD DETENTION OPERATIONS

indicator of possible abuse. Commanders should be alert to ICRC observations in their reports and take corrective actions as appropriate. The Panel also believes the ICRC, no less than the Defense Department, needs to adapt itself to the new realities of conflict, which are far different from the Western European environment from which the ICRC's interpretation of Geneva Conventions was drawn. The Department of Defense has established an office of detainee affairs and should continue to reshape its operational relationship with the ICRC.

RECOMMENDATIONS

Department of Defense reform efforts are underway and the Panel commends these efforts. The Office of the Secretary of Defense, the Joint Chiefs of Staff and the Military Services are conducting comprehensive reviews on how military operations have changed since the end of the Cold War. The military services now recognize the problems and are studying how to adjust force compositions, training, doctrine and responsibilities for active/reserve/guard and contractor mixes to ensure we are better prepared to succeed in the war on terrorism.

The Panel reviewed various inspections, investigations and assessments that produced over 300 recommendations for corrective actions to address the problems identified with DoD detention operations. For the most part the Panel endorses their recommendations. In some areas the recommendations do not go far enough and we augment them. We provide additional recommendations to address relevant areas not covered by previous analyses.

The Independent Panel provides the following additional recommendations:

1. The United States should further define its policy, applicable to both the Department of Defense and other government agencies, on the categorization and status of all detainees as it applies to various operations and theaters. It should define their status and treatment in a way consistent with U.S. jurisprudence and military doctrine and with U.S. interpretation of the Geneva Conventions. We recommend that additional operational, support and staff judge advocate personnel be assigned to appropriate commands for the purpose of expediting the detainee release review process.
2. The Department of Defense needs to address and develop joint doctrine to define the appropriate collaboration between military intelligence and military police in a detention facility. The meaning of guidance, such as MPs "setting the conditions" for

INDEPENDENT PANEL TO REVIEW DOD DETENTION OPERATIONS

interrogation, needs to be defined with precision. MG Taguba argued that all detainee operations be consolidated under the responsibility of a single commander reporting directly to Commander CJTF-7. This change has now been accomplished and seems to be working effectively. Other than lack of leadership, training deficiencies in both MP and MI units have been cited most often as the needed measures to prevent detainee abuse. We support the recommendations on training articulated by the reports published by the various other reviews.

3. The nation needs more specialists for detention/interrogation operations, including linguists, interrogators, human intelligence, counter-intelligence, corrections police and behavioral scientists. Accompanying professional development and career field management systems must be put in place concurrently. The Panel agrees that some use of contractors in detention operations must continue into the foreseeable future. This is especially the case with the need for qualified interpreters and interrogators and will require rigorous oversight.

4. Joint Forces Command should chair a Joint Service Integrated Process Team to develop a new Operational Concept for Detention Operations in the new era of warfare, covering the Global War on Terror. The team should place special and early emphasis on detention operations during Counter-Insurgency campaigns and Stability Operations in which familiar concepts of front and rear areas may not apply. Attention should also be given to preparing for conditions in which normal law enforcement has broken down in an occupied or failed state. The Panel recommends that the idea of a deployable detention facility should be studied and implemented as appropriate.

5. Clearly, force structure in both MP and MI is inadequate to support the armed forces in this new form of warfare. Every investigation we reviewed refers to force structure deficiencies in some measure. There should be an active and reserve component mix of units for both military intelligence and military police. Other forces besides the Army are also in need of force structure improvements. Those forces have not been addressed

adequately in the reports reviewed by the Panel, and we recommend that the Secretaries of the Navy and Air Force undertake force structure reviews of their own to improve the performance of their Services in detention operations.

6. Well-documented policy and procedures on approved interrogation techniques are imperative to counteract the current chilling effect the reaction to the abuses have had on the collection of valuable intelligence through interrogations. Given the critical role of intelligence in the Global War on Terror, the aggressiveness of interrogation techniques employed must be measured against the value of intelligence sought, to include its importance, urgency and relevance. A policy for interrogation operations should be promulgated early on and acceptable interrogation techniques for each operation must be clearly understood by all interrogation personnel.

7. All personnel who may be engaged in detention operations, from point of capture to final disposition, should participate in a professional ethics program that would equip them with a sharp moral compass for guidance in situations often riven with conflicting moral obligations. The development of such a values-oriented ethics program should be the responsibility of the individual services with assistance provided by the Joint Chiefs of Staff.

8. Clearer guidelines for the interaction of CIA with the Department of Defense in detention and interrogation operations must be defined.

9. The United States needs to redefine its approach to customary and treaty international humanitarian law, which must be adapted to the realities of the nature of conflict in the 21st Century. In doing so, the United States should emphasize the standard of reciprocity, in spite of the low probability that such will be extended to United States Forces by some adversaries, and the preservation of United States societal values and international image that flows from an adherence to recognized humanitarian standards.

INDEPENDENT PANEL TO REVIEW DOD DETENTION OPERATIONS

10. The Department of Defense should continue to foster its operational relationship with the International Committee of the Red Cross. The Panel believes the International Committee of the Red Cross, no less than the Defense Department, needs to adapt itself to the new realities of conflict which are far different from the Western European environment from which the ICRC's interpretation of Geneva Conventions was drawn.

11. The assignment of a focal point within the office of the Under Secretary for Policy would be a useful organizational step. The new focal point for Detainee Affairs should be charged with all aspects of detention policy and also be responsible for oversight of DoD relations with the International Committee of the Red Cross.

12. The Secretary of Defense should ensure the effective functioning of rapid reporting channels for communicating bad news to senior Department of Defense leadership without prejudice to any criminal or disciplinary actions already underway. The Panel recommends consideration of a joint adaptation of procedures such as the Air Force special notification process.

13. The Panel notes that the Fay investigation cited some medical personnel for failure to report detainee abuse. As noted in that investigation, training should include the obligation to report any detainee abuse. The Panel also notes that the Army IG found significant shortfalls in training and force structure for field sanitation, preventive medicine and medical treatment requirements for detainees. As the DoD improves detention operations force structure and training, it should pay attention to the need for medical personnel to screen and monitor the health of detention personnel and detainees.

14. The integration of the recommendations in this report and all the other efforts underway on detention operations will require further study. Analysis of the dynamics of program and resource implications, with a view to assessing the trade-offs and opportunity costs involved, must be addressed.

Appendices

GLOSSARY

Army Regulation 15-6	AR 15-6	Army regulation which specifies procedures for command investigations. The common name for both formal and informal command investigations.
Active Component	AC	Active military component of the Army, Navy, Air Force or Marines.
Abuse Cases		An incident or allegation of abuse, including, but not limited to death, assault, sexual assault, and theft, that triggers a CID investigation, which may involve multiple individuals.
Behavioral Science Coordination Team	BSCT	Team comprised of medical and other specialized personnel that provides support to special operations forces.
Civilian Internees	CI	Designation of civilians encountered and detained in the theater of war.
Criminal Investigation Command	CID	Investigative agency of the U. S. Army responsible for conducting criminal investigations to which the Army is or may be a party.
Collection Points	CP	Forward locations where prisoners are collected, processed and prepared for movement to the detention center.
Coalition Provisional Authority	CPA	Interim government of Iraq, in place from May 2003 through June 2004.
Convention Against Torture and Other Cruel Inhumane or Degrading Treatment		An international treaty brought into force in 1987 which seeks to define torture and other cruel, inhuman or degrading treatment or punishment and provides a mechanism for punishing those who would inflict such treatment on others.
Enemy Prisoner of War	EPW	International Committee of the Red Cross term for prisoners of war; this status bestows certain rights to the individual in the Geneva Conventions.
Force Design Update	FDU	The Army process to review and restructure forces.

GLOSSARY

Fragmentary Order	FRAGO	An abbreviated form of an operation order (verbal, written or digital) usually issued on a day-to-day basis that eliminates the need for restarting information contained in a basic operation order.
Army Field Manual 34-52 "Intelligence Interrogation"	FM 34-52	Current manual for operations and training in interrogation techniques. The edition dated 1987 was updated in 1992.
Geneva Conventions	GC	The international treaties brought into force in August 1949. These conventions extend protections to, among others, prisoners of war and civilians in time of war.
Global War on Terror	GWOT	Worldwide operation to eradicate individuals and groups that participate in and sponsor terrorism.
Internment/Resettlement	I/R	Internment/resettlement mission assigned to specific US Army Military Police units who are responsible for the detention of Enemy Prisoners of War during armed conflict.
International Committee of the Red Cross	ICRC	Nongovernmental organization that seeks to help victims of war and internal violence.
In Lieu Of	ILO	When used in reference to manning, indicates that forces were used in a manner other than originally specified.
Initial Point of Capture	IPOC	Location where an enemy prisoner or internee is captured.
Iraq Survey Group	ISG	Organization located in Iraq with the mission to find weapons of mass destruction.
Joint Manning Document	JMD	Master document covering personnel requirements for the joint theater.
Navy Criminal Investigative Service	NCIS	Investigative service for the US Navy and Marine Corps.

GLOSSARY

National Detainee Reporting Center	NDRC	Agency charged with accounting for and reporting all EPW, retained personnel, civilian internees and other detainees during armed conflict.
Operation Enduring Freedom	OEF	Military operation in Afghanistan
Other Government Agencies	OGA	Refers to non-Department of Defense agencies operating in theaters of war.
Operation Iraqi Freedom	OIF	Military operation in Iraq.
Office of Legal Counsel	OLC	Refers to the Department of Justice Office of Legal Counsel.
Operation Noble Eagle	ONE	Operation to activate and deploy forces for homeland defense and civil support in response to the attacks of September 11, 2001.
Operation Victory Bounty	OVB	CJTF-7 operation to sweep Baghdad area for remaining elements of the Saddam Fedayeen in 2003.
Operational Control	OPCON	Command authority over all aspects of military operations.
Republican Guard	RG	Elite Iraqi military forces under the regime of Saddam Hussein.
Reserve Component	RC	Army, Navy, Air Force and Marine Reserves and Army and Air National Guard
Request for Forces	RFF	Commanders request for additional forces to support the mission.
Standing Operating Procedure	SOP	A set of instructions covering those features of operations which lend themselves to a definite or standardized procedures without loss of effectiveness. The procedure is applicable unless ordered otherwise.
Tactical Control	TACON	Command authority to control and task forces for maneuvers within an area of operations.

GLOSSARY

Tactical Human Intelligence Team	THT	Forward deployed intelligence element providing human intelligence support to maneuver units.
Time Phased Force Deployment List	TPFDL	Identifies the units needed to support an operational plan and specifies their order and method of deployment.
Army Regulation 15-6	AR 15-6	Army regulation which specifies procedures for command investigations. The common name for both formal and informal command investigations.
Active Component	AC	Active military component of the Army, Navy, Air Force or Marines.
Abuse Cases		An incident or allegation of abuse, including, but not limited to death, assault, sexual assault, and theft, that triggers a CID investigation, which may involve multiple individuals.
Behavioral Science Coordination Team	BSCT	Team comprised of medical and other specialized personnel that provides support to special operations forces.
Civilian Internees	CI	Designation of civilians encountered and detained in the theater of war.
Criminal Investigation Command	CID	Investigative agency of the U. S. Army responsible for conducting criminal investigations to which the Army is or may be a party.
Collection Points	CP	Forward locations where prisoners are collected, processed and prepared for movement to the detention center.
Coalition Provisional Authority	CPA	Interim government of Iraq, in place from May 2003 through June 2004.
Convention Against Torture and Other Cruel Inhumane or Degrading Treatment		An international treaty brought into force in 1987 which seeks to define torture and other cruel, inhuman or degrading treatment or punishment and provides a mechanism for punishing those who would inflict such treatment on others.

GLOSSARY

Enemy Prisoner of War	EPW	International Committee of the Red Cross term for prisoners of war; this status bestows certain rights to the individual in the Geneva Conventions.
Force Design Update	FDU	The Army process to review and restructure forces.
Fragmentary Order	FRAGO	An abbreviated form of an operation order (verbal, written ordigital) usually issued on a day-to-day basis that eliminates the need for restarting information contained in a basic operation order.
Army Field Manual 34-52 "Intelligence Interrogation"	FM 34-52	Current manual for operations and training in interrogation techniques. The edition dated 1987 was updated in 1992.
Geneva Conventions	GC	The international treaties brought into force in August 1949. These conventions extend protections to, among others, prisoners of war and civilians in time of war.
Global War on Terror	GWOT	Worldwide operation to eradicate individuals and groups that participate in and sponsor terrorism.
Internment/Resettlement	I/R	Internment/resettlement mission assigned to specific US Army Military Police units who are responsible for the detention of Enemy Prisoners of War during armed conflict.
International Committee of the Red Cross	ICRC	Nongovernmental organization that seeks to help victims of war and internal violence.
In Lieu Of	ILO	When used in reference to manning, indicates that forces were used in a manner other than originally specified.
Initial Point of Capture	IPOC	Location where an enemy prisoner or internee is captured.
Iraq Survey Group	ISG	Organization located in Iraq with the mission to find weapons of mass destruction.
Joint Manning Document	JMD	Master document covering personnel requirements for the joint theater.

GLOSSARY

Navy Criminal Investigative Service	NCIS	Investigative service for the US Navy and Marine Corps.
National Detainee Reporting Center	NDRC	Agency charged with accounting for and reporting all EPW, retained personnel, civilian internees and other detainees during armed conflict.
Operation Enduring Freedom	OEF	Military operation in Afghanistan
Other Government Agencies	OGA	Refers to non-Department of Defense agencies operating in theaters of war.
Operation Iraqi Freedom	OIF	Military operation in Iraq.
Office of Legal Counsel	OLC	Refers to the Department of Justice Office of Legal Counsel.
Operation Noble Eagle	ONE	Operation to activate and deploy forces for homeland defense and civil support in response to the attacks of September 11, 2001.
Operation Victory Bounty	OVB	CJTF-7 operation to sweep Baghdad area for remaining elements of the Saddam Fedayeen in 2003.
Operational Control	OPCON	Command authority over all aspects of military operations.
Republican Guard	RG	Elite Iraqi military forces under the regime of Saddam Hussein.
Reserve Component	RC	Army, Navy, Air Force and Marine Reserves and Army and Air National Guard
Request for Forces	RFF	Commanders request for additional forces to support the mission.
Standing Operating Procedure	SOP	A set of instructions covering those features of operations which lend themselves to a definite or standardized procedures without loss of effectiveness. The procedure is applicable unless ordered otherwise.
Tactical Control	TACON	Command authority to control and task forces for maneuvers within an area of operations.

GLOSSARY

**Tactical Human
Intelligence Team**

THI Forward deployed intelligence element providing human intelligence support to maneuver units.

**Time Phased Force
Deployment List**

TPFDL Identifies the units needed to support an operational plan and specifies their order and method of deployment.

GLOSSARY

			Commander
Guantanamo			
United States Southern Command	USSOUTHCOM	One of nine Unified Combatant Commands with operational control of U.S. military forces. Area of responsibility includes Guantanamo Bay, Cuba.	GEN James Hill
Joint Task Force 160	JTF-160	Initially responsible for detention operations at Guantanamo, merged in JTF-G 11/4/02.	
Joint Task Force 170	JTF-170	Initially responsible for interrogation operations at Guantanamo, merged in JTF-G 11/4/02.	
Joint Task Force Guantanamo	JTF-G	Joint task force for all operations at Guantanamo, formed 11/4/02.	
Afghanistan			
United States Central Command	USCENTCOM	One of nine Unified Commands with operational control of U.S. military forces. Area of responsibility includes Afghanistan and Iraq.	GEN John Abizaid
Coalition Forces Land Component Command	CFLCC	Senior headquarters element for multinational land forces in both Iraq and Afghanistan.	LTG David McKiernan
Combined Joint Task Force 180	CJTF-180	Forward deployed headquarters for Afghanistan.	
Iraq			
United States Central Command	USCENTCOM	One of nine Unified Commands with operational control of U.S. military forces. Area of responsibility includes Afghanistan and Iraq.	GEN John Abizaid
Coalition Forces Land Component Command	CFLCC	Senior headquarters element for multinational land forces in both Iraq and Afghanistan.	LTG David McKiernan
Combined Joint Task Force 7	CJTF-7	Forward deployed headquarters for Operation Iraqi Freedom. Replaced in May 04 by Multi National Force - Iraq and Multi National Corps - Iraq	LTG Ricardo Sanchez
Combined Joint Task Force 7 Intelligence Staff	CJTF-7 C2	Intelligence staff support to CJTF-7	MG Barbara Fast
800th Military Police Brigade	800th MP BDE	U.S. Army Reserve Military Police Brigade, responsible for all internment facilities in Iraq, and assistance to CPA Minister of Justice.	BG Janis Karpinski
Joint Interrogation and Detention Center	JDIC	Element of CJTF-7 for interrogation mission at Abu Ghuraib.	LTC Steven Jordan

GLOSSARY

320th Military Police Battalion	320th MP BN	Element of 800th Bde; assigned to Abu Ghuraib.	LTC Jerry Philabaum
372nd Military Police Company	372nd MP CO	Element of 320th Bn; assigned to Abu Ghuraib in October 2003.	CPT Donald Reese
72nd Military Police Company	72nd MP CO	Nevada National Guard MP Company, assigned to Abu Ghuraib prior to 372nd MP Co.	
205th Military Intelligence Brigade	205th MI BDE	Military Intelligence Brigade responsible for multiple Army intelligence missions throughout Iraq.	COL Thomas Pappas
519th Military Intelligence Battalion	519th MI BN	Tactical exploitation element of 525 MI Bde; Company A was located at Abu Ghuraib.	MAJ Michnewicz
Other			
United States Army Forces Command	FORSCOM	U.S. Army major command responsible for training, readiness and deployment.	



SECRETARY OF DEFENSE
1000 DEFENSE PENTAGON
WASHINGTON, DC 20301-1000

MAY 12 2004

MEMORANDUM FOR THE HONORABLE JAMES R. SCHLESINGER,
CHAIRMAN
THE HONORABLE HAROLD BROWN
THE HONORABLE TILLIE K. FOWLER
GENERAL CHARLES A. HORNER, USAF (RET.)

SUBJECT: Independent Panel to Review DoD Detention Operations

Various organizations of the Department of Defense have investigated, or will investigate, various aspects of allegations of abuse at DoD Detention Facilities and other matters related to detention operations. Thus far these inquiries include the following:

- Criminal investigations into individual allegations
- Army Provost Marshal General assessment of detention and corrections operations in Iraq
- Joint Task Force Guantanamo assistance visit to Iraq to assess intelligence operations
- Administrative Investigation under AR 15-6 regarding Abu Ghraib operations
- Army Inspector General assessment of doctrine and training for detention operations
- Commander, Joint Task Force-7 review of activities of military intelligence personnel at Abu Ghraib
- Army Reserve Command Inspector General assessment of training of Reserve units regarding military intelligence and military police
- Naval Inspector General review of detention procedures at Guantanamo Bay, Cuba, and the Naval Consolidated Brig, Charleston, South Carolina

I have been or will be briefed on the results of these inquiries and the corrective actions taken by responsible officials within the Department.

It would be helpful to me to have your independent, professional advice on the issues that you consider most pertinent related to the various allegations, based on your review of completed and pending investigative reports and other materials and information. I am especially interested in your views on the cause of the problems and what should be done to fix them. Issues such as force structure, training of regular and reserve personnel, use of contractors, organization, detention policy and procedures, interrogation policy and procedures, the relationship between detention and interrogation, compliance with the Geneva Conventions, relationship with the International Committee



OSD 06804-04

cc B

of the Red Cross, command relationships, and operational practices may be contributing factors you might wish to review. Issues of personal accountability will be resolved through established military justice and administrative procedures, although any information you may develop will be welcome.

I would like your independent advice orally and in writing, preferably within 45 days after you begin your review. DoD personnel will collect information for your review and assist you as you deem appropriate. You are to have access to all relevant DoD investigations and other DoD information unless prohibited by law. Reviewing all written materials relevant to these issues may be sufficient to allow you to provide your advice. Should you believe it necessary to travel or conduct interviews, the Director of Administration and Management will make appropriate arrangements.

I intend to provide your report to the Committees on Armed Services, the Secretaries of the Military Departments, the Chairman of the Joint Chiefs of Staff, the Commanders of the Combatant Commands, the Directors of the Defense Agencies, and others as appropriate. If your report contains classified information, please also provide an unclassified version suitable for public release.

By copy of this memorandum, I request the Director of Administration and Management to secure the necessary technical, administrative and legal support for your review from the Department of Defense Components. I appoint you as full-time employees of this Department without pay under 10 U.S.C. §1583. I request all Department of Defense personnel to cooperate fully with your review and to make available all relevant documents and information at your request.



cc: SECRETARIES OF THE MILITARY DEPARTMENTS
CHAIRMAN OF THE JOINT CHIEFS OF STAFF
UNDER SECRETARIES OF DEFENSE
DIRECTOR, DEFENSE RESEARCH AND ENGINEERING
ASSISTANT SECRETARIES OF DEFENSE
GENERAL COUNSEL OF THE DEPARTMENT OF DEFENSE
INSPECTOR GENERAL OF THE DEPARTMENT OF DEFENSE
DIRECTOR, OPERATIONAL TEST AND EVALUATION
ASSISTANTS TO THE SECRETARY OF DEFENSE

DIRECTOR, ADMINISTRATION AND MANAGEMENT
DIRECTOR, FORCE TRANSFORMATION
DIRECTOR, NET ASSESSMENT
DIRECTOR, PROGRAM ANALYSIS AND EVALUATION
DIRECTORS OF THE DEFENSE AGENCIES
DIRECTORS OF THE DOD FIELD ACTIVITIES

THE WHITE HOUSE
WASHINGTON

February 7, 2002

MEMORANDUM FOR THE VICE PRESIDENT
THE SECRETARY OF STATE
THE SECRETARY OF DEFENSE
THE ATTORNEY GENERAL
CHIEF OF STAFF TO THE PRESIDENT
DIRECTOR OF CENTRAL INTELLIGENCE
ASSISTANT TO THE PRESIDENT FOR NATIONAL
SECURITY AFFAIRS
CHAIRMAN OF THE JOINT CHIEFS OF STAFF

SUBJECT: Humane Treatment of al Qaeda and Taliban Detainees

1. Our recent extensive discussions regarding the status of al Qaeda and Taliban detainees confirm that the application of the Geneva Convention Relative to the Treatment of Prisoners of War of August 12, 1949 (Geneva) to the conflict with al Qaeda and the Taliban involves complex legal questions. By its terms, Geneva applies to conflicts involving "High Contracting Parties," which can only be states. Moreover, it assumes the existence of "regular" armed forces fighting on behalf of states. However, the war against terrorism ushers in a new paradigm, one in which groups with broad, international reach commit horrific acts against innocent civilians, sometimes with the direct support of states. Our Nation recognizes that this new paradigm -- ushered in not by us, but by terrorists -- requires new thinking in the law of war, but thinking that should nevertheless be consistent with the principles of Geneva.
2. Pursuant to my authority as Commander in Chief and Chief Executive of the United States; and relying on the opinion of the Department of Justice dated January 22, 2002, and on the legal opinion rendered by the Attorney General in his letter of February 1, 2002, I hereby determine as follows:
 - a. I accept the legal conclusion of the Department of Justice and determine that none of the provisions of Geneva apply to our conflict with al Qaeda in Afghanistan or elsewhere throughout the world because, among other reasons, al Qaeda is not a High Contracting Party to Geneva.
 - b. I accept the legal conclusion of the Attorney General and the Department of Justice that I have the authority under the Constitution to suspend Geneva as between the United States and Afghanistan, but I decline to

[REDACTED]

exercise that authority at this time. Accordingly, I determine that the provisions of Geneva will apply to our present conflict with the Taliban. I reserve the right to exercise this authority in this or future conflicts.

- c. I also accept the legal conclusion of the Department of Justice and determine that common Article 3 of Geneva does not apply to either al Qaeda or Taliban detainees, because, among other reasons, the relevant conflicts are international in scope and common Article 3 applies only to "armed conflict not of an international character."
 - d. Based on the facts supplied by the Department of Defense and the recommendation of the Department of Justice, I determine that the Taliban detainees are unlawful combatants and, therefore, do not qualify as prisoners of war under Article 4 of Geneva. I note that, because Geneva does not apply to our conflict with al Qaeda, al Qaeda detainees also do not qualify as prisoners of war.
3. Of course, our values as a Nation, values that we share with many nations in the world, call for us to treat detainees humanely, including those who are not legally entitled to such treatment. Our Nation has been and will continue to be a strong supporter of Geneva and its principles. As a matter of policy, the United States Armed Forces shall continue to treat detainees humanely and, to the extent appropriate and consistent with military necessity, in a manner consistent with the principles of Geneva.
 4. The United States will hold states, organizations, and individuals who gain control of United States personnel responsible for treating such personnel humanely and consistent with applicable law.
 5. I hereby reaffirm the order previously issued by the Secretary of Defense to the United States Armed Forces requiring that the detainees be treated humanely and, to the extent appropriate and consistent with military necessity, in a manner consistent with the principles of Geneva.
 6. I hereby direct the Secretary of State to communicate my determinations in an appropriate manner to our allies, and other countries and international organizations cooperating in the war against terrorism of global reach.

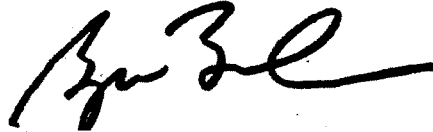

Interrogation Policies in Guantanamo, Afghanistan and Iraq

17	FM 34-52 (1992)	Jan 02 - 01 Dec 02	17	FM 34-52 (1992)	27 Oct 01 - 24 Jan 03	17	FM 34-52 (1992)	
33	Secretary of Defense Approved Tiered System	02 Dec 02 - 15 Jan 03	33	CJTF 180 Response to Director, Joint Staff	24-Jan-03	1, 3, 6	CJTF-7 Signed Policy	14-Sep-03
20	FM 34-52 (1992) with 3 Cat I Techniques	16 Jan 03 - 15 Apr 03	32	CJTF 180 Detainee SOP	27-Mar-04	1	CJTF-7 Signed Policy	12-Oct-03
24	Secretary of Defense Memo	16 Apr 03 - Present	19	CJTF-A Rev 2 Guidance	Jun-04	4	CJTF-7 Signed Policy	13-May-04

1 Some techniques specifically delineated in this memo are inherent to techniques contained in FM 34-52, e.g. Yelling as a component of Fear Up.

2 Five Approved Techniques require SOUTHCOM approval and SECDEF notification.

3 Figure includes techniques that were not in current use but requested for future use.

4 Figure includes one technique which requires CG approval.

5 Memorandum cited for Afghanistan and Iraq are classified.

6 Figure includes the 17 techniques of FM-34-52, although they are not specified in the Memo.

Evolution of Interrogation Techniques - GTMO

Interrogation Techniques	FM 34-52 (1992)		Secretary of Defense Approved Tiered System		FM 34-52 (1992) with some Cat I		Secretary of Defense Memo	
	Jan 02 - 01 Dec 02	02 Dec 02 - 15 Jan 03	16 Jan 03 - 15 Apr 03	16 Apr 03 - Present	16 Jan 03 - 15 Apr 03	16 Apr 03 - Present	16 Apr 03 - Present	16 Apr 03 - Present
Direct questioning	X	X	X	X	X	X	X	X
Incentive/removal of incentive	X	X	X	X	X	X	X	X
Emotional love	X	X	X	X	X	X	X	X
Emotional hate	X	X	X	X	X	X	X	X
Fear up harsh	X	X	X	X	X	X	X	X
Fear up mild	X	X	X	X	X	X	X	X
Reduced fear	X	X	X	X	X	X	X	X
Pride and ego up	X	X	X	X	X	X	X	X
Pride and ego down	X	X	X	X	X	X	X	X
Futility	X	X	X	X	X	X	X	X
We know all	X	X	X	X	X	X	X	X*
Establish your identity	X	X	X	X	X	X	X	X
Repetition approach	X	X	X	X	X	X	X	X
File and dossier	X	X	X	X	X	X	X	X
Mut and Jeff	X	X	X	X	X	X	X	X
Rapid Fire	X	X	X	X	X	X	X	X*
Silence	X	X	X	X	X	X	X	X
Change of Scene	X	X	X	X	X	X	X	X
Yelling	X	X	X	X	X	X	X	X
Deception	X	X	X	X	X	X	X	X
Multiple interrogators	X	X	X	X	X	X	X	X
Interrogator identity	X	X	X	X	X	X	X	X
Stress positions, like standing	X	X	X	X	X	X	X	X
False documents/reports	X	X	X	X	X	X	X	X
Isolation for up to 30 days	X	X	X	X	X	X	X	X*
Deprivation of light/auditory stimuli	X	X	X	X	X	X	X	X*
Hooding (transpiration & questioning)	X	X	X	X	X	X	X	X
20- interrogations	X	X	X	X	X	X	X	X
Removal of ALL comfort items, including religious items	X	X	X	X	X	X	X	X*
MRE-only diet	X	X	X	X	X	X	X	X*
Removal of clothing	X	X	X	X	X	X	X	X*
Forced grooming	X	X	X	X	X	X	X	X
Exploiting individual phobias e.g. dogs	X	X	X	X	X	X	X	X
Mild, non-injurious physical contact, e.g. grabbing, poking or light pushing	X	X	X	X	X	X	X	X
Environmental manipulation	X	X	X	X	X	X	X	X
Sleep adjustment	X	X	X	X	X	X	X	X
False flag	X	X	X	X	X	X	X	X

*Techniques require SOUTHCOM approval and SECDEF notification.

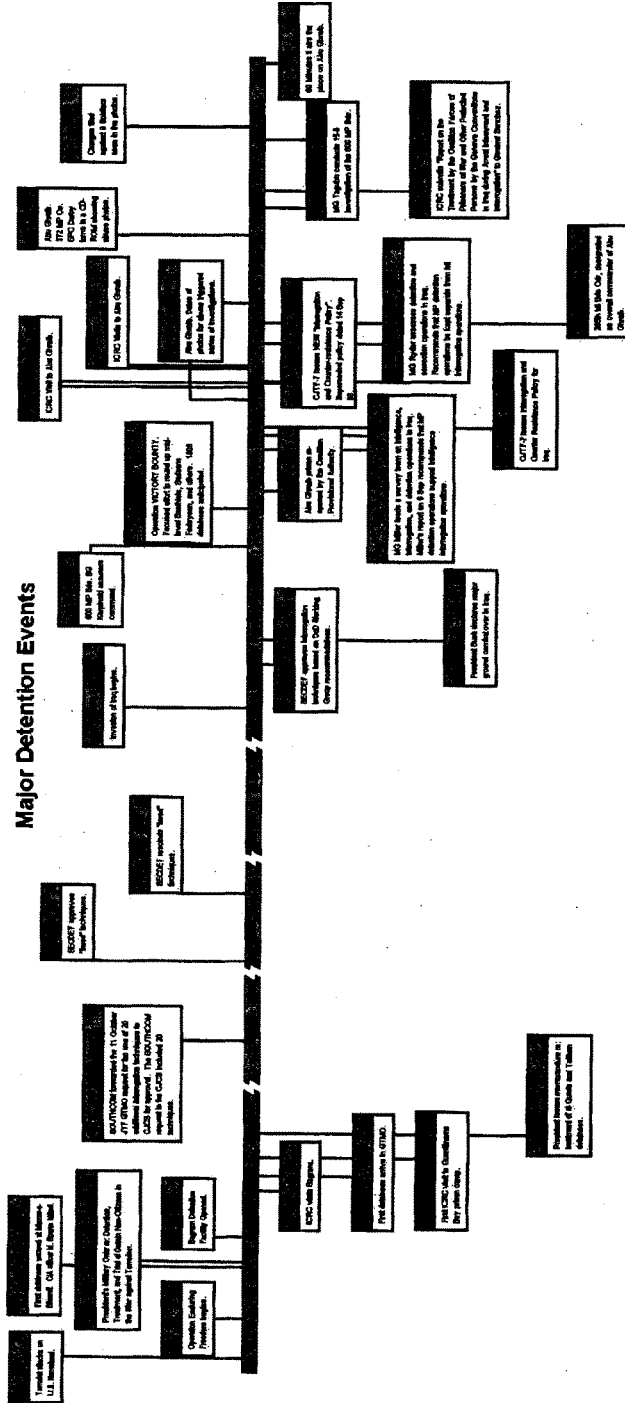

PSYCHOLOGICAL STRESSES

The potential for abusive treatment of detainees during the Global War on Terrorism was entirely predictable based on a fundamental understanding of the principle of social psychology principles coupled with an awareness of numerous known environmental risk factors. Most leaders were unacquainted with these known risk factors, and therefore failed to take steps to mitigate the likelihood that abuses of some type would occur during detainee operations. While certain conditions heightened the possibility of abusive treatment, such conditions neither excuse nor absolve the individuals who engaged in deliberate immoral or illegal behaviors.

The abuse the detainees endured at various places and times raises a number of questions about the likely psychological aspects of inflicting such abuses. Findings from the field of social psychology suggest that the conditions of war and the dynamics of detainee operations carry inherent risks for human mistreatment, and therefore must be approached with great caution and careful planning and training.

The Stanford Prison Experiment

In 1973, Haney, Banks and Zimbardo (1) published their landmark Stanford study, "Interpersonal Dynamics in a Simulated Prison." Their study provides a cautionary tale for all military detention operations. The Stanford Experiment used a set of tested, psychologically sound college students in a benign environment. In contrast, in military detention operations, soldiers work under stressful combat conditions that are far from benign.

The Stanford Prison Experiment (SPE) attempted to "create a prison-like situation" and then observe the behavior of those involved. The researchers randomly assigned 24 young men to either the "prisoner" or "guard" group. Psychological testing was used to eliminate participants with overt psychopathology, and extensive efforts were made to

INDEPENDENT PANEL TO REVIEW DoD DETENTION OPERATIONS

simulate actual prison conditions. The experiment, scheduled to last two weeks, was cancelled after only six days due to the ethical concerns raised by the behaviors of the participants. The study notes that while guards and prisoners were free to engage in any form of interpersonal interactions, the “characteristic nature of their encounters tended to be negative, hostile, affrontive and dehumanizing.”

The researchers found that both prisoners and guards exhibited “pathological reactions” during the course of the experiment. Guards fell into three categories: (1) those who were “tough but fair,” (2) those who were passive and reluctant to use coercive control and, of special interests, (3) those who “went far beyond their roles to engage in creative cruelty and harassment.” With each passing day, guards “were observed to generally escalate their harassment of the prisoners.” The researchers reported: “We witnessed a sample of normal, healthy American college students fractionate into a group of prison guards who seemed to derive pleasure from insulting, threatening, humiliating, and dehumanizing their peers.”

Because of the random assignment of subjects, the study concluded the observed behaviors were the result of situational rather than personality factors:

The negative, anti-social reactions observed were not the product of an environment created by combining a collection of deviant personalities, but rather, the result of an intrinsically pathological situation which could distort and rechannel the behaviour of essentially normal individuals. The abnormality here resided in the psychological nature of the situation and not in those who passed through it.

The authors discussed how prisoner-guard interactions shaped the evolution of power use by the guards:

The use of power was self-aggrandizing and self-perpetuating. The guard power, derived initially from an arbitrary label, was intensified whenever there was any perceived threat by the prisoners and this new level subsequently became the baseline from which further hostility and harassment would begin. The most hostile guards on each shift moved spontaneously into the leadership roles of

giving orders and deciding on punishments. They became role models whose behaviour was emulated by other members of the shift. Despite minimal contact between the three separate guard shifts and nearly 16 hours a day spent away from the prison, the absolute level of aggression as well as the more subtle and “creative” forms of aggression manifested, increased in a spiraling function. Not to be tough and arrogant was to be seen as a sign of weakness by the guards and even those “good” guards who did not get as drawn into the power syndrome as the others respected the implicit norm of never contradicting or even interfering with an action of a more hostile guard on their shift.

In an article published 25 years after the Stanford Prison Experiment, Haney and Zimbardo noted their initial study “underscored the degree to which institutional settings can develop a life of their own, independent of the wishes, intentions, and purposes of those who run them.” They highlighted the need for those outside the culture to offer external perspectives on process and procedures. (2)

Social Psychology: Causes of Aggression and Inhumane Treatment

The field of social psychology examines the nature of human interactions. Researchers in the field have long been searching to understand why humans sometimes mistreat fellow humans. The discussions below examine the factors behind human aggression and inhumane treatment, striving to impart a better understanding of why detainee abuses occur.

Human Aggression

Research has identified a number of factors that can assist in predicting human aggression. These factors include:

INDEPENDENT PANEL TO REVIEW DOD DETENTION OPERATIONS

- **Personality traits.** Certain traits among the totality of an individual's behavioral and emotional make-up predispose to be more aggressive than other individuals.
- **Beliefs.** Research reveals those who believe they can carry out aggressive acts, and that such acts will result in a desired outcome, are more likely to be aggressive than those who do not hold these beliefs.
- **Attitudes.** Those who hold more positive attitudes towards violence are more likely to commit violent acts.
- **Values.** The values individuals hold vary regarding the appropriateness of using violence to resolve interpersonal conduct.
- **Situational Factors.** Aggressive cues (the presence of weapons), provocation (threats, insults, aggressive behaviors), frustration, pain and discomfort (hot temperatures, loud noises, unpleasant odors), and incentives can all call forth aggressive behaviors.
- **Emotional factors.** Anger, fear, and emotional arousal can heighten the tendency to act out aggressively.

The personality traits, belief systems, attitudes, and values of those who perpetrated detainee abuses can only be speculated upon. However, it is reasonable to assume, in any given population, these characteristics will be distributed along a bell curve, which will predispose some more than others within a group to manifest aggressive behaviors. These existing traits can be affected by environmental conditions, which are discussed later.

Abusive Treatment

Psychologists have attempted to understand how and why individuals and groups who usually act humanely can sometimes act otherwise in certain circumstances. A number of psychological concepts explain why abusive behavior occurs. These concepts include:

INDEPENDENT PANEL TO REVIEW DoD DETENTION OPERATIONS

Deindividuation. Deindividuation is a process whereby the anonymity, suggestibility, and contagion provided in a crowd allows individuals to participate in behavior marked by the temporary suspension of customary rules and inhibitions. Individuals within a group may experience reduced self-awareness which can also result in disinhibited behavior.

Groupthink. Individuals often make very uncharacteristic decisions when part of a group. Symptoms of groupthink include: (1) Illusion of invulnerability—group members believe the group is special and morally superior; therefore its decisions are sound; (2) Illusion of unanimity in which members assume all are in concurrence, and (3) Pressure is brought to bear on those who might dissent.

Dehumanization. Dehumanization is the process whereby individuals or groups are viewed as somehow less than fully human. Existing cultural and moral standards are often not applied to those who have been dehumanized.

Enemy Image. Enemy image describes the phenomenon wherein both sides participating in a conflict tend to view themselves as good and peace-loving peoples, while the enemy is seen as evil and aggressive.

Moral Exclusion. Moral exclusion is a process whereby one group views another as fundamentally different, and therefore prevailing moral rules and practices apply to one group but not the other.

Abuse and Inhumane Treatment in War

Socialization to Evil and Doubling. Dr. Robert Jay Lifton has extensively examined the nature of inhumane treatment during war. Dr. Lifton suggested that ordinary people can experience “socialization to evil,” especially in a war environment. Such people often experience a “doubling.” They are socialized to evil in one environment and act accordingly within that environment, but they think and behave otherwise when removed from that environment. For example, doctors committed unspeakable acts while working in Auschwitz, but would go home on weekends and behave as “normal” husbands and fathers.

INDEPENDENT PANEL TO REVIEW DOD DETENTION OPERATIONS

Moral Disengagement. Moral disengagement occurs when normal self-regulatory mechanisms are altered in a way that allows for abusive treatment and similar immoral behaviors. Certain conditions, identified by Bandura and his colleagues (3), can lead to moral disengagement, such as:

- **Moral Justification.** Misconduct can be justified if it is believed to serve a social good.
- **Euphemistic Language.** Language affects attitudes and beliefs, and the use of euphemistic language such as “softening up” (and even “humane treatment”) can lead to moral disengagement.
- **Advantageous Comparison.** “Injurious conduct can be rendered benign” when compared to more violent behaviors. This factor is likely to occur during war. Essentially, abusive behaviors may appear less significant and somehow justifiable when compared to death and destruction.
- **Displacement of Responsibility.** “People view their actions as springing from the social pressures or dictates of others rather than as something for which they are socially responsible.” This is consistent with statements from those under investigation for abuses.
- **Diffusion of Responsibility.** Group decisions and behaviors can obscure responsibility: “When everyone is responsible, no one really feels responsible.”
- **Disregarding or Distorting the Consequences of Actions.** Harmful acts can be minimized or ignored when the harm is inflicted for personal gain or because of social inducements.
- **Attribution of Blame.** “Victims get blamed for bringing suffering on themselves.”

Detainee and interrogation operations consist of a special subset of human interactions, characterized by one group which has significant power and control over another group which must be managed, often against the will of its members. Without proper oversight

INDEPENDENT PANEL TO REVIEW DOD DETENTION OPERATIONS

and monitoring, such interactions carry a higher risk of moral disengagement on the part of those in power and, in turn, are likely to lead to abusive behaviors.

Environmental Factors

The risk of abusive behaviors is best understood by examining both psychological and environmental risk factors. A cursory examination of situational variables present at Abu Ghraib indicates the risk for abusive treatment was considerable. Many of the problematic conditions at Abu Ghraib are discussed elsewhere in this report, to include such factors as poor training, under nearly daily attack, insufficient staffing, inadequate oversight, confused lines of authority, evolving and unclear policy, and a generally poor quality of life. The stresses of these conditions were certainly exacerbated by delayed troop rotations and by basic issues of safety and security. Personnel needed to contend with both internal threats from volatile and potentially dangerous prisoners and external threats from frequent mortar fire and attacks on the prison facilities.

The widespread practice of stripping detainees, another environmental factor, deserves special mention. The removal of clothing interrogation technique evolved into something much broader, resulting in the practice of groups of detainees being kept naked for extended periods at Abu Ghraib. Interviews with personnel at Abu Ghraib indicated that naked detainees were a common sight within the prison, and this was understood to be a general part of interrogation operations.

While the removal of clothing may have been intended to make detainees feel more vulnerable and therefore more compliant with interrogations, this practice is likely to have had a psychological impact on guards and interrogators as well. The wearing of clothes is an inherently social practice, and therefore the stripping away of clothing may have had the unintended consequence of dehumanizing detainees in the eyes of those who interacted with them. As discussed earlier, the process of dehumanization lowers the moral and cultural barriers that usually preclude the abusive treatment of others.

INDEPENDENT PANEL TO REVIEW DOD DETENTION OPERATIONS

- (1) Haney, C., Banks, C., and Zimbardo, P., Interpersonal Dynamics in a Simulated Prison, *International Journal of Criminology and Penology*, 1973, 1, 69-97.
- (2) Haney, C. and Zimbardo, P., The Past and Future of U.S. Prison Policy, Twenty-Five Years after the Stanford Prison Experiment, *American Psychologist*, July 1998, 709-27.
- (3) Bandura, A., Barbaranelli, C., Caprara, G., and Pastorelli, C., Mechanisms of Moral Disengagement in the Exercise of Moral Agency, *Journal of Personality and Social Psychology*, Vol. 71(2), August 1996, 364-74.

ETHICAL ISSUES

Introduction

For the United States and other nations with similar value systems, detention and interrogation are themselves ethically challenging activities. Effective interrogators must deceive, seduce, incite, and coerce in ways not normally acceptable for members of the general public. As a result, the U. S. places restrictions on who may be detained and the methods interrogators may employ. Exigencies in the Global War on Terror have stressed the normal American boundaries associated with detention and interrogation. In the ensuing moral uncertainty, arguments of military necessity make the ethical foundation of our soldiers especially important.

Ethical Foundations of Detention and Interrogation

Within our values system, consent is a central moral criterion on evaluating our behavior toward others. Consent is the manifestation of the freedom and dignity of the person and, as such, plays a critical role in moral reasoning. Consent *restrains*, as well as *enables*, humans in their treatment of others. Criminals, by not respecting the rights of others, may be said to have consented – in principle – to arrest and possible imprisonment. In this construct – and due to the threat they represent – insurgents and terrorists “consent” to the possibility of being captured, detained, interrogated, or possibly killed.

Permissions and Limits on Detentions

This guideline of implied consent for the U.S. first limits who may be detained. Individuals suspected of insurgent or terrorist activity may be detained to prevent them from conducting further attacks and to gather intelligence to prevent other insurgents and terrorists from conducting attacks. This suggests two categories of persons who may be

INDEPENDENT PANEL TO REVIEW DOD DETENTION OPERATIONS

detained and interrogated: (1) persons who have engaged in or assisted those who engage in terrorist or insurgent activities; and (2) persons who have come by information regarding insurgent and terrorist activity.

By engaging in such activities, persons in the first category may be detained as criminals or enemy combatants, depending on the context. Persons in the second category may be detained and questioned for specific information, but if they do not represent a continuing threat, they may be detained only long enough to obtain the information.

Permissions and Limits on Interrogation Techniques

For the U.S., most cases for permitting harsh treatment of detainees on moral grounds begin with variants of the “ticking time bomb” scenario. The ingredients of such scenarios usually include an impending loss of life, a suspect who knows how to prevent it—and in most versions is responsible for it—and a third party who has no humane alternative to obtain the information in order to save lives. Such cases raise a perplexing moral problem: Is it permissible to employ inhumane treatment when it is believed to be the only way to prevent loss of lives? In periods of emergency, and especially in combat, there will always be a temptation to override legal and moral norms for morally good ends. Many in Operations Enduring Freedom and Iraqi Freedom were not well prepared by their experience, education, and training to resolve such ethical problems.

A morally consistent approach to the problem would be to recognize there are occasions when violating norms is understandable but not necessarily correct—that is, we can recognize that a good person might, in good faith, violate standards. In principle, someone who, facing such a dilemma, committed abuse should be required to offer his actions up for review and judgment by a competent authority. An excellent example is the case of a 4th Infantry Division battalion commander who permitted his men to beat a detainee whom he had good reason to believe had information about future attacks against his unit. When the beating failed to produce the desired results, the commander

INDEPENDENT PANEL TO REVIEW DOD DETENTION OPERATIONS

fired his weapon near the detainee's head. The technique was successful and the lives of U.S. servicemen were likely saved. However, his actions clearly violated the Geneva Conventions and he reported his actions knowing he would be prosecuted by the Army. He was punished in moderation and allowed to retire.

In such circumstances interrogators must apply a "minimum harm" rule by not inflicting more pressure than is necessary to get the desired information. Further, any treatment that causes permanent harm would not be permitted, as this surely constitutes torture. Moreover, any pain inflicted to teach a lesson or after the interrogator has determined he cannot extract information is morally wrong.

National security is an obligation of the state, and therefore the work of interrogators carries a moral justification. But the methods employed should reflect this nation's commitment to our own values. Of course the tension between military necessity and our values will remain. Because of this, military professionals must accept the reality that during crises they may find themselves in circumstances where lives will be at stake and the morally appropriate methods to preserve those lives may not be obvious. This should not preclude action, but these professionals must be prepared to accept the consequences.

Ethics Education

The instances of detainee abuse in Iraq and Afghanistan do indicate a review of military ethics education programs is needed. This is not to suggest that more adequate ethics education will necessarily prevent abuses. Major service programs such as the Army's "core values," however, fail to adequately prepare soldiers working in detention operations.

While there are numerous ethics education programs throughout the services, almost all refer to certain "core values" as their foundation. Core-values programs are grounded in

INDEPENDENT PANEL TO REVIEW DOD DETENTION OPERATIONS

organizational efficacy rather than the moral good. They do not address humane treatment of the enemy and noncombatants, leaving military leaders and educators an incomplete tool box with which to deal with "real-world" ethical problems. A professional ethics program addressing these situations would help equip them with a sharper moral compass for guidance in situations often riven with conflicting moral obligations.

Independent Panel to Review DoD Detention Operations

Deputy Executive Director
Colonel Gregory A. Schumacher, USAR

Executive Officer
LCDR Sheila Noles, USN

Executive Assistant
EI Rita Cook-Hammeling

Director of Analysis
Margaret Munson

Research Staff

Karl D. Baker
Research Assistant

William C. Barlate
Force Structure Issues

LT Col Deborah Doherty, USMC-R
Military Police Issues

Rebecca R. Donegan
Intelligence Issues

LT Col James Feyrer, USAF
Behavioral Science

Dr. Amos A. Jordan
Policy Issues

Jackie Mather
Research Assistant

Jacob Neufeld, USAF,
Historian

LT Col Perry Paloque, USAF
Law

LTC Tony Pflaff, Joint Staff
Ethics

George Wilson, USAF
Historian

Meghan Wood
Research Assistant

Support Staff

Tom Alexander
Director of Communications

LCDR Todd Bahau, USN
Deputy Executive Officer

SSGT Erik D. Battaglia, USMC
Resource Manager

Wanda Brisco
IT Support

MSG Floydell Jackson, USAF
Executive Assistant to Panelists

Thomas Johns
IT Support Supervisor

SFC Kevin Johnson, USA
Security Manager

SSGT Terence McKenna, USMC
Administrative Assistant

SSGT Andrea Powers, USMC
Administrative Assistant

Thomas Prudhomme
WHS Security Manager

Colleen Sheehan
IT Support

Debra Swedek
Editor

Cover design by Karl Baker

[Questions for the record with answers supplied follow:]

QUESTIONS SUBMITTED BY SENATOR SUSAN COLLINS

GHOST DETAINEES

1. Senator COLLINS. Dr. Schlesinger, do we know precisely how many detainees were kept off the books?

Dr. SCHLESINGER. No, our panel did not have that information. Indications were that there was a small, though significant, number. In just one case was the authorization at senior levels of the department sought.

2. Senator COLLINS. Dr. Schlesinger, what was the motivation for this? Was it due to concerns that mistreatment of these prisoners would be revealed or was it because military leadership wanted to keep the identities of these individuals secret?

Dr. SCHLESINGER. The motivation in the DOD was to accommodate the DCI, and whatever authorization he may have had from higher levels. I suspect that the purpose was to keep unknown the questioning of particular individuals—rather than that they were being “mistreated,” which in any event was certainly not authorized. As a general proposition, military leadership was uneasy about keeping identities of these individuals secret, and was, in some cases, resisted.

COOPERATION WITH CENTRAL INTELLIGENCE AGENCY AND DEPARTMENT OF DEFENSE

3. Senator COLLINS. Dr. Schlesinger, were you satisfied with the level of cooperation you received from the CIA and the DOD?

Dr. SCHLESINGER. Our panel was created by Secretary Rumsfeld for the DOD. We received total cooperation from the DOD. We are not authorized to investigate the CIA. We did receive some courtesies from the agency, but I would not characterize it as cooperation.

QUESTIONS SUBMITTED BY SENATOR EDWARD M. KENNEDY

GENEVA CONVENTIONS

4. Senator KENNEDY. Dr. Schlesinger, your report suggests you are recommending the U.S. needs to redefine its understanding of international human rights law in relation to the global war on terrorism. Do you believe that international human rights laws do not provide for terrorists or enemy combatants?

Dr. SCHLESINGER. The Geneva Conventions adopted in 1949, envisaged a continuation of wars between nation states. It did not envisage insurgencies (and was never applied by colonial powers)—or “wars of national liberation.” More importantly, it clearly does not apply to terrorism. The attempt in the 1970s to redress these omissions through Protocol I was regarded by the United States as inappropriate, if not pernicious, in treating terrorists as prisoners of war.

I believe that international law in the form of the Geneva Conventions does, indeed, provide for enemy or illegal combatants in that those entitled to protection as prisoners of war must meet specific standards. Therefore, by logic, if they do not meet those specific requirements, they are not entitled to prisoner of war status. If they are engaged in combat, therefore, they logically belong in a different category—of enemy or illegal combatant. On the other hand, it is quite clear that international law deals quite ineffectively with widespread terrorism, and should be adjusted to deal with terrorism.

5. Senator KENNEDY. Dr. Schlesinger, do you feel that international human rights law is inadequate, even though it includes basic requirements related to conditions and treatment of prisoners or internees, specifically provides for the prosecution of combatants and of “enemy combatants” alike for criminal conduct and/or war crimes carried out during a conflict?

Dr. SCHLESINGER. International law provides adequately for the prosecution of criminal conduct and/or war crimes carried out in a conflict. It does not provide adequately for criminal conduct carried on as terrorism.

6. Senator KENNEDY. Dr. Schlesinger, do you believe that the Third and Fourth Geneva Conventions allow indefinite detention without any independent legal review?

Dr. SCHLESINGER. The Geneva Conventions do not allow indefinite detention in the absence of review by a "competent tribunal." The latter should be distinguished from "independent legal review."

[Whereupon, at 5:19 p.m., the committee adjourned.]

